

ORGANIZATION NAME(S) AND ADDRESS(ES) UDSEN CORPORATION D	8. PERFORMING REPORT NUM 92056E
MONITORING AGENCY NAME(S) AND ADDRESS(ES)	10. SPONSORING AGENCY REP

S DTIC **D**
ELECTE
JUN 1, 4 1995
F

This document has been approved
for public release and sale; its
distribution is unlimited.

19950612 128

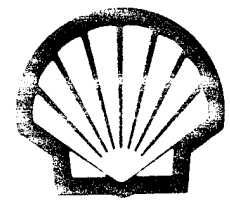

Shell Oil Company

REPORT DOCUMENTATION PAGE

Form Approved
OMB No. 0704-0188

Public reporting burden for this collection of information is estimated to average 1 hour per response, including the time for reviewing instructions, searching existing data sources, gathering and maintaining the data needed, and completing and reviewing the collection of information. Send comments regarding this burden estimate or any other aspect of this collection of information, including suggestions for reducing this burden, to Washington Headquarters Services, Directorate for Information Operations and Reports, 1215 Jefferson Davis Highway, Suite 1204, Arlington, VA 22202-4302, and to the Office of Management and Budget, Paperwork Reduction Project (0704-0188), Washington, DC 20503.

1. AGENCY USE ONLY (Leave blank)	2. REPORT DATE 01/00/92	3. REPORT TYPE AND DATES COVERED
----------------------------------	----------------------------	----------------------------------

4. TITLE AND SUBTITLE IMPLEMENTATION DOCUMENT FOR NORTHWEST BOUNDARY SYSTEM, LONG-TERM IMPROVEMENTS, INTERIM RESPONSE ACTION, FINAL	5. FUNDING NUMBERS
--	--------------------

6. AUTHOR(S)	
--------------	--

7. PERFORMING ORGANIZATION NAME(S) AND ADDRESS(ES) MORRISON KNUDSEN CORPORATION DENVER, CO	8. PERFORMING ORGANIZATION REPORT NUMBER 92056R01
--	--

9. SPONSORING / MONITORING AGENCY NAME(S) AND ADDRESS(ES) SHELL OIL COMPANY DENVER, CO	10. SPONSORING / MONITORING AGENCY REPORT NUMBER
--	--

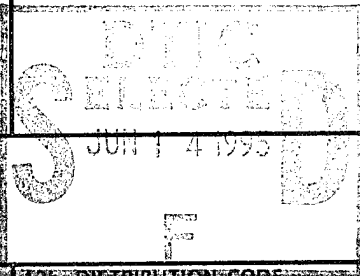

11. SUPPLEMENTARY NOTES	
-------------------------	--

12a. DISTRIBUTION / AVAILABILITY STATEMENT APPROVED FOR PUBLIC RELEASE; DISTRIBUTION IS UNLIMITED	12b. DISTRIBUTION CODE
--	------------------------

13. ABSTRACT (Maximum 200 words) VOL 1- GENERAL THIS IRA IS BEING CONDUCTED AS PART OF THE IRA PROCESS FOR THE RMA. THE LONG-TERM IMPROVEMENTS IRA CONSIST OF COMPLETION OF THE SHORT-TERM IMPROVEMENTS IRA AND IMPLEMENTATION OF MONITORING PROGRAM FOR THE ENTIRE NORTHWEST BOUNDARY SYSTEM, WITH NO MODIFICATION TO THE EXISTING TREATMENT PLANT. THE IMPLEMENTATION OF THE NWB SYSTEM LONG-TERM IMPROVEMENTS IRA IS INTENDED TO PROVIDE MONITORING DATA, CONSTRUCTION OF ADDITIONAL MONITORING WELLS (INCLUDING REVEGETATION OF AREAS DISTURBED DURING CONSTRUCTION) MONITORING BOTH TREATMENT PLANT AND AQUIFER WATER QUALITY, WATER-TABLE MONITORING, AND PREPARATION OF A REPORT CONTAINING AN EVALUATION OF SYSTEM PERFORMANCE BASED ON QUARTERLY MONITORING L-R ONE YEAR. VOL 2- ENGINEERING SPECIFICATIONS THIS SPECIFICATION COVERS THE CONSTRUCTION OF SEVEN NOMINAL 2- INCH DIAMETER ALLUVIAL MONITORING WELLS FOR MONITORING WATER-TABLE ELEVATION AND GROUNDWATER

14. SUBJECT TERMS IRA B, HEALTH AND SAFETY, SPECIFICATIONS, COST	15. NUMBER OF PAGES
	16. PRICE CODE

17. SECURITY CLASSIFICATION OF REPORT UNCLASSIFIED	18. SECURITY CLASSIFICATION OF THIS PAGE	19. SECURITY CLASSIFICATION OF ABSTRACT	20. LIMITATION OF ABSTRACT
---	--	---	----------------------------

IMPLEMENTATION DOCUMENT
FOR
NORTHWEST BOUNDARY SYSTEM
LONG-TERM IMPROVEMENTS
INTERIM RESPONSE ACTION

VOLUME 1 GENERAL

FINAL

January 1992

Prepared by
Morrison-Knudsen Corporation
Environmental Services Group
Denver, Colorado 80203

Prepared for
Shell Oil Company
Denver, Colorado 80203

TABLE OF CONTENTS

VOLUME I

<u>SECTION</u>	<u>PAGE</u>
1.0 INTRODUCTION.....	1
2.0 MEMORANDUM OF UNDERSTANDING.....	3
3.0 MONITORING PLAN.....	18
4.0 ESTIMATED COST AND BASIS OF THE ESTIMATE.....	27
5.0 SCHEDULE.....	29
6.0 HEALTH AND SAFETY PLAN.....	30

VOLUME 2

ENGINEERING SPECIFICATIONS

VOLUME 3

ENGINEERING DRAWINGS

1.0 INTRODUCTION

The Northwest Boundary System Long-Term Improvements Interim Response Action (IRA) is being conducted as part of the IRA process for the Rocky Mountain Arsenal (RMA).

On April 13, 1990, the Northwest Boundary System Improvements IRA was divided into the Short-Term Improvements IRA and Long-Term Improvements IRA. The Lead Role for completing the Northwest Boundary System Short-Term Improvements IRA was transferred from the Army to Shell on April 13, 1990, and included an assessment of the alluvial groundwater intercept system followed by detailed design and construction of both the Northeast Extension (Phase I) and Southwest Extension (Phase II). Phases I and II construction were completed in October 1990 and October 1991, respectively.

Concurrent with implementation by Shell of the Short-Term Improvements IRA, the Army completed an assessment for the Northwest Boundary System Long-Term Improvements IRA. The conclusion from this assessment is that the Long-Term Improvements IRA should consist of completion of the Short-Term Improvements IRA and implementation of a monitoring program for the entire Northwest Boundary System, with no modifications to the existing treatment plant. This recommendation is contained in the Draft Final Decision Document for Northwest Boundary System Long-Term Improvements IRA submitted by the Army to the Organizations and State on September 11, 1991 and finalized on October 3, 1991.

Since July 1991, Shell has assumed operation of the Northwest Boundary System, and the Army has proposed that the Lead Role for detailed design and implementation of the Northwest Boundary System Long-Term Improvements IRA be transferred to Shell. The

proposal was contained in a letter submitted by the Army to Shell on August 26, 1991.

The implementation of the Northwest Boundary System Long-Term Improvements IRA is intended to provide monitoring data sufficient to complete a comprehensive assessment of the operational effectiveness of the Northwest Boundary System. Specifically, the IRA will include construction of additional monitoring wells (including revegetation of areas disturbed during construction), monitoring both treatment plant and aquifer water quality, water-table monitoring, and preparation of a report containing an evaluation of system performance based on quarterly monitoring for one year. If appropriate, the evaluation will include any recommendations regarding additional improvements to the system.

A cost estimate and schedule have been prepared and are included. The estimated cost and schedule are based upon the assumption that the IRA will be complete at the time the annual performance report is submitted, following one year of monitoring. The cost of implementation is estimated to be \$440,000.00, and the basis of the estimate is given in Section 4.0. The deadline for completion of this project (an "IRA Deadline" under the Federal Facility Agreement) is July 1, 1993, subject to extension as described in Section XXVI of the Federal Facility Agreement. Intermediate dates shown in this document comprise the "Schedule" (as defined in the Federal Facility Agreement) and are not "Deadlines" under the Federal Facility Agreement.

MEMORANDUM OF UNDERSTANDING BETWEEN
THE DEPARTMENT OF THE ARMY AND SHELL OIL COMPANY
WITH RESPECT TO
RESPONSE ACTION WORK CONDUCTED PURSUANT TO THE
FEDERAL FACILITY AGREEMENT

I. PARTIES

This Memorandum of Understanding ("MOU") specifies the cooperative undertakings which are to occur between the Army (a potentially responsible party under CERCLA) and Shell (a potentially responsible party under CERCLA) with respect to any Scope of Work developed pursuant to the Federal Facility Agreement now or hereafter attached as an exhibit to this MOU.

II. PURPOSE

The purpose of this MOU is to provide an appropriate basis pursuant to the Federal Facility Agreement for Shell to participate in the expeditious (a) assessment, selection, design and implementation of an IRA or (b) operation and maintenance of any Response Action Structure.

III. DEFINITIONS

The following terms, used in the MOU, shall have the meanings indicated:

(a) "Army" means the United States Department of the Army, and any successors or assigns thereof, and any agency, office or other subdivision thereof; and includes the officers, members, employees and agents of the Army when acting within the scope of their authority.

(b) "Arsenal" means the United States property known as the Rocky Mountain Arsenal and described more particularly on Exhibit A hereto.

(c) "CERCLA" means the Comprehensive Environmental Response, Compensation and Liability Act of 1980, as amended by the Superfund Amendments and Reauthorization Act of 1986.

(d) "Contractor" means any commercial party not a part of Shell with which Shell contracts for the performance of Response Action work pursuant to this MOU. Unless otherwise indicated, the term also includes a subcontractor retained by a prime Contractor or another subcontractor.

(e) "Federal Facility Agreement" means the Federal Facility Agreement for Rocky Mountain Arsenal, effective February 17, 1989, including all exhibits thereto (and any amendments or modifications thereof or supplements thereto).

(f) "Financial Manual" means the document identified in paragraph 7.4 of the Settlement Agreement.

(g) "Force Majeure" means any event arising from causes beyond the control of an Organization that causes a delay in or prevents the performance of any obligation under this MOU. "Force Majeure" includes, but is not limited to: acts of God; fire; war; insurrection; civil disturbance; explosion; unanticipated breakage or accident to machinery, equipment or lines of pipe, despite diligent maintenance; adverse weather conditions which could not be reasonably anticipated; unusual delay in transportation; earthquakes; restraint by court order or order of public authority; inability to obtain, at reasonable cost and after exercise of reasonable diligence, any necessary authorizations, approvals, permits or licenses as a result of the action or inaction of any governmental agency or authority other than the Army; delays caused by compliance with applicable statutes or regulations governing contracting, procurement or acquisition procedures, despite the exercise of reasonable diligence; and insufficient availability of appropriated funds, if the Army shall have made timely request for such funds as part of the budgetary process. "Force Majeure" also includes any strike or labor dispute, whether or not within the control of the Organization affected thereby, but shall not include increased costs or expenses of Response Actions, whether or not anticipated at the time such Response Actions were initiated.

(h) "IRA" means an Interim Response Action identified in Section XXII of the Federal Facility Agreement.

(i) "Lead Party" means the Organization that is designated with responsibility, in accordance with Section XLIII of the Federal Facility Agreement, for conducting a Response Action, or any part thereof.

(j) "MOU" or "Memorandum of Understanding" means to this entire document and any amendments or modifications hereof and supplements hereto, and all documents incorporated herein by reference.

(k) "NCP" means the National Oil and Hazardous Substances Pollution Contingency Plan, 50 Fed. Reg. 47912 (1985) (effective February 18, 1986), and all amendments thereto which are not inconsistent with CERCLA and which are effective and applicable to any activity undertaken pursuant to this MOU.

(l) "Organization" means the Army, EPA or Shell.

(m) "Party" means the Army or Shell; "Parties" means the Army and Shell.

(n) "Response Action" has the same meaning as "Respond" or "Response" as defined in Section 101(25) of CERCLA, 42 U.S.C. § 9601(25).

(o) "Scope of Work" means a document identified in Part VI by which any Response Action work for which Shell is the Lead Party shall be conducted.

(p) "Settlement Agreement" means the "Settlement Agreement Between the United States and Shell Oil Company Concerning Rocky Mountain Arsenal," effective February 17, 1989, including all exhibits thereto (and any amendments or modifications thereof or supplements thereto).

(q) "Shell" means (a) Shell Oil Company and its successors and assigns, (b) the divisions thereof, including Shell Chemical Company, (c) Julius Hyman & Co., and (d) Shell Chemical Corporation; and includes the officers, employees and agents of Shell when acting within the scope of their authority.

All other capitalized terms used in this MOU shall have the same meaning as in the Federal Facility Agreement or the Settlement Agreement or the meaning specified in an executed Scope of Work.

IV. SCOPE OF MOU

This MOU, the Federal Facility Agreement and the Settlement Agreement constitute the entire understanding between the Army and Shell with respect to Shell's assisting the Army in the Response Action work described in an executed Scope of Work, except for any subsequently executed Scope of Work which the Parties may execute with respect to such Response Action work; constitute the sole conditions controlling Shell's participation in such Response Action work; and with respect to such Response Action work, supersede any other agreement(s) between the Parties. In the event a conflict between the provisions of the Federal Facility Agreement and the Settlement Agreement and this MOU, the provisions of the Federal Facility Agreement and the Settlement Agreement shall govern.

V. OPERATION OF MOU

By their execution of this MOU, each of the Parties acknowledges and agrees as follows:

(a) The provision of the Response Action work pursuant to this MOU is a reasonable and appropriate contribution to the assessment, selection, design and implementation of Response Actions that are protective of the present and future public health and the environment.

(b) The Army's actions under this MOU are not inconsistent with the NCP.

(c) Shell's actions under this MOU, to the extent certified by the Army pursuant to Subpart VI.E., are consistent with the NCP.

(d) This MOU does not operate to establish or to excuse any Shell or Army liability under any law, the Federal Facility Agreement or the Settlement Agreement, except to the extent provided in this MOU.

(e) This MOU does not operate to render Shell or any of its Contractors a CERCLA response action contractor.

(f) This MOU does not operate to expand or limit any of the rights and obligations of the Army as Lead Agency or Shell as Lead Party under any law or the Federal Facility Agreement.

(g) Unless otherwise provided in a Scope of Work, upon acceptance of the Response Action work pursuant to Subpart VI.E, title to any Response Action Structure including all related systems and facilities constructed as a part of that Response Action work shall pass to the United States.

(h) The Army shall be solely responsible for obtaining necessary permits, if any, and for establishing substantive compliance with all permitting requirements pursuant to Section 121(e) of CERCLA, 42 U.S.C. 9621(c), for any activities conducted pursuant to this MOU. However, Shell shall provide any necessary technical support necessary for the Army to obtain such permits.

(i) This MOU has no precedential or controlling effect with respect to any matter which is not expressly the subject of this MOU.

(j) This MOU does not create or impose any obligations or responsibilities on the Parties or relieve them of any obligations or responsibilities, except to the extent expressly provided herein.

VI. SHELL'S PERFORMANCE OF RESPONSE ACTION WORK

A. Development of Scope of Work: Pursuant to Section XLIII of the Federal Facility Agreement, the Army and Shell shall develop Scopes of Work by which Response Action Work for which Shell is the Lead Party shall be conducted. A Scope of Work shall include any required data or specifications for the Response Action work to be performed, a projected schedule for completion and a statement as to the appropriate limits of insurance to be maintained by Shell pursuant to Part VII.

B. Incorporation into this MOU: Any Scope of Work developed pursuant to Subpart VI.A and executed by the Army and Shell, and all the terms and conditions therein are incorporated by reference into this MOU.

C. Performance of Work: Upon execution of the Scope of Work by the Army and Shell, Shell shall immediately commence, in consultation and cooperation with the Army, as provided in the Consent Decree, to perform the Response Action work described in the Scope of Work.

D. Hiring of Contractor: Subject to the approval of the Army, Shell may hire at its sole expense, subject to Part VII, a Contractor to perform any Response Action work described in a Scope of Work. A Contractor may be terminated by Shell with the approval of the Army, which approval shall not be unreasonably withheld. Any disagreement with respect to such termination not resolved informally shall be resolved in accordance with the provisions of Part XIII.

E. Acceptance of Work: 1. If Shell performs the Response Action work in accordance with the specifications set forth in the applicable Scope of Work, the Army shall accept Shell's work pursuant to this MOU. The Army shall act promptly to accept Shell's work, and acceptance shall not be unreasonably withheld. Should the Army decline acceptance, it shall promptly notify Shell in writing, stating with specificity the factual, technical and legal bases for such nonacceptance.

2. If Shell concludes that the Army is in error for treating Shell's performance as incomplete or unacceptable for any other reason, Shell shall give notice in writing, within ten business days of the receipt of the Army's written notification, that Shell disagrees. Any such disagreement, if not resolved informally, shall be resolved in accordance with the provisions in Part XIII.

VII. SHELL INSURANCE OBLIGATIONS

Shell shall maintain such insurance or self-insurance as is required by statute or regulation to cover any claims which may reasonably be anticipated to be made as a result of Response Action work done pursuant to any Scope of Work attached as an exhibit to this MOU. At a minimum, Shell shall, at its sole option, procure insurance, maintain insurance or self-insure sufficiently to cover the following:

1. Worker's compensation and occupational disease insurance in amounts sufficient to satisfy applicable state law;
2. Employer's liability insurance in the minimum amount of \$100,000 per occurrence; and
3. Comprehensive general liability insurance for bodily injury, death or loss of or damage to property of third persons in the minimum amount of \$100,000 per occurrence.

Upon this MOU becoming effective, Shell shall promptly provide the Army with an affidavit that Shell is in compliance with the minimum requirements of this Part. Upon the signing of a Scope of Work, Shell shall promptly provide the Army with an affidavit that Shell is in compliance with this Part as to that Scope of Work. Upon request, Shell shall discuss with the Army the manner in which Shell will fulfill its obligations under this Part.

VIII. ARMY SUPPLEMENTATION OF SHELL INSURANCE

If the Response Action work being performed is an Army-Only Response Action, as defined in the Settlement Agreement, the Army shall release, defend, indemnify and hold harmless Shell from all losses, fines, penalties, claims, suits, liabilities, judgments, or expenses (including expenses of litigation or settlement) (collectively hereinafter in this Part VIII, "claim") with respect to any death or injury to any person or loss of or damage to property to the extent that these result from the construction, operation, collapse, rupture or failure of any Response Action Structure, or any part thereof, after the Army's acceptance pursuant to Subpart VI.E. or the operation, collapse, rupture, failure or ineffectiveness of the Response Action Structure as a result of the construction, operation, collapse, rupture or failure of the Response Action work when such claim is not compensated by insurance or self-insurance, to the extent provided below:

- (a) Shell is not in material breach of this MOU with respect to the Scope of Work pursuant to which such Response

Action work was performed or such Response Action Structure was constructed;

(b) Any claim which is within the deductible amounts of Shell's insurance shall not be subject to this Part;

(c) Shell shall not be reimbursed for any claims (including expenses incidental to such claims) to the extent that they result, in whole or in part, from willful misconduct or recklessness by Shell;

(d) The Army may discharge its obligations under this Part by making payments directly to Shell or directly to any party to whom Shell may be liable upon obtaining a release from that party, which release provides adequate protection for Shell.

(e) If insurance coverage maintained in accordance with Part VII is reduced below the minimums specified in that Part without the Army's knowledge or approval, the liability of the Army under this MOU shall not be increased by reason of such reduction;

(f) To the extent that any claim against Shell may reasonably be expected to involve indemnification under this Part, Shell shall:

(1) promptly notify the Army of such claim against Shell;

(2) furnish evidence or proof of any claim covered by this Part in the manner and form reasonably requested by the Army; and

(3) immediately furnish the Army with copies of all pertinent papers received by Shell.

(g) To the extent that the amount of the claim is not determined to be in excess of the limits set forth in Part VII or to the extent that the amount of the claim cannot reasonably be determined to be or not to be in excess of those limits, Shell and the Army shall conduct a joint defense or settlement. Once it is determined that the amount of the claim is in excess of the limits set forth in Part VII, the Army shall direct and control such defense or settlement, with assistance by Shell as is acceptable to both Parties, and Shell shall execute any authorizations which the Army reasonably requires in connection with such settlement.

(h) Reimbursement for any claims under this Part shall not exceed appropriations available during the time that

such claims are represented by final judgments or by settlements approved in writing by the Department of Justice. This agreement to reimburse Shell for certain claims shall not be interpreted as implying that Congress shall, at a later date, appropriate funds sufficient to meet any deficiencies. During all times that claims remain unreimbursed due to lack of appropriated funds, the Army shall exert its best efforts to obtain appropriations for such reimbursement.

**IX. TREATMENT OF COSTS INCURRED
BY SHELL PURSUANT TO THIS MOU**

Any costs incurred by Shell pursuant to this MOU are Reimbursable Costs and shall be governed by the Settlement Agreement and the Financial Manual.

X. DELAY OR PREVENTION OF PERFORMANCE

A. As provided in the Consent Decree, if a Party is rendered unable, wholly or in part, by Force Majeure to carry out its obligations under this MOU, then upon that Party's giving written notice as provided in Subpart XI.C., the obligations of that Party, so far as they are affected by the event of Force Majeure therein specified, shall be suspended during the continuance of such cause, but for no longer period, and such cause shall be remedied so far as possible with all reasonable dispatch.

B. The settlement of a strike or other labor dispute shall be entirely within the discretion of the Party involved with such strike or labor dispute, and the requirement that any event of Force Majeure shall be remedied with all reasonable dispatch shall not require the settlement of a strike or labor dispute by acceding to the demands of the opposing party when such course is inadvisable in the discretion of the Party involved with such strike or labor dispute.

C. When circumstances are occurring or have occurred that delay the completion of any obligation, and a Party believes such circumstances constitute an event of Force Majeure, such Party shall notify the other Organizations in writing within 15 days after the notifying Party obtains information indicating that a delay will occur. Such notice shall include a detailed explanation of the reason(s) for and anticipated duration of the delay, the measures taken and to be taken to prevent or minimize the delay, and a schedule for implementation of such measures. Failure to provide notice in accordance with this paragraph within the required 15-day period shall constitute a waiver of any claim of Force Majeure with respect to any event of Force Majeure for which notice was not timely given.

D. If the Organizations cannot agree whether a delay is or was attributable to an event of Force Majeure, any Organization may invoke Dispute Resolution pursuant to Section X of the Settlement Agreement.

E. Scope of Work Modification: If performance of this MOU is delayed because any Party finds it necessary to make modifications to address an unanticipated occurrence which may cause a delay of more than two weeks, such modifications shall be developed and implemented by Shell in consultation and cooperation with the Army. Any disputes not resolved informally shall be resolved pursuant to the provisions of Part XIV. Further, if Shell anticipates the delay resulting from any such modifications will necessitate the extension of a Deadline, it shall request such an extension in accordance with Section XXVI of the Federal Facility Agreement.

F. Unaffected Activities: To the extent that the unanticipated occurrence does not necessitate delay in any discrete portion(s) of the activities provided in Part VI, such portion(s) of the activities shall proceed as originally provided in the MOU irrespective of the need for modification of other parts of the MOU.

XI. SHELL ACCESS TO ROCKY MOUNTAIN ARSENAL

Shell and its Contractors shall be afforded access to all relevant portions of the RMA in order to perform its obligations under the MOU pursuant to the terms and conditions of the Access and Use Agreement attached as Exhibit E to the Settlement Agreement until such time as the Army and Shell execute an applicable superseding agreement.

XII. DISPUTE RESOLUTION AND JUDICIAL REVIEW

A. Dispute Resolution: Any dispute which arises in connection with this MOU may be submitted for resolution pursuant to Section X of the Settlement Agreement. Prior to any such submission, Shell and the Army shall meet and attempt to resolve the dispute informally.

B. Judicial Review: 1. Judicial review of issues arising in connection with this MOU shall be obtained pursuant to Section XI of the Settlement Agreement.

2. The pendency of any dispute shall not affect the responsibility of the United States or Shell to continue their involvement in the assessment, selection, design and implementation of Response Actions, or discrete portions of Response Actions, not subject to such dispute.

XIII. GENERAL

A. Term: This MOU shall continue in effect as to a specific Scope of Work until the Army, pursuant to Subpart VI.E., accepts Shell's work pursuant to this MOU, and the reimbursement or payment has been made pursuant to Part IX.

B. Modification: Any provision of this MOU or of any Scope of Work may be modified at any time by both Parties' agreement. Any modification must: (1) be in writing; (2) show the date signed by the Parties; (3) specify that it is intended to modify this MOU; (4) state the provisions of the MOU to be modified; (5) state the new provisions; and (6) state when the new provisions are to be effective.

C. Effect of Execution: This MOU shall become effective on the later of its execution by the Parties or the entry of the Consent Decree. A Scope of Work shall become effective, final and binding upon its execution.

IN WITNESS WHEREOF, I have hereunder set my hand as an authorized representative of the United States Department of the Army.

Date: _____

1/23/89

Lewis D. Walker

Lewis D. Walker
Deputy for Environment, Safety
and Occupational Health

IN WITNESS WHEREOF, I have hereunder set my hand as an authorized representative of Shell Oil Company.

Date: _____

R.G. Dillard
Vice President

XIII. GENERAL

A. Term: This MOU shall continue in effect as to a specific Scope of Work until the Army, pursuant to Subpart VI.E., accepts Shell's work pursuant to this MOU, and the reimbursement or payment has been made pursuant to Part IX.

B. Modification: Any provision of this MOU or of any Scope of Work may be modified at any time by both Parties' agreement. Any modification must: (1) be in writing; (2) show the date signed by the Parties; (3) specify that it is intended to modify this MOU; (4) state the provisions of the MOU to be modified; (5) state the new provisions; and (6) state when the new provisions are to be effective.

C. Effect of Execution: This MOU shall become effective on the later of its execution by the Parties or the entry of the Consent Decree. A Scope of Work shall become effective, final and binding upon its execution.

IN WITNESS WHEREOF, I have hereunder set my hand as an authorized representative of the United States Department of the Army.

Date: _____

Lewis D. Walker
Deputy for Environment, Safety
and Occupational Health

IN WITNESS WHEREOF, I have hereunder set my hand as an authorized representative of Shell Oil Company.

Date: _____

2/15/89

R.G. Dillard

R.G. Dillard
Vice President

SCOPE OF WORK

Shell will perform the following activities as lead party for implementation of the Northwest Boundary System Long-Term Improvements IRA.

1. Prepare both the Draft and Final Implementation Documents for Northwest Boundary System Long-Term Improvements IRA for review and approval by the Army and implement the IRA.
2. Execute the detailed work plan for the selected response action, which will include the following:
 - a. Construction of seven additional alluvial ground-water monitoring wells; five located in the vicinity of the new extraction and recharge well fields constructed under the Short-Term Improvements IRA, one located in the reinjection well field north of the NWBS treatment plant, and one located offpost downgradient of the reinjection well field. This activity will include revegetation of areas disturbed during well construction. In an effort to reduce long-term maintenance activity, areas that would require mowing will be seeded solely with short grass species.
 - b. Water-table monitoring, including collecting and evaluating water-level data from 165 wells (including 7 new wells) at a quarterly frequency.
 - c. Water-quality monitoring of the alluvial aquifer, involving collection and evaluation of data utilizing:

- 10 extraction wells (even-numbered) monitored for the presence of dibromochloropropane (DBCP), dicyclopentadiene (DCPD), diisopropylmethyl phosphonate (DIMP), trichloroethene (TRCLE), organochlorine pesticides (OCPs), and total trihalomethanes (THMs) at a semi-annual frequency;
 - 38 monitoring wells and 10 extraction wells (odd-numbered) monitored for the presence of the above-referenced compounds at a quarterly frequency; and
 - 12 monitoring wells monitored for the presence of OCPs at a quarterly frequency.
- d. Water-quality monitoring within the treatment plant, involving collection and evaluation of data utilizing:
- Plant influent and effluent sampled quarterly for all six analyte groups listed under Item 2.c;
 - Plant influent sampled annually for RMA target analytes and GC/MS unknowns; and
 - Plant effluent sampled annually for RMA target analytes, GC/MS unknowns, metals, and anions.
- e. Periodic review of program results to assess adequacy of the monitoring network, including preparation of a report containing a one-year evaluation of overall system performance.

3. Perform all work required for the implementation of the Northwest Boundary System Long-Term Improvements IRA as described more fully in the Implementation Document for Northwest Boundary System Long-Term Improvements IRA (within which this scope of work is included), including the following:
 - a. Procure all required materials and subcontractors.
 - b. Provide supervisory and construction labor to manage subcontractors for the installation of wells, revegetation of areas disturbed during construction, and laboratory analyses of samples collected.
 - c. Perform activities described in this paragraph 3 in accordance with the work plan, basis of the estimated cost, schedule, technical specifications, drawings, and health and safety requirements set forth in the Implementation Document for Northwest Boundary System Long-Term Improvements IRA.
4. Shell has contracted with Morrison-Knudsen Corporation (MK) for performance of Items 1, 2, and 3 above and any approved modifications thereto.
5. Shell will submit forty (40) copies of the Draft Implementation Document for Northwest Boundary System Long-Term Improvements IRA to the Army. Within 5 working days, the Army will issue these copies to the Organizations and State. Following a period of review, a meeting will be held to discuss comments regarding the document. Shell will submit forty (40) copies of the Final Implementation Document for Northwest Boundary System Long-Term Improvements IRA to the Army

within 20 working days of the meeting. The Army will distribute the document to the Organizations and State within 5 days of receipt from Shell.

6. During performance of the monitoring plan for this Interim Response Action, Shell shall submit letter progress reports to the Army summarizing work performed versus work planned, highlighting major items completed, and updating the schedule until the Interim Response Action is completed. Reports will be submitted on a monthly basis during construction, and thereafter on a quarterly basis following each sampling event. Monthly letter reports shall be submitted to the Army within ten (10) working days after the end of each month. At the close of the project, a letter will be provided to the Army summarizing the work completed.

IN WITNESS WHEREOF, I have hereunder set my hand as an authorized representative of the United States Department of the Army.

Date November 18, 1991

Kevin T. Blase
Deputy Program Manager

IN WITNESS WHEREOF, I have hereunder set my hand as an authorized representative of Shell Oil Company.

Date November 6, 1991

W. M. Kinney
Manager Projects, Denver Site
Project

3.0 MONITORING PLAN

1. Survey: The locations of proposed new monitoring wells will be surveyed prior to construction, with as-built location and elevations surveyed following construction.
2. Health and Safety Monitoring: The general nature of subsurface contamination has been characterized from previous investigations in the Northwest Boundary System area, and is reflected in the protective measures outlined in the Task Specific Health and Safety Plan.

All construction and subsequent quarterly monitoring activities will be monitored by Health and Safety personnel. Should results of Health and Safety monitoring warrant further investigations, additional testwork will be implemented.

3. Monitoring Program:

- A. Treatment Plant Monitoring

The treatment plant monitoring program consists of the collection of water samples for chemical analysis, and the collection of plant information such as flowrates and carbon inventory. These data are combined to assess the operating effectiveness of the treatment plant. The treatment plant monitoring program is not meant to be static in nature. Modifications to this program may be required based on operational and analytical observations. Evaluations of this program will be performed periodically and changes will be made as necessary. Any modifications to the treatment plant monitoring program will be reported to the Organizations and State.

In order to obtain data which are compatible with previous Army sampling schedules, quarterly plant influent and effluent samples will be obtained and analyzed. The first six compounds or compound groups listed in Table 3-1 will be the target analytes for the quarterly influent and effluent sampling. Table 3-2 indicates the sample locations, sample identifications, and analytical methods for the quarterly sampling program.

TABLE 3-1

Monitoring Program Analyte List

Dibromochloropropane (DBCP)
 Dicyclopentadiene (DCPD)
 Diisopropylmethyl phosphonate (DIMP)
 Organochlorine Pesticides (OCPs)
 Trichloroethene (TRCLE)
 Trihalomethanes (THMs)
 RMA Target Analytes
 GC/MS unknowns
 Metals
 Anions

TABLE 3-2

Quarterly Water-Quality Sampling Program

<u>Sample Location</u>	<u>Sample ID</u>	<u>Analytical Method</u>
Plant Influent	PWININ ¹	PMRMA
Plant Effluent	PWEFEF	PMRMA

Notes:

¹Plant influent samples can be obtained from any influent tap on an operational adsorber, upstream of the prefilters.

To provide a complete view of the water quality at the NWBS, samples will be obtained once per year for the plant influent and effluent. The annual sampling from the adsorber ports will be the same as for quarterly sampling. Sampling from the influent/effluent is detailed in Table 3-3. PMRMA procedures will be used in this part of the sampling program.

TABLE 3-3

Annual Water-Quality Sampling Program

<u>Sample Location</u>	<u>Compounds</u>
Influent (PWININ)	Organic RMA target analytes, GC/MS unknowns
Effluent (PWEFEF)	RMA target analytes, GC/MS unknowns, Metals ¹ , Anions ²

Notes:

¹Metals = Cd, Cr, Cu, Pb, Zn, As, Hg, Se

²Anions = F, Cl, NIT (NO₃ + NO₂), SO₄

B. Aquifer Monitoring

The NWBS well monitoring program includes water-table monitoring and water-quality monitoring both on a quarterly and semi-annual basis. Additional monitoring will be conducted, as required, in response to operational changes or events such as an extended system shut-down. Since the distribution of groundwater contaminants is expected to change as the modifications made during the Short-Term Improvements IRA influence contaminant migration, the monitoring

program is intended to be flexible and will be revised when conditions warrant.

1. Water-Table Monitoring

Water-level measurements will be taken in 165 wells each quarter just prior to commencing the well sampling program. Water levels in 84 wells located near the NWBS, indicated as List 1 on Table 3-4, will be measured within one day to minimize the effect of variation in operation of the main system on the mapped water-table surface. All 165 wells shown in Lists 1 and 2 on Table 3-4 and shown on the drawings will be measured within a maximum of two consecutive days. Fifteen monitoring wells are located offpost. The Army has obtained long-term access agreements for these wells.

2. Water-Quality Monitoring

Groundwater samples will be collected from the extraction and monitoring wells at the frequencies and for the analytes indicated on Table 3-5. The locations of wells are shown on the drawings. Of the 20 extraction wells, the 10 odd-numbered extraction wells will be sampled during each quarter. The 10 even-numbered extraction wells will be sampled during only the second and fourth quarters. All three new extraction wells in the southwest extension may not be operated at once; therefore, samples will be collected from only those wells that are normally in operation. All

TABLE 3-4

Water-Table Monitoring Program

List 1 Wells

List 2 Wells

22003	22511*	22001	27518
22004		22011	27519
22005	27002	22049	27521
22007	27004	22054	27522
22008	27005	22082	27523*
22009	27006		27524*
22010	27007	27003	27525*
22015	27010	27008	27526*
22016	27011	27009	27527*
22017	27045	27037	
22018	27062	27042	28002
22019	27063	27043	28003
22021	27064	27044	28004
22034	27065	27053	28005
22035	27066	27056	28006
22036	27068	27059	28007
22040	27069	27072	28008
22042	27070	27073	28009
22043	27071	27074	28011
22044	27085	27075	28012
22045	27086	27076	28013
22051	27089	27077	28022
22052	27090	27078	28023
22053	27502	27079	28519
22056	27503	27080	28520
22057	27504	27083	
22059	27520	27088	37334
22060		27091	37335
22061	37330		37382
22062	37331	27318	37385
22063	37332	27319	37436
22064	37333	27320	37437
22065	37386		37438
22066	<u>37600*</u>	27422	37439
22067	84 Wells	27423	<u>37441</u>
22069		27424	81 Wells
22070		27425	
22071			<hr/> 165 Total
22072		27501	Wells
22073		27505	
22075		27506	*New monitoring
22076		27507	well proposed
22077		27508	as part of the
22078		27509	IRA.
22081		27510	
22501		27511	
22502		27512	
22504		27513	
22505		27514	
22506		27515	
22507		27516	
22508		27517	

50 monitoring wells listed on Table 3-5 will be sampled each quarter initially. The number may be reduced when the effects of the IRA modifications have been demonstrated and the system has stabilized.

Since dieldrin is the only contaminant present in the vicinity of the southwest extension, OCPs will be the only analyte group sampled from selected wells within this plume. The new extraction wells and two monitoring wells upgradient of the new extraction wells will be sampled for the complete analyte list. Table 3-5 specifies the 12 monitoring wells in which OCPs are the only analyte group of interest.

Wells located west of the western edge of the primary contaminant plume will be used to monitor the potential westward migration of any additional contaminants.

4. Hydrogeological Services: A hydrogeologist (or designee) will be onsite to log information on borehole lithology and well construction. The hydrogeologist will also manage all monitoring activities under the IRA following submittal of the Final Implementation Document.
5. Revegetation Management: A natural resources specialist will be onsite to supervise soil preparation, seeding, and mulching in areas disturbed by well construction.

TABLE 3-5

Aquifer Water-Quality Monitoring Program

EXTRACTION WELLS

List 1-Extraction Wells Sampled Quarterly--ANALYTE LIST SHOWN BELOW

22301	22311
22303	22313
22305	22315
22307	22317
22309	<u>27319</u>

10 Wells

List 2 - Extraction Wells Sampled During the Second and Fourth Quarters -- ANALYTE LIST SHOWN BELOW

22302	22312
22304	22314
22306	22316
22308	27318
22310	<u>27320</u>

10 Wells

MONITORING WELLS

List 3 - Monitoring Wells Sampled Quarterly -- ANALYTE LIST SHOWN BELOW EXCEPT WHERE NOTED ¹OCPs ONLY

22010	27526* ¹	Note: ¹ OCP analysis only
22015	27527* ¹	
22016		
22017	28002 ¹	*New monitoring well proposed as part of the IRA.
22018	28003 ¹	
22019	28519 ¹	
22021	28520 ¹	
22059		<u>ANALYTE LIST</u>
22501	37330	
22507	37331	DBCP
22508	37332	DCPD
	37333	DIMP
27003	37334	OCPs
27005	37335	TRCLE
27010	37382	THMs
27053	37385	
27072	37386	
27085	37436 ¹	
27086	37437 ¹	
27091	37438	
27502	37439	
27503	<u>37600*</u>	
27504	50 Wells	
27505 ¹		
27517		
27519		
27520		
27521		
27522 ¹		
27523* ¹		
27525* ¹		

6. Health and Safety: A Health and Safety representative will be onsite to monitor well construction and follow-up monitoring activities to ensure worker's safety and health and identify the presence of any potentially hazardous compounds that may be encountered.
7. Quality Assurance/Quality Control (QA/QC): Periodic field surveillance of construction and subsequent monitoring activities will be performed by QA/QC personnel, with audits performed by the project QA/QC management.
8. Reporting: The Construction Manager shall prepare Daily Construction Reports during well construction to record field activities. Separately, a daily personnel log shall be used to record the names of all personnel who have visited the site. As described in Section 2.0, work summaries will be presented to the Army on a regular basis.
9. Organization: An organization chart for construction and monitoring under the Northwest Boundary System Long-Term Improvements IRA is attached.

Organization Chart

Northwest Boundary System Long-Term Improvements IRA

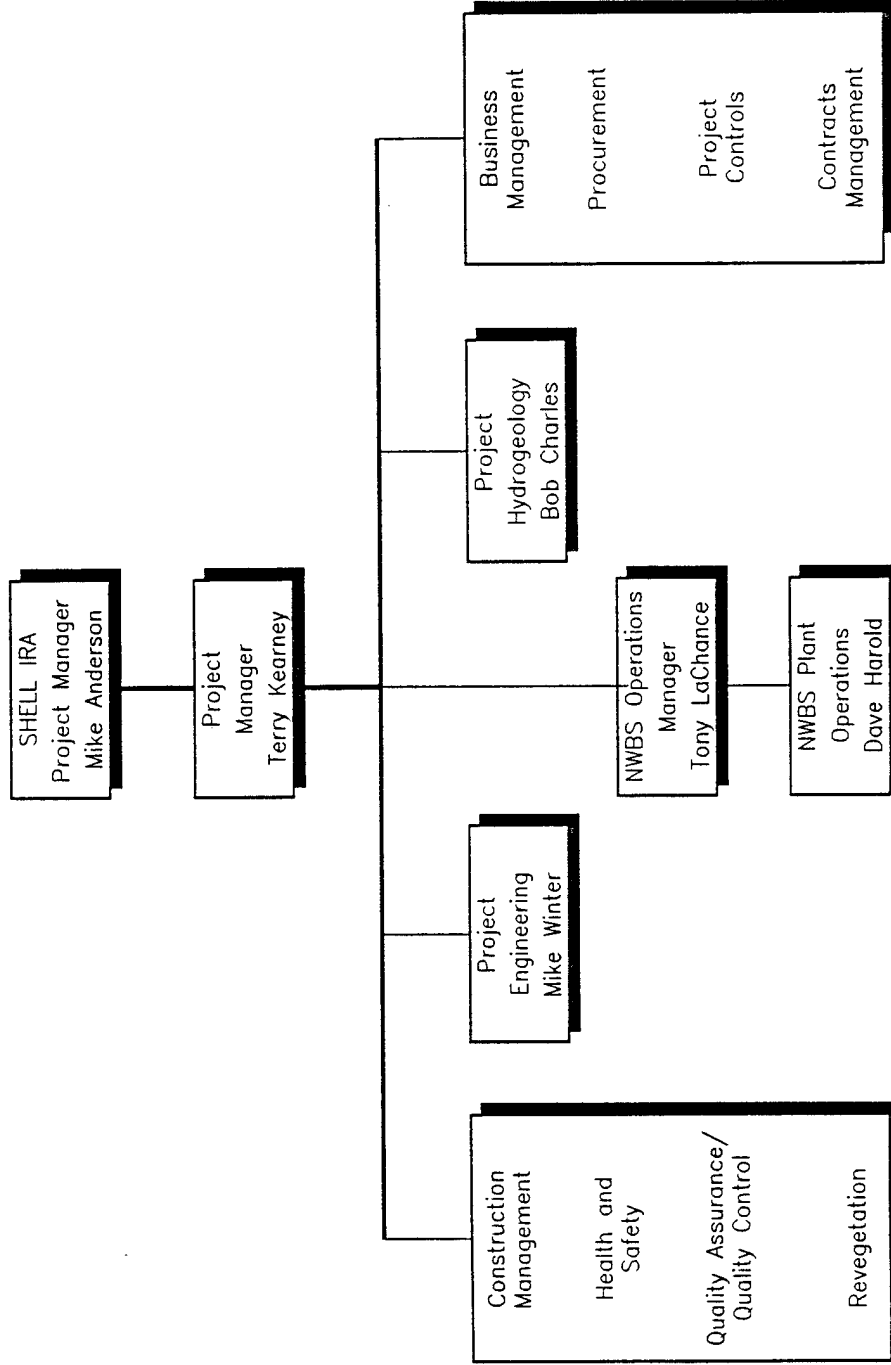

4.0 ESTIMATED COST AND BASIS OF THE ESTIMATE

The Cost Estimate Summary shown below has been prepared for implementation of the Northwest Boundary System Long-Term Improvements IRA, as represented on the schedule shown in Section 5.0. Included in the estimated costs are the monitoring-well construction and development, water-table monitoring, water-quality monitoring, and preparation of a one-year system performance report.

All activities are defined in the enclosed specifications (Volume II) and drawings (Volume III). The subject specifications and drawings are issued as part of this Implementation Document for Northwest Boundary System Long-Term Improvements IRA.

Subcontract labor costs are based on the prevailing merit shop wage rates in Adams County, Colorado. Contractor labor costs are based upon the average hourly billing rate of program personnel applied to total labor hours. Prices for permanent materials and services are based upon verbal quotations, written bids for recent site work, and current contract price agreements. Prices for such items as analytical services are subject to change.

Indirect costs for program management, Contractor's tools and consumables, overhead and fee, and contingency are also included in the estimate. The estimate has been prepared on the basis of Morrison-Knudsen Corporation acting as program manager for Shell Oil Company and subcontracting work including well construction, revegetation, and laboratory analytical services.

For the development of costs for health and safety supplies as well as labor productivity estimates, it was assumed that all work will be performed with Level D personnel protection as tabulated in Section 6.0.

COST ESTIMATE SUMMARY

1.	Wells Construction and Development (including revegetation)	\$ 25,000
2.	Water-Table Monitoring	7,500
3.	Water-Quality Monitoring	270,000
4.	Annual Report-Support	<u>4,500</u>
	SUBTOTAL	\$307,000
5.	Program Management, Overheads and Fees	<u>93,000</u>
	SUBTOTAL	\$400,000
6.	Contingency	<u>40,000</u>
	PROGRAM TOTAL	\$440,000

1.0 INTRODUCTION/SCOPE

This Task-Specific Health and Safety Plan (TSHSP) provides the basis for performing the Northwest Boundary System Long-Term Improvements Interim Response Action in a way that will control and minimize the risk to the health and safety of MK and subcontractor personnel. The plan defines the specific requirements and protocols for the protection of personnel performing the work.

Applicability of the TSHSP extends to all MK employees, subcontractors, and site visitors under MK's control. This work will be performed in accordance with the MK RMA Project Safety and Health Program, the RMA Site Health and Safety Plan, the MK-Ferguson Safety Manual, and all federal occupational health and safety rules and regulations.

This TSHSP will be reviewed by all MK and subcontractor personnel involved with the task prior to performing the work.

2.0 HAZARD ASSESSMENT

2.1 Chemical Hazards

Historical information indicates that the following chemical compounds have been detected in the groundwater in the area that the work will be performed.

<u>Chemical</u>	<u>PEL</u>
Aldrin	0.25 mg/m ³ (skin)
Chloroform	2 ppm
Dieldrin	0.25 mg/m ³ (skin)

Dicyclopentadiene	5 ppm
Diisopropylmethyl phosphonate	None established
Endrin	0.1 mg/m ³ (skin)
Isodrin	None established
Trichloroethene	50 ppm

Aldrin, chloroform, and dieldrin are considered potential occupational carcinogens by NIOSH.

The concentrations of these chemicals in the groundwater pose a small potential exposure risk to personnel involved with activities that may involve contact with the groundwater. It is anticipated that the primary potential exposure risk is respiratory. Although a few of the detected compounds can be absorbed through the skin and mucous tissues, the detected concentrations are far below the levels generally associated with adverse effects. However, a potential cutaneous exposure risk may be present if previously undetected substances are present or known constituents are present in higher concentrations than previously detected.

Concentrations of volatile organic compounds may accumulate in confined spaces. Organic compounds may be further volatilized by disturbance of contaminated groundwater. Dispersion of the volatile organic compounds is anticipated to occur in the ambient air before reaching the breathing zone of personnel.

The symptoms of exposure to the chemicals known to be present in the groundwater are similar although the concentrations which produce the symptoms may vary.

Volatile organic materials produce odors particular to each compound, and the detection of any unusual odors should be considered an indication of potential exposure through inhalation. Medical symptoms produced generally depend upon the extent of exposure. Initial symptoms include irritation of the mucous membranes of the nose and throat, eye irritation, headache, nausea and dizziness. Long-duration exposure to low concentrations, or acute exposures to high concentrations of contamination may produce weakness, vomiting, abdominal pain and central nervous system impairment (manifested by tremors, numbness in the limbs, lack of coordination, or unconsciousness). Long-term toxic effects are documented for many of the compounds although target organs and symptoms are varied and specific for each compound.

2.2 Physical Hazards

Physical hazards related to this task include personnel working with or in close proximity of heavy equipment, use of power tools, falling objects, and heat stress. Personnel need to be cognizant that the use of personal protective equipment may reduce dexterity and visibility and increase the difficulty of performing some tasks. Physical hazards may be controlled through the use of equipment guards, work practices, and training. Only equipment that is used for its intended task and that is in safe operating condition will be used. Personnel will be trained in the proper use and safe operation of the tools and equipment they utilize.

3.0 TRAINING

All personnel performing fieldwork for this task will have completed the forty (40) hour hazardous waste operations health and safety training pursuant to 29 CFR 1910.120(e) before beginning work. Eight (8) hour annual refresher training is required as necessary. The MK Construction Manager and subcontractor supervisors are required to have completed eight (8) hour Hazardous Waste Operations Supervisor/Manager training prior to the beginning of fieldwork.

Task/site specific training regarding the following topics will be given to all personnel performing fieldwork:

- Name of Site Safety and Health Supervisor and alternate.
- Safety and Health hazards related to this task.
- PPE requirements.
- Work practices.
- Hazard control.
- Medical surveillance requirements, including recognition of signs and symptoms which might indicate overexposure to chemical hazards.
- Decontamination procedures.

- Emergency response.
- Confined space entry procedures.

4.0 MEDICAL SURVEILLANCE

The basic requirements of the RMA Project Medical Surveillance Program shall apply to implementation of this task. No additional medical surveillance requirements are necessary.

5.0 PERSONAL PROTECTIVE EQUIPMENT (PPE)

The PPE to be utilized during NWBS Long-Term Improvements is dependent upon the specific task to be performed, the potential for contacting potentially contaminated soils or groundwater, and the concentration of air contaminants in the breathing zone of project personnel. The following PPE will be utilized (modified, as necessary, by the level of air contaminants measured in the breathing zone or at the discretion of the Site Health and Safety Officer).

<u>Task</u>	<u>PPE Level</u>
Monitoring Well Construction	Level D
Water-Level Measurements - Wells	" "
Groundwater Sampling - Wells	" "
Treatment Plant Sampling	" "

5.1 Level D Personal Protective Equipment:

- PVC/Polyurethane steel-toed boots
- Cotton Coveralls

- Hard hats
- Safety glasses with side shields
- Gloves

5.2 Level C Modified Personal Protective Equipment:

- PVC/Polyurethane steel-toed boots
- Cotton Coveralls (inner)
- Polyethylene-coated Tyvek coveralls (outer)
- Hard hats
- Safety glasses with side shields
- Latex gloves (inner)
- Nitrile gloves (outer); leather gloves may be worn outside of the nitrile gloves, but must remain on site at all times and be disposed of with other disposable clothing at the conclusion of the task.

5.3 Level C Personal Protective Equipment:

- PVC/Polyurethane steel-toed boots
- Cotton Coveralls (inner)
- Polyethylene-coated Tyvek coveralls (outer)

-
- Hard hats
 - Latex gloves (inner)
 - Nitrile gloves (outer); leather gloves may be worn outside of the nitrile gloves, but must remain on site at all times and be disposed of with other disposable clothing at the conclusion of the task.
 - Full-face air-purifying respirator with GMC-H cartridges (or equivalent).

6.0 SAMPLING/MONITORING

Sampling/monitoring will be performed to assess the exposure of personnel to hazardous materials and substances and to ensure that the proper level of personal protective equipment has been selected. Monitoring will also be conducted to delineate areas where protection is needed.

Real-time air monitoring will be performed using direct-reading instruments. Direct-reading instruments will be calibrated daily before use according to the manufacturer's instructions. The following table describes the appropriate response action for the detection of organic vapors. A flame-ionization detector (Foxboro Century OVA-128 or equivalent) will be used to monitor organic vapors. Monitoring will be performed periodically, as necessary.

Concentration in Breathing Zone*

Required Response

Less than 1 ppm

- 1) Level D or Modified Level C PPE.
- 2) Continue monitoring, as necessary.

Greater than 1 ppm,
Less than 20 ppm

- 1) Upgrade to Level C PPE
- 2) Increase frequency of monitoring.
- 3) Determine extent of airborne levels, modify extent of exclusion zones as necessary.

Greater than 20 ppm

- 1) Cease disturbing contaminated material, evacuate area.
- 2) Notify Construction Mgr. and H&S Mgr.
- 3) Determine extent of airborne levels, modify extent of exclusion zones as necessary.

*For five consecutive minutes; these levels are concentrations above background.

Personal air sampling using NIOSH or OSHA methodology will be performed at the discretion of the Site Health and Safety Officer.

7.0 SITE CONTROL

An exclusion zone will be established for each task where Level C-Modified PPE (or greater) is required. Entry into the exclusion zone is restricted to those personnel wearing the appropriate personal protective equipment. For the task of well drilling, the exclusion zone will be a minimum of 25 feet in all directions around the drill rig. Other work areas will be delineated as controlled access work areas or general construction areas to maintain safe working conditions for personnel and visitors. The Site Health and Safety Officer has at his/her discretion the authority to increase the size of the exclusion zone, if necessary, or to establish an exclusion zone for any of the other tasks.

IMPLEMENTATION DOCUMENT
FOR
NORTHWEST BOUNDARY SYSTEM
LONG-TERM IMPROVEMENTS
INTERIM RESPONSE ACTION

VOLUME 2 ENGINEERING SPECIFICATIONS

FINAL

January 1992

Prepared by
Morrison-Knudsen Corporation
Environmental Services Group
Denver, Colorado 80203

Prepared for
Shell Oil Company
Denver, Colorado 80203

LIST OF SPECIFICATIONS

- SPECIFICATION 02702 - ALLUVIAL MONITORING WELLS
- SPECIFICATION 02936 - SOIL PREPARATION, SEEDING, AND MULCHING
- SPECIFICATION 03301 - CAST-IN-PLACE CONCRETE



MORRISON KNUDSEN CORPORATION
ENVIRONMENTAL SERVICES DIVISION

SPEC NO.: 02702
W.O. NO.: 2127-36
DATE: 01/21/92
ISSUE/REV.: 0
PAGE: 1

SPECIFICATION 02702

ALLUVIAL MONITORING WELLS

CLIENT: SHELL OIL COMPANY

PROJECT: ROCKY MOUNTAIN ARSENAL REMEDIATION PROJECT

NORTHWEST BOUNDARY SYSTEM LONG-TERM

IMPROVEMENTS INTERIM RESPONSE ACTION

LOCATION: ROCKY MOUNTAIN ARSENAL, COMMERCE CITY, CO



<u>CONTENTS</u>	<u>PAGE</u>
1. SCOPE	3
2. RELATED WORK	3
3. REFERENCE STANDARDS	3
4. CONTRACTOR QUALIFICATIONS	4
5. ALLUVIAL MONITORING WELL DESCRIPTION	4
6. MATERIALS	4
7. EQUIPMENT	5
8. WELL CONSTRUCTION	5
9. WELL DEVELOPMENT	7
10. CLEANUP	7
11. QUALITY CONTROL	7



4. CONTRACTOR QUALIFICATIONS

- A. The Contractor shall submit evidence to the Engineer, including drilling experience in the Denver area and a list of available drilling and support equipment, that they are competent to construct a monitoring well of the design provided by the Engineer. This evidence should ensure that the Contractor will have sufficient experienced personnel to construct the monitoring wells. The Contractor shall supervise the well construction including borehole drilling, well construction, and well development.

5. ALLUVIAL MONITORING WELL DESCRIPTION

- A. The monitoring wells shall be constructed within a borehole of the diameter shown on the Drawings to total depth. The well shall be completed with PVC slotted and blank casing, bottom cap or plug, top cap, well pack, bentonite seal, cement/bentonite grout seal, and a lockable well cover on a steel protective casing set in a reinforced concrete well pad.

6. MATERIALS

- A. Blank Casing: Blank casing shall be new, flush-threaded (ASTM F480 threads) PVC pipe of the dimensions shown on the Drawings with a vented, PVC top cap. Blank casing shall either be certified clean from the manufacturer and received in sealed bags, or steam cleaned prior to use.
- B. Well Screen: The well shall be completed with new, flush-threaded (ASTM F480 threads) commercially slotted PVC casing; and a solid, one-piece, flush-threaded PVC bottom cap or plug. Slot size and well screen dimensions are shown on the Drawings. Well screen shall either be certified clean from the manufacturer and received in sealed bags, or steam cleaned prior to use.
- C. Well Pack: The well pack shall consist of washed silica sand as produced by Colorado Silica Sand or approved equal of the graded size shown in the Drawings. Well pack characteristics may be changed by the Engineer dependent upon subsurface geologic conditions encountered during borehole drilling.



- D. Bentonite: Bentonite used shall be sodium cation base montmorillonite, premium grade Wyoming-type bentonite, which conforms to the most recent applicable API specifications. The Contractor shall submit a certificate of compliance. Bentonite shall be protected from moisture during transit and storage.
- E. Water: A source of potable water for use during drilling operations will be identified by the Engineer. The Contractor is responsible for transporting water to each well site.
- F. Protective Casing and Cover: A carbon steel pipe of the dimensions shown in the Drawings shall be used for the surface protective casing. The steel casing shall have a metal, lockable cover (MAASS or approved equal).
- G. Cement: Type I, II, or I-II Portland cement shall be used for applications requiring cement.

7. EQUIPMENT

- A. Drilling of the alluvial wells shall be accomplished by use of a suitable hollow-stem auger or other well drilling rig not requiring drilling fluid for operation. The drilling rig shall have the capabilities of successfully drilling and completing wells of the type and size shown in the Drawings to a depth of at least 90 ft. The Contractor shall have the capability of installing the required PVC casing string, well pack, bentonite seal, cement/bentonite grout, protective casing, and concrete well pad.

8. WELL CONSTRUCTION

- A. General: Alluvial monitoring wells shall be completed approximately as discussed in the following sections. Site-specific geologic conditions may require changes to well construction plans. Modifications to construction specifications must be approved in advance in writing by the Engineer. Each activity must be completed to the satisfaction of the Engineer.
- B. Borehole: A borehole of the diameter shown in the Drawings shall be drilled to penetrate approximately 1 ft into the Denver Formation. Sufficient depth into the Denver Formation will be verified by the Engineer.



Sediment samples shall be collected at the discretion of the Engineer.

- C. Well String: The well string, including the well screen, blank casing, bottom cap or plug and top cap shall be constructed to the dimensions shown on the Drawings.
- D. Well Pack: A well pack of washed silica sand shall be placed from the total depth of the borehole to the depth above the well screen specified in the Drawings. The well pack shall fill the annulus between the well string and the borehole wall.
- E. Annular Seal: A hydrated bentonite seal of the dimensions shown in the Drawings shall be placed on top of the well pack. A cement/bentonite grout shall be placed from the bentonite seal to the level shown in the Drawings. In uncased boreholes drilled to total depth, well construction operations shall be conducted continuously from the beginning of well pack placement until the cement/bentonite grout is placed. Additional cement/bentonite grout will be added as necessary to maintain the grout level at the desired level. The grout shall be machine mixed to the satisfaction of the Engineer and shall consist of 20 parts cement to 1 part bentonite with a maximum of 6.5 gallons of water added per sack of cement.
- F. Surface Completion: The surface completion, including protective casing, well pad, and final surface grading shall be as shown on the Drawings. The protective casing shall be placed in a boring that is at least 8 inches in diameter.
- G. Well Drill Cuttings: Well cuttings produced from the saturated zone during drilling operations shall be considered potentially contaminated. These cuttings shall be secured in 55-gallon steel drums provided by and disposed of by the Engineer.
- H. Surveying: The elevation and location coordinates of the northernmost point on the top of the PVC casing on the alluvial monitoring wells will be surveyed by the Engineer.



9. WELL DEVELOPMENT

- A. The wells shall be developed by the Contractor following completion of well construction activities. Well development shall be conducted by alternately surging, and bailing or pumping each well as directed by the Engineer, and shall include surging of all screened sections of the aquifer. Surging shall be performed by use of a surge block or bailer having an outside diameter no more than 1 inch smaller nor more than 25 percent smaller than the inside diameter of the well screen. Wells shall be developed for a minimum of two hours, or until water discharged during surging of all screened well sections is essentially free of sand, whichever is greater. Water removed from a well during development shall be visually monitored for sand content and turbidity. In any case, a minimum of five (5) times the estimated water contained within the borehole (assuming a porosity of the well pack of 0.3) shall be bailed and/or pumped from each well during well development. The total volume of water removed during well development shall be recorded by the Engineer. The Contractor shall place water generated during well development activities into suitable drums or tanks provided and disposed of by the Engineer.

10. CLEANUP

- A. At completion and before acceptance of this work, all equipment, surplus materials and rubbish shall be removed, leaving the site in a neat, presentable condition acceptable to the Engineer. The Contractor shall take precautions to prevent fuel or lubricant spills on the ground surface; and shall be responsible for remediating to the satisfaction of the Engineer any spills that do occur.

11. QUALITY CONTROL

- A. General: The Contractor shall maintain records as required by the Engineer to assure that well construction is being conducted within contract limits. The results of drilling, well construction, and well development activities shall be documented to assure they meet specifications. The Contractor shall maintain records of observations, measurements and tests performed. These records shall be furnished to



the Engineer no later than 24 hours after the tests, measurements, and/or observations are made.

- B. Well Construction Log: The Contractor and Engineer shall each maintain logs of daily activities. A well construction log shall be maintained by both the Engineer and Contractor which shall document material quantities and placement depths for well construction and depths to the water table and Denver Formation. The Engineer will also provide a geologic log for each borehole drilled.



MORRISON KNUDSEN CORPORATION
ENVIRONMENTAL SERVICES DIVISION

SPEC NO.: 02936
W.O. NO.: 2127-36
DATE: 02/21/92
ISSUE/REV.: 0
PAGE: 1

SPECIFICATION 02936

SOIL PREPARATION, SEEDING, AND MULCHING

CLIENT: SHELL OIL COMPANY

PROJECT: ROCKY MOUNTAIN ARSENAL REMEDIATION PROJECT

NORTHWEST BOUNDARY SYSTEM LONG-TERM

IMPROVEMENTS INTERIM RESPONSE ACTION

LOCATION: ROCKY MOUNTAIN ARSENAL, COMMERCE CITY, CO



	<u>CONTENTS</u>	<u>PAGE</u>
1.	SCOPE	3
2.	RELATED WORK	3
3.	REFERENCE STANDARDS	3
4.	CONTRACTOR QUALIFICATIONS	3
5.	GENERAL PROCEDURES	4

SPECIFICATION 02936

SOIL PREPARATION, SEEDING, AND MULCHING

1. SCOPE

A. This specification and other Contract Documents cover the establishment and maintenance of vegetation over the final graded surface. The Contractor shall furnish materials, equipment, and labor to complete preparation of the seedbed, seeding, and establishment of erosion protection in areas where new monitoring wells are constructed.

B. Certificate of Compliance: The Contractor shall provide written certification that the labor, equipment and materials defined in this specification and on the Drawings have been completed in compliance with said specifications. This certification shall be provided to the Engineer upon completion of the work and prior to acceptance.

2. RELATED WORK

A. The following related work is covered in other specifications:

1) Alluvial Monitoring Wells (Specification 02702)

3. REFERENCE STANDARDS

A. Any reference to standards of any society, institute, association or governmental agency shall be the edition in effect as of the date of this specification, unless stated otherwise.

4. CONTRACTOR QUALIFICATIONS

A. The Contractor shall submit evidence to the Engineer including a summary of relevant experience, that they are competent to complete seedbed preparation, fertilization, seeding, and establishment of erosion protection. The Contractor shall supervise the work specified herein. The work described above shall be completed to the satisfaction of the Engineer, who will determine the quality of work.



5. GENERAL REQUIREMENTS

A. Seedbed Preparation

- 1) Chiseling: Chisel to a depth of 10-12 inches. The Engineer will approve the type of equipment used.
- 2) Disking: Disk soil to a depth of 6-8 inches to loosen and aerate soil. The Engineer will approve the type of equipment used and whether one or two passes over the ground surface will be required, depending upon the type of equipment used and the topsoil compaction resulting from final site grading.
- 3) Soil Amendments/Fertilizer: Following completion of disking, apply amendments to the soil at the following rates:
 - a) Nitrogen - 35 lbs/acre
 - b) Phosphorus - 35 lbs/acre
 - c) Incorporate commercial fertilizer into the upper 2-3 inches of soil using a spiked-tooth harrow. The commercial brand and rate of application of the fertilizer shall be approved in advance by the Engineer.

The Engineer will approve the type of equipment and method to be used for applying and mixing in amendments.

B. Seeding

1) Seed Mixes

Mix #1:

Seed mix for surface disturbances which will not receive maintenance (mowing).

<u>Scientific Name</u>	<u>Common Name</u>	<u>Variety</u>	<u>Lbs. PLS/ Acre</u>
<u>Bouteloua gracilis</u>	Blue Grama	Hachita	0.8
<u>Pascopyron smithii</u>	Western Wheatgrass	Arriba	4.0
<u>Buchloe dactyloides</u>	Buffaloe Grass	Sharp's	11.7
<u>Sporobolus cryptandrus</u>	Sand Dropseed		<u>0.08</u>
		Total	16.58



Plus 0.01 PLS of each of the following:

<u>Erysimum asperum</u>	Wallflower
<u>Gaillardia aristata</u>	Blanket Flower
<u>Linum lewisii</u>	Blue Fax
<u>Helianthus annuus</u>	Annual Sunflower
<u>Achillea lanulosa</u>	Yarrow

Mix #2:

Areas to be maintained by mowing:

<u>Scientific Name</u>	<u>Common Name</u>	<u>Variety</u>	<u>Lbs. PLS/ Acre</u>
<u>Bouteloua gracilis</u>	Blue Grama	Hachita	2.0
<u>Buchloe dactyloides</u>	Buffaloe Grass	Sharp's	<u>10.0</u>
		Total	12.0

- 2) Application Rate: (Refer to Species List)
Dependent on area to be seeded.
- 3) Seeding Depth: 1/4 - 1/2 inch
- 4) Schedule: Seed shall be applied as soon after construction as soil conditions will allow.

The equipment and method used to seed will be approved by the Engineer.

C. Erosion Protection

Mulching: Following seeding, complete mulching to minimize the potential for soil erosion. Mulch shall be free of mold, mildew, and weed seeds; and will be inspected for approval by the Engineer prior to application.

- 1) Mulch Type - Grass Hay
- 2) Application Rate - 2 tons/acre



- 3) Stem Length - Minimum of 4-6 inches (prior to crimping)
 - 4) Following application, mulch shall be crimped into the soil. The equipment used will be approved by Engineer.
- D. Some hand work may be necessary in close proximity to wells and other surface structures. This work would be conducted at the direction of the Engineer.



MORRISON KNUDSEN CORPORATION
ENVIRONMENTAL SERVICES DIVISION

SPEC NO.: 03301
W.O. NO.: 2127-36
DATE: 01/21/92
ISSUE/REV.: 0
PAGE: 1

SPECIFICATION 03301

CAST-IN-PLACE CONCRETE

CLIENT: SHELL OIL COMPANY

PROJECT: ROCKY MOUNTAIN ARSENAL REMEDIATION PROJECT

NORTHWEST BOUNDARY SYSTEM LONG-TERM

IMPROVEMENTS INTERIM RESPONSE ACTION

LOCATION: ROCKY MOUNTAIN ARSENAL, COMMERCE CITY, CO



	<u>CONTENTS</u>	<u>PAGE</u>
1.	SCOPE	3
2.	RELATED WORK	3
3.	REFERENCE STANDARDS	3
4.	CONTRACTOR QUALIFICATIONS	4
5.	GENERAL REQUIREMENTS	4
6.	FORMWORK	4
7.	FINISH	4
8.	CURING	4



SPECIFICATION 03301

CAST-IN-PLACE CONCRETE

1. SCOPE

- A. This specification and other Contract Documents cover the placement of cast-in-place concrete for aprons at new monitoring wells added to the Northwest Boundary System monitoring network. Design details are presented on the Drawings.
- B. Certificate of Compliance: The Contractor shall provide written certification that the labor, equipment and materials defined in this specification and on the Drawings have been completed in compliance with said specifications. This certification shall be provided to the Engineer upon completion of the work and prior to acceptance.

2. RELATED WORK

- A. The following related work is covered in other specifications:
- 1) Alluvial Monitoring Wells (Specification 02702)

3. REFERENCE STANDARDS

- A. Organizations whose standards are referenced herein include the following:
- 1) American Concrete Institute (ACI)
 - 2) American Society for Testing and Materials (ASTM)
- B. For standards referred to in ACI 301, the edition and supplements in use and currently available at date of this specification shall apply.



4. CONTRACTOR QUALIFICATIONS

The Contractor shall submit evidence to the Engineer, including a summary of relevant experience, that they are competent to complete concrete work as described in this specification and shown on the Drawings.

5. GENERAL REQUIREMENTS

- A. Shop Drawings: None are required and none will be furnished. Cast-in-place concrete shall be located and sized as required by the design drawings.
- B. Earth Compaction: The earth upon which each of the well aprons will bear, shall be undisturbed soil.

MATERIALS

- A. Concrete: 3,000 psi or commercial dry mix for pouring small quantities.
- B. Portland Cement: ASTM C150, Type I, II, or I-II.
- C. Sand: ASTM C144, washed natural sand, free from impurities.
- D. Aggregate: Washed natural aggregate maximum 1/2 inch size, free from impurities.
- E. Water: Free of deleterious amount of acids, alkalis, and organic materials.
- F. Forms: Wood, steel, or other Engineer approved material.

6. FORMWORK

Prior to concrete placement, forms shall be approved by the Engineer for compliance with the plans and specifications.

7. FINISH

Trowel finish the concrete aprons at wells.

8. CURING

Requirements for curing and protection shall be as specified in ACI 301.

IMPLEMENTATION DOCUMENT
FOR
NORTHWEST BOUNDARY SYSTEM
LONG-TERM IMPROVEMENTS
INTERIM RESPONSE ACTION

VOLUME 3 ENGINEERING DRAWINGS

FINAL

January 1992

Prepared by
Morrison-Knudsen Corporation
Environmental Services Group
Denver, Colorado 80203

Prepared for
Shell Oil Company
Denver, Colorado 80203

MORRISON KNUDSEN CORPORATION

INDEX TO DRAWINGS

DRAWING NO.	DRAWING TITLE
72-0-001	GENERAL LAYOUT/TITLE DRAWING
72-1-001	WATER TABLE CONFIGURATION
72-1-002	DISTRIBUTION OF GROUNDWATER CONTAMINATION
72-2-001	WATER TABLE/AQUIFER WATER QUALITY MONITORING NETWORKS
72-2-002	TREATMENT PLANT MONITORING NETWORK
72-2-003	MONITORING WELL DETAIL

NORTHWEST BOUNDARY SYSTEM LONG-TERM IMPROVEMENTS INTERIM RESPONSE ACTION

ROCKY MOUNTAIN ARSENAL - ADAMS COUNTY, COLORADO

ROCKY MOUNTAIN ARSENAL - ADAMS COUNTY, COLORADO

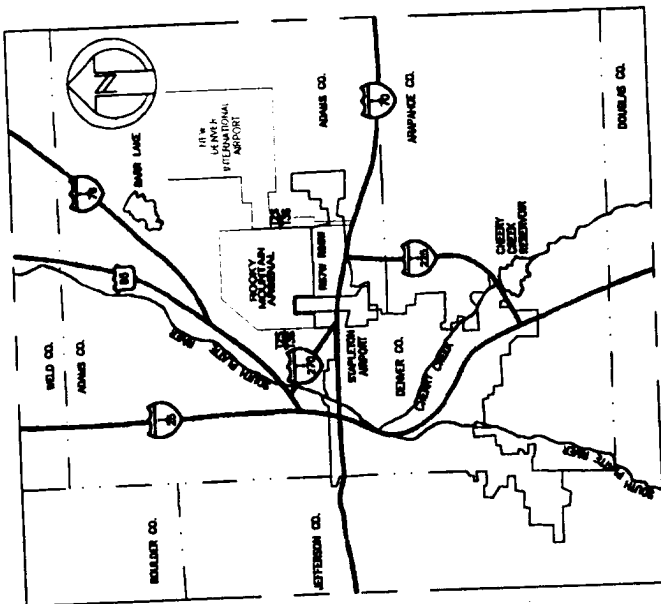

LOCATION MAP

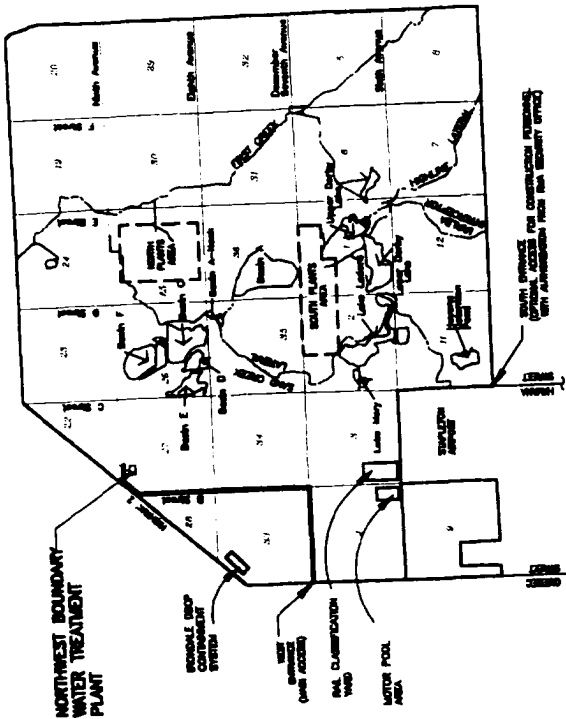

CONTRACTOR ACCESS

MORRISON KNUDSEN CORPORATION
ENVIRONMENTAL SERVICES GROUP

SHELL OIL COMPANY
 NORTHWEST BOUNDARY SYSTEM
 LONG-TERM IMPROVEMENTS IRA
 GENERAL LAYOUT/
 TITLE DRAWING

DRAWN BY RLS	CHECKED BY MFW	WORK ORDER NUMBER 2127
DEVELOPED BY RLS	SCALE NONE	DRAWING NUMBER 72-0-001
APPROVED BY TRK		REV 0

REV	DATE	DESCRIPTION	BY	SR ENGR	DEPT MGR	PE	CAUD FILE NAME	CAUD PLOT DATE
0	01/21/92	ISSUED FOR IMPLEMENTATION	RLS	/	TRK	MFW	36C00010.DWG	01/14/92
A	11/15/91	ISSUED FOR REVIEW AND COMMENT	RLS	/	TRK	MFW		

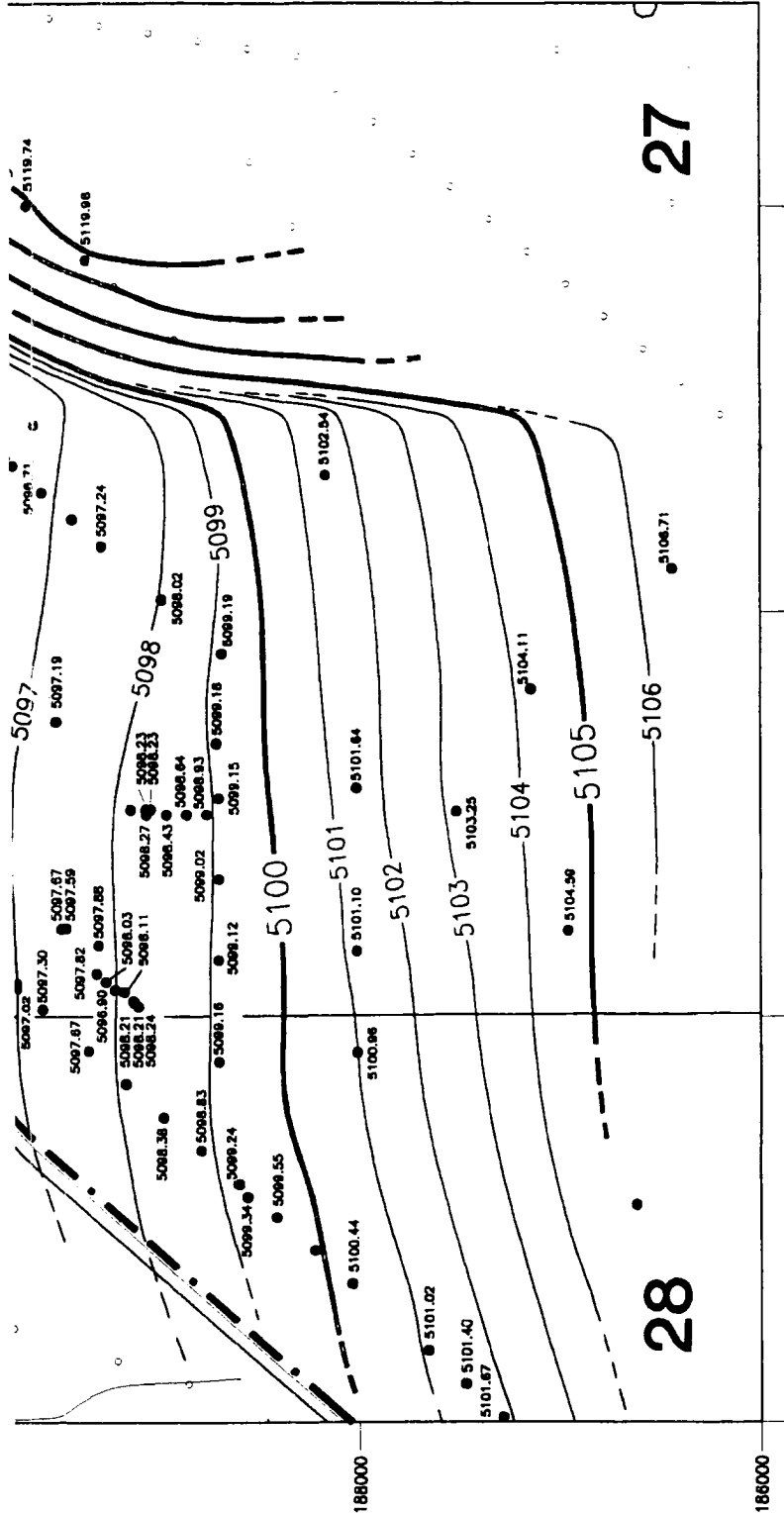

LEGEND

- ROAD
 - RMA BOUNDARY
 - - - SECTION BOUNDARY
 - SLURRY WALL
 - - - STREAM OR CANAL
 - WELL
 - MEASURED WELL
 - 5104.59 MEASURED WELL; ANOMALOUS DATA NOT USED IN INTERPRETATION
 - - - 1 FT. CONTOUR (DASHED WHERE INFERRED)
 - - - 5 FT. CONTOUR (DASHED WHERE INFERRED)
- WATER LEVELS MEASURED AUGUST 1 AND 2, 1991

MORRISON KNUDSEN CORPORATION
ENVIRONMENTAL SERVICES GROUP

REV	DATE	DESCRIPTION	BY	SR ENGR	DEPT MGR	PE	CADD FILE NAME	CADD PLOT DATE	APPROVED BY	DRAWING NUMBER	REV
0	01/21/92	ISSUED FOR IMPLEMENTATION	RLS	TRK	MFV		SHELL OIL COMPANY NORTHWEST BOUNDARY SYSTEM LONG-TERM IMPROVEMENTS IRA	01/14/92	TRK	2127	0
A	11/15/91	ISSUED FOR REVIEW AND COMMENT	RLS	TRK	/	/	WATER TABLE CONFIGURATION		RJC	72-1-001	
									TRK		
									APPROVED BY	WORK ORDER NUMBER	
									TRK	2127	

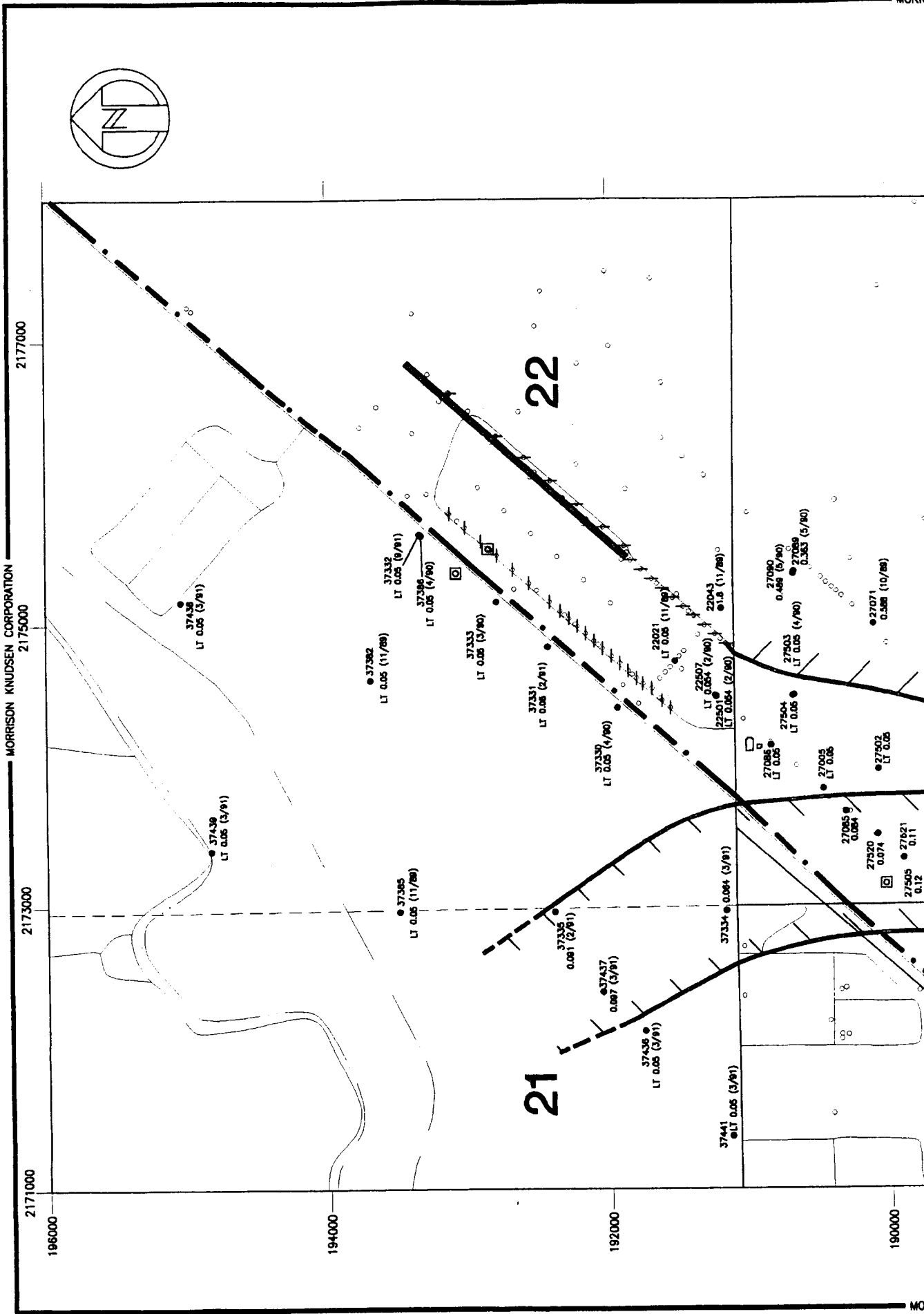

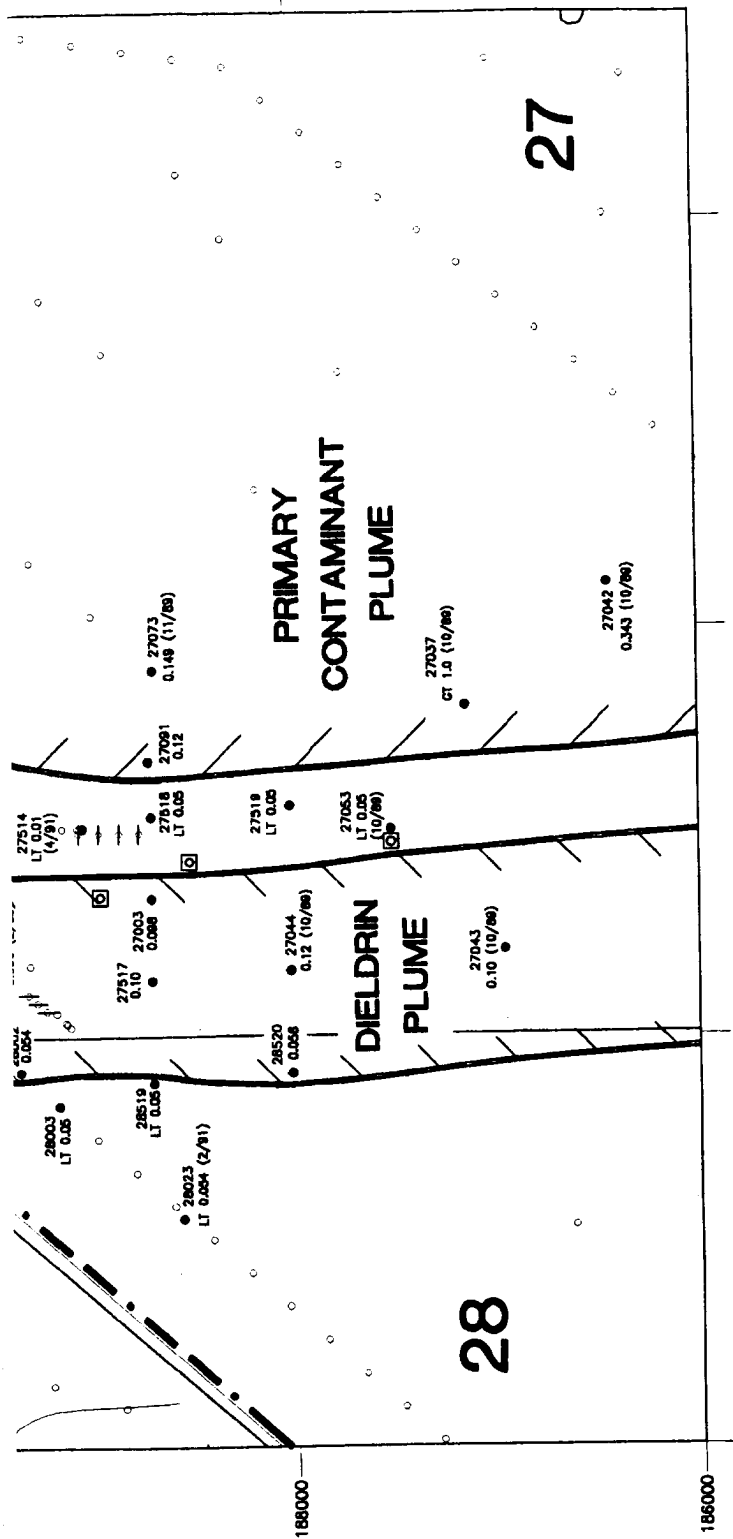

LEGEND

- ROAD
- RMA BOUNDARY
- - - SECTION BOUNDARY
- SLURRY WALL
- - - STREAM OR CANAL
- MONITORING WELL
- ⊕ EXTRACTION WELL
- ⊖ RECHARGE WELL
- NEW WELL

DIELDRIN PLUME CONCENTRATIONS IN GROUNDWATER ABOVE CREEK; DASHED WHERE INFERRED
 LT = LESS THAN
 GT = GREATER THAN
 POSTED DIELDRIN CONCENTRATIONS IN ug/L.
 ● SAMPLED MONITORING WELL
 27043 0.12 WELLS SAMPLED AUGUST 1991 UNLESS NOTED OTHERWISE.

		MORRISON KNUDSEN CORPORATION ENVIRONMENTAL SERVICES GROUP	
DRAWN BY RLS	CHECKED BY MFW	WORK ORDER NUMBER 2127	
DEVELOPED BY RJC	SCALE NONE	DRAWING NUMBER 72-1-002	
APPROVED BY TRK		REV 0	
SHELL OIL COMPANY NORTHWEST BOUNDARY SYSTEM LONG-TERM IMPROVEMENTS IRA		DISTRIBUTION OF GROUNDWATER CONTAMINATION	
01/21/92	TRK / MFW	CADD FILE NAME 36W00020.DWG	CADD PLOT DATE 01/14/92
A 11/15/91	RLS / TRK /	SR ENGR	DEPT MGR PE
REV	DATE	DESCRIPTION	BY

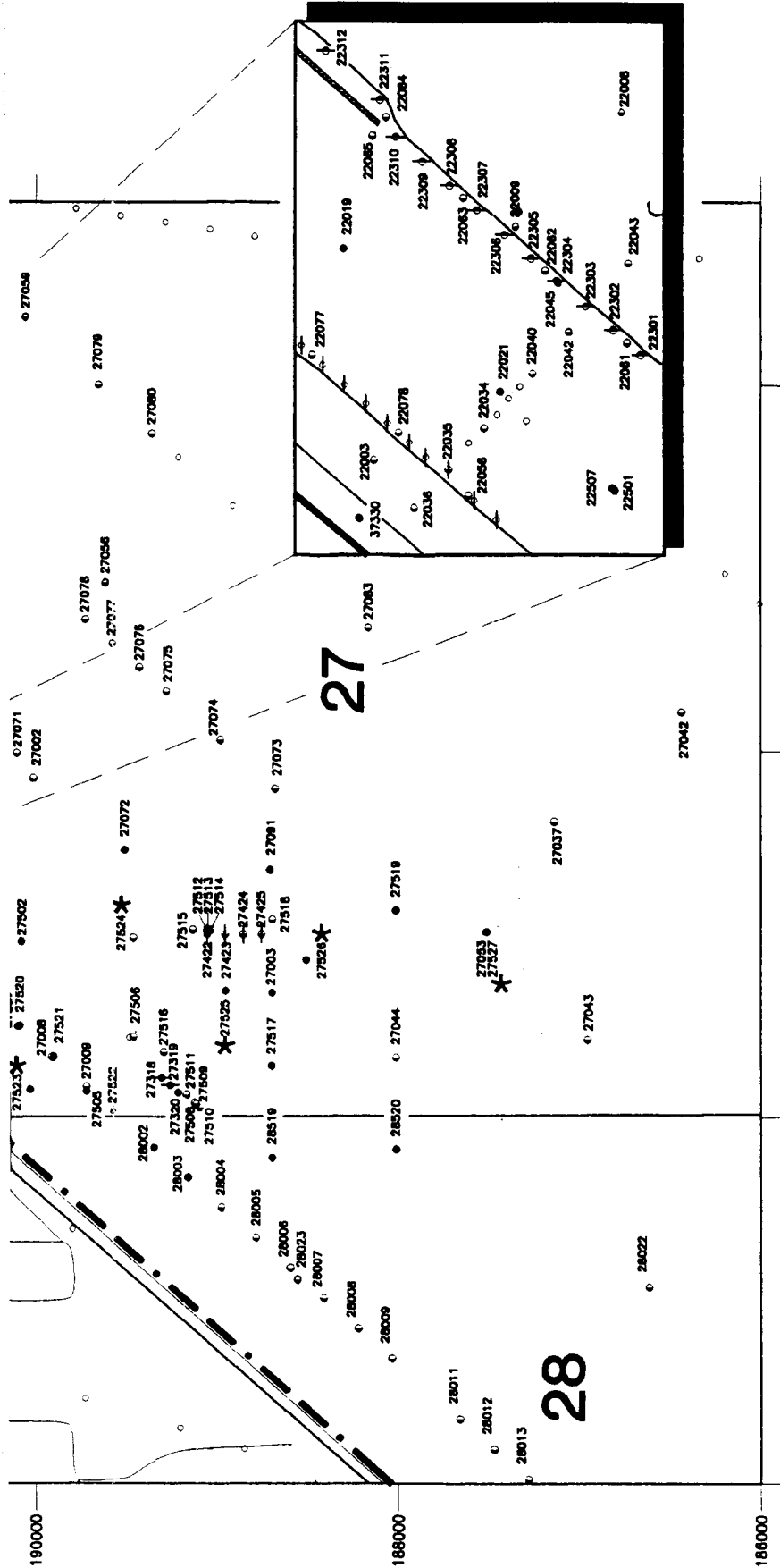

LEGEND

- ROAD
- RMA BOUNDARY
- - - SECTION BOUNDARY
- SLURRY WALL
- - - STREAM OR CANAL
- MONITORING WELL
- ⊕ EXTRACTION WELL
- ⊖ RECHARGE WELL
- WATER QUALITY MONITORING ONLY
- WATER TABLE MONITORING ONLY
- WATER QUALITY AND WATER TABLE MONITORING
- NEW WELL



MORRISON KNUDSEN CORPORATION
ENVIRONMENTAL SERVICES GROUP

REV	DATE	DESCRIPTION	BY	SR ENGR	DEPT MGR	PE	CADD FILE NAME	CADD PLOT DATE
0	01/21/92	ISSUED FOR IMPLEMENTATION	RLS /	TRK	MFV		36W00030.DWG	01/14/92
A	11/15/91	ISSUED FOR REVIEW AND COMMENT	RLS /	TRK	MFV			
REV	DATE	DESCRIPTION	APPROVED BY	SCALE	WORK ORDER NUMBER	DRAWING NUMBER		
			TRK	NONE	2127	72-2-001		

MORRISON KNUDSEN CORPORATION

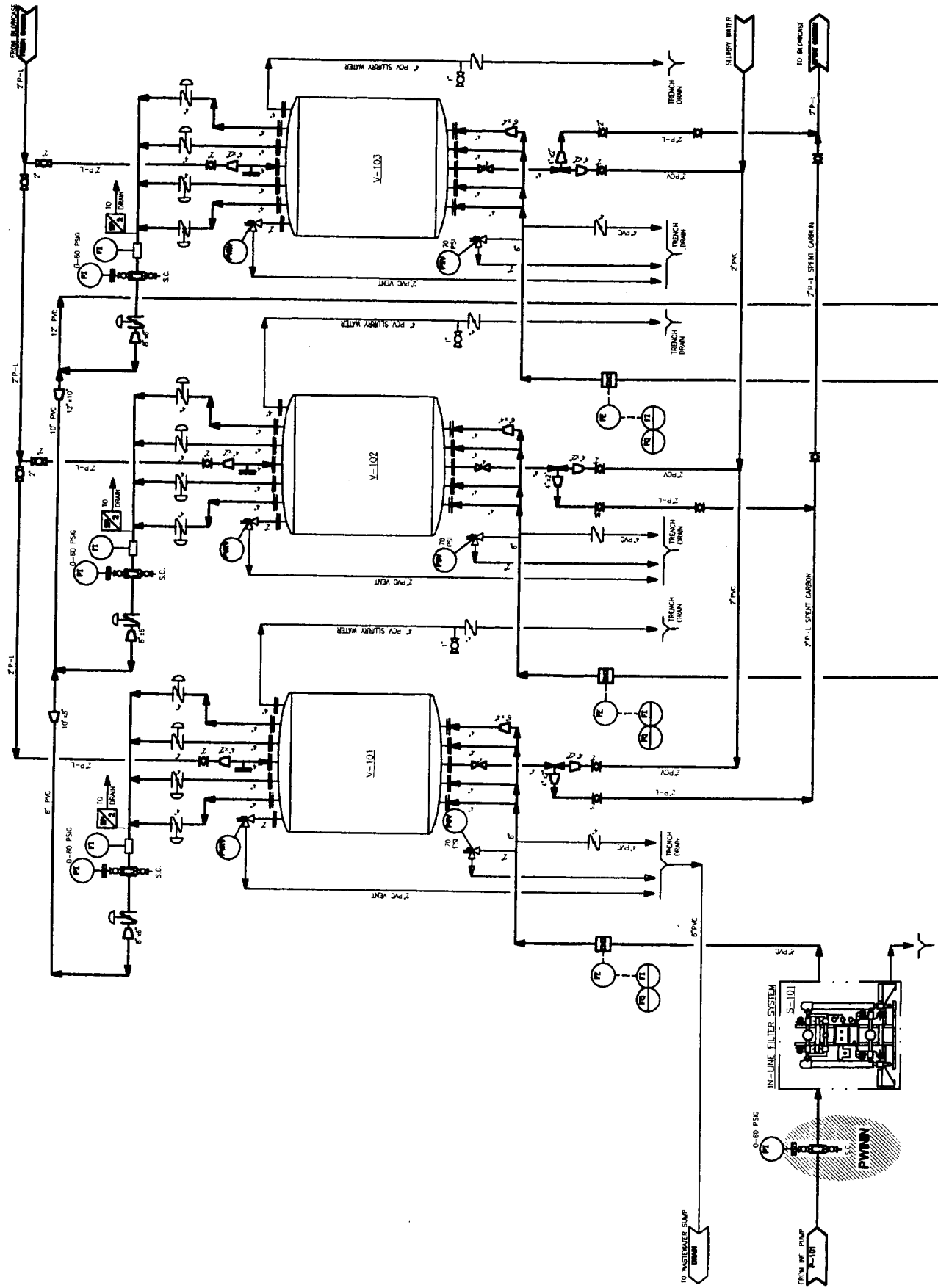

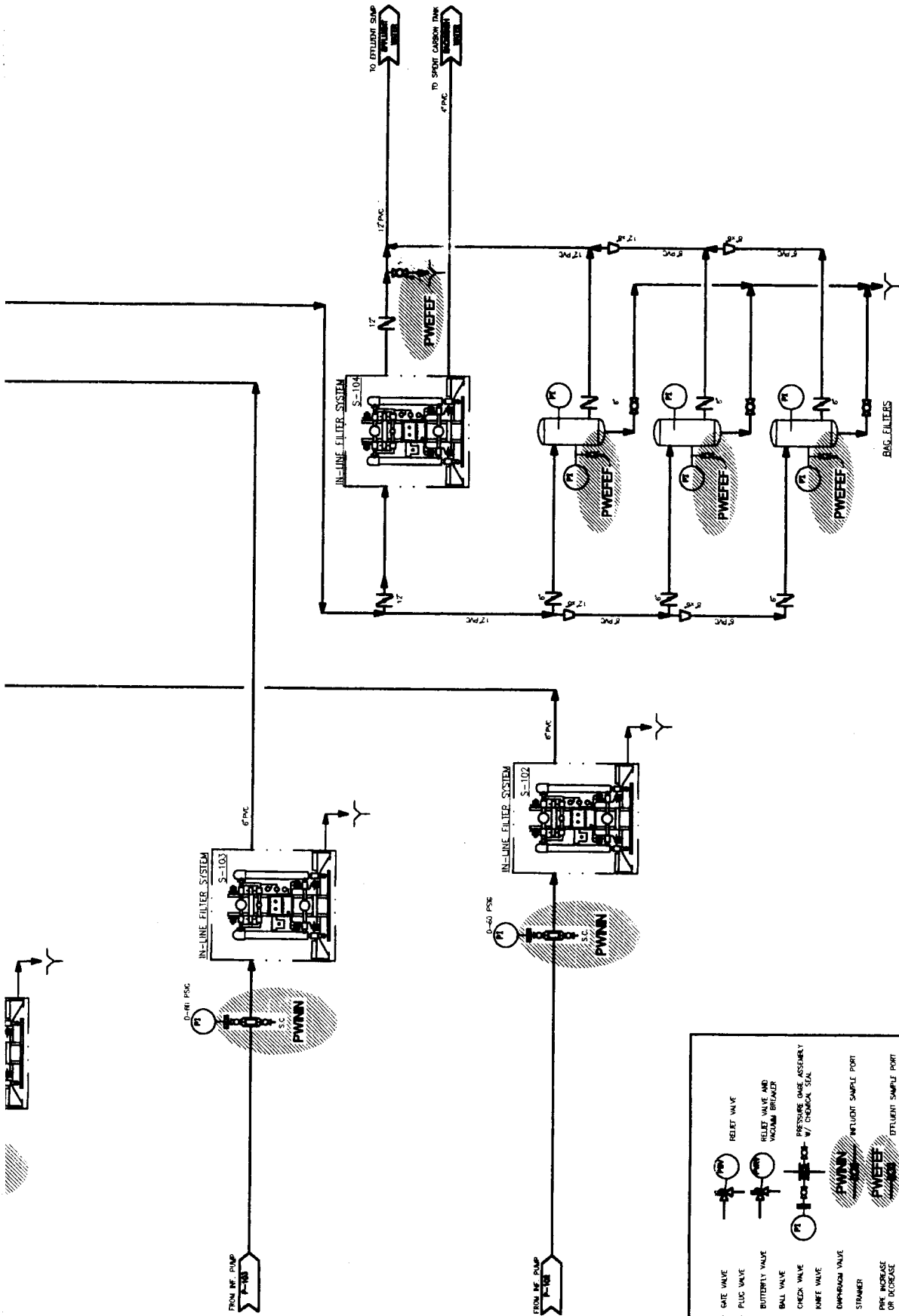

LEGEND

	GATE VALVE		RELIEF VALVE
	PLUG VALVE		RELIEF VALVE AND VACUUM BREAKER
	BUTTERFLY VALVE		PRESSURE GAUGE ASSEMBLY
	BALL VALVE		INFLUENT SAMPLE PORT
	CHECK VALVE		EFFLUENT SAMPLE PORT
	KNIFE VALVE		SOUR GAS
	DIAPHRAGM VALVE		P-L POLYPROPYLENE LINED STEEL
	STEAMER		P-C POLYVINYL CHLORIDE
	FLOW INCREASE OR DECREASE		C-S CARBON STEEL
	REDUCING OR INCREASING VALVE (EXTERNALLY CONTROLLED)		H-C HAZARDOUS CONNECTION
	SHOCK PROHIBITOR		S-S TYPE 316 STAINLESS STEEL
	ANTI-SIPHON VALVE		

MORRISON KNUDSEN CORPORATION ENVIRONMENTAL SERVICES GROUP		SHELL OIL COMPANY NORTHWEST BOUNDARY SYSTEM LONG-TERM IMPROVEMENTS IRA	
ISSUED FOR IMPLEMENTATION	01/21/92	TRK	TRK
ISSUED FOR REVIEW AND COMMENT	11/15/91	TRK	TRK
DESCRIPTION		SR ENGR	DEPT MGR
BY		PE	
DATE			
REV			
0	01/21/92	TRK	TRK
A	11/15/91	TRK	TRK
REV	DATE	BY	DEPT MGR
0	01/14/92	TRK	PE
72-2-002	DRAWING NUMBER	36D00010.DWG	CADD FILE NAME
2127	WORK ORDER NUMBER		
NONE	SCALE		
AML	DEVELOPED BY		
TRK	APPROVED BY		
MFW	CHECKED BY		

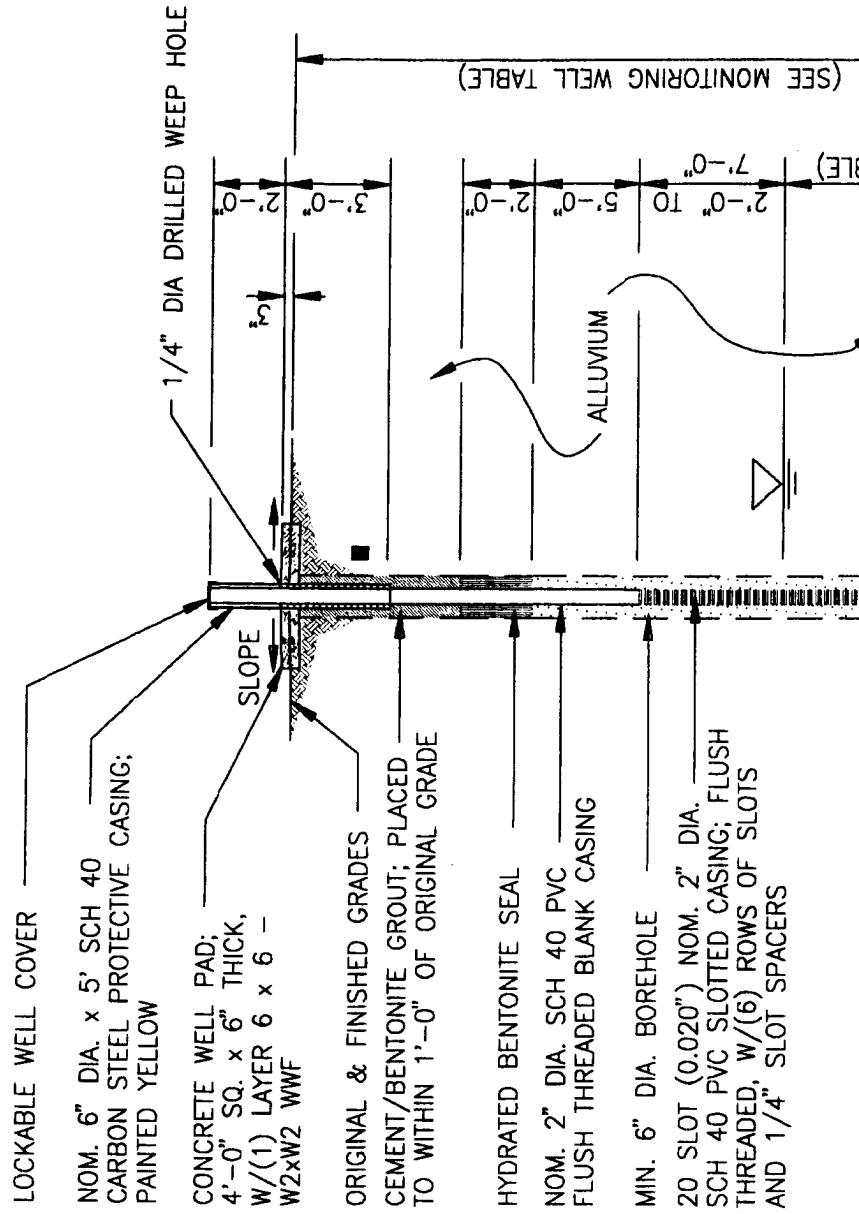

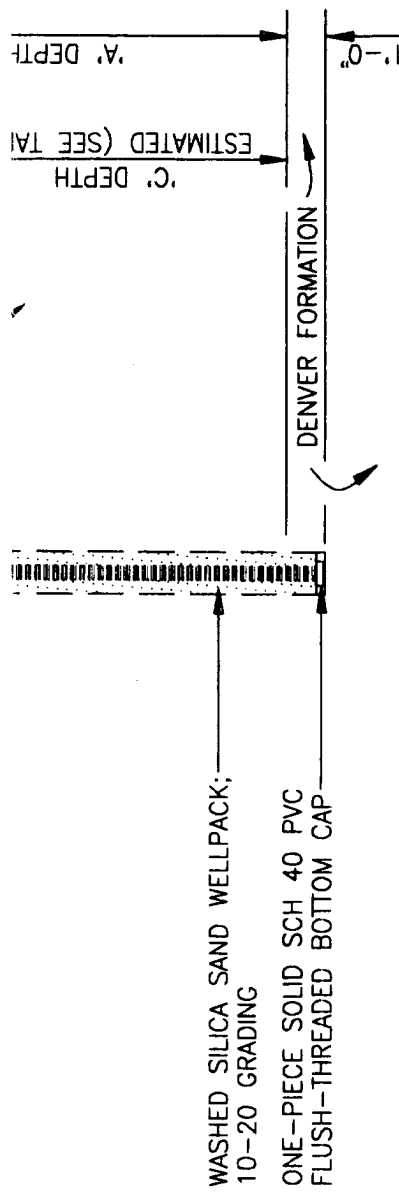

TYPICAL ALLUVIAL MONITORING WELL
NO SCALE

ALLUVIAL MONITORING WELLS

WELL	COORDINATES		APPROX. DEPTHS (FT)	
	N	E	'A'	'C'
22511	192845.00	2175540.00	46	13
37600	193065.00	2175395.00	44.5	13
27523	190030.00	2173150.00	49	17.5
27524	189460.00	2173980.00	58	28
27525	188950.00	2173690.00	58	25.5
27526	188510.00	2173860.00	59	18.5
27527	187510.00	2173950.00	65	14.5

MORRISON KNUDSEN CORPORATION ENVIRONMENTAL SERVICES GROUP		CHECKED BY MFW		WORK ORDER NUMBER 2127	
DRAWN BY RLS		DEVELOPED BY SCALE NONE		DRAWING NUMBER 72-2-003	
APPROVED BY TRK		REV 0			
SHELL OIL COMPANY NORTHWEST BOUNDARY SYSTEM LONG-TERM IMPROVEMENTS IRA		MONITORING WELL DETAIL		CADD FILE NAME 36W00040.DWG	
CADD PLOT DATE 01/14/92		SR ENGR MGR PE			
ISSUED FOR IMPLEMENTATION		RLS / TRK MFW			
ISSUED FOR REVIEW AND COMMENT		RLS / TRK MFW			
DESCRIPTION		BY		DATE	