

PRELIMINARY ENGINEERING DESIGN PACKAGE
FOR THE NORTH BOUNDARY SYSTEM IMPROVEMENTS
INTERIM RESPONSE ACTION

AUGUST 1989

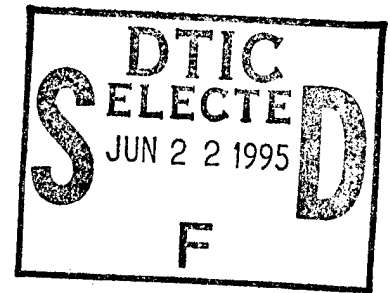

Prepared by
MK-Environmental Services
Denver, Colorado 80203

Prepared for
Shell Oil Company

This document has been approved
for public release and sale; its
distribution is unlimited.

DTIC QUALITY INSPECTED 3

08/14/89

19950620 024

REPORT DOCUMENTATION PAGE

Form Approved
OMB No. 0704-0188

Public reporting burden for this collection of information is estimated to average 1 hour per response, including the time for reviewing instructions, searching existing data sources, gathering and maintaining the data needed, and completing and reviewing the collection of information. Send comments regarding this burden estimate or any other aspect of this collection of information, including suggestions for reducing this burden, to Washington Headquarters Services, Directorate for Information Operations and Reports, 1215 Jefferson Davis Highway, Suite 1204, Arlington, VA 22202-4302, and to the Office of Management and Budget, Paperwork Reduction Project (0704-0188), Washington, DC 20503.

1. AGENCY USE ONLY (Leave blank)	2. REPORT DATE 08/00/89	3. REPORT TYPE AND DATES COVERED	
4. TITLE AND SUBTITLE PRELIMINARY ENGINEERING DESIGN PACKAGE FOR THE NORTH BOUNDARY SYSTEM IMPROVEMENTS INTERIM RESPONSE ACTION		5. FUNDING NUMBERS	
6. AUTHOR(S)			
7. PERFORMING ORGANIZATION NAME(S) AND ADDRESS(ES) MK-ENVIRONMENTAL SERVICES DENVER, CO		8. PERFORMING ORGANIZATION REPORT NUMBER 89262R09	
9. SPONSORING / MONITORING AGENCY NAME(S) AND ADDRESS(ES) SHELL OIL COMPANY DENVER, CO		10. SPONSORING / MONITORING AGENCY REPORT NUMBER	
11. SUPPLEMENTARY NOTES			
12a. DISTRIBUTION / AVAILABILITY STATEMENT APPROVED FOR PUBLIC RELEASE; DISTRIBUTION IS UNLIMITED		12b. DISTRIBUTION CODE	
13. ABSTRACT (Maximum 200 words) THIS INTERIM RESPONSE ACTION CONSISTS OF THE DESIGN AND CONSTRUCTION OF IMPROVEMENTS TO THE NORTH BOUNDARY CONTAINMENT SYSTEM. THE PURPOSE OF THIS DOCUMENT IS TO OUTLINE THE MAIN ELEMENTS DEVELOPED IN THE PRELIMINARY DESIGN PHASE OF THE IRA. THE FOLLOWING ELEMENTS OF THE IRA ARE DISCUSSED: <ol style="list-style-type: none"> 1. RECHARGE TRENCHES 2. WELL CLOSURE 3. DESIGN FLOW RATE 4. EXISTING GROUND WATER TREATMENT PROCESS 5. TREATMENT SYSTEM MODIFICATIONS 6. ADDITIONAL CARBON STORAGE 7. BUILDING MODIFICATIONS 8. TREATMENT PLANT OPERATIONAL IMPROVEMENTS. 			
14. SUBJECT TERMS COST, IRA B, RECHARGE SYSTEM		15. NUMBER OF PAGES	
17. SECURITY CLASSIFICATION OF REPORT UNCLASSIFIED		18. SECURITY CLASSIFICATION OF THIS PAGE	16. PRICE CODE
19. SECURITY CLASSIFICATION OF ABSTRACT	20. LIMITATION OF ABSTRACT		

1.0 INTRODUCTION

The Interim Response Action (IRA) for the North Boundary System Improvements Interim Response Action at the Rocky Mountain Arsenal (RMA) is being conducted as part of the IRA Process for the RMA in accordance with the February 17, 1989 Federal Facility Agreement.

This IRA consists of design and construction of improvements at the North Boundary alluvial groundwater intercept and treatment system at the RMA (see Figure 1). The major features of the North Boundary System, as currently configured, are shown on Figure 2.

The purpose of this document is to outline the main elements developed in the Preliminary Engineering phase of the IRA. Although not specifically required by the IRA Process, it is deemed beneficial to circulate this document so that the Parties and State may provide any comments that could affect the final IRA design.

Accession For	
NTIS CRA&I	<input checked="" type="checkbox"/>
DTIC TAB	<input type="checkbox"/>
Unannounced	<input type="checkbox"/>
Justification	
By	
Distribution /	
Availability Codes	
Dist	Avail and/or Special
A-1	

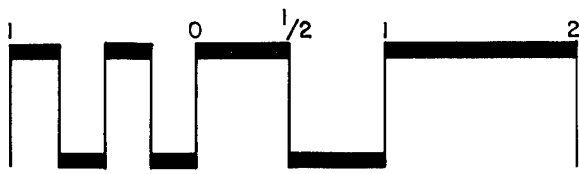
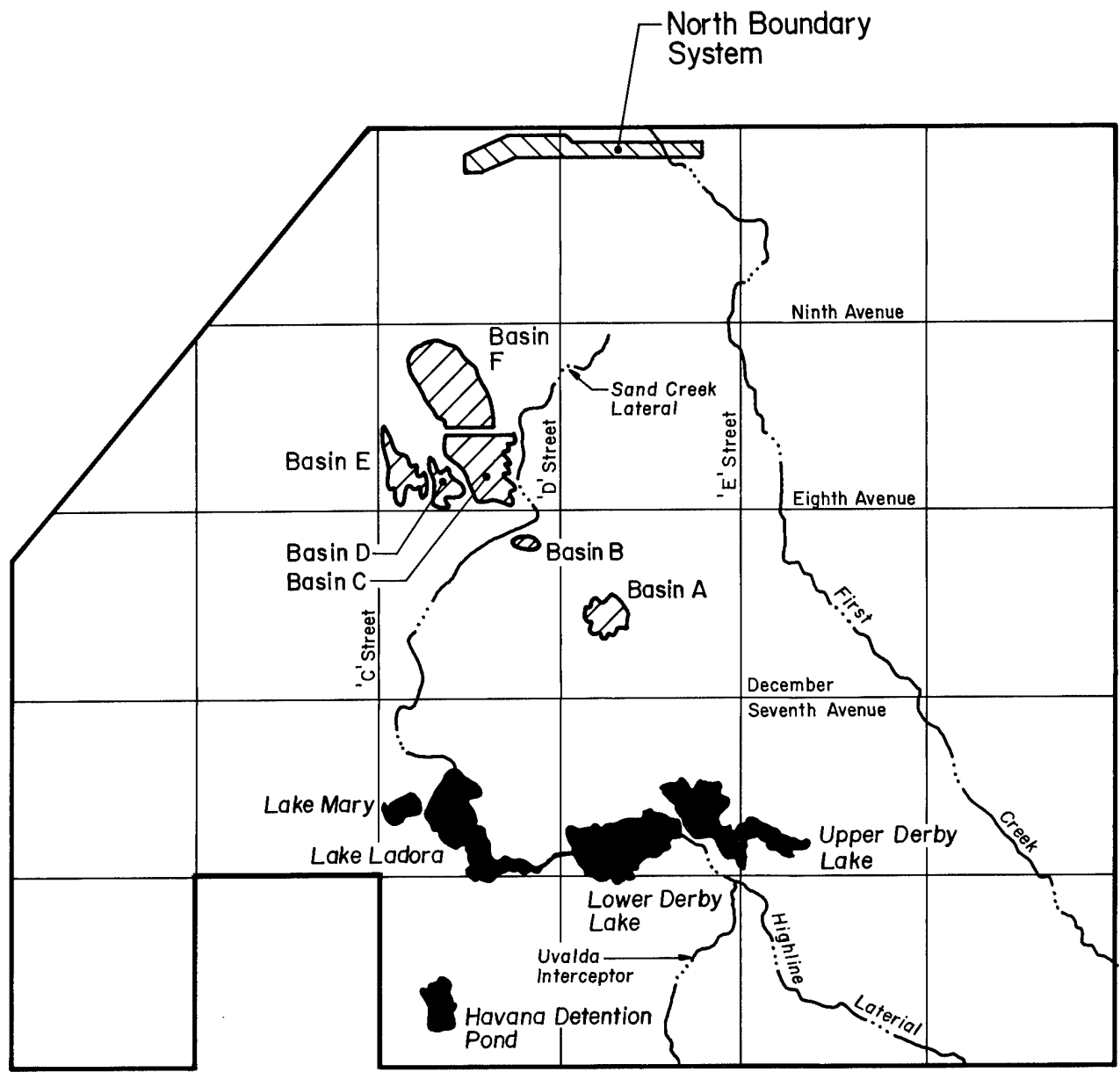

scale in miles

Rocky Mountain Arsenal
Denver, Colorado

North Boundary System Improvements
IRA

Figure 1
Location Map

 **MK-ENVIRONMENTAL SERVICES**
A DIVISION OF MK-FERGUSON

2.0 OVERVIEW OF THE SYSTEM

2.1 EXISTING NORTH BOUNDARY SYSTEM

The existing North Boundary Containment/Treatment System consists of a soil-bentonite barrier, dewatering wells, a treatment plant, and alluvial recharge wells and trenches (see Figure 2). The boundary system is located approximately parallel to and just south of the northern RMA boundary. The soil-bentonite barrier is a 6,470-foot-long, 3-foot-wide, slurry wall keyed over most of its length into the Denver Formation at an average depth of approximately 30 feet. Currently, 35 alluvial dewatering wells are available to pump groundwater from south of the barrier to a groundwater treatment plant. Originally, the dewatering system also included 19 Denver Formation wells. These wells were selected for removal under an IRA for the closure of abandoned wells in accordance with paragraph 22.1(d) of the Federal Facilities Agreement. Removal of these wells is expected to be completed during 1989. The major components of the existing groundwater treatment system include: a raw groundwater collection/pumping system; a pre-filtration system; three 30,000 lb capacity, upflow carbon absorbers; a post-filtration system; and a treated water collection/pumping system. Recharge into the alluvium is possible in 38 alluvial reinjection wells installed along the north side of the soil-bentonite barrier, and 10 recently installed gravel-filled trenches installed along the north side of the western half of the barrier. Because of limited recharge capacity, some treated water is also diverted into the North Bog for recharge into the alluvial aquifer.

2.2 PLANNED IMPROVEMENTS TO THE NORTH BOUNDARY SYSTEM

Subsequent to the publication of the Final Decision Document for this IRA, a preliminary design process has been followed resulting in further definition and refinement of modifications

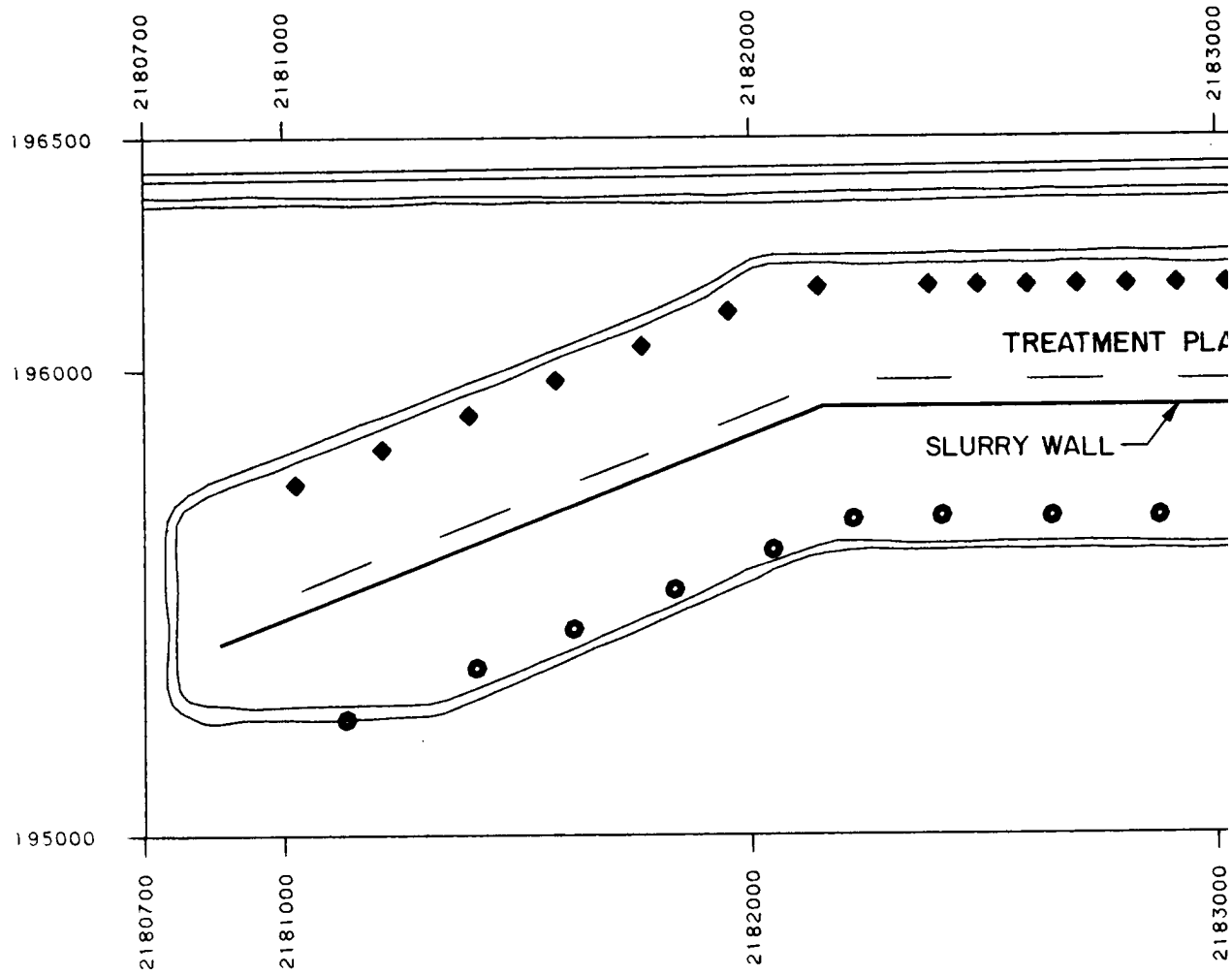

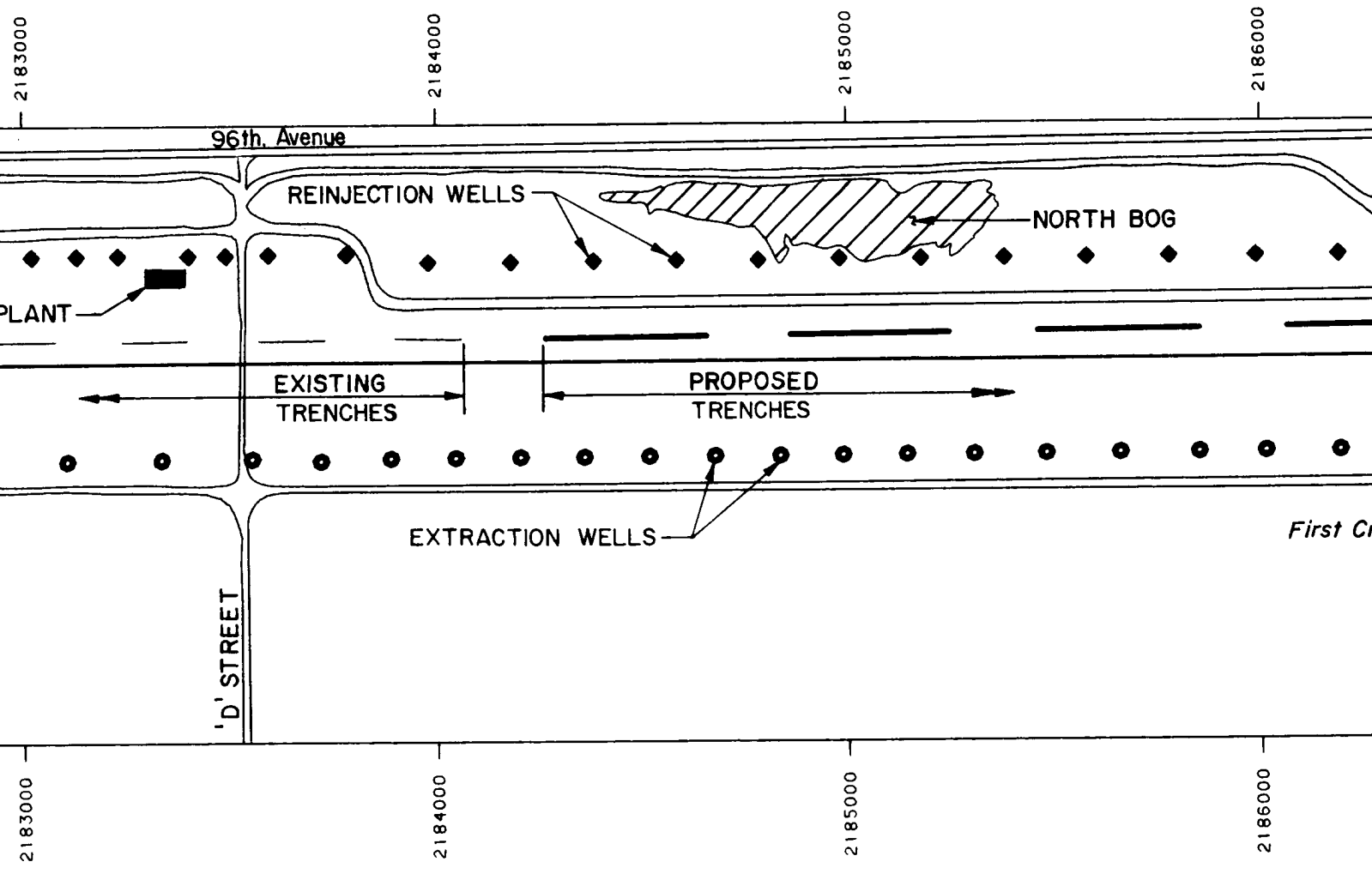

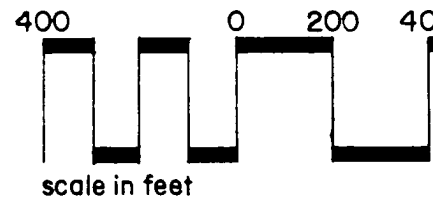
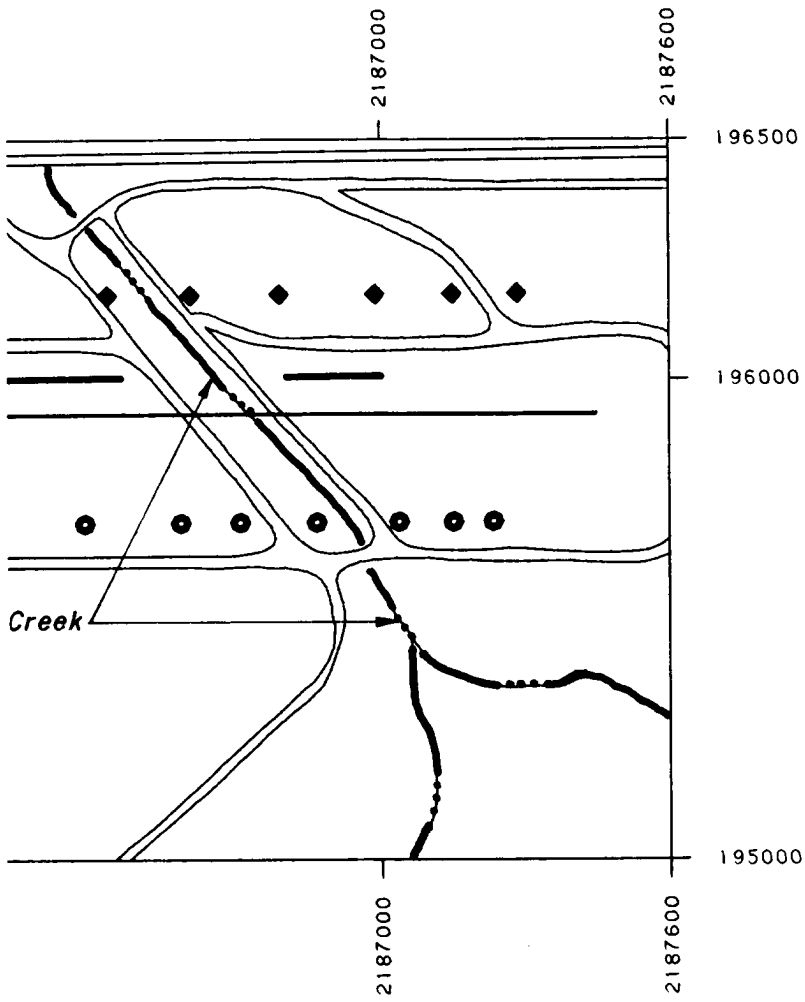

Rocky Mountain
Denver, Color

North Boundary System
IRA

Figure 2
Site Map

 **MK-ENVIRONMENT**
A DIVISION OF MK-FERGUSON

north

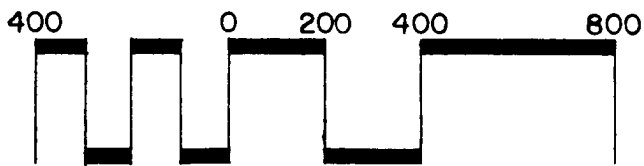

scale in feet

Rocky Mountain Arsenal

Denver, Colorado

North Boundary System Improvements

IRA

Figure 2

Site Map



MK-ENVIRONMENTAL SERVICES
A DIVISION OF MK-FERGUSON

planned under this IRA. The refined modifications have been selected to eliminate bypass of any contaminated alluvial groundwater past the intercept system and to improve the operational characteristics of the treatment plant. The proposed modifications and additions to the system are as follows:

- Construction of a system of alluvial recharge trenches along the eastern half of the system on the north side of the soil-bentonite barrier.
- Modification of the existing treatment plant for improvement of system operation and reliability. The proposed modifications specifically target improved operational flexibility, reduced carbon usage, reduced carbon fines recirculation within the treatment system, and reduced carbon fines introduction to the recharge system.

The Final Decision Document for this IRA also states that any wells that could be acting as contaminant migration pathways from the alluvial aquifer to the Denver Formation would be identified and closed, if not previously closed under the ongoing RMA Abandoned Well Closure IRA. The Abandoned Well Closure IRA appears to have addressed this task adequately based on current information. If during the implementation of the Improvements to the North Boundary System IRA any additional wells are discovered that should be closed, closure will be considered as part of this IRA as discussed in Section 3.3 of this report.

The Final Decision Document also states that additional dewatering wells or interceptor trenches may be installed as part of this IRA. Recent operational changes have been made in the pump and probe settings in an attempt to increase the dewatering capacity of the existing system. Until a full evaluation can be made of the ability of the existing dewatering

system to meet the dewatering requirements, it is deemed inappropriate to install additional dewatering capacity. This evaluation of the adequacy of the dewatering system is currently ongoing. If the need for additional dewatering capacity is demonstrated, such capacity will be added during the detail design phase of this IRA (see Section 3.2).

It should also be pointed out that the alluvial aquifer in which the North Boundary System is constructed is a dynamic system. As upstream recharge sources have changed, and will continue to change, the operation of the North Boundary System must be periodically reevaluated. For example, as the quantity of recharge south of Section 23 has decreased over time (particularly from Basin C), the water levels in Section 23 have declined. In such thin alluvial aquifers, the effectiveness of alluvial wells can vary considerably as the aquifer thickness decreases. For example, a completely adequate dewatering well in 15-foot thick alluvial aquifer may become totally useless when the aquifer thins to five feet. The improvements proposed in this report have been selected as being appropriate for current conditions. However, future changes in the aquifer may require future modifications in either the design of the system or its operation.

3.0 PRELIMINARY DESIGN OF THE NORTH BOUNDARY CONTAINMENT SYSTEM IMPROVEMENTS

3.1 RECHARGE SYSTEM IMPROVEMENTS

Planned improvements to the North Boundary System recharge system consist of construction of a line of recharge trenches extending along the eastern half of the system, located about 45 feet north of the existing soil-bentonite barrier. As shown in Figure 3, the planned trenches include four 400-foot trenches west of First Creek, and one 200-foot trench east of First Creek. These gravel-filled trenches will be constructed to extend, as nearly as practical, to the Denver Formation surface. Recently, new borings were drilled in the vicinity of the new trenches to confirm lithology. Flows into each trench will be metered, with remote readouts being provided in the treatment plant.

Piezometers will be installed in each end of each trench as well as between each set of trenches to allow an accurate determination of the effectiveness of the trenches on the groundwater table near the soil-bentonite slurry wall. The new piezometers located outside the trenches near the slurry wall will be equipped so as to provide remote water level readouts in the treatment plant. The locations of the new borings as well as the proposed locations of the new piezometers are shown in Figure 3.

Consideration is also being given to constructing monitoring wells in the shallow Denver Formation sands. These wells would provide information useful for determining the effect on the shallow Denver Formation caused by modifying alluvial water levels across the slurry wall. Any new Denver Formation wells would be constructed using methods that minimize or eliminate any cross-contamination between the Denver Formation and alluvial aquifers.

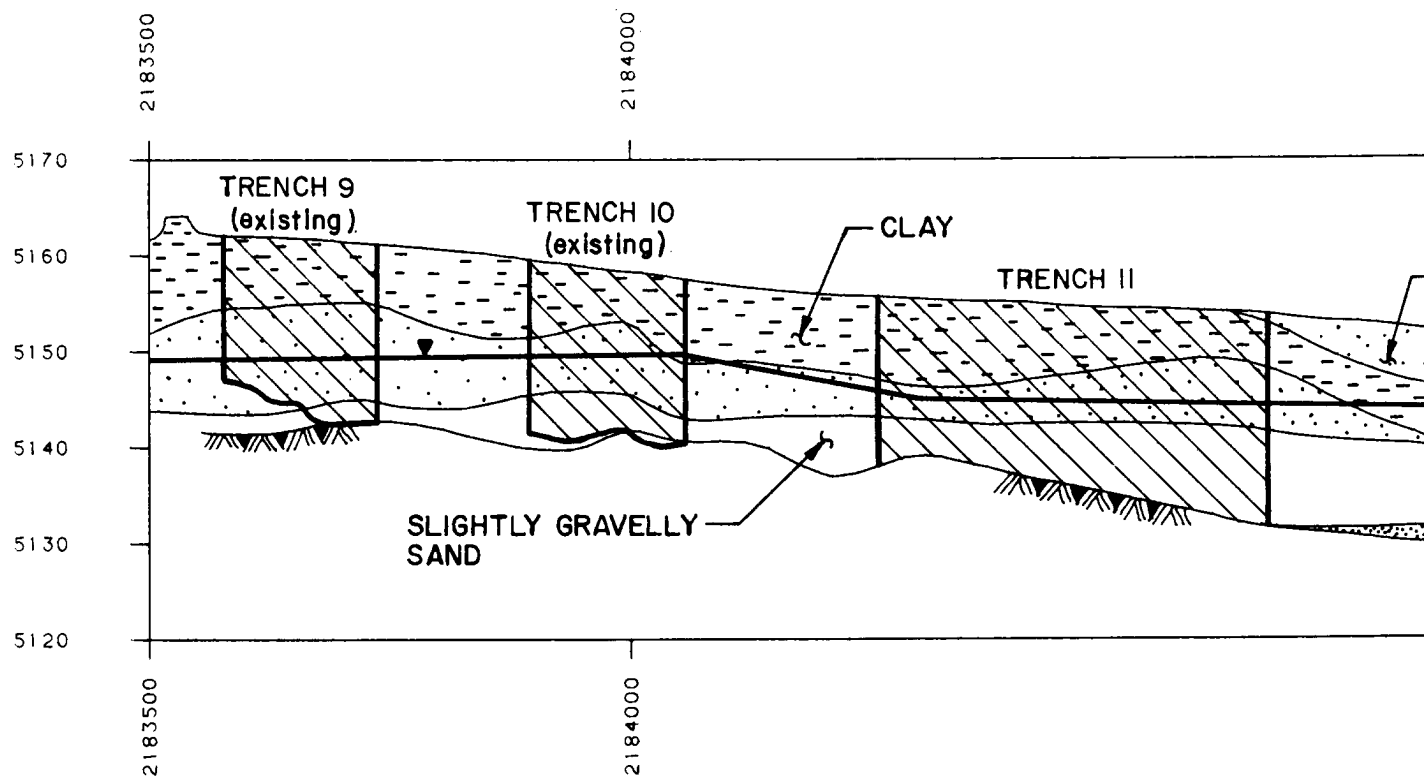
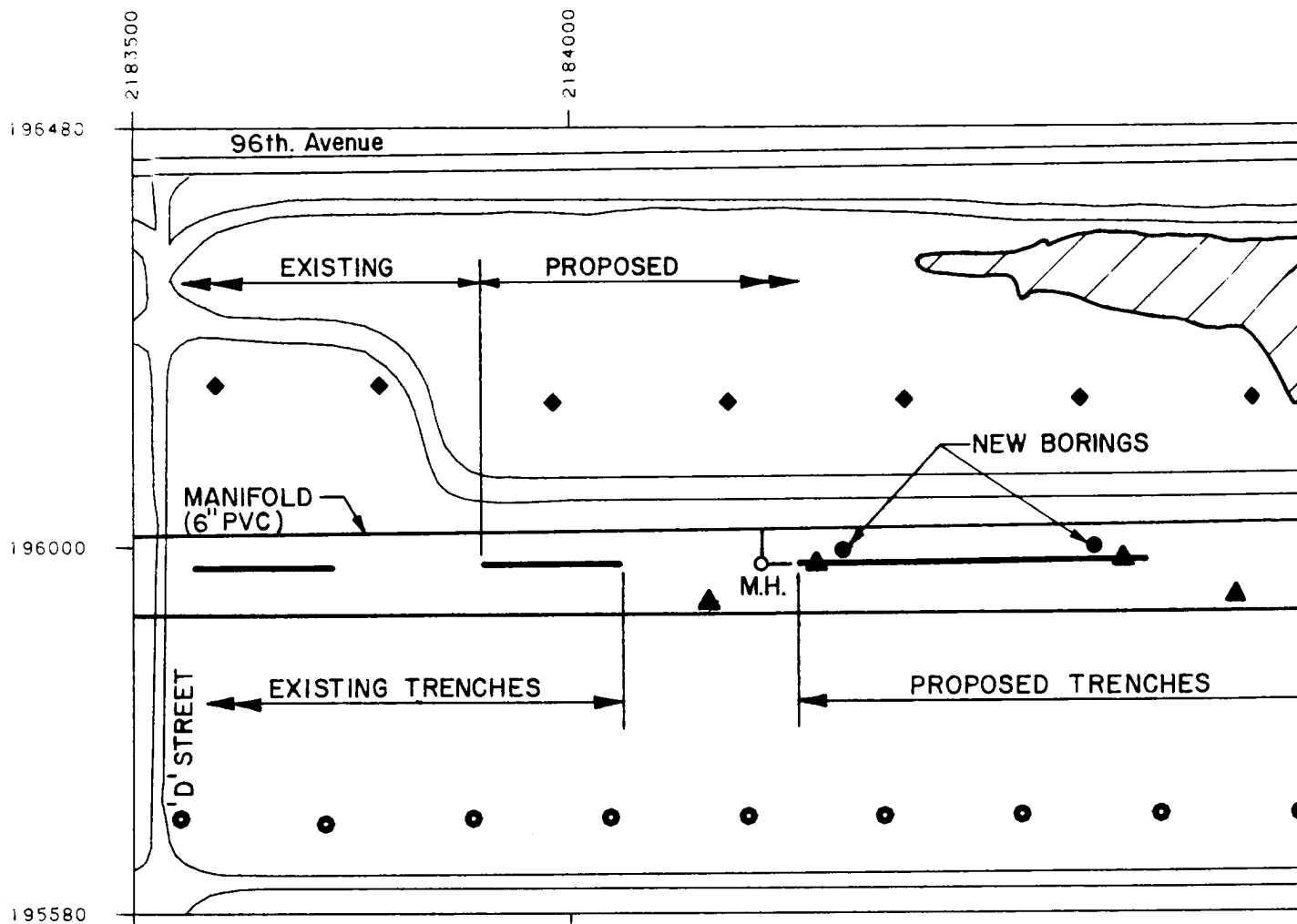

2185000

2186000

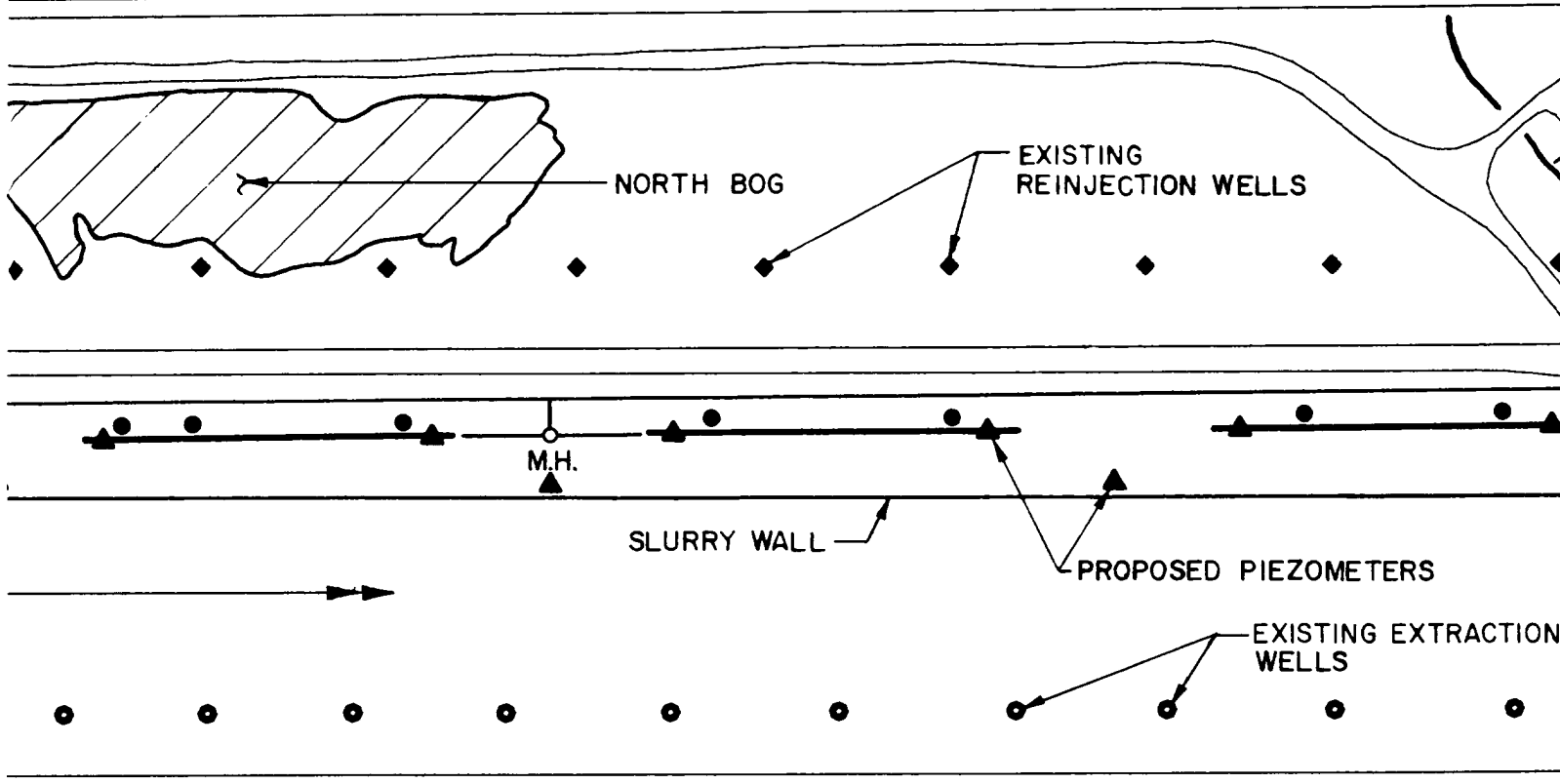

2185000

2186000

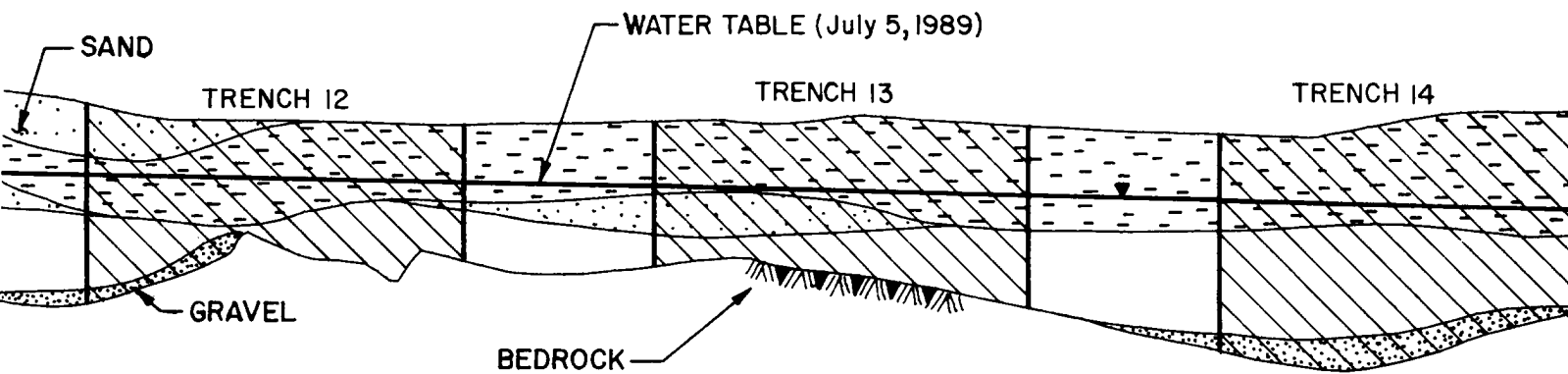

2185000

2186000

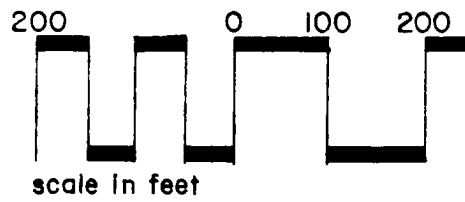
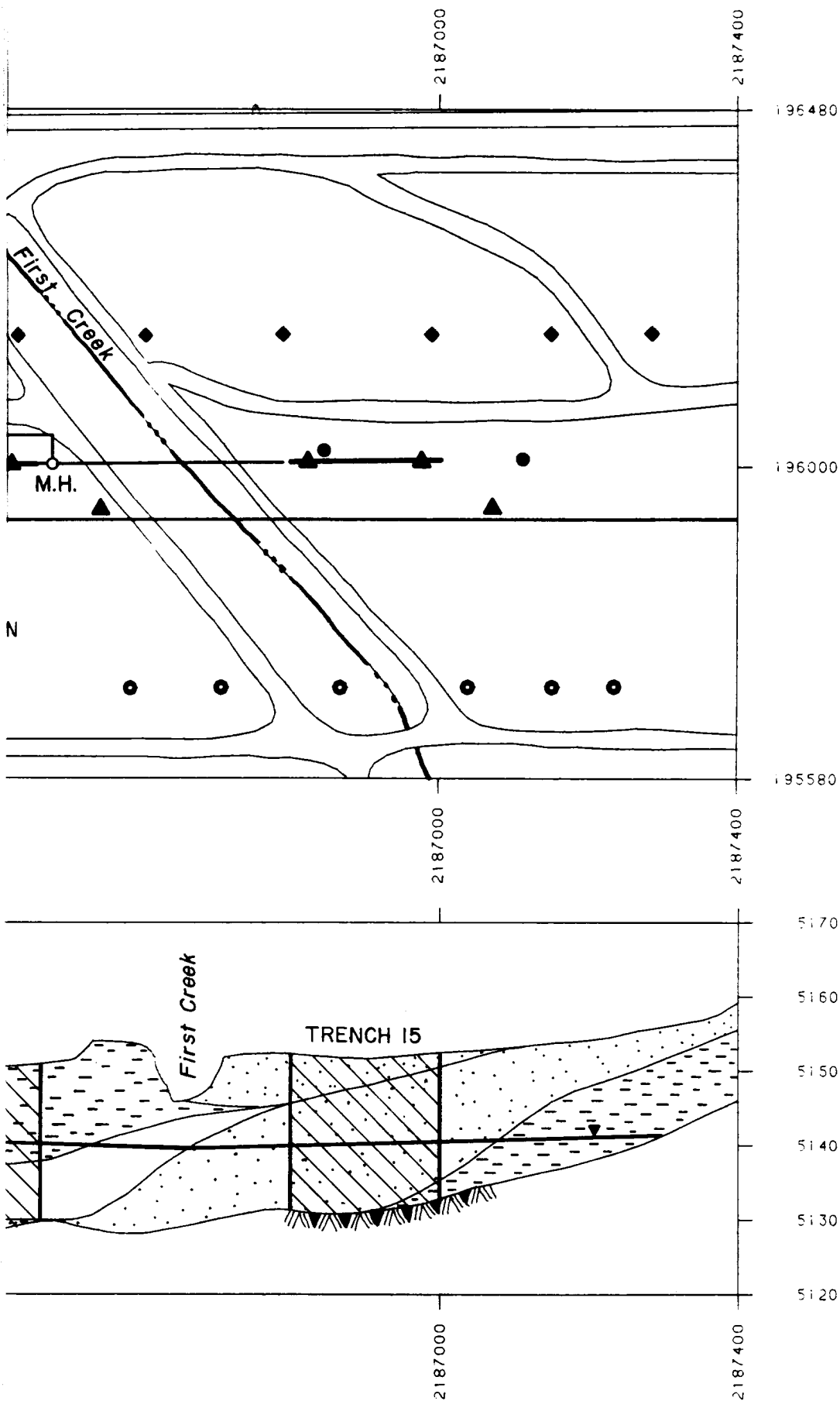

Rocky Mountain A
 Denver, Colorado

North Boundary System Im
IRA
 Figure 3
 Recharge Trench
 Plan and Profile

 **MK-ENVIRONMENTAL S**
 A DIVISION OF MK-FERGUSON

north

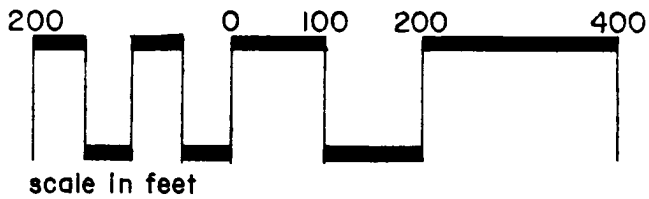

Rocky Mountain Arsenal

Denver, Colorado

North Boundary System Improvements

IRA

Figure 3

Recharge Trenches

Plan and Profile



MK-ENVIRONMENTAL SERVICES
A DIVISION OF MK-FERGUSON

The recharge trenches will be constructed using the working bench concept utilized during the construction of the 10 existing trenches and illustrated in Figure 4. This method of construction provides a flat working surface, lessens the depth of trench that must be constructed, and provides below ground storage for potentially contaminated materials that may be excavated from some of the trenches.

The recharge manifold serving the 10 existing recharge trenches has a diameter of six inches, and has adequate capacity for feeding the five proposed new trenches. The manifold will be extended to the east to serve these new trenches. During construction of the existing ten recharge trenches, spare control-wire cables were installed that can be extended to serve the new flowmeters.

With the completion of a recharge trench system extending along the entire North Boundary System, the flexibility with which treated water can be recharged in the areas desired will be significantly enhanced. Currently, because of the limited recharge capacity of the boundary system, recharge must be accomplished where possible. This lack of flexibility can create problems. For example, the North Bog is currently used for recharging a significant amount of treated water. There is speculation that this has at least contributed to a high water table on private property just north of the Arsenal. The increased recharge flexibility that will be provided by the new trenches may help eliminate such problems.

Because of the benefits expected to result from the use of the recharge trenches and the relative simplicity of their design and construction, consideration is being given to expedite their construction. In such a case, the Implementation Document for the North Boundary System Improvements IRA would be issued in two parts. The first part would relate to the implementation of the recharge trenches and associated appurtenances such as the

Potentially Contaminated
Stockpile

Existing Ground Level

2' min.
6' max.

Excavation

Rocky Mountain Arsenal

Denver, Colorado

North Boundary System Improvements IRA

Figure 4
Cross-Section Showing Work Bench
Construction Concept

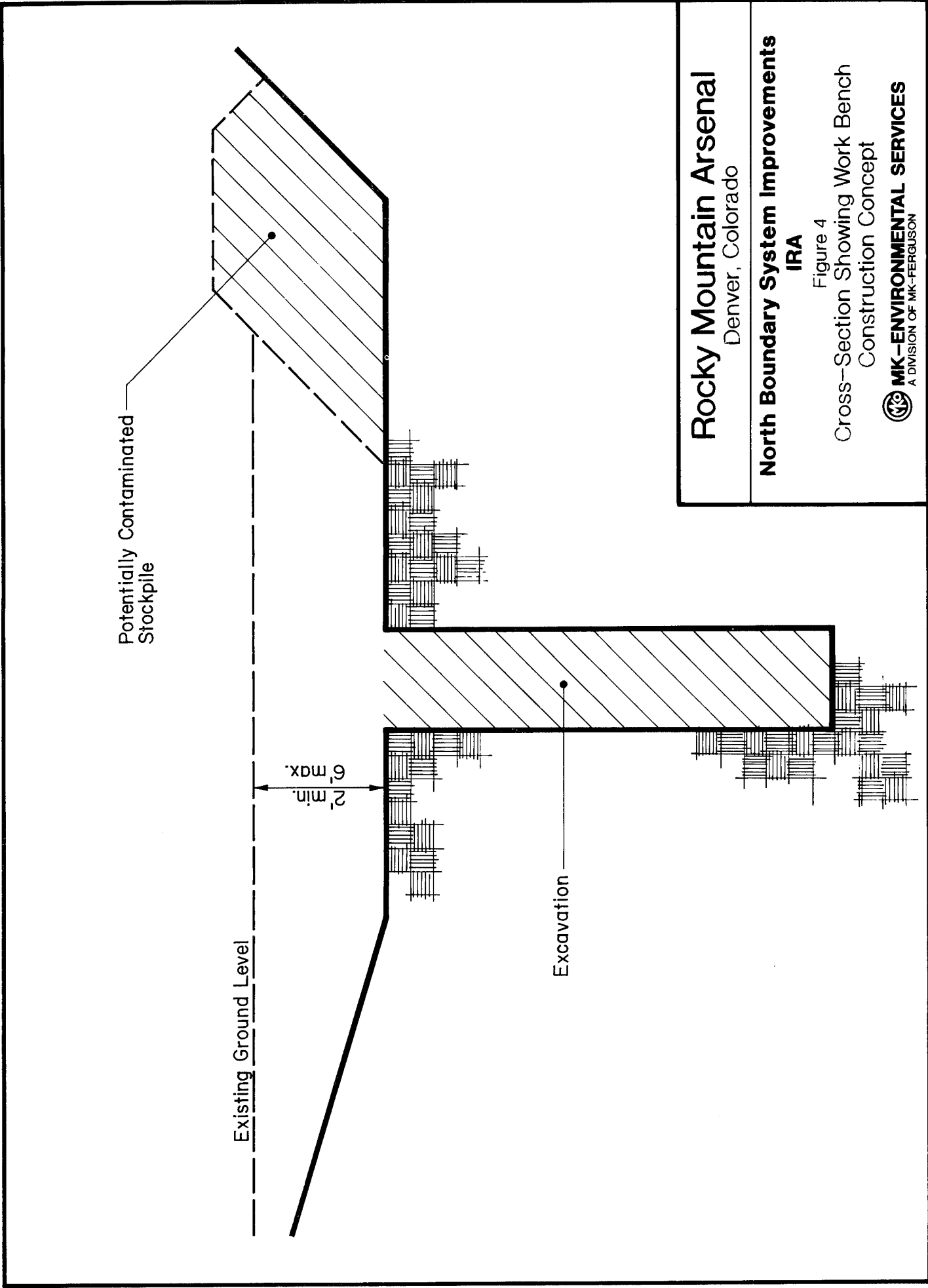

treated water manifold and the observation wells. The second part would relate to all remaining portions of the IRA described in this preliminary design report. Dividing the Implementation Document and construction into two separate parts would not affect any Deadlines that the entire IRA is expected to meet, but would eliminate the need to hold up the design and construction of the needed recharge trenches for the more complicated design and construction associated with treatment plant modifications.

3.2 DEWATERING SYSTEM IMPROVEMENTS

Information available regarding the existing dewatering wells and water table indicates that the existing dewatering system can be used to lower the alluvial water table below current levels along most or all of the boundary system. During August 1989, some of the probe settings and pump elevations in the dewatering system are being lowered so as to more fully utilize the capacity of the existing dewatering wells. So far, the need for additional dewatering capacity has not been demonstrated. Changes in pumping rates and consequential water table changes will continue to be monitored closely, and further operational changes will likely be made in pump and/or probe settings and treatment plant flows. Consequently, at this time no augmentation to the dewatering system is planned. If the desirability of adding new dewatering capacity to the North Boundary System is demonstrated as the consequences of these operational changes are observed, such capacity can be installed.

3.3 WELL CLOSURE

In accordance with paragraph 22.1(d) of the Federal Facilities Agreement, an Interim Response Action for the closure of abandoned wells at the RMA has been implemented in which wells in the vicinity of the North Boundary System (and other areas)

having the potential to act as conduits for the cross-contamination between the alluvial and Denver Formation aquifers were closed. Despite some significant efforts, some of the wells selected for closure were not found. If deemed appropriate, those wells which are located during construction activities associated with this IRA will be closed in accordance with procedures developed for the abandoned well closure IRA. A listing of wells that could potentially be encountered follows:

24059	24132
24060	24133
24061	24134

3.4 DESIGN FLOW RATE

A design flow rate of 350 gallons per minute (gpm) was selected for the purpose of sizing the treatment plant components discussed in Section 3.5 below. This design flow rate was developed utilizing historical flow and water level data, and some assumed operational factors.

For the fiscal years 1984 through 1987, the average flow pumped and treated at the North Boundary System was 231 gpm. During this period, groundwater levels on the south side of the slurry wall actually declined at a rate estimated to average about 18 gpm. The design flow rate, however, should be higher than the historical regional flow rate towards the boundary system in order to provide capacity required to effect changes in the water table when desired, compensate for plant downtime, compensate for seasonal variations in the groundwater flux, and account for the fact that creation of the reverse hydraulic gradient across the slurry wall may result in leakage towards the system and eliminate leakage past the North Boundary. After considering the various factors relative to treatment capacity, a value of 350 gpm was selected as being the recommended design flow rate. For comparison purposes, monthly flow rates through

the North Boundary System treatment plant have not exceeded 300 gpm since January 1987, and only occasionally exceeded 300 gpm prior to that time.

3.5 GROUNDWATER TREATMENT SYSTEM

3.5.1 Treated Groundwater IRA Standards

In Section 8.3.1 of the Final Decision Document for the North Boundary Containment System Improvements Interim Response Action, the Army selected existing "off the shelf" technology for implementation of the IRA, which the Army anticipates would achieve the following limitations at the point of reinjection of the treated groundwater:

<u>Compound</u>	<u>Groundwater IRA Standard (ug/L)</u>
Ethylbenzene	1,400
Carbon Tetrachloride	5
DBCP	0.2
Chloroform	100
DDT	10
1,2-Dichloroethane	5
1,1-Dichloroethylene	7
Dieldrin	0.12
Endrin	0.2
Hexachlorocyclopentadiene	206
Tetrachloroethylene	8
Toluene	14,300
DIMP	9,730
Trichloroethylene	5
Fluoride	4,000
Arsenic	50

Section 8.3.1 of the Final Decision Document also indicated that promulgated standards were not found for certain target analytes of this IRA. These target analytes include Benzothiazole, Chloride, p-Chlorophenylmethyl Sulfur compounds, Dicyclopentadiene, Dithiane, Isodrin, and Sulfate. It is anticipated, based on operating history at the existing treatment facility, that substantial treatment of the organic

compounds will occur. The treatment for removal of inorganic constituents is not an objective of this IRA and will be evaluated further as groundwater remedial action objectives are developed from results of the Off-Post RI/FS currently being finalized.

3.5.2 Existing Groundwater Treatment Process Description

Existing groundwater treatment process at the NBCS consists of influent pumping, pre-filtration, carbon adsorption, post-filtration, effluent pumping, wastewater handling and carbon storage/handling. Process flow diagrams showing the main process flows for the existing facility are shown on Figures 5 and 6. A brief description of the process is provided below.

The treatment process configuration consists of three parallel treatment trains providing dedicated treatment of the raw groundwater from extraction manifolds A, B, and C. Each train consists of an influent sump, an influent pump, a bank of cartridge pre-filters, and a carbon adsorber. The raw groundwater is collected in the influent sump and pumped by the influent pump to the cartridge pre-filter for removal of suspended solids. Filter effluent is discharged to the carbon adsorber for removal of organic contaminants. Flow to each adsorber is controlled using a local indicating flowmeter and a manual flow control valve. High level in the influent sump automatically shuts down all the operating well pumps in the respective extraction manifold. Low level in the influent sump automatically shuts down the respective influent pump.

Effluent from the three adsorbers are collected in a common header and discharged to the post-filtration system consisting of two parallel trains of cartridge and bag filters. One train is normally in operation while the second train is undergoing media change out or is on standby. The post-filtration effluent is collected in the effluent sump and pumped by one of two

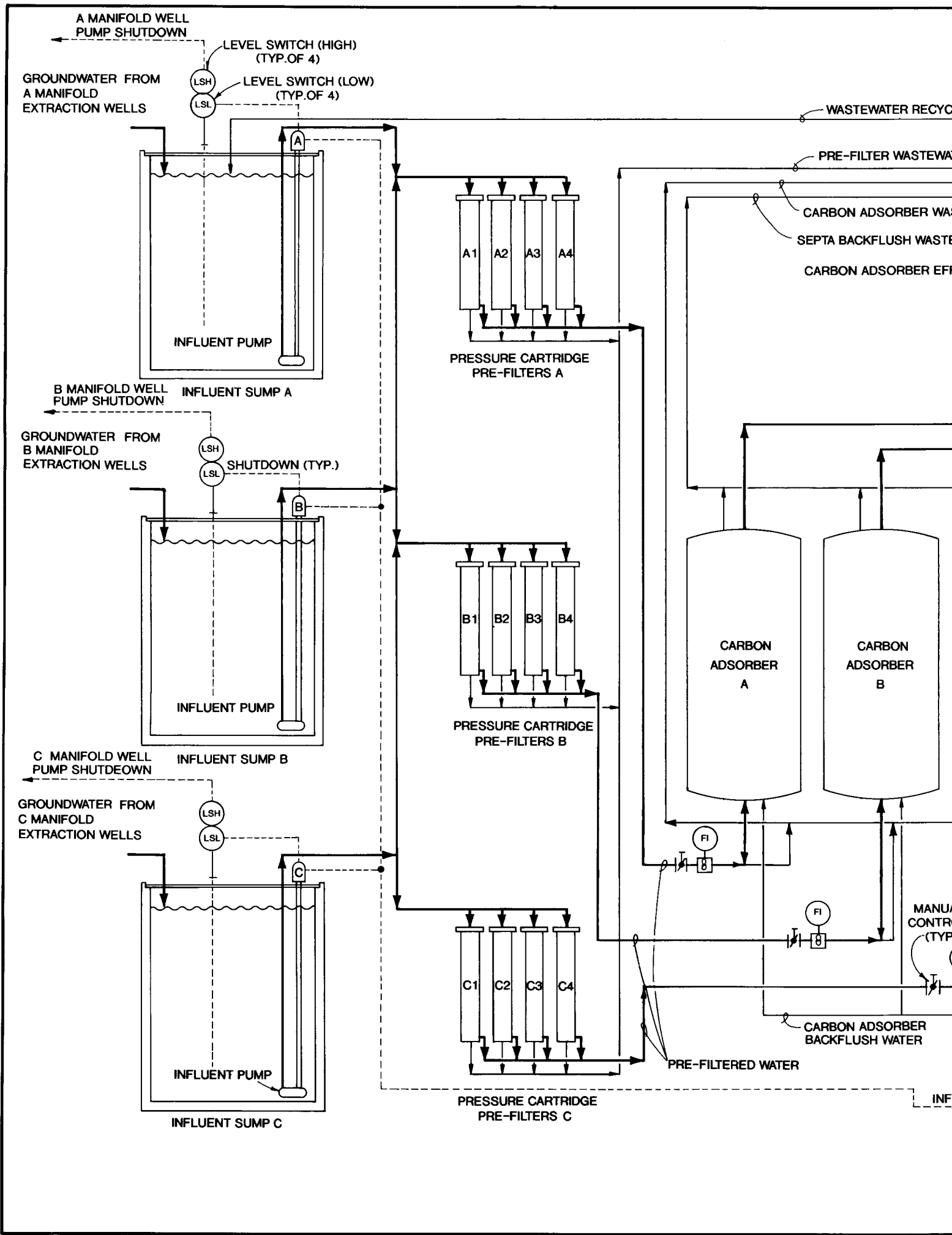

A MANIFOLD WELL
PUMP SHUTDOWN

LEVEL SWITCH (HIGH)
(TYP. OF 4)

GROUNDWATER FROM
A MANIFOLD
EXTRACTION WELLS

LSH

LEVEL SWITCH (LOW)
(TYP. OF 4)

LSL

INFLUENT PUMP

INFLUENT SUMP A

B MANIFOLD WELL
PUMP SHUTDOWN

GROUNDWATER FROM
B MANIFOLD
EXTRACTION WELLS

LSH

SHUTDOWN (TYP.)

LSL

INFLUENT PUMP

INFLUENT SUMP B

C MANIFOLD WELL
PUMP SHUTDOWN

GROUNDWATER FROM
C MANIFOLD
EXTRACTION WELLS

LSH

LSL

INFLUENT PUMP

INFLUENT SUMP C

A1 A2 A3 A4

PRESSURE CARTRIDGE
PRE-FILTERS A

B1 B2 B3 B4

PRESSURE CARTRIDGE
PRE-FILTERS B

C1 C2 C3 C4

PRESSURE CARTRIDGE
PRE-FILTERS C

CARBON
ADSORBER
A

CARBON
ADSORBER
B

FI

FI

MANU
CONTR
(TYP)

CARBON ADSORBER
BACKFLUSH WATER

PRE-FILTERED WATER

INF

WASTEWATER RECYC

PRE-FILTER WASTEW

CARBON ADSORBER WA

SEPTA BACKFLUSH WASTE

CARBON ADSORBER EFI

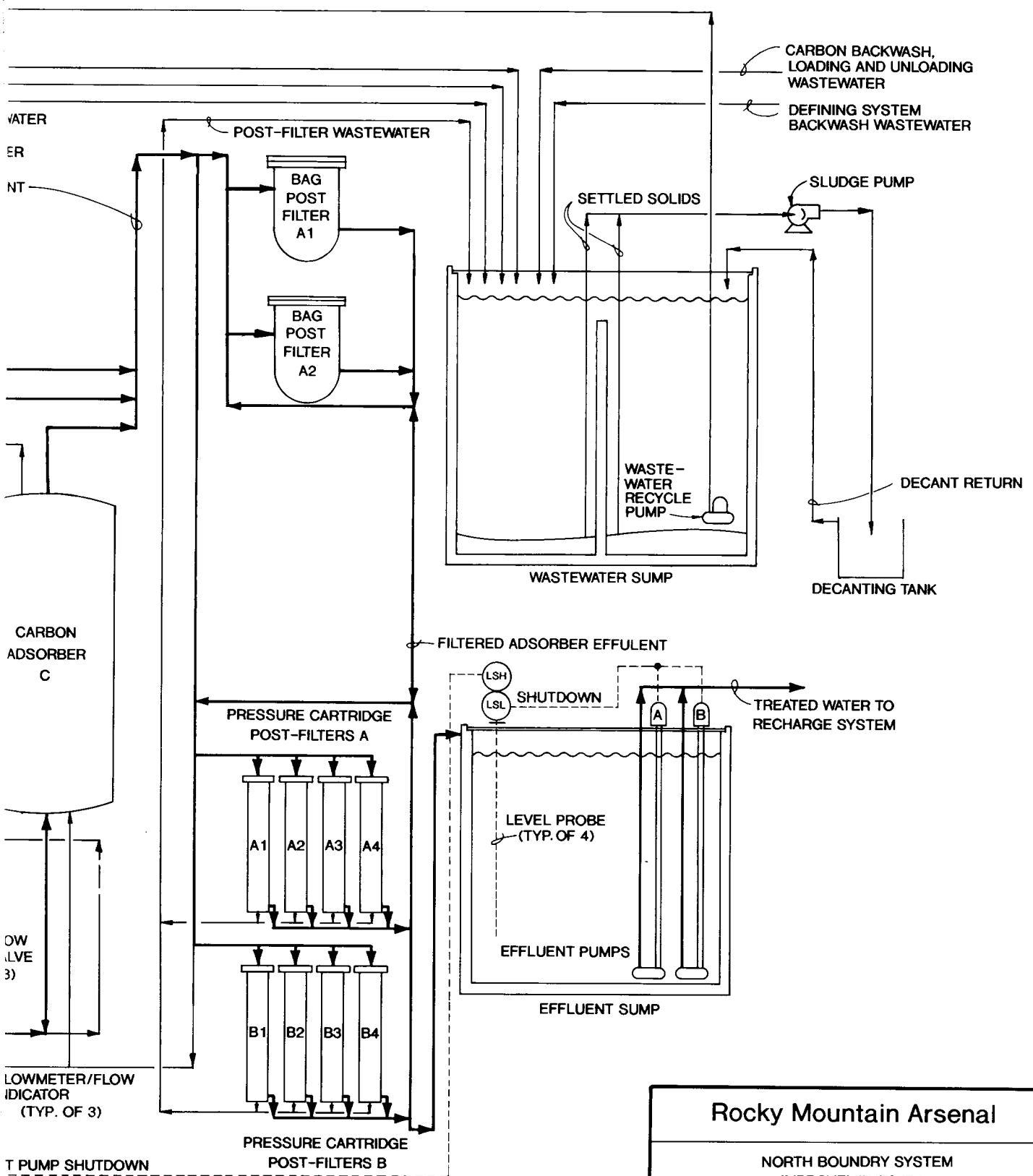

NOTES:
BOLD LINES DENOTE MAIN PROCESS FLOW

Rocky Mountain Arsenal

NORTH BOUNDARY SYSTEM IMPROVEMENTS IRA

FIGURE 5

EXISTING GROUNDWATER TREATMENT PROCESS FLOW DIAGRAM

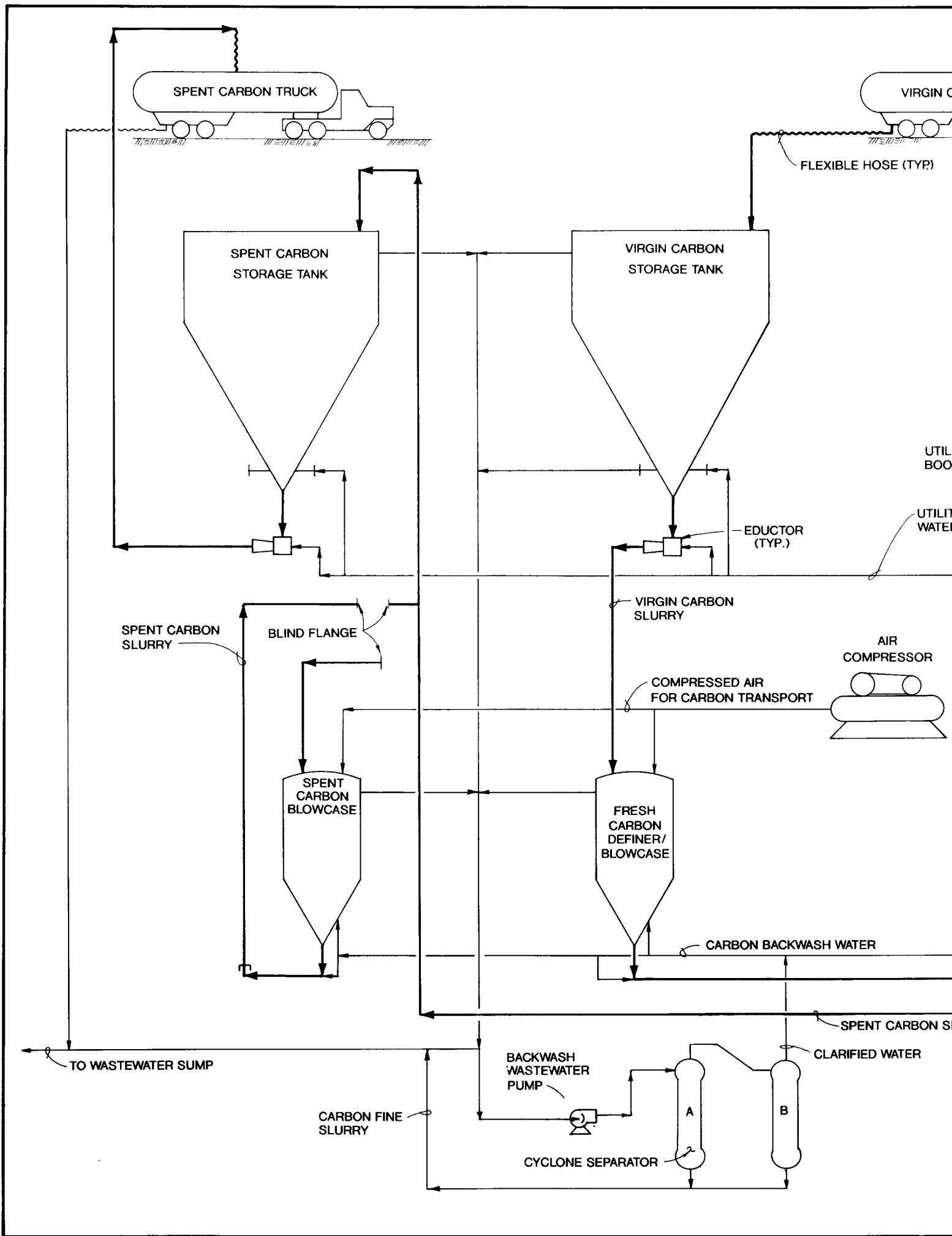

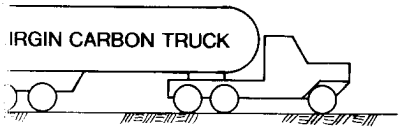

(YR)

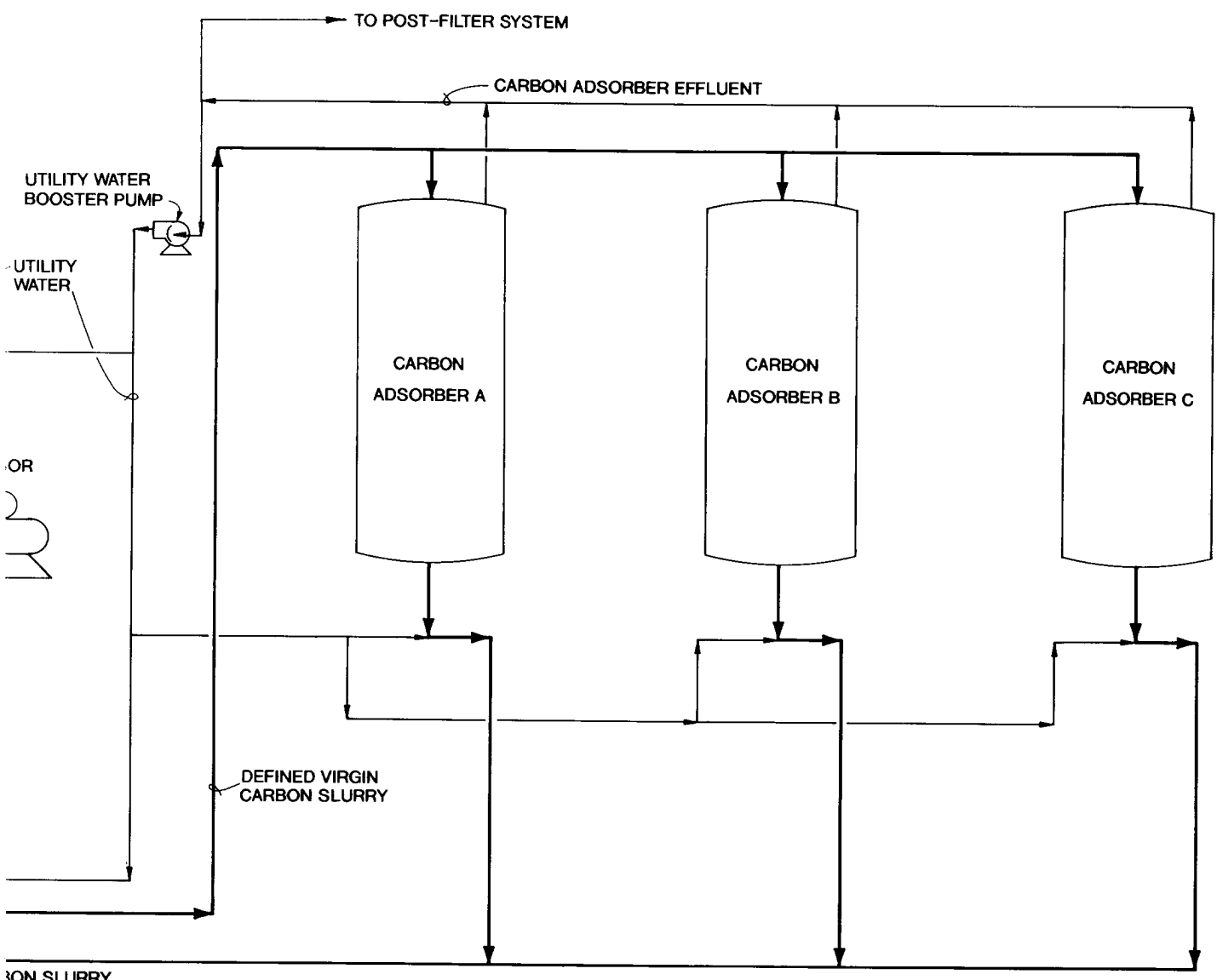

NOTE:
BOLD LINES DENOTE
MAIN PROCESS FLOW

Rocky Mountain Arsenal

NORTH BOUNDARY SYSTEM
IMPROVEMENTS IRA

FIGURE 6

EXISTING CARBON HANDLING
PROCESS FLOW DIAGRAM

effluent pumps to the groundwater recharge system. High level in the effluent sump automatically shuts down all operating influent pumps and essentially shuts down the entire groundwater treatment process. Low level in the effluent sump automatically shuts down the operating effluent pump.

The wastewater sump collects various wastewater discharges from the plant including floor drainage, virgin carbon backwash water, carbon adsorber septa backflush water, and carbon loading and unloading wastewater. The sump is operated as a batch system with decant being pumped to the influent sump following sedimentation.

The carbon adsorbers are pulsed bed units operating in the upflow mode. Spent carbon from the adsorber bottom is periodically removed or "pulsed" and stored in the spent carbon storage tank. The pulsed carbon is replaced by an equal amount of defined virgin carbon. The process involves transfer of virgin carbon from the virgin carbon storage tank into the virgin carbon definer/blowcase where the carbon is backwashed with carbon adsorber effluent. The defined carbon is then transferred to the carbon adsorber using compressed air as the transport medium.

3.5.3 Treatment System Modifications

As indicated in Section 4.2 of the Final Decision Document for this IRA, the NBS has proven very effective in the removal of organic contaminants from the groundwater as evidenced by data presented in North Boundary System Component Response Action Assessment Draft Final Report (ESE, 1988). The NBCS consistently removed organic contaminants to concentrations below their respective certified reporting limits. However, it was also concluded that carbon fines generation within the plant was contributing to plugging of recharge wells and reduced efficiency of plant operations.

MK-Environmental Services (MKE) undertook a comprehensive investigation of the existing treatment system design and operation to determine the specific modifications required for improvement of system operation and reliability. An independent and parallel investigation was also performed by Rubel Engineering, Inc. under contract to the Office of the Program Manager for the Rocky Mountain Arsenal. The recommendations of this investigation are contained in Report on On-Site Engineering Study of the Carbon Adsorption Treatment Unit at the North Boundary Control System at Rocky Mountain Arsenal (Rubel, 1989). MKE has evaluated the recommendations of this report and, where appropriate, has incorporated these recommendations into the planned modifications presented below.

3.5.3.1 It is planned to use only two of the existing three adsorbers for treatment of groundwater extracted by the boundary containment system. This modification is feasible since it is no longer required to provide dedicated treatment of groundwater from each extraction manifold. Such an operational scheme allows for utilization of the third adsorber as a standby unit which can be brought on-line in the event an operating adsorber requires maintenance. Possible maintenance requirements of an adsorber include: vessel liner inspection and repair; outlet septa cleaning and/or replacement; and inlet septa cleaning and/or replacement. This configuration also allows for pulsing of spent carbon without interruption of plant operation. Flow is manually transferred to the standby unit whenever pulsing of an operating adsorber is required.

The plant design flowrate is 350 gpm based on hydrologic requirements of the boundary system as presented in Section 3.4 of this report. Under the

planned operating scheme utilizing only two adsorbers, each adsorber is required to treat a maximum of 175 gpm of groundwater. At this flowrate, each adsorber provides a hydraulic loading rate of 2.2 gpm/ft² and an empty bed contact time of approximately 43 minutes. Both parameters are within the generally accepted ranges for adsorber operation.

Conversion of the treatment plant to operation with two adsorbers requires modification of the influent sump and pumping systems. The current treatment process, as described earlier, employs a separate influent sump and pump for feed of each adsorber. Modification is required to allow for collection of groundwater from all three extraction manifolds in a single sump. Formation of a single sump is accomplished through connection of the three existing influent sumps. A sufficient number of openings are provided in the two interior walls separating the three existing sumps. This allows the existing three sumps to operate as a single larger sump. The larger sump is beneficial in equalizing of treatment flows and management of combined fluoride and chloride concentrations.

With a single influent sump, the possibility exists for feeding of each adsorber with any of the three existing influent pumps. This operational flexibility is realized through minor modifications to existing piping which are shown on Figure 7. Similar to current operation, one adsorber will continue to be fed by one influent pump. Head loss calculations through existing piping indicated the existing pumps to be adequate for feeding of the adsorbers at the increased flow of 175 gpm.

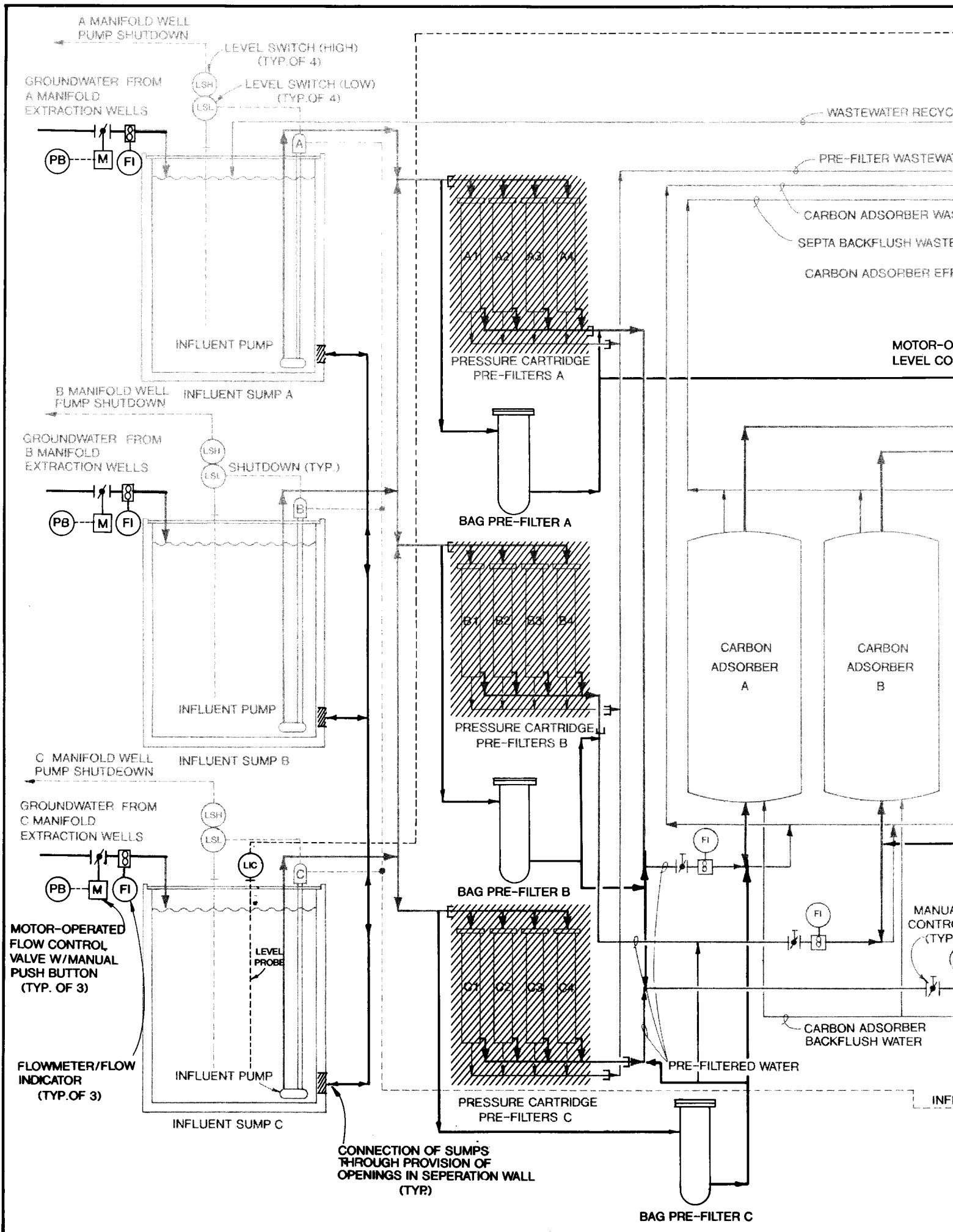

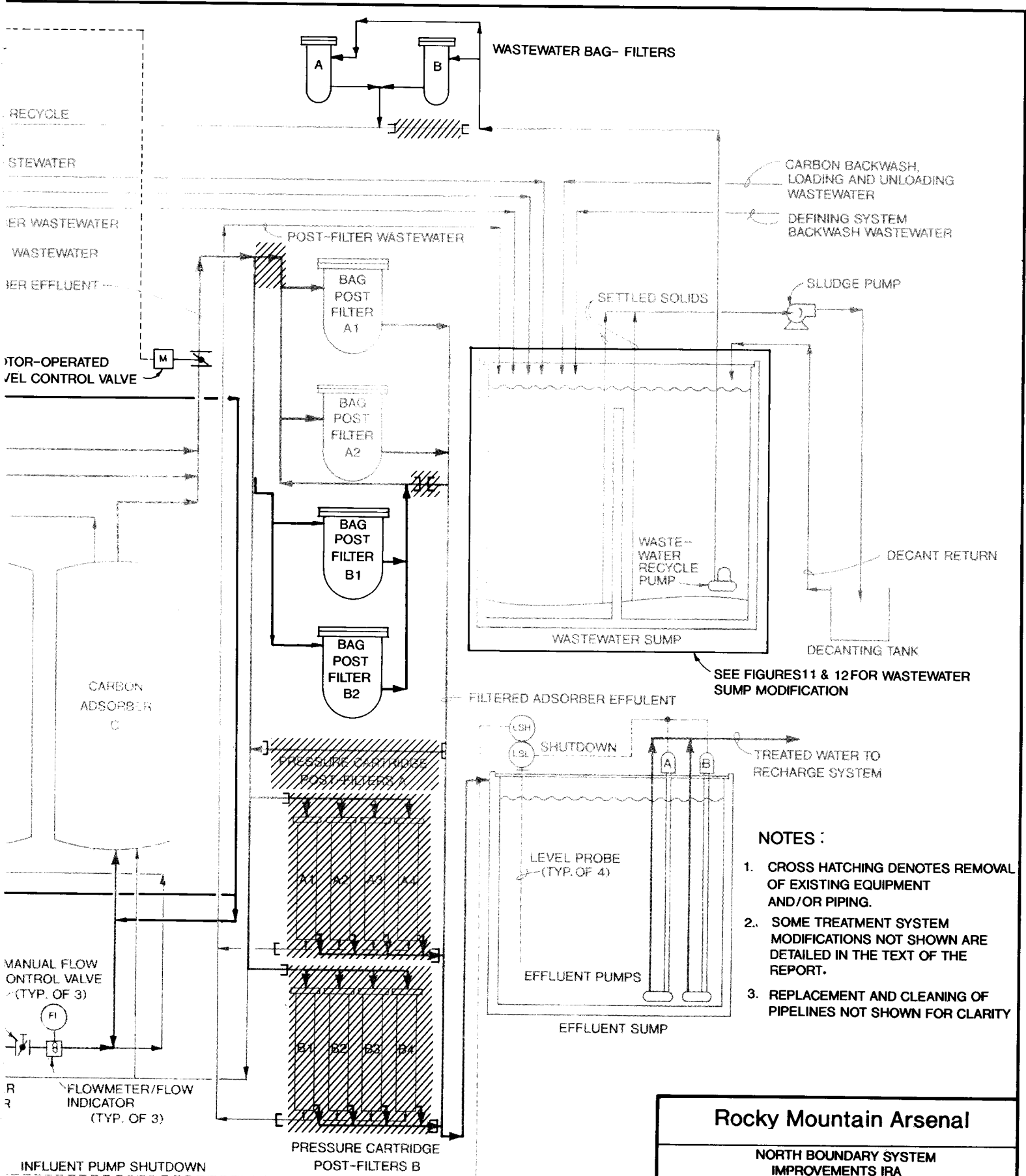

CARBON BACKWASH, LOADING AND UNLOADING WASTEWATER
 DEFINING SYSTEM BACKWASH WASTEWATER

SEE FIGURES 11 & 12 FOR WASTEWATER SUMP MODIFICATION

NOTES :

1. CROSS HATCHING DENOTES REMOVAL OF EXISTING EQUIPMENT AND/OR PIPING.
2. SOME TREATMENT SYSTEM MODIFICATIONS NOT SHOWN ARE DETAILED IN THE TEXT OF THE REPORT.
3. REPLACEMENT AND CLEANING OF PIPELINES NOT SHOWN FOR CLARITY

NOTES:
 BOLD LINES DENOTE MAIN PROCESS FLOW

Rocky Mountain Arsenal
 NORTH BOUNDARY SYSTEM IMPROVEMENTS IRA
 FIGURE 7
MODIFIED GROUNDWATER TREATMENT PROCESS FLOW DIAGRAM

3.5.3.2 It is planned to improve pre-filtration efficiency by replacing the existing pressure cartridge pre-filters with pressure bag pre-filters. This planned filter system replacement is shown on Figure 7. The plant recently switched from 100 micron filter cartridges to 10 micron filter cartridges for improvement of pre-filtration efficiency. The same 10 micron rating is maintained with the planned bag filtration system. Experimentation of varying micron ratings is possible with the housings provided to optimize solids removal and length of filter runs.

Numerous spent filter cartridges have been inspected and, on most of these cartridges, there was evidence of carbon fines leakage either through the filter element or around the end seals. This leakage of carbon fines has resulted in partial plugging of the adsorber inlet screens and carbon bed.

Dismantling of piping downstream of the pre-filtration system recently revealed a carbon and scale lining inside the piping that had reduced the effective diameter of the 4-inch line to almost 3 inches. Surges in flow resulting from plant start-up and shut-down apparently dislodges this lining. The pieces of lining eventually become lodged in the adsorber inlet screen, creating excessive head loss.

Pressure drops across Adsorber B have been observed to be as high as 45 psi. This excessive head loss is speculated to be caused mostly by plugging of the inlet screens since normal head loss with clean inlet screens is generally below 15 psi. The inlet screens are backflushed weekly to reduce the head loss. However, the excessive head loss eventually becomes irreversible and the screens have to be removed for manual cleaning

or replacement. Such maintenance requires lengthy shut-downs of the affected adsorber.

Both the North Boundary and Irondale Containment Systems currently use pressure bag-filters for post-filtration following adsorption. Based on operating experience, this type of filter is very reliable and, in general, produces less volume of waste than cartridge filters. The only notable problems with this type of filter results from use of inferior bags which eventually break and allow pass-through of suspended solids. Purchase of higher quality bags has virtually eliminated this problem.

It is planned to replace two of the three existing cartridge filter banks with the two existing bag filters of the post-filtration system. As discussed later in this section, the existing bag post-filters, rated for 400 gpm capacity, are undersized with respect to the flow requirements of the modified treatment system and would require replacement with larger size units. Reuse of these post-filters as pre-filters allows for utilization of existing equipment and results in substantial cost savings. Under this configuration, only one additional 400 gpm bag filter is needed to replace the third bank of cartridge filters.

- 3.5.3.3 It is planned to replace or mechanically clean existing influent piping to the pre-filters and adsorbers for improvement of system headloss. Under this modification, existing 3-inch piping to the pre-filters is removed and replaced with 4-inch piping. Layout of new piping will attempt to minimize the number of 90-degree bends within the system. The remaining 4-inch influent piping to the pre-filters and adsorbers

is mechanically cleaned through pigging. Pig launches and traps are installed in the new and existing piping to facilitate present as well as future cleaning.

The wastewater from pipe cleaning operations is discharged to the wastewater sump for treatment. Existing piping removed from the system is cleaned for disposal in accordance with project requirements.

- 3.5.3.4 It is planned to modify the automatic control of the treatment system to allow for setting of flows from each of the three well extraction manifolds. This modification is critical to the control of fluoride levels in the combined groundwater since the average fluoride concentrations vary significantly from manifold to manifold. The Army is currently required to discharge treated groundwater with fluoride levels below 4 mg/l. This discharge standard will be maintained following implementation of this IRA.

A flowmeter and a motor-operated flow control valve is installed in the header piping of each well extraction manifold. The flowmeters and control valves are housed in an underground meter vault located near the influent sumps. Remote indication and totaling of flow from each manifold is provided by a flow indicator/totalizer located inside the control room of the existing treatment building. An open/close pushbutton station located in close proximity to the respective flow indicator/totalizer provides for remote control of the motor-operated flow control valve.

A flowmeter and manual flow control valve exists in the influent line to each adsorber downstream of the pre-filtration system. The flow control system is utilized in the modified treatment system to split the total

plant flow evenly between two operating adsorbers. The total flow to the adsorption system is controlled to approximate the total plant influent flow. Since the discharge of the groundwater extraction system is somewhat variable, accurate and continuous flow matching of plant influent flow with adsorption system influent flow is not possible. The resultant effect is periodic shutdown of either the extraction system or treatment plant based on influent sump level. To prevent these occurrences, a level control valve is planned for installation in the adsorption system effluent header. This valve will modulate automatically based on influent sump level as controlled by a new level probe and level indicating controller. The level control valve will be equipped with travel stops to maintain a minimum preset flow to each operating adsorber. Under this operating scenario, neither the extraction wells nor treatment plant will experience automatic shutdown as long as the influent flow exceeds the minimum preset flow to each adsorber. The instrumentation and control modifications as discussed are presented in Figure 7.

- 3.5.3.5 It is planned to provide an additional 4000 pounds of virgin and spent carbon storage capacity by adding a three foot extension to the existing virgin and spent carbon storage tanks. Presently, the virgin carbon storage tank must be almost empty prior to receipt of a tank truck shipment of virgin carbon. The lack of excess storage capacity reduces the operational flexibility of the treatment plant with respect to scheduling of carbon shipments. Addition of the additional storage capacity would provide the required flexibility. These tank extensions are shown schematically on Figure 8.

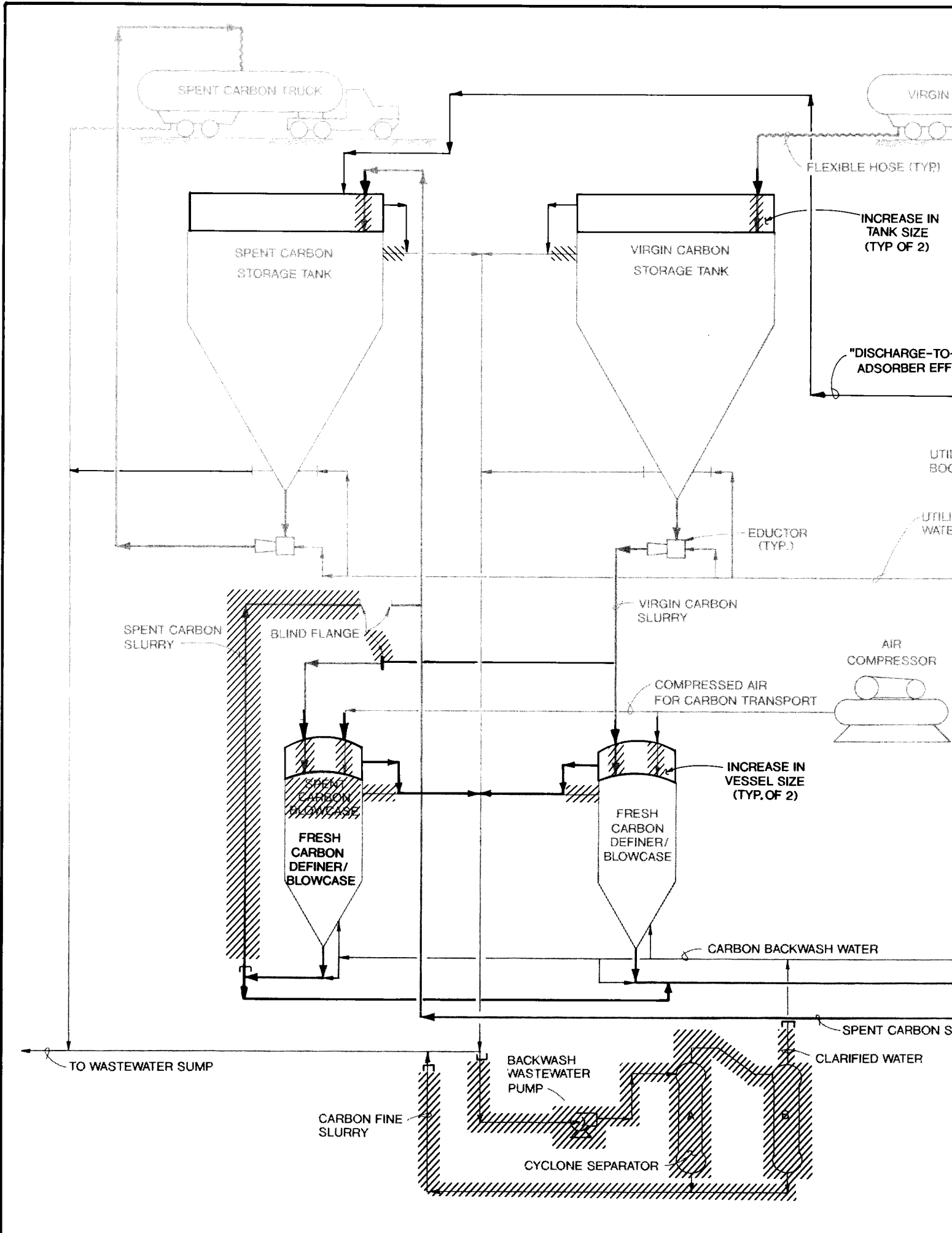

NOTES:

1. CROSS HATCHING DENOTES REMOVAL OF EXISTING EQUIPMENT AND/OR PIPING.
2. SOME TREATMENT SYSTEM MODIFICATIONS NOT SHOWN ARE DETAILED IN THE TEXT OF THE REPORT.

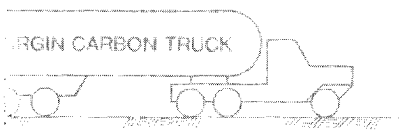

TYP)

E IN
ZE
2)

BE-TO-WASTE"
ER EFFLUENT

UTILITY WATER
BOOSTER PUMP

UTILITY
WATER

BOR

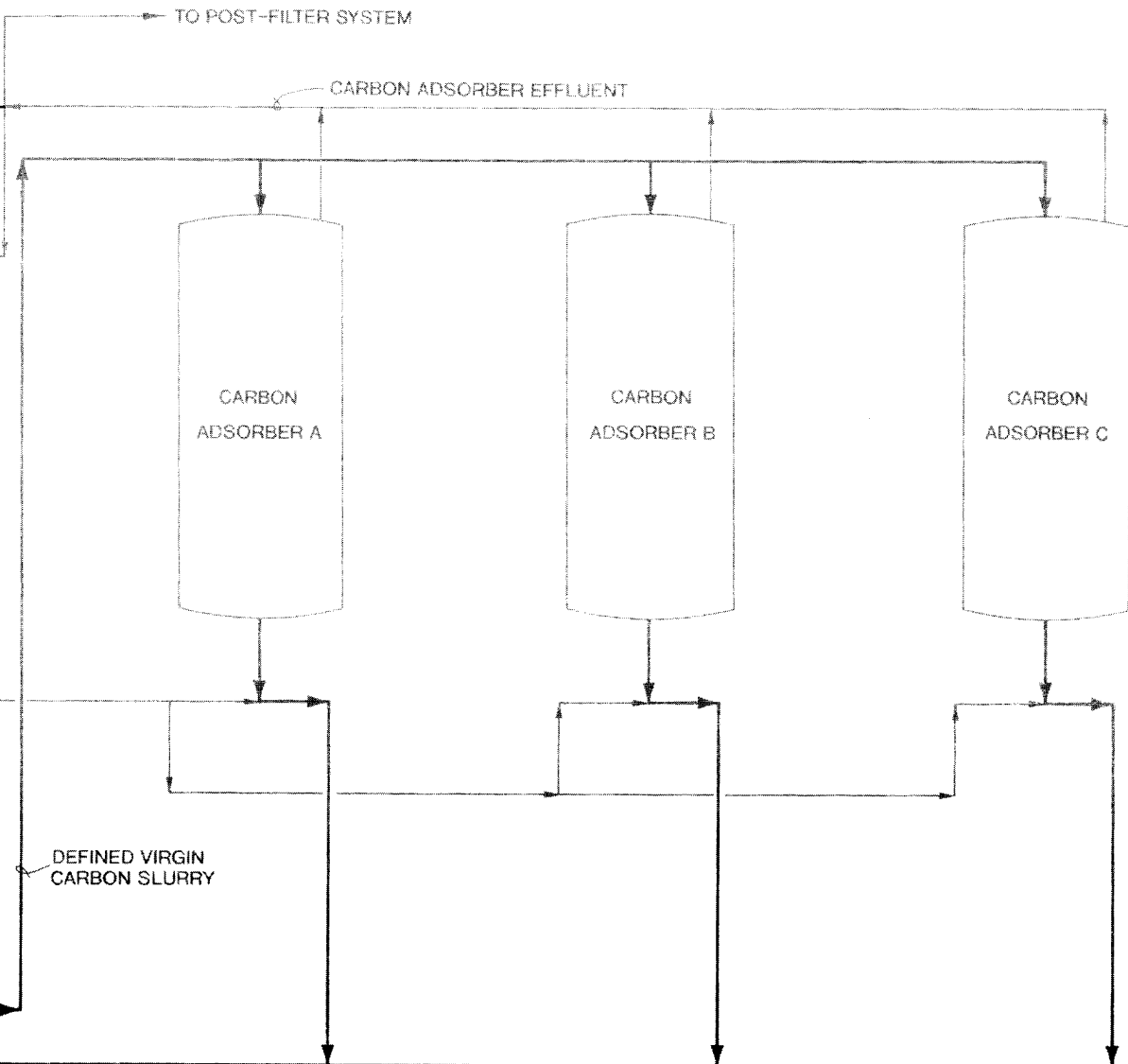

BON SLURRY

R

NOTE:
BOLD LINES DENOTE
MAIN PROCESS FLOW

Rocky Mountain Arsenal

NORTH BOUNDARY SYSTEM
IMPROVEMENTS IRA
FIGURE 8

MODIFIED CARBON HANDLING
PROCESS FLOW DIAGRAM



MK-ENVIRONMENTAL SERVICES
A DIVISION OF MK-FERGUSON

For prevention of internal corrosion, the 3-foot extensions to the storage tanks are provided linings similar to that of the existing tanks.

- 3.5.3.6 It is planned to replace the existing 1'-6" long adsorber outlet septas with 3'-6" units to minimize carryover of granular carbon particles to the post-filtration system and reduce head loss through the adsorbers. Sufficient submergence of the septa in the carbon bed is needed to effectively utilize the carbon bed for retention of small carbon particles within the adsorber. Submergence of the septas also prevents the smaller carbon particles from impinging on the septas which has been observed to substantially increase the head loss across the adsorber and, consequently, limit the maximum flow through the adsorbers.

The replacement septas utilize stainless steel well screen with 0.020 inch openings, unlike the existing septas that are constructed of a perforated stainless steel pipe wrapped with a plastic screen held in place by stainless steel clamps. The plastic screen is subject to tearing and/or movement along the perforated pipe which expose the perforations and allow carbon particles to exit the adsorber. Use of the stainless steel well screen will aid in preventing loss of carbon particles from the adsorbers.

In order to ensure complete submergence of the septa, well screen will constitute only the lower 2'-6" of the assembly with the remaining upper 1'-0" being constructed of stainless steel pipe.

- 3.5.3.7 It is planned to replace the existing adsorber inlet plate screens with cylindrical well screens for improvement of head loss through the adsorber inlet.

Preliminary calculations indicate a substantial head loss through each screen at the planned flowrate. The plate type screens are replaced with 1'-2" long cylindrical well screens with .020 inch openings to provide an approximate 600 percent increase in flow area, and thus reduce the adsorber inlet head loss.

- 3.5.3.8 It is planned to improve post-filtration efficiency by replacing the existing cartridge post-filters with bag post-filters. This planned filter system replacement is shown on Figure 8. As with the pre-filtration system, inadequate sealing of the ends of each filter cartridge can cause excessive leakage of fines from the filter system. Evidence of carbon fines accumulation in the effluent sump is probable indication of this leakage.

Both the North Boundary and Irondale Containment Systems currently use pressure bag-filters for post-filtration following adsorption. Based on operating experience, this type of filter is very reliable and, in general, produces less volume of waste than cartridge filters. The only notable problems with this type of filter result from use of inferior bags which eventually break and allow pass-through of suspended solids. Purchase of higher quality bags has virtually eliminated this problem.

In order to lengthen filter runs under operation of the modified treatment system, the new replacement bag filters are rated for 640 gpm capacity, or approximately 1.8 times the design flowrate of 350 gpm. For the same reason, it is also planned to replace the existing 400 gpm bag filters of the post-filtration

system with 640 gpm units. As discussed earlier in this section, the existing 400 gpm units are reused in the bag pre-filtration system.

It is further planned to utilize two-stage post-filtration for increased removal efficiency of smaller sized particles and for increased reliability against catastrophic leakage of suspended solids from the filtration system. Under this configuration, the two sets of two parallel filters are operated in series. The first stage and second stage filters are equipped with 10 and 5 micron filter bags, respectively. As shown in Figure 7, each stage contains two 100 percent capacity filters, with one in operation while the second is on standby or is undergoing filter bag replacement.

3.5.3.9 It is planned to provide elevated platforms and safety railing at strategic locations to improve access for performance of operating, maintenance, and sampling procedures. The approximate general arrangement and elevations of the platforms provided for the carbon adsorbers are shown on Figure 9. As shown, an elevated platform is installed with each adsorber to allow access to the top two sampling ports. The bottom sampling port is accessible from the floor of the treatment building. Safety railing installed at the top of each adsorber provides for safe access to piping, valves and access manways. The approximate general arrangement and elevation of the platform for the carbon storage tanks are shown on Figure 10. As shown, a single platform is provided between the virgin and spent carbon storage tanks to allow for access during carbon loading, unloading and pulsing procedures. Existing ladders on the adsorbers and storage tanks are utilized for access to the new

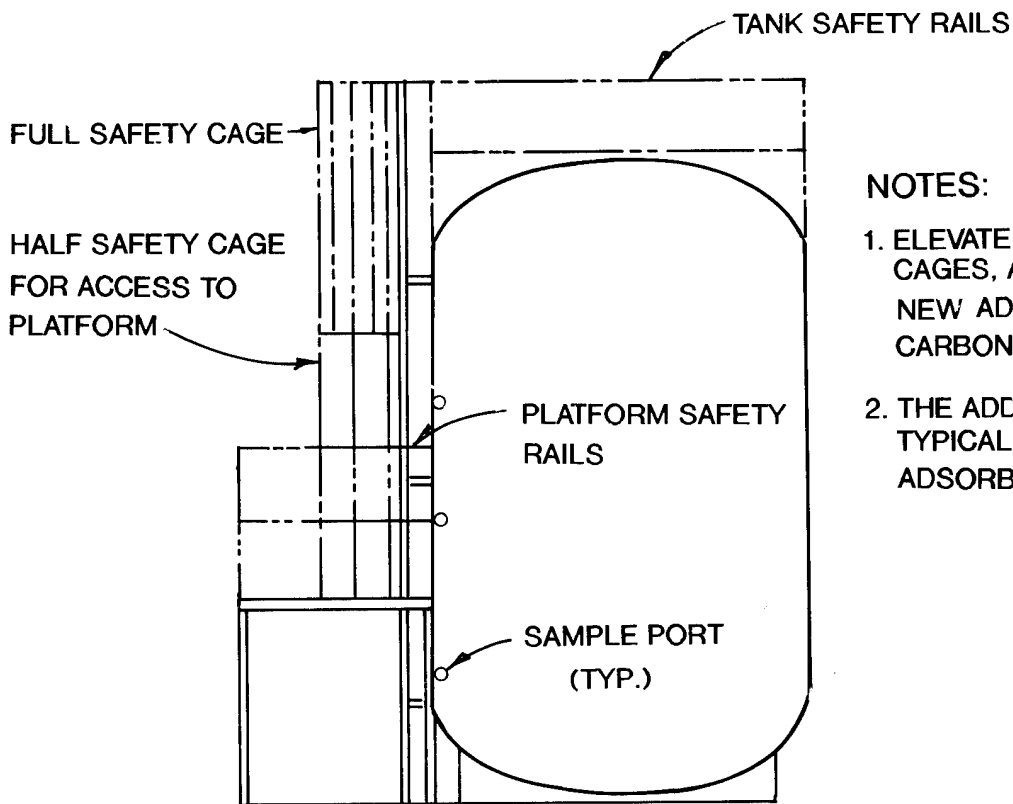
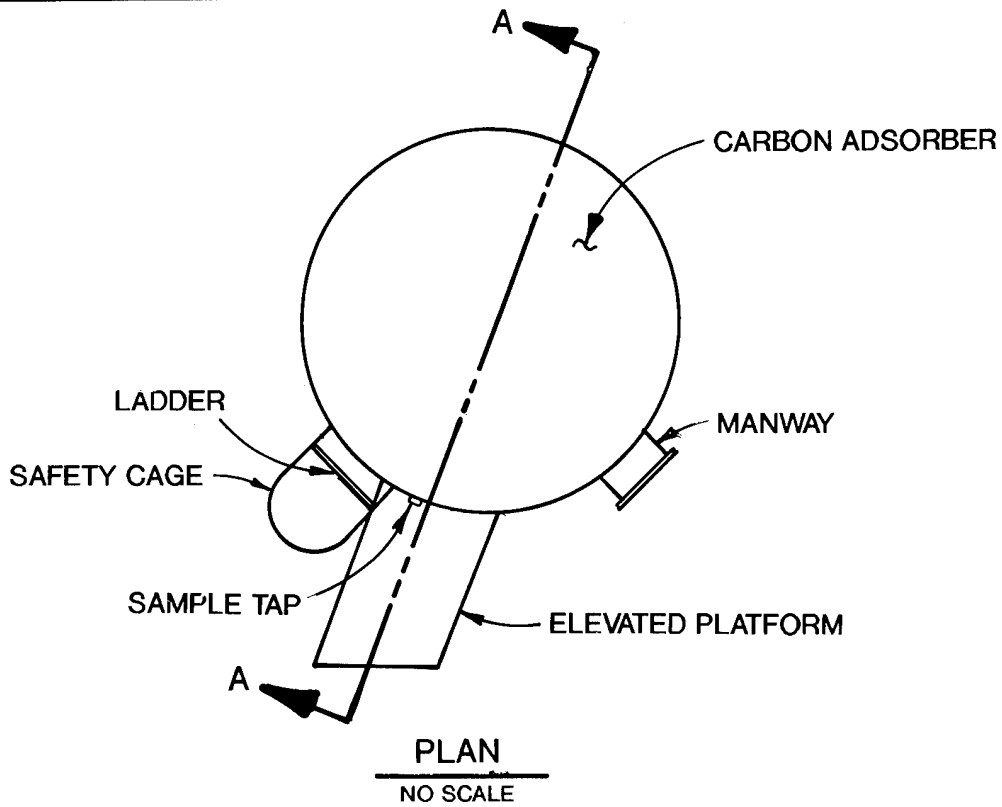

NOTES:

1. ELEVATED PLATFORMS, SAFETY CAGES, AND SAFETY RAILS ARE NEW ADDITIONS TO THE EXISTING CARBON ADSORBER.
2. THE ADDITIONS AS SHOWN ARE TYPICAL OF THREE CARBON ADSORBERS.

Rocky Mountain Arsenal
NORTH BOUNDARY SYSTEM IMPROVEMENTS IRA
FIGURE 9
CARBON ADSORBER ACCESS PLATFORM
MK-ENVIRONMENTAL SERVICES A DIVISION OF MK-FERGUSON

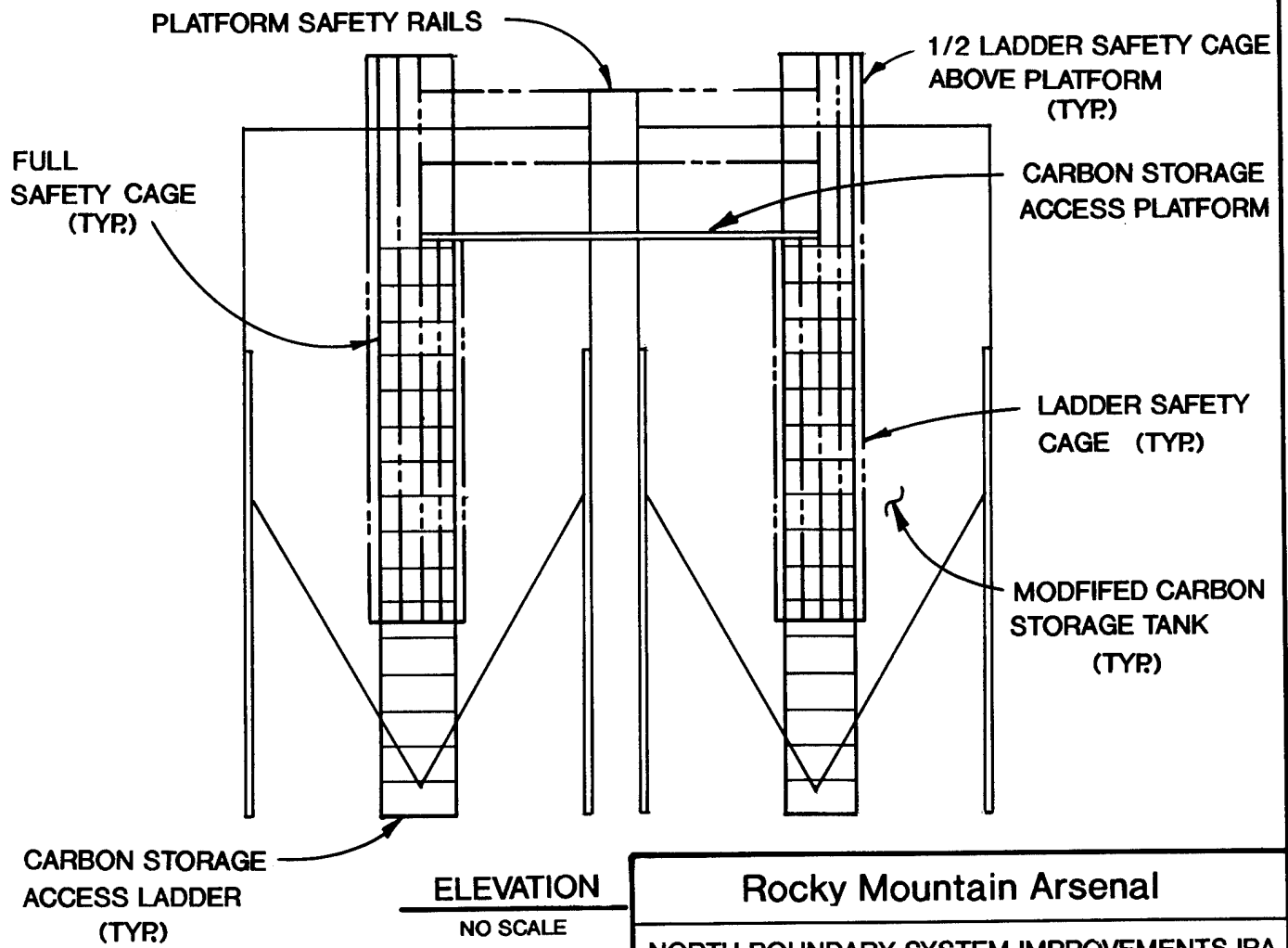
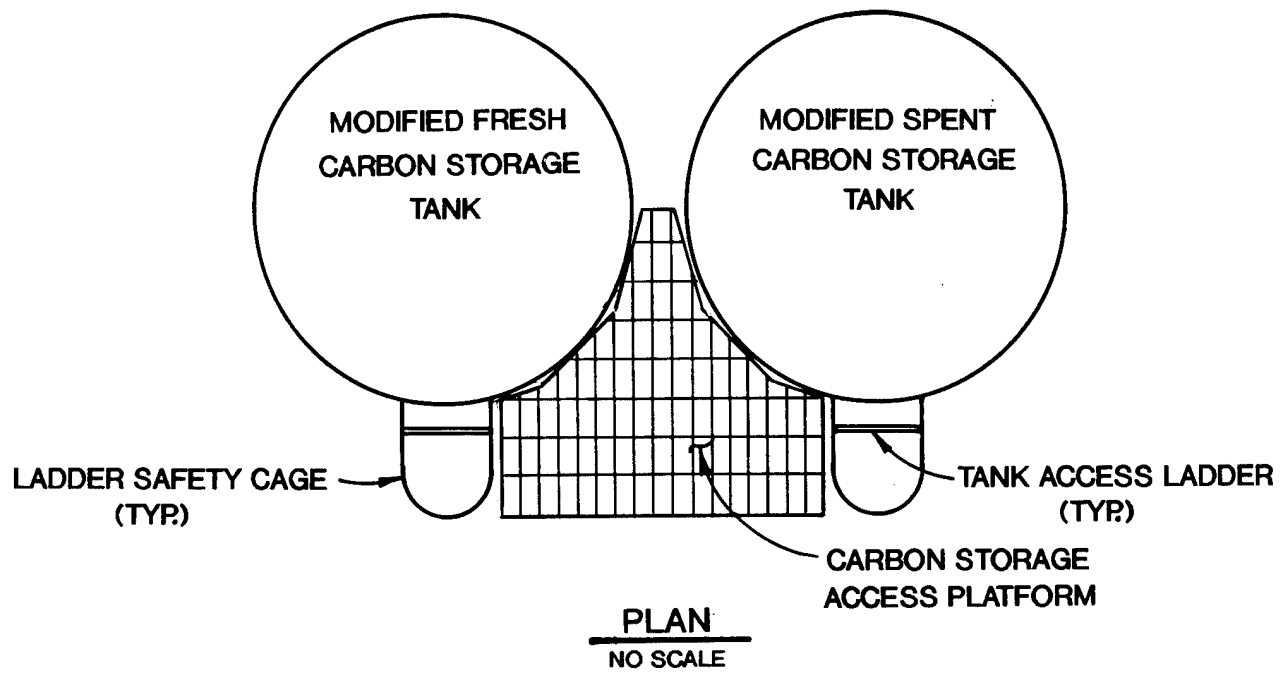

Rocky Mountain Arsenal

NORTH BOUNDARY SYSTEM IMPROVEMENTS IRA

FIGURE 10

CARBON STORAGE ACCESS PLATFORM



MK- ENVIRONMENTAL SERVICES
A DIVISION OF MK-FERGUSON

platforms. Each ladder is retrofitted with a cage and the platforms are equipped with safety railing.

3.5.3.10 It is planned to increase the overall height of the treatment building above the adsorbers and carbon storage tanks by a minimum of 6 feet to provide clearance for performance of operations and maintenance procedures. There currently exists only 1-2 feet of clearance above each of the vessels and storage tanks. The additional clearance provided by the 6-foot extension allows for the planned height increase of the carbon storage tanks and enables installation/ removal of the longer modified adsorber inlet septa screens.

Three options for increasing the height of the building were investigated as described below.

A. Under this option, an entire section of the existing building (including walls) is raised and supported on a new concrete wall constructed around the entire perimeter of the area to be modified. The electrical conduits, wiring and piping supported on the existing walls are disconnected at the base of the wall. Once the building is raised, the services are reconnected. The entire modification as described including modification of the existing building foundation is estimated to require in excess of 4 weeks to complete. Because power, control signals, and some process piping would be out of commission during this time, shutdown of the entire treatment plant is also required. Such a long shutdown period is unacceptable and this option was not further considered.

- B. Under this option, the height of the building above the adsorbers and storage tanks is increased through construction of a high bay as a separate structure from the existing building. Removal of the existing roof and replacement of a portion of the roof following construction of the high bay is required. Also required is modification of the existing concrete floor for support of the structural steel members of the high bay. Such a modification would entail removal of existing floor sections, manual excavation below the floor openings, and construction of concrete piers for support of the high bay structure.

Construction of the high bay superstructure interferes with the definer/blowcase skid and adsorber access catwalk located on the south side of the treatment building. Relocation of these structures is required which would be very disruptive to the operation of the treatment system. Since such disruptions cannot be tolerated, this alternative was not further considered.

- C. Under this option, the entire roof is raised intact and resupported on extensions to the steel support columns of the existing building. Preliminary calculations indicate the existing foundation to be adequate for the increased loading planned under this modification. Modification is required of the existing steel support columns at the base to account for additional wind loading. Otherwise, this option is relatively easy to implement and would be least disruptive to treatment plant operations when compared to the other alternatives. This option

is therefore selected for implementation in this IRA. The planned modifications were conceptually reviewed by Denver Commercial Builders who performed preliminary design calculations to establish its feasibility. They also provided a budgetary price quotation for performance of the work.

- 3.5.3.11 It is planned to modify the existing definer/blowcases and their operation for more effective defining of virgin carbon. Current operation involves backwashing of the carbon for 30-40 gpm at a flowrate of approximately 40 gpm. It is evident from observation of the backwash wastewater that the current methodology does not remove sufficient quantities of fines from the virgin carbon.

Backwashing at a higher flowrate is required to effectively define carbon. The primary objective is to achieve a 50 percent bed expansion which requires backwashing at a minimum flowrate of 170 gpm. The equivalent hydraulic loading at this flowrate is approximately 13.5 gpm/ft². The current backwash rate of 40 gpm (3.2 gpm/ft²) does not provide any bed expansion and, consequently, is ineffective in removal of fines. It is anticipated that a backwash duration of only 15-20 minutes is required at the higher backwash flowrate. The backwash water is supplied by the planned utility water pump located in the clarifier effluent sump.

In order to provide 50 percent bed expansion of a single carbon load of 2000 pounds (@ 28 lb/ft³), it is necessary to add 3.5 feet to the straight side height of the existing stainless steel vessel. Conceptually, the cylindrical portion of the vessel is cut and a new

cylindrical section is then welded to the vessel to increase its height. Cutting and modification of the vessel requires recertification as an ASME code vessel.

The spent carbon blowcase is currently not being used for its intended purpose which is to measure the volume of pulsed spent carbon prior to transfer into the spent carbon storage tank. This volume would then be matched by the virgin carbon makeup to the adsorber. It is planned to modify the spent carbon blowcase similar to the virgin carbon definer/blowcase to provide two units for defining and transporting virgin carbon. Virgin carbon makeup operations can be expedited through the use of two definer/blowcases. For instance, one unit can be receiving or sending carbon while the second unit is undergoing backwash.

3.5.3.12 It is planned to convert the existing wastewater sump for operation as a continuous flow clarifier. The sump currently operates as a batch sedimentation basin with decant being transferred to the influent sump following sedimentation. During carbon defining operations and loading of spent carbon onto tank trucks, the capacity of the sump is exceeded, resulting in pumping of decant to the influent sump without sufficient sedimentation. A significant amount of carbon fines are carried over into the influent sump in this manner. Conversion of the sump to a continuous flow clarifier allows for reuse of the clarified water as carbon defining and transport water. The end results are more effective removal of suspended solids, increase in wastewater handling capacity, and decrease in process water usage. A simplified process flow diagram contained in Figure 11 shows the function of the wastewater sump during critical operations involving carbon defining and spent carbon loading.

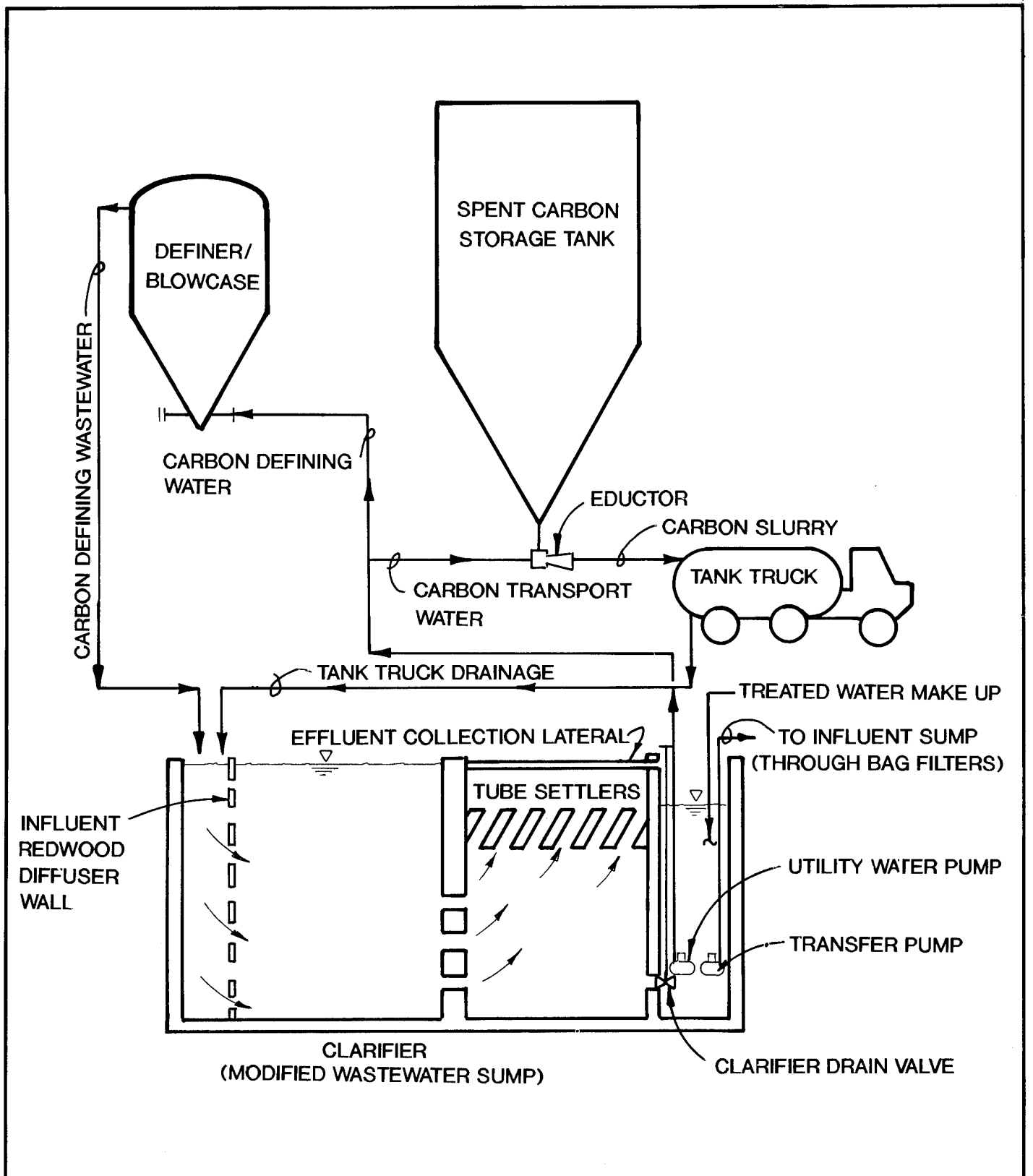

Rocky Mountain Arsenal
 NORTH BOUNDARY SYSTEM IMPROVEMENTS I&A
 FIGURE 11
 CARBON WASTEWATER HANDLING SCHEMATIC

MK-ENVIRONMENTAL SERVICES
 A DIVISION OF MK-FERGUSON

As shown, provision is included for addition of treated water to the clarifier effluent sump. This source of makeup to the clarifier is used in the event the clarifier water is determined to be substantially contaminated with organic compounds. Under these conditions, contamination of virgin carbon is prevented by providing treated water make-up to the clarifier for use in defining virgin carbon. The process of using treated water for makeup to the clarifier begins by draining and pumping the clarifier contents to the influent sump. Treated water is then added to the clarifier effluent sump at a flowrate equal to the anticipated usage rate. The backwash wastewater is discharged to the clarifier for removal of suspended solids. Once the clarifier is full, the clarified effluent is reused for defining and treated water makeup to the influent sump is terminated.

Conversion of the existing sump to a continuous flow clarifier requires the following modifications. A plan and section of the modified sump are shown in Figure 12.

- A. A concrete wall is installed along the length of the tank to provide a new U-shaped basin greater than 40 feet in length.
- B. Openings are provided in the existing center dividing wall to allow for continuous flow through the newly created U-shaped basin. One half of the wall is modified with openings for operation as a diffuser wall. The other half of the wall is modified with openings for operation as a baffle wall.

NOTES:

1. FIRST SECTION OF TUBE SETTLERS ARE REMOVABLE TO FACILITATE BASIN CLEANING .
2. SHADED AREAS DENOTE ADDED WALLS.
3. UTILITY WATER AND TRANSFER PUMPS LOCATED IN THE EFFLUENT SUMP NOT SHOWN FOR CLARITY.
4. ALL DIMENSIONS OF EXISTING SUMP ARE APPROXIMATE AND REQUIRE FIELD VERIFICATION.

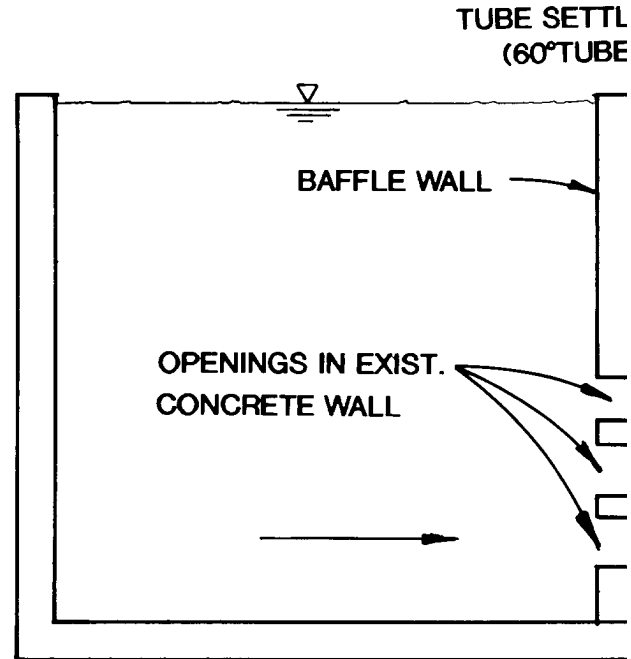

SECTION
SCALE = 1/4"

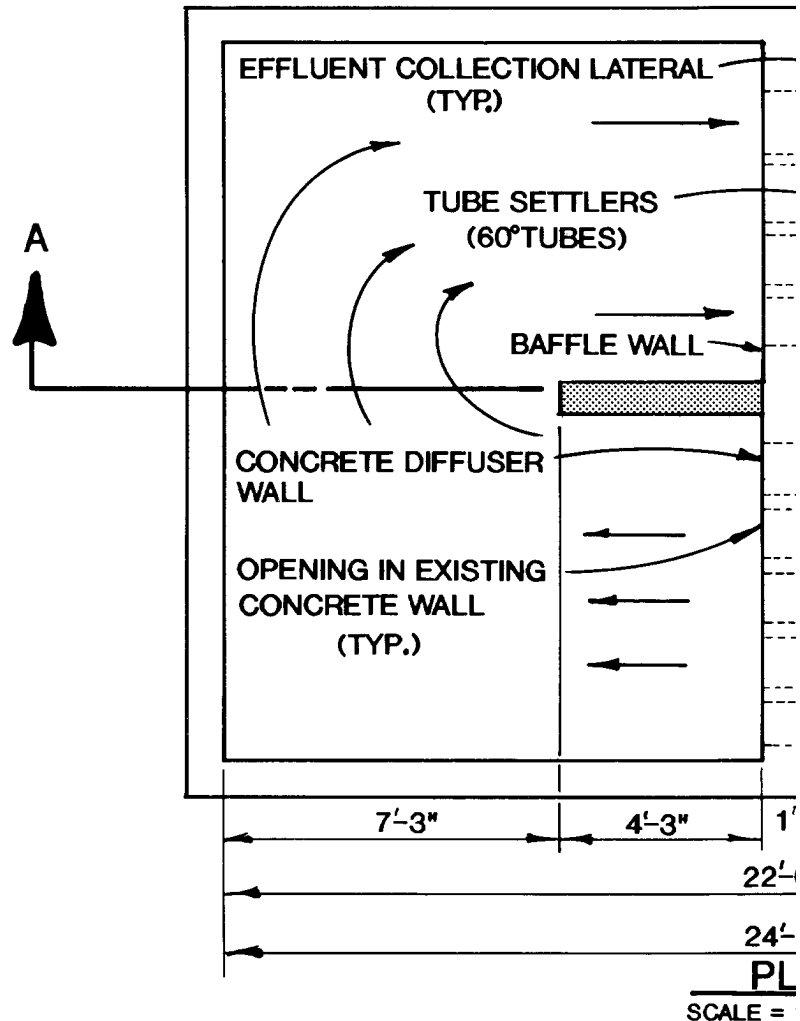

PL
SCALE = 1/4"

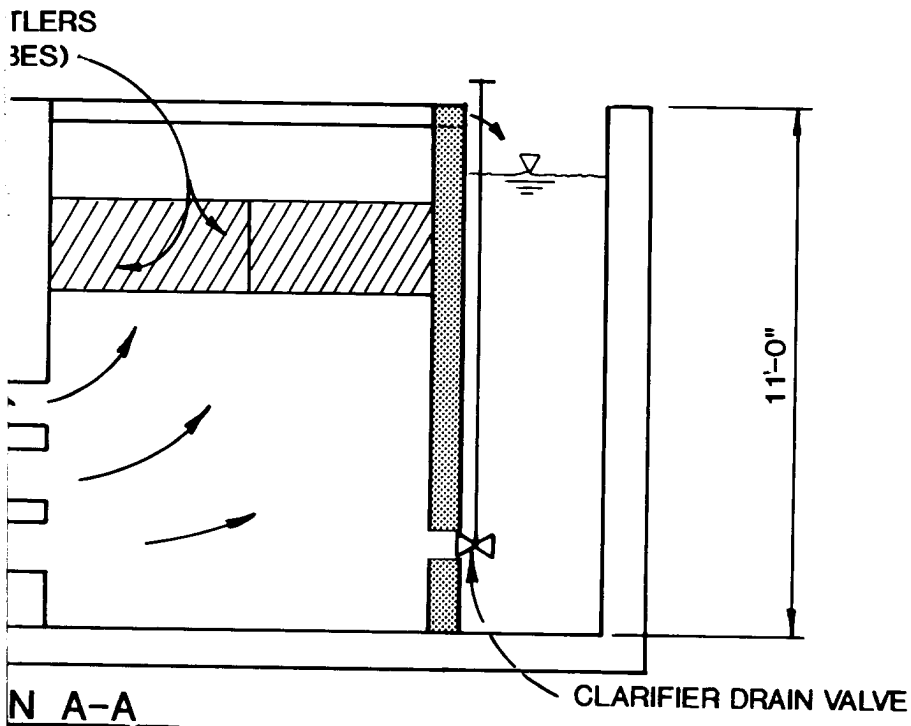

N A-A
 1/4"=1'-0"

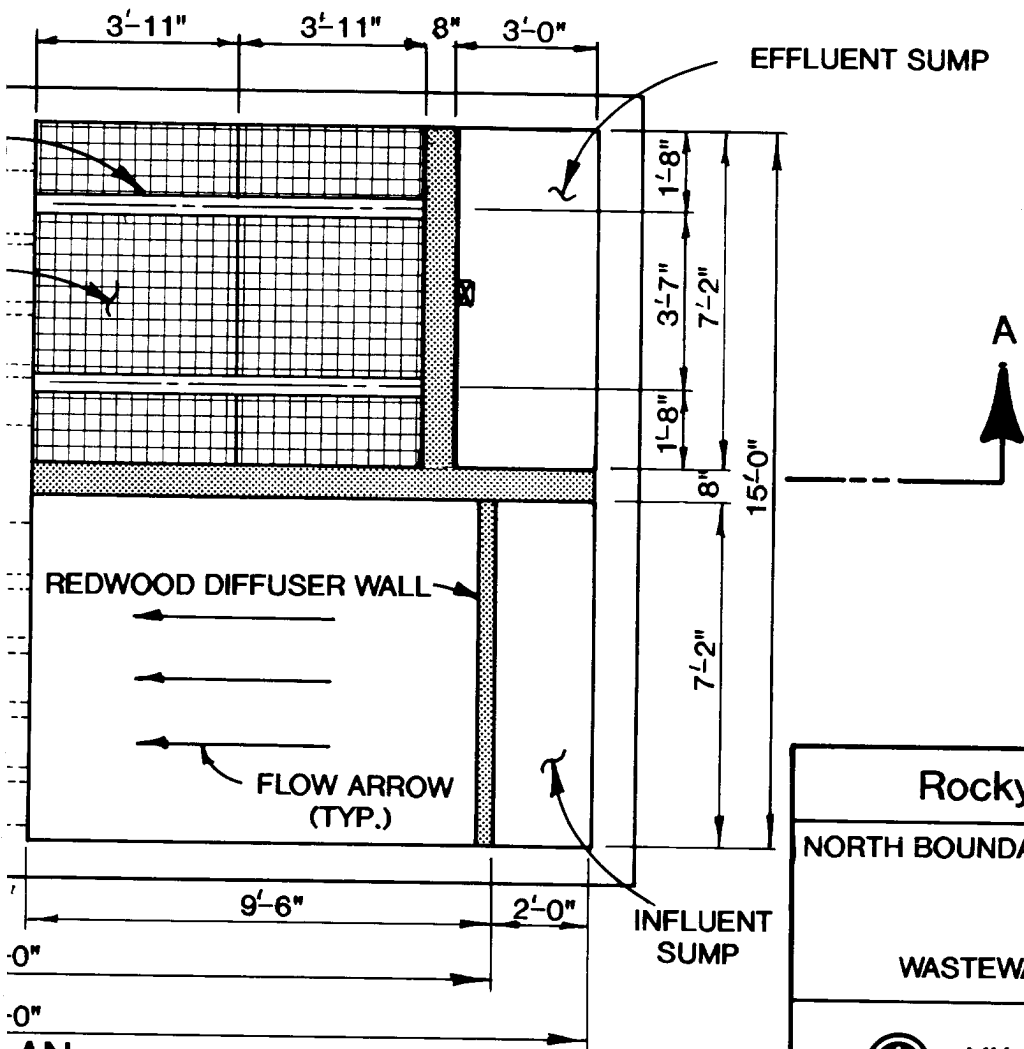

AN
 1/4"=1'-0"

Rocky Mountain Arsenal
NORTH BOUNDARY SYSTEM IMPROVEMENTS IRA
FIGURE 12
WASTEWATER SUMP MODIFICATIONS
 MK-ENVIRONMENTAL SERVICES A DIVISION OF MK-FERGUSON

- C. An influent sump is created at one end of the U-shaped basin through construction of a redwood diffuser wall. Influent wastewater from the treatment process is discharged to this sump.
- D. An effluent sump is created at one end of the U-shaped basin through construction of a concrete wall. The sump provides surge capacity for pumping of clarified water. A wall thimble with drain valve is provided in the concrete wall for draining of the clarifier. The drain valve is located such that the settled solids are not disturbed during draining operations.
- E. Tube settlers are installed upstream of the effluent sump for improvement of sedimentation.
- F. Effluent collection laterals are installed above the tube settler area for collection of clarified water. The laterals aid sedimentation efficiency by providing even distribution of flow across the tube settlers.
- G. Two pumps are installed in the effluent sump for pumping of clarified water. One larger utility water pump supplies water for carbon defining and spent carbon loading operations. The second and smaller transfer pump is utilized for pumping of clarified water from the clarifier to the influent sump.

The modified sump was evaluated based on typical design criteria for sedimentation basins such as hydraulic surface loading (gpm/ft²), mean horizontal velocity (ft/min), detention time (min), and weir loading

(gpm/ft). All calculated values at highest anticipated flows satisfied or exceeded the design criteria.

3.5.3.13 It is planned to add a bag filtration system to the clarified water discharge line from the clarifier to the influent sump as a safeguard against excessive carryover of suspended solids into the plant influent. As shown in Figure 7, the filtration system consists of two bag filters operating in parallel. The filter housing and bags are sized to provide sufficient filter run time for handling a minimum of one clarifier volume. This sizing criteria allows for manual transfer of feed from the operating filter to the standby filter.

The filters are initially equipped with 10-micron filter bags. Operational experience may dictate use of filter bags with lower micron ratings for increased particle removal efficiency.

3.5.3.14 It is planned to provide piping modifications for discharging of adsorber effluent to waste after loading of virgin carbon into an adsorber. This serves to prevent carryover into the effluent sump of carbon fines generated during virgin carbon defining and transfer operations. The end result is a substantial decrease in loading on the post-filtration system. Utilizing this modification, the adsorber effluent is first discharged to the spent carbon storage tank for a preset length of time. The adsorber effluent is then routed for recharge to the effluent sump. The planned routing of adsorber effluent to waste is shown on Figure 8.

The "discharge-to-waste" adsorber effluent is temporarily stored in the spent carbon storage tank and

discharged at a controlled and relatively low flowrate to the clarifier. In this fashion, the spent carbon bed provides gross filtration for removal of the majority of the suspended solids.

3.5.3.15 It is planned to replace all short radius elbows in virgin carbon transfer piping with long radius elbows. A major portion of the carbon fines produced during carbon transfer operations is generated at bends. Any improvements to the flow geometry at these bends will substantially reduce the amount of fines generated during carbon transfer operations.

3.5.3.16 It is planned to replace the existing adsorber manway covers in the top head of each vessel with the quick opening type of covers. This modification facilitates easy access to the interior of the vessel necessary for observation of carbon bed levels during carbon transfer operations. Current "blind" operation involves transferring of make-up virgin carbon to the adsorber until the carbon transfer piping is plugged, indicating a full adsorber. The plugged line is then backflushed and the purged carbon is discharged to the wastewater sump. Such a mode of operation cannot completely fill the adsorber and introduces a substantial amount of granular carbon to the wastewater sump.

Addition of quick opening manway covers allows for implementation of different operating procedures for carbon addition to a pulsed adsorber. Under the suggested procedure, an operator can continuously observe and level the carbon bed during transfer operations. Once the adsorber is full, a signal is given to a second operator to stop the transfer. The

adsorber can now be filled to the maximum level possible without discharge of carbon to the clarifier (modified existing wastewater sump).

3.5.3.17 It is planned to add a carbon tank truck loading and unloading station for containing leakage and spills of potentially contaminated water during carbon transfer operations. The station is located west of the treatment building where current loading and unloading operations are performed.

The loading and unloading station consists of a curbed concrete pad approximately 10 feet wide by 30 feet long. The pad is sloped to a center trench drain which collects leakage or spillage from the tank trucks. The trench drain discharges into an underground drain line which conveys the wastewater to the clarifier for treatment. Waterstops are provided in all concrete joints to form a hydraulic retention area.

3.5.3.18 It is planned to add a flexible hose to the end of the carbon inlet line of the spent carbon storage tank. The flexible hose is manipulated during carbon transfer operations for leveling of the carbon bed. In this manner, elevation changes of the carbon bed are more easily and accurately determined.

3.5.4 Treatment Plant Operational Improvements

Improvements to the NBS are accomplished mostly through proper operation of the treatment system modifications as previously planned in the report. However, certain operational improvements have been identified during the evaluation of the existing treatment plant. Implementation of such operational changes within the plant will improve the efficiency and reliability of treatment, especially with regard to carbon

usage, filter changeout, and carbon fines removal. These suggested operational procedures are detailed below.

3.5.4.1 It is suggested to perform pilot carbon column testing of the combined groundwater from the three extraction manifolds. The pilot testing will be performed using the Accelerated Column Test as provided by Calgon Corporation. Pilot testing predicts more accurately the expected carbon usage rate, and is recommended over isotherm testing which only predicts theoretical carbon usage, or ballpark estimate for 100% removal of the contaminant of concern. The Accelerated Column Test is unique in that small sample volumes and short testing times are required to produce usable results. The results from this testing method have compared very favorably with the results obtained through parallel testing using larger scale pilot testing units.

The expected carbon usage rate thus obtained is critical for determination of carbon pulse schedules and monitoring of adsorber performance.

3.5.4.2 It is suggested to perform periodic depth sampling of the adsorber water for establishment of horizontal contaminant profile across the bed. The middle sample port located approximate 5 feet from the bottom of the vessel straight side height is utilized for this purpose. The suggested horizontal sampling depths into the bed are 2 and 5 feet. The 5-foot sample gives indication of the contaminant loading at the center of the bed while the 2-foot sample gives indication of contaminant loading near the perimeter of the bed.

Establishing horizontal contaminant profile is useful in determining possible short-circuiting within the bed

and the need for adjustment of flowrates to improve flow distribution.

- 3.5.4.3 It is suggested to perform, as a minimum, annual inspections and/or cleaning of the inlet and outlet screens of each adsorber. The procedure is a preventative measure against excessive plugging of the screens by solids or scale buildup and is critical to maintaining even flow distribution across the carbon bed.
- 3.5.4.4 It is suggested to perform, as a minimum, annual cleaning of the influent lines to the pre-filters and adsorbers for prevention of excessive solids and/or scale buildup on piping internals. The cleaning is accomplished through pigging of the lines.
- 3.5.4.5 It is suggested to calibrate instrumentation at least every 6 months to maintain accuracy of operating data collected for plant control. The instrumentation requiring calibration would include flow meters, flow indicator/totalizers, level probes, level indicator/controllers, level switches, and pressure gages.
- 3.5.4.6 It is suggested to perform periodic cleaning of the clarifier for control of solids buildup within the basin. This procedure ensures that solids carryover into the influent sump is minimized during clarifier draining operations.
- 3.5.4.7 As previously discussed in the report, it is recommended to "top off" the adsorber during each carbon addition cycle to reduce carryover of small carbon particles into the adsorber effluent, to reduce adsorber headloss, and to improve flow distribution

amongst the outlet screens. Filling the adsorber to the maximum extent possible with carbon provides for complete submergence of the outlet septa well screen. As a result, the carbon bed acts as a filter to prevent smaller carbon particles from migrating toward the screens.

4.0 PROJECT COST ESTIMATE

The budgetary project cost estimate summary for the North Boundary System Improvements IRA is presented in Table 1. The mobilization and demobilization costs are included in the subtotals for each construction cost item. Costs for constructing new dewatering facilities or abandoning any wells (as discussed in Section 3.2 and 3.3, respectively) are not included. A 25 percent contingency and fee allowance has been included in the total estimated project cost of \$1,895,000.

NORTH BOUNDARY IMPROVEMENTS IRA
TABLE 1 - BUDGETARY PROJECT COST ESTIMATE SUMMARY

COST ITEM -----	COST (\$) -----
Working Bench Excavation/Backfill	35,000
Recharge Trenches	135,000
Yard Piping/Electrical	115,000
Observation Wells	138,000
Treatment Plant Modifications	
Carbon Storage Tank Modification	32,000
Post-Filter Replacement	29,000
Adsorber Access Manway Cover Replacement	6,000
Definer/Blowcase Modification	30,000
Elevated Platform/Safety Railing/Ladder Cage Addition	31,000
Pre-Filter Replacement	22,000
Pre-Filter/Adsorber Influent Piping Improvements	38,000
Treatment Building Modification	57,000
Wastewater Bag Filter Addition	10,000
"Treat-to-Waste" Piping Modification	9,000
Wastewater Sump Modification	39,000
Adsorber Inlet/Outlet Septa Replacement	18,000
Influent Sump Modification	12,000
Truck Loading/Unloading Station Addition	16,000
Miscellaneous Piping Modifications	20,000
Instrumentation/Control Modifications	61,000
Final Engineering Design	205,000
Supervision/General Expense/Overheads/Health & Safety	320,000
General Administration (10%)	138,000
Contingency & Fee (25%)	379,000

Total Estimated Cost	1,895,000