

AD \_\_\_\_\_

GRANT NO: DAMD17-94-J-4428

DICOM/ATM DEMONSTRATION FOR RSNA '94  
TITLE: A DICOM/ASYNCHRONOUS TRANSFER MODE (ATM) INTERFACE ALLOWING OPEN ACCESS  
TO MDIS AND OTHER PACS

PRINCIPAL INVESTIGATOR: Fred W. Prior, Ph.D.

CONTRACTING ORGANIZATION: Pennsylvania State University  
Hershey Medical Center  
Hershey, Pennsylvania 17033

REPORT DATE: 1/30/95

TYPE OF REPORT: Final

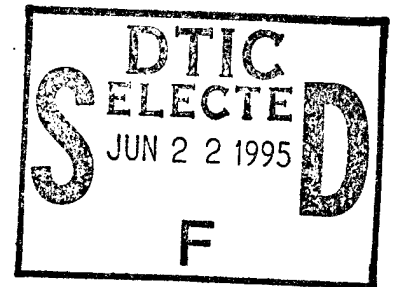

PREPARED FOR: U.S. Army Medical Research and Materiel Command  
Fort Detrick, Maryland 21702-5012

DISTRIBUTION STATEMENT: Approved for public release;  
distribution unlimited

The views, opinions and/or findings contained in this report are those of the author(s) and should not be construed as an official Department of the Army position, policy or decision unless so designated by other documentation.

19950620 058

Encl 1

# DISCLAIMER NOTICE

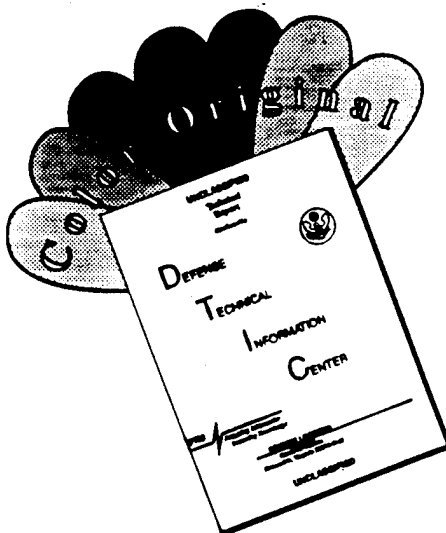

THIS DOCUMENT IS BEST QUALITY AVAILABLE. THE COPY FURNISHED TO DTIC CONTAINED A SIGNIFICANT NUMBER OF COLOR PAGES WHICH DO NOT REPRODUCE LEGIBLY ON BLACK AND WHITE MICROFICHE.

# REPORT DOCUMENTATION PAGE

Form Approved  
OMB No. 0704-0188

Public reporting burden for this collection of information is estimated to average 1 hour per response, including the time for reviewing instructions, searching existing data sources, gathering and maintaining the data needed, and completing and reviewing the collection of information. Send comments regarding this burden estimate or any other aspect of this collection of information, including suggestions for reducing this burden, to Washington Headquarters Services, Directorate for Information Operations and Reports, 1215 Jefferson Davis Highway, Suite 1204, Arlington, VA 22202-4302, and to the Office of Management and Budget, Paperwork Reduction Project (0704-0188), Washington, DC 20503.

<b>1. AGENCY USE ONLY (Leave blank)</b>	<b>2. REPORT DATE</b> 1/30/95	<b>3. REPORT TYPE AND DATES COVERED FINAL</b> July 15, 1994 through Dec. 31, 1994	
<b>4. TITLE AND SUBTITLE</b> DICOM/ATM DEMONSTRATION FOR RSNA '94 A DICOM/ASYNCHRONOUS TRANSFER MODE (ATM) INTERFACE ALLOWING OPEN ACCESS TO MDIS AND OTHER PACS		<b>5. FUNDING NUMBERS</b> DAMD17-94-J-4428	
<b>6. AUTHOR(S)</b> Fred W. Prior, Ph.D.			
<b>7. PERFORMING ORGANIZATION NAME(S) AND ADDRESS(ES)</b> Penn State College of Medicine Dept. of Radiology 500 University Dr. Hershey, PA 17033		<b>8. PERFORMING ORGANIZATION REPORT NUMBER</b>  1995-A1	
<b>9. SPONSORING / MONITORING AGENCY NAME(S) AND ADDRESS(ES)</b> U.S. Army Medical Research and Materiel Command Fort Detrick, Maryland 21702-5012		<b>10. SPONSORING / MONITORING AGENCY REPORT NUMBER</b>	
<b>11. SUPPLEMENTARY NOTES</b>			
<b>12a. DISTRIBUTION / AVAILABILITY STATEMENT</b>  Approved for public release; distribution unlimited		<b>12b. DISTRIBUTION CODE</b>	
<b>13. ABSTRACT (Maximum 200 words)</b> As large scale PACS becomes reality the question of linking hospital systems into regional HyperPACS arises. Two key prerequisites for such systems are high network throughput and open interfaces to permit integration of heterogeneous systems. The combination of DICOM and ATM meet these two key requirements.  We have developed a demonstration DICOM/ATM gateway for the MDIS System PACS which functions as a DICOM Query/Retrieve service provider supporting an external workstation connected via ATM to allow access of patient information and imagery. Physicians dialing in from different sites will demonstrate this "open system" workstation featuring teleconferencing capability and a "radiology window" to display and manipulate medical images simulating a HyperPACS scenario.  <p style="text-align: right;">DICO QUALITY INSPECTED 3</p>			
<b>14. SUBJECT TERMS</b>  MDIS DICOM ATM Telemedicine			<b>15. NUMBER OF PAGES</b> 33
			<b>16. PRICE CODE</b>
<b>17. SECURITY CLASSIFICATION OF REPORT</b> Unclassified	<b>18. SECURITY CLASSIFICATION OF THIS PAGE</b> Unclassified	<b>19. SECURITY CLASSIFICATION OF ABSTRACT</b> Unclassified	<b>20. LIMITATION OF ABSTRACT</b> Unlimited

FOREWORD

Opinions, interpretations, conclusions and recommendations are those of the author and are not necessarily endorsed by the US Army.

Where copyrighted material is quoted, permission has been obtained to use such material.

Where material from documents designated for limited distribution is quoted, permission has been obtained to use the material.

XX Citations of commercial organizations and trade names in this report do not constitute an official Department of Army endorsement or approval of the products or services of these organizations.

In conducting research using animals, the investigator(s) adhered to the "Guide for the Care and Use of Laboratory Animals," prepared by the Committee on Care and Use of Laboratory Animals of the Institute of Laboratory Resources, National Research Council (NIH Publication No. 86-23, Revised 1985).

For the protection of human subjects, the investigator(s) adhered to policies of applicable Federal Law 45 CFR 46.

In conducting research utilizing recombinant DNA technology, the investigator(s) adhered to current guidelines promulgated by the National Institutes of Health.

In the conduct of research utilizing recombinant DNA, the investigator(s) adhered to the NIH Guidelines for Research Involving Recombinant DNA Molecules.

In the conduct of research involving hazardous organisms, the investigator(s) adhered to the CDC-NIH Guide for Biosafety in Microbiological and Biomedical Laboratories.

Accession For	
NTIS CRA&I	<input checked="" type="checkbox"/>
DTIC TAB	<input type="checkbox"/>
Unannounced	<input type="checkbox"/>
Justification	
By	
Distribution /	
Availability Codes	
Dist	Avail and/or Special
A-1	

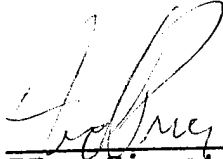
  
PI - Signature      1/30/95  
Date

## TABLE OF CONTENTS

INTRODUCTION .....	1
Background.....	2
Project Goals.....	5
Key Technologies.....	6
BODY.....	6
Methods.....	6
Network.....	7
Workstation.....	8
Gateway.....	10
Results.....	11
Network Performance.....	13
Discussion.....	15
CONCLUSIONS .....	16
REFERENCES .....	18

**A DICOM/ASYNCHRONOUS TRANSFER MODE (ATM)**  
**INTERFACE ALLOWING OPEN ACCESS TO MDIS AND OTHER**  
**PACS**

**Demonstration of ATM/Open Systems  
Telemedicine at RSNA '94**

**INTRODUCTION**

At the 1994 meeting of the Radiological Society of North America (RSNA) in Chicago, a team of engineers, computer scientists and radiologists from academia, the military and industry, assembled by the US Army's Medical Diagnostic Imaging Support Program Office (MDIS PMO) demonstrated an integrated telemedicine system.

A workstation developed by the Section of Radiologic Computing and Imaging Science at Penn State used the Digital Imaging and Communications in Medicine (DICOM) standard to search databases of medical information and retrieve medical images from multiple MDIS systems. A DICOM gateway developed by Loral Medical Imaging Systems, prime contractor for the MDIS program, facilitates this open interface. The Penn State workstation also incorporates state of the art video teleconferencing capabilities that can transmit and receive audio and video at the same time full resolution medical images are being retrieved. A coast-to-coast Asynchronous Transfer Mode (ATM) high speed network provided by Sprint, linked the gateways and workstations at sites in California and Maryland to the RSNA conference site in Chicago.

At the 1993 annual meeting of the Radiological Society of North America, the MDIS PMO successfully demonstrated the use of MDIS teleradiology technology in a clinical setting, with emphasis on its potential for saving lives on the battlefield and in natural and man-made disasters. This demonstration was supported in various ways by Loral Corporation, Siemens Gammasonics Corporation (SGI), U.S. Sprint Corporation (Sprint), Compression Labs, Inc., Fuji Medical Systems, Inc. and other commercial concerns. The demonstration was highly successful, drawing a huge crowd and, via connectivity to and/or demonstration of vended equipment and capabilities, was judged to be successful for the participating vendors as well.

The RSNA also provided, in its InfoRAD technical exhibit area, a demonstration of Digital Imaging Communications in Medicine (DICOM) (Horii, et al., 1993) connectivity involving a multitude of vendors (Hindel, 1994). This was intended to promote the new DICOM standard and, if participation and interest is the measure of success, this too was highly successful.

The MDIS PMO was requested by the RSNA to provide a new demonstration at InfoRAD, RSNA 1994. The RSNA, MDIS PMO and other parties are particularly interested in the demonstration of Asynchronous Transfer Mode technology (De Prycker, et al., 1993) and its utility in the areas of teleradiology and telemedicine. Provision of "open systems" connectivity in a clinical setting, based on DICOM, is also of great interest, as the natural follow-on to the InfoRAD '93 DICOM demonstration.

The Section of Radiologic Computing and Imaging Science at Pennsylvania State University College of Medicine (PSU), in collaboration with the MDIS PMO, Walter Reed Army Medical Center, and Loral Medical Imaging Systems submitted an abstract for a scientific exhibit at InfoRAD '94. In addition, the MDIS PMO arranged with the RSNA for a space in the InfoRAD area in which a hospital tent was erected. The tent housed both the PSU scientific exhibit and an MDIS teleradiology spoke system.

## **Background**

The U.S. Military has been a driving force in the development of medical Picture Archive and Communication Systems (PACS), teleradiology and most recently telemedicine. The military has unique logistic problems in battle field conditions that make digital technology attractive (Nadel et al., 1989). This technology also allows the military to leverage their radiology staff to the greatest possible extent.

Starting in 1978, the military has supported a number of studies to explore PACS technology. Teleradiology was an early and persistent interest. In 1978 the Navy conducted the first teleradiology field trial for Ship-to-Shore image transmission. This was followed by several additional field trials sponsored by the Army and the U.S. Public Health Service (Curtis et al., 1983). The results of all trials were encouraging. Because of the military's primary role, communication from remote sites to medical facilities

in secure areas is vitally important. As appropriate technologies have evolved, the U.S. Military Medical R&D command has attempted to keep pace and to encourage PACS related development.

In 1990 the Army and Air Force initiated an RFP (Request For Proposal) for a program to install fully digital hospitals at military medical treatment facilities around the world (Goeringer, 1990). This program is referred to as the Medical Diagnostic Imaging Support program, or MDIS. The contract was awarded in 1991 to a team of corporations lead jointly by Loral Western Development Laboratories and Siemens (Glicksman, et al., 1992). The MDIS program is the first serious attempt to actually field fully digital hospital-wide PACS and wide scale teleradiology.

Medical image communication over wide area networks is commonly referred to as teleradiology. Teleradiology systems cover a wide range of technologies and applications, from simple, low cost systems for the radiologist's home to high bandwidth links between two PACS installations (Gitlin, 1986).

Kuduvalli et al. (1991) provide an excellent historical review of teleradiology from the early attempts at analog transmission over voice grade lines, to T1 rate transmission of high resolution (4K x 4K) compressed digital images via both land lines and satellites. This same article also presents the requirements for wide area communication of plane film radiographs and reviews appropriate compression algorithms.

Mun (1992) described what is perhaps the most extensive teleradiology project ever proposed; interconnecting all US Military medical installations in Korea. The project linked 14 community and field hospitals to 2 hub sites for primary reading. These hubs in turn are linked to a primary Hub in Seoul. The Seoul facility will be linked to Tripler Army Hospital in Hawaii via satellite for overread services. The Korea project is the first step in an overall plan by the U.S. military to interconnect all PACS equipped medical treatment facilities via T1 rate land lines and 56 Kbps (INMARSAT) satellite links.

Telemedicine expands beyond the image communication systems of teleradiology to encompass n-way video teleconferencing and remote physical examinations (Goeringer and Leckie, 1994). To date, telemedicine projects have focused on relatively low bandwidth

communication channels and COTS video conference technology. To move to true multi-media telecommunication (high resolution radiology images, video, audio, graphics, etc.) requires higher bandwidth communication technology (Wilson, et al., 1995).

The National Information Infrastructure (NII) is a broad ranging government initiative with the goal of creating "a seamless web of communications networks, computers, databases and consumer electronics that will put vast amounts of information at user's fingertips." (National Information Infrastructure, 1993) The NII consists of the public and private networks that support communications between computers in the United States.

To understand high speed wide area networks several national testbeds have been established around the country. There seems to be a growing consensus that a future Internet must be based on a protocol that can support gigabit speeds. The technology of choice underlying the current testbed trials is Asynchronous Transfer Mode (ATM).

ATM is a revolutionary approach to computer networking since it offers an integrated solution for both local and wide area connectivity. Private local area ATM switches provide local connectivity and can substitute currently existing local area networks (LANs). Wide area connectivity is achieved by ATM services offered by public carriers. Thus, ATM can provide an end-to-end solution for data transport which does not require time-consuming and inefficient protocol conversions.

The functionality of ATM corresponds to the lower two layers of the OSI reference model, the data link layer and the physical layer. All traffic in ATM networks is transmitted in fixed sized packets, called cells. The data rates supported by ATM are the transmission speeds supported by the SONET transmission schemes, i.e., OC-1 at 51.84 Mbps, OC-3 at 155.52 Mbps, and OC-12 at 622.08 Mbps.

Equally important as high speed, the National Information Infrastructure requires an open systems architecture. In order for there to be an interchange between any two users there must be a standard for connectivity, and a standard for the interchange between applications on two separate systems. The utilization of the

NII requires an "OPEN" connection which will let two dissimilar systems communicate effectively.

An open system in the narrow sense requires a software platform that is widely supported and hardware independent. An open system is based on standards that are widely accepted and for which software is readily available from multiple sources. In the broader sense an open system is a set of services with standard interfaces distributed on a network and sharing common communication facilities.

The NII depends on global consensus on appropriate standards. It is vital that medical image and information service components of the NII be carefully defined. The DICOM standard has been shown to be a key component of a global medical communication strategy. It is one of several complimentary standards that will be required for global open systems. DICOM, running on an appropriate high speed communication protocol like ATM, is the best way to integrate high volume medical data into the NII (Prior, et al., 1995).

### **Project Goals**

The MDIS program has fielded several large-scale PACS (Smith, et al., 1994). A key consideration for those planning the NII is the question of how to incorporate existing (or legacy) systems such as MDIS. It is incumbent upon the MDIS PMO and their collaborators to demonstrate that MDIS systems can, indeed, support a standard, open interface to an ATM WAN.

The project reported here demonstrated coast-to-coast connectivity of multiple MDIS systems using DICOM standard image retrieval over an ATM network. In addition to this "open" access to MDIS systems for radiology image retrieval, video teleconferencing and patient vital signs monitoring applications simultaneously supported telemedicine functions over the same network. The project explored the integration of Teleradiology and Telemedicine functions in a single workstation.

We are not just demonstrating 'teleradiology' or 'telemedicine'. With ATM technology we can remotely treat the whole patient within clinically viable time frames. Using DICOM a physician can access radiology images and patient information from any

appropriately equipped PACS (Picture Archive and Communication System)

A key advantage of this technology will be to eliminate the need to move critically ill patients from small rural hospitals to major medical centers for specialty diagnostic procedures. Instead the specialists will be brought to the patient in real time. The ability to query and retrieve historical images from remote locations is an essential part of a clinically useful telemedicine system. The DICOM query/retrieve mechanism which provides this capability has received too little attention to date. Demonstrating this capability on MDIS sets the U.S. military ahead in the effort to create a clinically viable telemedicine system

### **Key Technologies**

Several novel technologies were developed in support of this project. All software developed by Penn State will be placed in the public domain to encourage and facilitate development of compatible systems by vendors and academic institutions.

In summary, the following technological advances were implemented and field tested.

- DICOM-TCP-ATM communication protocol in both LAN and WAN environments.
- DICOM Query/Retrieve Service Class User embedded in a Mosaic (Schatz and Hardin, 1994) Server.
- DICOM Services, Video Teleconferencing and Vital Signs monitoring over a common ATM infrastructure.
- Loral Medical Imaging Systems, Corp. in consultation with Penn State, developed an MDIS Gateway incorporating a DICOM Query/Retrieve Service Provider.
- DICOM Image Display Tools.

### **BODY**

#### **Methods**

As illustrated by Figure 1, an ATM network testbed was established between Frederick, MD, Chicago, IL, and San Mateo, CA for a three week period beginning November 14, 1994. This network,

which consisted of ATM LAN and WAN segments, was used to evaluate integrated teleradiology and telemedicine applications.

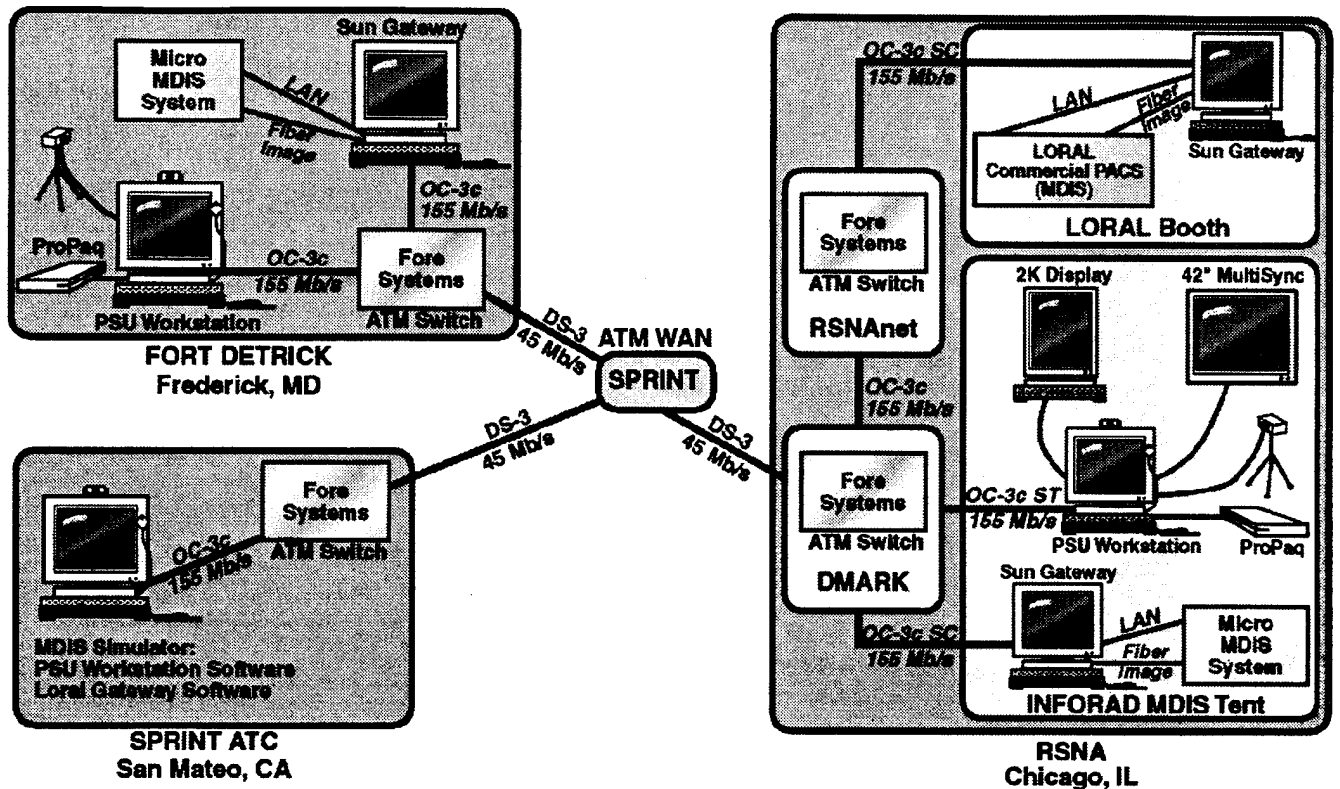

Figure 1. ATM WAN Testbed

## Network

An ATM LAN was established in the Section of Radiologic Computing and Imaging Science at Penn State. A Fore Systems ASX-100 switch (Fore Systems, Inc. Warrendale, PA) was connected to a Fore Systems ASX-200 switch by a DS3 rate (44.7360 Mbps) circuit. One Sun SparcStation 20/60 was attached via an OC-3 (155.25 Mbps) fiber circuit to each switch.

An ATM WAN was established between the Sprint Applied Technology Center in San Mateo, CA and the MDIS PMO at Ft. Detrick, Frederick, MD on November 14, 1994. A Bell Atlantic DS3 circuit connected Ft. Detrick to the local Sprint POP. A Sprint DS3 service was used to connect the two end points. The DS3 was routed through Sprint broad-band switches in Relay, MD and Realto, CA. A Fore Systems ASX-100 LAN switch was attached to the DS3 circuit at each terminus of the WAN. In San Mateo a Sun SparcStation 20/60 was

connected to the ASX-100 using a 140 Mbps TAXI interface card and a 60 m. segment of multi-mode optical fiber. Several other circuits shared the Sprint LAN switch. At Ft. Detrick, two Sun SparcStation 20/60 workstations (a PSU workstation and a Loral DICOM gateway) were connected to the ASX-100 via OC-3, fiber circuits. Both ASX-100s were attached to the internet via their ethernet ports and external router. Each switch was configured so that it could be accessed for maintenance and configuration using the internet.

The third node of the WAN was established on November 21, 1994 by connecting a third ASX-100 switch located in the McCormick Place conference center to an Ameritech DS3 circuit. The DS3 connected McCormick Place to the Sprint POP in downtown Chicago. From there a Sprint DS3 connected to the Sprint broad-band network through a third central office switch outside Chicago. OC-3 fiber runs connected the ASX-100 to two Sun SparcStation 20/60 workstations in the InfoRAD area of the RSNA (McCormick Place North Building) and one in the Loral Commercial Exhibit area (McCormick Place North Building, second floor).

The ATM WAN was interfaced to a Compression Laboratories (CLI) video conference terminal at Ft. Detrick to permit dial-up video conferences to be relayed to Chicago. The interface utilized a YEM CVS-980 (Yamashita Engineering Manufacturing Co., Japan) video scan converter to convert the high line rate video of the Sun workstation to standard NTSC. This signal was input to the CLI unit via the document camera port. The VCR output port of the CLI was attached to the video acquisition card in the Sun. Audio channels were similarly connected. The CLI was attached via a 56 Kbps INMARSAT uplink to a ground station in Haiti and by standard 56 Kbps land lines to various CONUS military facilities.

Performance measurements were made on both the ATM LAN and WAN segments (excluding the CLI interface) using the Netperf performance analysis package (Jones, 1995). This tool permitted socket to socket performance measurements to be gathered. DICOM performance was estimated via timing statistics output by the PSU workstation DICOM storage service provider (IS). DICOM estimates included disk storage times.

## **Workstation**

The Telemedicine Workstation developed by PSU is based on a dual processor Sun SparcStation 20/60 platform with 256 MB RAM and a 1 GB hard drive. An ATM adapter card (SBA-200, Fore Systems) and a high performance video frame grabber (Parallax) were added to the Sun chassis. A standard Sun color display was used for DICOM Query/Retrieve, teleconferencing, and vital signs monitoring applications. At the RSNA a second large screen (Mitsubishi 42" multisync ) color monitor was slaved to the Sun display to permit a larger audience to view the display. A high contrast resolution (10 bits per pixel) 1200 x 1600 pixel monochrome display (DataRay monitor, Dome Imaging display card) was used to display radiology images. All software applications were integrated on a single virtual desktop environment using Sun's OpenWindows virtual desktop manager. All workstations were also equipped with a video camera, microphone and speakers for teleconferencing.

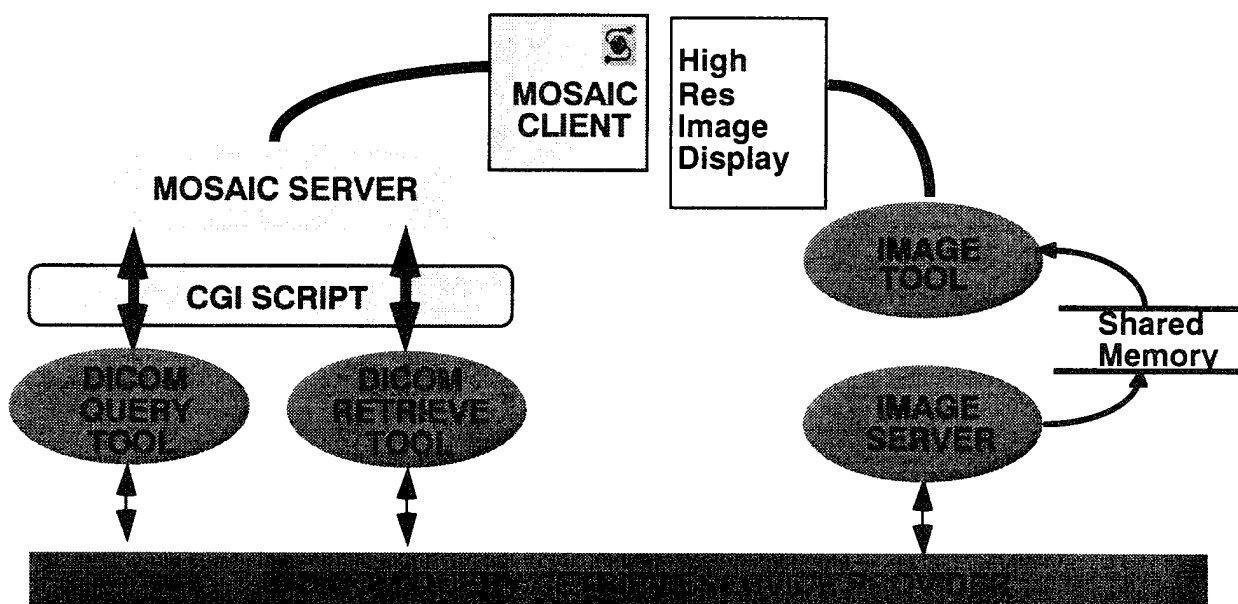

Figure 2. Telemedicine Workstation Software Architecture

Workstation Application Software was integrated as illustrated in Figure 2. An xmosaic client was used to provide the user interface for a DICOM query/retrieve service user, to provide information about the demonstration and for general World-Wide-Web access. Hypertext Markup Language (html) pages were generated "on-the-fly" by the DICOM Query Tool (QT) and DICOM Retrieve Tool (DR) applications. These pages were piped directly to the Mosaic server. CGI scripts (Luotonen, 1994) were used to couple the DR and QT applications to the Mosaic server.

Image Tool (IT) is a DICOM Image display program that automatically loads images on retrieval as well as supporting manual loading from local disk. All Image Tool functions were controlled by the three buttons on a mouse: the left button invoked the Window/Level function, the center button a Magnifying Glass function and the right button pops up a menu of additional functions. Menu functions included: N-up multi-image formatting, image cut, copy and paste, cine and stack views, image flip/rotate and place holders for future expansion.

Image Server (IS) is a multi-threaded, DICOM Storage Service Class provider. IS was designed to use shared memory to pass images directly to Image Tool. Unrequested images (i.e. image transfers not initiated by the local node using a DICOM Move operation) are written to disk as UNIX files. Basic transfer timing statistics were gathered and output to a temporary file.

In addition to the above software that was written specifically for the project by PSU, two key commercial applications were bundled into the PSU workstation. Communiqué (Insoft, Inc.) is a desk-top video teleconferencing tool that incorporates a shared digital whiteboard. Communiqué is designed to use the TCP-IP communication protocol and to interface to the Parallax video input card. Communiqué and the Parallax card provided input ports for a variety of telemedicine sensors: Otoscope, Ophthalmoscope, Dermatology camera, Stethoscope. In addition, the audio and video outputs of an Ultrasound imaging system (Acuson, Inc.) were attached via the Parallax card and Communiqué supported real-time Ultrasound procedures over the WAN.

For remote patient vital signs monitoring, a virtual Propaq (Protocol Systems, Inc.) was used. This device uses a X-windows based application to support real-time display of patient bio-signals (heart rate, blood pressure, ECG) acquired at a remote site.

## **Gateway**

Loral Medical Imaging Systems in conjunction with Penn State developed a demonstration/ATM gateway for MDIS as illustrated in Figure 3. This device acts as a Service Class Provider for a proper subset of the Query/Retrieve Service Class (Study Root Queries at the Study Level and retrieval via the C-Move operation at the Study

Level). The gateway supports message exchange using a TCP-IP communication profile that includes ATM. This gateway interfaces to the Loral image distribution system and information management system database.

An MDIS simulator was constructed by combining elements of the gateway software with the complete PSU workstation software package. A simulated MDIS database and image server were supported on local Sun disks. The simulator permitted remote PSU workstations to query it as if it were an MDIS system while at the same time permitting a local user to query remote MDIS systems and participate in video teleconferences.

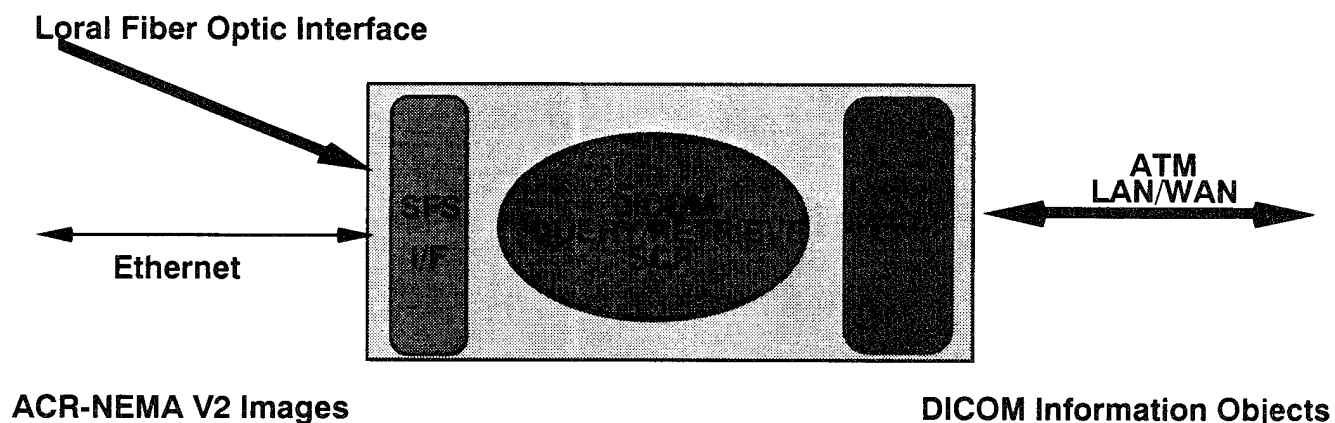

Figure 3. Query/Retrieve Gateway for MDIS

## Results

During the period from November 27 to December 2, 1994, continuous clinical demonstrations were performed at the Radiological Society of North America annual meeting in Chicago. A multi-part "clinical" scenario" was used:

- Select patients from Ft. Detrick clinic with digital images in the local MDIS system.
- Establish a teleconference link to InfoRAD and discuss the case with specialists.
- Transmit patient vital signs to InfoRAD in real time.
- Query the Ft. Detrick MDIS, retrieve full resolution images and display.
- Select images for discussion and interactively annotate in digital white board.

- Query and retrieve an old exam for comparison from another MDIS site.

This scenario permitted the entire repertoire of system functionality to be exercised.

Based on repeated operation of the clinical scenario the following observations were made.

- Full-motion teleconferencing was deemed significantly superior for telemedicine applications than the reduced frame rate of conventional teleconferencing systems.
- Image retrieval performance was acceptable but did not reach the expectations of the radiologist.
- Image display performance on the PSU workstation was not acceptable.
- Interactive image annotation was not of significant interest to most radiologists.
- Remote patient vital signs monitoring in conjunction with remote physical examination of the patient was considered a significant breakthrough.

The ability to perform remote, real-time Ultrasound examinations permitted the project team to gain initial experience with both telepresence ultrasound examinations and telementoring. On more than 10 occasions, a radiologist in Chicago successfully directed a resident at Ft. Detrick through an ultrasound examination of a health volunteer. The image quality and fidelity of motion provided by the telemedicine system were judged acceptable by all participating radiologists. All participating radiologists found it sufficient to simply view the ultrasound images. They did not feel that it was necessary to view the position of the transducer even though this function was accessible by simply switching the video source.

The remote ultrasound system was also used for remote training (telementoring) exercises. Residents at Ft. Detrick were given a lecture on the detection of ballistic injuries and directed through the examination of specially prepared chicken breast tissue in which projectiles had been embedded. The lecture was delivered by a Military radiologist in Chicago. On a separate occasion, the same radiologist delivered the lecture and conducted the demonstration at Ft. Detrick for a collection of observers in Chicago.

The video bridge to the U.S. Military's conventional teleconference systems allowed the project team to demonstrate the effects of bandwidth and image compression on image quality. More importantly, however, it demonstrated the power of integrated, world-wide telecommunications. Several times per day, live telemedicine conferences were held with Military medical personnel in the field in Haiti. Several patient cases were reviewed with experts in Chicago. The video bridge was also used to permit project team members to brief representatives of the tri-service Surgeons' General on the status of the project and the RSNA conference.

### **Network Performance**

An ATM LAN was established in the Section of Radiologic Computing and Imaging Science at Penn State. A Fore Systems ASX-100 switch (Fore Systems, Inc. Warrendale, PA) was connected to a Fore Systems ASX-200 switch by a DS3 rate (44.7360 Mbps) circuit. One Sun SparcStation 20/60 was attached via an OC-3 (155.25 Mbps) fiber circuit to each switch. Figure 4 illustrates the results of averaging 5 runs at each combination of socket size and Transport protocol data unit (Msg) size. Results for both direct OC-3 connections through a single switch and the dual switch connected by DS3 configurations are presented. The maximum transfer rate for the OC-3 circuit was 87.59 Mbps which occurred when an 8KB message was transmitted using a 32KB socket size. The maximum transfer rate for the DS3 circuit was 35.67 Mbps which occurred when an 4KB message was transmitted using a 56KB socket size.

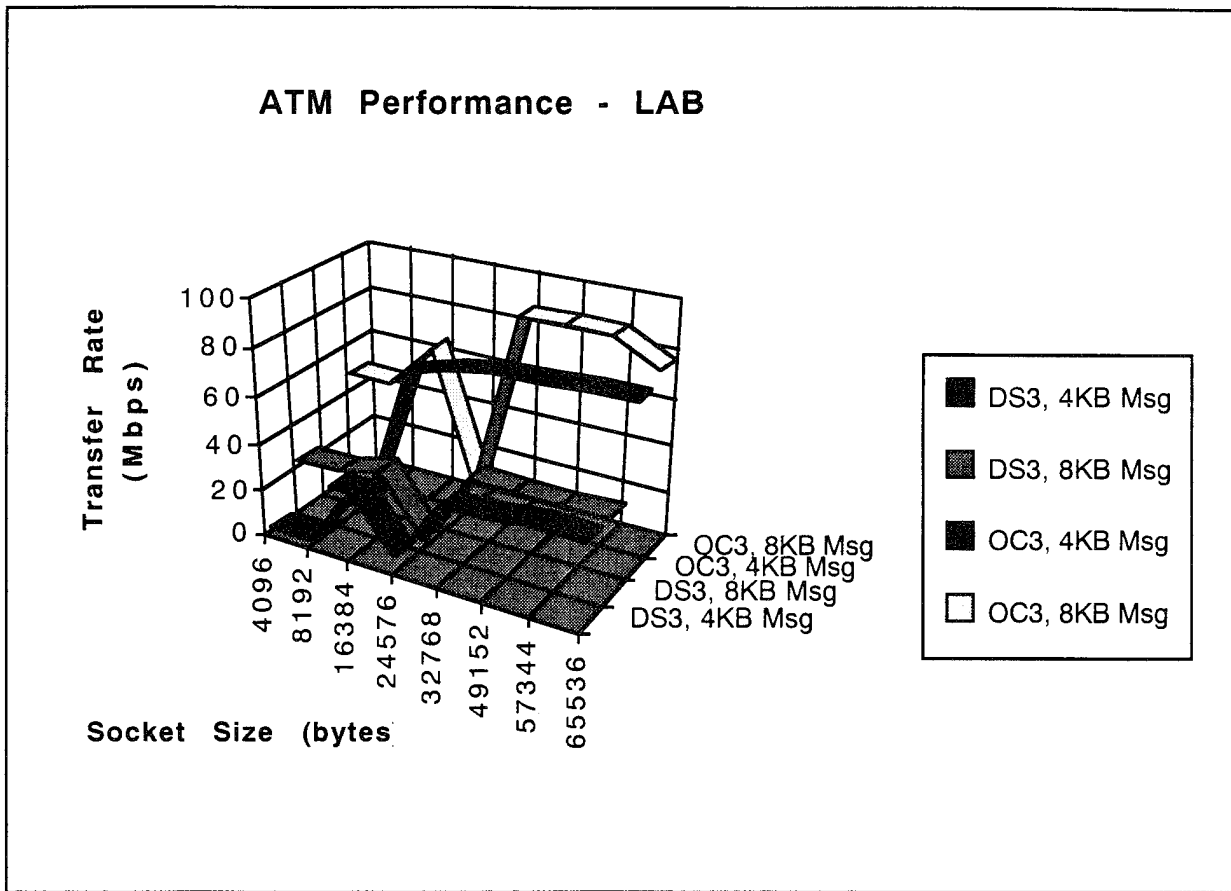

Figure 4. Socket to Socket Transfer Rates  
TCP/IP-ATM: LAN and Simulated WAN

Figure 5 illustrates the results of a similar experiment run between two Sun SparcStation 20/60 workstations connected via OC-3 to a local ASX-100 switch and with the LAN switches interconnected via the DS3 rate WAN. Packet size was varied from 4KB up to 64 KB. The maximum transfer rate was 4.99 Mbps which occurred when an 8KB message was transmitted using a 64KB socket size. The corresponding peak transfer rate between Chicago and San Mateo was 5.14 Mbps with a Socket Size of 64KB and a 32 KB message.

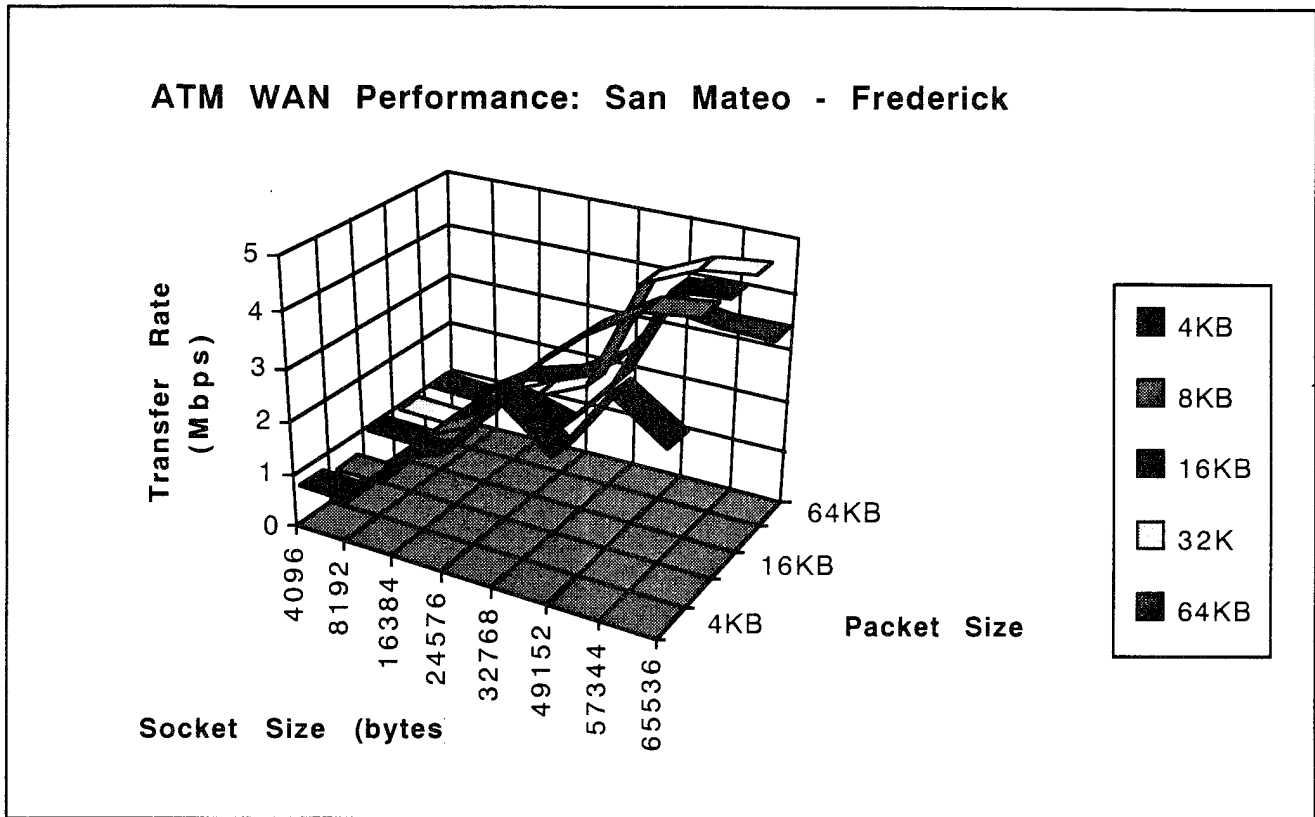

Figure 5. Socket to Socket Transfer Rates TCP/IP-ATM: WAN

Transfer rates were heavily dependent on the performance of the Storage Service Provider's disk subsystem. In the Laboratory transfers as high as 40 Mbps were observed. On the WAN, the Transport layer transfer rate dominated performance.

### Discussion

There was great disparity between the measured performance of TCP/IP - ATM in the simulated WAN (laboratory) and the real WAN. It was observed that the peak transfer rate in the WAN is roughly proportional to the ratio of socket size and the end-to-end transport delay. The Sprint Broad Band Operations Center measured the transport delay between Chicago and San Mateo to be approximately 70 ms which translates to a maximum possible transfer rate of approximately 7.1 Mbps. Increasing the socket size would, in theory, improve WAN performance up to the limit imposed by increased delay due to larger data sets to repeat when errors occur. Currently, however, it is not possible to increase TCP socket size beyond 64 KB.

## CONCLUSIONS

The principle objectives of the demonstration were twofold:

1. Demonstrate the clinical efficacy of ATM technology for telemedicine and wide area PACS.
2. Provide a clinical demonstration of as an open system interface between a workstation and PACS (particularly over a high speed network such as ATM).

The key results included: extension of the standard to support ATM, an open-system interface to MDIS, a prototype telemedicine workstation with video teleconferencing, high resolution image display, patient vital signs display and database query/retrieval functionality.

Future research objectives that arise from the preliminary results reported here include:

- Network Testbed
  - Characterize/TCP/ATM performance
- Clinical impact of Intra-Institutional Telemedicine
  - Quality Improvement
  - Telepresence Ultrasound Examinations
- Workstation Testbed
  - Human Contrast Perception
  - Image Navigation.

We have demonstrated a true telemedicine system which can interconnect tertiary treatment centers with primary clinics, hospitals and even deployable medical treatment centers. The integration of the medical imaging interchange standard with high speed ATM switching permits open access query/retrieve capability, at interactive speeds, with the Medical Diagnostic Imaging Support (MDIS) system over continental distances. The proper application of modern communication standards allows the "multi-media" mixing of teleconferencing, vital signs monitoring, and image/exam data retrieval necessary to form a comprehensive telemedicine system. Open architecture connections to MDIS, and the proper utilization of standards, permits a University designed workstation to interact, in real time, with remote systems, over common carrier communication circuits. The ability to retrieve historical patient information as well

as new information is essential in order for telemedicine to provide a high quality of medical treatment, and is a unique feature of this demonstration. We are convinced that the right combination of standards can make the "information superhighway" suitable for the delivery of high quality telemedicine services.

## REFERENCES

- Curtis, D.J., B.W. Gayler, J.N. Gitlin, and M.B. Harrington. 1983. Teleradiology: Results of a Field Trial. Radiology. vol. 149, pp. 415-418.
- De Prycker, M., R. Peschi and T. Van Landegem. 1993. "B-ISDN and the OSI Protocol Reference Model" IEEE Network, vol. 7, pp.10-18.
- Gitlin, J.N. 1986. Teleradiology. Use of Computers in Radiology, Radiologic Clinics of North America. vol. 24, pp. 55-68.
- Glicksman, R., D. Wilson, J. Perry, and F. Prior. 1992. Architecture of a High Performance PACS Based on a Shared File System. In: Medical Imaging VI: PACS Design and Evaluation, R.G. Jost (ed.), Proceedings SPIE. vol. 1654, pp. 158-168. The International Society for Optical Engineering, Bellingham, Washington.
- Goeringer, F. 1990. Medical Diagnostic Imaging Support Systems for Military Medicine. In: Picture Archiving and Communication Systems (PACS) In Medicine, H.K. Huang, O. Ratib, A.R. Bakker and G. Witte (eds.), pp. 213-230. NATO ASI Series, Springer-Verlag, Berlin.
- Goeringer, F. and R. Leckie, 1994. U.S Military Medicine: PACS, Telemedicine & Personal Digital Assistant Devices. In: SCAR94 Computer Applications to Assist Radiology, J. Boehme, A. Rowberg, N. Wolfman (eds.), pp. 279-285. Symposia Foundation, Carlsbad, CA.
- Hindel, R. 1994. "Demonstrations of DICOM" In: Implementation of the DICOM 3.0 Standard, R. Hindel (ed.), pp. 39-43. Radiological Society of North America, Oak Brook, IL.
- Horii, S.C., F.W. Prior, W.D. Bidgood, C.R. Parisot, and G. Claeys, 1993. DICOM: An Introduction to the Standard. Pamphlet published by Radiological Society of North America.

- Jones, R., 1995. "Netperf Homepage." Hewlet Packard. (available electronically:  
<http://www.cup.hp.com/netperf/NetperfPage.html>)
- Kuduvalli, G.R., R.M. Rangayyan, and J.E.L. Desautes. 1991. High-Resolution Digital Teleradiology: A Perspective. Journal of Digital Imaging. vol. 4, pp. 251-261.
- Luotonen, A., 1994. "cgiutils Manual," CERN. (available electronically:  
<http://info.cern.ch/hypertext/WWW/Daemon/User/CGI/cgiutils.html>)
- Mun, S.K. 1992. Command-Wide Teleradiology for the U.S. Forces in Korea. In: Medical Imaging VI: PACS Design and Evaluation, R.G. Jost (ed.), Proceedings SPIE. vol. 1654, pp. 81-88. The International Society for Optical Engineering, Bellingham, Washington.
- Nadel, L.D., M.A. Forrester, M.E. Glenn, W.P. Johnson, D.A. Lafko and F. Goeringer. 1989. Prototype System for Digital Image Management in Combat Casualty Care. In: Medical Imaging III: PACS System Design and Evaluation, R.H. Schneider, S.J. Dwyer and R.G. Jost (eds.), Proceedings SPIE. vol. 1093, pp. 511-522. The International Society for Optical Engineering, Bellingham, Washington.
- "National Information Infrastructure: Agenda for Action," U.S. DOC, Secretary Ronald H. Brown, Tab A, September, 1993 (available electronically: <http://iitf.doc.gov>).
- Prior, F., R.G. Leckie, R. Glicksman, R. Freeman, M. Zaidel, F. Goeringer, D. Channin, and G. Norton, 1994. "A DICOM/Asynchronous Transfer Mode (ATM) Interface Allowing Open Access to MDIS and Other PACS," *Radiology*, 193(P):474.
- Schatz, B.R. and J.B. Hardin, 1994. "NCSA Mosaic and the World Wide Web: Global Hypermedia Protocols for the Internet," *Science*, 262:895-901.
- Smith, D.V., S. Smith, G.N. Bender, J.R. Carter, M. A. Cawthon, R. G. Leckie, J.C. Weiser, J. Romlein, and F. Goeringer, 1994. "Lessons Learned and Two Years Clinical Experience in Implementing the Medical Diagnostic Imaging Support (MDIS) System at Madigan

Army Medical Center," In: Medical Imaging 1994: PACS Design and Evaluation, Jost, R.G. (ed.), Proceedings SPIE. Vol. 2165, pp. 538-555. The International Society for Optical Engineering, Bellingham Washington.

Wilson, D.L., F.W. Prior, and R.A. Glicksman, 1995. "Virtual PACS, Open Systems, and the National Information Infrastructure." In: Medical Imaging 1995: PACS Design and Evaluation, Jost, R.G. (ed.), Proceedings SPIE. The International Society for Optical Engineering, Bellingham Washington. (in press)

## APPENDIX

Brochure describing the RSNA 95 DICOM/ATM Telemedicine demonstration.

# DICOM / ATM Telemedicine

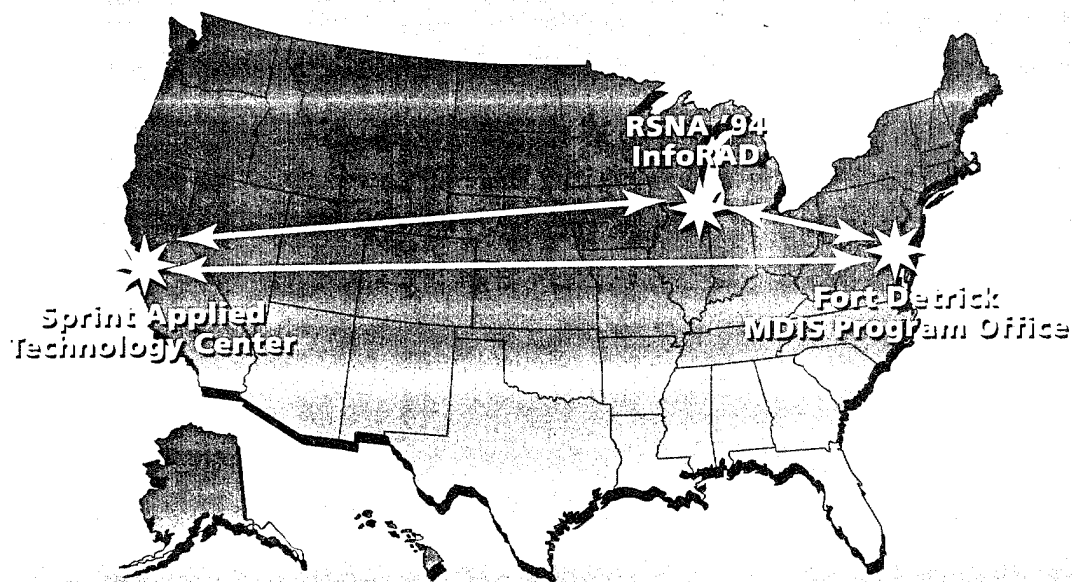

*Coexisting Goals*

*Diagnostic Quality Image Transmission*

*Real Time Digital Video Teleconferencing*

*Real Time Vital Signs Monitoring*

**DICOM • TCP/IP • ATM**

## INTRODUCTION

**T**elemedicine" and the "Information Superhighway" have become hot topics in medicine. Most of what has been published about telemedicine involves basic teleconferencing capabilities. While a key component of any telemedicine system, teleconferencing capability alone does not address the complete picture for remote diagnosis and treatment of medical injuries and disease.

**A** telemedicine system must provide a complete set of clinical information about a patient to the physician/specialist in real time. This not only involves information sent ("pushed") from the clinical setting to the physician's workstation but also requires that the physician be able to access ("pull") information about the patient's current and past medical condition in a time and space independent manner.

**I**n this demonstration, we combine high-speed wideband communications technology (OC-3, DS3), bandwidth-on-demand

technology (ATM), and the DICOM standard for medical information interchange (particularly the DICOM Query/Retrieve service class), with the tri-service Medical Diagnostic Imaging Support (MDIS) PACS system and an open architecture workstation, to create a telemedicine capability that is both time and space independent.

**T**he high speed and dynamic flexibility of the selected communication protocols support the necessary mix of multimedia information in a unified and clinically useful manner on a specially designed workstation. Live teleconferencing, requiring moderate bandwidths on a continuous basis, is integrated with patient vital signs (low bandwidth data, bursty and continuous) and diagnostic quality teleradiology (bursts of very high bandwidth data) to provide the physician with a "telepresence" to the patient. Wide area communications, provided by common carriers, allows the physician to perform effective telemedicine over continental distances.

## CLINICAL SCENARIO

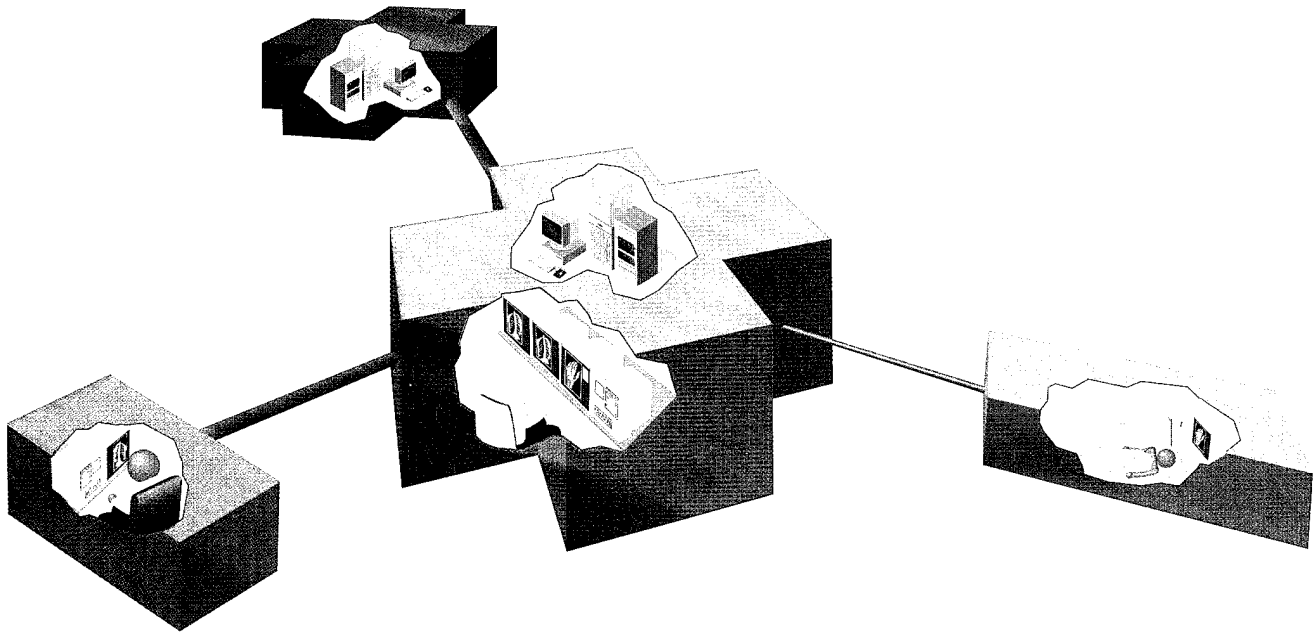

**T**his demonstration shows that diagnostic medicine can be brought to the patient, thereby avoiding undesirable patient travel. The clinical concept for this demonstration involves a multisite, coast-to-coast telemedicine system. A specialist at a major medical center or trauma center (represented by InfoRAD) may directly provide primary care to a patient at a remote hospital or clinic (represented by Ft. Detrick, MD). Computer teleconferencing is combined with remote vital signs monitoring and medical image transmission via the DICOM standard to provide a complete picture of the patient's current condition. Asynchronous transfer mode (ATM) communication allows the physician to connect to this and other sites and provides the variable bandwidth needed for both continuous (teleconferencing) and on-demand (telerradiology) transmission over the same wide-area communication service.

**A**n intuitive but powerful user interface allows the physician to visually examine the patient, confer with the nurse/medic at the patient's bedside, monitor and review the patient's vital signs, and simultaneously view high-resolution digital x-rays and/or images from other medical imaging modalities. This, however, is not the

complete picture. Imagine a circumstance during the examination of a patient at Ft. Detrick wherein the physician here at InfoRAD notices a suspicious lesion on the patient's current x-ray. The lesion appears unrelated to the patient's current injury. Is this cause for concern? The clinical determination may depend on the ability to view old images, which may be located at remote medical centers.

**T**he ability to network across the country (or even across the world) via wide area ATM is brought into play to resolve this situation. The physician/specialist can now connect live to another location (in this demonstration, San Mateo, California). The 2-hour time difference between Illinois and California need not be a factor because the physician does not need live assistance. The physician merely needs to query the MDIS system there for the necessary historical images and, via DICOM Query/Retrieve services, pull the necessary data back to the workstation here at InfoRAD. The historical examinations thus accessed clearly show the anomaly in the patient's current x-ray to be an old injury and of no further concern.

# DEMONSTRATION SYSTEM

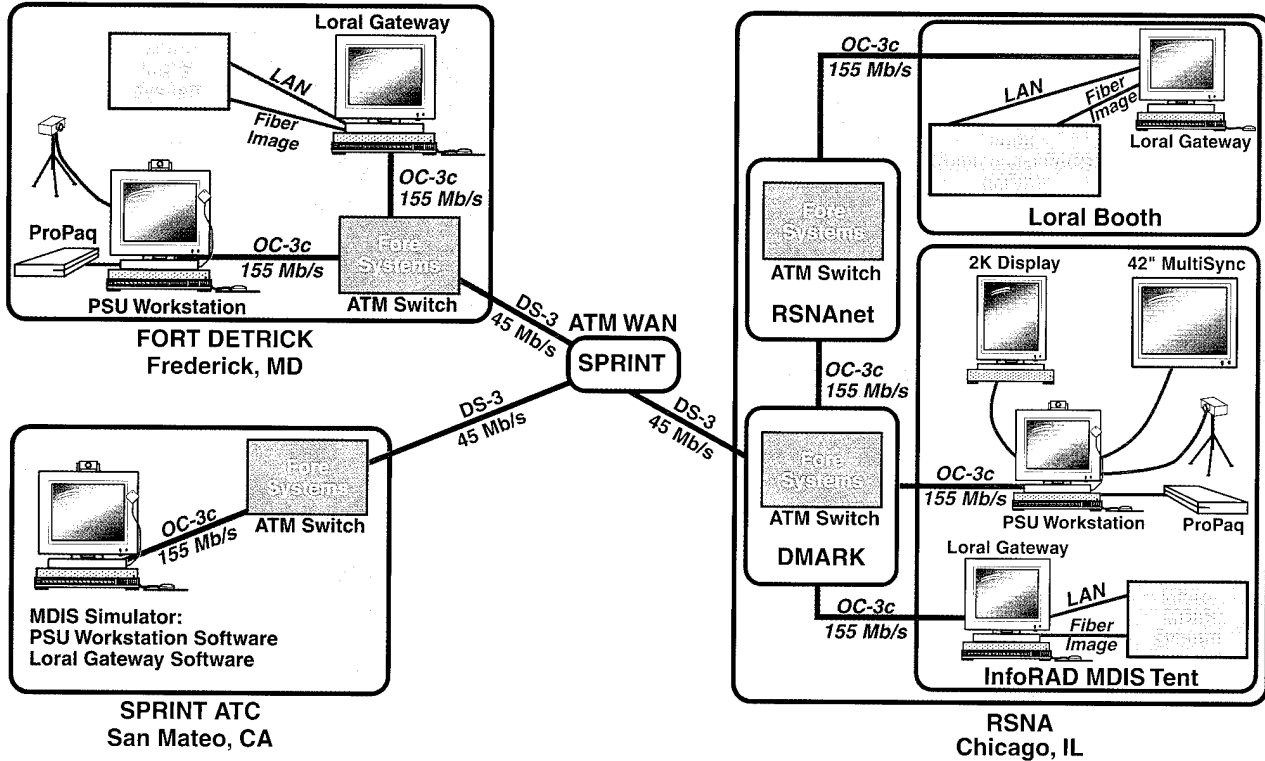

This demonstration system realistically integrates a number of key technologies that we feel are essential to a successful telemedicine system:

- *Open architecture:* A workstation, built by the Section of Radiological Computing and Imaging Science of Pennsylvania State University College of Medicine uses a standards-based design approach to ensure interoperability with remote commercial and military systems. The workstation features standard OC-3, ATM, and TCP/IP communication protocols integrated with DICOM query/retrieve, teleconferencing, and vital signs monitoring. One workstation is located here at InfoRAD, another is located at Ft. Detrick, MD, and a third is in San Mateo, CA. These workstations can communicate with each other, in pairs, and with MDIS systems, all over wide-area ATM services supplied by U.S. Sprint and the applicable regional Bell operating companies.
- *Medical Diagnostic Imaging Support (MDIS) system:* "Micro" (i.e., clinical, deployable)

MDIS systems are located here at InfoRAD, at Ft. Detrick, and at San Mateo. A full size (full hospital capable) MDIS in the Loral Medical Information Systems commercial exhibit booth here at RSNA is also networked into the demonstration. MDIS provides full image management, archival storage, and communication capabilities for all medical imaging modalities, patient demographic information, and results reporting.

- *High-speed communications:* Telemedicine cannot be successful unless it is time and space independent. The remotely located physician/specialist *must* be able to interact with the patient, nurse/medic and local physician *and with relevant historical medical information* in real time. OC-3 (155 Mb/s) fiber optic communication is used for local connections, and DS-3 (45 Mb/s) connections are used for wide area (coast-to-coast) service. Asynchronous transfer mode (ATM) switches provide a high-speed switched environment for the essential ingredients of multisite, multimedia communication.

# PROTOCOL LAYERS

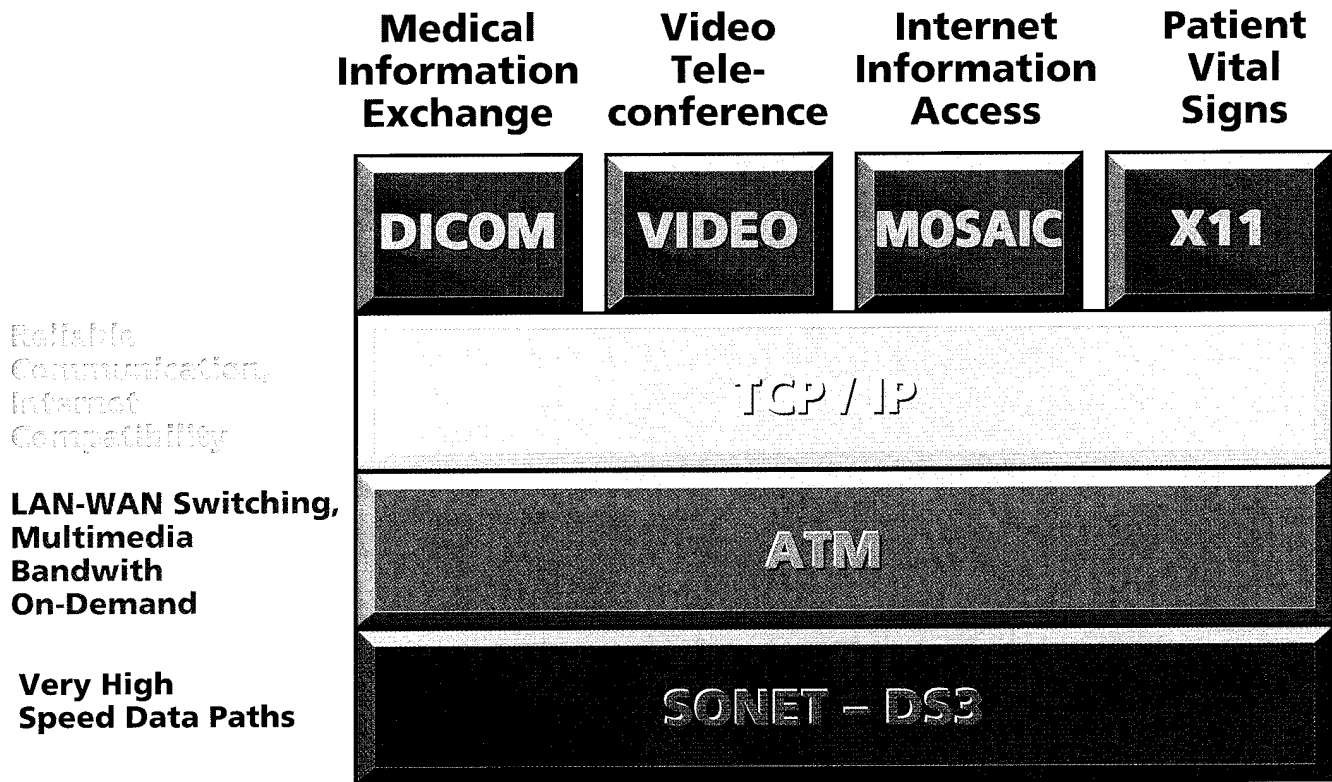

**T**erms like "OC-3," "fiber optic communication" and "TCP/IP," are sometimes associated with "open systems" and the "information superhighway." While there is some truth to this, a successful telemedicine system requires a careful and well thought out *combination* of these protocols. No single protocol will do the job!

**T**he telemedicine "protocol stack" is like a layer cake. All of the layers must be present, in the correct order, and with the correct set of ingredients in order to have a successful final product.

**T**he base of the stack provides the core of the high-speed communication capability via Sonet OC-3 (155 Mb/s) fiber optic and DS-3 (45 Mb/s) communication standards. On top of this, asynchronous transfer mode (ATM) technology provides switching functionality and the variable bandwidth necessary to integrate the multimedia telemedicine environment. Trans-

mission Control Protocol/Internet Protocol (TCP/IP) provides for reliable, end-to-end data transfer and compatibility with the Internet, the prototype for the Information Superhighway.

**O**n top of this basic communication protocol stack are the applications and the upper layers that support them. Of particular significance to the radiological community is the adaptation of the Digital Imaging and Communications in Medicine (DICOM) standard to the high-speed ATM/OC-3 communications base. This permits, for the first time, DICOM query/retrieve services to be run, coast-to-coast, at interactive speeds! We have successfully demonstrated that a physician seated at a workstation anywhere in the world can interrogate remote databases and pull back large (e.g., 10 megabytes per image) medical data sets for review, in "real time" and at full diagnostic resolution (e.g., 12 bits per pixel, 2K x 2.5 pixels, with no lossy compression applied).

# THE INFORMATION SUPERHIGHWAY IN MEDICINE

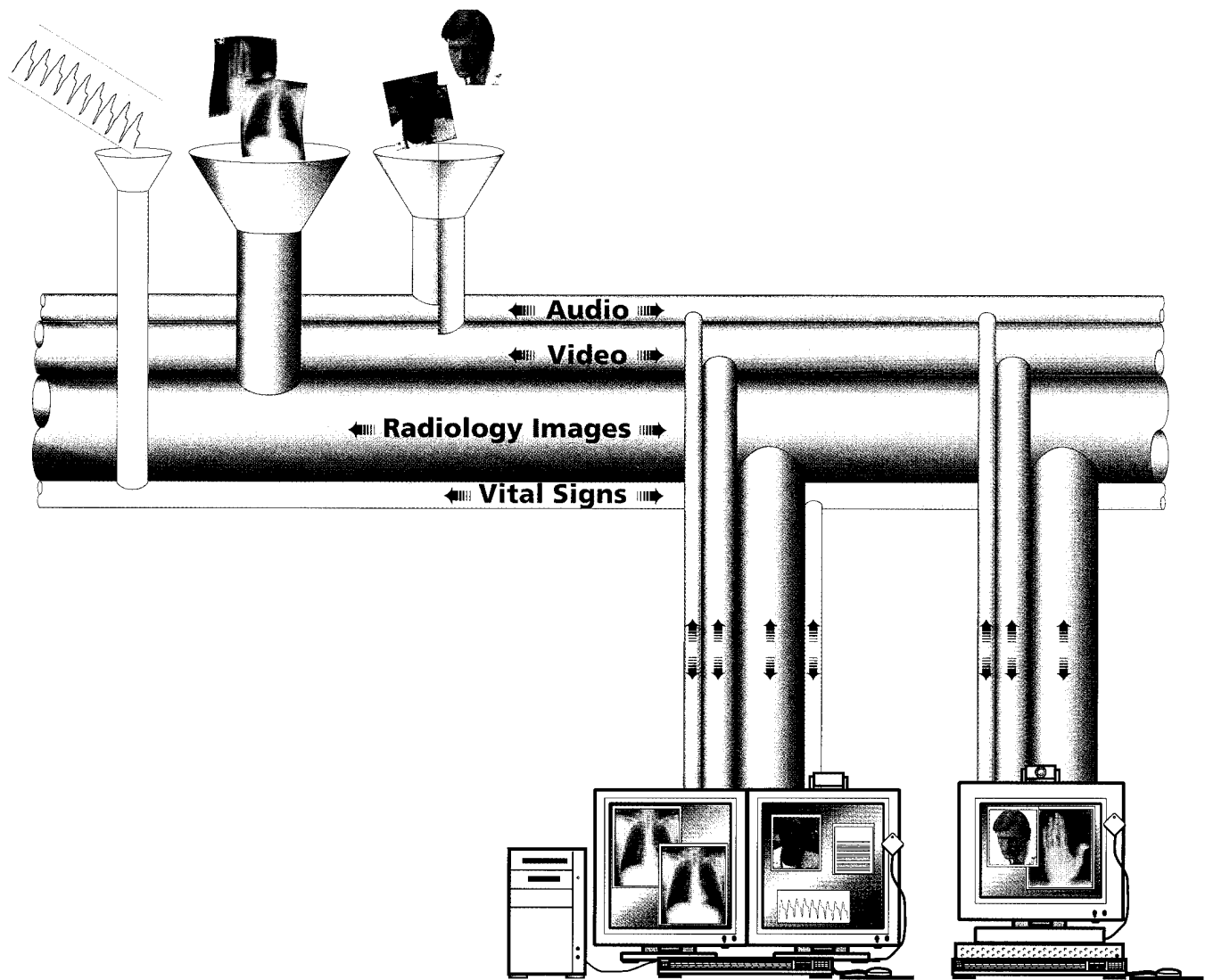

**T**here has been tremendous publicity surrounding the "information superhighway," its creation, and its application to medicine. We have proven that the technologies do indeed exist today that, with proper integration, can support a clinically viable telemedicine system.

**T**elemedicine is a multimedia application. Just about all known data types — digitized live video and audio, DICOM-encoded medical images and related data, text, graphics, and digitized vital signs — need to be integrated into a time and space independent, medically relevant system. This is not a trivial matter, particularly for the underlying communication

infrastructure, because each of these media types has a different set of requirements. Live video and audio require continuous transmission at moderate bandwidths (with compression). In stark contrast, high-resolution (diagnostic quality) medical images require very-high-speed bursts of data transmission. Patient vital signs monitoring requires low bandwidth but continuous transmission, while data queries and textual information operate in short bursts of moderate bandwidth. We have demonstrated that ATM technology can successfully handle all of these data types at once, over continental distances as well as within a single facility or campus.

## SUMMARY

**W**e have demonstrated a telemedicine system that can interconnect tertiary treatment centers with primary clinics, hospitals, and even deployable medical treatment centers. Integration of the DICOM medical imaging interchange standard with high-speed ATM switching permits open access examination/image query/retrieve capability, at interactive speeds, with the Medical Diagnostic Imaging Support (MDIS) system over continental distances.

**P**roper application of modern communication standards allows multimedia mixing of teleconferencing, vital signs monitoring, and image/examination data retrieval nec-

essary to form a comprehensive telemedicine system. Open architecture connections to the MDIS system and the proper use of standards permit a university designed workstation to interact, in real time, with remote systems, over common-carrier-provided communication circuits. The ability to retrieve historical patient information along with new information, is essential for telemedicine to support high quality medical treatment. This is a unique feature of our demonstration.

**W**e are convinced that the right combination of standards can make the information superhighway suitable for delivery of high-quality telemedicine services.

**Academia**



**Government**

**Industry**

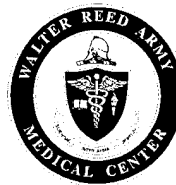
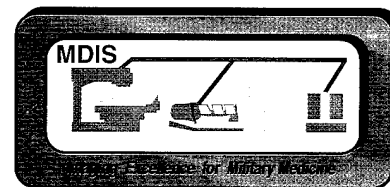
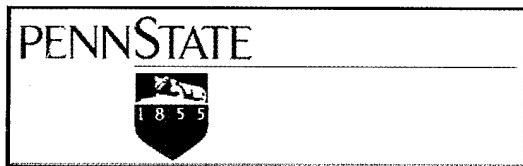

For further information, contact:

Medical Advanced Technology Management Office  
U.S. Army Medical Research and Materiel Command  
SGMMA-OMD  
Fort Detrick, Frederick, MD 21702-5001  
COL. Fred Goeringer  
Internet: [goeringer@ftdetrck-atmo1.army.mil](mailto:goeringer@ftdetrck-atmo1.army.mil)

Loral Medical Imaging Systems  
3200 Zanker Road  
San Jose, CA 95134  
Robert Glicksman, Chief Scientist  
Internet: [bobg@wdl.loral.com](mailto:bobg@wdl.loral.com)

PennState  
Milton S. Hershey Medical Center  
Section of Radiologic Computing and Imaging Science  
P.O. Box 850  
Hershey, PA 17033  
Fred W. Prior, Ph.D.  
Internet: [prior@xray.hmc.psu.edu](mailto:prior@xray.hmc.psu.edu)  
URL: <http://www.xray.hmc.psu.edu>

Walter Reed Army Medical Center  
Department of Radiology  
Washington, DC 20012-9215  
Maj. Robert Leckie, M.D.  
Internet: [leckie@ftdetrck-atmo1.army.mil](mailto:leckie@ftdetrck-atmo1.army.mil)