

TECHNICAL SUPPORT FOR ROCKY MOUNTAIN ARSENAL

**Offpost Interim Response Action and
Remedial Investigation/Feasibility Study
Draft Data Management Plan**

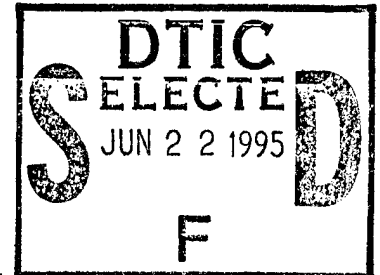

March 1989

Contract Number DAAA15-88-D-0021/0001

RI/FS-1

This document has been approved for public release and sale; its distribution is unlimited.

PREPARED BY:

HARDING LAWSON ASSOCIATES

PREPARED FOR:

**OFFICE OF THE PROGRAM MANAGER
ROCKY MOUNTAIN ARSENAL CONTAMINATION CLEANUP**

**Rocky Mountain Arsenal
Information Center
Commerce City, Colorado**

DRAFT

THE VIEWS, OPINIONS, AND/OR FINDINGS CONTAINED IN THIS REPORT ARE THOSE OF THE AUTHOR(S) AND SHOULD NOT BE CONSTRUED AS AN OFFICIAL DEPARTMENT OF THE ARMY POSITION, POLICY, OR DECISION UNLESS SO DESIGNATED BY OTHER DOCUMENTATION.

THE USE OF TRADE NAMES IN THIS REPORT DOES NOT CONSTITUTE AN OFFICIAL ENDORSEMENT OR APPROVAL OF THE USE OF SUCH COMMERCIAL PRODUCTS. THE REPORT MAY NOT BE CITED FOR PURPOSES OF ADVERTISEMENT.

19950620 073

EDG 89-0252

TABLE OF CONTENTS

	<u>Page</u>
1.0 INTRODUCTION	1
1.1 PURPOSE	1
1.2 OBJECTIVE	1
2.0 DATA TYPES	3
2.1 FIELD DATA	3
2.2 ANALYTICAL DATA	4
3.0 SAMPLE CONTROL	5
3.1 FIELD CUSTODY PROCEDURES	5
3.1.1 Sample Identification	5
3.1.2 Field logbooks	6
3.1.3 Sample Labels	8
3.1.4 Chain-Of-Custody Records	9
3.1.5 Transfer of Custody and Shipment	10
3.2 LABORATORY CUSTODY PROCEDURES	10
4.0 CORRECTIONS TO DOCUMENTATION	13
5.0 ELECTRONIC DATA MANAGEMENT	14
5.1 PROCEDURES	14
5.2 DATA CODING	15
5.3 DATA FLOW	16
5.4 DATA TRACKING	18
5.5 HARDWARE AND SOFTWARE RESOURCES	18
6.0 QA/QC PROGRAM	20
6.1 DATA VALIDATION	21

TABLE OF CONTENTS
(Continued)

	<u>Page</u>
6.2 APPROACH TO DATA VALIDATION	22
6.2.1 Field Measurement Data Validation	22
6.2.2 Laboratory Analytical Data Validation	23
7.0 DOCUMENT CONTROL SYSTEM	26
7.1 DEFINITIONS	26
7.2 PROCEDURE	27
7.2.1 Incoming Documents	28
7.2.2 Outgoing Documents	29
7.2.3 HLA Retention Policy	30

LIST OF REFERENCES

APPENDICES

A - HARDING LAWSON ASSOCIATES FIELD FORMS

DRAFT

Accession For	
NTIS CRA&I	<input checked="" type="checkbox"/>
DTIC TAB	<input type="checkbox"/>
Unannounced	<input type="checkbox"/>
Justification	
By	
Distribution/	
Availability Codes	
Dist	Avail and/or Special
A-1	

1.0 INTRODUCTION

The Data Management Plan prepared for the RI/FS - 1 investigation provides procedures, organization, and methods that comply with the U.S. Army Toxic and Hazardous Materials Agency (USATHAMA) Quality Assurance (QA) Program and Installation Remediation Data Management System. This plan sets forth specific protocol for generation, management, distribution, and retention of data and documents generated during the RI/FS - 1 investigation.

Subsequent sections of the Data Management Plan are organized as follows:

- Section 2.0 Data Types
- Section 3.0 Sample Control
- Section 4.0 Corrections to Documentation
- Section 5.0 Electronic Data Management
- Section 6.0 Quality Assurance Program
- Section 7.0 Document Control System

1.1 PURPOSE

The purpose of the Data Management Plan is to:

- Provide a consistent framework for generation of analytical data in support of the IR Program conducted by USATHAMA at RMA
- Establish standard practices that permit HLA and USATHAMA to exchange analytical results in a manner consistent with the project QA Program
- Establish protocol for verifying the precision, accuracy, representativeness, comparability, and completeness of analytical results for the RI/FS - 1 project

1.2 OBJECTIVE

The objective of this plan is to describe the steps that will be used to control the flow of data from sample collection through analysis, reduction, validation, and reporting in the format required by USATHAMA. Technical data (field, office, and laboratory) will be tracked

and validated to meet the Data Quality Objectives (DQOs) of the Work Plan and the RIFS-1 Quality Assurance Project Plan (QAPP). The data collection and QA procedures used to assess the technical utility of analytical data are described in this report and QA presented in more detail in the QAPP (HLA, 1989). All documents generated by HLA will be managed using HLA's Document Control System and will be reviewed by qualified HLA personnel for completeness and accuracy.

DRAFT

2.0 DATA TYPES

This section describes the geotechnical and analytical data types to be generated during the offpost RI/FS-1 process.

2.1 FIELD DATA

Field data include the raw data generated by the field investigation and may include (but are not limited to) the following:

- Field notebooks
- Field investigation reports
- Field instrument readings and calibration records
- Boring logs/soil sampling forms
- Well completion reports
- Air sampling records
- Biota sampling records
- Ground-water sampling forms
- Soil sampling forms
- Surface-water sampling forms
- Waste sampling forms
- Chain-of-custody forms
- Water-level measurements
- Surface-water flow rates
- Aquifer test data
- Meteorological data
- Maps and photographs
- Sampling labels

2.2 ANALYTICAL DATA

Analytical data include results of chemical or physical analyses of field samples and the results of geotechnical analyses. Analytical data may include (but are not limited to) the following:

- Air sample analytical results
- Biota sample analytical results
- Ground-water sample analytical results
- Soil sample analytical results
- Sediment sample analytical results
- Surface-water sample analytical results
- Waste sample analytical results
- Physical properties test results from analysis of soil samples
- Maps (e.g. water levels, chemical distribution)
- Geologic sections
- Analysis/calculations of aquifer test results
- Fate and transport calculations
- Costing scenarios
- Computer modeling

3.0 SAMPLE CONTROL

Sample custody procedures will be followed from sample collection, transfer, analysis, and disposal. This section describes the custody procedures for samples controlled during offpost RI/FS-1 activities. Procedures described in this plan comply with the USATHAMA regulations for IR projects and other applicable EPA sampling guidelines. The purpose of these procedures is to ensure that sample integrity is maintained during collection, transport, analysis, and storage. Sample custody is divided into field procedures and laboratory procedures.

3.1 FIELD CUSTODY PROCEDURES

Samples will be handled by as few people as possible. Each sample will be labeled using waterproof ink and will be sealed immediately after collection. The field sampler is responsible for custody of samples until they are transferred to the site manager and then to the laboratory.

The HLA Project Manager or designated representative will be responsible for ensuring that custody procedures are followed during field sampling.

3.1.1 Sample Identification

A critical element in data management is the consistent recording of data collected in the field. HLA uses a combination of field forms and field notebooks to meet this goal. Copies of HLA's field forms are contained in Appendix A of this document. Sample identification documents will be carefully prepared to maintain identification and chain-of-custody records to control sample disposition. Sample identification documents that will be utilized during RI/FS-1 activities at RMA include:

- Field logbooks and/or field data records (FDRs)
- Sample labels

- Chain-of-custody forms
- Analytical lot designation forms

The method of identification of the sample will depend on the type of measurement and analyses performed. In-situ measurements are recorded directly in logbooks or FDRs. Information provided on these records includes the project code, station number, station location, date, time, sampler, field observations, and remarks. Examples of in-situ measurements include pH, temperature, conductivity, flow measurements, continuous air monitoring, and stack gas analysis.

Samples to be subjected to analyses other than in-situ measurements are identified by a sample label. These samples will be transported from the sampling location to a laboratory or other location for analysis. Each portion of a field sample will be preserved in accordance with USATHAMA QA procedures, and the sample container will be identified with a label.

During all phases of analyses, sample custody will be maintained. If a composite or grab sample is to be split, aliquot portions will be placed in individual containers. Labels will contain identical information.

3.1.2 Field Logbooks

Field logbooks will be used to record data collection activities performed at the site. They will be assigned to field personnel and will remain in the custody of field personnel during sampling activities. Each logbook will be identified by a project-specific number.

At the beginning of each day, the date, start time, weather, field personnel present, level of personal protective equipment, and the name of the person making the entry will be recorded. The names of visitors, their affiliations, and the purpose of their visit will also be recorded. All information pertinent to a field survey and/or sampling event will be recorded

in the field logbook. Entries in the logbook will include, but will not be limited to, the following:

- USATHAMA project for which sampling is being conducted
- Unique, sequential field sample number
- Matrix sampled (e.g., ground water, soil)
- Sample depth
- Sampling date and time
- Specific sampling location in sufficient detail to allow resampling at the same location
- Method of sampling
- Preservation techniques, including filtering
- Analytes of interest
- Volume of water removed during well development
- Observations during sampling
- Results of field measurements, such as depth to water, temperature, conductivity and pH
- Signature of the person performing the sampling
- Date of shipment, number of shipping containers, number of samples, and carrier

In addition to the sampling logbook, each sample container will be labeled in waterproof ink with the following information:

- Installation name
- Sequential field sample number
- Sampling date
- Analysis to be performed
- Preservative/filtration

The information included on the HLA standard field boring logs, field sampling data sheets, daily field activity reports, or chain-of-custody records will not necessarily be repeated in the sampling logbook. Logbooks will contain information for which there are no standard forms.

3.1.3 Sample Labels

Samples will be identified by unique sample labels. Preprinted sample labels will be provided and will be attached to each sample collected. Labels will be protected from water and solvents with clear label protection tape. If labels are lost, voided, or damaged, the sample information will be noted in the appropriate field logbook. The information recorded on each label will include:

- Project code
- Site ID, a number assigned by the project coordinator or designated representative
- Analyses requested
- Date of sample collection (Julian date)
- Time, a four-digit number indicating the 24-hour time of collection (e.g., 0945 is 9:45 a.m. and 1629 is 4:29 p.m.)
- Sampling station description specified by the project coordinator
- Sampler's signature
- Remarks, including pertinent information such as preservative used
- Laboratory sample number (to be completed by the receiving laboratory)

Custody seals (evidence tape) will be used to preserve the integrity of the samples from the time they are collected until they are opened in the laboratory. The seals will carry the date and time of sealing and the sampler's initials. The seal will be attached in such a way that it will break when the sample container is opened. Two seals will be placed on each

shipping container (cooler), one at the front and one at the back. Clear tape will be placed over the seals to ensure that seals are not accidentally broken during shipment.

3.1.4 Chain-of-Custody Records

To establish the documentation necessary to trace sample possession from the time of sample collection through individual sample analysis to storage after analyses, a chain-of-custody record will be completed for and will accompany every sample and every shipment of samples. HLA will be responsible for completion of chain-of-custody records (see Appendix A) throughout the sampling program until the samples have been shipped or delivered to the laboratory. The sampling portion of the chain-of-custody record will, at a minimum, contain:

- Chain-of-custody number
- Name of sampling team members
- Sample tag number
- Signature of sampler or bottle preparer
- Date and time of sample collection
- Sample depth
- Media type
- Signatures of persons involved in the chain of possession
- Inclusive dates of possession
- Preservation
- Laboratory designation
- Analysis to be performed
- Name of person receiving the samples
- Laboratory sample number
- Date and time of sample receipt by the laboratory

- Analyses requested
- Sample condition (recorded in "Remarks")

3.1.5 Transfer of Custody and Shipment

All samples will be accompanied by a chain-of-custody record. When transferring the possession of samples, the individuals relinquishing and receiving the samples will sign, date, and note the time on the chain-of-custody record. This record documents sample custody transfer from the sampler, often through another person, to the analyst at the laboratory.

Samples will be appropriately packaged for shipment to the laboratory, with a separate custody record accompanying each shipment. Shipping containers will be sealed for shipment to the laboratory. The method of shipment and other pertinent information will be entered in the chain-of-custody record prior to sealing the record in the cooler.

When samples are split with another party, a separate chain-of-custody form will be prepared for those samples and marked to indicate with whom the samples are being split. The person relinquishing the samples to the facility or agency should request the signature of a representative of the appropriate party acknowledging receipt of the samples. If a representative is unavailable or refuses to sign, this will be noted in the "received by" space. When appropriate, as in the case where the representative is unavailable, the Receipt for Sample Form should contain a statement that the samples were delivered to the designated location at the designated time.

3.2 LABORATORY CUSTODY PROCEDURES

The laboratory will designate a sample custodian to accept custody of the shipped samples. The custodian will verify that the information on the sample label matches that on the chain-of-custody record. A checkmark and the individual's initials and date are then placed in the sample tag verification column on the chain-of-custody form. Pertinent

information relating to shipment, pickup, and courier will also be verified on the chain-of-custody records. A checkmark and the person's initials and date are then placed in the sample label verification column on the chain-of-custody form.

Samples will be logged in a bound logbook, preferably one that is installation-specific. Logging the samples into a laboratory-wide sample tracking system (manual or computerized) does not supplant the need for a written project-specific log. Sample information provided in the logbook must include:

- Field sample number
- Date of arrival at the laboratory
- Observations regarding the conditions under which the samples arrived, e.g. broken containers, leakage, lack of temperature control
- Analysis requested
- USATHAMA sample identification number (in addition to any internal laboratory sample numbers) associated with each field sample number

Prior to the analysis, samples are grouped into analytical lots, ordered and assigned an analysis identification number. The laboratory custodian then ensures that all samples are transferred to the appropriate analyst or stored in the appropriate secure area.

Laboratory personnel are responsible for the care and custody of samples from the time they are received until the sample is exhausted or returned to RMA storage. All data sheets and laboratory records will be retained as part of the analysis documentation.

Each laboratory must follow its established system for tracking samples through the laboratory and identifying the supporting documents as required by USATHAMA guidelines.

When sample analyses and necessary QA checks have been completed in the laboratory, the unused portion of the sample secured as evidence must be returned to RMA for storage and disposal. All identifying tags, data sheets, and laboratory records will be retained as part

of the project documentation until the data or documentation is purged by HLA or until the project manager authorizes its disposal.

DRAFT

4.0 CORRECTIONS TO DOCUMENTATION

Original data recorded in field logbooks, chain-of-custody records, and other forms will be written in waterproof ink. None of these documents will be altered, destroyed, or discarded even if they are illegible or contain inaccuracies that require a replacement document.

If an error is made on a document assigned to an individual, that individual will make the correction by drawing a single line through the error, entering the correct information, and initialing and dating the change. The erroneous information will not be obliterated. Any additional errors discovered on a document will be corrected, initialed, and dated by the person who made the entry.

DRAFT

5.0 ELECTRONIC DATA MANAGEMENT

The HLA team will use USATHAMA's Installation Restoration Data Management System (IRDMS) to ensure that data quality objectives are achieved. This approach coupled with the project QA program review procedures will ensure that all data meet acceptance criteria and can be merged into the final data file.

A computer-based data tracking system has been developed by the HLA team to track data from the field through the laboratory to the RMA data base. This tracking system will allow team members to monitor the status of specific data at any time.

The HLA team has, from past experience, established a strong working relationship with the Technology Division and Analytical Branch of USATHAMA. This working relationship allows for early identification of problems that require corrective action and rapid resolution of such problems. The Program Data Coordinator will have overall responsibility for the data by systematically updating and reviewing data processing in the IRDMS. Team members will also be trained in the use of the IRDMS and will work with the Program Data Coordinator to document the completeness of the reported data.

5.1 PROCEDURES

The HLA Data Management System (DMS) will encode maps and geotechnical and analytical data. Each data type will have specific coding forms using formats designed to meet IRDMS requirements.

Survey coordinates and elevations required to determine accurate sampling points will be measured by surveyors and will be entered into the map data base by PMO-RMA. PMO-RMA will then provide validated map location data that can be transferred to coding forms for entry to the DMS. Map records will be entered weekly or as needed.

Analytical data will be coded by the laboratories onto forms that are compatible with the IRDMS format. Sample ID numbers will be determined by the laboratory and will include:

- Unique site ID (assigned by the sampling team)
- USATHAMA sample ID number (specified in Section 9.3.2 of the USATHAMA 1985 QA Plan, revised March 1987)

Subsamples of individual analytical fractions will receive unique USATHAMA sample lot ID numbers but will retain the site ID assigned in the field. The laboratory will provide HLA with individual lot designations or analysis request forms. These forms will be reviewed by HLA to assure that sample analyses requested are consistent with the project sampling plan and project QA plan. The laboratories (Enseco-Cal, DataChem, MetaTrace, and MRI) will enter all analytical and QC data into their IRDMS computer system using software provided by USATHAMA. These data will be transmitted to the HLA DMS for verification and transmission to the IRDMS. Analytical data will be available to the Army within 55 days of sample collection.

5.2 DATA CODING

Coding requirements for the USATHAMA IRDMS are described in detail in the IRDMS User's Guide. Data to be entered into the RMA data base will be coded to meet the field and record formats of the IRDMS program. Rejection of incorrectly coded or formatted data entries will be documented by the HLA Program Data Coordinator, and corrective action required will be communicated to the laboratory or HLA data management personnel.

The most recent coding guidelines available from USATHAMA for entry of data are from the July 1988 version of the IRDMS User's Guide. Some standard file types include:

- GMA - map records
- GWC well construction - prepared for newly installed ground-water well
- GGS ground water stabilized - prepared following sampling of a well

- GFD field drilling - prepared for soil boring and well construction
- Sediment
- CSO - soil
- CGW - ground water
- CSW - surface water
- Biota
- Air

5.3 DATA FLOW

The flow of data from the field through the HLA DMS into the laboratories and finally to the RMA PM data bases will be conducted in the following sequence:

- Field samples are logged onto a chain-of-custody form
- Chain-of-custody information, including analyses requested, is entered into the HLA sample tracking system and compared with the original sampling plan
- Samples are received by the laboratory, and lot designations or analysis request forms are assigned to each sample
- Lot designations are received by HLA in 14 days, or the laboratory is notified that lot designations have not been received
- Lot designations are checked against the chain-of-custody form for accuracy and completeness
- Laboratory analytical data are coded into the IRDMS transfer files
- Data are evaluated to ensure that the data were collected under controlled conditions
- Samples that do not meet QA requirements are re-analyzed if holding times have not expired, or rejected data are grouped and qualified for later transmission to HLA
- Data that pass QA requirements are record checked and group checked using the IRDMS until all detected errors have been corrected
- Data, including accepted and qualified rejected data, are transferred to HLA via a floppy disk

- HLA informs the laboratory of any data that have been transmitted to HLA within the 35-day or project-specified reporting time
- Data received by HLA are checked for completeness and accuracy using the IRDMS until all errors have been corrected
- Transmission of data to DP Associates is performed within 55 days
- Data are entered by DP Associates to a temporary QA file
- Data are rerun through IRDMS record checks and group checks by DP Associates, and problems are corrected
- HLA reviews control chart data and recommends data to be elevated to usable- or unusable-qualified status
- HLA delivers control charts and recommendations to the PMO-RMA for final review and comment
- HLA and DP Associates are notified of data usability status
- Usable data are stored in the RMA data base
- Unusable data are stored and qualified in a separate reference data base

The sequence of data flow steps is shown in Figure 1.

Usable data become "read only" files and cannot be changed by the HLA team.

USATHAMA will be responsible for converting preliminary data to usable files. Occasionally, records need to be changed or deleted as a result of new information or corrective actions. Changing usable data requires a formal written request from the HLA Program Data Coordinator to the USATHAMA Data Coordinator. Upon approval, changes may be made to the IRDMS by USATHAMA.

Usable "read only" data will be utilized by the team for statistical manipulations, plotting, modeling, and design and for interim or final reports. The data will be retrieved from the IRDMS network via a 2400-Baud modem, and output will be distributed for use by team members using IRDMS programs.

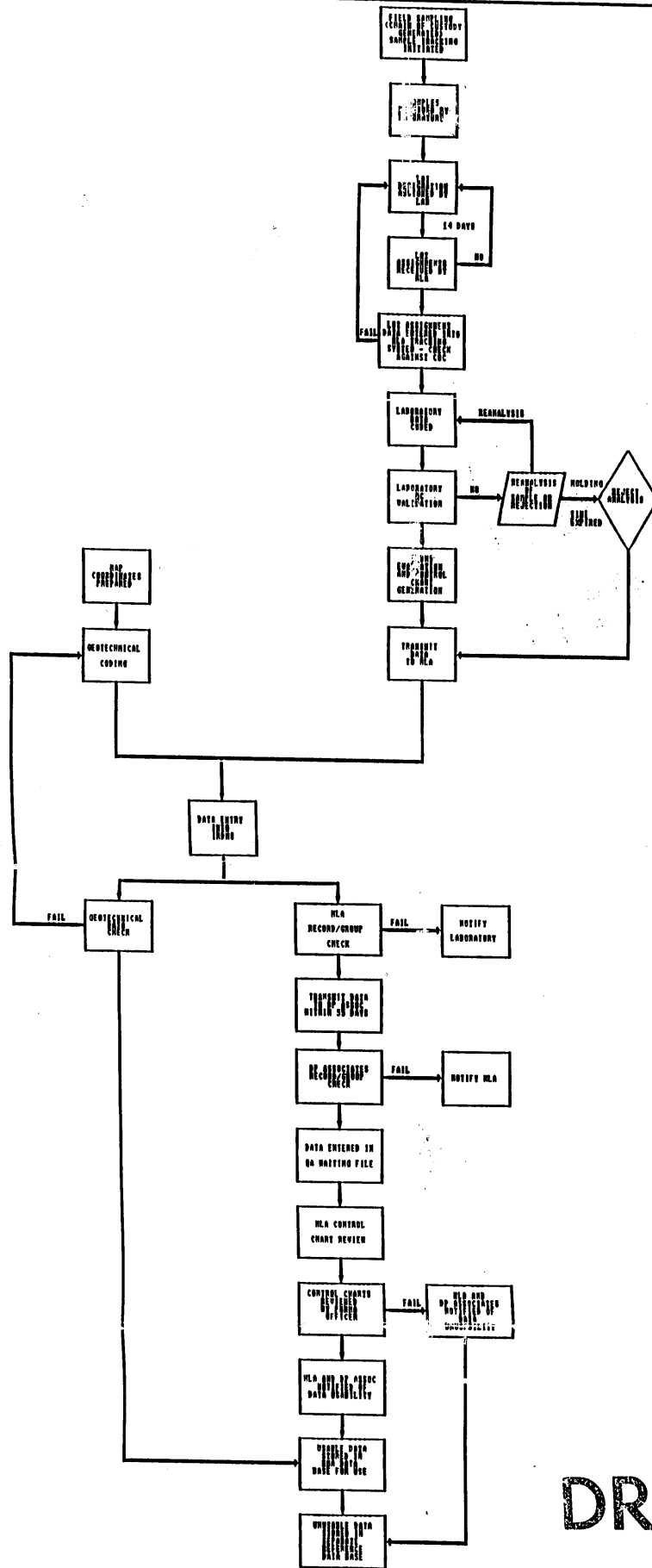

DRAFT

Prepared for:
 U.S. Army Program Manager's Office
 For Rocky Mountain Arsenal
 Aberdeen Proving Ground, Maryland

Figure 1
 RIFS-1 DATA MANAGEMENT FLOW CHART

5.4 DATA TRACKING

HLA's computerized sample and data tracking system will be utilized to monitor sample data from the time of sampling, through analysis, and through the steps of data acceptance until entry into the RMA database. The program is menu-driven and integrated with the IRDMS coding requirements. With this system, biweekly status reports for samples and data will be generated. The use of this tracking system will ensure that all analyses and samples requested for analysis are performed and that the data pass established milestones in a timely manner.

Contractual milestones for data submission to USATHAMA that can be tracked by the system include:

- Data sent to DP Associates within 55 days of sample collection
- Notification of the Contracting Officer within 5 days of elevation of data to usable status
- Timely submission of the biweekly log of sample/data status

The system has the capability to track other contract deliverables such as the delivery of lot designation to HLA within 14 days of sampling and the delivery of transfer files within 35 days of sampling.

5.5 HARDWARE AND SOFTWARE RESOURCES

The data generated during the Offpost RI/FS-1 activities will be stored on an Advanced Logic Research (ALR) IBM-compatible PC. The data will be entered in a dBase III/dBase IV format and will be tracked using the USATHAMA IRDMS and HLA's sample and data tracking system. Data output devices accessible to the ALR workstation include an Apple LazerWriter printer, a dot matrix printer, a high-speed CalComp 1043 plotter, and a 2400 Baud modem.

Other hardware resources include a local area network of three SUN Microsystems workstations and IBM or IBM-compatible PC workstations and portables. A variety of

software for data base management (dBaseIII, dBase IV, INGRES), spreadsheets (LOTUS, SYMPHONY), CAD and graphics packages (AUTOCAD Release 10, GRAPHER, and SURFER), and a statistical analysis package (SPSS) will also be used as needed for data manipulation and analysis.

DRAFT

6.0 QA/QC PROGRAM

The QA/QC program for the RI/FS-1 investigation will monitor project technical and analytical procedures to ensure that data collected are accurate, precise, representative, complete, and comparable. The QA/QC Program will conform to the 1985 USATHAMA QA Program Plan - 2nd Edition (Revised, March 1987). The HLA QA Coordinator will enforce full compliance with USATHAMA's QA policies.

The objectives of the QA/QC Program are to:

- Ensure that technically defensible and consistent field procedures are used for sample collection
- Document that appropriate procedures are used to collect, preserve, and handle samples
- Collect samples such that data accuracy, precision, representativeness, completeness, and comparability may be assessed
- Perform chemical analyses of all samples according to documented and certified procedures
- Ensure that accuracy and precision attained during the USATHAMA analytical certification program are maintained during the project
- Ensure the validity of procedures and systems used to achieve project goals
- Perform and document corrective actions that are approved and properly documented
- Quickly determine deficiencies affecting data quality
- Ensure that documentation is verified and complete

Successful completion of such a QA program is dependent on both the program organization and the methods used to control data quality. The QA function for the project is independent of technical program management. QA managers will report directly to the Program Manager. The Field QC Coordinator, Laboratory Auditor, and Laboratory QA Managers will report to the QA Coordinator.

The responsibilities and authority of the QA Coordinator include implementation of the QA Program Plan and ensuring that field and laboratory chain-of-custody and documentation procedures are enforced. In addition, the QA Coordinator will:

- Prepare and submit weekly reports of sampling and laboratory problems, control charts, and corrective actions to the Program Manager and USATHAMA
- Ensure that review responsibilities are established for all work programs and that required reviews are conducted
- Ensure that security procedures are implemented for handling samples, data, and project documents
- Ensure that laboratory QC problems are reported to the responsible Group Leader and that the problems are resolved quickly
- Reject any laboratory or field data that do not comply with program QC criteria or procedures
- Perform announced and unannounced audits of laboratory and field operations to assess implementation of the QC procedures

6.1 DATA VALIDATION

Validation of analytical data that ultimately reach usable status is the responsibility of the QA Coordinator with the support of the Program Data Coordinator and PMO-RMA. Data validation will be performed by a review and acceptance procedure at each level of data acquisition. The procedure is designed to ensure that all forms, logbooks, notebooks, and documents prepared by the team are reviewed and approved by the person preparing the document as well as a senior team member.

Coding forms or data transmitted from the laboratories must be reviewed for completeness and accuracy by the Laboratory QA Manager or designated representative prior to data submittal to the HLA Program Data Coordinator or HLA DMS. Geotechnical coding forms will be reviewed by a senior geologist and Field QA Coordinator for uniformity, completeness, and accuracy prior to submittal for data entry. All data related to USATHAMA coding will be

maintained in locking file cabinets, and the computerized files will be protected by encryption and password access.

Transcription errors will be minimized by checking the printed output of data files against the coding forms. Data and initials of the individual performing the check are part of the permanent file. As part of the audit process, the QA Coordinator will review laboratory and field data for errors in transcription, scientific validity, and traceability for litigation purposes. Should the validation process result in errors, the RI/ES-1 Task Manager will be notified to take corrective action. If the corrective action includes deleting or changing usable data, USATHAMA will be informed via a written transmittal that indicates the problem, the corrective action, and the request for change in usable data.

6.2 APPROACH TO DATA VALIDATION

Validation of field measurement data and laboratory data will be performed to ensure that data produced are of known and documented quality consistent with project DQOs. Laboratory data validation will be performed consistent with the USATHAMA Guidelines and other appropriate guidelines.

Field data validation will be performed on the basis of field QC criteria established in the QA/QC Plan. Field QC samples such as replicates, rinsates, field blanks, and trip blanks will be used to perform validation of analytical results.

6.2.1 Field Measurement Data Validation

Validation of data obtained from field measurements will be performed by the HLA QA Manager or designated representative. Validation of field data will be performed by checking procedures utilized in the field and comparing the data to previous measurements. Validation tasks will include:

- Sampling and field analytical methodology (e.g., pH, conductivity, temperature)

- Sample preservation
- Instrument selection and use
- Calibration and standardization
- Preventative and remedial maintenance of field equipment
- Replicate sampling and analysis (field parameters) in the field
- Blind, spiked (if appropriate), and rinse samples
- Trip and field blanks

6.2.2 Laboratory Analytical Data Validation

The laboratory will perform analytical data reduction and validation under the direction of the laboratory QA Officer. The laboratory QA Officer will be responsible for assessing data quality and advising appropriate Section Supervisors and HLA's QA Manager of data that are rated "preliminary" or "unacceptable" or other notations that would caution the data user of possible unreliability. Data reduction, validation, and reporting by the laboratory will be conducted as follows:

- Raw data produced by the analyst will be submitted to the respective Section Supervisor
- The Section Supervisor will review the data for attainment of QC criteria as outlined in the established USA/HAMA methods.
- Upon acceptance of the raw data by the Section Supervisor, a computerized report will be generated and will be submitted to the laboratory QA Officer
- The laboratory QA Officer will complete a thorough audit of all reports for consistency
- The laboratory QA Officer and Section Supervisor will determine whether sample re-analysis is required
- Upon acceptance of the preliminary reports by the QA Officer, transfer files will be generated and forwarded to HLA

The laboratory QA Manager will conduct an evaluation of data reduction and reporting by the laboratory. These evaluations will consider the transfer or coding files, calculation sheets, document control forms, blank data, duplicate data, and recovery data for QA samples. The material will be checked for legibility, completeness, correctness, and the presence of necessary dates, initials, and signatures. Assessment of analytical data by HLA will also include checks for data consistency by assessing comparability of duplicate analyses, comparability to previous data from the same sampling location (if available), adherence to accuracy and precision criteria, transmittal errors, and anomalous high or low parameter values. The results of these checks will be assessed and reported to HLA's Project Manager and PMO-RMA, noting any discrepancies and their effect on the ultimate acceptability of the data.

The following is a brief description of validation steps that will be used by HLA's Data Manager or designated representative to independently validate the laboratory data. Consistent with USATHAMA functional guidelines for data validation, these checks will be performed on 100 percent of all samples analyzed and the results will be summarized in a report to the project QA Coordinator. Validation steps are as follows:

- Compile a list of all investigative samples and sample lots received
- Compile a list of all QC samples, including
 - o Field blanks
 - o Trip blanks
 - o Laboratory blanks
 - o Laboratory duplicates
 - o Performance QC samples
- Review chain-of-custody records
- Prepare a data summary that includes:

- Results
- Sample media identification
- Sample location and descriptions
- Appropriate concentration units
- Appropriate significant figures

This data summary will be reviewed for potential data quality problems, including:

- Unexpected results
- Common laboratory contaminants
- Unusual spatial concentration/identification relationships
- Unexpected compound or parameter relationships
- Sample in which dilution was necessary

A sample summary will be prepared to assess precision, accuracy, representativeness, completeness, and comparability of the analytical data.

Despite all efforts to achieve the objectives of the project, the potential for error exists in laboratory chemical analyses and in the data reporting process. Every reasonable effort will be made to compare and double-check data reported from the laboratory, data entered into the DMSs, and data subsequently reported in accordance with the USATHAMA QA Program Plan.

7.0 DOCUMENT CONTROL SYSTEM

The document control system applies to the incoming, outgoing, and internal project technical documents identified on the Project Document Types List. The documents are processed by the document control function, which includes receiving/sending, reproducing, distributing, indexing, filing, retrieving documents for project reference, retaining documents for HLA, and relinquishing documents to the client as contractually required. The mail/reproduction function supports the document control system by receiving, producing, and mailing/delivering documents as appropriate.

7.1 DEFINITIONS

Corporate Record Copy is the copy of the project document that is forwarded to the Novato Records Center according to HLA corporate procedures (hard copy or long-term storage medium such as microfilm).

Document Control File Number is a unique, sequential document control number assigned to every document received or issued by the project.

Document Control System is a system governing the administrative processing and control of project documents. Processing includes receiving/issuing, distributing, filing centrally, indexing, retrieving copies from the working file, and retaining a master file copy.

Master File Copy is the completed original or best copy of a project technical document that is processed into the document control system and retained in the Project Master File.

Project Master File is the centrally controlled secure collection of a project's technical documents and attachments. The documents in each project master file are filed in order of their sequentially assigned document control file number. Documents in the project master file may be organized into separate file collections such as general, correspondence, field documents, and library/reference documents. The project master file is accessible to

authorized employees only and is not used for day-to-day reference by project personnel. The project master file is retained to meet HLA's long-term retention requirements. It may be converted to a medium more suitable for long-term retention such as microfilm.

Project Technical Documents include the following:

- Correspondence related to the project, such as transmittals, letters, interoffice memoranda, telephone confirmations, meeting minutes, telecopies, scope changes, and job setup sheets
- Field documents such as chain-of-custody records, field inspection reports, chemical data sheets, well sheets, and boring logs
- Reports such as HLA reports (bound or letter format), EPA guidance documents, and other technical references
- Other types of documents identified by the project manager as listed on the Document Types List

Working Copy is a copy of the project document that has been processed in the document control system and is designated for the working file. The working copy is used by individuals on the project to perform their immediate tasks.

Working File contains the working copies as needed by project personnel on a routine basis to do their work. The working file is maintained in an area most accessible to project personnel using the file and in a file order that responds to project tasks, e.g., by job number, task, or responsible individuals. The working file is retained temporarily by the project manager for easy retrieval and reproduction of documents until the work is completed. The collection is then released as directed by the project manager.

7.2 PROCEDURE

The project manager and the document control supervisor review the following information:

- Regulatory requirements governing the work
- Contract records retention and relinquishment requirements

- Project schedule and staffing
- Project deliverables and the volume of documents estimated to be generated or received by the project
- Document Types List

This review provides the following information that establishes the scope of the document control system:

- Project-specific Document Types List
- Project individuals responsible for providing field documents to the document control function
- Project distribution requirements
- Project plan for relinquishment of contractually required records to the client
- Manual or automated project document control indexing requirements, if any
- Project master file configuration (separate collections for general correspondence, field documents, library-type documents)
- Project working file contents and file sequence

7.2.1 Incoming Documents

The mail/reproduction function receives and date stamps all incoming documents addressed to HLA personnel (including teletypes). Project-related documents are delivered to the document control function and copies of teletypes and personal mail to the addressees

The document control function processes the incoming documents as follows:

- Sorts the documents and assembles them into collections by project. This includes all teletypes, overnight deliveries, and hand deliveries that arrive in the office.
- Checks each document and its attachments to verify that it contains the contents indicated and is of adequate quality to be reproduced. Notifies the project manager if there is a problem and takes corrective action to resolve the problem.
- Identifies the project master file for the document (correspondence, reports, contracts) and notes it on the document. If this information is not apparent, the addressee must will be asked to make a determination.

- Determines the next document control file number for the project master file collection from the file number assignment log. Writes the date and a brief document description on the log to control the assignment of the file numbers.
- Stamps the document control file number on the original document and, if applicable, on the first and last pages of the attachment(s).
- Applies a distribution stamp/form to the document.
- Indicates the distribution on the distribution stamp.
- Enters document information into the document control index (manual or automated).
- Files the original document in the appropriate master file collection; if attachments are filed in another project master file collection, specifies the name of the other file on the original document.

7.2.2 Outgoing Documents

The mail/reproduction function receives all outgoing and internal project-related documents. These documents will be prepared according to HLA procedures. In addition, the Document Control Number will be the last item within the subject line. The originator of the outgoing document is responsible for coordinating with Document Control to obtain the Document Control Number before turning the document into Word Processing. Outgoing documents will be processed as follows:

- Documents are reproduced according to distribution information
- Original document and outgoing copies are placed in the outgoing mail
- Remaining copies are delivered to the document control function

The document control function continues processing as follows:

- Determines the next document control file number for the project master file collection from the file number assignment log. Writes the date and a brief document descriptions on the log to control the assignment of the file numbers
- Stamps the document file number on the original document and, if applicable, on the first and last pages of the attachment(s)

- Files the original document in the appropriate master file collection; if attachments are filed in another project master file collection, specifies the name of the other file on the original document

7.2.3 HLA Retention Policy

The document control function is the custodian of the closed project master files in the Denver Office. These files are maintained according to HLA's corporate procedures on retention of closed project files (archives/retain inventory).

DRAFT

LIST OF REFERENCES

U.S. Army Toxic and Hazardous Materials Agency, December 1985 (2nd Edition, March 1987).
USATHAMA QA Program, Aberdeen Proving Ground, Maryland.

HLA, Offpost Interim Response Action, Draft Quality Assurance Plan, March 1989, Contract #
DAAA15-88D-0021/0001 RI/FS-1.

Potomac Research, Inc., July 1988, The Installation Restoration Data Management System for
the IBM PC/XT or PC/AT, prepared for U.S. Army Toxic and Hazardous Materials Agency,
Aberdeen Proving Ground, Maryland.

DRAFT

DRAFT

Appendix A

**HARDING LAWSON ASSOCIATES
FIELD FORMS**



Harding Lawson Associates
Engineers and Geoscientists

GROUND-WATER SAMPLING FORM

Job Name _____
Job Number _____
Recorded by _____
(Signature)

Well No. _____
Well Type: Monitor Extraction Other _____
Well Material: PVC St. Steel Other _____
Date _____ Time _____
Sampled by _____
(Print Name)

WELL PURGING

PURGE VOLUME

Casing Diameter (D in inches):
 2-inch 4-inch 6-inch Other _____
Total Depth of Casing (TD in feet BTOC): _____
Water Level Depth (WL in feet BTOC): _____
Number of Well Volumes to be purged (# Vols):
 3 4 5 10 Other _____

PURGE METHOD

Bailor - Type: _____
 Submersible Centrifugal Bladder; Pump No.: _____
 Other - Type: _____

PUMP INTAKE SETTING

Near Bottom Near Top Other _____
Depth in feet (BTOC): _____ Screen Interval in feet (BTOC):
from _____ to _____

PURGE VOLUME CALCULATION:

$$\left(\frac{TD \text{ (feet)} - WL \text{ (feet)}}{D \text{ (inches)}} \right)^2 \times \# \text{ Vols} \times 0.0408 = \text{Calculated Purge Volume (gallons)}$$

PURGE TIME:

Start _____ Stop _____Elapsed _____

PURGE RATE:

Initial _____ gpm Final _____ gpm

ACTUAL PURGE VOLUME:

_____ gallons

FIELD PARAMETER MEASUREMENT:

Minutes Since Pumping Began	pH	Cond. (µmhos/cm)	T °C / °F	Other

Minutes Since Pumping Began	pH	Cond. (µmhos/cm)	T °C / °F	Other

Meter Nos. _____

Observations During Purging (Well Condition, Turbidity, Color, etc.): _____
Discharge Water Disposed: Sanitary Sewer Storm Sewer Other _____

WELL SAMPLING

SAMPLING METHOD

Bailor - Type: _____
 Submersible Centrifugal Bladder; Pump No.: _____
 Same As Above Grab - Type: _____
 Other - Type: _____

SAMPLE DISTRIBUTION

Sample No.	Volume/Cont.	Analysis Requested	Preservatives	Lab	Comments

QUALITY CONTROL SAMPLES

Duplicate Samples		Blank Samples		Other Samples	
Original Sample No.	Duplicate Sample No.	Type	Sample No.	Type	Sample No.

Prepared for:
U.S. Army Program Manager's Office
For Rocky Mountain Arsenal
Aberdeen Proving Ground, Maryland

Site ID:	 Harding Lawson Associates 1501 Pennsylvania St. Suite 200 Denver, CO 80203 303/894-9878			
Site Type:				
Sample Tech:	<table border="1"> <tr> <td>Analysis</td> <td>Container</td> <td>Preservative</td> </tr> </table>	Analysis	Container	Preservative
Analysis	Container	Preservative		
Depth (cm):	Remarks:			
Date:				
Time:	Sampler Signature:	Tag No.:		

DRAFT

Prepared for:
 U.S. Army Program Manager's Office
 For Rocky Mountain Arsenal
 Aberdeen Proving Ground, Maryland

WATERS/LIQUIDS SAMPLE LABEL

ANALYSES REQUESTED	TAG NO:	SITE IDENTIFICATION:
	SITE TYPE:	REMARKS:
	DATE:	
	DEPTH (CM):	
(Signatures)	TECHNIQUE: G	HARDING LAWSON ASSOCIATES ENGINEERS, GEOLOGISTS & GEOPHYSICISTS  1301 Pennsylvania St. Suite 200 Denver, CO 80203 303/894-9878

DRAFT

Prepared for:
 U.S. Army Program Manager's Office
 For Rocky Mountain Arsenal
 Aberdeen Proving Ground, Maryland

SOILS/SOLIDS SAMPLE LABEL

**HAZARDOUS SUBSTANCE
SOLID OR LIQUID NOS
HARDING LAWSON ASSOCIATES
DENVER, COLORADO
(303) 894-9878**

ORM-E

NA 9188

DRY

**Prepared for:
U.S. Army Program Manager's Office
For Rocky Mountain Arsenal
Aberdeen Proving Ground, Maryland**

**WARNING LABEL FOR SAMPLE
SHIPMENT**

FEDEX
Express

AIRBILL
SEE THIS AIRBILL FOR SHIPPING CHARGES TO WHICH THE CARRIER'S U.S.A., ALASKA AND CANADA. SEE THE AIRBILL FOR THE CARRIER'S U.S.A., ALASKA AND CANADA. FREIGHT CALL 800-244-8255 FOR RATE.

TRACKING NUMBER **8643306545**

8159H **8643306545**

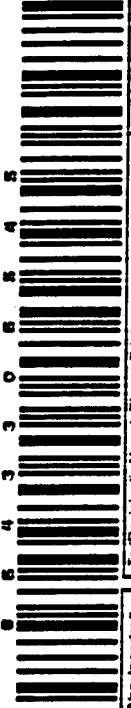

7071
8885

Sender's Federal Express Account Number **1196-2034-1**
 From (Your Name) Please Print
 Company **HARDING LAMSON ASSOC**
 Street Address **1301 PENNSYLVANIA STE 200**
 City **DENVER** State **CO** ZIP Required **80203**
 Department/Floor No.
 Your Phone Number (Very Important) () ()
 Department/Floor No.
 To (Recipient's Name) Please Print
 Company
 Exact Street Address (We Cannot Deliver to P.O. Boxes or P.O. Zip Codes)
 City State ZIP Required

YOUR BILLING REFERENCE INFORMATION (FIRST 24 CHARACTERS WILL APPEAR ON INVOICE)

DELIVERY AND SPECIAL HANDLING

1 **OVERNIGHT DELIVERY** 6 **OVERNIGHT LETTERS**

2 **COMMERCIAL DELIVERY** 7 **DELIVER WEEKDAY**

3 **DELIVER SATURDAY** 8 **DELIVER SUNDAY**

4 **DELIVER MONDAY** 9 **DELIVER TUESDAY**

5 **DELIVER WEDNESDAY** 10 **DELIVER THURSDAY**

6 **DELIVER FRIDAY** 11 **DELIVER SATURDAY**

7 **DELIVER SUNDAY** 12 **DELIVER MONDAY**

8 **DELIVER TUESDAY** 9 **DELIVER WEDNESDAY**

9 **DELIVER THURSDAY** 10 **DELIVER FRIDAY**

10 **DELIVER SATURDAY** 11 **DELIVER SUNDAY**

11 **DELIVER MONDAY** 12 **DELIVER TUESDAY**

12 **DELIVER WEDNESDAY** 13 **DELIVER THURSDAY**

13 **DELIVER FRIDAY** 14 **DELIVER SATURDAY**

14 **DELIVER SUNDAY** 15 **DELIVER MONDAY**

15 **DELIVER TUESDAY** 16 **DELIVER WEDNESDAY**

16 **DELIVER THURSDAY** 17 **DELIVER FRIDAY**

17 **DELIVER SATURDAY** 18 **DELIVER SUNDAY**

18 **DELIVER MONDAY** 19 **DELIVER TUESDAY**

19 **DELIVER WEDNESDAY** 20 **DELIVER THURSDAY**

20 **DELIVER FRIDAY** 21 **DELIVER SATURDAY**

21 **DELIVER SUNDAY** 22 **DELIVER MONDAY**

22 **DELIVER TUESDAY** 23 **DELIVER WEDNESDAY**

23 **DELIVER THURSDAY** 24 **DELIVER FRIDAY**

24 **DELIVER SATURDAY** 25 **DELIVER SUNDAY**

25 **DELIVER MONDAY** 26 **DELIVER TUESDAY**

26 **DELIVER WEDNESDAY** 27 **DELIVER THURSDAY**

27 **DELIVER FRIDAY** 28 **DELIVER SATURDAY**

28 **DELIVER SUNDAY** 29 **DELIVER MONDAY**

29 **DELIVER TUESDAY** 30 **DELIVER WEDNESDAY**

30 **DELIVER THURSDAY** 31 **DELIVER FRIDAY**

31 **DELIVER SATURDAY** 32 **DELIVER SUNDAY**

32 **DELIVER MONDAY** 33 **DELIVER TUESDAY**

33 **DELIVER WEDNESDAY** 34 **DELIVER THURSDAY**

34 **DELIVER FRIDAY** 35 **DELIVER SATURDAY**

35 **DELIVER SUNDAY** 36 **DELIVER MONDAY**

36 **DELIVER TUESDAY** 37 **DELIVER WEDNESDAY**

37 **DELIVER THURSDAY** 38 **DELIVER FRIDAY**

38 **DELIVER SATURDAY** 39 **DELIVER SUNDAY**

39 **DELIVER MONDAY** 40 **DELIVER TUESDAY**

40 **DELIVER WEDNESDAY** 41 **DELIVER THURSDAY**

41 **DELIVER FRIDAY** 42 **DELIVER SATURDAY**

42 **DELIVER SUNDAY** 43 **DELIVER MONDAY**

43 **DELIVER TUESDAY** 44 **DELIVER WEDNESDAY**

44 **DELIVER THURSDAY** 45 **DELIVER FRIDAY**

45 **DELIVER SATURDAY** 46 **DELIVER SUNDAY**

46 **DELIVER MONDAY** 47 **DELIVER TUESDAY**

47 **DELIVER WEDNESDAY** 48 **DELIVER THURSDAY**

48 **DELIVER FRIDAY** 49 **DELIVER SATURDAY**

49 **DELIVER SUNDAY** 50 **DELIVER MONDAY**

50 **DELIVER TUESDAY** 51 **DELIVER WEDNESDAY**

51 **DELIVER THURSDAY** 52 **DELIVER FRIDAY**

52 **DELIVER SATURDAY** 53 **DELIVER SUNDAY**

53 **DELIVER MONDAY** 54 **DELIVER TUESDAY**

54 **DELIVER WEDNESDAY** 55 **DELIVER THURSDAY**

55 **DELIVER FRIDAY** 56 **DELIVER SATURDAY**

56 **DELIVER SUNDAY** 57 **DELIVER MONDAY**

57 **DELIVER TUESDAY** 58 **DELIVER WEDNESDAY**

58 **DELIVER THURSDAY** 59 **DELIVER FRIDAY**

59 **DELIVER SATURDAY** 60 **DELIVER SUNDAY**

60 **DELIVER MONDAY** 61 **DELIVER TUESDAY**

61 **DELIVER WEDNESDAY** 62 **DELIVER THURSDAY**

62 **DELIVER FRIDAY** 63 **DELIVER SATURDAY**

63 **DELIVER SUNDAY** 64 **DELIVER MONDAY**

64 **DELIVER TUESDAY** 65 **DELIVER WEDNESDAY**

65 **DELIVER THURSDAY** 66 **DELIVER FRIDAY**

66 **DELIVER SATURDAY** 67 **DELIVER SUNDAY**

67 **DELIVER MONDAY** 68 **DELIVER TUESDAY**

68 **DELIVER WEDNESDAY** 69 **DELIVER THURSDAY**

69 **DELIVER FRIDAY** 70 **DELIVER SATURDAY**

70 **DELIVER SUNDAY** 71 **DELIVER MONDAY**

71 **DELIVER TUESDAY** 72 **DELIVER WEDNESDAY**

72 **DELIVER THURSDAY** 73 **DELIVER FRIDAY**

73 **DELIVER SATURDAY** 74 **DELIVER SUNDAY**

74 **DELIVER MONDAY** 75 **DELIVER TUESDAY**

75 **DELIVER WEDNESDAY** 76 **DELIVER THURSDAY**

76 **DELIVER FRIDAY** 77 **DELIVER SATURDAY**

77 **DELIVER SUNDAY** 78 **DELIVER MONDAY**

78 **DELIVER TUESDAY** 79 **DELIVER WEDNESDAY**

79 **DELIVER THURSDAY** 80 **DELIVER FRIDAY**

80 **DELIVER SATURDAY** 81 **DELIVER SUNDAY**

81 **DELIVER MONDAY** 82 **DELIVER TUESDAY**

82 **DELIVER WEDNESDAY** 83 **DELIVER THURSDAY**

83 **DELIVER FRIDAY** 84 **DELIVER SATURDAY**

84 **DELIVER SUNDAY** 85 **DELIVER MONDAY**

85 **DELIVER TUESDAY** 86 **DELIVER WEDNESDAY**

86 **DELIVER THURSDAY** 87 **DELIVER FRIDAY**

87 **DELIVER SATURDAY** 88 **DELIVER SUNDAY**

88 **DELIVER MONDAY** 89 **DELIVER TUESDAY**

89 **DELIVER WEDNESDAY** 90 **DELIVER THURSDAY**

90 **DELIVER FRIDAY** 91 **DELIVER SATURDAY**

91 **DELIVER SUNDAY** 92 **DELIVER MONDAY**

92 **DELIVER TUESDAY** 93 **DELIVER WEDNESDAY**

93 **DELIVER THURSDAY** 94 **DELIVER FRIDAY**

94 **DELIVER SATURDAY** 95 **DELIVER SUNDAY**

95 **DELIVER MONDAY** 96 **DELIVER TUESDAY**

96 **DELIVER WEDNESDAY** 97 **DELIVER THURSDAY**

97 **DELIVER FRIDAY** 98 **DELIVER SATURDAY**

98 **DELIVER SUNDAY** 99 **DELIVER MONDAY**

99 **DELIVER TUESDAY** 100 **DELIVER WEDNESDAY**

100 **DELIVER THURSDAY** 101 **DELIVER FRIDAY**

101 **DELIVER SATURDAY** 102 **DELIVER SUNDAY**

102 **DELIVER MONDAY** 103 **DELIVER TUESDAY**

103 **DELIVER WEDNESDAY** 104 **DELIVER THURSDAY**

104 **DELIVER FRIDAY** 105 **DELIVER SATURDAY**

105 **DELIVER SUNDAY** 106 **DELIVER MONDAY**

106 **DELIVER TUESDAY** 107 **DELIVER WEDNESDAY**

107 **DELIVER THURSDAY** 108 **DELIVER FRIDAY**

108 **DELIVER SATURDAY** 109 **DELIVER SUNDAY**

109 **DELIVER MONDAY** 110 **DELIVER TUESDAY**

110 **DELIVER WEDNESDAY** 111 **DELIVER THURSDAY**

111 **DELIVER FRIDAY** 112 **DELIVER SATURDAY**

112 **DELIVER SUNDAY** 113 **DELIVER MONDAY**

113 **DELIVER TUESDAY** 114 **DELIVER WEDNESDAY**

114 **DELIVER THURSDAY** 115 **DELIVER FRIDAY**

115 **DELIVER SATURDAY** 116 **DELIVER SUNDAY**

116 **DELIVER MONDAY** 117 **DELIVER TUESDAY**

117 **DELIVER WEDNESDAY** 118 **DELIVER THURSDAY**

118 **DELIVER FRIDAY** 119 **DELIVER SATURDAY**

119 **DELIVER SUNDAY** 120 **DELIVER MONDAY**

120 **DELIVER TUESDAY** 121 **DELIVER WEDNESDAY**

121 **DELIVER THURSDAY** 122 **DELIVER FRIDAY**

122 **DELIVER SATURDAY** 123 **DELIVER SUNDAY**

123 **DELIVER MONDAY** 124 **DELIVER TUESDAY**

124 **DELIVER WEDNESDAY** 125 **DELIVER THURSDAY**

125 **DELIVER FRIDAY** 126 **DELIVER SATURDAY**

126 **DELIVER SUNDAY** 127 **DELIVER MONDAY**

127 **DELIVER TUESDAY** 128 **DELIVER WEDNESDAY**

128 **DELIVER THURSDAY** 129 **DELIVER FRIDAY**

129 **DELIVER SATURDAY** 130 **DELIVER SUNDAY**

130 **DELIVER MONDAY** 131 **DELIVER TUESDAY**

131 **DELIVER WEDNESDAY** 132 **DELIVER THURSDAY**

132 **DELIVER FRIDAY** 133 **DELIVER SATURDAY**

133 **DELIVER SUNDAY** 134 **DELIVER MONDAY**

134 **DELIVER TUESDAY** 135 **DELIVER WEDNESDAY**

135 **DELIVER THURSDAY** 136 **DELIVER FRIDAY**

136 **DELIVER SATURDAY** 137 **DELIVER SUNDAY**

137 **DELIVER MONDAY** 138 **DELIVER TUESDAY**

138 **DELIVER WEDNESDAY** 139 **DELIVER THURSDAY**

139 **DELIVER FRIDAY** 140 **DELIVER SATURDAY**

140 **DELIVER SUNDAY** 141 **DELIVER MONDAY**

141 **DELIVER TUESDAY** 142 **DELIVER WEDNESDAY**

142 **DELIVER THURSDAY** 143 **DELIVER FRIDAY**

143 **DELIVER SATURDAY** 144 **DELIVER SUNDAY**

144 **DELIVER MONDAY** 145 **DELIVER TUESDAY**

145 **DELIVER WEDNESDAY** 146 **DELIVER THURSDAY**

146 **DELIVER FRIDAY** 147 **DELIVER SATURDAY**

147 **DELIVER SUNDAY** 148 **DELIVER MONDAY**

148 **DELIVER TUESDAY** 149 **DELIVER WEDNESDAY**

149 **DELIVER THURSDAY** 150 **DELIVER FRIDAY**

150 **DELIVER SATURDAY** 151 **DELIVER SUNDAY**

151 **DELIVER MONDAY** 152 **DELIVER TUESDAY**

152 **DELIVER WEDNESDAY** 153 **DELIVER THURSDAY**

153 **DELIVER FRIDAY** 154 **DELIVER SATURDAY**

154 **DELIVER SUNDAY** 155 **DELIVER MONDAY**

155 **DELIVER TUESDAY** 156 **DELIVER WEDNESDAY**

156 **DELIVER THURSDAY** 157 **DELIVER FRIDAY**

157 **DELIVER SATURDAY** 158 **DELIVER SUNDAY**

158 **DELIVER MONDAY** 159 **DELIVER TUESDAY**

159 **DELIVER WEDNESDAY** 160 **DELIVER THURSDAY**

160 **DELIVER FRIDAY** 161 **DELIVER SATURDAY**

161 **DELIVER SUNDAY** 162 **DELIVER MONDAY**

162 **DELIVER TUESDAY** 163 **DELIVER WEDNESDAY**

163 **DELIVER THURSDAY** 164 **DELIVER FRIDAY**

164 **DELIVER SATURDAY** 165 **DELIVER SUNDAY**

165 **DELIVER MONDAY** 166 **DELIVER TUESDAY**

166 **DELIVER WEDNESDAY** 167 **DELIVER THURSDAY**

167 **DELIVER FRIDAY** 168 **DELIVER SATURDAY**

168 **DELIVER SUNDAY** 169 **DELIVER MONDAY**

169 **DELIVER TUESDAY** 170 **DELIVER WEDNESDAY**

170 **DELIVER THURSDAY** 171 **DELIVER FRIDAY**

171 **DELIVER SATURDAY** 172 **DELIVER SUNDAY**

172 **DELIVER MONDAY** 173 **DELIVER TUESDAY**

173 **DELIVER WEDNESDAY** 174 **DELIVER THURSDAY**

174 **DELIVER FRIDAY** 175 **DELIVER SATURDAY**

175 **DELIVER SUNDAY** 176 **DELIVER MONDAY**

176 **DELIVER TUESDAY** 177 **DELIVER WEDNESDAY**

177 **DELIVER THURSDAY** 178 **DELIVER FRIDAY**

178 **DELIVER SATURDAY** 179 **DELIVER SUNDAY**

179 **DELIVER MONDAY** 180 **DELIVER TUESDAY**

180 **DELIVER WEDNESDAY** 181 **DELIVER THURSDAY**

181 **DELIVER FRIDAY** 182 **DELIVER SATURDAY**

182 **DELIVER SUNDAY** 183 **DELIVER MONDAY**

183 **DELIVER TUESDAY** 184 **DELIVER WEDNESDAY**

184 **DELIVER THURSDAY** 185 **DELIVER FRIDAY**

185 **DELIVER SATURDAY** 186 **DELIVER SUNDAY**

186 **DELIVER MONDAY** 187 **DELIVER TUESDAY**

187 **DELIVER WEDNESDAY** 188 **DELIVER THURSDAY**

188 **DELIVER FRIDAY** 189 **DELIVER SATURDAY**

189 **DELIVER SUNDAY** 190 **DELIVER MONDAY**

190 **DELIVER TUESDAY** 191 **DELIVER WEDNESDAY**

191 **DELIVER THURSDAY** 192 **DELIVER FRIDAY**

192 **DELIVER SATURDAY** 193 **DELIVER SUNDAY**

193 **DELIVER MONDAY** 194 **DELIVER TUESDAY**

194 **DELIVER WEDNESDAY** 195 **DELIVER THURSDAY**

195 **DELIVER FRIDAY** 196 **DELIVER SATURDAY**

196 **DELIVER SUNDAY** 197 **DELIVER MONDAY**

197 **DELIVER TUESDAY** 198 **DELIVER WEDNESDAY**

198 **DELIVER THURSDAY** 199 **DELIVER FRIDAY**

199 **DELIVER SATURDAY** 200 **DELIVER SUNDAY**

200 **DELIVER MONDAY** 201 **DELIVER TUESDAY**

201 **DELIVER WEDNESDAY** 202 **DELIVER THURSDAY**

202 **DELIVER FRIDAY** 203 **DELIVER SATURDAY**

203 **DELIVER SUNDAY** 204 **DELIVER MONDAY**

204 **DELIVER TUESDAY** 205 **DELIVER WEDNESDAY**

205 **DELIVER THURSDAY** 206 **DELIVER FRIDAY**

206 **DELIVER SATURDAY** 207 **DELIVER SUNDAY**

207 **DELIVER MONDAY** 208 **DELIVER TUESDAY**

208 **DELIVER WEDNESDAY** 209 **DELIVER THURSDAY**

209 **DELIVER FRIDAY** 210 **DELIVER SATURDAY**

210 **DELIVER SUNDAY** 211 **DELIVER MONDAY**

211 **DELIVER TUESDAY** 212 **DELIVER WEDNESDAY**

212 **DELIVER THURSDAY** 213 **DELIVER FRIDAY**

213 **DELIVER SATURDAY** 214 **DELIVER SUNDAY**

214 **DELIVER MONDAY** 215 **DELIVER TUESDAY**

215 **DELIVER WEDNESDAY** 216 **DELIVER THURSDAY**

216 **DELIVER FRIDAY** 217 **DELIVER SATURDAY**

217 **DELIVER SUNDAY** 218 **DELIVER MONDAY**

218 **DELIVER TUESDAY** 219 **DELIVER WEDNESDAY**

219 **DELIVER THURSDAY** 220 **DELIVER FRIDAY**

220 **DELIVER SATURDAY** 221 **DELIVER SUNDAY**

221 **DELIVER MONDAY** 222 **DELIVER TUESDAY**

222 **DELIVER WEDNESDAY** 223 **DELIVER THURSDAY**

223 **DELIVER FRIDAY** 224 **DELIVER SATURDAY**

224 **DELIVER SUNDAY** 225 **DELIVER MONDAY**

225 **DELIVER TUESDAY** 226 **DELIVER WEDNESDAY**

226 **DELIVER THURSDAY** 227 **DELIVER FRIDAY**

227 **DELIVER SATURDAY** 228 **DELIVER SUNDAY**

228 **DELIVER MONDAY** 229 **DELIVER TUESDAY**

229 **DELIVER WEDNESDAY** 230 **DELIVER THURSDAY**

230 **DELIVER FRIDAY** 231 **DELIVER SATURDAY**

231 **DELIVER SUNDAY** 232 **DELIVER MONDAY**

232 **DELIVER TUESDAY** 233 **DELIVER WEDNESDAY**

233 **DELIVER THURSDAY** 234 **DELIVER FRIDAY**

234 **DELIVER SATURDAY** 235 **DELIVER SUNDAY**

235 **DELIVER MONDAY** 236 **DELIVER TUESDAY**

236 **DELIVER WEDNESDAY** 237 **DELIVER THURSDAY**

237 **DELIVER FRIDAY** 238 **DELIVER SATURDAY**

238 **DELIVER SUNDAY** 239 **DELIVER MONDAY**

239 **DELIVER TUESDAY** 240 **DELIVER WEDNESDAY**

240 **DELIVER THURSDAY** 241 **DELIVER FRIDAY**

241 **DELIVER SATURDAY** 242 **DELIVER SUNDAY**

242 **DELIVER MONDAY** 243 **DELIVER TUESDAY**

243 **DELIVER WEDNESDAY** 244 **DELIVER THURSDAY**

244 **DELIVER FRIDAY** 245 **DELIVER SATURDAY**

245 **DELIVER SUNDAY** 246 **DELIVER MONDAY**

246 **DELIVER TUESDAY** 247 **DELIVER WEDNESDAY**

247 **DELIVER THURSDAY** 248 **DELIVER FRIDAY**

248 **DELIVER SATURDAY** 249 **DELIVER SUNDAY**

249 **DELIVER MONDAY** 250 **DELIVER TUESDAY**

250 **DELIVER WEDNESDAY** 251 **DELIVER THURSDAY**

251 **DELIVER FRIDAY** 252 **DELIVER SATURDAY**

252 **DELIVER SUNDAY** 253 **DELIVER MONDAY**

253 **DELIVER TUESDAY** 254 **DELIVER WEDNESDAY**

254 **DELIVER THURSDAY** 255 **DELIVER FRIDAY**

255 **DELIVER SATURDAY** 256 **DELIVER SUNDAY**

256 **DELIVER MONDAY** 257 **DELIVER TUESDAY**

257 **DELIVER WEDNESDAY** 258 **DELIVER THURSDAY**

258 **DELIVER FRIDAY** 259 **DELIVER SATURDAY**

FIELD LOG OF BORING

SHEET _____ OF _____

LOCATION OF BORING:

PROJECT:		BORING NO.
		TOTAL DEPTH:
JOB NO.:	LOGGED BY:	
PROJ. MGR.:	EDITED BY:	
DRILLING CONTRACTOR:		
DRILL RIG TYPE:		
DRILLERS NAME:		
SAMPLING METHODS:		
HAMMER WT.:	DROP:	
STARTED, TIME:	DATE:	
COMPLETED, TIME:	DATE:	
BORING DEPTH (ft.)		
CASING DEPTH (ft.)		
WATER DEPTH (ft.)		
TIME:		
DATE:		
BACKFILLED, TIME:	DATE:	BY:
SURFACE ELEV.:	DATUM:	
CONDITIONS:		

SAMPLE DEPTH	SAMPLER TYPE	BLOWS / 6 - IN.	INCHES DRIVEN	INCHES RECOVERED	SAMPLE CONDITION	DRILLING RATE (min/ft)	DEPTH IN FEET
							1
							2
							3
							4
							5
							6
							7
							8
							9
							10

GRAPHIC LOG

FP7

HARDING-LAWSON ASSOCIATES

Prepared for:
 U.S. Army Program Manager's Office
 For Rocky Mountain Arsenal
 Aberdeen Proving Ground, Maryland

FIELD LOG OF BORING

FIELD LOG OF BORING (CONTINUED)

SHEET _____ OF _____

DEPTH	TYPE	BLOWS	DRIVEN	REC'D	COND	D RATE		DEPTH	GRAPHIC LOG	PROJECT:	NO	BORING NO.
								1				
								2				
								3				
								4				
								5				
								6				
								7				
								8				
								9				
								0				
								1				
								2				
								3				
								4				
								5				
								6				
								7				
								8				
								9				
								0				

ROCKY MOUNTAIN ARSENAL

PPS

HARDING LAWSON ASSOCIATES

Prepared for:
 U.S. Army Program Manager's Office
 For Rocky Mountain Arsenal
 Aberdeen Proving Ground, Maryland

FIELD LOG OF BORING

FIELD WELL COMPLETION FORM

JOB NAME: _____

JOB NUMBER: _____ PROJECT MANAGER: _____

LOGGED BY: _____ EDITED BY: _____

WELL NAME: _____ DATE: _____

DRILLING COMPANY: _____

EQUIPMENT: _____ INCH HOLLOW STEM AUGER DRILLER: _____

_____ INCH ROTARY WASH HOURS DRILLED: _____

GALLONS OF WATER USED DURING DRILLING: _____ GALLONS

METHOD OF DECONTAMINATION PRIOR TO DRILLING: _____

DEVELOPMENT METHOD OF DEVELOPMENT: _____

DEVELOPMENT BEGAN DATE: _____ TIME: _____

YIELD:	GPM	TIME: FROM	TO	DATE:
YIELD:	GPM	TIME: FROM	TO	DATE:
YIELD:	GPM	TIME: FROM	TO	DATE:
YIELD:	GPM	TIME: FROM	TO	DATE:

TOTAL WATER REMOVED DURING DEVELOPMENT: _____ GALLONS

DESCRIPTION OF TURBIDITY AT END OF DEVELOPMENT: CLEAR SLIGHTLY CLOUDY MOD. TURBID VERY MUDDY

ODOR OF WATER: _____

WATER DISCHARGED TO: GROUND SURFACE TANK TRUCK STORM SEWERS STORAGE TANK DRUMS OTHER _____

DEPTH TO WATER AFTER DEVELOPMENT: _____ FEET

MATERIALS USED

_____ SACKS OF _____ SAND

_____ SACKS OF _____ CEMENT

_____ GALLONS OF GROUT USED

_____ SACKS OF POWDERED BENTONITE

_____ POUNDS OF BENTONITE PELLETS

_____ FEET OF _____ INCH PVC BLANK CASING

_____ FEET OF _____ INCH PVC SLOTTED SCREEN

_____ FEET OF _____ INCH STEEL CONDUCTOR CASING

_____ YARD³ CEMENT-SAND (REDI-MIX) ORDERED

_____ YARD³ CEMENT-SAND (REDI-MIX) USED

CONCRETE PUMPER USED? NO YES

NAME: _____

WELL COVER USED: LOCKING STEEL COVER CHRISTY BOX OTHER _____

SILT TRAP USED? NO YES

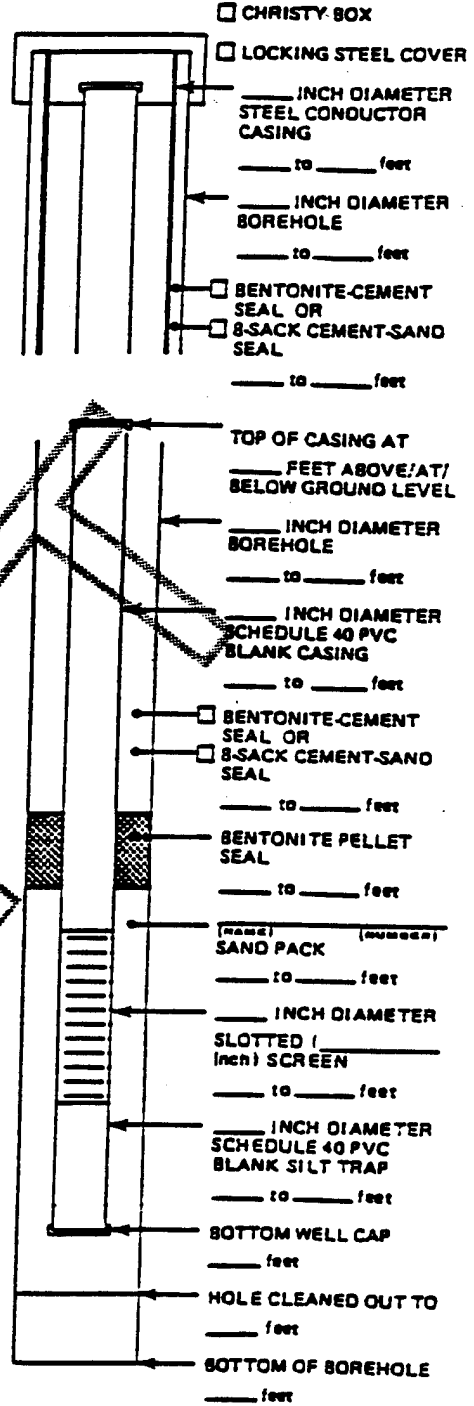

NOT TO SCALE

ADDITIONAL INFORMATION: _____

Prepared for:
 U.S. Army Program Manager's Office
 For Rocky Mountain Arsenal
 Aberdeen Proving Ground, Maryland

FIELD WELL COMPLETION FORM

MAJOR DIVISIONS					TYPICAL NAMES
COARSE-GRAINED SOILS MORE THAN HALF IS COARSER THAN NO. 200 SIEVE	GRAVELS MORE THAN HALF COARSE FRACTION IS LARGER THAN NO. 4 SIEVE SIZE	CLEAN GRAVELS WITH LITTLE OR NO FINES	GW		WELL GRADED GRAVELS WITH OR WITHOUT SAND, LITTLE OR NO FINES
			GP		POORLY GRADED GRAVELS WITH OR WITHOUT SAND, LITTLE OR NO FINES
		GRAVELS WITH OVER 12% FINES	GM		SILTY GRAVELS, SILTY GRAVELS WITH SAND
			GC		CLAYEY GRAVELS, CLAYEY GRAVELS WITH SAND
	SANDS MORE THAN HALF COARSE FRACTION IS SMALLER THAN NO. 4 SIEVE SIZE	CLEAN SANDS WITH LITTLE OR NO FINES	SW		WELL GRADED SANDS WITH OR WITHOUT GRAVEL, LITTLE OR NO FINES
			SP		POORLY GRADED SANDS WITH OR WITHOUT GRAVEL, LITTLE OR NO FINES
		SANDS WITH OVER 12% FINES	SM		SILTY SANDS WITH OR WITHOUT GRAVEL
			SC		CLAYEY SANDS WITH OR WITHOUT GRAVEL
FINE-GRAINED SOILS MORE THAN HALF IS FINER THAN NO. 200 SIEVE	SILTS AND CLAYS LIQUID LIMIT 50% OR LESS	ML		INORGANIC SILTS AND VERY FINE SANDS, ROCK FLOUR, SILTS WITH SANDS AND GRAVELS	
		CL		INORGANIC CLAYS OF LOW TO MEDIUM PLASTICITY, CLAYS WITH SANDS AND GRAVELS, LEAN CLAYS	
		OL		ORGANIC SILTS OR CLAYS OF LOW PLASTICITY	
	SILTS AND CLAYS LIQUID LIMIT GREATER THAN 50%	MH		INORGANIC SILTS, MICACEOUS OR DIATOMACEOUS, FINE SANDY OR SILTY SOILS, ELASTIC SILTS	
		CH		INORGANIC CLAYS OF HIGH PLASTICITY, FAT CLAYS	
		OH		ORGANIC SILTS OR CLAYS OF MEDIUM TO HIGH PLASTICITY	
HIGHLY ORGANIC SOILS		PT		PEAT AND OTHER HIGHLY ORGANIC SOILS	

UNIFIED SOIL CLASSIFICATION - ASTM D2487-85

Prepared for:
U.S. Army Program Manager's Office
For Rocky Mountain Arsenal
 Aberdeen Proving Ground, Maryland

**UNIFIED SOIL CLASSIFICATION
 SYSTEM**