



**REARM/RESUPPLY CONCEPT STUDY
FOR
THE LIGHT FORCES ARTILLERY**

DATE PUBLISHED - JUNE 1994

PREPARED BY

**CAMBER CORPORATION
200 VALLEY ROAD, SUITE 403
MT. ARLINGTON, NEW JERSEY 07856**

**FOR
DEPARTMENT OF THE ARMY
US ARMY RESEARCH, DEVELOPMENT AND ENGINEERING CENTER
PROJECT MANAGER - AMMUNITION LOGISTICS
PICATINNY ARSENAL, NEW JERSEY 07806-5000**

**CONTRACT #DAAA21-93-D-0013
DELIVERY ORDER #0002**



**DISTRIBUTION RESTRICTION: APPROVED FOR
PUBLIC RELEASE: DISTRIBUTION IS
UNLIMITED**

DTIC QUALITY INSPECTED 8

19950616 110



**REARM/RESUPPLY CONCEPT STUDY
FOR
THE LIGHT FORCES ARTILLERY**

DATE PUBLISHED - JUNE 1994

PREPARED BY

**CAMBER CORPORATION
200 VALLEY ROAD, SUITE 403
MT. ARLINGTON, NEW JERSEY 07856**

**FOR
DEPARTMENT OF THE ARMY
US ARMY RESEARCH, DEVELOPMENT AND ENGINEERING CENTER
PROJECT MANAGER - AMMUNITION LOGISTICS
PICATINNY ARSENAL, NEW JERSEY 07806-5000**

**CONTRACT #DAAA21-93-D-0013
DELIVERY ORDER #0002**

TABLE OF CONTENTS

1.0 INTRODUCTION

2.0 STUDY OBJECTIVE

3.0 BACKGROUND

4.0 PRESENT RESUPPLY OPERATIONS

4.1 RESUPPLY VEHICLES

4.1.1 ARMY PRIMARY DELIVERY METHOD - WHEEL VEHICLE

4.1.2 ARMY EMERGENCY DELIVERY METHOD - HELICOPTER

4.1.3 EMERGENCY DELIVERY METHOD - FIXED WING

4.2 DELIVERY AT BATTERY SITE

4.3 MARINE CORPS DELIVERY METHODS

4.3.1 AMPHIBIOUS ASSAULT DELIVERY METHOD

4.3.2 NON-AMPHIBIOUS ASSAULT DELIVERY METHOD

5.0 PRESENT REARM OPERATIONS

6.0 CONCEPT IDENTIFICATION

6.1 CHUTE CONCEPT (Man-Assisted Device)

6.1.1 DESCRIPTION OF CONCEPT

6.1.2 CHUTE STORAGE OPTIONS

6.1.3 CHUTE ATTACHMENT TO 5 TON TRUCK

6.1.4 REARM OPERATIONS

6.1.5 RESUPPLY OPERATIONS

6.1.6 MARCH ORDER

6.1.7 ASSUMPTIONS

6.1.8 ADVANTAGES

6.1.9 DISADVANTAGES

6.2 POWER CONVEYOR CONCEPT (Between Man-Assist Device & Automation)

6.2.1 DESCRIPTION OF CONCEPT

6.2.2 RESUPPLY OPERATIONS

6.2.3 LOADING CARGO ONTO PRIME MOVER

6.2.4 REARM OPERATIONS

6.2.5 UNLOADING CARGO FROM THE PRIME MOVER TO THE GUN

Accession For	
NTIS GRA&I	<input checked="" type="checkbox"/>
DTIC TAB	<input type="checkbox"/>
Unannounced	<input checked="" type="checkbox"/>
Justification	
By	
Distribution/	
Availability Codes	
Dist	Avail and/or Special
A-1	

- 6.2.6 ASSUMPTIONS
- 6.2.7 ADVANTAGES
- 6.2.8 DISADVANTAGES
- 6.3 CURRENT AND FUTURE TRUCK MATERIAL HANDLING EQUIPMENT (MHE)
 - 6.3.1 FIVE TON TRUCKS
 - 6.3.2 HEAVY EXPANDED MOBILITY TACTICAL TRUCK (HEMTT) AND LOGISTIC VEHICLE SUPPLY (LVS)
- 6.4 UNIT BASIC LOAD - UP-LOAD EQUIPMENT
 - 6.4.1 EXISTING UNIT BASIC LOAD-UPLOAD EQUIPMENT (UBL-UE)
 - 6.4.2 STRADDLE PALLET STACKER
 - 6.4.3 COMMERCIAL STACKER
 - 6.4.4 ASSUMPTIONS
 - 6.4.5 ADVANTAGES (Existing & Commercial Stacker)
 - 6.4.6 DISADVANTAGES (Existing & Commercial Stacker)
- 6.5 UNIT ROUGH TERRAIN LIFT TRUCKS
 - 6.5.1 DESCRIPTION OF CONCEPT
 - 6.5.2 LIFTING BULK PALLETS
 - 6.5.3 LIFTING PARTIALLY BROKEN-DOWN PALLETS
 - 6.5.4 BOOM LIFT ATTACHMENT
 - 6.5.5 EMPLACEMENT OF M198 & ATCAS
 - 6.5.6 ASSUMPTIONS
 - 6.5.7 ADVANTAGES
 - 6.5.8 DISADVANTAGES
- 6.6 MODULAR PROPELLING CHARGE STORAGE RACK
 - 6.6.1 DESCRIPTION OF THE CONCEPT
 - 6.6.2 DIMENSIONS OF MODULAR STORAGE RACK
 - 6.6.3 ASSUMPTIONS
 - 6.6.4 ADVANTAGES
 - 6.6.5 DISADVANTAGES
- 6.7 ISRAELI ARTILLERY TRAILER MODIFICATION TO 5 TON TRUCK
 - 6.7.1 DESCRIPTION OF CONCEPT
 - 6.7.2 OPERATIONS
 - 6.7.3 RESUPPLY OPERATIONS AT THE LRP
 - 6.7.4 ASSUMPTIONS
 - 6.7.5 ADVANTAGES
 - 6.7.6 DISADVANTAGES

6.8 POWER TAILGATE

- 6.8.1 DESCRIPTION OF THE CONCEPT**
- 6.8.2 ASSUMPTIONS**
- 6.8.3 ADVANTAGES**
- 6.8.4 DISADVANTAGES**

6.9 M198 LOAD TRAY

- 6.9.1 DESCRIPTION OF THE CONCEPT**
- 6.9.2 REARMING OPERATIONS**
- 6.9.3 ASSUMPTIONS**
- 6.9.4 ADVANTAGES**
- 6.9.5 DISADVANTAGES**

6.10 ARM II TECHNOLOGY (AUTOMATED SYSTEMS)

- 6.10.1 DESCRIPTION OF THE CONCEPT**
- 6.10.2 RESUPPLY OPERATIONS**
- 6.10.3 REARM OPERATIONS**
- 6.10.4 ASSUMPTIONS**
- 6.10.5 ADVANTAGES**
- 6.10.6 DISADVANTAGES**

7.0 COMPARISON OF CONCEPTS

- 7.1 RESUPPLY AT ATP/ASP**
- 7.2 RESUPPLY AT LRP**
- 7.3 RESUPPLY AT FIRING SECTION**
- 7.4 REARMING THE HOWITZER**

8.0 RECOMMENDED CONCEPT

- 8.1 RECOMMENDED CONCEPT FOR RESUPPLY AT ATP/ASP**
- 8.2 RECOMMENDED CONCEPT FOR RESUPPLY AT LRP**
- 8.3 RECOMMENDED CONCEPT FOR RESUPPLY AT THE FIRING SECTION**
- 8.4 RECOMMENDED CONCEPT FOR REARM AT THE FIRING SECTION**
- 8.5 RECOMMENDED CONCEPT FOR OVERALL RESUPPLY OPERATIONS**
- 8.6 RECOMMENDED CONCEPT FOR OVERALL REARM OPERATIONS**

9.0 CONCLUSIONS

ANNEXES

A. LIST OF FIGURES

B. ACRONYMS

1.0 INTRODUCTION

The rearm/resupply concept study for the towed 155mm howitzer was prepared by the Camber Corporation's Mount Arlington, New Jersey office for the Project Manager-Ammunition Logistics (PM-AMMOLOG) IAW SOW Paragraph 3.6. A four month study which examined the requirements of the 155mm towed howitzer rearm/resupply process from the Ammunition Transfer Point (ATP) to the howitzer's fighting position was conducted. The study included a review of the current logistic system for Class V ammunition, discussions and meetings with field artillery officers and noncommissioned officers with towed 155mm howitzer experience, commercial vendors, and a review of similar foreign towed artillery systems.

2.0 STUDY OBJECTIVE

The objective of this study was to develop rearm/resupply concepts in enough detail that hardware and software concepts could later be developed. The study looked at both the US Army and US Marine Corps current M198 system and their joint program, the Advanced Towed Cannon System (ATCAS).

The initial phase of the study was to determine how the users conduct present day resupply and rearming operations. This study phase consisted of data collection to examine: (1) current and future logistics chains, (2) existing and future rearm and resupply vehicles, (3) foreign medium towed howitzers and their rearm and resupply vehicles, (4) towed 155mm howitzer operations for both the Army and the Marines, and (5) the handling, storage, transportation and tactical deployment of conventional 155mm ammunition.

The second phase was concept development which ranged from complex automated systems to man-assist devices to simple mechanical aids. Concept(s) developed had to be capable of being transported on the M198's current and future prime mover. A reduction of 2-3 crew members of the firing section was addressed for each concept considered.

3.0 BACKGROUND

Resupply and rearm operations for US Army and US Marine Corps 155mm towed howitzer batteries are labor intensive processes. The majority of tasks in performing these operations are manual, stressful and very time consuming. In the Army resupply of the firing battery is performed by the Service Battery. The Marine Corps Combat Service Support (CSS) units are used to resupply their firing batteries. These CSS units use the Logistic Vehicle Supply (LVS), an 8x8 truck with MHE to conduct their resupply missions. Unlike the self-propelled howitzer batteries, towed artillery batteries have no dedicated rearm/resupply vehicle. Some 155mm towed howitzer batteries in the active and reserve

components use Heavy Expanded Mobility Tactical Truck (HEMTT) in their resupply operations. The HEMTT has material handling equipment (MHE), a lifting crane. In other towed 155mm howitzer batteries which have no HEMTT, resupply vehicles are 5 ton trucks. These 5 ton trucks have no MHE to lift ammunition.

A 5 ton truck serves as prime mover for the M198, towed 155mm howitzer. The entire 10 man firing section organizational equipment, 155mm and small arms ammunition is loaded in the cargo section of the prime mover. In addition to the equipment and ammunition, 7 crew members ride in back of the truck.

4.0 PRESENT RESUPPLY OPERATIONS

This section discusses how current resupply operations are conducted by the Army and the Marine Corps. Variations of resupply operations within the Army and the Marine Corps are based on the assigned equipment and their specific missions.

4.1 Resupply Vehicles

The Army and the Marines both use the 5 ton truck and the larger HEMTT and LVS for their resupply missions. The 5 ton trucks have no material handling equipment. Both the HEMTT and LVS have a crane which is used during resupply operations. Aviation assets from Corps and the Air Force are used for emergency resupply.

4.1.1 Army Primary Delivery Method - Wheeled Vehicle

The ammunition section from the Service Battery uses organic 5 ton trucks to draw Class V at the designated ATP. During training, the ammunition section travels to the ATP from twice a day to once every two days. During wartime, resupply trips to the ATP are conducted as needed.

Corps M871 trailers loaded with Class V high tonnage items are spotted at ATP sites in the Brigade Support Area (BSA) and Division Support Areas (DSA). Transloading ammunition from the Corps transportation vehicles to the resupply vehicle is accomplished by using forklifts at the ATP, cranes on the Service Battery HEMTT or manually breaking pallets down by hand.

After loading ammunition and departing the ATP, the Service Battery's next destination depends on the supply on-hand levels at the firing batteries. If resupply to the firing batteries is not urgent, then the Service Battery will travel to the battalion field trains locations. Ammunition is held there until needed by organic or attached batteries. Service Battery sets up a battalion Logistics Resupply Point (LRP) to issue Class III & V supplies to the firing batteries. When

the firing battery moves to a new location, the unit will stop at the LRP. When the firing batteries are low on ammunition, the Service Battery will deliver directly to the battery location.

4.1.2 Army Emergency Delivery Method - Helicopter

Emergency resupply requests are passed up command channels through Division to the Corps ending at the Corps Support Command (COSCOM) Materiel Management Center (MMC) where determination is made on the most expedient method to provide the emergency support. In many cases, it might be faster to divert a convoy which is already in-bound to the requestors Division. In the event that the main supply route (MSR) is obstructed, then an aerial resupply mission may be granted.

Delivery is conducted by Corps medium lift CH-47 or UH-60 Blackhawk helicopter from the Corps Support Area (CSA) airhead. Delivery location is normally forward of the ATP. A convenient location would be in the vicinity of the battalion trains, free of the debris of the support area. Depending on the drop site, availability of MHE may be questionable, if using the current 5 ton truck. The ammunition is delivered in A22 bags. The ammunition section must manually break down approximately 93 rounds stored in the bags which are at ground level. The rounds must then be lifted from the ground onto the bed of the resupply vehicle. After loading, ammunition sections travel to battery location to resupply the firing sections.

4.1.3 Emergency Delivery Method - Fixed Wing

In the event that emergency resupply requests cannot be performed by diverting convoys or by Corps helicopter assets, delivery may be conducted by C130 or C141 aircraft. This is the least frequent of delivery methods. However, it may be performed in undeveloped contingency theaters where the logistics chain is not matured.

Fixed wing aircraft conduct low velocity air drops (LVAD) at remote locations forward of the ATP. Sufficient ground clearance is required for aircraft to fly a low level profile run to drop Class V supplies. A suitable drop location may be distant from the battalion trains and battery site. An 8 foot 463L pallet is dropped from the aircraft which the ammunition section must manually break down. Availability of MHE is questionable when using the current 5 ton trucks. Therefore the rounds which are at ground level must be manually lifted onto the bed of the resupply vehicle.

4.2 Delivery at Battery Site

At the firing section the resupply vehicle parks in the vicinity of the M198 prime mover. Depending on the type of resupply vehicle being used ammunition may be in bulk pallets or already broken down. If HEMTTs are used, the crane will lift pallets either to the ground or to the back of the prime mover. For units having 5 ton resupply vehicles, no MHE is available. Class V supplies must be manually transloaded onto the prime mover. After the prime mover has been resupplied, crew members load the resupply truck with empty propellant charge containers and dunnage. Cross leveling of 155mm projectiles within the battery's firing sections is directed by the Fire Direction Center and crew members hand carry rounds from one gun section to another. This is a low level resupply action (1-3 rounds).

4.3 Marine Corps Delivery Methods

4.3.1 Amphibious Assault Delivery Method

Class V logistics support for amphibious assault operations is provided by supply ships off shore. Class V can also be drawn from prepositioned ships located around the world, which carry around 45 days supply of 155mm ammunition. During the assault, prime movers loaded with Class V, drive off amphibious landing vessels towing the M198s. Once established in their fighting positions, resupply is initially conducted by Marine medium lift helicopters. As the theater of operation matures, Ammunition Supply Points (ASPs) are established inland. At this point of the mission the primary delivery method is by 5 ton wheeled vehicles and later by LVS.

4.3.2 Non-Amphibious Assault Delivery Method

For non-amphibious assault operations, Marines set up ASPs instead of ATPs. Resupply missions to the ASP are conducted about once a day. In retrograde operations, Class V may be prepositioned to the rear of the battery position.

The battery is resupplied by point distribution which involves traveling to the ASP, drawing Class V, and returning to the battery location to transload supplies onto the prime mover. Another method of resupply is when the battery is on the move, and travels through a supply point off a main supply route to draw all classes of supply. This operation is usually conducted at night. Each Marine firing battery has two forklifts. However use by the battery ammunition section may be limited, since it competes with other classes of supply. If/when unavailable, 155mm pallets are manually broken down by hand.

They do not have assigned/dedicated trucks for their resupply missions. Battery trucks are made available when their battery commander commits their use in resupply operations. Up to 6 trucks are permitted for this mission.

5.0 PRESENT REARM OPERATIONS

Ammunition that is off-loaded must be protected from moisture and direct sunlight. For ammunition protection battery firing sections construct ammo hutch's composed of wooden ammunition pallets.

A review of load plans for the M198's prime mover, revealed that all components of the 155mm prepared round are located at the rear of the cargo bed. Both projectiles and propellant are stored loose in the truck. Projectiles are stored on base in a vertical position, secured with tie-down straps. No dedicated storage racks for 155mm ammunition are used. Some units assemble the Loose Projectile Restraint System (LPRS) to serve as temporary storage fixture on the back of the prime mover.

Propellant charge containers are located at the opposite side of the truck from the projectiles. Propellant containers are stacked in a horizontal position and are tied down against the side railings of the truck. Fuzes and primers are stored in their shipping boxes and are located next to the projectiles and propellant charges.

The ammo team chief is the focal point in the rearming operation. He directs when the rounds are hand carried off the back of the truck. Projectiles are stacked vertically on an ammo hutch, which is located next to one of the M198's split trails. The propellant charge containers are either kept on the prime mover or are stored in the same manner as the projectiles. Depending on the tactical situation, four to ten projectiles and propellant charge containers are manually off loaded from the rear of the prime mover. Both projectiles and propellant charges are stored separately on the constructed ammo hutches.

Projectiles are fuzed on the ground using a fuze wrench. Primers taken off the truck are either suspended from the lifting hook on the M198 or worn by the number one cannoneer. In an emergency situation, projectiles are fuzed on the prime mover. Both fuzed projectile and the called propellant charge are taken directly from the prime mover and then carried directly into the breach to arm the M198.

Before the fuzed projectile enters the breach it is lifted by one crew member, carried about 10 feet, and placed on the loading tray. Two crew members lift the loading tray and walk about 6 - 8 feet to the breach.

The round is rammed by two crew members using a ramming staff. After ramming, the propellant charge is placed behind the projectile, breech closed and primer inserted. After safety checks, the gun is ready for firing. Only one crew member is inside the split trails during firing.

After the round is fired, the sequence repeats until fire mission terminates. Remaining rounds on the ammo hutch must be uploaded onto the prime mover before the firing section can depart.

6.0 CONCEPT IDENTIFICATION

Ten concepts have been identified for investigation. Concepts presenting a low degree of complexity are the chute (Section 6.1), Unit Basic Load - Upload Equipment (Section 6.4), Modular Propelling Charge Storage Rack (Section 6.6), and M198 Mounted Load Tray (Section 6.9). Mid-Level complexity concepts using man assisted devices are Unit Rough Terrain Lift Trucks (Section 6.5), Israeli Artillery Trailer Modification to 5 Ton Trucks (Section 6.7), and Power Tailgate (Section 6.8). Near and fully automated systems are the Power Conveyor (Section 6.2), and a derivation of ARM II technology configured to a 5 Ton Truck (Section 6.10). Each of these concepts will be illustrated in detail in the following sections. A concept summary matrix listing each concept approach concerning its impact on rearm/ resupply operations is included in Section 7, Tables 1-4.

6.1 Chute Concept (Man-Assisted Device)

The first concept represents a simple man-assisted device which serves as an unpowered manual material handling aid. A plan view of the chute concept is shown in Figures 1 - 2.

6.1.1 Description of Concept

The Chute consists of rollers mounted in a frame of rugged galvanized steel. Rollers are two inches wide x 12 gauge unplated steel with sealed grease packed bearings. There are three special break rollers that slow the decent of the projectile. These rollers are evenly positioned along the twelve foot length of the chute. A portable tripod stationary support located at the end of the chute provides stability and weight distribution.

The following dimensions are for chute use on current 5 ton trucks used as resupply vehicles and as the M198 prime mover. Chute width must be greater than 8.75 inches, the width of the widest section of the propellant charge container. The 155mm projectile width is about 6.1 inches. Therefore a chute

design of 9 inches in width would allow adequate space for both the projectile and the propellant charge to travel freely down the chute. This width can be reduced to around 6.5 inches, if the user preferred to use the chute to only transfer projectiles.

6.1.2 Chute Storage Options

Three possible options are presented as locations for chute storage. The first option is to stow directly under the center cargo bed liner of the current 5 ton truck series. Modification to the truck would be to remove a 10 inch wide by 5 inch long metal panel. This section is located directly above the towing pintle. Once removed, the exposed opening would allow the chute to be rolled out and rolled back under the truck bed.

The second option is to stow on the Future 5 Ton Class Trucks from the Family of Medium Tactical Vehicles (FMTV). The chute may be stored in the ladder storage section. Relocate the ladder to driver side storage compartment. A modification to rear downside panel section is required to allow chute to pass through. A 9.5 inch wide by 3 inch high section would be removed.

Third option is to mount chute directly above the right trail leg of the M198. The trail leg is about 12 inches wide and with modifications the chute can be mounted on the leg. Modifications might be welding a metal plate or bracket on the trail leg to serve as a mounting platform for the chute.

6.1.3 Chute Attachment to 5 Ton Truck

Two approaches are offered to attach chute to the 5 ton truck. The first approach is to place a bolt through the bed liner of the truck. This bolt would be inserted into the top end of the chute and through bed of truck. Bolt would allow chute to pivot to the right and left. Drilling a hole into the cargo bed liner is required using this approach. The other approach is to have the top end of the chute have a curved hook attachment which hangs over the lowered metal tailgate. No modification to the truck is required for this approach.

6.1.4 Rearm Operations

After the chute has been installed to the prime mover and support legs located at the end of the chute are emplaced, rearming operations are ready to begin. One crew member is positioned on cargo section of the prime mover. He takes the selected projectile and places it onto the chute. Two crew members are at the opposite end of the chute holding the loading tray next to the chute, about waist high. The projectile is rolled on to the loading tray. The crew members carry the loading tray and walk about 7 - 18 feet to the howitzer. At the breech opening, two additional crew members use a ramming staff to ram the round. An area of

about 8 feet directly in front of the breech is required for ramming. After ramming, one of the crew members carries the loading tray back to the chute. The propellant charge is hand carried to the breech and placed into the tube. Optionally, the propellant charge containers can be carried down the chute. Empty containers need to be brought back to the prime mover. After the charge is cut, unused portions of the charge must be walked behind the prime mover and raised for verification of the called charge before firing. The breech is then closed and primer is inserted. After safety checks have been observed, lanyard is pulled, firing the round. Figure 1 shows two views of the chute used in the rearm process.

6.1.5 Resupply Operations

Resupply operations for this concept are based on the assumption that the battery's ammunition section has broken down either bulk 155mm projectile pallets and/or combat configured load pallets. The chute to be used for the transfer of loose 155mm projectiles belongs to the resupply truck.

The diameter of the chute must be wide enough to permit the propellant charge containers (8.75" diameter) to pass through the chute. Built into the base of the chute are rollers that allow ease of movement when the chute is configured in a horizontal position during resupply operations. At least two crew members, one from the ammunition section and the other from the firing section are required for this operation. To transload projectiles and propellant charge containers, the resupply vehicle must park within 12 feet of the prime mover. Parking parallel to the prime mover would be the preferred parking arrangement. The resupply process using the chute is shown in Figure 2.

The side wooden railing section, closest to truck's rear between the two metal bow supports, must be modified to allow this section to slide or fold down to permit the end of the chute to rest on the metal side railings of the truck. Prime mover would require the same modifications to accept the opposite end of chute passing over its wooden railing section. Support legs located at the end of chute are lowered inside the bed of the prime mover. Camouflage netting must be lifted to allow the opposite end of the chute to rest on top of the metal railing.

6.1.6 March Order

After the fire mission is completed and march order has been issued, projectiles and propellant charges on the chute must be either removed and hand carried back to the bed of the prime mover, or pushed up the chute to the bed.

The chute's support legs are either removed and placed under cargo bed or on back of the prime mover. Chute can be rolled in under the cargo bed or

detached from the cargo bed, stored in the FMTV side structure section or mounted on the trail leg of the M198.

6.1.7 Assumptions

1. If chute can be inserted inside the split trails, then extend chute to about 7 feet away from the breech opening.
2. Chute will be able to attached to the truck bed and to either side of the truck's metal side walls.

6.1.8 Advantages

Simple to operate. Degree of maintenance to repair chute is at the organizational level. No tools are envisioned to be used with this concept. Since the concept is gravity dependent, no auxiliary power units or hydraulics systems are needed.

Constructed of durable galvanized metal, the chute's reliability, availability and maintainability factors could be established at a very high level. Due to simple design, it should be a low technical risk to develop. The only item added to the battery inventory is the chute. In the event that the prime mover or the resupply truck becomes nonoperational, the chute can be quickly transferred to another 5 ton truck in the battery, if vehicles have been modified to accept it.

6.1.9 Disadvantages

Two crew members still must use loading tray and walk 7-18 feet to the breech. Projectiles and propellant charges not fired must be hand carried back to the prime mover, or pushed up the chute. Storage space must be allocated under the cargo bed for the chute and support legs. Both resupply truck and prime mover require modification.

6.2 Power Conveyor Concept (Between Man-Assist Device and Automation)

This concept utilizes materiel hardware taken from the M992, Field Artillery Ammunition Support Vehicle (FAASV) which is used in the self-propelled artillery. This idea originated from the combat user, TSM-Cannon. The hardware to be incorporated from the M992, illustrated at Figure 3, are the conveyor, telescoping rods with conveyor supports, auxiliary power unit (APU) and generator, hydraulic system (pump, actuators, control panel, reservoir components and lines), cables and projectile storage racks. Additional hardware to be designed are a heavy duty metal bow and its mounting brackets, stabilization plates and a metal shelter.

6.2.1 Description of Concept

The conveyor is mounted in a 5 ton truck at the rear of the cargo bed on the driver's side. Modifications are made to the pedestal which supports the conveyor. The pedestal is mounted at the rear section of the cargo bed liner on the driver side. The height of the pedestal needs to be extended about 2-3 inches to allow the conveyor to clear the metal side walls of the truck. A pivot attachment to the pedestal is needed to allow the conveyor to rotate in a left and right direction. Behind the pedestal are three projectile storage rack assemblies. Each rack consists of nine tubes, storing up to 27 projectiles. Liquid filled projectiles and Copperhead rounds cannot be stored in these racks.

The APU and Hydraulic System are located on the driver's side of the cargo bed, mounted in a metal shelter. This metal shelter is a new item to be designed. The outside surfaces of the shelter are the control panels for the APU and hydraulic System. The opposite side faces out over the side metal or truck railing. It's surface contains the intake and exhaust ducts for the APU. The inside of the shelter houses the APU engine, generator, hydraulic priming pumps and reservoir components. Hydraulic lines travel under cargo bed and appear through the cargo bed up along the pedestal, connected to the conveyor.

The hydraulic control panel requires modification. This concept does not utilize the M992's ammunition loader (stacker) and has no ballistic shields so the panel can be downsized. Hydraulics are only needed to operate the conveyor motor. The hydraulic actuators' main functions are opening and closing the upper rear door of the M992. The role the hydraulic actuators would perform in this concept is operating the conveyor motor. Rotational direction of the motor and its speed are determined by the conveyor directional control valve and the flow control valve. These two valves are part of the hydraulic actuators. Redesigning this actuator offers possible size reduction benefits.

Two cable lines are connected to a swivel attachment from the truck's bow to the conveyor. This bow is located at the end of the cargo bed, closest to the truck's tailgate. In order to support the weight of the conveyor when it is deployed from the truck, it should be constructed of high strength material. The existing wooden bow would be replaced with a metal bow that is inserted into reinforced support brackets. The bow would also require stronger brackets for support in the sides of the cargo bed.

Conveyor support poles are located in telescoping rods. At the end of the each pole are end sockets which line up with the balls of the conveyor take up section. This end is secured by closing hand clamps. The opposite end of the telescoping rods is rotated towards the ground. This section would require modification to install a stabilization plate.

The stabilization plate is a new item to be designed. The use of the telescoping rods with the conveyor support poles is not as in the M992. In this concept, the telescoping rods and conveyor support poles serve as ground emplacement legs. There may be a possible reduction in length of the conveyor support and telescoping rods, since the distance from the conveyor to the ground is shorter than the distance from the conveyor up to the top interior ceiling of the M992.

6.2.2 Resupply Operations

The pedestal needs to have the ability to rotate 90 degrees to the left and right sides of the truck. The increased pedestal height is to allow the conveyor to operate over the sides of the current 5 ton truck series. The pedestal height would not have to be increased if using the FMTV 5 ton with its drop down sides.

Before the conveyor is deployed, it is rotated in the direction of the resupply truck. The resupply truck can be parked either parallel or perpendicular to the prime mover. The distance between each truck cannot exceed 15 feet, the length of the conveyor. The ends of the two support cables are connected to a swivel, allowing rotation of the cable in the direction that the conveyor is to be unfolded. A stowage strap that is wrapped around the metal bow is removed, allowing the conveyor to be deployed. Additional stowage straps may be required to secure conveyor when traveling on the road, especially during cross country movement.

To activate, the soldier pulls conveyor-deploying handles toward rear until the conveyor is fully extended. The conveyor center hinge is stabilized by pulling forward on the red handles. Once extended and stabilized, telescoping rods and conveyor supports are then connected to the conveyor. Stabilization plates are placed on the ground between the conveyor and telescoping rods and conveyor supports are attached to the plates.

6.2.3 Loading Cargo Onto Prime Mover

Operating the conveyor follows the same procedures and warnings as in the M992, except for the conveyor deployment. The steps are:

1. Deploy conveyor in accordance with this concept's procedures.
2. Position resupply vehicle either parallel or perpendicular to the prime mover and within 15 feet of each vehicle; or back up prime mover to an ammunition stockpile.
3. Attach ground cable to truck or stockpile.
4. Activate hydraulic system. Position conveyor switch to IN.

5. Place ammunition onto outboard end section of the conveyor. Projectiles should be placed onto conveyor base-first.
6. Push ammunition onto conveyor chain. Conveyor will move ammunition to inboard end section.
7. When ammunition reaches inboard end section, it must be removed promptly and stowed in projectile racks. Special 155mm projectiles and liquid filled projectiles are stored in other designated areas.

6.2.4 Rearm Operations

Deployment of the conveyor is essentially the same as in the resupply operations. The only minor difference is that the pedestal and the two cables do not require left or right rotation.

In rearming operations, the conveyor is not facing directly into the middle of the howitzer's split trails. The conveyor is positioned off center either to the right or to the left. The prime mover does not enter the "V" of the split trails. Projectiles and charges traveling to the end of the conveyor slide onto the loader tray and are hand carried approximately 7-18 feet to the breech opening. Figure 4 is an illustration of the power conveyor.

In the event the Fire Direction Center orders it's firing sections to shift their firing fans, the conveyor belt must be stopped. The conveyor is folded up back towards the prime mover. Then the split trail legs of the howitzer are lifted up by the crew members of the firing section and shifted either to the right or left. Once firing section has adjusted

their firing fan, the prime mover is moved forward and ground guided directly back into the split trails of the howitzer. The conveyor is extended to the rear, resuming rearm operations.

6.2.5 Unloading Cargo From The Prime Mover To The Gun

Follow the similar procedures and warnings as in the M992. The main difference is that in this concept cargo unloaded is intended for rearming the howitzer. In the M992, unloading using the conveyor is to load the self-propelled howitzers for storage.

The steps for rearming the howitzer using this concept are:

1. Deploy conveyor in accordance with concept procedures.

2. Maneuver prime mover and conveyor, as necessary, to position outboard end section to comfortable unloading location within 7-18 feet from the breech opening.
3. Attach grounding cable to truck or howitzer.
4. Activate hydraulic system. Move conveyor switch to OUT.
5. Remove a projectile from rack and slide projectile over inboard end section onto conveyor chain.
6. Place proper propelling charge (called for by howitzer crew) onto conveyor chain behind projectile.
7. Howitzer personnel will remove projectile from the outboard end section of the conveyor and place projectile into the loading tray, two crew members carry the projectile to the breech. After projectile is rammed, charge is picked up and inserted into the breech.
8. Repeat steps 5, 6 and 7 to rearm howitzer, as required.

6.2.6 Assumptions

1. The APU and hydraulic system can be safely integrated onto the current 5 ton truck series and the new family of medium tactical vehicles.
2. The warnings and caution statements found in the M992 operator's manual will apply to this concept.
3. This concept will not rule out the use of manual labor by the crew.
4. Set up time to put the conveyor into and out of operations will be faster than the system used in the M992.
5. That the ammunition loader (stacker) would take up too much space in the cargo bed. Only one set of projectile racks stacked 3 high are used in this concept. Therefore the stacker is not needed since only 27 projectiles are stored compared to 95 projectiles stored in the M992.

6.2.7 Advantages

1. Minimal lifting is required.
2. Resupplying the prime mover is conducted in an expedient manner.

3. Use of proven hardware from the M992.
4. Minor modifications of hardware is needed for concept to work.
5. Only new items introduced are the heavy duty metal bow, its support bracket, stabilization plates, and metal shelter.
6. Low technical risk to develop concept.

6.2.8 Disadvantages

1. Firing section is faced with more safety hazards.
2. Additional weight and storage space is consumed by the hardware components.
3. Equipment may break down more frequently than the same equipment used in the M992, since it is also used in the rearm process.
4. Possible additional MOS may be added to the battery to maintain this concept.
5. This concept may not result in the ATCAS requirement for a reduction of 2 - 3 of crew members.

6.3 Current and Future Truck Material Handling Equipment (MHE)

This section outlines truck material handling equipment currently available for the movement of Class V field artillery supplies, and the impact on resupply operations of future Army and Marine Corps vehicles with MHE.

6.3.1 Five Ton Trucks

The current 900 and 800 series 5 ton truck used by towed 155mm field artillery batteries have no crane to lift the pallets of ammunition. The Army uses the M925A1, M923 and M813 for their prime movers and resupply trucks. The M923 and M818 5 ton trucks are used by the Marine Corps .

The Army's aging 800 and 900 series 5 ton trucks will be replaced from The Family Of Medium Tactical Vehicles (FMTV). Two models (M1084 and M1086) are equipped with a crane as shown in Figure 5. These cranes are hydraulically operated, with a line capacity of 2,500 pounds lift at 14 feet. The crane is similar in size and feature to the crane found on HEMTT. FMTV model M1083 has a standard cargo bed with no MHE and the M1086 has a long cargo bed with MHE. Both vehicles were field tested at Fort Bragg during the fall of 1993 by

Alpha battery, 1/39th FA Regiment (Airborne) with their M198s. Initial comments concerning the M1086 were that the firing section was unable to draw equipment and ammunition from the rear tailgate section of the truck because the crane was mounted behind the tailgate. For this reason the crew preferred the M1083 standard cargo bed without MHE for their prime mover. TEXCOM will continue testing for the towed artillery in the June 1994 timeframe. Fielding of the FMTVs to the 1/39th FA Regiment (Airborne) is scheduled for the spring of 1995. Since production, over 40 modification work orders have been introduced.

Being an airborne unit, 1/39th will probably receive the M1093, a standard cargo low altitude parachute extraction system (LAPES)/air drop (AD) FMTV variant for the prime mover. Figure 6 illustrates the two possible FMTV prime mover candidates. These models have no MHE and may be their prime mover. The model for the Service Battery will be either the M1084 or the M1086. The M1086 can hold up to 200 projectiles during wartime, 100 projectiles during peacetime.

The Marine Corps has no plans to procure the 5 ton class FMTVs. They plan an upgrade program for their M923 to increase the cargo carrying capacity from 5 ton to 8 ton. This involves strengthening the trucks power train and suspension systems.

6.3.2 Heavy Expanded Mobility Tactical Truck (HEMTT) and Logistic Vehicle Supply (LVS)

The next level of tactical trucks (8 X 8) are the Heavy Expanded Mobility Tactical Truck (HEMTT) for the Army and the LVS MK48 series articulated vehicles for the Marine Corps. These vehicles are currently in use and have models with cranes.

Service Battery, 1/39th FA Regiment (Airborne) has 18 HEMTT which they received during Desert Storm. Prior to Desert Storm, their main resupply vehicle was the M813 5 ton truck with no MHE. The HEMTT is not on the battery Modified Table of Organization and Equipment (MTOE) and is serving as an interim resupply vehicle until the 5 ton FMTV with MHE is fielded. HEMTTs can carry around 200 projectiles (25 pallets) and tow a trailer with other smaller components of the 155mm round. Two cargo truck models, the M977 and M985, are used.

When resupplying firing sections in position, HEMTTs travel to gun positions and unload pallets of 155mm projectiles and powder canisters using the crane and by manually unloading by the crew. Loose projectiles, fuzes and primers are hand carried off the HEMTT. Using the crane, and the Multiple Leg Sling up to three pallets of 155mm projectiles can be offloaded at a time. The 1/39th

Battery personnel were unaware of the existence of the Multiple Leg Sling. The Multiple Leg Sling is illustrated in Figure 7.

Logistics Area Resupply Point (LRP) operations are conducted by the Service Battery. Ammunition is off loaded to the ground by either MHE or manual labor. Having the ability to lift more than one pallet at a time with the Multiple Leg Sling would expedite transfer operations. This would allow the HEMTTs to return sooner to the ATP. Usually each platoon drives through a LRP to pick up its ammo. For each platoon there are 4 ammo stockpiles, one for each gun. Loading these stockpiles on the prime mover is manually conducted by the firing section members.

The Marine resupply vehicles are the MK48 series, known as the Logistic Vehicle System (LVS). These vehicles are made by Oshkosh and look just like the Army's HEMTTs, having about 70% commonality with the HEMTT. The MK48/17 cargo truck has MHE and a cargo capacity of 22,000 pounds. During fiscal year 1996, three of MK48/17 will be fielded down to battalion level. Currently only their Combat Service Support (CSS) organizations have the LVS.

Resupply of ammo to the gun position is conducted from the CSS organizations. Ammo is pushed forward in bulk form to the battery. Off loading a pallet of 155mm projectiles is performed using the crane on the MK48/17. The sling used is a metal bar and chains. This attachment does not evenly distribute the weight of the pallet. Use of the Multiple Leg Sling would provide a safer and quicker method of off loading pallets to the ground. Each marine battery has 2 forklifts. Forklifts are used to lift ammo and to emplace the M198.

The MK48/18 variant has a Palletized Load System (PLS) capability. It uses a Reynolds Boughton load handling system mounted on the MK48 series trailer. This system when fielded will improve resupply operations at their ammunition supply points and to push greater quantities of Class V forward to their batteries.

6.4 Unit Basic Load-Upload Equipment (UBL-UE)

This section examines the potential of using existing unit basic load-upload equipment by a towed 155mm howitzer battalion. Commercial off-the-shelf equipment similar to the equipment found in the Army's inventory is listed as an option for consideration.

6.4.1 Existing Unit Basic Load -Upload Equipment (UBL-UE)

The unit basic load-upload equipment is used to assist artillery units in drawing their basic load of 155mm ammunition during mobilization. Figure 8 shows the six pieces of equipment that constitute the UBL-UE: Projectile Pallet Hand Truck;

Pallet Truck (Jack); Wagon Truck; Straddle Pallet Stacker; Aluminum Ramp (16ft); Jib Boom Assembly with optional electric winch; and a Pallet Mobilizer.

All of UBL-UE are mechanical aids that would benefit the Service Battery of a towed 155mm battalion at a stateside Army installation ammunition storage site. These stateside storage sites are permanent locations. The equipment used during peacetime to draw ammunition is owned and operated by the ammunition storage site. During mobilization all combat deploying units located at stateside installations will be drawing their basic loads at the ammunition storage site. Having the UBL-UE in addition to their current HEMTT and their future FMTV with MHE would expedite the Service Battery uploading the battalion's basic load.

Use of the UBL-UE is ideal in an stateside environment. However, this equipment is not configured to work well in the field, especially during inclement weather conditions. Five of the six pieces of UBL-UE have wheels that are not designed for movement of heavy cargo in rough terrain. Once in the field, the majority of the movement of 155mm projectiles is uploading and downloading from 5 ton and HEMTT trucks.

6.4.2 Straddle Pallet Stacker

Only the Straddle Pallet Stacker is configured for lifting ammunition to reach the bed of both the HEMTT and the 5 ton truck. This piece of equipment would assist each firing battery platoon when they drive through a LRP. The Straddle Pallet Stacker would be left next to the pallets of 155mm projectiles that were placed on the ground by the Service Battery. As they pass through the LRP each firing section would operate the Straddle Pallet Stacker to load their prime mover. The Straddle Pallet Stacker would remain at the LRP location until resupply operations are completed. The Service Battery would then retrieve the Straddle Pallet Stacker using the crane on the HEMTT or FMTV.

The Straddle Pallet Stacker would have to be modified in order to be used in the field. The tires would have to be larger with rough terrain type tread. Adding a 5th tire with a towing and steering handle will provide greater maneuverability and precise handling in tight spaces. This equipment would be stored and transported on Service Battery resupply vehicles. Since LRP operations are conducted at the platoon level, in a 3 X 8 towed 155mm howitzer battalion, at least four Straddle Pallet Stackers would be required.

6.4.3 Commercial Stackers

Commercial stackers are available similar to one already in the Army inventory. Two possible options for consideration are a manually propelled foot pump raise/lower non-straddle stacker and a manually propelled battery raise/lower

non-straddle stacker as shown in Figure 9. These stackers have a 1000 pound lifting capacity. The raised height depending on model selected, is 52, 66 and 78 inches. The distance from the ground to the bed of the M923A1 is 58.2 inches. FMTV standard cargo bed model M1083, has a distance of 62 inches from the ground to the top of the cargo bed.

The model that has a maximum raised height of 66 inches would be applicable for lifting 155mm pallets to the bed of the prime mover. Both stackers have a narrow base. Outside dimension is 21 inches and inside base dimension is 15 inches. The foot pump raised/lowered model has a height of 80 inches, width of 27 inches, length of 42 inches and weighs 320 pounds. Purchase price based on one order is \$1054.00. The battery raised/lowered model has a height of 80 inches, width of 27 inches, length of 49 inches and weighs 470 pounds. This model contains a heavy duty battery with built in charger and amp meter. These two models would also require modification to replace existing floor protective high impact plastic wheels with rough terrain inflatable tires. Adding a 5th tire with a towing and steering handle will provide greater maneuverability and precise handling in tight spaces.

6.4.4 Assumptions

1. Mobility modifications to the stacker can be performed.
2. Only minor changes to the Service Battery resupply vehicle load plan is needed to incorporate the stacker.
3. A pallet of interlocked propellant canisters, along with fuze boxes and small arms ammo boxes can be lifted with the stacker.

6.4.5 Advantages (Existing and Commercial Stacker)

1. By lifting projectile pallets up to truck bed level, resupplying the prime mover is faster than manually lifting projectiles and propellant canisters one at a time.
2. The stacker is not part of the prime mover's basic load. Ownership belongs to the Service Battery.
3. Simple to operate and to maintain.

6.4.6 Disadvantages (Existing and Commercial Stacker)

1. Additional piece of equipment for Service Battery resupply trucks.
2. Requires modification to install a 5th tire with a towing and steering handle.

3. Use of the crane from the HEMTT and/or FMTV is needed to lift stacker on and off the truck.

6.5 Unit Forklifts

This concept originated from visiting 1/39th FA Regiment (Airborne). The battalion commander discussed the idea of having a small truck forklift to assist his soldiers in the movement of projectiles. This concept is intended for the Army, since the Marine Corps towed 155mm battery has two organizational lift trucks.

6.5.1 Description of Concept

Two rough terrain lift trucks would be used by each firing battery, one for each platoon. Rough terrain lift trucks would pick up ammo that Service Battery off loaded at the gun site. When Service Battery delivers ammunition to the gun site it is offloaded on the ground. Since the current prime movers have no cranes, the ammunition is manually loaded onto the prime mover. Each firing platoon could use a rough terrain lift truck at the LRP site to lift ammo off the ground and up to the prime mover. The rough terrain lift truck can be driven onto a trailer towed by a 5 ton truck. This would require a metal ramp for forklift truck to drive up and down from the trailer, or the rough terrain lift truck could be towed. Commercial rough terrain lift trucks offer optional towing packages. See Figure 10 for an illustration of a commercial rough terrain lift truck. Four potential options are provided for using a rough terrain lift truck in a towed 155mm howitzer battery.

6.5.2 Lifting Bulk Pallets

Using the forklift truck, one pallet can be lifted at a time and carried over to the tailgate section of the current five ton trucks. For FMTV 5 ton trucks with fold down side railings, pallet loading is not limited to the rear of the truck. Delivery can be to any side railing that is folded down. When pallet loading is positioned on or next to cargo bed, metal packaging bands are cut, and top and bottom wooden pallet sections are removed. The loose projectiles are lifted one at a time into the LPRS.

6.5.3 Lifting Partially Broken Down Pallets

Another option using the rough terrain lift truck is to pick up only the 8 projectiles and the top wooden block of the pallet. Before a pallet of 155mm is lifted using the lift truck, the metal bands are cut. A custom sling with one end which can quickly attach to each of the 8 lifting plugs and the opposite end connected to the forks is required. An example of this sling is shown in Figure 11. In this option the 8 projectiles are lifted with the top portion of the shipping pallet. The

bottom pallet is not used. This load is lifted higher to clear the top of the Loose Projectile Restraint System (LPRS). Suspended projectiles are then lowered into empty sections of the LPRS. Using this options reduces the amount of manual lifting of projectiles. However, some lifting of projectiles already stored in the LPRS may be rearranged to allow the suspended projectiles to be lowered into the vacant sections of the LPRS.

6.5.4 Boom Lift Attachment

The third option is to use a commercial boom lift attachment, shown in Figure 12. This attachment instantly converts fork lift trucks to mobile jib cranes. Forks of the lift truck are inserted into the sleeves of the boom lift. Boom lift attachment has retaining chain and safety clevis safety hooks. Using the multiple leg swing, six loose projectiles can be lifted, suspended over the LPRS and lowered into vacant compartments. Eight projectiles can be lifted using the procedures listed in section 6.5.3. The boom length is from 81 inches when fully extended to 144.25 inches. When fully retracted (81 inches) the maxim load capacity is 4000 pounds; extended to 144.25 inches the load capacity is reduced to 1935 pounds. The height of the boom is only 20 inches. The boom weighs 365 pounds. Purchase price for one unit ordered is \$574.00. This commercial boom attachment far exceeds the lifting capacity required to hoist one pallet of projectiles. However a smaller size may be more suitable at platoon level.

6.5.5 Emplacement of M198 and ATCAS

The last option is to have a towing package added to the rough terrain lift truck. Using this feature, the towed howitzer can be emplaced faster in a location containing many obstructions compared to using the larger prime mover. The Marine Corps field artillery batteries use this technique to quickly emplace their M198s. Depending on the size of the rough terrain lift truck, it may be towed by another five ton truck.

6.5.6 Assumptions

1. The rough terrain lift truck has the power to emplace the M198.
2. A custom sling can be made that will safely lift partially loose projectiles.
3. Use of the rough terrain fork lift is not limited to the firing batteries. Service Battery may use it when their resupply vehicles cranes are nonoperational.
4. Rough terrain lift truck and boom attachment will fit inside 1.5 ton truck trailer.

6.5.7 Advantages

1. Manual lifting is significantly reduced using any of the first three operations.
2. Time spent uploading ammunition at the LRP is reduced. This enables the platoon to arrive sooner at their next battle position.
3. Use of the boom attachment with the forklift, provides a crane hoist capability at platoon level.
4. All options are readily available using commercial equipment.
5. Low technical risk to develop custom sling hoist.

6.5.8 Disadvantages

1. Rough terrain forklift truck must be shared between four firing sections in the platoon for moving ammo and to emplace the howitzers.
2. If trailers are used to transport the forklift trucks, then supplies originally stored in the trailer may have to be relocated.
3. Metal ramp is needed to load and unload rough terrain forklift truck from the trailer. Storage location for ramp must be allocated.

6.6 Modular Propelling Charge Storage Rack

This section addresses the storage of propellant charge canisters. Currently there is no dedicated storage system in the prime mover for the towed artillery. On the cargo bed, canisters are stacked horizontally on a wooden pallet. Before starting the next higher level, wood boards are placed between each level. Three to four tiers are constructed. Straps are used to tie down the newly constructed propellant charge pallet to the side railings of the prime mover.

6.6.1 Description of the Concept

Modular storage racks are composed of a single compartment that are stacked together to hold canisters horizontally. Each single compartment is free standing and easy to handle. The system can readily be rearranged to meet the firing section changing needs concerning the M3A1, M4A2, M119A2, and M203A1 standard series of propellant charges. No bolts, tools, or fittings are required in set-up or take down of this modular rack system. Each compartment has a built-in strap restraint system. This system works on the same principle used in seat belts in an automobile. The only exposed portion of the strap restraint system is the hook. The hook is pulled out and upward to pass over the

stack of propellant canisters attaching to the side railing. On the FMTV models, the hook will be attached to fittings that are recessed inside the bed of the truck. A minimum of two compartments, one at each end of the canister are required to store the M203A1 the longest of the three canisters. For application for the towed artillery, the rack compartment could be constructed with similar lightweight materials used to make the Loose Projectile Restraint System.

6.6.2 Dimensions of Modular Storage Rack

Each compartment stores nine M203A1 canisters. The diameter of M203A1 canister cap measured diagonally is 8.75 inches. In order to store nine canisters, the dimensions of each compartment is 45 inches length, 4 inches wide and 18 inches high. The inside length needs to be 44 inches and a inside post height of 17.5 inches. There are four posts that are used to stack compartment to built the next tier of canisters. See figure 13 for an illustration of the modular storage rack.

The first tier of the modular storage rack system is formed using two compartments as the base, containing nine canisters in each compartment. Two rows form the first tier, five canisters for the first row, 4 canister for the second row. To build the second tier, two additional compartments are placed onto the posts of the base compartments. Again nine canisters can be placed in each compartment. Due to the modular design, various configurations are possible for the section chief to construct the storage rack to save space on the prime mover. To prevent shifting, the rack is strapped down using the built-in strap restraint system.

6.6.3 Resupply Operations at the LRP

Using this concept would save time during the resupply operations at the LRP. The time to upload propellant canisters can be reduced by constructing on the ground a pallet of propellant charges using the modular rack system. Canisters are secured by using the built-in strap restraint system. To lift the pallet from ground level to the bed of the prime mover, the firing section can utilize their platoon's forklift or use Service Battery's straddle pallet stacker.

Construction of the propellant charge pallets could be conducted by Service Battery at the LRP location either on the ground or onboard their resupply vehicle.

6.6.4 Assumptions

1. Modular storage rack system can be manufactured using light and durable materials.

2. Using this system may free up floor space on the cargo bed of the prime mover.

6.6.5 Advantages

1. Rack system can be designed in different configurations to meet the specific storage requirements in the prime mover.
2. This system can be used to stack fuzes, small arms ammunition, primers and Copperhead containers.
3. Up loading a pallet of propellant charge canisters using this rack system may be faster than having to reconstruct a propellant canister pallet on the prime mover.

6.6.6 Disadvantages

1. Storage space is needed for compartments not utilized.
2. Modular rack system is an additional piece of equipment that would be added to the prime mover and resupply vehicles.
3. Depending on the amount of propellant canisters to be stored, this concept may not reduce storage space on the prime mover.
4. Modular rack system is not available in the commercial market and would need to be developed.

6.7 Israeli Artillery Trailer Modification To 5 Ton Truck

The two wheel vehicle, 155mm Field Artillery Ammunition Trailer (ARTRAIL), is a trailer designed by Israel to resupply self-propelled howitzers. Forty four, 155mm projectiles and propellant charges are stored inside the trailer compartments. The front compartment has two doors that open up exposing 36 projectiles. The rear compartment contains 44 propellant charges. Eight white phosphorus rounds are stored vertically in a side storage compartment. A conveyor assembly is located at the base of the projectile storage compartment. It has a gravity driven conveyor to move the projectile to the self-propelled howitzer.

ARTRAIL was evaluated in 1988 by the U.S. Army Combat Systems Test Activity to assess the safety and operational capabilities of this foreign built system. The examination covered the transportation of live ammunition, human factors, safety, vehicle interface, environmental operations, and automotive endurance.

The concept in this section uses only the ammunition compartment storage case. The deficiencies relating to the compartment storage case were : (1) no interlock to prevent a round from being released from the ammunition rack while a round is still on the conveyor at the receiving end, (2) ammunition retaining collars have no safety latch to prevent a round from falling to the ground in front of the trailer during loading operations, (3) 155mm ammunition is too heavy and awkward to safely load rounds from the ground into the ARTRAIL with the use of a ladder. In this concept, the ARTRAIL design will be modified to be installed on the 5 ton truck which serves as the prime mover for the M198.

6.7.1 Description of the Concept

The current size of the total trailer is approximately 13.8 feet in length, 10.3 feet in width and height of 7.5 feet. These dimension are too large for the storage case to be installed on the cargo bed of the prime mover. In this concept approximately half of the ARTRAIL storage case will be used. Since this storage system will be mounted on the prime mover, the two wheeled trailer assembly is not required. The dimensions were reduced to a length of 83 inches, width of 62 inches and height of 43 inches.

There are three storage compartments to the case. In the front section, facing towards the rear of the prime mover is the projectile rack compartment. Eighteen projectiles lie on a rack system made up of a series of rollers and spring retainers. The rollers move the projective forward to be lowered onto the conveyor assembly. Figure 14 shows the front section of the projectile rack compartment. The spring retainers secure the 155mm projectile while stored in the ammunition rack. A retaining collar is located at the front of the projectile rack and prevents the round from sliding forward.

At the opposite end of the storage case is the propellant charge compartment. 22 charges are stored in this compartment. And the side compartment will store 4 white phosphorus rounds.

The conveyor assembly used in ARTRAIL is used for resupplying the self-propelled howitzers. For application in towed artillery, the length of the conveyor assembly needs to be increased to around 12 feet. This conveyor assembly is not designed for rearm operations and would be replaced with the Chute concept conveyor in section 6.1 of this report. The conveyor assembly would be stored under the bed of the prime mover.

The compartment case of the ARTRAIL is made of protective armor, composite materials of 7039 and 5083 ballistic aluminum. Since towed artillery has no protective armor for its prime mover, the compartment case for use in this concept could be constructed of lighter materials.

6.7.2 Operations

In rearm operations, this concept is envisioned to rearm the howitzer essentially the same way as in the Chute concept, see section 6.1.4. Here the difference is removing the projectile and the propellant from the storage compartments and placing on the conveyor assembly. This concept provides a dedicated storage rack for the projectiles, charges, fuzes and primers configured to be mounted on a 5 ton truck. Using this rack, all 155mm components are quickly and safely stored; no rolling and shifting of projectiles and propellant canisters, and no more straps to band down the ammunition.

6.7.3 Assumptions

1. The weight of the storage case could be constructed of durable light weight material.
2. The deficiencies listed in the final report, Technical Feasibility Test of ARTRAIL concerning the ammunition storage case can be corrected by adopting the recommendations of the final report.

6.7.4 Advantages

1. A dedicated storage case for projectiles, propellant charges, fuzes and primers for the prime mover.
2. Projectiles and propellant charges are located close to the conveyor assembly. Crew members do not have to carry projectiles to the conveyor.

6.7.6 Disadvantages

1. Using this concept, it may take longer to upload projectiles and propellant charges into the compartment storage case, since each piece of ammunition must be handled individually.
2. Storage compartment must be reduced in size to be mounted on the prime mover. Redesign of the storage compartment involves correcting the deficiencies noted during the Technical Feasibility Test of ARTRAIL.

6.8 Power Tailgate

In this section the power tailgate is considered as a material handing equipment for use on the M198 prime mover.

6.8.1 Description of Concept

Hydraulically powered tailgates would be installed on the prime mover to reduce the manual lifting of Class V supplies. Current and future prime movers would be modified to have a power tailgate operate off the transmission power take off. Operating the power tailgate could be conducted inside the cab of the prime mover or controlled outside the vehicle.

Tank Automotive Command (TACOM) has worked on modifying an Army tactical vehicle to have a power tailgate capability. The Army Medical Service Corps had a requirement to install a power tailgate to the M934, a 5 ton long bed, expandable van. This vehicle with the modifications was designated as the M942. Due to sole source contracting, the M942 was never fielded since the production cost was three times the cost of a commercial market equivalent. Electric tailgates are possible with an onboard auxiliary power unit working off the 24 volt battery system of the prime mover.

In rearm operations, the M198 would be disconnected from the prime mover. In this rearming concept, the projectiles and propellant charges would be placed on the power tailgate. The tailgate would be then lowered to waist level. Crew members would draw ammunition from the tailgate. This would eliminate stockpiling rounds on the ground. Since ammunition is still on the prime mover, projectiles and propellant canisters can be quickly moved back onto the cargo bed.

Resupply at the firing position would be expedited using this concept. The resupply vehicle using its onboard crane, lifts a pallet of projectiles onto the power tailgate. The tailgate is then raised to cargo bed level of the prime mover and supplies are moved forward to the storage locations. Using the power tailgate, crew members do not have to lift projectiles from ground level to the bed of the truck. However, manual lifting is still required to break down the pallet and relocate the projectiles into the cargo bed. Resupply at the LRP using the powered tailgate may not be possible since each firing section drives through the LRP with the M198 connected to the prime mover. The trail legs of the M198 prevent the power tailgate from being lowered. Figure 15 illustrates the M198 connected to the prime mover.

6.8.2 Assumptions

1. Current and future prime movers can be modified to install a hydraulically powered tailgate.
2. Electric powered tailgates can be integrated into the prime mover 24 volt electrical system and have the capability to lift at least two pallets of projectiles.

6.8.3 Advantages

1. Bulk ammunition can be loaded on the power tailgate from a resupply truck using its crane.
2. Resupply operations at the firing position are expedited using the power tailgate.

6.8.4 Disadvantages

1. The prime mover must be disconnected from the M198, before the power tailgate can be used.
2. Cannot be used at LRP when M198 is connected to the prime mover.
3. Modification to the prime mover rear bumpers and brake air lines are required before power tailgate can be installed.

6.9 M198 Loader

This section examines the possibility of installing a removable loader to be used only during the rearm process. The concept would use the existing ammunition loading tray found on the M198. Use of the removable loader would allow only two crew members to arm the howitzer versus the current four crew member process.

6.9.1 Description of the Concept

A removable loader is connected to the left top carriage assembly section of the M198. On the left top carriage assembly there are aluminum weldment fittings that provide the support for the loader to be mounted on the M198. A moveable arm is attached to the fittings. The ammunition loading tray is connected at the other end of the arm. This tray can be adjusted by one crew member to line up the breech opening at various quadrant elevation settings. To support part of the weight a brace runs at a 45 degree angle from the arm to the front part of loader. Figure 16 shows the M198 loader connected to the left top carriage assembly. No power sources are applied in this concept. The end of the tray has a lip that acts as a stop to prevent the projectile from sliding off.

6.9.2 Rearming Operations

When the firing section conducts crew drills to emplace the M198, the loader becomes part of this drill. After the trail legs of the M198 are separated, the loader is removed from its stowed location on the right trail leg. The loader arm is attached to the upper left carriage assembly.

After attachment, the arm is moved to the right to position the tray with the breech. At this position the tray is then raised or lowered to directly line up with the breech opening. The loader is now ready to accept a projectile.

One crew member places a projectile onto the loader. No one is required to hold the loading tray. Once fire mission is ordered, the projectile is rammed by two crew members and the propellant charge is placed. Before breech door is closed, loader is moved up and to the left, out of the way of cannon recoil.

After firing, loader is repositioned in front of the breech opening for the next round to be fired. During march order, loader is returned to its storage brackets on the right trail leg.

6.9.3 Assumptions

1. Permanently installed fittings to the left top carriage will not interfere with the traversing handwheel, the M137 Panoramic Telescope (Pantel) Controls and Indicators, M172 Telescope and Quadrant Mount and M18 Fire Control Quadrant Controls and indicators operations of the M198.
2. There will be a small increase in weight by adding a support arm and brace to the current ammunition loading tray.
3. Loader can be stored in the same location as the existing ammunition loading tray.

6.9.4 Advantages

1. Projectile only has to be lifted once when it leaves the prime mover.
2. Two fewer crew members are required in the rearming process.

6.9.5 Disadvantages

1. Using this concept an additional task of mounting and dismounting the loader must be included in the firing section's crew drills.
2. Manual labor is still required to arm the howitzer.

6.10 ARM II Technology

The Artillery Rearm Module (ARM) II is designed for self-propelled artillery resupply. It consists of four major assemblies: (1) conveyor group, (2) projectile storage, (3) Unicharge storage, and (4) electrical control system.

The conveyor group contains four subassemblies. There are three conveyor subassemblies; hand-off, stub and transfer. A conveyor support system is the fourth subassembly.

The projectile storage unit has two identical modular storage racks. The other subassemblies are the drive, serpentine, and hand-off, with a pallet structure that supports the projectile storage assembly. Current capacity for the storage unit is 64 projectiles.

Unicharge storage unit has a capacity of around 320 unicharges. The magazine dimensions are 144 inches long, by 40 inches wide, by 36 inches in height.

An electrical control system provides the automatic selection, storage and transfer of projectiles and propellant canisters.

6.10.1 Description of the Concept

For application of the ARM II for use in towed artillery this resupply module would be mounted on 5 ton resupply trucks for the Army and Logistic Vehicle Support trucks for the Marine Corps. ARM II in its current size and estimated empty module weight of 5250 pounds when loaded would be too large and heavy for use in the Army's future 5 ton FMTV resupply vehicles. The FMTV has a cargo payload of 10,000 pounds. However, this module can be installed on the current Army HEMTT and the Marine Corps MK48/17 LVS, which have cargo payloads of over 21,000 pounds.

The ARM II module would have to be redesigned to reduce its size and weight to fit on the back of the FMTV. Instead of having two projectile magazines, it would have only one larger magazine.

6.10.2 Resupply Operations

For resupply operations at the LRP, each firing section would position its prime mover to within 102 inches from the resupply vehicle carrying the ARM II module. The conveyor is deployed, which swings out to 90 degrees. Adjustments are made to the conveyor's height, length and azimuth.

Using the remote control handset, type and quantity of projectiles are selected. Selected projectiles are automatically transferred to the prime mover. At this point the projectiles are manually handled and can be either inserted into the loose projectile restraint system or into the ARTRAIL storage case (see section 6.7), or into a ARM II module designed for use in the prime mover (see next section 6.10.3).

After projectiles have been downloaded onto the prime mover, the handset is programmed for downloading unicharge canisters. Lot number and quantities are then selected. Unicharge canisters are automatically transferred to the prime mover. Once on board the prime mover, the canisters are manually handled and stored on a wooden pallet or can be stacked using the modular propelling charge storage rack (see section 6.6).

Using this approach requires that the resupply trucks, remain at the LRP location during the transloading procedure. Army field artillery battalion resupply at a LRP is conducted at platoon level. At least two resupply vehicles would be needed at the LRP to support the resupply of a 4 gun platoon.

6.10.3 Rearm Operations

In this section of the concept, the ARM II module is used in rearming the howitzer. Redesigning a smaller version of the ARM II is needed for mounting the module on the prime mover. As in the FMTV resupply vehicles, this module would have only one projectile storage magazine. The conveyor would have to be changed back to the position used in ARM I. The conveyor needs to deliver projectiles and unicharge canisters from the rear of the prime mover. See Figure 17 for an illustration of a modified ARM II module mounted on the prime mover. In ARM II, the conveyor is positioned to dispense ammunition from the side of the vehicle.

To rearm the towed howitzer, the remote control handset is programmed to download the specified type of projectiles and unicharge canisters as directed from the Fire Direction Center. Projectiles can be delivered from the magazine at an effective rate of 12 projectiles per minute. This rate support the M198 initial rate of fire of 4 per minute. The ammunition travels along the conveyor and stops at the conveyor's load tray. Up to this point, all functions have been fully automated with no manual lifting. When the projectile and canister reach the end of the conveyor, they must be manually lifted off the conveyor and carried either to the current M198 ammunition loading tray located on the ground, or placed on the loader which is attached to the M198, (see section 6.9).

6.10.4 Assumptions

1. Firing section crew members will have room to work on board the cargo bed with redesigned ARM II module mounted on the prime mover.
2. The prime mover with the reduced size ARM II fully loaded with projectiles and unicharge canisters will be able to travel along cross country routes.

6.10.5 Advantages

1. Concept represents the highest level of automation. Projectiles and canisters are automatically selected, stored and transferred without manual lifting.
2. The only lifting of ammunition is when it is removed from the end of the conveyor and carried to the breech to physically arm the howitzer.
3. In resupply operations at the LRP, inventory and disbursement of ammunition is automated and time spent at the LRP location is reduced.
4. In ARM I testing, resupplying 5 ton trucks has been demonstrated.

6.10.6 Disadvantages

1. To modify the ARM II module for use in resupply trucks and on the prime movers, represents significant redesign efforts and greater technical risks.
2. Using this concept for the prime mover greatly reduces the storage space for the remaining firing section equipment.
3. In the event manual backup procedures are used, crew members may not be able to retrieve a specific projectile in time to meet the initial fire rate of 4 rounds per minute.

7.0 COMPARISON OF CONCEPTS

Ten concepts are presented in this report for consideration towards the resupply/rearm operations in a 155mm towed howitzer battalion. These ten concepts range from simple mechanical devices to automated systems. Each concept was evaluated for its contribution to resupply and rearming activities.

The significant activities involving resupply operations occur at the ATP/ASP, LRP locations, and at the firing section. Rearming the howitzer was evaluated as a single activity. Within each activity, a list of factors was developed to illustrate the differences between each concept as it relates to the resupply/rearm activities. Factors used were degree of manual labor, MHE, crew reductions, impact on load plan, and Reliability, Availability, and Maintainability (RAM) factors.

7.1 Resupply at ATP/ASP

This activity is not conducted by the battery firing section. In Army battalions, the Service Battery, and in the Marine Corps, CSS units, are the organizations that travel to the ATP and ASP. The Israeli Artillery Trailer, Power Tailgate,

Chute, Power Conveyor, and Modular Propellant Charge Storage rack are concepts used on the prime mover. Since the prime mover would not make trips to the ATP/ASP, these concepts were not evaluated for resupply activities at the ATP/ASP. The M198 loader is not part of the prime mover or resupply vehicle. It belongs to the howitzer to assist in rearming operations. Drawing Class V supplies in bulk pallet form are major actions performed using the Truck Crane, Straddle Pallet Stacker and the modified ARM II module. Therefore, only these three concepts were compared in this activity.

Using the Truck Crane concept with the Multiple Leg Sling, provides faster and safer transfer of bulk pallets to the resupply vehicles.

The Straddle Pallet Stacker would be used to pick up pallets of ammunition that were out of the reach of the resupply vehicle's crane. This would save time from having the resupply vehicle wait to move into position for the crane to reach the ammunition stockpiles.

The modified ARM II could be used to upload ammunition directly into the its storage magazines. Using this concept, greatly reduces the amount of manual handling and rehandling of ammunition. Comparison of resupply concepts at this activity is shown in Table 1.

Table 1 - RESUPPLY AT ATP / ASP

FUNCTION/ CONCEPT	Degree of Manual Lifting	Type of MHE	Crew Reductions	Impact on Load Plan	RAM Factors	Weight (Pounds)	Size	Cost (Each)	Number Required
Chute	Concept is not used at ATP/ASP								
Power Conveyor	Concept is not used at ATP/ASP								
Truck Crane	Low	Hydraulic	No	Not part of load plan	Medium to high	3,561	98"L x 34"W x 74.25"H	\$45,100	One crane per prime mover
UBL-UE	Medium	Mechanical Pallet Stacker	No	Must be added to load plan	High	757	54"L x 32"W x 96"H	\$2,880	Four per platoon
Forklift	Concept is not used at ATP/ASP								
Modular Rack	Concept is not used at ATP/ASP								
Israeli Trailer	Concept is not used at ATP/ASP								
Power Tailgate	Concept is not used at ATP/ASP								
M198 Loader	Concept is not used at ATP/ASP								
ARM II	Low	Automated electronic system	Yes	Resupply vehicle load plan	Low to medium	6231 loaded	148"L x 84"W x 40"H	\$500K-\$800K	12 in Service Battery

7.2 Resupply at LRP

When the firing sections arrive at the LRP, the howitzer remains attached to the prime mover. Ammunition for the firing section has been placed on ground by either the Army Service Battery or the Marine Corps CSS unit.

The Chute, Power Tailgate and the M198 load tray were not evaluated at this activity. The Chute was not considered since it operates as a gravity driven device. It would be extremely slow in moving large quantities of ammunition from ground level to the bed of the prime mover. Operation of the Power Tailgate is limited, because of interference by the trail legs of the howitzer. The M198 Loader is only used at the firing position during rearm operations.

The Power Conveyor oriented to the left or the right has the ability to convey ammunition up to the prime mover. This involves lifting each individual piece of ammunition and placing it on the conveyor.

The Truck Crane concept used on the resupply vehicle may not be available when the firing sections pass through the LRP. Once resupply trucks have stockpiled the ammunition, these vehicles may be returning to the ATP/ASP to drawn more ammunition. However, designating that each Army FMTV prime mover be equipped with a crane would provide a dedicated heavy lifting capability for each firing section to upload their own ammunition.

The UBL-UE modified Straddle Pallet Stacker or the modified Commercial Stacker is capable of lifting up to 1000 pound pallets from the ground and transporting them to the bed of the prime mover. Using this concept, it may be faster to upload a pallet of projectiles than having to set up slings and extend the boom of the truck crane.

Rough Terrain Lift Trucks operate essentially the same as the Straddle Pallet and Commercial Stackers. In this concept, only one Rough Terrain Lift Truck was allocated per platoon, to be shared by four firing sections. These lift trucks are self-propelled and would be faster than the stackers in transporting the lifted ammunition to the prime mover along rugged terrain.

The Modular Propelling Charge Storage Rack would be used by Service Battery/ Marine CSS to built custom pallets of propelling charges for each firing section. Once constructed, they would be positioned next to the projectile pallets. This concept would be used in conjunction with other concepts that provide a vertical lifting capability.

The Modified Israeli Artillery Trailer would be used at the LRP to store projectiles and propelling charges on the prime mover. In this concept, only the ammunition storage case would be used at the LRP. In section 6.7.2, the Chute

was incorporated into this concept, but is not practical to use at the LRP. The safety and speed of reloading the storage case is the important consideration for use of this concept at the LRP.

A Modified ARM II module mounted on the resupply vehicles of Service Battery and CSS would be used to directly resupply the prime mover at the LRP. Using this concept eliminates the practice of stockpiling ammunition on the ground. At least two Army FMTV resupply vehicles and one Marine LVS, mounted with the modified ARM II module would be required to resupply a platoon. Comparison of resupply concepts at this activity is shown in Table 2.

Table 2 - RESUPPLY AT LRP

FUNCTION/ CONCEPT	Degree of Manual Lifting	Type of MHE	Crew Reductions	Impact on Load Plan	RAM Factors	Weight (Pounds)	Size	Cost (Each)	Number Required
Chute	Concept is not used at LRP								
Power Conveyor	Low to Medium	Hydraulic	No	Yes	Medium	900	15'L x 1' W x 8"H	\$80K- \$120K	1 per prime mover
Truck Crane	Low	Hydraulic	No	Not part of load plan	Medium to High	3,561	98"L x 34"W x 74.25"H	\$45,100	One crane per prime
UBL-JE	Medium	Mechanical Pallet Stacker	No	Must be added to load plan	High	757	54"L x 32"W x 96"H	\$2,880	Four per platoon
Forklift	Low	Hydraulic	No	Trailer load plan	Medium to high	2900-4500	98"L x 31"W x 55"H	\$20K- \$40K	One per platoon
Modular Rack	Medium to high	Retractable straps	No	Yes	High	7-15 per module	45"L x 4"W x 18"H	\$35 per module	8 per prime mover
Israeli Trailer	Medium to high	Gravity driven conveyor	No	Yes	Medium	800-1000	83"L x 62"W x 43"H	\$1500 - \$5000	One per prime mover
Power Tailgate	Concept is not used at LRP								
M198 Loader	Concept is not used at LRP								
ARM II	Low	Automated electrical system	Yes	Resupply trucks	Low to medium	6231 loaded	148"L x 84"W x 40"H	\$500K- \$800K	12 in Service Battery

7.3 Resupply at Firing Section

Resupply at the firing section involves Service Battery/Combat Service Support delivering Class V to the gun position. Nine concepts were evaluated at this activity. Ammunition is off-loaded using the Truck Crane, Forklift, Straddle Pallet Stacker, Chute and Power Conveyor. Concepts used for uploading are the Power Conveyor, Forklift, Straddle Pallet Stacker, Modular Rack, Israeli Artillery Trailer, Power Tailgate, and ARM II. The M198 Load Tray is the only concept not used in this activity, since it is not used in the resupply process.

The Chute can be used only when ammunition is transloaded from the resupply vehicle to the prime mover. The distance between resupply vehicle and the prime mover must be within length of the chute. If the resupply vehicle off-loads the ammunition to the ground, then this option would not be used.

The Power Conveyor can be used like the Chute to transload ammunition between vehicles. Ammunition that is off-loaded to the ground must be picked up individually and placed on the conveyor to be sent up to the prime mover.

The Truck Crane concept for delivering ammunition onto the bed of the prime mover is dependent on whether the resupply vehicle has the time to perform this task.

Modified UBL-UE/Commercial Stackers belong to Service Battery/CSS. As in the Truck Crane concept, their availability is questionable in being used to upload ammunition onto the prime mover.

Rough Terrain Lift Trucks belong to the platoon and would be available for uploading ammunition that was stockpiled by Service Battery/CSS. This concept is being considered for adoption by the Army, since each Marine towed howitzer battery has two rough terrain lift trucks. These lift trucks would be able to negotiate rough terrain and provide dedicated support between four firing sections.

The Modular Propelling Charge Storage Rack concept could be used by itself or along with other concepts that lift pallets of ammunition. Custom built propellant charge pallets would be lifted onto the bed of the prime mover. In the event that Service Battery/CSS did not have the time to construct custom propellant pallets, then the concept could still be used to rebuild depleted propellant storage racks onboard the prime mover.

The Modified Israeli Artillery Trailer would be used the same way as in resupply operations at the LRP.

The Power Tailgate would be used to lift ammunition and other organizational equipment to the cargo bed level of the prime mover. For this concept to save time and manual labor, the ammunition must be spotted on the ground next to the tail gate. Ammunition must be positioned on the lowered tailgate before it can be raised to the bed of the vehicle.

The Modified ARM II module would be used the same way as in resupply operations at the LRP. Comparison of resupply concepts at this activity is shown in Table 3.

Table 3 - RESUPPLY AT THE FIRING SECTION

FUNCTION/ CONCEPT	Degree of Manual Lifting	Type of MHE	Crew Reductions	Impact on Load Plan	RAM Factors	Weight (Pounds)	Size	Cost (Each)	Number Required
Chute	Low to medium	Gravity driven / mechanical	No	None	High	190-225	12'L x 1' W x 4"H	\$645	One per prime mover
Power Conveyor	Low to medium	Hydraulic	No	Yes	Medium	900	15'L x 1' W x 8"H	\$80K- \$120K	One per prime mover
Truck Crane	Low	Hydraulic	No	Not part of load plan	Medium to high	3,561	98"L x 34"W x 74.25"H	\$45,100	One crane per prime
UBL-UE	Medium to low	Mechanical Pallet Stacker	No	Must be added to load plan	High	757	54"L x 32"W x 96"H	\$2,880	Four per platoon
Forklift	Low	Hydraulic	No	Trailer load plan	Medium to high	2900- 4500	98"L x 31"W x 55"H	\$20K- \$40K	One per platoon
Modular Rack	Medium to high	Retractable straps	No	Yes	High	7-15 per module	45"L x 4"W x 18"H	\$35 per module	8 per prime mover
Israeli Trailer	Medium to high	Gravity driven conveyor	No	Yes	Medium	800-1000	83"L x 62"W x 43"H	\$1500 - \$5000	One per prime mover
Power Tailgate	Medium	Hydraulic/electric	No	No	Medium to high	300-500	98"L x 3"W x 35.5"H	\$35K- \$45K	One per prime mover
M198 Loader	Concept not used in resupply operations								
ARM II	Low	Automated electrical system	Yes	Prime mover & resupply truck	Low to medium	6231 loaded	148"Lx 84"W x 40"H	\$500K- \$800K	12 in Service

7.4 Rearming the Howitzer

Actions conducted when rearming the howitzer consist of taking the 155mm projectile, propellant charge and fuze from the prime mover and moving these components to the howitzer tube. The Chute, Power Conveyor, Modular Rack, Israeli Artillery Trailer, Power Tailgate, ARM II and the M198 Loader Tray Concepts are used in moving these components. Six of these concepts use the prime mover; the M198 loader is independent of the prime mover.

The Truck Crane, UBL-UE, and Rough Terrain Lift Trucks are not used during rearming the howitzer.

The Chute moves ammunition from the bed of the truck to within 7 feet of the howitzer's breech at about waist level.

Using the Power Conveyor system, crew members take projectiles from the projectile storage racks and place them on the conveyor which transports them to within 7 feet from the breech.

Crew members draw propellant charges from the Modular Propellant Charge Storage Rack. Having a built in strap restraint system, keeps canisters from rolling around the bed of the prime mover.

The Modified Israeli Artillery Trailer ammunition storage case keeps projectiles and propellant charge canisters secure and organized. Developing a storage pattern, crew members could quickly select and draw the requested type of ammunition for the next fire mission. This storage case would keep the ammunition clean and protected from the outside elements.

The Power Tailgate could be used as a work platform to prepare the rounds before moving forward to the howitzer. The Power Tailgate would have to be longer than the existing manual tailgates on 5 ton vehicles. The tailgate would be lowered to shoulder height of the crew members carrying the projectile to the ammunition loading tray.

The M198 Loader is used to directly arm the howitzer. Manual labor is still required. Instead of placing the ammunition load tray on the ground, the tray is connected to the left top carriage assembly. Loading the projectile into the breech is conducted using two fewer crew members. Instead of placing the projectile on the ammunition loading tray on the ground, one crew member can carry the projectile onto the M198 Loader. Once on the M198 Loader the projectile does not have to be supported for ramming. The crew member who placed the projectile on the M198 Loader is joined by one other crew member to ram the projectile into the breech.

For use in the rearming process, the Modified ARM II module would be designed differently than for use by Service Battery / CSS. The conveyor system would have to be facing the rear of the prime mover in order to dispense rounds toward the howitzer. This design would be like the earlier ARM I version. This concept represents the highest level of automation. Both projectiles and propellant canisters are automatically selected, accounted for, and transferred to the conveyor without manual lifting. At the end of the conveyor, ammunition must be manually lifted off the conveyor and carried to the ammunition loading tray on the ground or to the M198 Loader. A comparison of the concepts used in the rearming process is at Table 4.

Table 4 - REARMING THE HOWITZER

FUNCTION/ CONCEPT	Degree of Manual Lifting	Type of MHE	Crew Reductions	Impact on Load Plan	RAM Factors	Weight (Pounds)	Size	Cost (Each)	Number Required
Chute	Low to medium	Gravity driven / mechanical	No	None	High	190-225	12'L x 1' W x 4"H	\$645	One per prime
Power Conveyor	Low to medium	Hydraulic	No	Yes	Medium	900	15'L x 1' W x 8"H	\$80K- \$120K	One per prime
Truck Crane	Concept not used during the rearming operations								
UBL-UE	Concept not used during the rearming operations								
Forklift	Concept not used during the rearming operations								
Modular Rack	Medium to high	Retractable straps	No	Yes	High	7-15 per module	45"L x 4"W x 18"H	\$35 per module	8 per prime mover
Israeli Trailer	Medium to high	Gravity driven conveyor	No	Yes	Medium	800-1000	83"L x 62"W x 43"H	\$1500 - \$5000	One per prime
Power Tailgate	Medium	Hydraulic/electric	No	No	Medium to high	300-500	98"L x 3"W x 35.5"H	\$35K- \$45K	One per prime
M198 Loader	Low to medium	Mechanical load tray	Yes	M198 trail leg	Medium to high	30-45	40"L x 18"W x 6"H	\$500- \$1000	One per M198
ARM II	Low	Automated electrical system	Yes	Prime mover	Low to medium	6231 loaded	148"L x 84"W x 40"H	\$500K- \$800K	One per prime

8.0 RECOMMENDED CONCEPT

Ten concepts to assist soldiers and marines in the resupply and rearming operations of a towed 155mm howitzer battery were developed and analyzed. None of the ten concepts can stand alone nor be recommended as the most significant concept to pursue. Some concepts do not compete with each other since their functions are unrelated. The M198 Loader and the Modular Propelling Charge Storage Rack have different functions in assisting the crew members. Recommendations will be presented by significant activity as addressed in Comparison of Concepts, Section 7 of this report.

8.1 Recommended Concept for Resupply at ATP/ASP

The recommended concept(s) at the ATP/ASP would provide the crew of the resupply vehicle with the fastest means to upload ammunition. Speed is important at these locations in order to return and resupply the firing batteries as soon as possible.

The truck cranes used on the HEMTT, LVS and the future FMTV are in the Army and Marine Corps inventories. These vehicles would make repeated trips to the ATP/ASP. Recommend that users of all three vehicles make use of the Multiple Leg Sling. Bulk pallets can be loaded quickly and safely using this sling. For the long term solution, equip the resupply vehicles with the modified ARM II module. This concept would save time from having to rehandle bulk ammunition once the resupply vehicles have departed the ATP/ASP.

8.2 Recommended Concept for Resupply at LRP

The recommended concept(s) for this activity would provide the greatest reduction of individual lifting in stockpiling ammunition on the ground and for each firing section to upload their ammunition to the prime mover. Here, speed to quickly upload ammunition is important in order to reduce the amount of time each platoon spends at the LRP. Providing each firing section with an ability to be self-sufficient to upload their ammunition stockpile would help to reduce the time at the LRP.

Recommend that each Army FMTV prime mover be equipped with a crane. This would provide a dedicated heavy lifting capability for each firing section to upload their own ammunition.

8.3 Recommended Concept for Resupply at the Firing Section

The recommended concept(s) at this activity would have to provide the same benefits that are needed at the LRP. Having the ability to quickly lift ammunition

and carry it up to the bed of the prime mover would save time and greatly reduce the amount of manual lifting by the crew members.

Recommend that the FMTV equipped with a crane be selected as prime mover. Using the crane at the firing position would represent a cultural change in how crew members work around their prime mover both for resupply and during firing missions. Adapting to having the crane at the rear of the prime mover would have to be resolved through training. Using the FMTV with its drop side railings provides two locations to access equipment on the prime mover instead of working from the rear of the vehicle. FMTV representatives have no future plans to relocate their crane to another location on the vehicle. The prime mover could be parked perpendicular to the M198. This would allow other concepts to be used in conjunction with the crane.

8.4 Recommended Concept for Rearm at the Firing Section

The concept that provides the crew member with the ability to quickly select a projectile and propellant charge, and move the ammunition to the breech, while reducing the amount of manual lifting is needed at this activity. The future battlefield will require rapid rearming for ATCAS to be able to fire up to 6 rounds per minute.

For a short term solution, using the Chute and the M198 Loader would assist in reducing fatigue when rearming the M198. The Chute reduces the distance a crew member must carry the projectiles, to within 7 feet of the breech at waist level. Using the M198 Loader, the amount of manual labor to rearm the howitzer is reduced as only two crew members are needed to arm the howitzer. Labor exerted is selecting the projectile and propellant charge, placing it on the Chute, lifting the ammunition at the end of the chute and walking seven or more feet to place it on the M198 Loader.

Recommend that the redesigned ARM II module as stated in section 6.10.3 of this report be the long term solution. This concept would probably come on line about the same time ATCAS. Speed, accuracy, storage protection and accountability of moving ammunition is vital for survivability on the future battlefield. Tasks that are practiced today must be streamlined in order for each firing section to emplace, fire and relocate. Several moves may be required to provide prompt and effective fire support to friendly forces on the battlefield. Using this concept reduces the repetitious rehandling of ammunition and the time spent at each battle position.

8.5 Recommended Concept for Overall Resupply Operations

Recommend the FMTV prime mover with crane using the Multiple Leg Sling as the best overall combination for resupply operations.

8.6 Recommended Concept for Overall Rearm Operations

Recommend that the redesigned ARM II module be used as the best overall concept for rearm operations in conjunction with the M198 Loader.

9.0 CONCLUSIONS

The recommended concepts for each of the four significant activities are products of achieving the balance of conducting resupply and rearming operation given the constraints of the prime mover in towed artillery. Of the ten concepts presented, all ten could be applied to ATCAS when it is fielded.

Since in towed artillery there is a separation of the howitzer from its prime mover, there will always be manual lifting by the crew members. Due to the gun's recoil, the study could not develop a concept that would create a dedicated link between the prime mover and the howitzer. Thus, it appears that there will always be a man in the loop when rearming the gun. The concepts presented were designed to reduce the amount of manual lifting by the crew members. In each concept, there is a degree of manual labor to move ammunition.

Most of the concepts revolved around the prime mover. Those concepts adopted would not assist the firing section during an air assault mission when the gun is inserted to a battle position without its prime mover.

Some of the concepts are derived from existing off-the-shelf items and required modification for use by the towed artillery, i.e., the pallet stackers, boom attachment, Israeli Artillery Trailer, UBL-UE and the Power Conveyor. Four of the ten concepts have not been produced; the Chute, M198 Loader, ARM II and the Modular Propellant Charge Storage Rack.

This report provides concepts that would save time during the resupply operations at the ATP/ASP, LRP and at the firing position. These concepts were design to reduce the amount of handling of individual pieces of ammunition. Tactics was considered in the reduced time to occupy future battle positions. Concepts had to be implemented quickly during preparation of the battle position otherwise the firing section would not use the concept.

New package designs for ammunition are being developed to reduce the time and labor involved in delivering ammunition from the logistics system to the weapon system. Advances in redesigning ammunition packaging are focused on ease of handling and opening, reduced cube and weight, durability and decontaminability. Future ammunition containers will reduce the amount of packaging materials that are discarded and emphasize reusability. Containers such as the Field Artillery Projectile Pallet (FAAP) eliminate the need to cut

metal bands and discard the wooden pallet. Such efforts will contribute to reducing the time and effort involved in rearm/resupply operations of a towed howitzer battery. These packaging improvements will serve to enhance the ten concepts presented in this report.

Once an appropriate concept(s) is (are) selected, a plan should be developed to further explore the concept. During the conceptual design phase, a scenario could be developed for use in a combat model. Results of the modeling runs would uncover areas of uncertainty, requiring further development and/or testing to answer design questions. Concepts that require long term development like the ARM II could be included in the ATCAS 's Analytical Testbed.

ANNEX A

LIST OF FIGURES

- Fig. 1. Chute in Rearming Operations
- Fig. 2. Chute in Resupply Operations
- Fig. 3. M992 Hardware Components.
- Fig. 4. Power Conveyor in Rearming Operations
- Fig. 5. FMTV Models with MHE
- Fig. 6. FMTV Prime Mover Candidates
- Fig. 7. Multiple Leg Sling
- Fig. 8. Unit Basic Load-Upload Equipment (UBL-UE).
- Fig. 9. Commercial Stackers
- Fig. 10. Unit Rough Terrain Lift Truck
- Fig. 11. Modified Sling
- Fig. 12. Boom Lift Attachment
- Fig. 13. Modular Propelling Charge Storage Rack
- Fig. 14. Israeli Artillery Trailer Modification to 5 Ton Truck
- Fig. 15. 5 Ton Truck Tailgate Section
- Fig. 16. M198 Loader
- Fig. 17. Prime Mover Mounted with Modified ARM II Module

FIG. 2. Chute in Resupply Operations

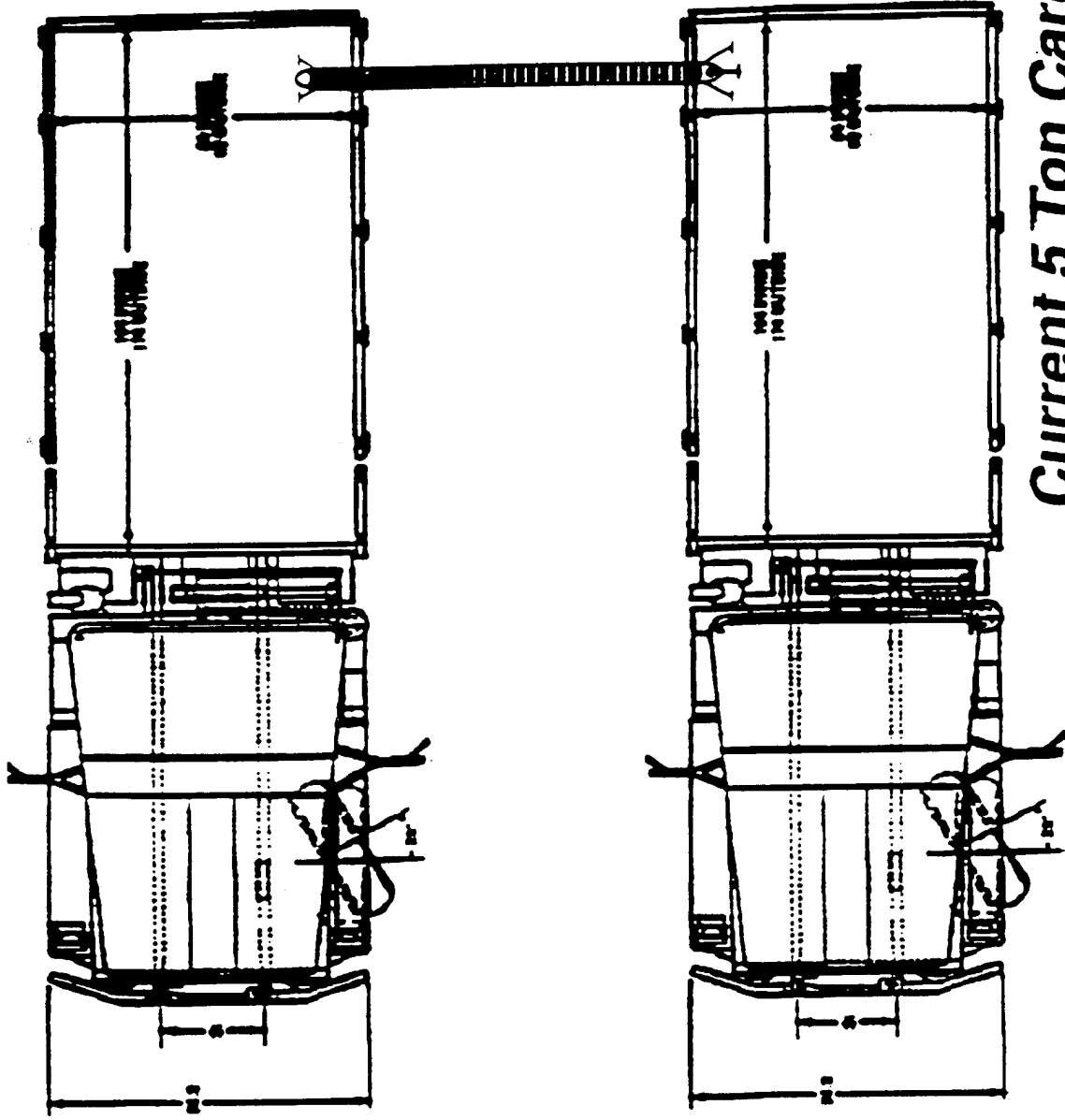

**Current 5 Ton Cargo
M932A2 WO/W and M925A2 W/W**

ILLUSTRATION NOT TO SCALE

FIG. 3. M992 Hardware Components

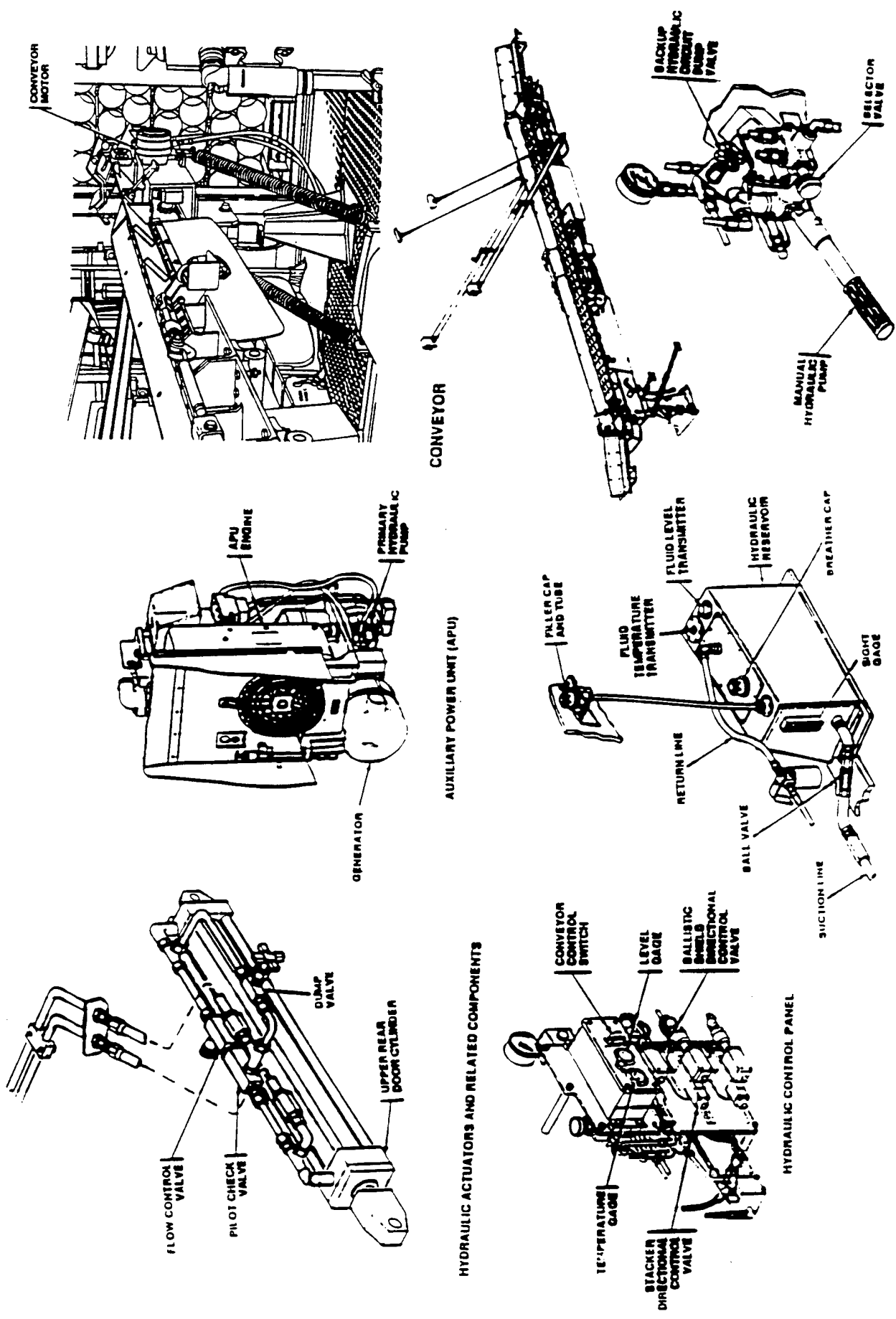
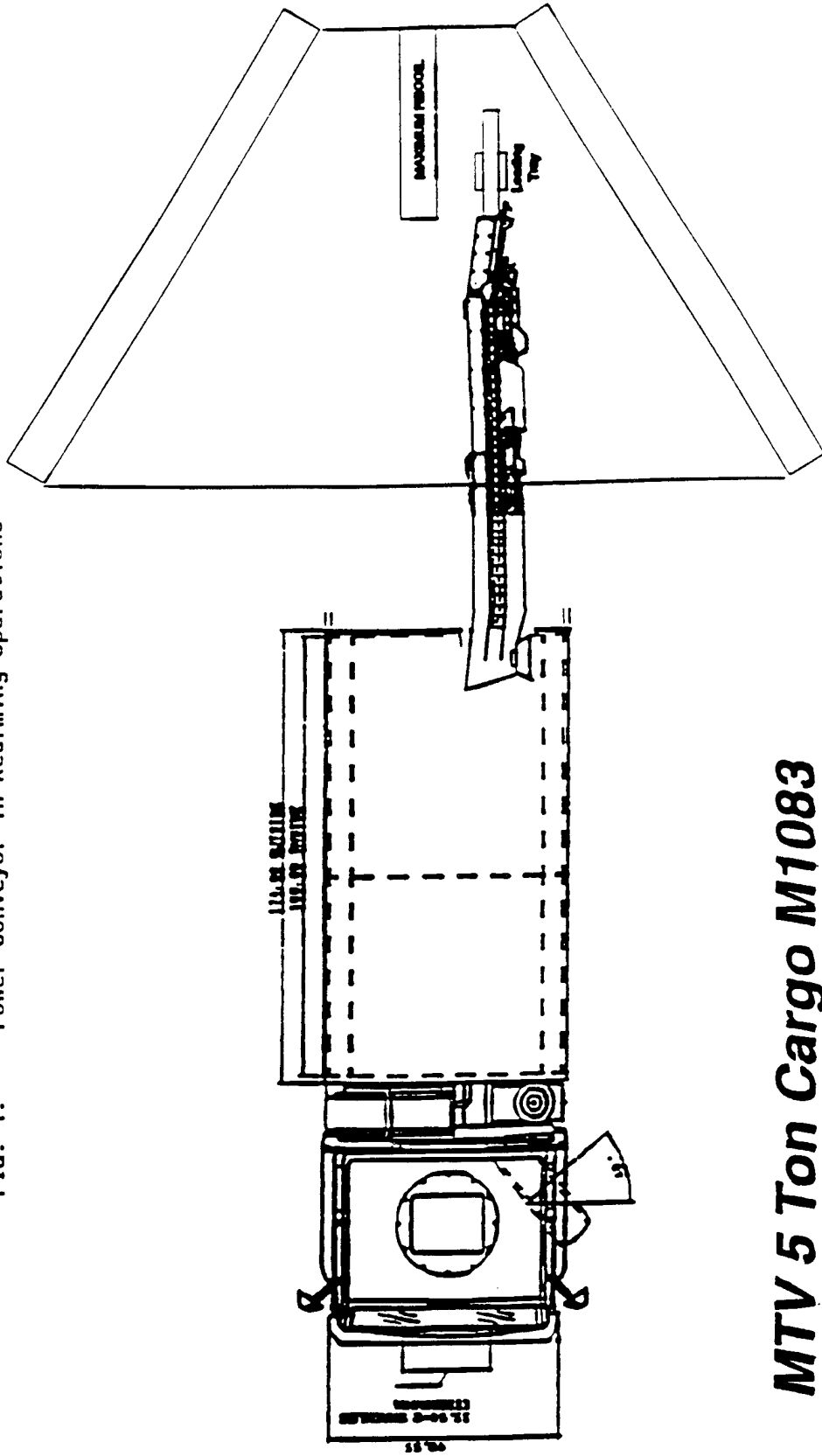

ILLUSTRATION NOT TO SCALE

FIG. 4. Power Conveyor in Rearming Operations



MTV 5 Ton Cargo M1083

ILLUSTRATION NOT TO SCALE

FIG. 5. FMTV Models with MHE

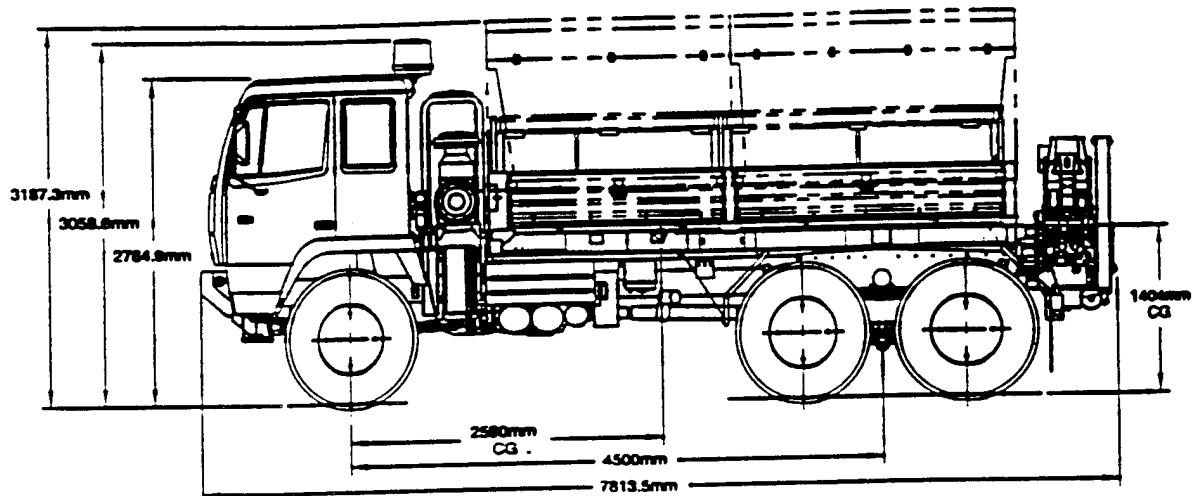

Vehicle ModelM1084

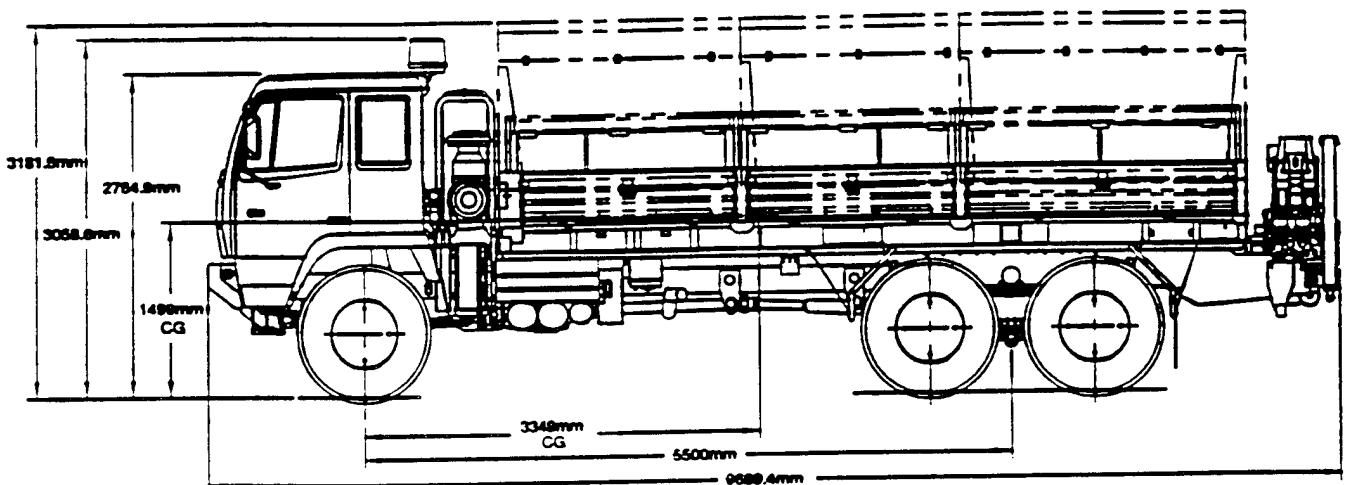

Vehicle ModelM1086

Basic Vehicle Information

- Drive 6 x 6 (full-time)
- Engine Diesel, EPA compliant, 290 hp
- Transmission Fully automatic
- Axles Single reduction with
outboard planetaries
- Cab 3-Man, cab-over-engine
- Tires Super singles with CTIS

FIG. 6. FMTV Prime Mover Candidates

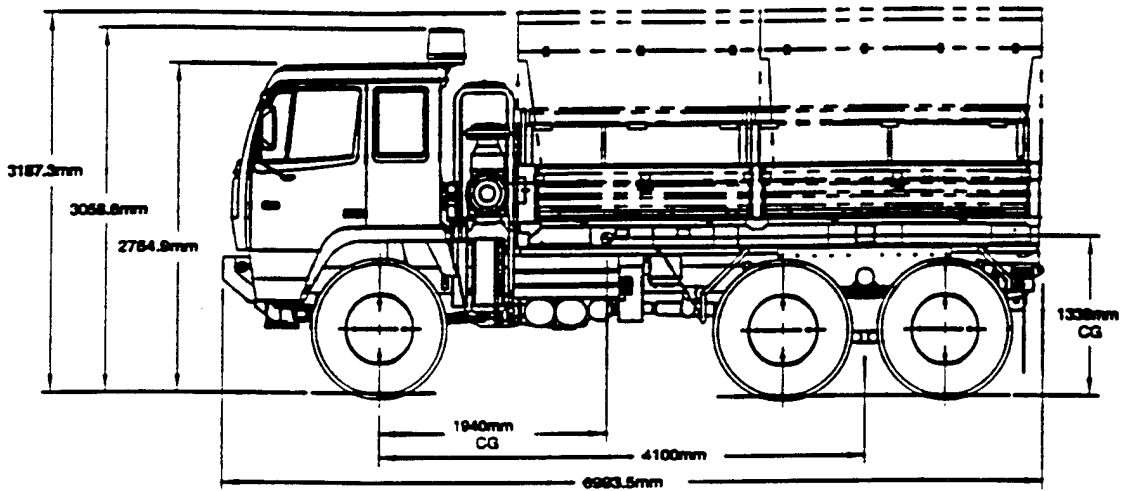

Vehicle ModelM1083

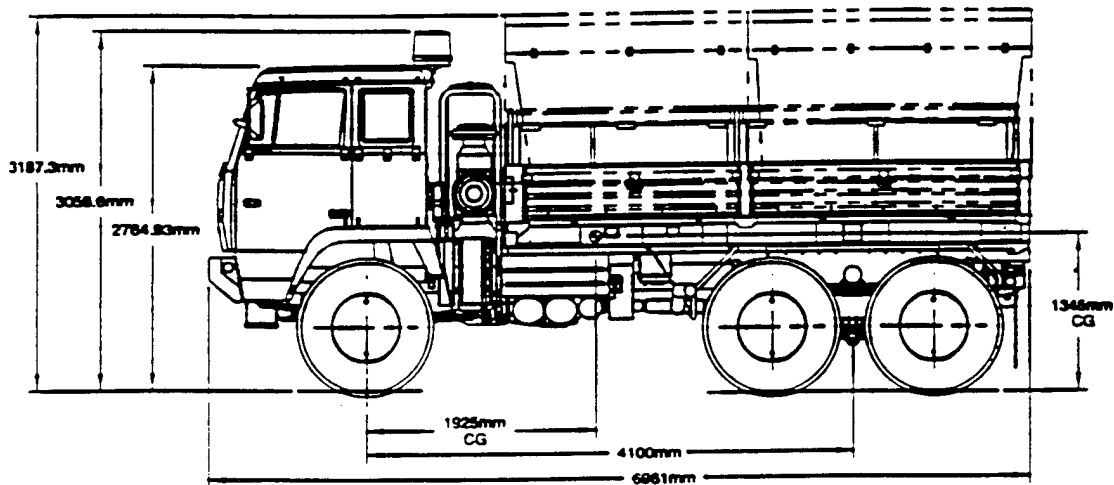

Vehicle ModelM1093

Basic Vehicle Information

- Drive6 x 6 (full-time)
- EngineDiesel, EPA compliant, 290 hp
- TransmissionFully automatic
- AxlesSingle reduction with outboard planetaries
- Cab3-Man, cab-over-engine
- TiresSuper singles with CTIS

FIG. 7. Multiple Leg Sling

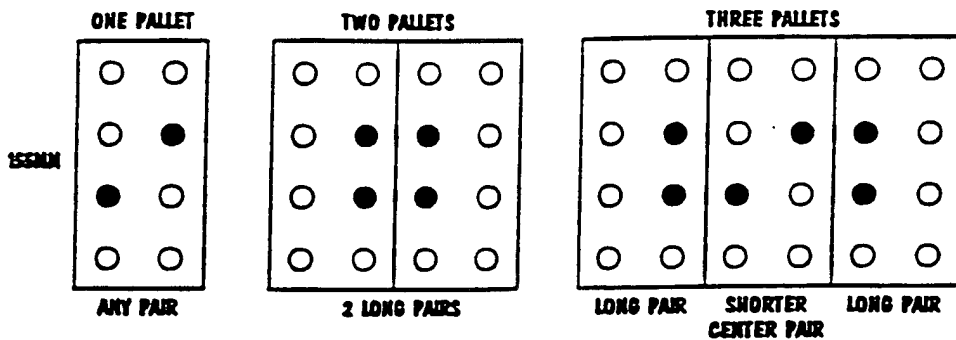
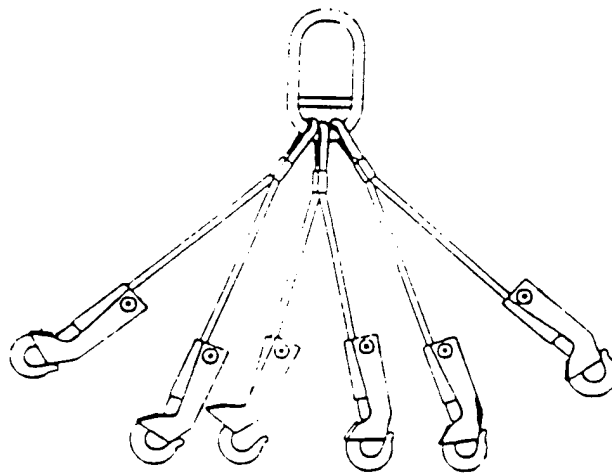

NOTE HOOK PATTERNS SHOWN HERE.
 ○ INDICATES PROJECTILE LIFTING PLUGS, ● INDICATES HOOKS.

FIG. 8. Unit Basic Load-Upload Equipment (UBL-UE)

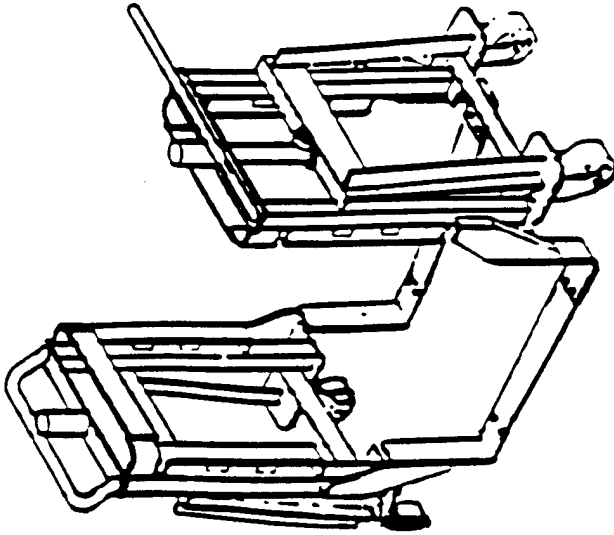

PALLET MOBILIZER
(NSN 3920-01-288-9739)

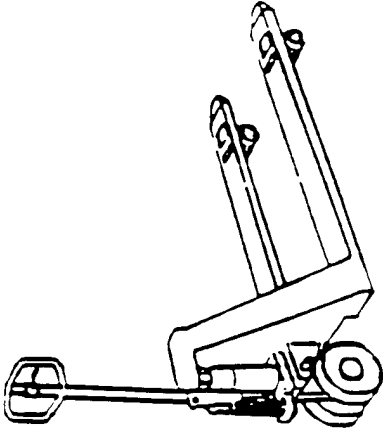

PALLET TRUCK (JACK)
(NSN 3920-01-258-1213)

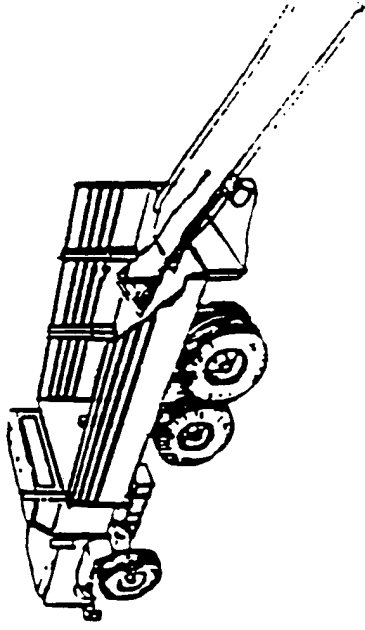

* ALUMINUM RAMP (16 FT.)
* ELECTRIC CAPSTAN (24V)
* JIB BOOMS (W/MOUNTING BRACKET)
* (NSN 3990-01-283-4548)

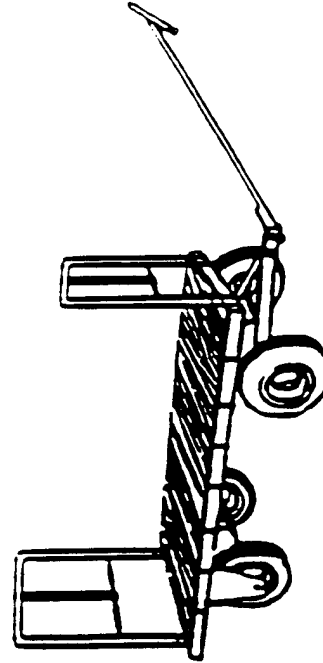

WAGON TRUCK
(NSN 3920-01-257-5095)

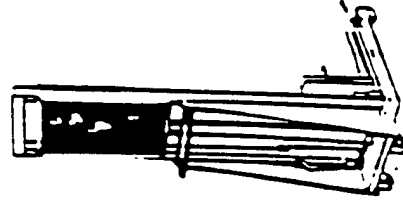

STRADDLE PALLET STACKER
(NSN 3920-01-257-5094)

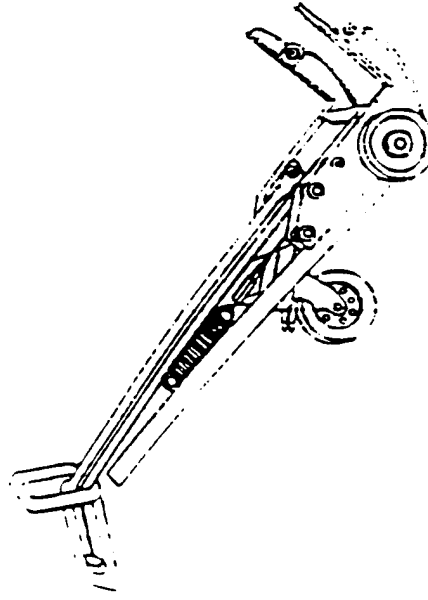

PROJECTILE PALLET HAND TRUCK
FOR 155MM & PROJECTILE
(NSN 3920-01-276-7662)

ILLUSTRATION NOT TO SCALE

FIG. 9. Commercial Stackers

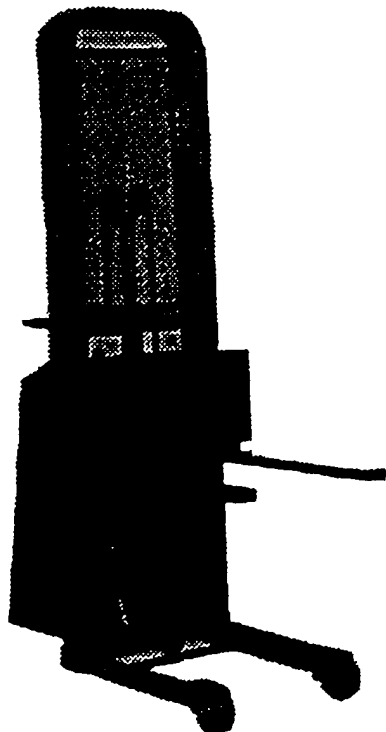

BATTERY

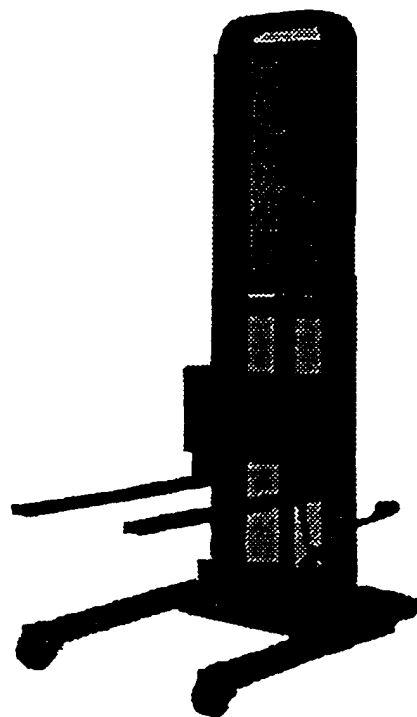

FOOT PUMP

FIG. 10. UNIT ROUGH TERRAIN LIFT TRUCK

MODEL 800 SPECIFICATIONS

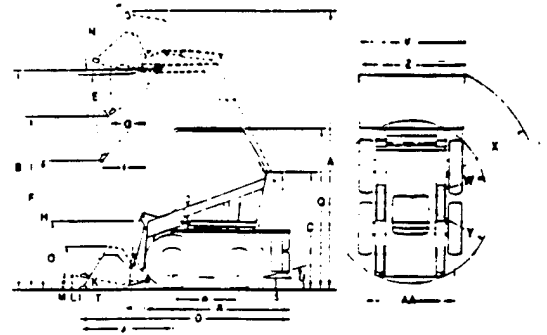

ENGINES — CHOICE OF TWO

Series 818 Diesel, 18 hp., 2 cyl., 45.8 C.I.D. liquid cooled
YANMAR.
 Series 825 gas, 25 hp., 2 cyl., 60 C.I.D. air cooled. **ONAN.**

PERFORMANCE

Lift Rating	800 lbs.
Tip Capacity	1600 lbs.
Breakout Force	1600 lbs.
Hydraulic Lift Capacity	2108 lbs.
Raise Time (Full Load)	4.7 sec.
Lowering Time/Power Down	3.5 sec.
Float Down	4.5 sec.
Dump Time	1.25 sec.
Rollback Time	1.8 sec.
Operating Wt. w Std. Bucket	2900 lbs.
Travel Speed	0-5 MPH

ELECTRICAL

Battery	12V 53 Amp Hrs.
Starter	Solenoid Shift
Alternator	Onan/15 Amp. Yanmar 20 Amp.

DRIVE SYSTEM

Type	Variable Displacement Hydrostatic
Direction	Forward and Reverse
Speed Control	Variable Displacement Pump
Reductions	Single Reduction Roller Chain

HYDRAULIC SYSTEM

Pump Variable Displacement, tandem pump with 3 sections: 2 piston type at 18 GPM, 1 gear type at 8.5 GPM.	
Governor Speed (No Load)	Onan/3600 rpm. Yanmar 3150 rpm
Relief Pressure Lift & Tilt	1500 PSI
Relief Pressure Drive	2000 PSI
Filters: 100 mesh sump strainer w/oil cooler and 10 micron, full-flow, return-line filter	
System Capacity	7 Gallons
Cylinders	2" bore x 1" ram, double action
Drive Motors	Lo speed Hi torque, hydraulic
Tanks Fuel HYDR. All welded steel independently mounted to frame.	

A. Height with lift arms in raised position	124"
B. Height to hinge pin	95 1/4"
C. Overall height	55"
D. Overall length with bucket	98"
E. Maximum dump angle	46°
F. Dump height, 45° standard bucket	72 1/4"
G. Reach at maximum height and 45° dump angle	20"
H. Specified height	51 1/2"
I. Reach at specified height	21 1/2"
J. Reach with bucket on ground	43"
K. Maximum rollback at ground	27°
L. Carry position	13 1/2"
M. Maximum rollback w/ carry position	28°
N. Maximum rollback (fully raised)	99°
O. Height to seat	32"
P. Wheelbase	31"
Q. Overall height with operator guard (standard or ROPS/FOPS)	72 1/2"
R. Overall length less bucket	71"
S. Ground clearance	6 1/2"
T. Maximum grading angle	94°
U. Angle of departure	30°
V. Bucket widths (varies with tire selection)	42" or 48"
W. Clearance circle front (less bucket)	33"
X. Clearance circle front (with bucket)	62"
Y. Clearance circle rear	42"
Z. Overall widths less bucket with standard tires	42" w/flotation tires
AA Tread	38"

STANDARD EQUIPMENT

Tires: 5.70 x 15, 4-ply tubeless—
 42" machine width
 27 — 8.50, 15 flotation —
 48" machine width

Load Arm Safety Lock, ROPS/FOPS Operator Guard, Neutral Safety Start, Hourmeter, Adj. Seat w/Seat Belt, Key Ignition Switch, H.D. Air Cleaner, Fuel Filter, Fuel Gauge, Operator Heat Shield, 230 lb. Cast Swing-Away Counterweights (2), Ammeter and parking brake.

OPTIONAL EQUIPMENT

Buckets (6 Cu. Ft. or 10 Cu. Ft.) Post Hole Auger, Snow Blowers, Manure Fork, Pallet Fork, Light Kits, Horn Kit and View-All Vinyl Cab.

FIG. 11. Modified Sling

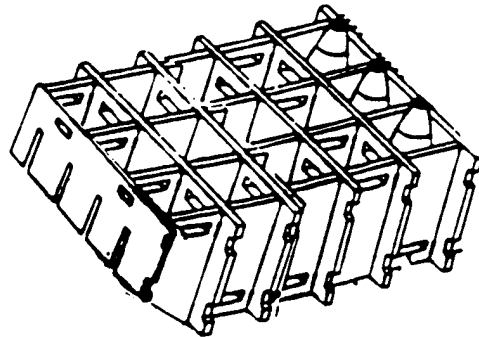
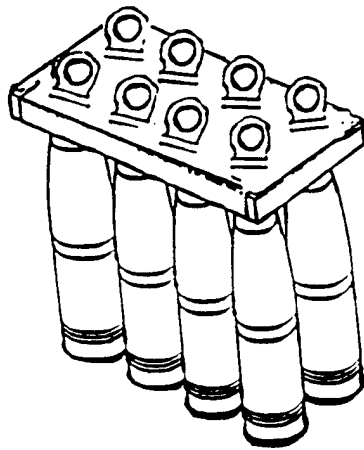
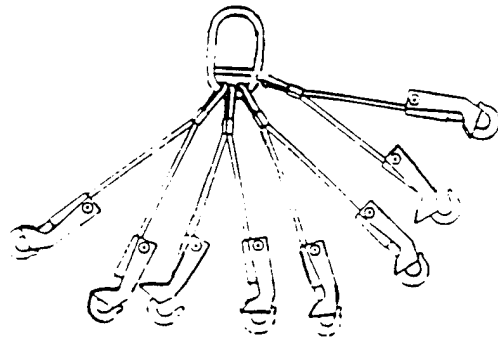
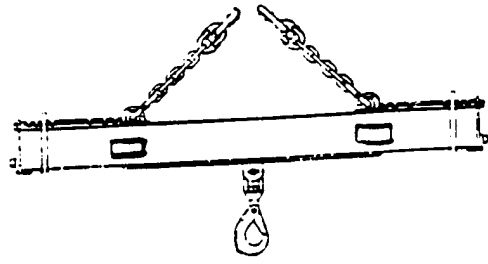

ILLUSTRATION NOT TO SCALE

FIG. 12. Boom Lift Attachment

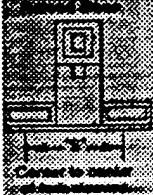
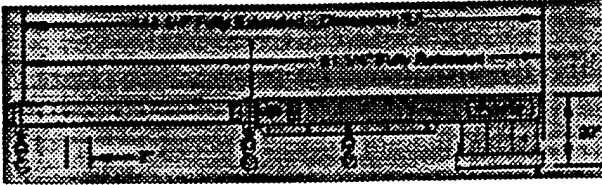
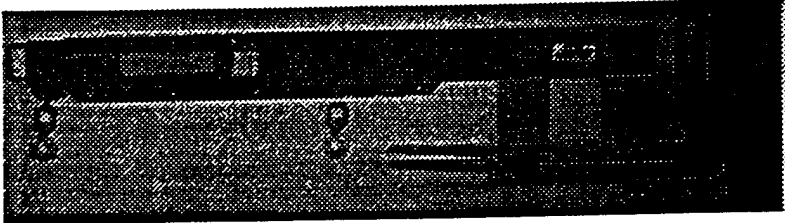

ILLUSTRATION NOT TO SCALE

FIG. 13. Modular Propelling Charge Storage Rack

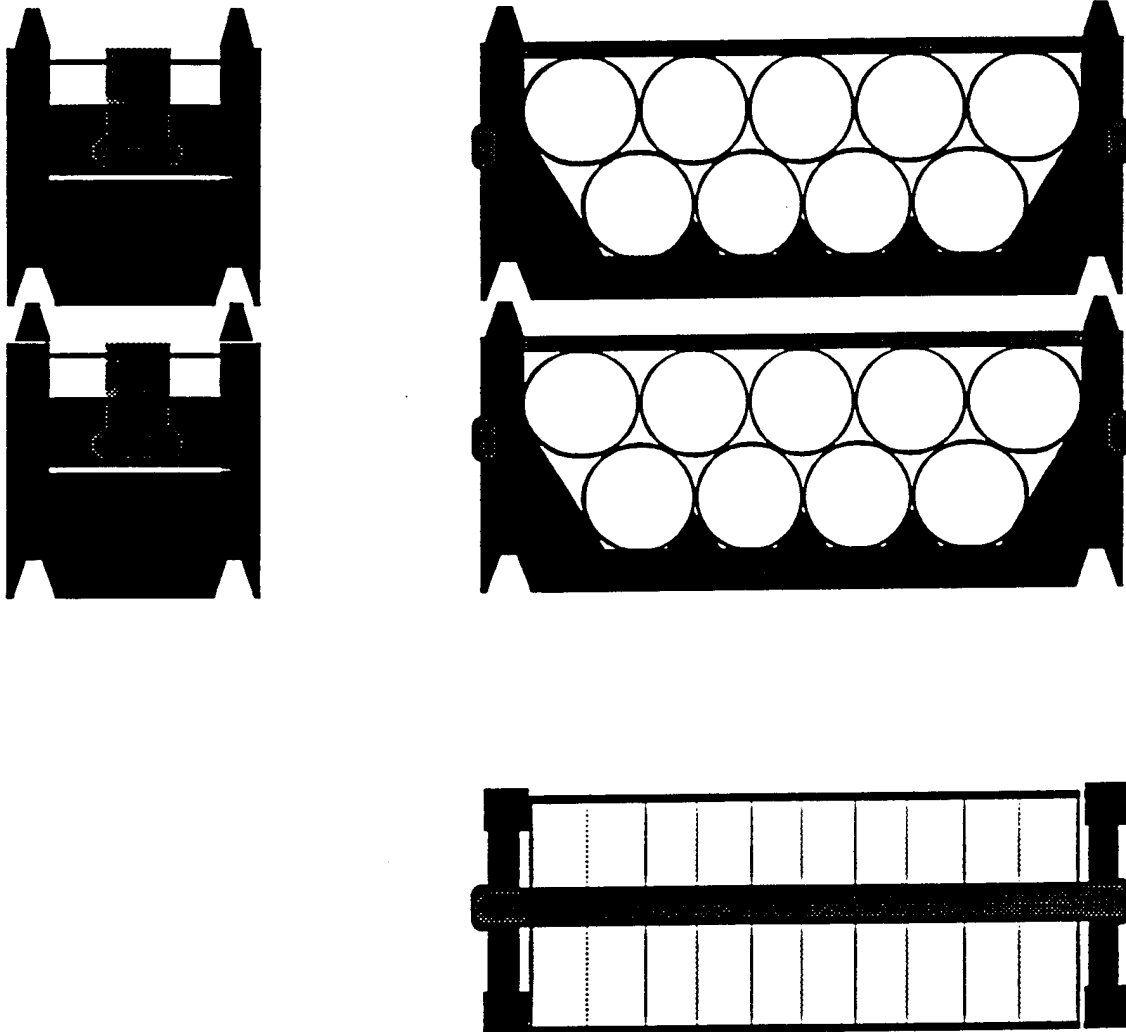

ILLUSTRATION NOT TO SCALE

FIG. 14. ISRAELI ARTILLERY TRAILER MODIFICATION TO 5-TON TRUCK

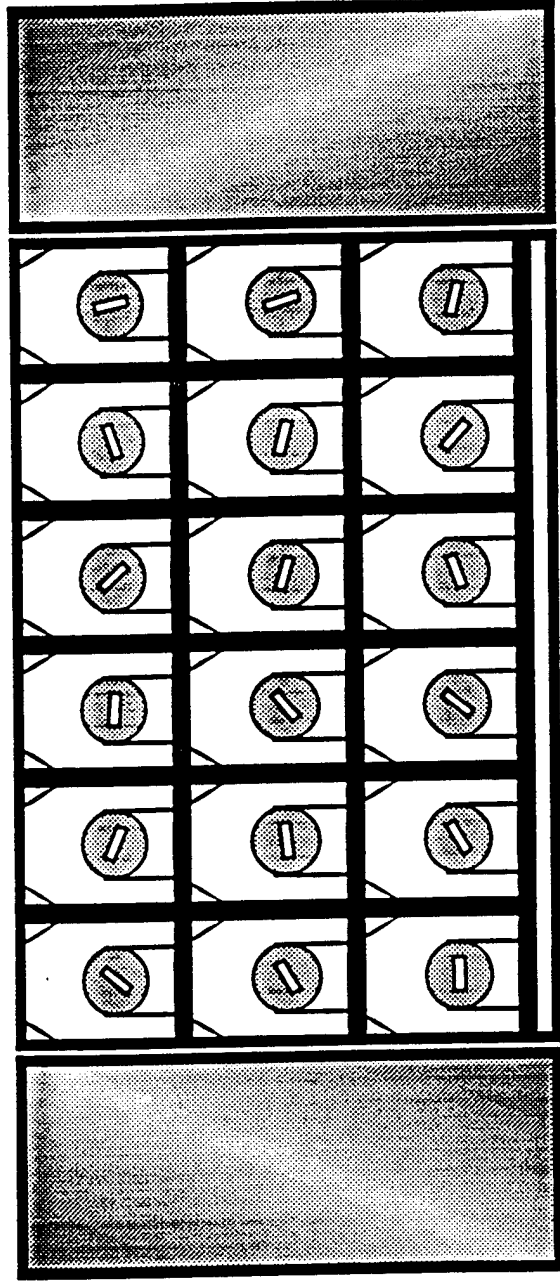

ILLUSTRATION NOT TO SCALE

FIG. 15. 5-TON TRUCK TAILGATE SECTION

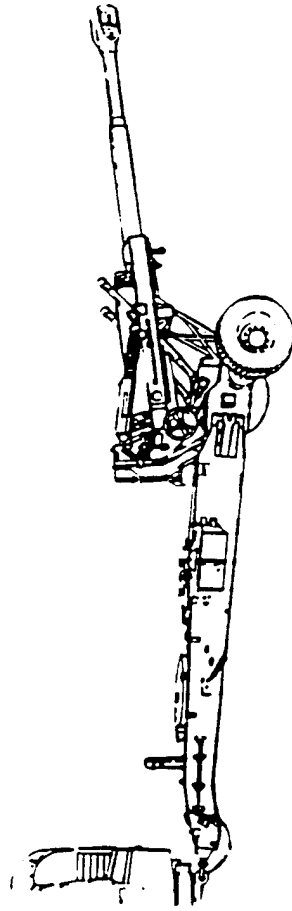
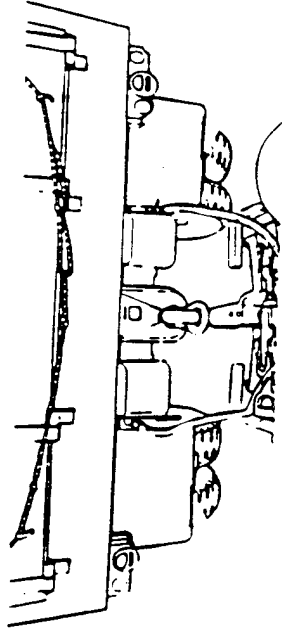

ILLUSTRATION NOT TO SCALE

FIG. 16. M198 LOADER

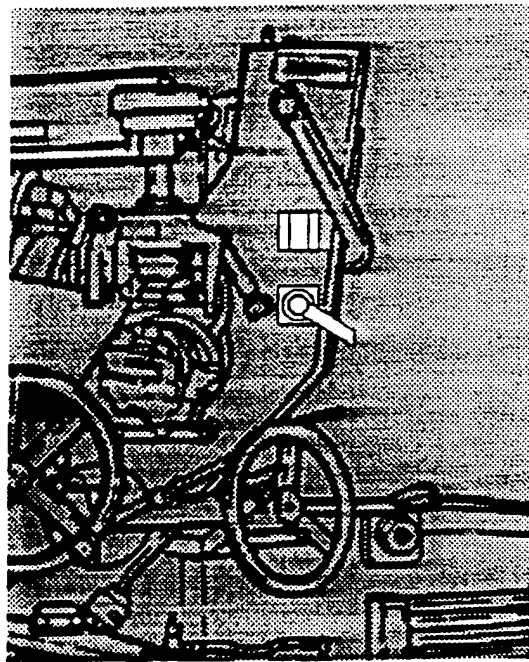
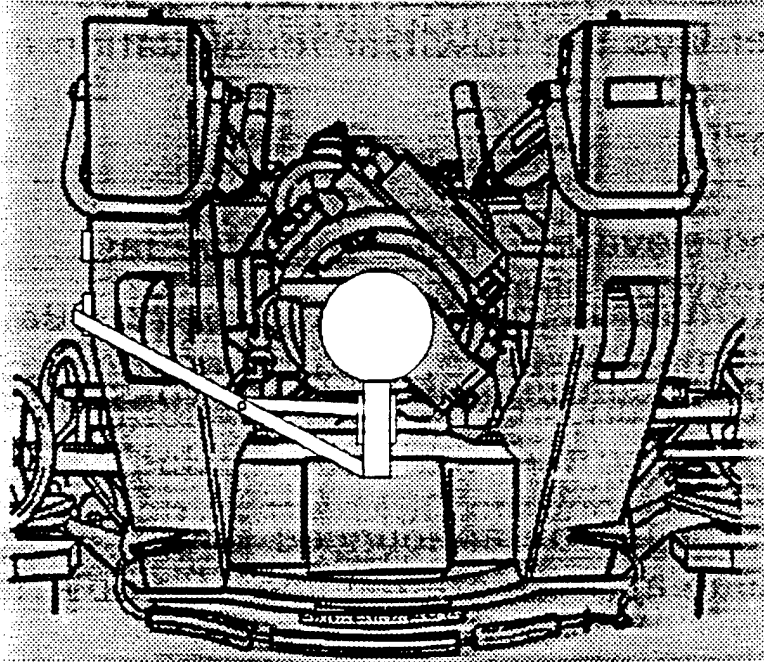

ILLUSTRATION NOT TO SCALE

FIG. 17. PRIME MOVER MOUNTED WITH MODIFIED ARM II MODULE

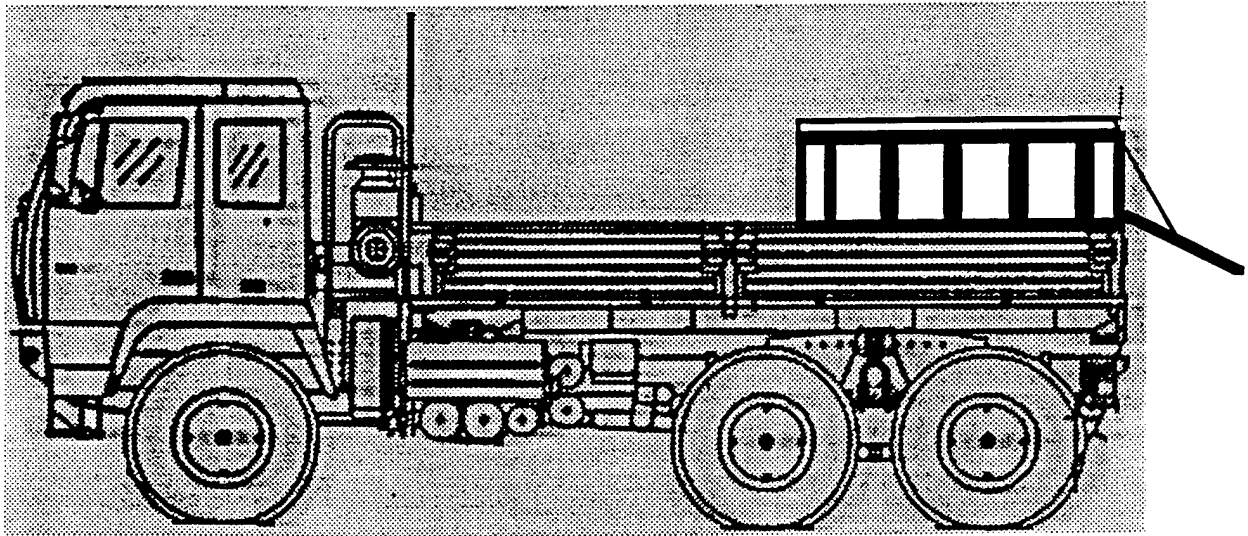

ILLUSTRATION NOT TO SCALE

ANNEX B

ACRONYMS

AD	Air Drop
APU	Auxiliary Power Unit
ARTRAIL	Artillery Ammunition Trailer
ASP	Ammunition Supply Point
ATCAS	Advanced Towed Cannon System
ATP	Ammunition Transfer Point
BSA	Brigade Support Area
CSS	Combat Service Support
COSCOM	Corps Support Command
DSA	Division Support Area
FA	Field Artillery
FAASV	Field Artillery Ammunition Support Vehicle
FAPP	Field Artillery Projectile Pallet
FMTV	Family of Medium Tactical Vehicles
HEMTT	Heavy Expanded Mobility Tactical Truck
LAPES	Low Altitude Parachute Extraction System
LPRS	Loose Projectile Restraint System
LRP	Logistics Resupply Point
LVAD	Low Velocity Air Drop
LVS	Logistic Vehicle Supply
MHE	Material Handling Equipment
MMC	Material Management Center
MSR	Main Supply Route
MTV	Medium Tactical Vehicle
PLS	Palletized Load System
PM-AMMOLOG	Project Manager-Ammunition Logistics
RAM	Reliability, Availability, Maintainability
UBL-UE	Unit Basic Load-Upload Equipment