

REPORT DOCUMENTATION PAGE

Form Approved
OMB No. 0704-0188

Public reporting burden for this collection of information is estimated to average 1 hour per response, including the time for reviewing instructions, searching existing data sources, gathering and maintaining the data needed, and completing and reviewing the collection of information. Send comments regarding this burden estimate or any other aspect of this collection of information, including suggestions for reducing this burden, to Washington Headquarters Services, Directorate for Information Operations and Reports, 1215 Jefferson Davis Highway, Suite 1204, Arlington, VA 22202-4302, and to the Office of Management and Budget, Paperwork Reduction Project (0704-0188), Washington, DC 20503.

1. AGENCY USE ONLY (Leave blank)		2. REPORT DATE 30 March 1995	3. REPORT TYPE AND DATES COVERED S3IR Ph I Final 94.08.01 - 95.01.31	
4. TITLE AND SUBTITLE A Small Autonomous Aircraft for Remote Sensing of the Atmosphere			5. FUNDING NUMBERS PROC INSTRUMENT F49620-94-C-0044 3005/SS	
6. AUTHOR(S) Tad McGeer			8. PERFORMING ORGANIZATION REPORT NUMBER AFOSR-TR-95-0270	
7. PERFORMING ORGANIZATION NAME(S) AND ADDRESS(ES) The Insitu Group MP11.48R Cook Underwood Road Underwood, Washington 98651				
9. SPONSORING/MONITORING AGENCY NAME(S) AND ADDRESS(ES) Air Force Office of Scientific Research 110 Duncan Avenue Suite B115 Bolling AFB DC 20332-0001			10. SPONSORING/MONITORING AGENCY REPORT NUMBER F49620-94-C-0044	
11. SUPPLEMENTARY NOTES *Original contains color plates; All DTIC reproductions will be in black and white.				
12a. DISTRIBUTION/AVAILABILITY STATEMENT Unlimited <div style="border: 1px solid black; padding: 5px; width: fit-content; margin: 10px auto;">This document has been approved for public release and sale; its distribution is unlimited.</div>			13. DISTRIBUTION CODE <div style="border: 2px solid black; padding: 10px; text-align: center; width: fit-content; margin: 10px auto;">DTIC SELECTED JUN 19 1995 F</div>	
13. ABSTRACT (Maximum 200 words) <p style="text-align: center;">In 1992, The Insitu Group began development of a very small, very long-range autonomous aircraft (or <i>aerosonde</i>) for economical meteorological reconnaissance in remote and oceanic regions of the globe. Prototype work was done over the first two years of the program, and in the last half of 1994 the focus moved to development of an aircraft suitable for field trials. All of the necessary components were produced during the Phase I period, including airframe, avionics, powerplant, ground equipment, and software. We are now proceeding toward integrated flight tests, and initial deployment in a meteorological field experiment late in 1995.</p> <p style="text-align: right; margin-top: 20px;">DTIC QUALITY INSPECTED 8</p>				
14. SUBJECT TERMS Autonomous aircraft, Meteorological instrumentation, Radiosonde, Aerosonde			15. NUMBER OF PAGES 41	
17. SECURITY CLASSIFICATION OF REPORT Unclassified			16. PRICE CODE	
			20. LIMITATION OF ABSTRACT SAR	
18. SECURITY CLASSIFICATION OF THIS PAGE Unclassified	19. SECURITY CLASSIFICATION OF ABSTRACT Unclassified			

DISCLAIMER NOTICE

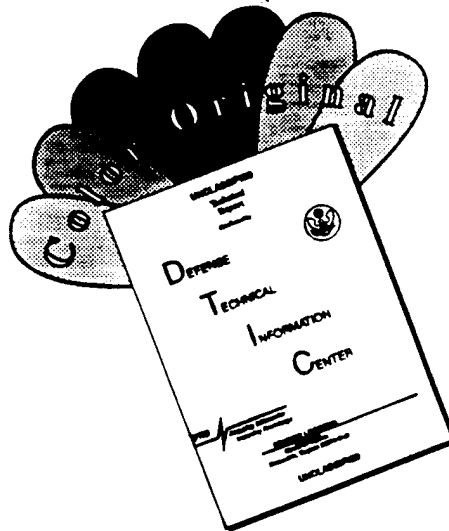

THIS DOCUMENT IS BEST QUALITY AVAILABLE. THE COPY FURNISHED TO DTIC CONTAINED A SIGNIFICANT NUMBER OF COLOR PAGES WHICH DO NOT REPRODUCE LEGIBLY ON BLACK AND WHITE MICROFICHE.

A Small Autonomous Aircraft for Remote Sensing of the Atmosphere

Final Technical Report
under Phase I SBIR 94NL119
(ending 31 January 1995)
sponsored by the
Air Force Office of Scientific Research
Bolling AFB, DC



INSITU

The Insitu Group
MP11.48R Cook Underwood Road
Underwood, Washington USA 98651
Principal Investigator: Tad McGeer

30 March 1995

Accession For		
NTIS CRA&I		<input checked="" type="checkbox"/>
DTIC TAB		<input type="checkbox"/>
Unannounced		<input type="checkbox"/>
Justification		
By		
Distribution /		
Availability Codes		
Dist	Avail and/or Special	
A-1		

Abstract

In 1992, The Insitu Group began development of a very small, very long-range autonomous aircraft (or *aerosonde*) for economical meteorological reconnaissance in remote and oceanic regions of the globe. Prototype work was done over the first two years of the program, and in the last half of 1994 the focus moved to development of an aircraft suitable for field trials. All of the necessary components were produced during the Phase I period, including airframe, avionics, powerplant, ground equipment, and software. We are now proceeding toward integrated flight tests, and initial deployment in a meteorological field experiment late in 1995.

Contents

1	The aerosonde program	3
1.1	Review of objectives	3
1.1.1	Engine performance	6
1.1.2	Flight control and guidance software	6
1.1.3	Aerosonde systems	6
1.1.4	Operations without undercarriage	7
1.1.5	Design and flight demonstration of a new aerosonde	7

19950615 061

2	Powerplant	9
2.1	Engine modifications	9
2.2	Engine performance	10
2.3	Electrical power	14
2.4	Operating protocol	17
3	Avionics	20
3.1	Line-of-sight modem	20
4	Software	20
5	Hardware-in-loop simulation	24
6	Outlook	24
7	Staff	26

Abbreviations

AFOSR	US Air Force Office of Scientific Research
BMRC	Bureau of Meteorology Research Centre
DoE	Department of Energy
EMF	electromotive force
ESCAP	United Nations Economic and Social Commission for Asia and the Pacific
FAA	Federal Aviation Administration
GPS	Global Positioning System
KB	kilobyte
MCTEX	Maritime Continent Thunderstorm Experiment
ONR	Office of Naval Research
PWM	pulse-width modulated
R/C	radio control
RF	radio frequency
SBIR	Small Business Innovation and Research Program
SFC	specific fuel consumption
TCAS	Transponder-based Collision Avoidance System
WMO	World Meteorological Organization

1 The aerosonde program

Since 1992 The Insitu Group has been developing a very small autonomous aircraft, or *aerosonde*, for economical meteorological reconnaissance over oceans and remote areas. The program follows from the recent appearance of lightweight avionics components – particularly GPS and satellite communications equipment – which make it possible to design long-range, long-endurance autonomous aircraft of unprecedentedly small size. Thus an aerosonde will be capable of about 7000 km range, and about 4 days endurance, but have a gross weight less than 15 kg (table 1). Such small size brings multiple economic benefits, including low costs of manufacture and use; easy shipment; assembly and operation by a single person; opportunistic basing; and independence of elaborate facilities. Total operating costs consequently will amount to only a few tens of dollars per flight-hour. This level is sufficiently low to allow wide-scale sounding operations by the world's meteorological services, especially in oceanic "data voids" where *in situ* data are chronically sparse. Indeed these operations should become economical as never before, as should a variety of other environmental-monitoring applications which can be performed with lightweight instrumentation.

Realisation of this potential requires several years of development, moving from prototype work to an expanding series of field trials, and transitioning gradually to routine service. In 1994 AFOSR became a sponsor of this program, adding its support to contributions from the Marine Meteorology Program of the Office of Naval Research, and from the Australian Bureau of Meteorology. Here we report progress over the six-month period covered by AFOSR's Phase I SBIR contract, ending in January 1995. During this period we moved from prototypes to development of an initial operational version of the aircraft, in preparation for field trials scheduled to begin in November 1995. These are planned as part of the Maritime Continent Thunderstorm Experiment (MCTEX) off the northern coast of Australia.

The prototypes, three of which were built in 1992-93, demonstrated in preliminary form most of the components needed for long-range autonomous operations: airframe, powerplant, avionics, and software. The move to an operational version called for a comprehensive design iteration in all of these areas, with a target specification as listed in table 1. For the six-month period our specific objectives were as follows [13]:

1. Mapping of engine performance, including fuel and oil consumption across the full power range
2. Qualification of flight-control and guidance software for airspeeds between 15 m/s and 35 m/s
3. Qualification for long-endurance flight of:
 - (a) powerplant and installation
 - (b) fuel system
 - (c) avionics
 - (d) ground station and software
4. Demonstration of routine operations without undercarriage
5. Design and flight demonstration of a new aerosonde as specified in table 1

1.1 Review of objectives

Each of these objectives was achieved, although we are still working toward an integrated demonstration of all systems in flight. A summary of results follows; details are discussed in later sections.

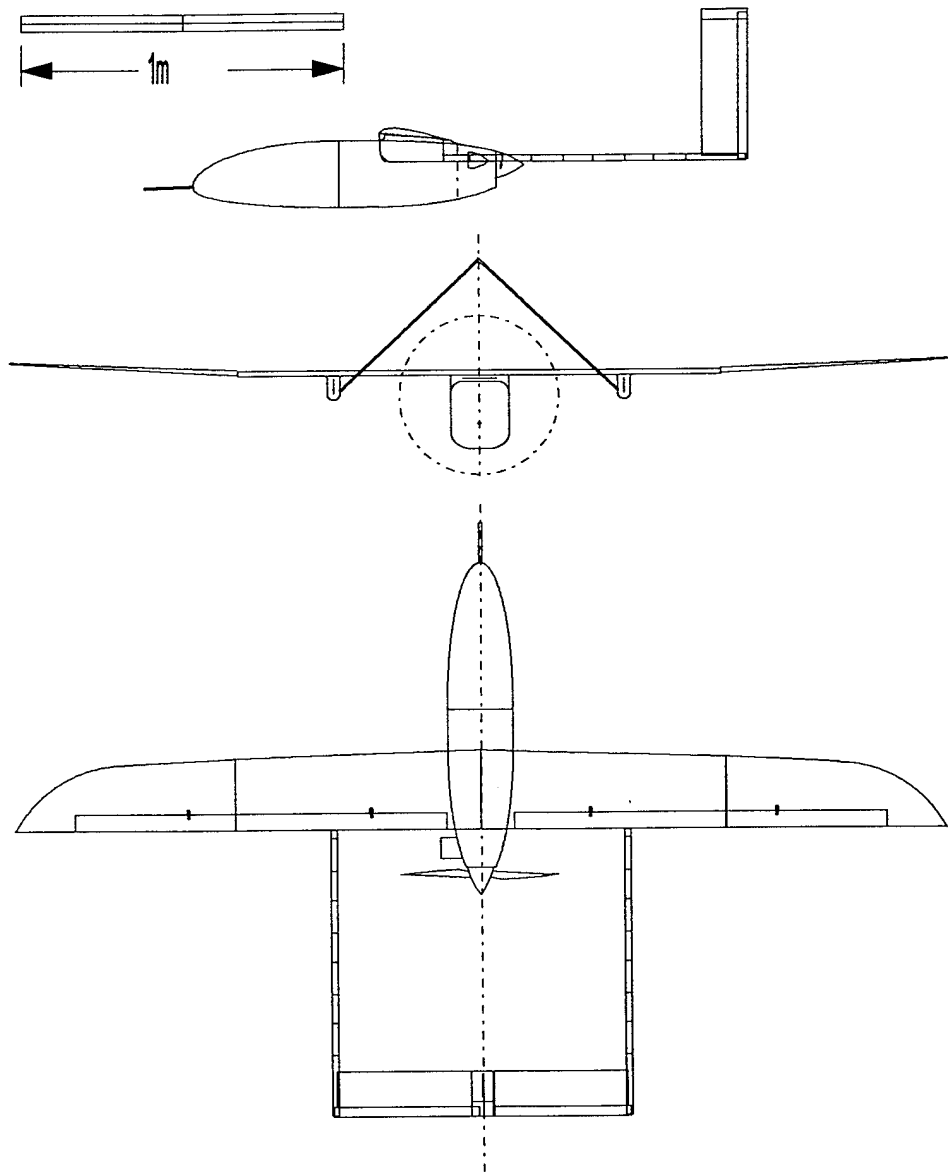

Figure 1: Aerosonde general arrangement

Table 1: Projected Aerosonde specifications. The version currently under development meets the Phase I specification, and uprated models will follow over several years of development.

	Phase I	~ 1998
wing span [m]	2.9	3.0
wing area [sq m]	0.55	0.55
propellor diameter [m]	0.6	0.85
weights [kg]		
avionics	5.0	2.6
powerplant	1.5	3.2
airframe	3.3	2.5
gasoline	4.1	5.4
oil	0.1	0.3
gross	14	14
performance		
propellor efficiency	0.7	0.8
engine rating	700 W @ 5500 rpm	800 W @ 5500 rpm
specific fuel consumption [gm/kWh]	450	370
optimum L/D @ SL	18.5 @ 21 m/s	20 @ 20 m/s
maximum speed	38 m/s @ SL	57 m/s @ 16 km
range to zero fuel @ econ. cruise [km]	3500	7300
range to zero fuel @ max. speed [km]	2200	5500
SL climb rate [m/s]	2.9	3.4
service ceiling [km]	5	16
time to ceiling at gross weight [hr]	0.8	1.3
climb/descent cycle time [hr]	1.9	4
endurance in climb/descent cycle [days]	1.8	2.8
endurance at SL [days]	2.1	4

1.1.1 Engine performance

The engine developed for prototype aircraft was further modified during the six-month SBIR period, and performance was extensively mapped on a bench dynamometer. Fuel consumption has proved to be considerably better than the target value, and oil consumption is satisfactory.

1.1.2 Flight control and guidance software

Avionics were comprehensively redesigned for the operational aerosonde version, and most of the six-month period was devoted to (1) adapting prototype software to the new hardware, and (2) developing a hardware-in-loop simulator for testing aircraft systems on the ground. The main elements of adaptation and testing were complete by the end of January, and flight-control software was requalified in simulation over the full airspeed, weight, and centre-of-gravity envelope. Flight tests are planned for April. Software is written in *C*, and the onboard executable size is 124KB.

1.1.3 Aerosonde systems

1. Powerplant and installation

Substantial work was done on carburetion to achieve reliable operation at near-stoichiometric fuel/air ratio. This work encompassed both carburettor hardware and mixture-control software. Results are satisfactory for flight testing and initial field trials, but, at the same time, we can see significant room for improvement later in the program.

Mechanical reliability appears to be satisfactory, although only after a series of connecting-rod failures prompted redesign of lubrication arrangements. Our prototype "total-loss" (*i.e.* single pass) oiling with gravity feed was replaced by a circulating system that pumps oil through the crankcase. We have accumulated about 50 hours of each of two engines, one running exclusively on the bench dynamometer, and the other both on the dyno and in flight. The record is encouraging, but we continue to build engine time and to look for problems.

Under the powerplant heading we include the onboard generator as well as the engine. Several electrical-system iterations were required over the Phase I period and beyond, encompassing the generator, drive, and power-regulation circuitry. Flight hardware was completed only at the end of March.

2. Fuel system

The specific concern in fuel system design has been to exclude the possibility of air bubbles regardless of aircraft attitude and fuel level. (Even a small bubble can stop the engine, and at present the aircraft has no provision for in-flight restart.) A simple bladder has proven effective, although care must be taken to ensure that the bladder and plumbing are purged of air prior to flight.

3. Avionics

During the Phase I period the prototype avionics were completely redesigned. New components were added, the flight computer, GPS, and communications system were changed, circuitry was revised, and packaging was very substantially improved. The first new avionics set was completed in January. Since then it has performed well in hardware-in-loop simulation, and flight testing is imminent. Table 3 lists the main components, and figure 8 shows the layout in block-diagram form.

4. Ground station and software

The new avionics set required a new ground-station architecture as shown in figure 9. It

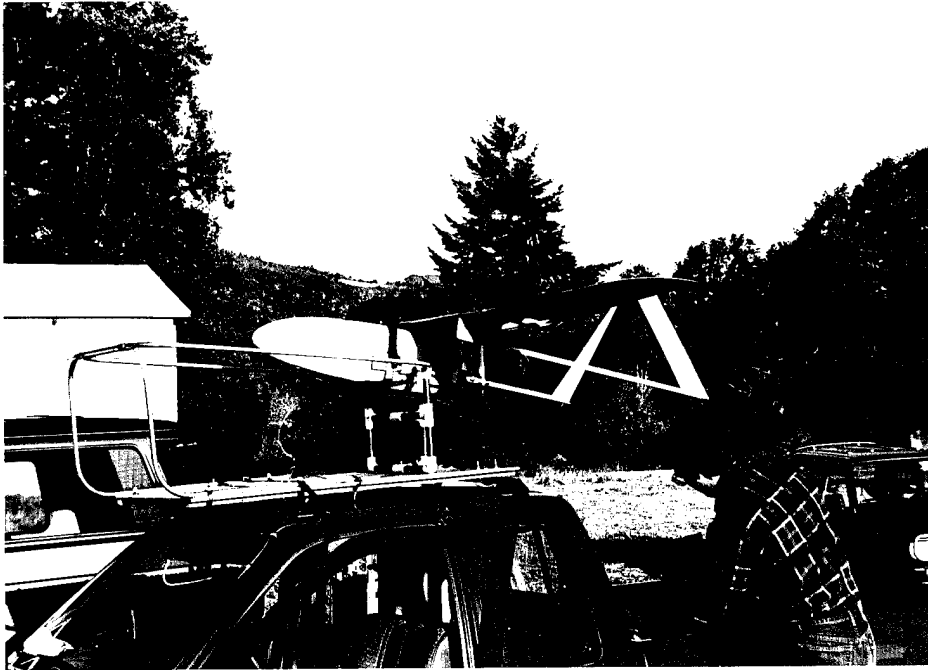

Figure 2: The second aerosonde prototype in its cartop launcher. The cradle is hinged at left. At flying speed the aircraft lifts off the roof, pulling a ripcord as it goes; this allows the cradle to spring open, and the aircraft flies free.

includes a PC for supervisory control, and a pilot's manual control console, each of which communicates with the aircraft through a new "switchboard" computer. The latter is a stripped-down version of the onboard avionics set. New software was developed for this module (totalling 69KB executable), and ground-PC software from the prototype was extensively modified (614KB executable). The hardware and most of the software work were complete at the end of the Phase I period, but software modifications and enhancements are ongoing. Coding is in *C*.

1.1.4 Operations without undercarriage

Prototype aerosondes were fitted with landing gear, but operation without undercarriage has now become routine. The aircraft is launched from a cartop cradle (figure 2) at about 20 m/s. It lands on the belly, with a run of several tens of metres on dry grass.

1.1.5 Design and flight demonstration of a new aerosonde

Structural design of the new aerosonde version has been much improved over the three prototype aircraft, and airframe weight has come out slightly below the target specification. Three new airframes were in hand at the end of the January, with structural features as listed in table 2.

Table 2: Aerosonde airframe evolution

aircraft #	fuselage	wgt [gm]	wing	wgt [gm]	pylons and booms	wgt [gm]	tail	wgt [gm]	total [gm]
1 & 2	plywood box with fiberglass aeroshell	3270	fibreglass/rohacell sandwich skin; graphite/balsa/fibreglass spar	1330	plywood pylons; aluminum booms	400	three-piece balsa core with fibreglass skin	250	5250
3	fibreglass/divinacell shell; fibreglass/plywood bulkheads and floors; bladder fuel tank	1900	graphite/rohacell/fibreglass sandwich skin; graphite/balsa/fibreglass spar; improved planform and airfoil	1300	plywood pylons; aluminum booms	400	three-piece balsa core with fibreglass skin	250	4260
4	graphite/hexcell/kevlar shell; kevlar/hexcell bulkheads; bladder fuel tank	1300	graphite/rohacell/fibreglass sandwich skin; graphite/balsa/fibreglass spar	1150	fibreglass pylons; graphite booms	339	three-piece fibreglass/rohacell sandwich shell	255	3300
5	graphite/aeromat/fibreglass shell; aeromat/fibreglass bulkheads; bladder fuel tank	1205	graphite/rohacell/fibreglass sandwich skin; graphite/balsa/fibreglass spar	1170	fibreglass pylons; graphite booms	339	three-piece fibreglass/rohacell sandwich shell	255	3170

various minor items are included in the total airframe weight a/c 1-3 are prototypes; 4 and 5 are "pre-production" versions of the initial operational aerosonde. #5 is in process at the time of writing.

Flight tests began in January to evaluate handling, engine behaviour, and fuel-system reliability. These were flown with a hobbyist-type radio-control system, pending completion of avionics and software work. To date only a few minor problems have been found. We are now preparing for tests with full avionics, and for demonstration of long-endurance capability.

2 Powerplant

The powerplant is a major development item in most new aircraft programs, and the aerosonde program is no exception. In our case special engineering is necessary because of the combination of small scale and the premium placed on reliability and fuel consumption. For other small engines (*e.g.* in model aircraft and garden tools) these are not such high priorities, and their fuel consumption in particular is generally very poor – *e.g.* order 1000 gm/kWh or worse for a two-stroke “weed-wacker”, *vs.* less than 300 gm/kWh for a typical car. Hence although we take a model-aircraft engine as our starting point, modification is necessary to achieve satisfactory performance.

2.1 Engine modifications

The aerosonde engine is a 20 cc, single-cylinder four-stroke made by Enya (Yokohama). We were drawn to engines of this class because they are favoured for modification in “Mileage Marathon” competitions for lightweight land vehicles, and hence have demonstrated potential for high efficiency. Our own modifications are as follows:

1. Conversion to gasoline

The engine is designed for compression ignition with “glow fuel” (nitro-methanol). Simplicity makes this the system of choice for model aircraft, but it is unacceptable for us because it leads to very high fuel consumption. (Glow fuel has less than half the energy of gasoline per unit mass). Hence we convert to spark ignition (from CH Electronics, Riverton, Wyoming) and run on 100LL aviation gasoline. We modify the exhaust camshaft to trigger a hall-effect ignition switch once per engine cycle.

2. Carburettor

The switch to gasoline dramatically lowers fuel flow, and consequently requires a new carburettor. By a fortunate coincidence, Walbro (Cass City, Michigan) has just introduced, for an entirely different purpose, a carburettor which meets our needs. It is the product of pending California emissions standards for small utility engines, which have generated (at last) some interest in efficiency and hence in four-stroke design. Ryobi (Phoenix) has been the first to respond, with a 26 cc “weed-wacker” four-stroke; it is for this engine that Walbro’s carburettor (WT-332) was designed. Although the Ryobi engine is bigger (and, incidentally, heavier) than the Enya, the carburettor can be adapted without much difficulty.

3. Mixture control

We replace the carburettor’s low- and high-speed needle valves to improve sensitivity, and fit a servo and linkage so that adjustment can be done by the flight computer. At present mixture is scheduled open-loop as a function of throttle position. This is acceptable for flight operations planned over the next year, but we intend eventually to implement a closed-loop scheme with feedback of exhaust O₂, exhaust-gas temperature, or engine speed.

4. Fuel pump

Fuel delivery and pressure regulation in the Walbro carburettor is via an integral diaphragm pump driven by crankcase pressure. We install a crankcase port for the pump just below the cylinder barrel.

5. Lubrication

The Enya engine is designed to have oil introduced with fuel, but this method of lubrication is rather profligate and hence not attractive for our application. Instead we fit a separate oil circuit. It is a wet-sump ("splash") scheme, with oil introduced to the crankcase via new ports fore and aft of the front crankshaft bearing, and drained from a third port at the back of the engine. Crankcase vacuum draws oil through check valves to the inlet ports, and a vibration-driven pump circulates it back to a reservoir in the aerosonde's mid-bay.

6. Compression ratio

Our first engine was modified to increase compression ratio from the standard 8.0 to 10.1. Relative to the unmodified engine this produced a smaller performance improvement than was expected on thermodynamic grounds (*cf.* figures 4, 5), and additional modifications are necessary (*i.e.* in valving) to realise the engine's full potential. Work in this direction will proceed during 1995.

7. Reverse rotation

The aerosonde uses an off-the-shelf model propellor which is right-handed. The Enya must be reversed from its normal rotation in order to use a right-handed propellor in the aerosonde's direct-drive pusher layout. This is quite easy to do since the Enya has separate intake and exhaust camshafts; in fact this feature led us to choose the Enya over other model-aircraft four-strokes.

2.2 Engine performance

Our modifications have been developed through an ongoing program of design iteration and testing on a bench dynamometer (figure 3). The dyno is instrumented for engine speed, mean torque, fuel consumption, manifold vacuum, and ambient-, cylinder-head, and exhaust-gas temperature. A PC is used for data acquisition, analysis, and engine control. A propellor is used as the load.

Dynamometer data for our two test engines are shown in figures 4 and 5. Both engines have fuel consumptions of about 300 gm/kWh at full power, which is quite substantially better than the figure of 450 gm/kWh in our published specification (table 1). Hence there is some prospect of exceeding our targets for range and endurance. However the fuel consumption is higher (in power-specific terms) at part throttle; consequently minimum fuel consumption can be realised in practice only if the engine is run in a burst-off cycle. While this would be acceptable (even advantageous) for many data-gathering missions, it would also require provision for in-flight restart; we will not add that feature until later in the program. Hence at present we can only idle the engine as an alternative to in-flight shutdown. We discuss the consequences for range and endurance in §2.4.

A further constraint is that mixture control with the current carburettor and control strategy is somewhat erratic, and to be safe we consequently have to fly with somewhat higher fuel flow rates than can be maintained on the dynamometer (figure 5). Much of the problem is due to uneven fuel vaporisation, which can be improved by raising the intake-air temperature; consequently we are now working on an exhaust heat-muff. Closed-loop mixture control will also be an important addition.

We have recently proposed a program of engine improvements to DoE [11]. The program includes carburetion refinement, closed-loop control, higher compression, revised valving, and geared propellor drive. We can look forward to this effort delivering better performance in due course, but what we have in hand is quite adequate for field trials planned in 1995.

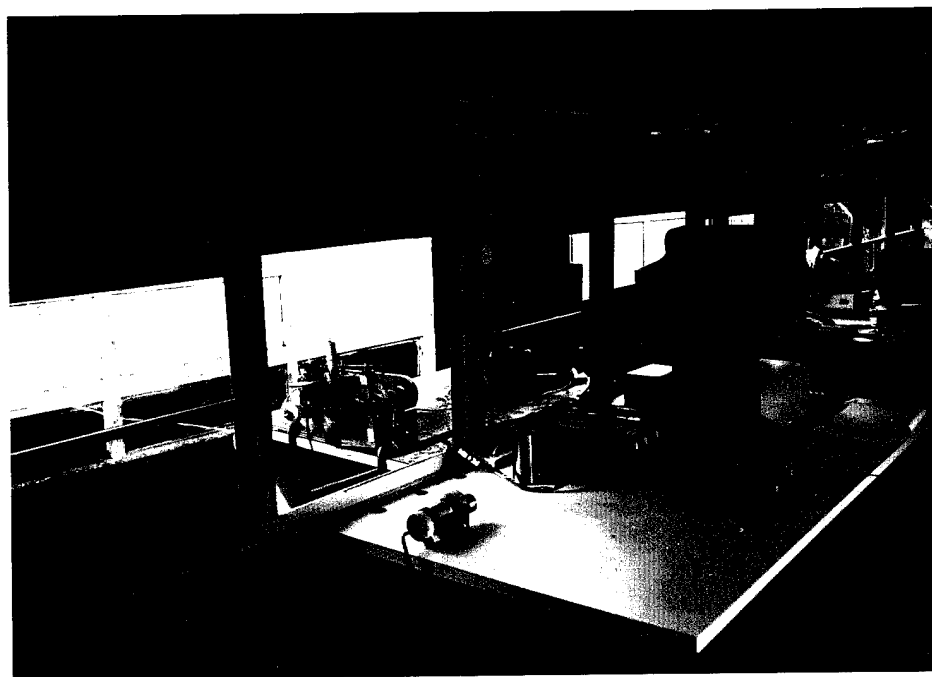

Figure 3: Gasoline-fuelled Enya R120 running on the bench dynamometer. The dynamometer measures torque, speed, fuel consumption, and temperatures, which are acquired by the PC at right. This view is from the front of Insitu's schoolbus, which has been fitted as a mobile workshop.

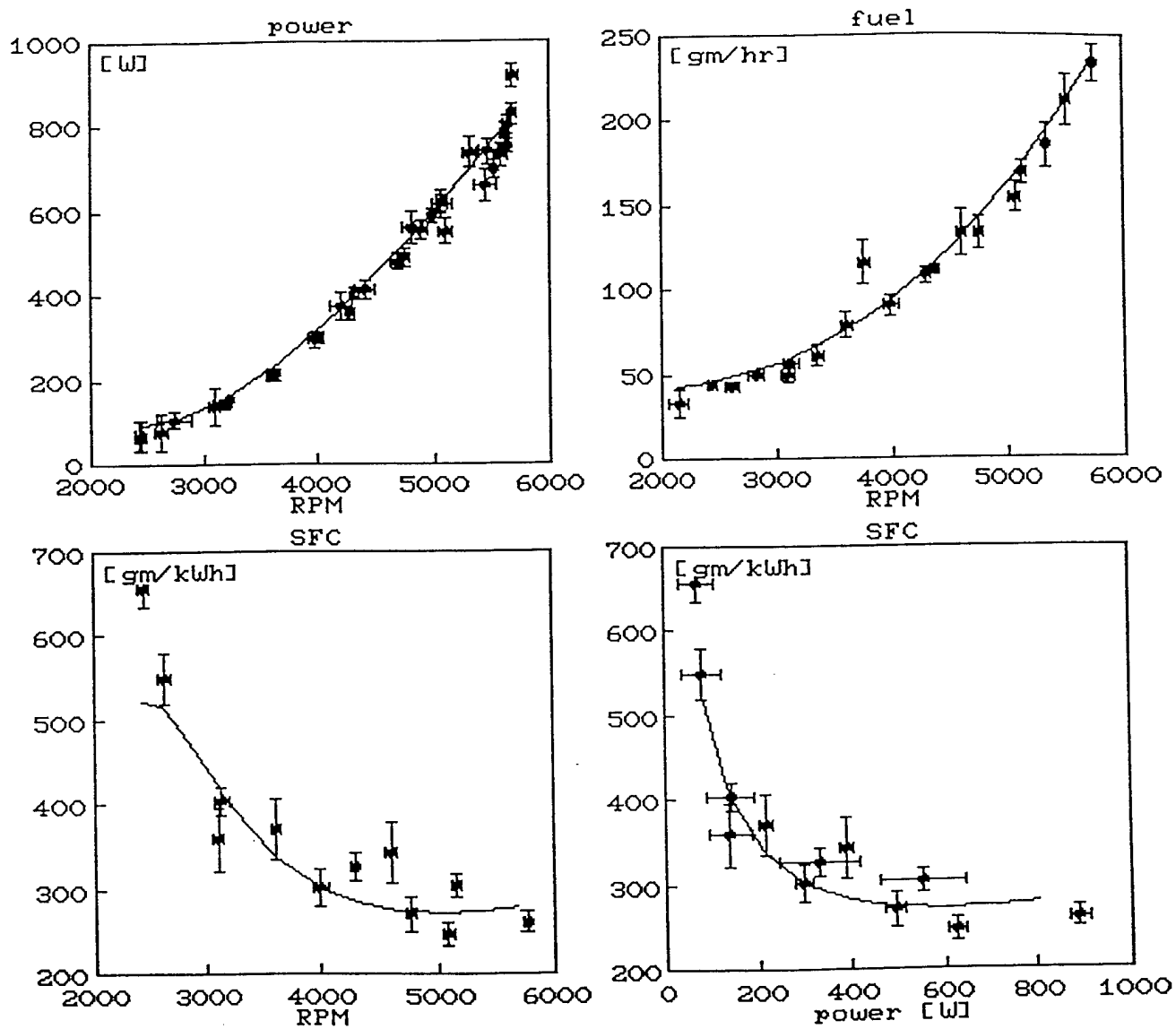

Figure 4: Performance of Insitu's modified Enya R120 #1, as measured with an APC 20-10 propeller on the bench dynamometer. The upper plots show power and fuel mass flow; lower plots show power-specific fuel consumption. Spark advance is 23°.

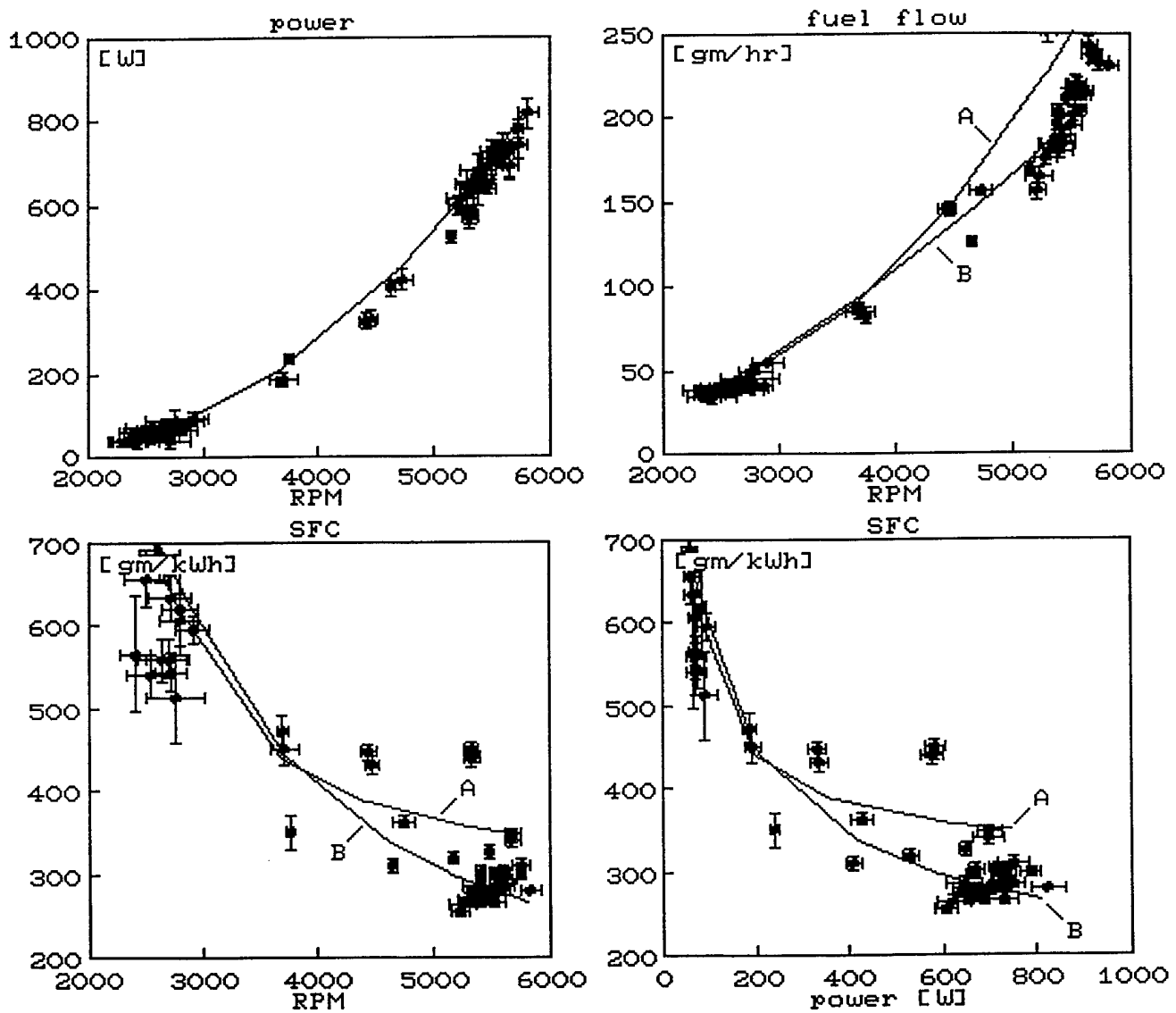

Figure 5: Performance of Insitu's modified Enya R120 #2, with an APC 20-8 propellor as is currently used in flight. (Engine #2 has compression ratio 8.0, vs. 10.1 on engine #1; also for this test the spark was advanced to 36° .) Curves A were measured with mixture settings considered reliable for current flight operations. Curves B were measured with the mixture leaned for minimum specific fuel consumption.

2.3 Electrical power

The aerosonde's average electrical load over a long-duration flight will average between 10 and 20 W. The aircraft has an engine-driven generator for the base requirement, and a battery with about 15 minutes capacity for transients.¹ The electrical load takes a big bite out of aircraft range, as we can demonstrate with a variation on the classical Breguet range equation. Define

c	specific fuel consumption
D	aircraft drag
P_E	engine shaft power
P_{ge}	electrical power output by the generator
P_{gm}	shaft power input to the generator
R	range
V	airspeed
W	aircraft weight
W_{to}	weight at take-off
W_e	weight at landing
η_G	generator drive efficiency
η_p	propellor efficiency
η_e	range reduction due to electrical generation

Then the power required of the engine is

$$\begin{aligned} P_E &= \frac{DV}{\eta_p} + P_{ge} \frac{P_{gm}}{P_{ge}} \frac{1}{\eta_G} \\ &= \frac{V}{\eta_p} \frac{W}{L/D} + P_{ge} \frac{P_{gm}}{P_{ge}} \frac{1}{\eta_G} \end{aligned} \quad (1)$$

Fuel consumption is

$$\frac{dW}{dt} = -gcP_E \quad (2)$$

Combining these and rearranging gives

$$\frac{\eta_p}{gc} \frac{L}{D} \frac{dW}{W} = - \left(1 + \frac{L}{D} \frac{P_{ge}}{WV} \frac{P_{gm}}{P_{ge}} \frac{\eta_p}{\eta_G} \right) dR \quad (3)$$

Integrating, and putting the result in the standard range-equation form, leaves

$$R = \frac{\eta_p \eta_e}{gc} \frac{L}{D} \ln \frac{W_{to}}{W_e} \quad (4)$$

where

$$\frac{1}{\eta_e} = 1 + \left\langle \frac{L}{D} \frac{P_{ge}}{WV} \frac{P_{gm}}{P_{ge}} \frac{\eta_p}{\eta_G} \right\rangle \quad (5)$$

" $\langle \rangle$ " indicates an appropriate average over the flight. We needn't worry about the details of averaging, since our point can be made with rough numbers. For the current aerosonde design (*cf.*

¹We are occasionally asked about batteries or solar as alternatives, but each is a non-starter. A battery with capacity for 3 days at 20 W would weigh more than an aerosonde. Solar is excluded because an aerosonde must operate at night and under overcast.

Table 1)

$$\begin{aligned}
 L/D &\approx 18 \\
 P_{ge} &\approx 20 \text{ W} \\
 \langle W \rangle &\approx 100 \text{ N} \\
 \langle V \rangle &\approx 20 \text{ m/s} \\
 P_{gm}/P_{ge} &\approx 1.7 \\
 \eta_p &\approx 0.7 \\
 \eta_G &\approx 0.9
 \end{aligned}$$

Then

$$\eta_e \approx 0.81$$

Thus we have a "direct" range penalty of about 20% due to a 20 W electrical load. Adding the "indirect" effect due to displacement of fuel by the weight of generator, drive, and battery makes the overall penalty about 1.5% per watt, which is sufficiently large to make the electrical system the focus of considerable engineering effort. One basic and ongoing priority is to minimise the electrical requirement, but design of the generator and drive train is equally important.

We have tested a number of DC motors, both brushed and brushless, for use as generators. The best has proved to be a relatively inexpensive model-car motor (Epic 5.0), and its performance map is plotted in figure 6. We use it with modifications as follows:

1. Brushless operation

The standard motor has a brushed armature, which is both a failure point and a significant contributor to friction. We remove the brushes and connect to the armature directly. The engine spins the motor housing (via a 2.2:1 belt drive) while the armature is held stationary. This generates 3-phase AC, which is rectified by the aerosonde's power system.

2. Rewinding

Switching regulators in the power system require input between 14 V and 30 V. To match this requirement we have to rewind the armature, increasing the motor constant threefold to 3.5 V/Krpm.

3. Regulation circuitry

The allowable range of input voltage for the switching regulators is about 2:1, whereas the generator output range is more than 3:1 over all possible in-flight loads and engine speeds. To cope with this we wind the armature in an electrical "Y". At low armature voltage the 3-phase rectification is done between pairs of "Y" arms, while at high voltage it is done between each arm and the centre tap. (Unfortunately this entails an efficiency penalty relative to figure 6, since ohmic losses are increased at high speed.)

These arrangements have produced an adequate solution, but certainly not an optimal one. We have explored various other options, including some exotica: an exhaust-driven generator, or a thermoelectric pile generating power from the engine's waste heat. (The latter is technically attractive but prohibitively expensive; we estimated more than \$1000 per aircraft.) Perhaps the best alternative is a "pancake" generator mounted directly on the crankshaft, with radial windings and a stationary axial field (as opposed to axial windings and a spinning radial field in the current generator). Keeping the field stationary would substantially reduce magnetic-hysteresis losses, which cause much of the drop in efficiency at high speed in figure 6.

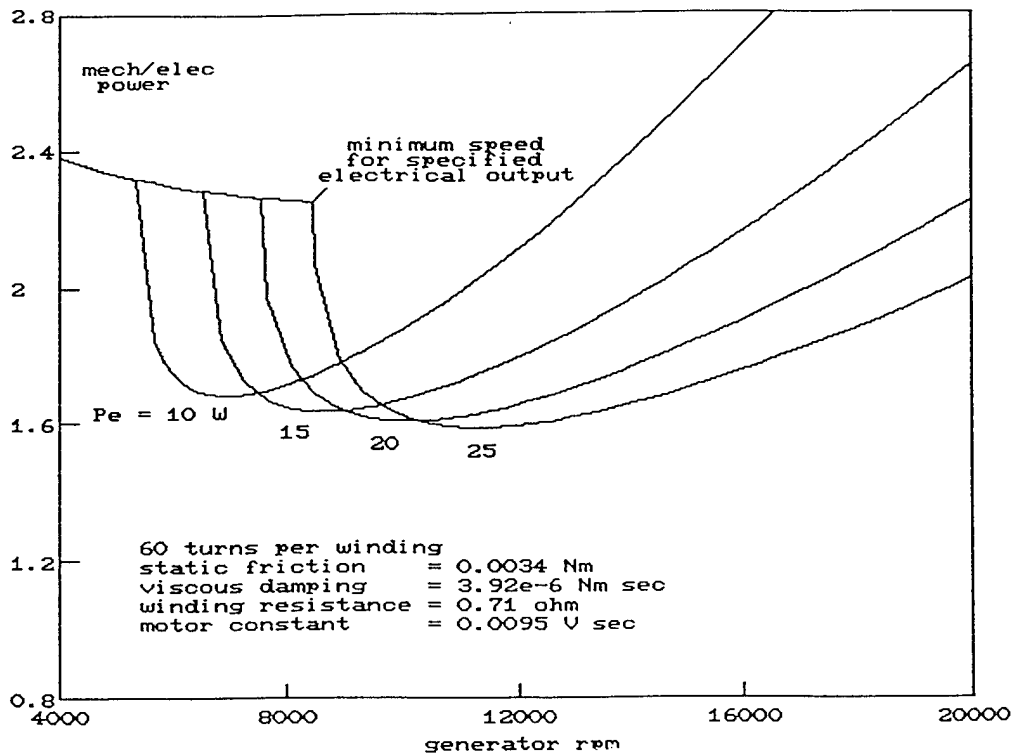

Figure 6: Mechanical power absorbed by an Epic 5.0 DC generator as a function of speed and electrical output. For any specified power level there is a well-defined optimum speed. At lower speeds the EMF drops, so current must rise to maintain the specified electrical output, and ohmic (i^2R) losses rise steeply. At higher speeds “viscous” losses rise, somewhat more gradually, primarily because of eddy currents in the motor’s magnetic circuit. The higher the output power, the higher the optimum speed.

2.4 Operating protocol

We mentioned earlier that the aerosonde engine delivers minimum fuel consumption only when operated near peak power (figure 5). In this respect it is no different from larger aircraft engines, which suffer pumping losses when throttled. However it does differ from the norm in that its peak power is a relatively large multiple of cruise power – about threefold larger, rather than the more typical value of about 1.5. (Roughly speaking this is because the engine must be sized for climb, which means that peak power is dictated by gross weight; meanwhile cruise power is dictated by drag, and the aerosonde, being designed with emphasis on aerodynamic efficiency, has a relatively low drag-to-weight ratio.) Steady cruising consequently would entail closing the throttle and running at high SFC. But one can avoid this problem by running in bursts, and so alternating between climb and descent. Issues then arise with respect to operating protocol and electrical generation. Figure 7 illustrates the options.

Case *A* is the (unattainable) best case, with no generator load and the engine *shut down* for descent. (A variable-pitch propellor could spin the engine for restart.) In that case the effective SFC is just the SFC during climb, which is minimised by climbing at peak power. This produces a cycle in which the engine is running for about a quarter of the time (more when the aircraft is at gross weight, and less when fuel is burned off).

Case *B* is a second calculation done with zero generator load. However it shows the *first-order* consequence of adding a generator to the engine – namely, that the engine cannot be shut down for descent. Instead one is forced to idle to keep the generator running, and this exacts a substantial range penalty. Idling furthermore reduces the advantage to be gained from a short-duty-cycle climb, since a faster and more efficient climb is balanced against more fuel wastage during descent.

Cases *C* and *D* include the generator load. In case *D* we calculate the load using figure 6 and a 4:1 gear-up from the engine to the generator, with the gearing efficiency presumed to be 0.9. In case *C* we specify that the generator runs always at the optimum speed for a 20 W load. (We have done preliminary design of a two-speed automatic transmission for this purpose, although considering the additional complexity its merits are open to debate.)

The difference between cases *B* and *C* is about 20%, as we calculated in the rough range analysis (5). However this comes on top of the larger $A \rightarrow B$ penalty due to idling. The idling penalty might be eliminated by driving the generator with a separate windmill, and we have shown an estimate for this option as case *E*. The efficiency of this drive is poor since it involves, in effect, power transmission via two propellers in series; furthermore we must add to the transmission loss the drag of a generator pod and mount. Yet accepting all of that for the sake of an engine-off descent is an option well worth considering. Our rough estimate suggests a 20% range improvement by using a windmill instead of an engine drive, but we must do more idling and windmill-efficiency analysis before we can draw a definitive conclusion.

Two additional possibilities come readily to mind: the first is to run on batteries during descent, and recharge during climb; the second is to use the windmill only during descent, and switch to an engine drive for climb. Unfortunately each of these options offers benefits which accrue with increasing time spent in climb, but it is only by a short climb cycle that one can realise minimum SFC. Hence (although some calculations are in order) the battery option is probably a non-starter. The windmill-and-engine-drive option (suggested in [6]) might be worthwhile if the transmission can be made sufficiently light and efficient, but not to the extent of producing a really substantial improvement over case *E*.

In any case our main interest at present is less with optimisation than with simplicity and fast development. Consequently we are planning burst/idle operation with a single-ratio generator drive – *i.e.* case *D*. While this approach is cast by figure 7 as the worst option, it is still good enough for flight testing. It is also good enough for MCTEX field trials. However after analysis of

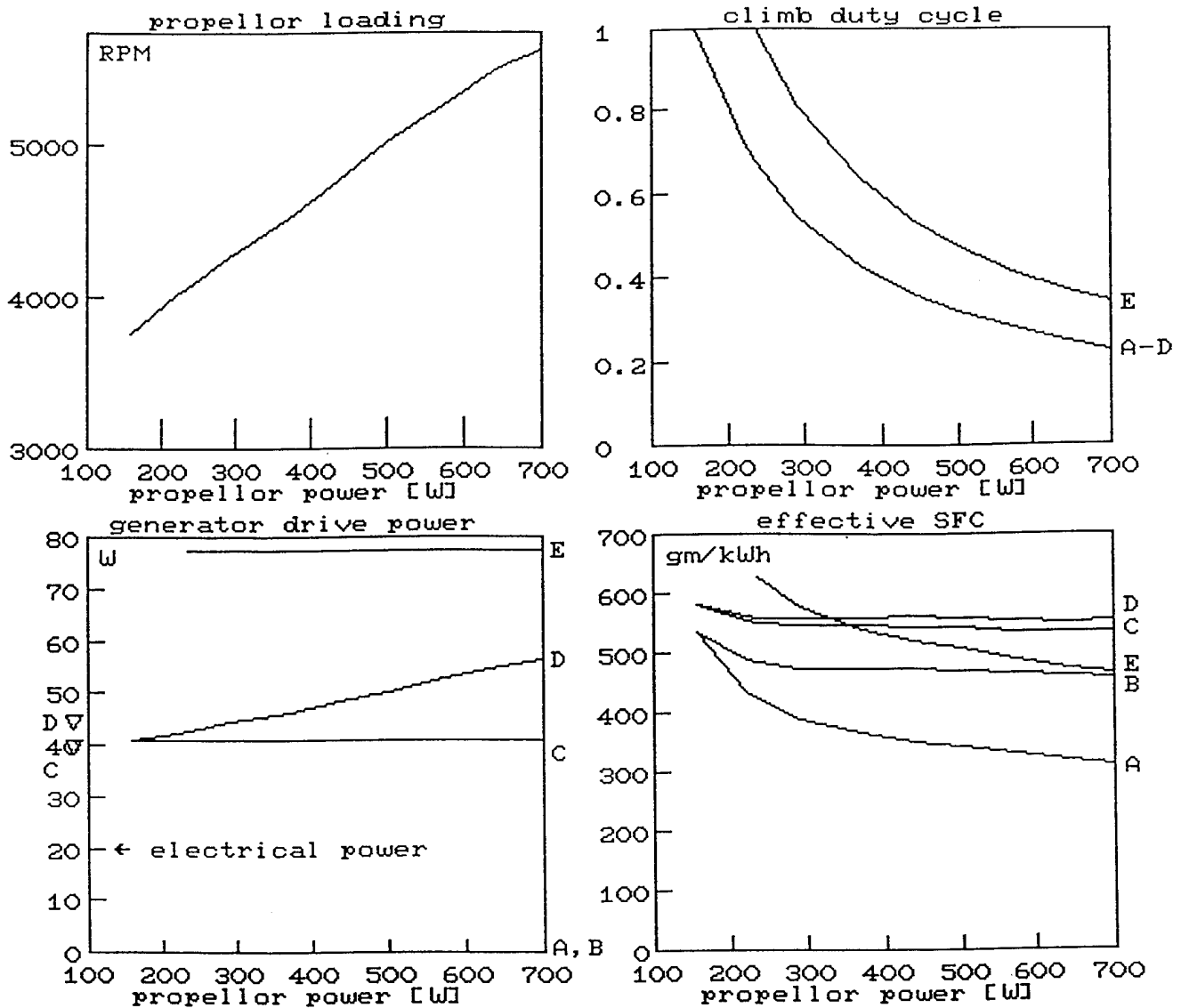

Figure 7: Estimates of effective specific fuel consumption c/η_e with various climb/descent operating protocols. Mean flight power is taken to be 158 W (100 N gross weight; 18.5 L/D ; 20 m/s airspeed; and 70% propeller efficiency) and propeller loads are calculated for an APC 20-10. Fuel flow is estimated from static tests on Insitu's dynamometer. (A) engine off for descent; zero electrical power. (B) engine idling for descent (30 gm/hr fuel flow with zero propeller thrust); zero electrical power. (C) idling descent; generator always driven at optimum speed. (D) idling descent; 4:1 gear-up from engine to generator. (E) engine off for descent; generator driven by a windmill. Triangles show generator loads at idle.

Table 3: Components of 1994-96 and follow-on aerosonde avionics sets

item	1994-96				follow-on			
	supplier	model	weight [gm]	power [W]	supplier	model	weight [gm]	power [W]
onboard computer	Onset	Tattletale 8	56	0.40	Onset	Tattletale 8	56	0.40
analog interface and connectors	Insitu		56	1.00	Insitu		56	1.00
digital interface/power supply	Insitu		140	4.99	Insitu		140	3.36
long-range data link, incl antenna	Trimble	Galaxy	2500	12.00	TBD	LEO COMSAT	250	2.00
short-range data link, incl antenna	Loral	CRI-400-TRLS	260	9.60	Loral	CRI-400-TRLS	260	9.60
GPS navigator/patch antenna	Trimble	SV6-CM/FOG	92	1.35	Trimble	SV6-CM/FOG	92	1.35
echo altimeter	BMRC	FM/CW radar	100	0.50	BMRC	FM/CW radar	100	0.50
static pressure sensor	Sensym	SCX15	10	0.02	Sensym	SCX15	10	0.02
pitot pressure sensor	Sensym	SCXL004	10	0.02	Sensym	SCXL004	10	0.02
yaw rate gyro	Murata	G-09-A	45	0.18	Murata	G-09-A	45	0.18
heading sensor	KVH	C100	64	0.48	TBD	differential GPS	200	1.00
avionics temperature sensor	AD	AD290	1	0.01	AD	AD290	1	0.01
ambient temperature sensor	AD	AD290	1	0.01	AD	AD290	1	0.01
cylinder-head temperature sensor		K thermocouple	5			K thermocouple	5	
exhaust-gas temperature sensor		K thermocouple	10			K thermocouple	10	
intake manifold pressure sensor					Sensym	SCX30	2	0.02
exhaust manifold pressure sensor					Sensym	TBD	20	0.02
hydrostatic fuel level sensor	Lucas	NPH-8-002.5DH	7	0.02	Lucas	NPH-8-002.5DH	7	0.02
2 x radiosonde sensors	AIR	radiosonde sets	250	0.50	TBD		250	0.5
engine ignition and tachometer	Pro-Spark	R/C model type	110	2.00	Pro-Spark	R/C model type	110	2
packaging, mounting and wiring			400				200	
servoes	JR	8 x NES-3321	280	1.60	JR	9 x NES-3321	315	1.80
other actuators						TBD	150	2
acquisition lights (4 on wing)			50	2.00				
TOTAL AVIONICS			4446	27			2289	16
generator incl mount and drive	Epic	5.0 (mod)	210		Epic	5.0 (mod)	210	
13.2V, 1200mAh NiCad pack	Sanyo	11x KR1200AUL	300		Sanyo	11x KR1200AUL	300	
OVERALL TOTAL			4956	27			2799	16

flight data, as well as further design and testing of the windmill/shutdown option, we may switch to that approach later in the program.

3 Avionics

Figure 8 is a block diagram of the avionics set that was designed and built during the Phase I period. Table 3 gives the corresponding list of major components, including weights and power requirements. (It also includes a tentative list for a follow-on set which should be available in 1996-97). Details are given in the *Avionics Specification* [7].

The avionics are built around a 68332-based computer made by Onset (Pocasset, Massachusetts). We build custom circuitry for power supply and interfacing to digital and analog devices, which are shown around the periphery of figure 8.

In the upper left of the figure we have 24 analog inputs from various "engineering" sensors, of which we use 13 at present and have reservations for another 6. Proceeding clockwise round the diagram, we show asynchronous serial interfaces in the upper right. The 68332 has one on-chip UART which we dedicate to debugging, and we add an off-chip UART (Philips 26C198) with 8 more bidirectional serial ports (plus 32 bit-addressable I/O pins). Of these UART ports we currently use two, one for the line-of-sight radio, and one for the GPS. Two more may be used for dual thermodynamics-sensor packages, although this interface has not yet been decided. Another is reserved for a satellite-messaging terminal, which we plan to add for long-range field trials in 1996 (funds permitting). This will still leave room for expansion, *e.g.* with a second computer.

Proceeding further around figure 8 we have shown a few bit-toggled devices; of these only the acquisition lights will be fitted immediately.

The bottom of the diagram shows peripherals interfaced via the 68332 Time Processor Unit, which is an on-chip multimode processor for generating and measuring time-varying waveforms. All of the flight controls are operated through this interface. The actuators are standard model-aircraft servoes and are commanded by pulse-width modulation. The TPU also controls the engine ignition through a deadman's switch. The switch must be refreshed continually to keep the engine running; thus it will stop the engine in the event of hardware or software failure.

3.1 Line-of-sight modem

CRI-400 series radios made by Loral Conic (San Diego) are used in both the avionics and ground station. These offer 9600 baud with up to 5W RF power in the 400 MHz band. We calculate the RF output to be sufficient to meet our requirement of 100 km line-of-sight range for 1995 field trials. Frequency can be changed on the fly over a 6 MHz band, so that we can implement a protocol for channel hopping in the event of interference (attachment 3). The aircraft has a dipole antenna inside one of tailplanes (which is built as a fibreglass shell).

These radios are a major departure from the prototype system, in which we used low-power spread-spectrum modems made for a wireless ethernet. The key difference is that the new radios are *half-duplex*. This has led to a great deal of work on protocols to handle both normal communications (attachment 2) and failure recovery (attachment 3).

4 Software

When we began design of the "operational" version of the aerosonde, we had already developed quite a substantial body of software for the prototype aircraft. This included independent autopilots for airspeed, altitude, turn rate, and mixture control; an outer loop for great-circle course

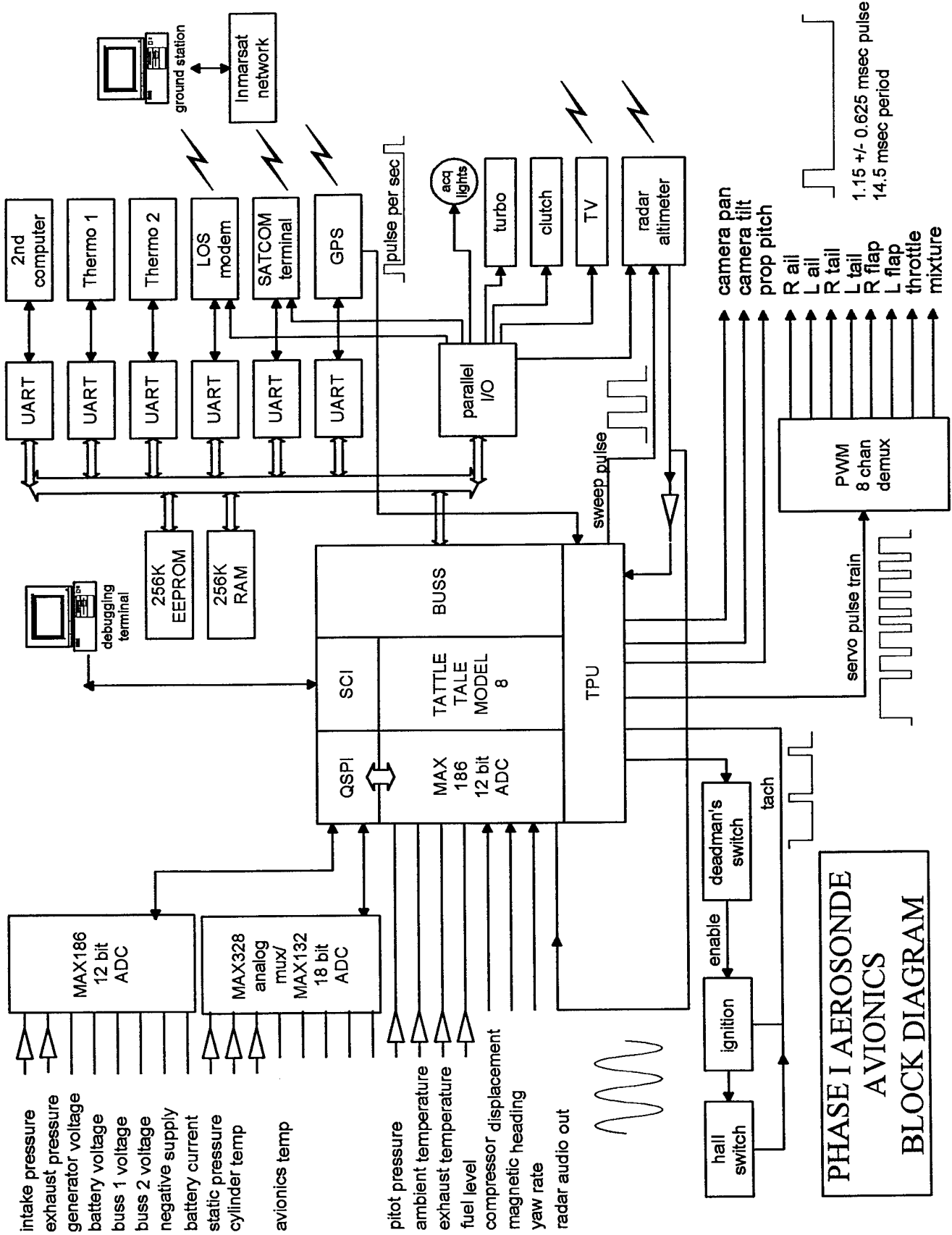

PHASE I AEROSONDE AVIONICS BLOCK DIAGRAM

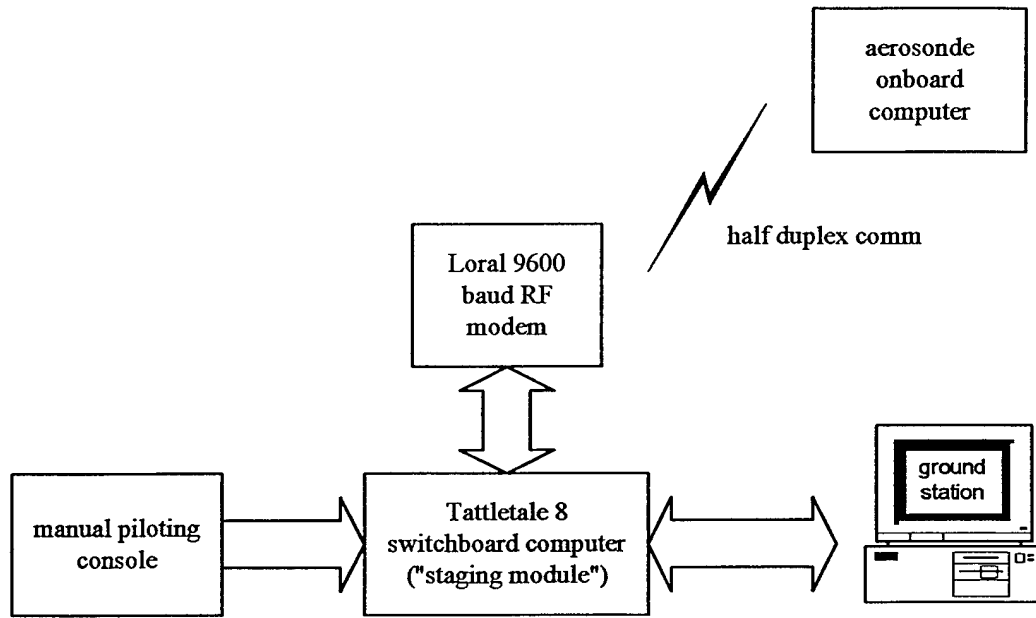

Figure 9: Ground control architecture. For take-off and landing the aerosonde is controlled manually from the pilot's console, which is essentially the same as those used for model aircraft. Autopilot loops are enabled once the aircraft is clear of local obstacles. The ground station controls autopilot modes and monitors aircraft status. Telemetry is routed through a "switchboard" computer, which is a stripped-down version of the computer used onboard. It manages a half-duplex communications protocol with the aircraft. Aircraft control is maintained in the event of failure of either the pilot's console or the PC (or indeed of the whole ground station, in which case the aircraft continues to execute its flight plan autonomously).

tracking; and provision for direct or stability-augmented manual control of any selected aircraft axes. Details of the autopilot design are given by McGeer [9] and the various modes are described in attachment 1. Continuous full-duplex communication was maintained with the ground station, which provided tabular and graphical data display, anomaly alerting, autopilot mode control, flight-plan editing, downlink logging, and replay.

In moving to the new aircraft there was no need for more functionality, but nevertheless a great deal of new software has been required. There have been four main areas of work:

1. "Low-level" functions for the new hardware (particularly for the Philips UART, which is a new and relatively complex chip);
2. Half-duplex communications protocols (attachments 2, 3);
3. Implementation of a new ground architecture (figure 9) whereby communications are routed through a "switchboard" computer;
4. Hardware-in-loop simulation.

The last two of these items are consequences of a basic change in flight-control paths. Manual control for the prototype was exercised via a hobbyist-type radio controller (R/C) independent of the ground PC and data link. The design was such that in the event of failure of the flight computer, control would revert to the manual channel. This arrangement allowed us to compromise somewhat on elaborate pre-flight avionics qualification, since we could tolerate in-flight failures. (And on one occasion we did in fact have an in-flight failure, due to an intermittent power connector.) However in practice the R/C system proved to be a weak link, and R/C failure led to loss of the third prototype aerosonde (and our only avionics set) in April 1994. Our first Phase I progress report [13] reviewed this failure in detail.

In the new avionics the R/C system (which was always regarded as a short-term expedient) is eliminated, but as a consequence we are completely reliant upon the flight computer and its software. We are also completely reliant upon a single communications link for control from the ground. Very thorough testing by hardware-in-loop simulation has therefore become mandatory, as has a robust ground architecture. Prior to first flight we want to have high confidence that

1. software bugs have been eliminated from flight and ground computers;
2. flight and "switchboard" computers will reset safely in the event of software exceptions or "crash" bugs;
3. hardware weaknesses have been exposed and corrected;
4. in the event of failure of either the manual- or supervisory-control branches in the ground system, the other branch will continue to function (attachment 1);
5. in the event of communications failure, the aircraft will maintain safe autonomous operation (attachment 1);
6. in the event of onboard hardware or uncorrected software failure, the aircraft will come down in a limited area (by activating the deadman's ignition switch).

This effort has continued beyond the Phase I period, and is expected to be sufficiently complete for a first flight with avionics in April.

5 Hardware-in-loop simulation

Development of the aerosonde simulator was begun in summer 1994. By January it was fully functional, including complete (*i.e.* nonlinear) rigid-body dynamics, first-order engine dynamics, and a nonlinear aerodynamic model (which is accurate for small angles, and at least adequate for large angles). It also includes fuel-slosh dynamics for a large integral tank originally intended for the mid-fuselage bay; however the slosh issue has been substantially eliminated by going to a bladder tank, so this model is not used. The full set of models and calculation procedures is specified by McGeer [5]. Executable is 841KB.

The simulator has three operating modes, as follows:

1. Software checkout

The simulator includes key parts of the flight-control code, and much of the supervisory code from the ground-station PC. These can be coupled with the dynamics integration, and the software thus exercised independent of hardware.

2. Hardware-in-loop

In hardware-in-loop simulation, the flight computer operates just as in flight. It drives a set of servoes; their positions are read continuously by the simulator; the dynamics model is integrated in real time; and signals simulating the primary control sensors are returned to the flight computer. These include the pitot pressure sensor, static pressure sensor, yaw rate gyro, ambient temperature sensor, tachometer-pulse generator, and GPS.

3. Engine-in-loop

Instead of calculating an engine model, the simulator can measure the speed of the real engine running on the aircraft. It can then use this measurement (plus the positions of the aileron, elevator, rudder, and flap servoes) as input to the flight dynamics simulation, and again returns synthetic sensor signals to the onboard computer. This mode allows practically complete realism in exercising all ground and onboard systems, as well as the crew.

The simulator is the ultimate tool for verifying the conditions for first flight enumerated in §4. Check-out in software mode was done in January, and testing in the two hardware modes is proceeding toward our April flight target.

6 Outlook

For a technical point of view we consider the aerosonde program to be in good order. We have identified all of the necessary elements; we have good quantitative knowledge of their performance, and corresponding confidence in the aircraft specification; and we have a clear idea of what has to be done to get aerosondes into the field. Work on the new version of the aircraft has taken longer than expected, and kept our small group very hard-pressed. However this effort has produced a good system, and we are moving systematically toward first flight. With the resources currently in hand we will continue to be hard-pressed to be ready for MCTEX field trials in November, but we think that our chances are reasonable.

When we extend our outlook to the long term we can be very confident indeed. The need for *in situ* information is evident; the system to use it is primed and waiting; its value is well known. The aerosonde is distinctive, and perhaps even unique, in its promise to deliver such information, in volume, at a cost that is not only economically justifiable but also fiscally practicable. There is some risk, but the probability of success is high, and the rewards of success would be great. Hence we expect that the aerosonde will attract support for vigorous development, and that its potential will be well established before the end of the decade.

References

- [1] *Memorandum of Agreement between The Insitu Group and Federal Aviation Administration*. FAA Northwest Mountain Region (ANM-534), Seattle, June 1994.
- [2] Greg J. Holland, Tad McGeer, and Harold Youngren. Autonomous Aerosondes for economical atmospheric soundings anywhere on the globe. *Bulletin of the American Meteorological Society*, 73(12):1987-1998, December 1992.
- [3] Tad McGeer. *Aerosonde Flight Planning and Simulation for Tropical Cyclone Reconnaissance*. Technical Report, The Insitu Group, MP11.48R Cook Underwood Road, Underwood, Washington, USA 98651, January 1993. 9 pp.
- [4] Tad McGeer. *Aerosonde Hazard Estimation*. Technical Report, The Insitu Group, MP11.48R Cook Underwood Road, Underwood, Washington, USA 98651, June 1994. 7 pp.
- [5] Tad McGeer. *Aerosonde Simulator Specification*. Technical Report, The Insitu Group, MP11.48R Cook Underwood Road, Underwood, Washington, USA 98651, July 1994. 33 pp.
- [6] Tad McGeer. *Autonomous Aerosondes for Meteorological Measurements in Remote Areas*. Technical Report, Aurora Flight Sciences, Alexandria, Virginia, USA, June 1991. 29 pp.
- [7] Tad McGeer. *Avionics Specification for the Phase 1 Aerosonde*. Technical Report, The Insitu Group, MP11.48R Cook Underwood Road, Underwood, Washington, USA 98651, June 1994. 48 pp.
- [8] Tad McGeer. Economical reconnaissance of tropical cyclones by small autonomous aircraft. In *Proceedings of the ICSU/WMO Symposium on Tropical Cyclone Disasters*, pages 79-91, Peking University Press, Beijing, October 1992.
- [9] Tad McGeer. *Flight Control Specification for the Phase 1 Aerosonde*. Technical Report, The Insitu Group, MP11.48R Cook Underwood Road, Underwood, Washington, USA 98651, April 1992. 53 pp.
- [10] Tad McGeer. Meteorological instrumentation for the aerosonde autonomous sounding aircraft. July 1994. Phase I SBIR Proposal US DoD N94-130, 22 pp.
- [11] Tad McGeer. Powerplat optimisation for very small, very long-range autonomous aircraft. February 1995. Phase I SBIR Proposal US DoE 95-12d, 23 pp.
- [12] Tad McGeer. *Procedures for Aerosonde Flight Operations*. Technical Report, The Insitu Group, MP11.48R Cook Underwood Road, Underwood, Washington, USA 98651, June 1994. 20 pp.
- [13] Tad McGeer. *A Small Autonomous Aircraft for Remote Sensing of the Atmosphere*. Technical Report, The Insitu Group, MP11.48R Cook Underwood Road, Underwood, Washington, USA 98651, August-September 1994. Progress report 1 under Phase I SBIR 94NL119, 30 pp.
- [14] Tad McGeer. A small autonomous aircraft for remote sensing of the atmosphere. January 1994. Phase I SBIR Proposal US DoD AF94-009, 22 pp.
- [15] Tad McGeer. Very small autonomous aircraft for economical long-range deployment of lightweight payloads. In *Proceedings of the First International Airborne Remote Sensing Conference*, pages 329-339, Strasbourg, September 1994.
- [16] Tad McGeer and Greg J Holland. The aerosonde project: status, plans, and prospects for economical soundings over the oceans. In *Proceedings of the International Conference on Weather Analysis and Forecasting in the Asia-Pacific Monsoon Region*, Taipei, June 1994.
- [17] Tad McGeer and Greg J Holland. Aerosonde status, plans, and prospects for economical wide-scale soundings over the oceans. In *Proceedings of the Ninth Symposium on Meteorological Observations and Instrumentation*, American Meteorological Society, Charlotte, North Carolina, March 1995.
- [18] Tad McGeer and Greg J. Holland. Small autonomous aircraft for economical oceanographic applications on a wide scale. *Oceanography*, 6(3):129-135, 1993.

7 Staff

The Insitu Group has a staff of four devoted to aerosonde development, as follows:

1. **Tad McGeer (PhD Aeronautics and Astronautics, Stanford 1984)** is president of The Insitu Group, and has been concentrating on aerosonde development since first proposing the concept in 1991. This followed advanced design work on the *Perseus* series of autonomous aircraft in 1990-91, while serving as Chief Scientist of Aurora Flight Sciences (Manassas, Virginia). Before 1990 he was on the Engineering Science faculty at Simon Fraser University in British Columbia, where his work included legged robots and autonomous submersibles.
2. **Ross Hoag (BSEE, Montana State 1989)** is Insitu's lead electronics engineer, with prime responsibility for avionics development. He is thoroughly experienced in electronic systems from specification to test and demonstration, with particular emphasis on high-speed design and packaging for reliability and light weight. Mr Hoag has come to the project from work on instrument landing systems with Advanced Navigation (Hood River, Oregon) and programs at Tektronix on electronic test equipment.
3. **Kurt Ziegler (BSEE, Kansas State 1984)** is Insitu's lead software engineer. He also came to the project from ILS work at Advanced Navigation, where he was involved with flight test as well as electronics and software development. His experience includes several years as Principal Engineer on TCAS development with Honeywell.
4. **Clifford Jackson** is Insitu's pilot and airframe/powerplant technician. He is a top-ranked competitor in model aerobatics, and has been involved with model aircraft and the supporting industry for 25 years. His knowledge of modelling techniques is vital in making economical and proven engineering choices in many areas of aerosonde design.

We also draw upon the expertise of Hood Technology Corporation (Hood River, Oregon), a small firm founded in 1992 by Dr Andy von Flotow. Drs McGeer and von Flotow have been colleagues since doctoral work at Stanford in the early 1980s. Dr von Flotow was Associate Professor of Aeronautics and Astronautics at MIT for several years, where his research encompassed dynamics and control of spacecraft and electromechanical systems. Since moving to Oregon his group specialises in designing, building, and testing prototype products for active control of sound and vibration.

The Australian Bureau of Meteorology has also been closely involved in the aerosonde program since its inception. Its work includes meteorological instrumentation, applications planning, and very active promotion of the concept. BoM activities are directed by Greg Holland (PhD Atmospheric Science, Colorado State 1983) as leader of the Mesoscale Meteorology Research Group.

Attachments

1. *Aerosonde autopilot modes and mode switching*
2. *Aerosonde half-duplex communications protocols*
3. *Aerosonde communications failure and recovery*

AEROSONDE AUTOPILOT MODES AND MODE SWITCHING

Tad McGeer
The Insitu Group
30 March 1995

REVIEW OF FLIGHT CONTROL MODES

The aerosonde currently has five autopilot loops as follows:

1. dynamic pressure (*i.e.* indicated airspeed), controlled by elevator
2. yaw rate, controlled by aileron and rudder
3. static pressure (*i.e.* barometric altitude) or pressure rate (*i.e.* vertical speed), controlled by throttle
4. engine rpm, controlled by throttle (note that 3 and 4 cannot operate simultaneously)
5. GPS course tracking, running as an outer loop issuing commands to the yaw rate loop

Consider the airspeed loop as an example to explain modes of operation. If the loop is disabled, then elevator position is controlled manually from the pilot's console. If it is enabled, then either the keyboard or the pilot's console can be selected as the source of the airspeed command. From the keyboard, the desired true airspeed is simply typed into the appropriate I/O table; if the specified value is considered safe, then the command is sent to the aircraft. From the console, the pilot's "pitch" input commands airspeed rather than elevator position. Moving the stick forward makes the aircraft step to higher speed. The effect is to give the pilot "stability-augmented" control (SA). This is also available on the "roll" input (commanding turn rate) and the "power" input (commanding climb rate). (Scaling of the pilot's commands, and the airspeed corresponding to neutral pitch input, can be changed from the keyboard.)

The accompanying diagram illustrates the various sources for elevator commands, followed by similar diagrams for rudder/aileron, throttle, mixture, and flap.

The power to select among these various combinations is, of necessity, shared among the flight computer and the two ground computers. The sharing of powers is specified below.

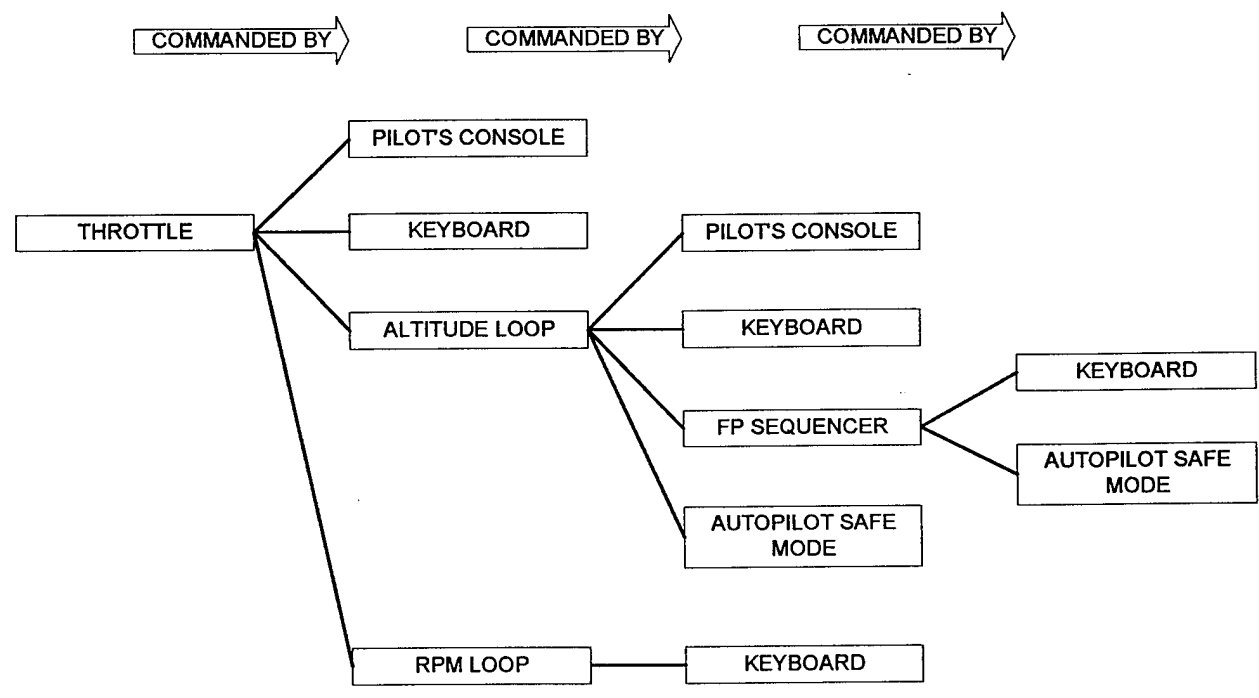
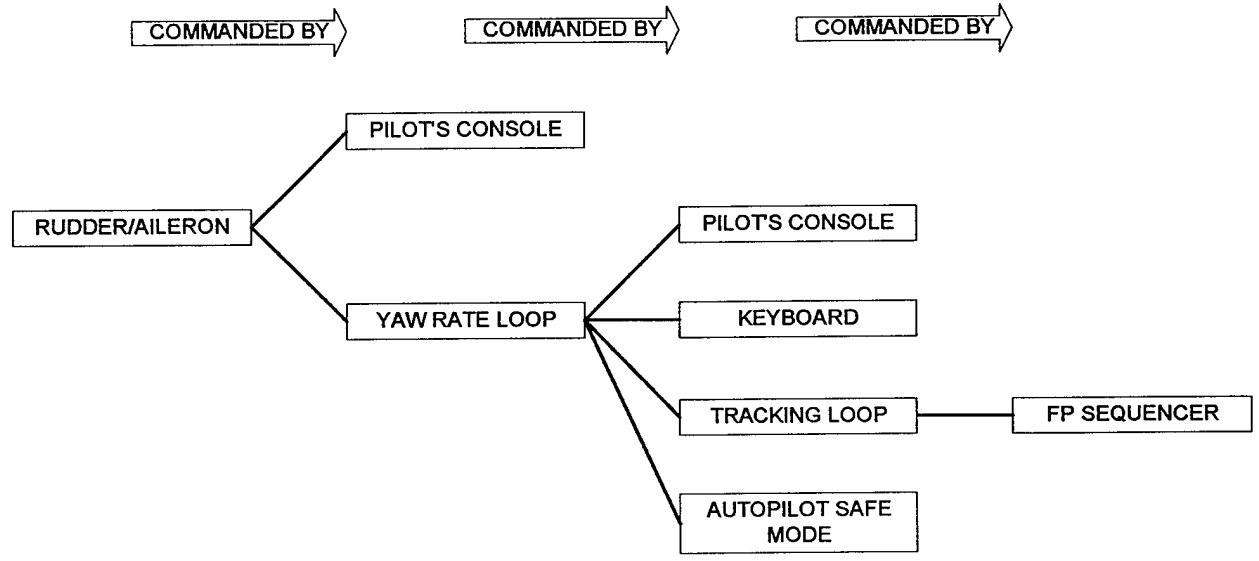
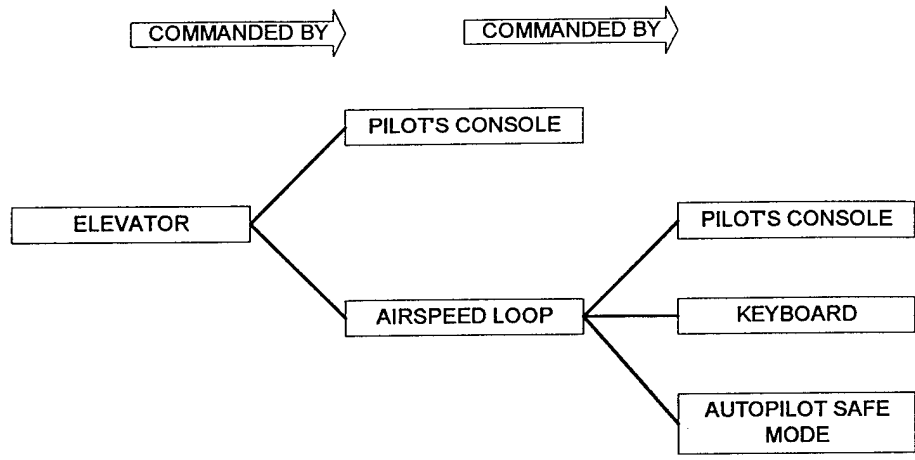

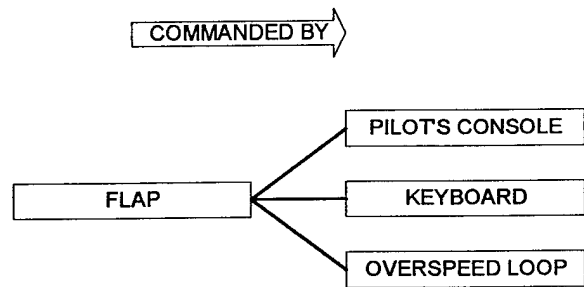
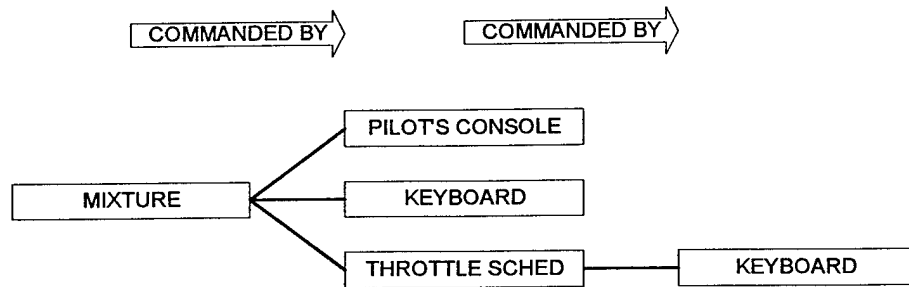

GLOBAL AUTOPILOT STATUS

A global variable affects collective enabling of all autopilot loops. It has 3 possible values:

1. OFF

The pilot's console controls all servoes directly, except that throttle throw and rate limiting may be activated from the keyboard.

2. ON

Any of the possible control paths can be selected from the keyboard (including manual command for each servo, in which case the pilot's control is the same as if the global autopilot status were **OFF**).

3. SAFE

SAFE status is expected to be used only when a failure occurs somewhere in the system. It is like **ON** except for two points:

1. When **SAFE** is selected, a check is made of the status and set point of each autopilot loop. If any is not safe then a new value is set (but may subsequently be changed from the keyboard).
2. The pilot's console controls switching between **ON** and **OFF**, the idea being that if the pilot sees autopilot behaviour that he doesn't like, then he can immediately switch to manual control. When **SAFE**, on the other hand, the pilot's switch is masked.

RESPONSIBILITY FOR CHANGING GLOBAL AUTOPILOT STATUS			
OFF → ON	pilot (gnd TT8)	ON → OFF	pilot (gnd TT8)
OFF → SAFE	kbd (gnd PC) or a/c	SAFE → OFF	disallowed
ON → SAFE	kbd (gnd PC) or a/c	SAFE → ON	kbd (gnd PC)*

* however the ground TT8 will set status from **SAFE** to **ON** if its link to the ground PC fails.

1. Ground Tattletale

Control of global autopilot status normally rests with the ground Tattletale. Switching between **ON** and **OFF** is commanded by the pilot's "retract" switch, which sets the width of one pulse in a regular PPM series. The ground TT checks this pulse whenever it has not been notified of a **SAFE** status by either the flight computer or the ground PC. Thus if the last reported status is **ON**, then the ground TT checks whether the switch pulse width is within a specified small tolerance of the **OFF** value. If so it uplinks the new status to the the flight computer (which, when communications work properly, immediately echoes it back to the ground PC). Conversely if the last reported status is **OFF**, then it is switched to **ON** if the switch pulse is not within tolerance of the **OFF** value.

The ground TT furthermore monitors all autopilot-status traffic to determine whether the flight computer expects flight-control commands from the pilot's console. It sends these commands whenever

1. global status is **OFF**; or
2. any of the airspeed, yaw rate, altitude, mixture, or flap ("glidepath") loops is set **OFF** (**MANUAL_SERVO_CMD**) or **SA** (**MANUAL_LOOP_CMD**).

Provision for the ground TT to change status from **SAFE** to **ON** is made for one particularly unusual situation, in which not only has **SAFE** been set, but also the link to the PC has failed. In that case individual loops are set in safe configuration, but global status is set either **ON** or **OFF** according to the position of the pilot's switch.

2. Flight computer

The flight computer is able to change the global status to **SAFE**, and will do so if, and only if, either (1) no uplink traffic is received within a specified interval (typically 10 sec); or (2) pilot inputs are expected but not received within a specified interval (typically 400 msec). Upon switching to **SAFE**, the flight computer will furthermore set individual autopilot loops as follows.

1. Airspeed loop **ON**, and command with pitot pressure commanded to establish a safe lift coefficient at the estimated aircraft gross weight. A typical safe C_L would be 0.75, which at 12 kg gross weight would correspond to about 22 m/s at sea level.
2. Altitude loop **ON**
3. If the last-commanded flight plan segment is valid, then
 - 3.1 it will set the altitude command to the maximum for that segment
 - 3.2 if the current altitude is above a specified minimum for tracking, it will enable tracking on that segment
 - 3.3 if the current altitude is lower than the specified minimum, it will command zero yaw rate, and set a flag for enabling the tracker as soon as the altitude is sufficient
4. If the last commanded flight plan segment is not valid, then
 - 4.1 if the current altitude is above the tracking minimum, then it will command a shallow turn
 - 4.2 if not, then it will command zero yaw rate, and set a flag for commanding a shallow turn as soon as the altitude is sufficient.

3. Ground PC

The ground PC is able to set autopilot status to **SAFE** under one of the following anomalous conditions:

1. Upon a **SAFE** command from the keyboard (presumably because the flight engineer has decided that pilot inputs are unacceptable);
2. Upon detecting communications failure.

In either case individual loops are put into to their safe status, and notification is sent to the flight computer. The keyboard can remove **SAFE** status by commanding the status to **ON**.

SETTING FLIGHT CONTROL CHANNELS FROM THE KEYBOARD

The status of each control channel is set by a 2-bit wide field in the `AP_Status` variable. The least-significant bit (`LOOP_ON_MASK`) indicates whether the loop is on or off, and the most-significant-bit (`KBD_CMD_MASK`) indicates whether the command source is the keyboard or the pilot's console. These bits may be set via the I/O table for autopilot status. Input will be accepted only if is considered safe and valid:

1. servo throws must be between 0 and 1
2. true airspeed commands must correspond to a safe C_L at the currently-calculated aircraft weight and ambient density. (e.g. $0.15 < C_L < 1.0$; cf the following table)
3. yaw rate magnitude must be comfortably less than g/V , which is the physical limit for a coordinated turn. (*Turn* rate may be quite large at large bank angle, but *yaw* rate asymptotes to this value.) Note that the turn-rate limit is calculated using the currently-commanded true airspeed.
4. rpm must be within reasonable upper and lower bounds
5. altitude must be no lower than the specified minimum tracking altitude

Elevator/airspeed

to control	from	set <code>AP_Status.pitot</code> to	by setting airspeed field to
elevator	pilot's console	<code>MANUAL_SERVO_CMD</code>	"off"
pitot pressure	pilot's console	<code>MANUAL_LOOP_CMD</code>	"sa"
pitot pressure	keyboard	<code>KBD_LOOP_CMD</code>	desired TAS [m/s]*
		<code>KBD_SERVO_CMD</code> is invalid	

* whenever a new airspeed is commanded from the keyboard, new autopilot gains are calculated by the flight computer and reported to the ground PC.

Aileron/rudder/yaw rate

to control	from	set	by setting field	to
aileron/ rudder	pilot's console	AP Status.yaw rate = MANUAL_SERVO_CMD AP Status.track = MANUAL_SERVO_CMD	turn rate	"off"
yaw rate	pilot's console	AP Status.yaw rate = MANUAL_LOOP_CMD AP Status.track = MANUAL_SERVO_CMD	turn rate	"sa"
yaw rate	keyboard	AP Status.yaw rate = KBD_LOOP_CMD AP Status.track = MANUAL_SERVO_CMD	turn rate	desired rate [deg/s]
yaw rate	tracking autopilot	AP Status.yaw rate = KBD_LOOP_CMD AP Status.track = KBD_LOOP_CMD	track	valid FP segment index
other combinations are invalid				

If the "track" field is set from a flight-plan segment number to "off", then the yaw-rate loop remains ON and set for a shallow turn

Mixture

to control	from	set AP_Status.mixture to	by setting mixture field to
mixture	pilot's console	MANUAL_SERVO_CMD	"off"
mixture	keyboard	KBD_SERVO_CMD	fractional throw (0 to 1)
mixture	throttle sched	KBD_LOOP_CMD	"on"
MANUAL_LOOP_CMD is invalid			

Flap/airbrake

to control	from	set AP_Status.glidepath to	by setting flap field to
flap	pilot's console	MANUAL_SERVO_CMD	"off"
flap	keyboard	any other value	fractional servo throw (0 to 1)

If the airspeed loop is ON, and **AP_Status.glidepath** \neq **MANUAL_SERVO_CMD**, then flaps are fully extended for braking whenever pitot pressure exceeds the commanded value by a specified amount.

Throttle/altitude/climb rate/rpm

to control	from	set	by setting field	to
throttle	pilot's console	AP Status.Pstatic = MANUAL_SERVO_CMD AP Status.rpm = MANUAL_SERVO_CMD	rpm, altitude, and climb rate	"off"
throttle	keyboard	AP Status.Pstatic = MANUAL_SERVO_CMD AP Status.rpm = KBD_SERVO_CMD	rpm	fractional servo throw (0 to 1)
rpm	keyboard	AP Status.Pstatic = MANUAL_SERVO_CMD AP Status.rpm = KBD_LOOP_CMD	rpm	desired rpm
static pressure rate	pilot's console	AP Status.Pstatic = MANUAL_LOOP_CMD AP Status.rpm = MANUAL_SERVO_CMD	climb rate	"SA"
static pressure rate	keyboard	AP Status.Pstatic = KBD_LOOP_CMD AP Status.rpm = MANUAL_SERVO_CMD	climb rate	desired rate [m/s]
current static pressure	keyboard	AP Status.Pstatic = KBD_LOOP_CMD AP Status.rpm = MANUAL_SERVO_CMD	climb rate	0
selected static pressure	keyboard	AP Status.Pstatic = KBD_LOOP_CMD AP Status.rpm = MANUAL_SERVO_CMD	altitude	selected altitude [m], provided that flight- plan tracking is OFF
static pressure or pressure band	flight plan	AP Status.Pstatic = KBD_LOOP_CMD AP Status.rpm = MANUAL_SERVO_CMD	altitude or climb rate	any valid altitude [m] or any valid rate [m/s]

Safety_Limits ON AUTOPILOT MODES

Selection of autopilot modes and target values is regulated according to variables in the **Safety_Limits** data structure. These include the following.

Safety_Limits variables involved in autopilot selection

structure member	specifies	typical value
max_CL_cmd	C_L at minimum commanded airspeed	1.0
min_CL_cmd	C_L at maximum commanded airspeed	0.15
safe_CL	C_L for SAFE airspeed	0.75
max_yaw_frac	$\max r_d (V_c/g)$	0.4
min_track_alt	min altitude [m] for FP tracking	as needed
brake_dPitot_Pa	$(q-q_c)$ [Pa] for flap extension	200 Pa
Vl_pitot_Pa	min q for airspeed loop execution*	100 Pa
max_g	normal acceleration limit [g]	1.4
link_msec	T [msec] before flagging uplink failure	10,000 msec
Pcmd_msec	T [msec] before flagging manual-command failure	400 msec
gps_msec	T [msec] before flagging GPS failure**	10,000 msec

* If the airspeed loop is **ON** at a lower pitot pressure, then the elevator will be set at neutral. This will prevent catastrophic pitch-down in the event that the pitot measurement fails to a low value.

** If the tracking loop is **ON** and the GPS fix has not been updated for **gps_msec**, then a shallow turn will be commanded.

AEROSONDE HALF-DUPLEX COMMUNICATIONS PROTOCOLS

Kurt Ziegler

30 March 1995

Aerosonde communications are exchanged among three nodes: the ground PC, the staging module, and the aerosonde flight computer. All communications are in packet form. The protocol provides for message routing, flow control, multiple-packet burst transmission, and error detection using the Cyclic Redundancy Check (CRC) algorithm. The staging module serves as the network controller, maintaining a link to both the aerosonde and the ground station, and managing the transfer of data between the two. In addition, the staging module accepts manual-control commands from the pilot console, and is responsible for uplinking them to the aerosonde in a timely fashion.

Radio link

A single radio frequency is available, so radio exchanges must be half-duplex. A state machine maintains a half-duplex protocol as illustrated in the accompanying figure. Communications are organized into 200 msec frames, matching the period of the autopilot loops running on the aerosonde. Precise UTC is kept on both the aerosonde and staging module using their respective GPSs, and this provides synchronization. (In the event of GPS failure, the aerosonde synchronizes on a packet sent by the staging module at the beginning of each communication frame.)

Flow control is signalled by a type assigned to each packet, which affects processing by the receiver. A communication frame always begins with a sync packet sent by the staging module. If the staging module has additional packets queued for transmission, then the sync packet and those following are sent with type `PT_BDCST`. This tells the aerosonde that more packets are on the way. When the aerosonde sees a packet of this type it will not respond with an acknowledge, but instead remain in the receive state.

When the staging module either empties its queue or determines that no more packets will fit in the current frame, it sends a final packet with type `PT_MULT`. This tells the aerosonde to begin sending to the staging module. The aerosonde determines how many pending packets will fit in the remainder of the frame, and sends the group in a burst. Each packet is tagged with a sequence number, with the last packet in the burst given number zero. The staging module interprets this packet as an acknowledge, indicating normal termination of handshaking for the frame. Depending upon how the downlink packets are addressed, they may be processed by the staging module or passed on to the ground PC.

If the staging module determines that there is too little time left in the frame for a multiple-packet downlink, it can send a packet of type `PT_RQST`. The aerosonde responds immediately with a packet of type `PT_ACK`, which terminates the handshaking.

At the end of the communication frame, after the handshaking cycle is terminated, the staging module samples the pilot console and sends manual-control information (which the aerosonde may or may not require) in a packet of type PT_BRDCST. The transmission of this packet is timed to coincide with the beginning of the flight-control loop on the aerosonde, thereby minimizing latencies between pilot input and corresponding servo movement. The manual-control packet is sent even if handshaking is not terminated properly.

A guard period is maintained at the end of each communication frame. During this period no communication is initiated, thus providing a buffer to ensure that packet transmission cannot overrun the frame. With GPS synchronization the guard period is about 5 msec.

Staging-PC serial link

The PC and staging module communicate via standard full-duplex RS-232. No handshaking is required. Packeting is identical to that on the radio link, but only a subset of packet types is used.

Most packets initiated by the ground station are addressed to the aerosonde. The ground station can send packets of type PT_BDCST, which permit the staging module flexibility in queuing the packet, or of type PT_RQST, which force a strictly acknowledged handshake between staging and aerosonde.

The ground station may also address packets to the staging module. The only packet currently sent is an "alive" message to verify that the link is in working order.

Aerosonde Serial Network

Normal Synchronous Communication

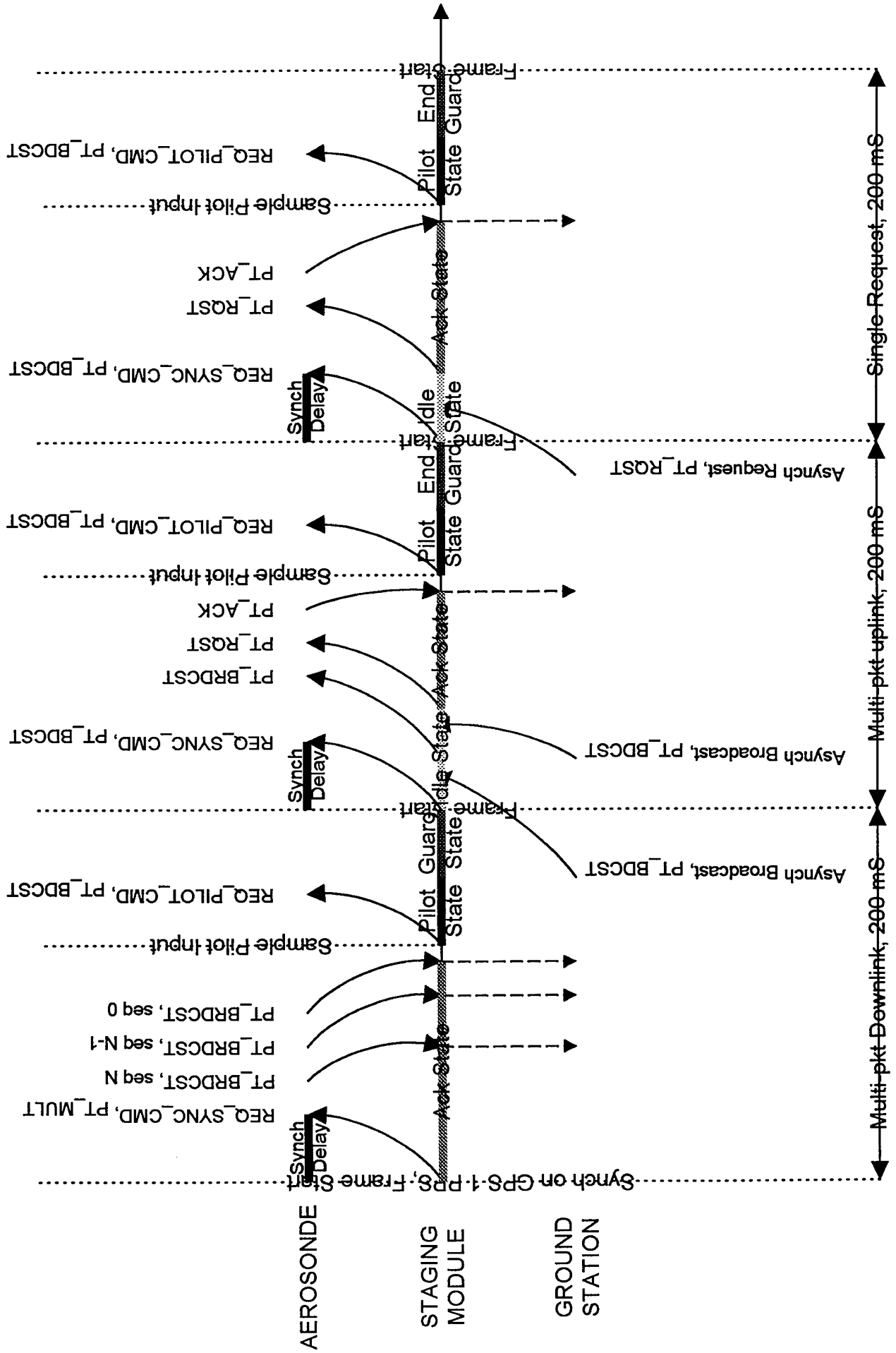

AEROSONDE COMMUNICATIONS FAILURE AND RECOVERY

Tad McGeer

17 February 1995

DETECTION

Communications failure will be assumed if no message is received within a specified interval, say 1 sec. Timing-out could be caused by a variety of problems, including

1. blocked frequency
2. signal fading
3. genuine failure of the aircraft or ground station radio
4. failure of a transmitter or receiver, while everything else still works
5. failure of support equipment on the ground, *e.g.* power, cabling, UART, etc
6. software bug or crash

The procedures outlined below are intended to retrieve the situation if the problem is channel blockage or fading, while not making things worse if the problem is something else (*e.g.* by losing half the link if it is still working, or by dwelling on a frequency which we ought not to be using.)

It is important to note that assumption of comm failure by one side does *not* imply that the other side has reached the same conclusion. On the one hand, if only the downlink were to fail, then the aerosonde would not detect the problem on its own. Of course it would if the ground side switched to another frequency, since it would then appear as if the uplink had failed as well. However it would be better for the ground side first to announce its intentions explicitly.. Similarly if only the uplink were to fail, then the ground side would continue to receive "broadcast" messages and hence not have a comm timeout (unless only acknowledgements were allowed to reset the timer.) Again it would be best for the aerosonde to make a blind announcement.

IMMEDIATE ACTION

1. Time-out detected by the ground Tattletale

1. Ground TT switches to high RF power, if not already there, and commands the aerosonde to do the same.
2. Ground TT reports apparent downlink failure to the ground PC, and announces that recovery action will be taken imminently unless comm is reestablished or the operator commands otherwise.
3. The aircraft should be commanded to do something which can quickly be checked visually or audibly - *e.g.* flashing lights; changing throttle setting; turning; responding to manual control. The light-flashing command can be issued automatically by the ground TT; the others would have to be initiated by the crew, and quickly.
4. If the uplink turns out to be working, then the crew should command communication on the primary frequency, and land ASAP.
5. If the uplink is apparently not working, then the ground TT should
 - a) command the aerosonde to begin the comm-failure protocol
 - b) begin the comm-failure protocol, *q.v.*

2. Time-out detected by the aerosonde

1. Aerosonde switches to high RF power, if not already there.
2. Aerosonde makes itself SAFE for autonomous operation:
 - a) airspeed, altitude, and yaw-rate loops ON

- b) tracking ON, if altitude is sufficient.. Otherwise. climb straight-ahead to sufficient altitude, and then switch to tracking ON. Tracking should start on the last commanded flight-plan segment, if it is valid, or otherwise on the first valid segment on the segment list
- c) lights ON
- 3. Aerosonde announces that it is starting the comm-failure protocol
- 4. Aerosonde begins the comm-failure protocol

FAILURE-RECOVERY PROTOCOL

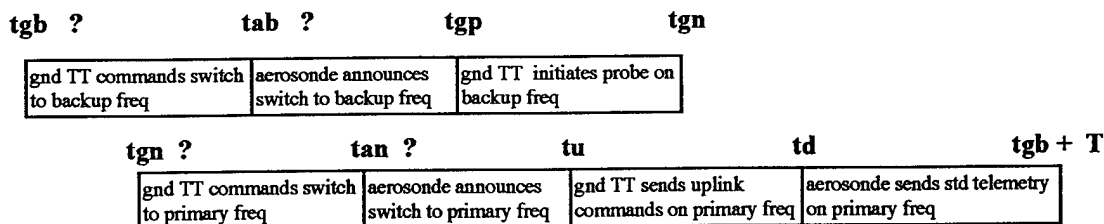

In the hope of finding a frequency that works, the aerosonde and ground station should cycle through the protocol illustrated in the figure above. The protocol depends upon synchronisation between ground and aircraft, which in turn depends upon each side having established (via GPS) an accurate absolute clock. Each side will have a the same table of backup frequencies and time slots:

backup freq	UTC mod NT
Freq 0	0
Freq 1	Tb
Freq 2	2 Tb
...	...
Freq N-1	(N-1)Tb

Given this table and an accurate clock, the protocol is as follows:

1. Establish a timer synchronised to UTC as provided by GPS
2. Timing starts at **tgb**. At this time
 - a) Each side sets a timer for **tgp**
 - b) Each side sets its modem to the appropriate backup frequency
 - c) The ground TT reports the new frequency to the ground PC
 - d) The ground TT attempts to get acknowledgement on the new frequency
 - i) It sends a test message
 - ii) It awaits acknowledgement for a specified interval
 - iii) It repeats i-ii some specified number of times, or until contact is established
3. If acknowledgement is received, then
 - a) The ground TT commands the aerosonde to stop the comm failure protocol
 - b) The ground TT stops its own protocol
 - c) The ground TT command the aerosonde to store the current frequency as the first-choice backup
4. Otherwise, when the timer reaches **tu**
 - a) Each side sets a timer for the **td**
 - b) Each side sets its modem to the primary frequency
 - c) The ground side sends queued packets until timeout at **td**
 - d) If acknowledgement is received then (4) above
5. When the timer reaches **td**

- a) Each side sets a timer for $t_{gb}+T$
- b) The aerosonde sends queued packets until timeout at $t_{gb}+T$
6. Repeat 2-6 some specified number of times with the first-choice backup frequency. If that fails, Set an index into the backup-frequency table based on the current UTC and repeat 2-6 until all backup frequencies have been tried.
7. After all backup frequencies have been tried without success, set a time to repeat the full protocol if comm is not reestablished in the interim (as indicated by a lost-link flag), and continue with only steps 5 and 6.