

IMPLEMENTATION DOCUMENT
FOR
RAIL CLASSIFICATION YARD/MOTOR POOL AREA IRA

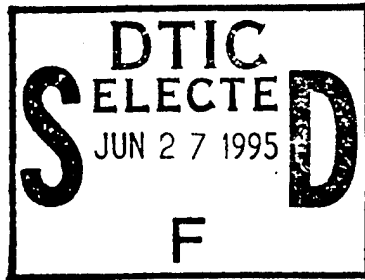

VOLUME 1 GENERAL
VOLUME 2 SPECIFICATIONS

January 1991



This document has been approved
for public release and sale; its
distribution is unlimited.

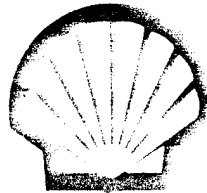

19950623 054

Shell Oil Company

DTIC QUALITY INSPECTED 5

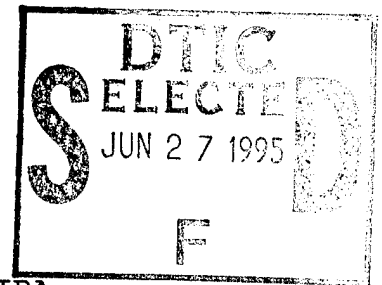

IMPLEMENTATION DOCUMENT
FOR
RAIL CLASSIFICATION YARD/MOTOR POOL AREA IRA

VOLUME 1 GENERAL
VOLUME 2 SPECIFICATIONS

January 1991

Prepared by
Morrison Knudsen Corporation
Environmental Services Group
Denver, Colorado 80203

Prepared for
Shell Oil Company
Denver, Colorado 80203

This document has been approved
for public release and sale; its
distribution is unlimited.

The use of trade names in this report does not constitute an official endorsement or approval of the use of such commercial products. The report may not be cited for purposes of advertisement.

**Rocky Mountain Arsenal
Information Center
Commerce City, Colorado**

REPORT DOCUMENTATION PAGE

Form Approved
OMB No. 0704-0188

Public reporting burden for this collection of information is estimated to average 1 hour per response, including the time for reviewing instructions, searching existing data sources, gathering and maintaining the data needed, and completing and reviewing the collection of information. Send comments regarding this burden estimate or any other aspect of this collection of information, including suggestions for reducing this burden, to Washington Headquarters Services, Directorate for Information Operations and Reports, 1215 Jefferson Davis Highway, Suite 1204, Arlington, VA 22202-4302, and to the Office of Management and Budget, Paperwork Reduction Project (0704-0188), Washington, DC 20503.

1. AGENCY USE ONLY (Leave blank)	2. REPORT DATE 01/00/91	3. REPORT TYPE AND DATES COVERED
----------------------------------	----------------------------	----------------------------------

4. TITLE AND SUBTITLE IMPLEMENTATION DOCUMENT FOR RAIL CLASSIFICATION YARD/MOTOR POOL AREA Vol. 1	5. FUNDING NUMBERS
---	--------------------

6. AUTHOR(S)	
--------------	--

7. PERFORMING ORGANIZATION NAME(S) AND ADDRESS(ES) MORRISON KNUDSEN CORPORATION DENVER, CO	8. PERFORMING ORGANIZATION REPORT NUMBER 91032R01
--	--

9. SPONSORING/MONITORING AGENCY NAME(S) AND ADDRESS(ES) SHELL OIL COMPANY DENVER, CO	10. SPONSORING/MONITORING AGENCY REPORT NUMBER
--	--

11. SUPPLEMENTARY NOTES

12a. DISTRIBUTION/AVAILABILITY STATEMENT APPROVED FOR PUBLIC RELEASE; DISTRIBUTION IS UNLIMITED	12b. DISTRIBUTION CODE
--	------------------------

13. ABSTRACT (Maximum 200 words) THE INTERIM RESPONSE ACTION FOR THE RAIL CLASSIFICATION YARD/MOTOR POOL AREA WILL INCLUDE: <ol style="list-style-type: none"> 1. GROUND WATER EXTRACTION SYSTEMS IN THE ALLUVIAL CHANNELS OF THE RAIL YARD AND MOTOR POOL AREAS 2. PIPELINE TO TRANSPORT THE EXTRACTED WATER TO THE IRONDALE CONTAINMENT SYSTEM TREATMENT FACILITY 3. MODIFICATIONS TO THE TREATMENT FACILITY TO ALLOW FOR THE ADDITIONAL FLOW. VOLUME I OF THIS IMPLEMENTATION DOCUMENT CONTAINS: <ol style="list-style-type: none"> 1. MOU BETWEEN THE ARMY AND SHELL CONCERNING SHELL'S PARTICIPATION IN THE IRA'S 2. CONSTRUCTION WORK PLAN 3. COST ESTIMATES 4. TASK SPECIFIC HEALTH AND SAFETY PLAN.

14. SUBJECT TERMS COST, HEALTH AND SAFETY, SPECIFICATIONS, DESIGN, IRA L	15. NUMBER OF PAGES
	16. PRICE CODE

17. SECURITY CLASSIFICATION OF REPORT UNCLASSIFIED	18. SECURITY CLASSIFICATION OF THIS PAGE	19. SECURITY CLASSIFICATION OF ABSTRACT	20. LIMITATION OF ABSTRACT
---	--	---	----------------------------

IMPLEMENTATION DOCUMENT
FOR
RAIL CLASSIFICATION YARD/MOTOR POOL AREA IRA

VOLUME 1 GENERAL

January 1991

Prepared by
Morrison Knudsen Corporation
Environmental Services Group
Denver, Colorado 80203

Prepared for
Shell Oil Company
Denver, Colorado 80203

RAIL CLASSIFICATION YARD/MOTOR POOL AREA IRA
IMPLEMENTATION DOCUMENT

TABLE OF CONTENTS
VOLUME 1

<u>SECTION</u>	<u>PAGE</u>
1.0 Introduction.....	1
2.0 Memorandum of Understanding.....	4
3.0 Construction Work Plan.....	21
4.0 Estimated Cost and Basis of the Estimate.....	24
5.0 Schedule.....	26
6.0 Health and Safety Plan.....	1 to 9

Volume 2
Engineering Specifications

Volume 3
Engineering Drawings

Section 1.0

RAIL CLASSIFICATION YARD/MOTOR POOL AREA IRA

INTRODUCTION

The Interim Response Action (IRA) for the Rail Classification Yard/Motor Pool Area is being conducted as part of the IRA Process for the Rocky Mountain Arsenal (RMA) in accordance with the June 5, 1987 report to the court United States v. Shell Oil Company and the Federal Facility Agreement effective February 17, 1989.

The Decision Document for the Rail Classification Yard IRA became final in March, 1990. The Decision Document for the Motor Pool Area IRA became final in February, 1990. The lead role for the groundwater extraction portion of the Motor Pool Area IRA was transferred from the Army to Shell on May 25, 1990. The detailed design incorporates the concepts proposed in the Final Decision Documents and is based on the additional data developed during preliminary engineering site investigations. The conceptual design was issued as a Preliminary Engineering Design Package on July 2, 1990 for review and comment by the parties. Comments from this review were discussed and resolved at a meeting of the Parties on July 9, 1990. As discussed with the parties during meetings held in October 1990, this IRA is being expanded to include modifications of the Irondale Containment System (ICS). A construction cost estimate and schedule have been prepared and are included. The cost of construction is estimated to be \$2,500,000 and the basis of the estimate is given in Section 4. The deadline for completion of this project (an "IRA Deadline" under the Federal Facility Agreement) is April 30, 1992, subject to extension as described in Section XXVI of the Federal Facility Agreement. Intermediate dates shown in this document comprise the "Schedule" (as defined in the Federal Facility Agreement) and are not "Deadlines" under the Federal Facility Agreement.

The Rail Classification Yard/ Motor Pool Area IRA will consist of the following:

1. Groundwater extraction systems in the alluvium underlying the Rail Classification Yard and Motor Pool Area.
2. Addition of extraction well to the Irondale Containment System.
3. A metering station at the convergence of the two extractions system pipelines.
4. A pipeline to transport the extracted water to the Irondale Containment System (ICS) treatment facility.
5. Reconfiguration of the existing ICS influent sump to accept the expanded flow. The maximum expected flow from this IRA is 530 gpm.
6. Reconfiguration of the existing carbon treatment process flow streams to allow for operation of all three adsorbers simultaneously. This entails the addition of pre and post bag-filtration units to the third existing carbon adsorber stream.
7. Addition of a third bag guard-filtration unit.
8. Addition of a new effluent sump.
9. Addition of a new process water decant sump.
10. Addition of a new row of injection wells for the ICS.
11. Addition of alluvial monitoring wells in the vicinity of the extraction systems.

12. Addition and/or upgrading access roads in the area of the extraction systems.
13. Site grading and utility distribution systems.

MEMORANDUM OF UNDERSTANDING BETWEEN
THE DEPARTMENT OF THE ARMY AND SHELL OIL COMPANY
WITH RESPECT TO
RESPONSE ACTION WORK CONDUCTED PURSUANT TO THE
FEDERAL FACILITY AGREEMENT

I. PARTIES

This Memorandum of Understanding ("MOU") specifies the cooperative undertakings which are to occur between the Army (a potentially responsible party under CERCLA) and Shell (a potentially responsible party under CERCLA) with respect to any Scope of Work developed pursuant to the Federal Facility Agreement now or hereafter attached as an exhibit to this MOU.

II. PURPOSE

The purpose of this MOU is to provide an appropriate basis pursuant to the Federal Facility Agreement for Shell to participate in the expeditious (a) assessment, selection, design and implementation of an IRA or (b) operation and maintenance of any Response Action Structure.

III. DEFINITIONS

The following terms, used in the MOU, shall have the meanings indicated:

(a) "Army" means the United States Department of the Army, and any successors or assigns thereof, and any agency, office or other subdivision thereof; and includes the officers, members, employees and agents of the Army when acting within the scope of their authority.

(b) "Arsenal" means the United States property known as the Rocky Mountain Arsenal and described more particularly on Exhibit A hereto.

(c) "CERCLA" means the Comprehensive Environmental Response, Compensation and Liability Act of 1980, as amended by the Superfund Amendments and Reauthorization Act of 1986.

(d) "Contractor" means any commercial party not a part of Shell with which Shell contracts for the performance of Response Action work pursuant to this MOU. Unless otherwise indicated, the term also includes a subcontractor retained by a prime Contractor or another subcontractor.

(e) "Federal Facility Agreement" means the Federal Facility Agreement for Rocky Mountain Arsenal, effective February 17, 1989, including all exhibits thereto (and any amendments or modifications thereof or supplements thereto).

(f) "Financial Manual" means the document identified in paragraph 7.4 of the Settlement Agreement.

(g) "Force Majeure" means any event arising from causes beyond the control of an Organization that causes a delay in or prevents the performance of any obligation under this MOU. "Force Majeure" includes, but is not limited to: acts of God; fire; war; insurrection; civil disturbance; explosion; unanticipated breakage or accident to machinery, equipment or lines of pipe, despite diligent maintenance; adverse weather conditions which could not be reasonably anticipated; unusual delay in transportation; earthquake; restraint by court order or order of public authority; inability to obtain, at reasonable cost and after exercise of reasonable diligence, any necessary authorizations, approvals, permits or licenses as a result of the action or inaction of any governmental agency or authority other than the Army; delays caused by compliance with applicable statutes or regulations governing contracting, procurement or acquisition procedures, despite the exercise of reasonable diligence; and insufficient availability of appropriated funds, if the Army shall have made timely request for such funds as part of the budgetary process. "Force Majeure" also includes any strike or labor dispute, whether or not within the control of the Organization affected thereby, but shall not include increased costs or expenses of Response Actions, whether or not anticipated at the time such Response Actions were initiated.

(h) "IRA" means an Interim Response Action identified in Section XXII of the Federal Facility Agreement.

(i) "Lead Party" means the Organization that is designated with responsibility, in accordance with Section XLIII of the Federal Facility Agreement, for conducting a Response Action, or any part thereof.

(j) "MOU" or "Memorandum of Understanding" means to this entire document and any amendments or modifications hereof and supplements hereto, and all documents incorporated herein by reference.

(k) "NCP" means the National Oil and Hazardous Substances Pollution Contingency Plan, 50 Fed. Reg. 47912 (1985) (effective February 18, 1986), and all amendments thereto which are not inconsistent with CERCLA and which are effective and applicable to any activity undertaken pursuant to this MOU.

(l) "Organization" means the Army, EPA or Shell.

(m) "Party" means the Army or Shell; "Parties" means the Army and Shell.

(n) "Response Action" has the same meaning as "Respond" or "Response" as defined in Section 101(25) of CERCLA, 42 U.S.C. § 9601(25).

(o) "Scope of Work" means a document identified in Part VI by which any Response Action work for which Shell is the Lead Party shall be conducted.

(p) "Settlement Agreement" means the "Settlement Agreement Between the United States and Shell Oil Company Concerning Rocky Mountain Arsenal," effective February 17, 1989, including all exhibits thereto (and any amendments or modifications thereof or supplements thereto).

(q) "Shell" means (a) Shell Oil Company and its successors and assigns, (b) the divisions thereof, including Shell Chemical Company, (c) Julius Hyman & Co., and (d) Shell Chemical Corporation; and includes the officers, employees and agents of Shell when acting within the scope of their authority.

All other capitalized terms used in this MOU shall have the same meaning as in the Federal Facility Agreement or the Settlement Agreement or the meaning specified in an executed Scope of Work.

IV. SCOPE OF MOU

This MOU, the Federal Facility Agreement and the Settlement Agreement constitute the entire understanding between the Army and Shell with respect to Shell's assisting the Army in the Response Action work described in an executed Scope of Work, except for any subsequently executed Scope of Work which the Parties may execute with respect to such Response Action work; constitute the sole conditions controlling Shell's participation in such Response Action work; and with respect to such Response Action work, supersede any other agreement(s) between the Parties. In the event a conflict between the provisions of the Federal Facility Agreement and the Settlement Agreement and this MOU, the provisions of the Federal Facility Agreement and the Settlement Agreement shall govern.

V. OPERATION OF MOU

By their execution of this MOU, each of the Parties acknowledges and agrees as follows:

(a) The provision of the Response Action work pursuant to this MOU is a reasonable and appropriate contribution to the assessment, selection, design and implementation of Response Actions that are protective of the present and future public health and the environment.

(b) The Army's actions under this MOU are not inconsistent with the NCP.

(c) Shell's actions under this MOU, to the extent certified by the Army pursuant to Subpart VI.E., are consistent with the NCP.

(d) This MOU does not operate to establish or to excuse any Shell or Army liability under any law, the Federal Facility Agreement or the Settlement Agreement, except to the extent provided in this MOU.

(e) This MOU does not operate to render Shell or any of its Contractors a CERCLA response action contractor.

(f) This MOU does not operate to expand or limit any of the rights and obligations of the Army as Lead Agency or Shell as Lead Party under any law or the Federal Facility Agreement.

(g) Unless otherwise provided in a Scope of Work, upon acceptance of the Response Action work pursuant to Subpart VI.E, title to any Response Action Structure including all related systems and facilities constructed as a part of that Response Action work shall pass to the United States.

(h) The Army shall be solely responsible for obtaining necessary permits, if any, and for establishing substantive compliance with all permitting requirements pursuant to Section 121(e) of CERCLA, 42 U.S.C. 9621(c), for any activities conducted pursuant to this MOU. However, Shell shall provide any necessary technical support necessary for the Army to obtain such permits.

(i) This MOU has no precedential or controlling effect with respect to any matter which is not expressly the subject of this MOU.

(j) This MOU does not create or impose any obligations or responsibilities on the Parties or relieve them of any obligations or responsibilities, except to the extent expressly provided herein.

VI. SHELL'S PERFORMANCE OF RESPONSE ACTION WORK

A. Development of Scope of Work: Pursuant to Section XLIII of the Federal Facility Agreement, the Army and Shell shall develop Scopes of Work by which Response Action Work for which Shell is the Lead Party shall be conducted. A Scope of Work shall include any required data or specifications for the Response Action work to be performed, a projected schedule for completion and a statement as to the appropriate limits of insurance to be maintained by Shell pursuant to Part VII.

B. Incorporation into this MOU: Any Scope of Work developed pursuant to Subpart VI.A and executed by the Army and Shell, and all the terms and conditions therein are incorporated by reference into this MOU.

C. Performance of Work: Upon execution of the Scope of Work by the Army and Shell, Shell shall immediately commence, in consultation and cooperation with the Army, as provided in the Consent Decree, to perform the Response Action work described in the Scope of Work.

D. Hiring of Contractor: Subject to the approval of the Army, Shell may hire at its sole expense, subject to Part VII, a Contractor to perform any Response Action work described in a Scope of Work. A Contractor may be terminated by Shell with the approval of the Army, which approval shall not be unreasonably withheld. Any disagreement with respect to such termination not resolved informally shall be resolved in accordance with the provisions of Part XIII.

E. Acceptance of Work: 1. If Shell performs the Response Action work in accordance with the specifications set forth in the applicable Scope of Work, the Army shall accept Shell's work pursuant to this MOU. The Army shall act promptly to accept Shell's work, and acceptance shall not be unreasonably withheld. Should the Army decline acceptance, it shall promptly notify Shell in writing, stating with specificity the factual, technical and legal bases for such nonacceptance.

2. If Shell concludes that the Army is in error for treating Shell's performance as incomplete or unacceptable for any other reason, Shell shall give notice in writing, within ten business days of the receipt of the Army's written notification, that Shell disagrees. Any such disagreement, if not resolved informally, shall be resolved in accordance with the provisions in Part XIII.

VII. SHELL INSURANCE OBLIGATIONS

Shell shall maintain such insurance or self-insurance as is required by statute or regulation to cover any claims which may reasonably be anticipated to be made as a result of Response Action work done pursuant to any Scope of Work attached as an exhibit to this MOU. At a minimum, Shell shall, at its sole option, procure insurance, maintain insurance or self-insure sufficiently to cover the following:

1. Worker's compensation and occupational disease insurance in amounts sufficient to satisfy applicable state law;
2. Employer's liability insurance in the minimum amount of \$100,000 per occurrence; and
3. Comprehensive general liability insurance for bodily injury, death or loss of or damage to property of third persons in the minimum amount of \$100,000 per occurrence.

Upon this MOU becoming effective, Shell shall promptly provide the Army with an affidavit that Shell is in compliance with the minimum requirements of this Part. Upon the signing of a Scope of Work, Shell shall promptly provide the Army with an affidavit that Shell is in compliance with this Part as to that Scope of Work. Upon request, Shell shall discuss with the Army the manner in which Shell will fulfill its obligations under this Part.

VIII. ARMY SUPPLEMENTATION OF SHELL INSURANCE

If the Response Action work being performed is an Army-Only Response Action, as defined in the Settlement Agreement, the Army shall release, defend, indemnify and hold harmless Shell from all losses, fines, penalties, claims, suits, liabilities, judgments, or expenses (including expenses of litigation or settlement) (collectively hereinafter in this Part VIII, "claim") with respect to any death or injury to any person or loss of or damage to property to the extent that these result from the construction, operation, collapse, rupture or failure of any Response Action Structure, or any part thereof, after the Army's acceptance pursuant to Subpart VI.E. or the operation, collapse, rupture, failure or ineffectiveness of the Response Action Structure as a result of the construction, operation, collapse, rupture or failure of the Response Action work when such claim is not compensated by insurance or self-insurance, to the extent provided below:

- (a) Shell is not in material breach of this MOU with respect to the Scope of Work pursuant to which such Response

Action work was performed or such Response Action Structure was constructed;

(b) Any claim which is within the deductible amounts of Shell's insurance shall not be subject to this Part;

(c) Shell shall not be reimbursed for any claims (including expenses incidental to such claims) to the extent that they result, in whole or in part, from willful misconduct or recklessness by Shell;

(d) The Army may discharge its obligations under this Part by making payments directly to Shell or directly to any party to whom Shell may be liable upon obtaining a release from that party, which release provides adequate protection for Shell.

(e) If insurance coverage maintained in accordance with Part VII is reduced below the minimums specified in that Part without the Army's knowledge or approval, the liability of the Army under this MOU shall not be increased by reason of such reduction;

(f) To the extent that any claim against Shell may reasonably be expected to involve indemnification under this Part, Shell shall:

(1) promptly notify the Army of such claim against Shell;

(2) furnish evidence or proof of any claim covered by this Part in the manner and form reasonably requested by the Army; and

(3) immediately furnish the Army with copies of all pertinent papers received by Shell.

(g) To the extent that the amount of the claim is not determined to be in excess of the limits set forth in Part VII or to the extent that the amount of the claim cannot reasonably be determined to be or not to be in excess of those limits, Shell and the Army shall conduct a joint defense or settlement. Once it is determined that the amount of the claim is in excess of the limits set forth in Part VII, the Army shall direct and control such defense or settlement, with assistance by Shell as is acceptable to both Parties, and Shell shall execute any authorizations which the Army reasonably requires in connection with such settlement.

(h) Reimbursement for any claims under this Part shall not exceed appropriations available during the time that

such claims are represented by final judgments or by settlements approved in writing by the Department of Justice. This agreement to reimburse Shell for certain claims shall not be interpreted as implying that Congress shall, at a later date, appropriate funds sufficient to meet any deficiencies. During all times that claims remain unreimbursed due to lack of appropriated funds, the Army shall exert its best efforts to obtain appropriations for such reimbursement.

**IX. TREATMENT OF COSTS INCURRED
BY SHELL PURSUANT TO THIS MOU**

Any costs incurred by Shell pursuant to this MOU are Reimbursable Costs and shall be governed by the Settlement Agreement and the Financial Manual.

X. DELAY OR PREVENTION OF PERFORMANCE

A. As provided in the Consent Decree, if a Party is rendered unable, wholly or in part, by Force Majeure to carry out its obligations under this MOU, then upon that Party's giving written notice as provided in Subpart XI.C., the obligations of that Party, so far as they are affected by the event of Force Majeure therein specified, shall be suspended during the continuance of such cause, but for no longer period, and such cause shall be remedied so far as possible with all reasonable dispatch.

B. The settlement of a strike or other labor dispute shall be entirely within the discretion of the Party involved with such strike or labor dispute, and the requirement that any event of Force Majeure shall be remedied with all reasonable dispatch shall not require the settlement of a strike or labor dispute by acceding to the demands of the opposing party when such course is inadvisable in the discretion of the Party involved with such strike or labor dispute.

C. When circumstances are occurring or have occurred that delay the completion of any obligation, and a Party believes such circumstances constitute an event of Force Majeure, such Party shall notify the other Organizations in writing within 15 days after the notifying Party obtains information indicating that a delay will occur. Such notice shall include a detailed explanation of the reason(s) for and anticipated duration of the delay, the measures taken and to be taken to prevent or minimize the delay, and a schedule for implementation of such measures. Failure to provide notice in accordance with this paragraph within the required 15-day period shall constitute a waiver of any claim of Force Majeure with respect to any event of Force Majeure for which notice was not timely given.

D. If the Organizations cannot agree whether a delay is or was attributable to an event of Force Majeure, any Organization may invoke Dispute Resolution pursuant to Section X of the Settlement Agreement.

E. Scope of Work Modification: If performance of this MOU is delayed because any Party finds it necessary to make modifications to address an unanticipated occurrence which may cause a delay of more than two weeks, such modifications shall be developed and implemented by Shell in consultation and cooperation with the Army. Any disputes not resolved informally shall be resolved pursuant to the provisions of Part XIV. Further, if Shell anticipates the delay resulting from any such modifications will necessitate the extension of a Deadline, it shall request such an extension in accordance with Section XXVI of the Federal Facility Agreement.

F. Unaffected Activities: To the extent that the unanticipated occurrence does not necessitate delay in any discrete portion(s) of the activities provided in Part VI, such portion(s) of the activities shall proceed as originally provided in the MOU irrespective of the need for modification of other parts of the MOU.

XI. SHELL ACCESS TO ROCKY MOUNTAIN ARSENAL

Shell and its Contractors shall be afforded access to all relevant portions of the RMA in order to perform its obligations under the MOU pursuant to the terms and conditions of the Access and Use Agreement attached as Exhibit E to the Settlement Agreement until such time as the Army and Shell execute an applicable superseding agreement.

XII. DISPUTE RESOLUTION AND JUDICIAL REVIEW

A. Dispute Resolution: Any dispute which arises in connection with this MOU may be submitted for resolution pursuant to Section X of the Settlement Agreement. Prior to any such submission, Shell and the Army shall meet and attempt to resolve the dispute informally.

B. Judicial Review: 1. Judicial review of issues arising in connection with this MOU shall be obtained pursuant to Section XI of the Settlement Agreement.

2. The pendency of any dispute shall not affect the responsibility of the United States or Shell to continue their involvement in the assessment, selection, design and implementation of Response Actions, or discrete portions of Response Actions, not subject to such dispute.

XIII. GENERAL

A. Term: This MOU shall continue in effect as to a specific Scope of Work until the Army, pursuant to Subpart VI.E., accepts Shell's work pursuant to this MOU, and the reimbursement or payment has been made pursuant to Part IX.

B. Modification: Any provision of this MOU or of any Scope of Work may be modified at any time by both Parties' agreement. Any modification must: (1) be in writing; (2) show the date signed by the Parties; (3) specify that it is intended to modify this MOU; (4) state the provisions of the MOU to be modified; (5) state the new provisions; and (6) state when the new provisions are to be effective.

C. Effect of Execution: This MOU shall become effective on the later of its execution by the Parties or the entry of the Consent Decree. A Scope of Work shall become effective, final and binding upon its execution.

IN WITNESS WHEREOF, I have hereunder set my hand as an authorized representative of the United States Department of the Army.

Date: _____

1/23/89

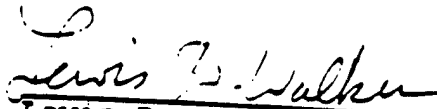

Lewis D. Walker
Deputy for Environment, Safety
and Occupational Health

IN WITNESS WHEREOF, I have hereunder set my hand as an authorized representative of Shell Oil Company.

Date: _____

R.G. Dillard
Vice President

XIII. GENERAL

A. Term: This MOU shall continue in effect as to a specific Scope of Work until the Army, pursuant to Subpart VI.E., accepts Shell's work pursuant to this MOU, and the reimbursement or payment has been made pursuant to Part IX.

B. Modification: Any provision of this MOU or of any Scope of Work may be modified at any time by both Parties' agreement. Any modification must: (1) be in writing; (2) show the date signed by the Parties; (3) specify that it is intended to modify this MOU; (4) state the provisions of the MOU to be modified; (5) state the new provisions; and (6) state when the new provisions are to be effective.

C. Effect of Execution: This MOU shall become effective on the later of its execution by the Parties or the entry of the Consent Decree. A Scope of Work shall become effective, final and binding upon its execution.

IN WITNESS WHEREOF, I have hereunder set my hand as an authorized representative of the United States Department of the Army.

Date: _____

Lewis D. Walker
Deputy for Environment, Safety
and Occupational Health

IN WITNESS WHEREOF, I have hereunder set my hand as an authorized representative of Shell Oil Company.

Date: 2/15/89

R.G. Dillard
R.G. Dillard
Vice President

SCOPE OF WORK

Shell will perform the following activities as lead party for design and implementation of the Rail Classification Yard/Motor Pool Area Interim Response Action:

1. Perform the preliminary investigation and engineering required to develop a Preliminary Engineering Design Package for review and approval by the Army.
2. Perform detailed design of the selected system, based on the agreed specifications, which will be in conformance with the selected alternatives set forth in the Final Decision Document including the following:
 - a. Extraction system consisting of wells in the alluvial underlying the Rail Classification Yard area.
 - b. Extraction system consisting of wells in the alluvium underlying the Motor Pool area.
 - c. Modification of the Irondale Boundary System extraction well system.
 - d. Injection system consisting of wells in the alluvium underlying the Irondale Boundary System area.
 - e. Addition of a metering station and building at the convergence of the Rail Classification Yard and Motor Pool Area extraction systems.
 - f. A conveyance system to transport extracted water from the extraction systems to the treatment

facility in the Irondale Containment System area; and a conveyance system to the new injection wells.

- g. Incorporation of a system in the Rail Classification Yard/Motor Pool Area transmission pipeline for shutdown of the extraction system during periods when the treatment plant's influent sump reaches a high level.
- h. Reconfiguration of existing sumps to provide for the existing process water decant sump to become an expansion of the existing influent sump.
- i. Addition of two submersible pumps to the enlarged influent sump to allow one of the pumps to supply the third carbon adsorber and the second pump to act as a stand-by for the three operational carbon adsorption systems.
- j. Reconfiguration of the existing pre- and post-carbon adsorber piping to allow for operation of all three adsorbers simultaneously.
- k. Addition of a pre- and post-bag-filtration system to the third carbon adsorber treatment system.
- l. Addition of a third bag guard-filtration unit, identical to the existing bag guard-filtration units, to treat the expanded capacity of the treatment system.
- m. Addition of a new process water decant sump to accommodate the water produced during start-up of three adsorber treatment systems.

- n. Addition of a new effluent water sump with pumps and controls to deliver water to the two separate recharge systems for the Irondale Boundary Containment System.
 - o. Alluvial monitoring wells in the vicinity of the new extraction and recharge systems.
3. Prepare the draft and final Implementation Document for review and approval by the Army and implement the final Rail Classification Yard/Motor Pool Area Implementation Document.
4. Perform all work required for the construction of the Rail Classification Yard/Motor Pool Area as described more fully in the Rail Classification Yard/Motor Pool Area Implementation Document (as defined below), including the following:
- a. Procure all required materials and subcontractors.
 - b. Provide supervisory and construction labor to manage subcontracts and install wells, piping and treatment systems, and required roads and utilities.
 - c. Test and supervise startup of the Rail Classification Yard/Motor Pool Area and the Irondale Containment System upon completion of construction.
 - d. Provide site cleanup and final grading of any disturbed areas in preparation for reseeding by the Army.

- e. All activities described in this paragraph 4 shall be performed in accordance with the construction work plan, basis of the estimated costs, schedule, technical specifications, engineering drawings, and health and safety plan to be set forth in the Rail Classification Yard/Motor Pool Area Implementation Document.
 - f. The term "Rail Classification Yard/Motor Pool Area Implementation Document" means the following documents, both of which are hereby incorporated herein by reference:
 - (1) Final Implementation Document for the IRA to extract groundwater from the Rail Classification Yard/Motor Pool Area; and treat and recharge that groundwater in the Irondale Containment System Area. This document is to be prepared by Morrison Knudsen (MK) for Shell and any amendments or modifications thereof and supplements thereto; and
 - (2) Prior to issuance of the documents described in 4.f.(1), but only prior to issuance of the documents, the Draft Implementation Documents for the IRA to extract groundwater from the Rail Classification Yard/Motor Pool Area, and treat and recharge groundwater in the Irondale shall be prepared by MK for Shell.
5. As set forth in the Final Decision Document, the Draft Implementation Document must be completed by August 25, 1990. To allow sufficient time for Army issuance by this milestone, Shell will submit forty (40) complete

copies of the Draft Implementation Document to the Army five (5) working days prior to the above deadline.

The Army will issue the Draft Implementation Document to the other Organizations, Department of Interior, and the State by August 25, 1990, and require comments within thirty (30) days of the date of issuance. Within five (5) working days after the end of the 30 day comments period, the Army will submit copies of all comments received to Shell for review and inclusion in the Final Implementation Document as appropriate.

Shell shall submit thirty (30) complete copies of the Final Implementation Document to the Army as a deliverable within twenty (20) working days of receipt of comments by Shell on the Draft Implementation Document. The Army shall issue the Final Implementation Document to the other Organizations, Department of Justice, and the State no later than five (5) working days after receipt from Shell.

6. During performance of construction of this Interim Response Action, Shell shall submit a monthly letter progress report to the Army summarizing work performed versus work planned, highlighting major items completed, and updating the schedule of construction until the Interim Response Action is completed. Monthly letter reports shall be submitted to the Army within ten (10) working days after the end of each monthly reporting period. At the close of the project,

a letter will be provided to the Army summarizing the work completed.

IN WITNESS WHEREOF, I have hereunder set my hand as an authorized representative of the United States Department of the Army.

Date 10/24/90

Deputy Program Manager

IN WITNESS WHEREOF, I have hereunder set my hand as an authorized representative of Shell Oil Company.

Date Oct. 17, 1990

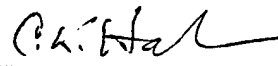
Manager, Denver Site Project

SECTION 3.0

RAIL CLASSIFICATION YARD/MOTOR POOL AREA IRA

CONSTRUCTION WORK PLAN

1. Survey: Area will be staked to locate and define the limits of excavation and location of facilities.

2. Soils Investigation: Prior to the beginning of the construction work the areas to be excavated will be investigated for contaminants as outlined in the Task Specific Health and Safety Plan. One hole every 1000 feet will be drilled to approximately one foot below planned excavations in the alignment of the pipeline and tested every five feet of depth by Health and Safety Personnel using field instrumentation. Should findings warrant further investigations, additional testwork will be specified and implemented.

3. Construction: Construction will be performed utilizing conventional methods established for the RMA. Any potentially contaminated soils will be drummed and handled per RMA Standard Operating Procedures (SOP).

To complete the Irondale Plant Modifications, the Plant will be shutdown for approximately four days. This will require that the reverse gradient in the recharge system be maximized prior to the shutdown to achieve an optimal gradient. Close coordination between the Plant Operation staff and the Construction Management personal will be maintained.

The transmission pipeline will require road crossings and railroad crossings which will interrupt traffic for several days at a time.

4. Dust Control: During the period when earth moving and excavation operations are in progress, a water truck will be on site and the surfaces will be sprayed to maintain the surface soil moisture content and control the evolution of dust.
5. Geological Services: An onsite geologist will monitor the construction work to review depth of wells and log information for future reference.
6. Health & Safety: A site Health and Safety Officer will monitor the work and test the excavations with an OVA and/or PID to ensure worker's safety and identify any volatile organic compounds that may be encountered.
7. Reporting: The Construction Manager shall prepare Daily Construction Reports to record field activities. Separately, a daily personnel log shall be used to record the names of all personnel who have visited the site.

As described in the IRA Scope of Work, a summary of IRA construction activities will be presented to the Army on a monthly basis.

8. Organization: An organization chart for the construction of the Rail Classification Yard/Motor Pool Area IRA is attached.

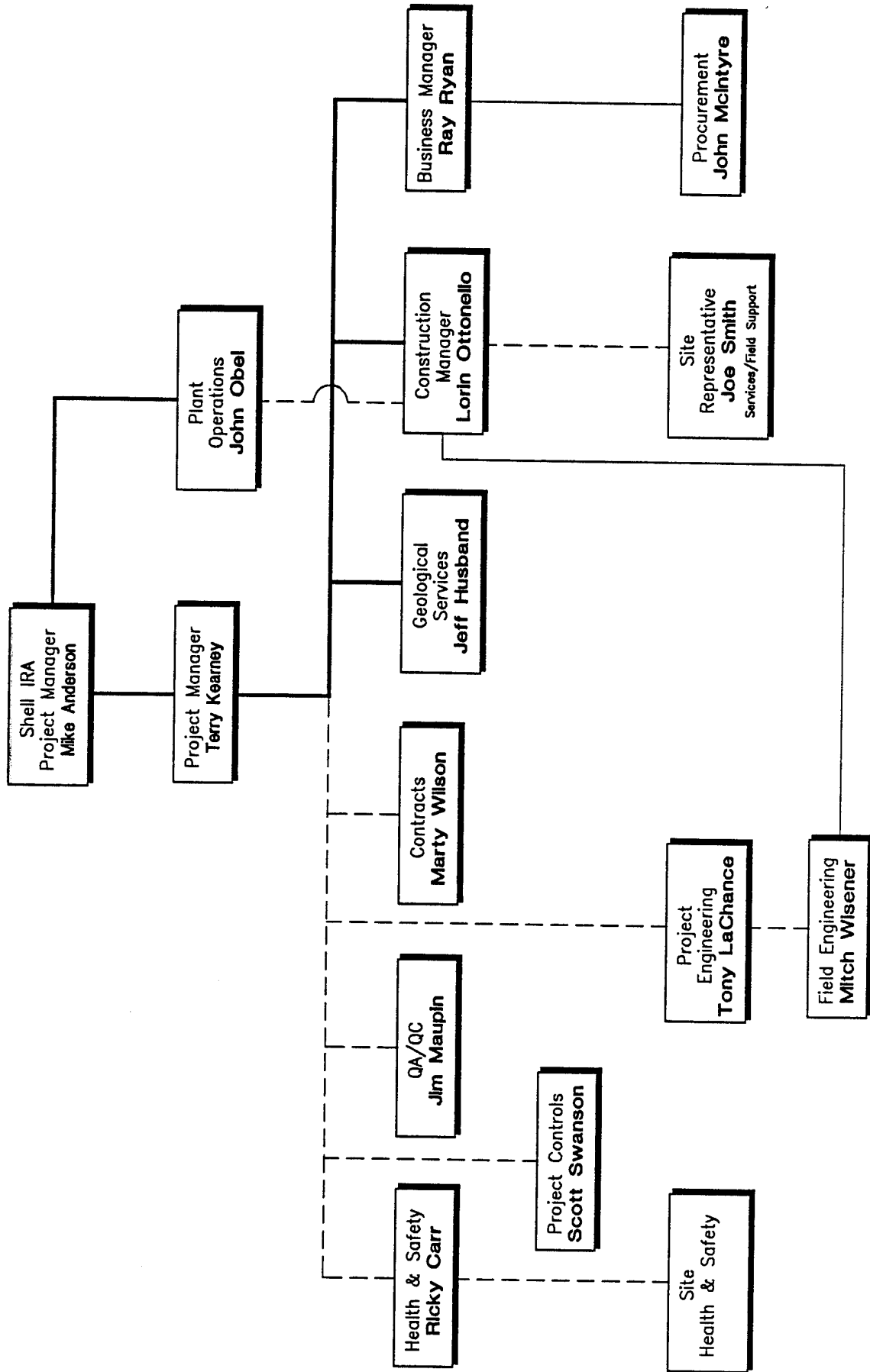

ORGANIZATION CHART
THE RAIL CLASSIFICATION YARD/
MOTOR POOL AREA IRA

SECTION 4.0

RAIL CLASSIFICATION YARD/MOTOR POOL AREA IRA

BASIS OF THE CONSTRUCTION COST ESTIMATE

The attached Construction Cost Estimate has been prepared for implementation of the Rail Classification Yard/Motor Pool Area Interim Response Action (IRA). Included in the estimated costs are the dewatering and monitoring wells, distribution piping, metering station and associated instrumentation. Also transmission pipeline, modifications to the existing Irondale Containment System, road work, and utilities as defined in the enclosed engineering specifications (Volume II), and the enclosed drawings (Volume III) are included in this estimate. The subject specifications and drawings were completed on January 11, 1991, and were subsequently issued in January 1991 as part of this Implementation Document.

Labor costs are based on the prevailing non-union wage rates in Adams County, Colorado. Equipment hourly rates are based on historical Morrison-Knudsen Corporation equipment operating costs. Prices for permanent materials and major equipment are based on verbal quotations and current estimating manuals.

Indirect costs for construction management, Contractor's overhead and fee, and the Health and Safety Program are also included in the estimate. The estimate has been prepared on the basis of Morrison-Knudsen Corporation acting as construction manager for Shell Oil Company and subcontracting all work.

For the development of health and safety supplies cost as well as labor productivity estimates, it was assumed that all work will be performed with Level C or D personnel protection as stated in the Task Specific Health and Safety Plan.

Labor costs for plant operation to support the construction effort are not included in this estimate.

Costs for drumming potentially contaminated materials has been included for well cuttings and well development only.

ESTIMATE BREAKDOWN

1.	Railyard Dewatering and Monitoring Wells	\$ 237,000
2.	Dewatering, Recharge and Monitoring Wells	207,000
3.	Distribution and Metering Station Piping	132,000
4.	Metering Station Foundation and Building	10,000
5.	Metering Station and Well Electrical	91,000
6.	Roadwork	107,000
7.	Transmission Pipeline	247,000
8.	Irondale Sump Modifications	65,000
9.	New Equipment in Irondale Plant	94,000
10.	Modifications to Irondale Plant Piping	58,000
11.	Irondale Distribution Piping Irondale System	85,000
12.	Irondale System Electrical	122,000
13.	Carbon for Plant Start-up	60,000
14.	Health and Safety	188,000
15.	Construction Management	339,000
16.	Contingency, Fee and Distributable Allocation	<u>458,000</u>
	Total	\$2,500,000

1.0 INTRODUCTION/SCOPE

This Task-Specific Health and Safety Plan (TSHSP) provides the basis for performing the Rail Classification Yard/Motor Pool Area Interim Response Action in a way that will control and minimize the risk to the health and safety of MK and subcontractor personnel. The plan defines the specific requirements and protocols for the protection of personnel performing the work.

Applicability of the TSHSP extends to all MK employees, subcontractors, and site visitors under MK's control. This work will be performed in accordance with the MK RMA Project Safety and Health Program, the RMA Site Safety and Health Plan, and all federal occupational health and safety rules and regulations.

This TSHSP will be reviewed by all MK and subcontractor personnel involved with the task prior to performing the work.

2.0 HAZARD ASSESSMENT

2.1 Chemical Hazards

Historical information indicates that the following chemical compounds have been detected in the groundwater in the area that the work will be performed.

<u>Chemical</u>	<u>TLV/PEL*</u>	<u>Skin Designation</u>
Chloroform	2 ppm	
1,2 - Dichloroethylene	200 ppm	
Benzene	1 ppm	x
Dibromochloropropane (DBCP)	1 ppb	x
Trichloroethylene (TCE)	50 ppm	

* The most restrictive value - TLV or PEL.

Chloroform, TCE, DBCP and Benzene are considered suspect or confirmed human carcinogens.

The concentrations of these chemicals in the groundwater pose a small potential exposure risk to personnel involved with activities that may involve contact with the groundwater. It is anticipated that the primary potential exposure risk is respiratory. Although a few of the detected compounds can be absorbed through the skin and mucous tissues, the detected concentrations are far below the levels generally associated with adverse effects. However, a potential cutaneous exposure risk may be present if previously undetected substances are present or known constituents are present in higher concentrations than previously detected.

Concentrations of volatile organic compounds may accumulate in confined spaces. Organic compounds may be further volatilized by disturbance of contaminated groundwater. Dispersion of the volatile organic compounds is anticipated to occur in the ambient air before reaching the breathing zone of personnel.

The symptoms of exposure to the chemicals known to be present in the groundwater are similar although the concentrations

which produce the symptoms may vary. Volatile organic materials produce odors particular to each compound, and the detection of any unusual odors should be considered an indication of potential exposure through inhalation. Medical symptoms produced generally depend upon the extent of exposure. Initial symptoms include irritation of the mucous membranes of the nose and throat, eye irritation, headache, nausea and dizziness. Long duration exposure to low concentrations, or acute exposures to high concentrations of contamination may produce weakness, vomiting, abdominal pain and central nervous system impairment (manifested by tremors, numbness in the limbs, lack of coordination, or unconsciousness). Long-term toxic effects are documented for many of the compounds although target organs and symptoms are varied and specific for each compound.

2.2 Physical Hazards

Physical hazards related to this task include personnel working with or in close proximity of heavy equipment, excavations, use of power tools, confined spaces, falling objects, and heat stress. Personnel need to be cognizant that the use of personal protective equipment may reduce dexterity and visibility and increase the difficulty of performing some tasks. Physical hazards may be controlled through the use of equipment guards, work practices, and training. Only equipment that is used for its intended task and that is in safe operating condition will be used. Personnel will be trained in the proper use and safe operation of the tools and equipment they utilize.

3.0 TRAINING

All personnel performing fieldwork for this task will have completed the forty (40) hour hazardous waste operations health and safety training pursuant to 29 CFR 1910.120(e) before beginning work. Eight (8) hour annual refresher training is required as necessary. The MK Construction Manager and subcontractor supervisors are required to have completed eight (8) hour Hazardous Waste Operations Supervisor/Manager training prior to the beginning of fieldwork.

Task/site specific training regarding the following topics will be given to all personnel performing fieldwork:

- Name of Site Safety and Health Supervisor and alternate.
- Safety and Health hazards related to this task.
- PPE requirements.
- Work practices.
- Hazard control.
- Medical surveillance requirements, including recognition of signs and symptoms which might indicate overexposure to chemical hazards.
- Decontamination procedures.
- Emergency response.
- Confined space entry procedure.

4.0 MEDICAL SURVEILLANCE

The basic requirements of the RMA Project Medical Surveillance Program shall apply to implementation of this task. No additional medical surveillance requirements are necessary.

5.0 PERSONAL PROTECTIVE EQUIPMENT (PPE)

The PPE to be utilized during Rail Classification Yard/Motor Pool Area IRA is dependent upon the specific task to be performed, the potential for contacting potentially contaminated soils or groundwater, and the concentration of air contaminants in the breathing zone of project personnel. The following PPE will be utilized (modified, as necessary, by the level of air contaminants measured in the breathing zone or at the discretion of the Site Health and Safety Officer).

<u>Task</u>	<u>PPE Level</u>
Well Drilling	Modified C
Trenching & Piping	D
Underground Electrical	D/Modified C
Metering Station Foundation and Erection	D
Transmission Pipeline	D
Sump Renovation including Excavation & Backfill	D/Modified C
Sump Tie-in	Modified C
Bag Filter Installation	D
Piping Revisions in Plant	D
Piping Tie-ins in plant	D/Modified C
Sump Pump installation	D/Modified C
Plant Electrical Installation	D
Plant Start up	D

5.1 Level D Personal Protective Equipment: ,

-
- PVC/Polyurethane steel-toed boots
 - Cotton Coveralls
 - Hard hats
 - Safety glasses with side shields
 - Gloves

5.2 Level C Modified Personal Protective Equipment:

- PVC/Polyurethane steel-toed boots
- Cotton Coveralls (inner)
- Poly-ethylene-coated Tyvek coveralls (outer)
- Hard hats
- Safety glasses with side shields
- Latex gloves (inner)
- Nitrile gloves (outer); Leather gloves may be worn outside of the nitrile gloves, but must remain on site at all times and be disposed of with other disposable clothing at the conclusion of the task.

5.3 Level C Personal Protective Equipment:

- PVC/Polyurethane steel-toed boots
- Cotton Coveralls (inner)

-
- Poly-ethylene-coated Tyvek coveralls (outer)
 - Hard hats
 - Latex gloves (inner)
 - Nitrile gloves (outer); Leather gloves may be worn outside of the nitrile gloves, but must remain on site at all times and be disposed of with other disposable clothing at the conclusion of the task.
 - Full-face air-purifying respirator with GMC-H cartridges (or equivalent).

6.0 SAMPLING/MONITORING

Sampling/monitoring will be performed to assess the exposure of personnel to hazardous materials and substances and to ensure that the proper level of personal protective equipment has been selected. Monitoring will also be conducted to delineate areas where protection is needed.

Air monitoring will be performed using direct-reading real-time instruments. Direct-reading instruments will be calibrated daily before use according to the manufacturer's instructions. The following table describes the appropriate response action for the detection of organic vapors. A flame-ionization detector (Foxboro Century OVA-128 or equivalent) will be used to monitor organic vapors. Monitoring will be performed periodically, as necessary.

Concentration in Breathing Zone*

Required Response

Less than 2 ppm

- 1) Level D or Modified Level C PPE.
- 2) Continue monitoring, as necessary.

Greater than 2 ppm,
Less than 20 ppm

- 1) Upgrade to Level C PPE
- 2) Increase frequency of monitoring.
- 3) Determine extent of airborne levels, modify extent of exclusion zones as necessary.

Greater than 20 ppm

- 1) Cease disturbing contaminated material, evacuate area.
- 2) Notify Construction Mgr. and H&S Mgr.
- 3) Determine extent of airborne levels, modify extent of exclusion zones as necessary.

* For five consecutive minutes; these levels are concentrations above background.

Air sampling using NIOSH or OSHA methodology will be performed at the discretion of the Site Health and Safety Officer.

7.0 SITE CONTROL

An exclusion zone will be established for each task where Level C-Modified PPE (or greater) is required. Entry into the exclusion zone is restricted to those personnel wearing the appropriate personal protective equipment. For the task of well drilling, the exclusion zone will be a minimum of 25 feet in all directions around the drill rig. The exclusion zone will be conspicuously demarcated through the use of orange traffic cones, or other equally suitable means. The Site Health and Safety Officer has at his/her discretion the authority to increase the size of the exclusion zone, if necessary, or to establish an exclusion zone for any of the other tasks.

IMPLEMENTATION DOCUMENT
FOR
RAIL CLASSIFICATION YARD/MOTOR POOL AREA IRA

VOLUME 2 SPECIFICATIONS

January 1991

Prepared by
Morrison Knudsen Corporation
Environmental Services Group
Denver, Colorado 80203

Prepared for
Shell Oil Company
Denver, Colorado 80203

The use of trade names in this report does not constitute an official endorsement or approval of the use of such commercial products. The report may not be cited for purposes of advertisement.

RAIL CLASSIFICATION YARD/MOTOR POOL AREA IRA
IMPLEMENTATION DOCUMENT
SPECIFICATION SCHEDULE
VOLUME 2

<u>Specification</u>	<u>Description</u>
1. 33-0705	Dampproofing
2. 33-0914	Field Painting
3. 33-1301	Pre-Engineered Metal Building
4. 34-0212	Site Preparation, Grading, Excavating and Backfilling
5. 34-0218	Asphaltic Concrete Pavement, Unpaved Service Road, and Railroad Crossing
6. 34-0270	Dewatering Wells
7. 34-0272	Alluvial Monitoring Wells
8. 34-0273	Reinjection Wells
9. 34-0301	Cast-in-Place Concrete
10. 34-0321	Concrete Reinforcement
11. 34-0325	Embedded Items
12. 34-0503	Miscellaneous Metals
13. 35-1501	General Specifications for Piping
14. 35-1510	Piping Insulation
15. 35-1511	Manholes
16. 36-0000	Equipment List
17. 36-0102	General Specifications for Equipment
18. 36-1823	Vertical Turbine Pumps
19. 36-1831	Submersible Well Pumps
20. 36-2614	Bag Filters
21. 37-1601	Electrical Work
22. 37-1608	Electrical Well Control Panel
23. 37-1651	13.8 KV Pole Line
24. 37-1655	Acceptance Testing Specification for Electrical Power Systems
25. 38-3750	Instrumentation Work
26. 38-3799	Instrument List and Data Sheets



SPECIFICATION 33-0705

DAMPPROOFING

CLIENT: SHELL OIL COMPANY

PROJECT: ROCKY MOUNTAIN ARSENAL REMEDIATION PROJECT

INTERIM RESPONSE ACTION FINAL DETAILED DESIGN

RAIL CLASSIFICATION YARD/MOTOR POOL AREA IRA

LOCATION: ROCKY MOUNTAIN ARSENAL, COMMERCE CITY, CO



CONTENTS

PAGE

1.	SCOPE	3
2.	RELATED WORK	3
3.	REFERENCE STANDARDS	3
4.	GENERAL PROCEDURES	4
5.	MATERIALS	5
6.	INSTALLATION	5
7.	PROTECTION	6
8.	BACKFILLING	6
9.	CLEANING	6



SPECIFICATION 33-0705

DAMPPROOFING

1. SCOPE

- A. This specification and other Contract Documents cover furnishing all material and equipment and providing dampproofing as required by applicable design drawings and as specified herein.
- B. Generally, required items of work include:
- 1) Application of dampproofing to exterior vertical surfaces of walls and base slab of pits, or other structures as required and indicated on drawings.
 - 2) Storage of material on jobsite, and protecting from weather and moisture until used.
 - 3) Removal of all unused materials and correction of spills and splashes.

2. RELATED WORK

- A. The following related work is covered in other specifications:
- 1) Site Preparation, Grading, Excavating and Backfilling (Specification 34-0212)
 - 2) Cast-In-Place Concrete (Specification 34-0301)

3. REFERENCE STANDARDS

- A. Organizations whose standards are referenced herein include the following:
- 1) ASTM - American Society for Testing and Materials
 - 2) NRCA - National Roofing Contractors Association Waterproofing Manual
- B. Any reference to standards of any society, institute, association or governmental agency shall be the edition in effect as of the date of this specification, unless stated otherwise.



4. GENERAL PROCEDURES

A. Delivery of Materials:

- 1) Materials delivered to construction site shall be in original container provided by the manufacturer.
- 2) Partially filled, broken or damaged units will not be acceptable.

B. Storage of Materials:

- 1) Materials delivered to construction site shall be stored in an area acceptable to the Field Engineer.
- 2) Storage of material shall be on skids or other units in such a way as to protect materials from water or other deteriorating elements.
- 3) Materials shall be covered and protected until ready for use.

C. Identification of Materials: Materials delivered to the construction site shall be plainly labeled and identified on the package with the manufacturer's name and material contents.

D. Environmental Conditions: Dampproofing materials shall not be applied when:

- 1) Air temperature is less than 35°F.
- 2) Relative humidity exceeds 90%
- 3) Immediately after a rain or during wet weather.
- 4) When water is formed on surfaces to be dampproofed.

E. Acceptance of Surfaces: Inspect, with the Field Engineer, surfaces to be dampproofed before commencing work.

- 1) Surfaces shall be clean, smooth and dry; and free of honeycombs, dirt, dust, frost, loose particles or other foreign matter which may interfere with proper installation of a functional system.
- 2) All pipes, vents, drains, weep holes, sleeves or other penetrations shall be ready to receive dampproofing at the surfaces involved.

F. Minor Surface Defects: Occasional defects such as shallow depressions, fins or other small projections



shall be corrected by the Contractor before application of damproofing materials.

- G. Samples of Materials: Samples of materials for inspection and testing shall be furnished by the Contractor in such size and quantity as may be required by the Field Engineer and/or testing laboratory.

5. MATERIALS

- A. All materials shall conform to standards of ASTM and other requirements specified herein. Use vertical grade materials for vertical surfaces (Quaker Seal and Coatings QSC-525, liquid applied waterproofing membrane or Engineer-approved equal.

1) Primer:

- a) Asphaltic type, conforming to ASTM C836-76, shall be used for damproofing below or above ground concrete and masonry surfaces.

2) Finish Coat for use in damproofing shall be as follows:

- a) Asphalt conforming to ASTM C836-76, Type A.

6. INSTALLATION

- A. General: Surfaces to be damproofed shall be cleaned of all oil, grease, dirt, dust and all other foreign materials. They shall be dry, reasonably smooth and free of sharp projections and depressions. Wire ties and other exposed steel shall be cut back a minimum of 1/4" from the surface, and the depression shall be filled with grout and struck smooth.
- B. Prime: Spray or brush surfaces with 2 coats of specified primer at the rate of one gallon per 100 sq.ft. Fill minor depressions with the specified materials as required for later adhesion of finish coat. Allow primer to dry overnight prior to application of finish coat.
- C. Finish Coat: On the well-primed surface, one application asphalt finish coat shall be applied by brush, using 1 gallon per 100 square feet.
- D. Terminations: Carry damproofing up to elevation required by drawings.



7. PROTECTION

- A. Care shall be taken to prevent discoloration of other parts of the structure not to be dampproofed, by the dripping or spreading of asphalt.

8. BACKFILLING

- A. Backfilling shall be performed under Specification 34-0212 of the project specifications.
- B. The dampproofing Contractor shall furnish an inspector to observe backfilling operations, and advise proper protection of dampproofing during backfilling.

9. CLEANING

- A. The Contractor shall be responsible for satisfactory removal of all pitch, asphalt or other material used in the work and/or splashed or spilled materials on other surfaces or on equipment. Surfaces so contaminated shall be repaired and refinished to the satisfaction of the Field Engineer without additional cost to the Owner. Contractor shall also remove all unused materials, containers and debris from construction site.



SPECIFICATION 33-0914

FIELD PAINTING

CLIENT: SHELL OIL COMPANY

PROJECT: ROCKY MOUNTAIN ARSENAL REMEDIATION PROJECT

INTERIM RESPONSE ACTION FINAL DETAILED DESIGN

RAIL CLASSIFICATION YARD/MOTOR POOL AREA IRA

LOCATION: ROCKY MOUNTAIN ARSENAL, COMMERCE CITY, CO



<u>CONTENTS</u>	<u>PAGE</u>
1. SCOPE	3
2. RELATED WORK	3
3. REFERENCE STANDARDS	4
4. GENERAL PROCEDURES AND WORKMANSHIP	4
5. PAINT MATERIALS	6
6. SURFACE PREPARATION	8
7. APPLICATION	9
8. PAINT MATERIALS SCHEDULE	11
9. COATING SYSTEMS SCHEDULE/BUILDINGS	12
10. COATING SYSTEMS SCHEDULE/EQUIPMENT	12



SPECIFICATION 33-0914

FIELD PAINTING

1. SCOPE

- A. This specification and other Contract Documents cover all field painting as required by the applicable drawings and as specified herein. Prepare, prime and paint all unfinished exposed paintable surfaces, both exterior and interior, except as otherwise noted under Paragraph 2, Related Work.
- B. Principal items of painting work include:
- 1) Touch-up of bare, abraded or otherwise damaged areas on previously primed surfaces including damage which has occurred since original touch-up was performed by others.
 - 2) Building elements such as modified structural members, floor grating, miscellaneous metals, and associated items.
 - 3) Utility items, both bare and insulated, such as piping, ductwork and conduit, including supports and accessories.
 - 4) Mechanical and process equipment. See Para. 10, Coating Systems Schedule/Equipment.
- C. Further description of certain items of painting is given in Para. 7C, Specific Application Requirements.

2. RELATED WORK

- A. The following related work is covered in other specifications:
- 1) Complete shop finish painting or coating of such items as exterior metal siding and accessories, electrical cubicles, cabinets, panels and motors; various items of mechanical and process equipment; control panels and instruments.
 - 2) Prime painting of such items as structural steel, non-galvanized miscellaneous metal; frames and appurtenances; various items of mechanical and process equipment.



B. The following shall not be painted:

- 1) Concrete and masonry
- 2) Concealed surfaces, except as specifically noted herein: those not generally visible within a room or area, or outdoors; hidden by other construction or finish, such as ceilings, furring or insulation; embedded in concrete or masonry.
- 3) Completely shop finished surfaces. See Para. 2A1.
- 4) Integrally finished materials: vinyl or neoprene gaskets and seals, weatherproof insulation jacket.
- 5) Nonferrous and corrosion resistant metals, unless otherwise noted herein: aluminum, stainless steel, copper, brass, bronze, chrome plating.
- 6) Bright metal and lubricated surfaces of equipment and piping.
- 7) Serial numbers, identification plates, I.D. numbers, etc.
- 8) Existing building elements that are not modified by this contract.

3. REFERENCE STANDARDS

- A. Organizations whose standards are referenced herein include the following:
- 1) OSHA - Occupational Safety and Health Administration
 - 2) SSPC - Steel Structures Painting Council
- B. Any reference to standards of any society, institute, association or governmental agency shall be the edition in effect as of the date of this specification, unless stated otherwise.

4. GENERAL PROCEDURES AND WORKMANSHIP

- A. Manufacturer's Directions given on container labels shall be followed. When they conflict with this specification, the more stringent requirements shall apply.
- B. Scheduling: In general, perform painting in each area after other work has been substantially completed. When directed, paint at times and in locations which will best expedite progress and completion of the project.



- C. Job and Weather Conditions: Do not paint when surfaces are wet or damp, under adverse weather conditions, when atmosphere is dusty, or during application or curing of plaster or cement. Apply paint when humidity is below 85% and when ambient temperature is between 70-90°F for varnish, 60-90°F for epoxy paint, and 50-90°F for other paint materials.
- D. Storing and Mixing Areas: Store materials and equipment, mix paints, and clean tools and equipment in assigned areas. Maintain these areas in clean orderly condition taking precaution to prevent fires. Keep paint at room temperature.
- E. Equipment and Tools:
- 1) Furnish scaffolding, ladders, staging and similar items in sufficient quantity to maintain satisfactory work progress. Place this equipment to avoid interference with work of others.
 - 2) Use appropriate tools for surface preparation and paint application. Maintain them in good condition. Thoroughly clean and dry brushes and other application tools at the end of each period of use and when changing to another paint material or color.
- F. Protection:
- 1) Provide and maintain suitable flame retardant covers to protect adjacent work, materials, machinery, piping, electrical work, name and rating plates, and unpainted and finish painted surfaces inside and outside the building from misapplication of paint and other damage. Protect sprinkler heads by means of plastic bags, when applicable. Post "wet paint" notices where appropriate. Remove protective covers when no longer needed.
 - 2) Provide and use ventilation equipment, respirators, protective masks and clothing, and other safety devices required for protection of personnel, as recommended by manufacturers or required by authorities.
- G. Detachable Items: Remove switch and receptacle plates, grilles, hardware, escutcheons and other finished items from final position before painting is started, and replace them upon completion of painting, all at the painting contractor's expense.



- H. Job Performance Standards: If so directed, a certain wall, room, area and item for each paint material and/or color will be selected as job standards to show acceptable finish, texture and workmanship.
- I. Inspection: Each coat of paint must be inspected and approved by the Field Engineer before application of succeeding coat. Give ample notification when a particular coat is ready for inspection. Recoat surfaces or otherwise correct deficiencies at own expense for any of the following circumstances:
- 1) Failure to have each coat inspected and approved.
 - 2) Dry film thickness less than the minimum recommended by the manufacturer.
 - 3) Work judged unacceptable by reason of defective surface condition not reported.
- J. Cleaning and Disposal:
- 1) During progress of this work, remove paint spots from floors, walls, equipment, finish hardware, nonferrous metals, glass and other unpainted or differently painted surfaces. Perform all work deemed necessary by the Field Engineer to completely restore finishes damaged by painting work, at no extra cost. Leave all surfaces in acceptable condition at final inspection.
 - 2) Remove surplus materials, containers, equipment and tools promptly when not needed. Collect oily rags and waste daily; destroy them or deposit them in tightly covered metal containers. Clean up and dispose of debris at close of each workday and upon completion in each area. Field Engineer is to identify disposal locations for Contractor's use.
- K. Guarantee work for the period required by Contract Documents against blistering, checking, alligating and other defects attributable to faulty surface preparation, materials, or workmanship. Promptly refinish areas exhibiting such defects within the guarantee period upon the Owner's notice and to his satisfaction.

5. PAINT MATERIALS

- A. Approved Manufacturers of paint materials which may be used on this project are listed below; no others will be considered unless some definite advantage to the Owner can be proven. Insofar as possible all paint materials shall be by one manufacturer.



Porter Coatings Div./Porter Paint Co.
 Valspar
 Sherwin-Williams Co.

- B. Paint Materials and Coating Systems Schedules herein list specific paint products which are considered suitable for the conditions of use. Painter will be permitted to use only the products specified, or comparable alternate products of these same manufacturers as determined by the Engineer. Alternate products shall be first line, high quality materials which are equal or superior in composition, durability and utility, to those scheduled.
- C. Painters Review: Painter shall be responsible for using compatible paint systems which are appropriate for intended service and method of application. If no paint system or material is scheduled for a surface or item required to be painted, painter shall submit his recommendation for approval by the Engineer. Before starting work, he shall submit a written statement that he has reviewed the drawings and specifications with an agent of the paint manufacturer, and that he either: (1) agrees with and will use specified products, or (2) suggests alternate products with reasons for recommended change. Show by copy of transmittal form that copy of statement has been transmitted to the paint manufacturer.
- D. Alternate Products shall be listed by product number and name, and referenced respectively to each scheduled paint material. Submit complete information on alternate products and proof of comparability. If no alternate list is submitted at time of bidding, the scheduled products must be used.
- E. Colors: A color schedule based on the products to be used will be furnished before finish painting work is started. The following table is intended to aid in estimating. If final color selection varies substantially from this and causes additional cost, a request for price extra will be considered.

Maximum Number of Colors

	<u>Walls</u>	<u>Ceiling</u>	<u>Trim</u>
--	--------------	----------------	-------------

Manufacturing and service areas	2	1	1
Personnel areas	1	1	1
Exterior	1	-	1
In any one area or room	1	1	1



Notes to Table

- 1) Colors will be selected from those available in the products to be used.
 - 2) No deep or decorator colors will be used.
 - 3) Interior exposed piping, ductwork and conduit will generally be painted the same color as the original element that is being modified.
 - 4) Colors for equipment as well as any safety code colors will be in addition to the numbers stated.
- F. Accessory Materials such as tints, linseed oil, shellac, putty, spackling compound, thinners and solvents shall be pure, of highest quality and as produced or recommended by paint manufacturer.
- G. Delivery and Labeling: Deliver materials to the site in original unopened containers bearing manufacturer's label stating name, volumetric description of major pigment and vehicle constituents, coverage rate and/or recommended film thickness, and application instructions.

6. SURFACE PREPARATION

- A. General: Thoroughly prepare surfaces before painting to assure smooth finish and proper paint adhesion. Remove dust, dirt, oil, grease, loose coatings, mortar, scale, rust and other foreign substances. Where paint remover is used, wash cleaned surfaces with solvent prior to painting. Use clean cloths and clean fluids to avoid leaving any residue film. Program cleaning and painting so dust or spray from the cleaning process does not fall on wet painted surfaces. Keep surfaces clean, dry and in suitable condition to receive the finish. Do not paint surfaces when moisture content of materials, as measured by an approved moisture meter, exceeds 12% for cementitious materials and plaster, and 15% for wood, unless otherwise permitted by the paint manufacturer.
- B. New Work Preparation:
- 1) Previously Primed Metal Surfaces: Wire brush field welds and damaged areas of primer down to bare bright metal, in accordance with SSPC-SP3. Touch up with specified primer to form a complete unbroken coating. Test for compatibility of previous primer and subsequent coats. If there is evidence of incompatibility such as lifting of previous primer, consult the paint manufacturer for recommendations. No extra cost will be allowed for corrective



measures such as additional intermediate coat or removal of previous primer.

- 2) Unprimed Carbon Steel: (Consists mainly of piping and miscellaneous supports.) Thoroughly wire brush to remove rust, loose mill scale, weld slag, etc, in accordance with SSPC-SP3. Wash clean with suitable solvent.
- 3) Galvanized Steel: Clean with solvent to remove foreign matter. Further special preparation is not necessary unless recommended by the paint manufacturer.
- 4) Nonferrous Metal: Remove oil deposits and contaminants by washing with xylol or mineral spirits. Rinse off soluble metal pretreatment with water.

7. APPLICATION

A. Mixing:

- 1) Use factory formulated and ready-mixed paint except 2-component materials. When necessary, thoroughly stir them (preferably by means of approved mechanical mixing machine), and then box before use. Do not work air into paint, reduce or alter except as recommended by the manufacturer.
- 2) Keep unused materials in tightly covered noncorrosive containers which are clean and free of residue and foreign matter. Remove surface film from materials in containers, and if necessary, strain before using. When containers are open and in use, stir paint periodically to avoid settlement and assure uniformity.
- 3) For 2-component materials, mix only the quantity which can be applied before pot life expiration, and carefully record the mixing time. Follow the manufacturer's mixing directions.

B. General Application Requirements:

- 1) Use skilled painters under competent supervision to apply material in strict accordance with the manufacturer's directions, including coverage rates and film thicknesses. Use brush, roller or spray, as applicable. Apply each coat in such manner as to produce an even film of uniform thickness, free from runs, sags, brush marks, visible paint laps or



"holidays." Completely coat crevices and corners, but avoid clogging lines and decorative features.

- 2) Prime bare ferrous metal within 24 hours after surface preparation. Before recoating gloss painted surfaces, dull them by light sanding or by using an approved proprietary product recommended for the purpose. Vary color of successive coats of same paint material by tinting to permit ready visual check of coverage. Tint undercoats close to shade of final coat. Allow each coat to completely dry before applying succeeding coat; at least 24 hours unless the manufacturer's recommendations permit less time. Do not apply varnish or enamel in direct sunlight.
- 3) Remove gratings before painting them and steel which supports them; replace gratings after final coat is dry. Paint access panels, primed hardware and items such as exposed pipe sleeves, ductwork and conduit. Make lines, letters and numbers, as well as edges of paint adjoining other materials or colors, straight and uniform.
- 4) For decorative painted items, where complete hiding of undercoats is not attained with the specified coating system, an additional finish coat shall be applied, if so directed. No extra cost for this will be allowed if the lack of hiding is due to poor application by the painter.

C. Specific Application Requirements:

- 1) Backpainting of Structural Steel: Apply one coat of scheduled finish paint on surfaces which will be inaccessible after siding, decking, sheet metal and other materials are installed.
- 2) Piping and Conduit required to be painted shall include such items as fittings, valves, strainers, traps, grilles, registers, outlets, hangers and supports. Nonferrous and corrosion resistant items which are exposed and adjacent to painted surfaces may also be painted when this is considered more practical than masking; they shall be painted when considered more appropriate for appearance; all with prior approval or direction by the Field Engineer. Painting shall conform to the following general scheme (except for color coded items, and as may be indicated on color schedule):

Above bottom of trusses - to match deck or framing



Against walls and columns - to match wall or column

- 3) Instrumentation: Pipe line instruments such as meters, thermometers, transmitters and control valves shall not be painted, except for surfaces which have been primed only. Protect them with suitable covering while painting piping.
- 4) Electrical Equipment: No further paint is required on finish painted electrical equipment, such as switchgear, transformers, bus duct, substations, motor control centers, panelboards, lighting fixtures and control panels. Supports and other items which have been prime painted only shall be finish painted.
- 5) Caulking, Sealing and Glazing Materials: In general, apply paint on oleoresinous type caulking and glazing compound where either or both adjacent surfaces are painted; omit where neither surface is painted. Avoid painting other sealing and glazing materials, except where this would be impracticable. Make sure any paint applied on these surfaces is compatible therewith.

8. PAIN T MATERIALS SCHEDULE

In the following schedule, specific paint products of approved manufacturers have been assigned an arbitrary Material Number which is used in Para. 9 and 10 to denote a type of material for each surface type.

Matl No.	Generic Description	Manufacturer's Numbers		
		Porter	Valspar	Sherwin-Williams
1	Primer, ferrous, structural	284	501	B50N5
2	Primer, ferrous, quick dry	297	91453	B50N2
3	Primer, galvanized metal	229	561	B50A1
4	Enamel undercoat	429	150	B49W2
5	Enamel, alkyd gloss, ext-int	24XX	36200XX	F65XX

NOTE: XX in the manufacturers' numbers denotes a series from which a specific color or product should be selected.



9. COATING SYSTEMS SCHEDULE/BUILDINGS

Surface:	Location or Item	Finish	Material Number		
			1st Coat	2nd Coat	3rd Coat

A. Primer Coats: Use these on various substrate surfaces where noted by *.

- 1) Shop primed steel 1 or 2 (touch-up)

* See 9A Primer Coats

Surface:	Location or Item	Finish	Material Number		
			1st Coat	2nd Coat	3rd Coat

- 2) Unprimed steel 1 or 2 - -
- 3) Galvanized metal, aluminum 3 - -

B. Interior/Exterior and Process

- 1) Pre-engr bldg steel frames, purlins, and girts Gloss alkyd enamel * 5 5
- 2) Other metal items/plat-forms, misc. metal, doors, windows Gloss alkyd enamel * 5 5

* See 9A Primer Coats

10. COATING SYSTEMS SCHEDULE/EQUIPMENT

A. Surface Condition Legend:

- | | |
|---------------------|----------------------------------|
| A1 Factory finished | B1 Shop primed steel |
| A2 Stainless steel | B2 Unprimed steel |
| A3 Aluminum | B3 Galvanized steel |
| A4 Copper or brass | B4 Gypsum board |
| A5 Plastic | |
| A6 Other | C2 Insulated/bright metal jacket |
| | C3 Insulated/plastic jacket |



B. Coating Systems/Exterior and Interior Equipment:

Surface	Finish	Material Number		
		1st Coat	2nd Coat	3rd Coat
1) Group A surfaces		No field painting required		
2) Group B surfaces				
B1	Gloss alkyd enamel	1 or 2 (touch-up)	5	--
B2	Gloss alkyd enamel	1 or 2	4	5
B3	Gloss alkyd enamel	3	5	--
B4	Gloss alkyd enamel	5	5	--
3) Group C surfaces				
C2 and C3		No field painting required		



SPECIFICATION 33-1301

PRE-ENGINEERED METAL BUILDING

CLIENT: SHELL OIL COMPANY

PROJECT: ROCKY MOUNTAIN ARSENAL REMEDIATION PROJECT

INTERIM RESPONSE ACTION FINAL DETAILED DESIGN

RAIL CLASSIFICATION YARD/MOTOR POOL AREA IRA

LOCATION: ROCKY MOUNTAIN ARSENAL, COMMERCE CITY, CO



	<u>CONTENTS</u>	<u>PAGE</u>
1.	SCOPE	3
2.	RELATED WORK	3
3.	REFERENCE STANDARDS	3
4.	GENERAL PROCEDURES	4
5.	DESIGN REQUIREMENTS	5
6.	BASIC MATERIALS AND FABRICATION	6
7.	ACCESSORIES	8
8.	SHOP PAINTING	9
9.	ERECTION	10



SPECIFICATION 33-1301

PRE-ENGINEERED METAL BUILDING

1. SCOPE

- A. This specification and other Contract Documents cover the design fabrication and erection of a pre-engineered metal building required by the applicable drawings and as specified herein.
- B. Items to be provided consist of the following:
- 1) Primary and secondary structural framing, including wall supports.
 - 2) Exterior metal, wall and roof covering, including trim, flashings, fasteners, weather sealing materials, and insulation where applicable
 - 3) Pipe penetration flashings
 - 4) Exterior hinged door and hardware

2. RELATED WORK

- A. The following related work is covered in other specifications:
- 1) Mechanical work: piping, plumbing, heating, ventilating and air conditioning, except items listed in Para. 1B (Series 36-1500 specifications)
 - 2) Electrical work: conduit, wiring, lighting, etc. (Specification 37-1601)
 - 3) Field painting (Specification 33-0914)
 - 4) Miscellaneous metals (specification 34-0503)

3. REFERENCE STANDARDS

- A. Organizations whose standards are referenced herein include the following:
- 1) AA - Aluminum Association
 - 2) AAMA - Architectural Aluminum Manufacturers Association
 - 3) AISI - American Iron and Steel Institute



- 4) AISC - American Institute of Steel Construction
- 5) ANSI - American National Standards Institute
- 6) ASTM - American Society for Testing and Materials
- 7) AWS - American Welding Society
- 8) FM - Factory Mutual
- 9) FS - Federal Specifications
- 10) MIL - Military Specifications
- 11) MBMA - Metal Building Manufacturers Association
- 12) SDI - Steel Door Institute
- 13) SSPC - Steel Structures Painting Council
- 14) SWI - Steel Window Institute
- 15) UL - Underwriters' Laboratories, Inc.

B. Any reference to standards of any society, institute, association or governmental agency shall be the edition in effect as of the date of this specification, unless stated otherwise.

4. GENERAL PROCEDURES

- A. Approval Plans: Shop drawings shall be submitted to the Design Engineer per contract requirements. Plans shall include dimensional roof plan, exterior wall elevations showing all materials (strengths) and openings, and one complete building section through each separate eave height of the building. The manufacturer shall indicate all components of the pre-engineered metal building modification system, building accessories, and the specific location of accessories in the metal building system.
- B. Certification: Submit a structural analysis and complete design calculations and drawings signed and sealed by a Professional Engineer who is registered in the state where the building will be erected, showing that building will withstand all design loads within the required safety factors.
- C. Guarantees: Furnish the following in a form acceptable to the Owner:



- 1) Materials and Workmanship: 5-year guarantee signed by the manufacturer and erector against defects in design, fabrication and erection, covering all building materials and appurtenances furnished. Guarantee shall include weather tightness.
 - 2) Color Finish: See Para. 8B hereafter for requirements.
- D. Record Drawings: Record prints shall be provided to the Design Engineer upon completion of the building. Plans shall include dimensional roof plan, exterior wall elevations showing all materials (strengths) and openings, and one complete building section through each separate eave height of the building. The manufacturer shall indicate all components of the pre-engineered metal building system, building accessories, and the specific location of accessories in the metal building system.

5. DESIGN REQUIREMENTS

- A. Type and Size: See drawings for frame type, bay size, plan dimensions, eave height, and roof slope.
- B. Design Criteria:
 - 1) Except as stated herein or noted on drawings, primary and secondary framing and covering of the building shall be designed for applicable loads and combinations of loads set forth in MBMA Recommended Design Practices Manual.
 - 2) Basic design criteria for various items shall conform to requirements of the following reference standards:
 - a) Structural Steel:

AISC - "Specifications for Design, Fabrication and Erection of Structural Steel for Buildings". "Code of Standard Practice for Steel Buildings and Bridges".
 - b) Cold-Formed Steel:

AISI - Specification for The Design of Cold-Formed Steel Structural Members.
 - c) Welding:

AWS - D1.1 Structural Welding Code



C. Design Loads: The basic design loads shall include snow, wind, and seismic, in addition to the dead load. All other design loads, whether they be of static or dynamic nature, shall be considered as auxiliary loads.

- 1) Snow Load: 30 psf
- 2) Wind Load: 30 psf
- 3) Seismic Loads: Zone 1
- 4) Auxiliary Loads:
 - a) Unit Heater
 - b) Lighting fixtures

6. BASIC MATERIALS AND FABRICATION

A. General: Use new materials throughout. Use U.S. manufactured materials only unless approved by the Engineer.

B. Structural Framing:

- 1) Materials shall have the following minimum yield strength; structural shapes and plates, 36,000 psi; structural tubing, 33,000 psi; cold formed structural members, 33,000 psi.
- 2) Fabrication: Perform in shop as much as possible for bolted or welded field assembly. Note on drawings any field cutting or drilling required. Steel shall be straight, true and within AISC tolerances. Make cold-formed sections by precision roll or brake forming to produce accurately dimensioned members, free of distortion. In the interest of obtaining satisfactory surface preparation and shop paint application, surfaces shall not contain fins, burrs, deep gouges, and other irregularities; sharp edges shall be reduced by grinding to 1/8" radius; and welds shall be made smooth, uniform, and free of projections, undercuts, overlaps, inclusions, and other detrimental defects.
- 3) Welding shall be performed in accordance with AWS Code, by welders and welding operators who have been previously qualified for the type of welding involved. Perform welding preferably in flat position, by shielded or submerged electric arc methods only. Avoid welding members while they are under stress. Make welds solid, homogenous, free



from pits and incorporated slag or scale, and of full area required to develop joint strength.

- 4) Bolting: Use high strength ASTM A325 or A490 type for primary framing connections; low carbon steel ASTM A307 type for secondary framing connections. The faying surfaces of all bolted connections shall be smooth and free from burrs or distortions. High strength bolted connections shall conform to AISC Specification for Structural Joints using ASTM A325 or A490 bolts.

C. Wall Covering:

- 1) Type for Walls: Exterior metal panel only using exposed fasteners, with insulation exposed on interior.
- 2) Panel Material: ASTM A446 structural quality hot-dip galvanized steel of appropriate grade, not lighter than 26 gauge, with G90 zinc coating designation. Panels shall have color finish specified herein under Shop Painting.
- 3) Panel Fabrication: Form accurately into ribbed panels of sufficient strength and stiffness, which interlock securely at side joints. Lapped joints are not acceptable. Provide in lengths as long as possible to minimize end joints.
- 4) Insulation: Mineral material of appropriate type and form, of density and thickness to provide U-factor not greater than 0.11 at walls, and labeled for UL or FM flame spread rating of 25 or less. Where exposed, insulation shall have a white vinyl vapor barrier facing of 6 mil minimum thickness and shall be fastened to building by mechanical fasteners or as recommended by the manufacturer.
- 5) Trim and Flashings: Factory formed from metal sheets of same type, thickness and finish as wall covering panel materials.
- 6) Fasteners:
 - a) Exterior Exposed Screws: Self-tapping or self-drilling type, of stainless steel, having metal-backed neoprene washers, with head color coated to match panels.
- 7) Sealing Materials: Polysulfide, butyl, neoprene, or other long-life high-performance weather-resistant type, in the form of compound, tape



gasketing, or closures, as applicable for each condition.

7. ACCESSORIES

A. Hinged Doors, Frames and Hardware:

- 1) Doors: Conform to SDI 100, except as otherwise noted; full flush design, 1-3/4" thick, 18 gauge galvanized/bonderized face sheets, bonded to kraft honeycomb core. Reinforce and prepare for hardware, and provide framed openings and stops for required glass. Door is to be prime painted in the shop. Apply color finish same as for wall panels. Color is to be selected from the manufacturer's standard colors.
- 2) Frames: Double rabbeted, either setup or knocked down type, of 16 gauge steel, reinforced and prepared for hardware and provided with rubber silencers. Frame is to be prime painted in the shop. Apply color finish same as for wall panels.
- 3) Hardware:
 - a) Hinges: Regular wright, template type, 4-1/2" x 4-1/2" size, 2-ball bearing, non-removable pin, of steel with either US2C cadmium coating or US2G zinc coating, bonderized and primed for painting. Provide 3 hinges per leaf.
 - b) Locksets: Heavy duty cylindrical type meeting FS FF-H-00106b, Series 161, having 0.070" minimum thickness knob to avoid denting, with US26D satin chrome plated finish. Provide ANSI A115 universal strike with box protector. Lock function and keying to be masterkeyed to the entry door. Keys shall be similar to the Irondale Treatment building to accept "Schlage" lock cylinders.
 - c) Closers: Overhead surface mounted parallel arm modern rectangular type, with rack and pinion construction, spring hydraulic operation, back-check feature, 105 degrees hold-open, adjustments for closing and latching speeds, and having aluminum lacquer finish.
 - d) Thresholds: Extruded aluminum, fluted design, 4" wide, 1/2" high.
 - e) Weatherstripping: A type consisting of compressible vinyl or neoprene with aluminum



retainer. Provide weatherstripping at perimeter of exterior door.

- B. Conduit Flashing: Provide rubber pipe flashing with aluminum base ring in sizes to match outside diameter of conduit as required. Caulk with sealing materials as specified herein.
- C. Pipe Flashings: "Dektite" E.P.D.M. rubber pipe flashings with aluminum base ring as manufactured by Buildex of Itasca, Illinois. Provide in sizes to match outside diameter of various pipe penetrations as required.

8. SHOP PAINTING

A. Primer for Framing Members:

- 1) General Requirements: Take special care to perform this work as specified herein and in the reference standards. Any steel delivered to the site on which the painting workmanship is judged defective will be rejected, and the Field Engineer will determine corrective measures to be taken.
- 2) Prime Paint Material: Synthetic rust inhibitive primer conforming to FS TT-P-664c, or a good quality primer which is certified as meeting or exceeding a recognized authoritative standard.
- 3) Cold Galvanizing Compound (Touch-up): Ready-mixed zinc-rich coating containing 95% metallic zinc by weight: Galvicon of Galvicon Corp.; ZRC of The Sealube Co.; or Galvanox Type I of Subox Coatings Div., BASF Wyandotte Corp.
- 4) Required Coatings of shop applied paint are as follows:
 - a) Surfaces and edges to be field welded, contact surfaces at high strength bolting, galvanized surfaces, surfaces to be encased in concrete, and machine finished surfaces - None
 - b) Surfaces inaccessible after assembly- 2 coats
 - c) All other surfaces - 1 coat
- 5) Surface Preparation: Remove loose mill scale and loose rust to the degree defined, and completely remove oil, grease and foreign matter, as required



by SSPC-SP2, Hand Tool Cleaning, and/or SSPC-SP3, Power Tool Cleaning.

- 6) Paint Application: When clean and dry, surfaces shall be painted in accordance with SSPC-PA1, Paint Application Specifications, and the paint manufacturer's recommendations. Apply specified prime paint by brush, spray or roller in a manner to cover entire surface smoothly, thoroughly and uniformly. Apply at proper coverage rate to provide average dry film thickness (dft) of 2 mils, except as otherwise required for special coating. Fabricator will be required to recoat any areas where the dft is less than this specified average.
 - 7) Unpainted Surfaces: Remove oil, grease, dirt and other foreign matter by cleaning with solvent and by brushing.
 - 8) Machined Surfaces: Protect from corrosion by applying an approved rust preventive coating such as Rust Veto 342 of E. F. Houghton & Co., Philadelphia, PA.
- B. Color Finish for wall, trim and flashing, and other items noted herein:
- 1) Surface Preparation: Clean thoroughly and apply zinc phosphate chemical conversion coating to assure maximum adhesion and weatherability.
 - 2) Paint: Baked-on system consisting of 0.2 mil dft prime coat and 0.8 mil dft top coat. Colors will be selected from the manufacturer's available standards.
 - a) Exterior: Silicone polymer type, guaranteed for 20 years against blistering, peeling, cracking, chipping and excessive chalking or fading.

9. ERECTION

- A. Assembly: Erect and assemble building components and appurtenances in accordance with approved shop drawings and the manufacturer's instructions and the proposed engineering plan as submitted and approved by the Field Engineer. Building shall be sealed and made weather-tight. Adjust doors and other items for satisfactory operation.
- B. Dissimilar Materials: Protect aluminum surfaces from direct contact with concrete, masonry, wood, or with



other dissimilar metal, by back-painting with a heavy brush coat of bituminous paint or by applying insulating tape.

- C. Touch-up abrasions in shop prime and finish painted surfaces using original coating materials. Use specified cold galvanizing compound for touch-up of welds and damaged areas of galvanized surfaces.

- D. Cleanup and remove debris periodically during erection and at final completion. Leave building neat and clean.



SPECIFICATION 34-0212

SITE PREPARATION, GRADING, EXCAVATING, AND BACKFILLING

CLIENT: SHELL OIL COMPANY

PROJECT: ROCKY MOUNTAIN ARSENAL REMEDIATION PROJECT

INTERIM RESPONSE ACTION FINAL DETAILED DESIGN

RAIL CLASSIFICATION YARD/MOTOR POOL AREA IRA

LOCATION: ROCKY MOUNTAIN ARSENAL, COMMERCE CITY, CO



<u>CONTENTS</u>	<u>PAGE</u>
1. SCOPE	3
2. RELATED WORK	3
3. REFERENCE STANDARDS	4
4. GENERAL PROCEDURES	4
5. SITE PREPARATION	5
6. EXCAVATING FOR STRUCTURES	6
7. EXISTING UNDERGROUND LINES AND SERVICES	8
8. MATERIAL STORAGE AND DISPOSAL	8
9. FILLING, BACKFILLING, AND COMPACTING	8
10. GRADING	11
11. INSPECTION	12
12. INCIDENTAL ITEMS	12



SPECIFICATION 34-0212

SITE PREPARATION, GRADING, EXCAVATING, AND BACKFILLING

1. SCOPE

A. This specification and other Contract Documents cover the furnishing of all equipment, labor, materials, and performance of work for site preparation, excavating, filling, backfilling, grading, and incidental items associated with earthwork and pipeline placement as required by applicable drawings and as specified herein.

B. Generally, required items of work include:

- 1) Clearing site
- 2) Stripping, cutting, and proofrolling
- 3) Excavating for structures and pipeline
- 4) Filling, backfilling, and compacting
- 5) Grading of site
- 6) Incidental items

2. RELATED WORK

A. The following related work is covered in other specifications:

- 1) Asphaltic Concrete Pavement, Unpaved Service Road, and Railroad Crossing (Specification 34-0218)
- 2) Manholes (Specification 35-1511)
- 3) Electrical Work (Specification 37-1601)
- 4) Cast-In-Place Concrete (Specification 34-0301)
- 5) General Specifications for Piping (Specification 35-1501)
- 4) Dewatering Wells (Specification 34-0270)



3. REFERENCE STANDARDS

A. Organizations whose standards are referenced herein are as follows:

- 1) AASHTO - American Association of State Highway and Transportation Officials
- 2) ANSI - American National Standards Institute
- 3) ASTM - American Society for Testing and Materials
- 4) ATF - Alcohol, Tobacco and Firearms Division of the U.S. Department of the Treasury
- 5) UBC - Uniform Building Code
- 6) Health and Safety Standard Operating Procedures
- 7) Colorado Standard Specification for Road and Bridge Construction
- 8) OSHA - Occupational Safety and Health Administration

B. Any reference to standards of any society, institute, association or governmental agency shall be the edition in effect as of the date of this specification, unless stated otherwise.

4. GENERAL PROCEDURES

A. Reference Points: Carefully maintain bench marks, monuments, and other reference points. Replace them as the Field Engineer directs if they are disturbed or destroyed.

B. Engineer: The services of a qualified Engineer will be provided to determine by observation and testing the quality of work and materials during earthwork operations. The Engineer will judge: adequacy of site preparation, excavating, suitability of bearing at excavated levels, acceptability of available fill material, and the correct placement and compaction of fill and backfill to specified densities. The Engineer will determine the frequency of testing. Stripping, cutting, excavating, filling, backfilling and compacting procedures require his approval as they are successively performed. Any work found unsatisfactory shall be



corrected at the Contractor's expense in an approved manner.

- C. Portions of the site may contain potentially contaminated materials (hazardous waste). In areas where contaminants are present or discovered, special procedures as specified by the Field Engineer shall be followed to protect personnel and avoid further contamination of the site or equipment. The only areas considered potentially contaminated are at the sewer crossings shown on the drawing.
- D. Excavation, removal, disposal or stockpiling of contaminated materials shall conform to the requirements of the construction work plan and approved by the Field Engineer. Contaminated soils will be designated by the Field Engineer. Potentially contaminated or contaminated soils will be stored as directed by the Field Engineer. If any contaminated or potentially contaminated soils must be removed from the site, they will be drummed by the Contractor in drums provided by the Field Engineer. The Field Engineer will be responsible for arranging for characterization, storage, and final disposal of drummed soils as required.

5. SITE PREPARATION

- A. Site Clearing: The Contractor shall accept the site in its existing condition; clear it of abandoned paving, foundations, roots, boulders, vegetation, rubbish, and other natural and artificial materials; and dispose of these materials onsite as the Field Engineer directs.
- B. Stripping: Remove topsoil and unsatisfactory surface material from portions of construction area where grades will be changed, to a minimum depth of 1'-0" unless shown otherwise on the drawings, or to greater depths as the Field Engineer considers advisable. Topsoil shall be stockpiled as directed by the Field Engineer for later use in post-construction revegetation work. Excavate soft spots encountered during stripping unless these spots occur in areas where deeper excavation will be required later for construction.
- C. Cutting: Perform cutting to required lines and grades as shown on the drawings or as indicated by the Field Engineer. Where unsuitable material is exposed at completion of planned cutting, overexcavate as directed by the Field Engineer until suitable bearing is reached. Remove rock encountered in proposed slab areas to an



elevation at least 6" below bottom of intended slab. If materials are removed below required elevations, through error or careless cutting, the Field Engineer will determine corrective measures to be made at the Contractor's expense.

6. EXCAVATING FOR STRUCTURES

- A. Dimensions: Excavate to required elevations and dimensions, allowing ample space for form and material placement, inspection, and form removal. If the nature of the soil permits and the Field Engineer gives prior approval, excavation for footings and grade beams may be made to correct dimensions and used as a concrete form. Degree of slope for open cut earth banks shall not exceed safe angle of repose of the soil in either dry or wet condition.
- B. Removing Materials: Excavate all materials encountered, except for existing services and permanent structures. Remove rock, boulders, portions of abandoned structures and other hard obstructions to at least 6" below planned excavation level. Soil conditions at bottom of excavation shall be subject to the Field Engineer's approval. Surfaces shall be clean and clear of mud or frozen material, and shall be maintained in good condition until concrete is placed.
- C. Suitable Bearing: Where unsuitable material is exposed at completion of planned excavation, overexcavate as directed by the Field Engineer until suitable bearing is reached. Place and compact fill as specified herein to correct elevations.
- D. Overexcavation: If materials are removed below required elevations, either by design or through error, the Field Engineer will determine necessary corrective measures to be made at the Contractor's expense.
- E. Rock Excavation:
- 1) Rock is defined as stone or hard shale in original ledge, and boulders over 1/2 cu.yd in volume or over 3'-0" in greatest dimension, which require special equipment and/or explosives to remove.
 - 2) It is assumed that materials at the job site can be excavated by hand labor or with normal equipment such as a power shovel or bulldozer. If rock is encountered, notify the Field Engineer for his



consideration before proceeding with further excavating.

- 3) If use of explosives is necessary, obtain the Field Engineer's written approval of procedure prior to beginning work. Work shall be performed by experienced licensed persons authorized to use explosives. Store, handle, and use explosives in accord with local, state, and/or federal regulations and ANSI A10.7.

F. Excavation for Pipeline:

- 1) Dimensions: Run trenches straight at required elevations and dimensions. Keep width of trench at pipe level to a minimum, allowing adequate space for laying pipe, constructing underground structures, and inspection. Where materials are removed below required elevations, place and compact fill as specified herein to correct elevations. The pipe shall be laid such that an air release valve (shown on the drawings) is located at each high point of the pipeline. If necessary, the pipeline depth shall be increased to avoid the need for additional air release valves. Bends shown on the plans can be made with bends in the pipe as long as such bends do not exceed the manufacturer's recommendations.
- 2) Removing Materials: Excavate all materials to a depth of at least 4" below the bottom of pipe and an additional 2" below bells and couplings. Soil conditions at bottom of excavation shall be subject to the Field Engineer's approval. Surfaces shall be clean, and clear of mud or frozen material. Maintain surfaces in good condition until pipe is laid and structures are built. Where excavating through paved roadways, asphalt shall be saw cut in straight lines parallel and to the limits of the excavation.
- 3) Excavating Under Foundations: Obtain the Field Engineer's approval before excavating under footings or other foundations, or within a 45 degree slope from horizontal plane at bottom of same. Stability of such foundations must be ensured by means directed by the Field Engineer.



7. EXISTING UNDERGROUND LINES AND SERVICES

- A. Locations of existing utilities shown on the drawings are approximate. It shall be the Contractor's responsibility to field verify actual locations. Carefully uncover, support, and protect. Do not cut, remove or damage these items without the Field Engineer's prior written approval; otherwise repair or replace them to the Field Engineer's satisfaction. Remove abandoned utilities as directed by the Field Engineer.

8. MATERIAL STORAGE AND DISPOSAL

- A. Select excavated materials which can be reused later; classify and stockpile each separately. Dispose of unsuitable and excess material and debris onsite as directed by the Field Engineer.

9. FILLING, BACKFILLING, AND COMPACTING

- A. Fill and Backfill Materials: Use Engineer-approved materials obtained from: stockpiles of excavated material, borrow areas, or off-site locations. Provide fill suitable for required compaction and free of: debris, organic material, rocks over 6", frozen matter, and excessive moisture or dryness.

- 1) Underbed for Slabs: Place 6" minimum of granular fill beneath slabs, using either gravel, sand and gravel mixture, or blast furnace slag, sized so that 100% will pass a 1" sieve and be retained on a No. 4 sieve. If shown on the drawings, underslab vapor barrier shall be as specified in Specification 34-0301, "CAST-IN-PLACE CONCRETE".
- 2) Fill Beneath Paved Areas: Use native material or clean granular earth consisting of sand and gravel, and containing only minor amounts of clay, silt or loam as directed and approved by the Field Engineer.
- 3) Backfill over Pipes and Utilities: Use clean native material which is free from rocks or debris within 12" of pipes and utilities.
- 4) All Other Fill and Backfill: Use clean native material which shall not contain rocks over 6" in size. Backfill next to foundations and top 12" of fill below topsoil shall not contain rocks over 4" in size.



- 5) Backfill Requiring Zero Slump: Where indicated on the drawings or the field engineer, backfill (flow-fill) meeting the following requirements will be used.

Ingredients

lb/cu.yd

Cement (0.45 sack)	42
Water (39 gallons)	325 (or as needed)
Coarse aggregate (Size No. 57)	1,700
Sand (ASTM C33)	1,845

- a) The maximum desired 28-day strength is 60 psi (not a specification requirement).
- b) The above combination of material or an approved equivalent may be used to obtain the desired flowable fill.

B. Placing Fill and Backfill:

- 1) After completing required stripping, cutting and/or excavating for structures and before placing fill and backfill material, scarify and thoroughly compact surfaces of existing soil in a manner causing minimum disturbance to underlying soil. Remove uncompacted material and replace it with proper fill.
- 2) Backfill excavations when installations have been completed, inspected and approved. Concrete shall have attained sufficient strength to withstand pressure of earth and compacting operation and be adequately shored as required prior to backfilling. Before proceeding, excavations shall be free of forms, debris and other foreign materials.
- 3) Deposit fill and backfill materials in horizontal layers of maximum 8" loose depth, and compact each layer. The Engineer may alter maximum depth of layer if, because of equipment, material, or other conditions, he deems it necessary to assure required degree of compaction. Under ramps, place fill in layers parallel to ramp slope. Do not place materials in water or on frozen subgrade. Avoid damage to installed work. Take special care to prevent wedging action or eccentric loading on structures.



C. Maximum Dry Density and Optimum Moisture Content:

- 1) For cohesive soils, maximum dry density and optimum moisture content shall be determined by one of the methods described in ASTM D-698, commonly known as the "Standard Proctor Test."
- 2) For cohesionless soils, relative density shall be determined by the methods described in ASTM D4253 and D4254.

D. Moisture Control: At the time of compacting areas where high density is required, fill material and the surface on which it is to be placed shall be within a range of 2% below to 2% above the optimum moisture content. Do not compact fill material until it has attained the required moisture content. Add an accurately determined and carefully measured amount of water to materials or surfaces which are too dry. Pile or spread out to dry, material which is too wet; if necessary, disk, harrow, or pulverize fill material.

E. Compacting:

- 1) General: Furnish satisfactory power-operated or power-driven hand operated equipment wherever possible to compact fill and backfill to requirements specified herein. Do not operate mobile equipment closer to foundation or retaining walls than a distance equal to height of fill above bottom of wall. If the fill or degree of compaction is unsatisfactory, make necessary adjustments until specifications are met. Material placed over layers not satisfactorily compacted shall be removed and the unsatisfactory areas recompacted.
- 2) Density for Cohesive Soils: For soils having 10% or more, by weight, of particles passing a No. 200 sieve, minimum required compaction densities at optimum moisture content and expressed as percentage of maximum dry density as measured by the Standard Proctor Test, shall be as follows:
 - a) Under Slabs, Pads, and Foundations: 95%
 - b) Under Paved Areas and Base Course: 95%
 - c) Over Pipes and Utilities: 80% (where pipes and utilities are located under slabs, pads,



foundations, railroads, and paved areas, 95% compaction density shall be provided)

- d) All Other Filled Areas: 88%
 - e) Waste Stockpile: None
 - f) Topsoil Stockpile: None
- 3) Density for Cohesionless Soils: For soils having less than 10% by weight, of particles passing a No. 200 sieve, minimum relative density shall be as follows:
- a) Under Slabs, Pads and Foundations: 70%
 - b) Under Paved Areas and Base Course: 70%
 - c) All Other Filled Areas: 70%
 - d) Waste Stockpile: None
 - e) Topsoil Stockpile: None

10. GRADING

- A. General: Perform necessary grading to achieve final elevations closely approximating those required by the drawings. Surfaces shall be well-compacted, reasonably smooth and free from irregularities, with uniform transitions made to adjacent areas. At completion and before acceptance of this work, clear away all equipment, barricades, surplus materials and rubbish. Regrade all disturbed areas to approximate natural grade or as directed by the Field Engineer. Leave the site in a neat, clean and presentable condition ready to accept seeding and mulching (by others).
- B. Ditches and Swales: Finish to drain readily. Take measures to prevent erosion of freshly graded areas by appropriate means until permanent drainage and erosion control facilities are installed. Repair and re-establish areas of settlement or erosion to required elevations and slopes prior to acceptance of the work.
- C. Subgrades: Form correct grades, crowns, cross-sections, and slopes required by drawings within a tolerance of \pm 0.1 ft. Fill and level depressions which might retain water and interfere with drainage.



11. INSPECTION

- A. All materials and each part or detail of the work shall be subject to inspection by the Field Engineer. The Field Engineer shall be provided access to all parts of the work and shall be furnished with such information and assistance by the Contractor as is required to make a complete and detailed inspection.
- B. The Field Engineer may direct the Contractor to remove or uncover portions of the work. After examination, the Contractor shall restore said portions of the work to the standard required by these specifications.
- C. The Contractor shall not proceed until the lines, grades and/or structure locations have been established. Any work performed by the Contractor contrary to the drawings, specifications or instructions of the Field Engineer, beyond the lines and grades shown on the drawings or any extra work done without authorization of the Field Engineer, may be ordered removed or replaced at the Contractor's expense.

12. INCIDENTAL ITEMS

- A. Safeguards: Provide, erect, maintain and later remove temporary safeguards such as barricades, guardrails and fences, signs, lights and flares for protection of personnel, the public, equipment and materials as the Field Engineer directs and as required by the RMA Facilities Engineer.
- B. Retaining Excavations: Provide shoring, sheeting, and bracing necessary to retain excavations, maintain banks securely, withstand water pressure, prevent cave-ins, and protect life and property. As backfilling proceeds, removing shoring, sheeting and bracing in a manner to prevent damage or disturbance to the construction and surrounding areas.
- C. Water Removal: Maintain grades to promote water drainage. Provide and operate equipment to keep construction areas free of subsurface, surface, and storm water. Provide necessary diversion ditches or other Engineer approved facilities for removing water. Dispose of water as directed by the Field Engineer so construction and storage areas, streets, roads, and other surfaces are not flooded.



SPECIFICATION 34-0218

ASPHALTIC CONCRETE PAVEMENT, UNPAVED SERVICE ROAD,
AND RAILROAD CROSSING

CLIENT: SHELL OIL COMPANY

PROJECT: ROCKY MOUNTAIN ARSENAL REMEDIATION PROJECT

INTERIM RESPONSE ACTION FINAL DETAILED DESIGN

RAIL CLASSIFICATION YARD/MOTOR POOL AREA IRA

LOCATION: ROCKY MOUNTAIN ARSENAL, COMMERCE CITY, CO



<u>CONTENTS</u>	<u>PAGE</u>
1. SCOPE	3
2. RELATED WORK	3
3. REFERENCE STANDARDS FOR ROAD WORK	4
4. GENERAL PROCEDURES FOR ROAD WORK	4
5. ASPHALTIC CONCRETE ROADWAY	6
6. UNPAVED ROADWAY (NEW)	6
7. RAILROAD CROSSING	7
8. TRANSITIONS	8
9. TESTING AND INSPECTIONS	8
10. CLEAN-UP	9



SPECIFICATION 34-0218

ASPHALTIC CONCRETE PAVEMENT, UNPAVED SERVICE ROAD,
AND RAILROAD CROSSING

1. SCOPE

- A. This specification and other Contract Documents cover all asphaltic concrete paving, unpaved service road construction and improvements, and railroad crossing work and appurtenances as required by applicable drawings and as specified herein.
- B. Generally, required items of work include:
- 1) Repair of existing paved roadway with asphaltic concrete pavement at crossing over B Street near the Motor Pool Area and at crossing over 7th Avenue near the intersection with B Street.
 - 2) Construction of unpaved service roads to access dewatering wells in the Railyard Area.
 - 3) Improvements to portions of existing unpaved roads in the Rail Classification Yard and Motor Pool areas.
 - 4) Repair of existing unpaved roadways at several pipeline crossings including "B" street near 8th Ave.
 - 5) Transitions to existing pavement.
 - 6) Construction of pipeline railroad crossings near both the Railyard and Motor Pool Area extraction wells and north of 7th Avenue near the intersection of 7th Avenue and B Street.
 - 7) Inspections and tests.
 - 8) Clean-up.

2. RELATED WORK

- A. The following related work is covered in other specifications:



- 1) Site Preparation, Grading, Excavating and Backfilling (Specification 34-0212)
- 2) Cast-In-Place Concrete (Specification 34-0301)

3. REFERENCE STANDARDS FOR ROAD WORK

A. Organizations whose standards are referenced herein include the following:

- 1) AASHTO - American Association of State Highway Transportation Officials
- 2) ASTM - American Society for Testing and Materials
- 3) The Asphalt Institute
- 4) Colorado State Department of Highways Construction and Material Specifications

B. Any reference to standards of any society, institute, association or governmental agency shall be the edition in effect as of the date of this specification, unless stated otherwise.

4. GENERAL PROCEDURES FOR ROAD WORK

A. Reference Points:

- 1) Carefully maintain bench marks, monuments and other reference points. Replace items as the Field Engineer directs if they are disturbed or destroyed.
- 2) Preserve principal base lines, bench marks, elevations, etc., as shown on drawings and established in the field. Set and maintain supplementary grades for use by equipment operators.

B. Highway Specifications: Work shall conform to referenced provisions of the State of Colorado Department of Highways, Construction and Material Specifications, except as otherwise specified herein. References therein to method of measurement and basis of payment do not apply.

C. Cooperation: Cooperate with all other Contractors requiring ingress and egress across portions of roads to



be constructed or repaired so that progress of the project, as a whole, is neither interrupted nor delayed.

- D. Protection: Provide, erect and maintain safeguards such as barricades, signs, flares and lights required by the RMA Facilities Engineer and as approved by the Field Engineer, for protection of public, personnel, equipment, structures, and materials. Remove safeguards when no longer needed and after approval for removal is given by the Field Engineer.
- E. Subgrade:
- 1) Completed subgrade cross sections and profiles shall conform to cross sections as shown on the drawings, unless otherwise directed by the Field Engineer.
 - 2) Soft spots, surface defects or other unsatisfactory conditions in the subgrade shall be corrected as required by adding more materials, regrading, compacting, removing and replacing certain areas, and other operations as applicable and as determined by the Field Engineer in conformance with Specification 34-0212.
- F. Sequence of Work:
- 1) Repair of existing roadways or new road construction shall not begin until other construction work on the site is essentially completed, or when directed by the Field Engineer.
 - 2) Confirmation of the Field Engineer on acceptability of subgrade shall be obtained before additional work is commenced.
 - 3) Placing of paving materials upon any portion of the subgrade will constitute acceptance of the subgrade as being proper and correct, and thereafter maintenance of design grades and construction of required thickness shall be the Contractor's responsibility.
 - 4) If subgrade, previously accepted, has been used temporarily as a construction road and requires restoration, the Contractor shall be responsible for this restoration.



5. ASPHALTIC CONCRETE ROADWAY

- A. Prime Coat: Section 407 of Colorado Standard Specifications for Road and Bridge Construction. Apply uniformly at the rate of 0.3 to 0.8 gallons per sq.yd to cover aggregates.
- B. Aggregate Base: Section 703.03 Class 4 or Class 5 of Colorado Standard Specifications for Road and Bridge Construction. Place and uniformly compact in one or more courses of compacted depth to the total thickness and cross section shown on drawings.
- C. Tack Coat: Section 407 of Colorado Standard Specifications for Road and Bridge Construction. Apply uniformly at the rate of 0.03 to 0.05 gallons per sq.yd. Tack coat may be required at the discretion of the Field Engineer over prime coat and between base and leveling or surface courses.
- D. Plant Mix Pavements: Section 401 of Colorado Standard Specifications for Road and Bridge Construction. The surface above the aggregate base material following the application of prime coat shall be the bituminous hot plant mix material (AC) grade "C" (Table 703-1) in minimum lifts of 1-1/2" and maximum lifts of 3 inches. The Contractor shall submit the following to the Field Engineer (see Section 401.02):
- 1) A proposed job-mix gradation which shall be wholly within the Master Range Table, Table 703-1, when the tolerances shown in Table 401-1 are applied.
 - 2) Source, approximate gradation, and percentage of each element used in producing the final mix.
 - 3) The name of the refinery which will supply the asphalt cement.
 - 4) A quantity of each aggregate, mineral filler, reclaimed material, and additive proposed for use which is sufficient for the required laboratory tests.

6. UNPAVED ROADWAY (NEW)

- A. Cover Coat Aggregate: Section 703.05 Type I of Colorado Standard Specifications for Road and Bridge Construction. Place and uniformly compact in one or more lifts to the total thickness shown on the drawings.



7. RAILROAD CROSSING

- A. General: All pipeline crossing railroads shall be in steel casings in accordance with the drawings. The construction of any railroad crossing shall not result in the railroad being out of service for more than a period of 96 consecutive hours without the prior approval of the Field Engineer. All railroad repair and/or reconstruction (including the track, track grade and gage, ties, spikes, spiking pattern, anchors, ballast, sub-ballast, grades, curvature, and dimensions, including expansion gaps in tracks, if any) shall be performed so as to match the quality, grades, and dimensions of the original construction. The work shall be conducted so as to disturb the minimum section of track practical for the required work. However, either boring and jacking a casing beneath the track, dismantling a section of the track, or excavating a trench beneath the track are acceptable methods of construction. Trackage shall be inspected and approved by the Field Engineer and an Army representative before operation of the track.
- B. Spikes: All track spikes utilized for track reconstruction shall be new and of a dimension and original quality of the spikes being replaced. Spikes shall be driven into spike holes drilled in the ties. When spikes are withdrawn, the hole shall be plugged with a standard treated tie plug.
- C. Ties: Any ties placed shall be spaced uniformly, and shall be installed in such a manner that there is a tie beneath any track joint. Ties shall be placed and maintained square to the line of rails on straight track and radially on curves. The use of picks to handle ties shall not be allowed. If deemed by the Field Engineer to be of acceptable quality, ties may be reused. If not, new ties matching the dimensions and quality of the original construction shall be used.
- D. Tracks, Toe Plate, Connectors: Undamaged track, toeplates, and connectors may be reused. Damaged materials shall be replaced with new material to match existing.
- E. Casing: Casing shall be installed as detailed on the drawings with even bearing throughout its length and shall slope to one end.



- F. Jacking and Boring Pits: If used, jacking and boring pits shall be a minimum of 30 feet from the centerline of track.
- G. Backfill: All backfill within or beneath the roadbed shall be compacted to 95 percent of Standard Proctor Density or of zero-slump fill as described in Specification 34-0212.
- H. Ballast: Any ballast removed shall be separated, salvaged and replaced to the original grades and dimensions.

8. TRANSITIONS

- A. Create all necessary transitions and warping to existing railroad tracks and paved or unpaved road surfaces, drains, and other installations, as may be required to complete the work.

9. TESTING AND INSPECTIONS

- A. Testing: The Field Engineer will employ an independent testing laboratory to perform testing and inspection services for the purpose of maintaining quality of construction. The extent of testing and inspection services will be determined by the Field Engineer.
- B. Contractors Responsibilities: Cooperate with the Field Engineer and laboratory to assure proper performance of all required testing and inspection services. Promptly deliver all material samples, furnish certification test reports as requested and other data when required by the referenced state highway and ASTM specifications, submit asphaltic concrete mix designs for approval, advise laboratory in advance of deliveries, furnish minor assistance in obtaining and handling field samples and provide necessary facilities at the site for sample and specimen storage.
- C. Testing Services: This work may include field inspection of equipment, materials, methods and results; testing and approval of materials; review of asphaltic concrete mix designs; field sampling and testing; etc., as determined by the Field Engineer. All testing and inspection shall be in accordance with the applicable state highway and/or ASTM specifications.



10. CLEAN-UP

- A. At completion and before acceptance of this work, clear away all equipment, barricades, surplus materials and rubbish, leaving site in a neat, presentable condition acceptable to the Field Engineer.



SPECIFICATION 34-0270

DEWATERING WELLS

CLIENT: SHELL OIL COMPANY

PROJECT: ROCKY MOUNTAIN ARSENAL REMEDIATION PROJECT

INTERIM RESPONSE ACTION FINAL DETAILED DESIGN

RAIL CLASSIFICATION YARD/MOTOR POOL AREA IRA

LOCATION: ROCKY MOUNTAIN ARSENAL, COMMERCE CITY, CO



	CONTENTS	PAGE
1.	SCOPE	3
2.	RELATED WORK	3
3.	REFERENCE STANDARDS	3
4.	CONTRACTOR QUALIFICATIONS	3
5.	DEWATERING WELL DESCRIPTION	4
6.	MATERIALS	4
8.	WELL CONSTRUCTION	7
9.	WELL DEVELOPMENT	9
10.	CLEANUP	10
11.	QUALITY CONTROL	10
12.	DISINFECTION	10



SPECIFICATION 34-0270

DEWATERING WELLS

1. SCOPE

A. The dewatering wells for the Rail Classification Yard (Railyard) groundwater interception system will be located in the alluvial aquifer in the west-central portion of Section 3, those for the Motor Pool Area groundwater interception system will be in the east-central portion of Section 4, and those for the Irondale Control System will be in the north-central portion of Section 33. The seven (7) dewatering wells composing the Railyard extraction system are expected to range in depth from 100-120 feet. The two (2) dewatering wells composing the Motor Pool extraction system are expected to range in depth from 90-110 feet. The four (4) extraction wells to be added to the Irondale Control System are expected to range in depth from 80-125 feet. The Contractor shall furnish equipment, labor, and materials, and perform operations as required to construct the dewatering wells, as shown on the drawings.

2. RELATED WORK

A. The following related work is covered in other specifications:

- 1) Cast-In-Place Concrete (Specification 34-0301)
- 2) Concrete Reinforcement (Specification 34-0321)
- 3) Site Preparation, Grading, Excavating and Backfilling (Specification 34-0212)
- 4) Submersible Well Pumps (Specification 36-1831)
- 5) Electrical Work (Specification 37-1601)

3. REFERENCE STANDARDS

A. The Organization whose standards are referenced herein is the American Petroleum Institute (API).

4. CONTRACTOR QUALIFICATIONS

A. The Contractor shall submit evidence to the Engineer, including drilling experience in the Denver area and a list of available drilling and support equipment, that they are competent to construct a dewatering well of the design provided by the Engineer. This evidence should ensure that the Contractor will have sufficient experienced personnel to construct the dewatering wells.



The Contractor shall supervise the well construction including borehole drilling; well construction; well development; installation of the pump, electrical components, pump column, holddown pipe, safety cable, recirculation system, pitless adaptor, and protective barricades; and final site grading.

5. DEWATERING WELL DESCRIPTION

- A. The dewatering wells shall be constructed within a 12-3/4 inch or larger diameter borehole to total depth. Material placed in the annulus includes a wellpack, bentonite seal, cement/bentonite grout seal, and a steel protective casing that is embedded in a reinforced concrete well pad. A pump column, holddown pipe, electrical components, safety cable, and discharge line and submersible pump will be installed. The Railyard and Motor Pool dewatering wells will also have a pitless adaptor and a recirculation system added to the pump discharge column. All wells will have a 12-inch carbon steel protective surface casing and surface completion as shown on the drawings.

6. MATERIALS

- A. Blank Casing: Blank casing for the Railyard and Motor Pool area wells shall be new 8-inch diameter, Schedule 80 PVC pipe, except for the uppermost 10 feet which shall consist of a single section of new 8-inch diameter Schedule 40 carbon steel coupled to the PVC casing. PVC joints shall be flush-threaded except for at the adapter to the steel pipe, which can be solvent welded.

Blank casing for the Irondale Control System wells shall be new 8-inch diameter, Schedule 40 PVC pipe with flush-threaded joints.

- B. Well Screen: Railyard and Motor Pool area dewatering wells shall be completed with new, 8-inch diameter, 40-slot (0.040 inch), flush-threaded, Schedule 80 PVC commercially slotted casing, with 8 rows of slots and 1/4-inch slot spacings.

Of Irondale Control System dewatering wells, ISEW41 and ISEW42 shall be completed with new, 8-inch diameter, continuous slotted PVC well screen with slot size of 60 to 70 slot (0.060 to 0.070 inch). Wells ISEW39 and ISEW40 shall be completed with new, 8-inch diameter



stainless steel well screen with slot size of 60 to 70 slot (0.060 to 0.070 inch).

- C. Tailpipe: The tailpipe shall be made of new, nominal 8-inch diameter, blank PVC pipe with a solid, one-piece bottom flush threaded cap or plug attached to the bottom of the tailpipe. Schedule 80 PVC shall be used for the Railyard and Motor Pool area wells, and Schedule 40 PVC shall be used for the Irondale Control System wells.
- D. Pitless Adaptor: The Railyard and Motor Pool area wells shall be equipped with a suitable commercially manufactured pitless adaptor (MAASS 8J3 or Engineer approved equal).
- E. Pump Column: Blank Schedule 80 PVC pipe of the diameter shown on the Drawings with threaded PVC couplings shall be used for the pump column; except for immediately above the pump in the Railyard and Motor Pool area, where a section of 3-inch diameter Schedule 40 stainless steel pipe shall be coupled to the PVC pipe as shown in the drawings.
- F. Holddown Pipe: Blank Schedule 80 PVC pipe of the diameter shown on the Drawings shall be used.
- G. Centralizers: Stainless steel or PVC with stainless steel hardware centralizers shall be used.
- H. Pump: A submersible stainless steel pump with check valve and PVC shroud (SDR 32.5) shall be installed in each dewatering well. In the Railyard and Motor Pool area wells the pump and shroud shall be nominal 4-inch diameter. In the Irondale Control System wells the pump and shroud shall be nominal 6-inch diameter.
- I. Well Pack: The well pack shall consist of washed silica sand as produced by Colorado Silica Sand or approved equal.

Well pack in the Railyard and Motor Pool area wells is expected to be graded size 8-12 mesh, but may be changed by the Field Engineer dependent upon subsurface geologic conditions encountered during borehole drillings.

Well pack gradation for the Irondale Control System wells shall be graded size 6-9 mesh.

- J. Bentonite: Bentonite used shall be sodium cation base montmorillonite, premium grade Wyoming-type bentonite,



which conforms to the most recent applicable API specifications. The Contractor shall furnish the Engineer with a certificate of compliance. Bentonite shall be protected from moisture during transit and storage.

- K. Water: A source of water for use during drilling operations will be identified by the Field Engineer. The Contractor is responsible for transporting water to each well site.
- L. Protective Casing: A nominal 12-inch diameter, carbon steel pipe shall be used for the surface protective casing. The steel casing shall penetrate 3 ft below the top of the concrete well pad in a minimum 18 inch boring and extend 2 ft above the pad in the case of the Railyard and Motor Pool area wells, and 3 ft above the pad in the case of the Irondale Control System Wells.
- M. Well Seal: The Railyard and Motor Pool area wells shall be provided with a lockable metal well seal for the protective casing (MAASS 12LCS custom made or approved equal). The well covers shall be supplied with a nominal 1-inch diameter, threaded access port welded to a Schedule 40 stainless steel nipple with stainless steel, threaded cap.
- The Irondale Control System wells shall be provided with a suitable well seal.
- N. Cement: Type II Portland cement shall be used for applications requiring cement.
- O. Recirculation System: The Railyard and Motor pool area wells shall have a recirculation system consisting of a nominal 3-inch by 1/2-inch thredolet, nominal 1/2-inch street elbow, nominal 1/2-inch nipple, and Dole Model GBSSGB-3.0 flow regulator. All components shall be stainless steel. The centerline of the thredolet shall be set approximately 4 ft above the top of the pump. The Irondale Control System wells shall not have a recirculation system.
- P. Protective Barricades: Protective barricades shall consist of nominal 4-inch diameter, Schedule 40 galvanized iron pipe; filled with concrete and painted yellow. Each barricade shall be set in concrete within a minimum 8-inch diameter borehole, and extend a minimum 3 ft below finish grade. Barricades shall be located as specified on the drawings.



- Q. Safety Cable: A safety cable consisting of 1/4-inch diameter 316 stainless steel shall extend from the top of the pump to a stainless steel cable eye welded to the inside of the steel protective casing below the well cover.
- R. Electrical Components: A pump power cable, level sensor cable, and level sensor connection shall be installed at each well.

7. EQUIPMENT

- A. Drilling of the dewatering wells shall be accomplished by use of a suitable well drilling rig. The drilling rig shall have the capabilities of successfully drilling and completing a nominal 8-inch diameter well within a 12-3/4 inch or larger diameter borehole to a depth of at least 130 ft. The Contractor shall have the capability of installing the required casing string, well pack, bentonite seal, cement/bentonite grout, centralizers, protective casing, and concrete well pad. The Contractor shall also be required to have the equipment necessary to install the holddown pipe, safety cable, electrical components, pump column, pump, pitless adaptor, recirculation system, and protective barricades as well as complete final surface grading.

8. WELL CONSTRUCTION

- A. General: The dewatering well shall be completed approximately as described in the following discussion. Site-specific geologic conditions may require changes to well construction plans. Modifications to construction specifications must be approved in advance in writing by the Engineer. Each activity must be completed to the satisfaction of the Field Engineer.
- B. Borehole: A minimum 12-3/4 inch diameter borehole shall be drilled to penetrate into the Denver Formation to the depths indicated on the drawings. Use of drilling methods requiring the use of drilling fluids (including water) to hold the borehole open will not be allowed in the Rail Yard or Motor Pool wells. Conventional rotary drilling, if used for the Irondale wells, will use water as drilling fluid. Natural polymer additives, such as Revert, may be used for the Irondale wells if necessary and approved by the Engineer. Sufficient penetration into the Denver Formation will be specified by the Field Engineer if local conditions differ from anticipated.



Sediment samples should be collected as directed by the Engineer to verify accurately the depth to Denver Formation. Both the Contractor and Field Engineer shall maintain accurate borehole and well construction logs for each well constructed.

- C. Well String: The well string, including the tailpipe, well screen, blank casing, pitless adaptor (where required), discharge pipe, and centralizers, shall be constructed as shown on the drawings. As also shown on the drawings, a hole of sufficient diameter to accommodate penetration of a 3/4-inch drain pipe shall be drilled through the blank casing in each of dewatering wells MPDW2, RYDW1, and RYDW6. The contact between the pipe and casing shall be grouted after the pipe is placed.
- D. Well Pack: The annulus between the well string and borehole wall shall be filled with washed silica sand from the total depth of the borehole to the depth above the well screen specified in the Drawings. Well pack shall be tremied into place. Precautions shall be taken during well pack installation to prevent excessive compaction. Prior to the placement of the top one (1) foot of well pack (which shall be graded size 16-40 mesh), the well shall be surged, and bailed or pumped to the satisfaction of the Engineer to promote settlement of the well pack. Additional well pack shall be added as required to maintain the well pack the required depth above the well screen. The Contractor shall place all water generated by bailing or pumping into suitable drums or tanks provided and disposed of by the Engineer.
- E. Annular Seal:
- 1) A 2 ft thickness of hydrated bentonite shall be placed on top of the well pack.
 - 2) A cement/bentonite grout shall be placed on top of hydrated bentonite extending from the bentonite seal to approximately 3 ft below finished grade. Grout shall be machine mixed to the satisfaction of the Engineer and shall consist of 20 parts cement to 1 part bentonite with a maximum of 6.5 gallons of water added per sack of cement.
 - 3) Well construction operations shall be conducted continuously from the beginning of well pack placement until the cement/bentonite slurry has been placed as stated above. Additional cement/bentonite



slurry shall be added as necessary to maintain the slurry level at the level shown on the drawings.

- F. Discharge String: The discharge string, including the pump, pump column, holddown pipe, recirculation system (where required), power cable, level sensor connection, water level sensors, and safety cable, shall be constructed as shown on the drawings.
- G. Surface Completion: The surface completion, including protective casing, well pad, protective barricades, and final surface grading shall be as shown on the drawings.
- H. Well Drill Cuttings: Well cuttings produced from the saturated zone during drilling operations shall be considered potentially contaminated. These cuttings shall be secured in 55-gallon steel drums provided by the Field Engineer. The Field Engineer will arrange for the ultimate disposal of well drill cuttings.
- I. Surveying: The elevation and location coordinates of the top of each well will be surveyed by the Field Engineer. For wells having a nipple in the cover that serves as a water-level measuring point, the top of the nipple shall be the point at which the coordinates are determined.

9. WELL DEVELOPMENT

- A. Each well shall be developed by the Contractor following completion of well construction activities. Well development shall be conducted by alternately surging, and bailing or pumping the well as directed by the Engineer, and shall include surging of all screened sections of the aquifer. Surging shall be performed by use of a surge block or bailer of minimum 6½-inch outside diameter. Wells shall be developed for a minimum of two hours, or until water discharged after surging of all screened well sections is essentially free of sand, whichever is greatest. Water removed from a well during development shall be visually monitored for sand content and turbidity. In any case, a minimum of five (5) times the estimated water contained within the borehole (assuming a porosity of the well pack of 0.3) shall be bailed and/or pumped from each well during well development. The total volume of water removed during well development shall be recorded by the Engineer. The Contractor shall place water generated during well development activities into suitable drums or tanks provided and disposed of by the Engineer.



10. CLEANUP

- A. At completion and before acceptance of this work, all equipment, surplus materials and rubbish shall be removed, leaving the site in a neat, presentable condition acceptable to the Field Engineer.

11. QUALITY CONTROL

- A. General: The Contractor shall maintain records as required by the Field Engineer to assure that well construction is being conducted within contract limits. The results of drilling construction and development activities shall be documented to assure they meet specifications. The Contractor shall maintain records of observations, measurements and test performed. These records shall be furnished to the Field Engineer no later than 24 hours after the tests, measurements, and/or observations are made.
- B. Well Construction Log: The Contractor and Field Engineer shall maintain logs of daily activities. A well construction log shall be maintained both by the Contractor and Field Engineer which shall also identify subsurface geologic occurrences encountered during well construction, and the depths to the water table and the Denver Formation.

12. DISINFECTION

- A. After the well has been properly developed, it shall be chlorinated. To accomplish this, the Contractor shall add calcium hypochlorite (65% available chlorine) or sodium hypochlorite solution to the well water such that the solution strength is between 50 and 200 ppm. Chlorination shall be accomplished through the entire depth of the well and the well shall stand for 8 hours minimum before the chlorinated water is removed to waste.
- B. The Contractor shall take all necessary precautions to prevent contamination of water from outside sources.



SPECIFICATION 34-0272

ALLUVIAL MONITORING WELLS

CLIENT: SHELL OIL COMPANY

PROJECT: ROCKY MOUNTAIN ARSENAL REMEDIATION PROJECT

INTERIM RESPONSE ACTION FINAL DETAILED DESIGN

RAIL CLASSIFICATION YARD/MOTOR POOL AREA IRA

LOCATION: ROCKY MOUNTAIN ARSENAL, COMMERCE CITY, CO



<u>CONTENTS</u>	<u>PAGE</u>
1. SCOPE	3
2. RELATED WORK	3
3. REFERENCE STANDARDS	3
4. CONTRACTOR QUALIFICATIONS	3
5. ALLUVIAL MONITORING WELL DESCRIPTION	3
6. MATERIALS	4
7. EQUIPMENT	4
8. WELL CONSTRUCTION	5
9. WELL DEVELOPMENT	6
10. CLEANUP	7
11. QUALITY CONTROL	7



SPECIFICATION 34-0272

ALLUVIAL MONITORING WELLS

1. SCOPE

A. Eight nominal 4-inch diameter alluvial monitoring wells will be constructed in the Rail Classification Yard/Motor Pool Area. The wells are expected to vary in depth from 90-120 ft. The Contractor shall furnish equipment, labor and materials, and perform operations as required to construct each well. Design details are presented on the drawings.

2. RELATED WORK

A. The following related work is covered in other specifications:

- 1) Cast-In-Place Concrete (Specification 34-0301)
- 2) Concrete Reinforcement (Specification 34-0321)

3. REFERENCE STANDARDS

A. The organization whose standards are referenced herein is the American Petroleum Institute (API).

4. CONTRACTOR QUALIFICATIONS

A. The Contractor shall submit evidence to the Engineer, including drilling experience in the Denver area and a list of available drilling and support equipment, that they are competent to construct a dewatering well of the design provided by the Engineer. This evidence should ensure that the Contractor will have sufficient experienced personnel to construct the monitoring wells. The Contractor shall supervise the well construction including borehole drilling, well construction, and well development.

5. ALLUVIAL MONITORING WELL DESCRIPTION

A. The monitoring wells shall be constructed within a minimum 10-inch diameter auger borehole (6 1/4-inch hollow-stem) to total depth. The well shall be completed with nominal 4-inch diameter Schedule 40 PVC slotted and blank casing, bottom plug, top cap, well pack, bentonite seal, cement/bentonite grout seal, and a vented lockable



well cap on nominal 8-inch diameter steel protective casing set in a reinforced concrete well pad.

6. MATERIALS

- A. Blank Casing: The well casing shall be new, nominal 4-inch diameter, flush-threaded, Schedule 40 PVC pipe with a vented, Schedule 40 PVC cap.
- B. Well Screen: The well shall be completed with new, nominal 4-inch diameter, flush-threaded, 20-slot (.020-inch) Schedule 40 PVC commercially slotted casing having slot spacers of 1/4"; and a solid, one-piece, flush-threaded Schedule 40 PVC bottom cap or plug.
- C. Well Pack: The well pack shall consist of graded size 10-20 mesh washed silica sand as produced by Colorado Silica Sand or approved equal. Well pack characteristics may be changed by the Field Engineer dependent upon subsurface geologic conditions encountered during borehole drilling.
- D. Bentonite: Bentonite used shall be sodium cation base montmorillonite, premium grade Wyoming-type bentonite, which conforms to the most recent applicable API specifications. The Contractor shall submit a certificate of compliance. Bentonite shall be protected from moisture during transit and storage.
- E. Water: A source of water for use during drilling operations will be identified by the Field Engineer. The Contractor is responsible for transporting water to each well site.
- F. Protective Casing: A nominal 5 ft. by 8-inch diameter carbon steel pipe shall be used for the surface protective casing. The steel casing shall penetrate 3 ft below the top of the well pad and extend 2 ft above the well pad. The steel casing shall have a metal, lockable cap (MAASS 8LCR or approved equal).
- G. Cement: Type II Portland cement shall be used for applications requiring cement.

7. EQUIPMENT

- A. Drilling of the alluvial wells shall be accomplished by use of a suitable hollow-stem auger or other well drilling rig not requiring drilling fluid for operation. The drilling rig shall have the capabilities of



successfully drilling a minimum 10-inch diameter borehole and constructing a nominal 4-inch diameter well to a depth of at least 120 ft. The Contractor shall have the capability of installing the required PVC casing string, well pack, bentonite seal, cement/bentonite grout, protective casing, and concrete well pad.

8. WELL CONSTRUCTION

- A. General: Alluvial monitoring wells shall be completed approximately as discussed in the following sections. Site-specific geologic conditions may require changes to well construction plans. Modifications to construction specifications must be approved in advance in writing by the Engineer. Each activity must be completed to the satisfaction of the Field Engineer.
- B. Borehole: A minimum 10-inch diameter borehole shall be drilled to penetrate approximately 1 ft into the Denver Formation. Sufficient depth into the Denver Formation will be verified by the Field Engineer.
- C. Well String: A well string consisting of nominal 4-inch diameter, 20-slot (0.020-inch) Schedule 40 PVC commercially slotted casing with bottom cap or plug, and nominal 4-inch diameter, blank, Schedule 40 PVC above the slotted casing shall be installed. The slotted casing shall extend from 2 to 7 feet above the water table encountered during drilling. The blank casing shall extend approximately 1.5 feet above the concrete well pad. All casing joints shall be flush threaded.
- D. Well Pack: A well pack shall consist of size 10-20 mesh washed silica sand extending to 5 ft above the top of the slotted casing from the total depth. Precautions shall be taken during well pack installation to prevent excessive compaction. Additional well pack shall be added as required to maintain the well pack approximately 5 ft above the top of the slotted casing.
- E. Annular Seal: A 2-ft thick hydrated bentonite seal shall be placed on top of the sand pack. A cement/bentonite grout shall be placed from the bentonite seal to 3 ft below finish grade. Well construction operations shall be conducted continuously from the beginning of sand pack placement until the cement/bentonite grout is placed. Additional cement/bentonite grout will be added as necessary to maintain the grout level at the desired level. The grout shall be machine mixed to the satisfaction of the Engineer and shall consist of 20



parts cement to 1 part bentonite with a maximum of 6.5 gallons of water added per sack of cement.

F. Surface Completion:

- 1) Protective Casing: A nominal 8-inch diameter steel pipe with a lockable cover and vented well cap, extending from 3 ft below finish grade to 2 ft above grade and painted yellow shall be installed.
- 2) Well Pad: A 48-inch square, 6-inch thick 6x6-W2xW2 WWF-reinforced concrete pad, centered on the well and sloped away from the well for drainage, extending into the borehole annulus to the top of the cement/bentonite grout shall be used (see Specifications 34-0301 and 34-0321).

G. Well Drill Cuttings: Well cuttings produced from the saturated zone during drilling operations shall be considered potentially contaminated. These cuttings shall be secured in 55-gallon steel drums provided by the Field Engineer. The Field Engineer will arrange for the ultimate disposal of well drill cuttings.

H. Surveying: The elevation and location coordinates of the top of the casing on the alluvial monitoring wells will be surveyed by the Field Engineer.

9. WELL DEVELOPMENT

A. The wells shall be developed by the Contractor following completion of well construction activities. Well development shall be conducted by alternately surging and bailing each well as directed by the Engineer, and shall include surging of all screened sections of the aquifer. Surging shall be performed by use of a surge block or bailer of minimum 3-inch outside diameter. Wells shall be developed for a minimum of two hours, or until discharge water during surging of all screened well sections are essentially free of sand, whichever is greater. Water removed from a well during development shall be visually monitored for sand content and turbidity. A minimum of 5 times the estimated water contained within the borehole (assuming a porosity of the well pack of 0.3) shall be bailed from each well during well development. The total volume of water removed during well development shall be recorded by the Field Engineer. Water generated during well development activities shall be collected in suitable drums or tanks provided and disposed of by the Field Engineer.



10. CLEANUP

- A. At completion and before acceptance of this work, all equipment, surplus materials and rubbish shall be removed, leaving the site in a neat, presentable condition acceptable to the Field Engineer.

11. QUALITY CONTROL

- A. General: The Contractor shall maintain records as required by the Field Engineer to assure that well construction is being conducted within contract limits. The results of drilling, well construction, and well development activities shall be documented to assure they meet specifications. The Contractor shall maintain records of observations, measurements and tests performed. These records shall be furnished to the Field Engineer no later than 24 hours after the tests, measurements, and/or observations are made.
- B. Well Construction Log: The Contractor and Field Engineer shall each maintain logs of daily activities. A well construction log shall be maintained by both the Field Engineer and Contractor and shall identify subsurface geologic occurrences encountered during well construction. The depths to the water table and the Denver Formation shall be identified.



SPECIFICATION 34-0273

REINJECTION WELLS

CLIENT: SHELL OIL COMPANY

PROJECT: ROCKY MOUNTAIN ARSENAL REMEDIATION PROJECT

INTERIM RESPONSE ACTION FINAL DETAILED DESIGN

RAIL CLASSIFICATION YARD/MOTOR POOL AREA IRA

LOCATION: ROCKY MOUNTAIN ARSENAL, COMMERCE CITY, CO



	CONTENTS	PAGE
1.	SCOPE	3
2.	RELATED WORK	3
3.	CONTRACTOR QUALIFICATIONS	3
4.	REINJECTION WELL DESCRIPTION	3
5.	MATERIALS	4
6.	EQUIPMENT	5
7.	WELL CONSTRUCTION	5
8.	WELL DEVELOPMENT	7
9.	CLEANUP	7
10.	QUALITY CONTROL	7
11.	DISINFECTION	8



SPECIFICATION 34-0273

REINJECTION WELLS

1. SCOPE

A. The reinjection wells to be added to the Irondale Control system will be located in the alluvial aquifer in the northwestern portion of Section 33. The ten (10) reinjection wells are expected to range in depth from approximately 55 to 115 feet. The contractor shall furnish equipment, labor, and materials, and perform operations as required to construct the recharge wells, as shown on the drawings.

2. RELATED WORK

A. The following related work is covered in other specifications:

- 1) Cast-In-Place Concrete (Specification 34-0301)
- 2) Concrete Reinforcement (Specification 34-0321)
- 3) Site Preparation, Grading, Excavating and Backfilling (Specification 34-0212)

3. CONTRACTOR QUALIFICATIONS

A. The Contractor shall submit evidence to the Engineer, including drilling experience in the Denver area and a list of available drilling and support equipment, that they are competent to construct a reinjection well of the design provided by the Engineer. This evidence should ensure that the Contractor will have sufficient experienced personnel to construct the reinjection wells. The Contractor shall supervise the well construction including borehole drilling; well construction; well development; holddown pipe, injection pipe, pitless adaptor, and protective barricades; and final site grading.

4. REINJECTION WELL DESCRIPTION

A. The reinjection wells shall be constructed within a 24-inch or larger diameter borehole to total depth. Material placed in the annulus includes a wellpack, bentonite seal, cement/bentonite grout seal, and a reinforced concrete well pad. A pitless adaptor, injection pipe, and holddown pipe will be installed. The recharge wells will be constructed with 12-inch diameter



Schedule 40 slotted and blank casing, and Schedule 40 carbon steel blank casing.

5. MATERIALS

- A. Blank Casing: The entire blank well casing except the uppermost 10 ft shall be new, nominal 12-inch diameter, Schedule 40 PVC pipe. The uppermost 10 ft shall consist of a single section of new, nominal 12-inch diameter, Schedule 40 carbon steel coupled to the PVC casing. PVC joints shall be solvent welded together.
- B. Well Screen: The well shall be completed with new, nominal 12-inch diameter, 60-slot (0.060 inch), solvent welded, Schedule 40 PVC commercially slotted casing; with 10 rows of slots and 1/4" slot spacers.
- C. Pitless Adaptor: A commercially manufactured pitless adaptor suitable for installation in the reinjection well shall be used (MAASS 6J2 or Engineer approved equal).
- D. Injection Pipe: Nominal 2-inch diameter, blank, Schedule 80 PVC pipe with threaded PVC couplings shall be used for the injection pipe.
- E. Holddown Pipe: Nominal 2-inch diameter, blank, Schedule 80 PVC pipe shall be used.
- F. Centralizers: Stainless steel or PVC with stainless steel hardware centralizers shall be used.
- G. Well Pack: The well pack shall consist of washed silica sand as produced by Colorado Silica Sand or approved equal. Well pack is expected to be graded size 6-9 mesh, but may be changed by the Field Engineer dependent upon subsurface geologic conditions encountered during borehole drilling.
- H. Bentonite: Bentonite used shall be sodium cation base montmorillonite, premium grade Wyoming-type bentonite, which conforms to the most recent applicable API specifications. The Contractor shall furnish the Engineer with a certificate of compliance. Bentonite shall be protected from moisture during transit and storage.
- I. Water: A source of water for use during drilling operations will be identified by the Field Engineer. The Contractor is responsible for transporting water to each well site.



- J. Well Cover: A lockable metal well cover shall be provided for the protective casing (MAASS 12LCS custom made or approved equal).
- K. Cement: Type II Portland cement shall be used for applications requiring cement.

6. EQUIPMENT

- A. Drilling of the reinjection wells shall be accomplished by use of a suitable well drilling rig. The drilling rig shall have the capabilities of successfully drilling and completing a nominal 12-inch diameter well within a 18 inch or larger diameter borehole to a depth of at least 120 ft. The Contractor shall have the capability of installing the required casing string, well pack, bentonite seal, cement/bentonite grout, centralizers, and concrete well pad. The Contractor shall also be required to have the equipment necessary to install the holddown pipe, pitless adaptor, and injection pipe, as well as complete final surface grading.

7. WELL CONSTRUCTION

- A. General: The recharge well shall be completed approximately as described in the following discussion. Site-specific geologic conditions may require changes to well construction plans. Modifications to construction specifications must be approved in advance in writing by the Engineer. Each activity must be completed to the satisfaction of the Field Engineer.
- B. Borehole: A minimum 18-inch diameter borehole shall be drilled to penetrate into the Denver Formation as indicated on the drawings. Use of drilling methods requiring the use of drilling fluids (including water) to hold the borehole open will not be allowed. Sediment samples should be collected as directed by the Engineer to verify accurately the depth to Denver Formation. Both the Contractor and Field Engineer shall maintain accurate borehole and well construction logs for each well constructed.
- C. Well String: The well string, including the well screen, blank casing, pitless adaptor, and centralizers, shall be constructed as shown on the Drawings.
- D. Well Pack: The annulus between the well string and borehole wall shall be filled with washed silica sand



from the total depth of the borehole to the depth above the well screen specified on the Drawings. Well pack shall be tremied into place. Prior to placement of the top one (1) foot of well pack (which shall be graded size 16-40 mesh), the well shall be surged, and bailed or pumped to the satisfaction of the Engineer to promote settlement of the well pack. Additional well pack shall be added as required to maintain the well pack the required depth above the well screen. The Contractor shall place all water generated by bailing or pumping into suitable drums or tanks provided and disposed of by the Engineer.

E. Annular Seal:

- 1) A 2 ft thickness of hydrated bentonite shall be placed on top of the well pack.
- 2) A cement/bentonite grout shall be placed on top of hydrated bentonite extending from the bentonite seal to approximately 3 ft below finished grade. Grout shall be machine mixed to the satisfaction of the Engineer and shall consist of 20 parts cement to 1 part bentonite with a maximum of 6.5 gallons of water added per sack of cement.
- 3) Well construction operations shall be conducted continuously from the beginning of well pack placement until the cement/bentonite slurry has been placed as stated above. Additional cement/bentonite slurry shall be added as necessary to maintain the slurry level at the level shown on the drawings.

F. Injection String: The injection string, including the injection pipe and holddown pipe shall be constructed as shown on the Drawings.

G. Surface Completion: The surface completion, including well pad, and final surface grading shall be as shown on the Drawings.

H. Well Drill Cuttings: Well cuttings produced from the saturated zone during drilling operations shall be considered potentially contaminated. These cuttings shall be secured in 55-gallon steel drums provided by the Field Engineer. The Field Engineer will arrange for the ultimate disposal of well drill cuttings.



- I. Surveying: The elevation and location coordinates of the top of the 12-inch casing of each reinjection well will be surveyed by the Field Engineer.

8. WELL DEVELOPMENT

- A. Each well shall be developed by the Contractor following completion of well construction activities. Well development shall be conducted by alternately surging and bailing or pumping the well as directed by the Engineer, and shall include surging of all screened sections of the aquifer. Surging shall be performed by use of a surge block or bailer of minimum 10-1/2-inch outside diameter. Wells shall be developed for a minimum of two hours, or until discharged water after surging of all screened well sections is essentially free of sand, whichever is greatest. Water removed from a well during development shall be visually monitored for sand content and turbidity. In any case, a minimum of five (5) times the estimated water contained within the borehole (assuming a porosity of the well pack of 0.3) shall be bailed and/or pumped from each well during well development. The total volume of water removed during well development shall be recorded by the Engineer. The Contractor shall place water generated during well development activities into suitable drums or tanks provided and disposed of by the Engineer.

9. CLEANUP

- A. At completion and before acceptance of this work, all equipment, surplus materials and rubbish shall be removed, leaving the site in a neat, presentable condition acceptable to the Field Engineer.

10. QUALITY CONTROL

- A. General: The Contractor shall maintain records as required by the Field Engineer to assure that well construction is being conducted within contract limits. The results of drilling construction and development activities shall be documented to assure they meet specifications. The Contractor shall maintain records of observations, measurements and test performed. These records shall be furnished to the Field Engineer no later than 24 hours after the tests, measurements, and/or observations are made.
- B. Well Construction Log: The Contractor and Field Engineer shall maintain logs of daily activities. A well



construction log shall be maintained both by the Contractor and Field Engineer which shall also identify subsurface geologic occurrences encountered during well construction, and the depths to the water table and the Denver Formation.

11. DISINFECTION

- A. After the well has been properly developed, it shall be chlorinated. To accomplish this, the Contractor shall add calcium hypochlorite (65% available chlorine) or sodium hypochlorite solution to the well water such that the solution strength is between 50 and 200 ppm. Chlorination shall be accomplished through the entire depth of the well and the well shall stand for 8 hours minimum before the chlorinated water is removed to waste.
- B. The Contractor shall take all necessary precautions to prevent contamination of water from outside sources.



SPECIFICATION 34-0301

CAST-IN-PLACE CONCRETE

CLIENT: SHELL OIL COMPANY

PROJECT: ROCKY MOUNTAIN ARSENAL REMEDIATION PROJECT

INTERIM RESPONSE ACTION FINAL DETAILED DESIGN

RAIL CLASSIFICATION YARD/MOTOR POOL AREA IRA

LOCATION: ROCKY MOUNTAIN ARSENAL, COMMERCE CITY, CO



CONTENTS

PAGE

PART I - GENERAL

1.	SCOPE	4
2.	RELATED WORK	4
3.	REFERENCE STANDARDS	5
4.	GENERAL	6

PART II - MATERIALS AND CONSTRUCTION

1.	GENERAL	6
2.	MATERIALS	6
3.	PROPORTIONING	10
4.	FORMWORK	12
5.	FABRICATING AND PLACING REINFORCEMENT	12
6.	JOINTS AND EMBEDDED ITEMS	13
7.	PRODUCTION OF CONCRETE	13
8.	PLACING	14
9.	REPAIR OF SURFACE DEFECTS	14
10.	FINISHING OF FORMED SURFACES	14
11.	SLABS	14
12.	CURING AND PROTECTION	15
13.	TESTING	16
14.	EVALUATION OF CONCRETE STRENGTH	17
15.	ACCEPTANCE OF STRUCTURE	17
16.	GROUTING	17



SPECIFICATION 34-0301

CAST-IN-PLACE CONCRETE

PART I - GENERAL

1. SCOPE

- A. This specification, the reference standard noted herein (namely ACI 301, Revised 1981, as described in Para. 3), and other Contract Documents cover all cast-in-place concrete and associated work, as required by the applicable drawings and as specified herein.
- B. Generally, required items of work include:
- 1) Cast-in-place items, including but not limited to the following as applicable: foundations, footings, grade beams, walls, pits, equipment foundations and pads, slabs on grade and grouting column bases.
 - 2) Embedment of items, furnished under other specifications.
 - 3) Form materials and related items.
 - 4) Treatments and finishes.
 - 5) Curing materials.
 - 6) Miscellaneous items.

2. RELATED WORK

- A. The following related work is covered in other specifications:
- 1) Concrete Reinforcement (Specification 34-0321)
 - 2) Site Preparation, Grading, Excavation and Backfilling (Specification 34-0212)
 - 3) Embedded Items for embedment under this specification (Specification 34-0325).



3. REFERENCE STANDARDS

- A. To be complete, this specification requires the use of American Concrete Institute Standard ACI 301 (latest edition), "Specifications for Structural Concrete for Buildings." This project specification 34-0301 is intended to supplement and modify ACI 301, and will take precedence where conflict exists.
- B. Requirements of ACI 301 shall govern the work, except as noted herein. For convenience, paragraphs herein are numbered and titled the same as Chapters in ACI 301. Contractor shall keep available in the project field office, at least 1 copy of ACI 301.
- C. Except as noted herein, concrete work shall conform, in general, to recommended practice contained in related references given in Section 1.5 of ACI 301.
- D. For standards referred to in ACI 301, the edition and supplements in use and currently available at date of this specification 34-0301 shall apply.
- E. Organizations whose standards are referenced herein or in ACI 301, include the following:
 - 1) ACI - American Concrete Institute
 - 2) ASTM - American Society for Testing and Materials
 - 3) AWS - American Welding Society
 - 4) CE - Corps of Engineers
 - 5) USDC-CS - U.S. Dept. of Commerce Commercial Standard
 - 6) USNBYD - U.S. Navy Bureau of Yards and Docks (now called Shore Facilities Systems Command)
 - 7) CRSI - Concrete Reinforcing Steel Institute
 - 8) UBC - Uniform Building Code
 - 9) NBS - National Bureau of Standards
- F. Any reference to standards of any society, institute, association or governmental agency which is part of the Building Code listed above shall be the edition date



published in the referenced Building Code. Any reference to standards which is not part of the Building Code listed shall be the edition in effect as of the date of this specification, unless stated otherwise.

4. GENERAL

- A. Samples: Submit to the Field Engineer, or directly to designated testing laboratory (see Para. 16 herein), samples of such materials associated with this work as he may request, for visual examination and testing. Obtain approval of samples before installation. Materials used in the work shall conform to approved samples and shall be obtained from same sources, unless otherwise approved by the Field Engineer.
- B. Certification: Submit test reports and other acceptable evidence that materials furnished comply with specified requirements.

PART II - MATERIALS AND CONSTRUCTION

1. GENERAL (Chapter 1, ACI 301)

- A. Requirements of ACI 301 shall govern the work, except as noted herein. For convenience, main paragraphs herein under Part II, are numbered and titled the same as Chapters in ACI 301.

2. MATERIALS (Chapter 2, ACI 301)

A. General:

- 1) For convenience, all materials required in the work are listed under this paragraph, and arranged by major categories. Where applicable, reference is made to material requirements given in ACI 301.
- 2) Use manufactured materials in accordance with the manufacturer's recommendations if such recommendations differ from requirements specified herein, call to the Field Engineer's attention before proceeding. Generally, the more stringent requirements shall apply.



B. Basic Materials:

- 1) Portland Cement: (See ACI 301, Section 2.1) For all concrete use ASTM C150, Type II low-alkali. Type III cement may be used where high early strength is required with written approval of the Engineer. When such properties as air-entrainment, water reduction and higher plasticity are required, they shall be obtained preferably by using admixtures. For exposed concrete, use the same brand of cement throughout.
- 2) Admixtures: (See ACI 301, Section 2.2.) Following are the only admixture materials which will be permitted in concrete, under conditions specified in Para. 3C herein.
 - a) Air-Entraining (A-E) Admixture: ASTM C260, containing no chlorides.
 - b) Water Reducing Admixture: ASTM C494, Type A. When required by climatic and other job conditions at time of placement, use (1) Type D water reducing and retarding, or (2) Type E water reducing and accelerating.
 - c) Fly Ash: Pozzolan Class F, ASTM C618.
 - d) Calcium Chloride: ASTM D98. Any use of calcium chloride must be approved in writing by the Engineer.
 - e) Pumping Aid: Where included by testing laboratory in design mix to assist in pumping concrete, use a water soluble lubricant that will decrease friction in the pipeline and increase flow without interfering with the hydration of cement or the compressive strength of the concrete. Use Darex Pumping Aid as manufactured by Construction Products Division of W. R. Grace Co., or Engineer approved equal.
- 3) Water: As per ACI 301, Section 2.3.
- 4) Aggregates: (See ACI 301, Section 2.4.) Where aggregates for normal weight concrete conforming strictly to ASTM C33 are not available, local aggregates with minor variations from C33 requirements will be considered, provided evidence of satisfactory performance by tests and actual



service is submitted. Fineness modulus (defined in ASTM C125) for aggregates placed in flatwork shall have a range of 2.3 to 3.1. For special floor finish aggregates, see Para. 2E herein.

C. Reinforcement and Accessories: Furnished under Specification 34-0321.

D. Form Materials and Related Items: (See ACI 301, Chapter 4.)

- 1) Forms: Wood, steel or other Engineer approved material based on safety and quality of finished work.
- 2) Form Ties: For exposed work, use approved types so arranged that when forms are removed, no metal will be closer than 1" from any surface. Wire ties may be used where concrete will not be exposed to weather and where discoloration would not be objectionable.
- 3) Compressible Form Material: A 1" thick material which is sufficiently rigid to support concrete in smooth plane when placed, and capable of being compressed under force of building expansion (see Para. 4C herein). Acceptable material is Styrofoam FR Form Liner of Dow Chemical Co., or Engineer approved equal.
- 4) Expansion/Isolation Joint Materials:
 - a) Premolded Joint Filler: (See ACI 301, Section 6.2) For use in expansion or isolation joints, size 1/2" thick x full depth of slab, less 1/2". Nonextruding and resilient bituminous type, ASTM D1751, either cane fiber or granulated cork.
 - b) Foam Joint Backer Rod: 1/2" diameter closed cell rod, Sonafoam as manufactured by Sonneborn Division of Con Tech, Inc., or Engineer approved equal.
 - c) Joint Sealant:
 - (1) For ambient temperatures 70°F or above, use Gardox Joint Sealing Compound as manufactured by W. R. Meadows, Inc., or Engineer approved equal.



(2) For ambient temperatures 50°F to 70°F, use Cold Applied R/A Joint Seal as manufactured by W. R. Meadows, Inc., or Engineer approved equal.

5) Waterstop: (See ACI 301, Section 6.3.)

- a) Size 6" x 3/16", either ribbed or dumbbell shape, with or without center bulb, plain or split, of either (a) rubber conforming to Corps of Engineers Specification CRD-C513, or (b) vinyl per CRD-C572. Use manufactured Els, tees and crosses to form continuous waterstop at joints and corners of containment areas.
- b) Where waterstop is shown at locations where new concrete construction abuts existing concrete work, use Volclay RX-101 bentonite/butyl-rubber type waterstop as manufactured by Volclay Corp. or Engineer-approved equal.

E. Treatments and Finishes: (See ACI 301, Chapter 11, and Para. 11 herein for uses of these materials.)

- 1) Abrasive Aggregate: Composed of not less than 60% pure aluminum oxide, bonded by a vitreous ceramic material, and graded from 1/32" to 1/4" size.

F. Curing Materials: (See ACI 301, Section 12.1, and Para. 12 herein.)

- 1) Curing Compound: Liquid membrane-forming type (sodium silicate type not approved) meeting all requirements of ASTM C309, Type 1 clear or translucent, having a fugitive dye to facilitate visual check of coverage. Use of Type 2 white pigmented type is recommended during hot weather. Instructions on containers of compound delivered to the job shall clearly state the maximum coverage rate which meets ASTM C309 moisture retention requirement (0.055 gram/sq.cm/72 hr). A curing compound which performs additional functions (hardening, dustproofing, etc.) may be used provided it meets ASTM C309 completely and performs the primary function of curing.



- 2) Waterproof Sheet Materials: Any of the types listed in and meeting requirements of ASTM C171: waterproof paper, 4 mil (0.004") polyethylene film, white burlap-polyethylene sheet.
- 3) Sealing Materials for laps in waterproof covering: pressure sensitive tape, nonstaining mastic, or other effective adhesive recommended by covering manufacturer.
- 4) Finishing Aid: Sprayable material designed to form a monomolecular film on fresh plastic concrete, and to retard moisture evaporation prior to finishing; such as Confilm of Master Builders Co.

G. Miscellaneous Items:

- 1) Nonshrink Grout: (See Section 19A and 19B herein.) Ready-to-use metallic aggregate type, manufactured under rigid quality control to produce a flowable material without drying shrinkage or settlement, free of excessive bleeding, and having increased strength at all ages as compared to a plain grout mix. Approved products are: Embecco 885 Grout manufactured by Master Builders Co., Cleveland, or Engineer approved equal. Use in accordance with the manufacturer's recommendations.

3. PROPORTIONING (as per ACI 301, Chapter 3, except as noted.)

A. Mix Requirements: The design mix for the concrete shall be the standard "house" design of a local, reputable ready-mix plant. It shall have been proved on previous projects to produce concrete of a compressive strength at 28 days equal to the strength indicated in these specifications or on the drawings. The mix design shall contain a minimum of 5 1/2 sacks of cement per cubic yard for 1 1/2 inch maximum sized aggregate.

B. Mix Requirements: Conform to following:

- 1) Floor Slab Concrete: Minimum 4000 psi compressive strength at 28 days, 517 lbs/cu.yd of concrete minimum cement content for 3/4" maximum size aggregate, slump range 3" to 5", entrained air range 1½% to 2½% by volume.
- 2) Structural/Framing Concrete: Minimum 4000 psi compressive strength at 28 days, 540 lbs/cu.yd of concrete minimum cement content, for 3/4" maximum



size aggregate, slump range 3" to 5", entrained air range 0% to 3% by volume.

- 3) All Other and Exterior Concrete: Minimum 4000 psi compressive strength at 28 days, 540 lbs/cu.yd of concrete minimum cement content, for 3/4" maximum size aggregate, slump range 2" to 4", entrained air range 4% to 6% by volume.
- 4) For Pumped Concrete: Where concrete is to be pumped, the slumps indicated above are to be measured at the point of deposit, the outlet end of pump hose. As a preliminary measure of slump, tests made at the hopper on the pump may use the following as a guide to provide for loss in the pipeline:

<u>Additional Slump Allowable, Inches</u>	<u>Length of Pipeline Feet</u>
0	0-49
+ 1/4	50-99
+ 1/2	100-149
+ 3/4	150-199

C. Air Entrainment:

- 1) Concrete "subject to destructive exposure" (as noted in ACI 301, Section 3.4) shall be defined as exposed horizontal surfaces outdoors or in unheated areas where freezing and thawing are likely to occur.
- 2) Concrete for floor slabs and other traffic surfaces shall contain 1-1/2 to 2-1/2% entrained air.

D. Use of Admixtures: Only the admixtures specified herein under Materials will be permitted in concrete. Mix designs shall take into account all admixtures required or proposed for use. When more than one type is used, they shall be of same manufacturer wherever possible, to assure compatibility.

- 1) Use air-entraining admixture, not air-entraining cement, to obtain and control required air content.
- 2) Water reducing admixtures shall be used in concrete for all floor slabs and other traffic areas, and may be used in other concrete.
- 3) Fly ash not exceeding 30 lbs/bag of cement will be permitted in concrete to promote workability and



plasticity, subject to approval of design mix and satisfactory tests.

- 4) Do not use calcium chloride in concrete which has metal items (other than reinforcement and anchor bolts) such as conduit, piping, door frames, and any aluminum or galvanized steel, embedded, built-in, or permanently in contact with the concrete.

E. Mix Designs: The Contractor shall be responsible for determining mix designs, as per ACI 301, Section 3.8.2.2, Method 2, or Section 3.8.2.1, Method 1, for normal weight concrete; or Section 3.8.3 for lightweight concrete. Mix designs and supporting data shall be submitted to the Engineer for approval before placing concrete.

4. FORMWORK (as per ACI 301, Chapter 4, except as noted.)

A. Excavated Surfaces cut to correct dimensions may be used to form footings and grade beams, if nature of the soil permits and the Field Engineer gives prior approval.

B. Form Design and Construction: Make forms accurately conforming to required line, grade and shape, and sufficiently tied and braced to maintain proper position and dimensions during concrete placing. Arrange forms and supports so they may be readily removed without hammering or prying against concrete. Obtain the Field Engineer's approval of completed formwork before placing concrete.

C. Installing Compressible Form Material: This material as specified herein is required where new concrete is placed adjacent to existing foundation or building wall. Before placing concrete, embed boards of the material firmly in spots of adhesive applied on existing construction.

D. Form and Shore Removal from load supporting concrete structures will not be permitted until 7-day test cylinders have been broken and results provide a basis for predicting when concrete will attain sufficient strength to support expected loading. In each case, the Engineer will determine what strength is sufficient, but in general 75% of required 28-day strength shall be considered adequate.

5. FABRICATING AND PLACING REINFORCEMENT See Specification 34-0321.



-
6. JOINTS AND EMBEDDED ITEMS (As per ACI 301, Chapter 6, except as noted. See also Section 11.2 therein.)
- A. Control Joints shall be provided accurately and neatly in floor slabs at locations shown on drawings by one of the following methods:
- 1) Permanent Insert: Place specified control joint strip so top is flush with slab surface.
 - 2) Sawed: After 4 hours and generally before 12 hours after finishing concrete, when it is firm enough to resist raveling, tearing, or dislodging of aggregates, make cut approximately 1½" deep, using power saw, and blow joints clean. (See ACI 301, Section 11.5.)
 - 3) Grooved: Using an appropriate jointing tool, carefully form a narrow groove approximately 1" deep. Do not use this method where heavy traffic is expected.
7. PRODUCTION OF CONCRETE (As per ACI 301, Chapter 7, except as noted.)
- A. Ready-Mixed Concrete shall be used for all work, except that when small quantities (not over 1/2 cu.yd) are needed for isolated or relatively unimportant items, such concrete may be batch mixed at site, subject to the Engineer's prior approval.
- B. Delivery Ticket for each batch of ready-mixed concrete shall give the following information, in addition to that required by ASTM C94, Para. 15.1:
- 1) Water content (W/C ratio)
 - 2) Type, brand and amount of cement
 - 3) Type, brand and amount of admixtures
 - 4) Maximum size aggregate
 - 5) Weights of fine and coarse aggregate
 - 6) Indication that all ingredients are as previously certified or approved



-
8. PLACING (As per ACI 301, Chapter 8, except as noted.)
- A. Preparation Before Placing:
- 1) Cleaning: Remove from reinforcing steel excessive rust, dirt and other coatings that would reduce or destroy bond. Thoroughly clean forms of hardened concrete, wood chips, shavings and other debris.
9. REPAIR OF SURFACE DEFECTS (As per ACI 301, Chapter 9, except as noted.)
- A. Concealed Concrete Surfaces not exposed to view upon completion, may be patched with nonshrink mortar specified herein under Materials: Miscellaneous Items, in lieu of ACI specified mortar.
10. FINISHING OF FORMED SURFACES (As per ACI 301, Chapter 10, except as noted.)
- A. Selection of Finishes:
- 1) Grout Cleaned Finish: Use for all exposed exterior surfaces and interior vertical surfaces not to be painted.
- 2) Smooth Form Finish: Use for all exposed surfaces to be painted, for exposed walls of sumps and equipment pits, and for exposed interior overhead surfaces whether or not painted.
11. SLABS (As per ACI 301, Chapter 11, except as noted.)
- A. Jointing: (See Para. 6 herein.)
- B. Finishes and Tolerances:
- 1) Troweled Finish: Locations where this finish is required include areas of equipment foundations and pads which will be exposed, with Class B tolerance permissible. Use this, with Class A tolerance, for interior floors not otherwise noted on drawings. Perform at least 3 trowelings on concrete to be exposed, and 2 trowelings where finishes are to be applied.
- 2) Broom or Belt Finish: Use with Class B tolerance, for traffic areas and ramps, and for exterior pedestrian walkways, ramps and steps.



C. Floor Depressions for other finishes shall be held to accurate elevations, depending on nature of finish. Transitions occurring under thin-set finishes shall be formed smoothly and uniformly.

12. CURING AND PROTECTION (As per ACI 301, Chapter 12, except as noted.)

A. General: Requirements for curing and protection specified in ACI 301 shall be strictly observed, with particular emphasis on the following:

- 1) Initial and final curing may be accomplished by any of the methods given in ACI 301, Section 12.2, except as noted, using materials specified herein. Methods which add moisture shall do so continuously, not periodically. Attention is called to Para. 12.B.3 herein for limitations on use of curing compound.
- 2) For formed surfaces, keep wood forms in contact with concrete wet, as well as steel forms heated by the sun. After form removal, continue curing for the remainder of required curing period.
- 3) Placement in hot or cold weather shall conform to recommendations given in ACI 305R and 306R, respectively. Submit to the Field Engineer proposed procedures for placing and protecting concrete under these conditions, and receive his approval of arrangements before proceeding.

B. Use of Curing Methods: Maintain curing protection in good condition during required period. Repair, reapply or replace when necessary.

- 1) Water: When excessive amounts of water are used for curing, provide means for removal so that harmful effects to other construction and to earth surfaces will be minimized.
- 2) Waterproof Sheet Materials: Use largest practicable size sheets. Lap joints not less than 4" and seal carefully. Anchor covering securely in place.
- 3) Curing Compound: Apply uniformly at a coverage rate not less than that stated by manufacturer which meets ASTM C309 moisture retention requirement (0.055 gram/sq.cm/72 hr). Limitations on use of curing compound are as follows:



-
- a) Do not use curing compound on areas intended to receive cementitious bonded applications or chemical surface hardener.
- b) Do not use curing compound on areas intended to receive paint or other coatings, thin applied topping, and coverings applied by adhesive or thin-set method.
- 4) Finishing Aid: Use of material specified herein is recommended to retard moisture evaporation from freshly placed concrete when it is exposed to rapid drying conditions: direct sunlight, low humidity, heated interior, high wind, etc. Prepare dilute solution and spray apply on plastic concrete immediately after screeding, at maximum rate of 10 gal. solution/5000 sq.ft. If drying conditions are particularly severe, make additional applications as required following various finishing steps.
- 5) Reflective Materials: During hot sunny weather (generally 75°F and above), use of white or light colored curing materials is recommended to help keep down concrete surface temperature. White or gray pigmented curing compound shall not be used when determined by the Engineer to be objectionable.
13. TESTING (As per ACI 301, Chapter 16, except as noted.)
- A. Testing Services: The Field Engineer will designate an independent testing laboratory to perform testing services for the purpose of maintaining concrete quality. If possible, the selected Laboratory will be one which has been inspected by the Cement and Concrete Reference Laboratory at the National Bureau of Standards (NBS), and which meets ASTM E329, "Recommended Practice for Inspection and Testing Agencies". To conform to this requirement, the Laboratory shall submit to the Engineer a copy of recent NBS inspection report.
- B. Testing Services shall be as listed in ACI 301, Section 16.3, modified and supplemented as follows:
- 1) Sampling, making specimens, capping, handling, curing and testing shall conform strictly to referenced ASTM standards, and each procedure shall be performed by authorized personnel only. Tests for slump, air content and compressive strength are



required, but not for flexure unless specifically ordered in writing by the Engineer.

- 2) Each strength test shall consist of 4 cylinder specimens, 1 tested at 7 days, 2 at 28 days, and 1 held in reserve to be tested when directed by the Field Engineer. The latter may be substituted when another specimen develops a dubious test value. For high-early strength concrete, make 4 cylinder specimens, 1 tested at 3 days, 2 at 7 days and 1 held in reserve.
- 3) Laboratory shall report test results to the Field Engineer.

14. EVALUATION OF CONCRETE STRENGTH

- A. As per ACI 301, Chapter 17, as applicable.

15. ACCEPTANCE OF STRUCTURE

- A. As per ACI 301, Chapter 18, as applicable.

16. GROUTING

A. Grouting Column Bases:

- 1) Mixes: For clearances less than 2", grout mix shall consist of nonshrink grout material (specified under Section 2G, Miscellaneous Items) and water only. For clearances 2" and over where free passage of grout will not be obstructed, add 50 lbs of 1/4" to 3/8" pea gravel for each 100 lbs of dry nonshrink material. Use correct amount of water as determined by conditions of placement.
- 2) Mixing for not less than 3 minutes shall be done in a mortar mixer as close as possible to locations of use. Do not mix more grout than can be placed in 1/2-hour period, and once mixed do not add water to retemper.
- 3) Forms shall be of adequate materials and strength, sufficiently tight to prevent leakage, and securely anchored to withstand applied pressure. Provide access space necessary for grout placement.
- 4) Preparation: Contact surfaces of concrete shall be cleaned of laitance, dirt, oil, grease and loose material, then roughened and saturated with water,



and excess water removed. Metal members and anchor bolts shall be cleaned of dirt, oil, grease and loose material, and aligned, leveled and maintained in correct final position during grouting.

- 5) Placement: Grout shall be placed quickly and continuously, avoiding segregation, bleeding or breaking down of initial set. Grout may be poured, or placed by plunger, pump or pressure, as most practicable. Make sure spaces are completely filled and there are no voids.

- 6) Finishing: After initial set (within 12 to 24 hours), remove forms, cut grout back at 45° from the bottom edge of the base plate, and plaster neatly with Portland cement-sand mortar. Cure grout with wet burlap for first 48 hours. Leveling devices shall remain undisturbed 48 hours after placing grout; upon removal, voids shall be pointed flush.



SPECIFICATION 34-0321

CONCRETE REINFORCEMENT

CLIENT: SHELL OIL COMPANY

PROJECT: ROCKY MOUNTAIN ARSENAL REMEDIATION PROJECT

INTERIM RESPONSE ACTION FINAL DETAILED DESIGN

RAILYARD/MOTORPOOL IRA

LOCATION: ROCKY MOUNTAIN ARSENAL, COMMERCE CITY, CO



CONTENTS

PAGE

PART I - GENERAL

1.	SCOPE	3
2.	RELATED WORK	3
3.	REFERENCE STANDARDS	3
4.	GENERAL PROCEDURES	4

PART II - MATERIALS AND CONSTRUCTION

1.	GENERAL	6
2.	MATERIALS	6
3.	PLACING	6



SPECIFICATION 34-0321

CONCRETE REINFORCEMENT

PART I - GENERAL

1. SCOPE

- A. This specification, the reference standard noted herein (namely ACI 301, as described in Paragraph 3) and other Contract Documents cover furnishing and placing all concrete reinforcement and welded wire fabric as required by the applicable drawings and as specified herein.
- B. Work Included: Generally, the items of work include the furnishing and placing of reinforcing steel and welded wire fabric together with all required accessory items.

2. RELATED WORK

- A. The following related work is covered in other specifications:
 - 1) Cast-In-Place Concrete (Specification 34-0301)

3. REFERENCE STANDARDS

- A. To be complete, this specification requires the use of American Concrete Institute Standard ACI 301, "Specifications for Structural Concrete for Buildings". This project Specification 34-0321 is intended to supplement and modify ACI 301 and will take precedence where conflict exists.
- B. Requirements of ACI 301 shall govern the work, except as noted herein. Except as noted herein, reinforcing work shall conform, in general, to recommended practice contained in related references given in Section 1.5 of ACI 301.
- C. For standards referred to in ACI 301, the edition and supplements in use and currently available at date of this Specification 34-0321 shall apply.
- D. Organizations whose standards are referenced herein or in ACI 301, include the following:



- 1) ACI - American Concrete Institute
 - 2) ASTM - American Society for Testing and Materials
 - 3) AWS - American Welding Society
 - 4) CRSI - Concrete Reinforcing Steel Institute
 - 5) UBC - Uniform Building Code
- E. Any reference to standards of any society, institute, association or governmental agency which is part of the Building Code listed above shall be the edition date published in the referenced Building Code. Any reference to standards which is not part of the Building Code listed shall be the edition in effect as of the date of this specification, unless stated otherwise.

4. GENERAL PROCEDURES

A. Shop Drawings:

- 1) Shop drawings for reinforcement shall be submitted to the Engineer for approval, per contract documents. Resubmit corrected drawings until final approval is obtained.
- 2) Approval of drawings will be for adherence to overall basic design, and will not relieve this Contractor of responsibility for correctness of dimensions, proper design of details, quantities and field fit.
- 3) Shop drawings for reinforcement shall conform to ACI 315, and shall indicate bending diagrams, assembly diagrams, supporting devices, bar dimensions, details, laps and splices. Provide the following quantities of approved drawings for record and distribution:

Setting and erection
plans and details - 5 prints and 1 sepia

Lists of materials - 5 prints and 1 sepia

- B. Samples: Submit to the Engineer or directly to designated testing laboratory samples of such materials associated with this work as he may request, for visual examination and testing. Obtain approval of samples before installation. Materials used in the work shall



conform to approved samples and shall be obtained from same sources, unless otherwise approved by the Engineer.

- C. Certification: On request by the Engineer, submit test reports and other acceptable evidence that materials furnished comply with specified requirements.



PART II - MATERIALS AND CONSTRUCTION

1. GENERAL (Chapter 1, ACI 301)
 - A. Requirements of ACI 301 shall govern the work, except as noted herein. Main paragraph titles herein under Part II give the ACI 301 section being modified or supplemented.
 - B. "Approved" and "approval", as used in ACI 301, shall mean approved by the Engineer.
2. MATERIALS (ACI 301, Section 5.2)
 - A. Bars: All reinforcing bars shall be deformed bars conforming to ASTM A615, Grade 60.
 - B. Welded Wire Fabric: All fabric shall conform to ASTM A185.
3. PLACING (ACI 301, Section 5.5)
 - A. All splices shall be as shown on the design drawings or shall conform to the requirements of ACI 318, "Building Code Requirements for Reinforced Concrete".



SPECIFICATION 34-0325

EMBEDDED ITEMS

CLIENT: SHELL OIL COMPANY

PROJECT: ROCKY MOUNTAIN ARSENAL REMEDIATION PROJECT

INTERIM RESPONSE ACTION FINAL DETAILED DESIGN

RAIL CLASSIFICATION YARD/MOTOR POOL AREA IRA

LOCATION: ROCKY MOUNTAIN ARSENAL, COMMERCE CITY, CO



<u>CONTENTS</u>	<u>PAGE</u>
1. SCOPE	3
2. RELATED WORK	3
3. REFERENCE STANDARDS	3
4. GENERAL PROCEDURES	4
5. MATERIALS	5
6. FABRICATION	5
7. INSTALLATION	6



SPECIFICATION 34-0325

EMBEDDED ITEMS

1. SCOPE

- A. This specification and other Contract Documents cover furnishing all equipment, materials and labor, and performing all operations required to furnish, fabricate, and deliver to jobsite embedded items and anchor bolts, as required by the applicable drawings and as specified herein.
- B. Embedded items covered by this specification shall include, but not be limited to, the following items:
- 1) Embedded angles for curbs, floor plate, and floor grating
 - 2) Miscellaneous embedded plates, angles, channels and other shapes
 - 3) Embedded U-bolts and eyebolts
 - 4) Embedded ladder rungs
 - 5) Embedded pipe sleeves
 - 6) Anchor bolts

2. RELATED WORK

- A. The following related work is covered in other specifications:
- 1) Cast-In-Place Concrete (Specification 34-0301)
 - 2) Concrete Reinforcement (Specification 34-0321)

3. REFERENCE STANDARDS

- A. Organizations whose standards are referenced herein include the following:
- 1) AISC - American Institute of Steel Construction
 - 2) ANSI - American National Standards Institute



- 3) ASTM - American Society for Testing and Materials
- 4) AWS - American Welding Society
- 5) UBC - Uniform Building Code

B. Any reference to standards of any society, institute, association or governmental agency which is part of the Building Code listed above shall be the edition date published in the referenced Building Code. Any reference to standards which is not part of the Building Code listed shall be the edition in effect as of the date of this specification, unless stated otherwise.

4. GENERAL PROCEDURES

A. Shop Drawings:

- 1) Shop drawings shall be submitted for all fabricated items and shall give complete information for fabrication and installation. Use AWS symbols for all welds. Show all holes for attaching or accommodating other work, as required by the design drawings.
- 2) Approval drawings will be for adherence to overall basic design, and will not relieve this Contractor of responsibility for correctness of dimensions, proper design of details, quantities, field fit, and for proper connection with other work.

B. Certification: On request of the Field Engineer, submit test reports or other acceptable evidence that materials comply with the specified requirements. All embedded item materials shall be new.

C. Inspection: All material and items shall be subject to visual inspection in the shop or in the field. Material not meeting the specified requirements shall be promptly removed and replaced with acceptable material.

D. Delivery: Embedded items, together with applicable setting plans or instructions, shall be shipped in the order required for installation continuity, according to a mutually established schedule of delivery dates.



5. MATERIALS

- A. Plates, Shapes, and Bars: ASTM A36 or Type 304 stainless steel if indicated on the drawings.
- B. Pipe Sleeves: ASTM A53, Grade B, standard weight, black steel for indoor use, galvanized for outdoor use or Type 304 stainless steel if indicated on the drawings.
- C. Anchors: For embedded items, ASTM A36 or Type 304 stainless steel if indicated on the drawings.
- D. Anchor Bolts: ASTM A307 or ASTM A36 with suitable nuts. Bolt and nut dimensions shall conform to ANSI B18.2.1 and B18.2.2. Provide 8-pitch thread series for bolts over 1" diameter.
- E. Embedded Ladder Rungs: Round Type 304 stainless steel bar stock of size noted with ends turned in and hooked to provide for not less than 4" embedment. Nonmetallic ladder rungs shall be MA PS-2-PF polypropylene or equal.
- F. Welding Electrodes: AWS A5.1 or A5.5, E70XX series.
- G. Specialty Items: Specialty embedded items shall be as noted on the drawings.
- H. Galvanizing: Conform to ASTM A123 or A153, as applicable, unless otherwise noted.
- I. Prime Paint: Porter Coatings Div./Porter Paint Co., Valspar, Sherwin-Williams Co.

6. FABRICATION

- A. Fabrication of embedded steel items shall be in accordance with the details shown on the drawings, the AISC "Specification for the Design, Fabrication, and Erection of Structural Steel for Buildings", and the AISC "Code of Standard Practices for Steel Buildings and Bridges".
- B. Fabrication shall be welded construction unless the drawings show otherwise. Welding of embedded steel shall conform to AWS D1.1.
- C. Fabrication shall be accomplished in a workmanlike manner. Poor workmanship, even though structurally sound, shall be cause for rejection of items where appearance is a justifiable consideration.



- D. Anchor bolts shall be fabricated in accordance with the details shown on the drawings.
- E. Embedded items and anchor bolts to be galvanized or stainless steel shall be as noted on the drawings.
- F. Surfaces of embedded items, not galvanized or in contact with concrete, shall receive one shop coat of prime paint.
- G. All items shown as stainless steel shall be Type 304 stainless steel.

7. INSTALLATION

- A. Embedded items and anchor bolts shall be installed in the locations shown on the drawings.
- B. Embedded items shall be thoroughly cleaned of dust, oil or grease, grout, and other undesirable coating which would be detrimental to proper bonding with concrete.
- C. Special care shall be taken to place embedded items in their proper locations and to ensure protection against displacement or misalignment during placing of concrete.
- D. Anchor bolts shall be set with templates or by other means for placement in the proper location and to ensure protection against bolt displacement or misalignment during placing of concrete.



SPECIFICATION 34-0503

MISCELLANEOUS METALS

CLIENT: SHELL OIL COMPANY

PROJECT: ROCKY MOUNTAIN ARSENAL REMEDIATION PROJECT

INTERIM RESPONSE ACTION FINAL DETAILED DESIGN

RAIL CLASSIFICATION YARD/MOTOR POOL AREA IRA

LOCATION: ROCKY MOUNTAIN ARSENAL, COMMERCE CITY, CO



<u>CONTENTS</u>	<u>PAGE</u>
1. SCOPE	3
2. RELATED WORK	3
3. REFERENCE STANDARDS	4
4. GENERAL PROCEDURES	4
5. MATERIALS IN GENERAL	5
6. FABRICATION	7
7. INSTALLATION	8
8. SPECIFIC REQUIREMENTS	9
9. SURFACE PREPARATION AND SHOP PAINTING	10
10. CLEANING AND TOUCHING UP	11



SPECIFICATION 34-0503

MISCELLANEOUS METALS

1. SCOPE

- A. This specification and other Contract Documents cover furnishing and installing all miscellaneous metal items (except as noted under Related Work) as required by the applicable drawings and as specified herein.
- B. Items shown on the drawings but not specifically noted herein shall be of quality and workmanship conforming to similar items described herein. Generally, required items of work include:
- 1) Structural frames and members not part of structural steel or pre-engineered buildings: door and other opening frames, loose lintels, and frames for floor openings.
 - 2) Checkered plate: flooring, covers, treads.
 - 3) Steel grating: flooring, covers, treads.
 - 4) Miscellaneous plate and angle assemblies. Closures, thresholds, sump covers.
 - 5) Castings and other parts associated with pits and drainage, which are not covered under mechanical and electrical specifications: manhole and handhole frames and covers, cast gratings, scuppers, ladder rungs, pull-in irons.
 - 6) Miscellaneous parts for assembling and attaching items specified herein: fasteners, sleeves, anchors, inserts, hardware and accessories.
 - 7) Miscellaneous parts for attaching work of other trades which are not covered in other specifications: fasteners, sleeves, anchors, inserts.

2. RELATED WORK

- A. The following related work is covered in other specifications:



- 1) Concrete fill and grouting, reinforcement for concrete, embedment of miscellaneous items in concrete (Specifications 34-0301 and 34-0321)
- 2) Concrete Reinforcement (Specification 34-0321)
- 3) Pipe and conduit sleeves and supports (under respective mechanical and electrical specifications).
- 4) Field Painting (Specification 33-0914)

3. REFERENCE STANDARDS

A. Organizations whose standards are referenced include the following:

- 1) AISC - American Institute of Steel Construction
- 2) ANSI - American National Standards Institute
- 3) ASTM - American Society for Testing and Materials
- 4) AWS - American Welding Society
- 5) SSPC - Steel Structures Painting Council
- 6) UBC - Uniform Building Code

B. Any reference to standards of any society, institute, association or governmental agency shall be the edition in effect as of the date of this specification, unless stated otherwise.

4. GENERAL PROCEDURES

A. Shop Drawings are required to show fabrication details, erection diagrams, and notes on materials, finish and anchorage. All drawings submitted shall bear the stamp of approval of the Contractor as evidence that the drawings have been checked by him.

B. Inspection: Fabricated miscellaneous metal items shall be subject to visual inspection, which will be done at place of fabrication whenever possible. Fabricator shall provide information and access for inspection. Promptly remove material rejected by the Field Engineer and replace with acceptable material.



- C. Field Measurements: Verify dimensions, locations and elevations of anchors, bolts, plates and other items, and be responsible for proper fitting of miscellaneous metal work. Report to the Field Engineer any errors or discrepancies so that correction may be made.
- D. Delivery: Ship miscellaneous metal items in the order required for erection continuity according to a mutually established schedule of delivery dates. Furnish parts which require embedment, together with applicable instructions, in ample time for setting in the work.
- E. Handling: Assume responsibility for and repair damage to this and other work resulting from handling miscellaneous metal items or from failure to maintain adequate precautions. Handle so that metal items and shop primer will not be damaged, and surfaces will be free of mud, dirt and other foreign substances.
- F. Storing: If required, adequate storage space for metal items and for necessary tools and equipment will be allocated at site. Keep stored parts clear of ground by means of timbers and blocking, and properly drained.

5. MATERIALS IN GENERAL

- A. Structural Steel Shapes, Bars and Plates: ASTM A36 or Type 304 stainless steel. Furnish all new materials.
- B. Checkered Plate: Low carbon steel floor plate with raised lugs, large pattern; prime painted for indoor use, galvanized for outdoor use.
- C. Steel Bar Grating: Standard welded rectangular type, with bearing bars of size noted spaced 1-3/16" OC, and straight, twisted or hexagonal cross bars spaced 4" OC. Grating shall conform to ANSI A202.1, Metal Bar Grating Manual, and be prime painted for indoor use, galvanized for outdoor use.
- D. Nonmetallic Bar Grating: Nonmetallic grating shall be "Chemgrate" fiberglass grating of size as shown on the drawings, as manufactured by Chemgrate Corporation, Woodinville, WA, or approved equal.
- E. Steel Pipe: ASTM A53, Grade B, standard weight, black steel for indoor use, galvanized for outdoor use.
- F. Abrasive Surfacing on castings shall consist of aluminum oxide or silicon carbide granules firmly embedded into



molten metal matrix to 1/16" depth. Granules shall range in size from No. 12 to 24, and be distributed uniformly at rate of 2 oz/sq.ft.

- G. Iron Castings: ASTM A48, not less than Class 30 with 30,000 psi tensile strength. Castings shall be tough and free from cracks, flaws, blow holes and other defects. Coat surfaces with high grade asphalt protective material.
- H. Connectors and Fasteners: Bolts, nuts and washers shall conform to ASTM A307 or Type 304 stainless steel if indicated on the drawings. Provide expansion shields, cinch anchors, toggles and other appropriate fasteners and anchors as required. Do not use fiber plugs outdoors. Steel and iron parts of connectors and fasteners exposed outdoors shall be galvanized or cadmium plated.
- I. Adhesive Anchors: Adhesive anchors shall be capsule-type HVA as manufactured by Hilti, Inc.; Redi-Chem anchors as manufactured by the Phillips Drill Company; Parabound Capsule Anchors manufactured by the Molly Division of Emhard Corporation; or equal. Anchors which use a pour-in or injection system for the epoxy resin placement may be used, provided that test data are submitted substantiating the equivalence of tensile and shear capacities to the capsule-type anchors specified herein. Unless otherwise noted, adhesive anchors shall be stainless steel, Type 316.
- J. Welding Electrodes: AWS A5.1 or A5.2, E70XX series.
- K. Hardware for hinged covers and other operating parts: heavy duty industrial type appropriate for the application; of unplated steel or iron having primed finish for painting where used indoors, galvanized or cadmium plated where used outdoors.
- L. Galvanizing: Where exposed outdoors and elsewhere as noted, the following shall be galvanized: floor plate, grating, plate thresholds and sills, hardware and fasteners. Bolts, including nuts and washers, shall be zinc coated conforming to ASTM B454, Class 50. Other items shall conform to ASTM A123, A153, A386 or A525 as applicable, 1.25 oz/sq.ft class.



M. Paint Materials:

- 1) Shop Primer: Multipigment alkyd, quick dry, structural metal primer: Porter 297, Valspar 91453, Sherwin Williams B50N2.
- 2) Cold Galvanizing Compound (Touch-up): Ready-mixed zinc-rich coating containing 95% metallic zinc by weight: Galvicon of Galvicon Corp; ZRC of The Sealube Co; Galvonox Type I of Subox Coatings Div, BASF Wyandotte Corp; or Engineer approved equal.

6. FABRICATION

- A. General: Fabricate miscellaneous metal work in accordance with design drawings and as detailed on approved shop drawings. Conform to applicable requirements of the AISC "Specification for the Design, Fabrication and Erection of Structural Steel for Buildings," (latest edition) and "Code of Standard Practice for Steel Buildings and Bridges," (latest edition); except as modified by this specification, applicable drawings, and the governing laws, codes and ordinances.
- B. Design: Components not completely detailed and members not sized on design drawings shall be proportioned to provide ample strength and stiffness under expected loads. Joints exposed to weather shall be formed to exclude water or to drain.
- C. Assembly and Connections: Insofar as practicable, assemble work in the shop, ready for field installation. Connect by welding or bolting in manner to develop strength of members involved. Wherever possible, bolts shall be concealed.
 - 1) Bolting: Bolts shall be of proper length to permit full thread in the nut, but to project no more than 1/4". Use a lock washer under the nut for connecting items subject to moving traffic or vibration.
 - 2) Welding shall be performed preferably in flat position, by shielded or submerged electric arc methods or gas metal arc method only, using proper electrodes for conditions of use, in accordance with AWS D1.1, "Structural Welding Code." Make welds smooth and regular, solid and homogenous throughout, and free from pits, slag, scale and other defects.



Where exposed to weather, welds shall be continuous, unless otherwise noted.

D. Workmanship:

- 1) Make all work square, plumb, straight and true, accurately fitted, with tight joints and intersections, and neat in appearance. Members shall have sharply defined profiles and be free from twists, bends and defects impairing strength and durability. Items not presenting a finished and workmanlike appearance will be rejected.
- 2) Cut members accurately; standard gas cutting machine may be used in the shop if ends and edges can be finished so that appearance is acceptable. Use extra care in making miters. Provide all required holes for this and other work, by drilling or punching, and wherever necessary, countersinking.
- 3) Provide all required supporting members, bracing, brackets and reinforcement, as well as straps, lugs, clips, anchors and other connections to facilitate installation and anchorage.
- 4) Clip off projecting edges and corners. Finish and dress surfaces, edges and welds smoothly and neatly by grinding, chipping and wire brushing. Reduce sharp edges by grinding to 1/4" radius.

7. INSTALLATION

- A. Coordinate miscellaneous metal installation with other work in a manner which will facilitate and expedite project completion. Erect work to proper lines and levels, plumb and true, and in correct relation to other work.
- B. Secure work in a rigid and substantial manner with appropriate fasteners, concealed wherever practicable. Do not enlarge holes without the Engineer's prior written approval.
- C. Obtain the Field Engineer's prior approval before any gas cutting is done in the field. Do not cut any structural steel members.
- D. Provide guys, bracing and falsework for temporary support where necessary. Remove them after permanent work is



self-supporting but not until required inspections have been made.

8. SPECIFIC REQUIREMENTS

A. Structural Frames and Members:

- 1) Fabricate frames from rolled sections as required by drawings, with mitered corners continuously welded and ground smooth. Make each member of one piece; short sections butt-welded together are not permitted. Select frame sections for trueness of web and flange, and straighten as required so that finished frames are uniform, square and true. Provide suitable anchors for attachment to other materials, welded on, or adjustable type to accommodate coursing.
- 2) Frames for hinged doors shall have flat bar stops plug-welded to frame. Make cutouts, drill and tap for hardware, as required, per templates to be furnished by hardware supplier. Provide dust covers welded in place behind door strikes.
- 3) Extend jamb members above door head and provide supplementary plates where necessary to support tracks, guides, hoods, hangers, operators and other accessories.
- 4) For lintel members, provide sufficient end bearing area to support imposed loads; extend not less than 6" at each end. Weld or rivet built-up members together, with separators if required. Where in combination with door or other opening frames, tack weld lintel members to frames.

B. Steel Stairs: Construct in accord with best standards for steel stairs, with all stringer joints mitered, welded and ground smooth. Parts shall be of sizes, sections and weights required by drawings. When installed, stairs shall be rigid and free of vibration or rattle under load of moving traffic. Provide patterned steel nosing on grating type treads.

C. Checkered Plate Items: Fabricate steel floor plate as specified herein. Attach flooring to steel supports by welding or flush bolting. For removable or hinged covers, provide necessary hardware and accessories as applicable: hinges, lifting rings or latch, rubber sealing gasket, etc.



- D. Steel Bar Grating Items: Fabricate into convenient size panels, according to requirements specified herein under Materials. Make openings where shown on drawings, band openings and exposed ends with steel bars, and reinforce as required for adequate support. Provide patterned steel nosing on grating treads. Attach floor grating permanently to supporting members with a minimum of four 3/16" x 3/4" long fillet welds per grating panel. Where required to be removable, secure grating with bolts and clips.

9. SURFACE PREPARATION AND SHOP PAINTING

- A. General Requirements: Take special care to perform this work as specified herein and in the reference standards. Any miscellaneous metal items delivered to the site on which the painting workmanship is judged defective will be rejected, and the Field Engineer will determine corrective measures to be taken.

- B. Required Coatings of shop applied paint are as follows:

Surfaces and edges to be field welded, surfaces to be encased in concrete, machine finished surfaces, and galvanized surfaces	- None
Surfaces inaccessible after assembly	- 2 coats
Iron castings	- see Para. 5G
All other surfaces	- 1 coat

- C. Surface Preparation: Remove loose mill scale and loose rust to the degree defined, and completely remove oil, grease and foreign matter, as required by SSPC-SP2, Hand Tool Cleaning, and/or SSPC-SP3, Power Tool Cleaning.

- D. Shop Painting: When clean and dry, surfaces shall be painted in accordance with SSPC-PA1, Paint Application Specifications, and the paint manufacturer's recommendations. Apply specified shop prime paint by brush, spray or roller in a manner to cover entire surface smoothly, thoroughly and uniformly. Apply at proper coverage rate to provide average dry film thickness (dft) of 2 mils. Fabricator will be required to recoat any areas where the dft is less than this specified average.



-
- E. Unpainted Surfaces: Remove oil, grease, dirt and other foreign matter by cleaning with solvent and by brushing.
 - F. Machined Surfaces: Protect from corrosion by applying an approved rust preventive coating such as Rust Veto 243 of E.F. Houghton & Co., Philadelphia, PA, or Engineer approved equal.

10. CLEANING AND TOUCHING UP

- A. Leave work free from dirt, weld spatter, grease and oil. Prime paint field connected bolts, welds, and damaged areas of shop applied primer, with one coat of same brand and kind of paint used for shop painting, to form an unbroken prime coat ready for finish painting under Specification 33-0914. Touch up welds and damaged areas of galvanized surfaces with specified cold galvanizing compound. Before touching up, thoroughly clean areas to be painted of loose scale, rust and foreign substances by SSPC-SP2, Hand Tool Cleaning, and/or SSPC-SP3, Power Tool Cleaning.



MORRISON KNUDSEN CORPORATION
ENVIRONMENTAL SERVICES GROUP

SPEC NO.: 35-1501
W.O. NO.: 2127-22
DATE: 11/30/90
ISSUE/REV.: 0
PAGE: 1

SPECIFICATION 35-1501

GENERAL SPECIFICATIONS FOR PIPING

CLIENT: SHELL OIL COMPANY

PROJECT: ROCKY MOUNTAIN ARSENAL REMEDIATION PROJECT

INTERIM RESPONSE ACTION FINAL DETAILED DESIGN

RAIL CLASSIFICATION YARD/MOTOR POOL AREA IRA

LOCATION: ROCKY MOUNTAIN ARSENAL, COMMERCE CITY, CO



<u>CONTENTS</u>	<u>PAGE</u>
1. INTENT	3
2. RELATED WORK	3
3. REFERENCE STANDARDS	4
4. MATERIALS	5
5. SUBSTITUTIONS	7
6. UNDERGROUND PIPING SYSTEMS	7
7. WELDING, FABRICATING AND INSPECTING	11
8. ERECTING PIPING	11
9. PIPE HANGERS AND SUPPORTS	13
10. VENTS AND DRAINS	14
11. TESTING	15
12. FINAL CLEANING	17
13. IDENTIFICATION	18
14. ACCEPTANCE	18
15. PIPE CONSTRUCTION SPECIFICATION NO. 1	19
16. PIPE CONSTRUCTION SPECIFICATION NO. 2	21
17. PIPE CONSTRUCTION SPECIFICATION NO. 3	21
18. ATTACHMENT: STAINLESS STEEL WELDING PROCEDURE SPECIFICATION & QUALIFICATIONS	



SPECIFICATION 35-1501

GENERAL SPECIFICATIONS FOR PIPING

1. INTENT

- A. This specification is intended to cover general requirements for fabricating, installing, testing and other phases of piping work. These requirements apply except as they may be modified by statements in other project specifications covering specific piping systems, the drawings and other documents.
- B. The Contractor shall furnish and install all materials, labor and equipment for the piping systems, as shown on the drawings and/or called for in the specifications.
- C. The Contractor shall furnish all necessary inspection reports, approvals, certificates and labels, stamps or nameplates required by the specific reference standards cited in the individual specifications for materials and equipment or component parts.
- D. All pertinent manufacturer's installation and operating instructions form a part of this specification.
- E. Inspectors representing the Owner shall have access at all reasonable times to all sections concerned with the fabrication and installation of piping under the Contract. Such an inspector may reject any materials, procedures or work which fails to meet the requirements of applicable codes, specifications, procedures, drawings or purchase orders.

2. RELATED WORK

- A. The following related work is covered in other specifications:
 - 1) Asphaltic Concrete Pavement, Unpaved Service Road, and Railroad Crossing (Specification 34-0218)
 - 2) Site Preparation, Grading, Excavating and Backfilling (Specification 34-0212)
 - 3) Cast-In-Place Concrete (Specification 34-0301)



4) Manholes (Specification 35-1511)

3. REFERENCE STANDARDS

A. The equipment and/or its component parts shall be designed, manufactured and tested in accordance with the applicable requirements of the latest edition of the following codes, standards, references, and any pertinent regulations of local, municipal, county and state authorities:

- 1) ANSI - American National Standards Institute
- 2) ASPE/ - American Society of Plumbing Engineers/
PHCC Association of Plumbing-Heating-Cooling Contractors
- 3) ASTM - American Society for Testing and Materials
- 4) HEW/ - U.S. Department of Health, Education and
PHS Welfare/Public Health Service
- 5) PFI - Piping Fabrication Institute
- 6) AWWA - American Water Works Association
- 7) AWS - American Welding Society
- 8) MSS - Manufacturers Standardization Society
- 9) UPC - Uniform Plumbing Code
- 10) NPC - National Plumbing Code
- 11) OSHA - Occupational Safety and Health Administration
- 12) Text, "Plastic Piping Systems," by David A. Charis.
- 13) Plastic Piping Institute

B. Any reference to the above standards shall be of the edition in effect as of the date of this specification, unless stated otherwise.



4. MATERIALS

A. General:

- 1) Wherever the word "piping" is used, it shall be understood to refer to complete systems installed or erected in place including pipe, tubing, fittings, flanges, valves, hangers, supports, gasketing, and similar accessory items.
- 2) Throughout the work, materials shall be new, clean, of first class commercial quality; and free from defects. Maintain materials in good condition after delivery to the site.
- 3) Material requirements for such items as pipe hangers, water piping shock absorbers, and identification markers are specified elsewhere herein. For other piping materials, see applicable pipe construction specifications with other sections.
- 4) Where no specific requirements are given for equipment drain and vent piping, subcontractor shall provide materials and construction appropriate for the service involved.
- 5) All PVC pipe and fittings shall be PVC manufactured from a compound that meets the requirements of Type 1, Grade 1, polyvinyl chloride as outlined in ASTM D1784. A Type 1, Grade 1 compound is characterized as having the highest requirements for mechanical properties and chemical resistance.
- 6) The compound from which PVC pipe is produced shall have a design stress rating of 2,000 psi at 73°F, listed by The Plastic Pipe Institute.
- 7) PVC pipe shall conform to the requirements of ASTM D1785. Fittings shall conform to the requirements of ASTM D2467 for Schedule 80 socket type and ASTM D2464 for Schedule 80 threaded type and/or flange. Any PVC socket and threaded connections shall be joined and installed using the manufacturer's recommended procedure.
- 8) High density polyethylene pipe (HDPE) shall conform to ASTM D3350 as having a cell classification of PE 345434C. Dimensions and workmanship shall conform



to ASTM F714. HDPE fittings shall be rated by the manufacturer for pressures as high as the pipe to which they are being attached. HDPE pipe shall be SDR 17 (100 psi pressure rating) except where otherwise noted on the plans where SDR 21 is required. Any HDPE connection shall be jointed and installed using the manufacturer's recommended procedure.

- 9) Characteristics of stainless or carbon steel pipe shall be as shown on drawings and in specifications for related work.
- 10) Any PVC or HDPE pipe and fittings shall be supplied by an approved manufacturer.
- 11) Pipe restraint design shall be as shown on the drawings and specifications. Any changes from indicated design shall have the Engineer's prior written approval.
- 12) Wherever the word "Engineer" is used, it shall be understood to refer to the Engineer of the managing authority, or Owner's representative.

B. Valves:

- 1) Valves shall conform to applicable ANSI standards. Screwed valves shall conform to respective manufacturer's standards for overall dimensions.
- 2) The 4" dia. butterfly valve to be installed in the main line just downstream of the flowmeter and upstream of the influent sump shall have a Cv of at least 550 when fully open, and a Cv of not more than 100 when 20% open. Data sheets for the butterfly valve shall be submitted for approval by the Engineer.
- 3) Valve accessories such as packing, gaskets, discs and lubricants shall be suitable and as recommended by manufacturer for service intended.

C. Flanges: Van Stone-type flanges will be used at flanged connections in the piping network.



5. SUBSTITUTIONS

- A. Unless otherwise noted in project specifications, bidder may propose at time of bidding, substitutions of same materials or equipment by other manufacturers (generally termed as "approved equal") which he considers comparable with or better than specified products. It is recognized that substitutions may be offered for reasons other than lower initial cost. If no mention of substitutions is made in the proposal, it will be presumed bidder intends to furnish products as specified.
- B. The Engineer will be the sole judge of acceptability of proposed substitutions, with suitability for intended use as the major criterion. Bidder shall be responsible for providing sufficient information for proper evaluation, including complete identification and description, space requirements, price and delivery time. If substitutions require engineering changes, the Engineer's prior written approval shall be obtained, and cost of such changes shall be borne by the successful bidder.

6. UNDERGROUND PIPING SYSTEMS

A. General:

- 1) The underground installation of any piping system, using any piping material (steel, concrete, cast iron, plastics, clay, etc.) shall satisfy the Codes and Regulations of the authorities having jurisdiction at the site. If no such Codes or Regulations exist, the ANSI Standards or recommendations of the manufacturers, manufacturers' associations, or other technical organizations involved in the manufacturing, fabrication, installation or utilization of the specific piping material, as indicated in the applicable specification, shall govern.
- 2) This section (i.e., 6. Underground Piping Systems) of this specification contains general recommendations for open-trench construction of underground piping systems and shall be used in accordance with the specific recommendations mentioned under paragraph 1) above.
- 3) If tunneling or jacking is utilized for road or railroad crossings, the subcontractor shall submit



to the Engineer the details of the construction method that he prefers and secure the Engineer's written approval prior to beginning the work.

B. Pipe Laying:

- 1) Instruction: Installation workers shall be instructed in the proper handling and joining techniques. Piping shall not be thrown, whipped, or dropped during handling.
- 2) Storage: In outside storage, PVC pipe and fittings shall be covered with light tarpaulin to prevent excessive heat build-up. Loose pipe stacks shall not exceed 3 feet in height.
- 3) General:
 - a) Pipe laying in trenches shall follow excavation as closely as possible. Pipe to be located underground shall be laid in dry trenches maintained free of accumulated water.
 - b) Carefully inspect pipe and fittings before installation. Items which are cracked or otherwise defective shall be rejected, broken and removed from the site immediately.
 - c) Lay pipe in such a manner that bottom of pipe is uniformly supported in compacted bedding material. Fill areas excavated to lower than planned elevations with additional bedding material.
 - d) Where the frost line has penetrated the soil prior to backfilling, the soil shall be thawed out prior to backfilling. Backfill must be free of frozen material.
 - e) For PVC piping, the line should be installed with one end being left free. The pipe shall then be brought to within 15°F of the expected service temperature ($54^{\circ} \pm 15^{\circ}\text{F}$) and the final connection made.
 - f) Install caution tape as indicated on the drawings.



- 4) Sleeves/Encasement for Piping: Where required by drawings, to accommodate passage of certain piping services under roads, or railroads, furnish and install pipe sleeves of size and material noted.
 - 5) Cleaning and Protecting: Clean piping interior of dirt and other foreign matter. For pipe installed in lengths up to 50 ft, keep a swab in the line and pull it past each joint after its completion. Protect open ends of pipe with temporary stoppers or covers. (See Final Cleaning herein.)
 - 6) Inspector must sign off on installation of all underground piping systems prior to backfilling.
- C. Bedding: Pipe shall be bedded on material free from rock particles greater than 1/2-inch diameter in such a way as to support the full barrel length. If natural bedding materials do not meet these requirements or will not provide adequate pipe support, over-excavate and place a minimum of 4 inches of tamped sand to provide pipe support.
- D. Backfilling:
- 1) After the pipe is bedded and successfully initially tested as described under Section 6.F, the pipe shall be covered with a minimum of 12 inches of soil free of rocks, debris, or particles larger than one-half inch. Pipe joints, however, shall be left exposed. This initial backfill layer shall be tamped and compacted to at least 80% of standard proctor density to restrain the pipe during high-pressure testing, and to act as a cushion for final backfill.
 - 2) After successfully passing the high-pressure test, the initial soil cover shall be compacted on both sides of the pipe, with special care at the pipe haunches. Material placed at pipe joints shall not be compacted. Final backfill shall not contain any large sharp rocks in the first 18 inches that could penetrate the initial cushioning layer. Afterwards, the remaining backfilling will be accomplished according to Specification 34-0212, "Site Preparation, Grading, Excavation, and Backfilling."



E. Testing:

- 1) After the pipe is bedded, an initial hydrostatic test shall be conducted at 10% of maximum test pressure, not to exceed 50 psi, to ascertain any initial leakage. Solvent-cemented joints shall have dried for the period of time specified by the manufacturer based on the surface temperature. After a successful initial test, sufficient backfill shall be placed as mentioned above to prevent pipe movement during subsequent high-pressure testing.
- 2) The high test pressure shall be approximately 1.5 times the maximum operating pressure.
- 3) Maximum operating pressure shall be assumed to be 100 psig, for all SDR 17 pipe, and 110 psig for all SDR 15.5 pipe, and 80 psig for SDR 21 pipe.
- 4) The high-pressure test shall be conducted for a period of not less than 2 hours. To successfully pass the high-pressure test, no leakage shall be allowed. The manufacturer's recommendation shall be followed to determine allowable pressure drop or make up water during the testing period.

F. Air Release Valves: Air release valves shall be cast-iron body with stainless steel trim. Valves on the 8-inch pipeline shall have an orifice diameter no smaller than 1/8-inch, nor larger than 3/32-inch. Valves on the 3-inch pipelines shall have an orifice diameter no smaller than 1/16-inch nor larger than 1/8-inch. Valves shall be rated by the manufacturer for complete shut-off at any water pressure from 2-110 psi. Valves shall be as manufactured by GA Industries, APCO, Crispin, or Engineer approved equal. Air release valves shall be positioned, and adjacent piping laid, such that the air release valves are located in all high points of the pipeline.

G. Crossings of Underground Utilities: All crossings with other in-service pipelines and other in-service utilities (not including the sewer line) shall be made such that a 6" minimum clearance is maintained between the new pipeline and the existing line. Where practical, the vertical distance between the two pipes shall be at least 2 ft, but in no case shall the vertical distance be less than 6 inches.



7. WELDING, FABRICATING AND INSPECTING

- A. Welding of miscellaneous supports may be performed by welders not qualified under the code, subject to the Engineer's discretion. Such welders shall prove their ability to weld by performing such tests as are deemed necessary for type of welding involved.
- B. All welding surfaces shall preferably be prepared by machining and grinding. Flame cutting may be used if the cut is smooth and true and all heavy oxide is thoroughly cleaned from flame cut surfaces, in accordance with the applicable Regulation and Codes.
- C. All welding surfaces shall be cleaned and shall be free of paint, oil, rust and mill scale. The contact surfaces between pipe and pipe restraint, and between any sliding surfaces shall also be cleaned and free from any foreign debris.
- D. All threaded pipe restraint connections shall be cleaned and coated with a suitable anti-seize agent prior to assembly.
- E. All solvent weld connections for PVC piping shall be primed prior to solvent cement application. All connections shall conform to manufacturer's recommendations.

8. ERECTING PIPING

A. General:

- 1) Install piping as close as possible to locations shown on drawings. Notify the Engineer when any conflicts arise during erection of piping. No improvising or field changes will be permitted without the Engineer's prior written approval.
- 2) Use full lengths of pipe wherever possible, short lengths with couplings will not be permitted. Cut pipe to exact measurement and install without springing or forcing.
- 3) Avoid tool marks and unnecessary pipe threads. Remove burrs formed when cutting pipe, by reaming, and excess weld spatter and slag from welded joints, by peening, chipping and wire brushing.



- 4) The piping installation shall be coordinated with the work of other trades and other subcontractors so that there are no interferences between piping and cable trays, plumbing, heating, ventilating, dust control, insulation or other installations.
 - 5) All threaded pipe shall be made in accordance with ANSI B2.1.
 - 6) Unless otherwise specified on the drawing, all flange bolt holes shall straddle centerline of equipment and piping.
- B. Slope: Maintain an accurate and uniform slope where lines are purposely pitched for drainage to prevent pocketing when full of liquid. No lines shall have pockets due to changes in elevation unless otherwise indicated on drawings.
- C. Changes in Direction shall be made with pipe and fittings.
- D. Flanged Connections: Use proper length bolts for each size flange. Bolts with excessive length of exposed threads will not be permitted, and will be replaced or cut to correct length at the Contractor's expense.
- E. Unions shall be installed in all piping connections to equipment, regulating valves and wherever necessary for dismantling of piping or removal of valves and other items requiring maintenance. Flanges on equipment may be considered as unions, unless otherwise indicated on drawings. Provide dielectric unions at connections of dissimilar metals.
- F. Pump Strainers: Furnish and install temporary pump strainers for initial unit start-up where permanent strainers are not provided. Temporary strainers shall be removed by the start-up crew after cleaning and flushing systems and run-in of equipment, and before general tightness test.
- G. Cleaning and Protecting: Exercise reasonable care to prevent entry of foreign matter during handling, assembling and erecting. Use compressed air, wire brush, solvent and other acceptable means to remove residual scale, dirt and other foreign matter from interior of piping before final connections are made. Protect open



ends of pipe by capping or plugging. (See Final Cleaning herein.)

9. PIPE HANGERS AND SUPPORTS

A. General:

- 1) Aboveground piping systems inside and outside buildings shall have anchorages, sway braces, guides and supports as required by applicable portions of ANSI B31 Code for Pressure Piping unless otherwise noted.
- 2) Pipe supports and hangers shall be provided and installed by the Contractor to suit actual field conditions for all areas, except where type and location is specifically indicated on the drawings.
- 3) Use of building steel for supporting hangers will be permitted only where indicated on drawings or approved in writing by the Engineer. Do not: weld transversely across the tension flange of any member under stress; use bracing, girts, and other secondary members for support.
- 4) Support vertical piping in a proper manner with approved steel brackets to prevent swaying, sagging, vibration and resonance; however, it shall not be so restrained as to cause lines to snake or buckle between supports or anchors. Do not use flat steel strap hangers.

B. Types of Devices:

- 1) Except as otherwise noted, use ITT Grinnell adjustable wrought iron hangers, Figure 269 for 1-1/4" and smaller pipe, and Figure 260 clevis type, for 1-1/2" and larger pipe. Where copper tubing is directly supported use ITT Grinnell Figure CT69 and CT65 copper plated hangers. Engineer approved equals by other manufacturers are acceptable.
- 2) Hangers from concrete work shall be secured to galvanized Unistrut P3253 through P3270, or Engineer approved equal, metal inserts shall be cast into concrete at time of placing. When the use of these inserts is not possible, attachment shall be made by either: a) anchor bolt set in place with fast setting high strength cement, Hallemite Por-Rok of



Lehn & Fink Div., Sterling Drug Inc., or b) controlled energy type powder actuated fastener of Hilti Fastening Systems, or c) Snap-Off hanger shall be self drilling expansion type, Red Head Phillips anchors. Engineer approved equals by other manufacturers are acceptable.

C. Supports for Insulated Piping:

- 1) For insulated hot and cold lines, unless otherwise shown on drawings, use ITT Grinnell 186 Series, or Engineer approved equal, pipe saddles welded to pipe lines as required for supporting piping from exterior of insulation. At time of installation fill them with insulating cement. In lieu of saddles, pipe 2" and smaller may be supported from insulation with galvanized steel half round protective shields.
- 2) For vertical piping 4" and larger, provide angle or plate type insulation supports welded to pipe at approximately 12' intervals. Fabricate these supports of same material as pipe to which they are attached, and of widths less than thickness of insulation covering.

D. Support Spacing:

- 1) For standard weight or heavier steel pipe the maximum support spacing shall conform to applicable portions of ANSI B31, Code of Pressure Piping.
- 2) Support spacing for pipe of light gauge metal, cast iron, plastic, rubber, glass or other special materials shall be as required by appropriate specifications for the piping involved, or as detailed on the drawings.

10. VENTS AND DRAINS

- A. All high point vents and low point drains shall be made with PVC applicable fittings where possible using a block valve blinded or plugged. For high point vents provided for hydrostatic testing purposes only, the valve may be omitted and a screwed PVC cap substituted.
- B. All equipment vents and drains to have block valve with screwed capped end.



- C. The minimum size vent and drain connections in piping shall be 3/4" unless otherwise limited by pipe size or equipment connections.
- D. Instrumentation Connections, Blocks, and Bleeds:
- 1) Where shown on P&ID and individual piping drawings process sensing piping and sample connections with required pipe connections, valves, tubing, fittings, and supports, etc., shall be provided under this specification.
 - 2) Supply or installation of instruments is not a part of the contractors responsibilities under this specification (see reference Specification 38-3750).
 - 3) Connections for process sensing and sample collection taps shall utilize stainless steel bleed rings, tapped with 1/2" FPT connection port. Bleed rings will be held in place by sandwiching ring between adjoining PVC bolted pipe flanges.

11. TESTING

A. General:

- 1) The Contractor shall perform all cleaning, flushing, and testing including conveyance of test water from Owner-designated source to point of use, and including all disposal thereof, complete and acceptable, for hydraulic structures and appurtenant piping as specified herein and in accordance with the requirements of the Contract Documents.
- 2) The Contractor shall submit minimum 48-hour advance written notice of its proposed testing schedule for review and concurrence of the Engineer. The Contractor's proposed plans for water conveyance, control, and disposal shall also be submitted in writing. The Contractor shall submit a description of all proposed test procedures to the Engineer for approval. No testing shall be conducted until Engineer's written approval of the test procedures is obtained.
- 3) Water for testing will be furnished by the Owner; however, the Contractor shall make all necessary



provisions for conveying the water from the Owner-designated source to the points of use.

- 4) Piping shall be tested after installation but before final backfilling of underground lines, and before insulation of aboveground piping by others.

B. Procedure:

- 1) Perform testing of piping when ambient air conditions are approximately constant.
- 2) Furnish all test pumps, gauges, equipment, and personnel required, and test as necessary to demonstrate the integrity of the finished installation to the approval of all pertinent authorities and the Engineer.
- 3) Chemical piping and water piping systems shall be hydrostatically tested to 1-1/2 times operational pressure for a period of two hours with a zero pressure drop indicating a leak-free system. Repair all leaking joints and retest. PVC piping may be pressure tested up to 100% of its hydrostatic pressure rating after joints are thoroughly dried.
- 4) Test all valve bonnets for tightness. Test operate all valves at least once from closed-to-open-to-closed positions while valve is under pressure. Test all automatic valves for proper operation at the settings indicated. Test pressure relief valves at least three times.
- 5) Test all piping specialties for proper operation. Test all air vent points to ensure that air has been vented.
- 6) The Field Engineer shall witness and approve the piping test.
- 7) Air or compressed gas shall not be used for pressure testing of piping assemblies.
- 8) Drainage systems, including drain, waste and vent piping, shall be tested with water, in presence and to satisfaction of local inspector and according to governing plumbing codes.



- C. Drainage Systems, including sewer, drain, soil, waste, vent and downspout piping shall be tested with water, in presence and to satisfaction of local inspector and according to governing local plumbing codes, if any; otherwise ASPE/PHCC National Standard Plumbing Code, or Uniform Plumbing Code.
- D. Test Records:
- 1) Accurate test records shall be kept on each line or system tested. Tests are to be conducted in the presence of the Engineer.
 - 2) After testing of all piping on the job is complete, the test records shall be given to the Field Engineer.
 - 3) Test records shall include for each test:
 - a) Identification of piping system.
 - b) Testing medium.
 - c) Testing pressure.
 - d) Time of test.
 - e) Date of test approval.
 - f) Signature of test supervisor.
- E. Spool pieces or blank flanges shall be used to replace instruments or control valves, if necessary, to protect them from overpressure or contamination when testing piping systems.

12. FINAL CLEANING

- A. Make sure interiors of piping systems are clean after assembly and before start-up, and exterior surfaces are reasonably clean and ready for subsequent finishes. Perform necessary cleaning in addition to that done at time of piping construction. Obtain the Engineer's prior approval of specific procedures.
- B. In general, instrumentation and equipment shall be disconnected or blanked off from system undergoing cleaning. Flushing through control valves and similar items will not be permitted.



- C. Thoroughly remove any foreign fluids used for testing. When flushing with water, establish flow from high to low points, and drain completely, separating flanges and removing spool pieces where necessary. Blow dry with air, systems used for gases. Dispose of effluent streams from cleaning operations as directed by the Field Engineer.

13. IDENTIFICATION

- A. Lines requiring identification shall be marked after completion of installation and insulation (where required), by means of self-sticking pipe markers applied by the responsible piping services Contractor, as directed by the Engineer. Background colors for markers shall be subject to the Owner's approval and as required for proper contrast with color of piping to afford maximum visibility.
- B. Markers shall be W. H. Brady Company's All Temperature Perma-Code Pipe Markers of No. B-500 impregnated vinyl-cloth protected with No. SPO-9 silicong plastic over-coating, or Engineer approved equal, conforming to requirements of ANSI A13.1, Scheme for Identification of Piping Systems. Markers shall consist of labels and directional arrows.
- C. Install a label identifying pipe contents at each valve, at each point of entry or exit where pipe passes through a wall or ceiling, at each riser and tee joint, and at intervals of 50' on long continuous runs.
- D. Apply a directional arrow at each label to show direction of flow of fluid in line. Where flow may be in both directions, provide a double headed arrow.

14. ACCEPTANCE

- A. Completed work shall be in proper working order and clean. Leave the premises and site in presentable condition, free of surplus materials and debris.
- B. Obtain and furnish to the Engineer, certificates of inspection and approval from authorities having jurisdiction.



15. PIPE CONSTRUCTION SPECIFICATION NO. 1

Service: (Above Ground) Raw Groundwater (RGW)
Filtered Groundwater (FGW)
Vent (V)
Drain (DR)
Filtered Treated Water (FTW)
Adsorber Treated Water (ATW)
Carbon Transport Water (CTW)
Carbon Defining Water (CDW)

Construction: Solvent weld

Pipe:

3/4" to 12" or larger: Schedule 80 PVC, ASTM D1785, Type 1 (normal impact), Grade 1 (high chemical resistance)

Fittings:

3/4" to 12" or larger: Schedule 80 PVC, ASTM D2467, socket type, Type 1, Grade 1 PVC (cell classification 12454B) and conform to ASTM D1784-75.

Note: Threaded PVC ASTM D2464 fittings may be provided as required to suit existing piping connections at valves, instrumentation and equipment connections.

Pipe Nipples:

1/2" to 3/4": Schedule 80 PVC, 3" to 6" long with both ends threaded or plain end.

Flanges:

Schedule 80 PVC, socket type, van stone style, male end, female pipe thread (FPT) or blind as required.

Bolt and Gasket Sets:

1/8" thick EPDM full face shore "A" durometer hardness 60 ±5, ASTM D1330, gasket with cadmium plated nuts, bolts and washers.

Unions:

1/2" to 2": PVC, socket ends.

Bonding Agents: All solvent weld PVC connections to be primed with "Purple Primer" prior to applying solvent cement.

Solvent cement, ASTM D2564, heavy bodied, fast set, high strength cement for Schedule 80 PVC. "Harrington Plastics" Part No. 306-711 or approved equal.

Valves: PVC as manufactured by "Asahi/America" or approved equal.

1-1/2" to 2": Gate valves, flanged, nonrising stem, SBR lined plug, EPDM seals, PVC body.

1/2" to 2": Ball valves, duo bloc true union, socket ends, PVC body and ball, EDPM "O" rings.

1/2" to 2": Globe valves, flanged ends, PVC body, EPDM seals. Y-Globe valves supplied with socket ends.

1-1/2": Check valves, swing type, flanged, EPDM seat and seal.

3" to 12"
or larger: Butterfly valves, 316 stainless steel shaft, body, and disc, wafer style, teflon packing and seat, infinite position lever unless otherwise specified.

Y Strainers: All PCV construction with #8 mesh (3/32" dia) strainer and socket ends.

Bleed Rings: Bleed rings shall be full port, 316 stainless steel, 1½" thick minimum.

Instrumentation Block and Bleeds: Tubing, ½" nom dia., type 316 stainless steel. Hydraulic tubing per ASTM A269 or engineer approved equal, suitable for bending or flaring.

Tube fittings shall be Crawford swagelok type or engineer approved equal.

Block and bleed valves, ½" quarter turn open/close ball valves, 316 SST body and stem, and swagelok tube fitting end



connections, Whitey and Co. Model No. SS-45S8 or engineer approved equal.

16. PIPE CONSTRUCTION SPECIFICATION NO. 2

Service: (Below Ground) Raw Groundwater (RGW)
Metering Building Under Slab

Construction:

3" and 8": Flanged 150 lb. 316 stainless steel

Pipe:

All Sizes: Schedule 40 seamless 316 stainless steel,
ASTM 312

Fittings:

3" and 8": 125 lb, stainless steel, flanged, ASTM
A 312 per ANSI B16.11

17. PIPE CONSTRUCTION SPECIFICATION NO. 3

Service: (Below Ground) Raw Groundwater (RGW)
Filter Treated Water (FTW)

Construction: Fusion weld

Pipe:

3" thru 12": HDPE PE3408 extra-high molecular weight,
ASTM D1248, Type III, Class C, Category
5, Grade P34

HDPE pipe for Raw Groundwater shall be
SDR-17 for all sizes.

HDPE pipe for Filter Treated Water shall
be SDR-21 for all sizes.

Fittings:

HDPE to match pipe. For transitions of
material (HDPE to PVC or HDPE to stainless
steel), see piping drawings.



MORRISON KNUDSEN CORPORATION

ENVIRONMENTAL SERVICES GROUP

SPEC NO.: 35-1501
W.O. NO.: 2127-22
DATE: 11/30/90
ISSUE/REV.: 0
PAGE: 22

Valves:

3/4":

Ball valve - 150# threaded, cast bronze body, 316 SS ball with teflon seals. Marpac Model BRB780-12 or approved equal.

Welding Procedure Specification

ASME IX

Page 1 of 3

Welding Procedure Specification No.		Revision		Date		Revision		Date		Revision		Date	
GT-SM88-0-1		0		8/10/89		N/A		N/A		N/A		N/A	
Supporting PQR No.(s)		8-106		N/A		N/A		N/A		N/A		N/A	
REV	Date	3	8/10/89	N/A	N/A	N/A	N/A	N/A	N/A	N/A	N/A	N/A	N/A

WELDING PROCESS(ES)

GTAW FCAW SMAW GMAW Short Circuiting Transfer
 Globular Transfer Manual Semi-automatic
 Spray Transfer Machine Automatic
 Other N/A

ASME Section I ASME Section III ASME Section VIII ANSI B31.1 ANSI B31.3
 Other N/A

JOINT DESIGN (QW-402)

Groove Compound Open Butt Backing Ring Fillet/Sockets Consumable Insert
 Nonmetallic/Nonfusing Metal Retainers Back Weld Buttering Cladding Other N/A

BASE METALS (QW-403)

P Number	Group Number (when Req'd.)	Backing Material	Diameter Range	Fillet
8 to 8	N/A to N/A	P8, when required	Unlimited	Unlimited

OR

Specification Type and Grade N/A OR Chemical Analysis and Mech. Prop. N/A
 to Specification Type and Grade to Chemical Analysis and Mech. Prop.

THICKNESS RANGE	ASME I	ASME III	ASME VIII, Div. 1	ASME IX	ANSI B31.1
	0.1875" to 8.0"	0.1875" to 8.0"	0.1875" to 8.0"	0.1875" to 8.0"	0.1875" to 8.0"
	ANSI B31.3	Other			
	0.1875" to 8.0"	N/A			

FILLER METALS (QW-404)

POSITION (QW-405)

Spec. Number	F No.	A No.	AWS Class. No.	Size of Filler	Position of Groove	
SEA-5.9	6	8	ER-XXX (See note 2)	3/32" - 1/8"	ALL	
Spec. Number	F No.	A No.	AWS Class. No.	Size of Filler	Welding Progression	
SEA-5.4	5	8	E-XXX-16 (See note 2)	3/32" - 5/32"	<input checked="" type="checkbox"/> Uphill <input type="checkbox"/> Downhill	
Insert Spec. Number	F No.	A No.	AWS Class. No. of Consumable Insert	Group No.	Shape of Insert	Size of Insert
N/A	N/A	N/A	N/A	N/A	N/A	N/A

Filler Metal Chemical Composition N/A Electrode Flux Composition N/A Supplemental Filler/Powder N/A
 Flux Composition N/A Particle Size N/A Other N/A

THICKNESS OF DEPOSITED WELD METAL QUALIFIED

Process	Max. Per Pass	Total	Process	Max. Per Pass	Total
GTAW	0.25"	0.50"	SMAW	0.375"	8.0"

PREHEAT (QW-406)

Preheat Temp. Min. 50°F Interpass Temp. Max. 350°F Preheat Maintenance Flame/Electric Monitoring Temp. Indicator Other N/A

POSTWELD HEAT TREATMENT (QW-407)

Temperature None Time at Temperature Range N/A Thickness N/A Other N/A

GAS (QW-408)

Shielding Gases) & % Composition	Flow Rate (cfh)	Backing & % Composition	Flow Rate (cfh)	Trailing & % Composition	Flow Rate (cfh)
99.9%-Argon	15-25	99.9%-Argon	5-30	None	None

Welding Procedure Specification

No. GT-SM88-0-1

ASME
IX

Page 2 of 3

ELECTRICAL CHARACTERISTICS (QW-409)

Current and Polarity	Wire Feed Speed or Amperage Range	Voltage Range	Travel Speed Range (ipm)	Heat Input Range (kJ/Inch)	Figure Number (Below)	Welding Process	Filler Metal Size (Inch)
DCSP	80-105	10-14	N/A	N/A	1, 2, 3, 4, 5, 6, 7, 8, 9	GTAW	3/32
DCSP	100-135	10-18	N/A	N/A	1, 2, 3, 4, 5, 6, 7, 8, 9	GTAW	1/8
DCRP	95-110	18-22	N/A	N/A	1, 2, 3, 4, 5, 6, 7, 8, 9	SMAW	3/32
DCRP	105-130	20-26	N/A	N/A	1, 2, 3, 4, 5, 6, 7, 8, 9	SMAW	1/8
DCRP	140-160	22-28	N/A	N/A	1, 2, 3, 4, 5, 6, 7, 8, 9	SMAW	5/32
N/A	N/A	N/A	N/A	N/A	N/A	N/A	N/A

Pulsating Current - <input checked="" type="checkbox"/> GTAW <input type="checkbox"/> GMAW <input type="checkbox"/> Yes <input checked="" type="checkbox"/> No <input type="checkbox"/> N/A	SFA/AWS - 5.12 - EWTh - 2 (2% Thoriated Tungsten) <input checked="" type="checkbox"/> Yes <input type="checkbox"/> No <input type="checkbox"/> N/A	Sizes of Tungsten <input type="checkbox"/> N/A <input checked="" type="checkbox"/> 1/16" <input checked="" type="checkbox"/> 3/32" <input checked="" type="checkbox"/> 1/8" <input type="checkbox"/> 5/32"
--	---	---

TECHNIQUE (QW-410)

String or Weave Bead	Bead Width (Max.)	Oscillation (Mech. Only)	Dwell Time (Mech. Only)	Frequency (Mech. Only)	Gas Cup Size
Both, as req'd	3/4"	N/A	N/A	N/A	4-10
Contact Tube to Work Distance	Initial & Interpass Cleaning		Vacuum Chamber	Other	
N/A	Grind, brush, file, solvent*		N/A	N/A	
Multipass or Single Pass (Per Side)	Single or Multiple Electrodes	Peening	Method of Back Gouging		
Multiple	Single	Not allowed	Thermal or mechanical		

ADDITIONAL NOTES

- *NOTES:**
- 1) This procedure is qualified for welding metals not requiring notch toughness testing.
 - 2) Suggested filler materials for both GTAW and SMAW, unless indicated otherwise: type 304 use 308 filler, 304L use 308L filler, type 316 use 316 filler, 316L use 316L filler, type 321 use 321 (GTAW) or 347 (SMAW) filler, type 347 or 348 use 347 filler.
 - 3) Clean weld with acetone, alcohol, or other approved solvent cleaner prior to welding.

FOR ADDITIONAL APPLICATIONS OF THIS WPS, SEE APPLICABLE CODE AND CONTRACT REQUIREMENTS.

Welding Procedure Specification

No. GT-SM88-0-1

ASME
IX

TYPICAL GROOVE DESIGN

Fig. 1

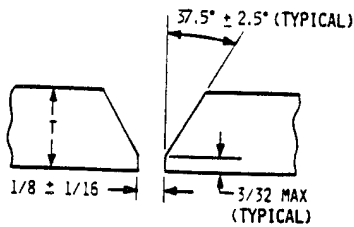

Fig. 2

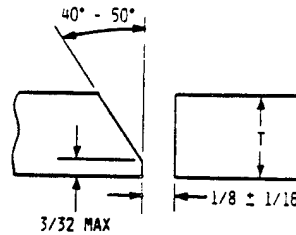

Fig. 3

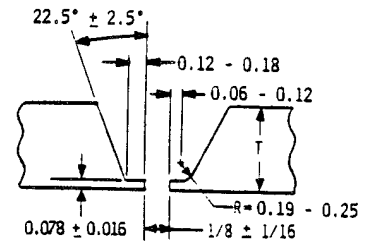

Fig. 4

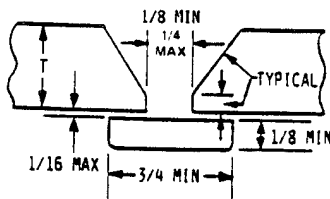

Fig. 5

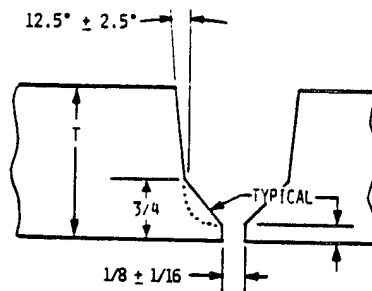
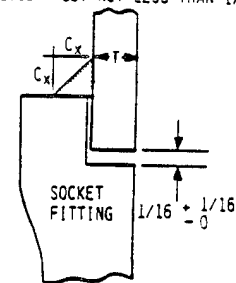

Fig. 6

ASME III & ANSI B31.1
 $C_x(\text{MIN}) = 1.09 T$ BUT NOT LESS THAN 1/8



ANSI B31.3 USE
 $C_x(\text{MIN}) = 1.25 T$ BUT NOT LESS THAN 1/8

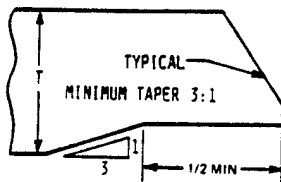

Fig. 7

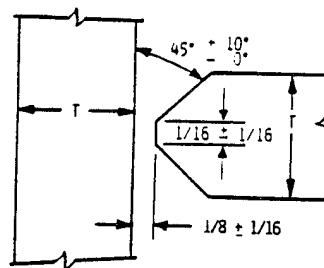

Fig. 8

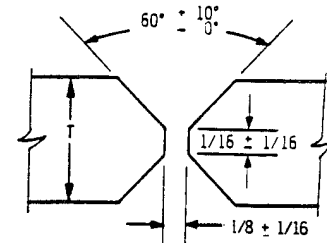
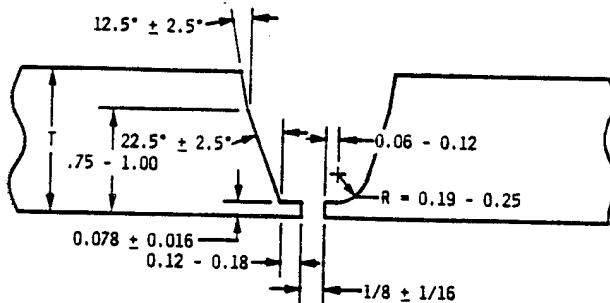

Fig. 9



Notes:

- All dimensions are in inches.
- Intersections and inside corners should be slightly rounded.
- For alternate butt welding ends see ANSI B16.25 and/or document changes by amending the WPS.
- When using consumable inserts, end preparation configurations must be compatible with the shape of the consumable insert.

Procedure Qualification Record

ASME IX

Page 1 of 2

PQR No.	8-106	Welding Process(es)	GTAW/SMAW	Type(s)	Manual
WPS No.(s)	GT-SM88-0-1	Other	N/A		

(QW-402) GROOVE DESIGN USED

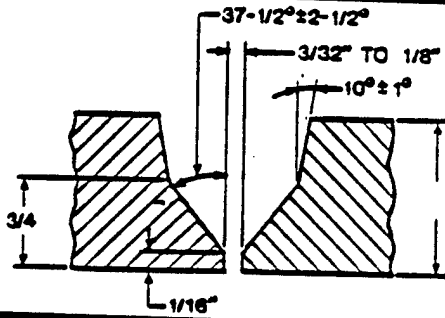

BASE METAL (QW-403)

Material Spec.	SA-240 to SA-240	Type or Grade	304L to 304L
P No. (Gp. No.)	8 Gp. 1		8 Gp. 1
Thickness Tested	1.5"	Diameter Tested (OD)	N/A
Thickness Range Qualified	0.1875"		8.0"
Other	N/A		

FILLER METAL (QW-404) AND ELECTRICAL CHARACTERISTICS (QW-409)

Bead No.	Process	Filler Metal					Current and Polarity	Amps	Volts	Travel Speed (IPM)	Heat Input (kJ/In.)	Inter Pass Temp.
		Size In.	SFA Spec.	AWS No.	A No.	F No.						
1	GTAW	1/8	5.9	ER-308L	8	6	DCSP	110	12	2.5	N/A	123°F
2-3	GTAW	1/8	5.9	ER-308L	8	6	DCSP	125	14	4.0	N/A	200°F
4-12	SMAW	1/8	5.4	E-308L-16	8	5	DCRP	120	14	5.5	N/A	300°F
Ba1	SMAW	5/32	5.4	E-308L-16	8	5	DCRP	150	22	6.0	N/A	345°F
N/A	N/A	N/A	N/A	N/A	N/A	N/A	N/A	N/A	N/A	N/A	N/A	N/A
N/A	N/A	N/A	N/A	N/A	N/A	N/A	N/A	N/A	N/A	N/A	N/A	N/A

Pulsating Current - <input checked="" type="checkbox"/> GTAW <input type="checkbox"/> GMAW	SFA/AWS - 5.12 - EWTh - 2 (2% Thoriated Tungsten)	Sizes of Tungsten	Supplemental Filler/Powder
<input type="checkbox"/> Yes <input checked="" type="checkbox"/> No <input type="checkbox"/> N/A	<input checked="" type="checkbox"/> Yes <input type="checkbox"/> No <input type="checkbox"/> N/A	<input type="checkbox"/> 1/16" <input checked="" type="checkbox"/> 1/8"	N/A

THICKNESS OF DEPOSITED WELD METAL QUALIFIED (QW-451)

Process	Max. Per Pass	Actual	Total	Position of Groove Tested
GTAW	0.125"	0.25"	0.50"	1G
SMAW	0.375"	1.25"	8.0"	Weld Progression
				<input type="checkbox"/> Uphill <input type="checkbox"/> Downhill <input checked="" type="checkbox"/> N/A

PREHEAT & INTERPASS (QW-406)

Minimum Temp.	Maximum Temp.	Monitoring	Maintenance
50°F	345°F	Contact Pyrometer	<input type="checkbox"/> Flame <input type="checkbox"/> Electric <input checked="" type="checkbox"/> N/A

POSTWELD HEAT TREATMENT (QW-407)

Temperature	Time at Temp.	Gas Cup Size	GAS (QW-408)		
None	N/A	4-8	SHIELDING	BACKING	TRAILING
		Type of Gas or Gases	Argon	Argon	N/A
Other	None	% Comp. of Gas(es)	99.9	99.9	N/A
		Flow Rate, cfh	18	5-10	N/A

TECHNIQUE (QW-410)

String or Weave Bead	Bead Width (Max)	Vacuum Chamber	Multiple or Single Pass (Per Side)	Single or Multiple Electrodes
Both	1/2"	N/A	Multiple	Single
Oscillation (Mech. Only)	Dwell Time (Mech. Only)	Frequency (Mech. Only)	Cleaning	Other
N/A	N/A	N/A	Machine, grind, brush, file	None

Procedure Qualification Record

No. 8-106

ASME
IX

Page 2 of 2

TENSILE TEST (QW-150) Conducted By
Robert L. Adrian, Koon-Hall Testing Corporation/8-12-83

LAB Test Number 3019-PG-291

SPECIMEN NUMBER	WIDTH	THICKNESS	AREA	ULTIMATE TOTAL LOAD (LB.)	ULTIMATE UNIT STRESS (PSI)	CHARACTER OF FAILURE AND LOCATION
B2809-2A	0.506"	N/A	0.2011sq.in.	17,900	89,000	WMZ
B2809-2B	0.506"	N/A	0.2011sq.in.	17,350	86,300	WMZ
B2809-5A	0.503"	N/A	0.1987sq.in.	17,600	88,600	WMZ
B2809-5B	0.505"	N/A	0.2003sq.in.	17,600	87,900	WMZ

GUIDED BEND TESTS (QW-160) Conducted By
Robert L. Adrian, Koon-Hall Testing Corporation/8-12-83

LAB Test Number 3019-PG-291

TYPE AND FIGURE NUMBER	RESULT	TYPE AND FIGURE NUMBER	RESULT
Side; QW-462.2	ACCEPTABLE	Side; QW-462.2	ACCEPTABLE
Side; QW-462.2	ACCEPTABLE	Side; QW-462.2	ACCEPTABLE

TOUGHNESS TESTS (QW-170) Conducted By
N/A

LAB Test Number N/A

SPECIMEN NO.	NOTCH LOCATION	NOTCH TYPE	TEST TEMP.	IMPACT VALUES (FOOT POUNDS)	LATERAL EXPANSION		DROP WEIGHT	
					% SHEAR	MILS	BREAK	NO BREAK
1- N/A	N/A	N/A	N/A °F	N/A	N/A	N/A	N/A	N/A
2- N/A	N/A	N/A	N/A °F	N/A	N/A	N/A	N/A	N/A
3- N/A	N/A	N/A	N/A °F	N/A	N/A	N/A	N/A	N/A
1- N/A	N/A	N/A	N/A °F	N/A	N/A	N/A	N/A	N/A
2- N/A	N/A	N/A	N/A °F	N/A	N/A	N/A	N/A	N/A
3- N/A	N/A	N/A	N/A °F	N/A	N/A	N/A	N/A	N/A
1- N/A	N/A	N/A	N/A °F	N/A	N/A	N/A	N/A	N/A
2- N/A	N/A	N/A	N/A °F	N/A	N/A	N/A	N/A	N/A
3- N/A	N/A	N/A	N/A °F	N/A	N/A	N/A	N/A	N/A

Heat Affected Zone Ave. N/A

Weld Metal Zone Ave. N/A

Base Metal Zone Ave. N/A

FILLET WELD TEST (QW-180) Conducted By
N/A

LAB Test Number N/A

Result - Satisfactory N/A	Penetration into Parent Metal N/A	Type and Character of Failure N/A
Macro-results N/A	Other N/A	

OTHER TEST Conducted By
Robert L. Adrian, Koon-Hall Testing Corporation/8-12-83

LAB Test Number 3019-PG-291

RT N/A	UT N/A	Deposit Analysis N/A
-----------	-----------	-------------------------

Other
ASTM A-262 Practice A: WMZ, BMZ, HAZ = Acceptable / WRC Delta Ferrite: 17.0 FN (avg.)

Welder's Name: Frank Shawler

Stamp Number: 106

We certify that the statements in this record are correct and that the welds were prepared, welded and tested in accordance with the requirements of Section IX of the ASME code.

REV	3	N/A	N/A	N/A	MK-Ferguson Company	By <i>Alain Artajet</i>	Date 8/10/89
Checked	ASA	N/A	N/A	N/A			
Date	8/10/89	N/A	N/A	N/A			

Detail of record of tests are illustrative only and may be modified to conform to the type and number of tests required by the code.



SPECIFICATION 35-1510

PIPING INSULATION

CLIENT: SHELL OIL COMPANY

PROJECT: ROCKY MOUNTAIN ARSENAL REMEDIATION PROJECT

INTERIM RESPONSE ACTION FINAL DETAILED DESIGN

RAIL CLASSIFICATION YARD/MOTOR POOL AREA IRA

LOCATION: ROCKY MOUNTAIN ARSENAL, COMMERCE CITY, CO



CONTENTS

PAGE

1.	SCOPE	3
2.	RELATED WORK	3
3.	REFERENCE STANDARDS	3
4.	CONTRACT PROPOSAL	3
5.	SUBSTITUTION OF MATERIALS	3
6.	GENERAL SPECIFICATIONS FOR INSULATION	4
	INSULATION DATA SHEET CLASS B	8
	INSULATION DATA SHEET CLASS D	9



SPECIFICATION 35-1510

PIPING INSULATION

1. SCOPE

A. This specification and other Contract Documents cover the furnishing and installing of piping insulation as required by the applicable drawings and as specified herein.

2. RELATED WORK

A. The following related work is covered in other specifications:

- 1) Pipe sleeves (Specification 35-1501)
- 2) Pipe saddles installed in place (Specification 35-1501)
- 3) Electrical Work (Heat Tracing) (Specification 37-1601)

3. REFERENCE STANDARDS

A. Standards of the following organizations shall be followed where applicable:

- 1) ASTM - American Society for Testing and Materials
- 2) OSHA - Occupational Safety and Health Administration

4. CONTRACT PROPOSAL

A. Proposal shall be based on the specified insulation completely installed in place.

B. When requested on Insulation Data Sheets, ignition characteristics of insulation shall be furnished with a statement regarding compliance with local codes at the site.



5. SUBSTITUTION OF MATERIALS

- A. It is not intended that this specification prohibit the use of materials by manufacturers other than those specified. All requests for substitutions must be made in writing.
- B. All substitutions are subject to prior approval by the Engineer and will receive consideration if in his opinion, the following conditions have been satisfied:
- 1) Proposed insulation will be furnished in thermally equivalent thickness to those specified herein.
 - 2) Alternates for accessory materials shall be suitable for the service and exposure conditions and shall be compatible with the selected insulation at the temperatures involved.
 - 3) As with specified materials, substitute materials shall satisfy health and safety requirements of the governing agencies.
- C. Bidder shall provide the following information with his initial proposal:
- 1) Exact names of products and their manufacturers.
 - 2) Sum to be deducted from (or added to) his proposal if alternate products are used.
 - 3) Delivery times of alternate versus specified products.
 - 4) Descriptive and technical data sufficient for evaluation.

6. GENERAL SPECIFICATIONS FOR INSULATION

A. General Requirements:

- 1) After piping requiring insulation has been erected and/or installed and tested, exterior surfaces shall be thoroughly cleaned by the subcontractor of rust, loose mill scale, oil, dirt and other foreign matter prior to application of insulation.
- 2) Apply insulation with surfaces dry and at the temperature limitations established by the insulation and accessory manufacturers.



- 3) The table, "PIPING INSULATION," indicates acceptable insulation and thickness required for specific items, and final surface finishes to be used.
- 4) Carefully examine insulation applied to surfaces subject to sweating, as work progresses and after completion, to assure vapor barrier is complete and unbroken throughout.
- 5) Insulation, adhesives, mastics, coatings, etc., shall be applied in accordance with the manufacturer's recommendations.
- 6) All insulating materials stored on the project site, and incomplete insulation work shall be adequately protected from weather. If insulation becomes wet, it shall be removed from the project site.
- 7) For insulation purposes, all components of the pipe line are to be insulated in accordance with the requirements of the adjoining piping.
- 8) Any conditions of leaking pipe shall be brought to the attention of the Field Engineer, who shall see that these conditions are corrected. Insulation shall not be applied until the corrections are made.
- 10) No insulation shall be applied until after testing and approval by the Field Engineer or governing authority.
- 11) Coordinate with electrical subcontractor for insulation application on piping requiring electric heat tracing.

B. Application of Insulation:

- 1) Pipe lines with hangers, saddles, etc., shall be set in permanent locations before insulation is applied. If necessary, restore pipe and hangers to original locations and alignment after insulation is installed.
- 2) Where piping is supported by hangers installed outside insulation, use galvanized steel half round shields with calcium silicate inserts of sufficient thickness to prevent crushing insulation, as follows:



<u>Pipe Size</u>	<u>Shield Thickness</u>	<u>Shield Length</u>
3" and Smaller	18 gauge	12"
4" and 8"	16 gauge	18"

- 3) Neatly bevel exposed ends of insulation down to pipe with insulating cement or vapor seal cement, prior to insulation of flanges, with sufficient clearance for removal or tightening of bolts at flanged connections. Apply flange insulation separately after joints are proven tight and pipe insulation is completed.
- 4) Workmanship shall be first class in every respect.
- 5) Keep pipe joints uninsulated until piping system or systems are tested and approved.



PIPING INSULATION TABLE

SERVICE	SYMBOL	SURFACE TEMP. - °F	CLASS	PIPE SIZES	THICKNESS
Raw Groundwater Above Ground	RGW	--	B	1½" - 8"	1" - 1½"
Raw Groundwater Below Grade (From 1'0" Above Grade to 3'0" Below Grade)	RGW	--	D	6" - 8"	1½"
Filter Treated Water Below Grade (From 1'0" Above Grade to 3'0" Below Grade)	FTW	--	D	6" - 12"	1½" - 2"

NOTES:



INSULATION DATA SHEET

CLASS B

Temperature Range: -60°F to +220°F

Service: Outdoors above grade and/or in enclosure vent, piping insulation shall be as required for extremely corrosive environments and severe climatic conditions such as high ultraviolet concentrations, high and low temperatures, high altitude, high winds, and desert areas.

Materials:

Pipe: 1/2" through 1-1/2" shall have 1" thick applied insulation. Sizes 2" and larger shall have 1-1/2" thick applied insulation. Insulation shall be "Thermazip" TMZ 475 jacketed polyurethane foam as manufactured by "Accessible Products Company" or approved equal.

Fittings: Fittings shall be insulated with "Thermazip" preformed insulated fitting covers to match pipe line size.

Installation: Insulation shall be cut to proper length, wrapped around pipe, and the trac locked into position and permanently sealed with fastener weld. All butt joints shall be finished with 400 series butt strips and sealants. All fitting covers shall be sealed with sealant, then taped in place using pressure sensitive tape. Materials shall be as manufactured by "Accessible Products Company" or approved equal. All installation is to be performed in compliance with the directions of the manufacturer.



INSULATION DATA SHEET

CLASS D

Temperature Range: -450° F to +900° F

Service: Outdoors below grade from a depth of 0' to 3' as required for severe climatic conditions such as high and low temperatures, high altitude, and wet conditions.

1. MATERIAL

- A. Cellular glass, rigid preformed sectional units for piping, vessels, equipment, storage tanks as manufactured by: Pittsburgh Corning Corporation--FOAMGLAS\ Insulation.
- B. Specification: ASTM C552-86.

2. ACCESSORIES

- A. Joint Sealant: Pittsburgh Corning "PITTSEAL\ 444" or Foster "95-50".
- B. Tape: 3M "Scotch Brand Filament Tape" 1 inch wide.
- C. Bands: 1/2" x 0.020", stainless steel for use over aluminum or stainless steel jacketing.
- D. Aluminum Weatherproof Jacketing: 0.016" thick smooth surface material having factory applied 1 mil polykraft moisture barrier; Johns-Manville "Metal-On," Childers "Lock On" or Insul-Coustic "Alcor-Jac."
- E. Aluminum Type 1100 Alloy Weatherproof Fitting and Valve Covers: Childers, 0.024" thick smooth material having factory applied acrylic moisture barrier; Childers "Ell-Jacs" and "Valve Jacs".
- F. Lap Adhesive: Foster "95-44" for use with aluminum or stainless steel jacket.
- G. Weather Barrier Mastic: Pittsburgh Corning "Pittcote\ 400" vinyl acrylic latex or approved equal.
- H. Vapor Barrier Mastic: Pittsburgh Corning "Pittcote\ 300" asphalt cutback or approved equal.
- I. Reinforcing Fabric: Pittsburgh Corning "PC 79" synthetic mesh fabric.



J. Insulation Adhesive: Pittsburgh Corning "PC 88" two-part asphaltic adhesive.

3. APPLICATION OF INSULATION

A. Insulation shall be applied according to Paragraph 6, "General Specifications for Insulation," and as specified herein.

1) Below Ground (From 1'0" Above Grade to 3'0" Below Grade)

a) Pipe Runs:

- (1) Tightly butt together on pipes, sections of pipe insulation; draw flaps of vapor barrier jackets tightly over joints and seal the longitudinal seams neatly in place with the pressure sealing lap adhesive. Do not use staple fasteners. Additionally secure the covering with bands of stainless steel on maximum 12" centers, starting 6" from the ends of each section.
- (2) Seal end joints with 4" wide strips of vapor barrier jackets, with the pressure sealing lap adhesive. Seal off ends of pipe covering units at flanges, valves, fittings and with vapor barrier mastic.
- (3) If insulation units are not furnished with factory applied jackets, use wire loops or bands to secure insulation in place. Wire loops shall be tightly twisted, bent over and embedded into the insulation leaving no sharp protrusions. Then add either vapor barrier paper or vapor barrier mastic.

b) Valves, Fittings and Flanges: Insulation shall be molded glass fiber pipe fitting covers of the same thickness as the adjacent pipe covering. Covers shall be secured by means of wire loops with ends twisted together and embedded into the insulation so as to leave no projections. Coat with vapor barrier mastic reinforced with glass cloth.



4. SURFACE FINISHES

- A. Finishes to be applied to insulation surfaces specified above shall conform to the following:

Aluminum waterproof jacketing



SPECIFICATION 35-1511

MANHOLES

CLIENT: SHELL OIL COMPANY

PROJECT: ROCKY MOUNTAIN ARSENAL REMEDIATION PROJECT

INTERIM RESPONSE ACTION FINAL DETAILED DESIGN

RAIL CLASSIFICATION YARD/MOTOR POOL AREA IRA

LOCATION: ROCKY MOUNTAIN ARSENAL, COMMERCE CITY, CO



	<u>CONTENTS</u>	<u>PAGE</u>
1.	SCOPE	3
2.	RELATED WORK	3
3.	REFERENCE STANDARDS	3
4.	MATERIALS	3
5.	INSTALLATION	4



SPECIFICATION 35-1511

MANHOLES

1. SCOPE

- A. This specification covers the furnishing and installing of precast concrete manholes that shall be located to serve the groundwater intercept system for the Rail Classification Yard/Motor Pool Area IRA.
- B. Manhole locations and details are as shown on the drawings.

2. RELATED WORK

- A. Related work is covered under other specifications:
 - 1) Site Preparation, Grading, Excavating, and Backfilling (Specification 34-0212)
 - 2) Cast-In-Place Concrete (Specification 34-0301)
 - 3) General Specifications for Piping (Specification 35-1501)

3. REFERENCE STANDARDS

- A. Organizations whose standards are referenced herein include the following:
 - 1) ASTM - American Society for Testing and Materials
 - 2) CDOH - Colorado Department of Highways Standard Specifications for Road and Bridge Construction
- B. Any reference to the above standards shall be the edition in effect as of the date of this specification, unless stated otherwise.

4. MATERIALS

- A. Aluminum Castings: ASTM No. B 179-65 Alloy 319.0, Alloy A 332.0.
- B. Grout: Flexible, waterproof, nonmetallic, noncorrosive joint sealant; AV-220 Grout (Avanti); or as approved by the Engineer.



- C. Precast Concrete Units: ASTM C478. Each manhole shall have pre-formed penetrations to allow placement of piping through manhole sidewalls.
- D. Gravel: Colorado Department of Highways Standard Specifications for Road and Bridge Construction, Section 703; Aggregate No. 6, 3/4" to 3/8" coarse aggregate.
- E. Manhole Steps: M.A. Industries Inc., Style PS-2-PF, copolymer polypropylene plastic with 1/2" Grade 60 steel reinforcement; or as approved by the Engineer.

5. INSTALLATION

A. Manholes:

- 1) Excavate earth to a minimum of 8" below required manhole base elevation, machine-compact the ground surface, then fill and level gravel up to the required manhole base elevation.
- 2) Set the manhole base portion atop the leveled gravel fill on the pre-established centerline.
- 3) In Manhole Nos. 4-8 construct the cast-in place concrete saddles within the manholes and set the pipeline through the manhole wall and saddle. The contact between the saddle and manhole floor should be roughed slightly, then coated with an Engineer-approved bonding agent. Concrete shall be placed to firmly support the 8-inch tee. Prefabricated or field-constructed pipe supports should also be placed as required in Manhole Nos. 1-3.
- 4) Join the wall and top sections to the cylindrical base with joint sealant. Where joint sealant is in contact with the pipeline, the pipe surface should be roughed slightly.
- 5) Install catwalk framework and fiberglass grating (Dura-deck or Engineer-approved equal) where shown on the drawings.



SPECIFICATION 36-0000

EQUIPMENT LIST

CLIENT: SHELL OIL COMPANY

PROJECT: ROCKY MOUNTAIN ARSENAL REMEDIATION PROJECT

INTERIM RESPONSE ACTION FINAL DETAILED DESIGN

RAIL CLASSIFICATION YARD/MOTOR POOL AREA IRA

LOCATION: ROCKY MOUNTAIN ARSENAL, COMMERCE CITY, CO

EQUIPMENT LIST

W.O. NO.: 2127-22
 PROJECT: RMA
 CLIENT: Shell Oil Co.
 DEPT/DIST. NO.: 36-Mechanical

DATE: 01/11/91
 PREPARED BY: L. Morrison
 CHECKED BY: AML
 REVISION: 1

RAIL CLASSIFICATION YARD/
 MOTOR POOL AREA IRA

EQUIPMENT NO.	DESCRIPTION	QTY	HP/EQUIV.	SPEC.NO.	REF. DWG.	REMARKS
PU-301 thru PU-305	Submersible well pump Cap. 61 gpm at 129' TDH. max. with 3 hp motor	5	3	36-1831	38-005 34-006	For Wells RYDW1 thru RYDW5
PU-306 PU-307	Submersible well pump Cap. 83 gpm at 160' TDH. max. with 5 hp motor	2	5	36-1831	38-005 34-006	For Wells RYDW6 and RYDW7
PU-401 PU-402	Submersible well pump Cap. 58 gpm at 120' TDH. max. with 3 hp motor	2	3	36-1831	38-005 34-006	For Wells MPDW1 and MPDW2
P-511	Submersible well pump Cap. 140 gpm at 110' TDH max with 5 hp motor	1	5	36-1831	38-006 34-010	For Well ISEW 39
P-512 thru P-514	Submersible well pump Cap. 225 gpm at 135' TDH max with 10 hp motor	3	10	36-1831	38-006 34-010	For Wells ISEW 40 through ISEW 42
P-104 P-105	Vertical turbine pump Cap. 700 gpm at 161' TDH with 40 hp motor	2	40	36-1823	38-002 36-001	One (1) on-line one (1) stand-by for new sump at Irondale Plant

EQUIPMENT LIST

W.O. NO.: 2127-22
 PROJECT: RMA
 CLIENT: Shell Oil Co.
 DEPT/DIST. NO.: 36-Mechanical

RAIL CLASSIFICATION YARD/
MOTOR POOL AREA IRA

DATE: 01/11/91
 PREPARED BY: L. Morrison
 CHECKED BY: AML
 REVISION: 1

EQUIPMENT NO.	DESCRIPTION	QTY	HP/EQUIV.	SPEC.NO.	REF. DWG.	REMARKS
P-501 thru P-503	Vertical turbine pump Cap. 1000 gpm at 50' TDH with 20 hp motor	3	20	36-1823	38-007 36-002	Two (2) on line one (1) stand-by for new effluent sump at Irondale Plant.
S-107A S-107B	Bag pre-filter Capacity: 1000 gpm w/ 10 micron rated bags	2		36-2614	38-002 36-001	Raw groundwater pre-filters
S-108A S-108B	Bag first- stage post-filter Capacity: 1000 gpm w/ 10 micron rated bags	2		36-2614	38-003 36-001	Adsorber effluent filtration

EQUIPMENT LIST

W.O. NO.: 2127-22
 PROJECT: RMA
 CLIENT: Shell Oil Co.
 DEPT/DIST. NO.: 36-Mechanical

DATE: 11/30/90
 PREPARED BY: L. Morrison
 CHECKED BY: AML
 REVISION: 0

EQUIPMENT NO.	DESCRIPTION	QTY	HP/EQUIV.	SPEC.NO.	REF. DWG.	REMARKS
S-109	Bag second-stage post-filter Capacity: 1600 gpm w/ 5 micron rated bags	1		36-2614	38-003 36-001	Adsorber effluent filtration by "Filter Specialist Inc." Model No. FS-2000-8 to match existing units
--	Chain wheel operator to replace existing hand operator on 6"-150 lb wafer butterfly valve by Colonia Engr. Inc.; Thermoplastic valve, w/8' of operating chain	4	--	--	35-002	For existing Butterfly valves at Carson Adsorber V-102 and V-101
--	Chain wheel operator to replace existing hand operator on 6"-150 lb wafer butterfly valve by Plastics Inc., model #7120779 w/8" of operating chain	1	--	--	35-002	For existing Butterfly valves at Carbon Adsorber V-103



SPECIFICATION 36-0102

GENERAL SPECIFICATIONS FOR EQUIPMENT

CLIENT: SHELL OIL COMPANY

PROJECT: ROCKY MOUNTAIN ARSENAL REMEDIATION PROJECT

INTERIM RESPONSE ACTION FINAL DETAILED DESIGN

RAIL CLASSIFICATION YARD/MOTOR POOL AREA IRA

LOCATION: ROCKY MOUNTAIN ARSENAL, COMMERCE CITY, CO



<u>CONTENTS</u>	<u>PAGE</u>
1. SCOPE	3
2. DEFINITIONS	3
3. LAWS AND ORDINANCES	3
4. REFERENCE STANDARDS	4
5. DESIGN REQUIREMENTS	4
6. SITE CONDITIONS	6
7. MANUFACTURERS' DRAWINGS AND DATA	6
8. GENERAL PROCEDURES	7
9. ELECTRICAL REQUIREMENTS	8
10. SHOP PAINTING	9



SPECIFICATION 36-0102

GENERAL SPECIFICATIONS FOR EQUIPMENT

1. SCOPE

A. This specification is intended to cover general requirements for all items of equipment furnished for this project. These requirements apply except as they may be modified by statements in project specifications covering specific equipment, the drawings and other documents.

2. DEFINITIONS

A. The term "Owner", as used herein and in attached specifications, shall mean the firm named in the project title for whom the facility is being constructed.

B. The term "Engineer", as used herein and in attached specifications, shall mean the "Owner's" appointed representative authorized to act on technical matters as specified.

C. The term "Contractor", as used herein and in attached specifications, shall mean the "Contractor" responsible for the installation and testing of that portion of work applicable to the specification where it is used.

D. The term "Bidder", as used herein and in attached specifications, shall mean the potential supplier who is offering a proposal.

E. The term "Supplier", as used herein and in attached specifications, shall mean the company contracted to furnish materials or equipment for the installation by the Contractor.

F. The term "Manufacturer", as used herein and in attached specifications, shall mean the company who fabricates and assembles materials and equipment for the installation by the Contractor.

3. LAWS AND ORDINANCES

A. Equipment materials and work required under the project specifications which reference this specification, shall conform to applicable provisions of the Federal laws



including, but not limited to, the following with the latest amendments thereto:

- 1) Part 1926 - Construction Safety Standards, Chapter XVII, Subparts A through X, Code of Federal Regulations.
- 2) Part 1910 - Occupational Safety and Health Standards, Chapter XVII of Title 29, Code of Federal Regulations.

B. Except as otherwise directed, Supplier or Contractor shall secure and pay for all permits, inspections and certifications required for his work and arrange for necessary approvals by the governing authorities.

4. REFERENCE STANDARDS

A. Organizational standards referred to in the project specifications shall be as published under the date and/or edition specified therein, or, if not dated, according to the editions and supplements in use on the date of the specification and currently available. Where a standard requires choices by the Bidder, selections shall be based upon the requirements of the standard and, together with the appropriate issue dates, shall be cited in his proposal.

B. Furnish all necessary inspection reports, approvals, certificates, and labels, stamps or nameplates required by the specific reference standards cited in the individual specifications for materials, and equipment or component parts.

5. DESIGN REQUIREMENTS

A. Design requirements specified in individual equipment specifications and their Data Sheets are intended to identify particular features of design having significance to the Engineer. They are not intended to establish design, structural arrangement of performance features to such extent that the omission of proper or conventional features may be implied in any manner.

- 1) At time of bidding, unless otherwise specified in the project specifications, Bidder may, on an "approved equal" or substitution basis, propose other equipment, which he considers comparable with or superior to the specified items. In the absence of



a listing of such equipment, it will be assumed that the Bidder intends to furnish the items as specified.

- 2) Bidder shall provide sufficient information and data necessary for full evaluation of any equipment proposed on an "approved equal" or substitution basis. As a minimum, information shall include a complete description, physical dimension, manufacturer's name and model number, price, time for delivery, and a specific listing of any characteristics which differ from those specified and/or could require engineering changes to equipment, buildings, structures and services.

B. Approved Equals:

- 1) Evaluation of "approved equals" or substitutions, of the service intended, and final acceptance thereof shall be in writing by the Engineer. The successful Bidder shall be liable for the cost of any subsequent engineering changes which are clearly attributable to negligence on the part of the Bidder to finish proper information with his proposal.
- 2) Manufacturers' names and model numbers are intended only to indicate the type and quality of material and equipment required. Except as otherwise specified, equivalent products by other manufacturers will be acceptable if approved in writing by the Engineer.
- 3) The statement, "no substitutions permitted," requires mandatory use of the specified product.

- C. Conformance to Laws and Ordinances: If any revisions to drawings or specifications as issued are required to make equipment, materials or work conform to national, state and local laws, codes, ordinances and regulations, Bidder shall give notice when submitting his bid, and include a statement listing the additions to or deductions from the bid price required by the revisions.



6. SITE CONDITIONS

- 1) Altitude: Approximately 5,215 feet MSL
- 2) Ambient Conditions:
 - a) Maximum Temperature: 110°F DB
 - b) Minimum Temperature: -20°F DB
- 3) Design Loads (where applicable):
 - a) Design loads shall be in accordance with the latest edition of the Uniform Building Code (UBC).
 - b) Roof Live Loads:
 - (1) Maximum live (snow) load; uniform 30 psf.
 - (2) Rain-on-snow surcharge load = N/A.
 - c) Wind and Seismic Loads: Every building, equipment support or structure and every portion thereof shall be designed and constructed to resist stresses produced by lateral forces as provided in the wind and earthquake sections of the Uniform Building Code (latest edition).
 - (1) Basic Wind Speed: 85 mph, Exposure "C".
 - (2) Seismic Zone No. 1.

7. MANUFACTURERS' DRAWINGS AND DATA

- A. Approval Drawings and Data: Submit in the kinds and quantities indicated in the Specifications and Contract Documents. All drawings and data submitted shall bear the stamp of approval of the supplier as evidence that the drawings and data have been checked by him. Purchase order number or subcontract number must be shown on all copies of vendor data submittals.
- B. Certified Drawings and Data: After Engineer's final approval, furnish for record and distribution drawings and data in the kind and quantities indicated in the Specifications, certified as representative of the equipment furnished. Purchase order number must be shown on all copies of vendor data submittals.



- C. Procedure: Clearly identify all drawings and data with purchase order and equipment numbers. Transmit them according to the instructions given in the applicable purchase order or contract and addressed to the attention of the individual mentioned therein.
- D. Supplier's Responsibility: Although fabrication and shipment before final approval shall be at Supplier's risk, Engineer's approval will be for basic design and arrangement only. Supplier shall be responsible for correctness of dimensions, proper design of details and proper functioning of equipment in compliance with specified requirements.
- E. Required Information: Drawings and data shall show complete information pertinent to the equipment involved, including dimensional drawings, assembly diagrams, details of fabrication and installation, Data Sheets, performance curves, electrical wiring and connection diagrams, and motor lists. See Electrical Requirements paragraph herein.

8. GENERAL PROCEDURES

A. Shop Inspection and Tests:

- 1) Owner and Engineer reserve the right to enter Manufacturers' and Manufacturers' Vendors' plants at reasonable time to inspect workmanship, materials and equipment, and observe tests prior to shipment.
- 2) Should inspection of materials and workmanship, and witnessing of appropriate tests, by the Engineer and Owner reveal noncompliance with these specifications, the Manufacturer will be held responsible to make all necessary corrections for compliance at his expense and to the complete satisfaction of the Engineer.

B. Preparations for Shipment

- 1) Protecting Machined Surfaces: Apply a rust preventive on machined ferrous metal surfaces such as flanges and shafts. Material shall be a type which is easily removable with solvent during equipment installation, such as Rust Veto 342 or other appropriate formulation of E. F. Houghton & Co., Philadelphia, PA.



- 2) Covering Openings: Close pipe connections and other openings with easily removable plugs, stoppers or flange covers.
- 3) Packing: Adequately protect items shipped, depending on their type and nature. Take special care in packing instruments and other delicate parts.
- 4) Identifying: Mark each shipping container with purchase order, work order and equipment numbers. Small items may be identified with waterproof tags securely attached. Identify motors which are shipped separately by tagging with the equipment number of the driven equipment followed by the letter M.
- 5) Packing List shall be furnished with each shipment.

9. ELECTRICAL REQUIREMENTS

A. Scope:

- 1) Supplier shall be responsible for design of electrical equipment and devices in conjunction with required mechanical equipment, including motors, integral conduit and wiring, and lighting fixtures, as applicable. Manufacturers' drawings and data submitted shall state complete information for all such electrical equipment and devices, and shall conform to the latest issue of the National Electrical Code.
- 2) Motors shall be furnished by the Supplier, unless otherwise specified or instructed. Mount motors on equipment in the shop, or ship separately for mounting at job site, according to terms of the purchase order or contract covering equipment involved.
- 3) Motor starters and pushbutton stations are not included, unless otherwise stated in project specifications.
- 4) Unless specifically excluded, Supplier shall furnish all necessary control power transformers and associated switches and wiring for equipment operation.
- 5) Wiring required for connection to external equipment or devices shall be identified by separate numbers



and terminated at a properly marked terminal board or cabinet.

- 6) When electrical equipment is furnished by others to the supplier for installation, he shall test and be responsible for its proper operation.
- 7) All devices and material supplied shall be UL listed, where applicable.
- 8) Electrical connection diagrams shall consist of internal wiring diagrams, elementary (schematic) diagrams, and interconnection diagrams, including connections to devices affecting equipment even though devices are furnished by others. Schematic diagrams shall conform to Joint Industry Council standards.
- 9) Motor shall be supplied with stamped stainless steel nameplates providing the following information: name or manufacturer, catalog number, voltage, phase, r/min, frame number, type enclosure, service factor and insulation type.

B. Electrical Characteristics: Instrumentation, equipment and materials shall be guaranteed for the following primary electrical services. Electrical characteristics listed in other specifications are nominal unless they specifically state exceptions to and precedence over this specification.

- 1) 208Y/120 volts, three-phase, four-wire, 60 Hertz, grounded neutral.
- 2) 480Y/277 volts, three-phase, four-wire, 60 Hertz, grounded neutral.

10. SHOP PAINTING

- A. Supplier or Manufacturer shall paint all ferrous metal surfaces before shipping equipment, except machined and lubricated surfaces (see Preparations for Shipment, paragraph 7.B herein for machined surface protection). Standard colors will be acceptable unless otherwise specified or instructed by the Engineer.
- B. Thoroughly clean and prepare surfaces to be painted. Remove dirt, oil, grease, loose mill scale, rust, weld spatter and other foreign matter.



- C. Apply one uniform coat of rust inhibiting primer on such items as supports, brackets, tanks and piping materials.
- D. Apply one coat of primer and one coat of enamel on equipment items normally finish painted, such as machinery housings, motors and reducers. Use appropriate heat resistant paint on hot surfaces.
- E. Apply baked enamel on outside and inside surfaces of panels and cubicles.
- F. When special coating materials are required, instructions for surface preparation and subsequent painting will be given in the project specifications.



SPECIFICATION 36-1823

VERTICAL TURBINE PUMPS

CLIENT: SHELL OIL COMPANY

PROJECT: ROCKY MOUNTAIN ARSENAL REMEDIATION PROJECT

INTERIM RESPONSE ACTION FINAL DETAILED DESIGN

RAIL CLASSIFICATION YARD/MOTOR POOL AREA IRA

LOCATION: ROCKY MOUNTAIN ARSENAL, COMMERCE CITY, CO



<u>CONTENTS</u>	<u>PAGE</u>
1. SCOPE	3
2. RELATED WORK	3
3. REFERENCE STANDARDS	3
4. GENERAL	4
5. DETAIL REQUIREMENTS	4
6. VENDOR DATA AND DRAWING SUBMITTALS	6
7. PUMP DATA SHEETS	7
8. MOTOR DATA SHEETS	11



SPECIFICATION SECTION 36-1823

VERTICAL TURBINE PUMPS

1. SCOPE

A. This specification, Specification 36-0102, "GENERAL SPECIFICATIONS FOR EQUIPMENT", and other Contract Documents cover the furnishing of vertical turbine pumps as specified herein and on the drawings and attached Data Sheets.

2. RELATED WORK

A. The following items of related work are specified in other sections of the specifications:

- 1) Pump discharge piping beyond pump discharge flange (Specification 35-1501)
- 2) Electrical installation and field wiring (Specification 37-1601)
- 3) General Specifications for Equipment (Specification 36-0102)

3. REFERENCE STANDARDS

A. Manufactures standard product, embodying the design features and requirements specified herein and complying with the accepted standards of the industry, will be considered acceptable.

B. Organizations whose standards are referenced herein include the following:

- 1) AWWA - American Water Works Association
- 2) AFBMA - Anti-Friction Bearing Manufacturers Association
- 3) ANSI - American National Standards Institute
- 4) ASTM - American Society for Testing and Materials
- 5) NEMA - National Electrical Manufacturers Association



6) NFPA - National Fire Protection Association

4. GENERAL

A. Description:

- 1) Pumps shall be of the vertical turbine, wet well type, each complete with drive motor and with flanged discharge and provisions for bearing lubrication.
- 2) Pump capacity, operating conditions, well depth and size, and method of pump lubrication, shall be as specified on the drawings and attached Data Sheets.

5. DETAIL REQUIREMENTS

A. Performance:

- 1) Each pump shall operate under the conditions specified with impeller diameter not exceeding 90% of the maximum diameter which can satisfactorily operate in pump casing. It shall operate stably without pulsation, vibration or internal recirculation and with characteristics at design point such that variation of 10% in head results in not more than a 15% variation in gpm.
- 2) Pumps shall operate smoothly at all speeds by statically and dynamically balancing the rotating components.
- 3) Supplier shall guarantee capacity, head, efficiency, and horsepower at design conditions.

B. Pump Assembly:

- 1) Pump Bowls shall be of cast steel or close grain cast iron having minimum tensile strength of 30,000 pounds per square inch, free from blow holes, sand holes and all other faults. They shall be accurately machined, fitted to close dimensions, and shall be equipped with wear rings and renewable type water lubricated sleeves. Each bowl shall have an impeller seal ring to prevent slippage of water between bowl and impeller.
- 2) Impellers shall be of bronze, accurately machined, mechanically balanced and securely fastened and locked to pump shaft in a manner that will prevent



loosening. Type, number and size of impellers shall be according to manufacturer's standard practice to suit pump capacity and pressure given in data sheets. All impellers shall be equipped with wearing rings.

- 3) Impeller Shafts shall be of 416 stainless steel and shall be supported by water lubricated type bearings.

C. Suction Head: The suction mouth shall be of such design to reduce vortexes at pump entrance, provide installation with least possible submergence and shall be equipped with strainers.

D. Discharge Column Assemblies:

- 1) The Column Pipes shall be flanged with size and material according to manufacturer's standard practice suitable for pumps as specified on data sheets and sketches. The column assemblies shall have bronze guides fitted into the column couplings. Each guide shall contain a water lubricated type bearing to support the line shaft.

- 2) Line Shafts: The line shafting shall be turned, ground and polished precision shafting of ample size to operate the pump without distortion or vibration. A noncorrosive journal shall be placed on each shaft at the bearing point. The journal shall consist of stainless steel or monel sleeve swaged into a shaft recess with the outside diameter substantially flush with the shaft O.D. (recess not to be deeper than diameter corresponding to the root diameter of shaft threads).

E. Discharge Heads shall be fabricated steel or castiron with flanged outlets of sizes as specified on data sheets and shall be equipped with packing box of such design to minimize leakage.

F. A level control shall be provided for pump control and high level alarm. Level sensor and alarm shall be provided by others.

G. Drives: Motor and pump heads shall be of unit construction. The thrust bearings shall have the capacity to carry the weight of all rotating parts plus the hydraulic thrust of pump impeller.



6. VENDOR DATA AND DRAWING SUBMITTALS

- A. Vendor shall submit the information required on the Data Sheets and as requested on the Vendor Data Requirements sheet and shall receive written approval on the submittals from the Engineer prior to shipment of equipment.



DATA SHEET

FOR

VERTICAL TURBINE PUMPS

(All Blanks To Be Filled In By Bidder)

Item: Raw Water Influent Sump Pump

Equipment Number: P-104, P-105 Quantity: Two (2)

Type: Vertical Turbine

Service: Raw Ground Water Location: Outside

Manufacturer: _____ Model: _____

OPERATING CONDITIONS

Liquid: Water and Suspended Carbon Fines and Sand Temperature: Ambient

Specific Gravity: 1.0 Viscosity @ PT: 1.26 @ 68°F

Capacity: 700 gpm

Total Discharger Head: 161'

Abrasive: Yes Pulpy: No pH: 6-10 Duty: Continuous 24 hr/day

Sump Size 8' x'24' x 12' deep

Power Available: 480 V 3 phase 60 Hz

PUMP SPECIFICATION

Impellers: Type Enclosed Wearing Rings Material: _____

Diameter: _____ Material: Bronze

Number of Stages: _____ Speed (r/min): _____ BHP: _____

Pump Efficiency: _____

Bowl: Type Flanged Material: _____

Seal Ring Material: _____ Diameter: _____

Height: _____ Wearing Rings Material: _____

Column: Type Flanged Material: _____

Diameter: _____ Height: _____

Suction Head: Type Flanged Material: _____

Opening Area: _____



Strainer: Type _____ Material: _____

Net Opening Area: _____

Shaft: Type _____ Material: _____

Size: _____ Coupling Type: _____

Bearing Sleeves Materials: _____

Bearing Sleeve Lubrication: Water

Discharge Head: Type Flanged Construction: _____

Discharge Column Size: _____ Stuffing Box Type: _____

Stuffing Box Lubrication: _____ Packing: _____

Discharge Pipe (Diameter): _____

Drive: Coupling Type _____ Material: _____

Motor: Type Induction HP: _____ Frame Size: _____

r/min: _____ Thrust Bearing Type: _____

Manufacturer: _____

Lubrication: (Other than water)

Control: Pump level control and high level alarm switch by others

(not by pump manufacturers)

Net Weight of Pump: _____

Remarks: _____



DATA SHEET
FOR
VERTICAL TURBINE PUMPS
 (All Blanks To Be Filled In By Bidder)

Item: Effluent Sump Pump
 Equipment Number: P-501, P-502, P-503 Quantity: Three (3)
 Type: Vertical Turbine
 Service: Filter Treated Water Location: Outside
 Manufacturer: _____ Model: _____

OPERATING CONDITIONS

Liquid: Water Filtered and Treated Temperature: Ambient
 Specific Gravity: 1.0 Viscosity @ PT: 1.26 @ 68°F
 Capacity: 1000 gpm each
 Total Discharger Head: 53'
 Abrasive: No Pulpy: No pH: 6-10 Duty: Continuous 24 hr/day
 Sump Size 12' x 24' x 12' deep
 Power Available: 480 V 3 phase 60 Hz

PUMP SPECIFICATION

Impellers: Type Enclosed Wearing Rings Material: _____
 Diameter: _____ Material: Bronze
 Number of Stages: _____ Speed (r/min): _____ BHP: _____
 Pump Efficiency: _____
 Bowl: Type Flanged Material: _____
 Seal Ring Material: _____ Diameter: _____
 Height: _____ Wearing Rings Material: _____
 Column: Type Flanged Material: _____
 Diameter: _____ Height: _____
 Suction Head: Type Flanged Material: _____
 Opening Area: _____



Strainer: Type _____ Material: _____

Net Opening Area: _____

Shaft: Type _____ Material: _____

Size: _____ Coupling Type: _____

Bearing Sleeves Materials: _____

Bearing Sleeve Lubrication: Water

Discharge Head: Type Flanged Construction: _____

Discharge Column Size: _____ Stuffing Box Type: _____

Stuffing Box Lubrication: _____ Packing: _____

Discharge Pipe (Diameter): _____

Drive: Coupling Type _____ Material: _____

Motor: Type Induction HP: _____ Frame Size: _____

r/min: _____ Thrust Bearing Type: _____

Manufacturer: _____

Lubrication: (Other than water)

Control: Pump level control and high level alarm switch by others

(not by pump manufacturers)

Net Weight of Pump: _____

Remarks: _____

MOTOR DATA SHEET

EQUIP. NO. P-104, P-105 DRIVEN EQUIPMENT RAW WATER FEED PUMPS
HORSEPOWER _____ PH/FREQUENCY 3 PH 60Hz
MTR SYNCHRONOUS r/min _____ VOLTAGE 480 VAC
FRAME _____ AREA CLASSIFICATION NON HAZARDOUS
SPECIAL FEATURES GROUNDING LUG IN CONDUIT BOX

1. ENCLOSURE

- Open Dripproof
- NEMA Weather Protected Type I
- NEMA Weather Protected Type II
- Totally Enclosed Fan Cooled
- Special-Specify _____

2. CONSTRUCTION

- Horizontal
- Vertical Solid Shaft

3. FRAME SIZE

- Factory Standard for Rating
- Quoted Frame Size _____

4. SERVICE FACTOR

- 1.0 1.15
- Other, Specify _____
- Max Amb.Temp _____

5. ALTITUDE AND AMBIENT

- Up to 3300' (std)
- Other, Specify 5280'
- Max Amb.Temp 40 °C (std 40°C)

6. TEMPERATURE RISE

- Std per NEMA for Insul.Class, Serv.Factor,Ambient & Alt.
- Special-Class F insul. with Class B Rise at 1.15 S.F.
- Other _____ °C Rise at _____

7. RUNNING AND STARTING DUTY

- Continuous (standard)
- Start Cycle & Duty ___/day ___/hr.

8. BEARINGS

- Factory Standard for Rating
- Anti-Friction Ball
- Special-Specify _____

LUBRICATION

- Factory Standard for Rating
- Grease (Anti-Friction Ball Brgs)
- Special-Specify _____

9. STARTING METHOD

- Full Voltage, across the line
- Reduced Volt. _____ Type ___ % Volt
- Special-Specify _____

10. INSULATION CLASS

- A B
- F H

11. ASSEMBLY POSITION

- Right Side F-1 (std)
- Left Side F-2
- Special-Specify _____

12. CONDUIT BOX CONSTRUCTION

- Construction S (Standard)
- Construction A (Extra Leads and/or Stress Cones)

13. COUPLINGS AND SHEAVES

- Customer to Mount
- Special-Specify PUMP MOUNTED

14. TEST AND INSPECTION REQUIREMENTS

- Fac.Std.Unwitnessed Test for Rating
- Cust.Fac.Visual Insp. of Unit
- Special-Specify _____

15. SPACE HEATERS (Single Phase)

- None 120 V (std) 240 V
- 460 V 575 V Separate O/B
- Special-Specify _____

16. MOUNTING BASES

- None Slide Base Sole Plates
- Special-Specify _____

17. EFFICIENCY

- Standard Premium
- _____ Percentage Points Improvement Above Standard
- Loss Evaluation Factor S/kW _____
- If Guar. Method of Verif. _____
- Other _____

MOTOR DATA SHEET

EQUIP. NO. P-501, P-502, P-503 DRIVEN EQUIPMENT EFFLUENT SUMP PUMPS
HORSEPOWER _____ PH/FREQUENCY 3 PH 60Hz
MTR SYNCHRONOUS r/min _____ VOLTAGE 480 VAC
FRAME _____ AREA CLASSIFICATION NON HAZARDOUS
SPECIAL FEATURES GROUNDING LUG IN CONDUIT BOX

1. ENCLOSURE

- Open Dripproof
- NEMA Weather Protected Type I
- NEMA Weather Protected Type II
- Totally Enclosed Fan Cooled
- Special-Specify _____

2. CONSTRUCTION

- Horizontal
- Vertical Solid Shaft

3. FRAME SIZE

- Factory Standard for Rating
- Quoted Frame Size _____

4. SERVICE FACTOR

- 1.0 1.15
- Other, Specify _____
- Max Amb.Temp _____

5. ALTITUDE AND AMBIENT

- Up to 3300' (std)
- Other, Specify 5280'
- Max Amb.Temp 40 °C (std 40°C)

6. TEMPERATURE RISE

- Std per NEMA for Insul.Class, Serv.Factor,Ambient & Alt.
- Special-Class F insul. with Class B Rise at 1.15 S.F.
- Other _____ °C Rise at _____

7. RUNNING AND STARTING DUTY

- Continuous (standard)
- Start Cycle & Duty ___/day ___/hr.

8. BEARINGS

- Factory Standard for Rating
- Anti-Friction Ball
- Special-Specify _____

LUBRICATION

- Factory Standard for Rating
- Grease (Anti-Friction Ball Brgs)
- Special-Specify _____

9. STARTING METHOD

- Full Voltage, across the line
- Reduced Volt. _____ Type _____ % Volt
- Special-Specify _____

10. INSULATION CLASS

- A B
- F H

11. ASSEMBLY POSITION

- Right Side F-1 (std)
- Left Side F-2
- Special-Specify _____

12. CONDUIT BOX CONSTRUCTION

- Construction S (Standard)
- Construction A (Extra Leads and/or Stress Cones)

13. COUPLINGS AND SHEAVES

- Customer to Mount
- Special-Specify PUMP MOUNTED

14. TEST AND INSPECTION REQUIREMENTS

- Fac.Std.Unwitnessed Test for Rating
- Cust.Fac.Visual Insp. of Unit
- Special-Specify _____

15. SPACE HEATERS (Single Phase)

- None 120 V (std) 240 V
- 460 V 575 V Separate O/B
- Special-Specify _____

16. MOUNTING BASES

- None Slide Base Sole Plates
- Special-Specify _____

17. EFFICIENCY

- Standard Premium
- _____ Percentage Points Improvement Above Standard
- Loss Evaluation Factor S/kW _____
- If Guar. Method of Verif. _____
- Other _____



**VENDOR DATA REQUIREMENTS
MECHANICAL**

SPECIFICATION NUMBER: 36-1823

EQUIPMENT: Vertical Turbine Pumps P-104, P-105

The following data shall be furnished in the quantities indicated. Review copies shall be submitted 2 weeks after receipt of order; certified copies shall be submitted 4 weeks prior to shipment, unless noted otherwise. Transparencies are not required for drawing size 8 1/2" x 11".

Drawings and Data Required	Copies With Bid	Review Copies		Certified Copies		Remarks
		Prints	Transparencies	Prints	Transparencies	
1. Dimensioned Outline Drawings	4	6	1	6	1	
2. Cross Sectional Drawings						
3. Component and/or Detail Drawings						
4. Assembly and/or Erection Drawings		6	1	6	1	
5. Foundation Diagrams and Loading Requirements						
6. Engineering Calculations						
7. Schematic Piping Drawings						
8. Schematic Wiring Drawings						
9. Detailed Parts List				6		
10. Recommended Spare Parts with Prices				6		
11. Installation, Operation, Maintenance and Lubrication Manuals				6		
12. Completed Equipment Data Sheets	4					
13. Performance Curves and Data	4			6		
14. Catalog Information, Cuts, etc.	4					
15. Manufacturer's Inspection and Data Reports		6		6		
16. Mill Test Certificates						
17. Facsimiles or Rub-Offs of Code and Other Markings						
18. Welding Procedures						
19. Shipping and Operating Weights of Components	4			6		
20. Special Tools List and Cost	4			6		
21. Utilities Required: Compressed Air, Steam Water, Fuel						
22. Power Required: Volts, Amps, KW	4	6		6		
23. Motor Elementary Diagram		6		6		
24. Motor List	4	6		6		
25.						
26.						
27.						
28.						



<u>CONTENTS</u>	<u>PAGE</u>
1. SCOPE	3
2. RELATED WORK	3
3. REFERENCE STANDARDS	3
4. GENERAL	4
5. DETAIL REQUIREMENTS	4
6. VENDOR DATA AND DRAWING SUBMITTALS	6
7. PUMP DATA SHEETS	7
8. MOTOR DATA SHEETS	11



SPECIFICATION SECTION 36-1823

VERTICAL TURBINE PUMPS

1. SCOPE

A. This specification, Specification 36-0102, "GENERAL SPECIFICATIONS FOR EQUIPMENT", and other Contract Documents cover the furnishing of vertical turbine pumps as specified herein and on the drawings and attached Data Sheets.

2. RELATED WORK

A. The following items of related work are specified in other sections of the specifications:

- 1) Pump discharge piping beyond pump discharge flange (Specification 35-1501)
- 2) Electrical installation and field wiring (Specification 37-1601)
- 3) General Specifications for Equipment (Specification 36-0102)

3. REFERENCE STANDARDS

A. Manufactures standard product, embodying the design features and requirements specified herein and complying with the accepted standards of the industry, will be considered acceptable.

B. Organizations whose standards are referenced herein include the following:

- 1) AWWA - American Water Works Association
- 2) AFBMA - Anti-Friction Bearing Manufacturers Association
- 3) ANSI - American National Standards Institute
- 4) ASTM - American Society for Testing and Materials
- 5) NEMA - National Electrical Manufacturers Association



SPECIFICATION 36-1831

SUBMERSIBLE WELL PUMPS

CLIENT: SHELL OIL COMPANY

PROJECT: ROCKY MOUNTAIN ARSENAL REMEDIATION PROJECT

INTERIM RESPONSE ACTION FINAL DETAILED DESIGN

RAIL CLASSIFICATION YARD/MOTOR POOL AREA IRA

LOCATION: ROCKY MOUNTAIN ARSENAL, COMMERCE CITY, CO



	<u>CONTENTS</u>	<u>PAGE</u>
1.	SCOPE	3
2.	REFERENCE STANDARDS	3
3.	GENERAL REQUIREMENTS	3
4.	CONTROLS	4
5.	VENDOR DATA AND DRAWING SUBMITTALS	4



SPECIFICATION 36-1831

SUBMERSIBLE WELL PUMPS

1. SCOPE

A. This specification, Specification 36-0102, "GENERAL SPECIFICATIONS FOR EQUIPMENT," and other Contract Documents cover the furnishing of submersible pump units, complete with motor and power cable, as specified herein and on the attached Data Sheet.

2. REFERENCE STANDARDS

A. The equipment and/or its component parts shall be designed, manufactured and tested in accordance with the applicable requirements of the latest edition of the following codes, standards and references:

- 1) NEMA - National Electrical Manufacturers Association

3. GENERAL REQUIREMENTS

A. Bowls: Bowls shall be water lubricated and properly sized and constructed of materials which provide high efficiency, long life, and low cost. Pump shafts and impellers shall be 304 stainless steel.

B. Motor Adapters: Motor adapters shall be selected on the basis of nominal size bowl assembly selected and the nominal size motor being used.

C. Column Pipe: Column pipe shall be Schedule 80, PVC pipe with threaded PVC couplings. The pumps shall include NPT discharge for connection to fittings at the base of the column pipe. Installation shall ensure against unscrewing of pipe due to starting torque of the motor.

D. Check Valves: The pumps shall include fail safe, 304 stainless steel check valves built into the top pump chamber to prevent backflow. These valves shall be of positive, non-clogging, non-slamming design.

E. Motors: Motors shall be furnished which are manufactured by a nationally known company having a history of making quality motors for submersible pumps. The motor shall conform to the pump manufacturer's specifications, and sized to fit in the well and permit full flow of water



around the outside without restricting maximum pump capacity. Bearings shall be designed to carry downthrust and upthrust of the pump. A thermal protector shall be provided on the motor winding to prevent excessive temperature. The motor shall have a built-in lightning arrester for protection against voltage surges exceeding the motor insulation capability. Motors shall be as manufactured by Franklin Inc. (or Engineer-approved equal).

- F. Motor Shroud: Pumps shall include a PVC shroud to ensure adequate flow of cooling water past the pump motor. The shroud shall be made of SDR 32.5 PVC. All 6" pumps shall have 6" shrouds. All 4" pumps shall have 4" shrouds.
- G. Cable: Cable shall be sized to carry full load amperes of the motor being used, at the voltage specified. Sufficient cable length shall be provided to allow for possible twist or sag of cable during installation, plus 15 ft beyond the surface plate. The cable shall have a flexible metallic shielding around the conductors and an overall jacket with excellent abrasion resistant characteristics.
- H. Cable Guard: Stainless steel cable guards shall be provided to guide the electrical cable past the pump.
- I. Parts and Fasteners shall be provided as required to provide a complete pump system from the electrical conduit box to the discharge flange, except that the well casing and mounting flange for the discharge head shall be provided by others.
- J. Safety Cable supporting the pump shall be 316 stainless steel, with a minimum diameter of 1/4 inch.

4. CONTROLS

- A. Low-level and high-level cutoff switches shall be set above the pump intake. The Engineer will establish the required level settings.

5. VENDOR DATA AND DRAWING SUBMITTALS

- A. Vendor shall submit the information required on the data sheets and as requested on the vendor data requirements sheet and shall receive written approval on the submittals from the Engineer prior to shipment of equipment.



DATA SHEET

FOR

WELL PUMPS

(Bidder To Fill In All Blanks and Note Any
 Variance from the Specified Value)

Equipment Number: PU 301-307 and PU 401-402 Quantity: Nine (9)

Service: Dewatering wells

Pump Manufacturer: _____ Model No.: _____

Inside Diameter of Well Casing, Minimum: 7.62 in.

Liquid Pumped: Contaminated groundwater Temperature: 55°F

Specific Gravity: 1.00 Viscosity: 1.4 centipoise

Suspended Material: 100 ppm pH Range: 6 to 10

Capacity and Head:

Wells PU 301 through PU 305

Normal: 61 gpm at 129 ft tdh

Maximum: 95 gpm at 77 ft tdh

Minimum: 45 gpm at 144 ft tdh

Wells PU 306 through PU 307

Normal: 83 gpm at 160 ft tdh

Maximum: 95 gpm at 124 ft tdh

Minimum: 45 gpm at 232 ft tdh

Wells PU 401 through PU 402

Normal: 58 gpm at 120 ft tdh

Maximum: 75 gpm at 85 ft tdh

Minimum: 40 gpm at 140 ft tdh

Depth of Setting: approximately 95 to 120 ft below surface

Casing Size and Type varies: 8" Schedule 80 PVC and 8" continuous slot PVC

Service Duty: 24 hrs/day Potential Starting Cycles: 48 per day



Power Available: 240 V 3 Phase 60 Hz

Pump Construction:

Bowl _____ Impeller 304 stainless steel
 Diffusers 304 stainless steel Shaft 304 stainless steel
 Straps 304 stainless steel Check Valves 304 stainless steel
 Couplings Various stainless steel Cable Guards 304 stainless steel
 Inlet Screen 304 stainless steel

Discharge Column Pipe:

Pipe Size 3" Material PVC
 Schedule 80 Couplings Threaded PVC

Motor:

Manufacturer _____ Model _____
 hp varies - 3 hp and 5 hp rpm _____

Cable:

Cable Size 1/4 inch minimum Cable Type 316 stainless steel

Remarks: Pumps in Wells RYDW1 through RYDW5 shall be Grundfos Model 75S30-5
with 3 hp motor (or Engineer approved equal).
Pumps in Wells RYDW6 and RYDW7 shall be Grundfos Model 75S50 8
with 5 hp motor (or Engineer approved equal).
Pumps in Wells MPDW1 and MPDW2 shall be Grundfos Model 60S30 5
with 3 hp motor (or Engineer approved equal).



DATA SHEET

FOR

WELL PUMPS

(Bidder To Fill In All Blanks and Note Any
 Variance from the Specified Value)

Equipment Number: PU 511-514 Quantity: Four (4)

Service: Extraction wells

Pump Manufacturer: _____ Model No.: _____

Inside Diameter of Well Casing, Minimum: 7.50 in.

Liquid Pumped: Contaminated groundwater Temperature: 55°F

Specific Gravity: 1.00 Viscosity: 1.4 centipoise

Suspended Material: 100 ppm pH Range: 6 to 10

Capacity and Head:

Well PU 511

Normal: 140 gpm at 110 ft tdh

Maximum: 200 gpm at 50 ft tdh

Minimum: 75 gpm at 140 ft tdh

Wells PU 512 through PU 514

Normal: 225 gpm at 135 ft tdh

Maximum: 290 gpm at 89 ft tdh

Minimum: 150 gpm at 176 ft tdh

Depth of Setting: approximately 80 to 125 ft below surface

Casing Size and Type varies: 8" Sch 80 PVC, Continuous slot PVC, and
Stainless Steel

Service Duty: 24 hrs/day Potential Starting Cycles: 48 per day



Power Available: 240 V 3 Phase 60 Hz

Pump Construction:

Bowl _____ Impeller 304 stainless steel
 Diffusers 304 stainless steel Shaft 304 stainless steel
 Straps 304 stainless steel Check Valves 304 stainless steel
 Couplings Various stainless steel Cable Guards 304 stainless steel
 Inlet Screen 304 stainless steel

Discharge Column Pipe:

Pipe Size 3" Material PVC
 Schedule 80 Couplings Threaded PVC

Motor:

Manufacturer _____ Model _____
 hp 5 rpm _____

Cable:

Cable Size 1/4 inch minimum Cable Type 316 stainless steel

Remarks: Pump in Well ISEW39 shall be Grundfos Model 135S50-3 with 5 hp motor (or Engineer approved equal).

Pumps in Wells ISEW40 through ISEW42 shall be Grundfos Model 225S100-4 with 10 hp motor (or Engineer Approved equal).



**VENDOR DATA REQUIREMENTS
MECHANICAL**

SPECIFICATION NUMBER: 36-1831

EQUIPMENT: Submersible Well Pumps PU-201 thru 207, PU301 and PU-302

The following data shall be furnished in the quantities indicated. Review copies shall be submitted 2 weeks after receipt of order; certified copies shall be submitted 4 weeks prior to shipment, unless noted otherwise. Transparencies are not required for drawing size 8 1/2" x 11".

Drawings and Data Required	Copies With Bid	Review Copies		Certified Copies		Remarks
		Prints	Transparencies	Prints	Transparencies	
1. Dimensioned Outline Drawings	4	6	1	6	1	
2. Cross Sectional Drawings						
3. Component and/or Detail Drawings						
4. Assembly and/or Erection Drawings		6	1	6	1	
5. Foundation Diagrams and Loading Requirements		6		6		
6. Engineering Calculations						
7. Schematic Piping Drawings						
8. Schematic Wiring Drawings						
9. Detailed Parts List				6		
10. Recommended Spare Parts with Prices				6		
11. Installation, Operation, Maintenance and Lubrication Manuals				6		
12. Completed Equipment Data Sheets	4					
13. Performance Curves and Data	4			6		
14. Catalog Information, Cuts, etc.	4					
15. Manufacturer's Inspection and Data Reports		6		6		
16. Mill Test Certificates						
17. Facsimiles or Rub-Offs of Code and Other Markings						
18. Welding Procedures						
19. Shipping and Operating Weights of Components	4	6		6		
20. Special Tools List and Cost	4			6		
21. Utilities Required: Compressed Air, Steam Water, Fuel						
22. Power Required: Volts, Amps, KW	4	6		6		
23. Motor Elementary Diagram		6				
24. Motor List	4	6		6		
25.						
26.						
27.						
28.						



SPECIFICATION 36-2614

BAG FILTERS

CLIENT: SHELL OIL COMPANY

PROJECT: ROCKY MOUNTAIN ARSENAL REMEDIATION PROJECT

INTERIM RESPONSE ACTION FINAL DETAILED DESIGN

RAIL CLASSIFICATION YARD/MOTOR POOL AREA IRA

LOCATION: ROCKY MOUNTAIN ARSENAL, COMMERCE CITY, CO



	<u>CONTENTS</u>	<u>PAGE</u>
1.	SCOPE	3
2.	RELATED WORK	3
3.	REFERENCE STANDARDS	3
4.	DESIGN CRITERIA	3
5.	ASSEMBLY AND SHIPPING	4
6.	VENDOR DATA AND DRAWING SUBMITTALS	4



SPECIFICATION 36-2614

BAG FILTERS

1. SCOPE

A. This specification, Specification 36-0102, "GENERAL SPECIFICATIONS FOR EQUIPMENT", and other Contract Documents cover the furnishing of bag filter units complete with required bags, as specified herein and on the attached Data Sheets.

2. RELATED WORK

A. The following item of related work is specified in other specifications:

- 1) General Specifications for Piping (Specification 35-1501)

3. REFERENCE STANDARDS

A. Manufacturer's standard product, containing the design features and requirements specified herein and complying with the accepted standards of the industry, will be considered acceptable.

B. Organizations whose standards are referenced herein include the following:

- 1) ANSI - American National Standards Institute
- 2) ASME - American Society of Mechanical Engineers

4. DESIGN CRITERIA

A. The bag filter supplier shall be responsible for design, fabrication, shop assembly, and furnishing of all necessary components for a properly operating bag filter as described herein for installation by others.

- 1) Service: Filtering well water contaminated with organic compounds.
- 2) Filtration Requirements: Bag filter shall be capable of filtering solids only. Particle sizes, flow rate and filter capability shall be as noted on the attached Data Sheet.



- 3) Filter System Type: Filter shall be a bag filter with disposable bag unit. The filter shall be suitably designed to permit bag replacement by one individual.
- 4) Construction Material: Housing to be 304 or 316 stainless steel with the inlet, outlet, vent and drain fabricated from 304 or 316 stainless steel.

5. ASSEMBLY AND SHIPPING

- A. The filters shall be shop assembled, tested and inspected at the manufacturer's shop prior to shipment. Machined surfaces shall be protected from damage. Loose parts shall be shipped with the unit and tagged to facilitate field assembly.

6. VENDOR DATA AND DRAWING SUBMITTALS

- A. Vendor shall submit the information required on the Data Sheets and as requested on the Vendor Data Requirements sheet and shall receive written approval on the submittals from the Engineer prior to shipment of equipment.



DATA SHEET

FOR

BAG FILTERS

(Bidder To Fill In All Blanks)

Equipment No.: S-107A, S-107B Bidder: _____
 Equipment Name: Pre-Filters Service: RAW Groundwater Filtration
 Quantity: 2 (Two) Type: Pressure Bag Filter
 Manufacturer: Rosedale Products (or Equal) Model No.: _____

FLUID DESCRIPTION

Type: Organic Contaminated Groundwater
 Temperature (°F): 55-70 Specific Gravity: 1.0 pH: 6-8
 Solids: Mostly carbon fines and sand

DESIGN CRITERIA

Capacity (GPM): 1000 ea. Design Pressure (PSI): 100
 Pressure Drop (PSI): Clean Maximum Allowable 10
 Total Filter Area (Sq. Ft.): _____

VESSEL SPECIFICATION

Dimension (inches): Length _____ Diameter _____
 ASME Code Stamp Req'd: Yes _____ No X
 Piping Connections (Type/Size (inches)):
 Inlet: Flanged/ Outlet: Flanged/
 Drain: NPT/ Instrument: NPT/
 Cover Type: _____
 Baskets: Quantity _____ Area Each _____
 Wetted Parts Material of Construction: 304 or 316 Stainless Steel
 Overall Dimension (inches): Length _____ Width _____ Height _____

FILTER BAG SPECIFICATION

Quantity: _____ Bags/Filter Micron Rating: 20
 No. Req'd/Vessel: _____
 Dimension (inches): Length _____ Diameter _____
 Material of Construction: Polypropylene

Remarks: _____



DATA SHEET

FOR

BAG FILTERS

(Bidder To Fill In All Blanks)

Equipment No.: S-108A, S-108B Bidder: _____
Equipment Name: First-Stage Post-Filters Service: Adsorber Effluent Filtration
Quantity: 2 (Two) Type: Pressure Bag Filter
Manufacturer: Rosedale Products (or Equal) Model No.: _____

FLUID DESCRIPTION

Type: Carbon Adsorber Treated Water
Temperature (°F): 55-70 Specific Gravity: 1.0 pH: 6-8
Solids: Mostly carbon fines

DESIGN CRITERIA

Capacity (GPM): 1000 ea. Design Pressure (PSI): 100
Pressure Drop (PSI): Clean Maximum Allowable 10
Total Filter Area (Sq. Ft.): _____

VESSEL SPECIFICATION

Dimension (inches): Length _____ Diameter _____
ASME Code Stamp Req'd: Yes _____ No X
Piping Connections (Type/Size (inches)):
Inlet: Flanged/ Outlet: Flanged/
Drain: NPT/ Instrument: NPT/
Cover Type: _____
Baskets: Quantity _____ Area Each _____
Wetted Parts Material of Construction: 304 or 316 Stainless Steel
Overall Dimension (inches): Length _____ Width _____ Height _____

FILTER BAG SPECIFICATION

Quantity: Bags/Filter Micron Rating: 20
No. Req'd/Vessel: _____
Dimension (inches): Length _____ Diameter _____
Material of Construction: Polypropylene

Remarks: _____



DATA SHEET

FOR

BAG FILTERS

(Bidder To Fill In All Blanks)

Equipment No.: S-109 Bidder:
Equipment Name: Second-Stage Post-Filters Service: Adsorber Effluent Filtration
Quantity: 1 (One) Type: Pressure Bag Filter
Manufacturer: Filter Specialist Inc. Model No.: FS-2000-8

FLUID DESCRIPTION

Type: Water
Temperature (°F): 55-70 Specific Gravity: 1.0 pH: 6-8
Solids: Mostly carbon fines

DESIGN CRITERIA

Capacity (GPM): 1600 Design Pressure (PSI): 100
Pressure Drop (PSI): Clean Maximum Allowable 2.0
Total Filter Area (Sq. Ft.):

VESSEL SPECIFICATION

Dimension (inches): Length Diameter
ASME Code Stamp Req'd: Yes No X
Piping Connections (Type/Size (inches)):
Inlet: Flanged/ Outlet: Flanged/
Drain: NPT/ Instrument: NPT/
Cover Type:
Baskets: Quantity Area Each
Wetted Parts Material of Construction: 304 or 316 Stainless Steel
Overall Dimension (inches): Length Width Height

FILTER BAG SPECIFICATION

Quantity: Bags/Filter Micron Rating: 10
No. Req'd/Vessel:
Dimension (inches): Length Diameter
Material of Construction: Polypropylene

Remarks:

VENDOR DATA REQUIREMENTS MECHANICAL

SPECIFICATION NUMBER: 36-2614

EQUIPMENT: Bag Filters S-107 A&B, S-108 A&B, S-109

The following data shall be furnished in the quantities indicated. Review copies shall be submitted 2 weeks after receipt of order; certified copies shall be submitted 4 weeks prior to shipment, unless noted otherwise. Transparencies are not required for drawing size 8 1/2" x 11".

<u>Drawings and Data Required</u>	Copies With Bid	Review Copies		Certified Copies		Remarks
		Prints	Transparencies	Prints	Transparencies	
1. Dimensioned Outline Drawings	4	6	1	6	1	
2. Cross Sectional Drawings						
3. Component and/or Detail Drawings						
4. Assembly and/or Erection Drawings		6	1	6	1	
5. Foundation Diagrams and Loading Requirements						
6. Engineering Calculations						
7. Schematic Piping Drawings						
8. Schematic Wiring Drawings						
9. Detailed Parts List				6		
10. Recommended Spare Parts with Prices				6		
11. Installation, Operation, Maintenance and Lubrication Manuals				6		
12. Completed Equipment Data Sheets	4					
13. Performance Curves and Data						
14. Catalog Information, Cuts, etc.	4					
15. Manufacturer's Inspection and Data Reports						
16. Mill Test Certificates						
17. Facsimiles or Rub-Offs of Code and Other Markings						
18. Welding Procedures						
19. Shipping and Operating Weights of Components	4			6		
20. Special Tools List and Cost						
21. Utilities Required: Compressed Air, Steam Water, Fuel						
22. Power Required: Volts, Amps, KW						
23. Motor Elementary Diagram						
24. Motor List						
25.						
26.						
27.						
28.						



SPECIFICATION 37-1601

ELECTRICAL WORK

CLIENT: SHELL OIL COMPANY

PROJECT: ROCKY MOUNTAIN ARSENAL REMEDIATION PROJECT

INTERIM RESPONSE ACTION FINAL DETAILED DESIGN

RAIL CLASSIFICATION YARD/MOTOR POOL AREA IRA

LOCATION: ROCKY MOUNTAIN ARSENAL, COMMERCE CITY, CO



<u>CONTENTS</u>	<u>PAGE</u>
1. SCOPE	3
2. DEFINITIONS	3
3. REFERENCE STANDARDS	3
4. RELATED WORK	4
5. GENERAL REQUIREMENTS	4
6. SPECIAL REQUIREMENTS	5
7. CONNECTION TO EXISTING SYSTEM	5
8. INTERRUPTION OF EXISTING ELECTRICAL AND OTHER NECESSARY SERVICES	5
9. DEMOLITION AND REMOVAL	5
10. REQUIRED ITEMS OF WORK	6
11. WIRE AND CABLE METHODS	6
12. CONDUIT AND CONDUIT FITTINGS	11
13. GROUNDING SYSTEM	16
14. PANELBOARDS	16
15. WIRING DEVICES	17
16. LIGHTING FIXTURES AND LAMPS	17
17. INDIVIDUALLY MOUNTED MOTOR STARTERS	18
18. MOTOR CONTROLLER HEATER ELEMENTS	19
19. INDIVIDUALLY MOUNTED CONTROL STATIONS	19
20. SAFETY SWITCHES	19
21. EMPTY CONDUITS, OUTLETS AND CABINETS FOR TELEPHONE SERVICE	19
22. FUSES	19
23. ELECTRIC HEAT TRACING	19
24. MOTORS	21
25. IDENTIFICATION	21
26. SUPPORTS FOR EQUIPMENT	21
27. PHASE ROTATION	22
28. DIRECT BURIED CONDUIT	22
29. CUTTING AND PATCHING	23
30. ELECTRICAL TESTING	23
31. START-UP ASSISTANCE	24
32. DRAWINGS	24
33. AS-BUILTS	24
34. VENDOR DATA AND DRAWING SUBMITTALS	25
APPENDIX A STANDARD ELECTRICAL DETAILS	26
APPENDIX B ELECTRICAL PANEL SCHEDULES	27



SPECIFICATION 37-1601

ELECTRICAL WORK

1. SCOPE

- A. This specification, the specification listed below, and other Contract Documents cover the furnishing and installing of electrical work as required by the drawings and as specified herein.

2. DEFINITIONS

- A. The term "Owner" as used herein shall mean the firm named in the project title for whom the facility is being constructed.
- B. The term "Engineer" as used herein shall mean the "Owner's" appointed representative authorized to act on technical matters as specified herein.
- C. The term "Contractor" as used herein shall mean the "Electrical Contractor" responsible for the installation, interconnection and testing of a complete and operable electrical system as specified herein.

3. REFERENCE STANDARDS

- A. All equipment, materials, construction and installation shall be in accordance with the following applicable codes and standards:
- 1) ANSI - American National Standards Institute
 - 2) IEEE - The Institute of Electrical and Electronics Engineers, Inc.
 - 3) ICEA - Insulated Cable Engineers Association
 - 4) NEMA - National Electrical Manufacturers Association
 - 5) NFPA/
NEC - National Fire Protection Association/
National Electrical Code
 - 6) NESC - National Electrical Safety Code
 - 7) OSHA - Occupational Safety and Health Administration



- 8) UL - Underwriters' Laboratories, Inc.
- 9) Applicable State of Colorado Electrical, Building, Energy, Fire, and Safety Codes
- 10) Local codes

4. RELATED WORK

- A. Several items of work are specified in other specifications and are not included in the work covered by this specification.
 - 1) 13.8 kV Pole Line (Specification 37-1651)
 - 2) Acceptance Testing Specifications for Electrical Power Systems (Specification 37-1655)

5. GENERAL REQUIREMENTS

- A. In addition to the requirements of Specification 36-0102, all equipment shall be in accordance with the requirements of the applicable portion of the codes, regulations and standards listed in this specification.
- B. If any code or standard is changed during the construction period, these specifications may be changed by mutual written agreement between the Engineer and the Contractor.
- C. In the event of any discrepancy between one drawing and another or between the drawings and this specification, the Contractor shall bring such discrepancies to the attention of the Engineer for a written ruling.
- D. It shall be the Contractor's responsibility to assure that all requirements of inspection authorities are complied with.
- E. Names of approved manufacturers are listed in this specification. Products of other manufacturers may be used with the written approval of the Engineer if the item allows an "or equal".



6. SPECIAL REQUIREMENTS

A. Equipment to be supplied with this specification shall be designed and constructed to operate successfully at the rated values under the following conditions:

- 1) Elevation: 5,215 feet above sea level
- 2) Outdoor Temperature: -20° to 110°F
- 3) Seismic Zone: 1 (UBC)

7. CONNECTION TO EXISTING SYSTEM

- A. Contractor to connect existing power supply in existing wireway to new 200A disconnect switch in the Irondale plant.
- B. Contractor to install new feeder cable from relocated 1000 kVa transformer to new 1200A disconnect switch in plant.
- C. Contractor to tap into existing 13.8 kV power line at metering building and feed building.
- D. Contractor to tap into existing 13.8 kV power line at 3 locations to feed well heads.
- E. Contractor to connect new telephone cable to existing line across road at metering building.

8. INTERRUPTION OF EXISTING ELECTRICAL AND OTHER NECESSARY SERVICES

- A. Any tie-ins or alterations to, or replacement of, existing circuits or equipment required to accomplish the work, shall be scheduled in such manner as to reduce out-of-service time to a minimum. Upon request, and in cooperation with the Owner and the Field Engineer, Contractor shall prepare a written schedule of dates, time and number of hours needed for all shutdowns.

9. DEMOLITION AND REMOVAL

- A. Before proceeding with this work, Contractor shall consult with the Engineer and the Owner who will designate which, if any, removed items are to be salvaged. All other removed equipment and materials shall be discarded and removed from the site.
- B. Items designated as salvageable or to be reinstalled shall be removed, dismantled and disassembled as required, tagged for identification, transported if



required, and turned over to others for reinstallation and/or placed in storage as directed by the Engineer.

- C. Contractor shall not be responsible for any damage or breakage occurring during removal, dismantling and disassembly of existing items, provided reasonable care is used as determined by the Engineer. During all subsequent operations and until unit items are turned over to others or placed in storage, the Contractor shall be responsible for repairing or replacing any existing salvageable items which are damaged or broken.

10. REQUIRED ITEMS OF WORK

- A. The work involved shall be in accordance with the following:
- 1) The drawings for construction.
 - 2) The contents of this specification.
 - 3) The installation and testing instructions of the manufacturers of equipment or materials supplied to or by the Contractor for installation, unless the specification or the drawings call for more stringent requirements.
- B. All electrical systems, both above grade and below grade, shall be completed as outlined on the drawings and in this specification, and be ready for use. A set of Standard Electrical Details is provided in Appendix A. These are to be used in conjunction with the drawings.
- C. The wiring interconnection of the instrumentation is shown on the electrical drawings and is covered under this specification.
- D. Labor and materials which are necessary for the completion and satisfactory operation of the electrical systems listed in this specification shall be furnished, whether or not the same are specifically shown on the drawings or called for in these specifications.

11. WIRE AND CABLE METHODS

- A. General: As required by the drawings, all power, control, instrumentation and communication wiring shall be furnished and installed unless otherwise specified, and shall meet NEMA-WC, ICEA, UL, OSHA, and NEC standards for wire, cable and workmanship.
- B. 600 V Cables: All single conductor wiring for power, lighting and control circuits installed in conduit for



operating at 600 V or below shall be UL approved stranded soft annealed copper, type XHHW or THWN, 75°C temperature rating for wet location. Stranding shall be per ASTM Class B. Minimum size wire shall be No. 12 AWG for power and lighting circuits and No. 14 AWG for control circuits unless otherwise shown on the drawings.

- C. 15 KV Cables: Medium voltage power cable 1/C #2, 15 KV shielded one copper conductor/90C rating 133% insulation level. (Okoguard - Okoseal type MV-90, Okonite Cat #115-23-311).

Cable breakout for 15 KV cable (pole to conduit transition)
Raychem Cat #CB-6-2-A

Cable termination kit for 15 KV for 15 KV 1/C cable terminations
Raychem Cat #HVT-151-G

Uninsulated copper compression terminal one hole, long barrel for 1/C #2 shielded 15 KV cable
(Burndy type YA HYLUG)

Contractor shall use equipment as listed in above catalog numbers or engineers approved equal.

REF Specification 37-1651 for cable installation details.

D. Control and Instrumentation Cable:

- 1) Twisted pair signal cables shall be constructed of two No. 16 AWG copper signal wires with high-density polyethylene or PVC insulation over each conductor, the pair twisted and triplexed with a copper drain wire and aluminum mylar tape applied over the triplexed group. Cable shall have an outer sheath of high-density polyethylene or PVC, rated 300 V. Cable shall be suitable for class 3 circuits.
- 2) Multi-conductor cables may be used for electronic instrument wiring where economically feasible. Cable shall consist of suitably identified No. 20 AWG copper signal wires with high-density polyethylene or PVC insulation over each conductor. Conductors shall be twisted in pairs and each pair shall be triplexed with a copper drain wire and aluminum mylar tape applied over the triplexed group. Cable shall include an overall layer of aluminum mylar tape, copper drain wire, No. 22 AWG insulated copper communications wire and an outer sheath of polyethylene or PVC. Cables run



underground, direct burial, shall be as above, but with suitable steel armor under the overall polyethylene or PVC sheath, rated 300 V. Cable shall be suitable for class 3 circuits.

E. Bare Copper:

- 1) Conductors shall be stranded, soft-drawing temper for grounding.
- 2) Conductors shall conform to the requirements of ASTM B-8, Stranded Concentric Lay, All Tempers.

F. Installation and Hardware:

1) General:

- a) Conduit systems and wireways shall be completed and cleaned free of debris before pulling in wires or cables. In general, wires and cables shall not be pulled in until splicing and testing can proceed immediately thereafter. Conduit systems and enclosures shall not be left open nor wires exposed to weather or mechanical hazards longer than necessary.
- b) Cables shall not be installed in conduit if the ambient temperature of the work area is below the manufacturer's recommended minimum handling temperature for the cable.
- c) Power conductors shall be continuous from termination to termination. Conductor splicing shall be done only when unavoidable and as approved by the Engineer. Splices and/or taps shall be made only in approved junction or terminal boxes.
- d) Cable pulling lubricants shall be used when pulling cables. The type of lubricants shall be suitable for the insulation involved. Cables shall be pulled directly from reels into the conduit raceway. Conductors shall not be laid out on the ground or triplexed prior to pulling into the raceway system.
- e) Pulling stresses applied to conductors shall not exceed the manufacturer's limitations.
- f) As a general rule, clearance shall be provided between random noise generating equipment and a parallel run of signal carrying conductors. Parallel runs, next to noise generating



equipment shall be avoided. However, if parallel runs cannot be avoided, the following minimum spacing shall be maintained between power cables and signal cables:

<u>Power Wiring Capacity</u>		<u>Minimum Separation</u>
120 V	up to 10 A	12 inches
240 V	up to 50 A	18 inches
480 V	up to 200 A	24 inches

Crossovers that bring power and signal cables into close proximity shall be made at right angles.

2) Low-Voltage Requirements:

- a) Low-voltage conductors No. 8 AWG and larger shall be terminated or spliced with compression-type connectors except where clamp or pressure type terminals are part of the connected equipment. Conductors smaller than No. 8 AWG used in lighting, HVAC or heat tracing may be spliced using twist-on connectors at junction points.
- b) Compression-type connectors for wiring 600 V or less shall be insulated with at least one turn of "Scotch Fil" Electrical Insulating Putty and then covered with two half laps of tape similar to 3M Company's No. 88 Plastic Tape.
- c) Wiring for control and instrument systems shall be terminated only on terminal blocks in designated terminal boxes or approved enclosures. Preinsulated compression-type connectors shall be used for field connection where possible. Terminal blocks shall be tubular screw type with pressure plates. No more than two conductors per terminal.
- d) Where possible, No. 6 AWG and smaller wire shall be color coded by the color of the insulation covering. Color coding of wire larger than No. 6 AWG may be by means of self-adhesive wrap-around type markers.
- e) Wires and cables shall be identified and/or color coded with reference to system source as follows:



- 480Y/277 V Systems
 - Phase A Brown
 - Phase B Orange
 - Phase C Yellow
 - Neutral Gray
 - Ground Green
 - 208Y/120 V and 120/240 V Systems
 - Phase A Black
 - Phase B Red
 - Phase C Blue
 - Neutral White
 - Ground Green
 - Dc Systems
 - Positive Black
 - Negative White
- f) An unidentified conductor may be substituted for a conductor of a different color; however, the conductor shall be identified with self-adhesive wrap-around type markers of the required color, at each spliced or terminated end and where the conductor is visible and accessible.
- g) Wire Marking: Wires shall be identified at the following locations:
- Power and lighting branch circuits and feeders at fixtures, outlets, motors, etc. Identify to indicate originating panel and circuit number.
 - Signal and control wires at all cabinets, terminal boxes, equipment racks, control panels, consoles, etc.
 - Wires smaller than No. 4 AWG shall be marked with heat-shrinkable sleeve type wire markers; wires sized No. 4 AWG and larger and multi-conductor cables shall be marked with one-piece, nylon locking marker ties.
- 3) Instrumentation Wiring: The number of splices in shielded signal wires and cables shall be kept to a minimum. Where splices are required, they shall be made in suitable terminal boxes with screw-type terminal blocks. Terminals shall be provided for each active and spare pair in multiconductor cables. The cable shield must be bonded to maintain electrical continuity at each cable splice. The



drain wire shall be grounded as shown on the drawings and shall be electrically continuous throughout the entire run. The overall cable shield should be grounded at one location only as shown on the drawings.

12. CONDUIT AND CONDUIT FITTINGS

A. General:

- 1) Conduit sizes, type and length shall be furnished and installed as required by the drawings and meet the latest edition of applicable standards and the requirements of the NEC.
- 2) Conduit found unacceptable shall not be installed and shall be removed from the premises upon notice.
- 3) All conduit ends shall be cut square, properly threaded and reamed. All connections shall be made up tight and weatherproof, engaging not less than five threads, and coated with approved thread compound, such as "Kopr-Shield" compound manufactured by Thomas and Betts.
- 4) Open ends of conduit shall be carefully plugged or capped during construction to prevent the entrance of foreign materials or moisture into the conduit. Before pulling wire or cable into the conduit system, a swab shall be drawn through the entire length of the conduit to remove any moisture, metal cuttings or other foreign material.
- 5) Where conduit enters through exterior concrete walls or below grade footings, the entrance shall be made watertight. Pipe sleeves shall be provided in the concrete with 1/2 inch minimum clearance around the conduit for an entrance seal similar to O-Z/Gendy Type FSK.
- 6) Where conduit enters through exterior metal walls, the opening shall be weatherproof sealed. Refer to Specification 33-1301, "Pre-Engineered Metal Building," for details.
- 7) Conduits larger than 1 inch shall not be installed in structural concrete slabs unless specifically approved in writing, or shown on the drawings.
- 8) Pull boxes shall be installed only at locations where they will be permanently accessible.



- 9) Pull points shall consist of approved cast metal boxes and fittings with gasketed cover joints.

B. Materials:

1) Conduit:

- a) Rigid Galvanized Steel Conduit (RGS) shall conform to ANSI C80.1 and be standard weight, mild rigid steel, hot-dipped galvanized with inside and outside finished with a protective zinc coating. Couplings, elbows and bends shall meet these same requirements.
- b) PVC Coated RGS shall conform to the above provisions in part a) and, in addition, provide not less than 40 mil. coating of PVC, ultraviolet resistant, shrink resistant.
- c) Flexible Conduit shall be liquid-tight with an integral grounding conductor, per UL 360, Anaconda Sealtite type UA or equal.

2) Boxes and Fittings:

- a) Boxes and fittings shall be compatible with the conduit system in which they are installed and shall conform to ANSI C80.4.
- b) Exposed Work: All conduit fittings, junction and device boxes shall be cast Type FS or FD with threaded hubs, steel covers and gaskets for use with RGS.
- c) For weatherproof locations, proper sealing gaskets in addition to self-closing hinged lids for receptacle covers shall be provided.
- d) Junction boxes shall be code gauge sheet steel hot-dipped galvanized after fabrication with bolted covers.
- e) Junction boxes and enclosures for outdoor areas and processing areas shall be NEMA 4X or as indicated on the drawings.
- f) Gasket material for conduit fittings and boxes shall be neoprene or other approved plastic.

3) Fire Stops:

- a) All electrical penetrations of fire rated walls, floors, and ceilings, as identified on



the contract documents, shall employ a fire stop system. The fire stop system is defined to be the combination of materials and/or devices, including the penetrating items, required to make up a complete fire stop.

- b) The fire resistance rating, in hours, of the completed fire stop shall be at least as long as the rating of the penetrated wall, floor or ceiling.
- c) Intumescent materials are acceptable, such as 3M brand CP 25 caulk and 303 putty. Multiple conduit penetrations shall employ a sealing system, such as 3M brand PSS 7902 and PSS 7094.
- d) Fire stop systems shall have been successfully tested by Underwriters' Laboratories in accordance with UL 1479 and ASTM E814, satisfying both the F and the T rating of the latter.

C. Installation of Above Grade Conduit Systems:

- 1) Conduit system shall be furnished and installed as required by the drawings. This system shall connect all outlet boxes, junction boxes, panelboards, cabinets, etc. Minimum size conduit shall be 1/2" unless otherwise noted on the drawings.
- 2) Field bends and offsets shall be uniform and symmetrical, without conduit flattening or finish scarring. Field bends shall be made with standard tools and equipment manufactured specifically for conduit bending. Minimum bend radii shall be as required by the NEC, but in no case less than six times conduit diameter.
- 3) Vent and drain fittings shall be installed where there is a possibility that water or other condensed vapor may be trapped at any point in the conduit system.
- 4) Expansion fittings or offsets shall be provided as required to compensate for thermal expansion and contraction and where crossing building expansion joints. Bonding jumpers shall be installed around all expansion fittings.
- 5) Pull fittings or boxes shall be installed wherever necessary on conduit systems to facilitate pulling wire and cables and shall be in accessible locations. In general, maximum distance for



straight runs shall be 200 feet. Not more than three 90-degree bends shall be permitted in one run.

- 6) Conduit shall be installed at least one foot from uninsulated hot pipes or hot surfaces unless type of wire used is approved by the Engineer. A hot pipe or hot surface is one where the surface temperature exceeds 125°F.
- 7) Conduit runs shall be exposed unless otherwise shown on the drawings. They shall be vertical, horizontal or parallel to structure lines. All horizontal conduits shall drain toward the vertical conduit to which they are connected.
- 8) Provisions for sealing and drainage shall be installed in the vertical drops of outside above grade conduit runs at the point at which the conduits enter buildings, switchgear, control panels, lighting panels, and other similar enclosures.
- 9) Outside above grade conduit runs that are extended below grade shall be provided with drain-seal fittings in a vertical drop directly above grade.
- 10) Conduit connections to motors and other equipment subject to vibration or movement shall be liquid-tight flexible steel conduit with suitable fittings. Each connection shall be of a minimum length as indicated in the table below:

<u>Liquid-Tight Flexible Conduit Size</u>	<u>Approximate Inside Bend Diameter</u>	<u>Minimum Length</u>
1/2"	5"	10"
3/4"	6"	12"
1"	8"	16"
1-1/2"	11"	18"
2"	14"	18"

- 11) In wet areas indoors and areas subject to washdown, the entire wiring system, boxes, conduit, and fittings shall be mounted so that 1/4 inch minimum space exists between system and supporting surface.
- 12) At all entrances to panelboards, pull boxes or outlet boxes (without threaded hubs or bases), conduit runs shall be secured in place by a galvanized locknut with an O-ring seal outside the box and a locknut and bushing on the inside.



Bushings shall be of the insulating type. NEMA 1 panelboards, pull boxes, etc., shall be secured in place by a galvanized locknut outside the box and a locknut and bushing inside. Bushings shall be of the insulating type.

- 13) Exposed conduit shall be rigidly maintained and fastened to structural steel by means of an approved clamp or device made for this purpose. On masonry structures, conduits shall be fastened with one-hole conduit clamps and clampbacks with flush anchors. The type of conduit support will depend on the type of construction, and/or details as indicated on drawings. Pull boxes shall be rigidly supported with structural steel supports.
- 14) All steel bolts, nuts, washers and screws shall be galvanized or cadmium plated.
- 15) Ring pipe or trapeze hangers may be used to support conduits, except for the first and last hangers of the conduit run or where a vertical or horizontal direction change occurs. In these cases, conduit supports must be rigidly braced so that wire may be pulled without damage to the conduit system. Stud welds, similar to those manufactured by Nelson Stud Welding, may be used for fastening clamps to steel. Flat straps shall not be used to support conduit or boxes. No drilling of building structural members, for supporting conduits, will be allowed without written permission of the Engineer, and/or Client/Owner. Conduit runs shall be supported as follows:

<u>Conduit Size, Inches</u>	<u>Maximum Spacing, Feet</u>
1/2 and 3/4	10
1 thru 2	12
2-1/2 and over	16

- 16) On vertical conduit runs, which are unsupported from the roof truss to the top of the enclosure, applicable fittings shall be used to fasten the conduit to the top of the enclosure for rigidity.
- 17) Unistrut or approved equal shall be used for banks of conduit. Provision for 30 percent future conduits shall be made.
- 18) Individual hangers and rods shall be prime zinc or cadmium coated.



- 19) Conduit bodies Type "LB," "LR," "LT," etc., shall not be used as splice boxes.

13. GROUNDING SYSTEM

- A. All below grade connections shall be exothermic. Above grade connections to motors and equipment shall be bolted pressure connector type and connections to building steel and structures shall be exothermic as indicated on the drawings. All connectors, bolts or clamps used shall be silicon bronze or other noncorroding type.
- B. Equipment remote from the existing main ground grid may be grounded by separate grounding electrodes and conductors. The resistance to ground of the completed system shall be less than five ohms.
- C. Copperweld ground rods shall be 3/4 inch x 10 feet. Top of ground rods shall be a minimum of two feet below grade. Additional sections of rods shall be driven as required to obtain the above system resistance.
- D. All non-current carrying metal parts of electrical equipment and installations shall be connected to the ground grid as required by the drawings. These will include, but not necessarily be limited to, raceways, electrical equipment enclosures and/or ground bus, transformers, and motor frames.
- E. Grounding jumpers shall be required around all flexible conduit connections for 1-1/2-inch seal-tight flexible conduit and larger. All flexible conduits without integral ground wire shall have a grounding jumper.

14. PANELBOARDS

- A. General: All panelboards shall be of the molded-case circuit breaker type manufactured in accordance with NEMA Standard PB-1, UL 67, UL 50, FS W-P 115b, and the NEC. Specific panelboard ratings and details shall be as indicated on the drawings or panel schedules.
- 1) Panelboard boxes shall be of code gauge galvanized sheet steel with gutter space that meets or exceeds UL requirements. Panel trim shall be of code gauge steel with a light gray finish.
- 2) Panelboards shall have hinged doors with keyed-alike flush cylinder locks and a directory card and holder on the inside of the door. The Contractor shall fill out the directory card completely in typed print listing all connected loads.



- 3) Panelboard main bus, main lug or breaker and short circuit rating shall be as indicated on the schedule. The minimum short circuit rating required will apply to all interrupting devices in the panel, except where branch devices have been UL tested in combination with a specific main device having a higher interrupting rating resulting in an "integrated short circuit rating." All "integrated short circuit rating" combinations shall be UL listed.

15. WIRING DEVICES

- A. As required by the drawings, all wiring devices shall be specification grade and furnished and installed by the Contractor unless otherwise specified.

16. LIGHTING FIXTURES AND LAMPS

A. General:

- 1) Contractor shall furnish, install, and connect all luminaires and lighting equipment and accessories shown on the plans. He shall furnish all labor and materials to install the specified equipment to make a completed system ready for service.
- 2) All luminaires and lighting equipment shall be delivered to the project site complete with suspension accessories, canopies, casings, sockets, holders, reflectors, diffusing materials, ballasts, etc., all wired and assembled. Contractor shall furnish all material and suspension accessories required for installation of the lighting system. All lighting fixtures shall be UL labeled.
- 3) Should the Contractor wish to furnish fixtures of manufacture other than shown in the fixture schedule, he shall furnish a complete description of fixtures, with photometric data, for approval in accordance with the terms of these specifications. Additional information, such as method of support, finishes and/or actual samples of fixtures shall be submitted for approval upon request. No fixture shall be submitted which does not resemble the fixtures specified in all respects.
- 4) Contractor shall be responsible for replacement of any damaged or defective fixtures, including glassware and plastics of diffusers, up to time of final inspection and acceptance by Client/Owner. Any deterioration of finishes visible on close inspection, at or before the end of the one-year



Contractor's guarantee period, shall be considered a defect under the terms of the guarantee.

- 5) Fixtures shall be installed and adjusted to give optimum illumination. When necessary, fixtures shall be moved to avoid obstructions after obtaining approval from the Engineer.
- B. Luminaire Wiring: Luminaire wiring, supports, and connections shall be in accordance with Article 410 of the latest edition of the NEC. No splice or tap shall be located within an arm, stem or chain. Wire shall be continuous from splice in outlet box of building wiring system to lamp socket or ballast terminal.
- C. Lamps: Contractor shall furnish and install lamps for lighting fixtures as specified on the drawings. Contractor shall be responsible for replacement of any damaged or defective lamp up to time of final inspection and acceptance by Client/Owner. Upon completion of work, there shall be a complete set of lamps of proper sizes and types, in good condition, in all fixtures.
- D. Ballasts: All ballasts shall meet the requirements of ANSI C82.
- 1) Fluorescent ballasts shall be high power factor, CBM (Certified Ballast Manufacturers) certified by ETL (Electrical Testing Laboratories, Inc.) with Class P internal ballast protection. Ballasts for 430 mA rapid start lamps shall be "A" sound rating. Ballasts for 800 mA rapid start lamps shall be "C" sound rating. Cold start rating -10°F
 - 2) Ballasts for high-intensity discharge lamps shall be high power factor (suitable for -20°F starting). Cold start and restart amperage shall not exceed operating amperage. Ballasts shall start lamps and operate satisfactorily at normal line voltage ± 10 percent.
- E. Cleaning: All fixtures shall be cleaned of dirt and foreign matter before the installation is turned over to the Client/Owner.

17. INDIVIDUALLY MOUNTED MOTOR STARTERS

- A. Local motor starters shall be furnished by the Contractor unless specifically indicated otherwise on the drawings.
- B. Manual starters shall be full-voltage, non-reversing, single speed, with melting or bimetallic alloy type ambient compensated thermal overload delays for 60-Hz



induction motors. NEMA size shall be as shown on the drawings. Indoor enclosures shall be NEMA 12 and outdoor enclosures shall be NEMA 4 unless indicated otherwise on the drawings.

18. MOTOR CONTROLLER HEATER ELEMENTS

- A. Contractor shall supply overload relay heater elements in accordance with actual motor nameplate full-load current.

19. INDIVIDUALLY MOUNTED CONTROL STATIONS

- A. Locally mounted control stations shall be heavy-duty, oiltight, in NEMA 4X enclosures for outdoor and processing area use. Devices and legend plates shall be as indicated on the drawings.

20. SAFETY SWITCHES

- A. Heavy duty safety switches shall be provided as shown on the drawings. Switches shall be UL listed. Indoor enclosures shall be NEMA 12 and outdoor enclosures shall be NEMA 4.

21. EMPTY CONDUITS, OUTLETS AND CABINETS FOR TELEPHONE SERVICE

- A. Provide conduit raceway system as shown on the drawings.

22. FUSES

- A. All fuses, except those specifically excluded, shall be furnished by the Contractor. Fuses shall be of the proper types and ratings.
- B. Where NEMA Class H fuse holders are used, furnish the following:
- 1) One-time standard fuses when short-circuit capacity is less than 10,000 A.
 - 2) UL Class RK-5 fuses when short-circuit capacity is greater than 10,000 A.
- C. Where fuse holders require UL Class J or L fuses, only those classes of fuses shall be furnished. No substitutions shall be allowed.

23. ELECTRIC HEAT TRACING

- A. Heat tracing system, complete with all necessary heating cable, thermostat bulbs, thermostats, and hardware needed for heat tracing operations to provide freeze protection



for pipe and associated valves and instruments, shall be designed, furnished and installed by the Contractor per manufacturer's recommendations as required by the drawings. The Contractor shall verify the adequacy of circuited heat tracing against actual installed piping. Heat trace calculations, installation details, and intended insulation materials shall be submitted to the Engineer for approval prior to purchasing.

- B. Electric heat tracing system components shall be approved by a recognized testing laboratory, such as Underwriters' Laboratories (UL) or Factory Mutual Corporation.
- C. Heat tracing system shall consist of self-limiting heating cable. Cable operating voltages shall be 120 V.
- D. Heat trace shall be Raychem-Chemelex Auto-Trace or equal. Heat trace to be submerged in water shall have a fluoropolymer outer jacket covering shield.
- E. The following design parameters shall be used:
 - 1) Maximum Temperature: 110°F
 - 2) Minimum Temperature: -20°F
 - 3) Maintenance Temperature: 40°F
 - 4) Safety Factor: 10%
- F. Thermostat sensing bulbs shall be ambient sensing and shall be located where it will be exposed to the coldest temperature and highest wind. The thermostat capillary shall be protected inside the insulation by fastening it to prevent tension on the capillary.
- G. Electrical tracers will normally be installed in the lower half of horizontal pipe runs. If there is more than one cable, locate them in the lower half approximately 30 degrees on either side of the vertical. The cable shall not cross other tracers, or touch itself, unless explicitly permitted by the manufacturer's specifications. Specific installation requirements shall be as shown on the installation drawings and/or manufacturer's data.
- H. Heat tracing tapes shall be fastened with double banding at all ends and splice points. Sufficient slack shall be provided for thermal expansion at these points.



- I. Heat cable shall be installed spiralling the cable on the pipe, where there is no insulation or where it is submerged in water.
- J. Each heater cable assembly shall be tagged with a permanent corrosion resistant metal tag securely attached to the junction box end of the "cold" section. The metal tag shall state the circuit numbers, heater designation.
- K. Heat trace circuits shall be tested prior to the installation of insulation and jacketing and again following insulation and jacketing installation to verify that no damage has been done to the heat trace system.

24. MOTORS

- A. In general, motors will be furnished with the driven equipment.
- B. The Contractor shall be responsible for electrical connections, tests and start-up of the motors.
- C. The Contractor shall observe vendor's instructions for setting motors and their controls. Motors shall not be energized until they have been checked for free rotation, correct alignment, proper lubrication and minimum insulation resistance values verified by tests. Motors shall be checked for rotation and given a trial run prior to coupling.
- D. The Contractor shall verify the installation of the correct quantity and size of overload heaters in each motor starter.

25. IDENTIFICATION

- A. Contractor shall furnish and install nameplates for identification of control stations, safety switches, individual motor starters and other electrical equipment not identified by factory nameplates. Nameplates shall be attached securely.
- B. The directory at each panelboard shall be neatly typed showing the destination of each circuit installed.

26. SUPPORTS FOR EQUIPMENT

- A. Contractor shall provide all necessary supports for equipment installed under this specification. Supports shall consist of steel frames, plates, brackets, racks and other shapes of adequate size and fastened with bolts, screws or by welding, to provide rigid support. Welds shall be continuous and, where exposed, ground



smooth. Thoroughly clean metal surfaces and apply one coat of primer. Any other material to be used for support shall have the Engineer's prior written approval.

27. PHASE ROTATION

- A. Required order of phase rotation for entire project shall be phase A, phase B, phase C, with voltage reaching maximum value in that order.
- B. For switchgear, motor control centers, panelboards and other distribution and motor control equipment, connect phase conductors to terminals in the order A-B-C from left to right, facing equipment. When not in conflict with the latter, due to standard arrangement, bus bars in this equipment shall be in the order A-B-C from front to back and top to bottom.

28. DIRECT BURIED CONDUIT

- A. Conduit in direct contact with earth shall be PVC coated steel conduit.
- B. The installation of PVC-coated conduit shall follow the installation instructions recommended by the manufacturer. Herein are extra steps to follow:
 - 1) Care must be taken to minimize damage to the PVC coating during cutting, threading, bending and assembly of components.
 - 2) Exposed metal due to damage of the PVC coating must be touched up with compound recommended by PVC-coated conduit manufacturer.
 - 3) To field cut, use a clamp-type vise, tighten to hold conduit securely. Cut conduit with a hacksaw or power saw.
 - 4) All conduits shall be reamed after cutting. Reamer shall be designed for use on PVC-coated conduit.
 - 5) Use only tools approved or recommended for use on PVC-coated conduit.
- C. Conduit bending radii shall be as large as possible and shall be not less than eight times nominal conduit diameter, and free from flats, kinks or damage.
- D. Conduit installation shall follow excavating as closely as possible. Conduit shall be installed in dry trenches maintained free of accumulated water.



- E. Conduit runs shall be kept closed at all times using pipe caps or plugs.
- F. After conduits are in place, backfill and compact fill to a depth above conduits as specified in drawings and applicable specifications. Install a continuous warning strip of red plastic in the excavation and continue backfill per drawings and specifications.
- G. Conduits in the same trench shall have a minimum horizontal and vertical separation of three inches.

29. CUTTING AND PATCHING

- A. Contractor shall avoid cutting into work of others using sleeves, inserts, chases and similar openings necessary for installation of his work. The other Contractor, in whose work it shall be necessary to use any of these methods, shall build same into his work, but the Electrical Work Contractor shall be responsible for correct size and location of same and shall furnish all sleeves and inserts.
- B. All cutting, welding or drilling of concrete or structural members shall be properly reinforced and patched to match as nearly as possible the surrounding work. Before cutting, welding or drilling any concrete or structural member, the Contractor shall secure written approval of the Engineer.
- C. If necessary to cut into work of a second contractor, it shall be done by the second contractor at the Electrical Work Contractor's expense or by the Electrical Contractor with consent of the second contractor. Any patching required shall be performed by the Contractor whose work was cut into at the Electrical Contractor's expense.

30. ELECTRICAL TESTING

- A. General: The Contractor shall, upon completion of the work, and before acceptance, perform complete functional operating tests of all systems governed by Specification 37-1655, "ACCEPTANCE TESTING SPECIFICATIONS FOR ELECTRICAL POWER SYSTEMS," in the presence of the Engineer. All systems and equipment shall be demonstrated to function in accordance with their obvious intent and the requirements of this specification. The Contractor shall furnish all required instruments and personnel for the tests and maintain the test equipment and apparatus in good condition at all times during the tests.



31. START-UP ASSISTANCE

- A. The Contractor shall provide start-up assistance to the Client/Owner and the Field Engineer as required. This start-up assistance shall include inspection, testing, pre-operational checkout, trouble shooting, and engineering support necessary to bring the facility into full operation.

32. DRAWINGS

- A. The electrical drawings are diagrammatic but shall be followed as closely as possible in the actual construction of the facilities and as the work of the other trades will permit.
- B. The Contractor shall verify drawing dimensions and layouts for clearance and interference prior to the commencement of any work.
- C. All changes from the drawings necessary to make the work conform to the facilities as constructed and to fit the work of other trades or to conform to the rules of state or local governing bodies having jurisdiction, shall be made by the Contractor at his own expense.
- D. In any case regarding a question of exact location of electrical equipment, the question shall be immediately submitted to the Field Engineer. Equipment shall not be located by the Contractor, without the Engineer's approval, save only at the Contractor's risk and expense. This expense shall include the cutting and patching of the work of others as may be necessary due to removing and relocating of said equipment, if so directed by the Engineer.
- E. Standard installation details are referenced throughout the drawings. Appendix A contains these details.

33. AS-BUILTS

- A. One (1) complete set of drawings issued for this contract shall be maintained exclusively for record purposes by the Contractor and all changes and modifications shall be shown and noted thereon in red color. Supplemental drawings or sketches may be added. Dimensions, clearances, sizes and significant references shall be added.
- B. Drawings shall be kept up to date and shall be available at all times for reference. All sketches, notes and data will be sufficiently clear to permit photo reproductions when needed.



34. VENDOR DATA AND DRAWING SUBMITTALS

- A. Vendor shall submit the information required on the Vendor Data Requirements Sheets and shall receive written approval on the submittals from the Engineer prior to shipment of equipment.



APPENDIX A

STANDARD ELECTRICAL DETAILS

DUCT BANKS

ESD3-7 Duct Bank Concrete Encased 1 Row Horizontal

GROUNDING

ESD7-1 Ground Connection Diagram
ESD7-2 Ground Connection to General Purpose XFMR
ESD7-3 Ground Connection Conduits at Electrical Equipment
ESD7-4 Ground Connection to Panelboard
ESD7-5 Ground Connection to Panelboard and Transformer
ESD7-10 Ground Connection to Equipment Mounting Pad
ESD7-12 Ground Connection to Equipment Mounting Steel with Riser
ESD7-25 Ground Connection to Building Steel
ESD7-30 Ground Connection for Wood Pole
ESD7-37 Ground Connection at Test Well
ESD7-38 Ground Connection to Cable Ground Rod
ESD7-40 Ground Connection Cable to Cable (Tee)

LIGHTING

ESD13-23 Fluorescent Luminaire Ceiling Mounted

HEAT TRACING

ESD28-3 Heat Tracing Standards
ESD28-5 Heat Tracing Standards
ESD28-6 Heat Tracing Standards
ESD28-7 Heat Tracing Standards
ESD28-8 Heat Tracing Standards
ESD28-13 Heat Tracing Standards

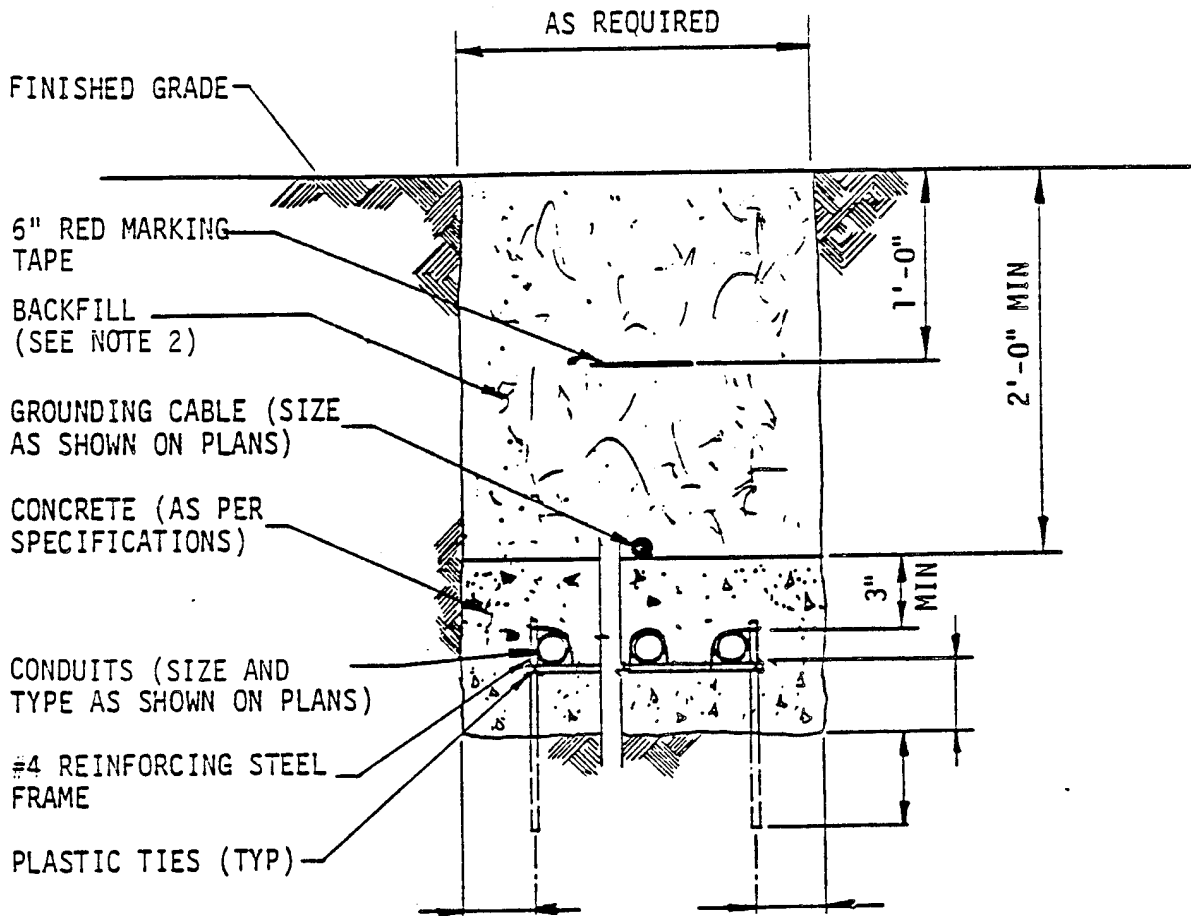

NOTES:

1. MINIMUM SEPARATION BETWEEN CONDUITS SHALL BE 3 INCHES.
2. USE ENGINEER APPROVED MATERIALS OBTAINED FROM: STOCKPILES OF EXCAVATED MATERIAL, BORROW AREAS, OR OFF-SITE LOCATIONS. IN AREAS WHERE THE TYPE OF BACKFILL IS NOT DESIGNATED, NATIVE BACKFILL MAY BE USED WITH THE ENGINEER'S PRIOR APPROVAL. BACKFILL SHALL BE COMPACTED TO 95% IN PLANT AREAS AND 85% IN OTHER AREAS AS PER ASTM D698.

MORRISON-KNUDSEN COMPANY, INC.

MORRISON-KNUDSEN COMPANY, INC.

			DRAWN BY <i>RFC</i>	APPROVED BY <i>K.A. PLL 04/20/81</i>	 <p>MORRISON-KNUDSEN COMPANY, INC.</p> <p>DUCT BANK CONCRETE ENCASED (1 HORIZONTAL ROW OF 1" TO 2" CONDUITS)</p> <p>TWO MORRISON-KNUDSEN PLAZA/P.O. BOX 7806/BOISE, ID. 83723</p>
			CHECKED BY <i>KHP</i>	SCALE	
			CONTRACT NUMBER 5000		
			SHEET NUMBER ESD3-17		
09/23/82	GENERAL REVISION	1	KHP		
DATE	REVISION OR ISSUE	NO.	BY		

GROUND ROD

ESD7
37

GROUND GRID
(SIZE AS SHOWN
ON PLANS)

ESD7
2 TRANSFORMER

ENCLOSURE

CONTROL, CABINETS

IF ENCLOSURES ARE
ADJACENT, LOOP
GROUND CONDUCTOR
THROUGH

ENCLOSURE

MOTOR CONTROL
CENTERS, LOAD
CENTERS, PANEL-
BOARDS, SUBSTA-
TIONS, SWITCH-
GEAR, ETC.

ESD7
3

GROUND BUS

LIGHTING & APPLIANCE
PANELBOARDS

GROUND BUS

ESD7
28 CABLE TRAY

MOTORS & EQUIPMENT

ESD7 6 ESD7 7 ESD7 8
ESD7 9 ESD7 11

ESD7 12 ESD7 13 ESD7 14
BUILDING STEEL

FENCE GROUND

ESD7 20 ESD7 21 ESD7 22 ESD7 23

ESD7 43 ESD7 44 ESD7 45
RAIL CONNECTIONS

GROUND GRID

ESD7
40

ESD7 38 ESD7 39

NOTE: ALL BELOW GRADE GROUND CONNECTIONS SHALL BE EXOTHERMIC TYPE.

MORRISON-KNUDSEN COMPANY, INC.

MORRISON-KNUDSEN COMPANY, INC.

DRAWN BY V.H.A. 10/10/78	APPROVED BY V.H.A. 10/10/78
CHECKED BY KB 9/28/78	SCALE
CONTRACT NUMBER 5000	
SHEET NUMBER ESD7-1	



MORRISON-KNUDSEN COMPANY, INC.

GROUND CONNECTION
GRID AND EQUIPMENT TAPS

DATE 09/16/81	REVISION OR ISSUE GENERAL REVISION	NO. 2	BY P.L.
------------------	---------------------------------------	----------	------------

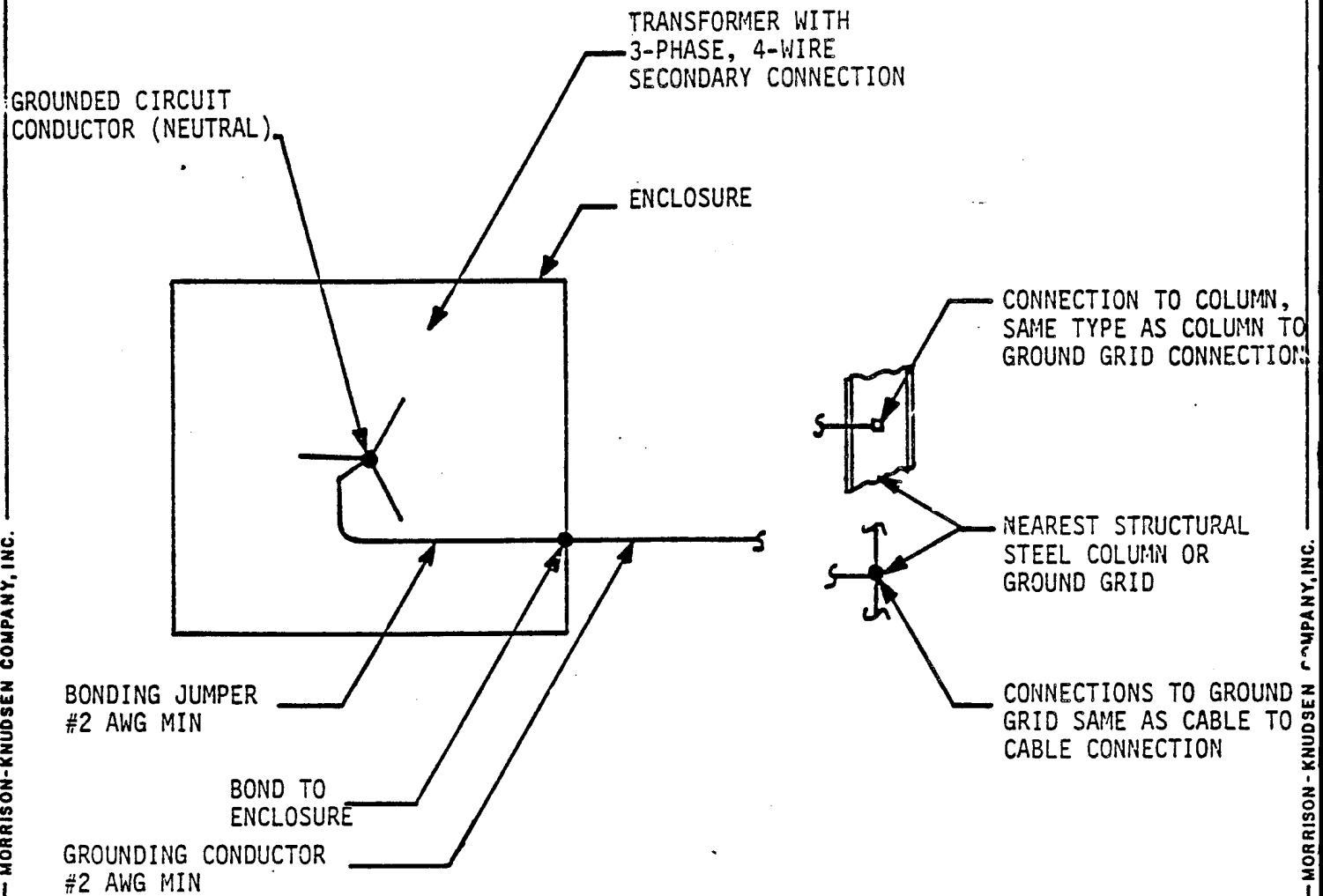

NOTE: COLUMN TO HAVE CABLE CONNECTION TO GROUND GRID.
 THIS CONNECTION APPLIES TO ALL GENERAL-PURPOSE TRANSFORMERS WITH AN IDENTIFIED GROUNDED CIRCUIT CONDUCTOR.

				DRAWN BY DVB	APPROVED BY K.E.A. <i>fall</i> 10/10/78	 MORRISON-KNUDSEN COMPANY, INC.
				CHECKED BY KB 9/26/78	SCALE	
				CONTRACT NUMBER 5000		GROUND CONNECTION TO GENERAL-PURPOSE TRANSFORMER
				SHEET NUMBER ESD7-2		
2/16/81	GENERAL REVISION	2	KB/K			
DATE	REVISION OR ISSUE	NO.	BY			

MORRISON-KNUDSEN COMPANY, INC.

MORRISON-KNUDSEN COMPANY, INC.

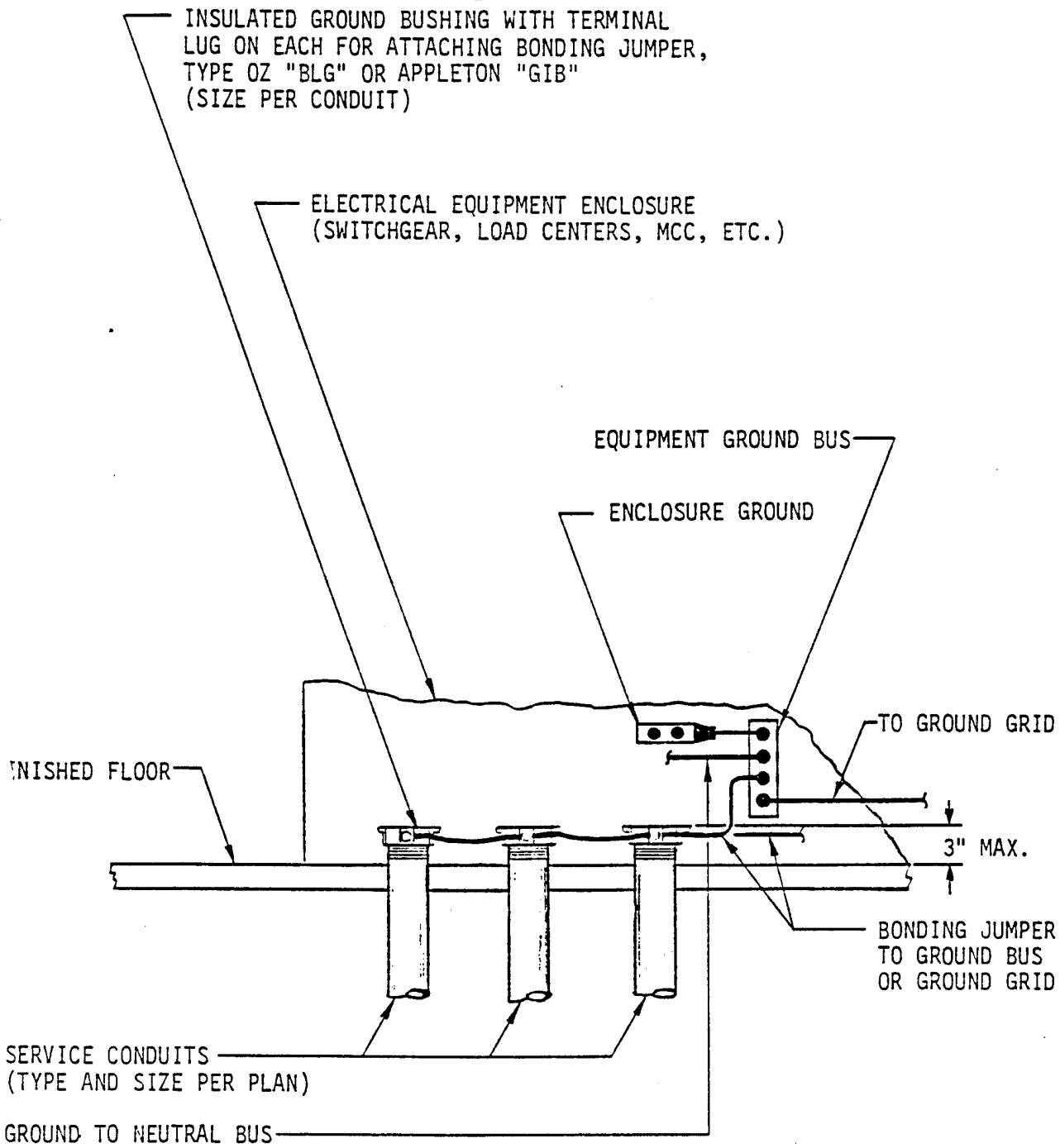

MORRISON-KNUDSEN COMPANY, INC.

MORRISON-KNUDSEN COMPANY, INC.

DATE	REVISION OR ISSUE	NO.	BY
07/28/33	GENERAL REVISION	2	kw/e

DRAWN BY K.A.A.	APPROVED BY K.A.A. 10/10/78
CHECKED BY KB 9/25/78	SCALE
CONTRACT NUMBER 5000	
SHEET NUMBER ESD7-3	

MORRISON-KNUDSEN COMPANY, INC.



GROUND CONNECTIONS
CONDUITS AT ELECTRICAL
EQUIPMENT

TWO MORRISON-KNUDSEN PLAZA/PO. BOX 7808/BOISE, ID. 83729

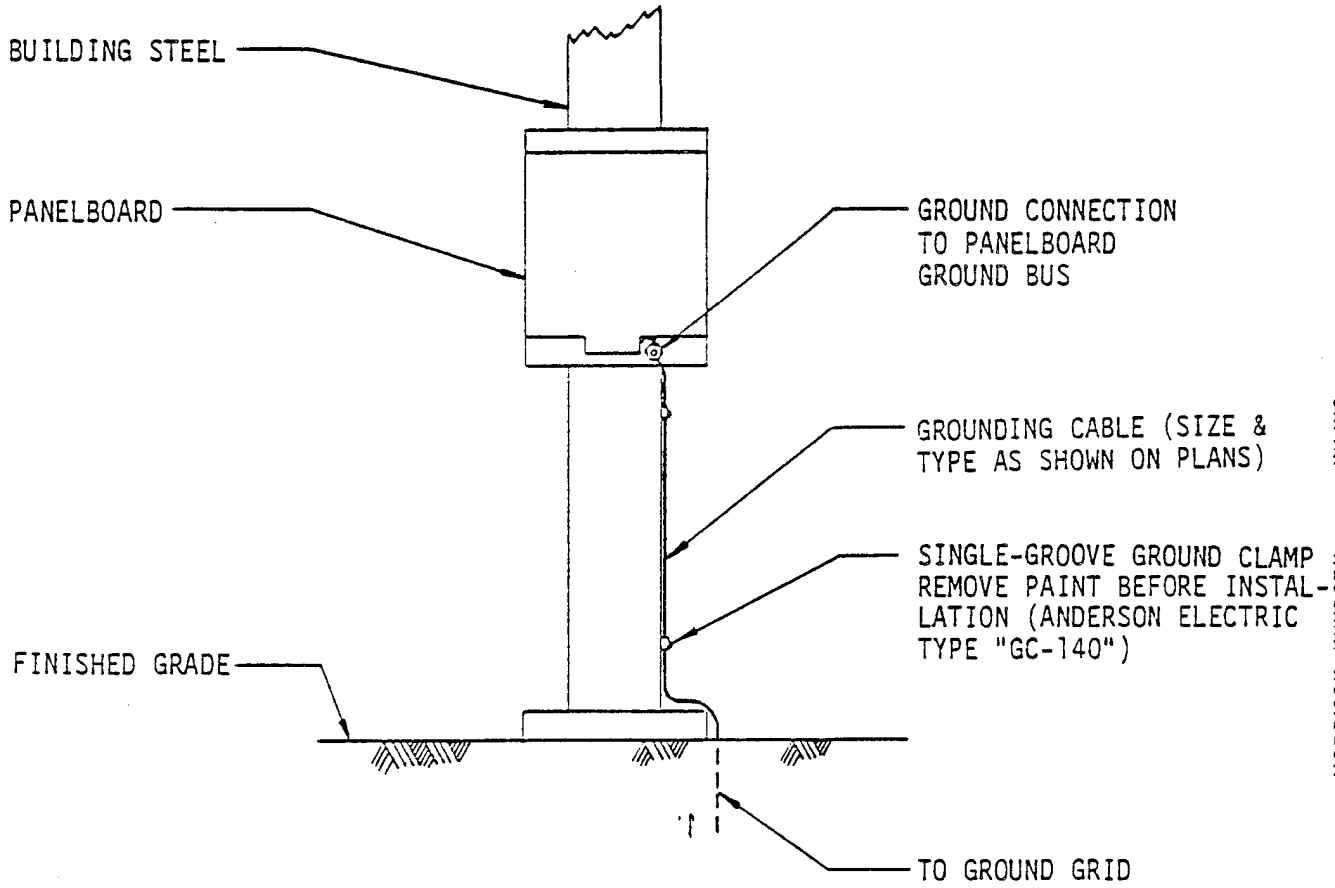

MORRISON-KNUDSEN COMPANY, INC.

MORRISON-KNUDSEN NY, INC.

GENERAL REVISION		
DATE	REVISION OR ISSUE	NO. BY

DRAWN BY R222	APPROVED BY ALVA LILL 10/10/78
CHECKED BY KB 9/22/78	SCALE
CONTRACT NUMBER 5000	
SHEET NUMBER ESD7-4	



MORRISON-KNUDSEN COMPANY, INC
GROUND CONNECTION
TO PANELBOARD
(COLUMN MOUNTED)

EQUIPMENT MOUNTING STEEL,
DRILL AS REQUIRED

SINGLE-GROOVE GROUND
CLAMP, SPACED 5'-0"
MAX O. C., REMOVE PAINT
BEFORE INSTALLATION
(ANDERSON ELECTRIC
TYPE "GC-140")

GROUNDING CABLE (SIZE &
TYPE AS SHOWN ON PLANS)

DOUBLE-GROOVE GROUND
CLAMP, REMOVE PAINT BEFORE
INSTALLATION (ANDERSON
ELECTRIC TYPE "GC-143")

9" APPROX

GRAVEL SURFACING
(AS SHOWN ON PLANS)

FINISHED GRADE

TO GROUND GRID

NOTE: GROUND CLAMPS SHALL BE SIZED ACCORDING TO MANUFACTURER'S SPECIFICATIONS FOR SIZE CABLE USED, AS SHOWN ON PLANS.

MORRISON-KNUDSEN COMPANY, INC.

MORRISON-KNUDSEN COMPANY, INC.

08/27/80	GENERAL REVISION	1	KB
DATE	REVISION OR ISSUE	NO.	BY

DRAWN BY K. H. A. [Signature]	APPROVED BY K. H. A. [Signature]
CHECKED BY KB 9/27/78	SCALE
CONTRACT NUMBER 5000	
SHEET NUMBER ESD7-10	

MORRISON-KNUDSEN COMPANY, INC.



GROUND CONNECTION
TO EQUIPMENT MOUNTING
STEEL WITH RISER
(BOLTED)

TWO MORRISON-KNUDSEN PLAZA/P.O. BOX 7806/BOISE, ID. 83729

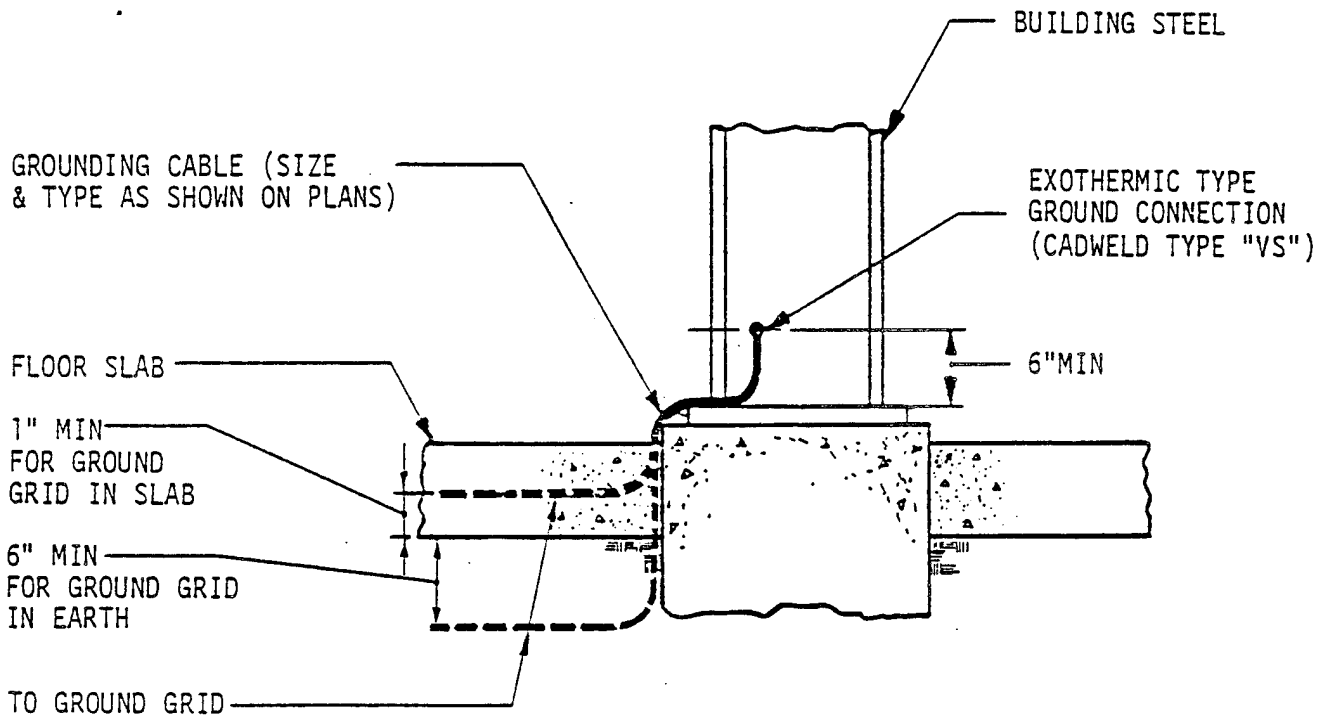

NOTE: EXOTHERMIC TYPE GROUND CONNECTION SHALL BE HEAVY-DUTY, SIZED ACCORDING TO THE MANUFACTURER'S SPECIFICATIONS FOR SIZE CABLE USED, AS SHOWN ON PLANS.

MORRISON-KNUDSEN COMPANY, INC.

MORRISON-KNUDSEN COMPANY, INC.

DATE	REVISION OR ISSUE	NO. BY
GENERAL REVISION 1/12/78		

DRAWN BY K.B.	APPROVED BY K.E.A.
CHECKED BY KB 9/28/78	SCALE
CONTRACT NUMBER 5000	
SHEET NUMBER ESD7-12	



MORRISON-KNUDSEN COMPANY, INC.

GROUND CONNECTION
TO BUILDING STEEL
(EXOTHERMIC)

1/4" STEEL CHECKERED FLOOR
 PLATE, 15" DIA. (CHECKERED
 SIDE UP), PAINT BOTTOM WITH
 TWO (2) COATS ASPHALT PAINT

2'-6" SQUARE, 6" THICK
 CONCRETE, AROUND HUB
 OF PIPE AT FINISHED
 GRADE

NO. 5 REINFORCING
 STEEL HANDLE, WELD
 BOTH ENDS TO 1/4"
 STEEL PLATE

FINISHED GRADE

CONCRETE COVER
 CAST IN PLACE

12" DIA. X 2'-0" STANDARD
 VITRIFIED CLAY PIPE
 WITH HUB

TWO (2) LAYERS
 OF SHEATING PAPER
 TO BE REMOVED
 AFTER CASTING

GROUND ROD
 (SIZE AS SPECIFIED)

GROUND CONNECTOR
 (BURNDY TYPE "GAR")

BARE GROUNDING CABLE
 (SIZE AS SHOWN ON PLANS)

TO GROUND GRID

MORRISON-KNUDSEN COMPANY, INC.

MORRISON-KNUDSEN COMPANY, INC.

DRAWN BY *[Signature]* APPROVED BY *[Signature]*
 V.H.A. 10/11/78

CHECKED BY *[Signature]* SCALE

CONTRACT NUMBER

5000

SHEET NUMBER

ESD7-30



MORRISON-KNUDSEN COMPANY, INC.

GROUND CONNECTION
 (SINGLE)
 AT TEST WELL

DATE	REVISION OR ISSUE	NO.	BY
10/11/78	GENERAL REVISION	1	

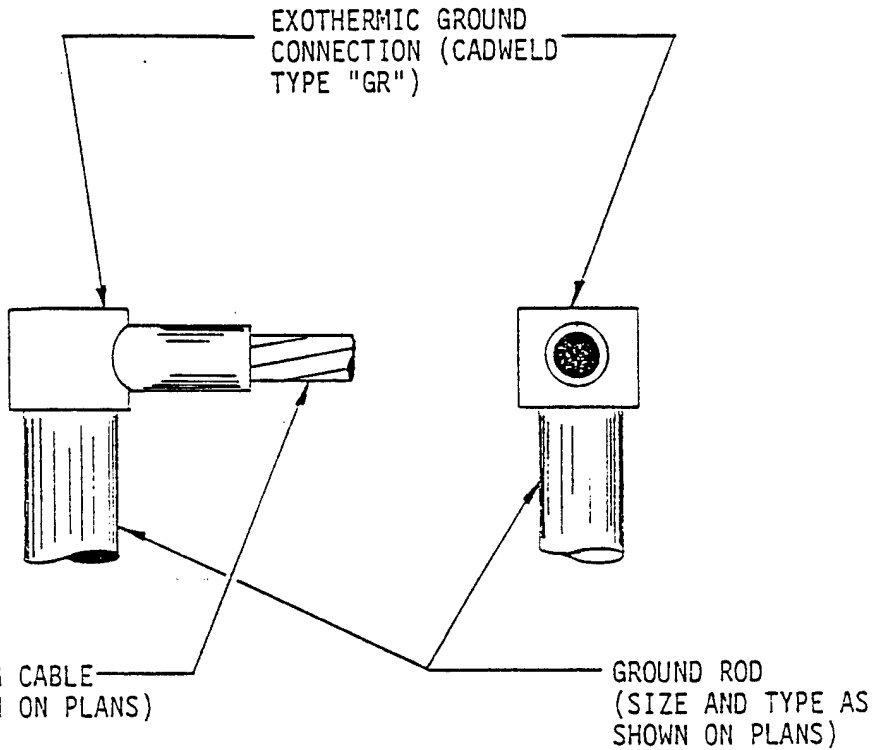

NOTE: EXOTHERMIC GROUND CONNECTION SHALL BE SIZED ACCORDING TO THE MANUFACTURER'S SPECIFICATIONS FOR SIZE CABLE AND ROD USED, AS SHOWN ON PLANS.

MORRISON-KNUDSEN COMPANY, INC.

MORRISON-KNUDSEN COMPANY, INC.

	DRAWN BY KHA	APPROVED BY KHA	DATE 10/11/75
	CHECKED BY KB	SCALE	
	CONTRACT NUMBER 5000		
	SHEET NUMBER 5007-37		
DATE	REVISION OR ISSUE	NO.	BY

MORRISON-KNUDSEN COMPANY, INC.



GROUND CONNECTION
CABLE TO GROUND ROD
(END)

NO MORRISON-KNUDSEN PLAZA/PO BOX 7808/805E 10 83729

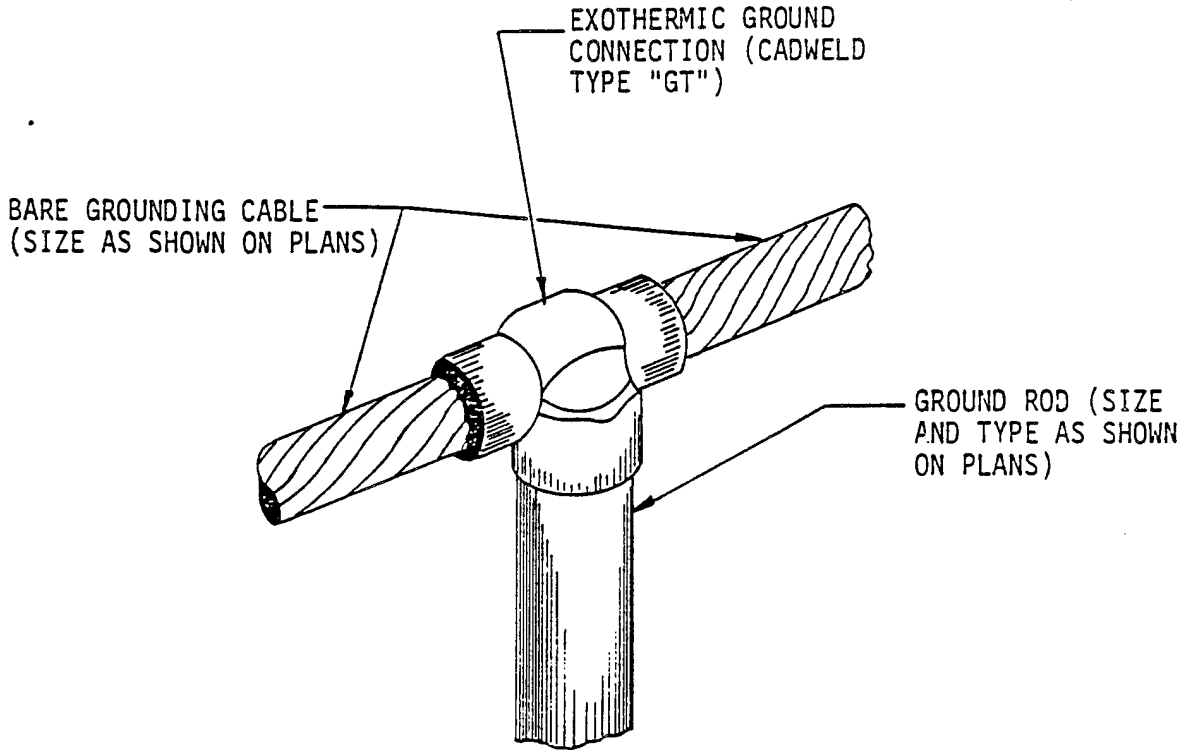

NOTE: EXOTHERMIC GROUND CONNECTIONS SHALL BE SIZED ACCORDING TO THE MANUFACTURER'S SPECIFICATIONS FOR SIZE CABLE AND ROD USED, AS SHOWN ON PLANS.

MORRISON-KNUDSEN COMPANY, INC.

MORRISON-KNUDSEN COMPANY, INC.

			DRAWN BY K.M.H.	APPROVED BY V.H.A. 10/11/78
			CHECKED BY KB 10/11/78	SCALE
			CONTRACT NUMBER 5000	
			SHEET NUMBER ESD7-38	
DATE	REVISION OR ISSUE	NO.	BY	



MORRISON-KNUDSEN COMPANY, INC.

GROUND CONNECTION
CABLE TO GROUND ROD
(TEE)

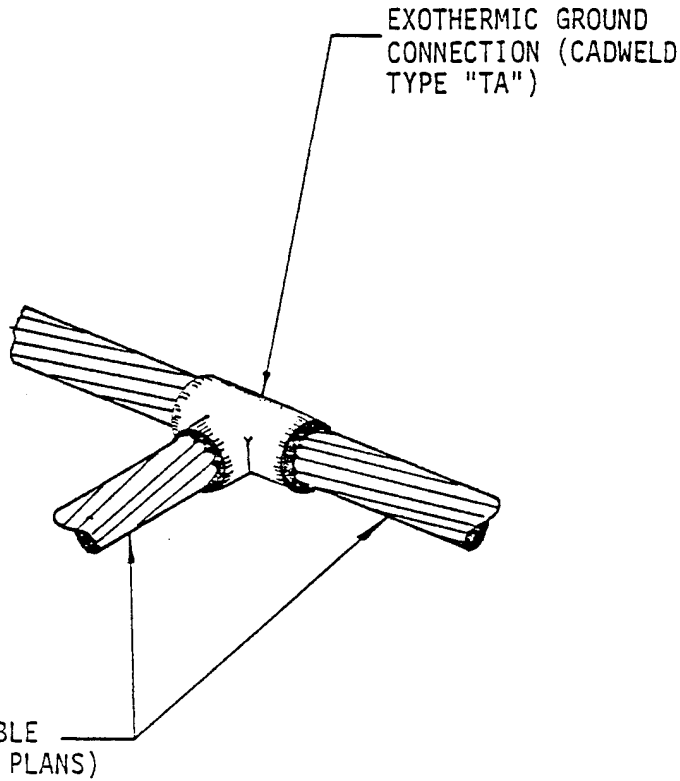



EXOTHERMIC GROUND CONNECTION (CADWELD TYPE "TA")

BARE GROUNDING CABLE (SIZE AS SHOWN ON PLANS)

NOTE: EXOTHERMIC GROUND CONNECTIONS SHALL BE SIZED ACCORDING TO THE MANUFACTURER'S SPECIFICATIONS FOR SIZE CABLE USED, AS SHOWN ON PLANS.

MORRISON-KNUDSEN COMPANY, INC.

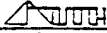
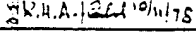
MORRISON-KNUDSEN COMPANY, INC.

DRAWN BY 		APPROVED BY 	MORRISON-KNUDSEN COMPANY, INC.
CHECKED BY KB 10/11/78	SCALE		
CONTRACT NUMBER 5000			 <p>GROUND CONNECTION CABLE TO CABLE (TEE)</p>
SHEET NUMBER			
DATE	REVISION OR ISSUE	NO. BY	TWO MORRISON-KNUDSEN PLAZA/PO BOX 7808/BOISE, ID 83729
		ESD7-40	

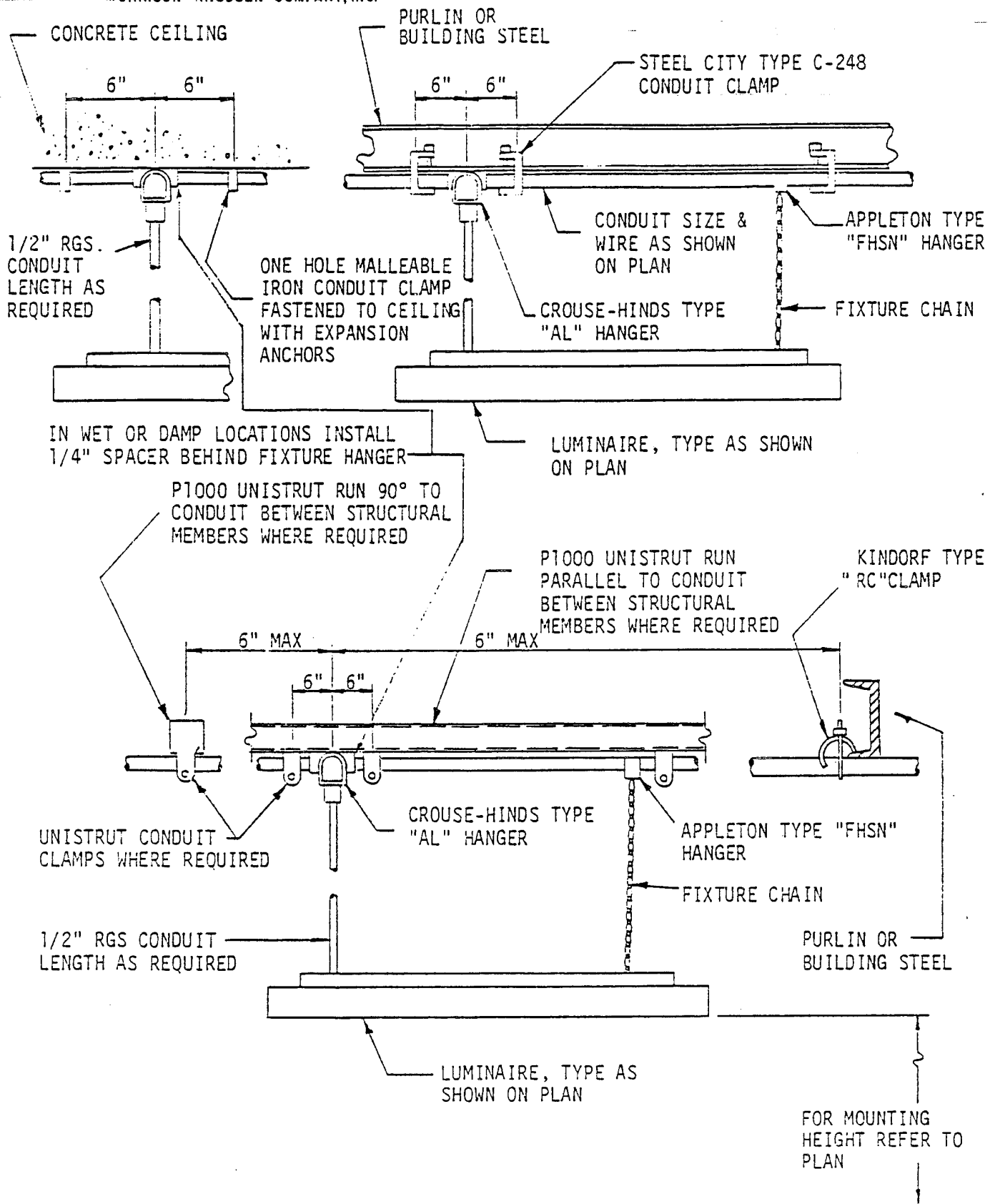

MORRISON-KNUDSEN COMPANY, INC.

MORRISON-KNUDSEN COMPANY, INC.

DATE	REVISION OR ISSUE	NO.	BY
		2	KHP

DRAWN BY RFK/SCHKO	APPROVED BY KHA
CHECKED BY KHP	SCALE
CONTRACT NUMBER 5000	
SHEET NUMBER ESD 13-23	

MORRISON-KNUDSEN COMPANY, INC.

MKO

FLUORESCENT LUMINAIRE
CEILING MOUNTED

TWO MORRISON-KNUDSEN PLAZA/PO BOX 7806 BOISE ID 83729

POLYESTER TAPE (TYP.)

ELECTRICAL HEAT TRACING CABLE

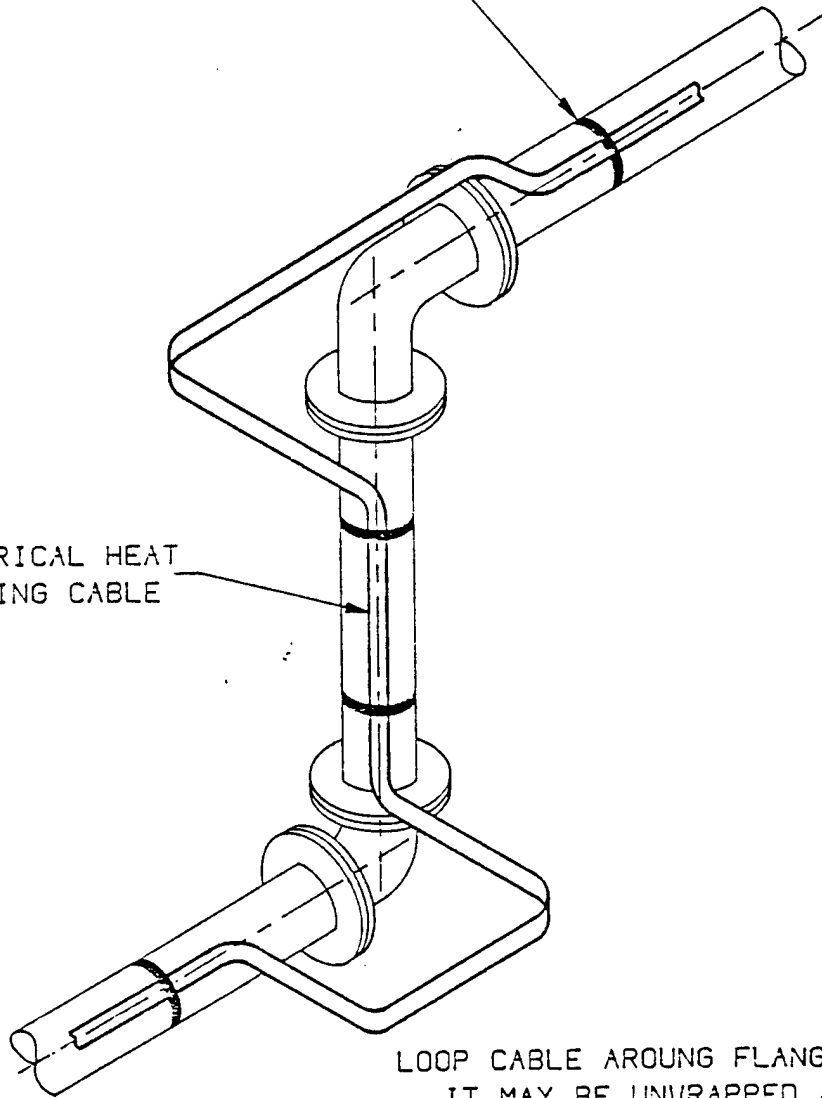

LOOP CABLE AROUND FLANGED ELBOW SO IT MAY BE UNWRAPPED AND ELBOW REMOVED WITHOUT CUTTING OR BREAKING CONTINUITY OF HEAT TRACING CABLE.

TYPICAL INSTALLATION OF FLANGED ELBOWS

G: TBLK: 1185

			DRAWN BY MIO	APPROVED BY V.A. [Signature]	 MORRISON-KNUDSEN COMPANY, INC. MINING GROUP
			CHECKED BY JEM	SCALE	
			CONTRACT NUMBER 5000		A
			SHEET NUMBER ESD28-3		REV 1
NO. APPROV.	DATE	REVISIONS	GENERAL REVISION		HEAT TRACING STANDARDS

G:TBLK11195

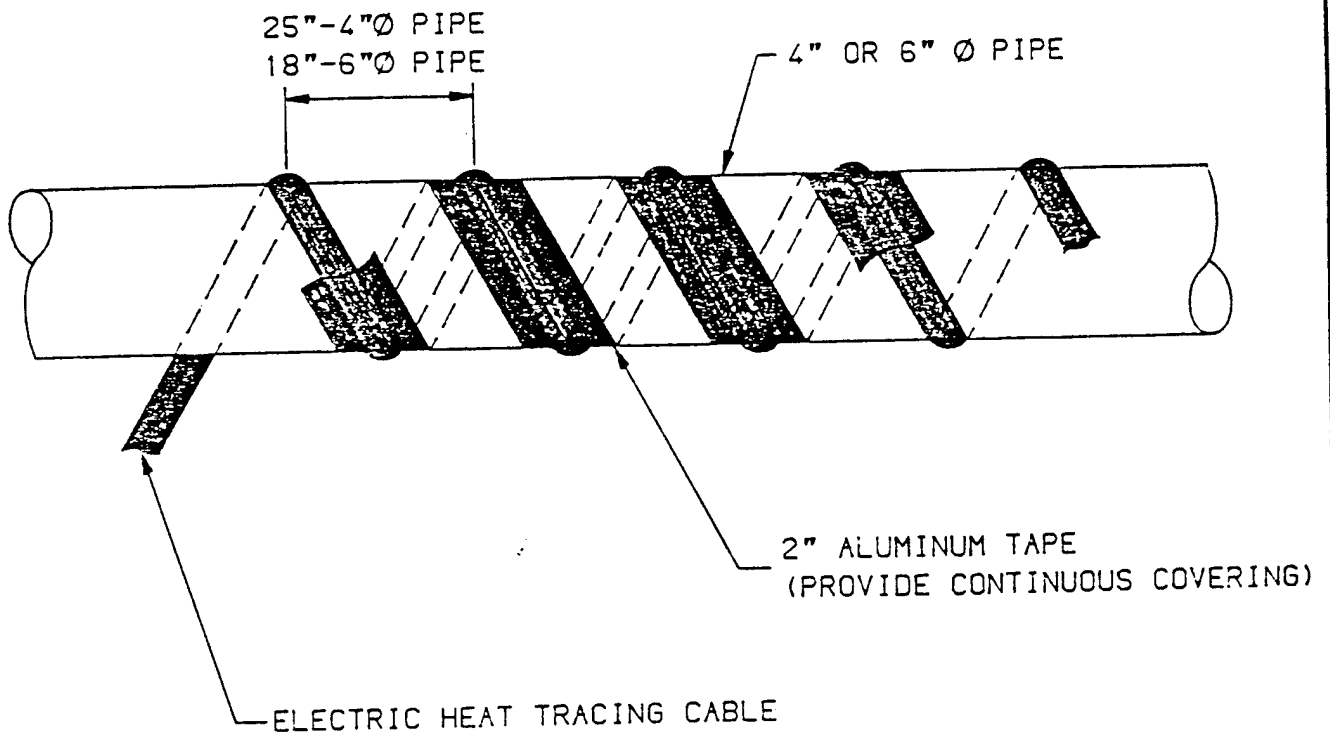

TYPICAL INSTALLATION ON LARGE PIPES

			DRAWN BY W.D.	APPROVED BY P.H.A. [Signature]	 MORRISON-KNUDSEN COMPANY, INC. MINING GROUP
			CHECKED BY JEM	SCALE	
			CONTRACT NUMBER 5000		A HEAT TRACING STANDARDS
			SHEET NUMBER ESD28-5		
NO.	APPROVED DATE		REVISIONS		REV 1

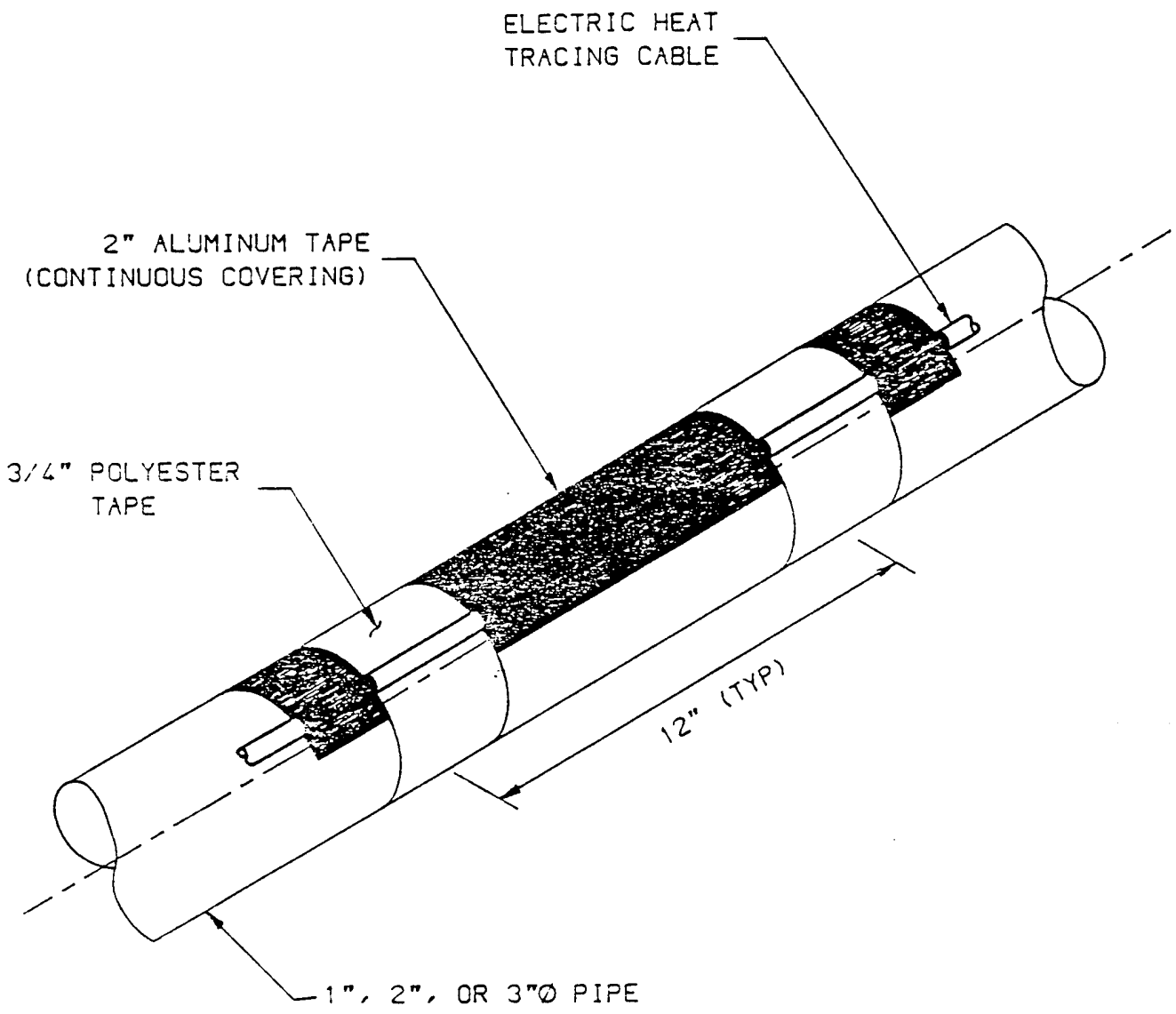

G:TBK:1185

TYPICAL INSTALLATION OF SMALL PIPES

			DRAWN BY <i>JEM</i>	APPROVED BY <i>J.A. K... 1/15/91</i>	 MORRISON-KNUDSEN COMPANY, INC. MINING GROUP
			CHECKED BY <i>JEM</i>	SCALE	
			CONTRACT NUMBER 5000		A REV 1
			SHEET NUMBER ESD28-6		
NO.	APVD	DATE	REVISIONS		HEAT TRACING STANDARDS
1			GENERAL REVISION		

G: TBLK1185

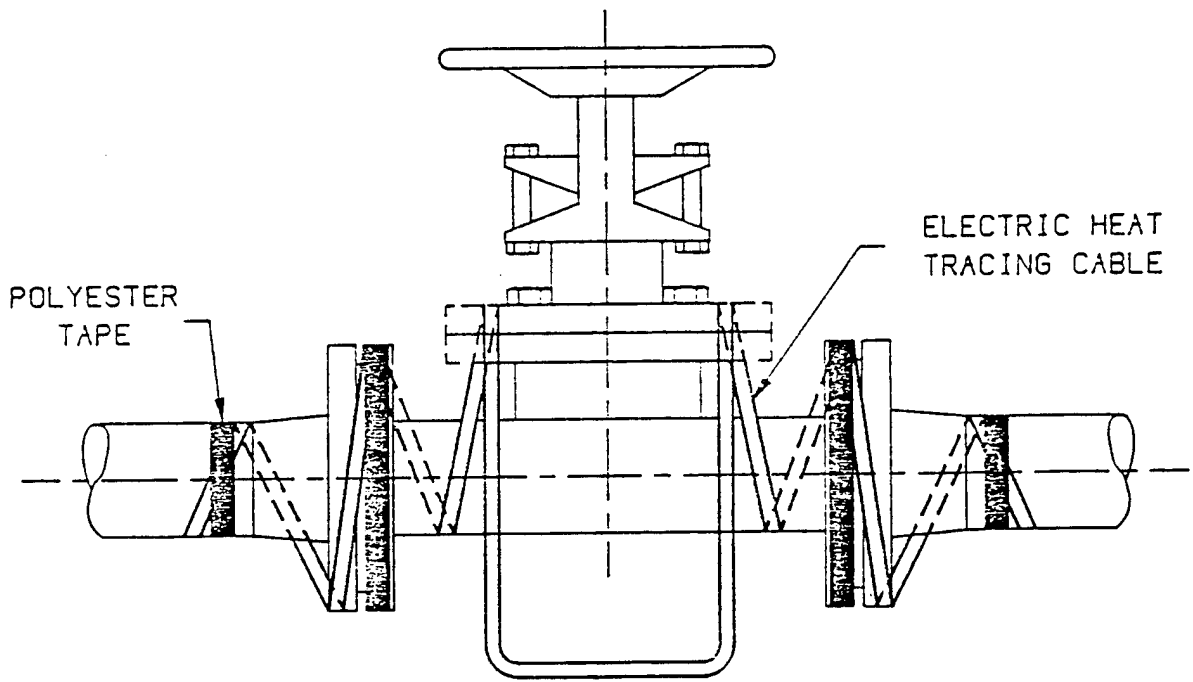

LOOP CABLE AROUND VALVE SO IT MAY BE UNWRAPPED AND VALVE REMOVED WITHOUT CUTTING OR BREAKING CONTINUITY OF HEAT TRACING CABLE.

TYPICAL INSTALLATION OF VALVES

		DRAWN BY JEM	APPROVED BY K. J. GILBERT	 MORRISON-KNUDSEN COMPANY, INC. MINING GROUP
		CHECKED BY JEM	SCALE	
		CONTRACT NUMBER 5000		HEAT TRACING STANDARDS REV A
		SHEET NUMBER ES028-7		
NO.	APPROVED	DATE	REVISIONS	

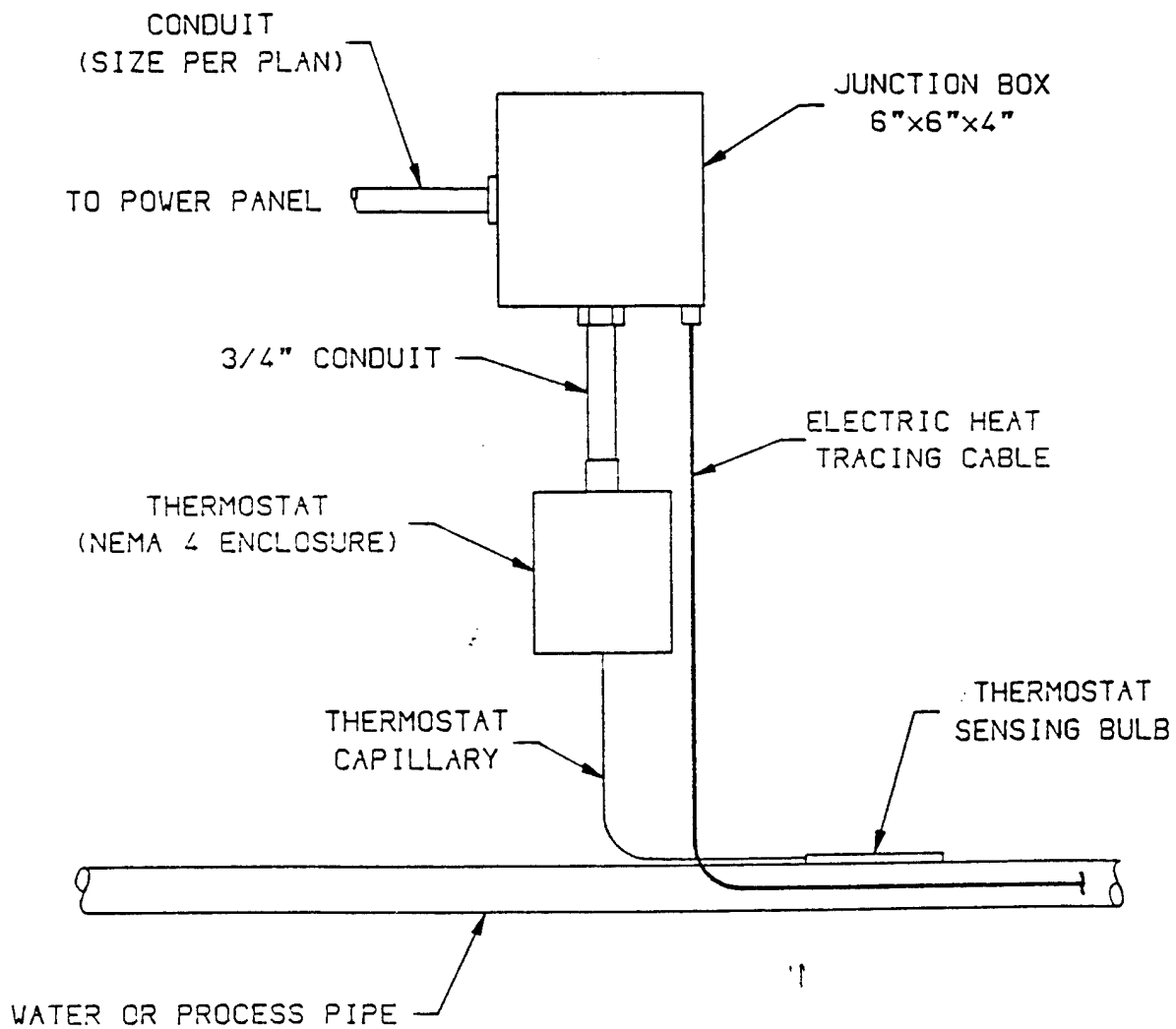

G:TBLK1185

TYPICAL INSTALLATION OF J-BOXES AND THERMOSTATS

		DRAWN BY JED		APPROVED BY K. A. B. 02/16/01	
		CHECKED BY JEM		SCALE	
		CONTRACT NUMBER 5000		A	
1		10/18/01		GENERAL REVISION	
NO.	APVD	DATE	REVISIONS		
			SHEET NUMBER ESD28-6		REV 1



MORRISON-KNUDSEN COMPANY, INC.
MINING GROUP

HEAT TRACING STANDARDS

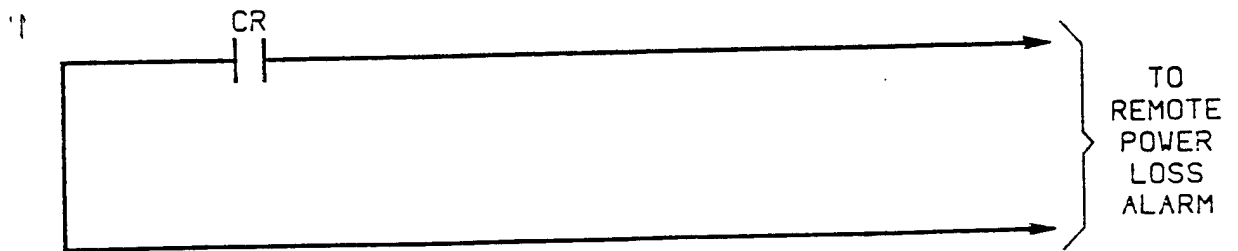
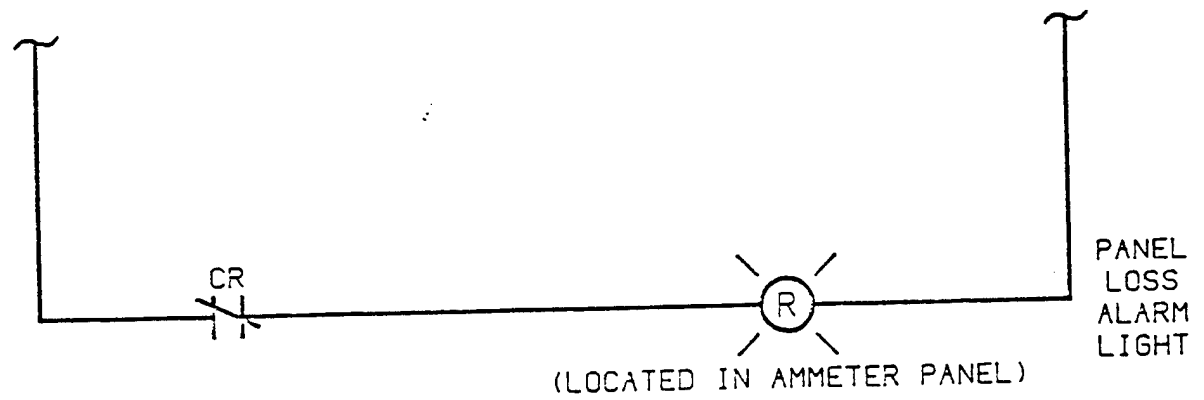
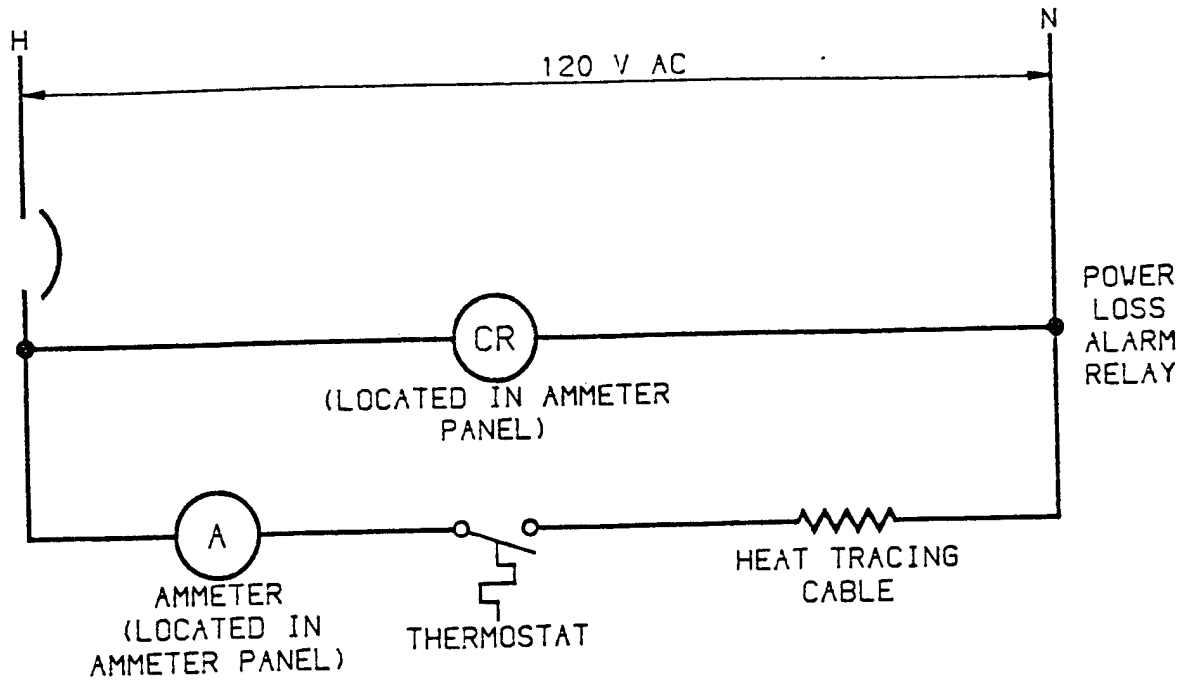

TYPICAL SCHEMATIC DIAGRAM

G:TBK1185

NO.	APPROV.	DATE	REVISIONS	DRAWN BY	APPROVED BY	 MORRISON-KNUDSEN COMPANY, INC. MINING GROUP
				JEM	SCALE	
GENERAL REVISION				CONTRACT NUMBER	A	HEAT TRACING STANDARDS
				5000	REV	
				SHEET NUMBER	1	
				FSD28-13		



APPENDIX B

ELECTRICAL PANEL SCHEDULES

LP-1	Metering Building
LP-2	Irondale Water Treatment Bldg
LP-3	Pole Mtd Irondale New Extraction Wells
LP-4	Pole Mtd Motor Pool Area
LP-5	Pole Mtd Motor Pool Area
LP-6	Pole Mtd Motor Pool Area

PANEL NUMBER :LP-1
 SERVICE :208/120V, 3PH, 4W
 LOCATION :METERING BLDG
 MOUNTING :SURFACE
 REF DWG. NO. :37-005

PROJECT :RAIL CLASS YARD & MOTOR POOL
 W.O. NO. : 2127
 ISSUE DRAWING NO. :SPEC 37-1601
 REVISION NO. :0
 ISSUE :FOR FINAL INPLEMENTATION

SUPPLY VOLTAGE (P TO P): 208
 SUPPLY VOLTAGE (P TO N): 120
 BUS RATING: 225

DES BY :CRH
 CHKD BY :JRM

DESCRIPTION	VA OR WATTS			BREAKER POLE A	CKT NO.	BUS CONN.	CKT NO.	BREAKER POLE A	VA OR WATTS			DESCRIPTION
	A	B	C						A	B	C	
RECEPTACLES	540	--	--	1-20A**	1	-*-----	2		1670	--	--	
LIGHTING	--	600	--	1-20A**	3	-----*	4	3-20A	--	1670	--	UNIT HEATER
HEAT TRACE	--	--	150	1-20A*	5	-----*	6		--	--	1670	
SPARE	--	--	--	1-20A	7	-*-----	8	1-20A	--	--	--	SPARE
SPARE	--	--	--	1-20A	9	-----*	10	1-20A	--	--	--	SPARE
SPARE	--	--	--	1-20A	11	-----*	12	1-20A	--	--	--	SPARE
SPARE	--	--	--		13	-*-----	14		--	--	--	
	--	--	--		15	-----*	16		--	--	--	
	--	--	--		17	-----*	18		--	--	--	
	--	--	--		19	-*-----	20		--	--	--	
	--	--	--		21	-----*	22		--	--	--	
	--	--	--		23	-----*	24		--	--	--	NOTES:
	--	--	--		25	-*-----	26		--	--	--	*GFI CIRCUIT BREAKER
	--	--	--		27	-----*	28		--	--	--	HEAT TRACE GFI BREAKER
	--	--	--		29	-----*	30		--	--	--	TO HAVE 30ma SENSITIVITY
	--	--	--		31	-*-----	32		--	--	--	** GFI CIRCUIT BREAKER
	--	--	--		33	-----*	34		--	--	--	TO HAVE 5ma SENSITIVITY
	--	--	--		35	-----*	36		--	--	--	
	--	--	--		37	-*-----	38		--	--	--	BRANCH BREAKER: BOLT ON
	--	--	--		39	-----*	40		--	--	--	
	--	--	--		41	-----*	42		--	--	--	

TOTAL (1) | 540 600 150 | TOTAL (2) | 1670 1670 1670 |

TOTAL (2) | 1670 1670 1670 |

TOTALS WATTS PHASE A: 2210
 TOTALS WATTS PHASE B: 2270
 TOTALS WATTS PHASE C: 1820

PHASE A CURRENT: 18.4
 PHASE B CURRENT: 18.9
 PHASE C CURRENT: 15.2

TOTAL PANEL CURRENT: 18.9
 TOTAL PANEL KVA: 6.8

MAIN LUGS :

MAIN BREAKER :100A
 FEEDER ENTRANCE :BOTTOM
 FEEDER SIZE :3#1 & 1#6G
 SOURCE :NEW 30 KVA TRANSFORMER
 SHORT CIRCUIT RATING A :22,000 AIC

NOTES :SEE NOTES ABOVE

:
 :

PANEL NUMBER :LP-2
 SERVICE :208/120V, 3PH, 4W
 LOCATION :IRONDALE WT BLDG
 MOUNTING :SURFACE
 REF DWG. NO. :37-002C

PROJECT :RAIL CLASS YARD & MOTOR POOL
 W.O. NO. : 2127
 ISSUE DRAWING NO. :SPEC 37-1601
 REVISION NO. :0
 ISSUE :FOR FINAL IMPLEMENTATION

SUPPLY VOLTAGE (P TO P): 208
 SUPPLY VOLTAGE (P TO N): 120
 BUS RATING: 225

DES BY :CRH
 CHKD BY :JRM

DESCRIPTION	VA OR WATTS			BREAKER POLE A	CKT NO.	BUS CONN.	CKT NO.	BREAKER POLE A	VA OR WATTS			DESCRIPTION
	A	B	C						A	B	C	
HEAT TRACE HT-1 (TC-502)	300	--	--	1-20A*	1	-*----	2	1-20A*	300	--	--	HEAT TRACING HT-2 (TC-501)
HEAT TRACING HT-1A	--	300	--	1-20A*	3	-----	4	1-20A*	--	300	--	HEAT TRACING HT-3
LCV-201 FAIL SAFE CONTROL	--	--	600	1-20A	5	-----*	6	1-20A	--	--	100	LSL-201/LSH-201/LSHH-201
FCV-103 FAIL SAFE CONTROL	600	--	--	1-20A	7	-*----	8	1-20A*	450	--	--	HEAT TRACING HT-4 (TC-500)
LSL/LSH/LSHH-500	--	150	--	1-20A	9	-----*	10	1-20A	--	1300	--	WELL CONT PNL 1DWRW1 & 2
WELL CONT PNL P-104/105	--	--	350	1-20A	11	-----*	12	1-20A	--	--	350	WELL CONT PNL P-501/02/03
INSTRUMENT CONTROL PANEL	150	--	--	1-20A	13	-*----	14	1-15A	450	--	--	WELL CONT PNL R1S
WELL CONT PNL R1C	--	200	--	1-15A	15	-----*	16	1-15A	--	350	--	WELL CONT PNL R2N
WELL CONT PNL R1N	--	--	200	1-15A	17	-----*	18	1-15A	--	--	550	WELL CONT PNL R2S
WELL CONT PNL R2C	150	--	--	1-15A	19	-*----	20	1-15A	150	--	--	WELL CONT PNL NEW
SPARE	--	150	--	1-15A	21	-----*	22	1-15A	--	150	--	WELL CONT PNL SEW
	--	--	--		23	-----*	24		--	--	--	
	--	--	--		25	-*----	26		--	--	--	
	--	--	--		27	-----*	28		--	--	--	NOTES:
	--	--	--		29	-----*	30		--	--	--	* GFI CIRCUIT BREAKER
	--	--	--		31	-*----	32		--	--	--	HEAT TRACE GFI BRKR TO
	--	--	--		33	-----*	34		--	--	--	HAVE 30 ma SENSITIVITY
	--	--	--		35	-----*	36		--	--	--	
	--	--	--		37	-*----	38		--	--	--	BRANCH BREAKER: BOLT-ON
	--	--	--		39	-----*	40		--	--	--	
	--	--	--		41	-----*	42		--	--	--	

TOTAL (1) | 1200 800 1150 |

TOTAL (2) | 1350 2100 1000 |

TOTAL (2) | 1350 2100 1000 |

TOTALS WATTS PHASE A: 2550
 TOTALS WATTS PHASE B: 2900
 TOTALS WATTS PHASE C: 2150

PHASE A CURRENT: 21.3
 PHASE B CURRENT: 24.2
 PHASE C CURRENT: 17.9

TOTAL PANEL CURRENT: 24.2
 TOTAL PANEL KVA: 8.7

MAIN LUGS :

MAIN BREAKER :100A
 FEEDER ENTRANCE :BOTTOM
 FEEDER SIZE :4#2 & 1#2G
 SOURCE :NEW 30KVA TRANSFORMER
 SHORT CIRCUIT RATING A :22,000 AIC

NOTES :SEE ABOVE FOR NOTES
 :
 :

PANEL NUMBER :LP-3
 SERVICE :240/120V, 3PH, 4W
 LOCATION :POLE MOUNTED
 MOUNTING :SURFACE
 REF DWG. NO. :37-006B

PROJECT :IRONDALE EXTRACTION WELLS
 W.O. NO. : 2127
 ISSUE DRAWING NO. :SPEC 37-1601
 REVISION NO. :1 1/11/91
 ISSUE :REVISED IRONDALE SYSTEM WELLS

SUPPLY VOLTAGE (P TO P): 240
 SUPPLY VOLTAGE (P TO N): 120
 BUS RATING: 225

DES BY :CRH
 CHKD BY :JRM

DESCRIPTION	VA OR WATTS			IBREAKER	ICKT	BUS	CKT	IBREAKER	VA OR WATTS			DESCRIPTION	
	A	B	C						IPOLE A	IND. CONN.	NO.		IPOLE A
PU-511 (5 HP)	3648	—	—		1	1	2		6000	—	—		
	—	3648	—		3	4	13-50A		—	6000	—		PU-513 (10HP)
	—	—	3648		5	6			—	—	6000		
	6000	—	—		7	8			6000	—	—		
PU-512 (10HP)	—	6000	—		9	10	13-50A		—	6000	—		PU-514 (10HP)
	—	—	6000		11	12			—	—	6000		
	—	—	—		13	14			—	—	—		
SPARE	—	—	—		15	16	13-50A		—	—	—		SPARE
	—	—	—		17	18			—	—	—		
HEAT TRACE 4"-RGW-PVC-511	300	—	—		19	20	11-20A*		300	—	—		HEAT TRACE 4"-RGW-PVC-513
BLANK	—	—	—		21	22			—	—	—		BLANK
SPARE	—	—	—		23	24	11-20A*		—	—	—		SPARE
HEAT TRACE 4"-RGW-PVC-512	300	—	—		25	26	11-20A*		300	—	—		HEAT TRACE 4"-RGW-PVC-514
	—	—	—		27	28			—	—	—		NOTE
	—	—	—		29	30			—	—	—		8 LEG 208V TO GND MUST NOT
	—	—	—		31	32			—	—	—		BE USED FOR ANYTHINS BUT
	—	—	—		33	34			—	—	—		240V, 3PH PWR
	—	—	—		35	36			—	—	—		* GFI CKT BREAKER
	—	—	—		37	38			—	—	—		HEAT TRACE GFI BRKR TO
	—	—	—		39	40			—	—	—		HAVE 30 ma SENSITIVITY
	—	—	—		41	42			—	—	—		BRANCH BREAKER: BOLT-ON

TOTAL (1) | 10248 9648 9948 |

TOTAL (2) | 12600 12000 12000 |

TOTAL (2) | 12600 12000 12000 |

TOTALS WATTS PHASE A: 22848
 TOTALS WATTS PHASE B: 21648
 TOTALS WATTS PHASE C: 21948

PHASE A CURRENT: 190.4
 PHASE B CURRENT: 180.4
 PHASE C CURRENT: 182.9

TOTAL PANEL CURRENT: 165.1
 TOTAL PANEL KVA: 68.5

MAIN LUGS :

MAIN BREAKER :200A
 FEEDER ENTRANCE :TOP
 FEEDER SIZE :4#1/0 & 1#6G
 SOURCE :NEW 30 KVA TRANSFORMER
 SHORT CIRCUIT RATING A :22,000 AIC

NOTES :SEE ABOVE FOR NOTES

:
 :

PANEL NUMBER :LP-4
 SERVICE :240/120V, 3PH, 4W
 LOCATION :POLE MOUNTED
 MOUNTING :SURFACE
 REF DWG. NO. :37-006A

PROJECT :IRONDALE EXTRACTION WELLS
 W.O. NO. : 2127
 ISSUE DRAWING NO. :SPEC 37-1601
 REVISION NO. :0
 ISSUE :FOR FINAL IMPLEMENTATION

SUPPLY VOLTAGE (P TO P): 240
 SUPPLY VOLTAGE (P TO N): 120
 BUS RATING: 225

DES BY :CRH
 CHKD BY :JRM

DESCRIPTION	VA OR WATTS			BREAKER POLE A	CKT NO.	BUS CONN.	CKT NO.	BREAKER POLE A	VA OR WATTS			DESCRIPTION	
	A	B	C						A	B	C		
MPDW1 (3HP)	2304	--	--	3-20A	1	----	2	3-20A	2304	--	--	MPDW2 (3HP)	
	--	2304	--		3	----	4		--	2304	--		
	--	--	2304		5	----	6		--	--	2304		--
	--	--	--		7	----	8		--	--	--		--
SPARE	--	--	--	3-20A	9	----	10	3-20A	--	--	--	SPARE	
	--	--	--		11	----	12		--	--	--		
	--	--	--		13	----	14		--	--	--		
	--	--	--		15	----	16		--	--	--		NOTE:
	--	--	--		17	----	18		--	--	--		B LEG 208V TO GND MUST
	--	--	--		19	----	20		--	--	--		NOT BE USRD FOR ANYTHING
	--	--	--		21	----	22		--	--	--		BUT 240V, 3PH PWR
	--	--	--		23	----	24		--	--	--		* GFI CKT BREAKER
	--	--	--		25	----	26		--	--	--		HEAT TRACE GFI BRKRS TO
	--	--	--		27	----	28		--	--	--		HAVE 30 ma SENSITIVITY
	--	--	--		29	----	30		--	--	--		
	--	--	--		31	----	32		--	--	--		BRANCH BREAKER: BOLT-ON
	--	--	--	33	----	34	--	--	--				
	--	--	--	35	----	36	--	--	--				
	--	--	--	37	----	38	--	--	--				
	--	--	--	39	----	40	--	--	--				
	--	--	--	41	----	42	--	--	--				

TOTAL (1) | 2304 2304 2304 |

TOTAL (2) | 2304 2304 2304 |

TOTAL (2) | 2304 2304 2304 |

TOTALS WATTS PHASE A: 4608
 TOTALS WATTS PHASE B: 4608
 TOTALS WATTS PHASE C: 4608

MAIN LUGS :

MAIN BREAKER :100A
 FEEDER ENTRANCE :TOP
 FEEDER SIZE :3#1 & 1#6G
 SOURCE :NEW 30 KVA TRANSFORMER
 SHORT CIRCUIT RATING A :22,000 AIC

PHASE A CURRENT: 38.4
 PHASE B CURRENT: 38.4
 PHASE C CURRENT: 38.4
 TOTAL PANEL CURRENT: 33.3
 TOTAL PANEL KVA: 13.8

NOTES :SEE ABOVE FOR NOTES
 :
 :

PANEL NUMBER :LP-5
 SERVICE :240/120V, 3PH, 4W
 LOCATION :POLE MOUNTED
 MOUNTING :SURFACE
 REF DWG. NO. :37-006A

PROJECT :IRONDALE EXTRACTION WELLS
 W.O. NO. : 2127
 ISSUE DRAWING NO. :SPEC 37-1601
 REVISION NO. :0
 ISSUE :FOR FINAL IMPLEMENTATION

SUPPLY VOLTAGE (P TO P): 240
 SUPPLY VOLTAGE (P TO N): 120
 BUS RATING: 225

DES BY :CRH
 CHKD BY :JRM

DESCRIPTION	VA OR WATTS			BREAKER POLE A	CKT NO.	BUS CONN.	CKT NO.	BREAKER POLE A	VA OR WATTS			DESCRIPTION	
	A	B	C						A	B	C		
RYDW6 (5HP)	3648	--	--	3-30A	1	*	2	3-30A	3648	--	--	RYDW7 (5HP)	
	--	3648	--		3	----	4		5	--	3648		--
	--	--	3648		5	----	6		7	--	--		3648
SPARE	--	--	--	3-30A	9	*	10	3-30A	--	--	--	SPARE	
	--	--	--		11	----	12		13	--	--		--
	--	--	--		15	----	16		17	--	--		--
	--	--	--		19	----	20		21	--	--		--
	--	--	--		23	----	24		25	--	--		--
	--	--	--		27	----	28		29	--	--		--
	--	--	--		31	----	32		33	--	--		--
	--	--	--		35	----	36		37	--	--		--
	--	--	--		39	----	40		41	--	--		--
	--	--	--		41	----	42			--	--		--

NOTES:
 B LEG 208V TO GND MUST
 NOT BE USED FOR ANYTHING
 BUT 240V, 3PH PWR
 * GFI CKT BREAKER
 HEAT TRACE GFI BKRS TO
 HAVE 30 ma SENSITIVITY
 BRANCH BREAKER: BOLT-ON

TOTAL (1) | 3648 3648 3648 |

TOTAL (2) | 3648 3648 3648 |

TOTAL (2) | 3648 3648 3648 |

TOTALS WATTS PHASE A: 7296
 TOTALS WATTS PHASE B: 7296
 TOTALS WATTS PHASE C: 7296

PHASE A CURRENT: 60.8
 PHASE B CURRENT: 60.8
 PHASE C CURRENT: 60.8

TOTAL PANEL CURRENT: 52.7
 TOTAL PANEL KVA: 21.9

MAIN LUGS :

MAIN BREAKER :100A
 FEEDER ENTRANCE :TOP
 FEEDER SIZE :3#1 & 1#6G
 SOURCE :NEW 30 KVA TRANSFORMER
 SHORT CIRCUIT RATING A :22,000 AIC

NOTES :SEE ABOVE FOR NOTES
 :
 :

PANEL NUMBER :LP-6
 SERVICE :240/120V, 3PH, 4W
 LOCATION :POLE MOUNTED
 MOUNTING :SURFACE
 REF DWG. NO. :37-006A

PROJECT :IRONDALE EXTRACTION WELLS
 W.O. NO. : 2127
 ISSUE DRAWING NO. :SPEC 37-1601
 REVISION NO. :0
 ISSUE :FOR FINAL IMPLEMENTATION

SUPPLY VOLTAGE (P TO P): 240
 SUPPLY VOLTAGE (P TO N): 120
 BUS RATING: 225

DES BY :CRH
 CHKD BY :JRM

DESCRIPTION	VA OR WATTS			BREAKER POLE A	CKT NO.	BUS CONN.	CKT NO.	BREAKER POLE A	VA OR WATTS			DESCRIPTION	
	A	B	C						A	B	C		
RYDW1 (3HP)	2304	--	--	3-20A	1	-*	2	3-20A	2304	--	--	RYDW2 (3HP)	
	--	2304	--		3	---	4		3-20A	--	2304		--
	--	--	2304		5	---	6			--	--		2304
RYDW3 (3HP)	2304	--	--	3-20A	7	-*	8	3-20A	2304	--	--	RYDW4 (3HP)	
	--	2304	--		9	---	10		3-20A	--	2304		--
	--	--	2304		11	---	12			--	--		2304
RYDW5 (3HP)	2304	--	--	3-20A	13	-*	14	3-20A	--	--	--	SPARE	
	--	2304	--		15	---	16		3-20A	--	--		--
	--	--	2304		17	---	18			--	--		--
SPARE	--	--	--	3-20A	19	-*	20		--	--	--	NOTES: B LEG 208V TO GND MUST NOT BE USED FOR ANYTHING BUT 240V, 3PH PWR * GFI CKT BREAKER HEAT TRACE GFI BKRS TO HAVE 30 ma SENSITIVITY BRANCH BREAKER: BOLT ON	
	--	--	--		21	---	22			--	--		--
	--	--	--		23	---	24			--	--		--
	--	--	--		25	-*	26			--	--		--
	--	--	--		27	---	28			--	--		--
	--	--	--		29	---	30			--	--		--
	--	--	--		31	-*	32			--	--		--
	--	--	--		33	---	34			--	--		--
	--	--	--	35	---	36		--	--	--			
	--	--	--	37	-*	38		--	--	--			
	--	--	--	39	---	40		--	--	--			
	--	--	--	41	---	42		--	--	--			

TOTAL (1) | 6912 6912 6912 |

TOTAL (2) | 4608 4608 4608 |

TOTAL (2) | 4608 4608 4608 |

TOTALS WATTS PHASE A: 11520
 TOTALS WATTS PHASE B: 11520
 TOTALS WATTS PHASE C: 11520

PHASE A CURRENT: 96.0
 PHASE B CURRENT: 96.0
 PHASE C CURRENT: 96.0

TOTAL PANEL CURRENT: 83.2
 TOTAL PANEL KVA: 34.6

MAIN LUGS :

MAIN BREAKER :150A
 FEEDER ENTRANCE :TOP
 FEEDER SIZE :3#1 & 1#6G
 SOURCE :NEW 30 KVA TRANSFORMER
 SHORT CIRCUIT RATING A :22,000 AIC

NOTES :SEE ABOVE FOR NOTES
 :
 :

VENDOR DATA REQUIREMENTS ELECTRICAL

SPECIFICATION NUMBER: 37-1601

EQUIPMENT: All Electrical Equipment

The following data shall be furnished in the quantities indicated. Review copies shall be submitted 2 weeks after receipt of order; certified copies shall be submitted 4 weeks prior to shipment, unless noted otherwise. Transparencies are not required for drawing size 8 1/2" x 11".

Drawings and Data Required	Data With Bid	Review Copies		Certified Copies		Remarks
		Prints	Transparencies	Prints	Transparencies	
1. ELECTRICAL EQUIPMENT ASSEMBLIES						
2. Dimensional Outlines		6	1	6	1	
3. Plan Arrangements		6	1	6	1	
4. Foundation Loading/Weights						
5. Stubup Plans						
6. Clearance Requirements						
7.						
8. ELECTRICAL DETAILS						
9. Equipment Details	4	6	1	6	1	
10. Mounting Details		6	1	6	1	
11. Cross-Sectional Drawings		6	1	6	1	
12.						
13. ELECTRICAL WIRING						
14. Schematic Diagrams		6	1	6	1	
15. Wiring Diagrams		6	1	6	1	
16. Interconnecting Diagrams		6	1	6	1	
17. Switch Sequence Schedules						
18.						
19. ELECTRICAL REFERENCE MATERIAL						
20. General Description	4	6		6		
21. Performance Data	4	6		6		
22. Parts List		6		6		
23. Install, Operate & Maintain Manuals		6		6		
24. Relay Operating Curves and Description		6		6		
25. Circuit Breaker Operating Curves		6		6		
26. Fuse Time Current Curves						
27. Bills of Material		6		6		
28. Certified Test Reports		6		6		
29. Drawing Reference List		6		6		
30. Recommended Spare Parts List with Prices						
31. Speed-Torque and Time Curves						
32.						
33.						
34.						
35.						



SPECIFICATION 37-1608

ELECTRICAL WELL CONTROL PANEL SPECIFICATION

CLIENT: SHELL OIL COMPANY

PROJECT: ROCKY MOUNTAIN ARSENAL REMEDIATION PROJECT

INTERIM RESPONSE ACTION FINAL DETAILED DESIGN

RAIL CLASSIFICATION YARD/MOTOR POOL AREA IRA

LOCATION: ROCKY MOUNTAIN ARSENAL, COMMERCE CITY, CO



<u>CONTENTS</u>	<u>PAGE</u>
1. SCOPE	3
2. CODES AND ORDINANCES	3
3. GENERAL	3
4. EQUIPMENT FURNISHED	4
5. DESIGN	5
6. PANEL FINISH AND PAINTING (Interior and Exterior)	5
7. PANEL CONTROLS	5
8. ELECTRICAL	5
9. WIRING	6
10. DISCREPANCIES	6
11. TESTING	6
12. CRATING AND SHIPPING	6
13. GUARANTEE	6
14. SPECIAL INSTRUCTIONS	7
15. DELIVERY	7



SPECIFICATION 37-1608

ELECTRICAL WELL CONTROL PANEL SPECIFICATION

1. SCOPE

This specification covers the design, materials, fabrication and testing of the control panel and the mounting and wiring of the electrical components associated with the control panel.

2. CODES AND ORDINANCES

A. All design shall be in accordance with and shall conform to all requirements of the regulations of codes and ordinances applicable at the project location. If the local codes and ordinances conflict with these design criteria, the codes are to govern except in cases where these design criteria exceed them in quality or quantity of materials.

B. Regulatory agencies or standards having jurisdiction include, but are not limited to the following:

- 1) National Electrical Manufacturer's Association (NEMA)
- 2) Instrument Society of America (ISA).
- 3) American National Standards Institute (ANSI).
- 4) Joint Industrial Council (JIC).
- 5) Occupational Safety and Health Administration (OSHA).
- 6) National Electric Code (NEC).
- 7) Underwriters' Laboratory (UL).
- 8) American Society for Testing and Materials (ASTM).

3. GENERAL

A. The equipment furnished shall be, as far as practicable, the standard products of the manufacturer. Where two or more units of the same type or class of equipment are required, these units shall be the product of one manufacturer and the units shall be interchangeable.



- B. Instrumentation and materials specified herein shall be considered as minimum quantity acceptable. Substitutions of instrumentation and materials of higher quality or longer service life may be made only with prior approval by Morrison Knudsen.
- C. Control panel assembly shall be complete with mounting and wiring of all controls associated with the panel. All hook-ups shall be tested and the complete panel assembly as delivered shall be ready for installation in the field as an operating unit without further panel work other than receiving field connections, all field work shall be completed by Contractor.
- D. Panel fabricator shall furnish and be held responsible for all materials, labor and other services for engineering, designing and fabricating the panels and panel assembly in accordance with this Specification and as shown on the panel drawings furnished. Panel fabricator shall be responsible for the functional operation of all equipment and material which he supplies.
- E. Panel fabricator shall provide and install all wiring, wire ducts, terminals, etc., and shall install all wiring from the controls to the panel terminals in accordance with associated specifications. Signal wiring and control wires shall be run in separate ducts.
- F. Panel fabricator shall be responsible for all mounting cutouts, in accordance with dimensions and tolerances specified by the various manufacturers.

4. EQUIPMENT FURNISHED

- A. Panel fabricator shall furnish, mount, and wire the following items:
 - 1) Circuit breakers
 - 2) Terminal blocks and mounting hardware
 - 3) Wire duct with covers
 - 4) Pushbuttons
 - 5) Nameplates and tags
 - 6) Pilot lights



- 7) Selector switches
- 8) Wire
- 9) Relays and sockets with mounting hardware
- 10) Any items other than above that the panel fabricator shall supply, mount and wire will be identified on panel layout drawings.

5. DESIGN

Electrical well control panel shall be Hoffman (or equal) type enclosure with back subpanel.

6. PANEL FINISH AND PAINTING (Interior and Exterior)

Electrical well control panel shall be painted ANSI 61 light gray outside and white inside.

7. PANEL CONTROLS

Cutouts shall be located such that the bottoms of instrument bezels form a straight horizontal line. Cutout edges shall be smooth and square.

8. ELECTRICAL

- A. All components and wiring must conform with the requirements of the codes and local authorities. Ratings, construction and testing shall be in accordance with the applicable standards of NEMA. All devices must be approved by UL except those categories for which no approval list has been established.
- B. All terminal strips shall be located at rear of the panel. The terminal must be clearly identified. Panel fabricator shall provide Buchanan 600 volt type terminals, Catalogue No. P0724 for ac power and control wiring. Maximum number of wires per terminal shall be two (2). Interconnecting wires shall be identified with wire number at both ends with heat shrink markers.
- C. Wiring ducts with open slots on the side for fast cable take-off, and snap-on cover, shall be used where possible by the panel fabricator for all wiring within the panel. Wiring that cannot be incorporated shall be wrapped with spiral wrapping or equal.



9. WIRING

- A. Panel fabricator shall provide all alarm wiring between annunciators and the terminal strips.
- B. Panel fabricator shall provide all 120 volt ac motor control wiring between board mounted hand switches, pushbuttons, lights, and terminal strips.
- C. All control wiring shall be 14 AWG minimum with 600 volt insulated copper single conductor, 19 strand, type MTW.

10. DISCREPANCIES

In the event of conflict between this specification and attached drawings the Engineer shall be consulted and conflicts resolved before any work is performed.

11. TESTING

- A. The complete control panel shall be given the following tests:
 - 1) Insulation resistance shall be measured from line-to-line and from line-to-ground and should not be less than 10 megohm.
 - 2) Wire identification to components and terminal blocks shall be verified with continuity checks.
- B. The entire panel shall be given a shop final checkout test prior to shipment. Test shall serve to functionally check operation of all control circuits, and alarms, using simulation instruments supplied by the panel fabricator for this purpose.

12. CRATING AND SHIPPING

- A. Panels shall be packed and crated in such a manner as to protect panels from damage during shipment.
- B. The fabricator shall provide for insurance of all control panels and components, coverage to be effective until the panel is accepted by Morrison Knudsen.

13. GUARANTEE

- A. All panels and equipment furnished by panel fabricator shall be guaranteed against defective material, poor workmanship, poor finish or failure in normal usage for



a period of one (1) year from date of installation or regular operation.

- B. Panel fabricator shall also guarantee that all panels and equipment will not deteriorate unduly during shipment or prior to being placed in regular operation, provided reasonable care is exercised by the Purchaser.

14. SPECIAL INSTRUCTIONS

- A. Panel fabricator shall include in the quotation, time required to furnish the following:
- 1) Drawings showing principal dimensions of installed equipment and components.
 - 2) Control panel internal wiring diagrams showing all components and terminal blocks.
 - 3) For manufacturer of this equipment complete and ready for shipment, based on complete receipt of design information at the factory.
- B. Any deviations, exceptions or options selected from this specification are to be indicated.
- C. Bill of material, material schedule, layout sketches, and descriptive brochures or bulletins of all components and (or) equipment to be supplied to meet this specification. This includes relays, switches, etc.

15. DELIVERY

Bidder shall state minimum time for manufacturer and delivery from receipt of order.



SPECIFICATION SECTION 37-1651

13.8 kV POLE LINE

CLIENT: SHELL OIL COMPANY

PROJECT: ROCKY MOUNTAIN ARSENAL REMEDIATION PROJECT

INTERIM RESPONSE ACTION FINAL DETAILED DESIGN

RAIL CLASSIFICATION YARD/MOTOR POOL AREA

LOCATION: ROCKY MOUNTAIN ARSENAL, COMMERCE CITY, CO



<u>CONTENTS</u>	<u>PAGE</u>
1. SCOPE	3
2. RELATED WORK	3
3. REFERENCE STANDARDS	3
4. REFERENCE DRAWINGS	4
5. AMBIENT CONDITIONS	4
6. EQUIPMENT BIDS	4
7. GENERAL REQUIREMENTS	5
8. MATERIALS AND CONSTRUCTION	5
9. STRUCTURE ASSEMBLY DETAILS	15

APPENDIX A - STRUCTURE ASSEMBLY DETAILS



SPECIFICATION 37-1651

13.8 kV POLE LINE

1. SCOPE

- A. This specification, Specification 36-0102, "GENERAL SPECIFICATIONS FOR EQUIPMENT", the Project Drawings, and other Contract Documents cover the general design, construction and operating requirements for the 13.8-kV pole line.
- B. The term "Engineer", as used in this specification, shall mean Owner or his designated representative.

2. RELATED WORK

- A. The following items of related work are covered in other specification sections but are not included in the scope of furnishing the equipment described herein.
 - 1) Electrical Work (Specification 37-1601).

3. REFERENCE STANDARDS

- A. The equipment shall be designed, manufactured and tested in accordance with the applicable requirements of the latest edition of the following codes, standards and references:
 - 1) ANSI - American National Standards Institute
 - 2) NEMA - National Electrical Manufacturers Association
 - 3) AWS - American Welding Society
 - 4) IEEE - The Institute of Electrical and Electronics Engineers, Inc.
 - 5) NEC - National Electrical Code
 - 6) State of Colorado Standards and Codes
 - 7) MSHA - Mine Safety and Health Administration
 - 8) ASA - American Standards Association



- 9) AWPA - American Wood Preservers Association
- 10) REA - Rural Electrification Administration
- 11) NESC - National Electrical Safety Code
- 12) ASTM - American Society for Testing and Materials

4. REFERENCE DRAWINGS

A. The following list of drawings are intended to indicate the general arrangement of the pole line and its associated details.

- 1) Drawing Numbers: 37804-37-006A & 006B

5. AMBIENT CONDITIONS

A. The equipment specified herein shall be designed and constructed to operate successfully at the rated values under the following conditions:

- 1) Location: Outdoors
- 2) Elevation: 5,215 feet MSL
- 3) Temperature Range: -30°F to 120°F
- 4) Seismic Zone: 3
- 5) Wind Velocity: 110 mi/h
- 6) Ice Loading: 1 inch radial
- 7) Frost Level: 5 ft (depth)
- 8) Isokeraunic Level: 30 days/year
- 9) NESC Loading Classification: Heavy

6. EQUIPMENT BIDS

A. In addition to requirements of the paragraph, "Bid Submission" in Specification 36-0102, "GENERAL SPECIFICATIONS FOR EQUIPMENT", the following information shall be furnished with the bid:

- 1) If there is any deviation in arrangement and dimension of the pole line from the information given on the reference drawings indicated in



Paragraph 4, herein, a preliminary sketch shall be provided showing the changes, including the location and mounting of the equipment.

7. GENERAL REQUIREMENTS

- A. All construction work shall be done in a neat and workmanlike manner in accordance with specification, construction drawings and best modern practice. The overhead pole line installation shall conform to the requirements of ANSI C2, "National Electrical Safety Code", "Manual of Accident Prevention in Construction" by the Associated General Contractors of America, Inc. and MSHA.

8. MATERIALS AND CONSTRUCTION

A. Poles:

- 1) The poles shall be cut from live timber; shall be 45 ft., Class 4, Douglas fir; and shall be of the class and length shown on the drawings. The poles shall conform to the following specifications:
 - a) The poles shall conform to "American Standard Specifications and Dimensions for Wood Poles 05.1", as approved by the American Standards Association.
 - b) Poles shall be conditioned before treatment by air seasoning to 20% maximum average moisture content in such a manner as will not cause injurious checking, splitting, or warping during the seasoning and treating process.
 - c) Poles shall be full length pressure treated with two applications of pentachlorophenol petroleum according to AWPA Standard C.4. Poles shall be galled, bored and roofed prior to treatment.
 - d) In handling poles, care shall be taken to prevent injury to the treated portions of the poles. Pole tongs, cant hooks, and other pointed tools liable to produce a penetration of more than 1" shall not be used. Pole tongs shall be handled so as to avoid tearing away of material. Treated poles shall not be dragged along the ground and shall not be



allowed to lie in contact with the ground for more than 20 days.

- e) Poles shall be branded by the Manufacturer with his mark and date of treatment, height and class of pole, wood species, preservation code and retention.
- f) Poles in the same structure shall be selected so as to have approximately the same top dimension. Poles having larger top diameters than average shall be sorted for use in angle and dead end structures.
- g) Bolt and pilot holes shall be drilled in accordance with standards and crossarm drilling guides. All unused holes in the poles shall be plugged with tight fitting treated cedar plugs. Cedar plugs shall be treated by dipping in the preservative that corresponds with the original treatment of the pole.

B. Pole Setting:

- 1) Depth of the setting shall be measured on the low side of the hole. All poles shall be set to within three (3) inches of the required depth setting which shall be as follows:

<u>Pole Length (feet)</u>	<u>Setting in Soil (feet)</u>	<u>Setting in All Solid Rock (feet)</u>
35	6.0	5.0
40	6.0	5.0
45	6.5	5.5
50	7.0	6.0
55	7.5	6.5
60	8.0	7.0
65	8.5	7.5
70	9.0	8.0
75	9.5	8.5
80	10.0	9.0
85	10.5	9.5
90	11.0	10.0
95	11.0	10.0
100	11.0	10.0



- 2) "Setting in Soil" depth shall apply:
 - a) Where poles are to be set in soil:
 - b) Where there is a layer of soil more than two feet in depth over solid rock.
 - c) Where the hole in solid rock is not substantially vertical or the diameter of the hole at the surface of the rock exceeds approximately twice the diameter of the pole at the same level.
- 3) "Setting in All Solid Rock" depth shall apply:
 - a) Where poles are to be set in solid rock and where the hole is substantially vertical, approximately uniform in diameter and large enough to permit the use of tamping bars the full depth of the hole.
 - b) Where there is a layer of soil two (2) feet or less in depth over solid rock, the depth of the hole shall be the depth of the soil in addition to the depth specified under "Setting in All Solid Rock" provided, however, that such depth shall not exceed the depth specified under "Setting in Soil."
- 4) For a multi-pole structure on a sloping ground, setting depth shall be increased as required to the level of the crossarm.
- 5) Poles shall be set in alignment and plumb except at corners, terminals, angles, junctions, or other points of strain, where they shall be set and raked against the strain so that the conductors shall be in line. All poles shall be plumb after conductors are strung.
- 6) Poles shall be raked against the conductor strain not less than one inch for each ten feet of pole length nor more than two inches for each ten feet of pole length after conductors are installed at the required tension.
- 7) Pole backfill shall be mixed with coarse crushed gravel and must be thoroughly tamped the full depth. Excess dirt must be banked around the pole. Frozen earth, wood, leaves, decaying matter, or any



material subject to decay shall not be used in backfilling.

C. Hardware: All pole line hardware shall be hot-dipped, galvanized in conformance with ASTM A153.

D. Guys and Anchors:

- 1) Guy wire shall be galvanized, 7-strand, 3/8 inch, extra-high strength, and shall have Class A steel strand in accordance with ASTM A 363.
- 2) Guys shall be installed before the conductors or overhead ground wires are strung and shall be attached to the pole as shown on the project drawings.
- 3) Anchors shall be power screw type, with single 10" diameter helix and 3/4" galvanized steel rod. Crossplate type anchors are also acceptable and must be corrosion resistant and backfill thoroughly tamped.
- 4) All anchors and rods shall be in line with the strand and shall be so installed that approximately 8 inches of the rod remain out of the ground. As deemed necessary, the projection of the anchor rod above earth may be increased to a maximum of 12 inches to prevent burial of the rod eye.
- 5) Guy guards shall be provided where guys are exposed to pedestrian or vehicular traffic and shall be made of yellow plastic.

E. Conductors:

- 1a) The span conductors shall be AWG #3/0 aluminum conductor steel reinforced (ACSR) and shall conform to the requirements of ASTM Designation B232, and the following specifications:
 - a) Main pole line - #3/0 AWG ACSR, 6/1 aluminum/steel stranding.
 - b) Each individual aluminum wire entering into the construction of the completed conductor shall conform to ASTM Designation B230. The core wire shall be galvanized steel wire conforming to ASTM Designation B245.



- 1b) Pole device wiring shall be #2/0 AWG stranded copper wire with sunlight exposure rated insulation providing raptor protection.
- 1c) Conductors feeding the 500 KVA transformer from the pole #15 cutouts shall be 15 KV rated, 133% shielded single conductor, type MV-90, direct burial rated.
- 2) Conductors shall be handled with care. Conductors or overhead ground wires shall not be tramped on nor run over by vehicles. Each reel shall be examined and the wire shall be inspected for cuts, kinks, or injuries. Injured portions shall be cut out and the conductor spliced. The conductors shall be pulled over suitable rollers or stringing blocks properly mounted on pole, if necessary, to prevent binding while stringing.
- 3) All conductors shall be cleaned thoroughly by wirebrushing before splicing or the installation of a connector or clamp. A suitable inhibitor shall be used before splicing or applying connectors over aluminum conductor.

F. Handling and Stringing of Conductor:

- 1) Handling, stringing, sagging and clipping-in of conductor shall be by methods which will prevent damage to conductor and line structures in any way. Bends of less than 5-inches radius will not be permitted.
- 2) Stringing sheaves may be hung on insulators or in straps of equal length attached to structure with suitable hooks or clamps placed so as to properly distribute load. Grips must be smooth type designed for use with ACSR cable.
- 3) Any part of structure subject to abrasion by pulling line shall be protected against damage by suitable lagging. Sock line for each conductor shall be of sufficient length to avoid overloading structures and damaging conductor. When more than one conductor is strung with a running board, sock lines shall be used and shall be of such length that conductors will not be dragged transversely over ground or lagging. Sock line shall be connected to conductor with a swivel connection and a stock-type grip. Tail wires of grip shall be taped down so



that grip will run freely in sheaves and will not damage sheaves. Sheaves shall be protected from damage caused by steel pulling lines at high tension. Sheaves damaged by pulling lines shall not be used on conductor. Sheaves shall be lined or otherwise designed to prevent damage to the ACSR cable.

- 4) Unless otherwise noted tension stringing, use of lagging or a combination of both may be used to prevent damage. When tension is used to clear obstructions, tension shall not be permitted to exceed sagging tension prescribed for portion of line involved. Lagging shall consist of any non-metallic material which will not damage conductor. It shall be of sufficient length and weight that it will not be displaced by motion of conductor, provided that it shall not be less than eight feet long and 1-1/2 inches thick. It shall be free of any insoluble material, such as pitch, which can be transferred to conductor. Adequate guards shall be provided where there may be danger of conductor being run over by vehicles or damaged by other equipment and objects. Conductor shall not be left in contact with ground, lagging, vegetable matter or any conducting or semi-conducting material longer than five calendar days. Conductors shall not be allowed to hang in stringing blocks more than 18 hours before being pulled to specific sag. After being sagged, conductors shall hang in stringing blocks for not less than two hours, nor more than 18 hours before being tied in.

G. Sagging Conductors:

- 1) Conductors shall be sagged by the Contractor in accordance with the initial sag charts furnished by the conductor vendor. Each conductor shall be sagged individually for temperature at the time of sagging. All conductors in a sag section shall be treated uniformly with respect to tension and time intervals during stringing, prestressing and sagging. Sagging operations shall not be carried on when wind or other physical conditions prevent satisfactory sagging.
- 2) The length of conductor sagged in one operation shall be limited to that length which will permit attainment of correct sag. Anchoring of snubs will



not be permitted to any structure except dead-end structures at the normal point of attachment.

- 3) Spans used for determining the correct sag on pre-sag, shall be, where possible, longer level spans in section of line being sagged. Sag shall be determined on both sides of angle points of more than ten degrees. When sagging conductor lengths covering more than four spans, sag shall be determined at or near each end but not less frequently than at one mile intervals. In unusual situations, additional determinations may be required. After the conductors in spans used for determination of correct sag have been pulled to correct tension, as many successive spans as can be observed from instrument positions shall be examined for uniformity of sag. Determination of sag shall be by means of transit or other suitable instruments furnished by contractor at no extra cost to Owner. The return wave method of sagging shall not be used.
- 4) The conductors shall be sagged within tolerance of 0.01 times sag in feet but not exceeding 0.5-foot, providing all conductors in sagging span assume the same relative position to true sag.
- 5) All conductors shall be plumb-marked at each structure for complete section sagged before clipping in or dead-ending of conductor is begun. On H-frame wood pole structures, conductor shall be plumb-marked in line with centers of poles at the ground line. On single pole structures, line of sight shall be over center of pole at ground line and parallel to the line post insulator. Conductor shall be marked with paint, crayon, or wax pencil - not with metal objects.
- 6) Insulator strings on three adjacent structures to new section to be sagged shall be clipped to the conductor. These insulator strings shall be in plumb position upon completion of sagging of the new section and during plumb-marking.
- 7) All conductors in a sag section shall be sagged, plumb-marked (if required), and clipped in during one continuous seventy-two (72) hour period.
- 8) The sag of all conductors after stringing shall be in accordance with the conductor Manufacturers' recommendations.



H. Jumpers:

- 1) Contractor shall make up and install all jumpers included on dead-end structures, substation structures and terminal structures. Jumpers shall be so proportioned and hung that under normal conditions, they will meet clearance requirements of National Electrical Safety Code.
- 2) Conductor jumpers shall be continuous, where practicable. Where it is not practicable to install continuous jumpers, non-tension compression connectors shall be installed. Only one compression connector per jumper shall be installed. Jumpers shall be formed to provide maximum amount of clearance and in accordance with project drawings.
- 3) To meet raptor protection guidelines, jumper conductors shall be insulated and rated for sunlight exposure.
- 4) When clevis bolt on dead-end assembly will not be horizontal, bolt shall be installed with head up.
- 5) Line termination at substations - the Contractor shall leave adequate conductor lengths at substation at reach terminal pads on switch structures.

I. Conductor Splices and Dead-Ends:

- 1) Splices shall not be installed in crossings, over roads, highways, or other power lines. Dead-ends shall not be installed within 100 feet of a splice sleeve or a compression repair sleeve.

Splices shall not be made within 15 feet of a structure nor shall there be more than one splice per conductor. Whenever splices or dead-ends are made under tension, come-along shall not be placed nearer than 25 feet to the point of splice or dead-end. The conductor shall be laid out straight for a distance of 50 feet and straightened at ends before preparation of ends for splicing or dead-ending. Lay of strands shall be tightened before first compression is made. Aluminum strands shall be cut back a distance that will leave not more than 1/8-inch between ends of strands and compressed steel sleeve. If this distance is greater than 1/8-inch, it shall be filled with aluminum strand or flat aluminum armor wire. Ends of conductor and



bores of compression sleeves shall be thoroughly cleaned immediately prior to compressing. Compression shall be carefully made so that completed splice or dead-end is as straight as possible. If completed splice or dead-end requires straightening, it shall be straightened on a wood block by use of a sledge and shaper or wood maul. However, if steel sleeve is bent too much to slip inside aluminum sleeve, it shall be straightened by constantly applied pressure or replaced. Steel sleeve shall not be straightened by pounding with any type of hammer or maul.

- 2) All splices shall be installed in accordance with the procedure as recommended by the Manufacturer. All splicing tools and equipment required in splicing shall be furnished by the Contractor. Before stringing operations begin, the Contractor shall submit to the Engineer a list of types, brands, and catalog number of the hydraulic press, dies, wrenches, etc., that the Contractor intends to use for splicing the conductor and overhead shield wire. All splicing tools and equipment must be approved in writing by the Engineer. Failure to secure this approval shall be a cause for the suspension of the stringing operations until approval is obtained.

J. Conductor Repairs:

- 1) Damage caused by Contractor shall be repaired at the expense of the Contractor. Any deformity on the surface of the conductor which can be detected by eye or by feel shall be considered a damage. Damage includes, but is not limited to, nicks, scratches, abrasions, kinks, basketing, popped out strands, and broken strands.
- 2) Depending upon severity of the damage and length of the damaged section, repair shall be made by carefully smoothing with fine sandpaper covering with a repair sleeve, or preformed repair rods, or by cutting and splicing.
- 3) Kinked, basketed or severely damaged sections of conductor shall be cut out.
- 4) When one aluminum strand is broken or nicked deeper than one-third its diameter, or when a number of strands are reduced in area by less than the area



of one strand, a repair sleeve or preformed repair rods shall be installed. When more than one strand is broken or conductor is reduced in area by more than one strand, the damaged section shall be cut out.

- 5) Where there is repeated damage in the same span or inconsecutive spans, all conductors in these spans shall be replaced.
- 6) All damage caused by come-along and other gripping devices shall be repaired or cut out before conductor is finally sagged.
- 7) Where the damage normally repairable by a repair sleeve or pre-formed repair rod occurs under at least 12 inches from the end of armor rods, repair sleeve or repair rods shall be omitted.
- 8) Not more than two repair sleeves, splice sleeves or sets of preformed repair rods for repairing damage shall be applied in every 200 feet of conductor. Compression repair sleeves shall not be installed within 50 feet and splice sleeves shall not be installed within 100 feet of any other compression fitting. Compression repair sleeves shall not be installed within 15 feet of a suspension structure. Preformed repair rods shall not be installed within 15 feet of any structure.

K. Insulators:

- 1) Insulators shall be wet process porcelain type, radio interference free and shall conform to ANSI standards as follows:
 - a) Vertical clamptop line post insulators shall conform to ANSI Standard and the following:

Nominal Voltage Rating	-	15 kV
Flashover - Dry	-	60 kV
- Wet	-	45 kV
Impulse Flashover - Positive	-	130 kV
- Negative	-	155 kV
Cantilever Strength	-	2800 lb



- b) Suspension insulators shall be ANSI class 52.4 per ANSI C29.2.
- c) Guy strain simulators shall be ANSI Class 54.4 per ANSI C29.4.
- 2) All insulators shall be thoroughly cleaned just before installation.
- 3) Care shall be exercised in handling and erecting insulators and in assembling suspension units to insure that all cotter keys are fully inserted in the insulated caps.
- 4) Deadend insulators may be epoxy type, 15KV rated.

9. STRUCTURE ASSEMBLY DETAILS

See Drawings #37804-37-006A & 006B.



APPENDIX A

STRUCTURE ASSEMBLY DETAILS

<u>Sheet</u>	<u>Title</u>
1651-1	Three Phase Transformer Installation
1651-2	Secondary Terminal Pole 3 Phase
1651-3	Transformer Connections Delta-Wye
1651-4	Single Phase Transformer Installation
1651-5	Secondary Terminal Pole 1Ø or 3Ø Service
1651-6	Raptor Protection Installation of Transformer
1651-7	Raptor Protection Nonconductive Crossarm Braces
1651-8	Raptor Protection 3Ø Corner Configuration
1651-9	Raptor Protection Transformer Configurations
1651-10	Crossarm Construction 2° to 5° Angle
1651-11	Distribution Guy Anchor Detail
1651-12	Steel Plate Anchor Assembly
1651-13	Distribution Guy and Anchor Detail
1651-14	Distribution Guy and Anchor Detail
1651-15	Distribution Wye - Delta Connections
1651-16	Distribution Crossarm and Bracing
1651-17	Distribution Pole Detail
1651-18	Skipped
1651-19	Three Transformer Cluster Mounted
1651-20	Distribution Pole and Guy Detail
1651-21	Distribution Pole and Guy Detail



1651-22	15 KV Cable Termination
1651-23	15 KV Lug Connection
1651-24	15 KV Cable Connection

MATERIAL LIST

Item No.	Qty	Item	Size Req'd
1	3	Transformer	
2	3	Connector	Ground
3	10'	Conductor	#4 Copper, Solid
4	15'	Conductor	#4 Copper, 600V Insul
5	2	Connector	Compression, Copper
6	2	Connector	Compression, Copper
7	3	Cutout	Fused, 100A Max.
8	3	Arrester	Surge
9	6	Bracket	Mounting
10	18'	Conductor	#4 Copper, Solid
11	3	Connector	Stirrup, Hot Line
12	2	Connector	Hot Line Clamp
13	2	Crossarm	5ft 7in
14	2	Galn.	Crossarm
15	3	Bolt	Double Arming, 5/8in x 20in
16	4	Washer	Square, Flat, 5/8in
17	4	Washer	Spring, RFI
18	2	Bolt	Machine, 3/8in x 5in
19	2	Washer	Round Flat, 3/8in
20	2	Washer	Spring, RFI
21	2	Drace	Crossarm, Wood
22	1	Leg	Screw, 1/2in x 4in
23	1	Pin	Stand-off, Fiberglass
24	1	Bolt	Machine, 5/8in x 12in
25	4	Insulator	Pin Type
26	12'	Conductor	#6 Copper, Solid
27	1	Connector	Compression, Copper
28	1	Connector	Compression, Copper
29	2	Bolt	Machine, 5/8in x 12in
30	2	Washer	Square, Flat, 5/8in
31	2	Washer	Spring Radio Influence, 5/8in
32	1	Bracket	Cluster, Transformer
33	1	Rod	Ground, Copper Covered, 8 Ft
34	1	Connector	Ground Rod, Bronze
35	1	Connector	Compression, Copper
36	3	Pin	Steel, 1 Inch Thread

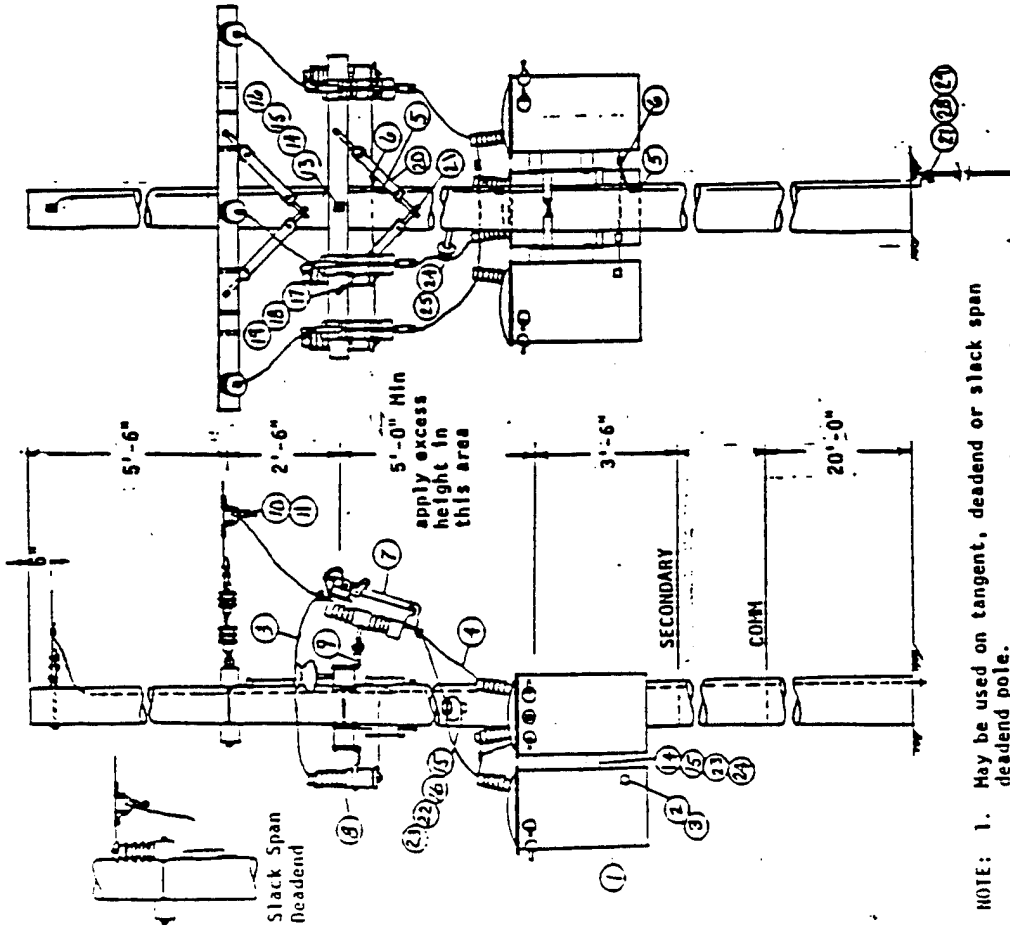

NOTE: 1. May be used on tangent, deadend or slack span deadend pole.
 2. Tie overhead neutral shield wire, arrester ground, transformer case, secondary messenger and ground wire together.



MORRISON KNUDSEN CORPORATION
 ENVIRONMENTAL SERVICES GROUP

THREE PHASE TRANSFORMER
 INSTALLATION

DRAWN BY	APPROVED BY	CONTRACT NUMBER
CHECKED BY	SCALE	SHEET NUMBER
	NONE	1651-1

MATERIAL LIST

Item No.	Quantity		Item
	Conv.	CSP	
1	1	1	Transformer, Type and Size Req'd
2	As Req'd	As Req'd	Conductor, #4 Copper Solid
3	As Req'd	As Req'd	Conductor, #4 Copper, Str. 600V Insul
4	2	2	Bolt, Machine, 5/8in x 12in
5	2	2	Washer, Square, 5/8in
6	2	2	Washer, Spring, RFI
7	2	1	Connector, Copper,
8	1	1	Connector, Ground, Transformer
9	1	1	Connector, Stirrup, Hot Line
10	1	1	Connector, Hot Line Clamp
11	1	0	Cutout, Fused, 100A Max.
12	1	0	Arrester, Surge
13	1	1	Rod, Ground
14	1	1	Connector, Ground Rod

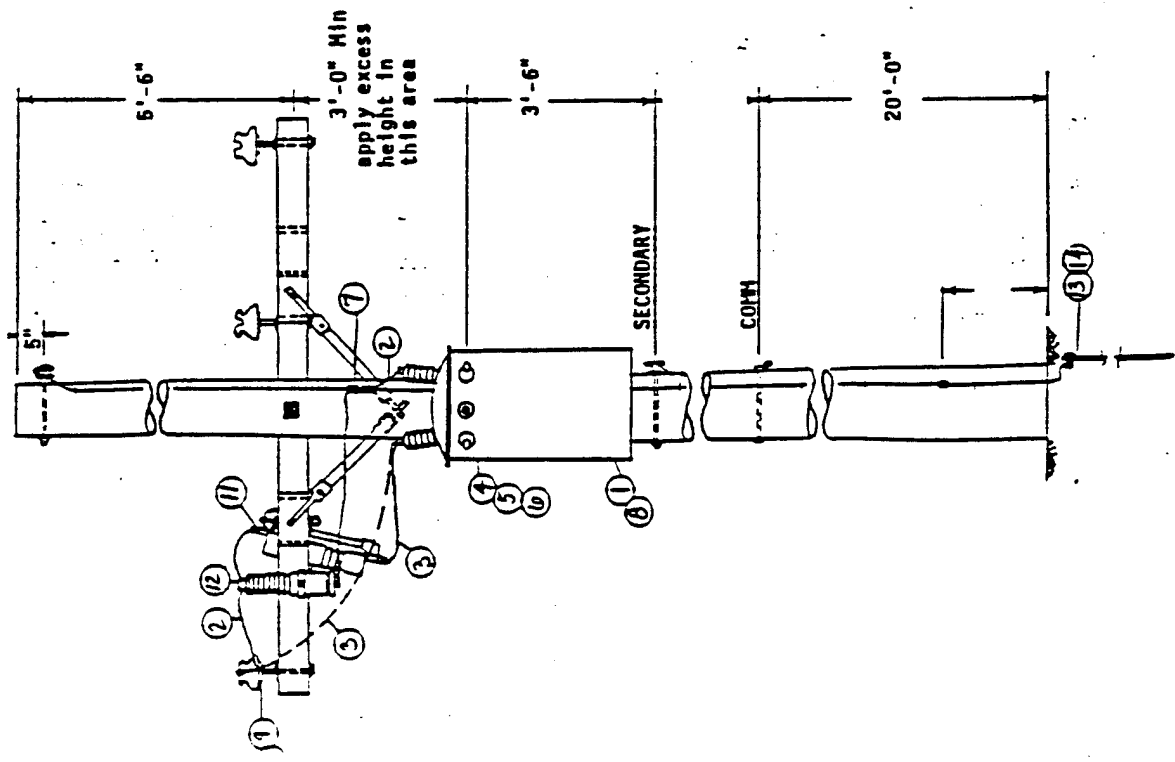

- NOTE: 1. On CSP transformer installations, omit the cutout and arrester. Dotted line shows route for CSP transformer riser.
2. Tie overhead shield wire neutral, secondary neutral, ground wire, and transformer ground together.



MORRISON KNUDSEN CORPORATION
ENVIRONMENTAL SERVICES GROUP

SINGLE PHASE
TRANSFORMER INSTALLATION

DRAWN BY APPROVED BY CONTRACT NUMBER

CHECKED BY SCALE NONE SHEET NUMBER 1651-4

Item No.	Qty	Item
1	1	Elbow, 90°, Rigid Long Radius
2	4	Screw, Lag
3	2	Strap, Duct, Steel, 1 Hole
4	As Req'd	Duct, Steel, IMC
5	1	Connector, Ground, Copper Cable to Pipe
6	As Req'd	Conductor, #4 AWG Solid Copper, Soft Drawn
7	4	Connector, Compression
8	1	Cap, Entrance, Threadless Type
9	2	Connector, Two-bolt, Insulated, Alum
10*	4	Connector, Sleeve, Compression, Alum
11	1	Connector, Two-bolt, Alum
12	1	Connector, Compression, Alum

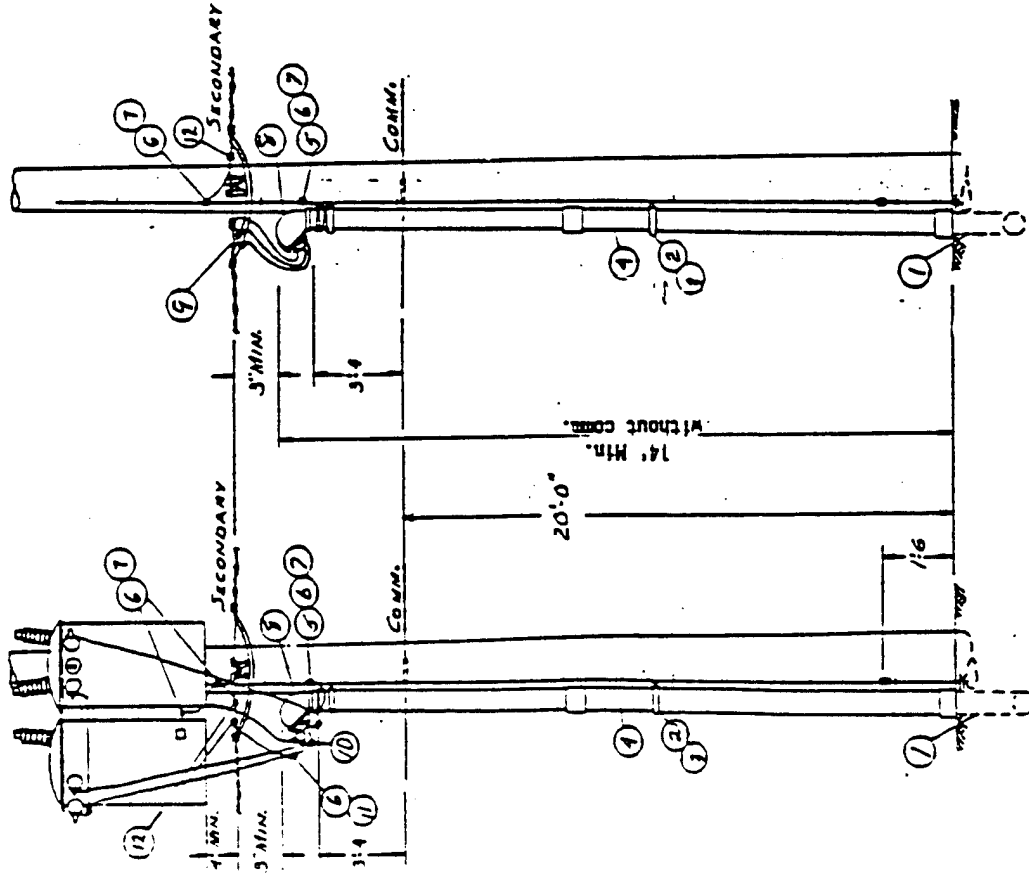

 MORRISON KNUDSEN CORPORATION ENVIRONMENTAL SERVICES GROUP		SECONDARY TERMINAL POLE 1φ OR 3φ SERVICE CONNECTED TO TRANSFORMER FULL DUCT SERVICE	
		DRAWN BY APPROVED BY	CONTRACT NUMBER

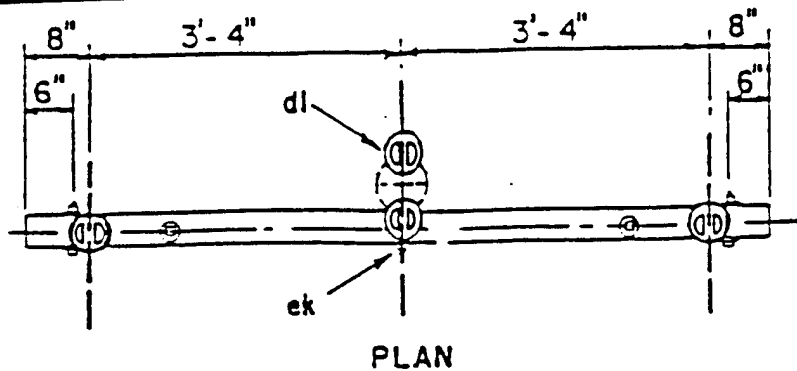

PLAN

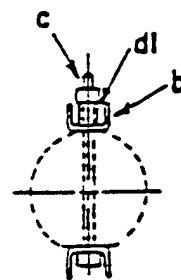

POLE TOP PIN ASSEMBLY

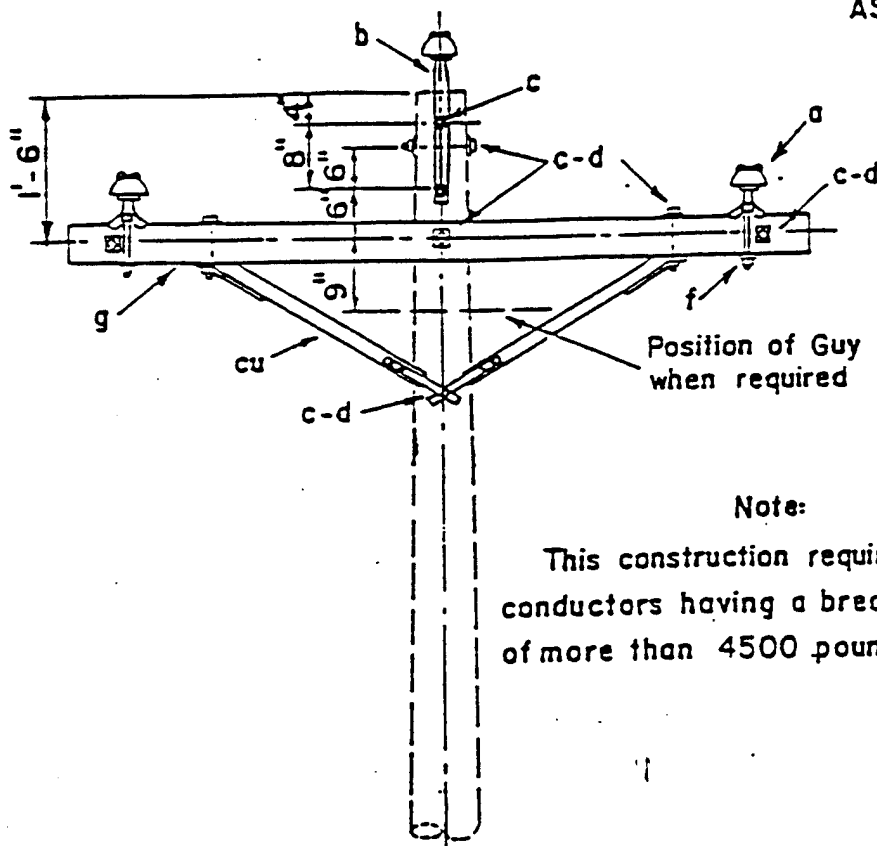

Note:

This construction required for all conductors having a breaking strength of more than 4500 pounds.

MORRISON KNUDSEN CORPORATION
ENVIRONMENTAL SERVICES GROUP



CROSSARM CONSTRUCTION
2' TO 5' ANGLE

DRAWN BY	APPROVED BY	CONTRACT NUMBER
CHECKED BY	SCALE	SHEET NUMBER
	NONE	1651-10

ITEM	NO	MATERIAL	ITEM	NO	MATERIAL
a	4	Insulator, pin type	g	1	Crossarm, 3 3/4" x 4 3/4" x 8'-0"
b	2	Pin, pole top, 20"	cu	1	Brace wood, 60" span
c	8	Bolt, machine, 3/8" x req'd length			
c	2	Bolt, machine, 1/2" x req'd length	dl	2	Pipe spacer, 3/4" dia. x 1 1/2"
d	10	Washer, 2 1/4 x 2 1/4 x 3/8, 1 1/8 hole	ek		Locknuts
d	2	Washer, rd., 1 1/8" diam, 3/8" hole			
e	2	Pin, crossarm, clamp type			

HOLE MAY BE BORED OR DUG

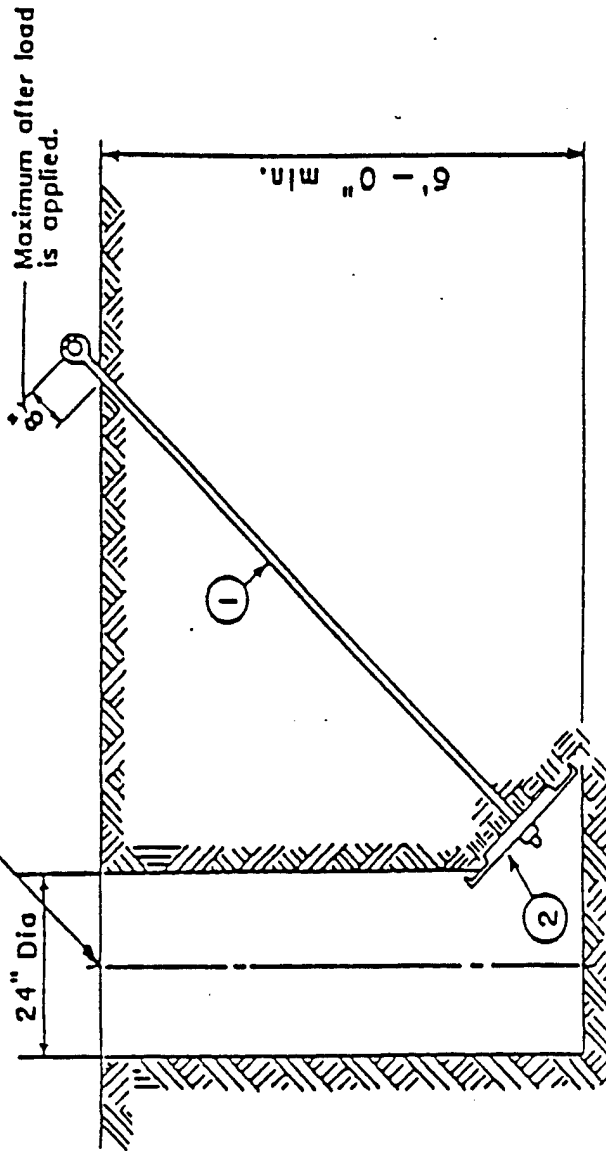

QTY	DESCRIPTION	ITEM	MAXIMUM WORKING LOADS
1	3/4" x 8'-0" Twin Eye Anchor Rod & Sq. Nut	x	10000 lb
2	Plate Anchor	z	10000 lb in average soil



MORRISON KNUDSEN CORPORATION
ENVIRONMENTAL SERVICES GROUP

STEEL PLATE
ANCHOR ASSEMBLY

DRAWN BY	APPROVED BY	CONTRACT NUMBER
CHECKED BY	SCALE	SHEET NUMBER
	NONE	1651-12

THREE-PHASE UNDERGROUND TERMINAL
ON CROSSARM DEADEND POLE
FOR LOADS UP TO 200 AMPS
13.2Y/7.62 kV or 24.9Y/14.4 kV

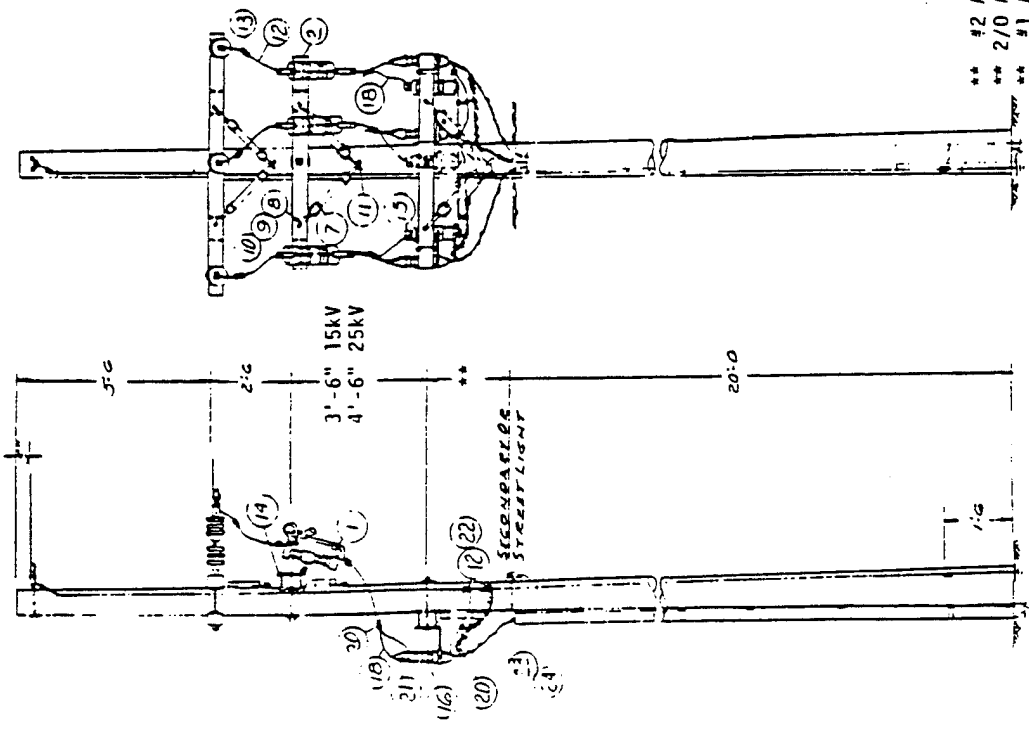

MATERIAL LIST

Item No.	Qty	Item
1	3	Cutout, Open Fuse
2	2	Crossarm, 5ft. - 7in., 4 Pin
3	2	Galv. Crossarm
4	2	Bolt, Machine, 5/8in x 10in
5	4	Washer, Square, Flat 5/8in
6	2	Washer, Anti-Static, 5/8in
7	4	Brace, Crossarm, Hood
8	4	Bolt, Machine, 3/8in x 5in
9	4	Washer, Round Flat, 3/8in
10	4	Washer, Anti-Static, 3/8in
11	2	Screw, Lag, 1/2in x 4in
12	18'	Conductor, #4 Solid Bare, Copper
13	3	Connector, Compression, Alum
14	3	Bracket, Arrestor & Cutout, N.E.M.A.
15	3	Surge Arrestors
16	3	Terminator, Outdoor, Underground
18	12'	Conductor, #4 Stranded Copper, 600V Insul
22	4	Connector, Compression, Copper
20	5	Connector, Compression, Copper
21	3	Cover, Wildlife, Protector
23	3	Bracket, Pole Mounting
24	3	Assembly, Back Strap

NOTE: #4 Sol. Copper S.D. from concentric neutral to static neutral. This wire shall be in addition to any existing pole ground.

- ** #2 Al 15KV 36" Min
- ** 2/0 Al 15KV 48" Min
- ** #1 Al 25KV 48" Min

** Apply excess height in this area

MORRISON KNUDSEN CORPORATION
ENVIRONMENTAL SERVICES GROUP

DISTRIBUTION GUY
AND ANCHOR DETAIL

CONTRACT NUMBER

SHEET NUMBER

1651-14

APPROVED BY

SCALE NONE

CHECKED BY

TRANSFORMER CONNECTIONS
WYE-DELTA

The wye-delta connection is used when 240 volt or 480 volt delta secondary is required. With the 240 volt secondary, 120/240 volt single phase loads may be served from the middle transformer. The bank may be connected open wye-open delta to maintain service should one transformer be disabled.

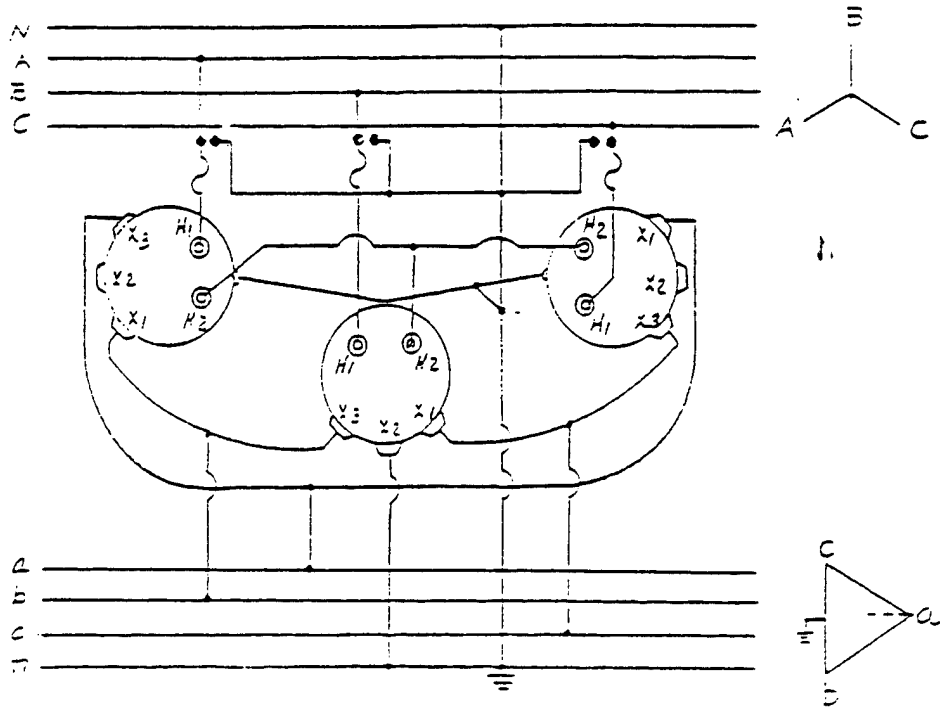

Caution:

DO NOT CONNECT THE BANK PRIMARY NEUTRAL TO THE SYSTEM NEUTRAL. If the primary side is grounded, the bank will act as a grounding bank and is susceptible to burn-out with unbalanced or faulted primary.

Omit the neutral conductor and midpoint connection on banks serving 3-Wire delta loads only. On such banks, of 480 volts or less, one of the secondary phase conductors shall be grounded.

SYMBOLS

Arrestor — ● —

Fused Cutout — ◡ —

DRAWN BY _____
CHECKED BY _____
APPROVED BY _____
SCALE _____
SHEET NUMBER 1651-15
CONTRACT NUMBER _____



MORRISON KNUDSEN CORPORATION
ENVIRONMENTAL SERVICES GROUP

DISTRIBUTION COPY
AND ANCHOR DETAIL

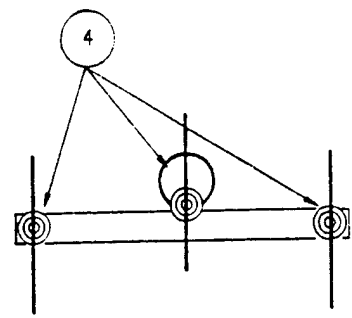
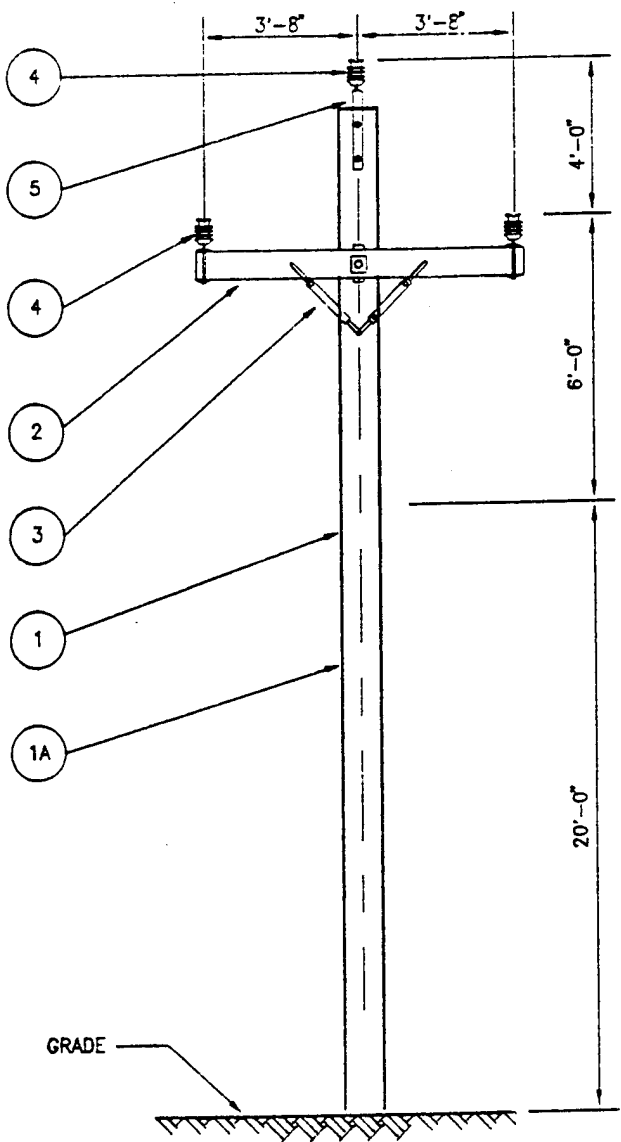

DETAIL (C)
SCALE: NONE

MORRISON KNUDSEN CORPORATION
ENVIRONMENTAL SERVICES GROUP

DISTRIBUTION GUY
AND ANCHOR DETAIL



DRAWN BY	APPROVED	CONTRACT NUMBER
CHECKED BY	SCALE	SHEET NUMBER 1651-16

BILL OF MATERIAL				
ITEM NO.	QUANTITY	DESCRIPTION	MFGR.	CAT. NUMBER
1		45FT, CLASS 4 DOUGLAS FIR POLE AS PER SPEC 37-1601, SECTION 8A		
2	1	8FT, 6 PIN WOODEN CROSS ARM		
3	1 SET	WOODEN CROSSARM BRACKET	JOSLYN	J4788-R
4	3	POLE TOP PIN INSULATORS, 14.4KV	AB CHANCE	C905-1305
5	1	POLE TOP PIN	JOSLYN	J1368

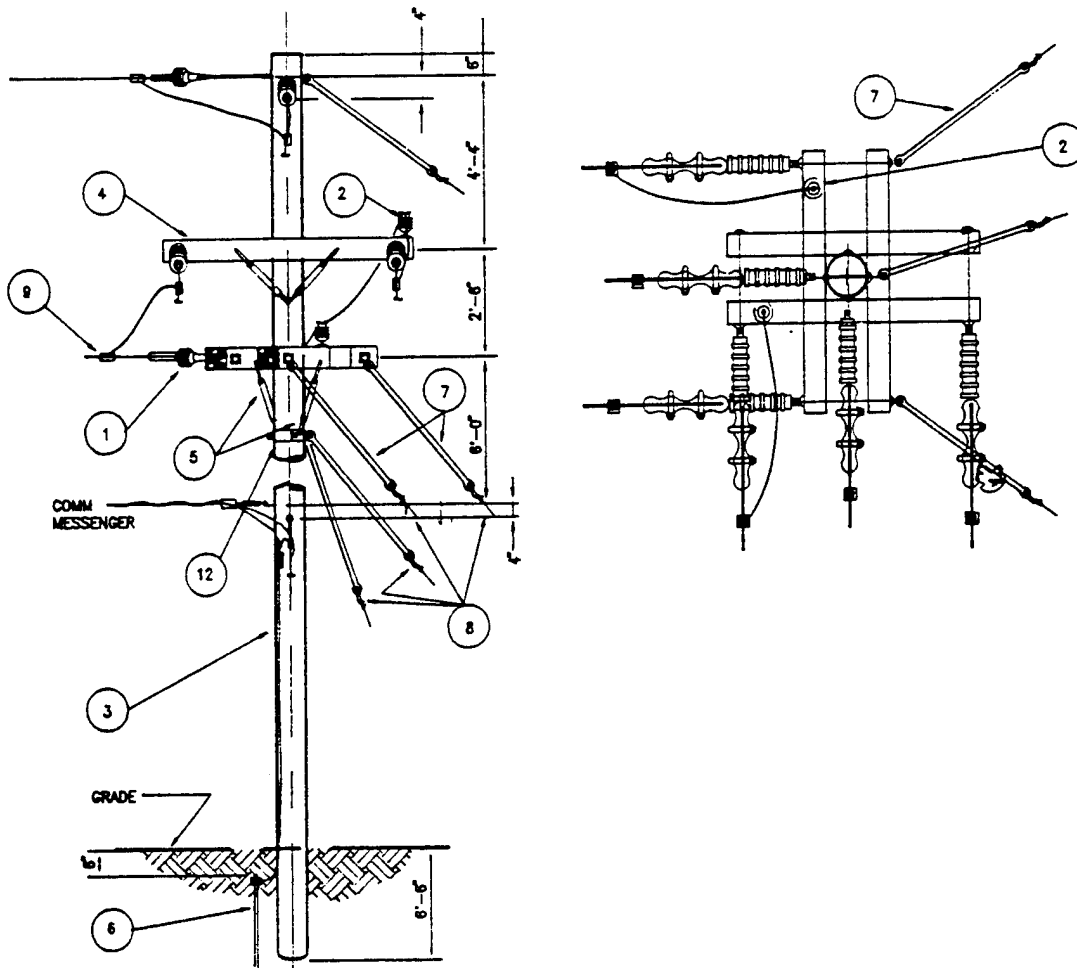

DETAIL B

BILL OF MATERIAL

ITEM NO.	QUANTITY	DESCRIPTION	MFGR.	CAT. NUMBER
1	6	DEADEND INSULATOR, 15KV, EPOXY	AB CHANCE	C654-0000
2	3	PIN INSULATORS, 14.4KV	AB CHANCE	C905-1305
3	1	45FT POLE, CLASS 4 DOUGLAS FIR		
4	4	8FT, 6 PIN WOODEN CROSSARM		
5	4 SETS	CROSSARM BRACE, WOODEN		
6	1	3/4" DIA x 10' LG COPPER GND ROD		
7	3	FIBERGLASS GUY ROD, 5/8" DIA x 8'		
8	FT	3/8" GUY WIRE		
9	6	PARALLEL CONNECTOR, 3 BOLT, ALUMINUM 3/0 ACSR - 2/0 cu	ANDERSON	LC-67A-XB
10	6	STRAIGHT LINE DEADEND STRAIN CLAMP 3/0 ACSR	ANDERSON	ASC-024-C
11	2	STRAIN INSULATOR, FIBERGLASS	HUGHES	CF993EE-18
12	1	POLE BAND W/2' GUY LINKS	HUGHES	3105.5



MORRISON KNUDSEN CORPORATION
ENVIRONMENTAL SERVICES GROUP

DISTRIBUTION GUY
AND ANCHOR DETAIL

DRAWN BY APPROVED CONTRACT NUMBER

CHECKED BY SCALE SHEET NUMBER

1651-17

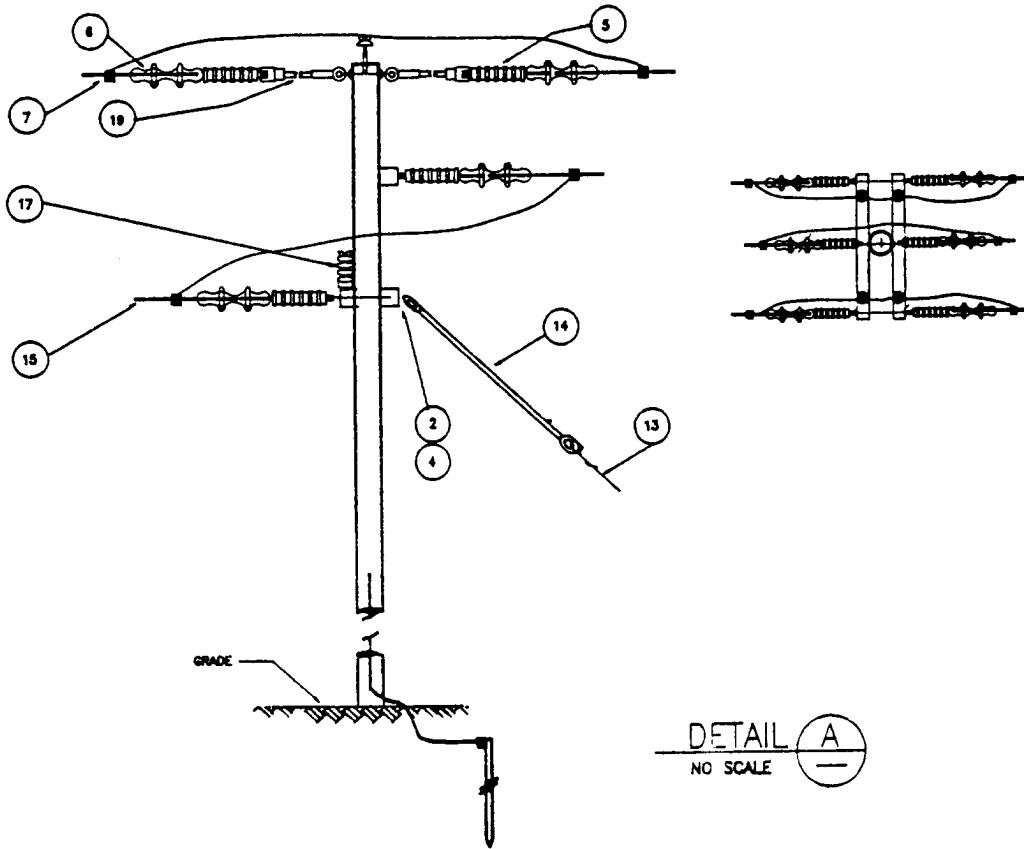

DETAIL A
NO SCALE

BILL OF MATERIAL

ITEM NO.	QUANTITY	DESCRIPTION	MFGR.	CAT. NUMBER
2	4	8 FT, 6 PIN WOODEN CROSS ARM		
4	5 SETS	WOODEN CROSS ARM BRACE	JOSLYN	J5100
5	6	DEADEND INSULATOR, 15 KV, EPOXY	AB CHANCE	C654-0000
6	6	STRAIGHT LINE DEAD END STRAIN CLAMP, 3/0 ACSR	ANDERSON	ASC-024-C
7	6	PARALLEL CONNECTOR, 3 BOLT 3/0 ACSR-2/0 cu	ANDERSON	LC-67A-XB
8	2	PIN INSULATOR, 14.4 KV	AB CHANCE	C905-1305
11	1	GROUND ROD, 3/4"x10' COPPER		
13		3/8" GUY WIRE		
14	3	FIBERGLASS GUY ROD 5/8" DIA x 8'	HUGHES	CF993CE-18
15	ft	3/0 ACSR OVERHEAD		
17	7	TIE POST INSULATOR, 14.4KV	AB CHANCE	C903-1910
18	7	GALVANIZED STEEL STUD FOR POST INSULATOR	AB CHANCE	C903-9500
19	2	POLE TOP PIN	JOSLYN	J-1266

MORRISON KNUDSEN CORPORATION
ENVIRONMENTAL SERVICES GROUP



DISTRIBUTION GUY
AND ANCHOR DETAIL

DRAWN BY APPROVED CONTRACT NUMBER

CHECKED BY SCALE SHEET NUMBER 1651-21

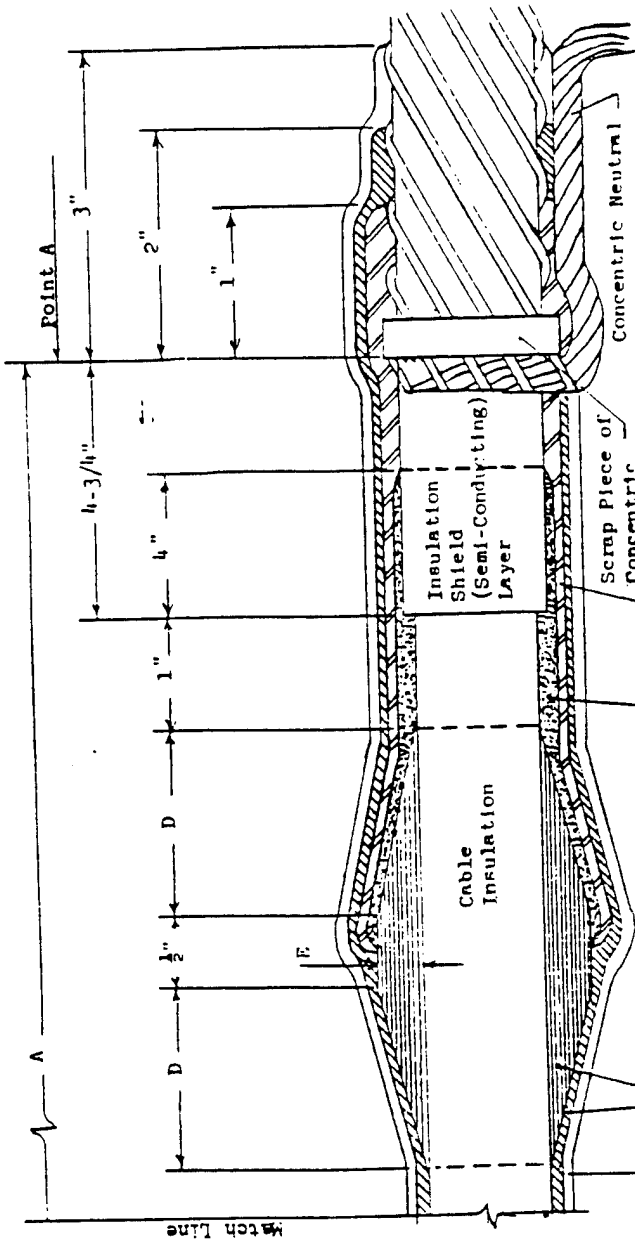

Terminal Dimensions	Rated kv Grounded Neutral
A	25
Indoors	25 in.
Outdoors	30 in.
B	1/2 in.
C	1 1/2 in.
D	3 1/2 in.
E	Insulation Thickness of Cable

(Not to Scale)

MORRISON KNUDSEN CORPORATION ENVIRONMENTAL SERVICES GROUP	
15 KV	
CABLE TERMINATION	
DRAWN BY _____ APPROVED BY _____ SCALE NONE	CONTRACT NUMBER _____ SHEET NUMBER 1631-22

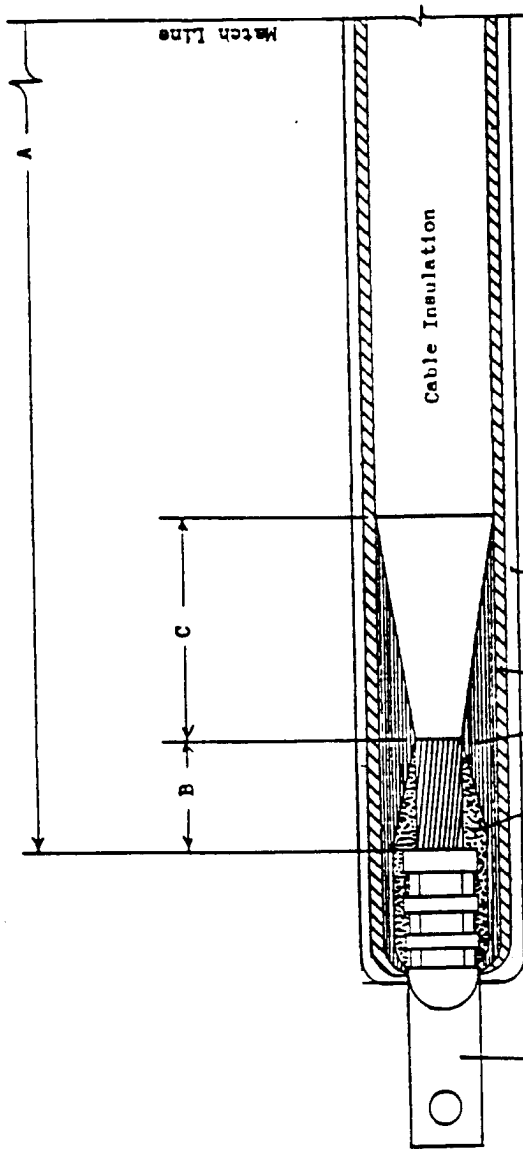

① Terminal Lug

② Conducting Shielding Tape

③ High-Voltage Insulating Tape

⑤ Terminating Silicone Rubber Tape

(Not to Scale)

Terminal Dimensions	Rated kV	Grounded Neutral
A	15	25
Indoors	25 in.	30 in.
Outdoors	30 in.	35 in.
B	3/4 in.	1/2 in.
C	1 1/4 in.	1 1/2 in.
D	3 1/2 in.	4 1/2 in.
E	Insulation Thickness of Cable	

 MORRISON KNUDSEN CORPORATION
ENVIRONMENTAL SERVICES GROUP

15 KV

LUG CONNECTION

DRAWN BY _____ APPROVED BY _____ CONTRACT NUMBER _____

CHECKED BY _____ SCALE NONE SHEET NUMBER 1831-23



SPECIFICATION 37-1655

ACCEPTANCE TESTING FOR ELECTRICAL POWER SYSTEMS

CLIENT: SHELL OIL COMPANY

PROJECT: ROCKY MOUNTAIN ARSENAL REMEDIATION PROJECT

INTERIM RESPONSE ACTION FINAL DETAILED DESIGN

RAIL CLASSIFICATION YARD/MOTOR POOL AREA IRA

LOCATION: ROCKY MOUNTAIN ARSENAL, COMMERCE CITY, CO



	<u>CONTENTS</u>	<u>PAGE</u>
1.	SCOPE	3
2.	APPLICABLE CODES, STANDARDS AND REFERENCES	3
3.	DIVISION OF RESPONSIBILITY	4
4.	GENERAL	5
5.	INSPECTION AND TEST PROCEDURES	6
6.	SYSTEM FUNCTION TESTS	10



SPECIFICATION 37-1655

ACCEPTANCE TESTING FOR ELECTRICAL POWER SYSTEMS

1. SCOPE

- A. This specification has been derived from work done by the National Electrical Testing Association, Inc. (NETA), Copyright 1979.
- B. The definitions for "Owner", "Engineer", and "Contractor" shall be as defined in specification section 37-1601.
- C. The Contractor shall provide all material, equipment, labor and technical supervision to perform tests and inspections.
- D. It is the intent of these tests to assure that all electrical equipment, both Contractor and Owner supplied, is operational within industry and manufacturer's tolerances and is installed in accordance with design specifications.
- E. The tests and inspections shall determine the suitability for energization.

2. APPLICABLE CODES, STANDARDS AND REFERENCES

- A. All inspections and tests shall be in accordance with the following applicable codes and standards except as provided otherwise herein.
 - 1) ANSI - American National Standards Institute
 - 2) ASTM - American Society for Testing and Materials
 - 3) FS - Federal Specifications
 - 4) IEEE - The Institute of Electrical and Electronics Engineers, Inc.
 - 5) ICEA - Insulated Cable Engineers Association
 - 6) NEMA - National Electrical Manufacturers Association



- 7) NFPA/ - National Fire Protection Association/
NEC National Electrical Code
- 8) NESC - National Electrical Safety Code
- 9) NETA - National Electrical Testing Association,
Inc.
- 10) OSHA - Occupational Safety and Health
Administration
- 11) UL - Underwriters' Laboratories, Inc.
- 12) Applicable State of Colorado Electrical, Building
and Safety Codes
- 13) NIST - National Institute of Standards and
Technology

B. The following item of related work is covered in other specifications but is not included in the scope of the work described herein:

- 1) Electrical Work (Specification 37-1601)

3. DIVISION OF RESPONSIBILITY

- A. The Contractor shall perform routine insulation resistance, continuity and rotation tests for all distribution and utilization equipment.
- B. The Contractor shall supply a suitable and stable source of test power.
- C. The Contractor shall notify the Field Engineer when equipment becomes available for acceptance tests. Work shall be coordinated to expedite project scheduling.
- D. The Contractor shall notify the Field Engineer prior to commencement of any testing.
- E. The Contractor shall be responsible for implementing all final settings and adjustments on protective devices and tap changers in accordance with Engineer's specified values.
- F. Any system material or workmanship which is found defective on the basis of acceptance tests shall be reported directly to the Field Engineer.



- G. The Contractor shall maintain a written record of all tests, and upon completion of project, shall submit such records to the Engineer.

4. GENERAL

A. Test Instrument Traceability:

- 1) The Contractor shall have a calibration program which maintains all applicable test instrumentation within rated accuracy.
- 2) Instruments shall be calibrated in accordance with the following frequency schedule:
 - a) Field instruments - 6 months maximum.
 - b) Leased specialty equipment - 12 months. (Where accuracy is guaranteed by lessor.)
- 3) Dated calibration labels shall be visible on all test equipment.

B. Test Report:

- 1) The test report shall include the following:
 - a) Name of project
 - b) Description of equipment tested.
 - c) Description of test.
 - d) List of test equipment used in calibration and calibration date.
 - e) Test results.
 - f) Conclusions and recommendations.
 - g) Appendix, including appropriate test forms.
- 2) The test report shall be bound and its contents certified.
- 3) Furnish copies of the completed report to the Engineer no later than 30 days after completion of project unless directed otherwise.



C. Safety and Precautions:

- 1) Safety practices shall include, but are not limited to, the following requirements:
 - a) Occupational Safety and Health Administration - OSHA.
 - b) Accident Prevention Manual for Industrial Operations, National Safety Council.
 - c) Applicable State and Local safety operating procedures.
- 2) All acceptance tests shall be performed with apparatus de-energized except where otherwise specifically required in Sections 5 and 6.
- 3) The Contractor shall have a designated safety representative who shall be present on the project and supervise operations with respect to safety.
- 4) Circuits operating in excess of 600 volts between conductors shall have conductors shorted to ground by a hot-line grounding device approved for the purpose.
- 5) In all cases, work shall not proceed until the safety representative has determined that it is safe to do so.
- 6) The Contractor shall have available sufficient protective barriers and warning signs to conduct specified tests safely.

5. INSPECTION AND TEST PROCEDURES

A. Cables - Low Voltage (600 Volts and Less):

- 1) Visual and Mechanical Inspection:
 - a) Cables to be inspected for physical damage and proper connection in accordance with one-line diagram.
 - b) Cable connection shall be torque tested to manufacturer's recommended values.



- c) Heat trace circuits shall be tested prior to and following the installation of pipe insulation.
- 2) Electrical Tests:
 - a) Perform insulation resistance test on each cable with respect to ground and adjacent cables.
 - b) Perform continuity test to ensure proper cable connection.
- 3) Test Values:
 - a) Insulation resistance tests shall be performed at 1000 volts dc for one-half minute.
 - b) When insulation resistance must be determined with all switchboards, panelboards, fuse holders, switches, and overcurrent devices in place, the insulation resistance when tested at 500 volts dc shall be no less than Table 1.

TABLE 1

MINIMUM INSULATION RESISTANCE

<u>CONDUCTOR OR CIRCUIT SIZE</u>	<u>MINIMUM RESISTANCE</u>
No. 14 and No. 12 AWG	1,000,000 ohms
25-ampere circuits and above	250,000 ohms

B. Circuit Breakers - Low Voltage (Molded Case):

- 1) Visual and Mechanical Inspection:
 - a) Circuit breaker shall be checked for proper mounting, conductor size, and feeder designation.
 - b) Operate circuit breaker to ensure smooth operation.
 - c) Inspect case for cracks or other defects.
 - d) Check tightness of connection with torque wrench in accordance with manufacturer's recommendations.



- 2) **Electrical Tests:** An insulation resistance test shall be performed at 1000 volts dc for one (1) minute from pole to pole and from each pole to ground and across open contacts of each phase.
- 3) **Tests Values:** Insulation resistance shall not be less than 50 megohms.

C. Grounding Systems:

- 1) **Visual and Mechanical Inspection:** Inspect ground system for compliance with plans and specifications.

D. Motor Starters:

- 1) **Visual and Mechanical Inspection:**
 - a) Inspect for physical damage, proper anchorage and grounding.
 - b) Compare equipment nameplate data with design plans or starter schedule.
 - c) Compare overload heaters with motor full load current for proper size.
 - d) Check tightness of bolted connections.
- 2) **Electrical Tests:**
 - a) **Insulation Tests:** Measure insulation resistance of each starter section phase to phase and phase to ground with the starter contacts closed and the protective device open. Test voltage and minimum acceptable values in accordance with Paragraph 3 below.
 - b) Perform operational tests by initiating control devices to affect proper operation.
- 3) **Test Values:** Insulation resistance test to be performed in accordance with Table 2.



TABLE 2

INSULATION RESISTANCE TEST VOLTAGE

<u>VOLTAGE RATING</u>	<u>TEST VOLTAGE</u>
150 - 600 V	1000 V

Values of insulation resistance less than manufacturer's minimum or $kV + 1$ in megohms should be investigated.

E. Rotating Machinery:

- 1) Visual and Mechanical Inspection:
 - a) Inspect for physical damage.
 - b) Compare equipment nameplate information with one-line diagram and report discrepancy.
 - c) Inspect for proper anchorage, mounting, grounding and connection.
 - d) Inspect for proper lubricant levels.
 - e) Special tests as suggested by manufacturer, such as gap spacing and pedestal alignment, shall be made where applicable.
 - f) A motor run-in test shall be performed for one hour. During the test, check for bearing heat, and excessive heat or vibration.
- 2) Electrical Tests:
 - a) Perform insulation resistance test on all motors.
 - b) A rotation test shall be made to insure proper shaft direction.
 - c) Measure no load and full load running current and compare to nameplate.
 - d) Check all protective devices in accordance with other sections of these specifications.



- 3) Test Values:
 - a) Motor measured full load current shall not exceed nameplate value.
 - b) Insulation resistance test to be performed in accordance with Table 2.

6. SYSTEM FUNCTION TESTS

A. General:

- 1) Each system specified under Section 5 shall be function tested to ensure total system operation.
- 2) Upon completion of equipment tests as defined in Section 5, the system function tests shall be performed. It is the intent of system functional tests to prove the proper interaction of all sensing, processing and action devices to effect the design end product or result.
- 3) Implementation:
 - a) The Contractor shall develop a test matrix which consists of:
 - Input signal and stimuli. Example:
Start Pushbutton
Level Switch
 - Decision process. Example:
Motor Control Logic
 - Action device. Example:
Motor Starter
 - End product or result. Example:
Motor Starts or Stops as required
 - b) All interlocks, safety devices, and fail safe functions shall be tested in addition to design function.



MORRISON KNUDSEN CORPORATION
ENVIRONMENTAL SERVICES GROUP

SPEC NO.: 38-3750
W.O. NO.: 2127-22
DATE: 11/30/90
ISSUE/REV.: 0
PAGE: 1

SPECIFICATION 38-3750

INSTRUMENTATION WORK

CLIENT: SHELL OIL COMPANY

PROJECT: ROCKY MOUNTAIN ARSENAL REMEDIATION PROJECT

INTERIM RESPONSE ACTION FINAL DETAILED DESIGN

RAIL CLASSIFICATION YARD/MOTOR POOL AREA IRA

LOCATION: ROCKY MOUNTAIN ARSENAL, COMMERCE CITY, CO



TABLE OF CONTENTS

<u>Contents</u>	<u>Page</u>
1. SCOPE	3
2. DEFINITIONS	3
3. WORK INCLUDED	3
4. RELATED WORK	4
5. REFERENCED DOCUMENTS	4
6. RECEIVING, INSPECTION, AND STORAGE	5
7. GENERAL INSTALLATION PROCEDURES	6
8. TUBING/PIPING PROCEDURES	7
9. ELECTRICAL PROCEDURES	9
10. CALIBRATION PROCEDURES	10
11. COMMISSIONING PROCEDURES	13
12. PLANT START-UP ASSISTANCE	15
13. SAFETY	16
14. WORKMANSHIP	16
15. AS-BUILTS	16
16. CALIBRATION AND COMMISSIONING REPORTS	17
17. INDEX OF ATTACHED DOCUMENTS	17



SPECIFICATION 38-3750

INSTRUMENTATION WORK

1. SCOPE

A. This specification covers the receiving, storing, installing, calibrating, commissioning, and assisting in the start-up of instrumentation and controls. It also includes the furnishing and installing of instrument tubing, piping, and all miscellaneous material as specified herein.

2. DEFINITIONS

A. The term "Contractor" as used herein shall mean the "Instrumentation Contractor." The term "Engineer as used herein shall mean the "Morrison-Knudsen Engineers, Inc. Project Engineer" or his designated representative. the term "Owner" as used herein shall mean the firm name in the project title for whom the facility is being constructed.

3. WORK INCLUDED

A. Included in the scope of work for the Contractor is the following:

- 1) Receiving, uncrating, inspecting and storing of instruments, controls, control panels, instrument tubing and piping, and miscellaneous instrumentation materials at the project site.
- 2) Protecting all equipment and devices from damage from the time of receipt until acceptance by the Owner.
- 3) Furnishing all necessary instrumentation materials required to perform the specified work.
- 4) Installing, in a neat and workmanlike manner, the instruments, controls, control panels, instrument tubing and piping, and miscellaneous instrumentation materials, as specified herein, including instruments furnished with purchased equipment, unless otherwise directed by the Engineer.
- 5) Providing all necessary labor, tools, test equipment and other equipment to test, calibrate and commission the instruments and controls, including



those furnished with purchased equipment, after installation and prior to start-up.

- 6) Furnishing of start-up assistance required, including all necessary labor, tools, test equipment, and materials.

4. RELATED WORK

A. The following related work, to be performed by others, is covered in other specifications:

- 1) Furnishing of instrumentation (Specification 38-3799)
- 2) Process and utility piping (Specification 35-1501)
- 3) Electrical work, including thermocouple lead wire and shielded cable for instrumentation signal leads; and connecting of same (Specification 37-1601)
- 4) Field painting (Specification 33-0914)
- 5) Electrical control panel (Specification 37-1608)

5. REFERENCED DOCUMENTS

A. The following referenced standards, drawings, and specifications, or the latest revision thereof, shall be adhered to where applicable.

B. Organizations whose standards are referenced herein include the following:

- 1) ISA - Instrument Society of America
- 2) ASTM - American Society for Testing and Materials
- 3) NIST - National Institute of Standards and Technology
- 4) NEC - National Electrical Code as adopted by the National Fire Protection Association
- 5) OSHA - Occupations Safety and Health Administration

C. The following engineering documents are attached, as itemized at the end of this specification:

- 1) Instrument Index (Specification 38-3799)



- 2) Instrument Data Sheets (Specification 38-3799)
 - 3) Instrument Loop Drawings
 - 4) Instrument Installation Details
 - 5) P&I Drawings
 - 6) Instrument Location Drawings
 - 7) Control Panel Drawings
- D. All work under this specification shall meet or exceed all applicable federal, state or local codes and regulations. In the event of discrepancy, the most stringent shall apply.
- E. In the event of any discrepancy between the specification and construction drawings, reference documents, standards or codes, the Contractor shall bring such discrepancies to the attention of the Engineer for resolution.

6. RECEIVING, INSPECTION, AND STORAGE

- A. All instrumentation equipment and devices shall be received, inspected, and stored by this Contractor per procedures defined and coordinated through the Engineer.
- B. Receiving reports shall be prepared for all incoming instrumentation items, and shall be sent to the Engineer on a regular basis, as established by the Engineer.
- C. Incoming items shall be checked against the purchase order and/or packing list, for proper tagging, general physical condition, and missing parts. Any discrepancies shall be noted on the receiving report.
- D. All items shall be stored such that they are protected from moisture, foreign material, and damage. The location shall be documented so that the items are readily retrievable.
- E. This work shall also include inspecting and storing instrumentation items received at the project site prior to the start of this Contractor's operations.
- F. Contractor shall not be responsible for damage to instrument items received at the site prior to the start of Contractor's operations. However, any such damage to these items by others, shall be reported to the Engineer.



- G. Once received and accepted, this Contractor shall be responsible for all damage to these items handled under this specification, assuming all costs for necessary repairs and/or replacements.

7. GENERAL INSTALLATION PROCEDURES

- A. The Instrument Index furnished with Specification 38-3799 (Instrument Data Sheets) lists all instruments on this project, together with a cross-reference to drawings, such as loop, installation details, piping, location, etc.
- 1) All items listed with location code F (field mounted) shall be installed by the Contractor.
 - 2) All other items are installed by others; e.g., items with location code L (line mounted) shall be installed by the piping contractor (refer to Related Work).
 - 3) All items listed in the Index shall be calibrated and commissioned by the Contractor, unless specifically noted otherwise.
- B. Before installation, each item shall be checked against the corresponding Instrument Data Sheet to assure that model numbers, materials of construction, ancillary equipment, and miscellaneous features are as stated on the Data Sheet. Discrepancies shall be brought to the attention of the Engineer.
- C. The established installation locations of instruments and associated apparatus may not be changed without the written approval of the Engineer.
- D. Instruments located in a damp or wet location, as defined by the NEC (e.g., underground, or against earth), shall be placed and mounted as prescribed by the NEC to prevent entry of moisture. In particular, instruments of the surface mounting type shall be mounted such that a $\frac{1}{4}$ -inch minimum air space is maintained between the instrument and the supporting structure.
- E. All work shall be performed in accordance with the furnished installation drawings, this specification and/or the manufacturer's recommended installation instructions and drawings. Questions or conflicts shall be resolved with the Engineer.



- F. Proper crafts shall be employed as required for installation of all instruments, controls, panels and instrument piping or wiring needed under this specification.
- G. All work shall be coordinated with related work specified under other specifications so that complete installations may be turned over to the Owner fully tested and ready for operation.
- H. The Contractor shall provide all labor, tools, construction equipment and test equipment, and make tests, calibrations and keep such records thereof as specified herein.

8. TUBING/PIPING PROCEDURES

A. Material:

- 1) Pipe and pipe fittings used in instrument service shall conform to the project piping Specification 35-1501, "GENERAL SPECIFICATION FOR PIPING", and the drawings referenced in this specification (38-3750).
- 2) Copper tubing shall be soft annealed seamless tubing, per ATM B75 or equivalent.
- 3) Stainless steel tubing shall be fully annealed high quality type 316 hydraulic tubing, per ASTM A269 or Engineer approved equal, suitable for bending and flaring.
- 4) The minimum wall thicknesses for pipe nipples 12" and shorter, and for metal tubing, shall be as follows:

	<u>Nominal</u>	<u>Pipe Nipple Schedule</u>		<u>Metal</u>
		<u>Steel</u>	<u>Stainless Steel</u>	<u>Copper</u>
	<u>Size</u>			
<u>Stainless Steel</u>				
1/4	80	40	0.035	0.028
3/8	80	40	0.049	0.035
1/2	40	40	0.065	0.049
3/4 & 1	40	40	-----	-----

- 5) Polyethylene tubing, 1/4" OD x 0.040" wall minimum, contained in multitube bundles, shall be used only between panelboards and remotely located junction



boxes. Bundles shall contain a minimum of 20% spare tubes.

- 6) Tubing fittings shall be Crawford Swagelok type or Engineer approved equal.

B. Installation:

- 1) Material, and method of installation, shall be as specified herein, and shall be in accordance with the installation details given on the applicable drawings.
- 2) The general routing shown on the piping drawings shall be followed with tubing parallel to principal lines of equipment and/or building walls. Alternate routes may be selected subject to approval of the Engineer.
- 3) All 1" and smaller, instrument air supply lines from block valves at air headers, and transmission control and process sensing piping with required valves, tubing, fittings, hangers, supports, etc., shall be installed under this specification.

Block valves and process sensing connections are not part of the Contractor's responsibilities under this specification (see reference specification 35-1501).

- 4) Low points of instrument air headers shall be equipped with blowdown valves.
- 5) All tubing shall be installed in a uniform and workmanlike manner free of kinks, wrinkles, flat spots and unnecessary bends. Single tubing runs of 2 feet or more shall be supported continuously. Makeshift or untidy appearing brackets will not be accepted.
- 6) Individual instruments requiring air supply shall each be provided with a block valve mounted near the instrument and upstream of the filter-regulator furnished for the instrument.
- 7) Two or more field mounted instruments, located in the same general vicinity, may receive air from a manifold provided with a dual filter-regulator set (with valves), and a shutoff valve for each instrument.



- 8) Where conduit is used for multitube bundles, it shall be rigidly attached to the junction box. Bulkhead unions shall be used to connect individual tubing within the junction box. Small radius bends and sharp corners shall be avoided for installation of multitube bundles and trays.
- 9) Each tubing bulkhead union shall be tagged with a plastic tag to identify the associated instrument.
- 10) The ends of all unused spare tubes in multitube bundles shall be coiled, sealed (crimped if metal, plugged if plastic), and tagged as spares in the junction box and/or at the panelboard.
- 11) Capillary tubing for filled system temperature and pressure instruments shall be protected by installation in channel supports, with capillary attached to channel with clips. Excess capillary tubing shall be coiled and secured neatly at the instrument.

9. ELECTRICAL PROCEDURES

- A. All wiring and conduit runs shall be by the electrical subcontractor, and is not included in the scope of this specification.
- B. Connecting the wiring referred to in Paragraph 4.A to the instruments shall be done under the supervision of the Instrumentation Contractor, in accordance with the loop drawings.
- C. Shields on instrumentation wires and cables shall be handled as follows, unless specifically shown otherwise on the loop drawings:
 - 1) If not shown connected to a terminal at or near the instrument, the shield shall be cut and carefully taped to prevent moisture from entering the cable.
 - 2) Shields shall be electrically continuous from instrument to instrument, using terminal blocks at any intervening junction boxes. No splices are permitted.
 - 3) Shields shall be isolated from ground, and shall be terminated in the control panel at an isolated ground bus.



- D. Local cables supplies as part of the instrumentation (e.g., between pH sensors and the transmitter) shall be installed and connected by the (instrument) Contractor in accordance with the loop drawings.

10. CALIBRATION PROCEDURES

- A. General: Calibration is part of the commissioning process which is further described elsewhere in this specification. Calibration shall consist of comparing the observed or measured output with the desired or calculated output, at one or more specific values of the input or inputs. It shall also include correcting the actual output to agree with the desired output. Measurement of input and output values shall incorporate calibration equipment as described in the following paragraphs.

- 1) All instrumentation items listed in the Instrument Index, including the components specified in the corresponding Instrument Data Sheets, shall be calibrated, unless exempted by the Engineer. Refer to guidelines given in the following paragraphs (see Calibration Methods) to determine exemptions. If exempted from calibration, the item shall be functionally checked.
- 2) Instruments maybe bench calibrated, or calibrated as installed. If the latter, the electrical and/or pneumatic hookup shall first be checked, as described in the Commissioning Procedures, Paragraph 11.
- 3) Instruments having continuously variable outputs (e.g., 4-20 mA, variable frequency, etc.) shall receive a 5-point calibration (e.g., 0, 25, 50, 75, and 100% of input span) with both ascending and descending inputs, for a total of ten calibration points. Desired output values shall be determined from the range, characteristics, and/or equations indicated on the Instrument Data Sheet.
 - a) When the accuracy is not within the limits stated o the Data Sheet, or by the instrument manufacturer, it shall be corrected by resetting the instrument adjustments (zero, span, linearity, etc.)
 - b) When the accuracy is, or has been brought to be, within the manufacturer's stated limits, the measured input and output values shall be



recorded in a calibration report similar to that included at the end of this specification.

- 4) Instruments having discrete outputs (e.g., pressure switches) shall be calibrated such that trip-points are at the values given on the Data Sheets or Drawings.
- 5) If, during calibration or functional check of the instrument, any reason is discovered to question the performance or operation, the correctness of the model number, or the method of installation, the Engineer shall be notified so that corrective action may be taken.
- 6) A calibration report shall be submitted to the Engineer similar to that included at the end of this specification. The information given in the report shall at least include the following for each instrument calibrated.
 - a) Project name
 - b) Instrument tag number, manufacturer and model number, and Instrument Data Sheet number
 - c) Name of person calibrating
 - d) Calibration equipment used (serial or tag numbers)
 - e) Measured values, desired or calculated values, and deviation in percent of span
- 7) Instruments functionally checked and not calibrated shall be noted in the commissioning report with the date checked and the initials of the checker. An example of such a report is included at the end of this specification.
- 8) A calibration tag or sticker shall be attached to each item after calibration or checking. The date calibrated or checked, and the initials of the calibrator/checker, shall appear on this tag or sticker.

B. Calibration Equipment:

- 1) All calibration equipment used in accordance with this specification shall be traceable to the



National Institute of Standards and Technology in an unbroken chain.

- 2) Each calibration device shall be uniquely identifiable by serial number or tag number, so that it can be checked against the traceability records.
- 3) Each calibration device shall be periodically checked against secondary standards in accordance with the recommendations of the National Institute of Standards and Technology.
 - a) The frequency of checking against secondary standards shall be as required to maintain the calibration accuracies specified herein.
 - b) The date the latest check against secondary standards shall be noted by sticker or tag on each calibration device.
- 4) Acceptable calibration equipment include, but are limited to, the following:
 - a) Precision pressure gauges
 - b) Precision thermometers
 - c) Dead weight testers
 - d) Precision decade boxes for resistance and capacitance
 - e) Electronic signal calibrators (Transmation Model 1040 or equal)
 - f) Thermocouple and EMF calibrators (Transmation Model 1068 or equal)

C. Calibration Methods:

- 1) In general, all instruments and components with readily accessible adjustments shall be calibrated, using the manufacturer's recommendations. Where the Engineer specified special calibration, a procedure will be supplied to this contractor.
- 2) The intent of the calibration method is to assure that the instrument adjustments are at the proper settings, as determined by the Instrument Data Sheets. It is not the intent to require elaborate and expensive methods just to include non-adjustable



portions of the instrument in the calibration procedure.

- 3) Each instrument and component shall be visually checked for compliance with the specifications on the Instrument Data Sheet, with the installation drawings, and with the manufacturer's recommended installation practice.
- 4) All shipping stops shall be removed before any operational check is initiated.
- 5) Clean, dry air (hand pump or instrument air supply) or nitrogen shall be used as a source of pressure when calibrating pressure and differential pressure devices.
- 6) Items not needing calibration include the following:
 - a) Pressure and level gauges
 - b) Dial thermometers
 - c) Self-contained regulators (flow, pressure, temperature)
 - d) Primary elements (orifice plate, venturi, etc.)
- 7) When it is not practical to calibrate the complete instrument, those components not having readily accessible adjustments may be omitted in the calibration method. The manufacturer's recommendations shall be used as the basis for calibrating the rest of the instrument, and the entire instrument shall be functionally checked. Examples of components in this category are as follows:
 - a) Displacer mechanism of a level transmitter
 - b) Meter body and coils of a magnetic flow meter

11. COMMISSIONING PROCEDURES

- A. Commissioning of an instrument or instrument loop shall consist of all steps necessary to place the item or system in proper operational status, ready for start up. As such, it shall include at least the following steps:
 - 1) Assure that instrument sensing lines have been cleaned and flushed out.



- 2) Check (and correct as necessary) the installation of each instrument for compliance with installation drawings and manufacturer's recommended installation and practice.
 - 3) Check (and correct as necessary) the electrical and/or pneumatic hookup for compliance with loop drawings. Any apparent errors in the loop drawings shall be brought to the attention of the Engineer.
 - 4) Perform a calibration or functional check on each item.
 - 5) Check for proper settings of alarm points, pressure switches, relief valves, control points, etc.
 - 6) Check "zero" adjustments of pressure gauges, dial thermometers, differential pressure instruments, etc.
 - 7) Check for proper status of all instrument isolation valves.
 - 8) Document all steps in the commissioning report (see form at end of this specification).
- B. A commissioning report shall be generated and kept current, showing the status of all instrumentation listed in the Instrument Index. The steps in the commissioning process shall be documented for each instruments, with dates of performance and initials of the performer. An example of a commissioning report is included at the end of this specification.
- C. Electrical wiring to each instrument shall be checked for compliance with instrument loop drawings, prior to admitting power to the instrument.
- 1) Check for wiring continuity and insulation integrity.
 - 2) Check ground wiring, being particularly attentive to ground loops, multiple grounds, and instrument grounds not isolated from electrical power grounds.
 - 3) Check instrument power connections for voltage level, type (ac or dc), and polarity.
- D. Instrument air header and sub-headers shall be "blown down" and leak tested prior to admitting air to any



instruments. A soap bubble test shall be used to locate leaks at all joints and connections in the air supply lines. All leaking joints shall be repaired and the lines retested.

- E. Pneumatic tubing circuits shall be blown down and tested for continuity and leak tightness.
- 1) Continuity Test: Apply a 20 psig air supply to the tubing under test, with tubing disconnected from the instrument and check for free flow of air.
 - 2) Leak Tightness Test: shall conform in general to that outlined in the ISA Standard RP7.1, "PNEUMATIC CONTROL CIRCUIT PRESSURES TEST". Whenever possible, the instruments shall remain connected during the test so that they may be tested simultaneously. Allowance shall be made, in the duration of the test, to compensate for additional volume in the instrument. When tubing terminates in a large valve diaphragm housing, or other large volume, it may be disconnected, plugged and tested. After a tubing test has been completed, tubing shall be reconnected to instrument, and connections that were broken shall be bubble tested, repaired if needed, and retested.
- F. Control loop checkout or commissioning, involving the activities needed to prove out a control loop, shall normally be performed when all loop connections are complete, and shall include the operations indicated below. Calibration may be performed during the loop checkout.
- 1) Check controller action.
 - 2) Check pressure and/or limit switch action and setting.
 - 3) Verify proper stroking of control valves.
 - 4) Check alignment of controllers, valves, positioners and other control devices, including auto-manual stations.
 - 5) Check interlock action and annunciator action.

12. PLANT START-UP ASSISTANCE

- A. After completion of testing, calibrating and commissioning operations, start-up assistance shall be



provided as required. It shall include, but not be limited to, the following:

- 1) Adjust controls for stability.
- 2) Reset limit switches, as required, at the Engineer's direction.
- 3) Clean out blocked or restricted impulse lines.

13. SAFETY

- A. All work and working conditions shall conform to established federal, state and local laws and regulations, including specific rules and regulations established at the site by the Engineer and/or Owner.
- B. Certain areas are classified "hazardous locations" as defined by Chapter 5 of the NEC. All instrumentation equipment and work in these areas shall comply with the requirements of NEC, the applicable Standards and Recommended Safeguards of the NFPA, and the Occupational Safety and Health Administration (OSHA).
- C. Hazardous areas and their classifications are as noted on the drawings and as follows:

14. WORKMANSHIP

- A. The Contractor shall assign persons in direct charge to the work who are thoroughly experienced in the class of construction work specified herein and upon request by the Engineer shall attest, in writing, to the competency of such persons. All labor shall be performed in a workmanlike manner by skilled workmen under the supervision of competent foremen.
- B. The Contractor shall periodically remove all accumulations of waste material or rubbish caused by his employees or work in order to maintain safe working and operating conditions, and shall dispose of such debris in a manner approved by the Engineer. At the completion of the work, he shall remove all his rubbish, tools, scaffolds and surplus materials from or about the site, leaving his work area clean and ready for occupancy.

15. AS-BUILTS

- A. One (1) complete set of drawings issued for this contract shall be maintained exclusively for record purposes by the Contractor and all significant changes and



modifications shall be shown and noted thereon in red color. Supplemental drawings or sketches may be added. Dimensions, clearances, sizes and significant references shall be added.

- B. Drawings shall be kept neat and clean, and shall be available to the Engineer at all times for reference. All sketches, notes and data shall be sufficiently clear to permit photo reproductions when needed.

16. CALIBRATION AND COMMISSIONING REPORTS

- A. The paragraphs on Calibration Procedures and Commissioning Procedures refer to required calibration and commissioning reports. The following two pages show acceptable forms of these reports.

17. INDEX OF ATTACHED DOCUMENTS

Specification 38-3799 Instrument Data Sheets (with Index)

Dwg. #IDSF1 & IDSF2 Installation Details

Dwg. #37804-38-001 P&I Drawing
37804-38-002
37804-38-003
37804-38-004
37804-38-005
37804-38-006
37804-38-007

Dwg. #37804-37-0007A Loop Drawing
37804-37-0007B

Dwg. #37804-37-0007C Instrument Control Panel Drawing
37804-37-0007D

Dwg. #37804-37-001 Instrument Location Drawings
37804-37-002A
37804-37-002B

Dwg. #37804-37-004A Well Control Panel
37804-37-004B
37804-37-004C
37804-37-004D
37804-37-004E
37804-37-004F
37804-37-004G



SPECIFICATION 38-3799

INSTRUMENT DATA SHEETS

CLIENT: SHELL OIL COMPANY

PROJECT: ROCKY MOUNTAIN ARSENAL REMEDIATION PROJECT

INTERIM RESPONSE ACTION FINAL DETAILED DESIGN

RAIL CLASSIFICATION YARD/MOTOR POOL AREA IRA

LOCATION: ROCKY MOUNTAIN ARSENAL, COMMERCE CITY, CO

Mounting Code: F - field mounted; L - line mounted; P - panel mounted
R - rack mounted; T - tank mounted; V - vendor mounted



INSTRUMENTATION INDEX

<u>TAG NUMBER</u>	<u>SERVICE/APPLICATION</u>	<u>No.</u>	<u>DATA SHEET</u>		<u>P&I DRAWING</u>	<u>MTNG</u>	<u>NOTES</u>
			<u>Rev.</u>				
FE/FQI 301 thru FE/FQI 307	Dewatering well flow measurement, indication and totalizing	1	0		37804-38-005	F	
FE/FQI 401 and FE/FQI 402	Dewatering well flow measurement, indication and totalizing	1	0		37804-38-005	F	
FE/FT-103	Bag pre-filter flow measurement and transmitter	2	A	0	37804-38-002	F	
		2	B	0			
LE/LSL/LSH /LSHH-201	Influent wet well pump control	3	0		37804-38-002	F	
LSH/LSL/LE 301 thru LSH/LSL/LE 307	Dewatering well pump control	4	0		37804-38-005	F	
LSH/LSL/LE 401 LSH/LSL/LE 402	Dewatering well pump control	4	0		37804-38-005	F	
FV-103	Bag pre-filter flow control valve	5	0		37804-38-002	F	
LCV-201	Influent wet well flow control valve	6	0		37804-38-002	F	
PI-301 thru PI-307	Dewatering well transmission pipeline pressure	7	0		37804-38-005	F	
PI-401 thru PI-402	Dewatering well transmission pipeline pressure	7	0		37804-38-005	F	

Mounting Code: F - field mounted; L - line mounted; P - panel mounted
R - rack mounted; T - tank mounted; V - vendor mounted



INSTRUMENTATION INDEX

<u>TAG NUMBER</u>	<u>SERVICE/APPLICATION</u>	<u>No.</u>	<u>DATA SHEET</u>		<u>MTNG</u>	<u>NOTES</u>
			<u>Rev.</u>	<u>P&I DRAWING</u>		
PI-103	Groundwater treatment facility transmission pipeline pressure	8	0	37804-38-002	F	
PI-108				37804-38-003		
PI-109						
PI-201						
FIC-103	Bag pre-filter controller	9	0	37804-38-002	P	
PSV-110	Carbon adsorber pressure relief valve	10	0	37804-38-003	F	
FE/FQI- 108	Cartridge Post Filter Influent Flow	11	0	37804-38-003	F/L	
FE/FQI- 201	Groundwater Treatment Facility Influent Flow	12	0	37804-38-002	F/L	
FV-202	Influent Wet Well Flow Valve	13	0	37804-38-002	F/L	
PSV-108A & PSV-108B	Post Bag Filter Pressure Safety Valve	14	0	37804-38-003	F	
PSV-511 thru PSV-514	Irondale System Extraction Well Pressure Safety Valve	15	1	37804-38-006	F	
FE/FQI- 511 thru FE/FQI- 514	Irondale System Extraction Well Effluent Flow	16	1	37804-38-006	F	

Mounting Code: F - field mounted; L - line mounted; P - panel mounted
 R - rack mounted; T - tank mounted; V - vendor mounted



INSTRUMENTATION INDEX

<u>TAG NUMBER</u>	<u>SERVICE/APPLICATION</u>	<u>No.</u>	<u>DATA SHEET</u>		<u>MTNG</u>	<u>NOTES</u>
			<u>Rev.</u>	<u>P&I DRAWING</u>		
LSH/LSL/LE -511 thru LSH/LSL/LE -514	Irondale System Extraction Well Pump Control	17	1	37804-38-006	F	
TC-511 thru TC-514	Irondale System Extraction Well Heat Tracing Temperature Control	18	1	37804-38-006	F	
LE/LSLL/LS L/LSH/LSHH -500	Effluent Sump Level Switch	19	0	37804-38-007	F	
FE/FQI- 502	Irondale Existing Recharge Well Manifold Flow	20	0	37804-38-007	F	
FE/FQI- 501	Irondale Reinjection Wells Flow	20	0	37804-38-007	F	
PI-501	Irondale Reinjection Wells Pressure	22	0	37804-38-007	F	
PI-502	Irondale Existing Recharge Well Manifold Pressure	22	0	37804-38-007	F	
TC-500, TC-501 & TC-502	Irondale Reinjection Sump Pumps Heat Trace Temperature Control	24	0	37804-38-007 37804-38-002	F F	

Mounting Code: F - field mounted; L - line mounted; P - panel mounted
R - rack mounted; T - tank mounted; V - vendor mounted



INSTRUMENTATION INDEX

<u>TAG NUMBER</u>	<u>SERVICE/APPLICATION</u>	<u>No.</u>	<u>DATA SHEET</u>		<u>MTNG</u>	<u>NOTES</u>
			<u>Rev.</u>	<u>P&I DRAWING</u>		
FE/FQI-523, FE/FQI-525 thru FE/FQI-532	Irondale Reinjection Well Flow	25	1	37804-38-007	F	
PI-523 thru PI-532	Irondale Reinjection Well Pressure	23	0	37804-38-007	F	
PSV-301A thru PSV-305A, PSV-301B thru PSV-305B, PSV-306A, PSV-308A thru G, PSV-307A, PSV-401 & PSV-402	Dewatering Wells Pressure Safety Valve	21	0	37804-38-005	F	
PI-511 thru PI-514	Irondale System Extraction Well Pressure	26	1	37804-38-006	F	
UA-100	Irondale System Alarm Dialer	27	0	37804-38-002	F	

Mounting Code: F - field mounted; L - line mounted; P - panel mounted
 R - rack mounted; T - tank mounted; V - vendor mounted



DATA SHEET NO. 1

TAG NUMBER: FE/FQI-301 Thru 307 & FE/FQI 401, 402 (Total 9 req'd)
MANUFACTURER: Neptune
MODEL NUMBER: T-10-2"

SERVICE: Dewatering Wells Flow

METER TYPE

Type	Turbine
Size	1-1/2"
End Connections	1-1/2" NPT, Oval Bronze Flange
Materials of Construction	Cast Bronze
Pressure Rating	150 PSI

METER HEAD

Type Mounting	In line
Propeller Support Materials	MFG Standard
Type Drive	Magnetic
Propeller Material	Stainless Steel
Number of Digits (Totalizer)	6
Type Indicator	Sweep Hand - 100 Gallons/REV
Minimum and Maximum Flow Range	4 to 150 GPM
Accuracy	± 1.5%

SERVICE CONDITIONS

Fluid	Groundwater
Normal Flow	70 GPM
Normal Pressure	70 PSIG
Normal Temperature	55°F
Specific Gravity	1.0
% Solids and Type	None



DATA SHEET NO. 2A

TAG NUMBER: FE-103 (Total 1 req'd)
 MANUFACTURER: Dieterich Standard
 MODEL NUMBER: DCR-25-6" SCH 80 PVC, HA2, CA2S, MR4 (Note 1)

SERVICE: Bag Pre-filter Raw Groundwater Flow

GENERAL

Function	Flow Control
Line Number	6" RGW-PVC
Material of Line	Sch 80 PVC
Line Size	6 inch

ELEMENT

Type	Pitot
Material	Stainless Steel
Rating	150# ANSI
Process Connection	Saddle
Accuracy	±1%
Location	Horizontal
Instrument Connection	½" NPT

SERVICE CONDITIONS

Fluid	Groundwater
Normal Flow	700 GPM
Normal Pressure	70 PSIG
Normal Temperature	55°F
Specific Gravity	1.0
% Solids and Type	None

NOTES

1. Furnish saddle mount clamp and neoprene gasket model NF4.



DATA SHEET NO. 2B

TAG NUMBER: FT-103 (Total 1 req'd)
MANUFACTURER: Dieterich Standard
MODEL NUMBER: 1151DP SQ RT-4-J-12-B2D1MI-

SERVICE: Bag Pre-Filter Raw Groundwater Flow

TRANSMITTER

Type (Force Bal.: Motion)	Differential Pressure Square Root
Body Material	Cad Plated Carbon Steel
Wetted Parts Material	316 SS
Span	Adjustable
Supply (Volts; PSI; etc.)	24 VDC
Output	4-20 Ma
Process Connection Size	1/2" NPT
Type Mounting	Surface Bracket
Range	0-25/150 IN H ₂ O

ACCESSORIES

Output Indicator	0-100% Linear
Air Supply Regulator	---
Pressure Seal Units	---
Valve Manifold	3 Valve, Stainless Steel

SERVICE CONDITIONS

Ambient Temperature Range	40°F to 100°F
Location (Outside; Inside)	Inside
Process Fluid	Groundwater
Process Fluid Temp & Pressure	55°F/70 PSIG
Atmos. (Hazardous; Non-Haz.)	Non-Hazardous



DATA SHEET NO. 3

TAG NUMBER: LE/LSL/LSH/LSHH-201 (Total 1 req'd)
MANUFACTURER: Drexelbrook
MODEL NUMBER: 506-4000-1

SERVICE: Raw Ground Water Influent Sump Well

ELECTRONIC UNIT (POINT LEVEL CONT.)

Type Housing and Rating	NEMA Type 4
Type Mounting	Surface
Maximum Operating Temperature	100°F
Power Input	120 VAC, 60 Hz
Output Contacts Form and Rating	(4) DPDT, 3 AMP Inductive
Adjustment Range	4 - 20 ft
Differential for Dead Band	
Adj. Range	0 - 100 % of full span
Time Delay (On; Off; On and Off)	Not Required
Material Buildup on Probe Comp.	None

PROBE

Type	TFE Covered Metal Rod
Gain (High; Medium; Low)	Mfg. Standard
Mounting (Remote; Integral)	Remote
Type and Size Mounting Thread	2 inch 150# RF C.S. Flange
Cable Length (Remote Type)	100 ft
Pressure Rating	1000 PSI at 100°F
Length	10 ft
Sheath Material	TFE

SERVICE CONDITIONS

Fluid	Ground Water
Specific Gravity	1.0
Dielectric Constant	78.5 @ 25°C
Maximum Pressure and Temperature	3 PSI at 55°F
Type Measurement (Level; Interface)	Point Level
Surface (Turbulent; Clam; Froth)	Calm, Stilling Well



DATA SHEET NO. 4

TAG NUMBER: LE/LSL/LSH 301 Thru 307, LE/LSL/LSH-401, 402 (Total 9 req'd)
MANUFACTURER: Warrick Controls, Inc.
MODEL NUMBER: 2G1FOD
ELECTRODE
FITTING: Series 3E3A, Adapter Kit: 3Z1B, Electrode: 3W2, Suspension Wire: 3Z1A
SERVICE: Dewatering Well Pump Control

CONTROL UNIT

Mounting (Remote; On Probes) Remote, Starter Enclosure
Type (Single-Point; Two-Point) Differential Service
Sensitivity Range (Ohms) 5000
Power Input 120 VAC, 60 Hz
Output Contacts Form and Rating 2 N.O. & 1 N.C.
Probe Voltage and Current 10 Volt
Time Delay (On-Off; On and Off) None
Housing Electrical Rating General Purpose (Open)

PROBES

Probe Length (Minimum Level) (LSL) 120 ft (see Note 1)
Probe Length (Maximum Level) (LSH) 116 ft (see Note 1)
Probe Length (Ground) 121 ft (see Note 2)
Type Mounting 2" NPT, Cast Iron
Probe Material 303 Stainless Steel
Probe Insulation Material PVC Shield
Probe Suspension Wire No. 18, 41 Strand, PVC Insulation

SERVICE CONDITIONS

Fluid Ground Water
Temperature and Pressure 55°F
Type Measurement (interface; Level) Level Control
Ambient Temperature -40 to 110°F
Type Atmosphere Outside/Down Well

NOTES

1. Field to determine exact length for pump "On", and pump "Off".
2. Ground probe shall extend approximately 1'-0" below low level probe.



DATA SHEET NO. 5

TAG NUMBER: FV-103 (Total 1 req'd)
 MANUFACTURER: KEYSTONE VALVE
 MODEL NUMBER: EPI 13-121-952-270-777-002 (1 pair extra limit switches)
 VALCOM: 1620-120-1
 SERVICE: Bag Pre-Filter Raw Groundwater Flow Control Valve

VALVE

Size 6"
 Type (Butterfly; Ball; Plug) Butterfly
 Type End. Conn. and Pressure Rating 150# ANSI FF flange
 Body Material Cast Iron
 Trim Material Stainless steel
 Liner or Seal Material EPDM
 Type Packing and Material TFE seal
 Characteristic (Equal %; Linear) Equal Percentage

ACTUATOR

Type (Pneu.; Elect.; Hydraulic) Electrical
 Supply (psi; V ac; V dc) 115 V ac, 60 Hz
 Type Control (Throttling; On-Off) Throttling
 Travel Limit Settings 100% open and 20% close
 Classification (Area) Unclassified
 Type Housing NEMA 4
 Fail Position Closed (see note 1)

POSITION

Mounting (On Valve; Remote) On valve
 Supply (psi; V ac; V dc) 24VDC from Controller
 Input (psi; mA) 4-20 mA dc
 Classification (Area) General Purpose

ACCESSORIES

Hand Wheel/Location Yes/Side
 Solenoid Bleed on Actuator No
 Travel Limits/Set at 20% open/90% closed
 Mech Stops set at 0° closed/90° open
 Air Supply Regulator None
 Heater/Thermostat Required in actuator

SERVICE CONDITIONS

Fluid Groundwater
 Operating Temperature 55°F
 Operating Pressure 70 psig
 Normal Flow 700 gpm
 Pressure Drop (Normal Flow) 35 psig
 Cv at Normal Flow 118 gpm
 Ambient Temperature -40°F to 100°F



MORRISON KNUDSEN CORPORATION
ENVIRONMENTAL SERVICES GROUP

SPEC NO.: 38-3799
W.O. NO.: 2127-22
DATE: 11/30/90
ISSUE/REV.: 0
PAGE: 12

NOTES

1. Supply electric actuator "Fail Safe" controller with battery pack, power supply to close valve on power failure. Unit shall be NEMA 12 rated. Use Valcom battery pack rated at 1 amp unit.



DATA SHEET NO. 6

TAG NUMBER: LCV-201 (Total 1 req'd)
 MANUFACTURER: Keystone Valve
 MODEL NUMBER: EPI 36-121-952-300-777-001 (1 pair extra limit switches)
 VALCOM: 1620-120-8
 SERVICE: Influent Wet Well Level Control Valve

VALVE

Size 8"
 Type (Butterfly; Ball; Plug) Butterfly
 Type End. Conn. and Pressure Rating 150# ANSI FF Flange
 Body Material Cast Iron
 Trim Material Stainless Steel
 Liner or Seal Material EPDM
 Type Packing and Material TFE seal
 Characteristic (Equal %; Linear) Equal percentage

ACTUATOR

Type (Pneu.; Elect.; Hydraulic) Electrical
 Supply (psi; V ac; V dc) 115 VAC 60 Hz
 Type Control (Throttling; On-Off) Open, close
 Travel Limit Settings 100% open, 100% closed
 Classification (Area) NEMA 4
 Fail Position Closed (see note 1)

POSITIONER

Mounting (On Valve; Remote) None
 Supply (psi; V ac; V dc) None
 Input (psi; mA) None
 Classification (Area) None

ACCESSORIES

Hand Wheel/Location Yes/Side
 Solenoid Bleed on Actuator No
 Travel Limits 100% open, 100% closed
 Air Supply Regulator None
 Heater/Thermostat Required in actuator

SERVICE CONDITIONS

Fluid Groundwater
 Operating Temperature 55°F
 Operating Pressure 105 psi
 Normal Flow 372 gpm
 Pressure Drop (Normal Flow) 105 psi
 Cv at Normal Flow 52
 Ambient Temperature -40°F to 100°F



SPEC NO.: 38-3799
W.O. NO.: 2127-22
DATE: 11/30/90
ISSUE/REV.: 0
PAGE: 14

NOTES

1. Supply electric actuator "Fail Safe" controller with battery pack, power supply to close valve on power failure. Unit shall be NEMA 12 rated. Use Valcom battery pack rated at 8 amp unit.



DATA SHEET NO. 7

TAG NUMBER: PI 301 through PI 307, PI-401 and PI-402 (Total 9 req'd)
MANUFACTURER: ASHCROFT
MODEL NUMBER: 3½-1009-SWL-¼ LC-0-100
SERVICE: Dewatering well, transmission pipeline P&ID 37804-38-005

CASE

Size 3½
Material Stainless Steel
Mounting Stem ¼" NPT
Connection Location Lower
Window Material Polycarbonate
Color Polished
Type Ring Manufacturer's standard
Blowout Disc Location Back

DIAL

Type (Linear or Other) Linear
Figures Black on white
Range 0-100 psig
Graduations 10 major, 1 minor

ELEMENT

Type Bourdon
Material AISI 316
Range 0-100 psig
Connection Size ¼ NPT
Dampening Fluid None

MOVEMENT

Type Rack
Material Stainless steel
Span Adjustment By Linkage
Zero Adjustment By Pointer

PRESSURE SEAL

Manufacturer and Model Number None
Flange Size and Rating None
Flange Material (Process Side) None
Flange Material (Gauge Side) None
Diaphragm Material None
Fill Media None
Process Connection Size None
Capillary Length None

SERVICE CONDITIONS

Fluid Water
Normal Pressure 75 psig
Normal Temperature 55°F



DATA SHEET NO. 8

TAG NUMBER: PI-103, PI-108, PI-109, PI-201 (Total 4 req'd)
MANUFACTURER: ASHCROFT
MODEL NUMBER: 3½-1009-SW-¼LC-0-100 PSIG-XRG

SERVICE: Groundwater treatment facility transmission pipeline
pressure P&ID 37804-38-002 and 37804-38-003

CASE

Size	3½
Material	Stainless Steel
Mounting	Stem ¼" NPT
Connection Location	Lower
Window Material	Glass
Color	Polished
Type Ring	Manufacturer's standard
Blowout Disc Location	Back

DIAL

Type (Linear or Other)	Linear
Figures	Black on white
Range	0-100 psig
Graduations	10 major, 1 minor

ELEMENT

Type	Bourdon
Material	AISI 316
Range	0-100 psig
Connection Size	¼ NPT

MOVEMENT

Type	Rack
Material	Stainless steel
Span Adjustment By	Linkage
Zero Adjustment By	Pointer

PRESSURE SEAL

Manufacturer and Model Number	None
Flange Size and Rating	None
Flange Material (Process Side)	None
Flange Material (Gauge Side)	None
Diaphragm Material	None
Fill Media	None
Process Connection Size	None
Capillary Length	None

SERVICE CONDITIONS

Fluid	Water
Normal Pressure	75 psig
Normal Temperature	55°F



DATA SHEET NO. 9

TAG NUMBER: FIC-103 (Total 1 req'd)
 MANUFACTURER: Foxboro
 MODEL NUMBER: 760 CSA-2-A
 SERVICE: Bag Pre-Filter Flow Controller

CASE

Type and Size	Single 3" x 6"
Type Mounting	Shelf (existing) Note 1
Location (Panel; Local)	Panel (instr control panel)
Color	Mfg Std
Classification	General Purpose

INDICATOR

Number of Scales	2 PV & Setpoint
Scale Range or Ranges	0 - 100%

RECORDER

Size and Type
 Number of Scales and Ranges
 Speed and Motor Voltage
 Type Pen System
 Number of Pens and Colors

INPUT

Type (Volts; mV; T.C.; mA; PSI)	24 VDC, 4 - 20 Ma
Input Signal Range	4 - 20 MA
Number of Inputs	One

CONTROLLER

Output (mA; PSI; Pos. Adj.; etc.)	4 - 20 Ma DC
Supply (Vac; Vdc; PSI)	120 VAC, 60 Hz
Setpoint Scale (Full; Expanded)	Full
Modes of Control/Control Action	PI (Ratio)
Prop. Band (Standard; Wide)	Standard
Reset Time (Standard; Long)	Standard

ADDITIONAL FEATURES

Output Limiting	No
Deviation Alarm Lights	No
Bumpless Auto-Man Transfer	Yes
Transmitter Power Supply	Yes
Process Alarm Switch (High)	No
Process Alarm Switch (Low)	No
Local-Remote Transfer Switch)	Yes
Computer Set Servo	No
Separate Output Indicator	No
Integrating Totalizer	No



MORRISON KNUDSEN CORPORATION
ENVIRONMENTAL SERVICES GROUP

SPEC NO.: 38-3799
W.O. NO.: 2127-22
DATE: 11/30/90
ISSUE/REV.: 0
PAGE: 18

NOTE

1. Supply signal cable, power cable, terminal block and accessory for mounting in Foxboro 202S style shelf.



DATA SHEET NO. 10

TAG NUMBER: PSV-110(Total 1 req'd)
 MANUFACTURER: Teledyne Farris
 MODEL NUMBER: 26 KA10-120

SERVICE: Carbon Absorber Pressure Relief Valve

BODY

Base and Bonnet Material	Carbon Steel/Alloy Steel
Inlet Type, Size and Rating	Flange, 3 inch, 150# ANSI
Temperature Rating	Flange, 4 inch, 150# ANSI
Spring Material	-20 to 450
Spring Adjustment Range	Mfg. Std.

TRIM

Nozzle Material	316 Stainless Steel
Disc Material	Stainless Steel
"O" Ring Material (If Required)	-----
Guide Material	300 Series Stainless Steel
Adjustment Ring Material	Stainless Steel
Orifice Letter or Size	"K"

SERVICE CONDITIONS

Fluid	Ground Water
Set Pressure	50 PSIG
Capacity Required	212 GPM
Operating Temperature	70°C
Relieving Temperature	55°C
Allowable Overpressure	10%
Molecular Weight (Vapor)	
Specific Gravity (Gas)	
Specific Gravity (Liquid)	1.0
Back Pressure (If Any)	None

ACCESSORIES

Lifting Lever	None
Gag	None



DATA SHEET NO. 11

TAG NUMBER: FE/FQI-108 (Total 1 req'd)
 MANUFACTURER: McCrometer
 MODEL NUMBER: MF-100

SERVICE: Treatment Plant Transmission Pipeline Flow

METER TYPE

Type	Turbine
Size	8"
End Connections	8" FF Flange, 150# ANSI
Materials of Construction	Carbon Steel, Epoxy Coated
Pressure Rating	150 PSI

METER HEAD

Type Mounting	In Line
Propeller Support Materials	Stainless Steel
Type Drive	Magnetic Coupled
Propeller Material	High-Impact Plastic
Number of Digits (Totalizer)	6
Type Indicator	Flow Rate, 0-1500 GPM
Minimum and Maximum Flow Range	100/1500
Accuracy	± 2% of full range

SERVICE CONDITIONS

Fluid	Groundwater
Normal Flow	700 GPM
Normal Pressure	8 PSIG
Normal Temperature	55°F
Specific Gravity	1.0
% Solids and Type	None



DATA SHEET NO. 12

TAG NUMBER: FE/FQI-201 (Total 1 req'd)
MANUFACTURER: Neptune
MODEL NUMBER: 90237-001

SERVICE: Dewatering Wells Transmission Pipeline Flow

METER TYPE

Type	Turbine
Size	6"
End Connections	6" FF Flange, 150# ANSI
Materials of Construction	Cast Bronze
Pressure Rating	150 PSI

METER HEAD

Type Mounting	In Line
Propeller Support Materials	MFG Standard
Type Drive	Magnetic
Propeller Material	MFG Standard
Number of Digits (Totalizer)	6
Type Indicator	Sweep Hand - 1000 Gallons
Minimum and Maximum Flow Range	20 to 2000 GPM
Accuracy	± 1.5%

SERVICE CONDITIONS

Fluid	Groundwater
Normal Flow	352 GPM
Normal Pressure	105 PSIG
Normal Temperature	55°F
Specific Gravity	1.0
% Solids and Type	None



DATA SHEET NO. 13

TAG NUMBER: FV-202 (Total 1 req'd)
MANUFACTURER: Keystone
MODEL NUMBER:

SERVICE: Influent Wet Well Flow Valve

VALVE

Type	Butterfly
Size	4"
Type End Conn. and Pressure Rating	150# ANSI FF Flange
Body Material	Cast Iron
Trim Material	Stainless Steel
Liner or Seal Material	EPDM
Type Packing and Material	TFE Seal
Characteristic (Equal %; Linear)	Equal Percentage

ACTUATOR

Type	Gear with Chain Wheel Operator & 10 ft. of Chain
------	--

SERVICE CONDITIONS

Fluid	Groundwater
Operating Temperature	55°F
Operating Pressure	105 PSI
Normal Flow	372 GPM
Pressure Drop (Normal Flow)	105 PSI
Cv at Normal Flow	36
Cv when 20% Open	≤100
Cv when 90°	≥550
Ambient Temperature	40°F to 100°F



DATA SHEET NO. 14

TAG NUMBER: PSV-108A & PSV-108B (Total 2 req'd)
MANUFACTURER: Valve and Primer Corp (APCO)
MODEL NUMBER: 50

SERVICE: Post Bag Filter Pressure Safety Valve

BODY

Size 3/4 inch
Inlet Type 3/4 NPT
Material Cast Iron

TRIM

Float Material Stainless Steel
Seat Material Brass/Stainless Steel
Orifice Size 3/32 inch

ACCESSORIES

Isolation Valve None

SERVICE CONDITIONS

Fluid Ground Water
Maximum Flow H₂O/Air 1000 GPM/5 CFM
Flowing Temperature 55°F
Operating Pressure Range 2 to 110 PSIG

REMARKS



DATA SHEET NO. 15

TAG NUMBER: PSV-511 thru PSV-514 (Total 4 req'd)
MANUFACTURER: Valve and Primer Corp (APCO)
MODEL NUMBER: 50

SERVICE: Irondale System Extraction Well Pressure Safety Valve

BODY

Size 3/4 inch
Inlet Type 3/4 NPT
Material Cast Iron

TRIM

Float Material Stainless Steel
Seat Material Brass/Stainless Steel
Orifice Size 3/32 inch

ACCESSORIES

Isolation Valve None

SERVICE CONDITIONS

Fluid Ground Water
Maximum Flow H₂O/Air 1000 GPM/5 CFM
Flowing Temperature 55°F
Operating Pressure Range 2 to 110 PSIG



DATA SHEET NO. 16

TAG NUMBER: FE/FQI-511 Thru 514 (Total 4 req'd)
MANUFACTURER: Neptune
MODEL NUMBER: T-10-2"

SERVICE: Irondale System Extraction Well Effluent Flow

METER TYPE

Type	Turbine
Size	2"
End Connections	2" NPT Oval Bronze Flange
Materials of Construction	Cast Bronze
Pressure Rating	150 PSI

METER HEAD

Type Mounting	In Line
Propeller Support Materials	MFG Standard
Type Drive	Magnetic
Propeller Material	Stainless Steel
Number of Digits (Totalizer)	6
Type Indicator	Sweep Hand - 100 Gal/Revolution
Minimum and Maximum Flow Range	3 to 200 GPM
Accuracy	± 1.5%

SERVICE CONDITIONS

Fluid	Groundwater
Normal Flow	120 GPM
Normal Pressure	53 PSIG
Normal Temperature	55°F
Specific Gravity	1.0
% Solids and Type	None



DATA SHEET NO. 17

TAG NUMBER: LE/LSL/LSH-511 Thru 514 (Total 4 req'd)
 MANUFACTURER: Warrick Controls, Inc.
 MODEL NUMBER: 2G1FOD, Electrode Fitting: Series 3E3A, Adapter Kit:
 3Z1B, Electrode: 3W2, Suspension Wire: 3Z1A

SERVICE: Irondale Dewatering Well Pump Control

CONTROL UNIT

Mounting (Remote; On Probes)	Remove, Starter Enclosure
Type (Single-Point; Two-Point)	Differential Service
Sensitivity Range (Ohms)	5000
Power Input	120 VAC 60 Hz
Output Contacts Form and Rating	2 N.O. and 1 N.C.
Probe Voltage and Current	10 Volt
Time Delay (On-Off; On and Off)	None
Housing Electrical Rating	General Purpose (Open)

PROBES

Probe Length (Minimum Level) (LSL)	90 ft (see Note 1)
Probe Length (Maximum Level) (LSH)	86 ft (see Note 1)
Probe Length (Ground)	91 ft (see Note 2)
Type Mounting	2" NPT, Cast Iron
Probe Material	303 Stainless Steel
Probe Insulation Material	PVC Shield
Probe Suspension Wire	No. 18, 41 Strand, PVC Insulation

SERVICE CONDITIONS

Fluid	Ground Water
Temperature and Pressure	55°F
Type Measurement (interface; Level)	Level Control
Ambient Temperature	-40 to 110°F
Type Atmosphere	Outside/Down Well

NOTES

1. Field to determine exact length for pump "On" and pump "Off".
2. Ground probe shall extend approximately 1'-0" below low level probe.



DATA SHEET NO. 18

TAG NUMBER: TC-511 Thru TC-514 (Total 4 req'd)
 MANUFACTURER: United Electric
 MODEL NUMBER: 103 Stock No. 9201

SERVICE: Irondale System Extraction Well Heat Tracing
 Temperature Control

ELEMENT

Type (Bi-Metal; Filled): Filled
 Stem Diameter & Material (Bi-Metal): 9/16"/Brass
 Stem Connection: 3/8" NPT
 Bulb Diameter and Material: None
 Bulb Connection Size and Type: None
 Insertion Length "U": 2-1/8"
 Lagging Ext. Length "T": -----
 Overall Length "L": -----
 Capillary Length and Material: -----
 Range: 0-225°F

WELL

Type (Built-up; Bored; Heavy Duty):
 Material:
 Insertion Thread Size:
 Element Thread Size:
 Lagging Ext. Length "T":
 Overall Length "L":

SWITCH AND ENCLOSURE

Enclosure Rating: NEMA 1
 Type Switch: 1 SPDT
 Voltage and Load Rating: 125 VAC, 60 Hz/15 AMP
 Minimum Adjustment Differential: -----
 Maximum Adjustment Differential: -----
 Switch Action: Opens on high temp
 Calibration: Reference Dial

SERVICE CONDITIONS

Fluid: Ambient Air
 Normal Pressure: Atmospheric
 Normal Temperature: 50°F Set Point



DATA SHEET NO. 19

TAG NUMBER: LE/LSLL//LSL/LSH/LSHH-500 (Total 1 req'd)
 MANUFACTURER: Drexelbrook DE-2000F
 MODEL NUMBER: PROBE: 508-11-9
 CONTROLLER: 601-2000-4
 SERVICE: Effluent Pump Level Switch

ELECTRONIC UNIT (POINT LEVEL Cont'd)

Type Housing and Rating	Nema type 4
Type Mounting	Surface
Maximum Operating Temperature	185°F
Power Input	120 VAC, 60Hz
Output Contacts From and Rating	(4) SPDT, 5 AMP @ 120 VAC
Adjustment Range	6 IN. to 20 FT.
Differential or Dead Band	
Adj. Range	0-100% of full span
Time Delay (On; Off; On and Off)	Not Required
Material Buildup on Probe Comp.	None

PROBE

Type	TFE Covered Metal Rod
Gain (High; Medium; Low)	MFG STD
Mounting (Remote; Integral)	Remote
Type and Size Mounting Thread	2 inch 150# RF C.S. Flanges
Cable Length (Remote Type)	100 FT.
Pressure Rating	1000 PSI AT 100°F
Length	13 FT. - 8 IN.
Sheath Material	TFE

SERVICE CONDITIONS

Fluid	Groundwater
Specific Gravity	1.0
Dielectric Constant	78.5 @ 25°C
Maximum Pressure and Temperature	3 PSI @ 55°F
Type Measurement (Level; Interface)	Point Level
Surface (Turbulent; Calm; Froth)	Calm, stilling well



DATA SHEET NO. 20

TAG NUMBER: FE/FQI-501 & FE/FQI-502 (Total 2 req'd)
MANUFACTURER: Neptune
MODEL NUMBER: Trident - Turbine Meter 6"

SERVICE: Irondale ReInjection Wells Flow & Irondale Recharge Well Manifold Flow

METER

Type Turbine
Size 6"
End Connections 6" 150# RF Flange
Materials of Construction Cast Bronze

METER HEAD

Type Mounting Inline
Propeller Support Materials Mfg. Std.
Type Drive Magnetic
Propeller Material Stainless Steel
Number of Digits (Totalizer) 6
Type Indicator 1000 Gal, Sweep Hand/Revolution
Minimum and Maximum Flow Range 20 to 2000 GPM
Accuracy ±1.5% of Rate

SERVICE CONDITIONS

Fluid Ground Water
Normal Flow 1000 GPM
Normal Pressure 22 PSIG
Normal Temperature 55°F
Specific Gravity 1.0
% Solids and Type None



DATA SHEET NO. 21

TAG NUMBER: PSV-301A - 305A, 301B - 305B, 306A, 307A, 308A Thru
308G, 401 & 402 (Total 21 req'd)
MANUFACTURER: Valve and Primer Corp. (APCO)
MODEL NUMBER: 50

SERVICE: Dewatering Wells Air Relief Valves

BODY

Size 3/4 inch
Inlet Type 3/4 NPT
Material Cast Iron

TRIM

Float Material Stainless Steel
Seat Material Brass/Stainless Steel
Orifice Size 3/32 inch

ACCESSORIES

Isolation Valve None

SERVICE CONDITIONS

Fluid Ground Water
Maximum Flow H₂O/Air 95 GPM/5 CFM
Flowing Temperature 55°F
Operating Pressure Range 2-110 PSIG



DATA SHEET NO. 22

TAG NUMBER: P1-501 & P1-502 (Total 2 req'd)
MANUFACTURER: Ashcroft
MODEL NUMBER: 3-1/2-1009-SW-1/4 LC-0-60-XRG

SERVICE: Irondale Reinjection Wells Pressure Irondale Recharge Well Pressure

CASE

Size 3-1/2"
Material Stainless Steel
Mounting Stem 1/4" NPT
Connection Location Lower
Window Material Glass
Color Polished
Type Ring MFG STD
Blowout Disc Location Back

DIAL

Type Linear
Figures Black on White
Range 0-60 PSIG
Graduations 10 Major, 1 Minor

ELEMENT

Type Bourdon
Material ANSI 316
Range 0-60
Connection Size 1/4" NPT

MOVEMENT

Type MFG STD
Material Stainless Steel
Span Adjustment By MFG STD
Zero Adjustment By MFG STD

PRESSURE SEAL

Manufacturer and Model No. None
Flange Size and Rating None
Flange Material (Process Side) None
Flange Material (Gauge Side) None
Diaphragm Material None
Fill Media None
Process Connection Size None
Capillary Length None

SERVICE CONDITIONS

Fluid Groundwater
Normal Pressure 22 PSIG
Normal Temperature 55°F
Pulsating or Constant Signal Constant



DATA SHEET NO. 23

TAG NUMBER: P1-523 through P1-532 (Total 10 req'd)
 MANUFACTURER: Ashcroft
 MODEL NUMBER: 3-1/2-1009-SW-1/4 LC-0-15-XRG

SERVICE: Irondale Reinjection Well Pressure

CASE

Size 3-1/2"
 Material Stainless Steel
 Mounting Stem 1/4" NPT
 Connection Location Lower
 Window Material Glass
 Color Polished
 Type Ring MFG STD
 Blowout Disc Location Back

DIAL

Type Linear
 Figures Black on White
 Range 0-15 PSIG
 Graduations 10 Major, 1 Minor

ELEMENT

Type Bourdon
 Material ANSI 316
 Range 0-15
 Connection Size 1/4" NPT

MOVEMENT

Type MFG STD
 Material Stainless Steel
 Span Adjustment By MFG STD
 Zero Adjustment By MFG STD

PRESSURE SEAL

Manufacturer and Model No. None
 Flange Size and Rating None
 Flange Material (Process Side) None
 Flange Material (Gauge Side) None
 Diaphragm Material None
 Fill Media None
 Process Connection Size None
 Capillary Length None

SERVICE CONDITIONS

Fluid Groundwater
 Normal Pressure 4 PSIG
 Normal Temperature 55°F
 Pulsating or Constant Signal Constant



DATA SHEET NO. 24

TAG NUMBER: TC-500, TC-501 & TC-502 (Total 2 req'd)
MANUFACTURER: United Electric
MODEL NUMBER: 03 Stock No. 9201

SERVICE: Irondale Reinjection Sump Piping Heat Tracing
Temperature Control

ELEMENT

Type (Bi-Metal; Filled)	Filled
Stem Diameter & Material (Bi-Metal)	9/16" Brass
Stem Connection	3/8" NPT
Bulb Diameter and Material	None
Bulb Connection Size and Type	None
Insertion Length "U"	2-1/8"
Range	0-225°F

SWITCH AND ENCLOSURE

Enclosure Rating	NEMA 1
Type Switch	1 SPDT
Voltage and Load Rating	125 VAC, 60 Hz/15 Amp
Switch Action	Opens on High Temp
Calibration	Reference Dial

SERVICE CONDITIONS

Fluid	Ambient Air
Normal Pressure	Atmospheric
Normal Temperature	50°F Set Point



DATA SHEET NO. 25

TAG NUMBER: FE/FQI-524 through FE/FQI - 532 (Total 9 req'd)
 MANUFACTURER: Neptune
 MODEL NUMBER: T-10-2"-RM

SERVICE: Reinjection Wells Flow

METER TYPE

Type	Turbine
Size	2"
End Connections	2" NPT, Oval Bronze Flange
Materials of Construction	Cast Bronze
Pressure Rating	150 PSI

METER HEAD

Type Mounting	In Line
Propeller Support Materials	MFG Standard
Type Drive	Magnetic
Propeller Material	Stainless Steel
Number of Digits (Totalizer)	6
Type Indicator	Remote Read & Local Sweep Hand,
	100 Gal/Rev
Minimum and Maximum Flow Range	3-200 GPM
Accuracy	± 1.5%

SERVICE CONDITIONS

Fluid	Groundwater
Normal Flow	100 GPM
Normal Pressure	4 PSIG
Normal Temperature	55°F
Specific Gravity	1.0
% Solids and Type	None

NOTE

1. Remote readout shall be wired with a minimum of 1 PR #16 AWG twist pair shielded. Wire by Contractor.



DATA SHEET NO. 26

TAG NUMBER: PI/511 Through PI-514 (Total 4 req'd)
MANUFACTURER: Ashcroft
MODEL NUMBER: 3½-1009-SWL-¼ LC-0-60
SERVICE: Irondale System Extraction Well Pressure

CASE

Size 3½
Material Stainless Steel
Mounting Stem ¼" NPT
Connection Location Lower
Window Material Polycarbonate
Color Polished
Type Ring Manufacturer's Standard
Blowout Disc Location Back

DIAL

Type (Linear or Other) Linear
Figures Black on White
Range 0-60 PSIG
Graduations 10 major, 1 minor

ELEMENT

Type Bourdon
Material AISI 316
Range 0-60 PSIG
Connection Size ¼ NPT
Damping Fluid Glycerine

MOVEMENT

Type Rack
Material Stainless Steel
Span Adjustment By Linkage
Zero Adjustment By Pointer

PRESSURE SEAL

Manufacturer and Model Number None
Flange Size and Rating None
Flange Materials (Process Side) None
Flange Material (Gauge Side) None
Diaphragm Material None
Fill Media None
Process Connection Size None
Capillary Length None

SERVICE CONDITIONS

Fluid Water
Normal Pressure 55 PSIG
Normal Temperature 55°F
Pulsating or Constant Signal Constant



DATA SHEET NO. 27

TAG NUMBER: UA-100 (Total 1 req'd)
 MANUFACTURER: Kaye Instruments
 MODEL NUMBER: ADAS Dialog #8CH x 7300
 SERVICE: Irondale Alarm Dialer

GENERAL

Type (Visual; Audible; Both)	Both
Case Color and Mounting	Blue/Wall
Code Classification	Phone Alarm
Power Source Voltage	110 VAC
Signal Contact Voltage	Manufacture Standard
Contact Pos. for Alarm	Selectable
Type Acknowledge/Reset/Test	Answer/Pushbutton/Call-in
Ack., Test and Reset Location	Local and Remote
Flasher Location	Local
Type Relays	None

SEQUENCE

Normal	Run - LED
Abnormal	LED's and Voice Message over Phone
Acknowledge	Answer of Phone
Condition Returns to Normal	Normal Status
Reset	Pushbutton or Answer
Test	Call In

DISPLAY

Type	LED
Color: Letters/Background	White on Blue
Number of Points	4-8 Points

ACCESSORIES

Ack., Reset and Test Pushbuttons	Clear Pushbutton
Horn	Speaker
Spare Light Bulbs	None
Spare Flasher	None

NAMEPLATE LEGEND

1. Alarm 1
2. Alarm 2
3. Alarm 3
4. Alarm 4
5. Alarm 5
6. Alarm 6
7. Alarm 7
8. Alarm 8
9. Run/Bypass
10. Phone Fault
11. Ringing
12. Off Hook
13. Low Battery