

EW-2-82

January 1982

A TREATISE ON EXERGY AND THE  
SECOND LAW OF THERMODYNAMICS

by

V. J. LOPARDO  
Professor

Mechanical Engineering Department

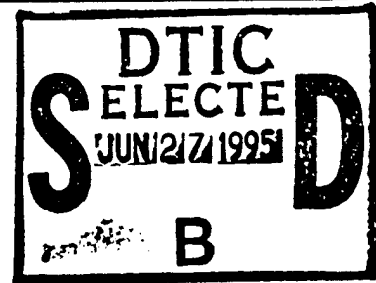
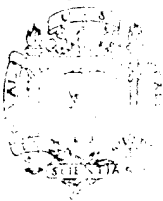

UNITED STATES NAVAL ACADEMY  
DIVISION OF  
ENGINEERING AND WEAPONS  
ANNAPOLIS, MARYLAND

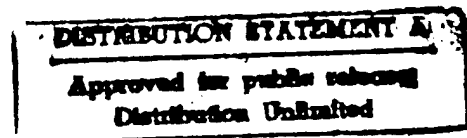

19950623 033

DTIC QUALITY INSPECTED 5

EW-2-82

January 1982

A TREATISE ON EXERGY AND THE  
SECOND LAW OF THERMODYNAMICS

by

V. J. LOPARDO  
Professor

Mechanical Engineering Department

REPORT DOCUMENTATION PAGE		READ INSTRUCTIONS BEFORE COMPLETING FORM
1. REPORT NUMBER EW-2-82	2. GOVT ACCESSION NO.	3. RECIPIENT'S CATALOG NUMBER
4. TITLE (and Subtitle) A TREATISE OF EXERGY AND THE SECOND LAW OF THERMODYNAMICS		5. TYPE OF REPORT & PERIOD COVERED January 81 - January 82
		6. PERFORMING ORG. REPORT NUMBER
7. AUTHOR(s) Professor Vincent J. Lopardo Mechanical Engineering Department		8. CONTRACT OR GRANT NUMBER(s)
9. PERFORMING ORGANIZATION NAME AND ADDRESS United States Naval Academy Annapolis, Maryland 21402		10. PROGRAM ELEMENT, PROJECT, TASK AREA & WORK UNIT NUMBERS
11. CONTROLLING OFFICE NAME AND ADDRESS		12. REPORT DATE January 1982
		13. NUMBER OF PAGES 57
14. MONITORING AGENCY NAME & ADDRESS (if different from Controlling Office)		15. SECURITY CLASS. (of this report)  UNCLASSIFIED
		15a. DECLASSIFICATION/DOWNGRADING SCHEDULE
16. DISTRIBUTION STATEMENT (of this Report)  UNLIMITED		
17. DISTRIBUTION STATEMENT (of the abstract entered in Block 20, if different from Report)		
18. SUPPLEMENTARY NOTES		
19. KEY WORDS (Continue on reverse side if necessary and identify by block number) Exergy, Second Law, Available Energy Availability, Combustion		
20. ABSTRACT (Continue on reverse side if necessary and identify by block number) The purpose of this report is to introduce the reader to the concept of exergy via the previously learned concepts of reversibility and the second law of thermodynamics. Exergy is first defined in general and then evaluated for energies of flowing streams, closed systems, heat transfer and work transfer. Some applications are given and then a review with application of combustion principles and the third law of thermodynamics follows. The paper concludes with some comments on the exergetic effectiveness of systems.		

## ACKNOWLEDGMENTS

The work for this paper has been supported in part by both the United States Naval Academy and the Naval Ship Research and Development Center, Annapolis branch. It is primarily the results of a series of seminars conducted by the author at the Catholic University of America during a sabbatical leave period from the United States Naval Academy. The constructive criticism and suggestions during these presentations by Dr. William Kelhofer, Dr. David Didion, and Dr. Enrico Sciubba is gratefully acknowledged. Section III: Combustion and The Third Law is a bi-product of an exergy analysis on gas turbine engines which was done for Mr. Rolf Muench of the Annapolis branch of Naval Ship Research and Development Center, in the summer of '81 and his support is also appreciated.

During this summer period, the many discussions with, and assistance of, Dr. Eugene L. Keating were invaluable. His critical review and suggestions on Section III added considerably to its accuracy and clarity.

Additionally, the author wishes to express his gratitude to Ms. Inez Johnson who prepared the manuscript. Without her skill and dedication to duty during the time of an extremely heavy work load, this paper could not have been completed.

<b>Accession For</b>	
NTIS GRA&I	<input checked="" type="checkbox"/>
DTIC TAB	<input type="checkbox"/>
Unannounced	<input type="checkbox"/>
Justification	
By _____	
Distribution/	
Availability Codes	
Dist	Avail and/or Special
A1	

## ABSTRACT

The purpose of this report is to introduce the reader to the concept of exergy via the previously learned concepts of reversibility and the second law of thermodynamics. Exergy is first defined in general and then evaluated for energies of flowing streams, closed systems, heat transfer and work transfer. Some applications are given and then a review with application of combustion principles and the third law of thermodynamics follows. The paper concludes with some comments on the exergetic effectiveness of systems.

## TABLE OF CONTENTS

	<u>Page</u>
ACKNOWLEDGMENTS .....	i
ABSTRACT .....	ii
TABLE OF CONTENTS .....	iii
SECTION I	
Exergy Fundamentals .....	I-1
A Question of Paths .....	I-9
Summary .....	I-11
Graphical Representation .....	I-18
SECTION II	
Combustion .....	II-1
The Third Law of Thermodynamics .....	II-8
Gibbs Function .....	II-13
Heating Value in Exergy Calculations .....	II-15
SECTION III	
Exergetic Effectiveness - Second Law Efficiencies .....	III-1
Concluding Remarks .....	III-10
SECTION IV	
Selected Bibliography .....	IV-1

SECTION I

EXERGY FUNDAMENTALS

## EXERGY FUNDAMENTALS

The first law of thermodynamics defines and limits the magnitude of energy transformations, that is, energy can be neither created nor destroyed but must be conserved. The second law of thermodynamics restricts the directions of energy transformations and the amount of useful work which can be obtained from a given amount of energy. Review, for example, the Clausius statement that "heat cannot "flow uphill" by itself" and the Kelvin Planck statement that "it is impossible to construct a cyclic engine which produces no effects except to do work and exchange heat with a single reservoir". The complete analysis of any process must include first and second law considerations. A useful concept that combines both the first and second laws is that of exergy (or available energy). This treatise will develop this concept and in the process attempt to answer the following typical questions: "What is the maximum useful work which can be done by a given amount of energy?" "What is the maximum amount of useful work which can be obtained from a heat transfer process?" and "What is the maximum amount of work which can be done by a given system during a given change of state?" These and many other questions can be resolved by understanding the exergy concept.

Our approach will be to consider observed First and Second Law phenomena and to deduce a practical set of second law equations which are analogous to the familiar first law equations. We will consider how energy changes are affected by our surroundings which for most cases will be our natural atmospheric environment existing at a temperature and pressure of  $T_0$  and  $P_0$ . Also, our analyses will generally be simplified if we use T-s and P-v diagrams along with our knowledge of reversibility which in this paper refers to total reversibility, both internal and external.

## General Observations - A New Statement

The First Law of Thermodynamics as stated for a general control volume in the absence of electrical, magnetic and surface tension effects is expressed by the following:

$$\dot{Q} - \dot{W} + \dot{m}_i (e + pv)_i - \dot{m}_e (e + pv)_e = \frac{d}{dt} [E]_{CV}$$

where

$$e = u + \frac{V^2}{2} + gz \quad \text{and } E_{CV} \text{ is } (U + \frac{mV^2}{2} + mg)_{CV}$$

The first law is not a derived law but one postulated on a number of observations. In words it says that energy is conserved i.e., the sum of the energies into a control volume whether it be via heat, work, or a flow stream minus the sum of the energies out is equal to the change in the energy of the control volume. Another observable law, generally referred to as the second law, is one that states that although energy is conserved it always tends to be degraded. That is, the quality of the energy goes down or remains the same in an isolated system. To understand the quality of energy concept, let us look at a steam turbine which exhausts to the atmosphere with an inlet line containing several expansion valves (Fig. 1).

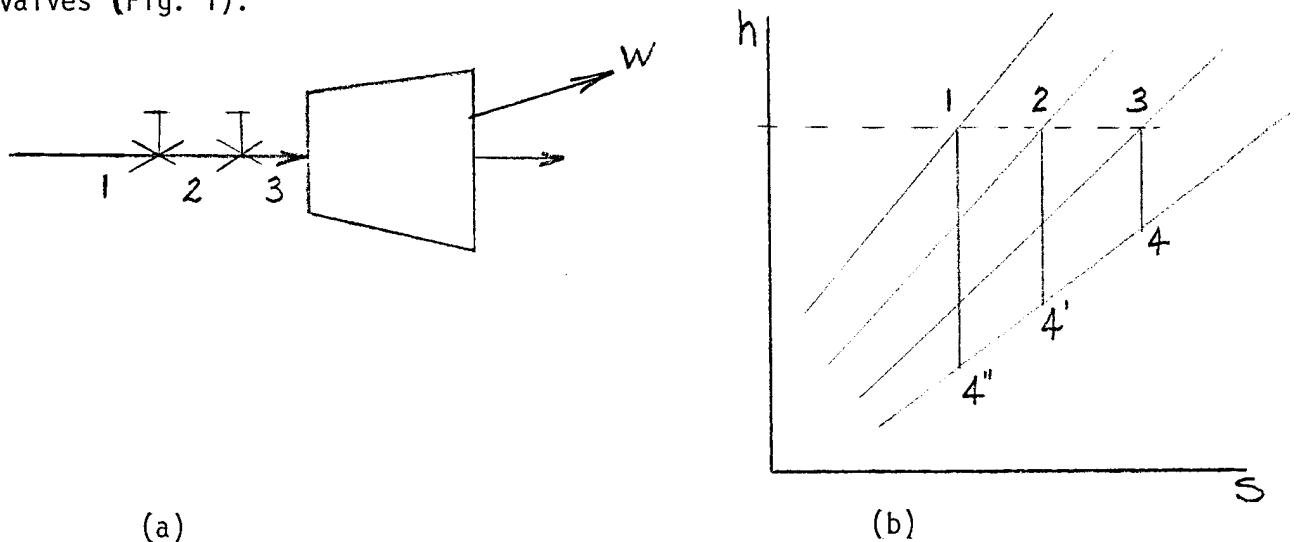

Figure 1

If we view this process on an  $h$ - $s$  diagram, Fig. 1b, we see that, neglecting change in kinetic and potential effects, the energies at 1, 2, and 3 are equal but that the work obtained (for an isentropic turbine) would be much larger in the expansion from 1-4" than 3-4. Although all points 4 are at the same exhaust pressure and  $h_1 = h_2 = h_3$  the ability to produce work was greatly reduced by the use of the throttling valves. Therefore the quality at state 1 is higher than that at 2 or 3.

From observances like this we now postulate a new form of that "law" which states "there is associated with every unit of energy in a given state a max/min amount of useful work which is directly related to its remoteness from a state of equilibrium with its environment."

This law essentially states that energy not in equilibrium with but at a higher level than its environment has the ability to produce useful work when it goes from its initial state to a state of equilibrium with the environment and that the work produced can be maximized (or, that energy at a lower level than its environment can be brought into equilibrium with its environment along a path that requires a minimum amount of work). Implicit in this concept is that in order to obtain this maximum (or minimum) work only reversible processes will be utilized. This maximum amount of work will be known as the Exergy (Ex. or ex or Ex). This is often called Availability, Available Energy, etc.

Let us now look once again at our system concept for solving problems. A boundary line or surface is drawn around the volume or mass under study and we observe the energy flows across that boundary as well as the energy changes inside the boundary. The heat transfer term, if any, is associated with a thermal reservoir and the work transfer with a work reservoir. The thermal reservoir generally consists of an infinitely large constant temperature, constant mass of disorganized energy. The fact that its

energy capacity is so large justifies the constant temperature requirement. It should be noted, however, that not all of the energy transferred from a thermal reservoir can be converted to useful work. The work reservoir or mechanical energy reservoir is conceived as a system of fixed mass which can only have work interactions with its surroundings. Energy transferred into a work reservoir is fully recoverable as work.

Exergy Transfer from a Thermal Reservoir

The question to be resolved here is "How much exergy is there in the energy transferred from a thermal reservoir? Another way of stating this question is to ask "what is the maximum work obtainable from this heat transfer?" The second law tells us that the maximum amount of work obtainable in a cyclical process must occur in a Carnot cycle which is operating between two reservoirs - in this case the thermal reservoir at  $T_R$  and the environment at  $T_0$ . The work or exergy for this energy transfer is therefore equal to  $(1 - \frac{T_0}{T_R})Q_R$  as also seen from the T-s diagram.

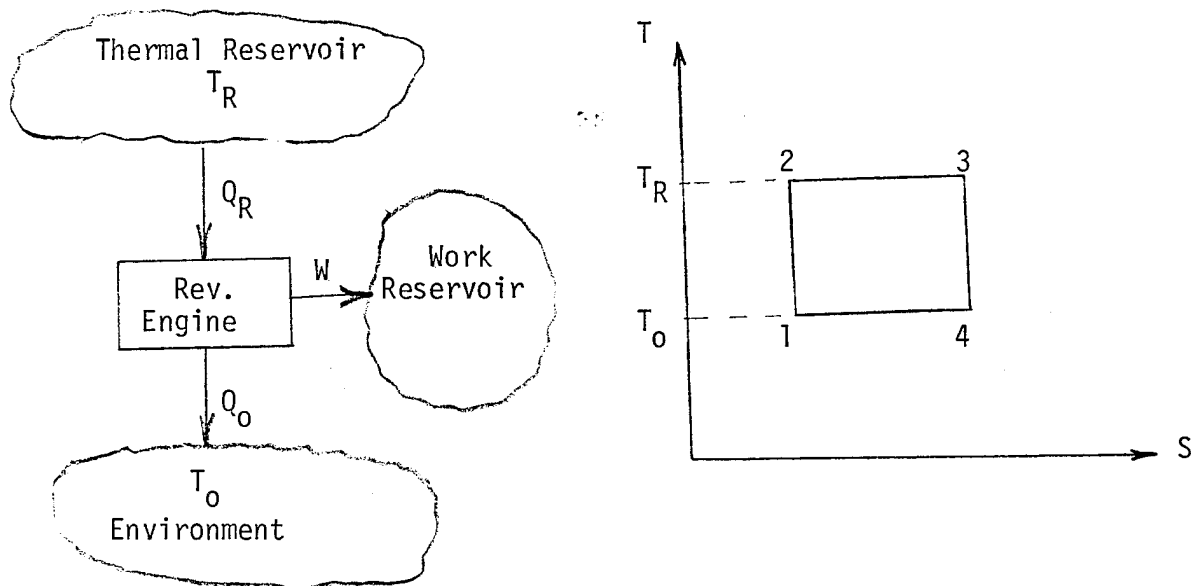

Figure 2

## Exergy Transfer from a Reservoir of Finite Size

Unfortunately not all energy transfers occur from the ideal thermal reservoir with its constant temperature capability. Many applications in engineering utilize finite thermal reservoirs with changing temperature. Since the Carnot cycle produces the maximum work when operating between two thermal reservoirs, we must now conceive of a system as shown in Fig. 3 with an infinite number of reversible engines. Each engine with heat addition at the local temperature of the reservoir and heat rejection at the temperature of the surrounding  $T_0$ .

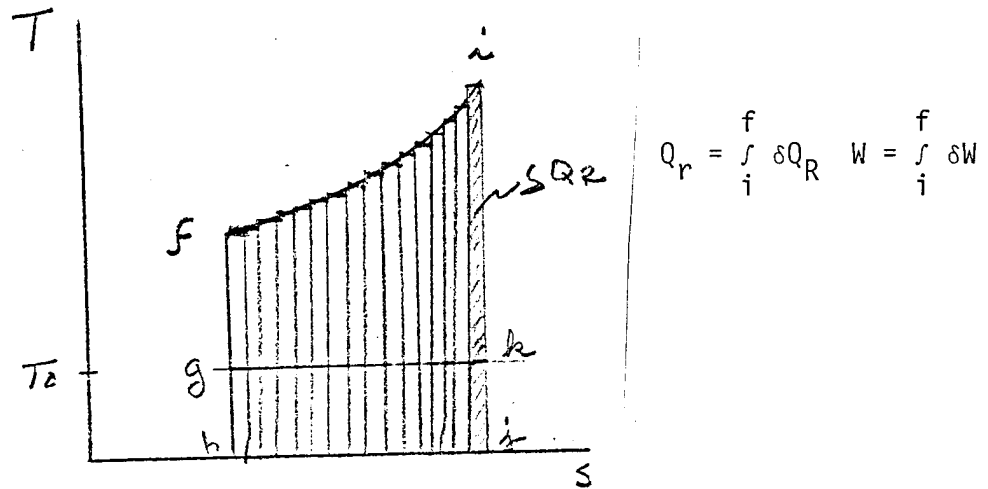

Figure 3

The heat transfer from the reservoir is the sum of the heat transfers " $\delta Q_R$ " to each of the incremental reversible engines. The work which can be produced from that heat transfer is the sum of the individual work terms " $\delta W$ ". The area i-f-h-j-i represents the total heat transfer and the area i-f-g-k-i represents the work transfer. This work transfer is the maximum which could be produced by this amount of heat transfer and is therefore the "exergy" associated with that heat transfer. The area k-g-h-j-k represents the amount of the energy transfer which can not be utilized for work and is known as the unavailable energy.

The total work or exergy therefore is  $\int_i^f \delta Q_R - T_0 \Delta_i S_f$  with  $\Delta S = \int \frac{\delta Q_R}{T_R}$

where  $Q_R$  is a function of the variable  $T_R$

$$\therefore \text{Exergy} = \int_i^f \left( \delta Q_R - \frac{(\delta Q_R)}{T_R} T_0 \right) = \int_i^f \left( 1 - \frac{T_0}{T_R} \right) \delta Q_R$$

The exergy of a flowing stream with energy of (e + pv)

The term (e + pv) is usually written as "h +  $\frac{V^2}{2}$  + gz" where h = u + pv. Once again we want to determine the maximum useful work-in this case that which can be obtained from a flowing substance with a specific energy content of "h +  $\frac{V^2}{2}$  + gz". We now make use of our knowledge of reversibility (total reversibility-both internal and external) and of the T-s diagram. For heat transfer to take place reversibly, the system and surroundings must be in thermal equilibrium, that is, just an infinitesimal temperature difference between system and surroundings during the heat transfer. Thus if the interchange is with a reservoir at constant temperature, such as the environment, then the system must undergo a reversible isothermal heat transfer process. If work interaction is to take place reversibly, it may occur in conjunction with either a reversible isothermal heat transfer process or an adiabatic process but in either case must not include any factor such as friction which would make it internally or externally irreversible.

Refer to Fig. 4. State "i" refers to the state of the substance and state "o" refers to the condition of the substance when it is in equilibrium with the environment at  $P_0$  and  $T_0$ . The reversible process joining those two is i-a-o and any work produced by this process is the maximum obtainable or the exergy of state i.

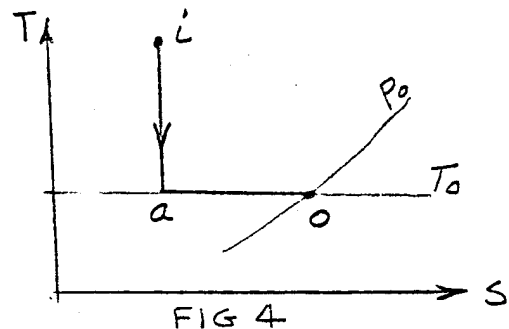

The exergy is simply obtained by writing the energy equation for that process

$$i q_0 - (i w_0)_{\text{rev}} + h_i + \frac{V_i^2}{2} + g Z_i = h_0 + \frac{V_0^2}{2} + g Z_0$$

$$i q_0 = a q_0 = T_0 (s_0 - s_i)$$

$$(i w_0)_{\text{rev}} = ex_i = h_i + \frac{V_i^2}{2} + g Z_i - h_0 - \frac{V_0^2}{2} - g Z_0 + T_0 (s_0 - s_i)$$

$$ex_i = (h_i - T_0 s_i) - (h_0 - T_0 s_0) + \frac{V_i^2 - V_0^2}{2} + g(Z_i - Z_0)$$

In general the velocity of the environment is considered to be zero and the datum for potential energy is considered to be that of the environment. With these considerations it is obvious that all of the kinetic energy and potential energy is exergy. The remaining portion and that which is normally considered for negligible kinetic and potential effect is

$$ex_i = (h_i - T_0 s_i) - (h_0 - T_0 s_0)$$

The exergy of a closed (non-flow) system with energy of  $(U + \frac{mV^2}{2} + mgz)$

As with the case of a flowing stream we will utilize our knowledge of reversibility and refer to the T-s diagram. Additionally, since the system work involves boundary work we will also use the P-v diagram. The process for maximum work as the substance follows a path to equilibrium with the environment is shown on both diagrams as 1-a-0.

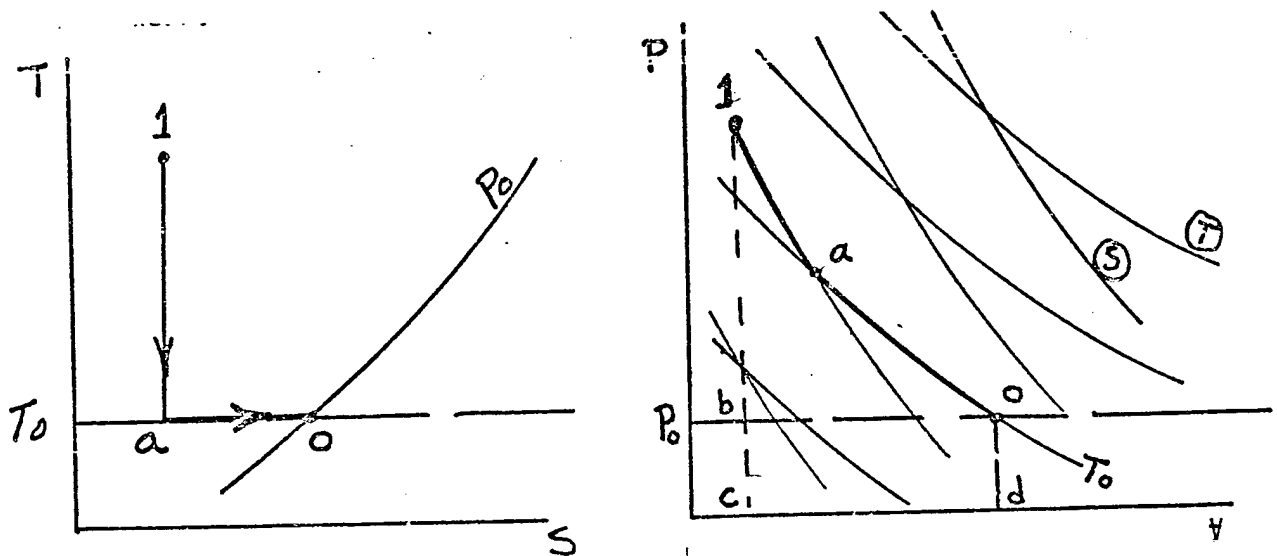

Figure 5

For process 1-0

$${}_1Q_0 - {}_1W_0 = U_0 - U_1 + m \left( \frac{V_0^2 - V_1^2}{2} \right) + mg (Z_0 - Z_1)$$

$${}_1Q_0 = T_0(S_0 - S_a) = T_0(S_0 - S_1)$$

$$\therefore {}_1W_0 = (U_1 - T_0S_1) - (U_0 - T_0S_0) + \frac{mV_1^2}{2} + mg Z_1$$

for zero kinetic and potential effects in the environment. However our definition for exergy states maximum useful work and  ${}_1W_0$  includes work that is done on the environment which is not recoverable. The magnitude of this work is  $P_0 (V_0 - V_b) = P_0 (V_0 - V_1)$

$$\therefore Ex_1 = (U_1 - T_0S_1) - (U_0 - T_0S_0) - mP (v_0 - v_1) + \frac{mV_1^2}{2} + mg Z_1$$

### Exergy Accounting

A general exergy accounting for a control volume during a time interval  $\Delta t$  may now be written as

$$Ex_1 + \sum Ex_i (\Delta t) - \sum Ex_e \Delta t = Ex_2 + Ex_D \quad \text{or}$$

$$\sum Ex_i - \sum Ex_e = \frac{d}{dt} (Ex) + Ex_D$$

where subscripts 1 and 2 refer to times 1 and 2, i and e refer to in and exit (out), and  $Ex_D$  means "exergy destroyed, dissipated, or lost" due to irreversibilities.

However, the value of exergy accounting is not with the unsteady cases of those of short time periods. Most systems which will lend themselves to exergy evaluations are either steady flow or closed (non flow) and their exergy accounting equations follow:

For steady flow processes

$$\sum Ex_{in} - \sum Ex_{out} = Ex_D$$

For closed systems or non flow processes

$$\Sigma Ex_{in} - \Sigma Ex_{out} = \Delta Ex_{sys} + Ex_D$$

A question of paths

We have seen how we defined out reversible paths for convenience but is this the only reversible path which would result in the value of exergy? We think not, because all the terms in the exergy equations are properties and are not path dependent. Therefore, let us choose another reversible path (path B) for the substance to follow in reaching equilibrium with the environment.

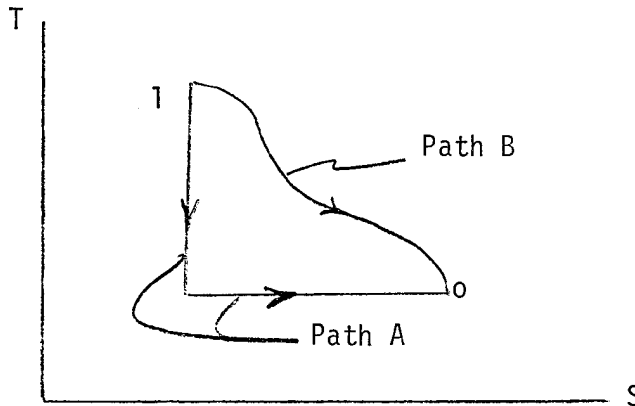

Figure 6

Neglecting kinetic and potential effects and considering the exergy of a flowing stream with energy  $(e + pv)$ , the exergy at state 1 is

$$ex_1 = (h_1 - T_0 S_1) - (h_0 - T_0 S_0) \text{ as obtained using path A ,}$$

choosing path B we write the energy and exergy equations.

$$h_1 + q = w + h_0 \tag{a}$$

$$ex_1 + ex_q = ex_w + ex_0 + ex_D \tag{b}$$

The definition for exergy states that it would be the maximum work which could be obtained from the substance as it conceivably went to an equilibrium condition with the surroundings. That value of  $w$  in equation (a) could obviously vary with the magnitude of the heat transfer. That is, with "q"

we are transferring exergy, and the magnitude of the exergy transferred is

$\int_1^0 \delta q \left(1 - \frac{T_0}{T}\right)$  or  $q - T_0 (S_0 - S_1)$ . The integral  $\int \frac{\delta q}{T}$  can be evaluated since

the process considered is reversible.

Referring to equation (b), the "ex<sub>D</sub>" is zero since this is a reversible path, the "ex<sub>0</sub>" is zero since it is our equilibrium state and the "ex<sub>w</sub>" is equal to w in equation (a). Hence.

$$h_1 + q - h_0 = ex_1 + ex_q - ex_0 + ex_D$$

substituting,

$$h_1 + q - h_0 = ex_1 + q - T_0 (S_0 - S_1) - 0 + 0$$

$$(h_1 - T_0 S_1) - (h_0 - T_0 S_0) = ex_1 \text{ as obtained previously from}$$

path A. Therefore, the exergy of a substance at a given state is always  $(h - T_0 S) - (h_0 - T_0 S_0)$  and is independent of the reversible path chosen to fulfill the requirements of our definition. However, the author feels that from a conceptual viewpoint it is best to consider reversible paths which consist of isentropic and isothermal processes.

## Summary

The exergy of a system in a given state is defined as the maximum useful work which can be obtained from the system - environment combination as the system goes from that state to a state in equilibrium with the environment while it may only exchange heat with the environment.

### Summary of Exergy Equations\*

	Energy	Exergy
Heat transfer from a Thermal Reservoir at constant $T_R$	$Q_R$	Exergy = $(1 - \frac{T_0}{T_R}) Q_R$
Heat transfer from a Thermal reservoir at varying $T_R$	$\int_i^f \delta Q_R$	Exergy = $\int_i^f (1 - \frac{T_0}{T_R}) \delta Q_R$
Work	$W$	Exergy = $W$
energy of flowing stream	$h + \frac{V^2}{2} + gZ$	Exergy = $(h - T_0 s) - (h_0 - T_0 s_0) + \frac{V^2}{2} + gz$ with zero velocity for the environment and elevation datum at the environment.
energy of closed system	$U + \frac{mV^2}{2} + mgZ$	Exergy = $(U - T_0 S) - (U_0 - T_0 S_0) - mP (v_0 - v_1) + \frac{mV^2}{2} + mgZ$ (with zero velocity for the environment and elevation datum at the environment.)

\*for negligible magnetic, electrical, and surface tension effects.

### Example Problem 1

A thermal reservoir at 500°F transfers 1500 Btu to saturated liquid water at 300 F until it becomes a saturated vapor at the same pressure. Consider the steam to be in a piston cylinder arrangement, and find the exergy lost. The environmental temperature and pressure are 70°F and 14.7 psia

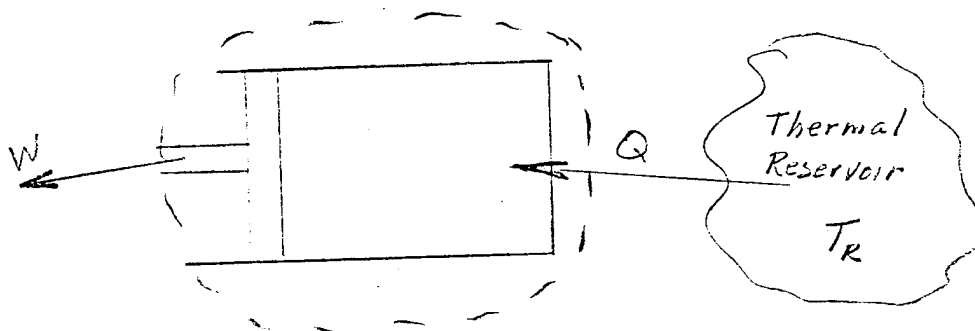

An energy balance results in  $Q - W = \Delta U$

and since  $W = \int P dV$   $Q = \Delta H = H_{fg} = m (h_{fg})$

$$1500 = m (910.4) \quad m = 1.648 \text{ lbm}$$

$$W = Q - U_{fg} = 1500 - (1.648)(830.5) = 131.65 \text{ Btu}$$

$$Ex_Q + Ex_1 = Ex_2 + Ex_W + Ex_D$$

$$Ex_Q = \left(1 - \frac{T_0}{T_R}\right) Q_R = \left(1 - \frac{530}{960}\right) 1500 = 671.9 \text{ Btu}$$

$$Ex_1 = (U_1 - T_0 S_1) - (U_0 - T_0 S_0) - m P_0 (v_0 - v_1)$$

$$Ex_2 = (U_2 - T_0 S_2) - (U_0 - T_0 S_0) - m P_0 (v_0 - v_2)$$

$$Ex_W = W = 131.65 \text{ Btu}$$

Subst.

$$671.9 + 1.648 (269.52 - 530 \times .43720) - (U_0 - T_0 S_0) - \frac{1.648 \times 14.7 \times 144}{778} \times$$

$$(.016051 - .017448) = 131.65 + 1.648 (1100.0 - 530 \times 1.6356) -$$

$$(U_0 - T_0 S_0) - \frac{1.648 \times 14.7 \times 144}{778} (.016051 - 6.472) + Ex_D$$

$$671.9 + 37.8 + .01 = 131.65 + 384.2 + 28.95 + Ex_D$$

$$\underline{\underline{164.9 \text{ Btu} = Ex_D}}$$

Example Problem 2

A steadily flowing stream obtains energy from a high temperature thermal reservoir. Neglect kinetic and potential effects and determine (a) the change in enthalpy of the stream substance and (b) the exergy destroyed in the process. The environment temperature is  $T_0$ .

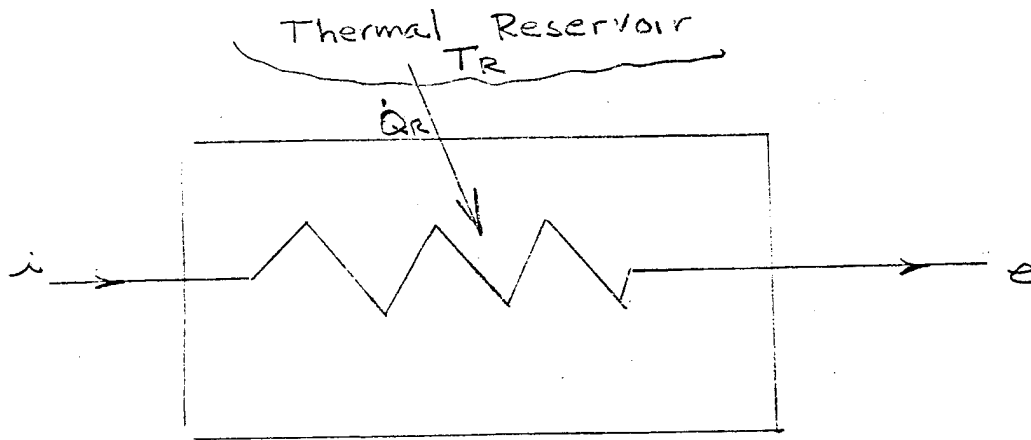

a. The energy equation is  $\dot{Q}_R + \dot{m}_i h_i = \dot{m}_e h_e$

and  $\dot{Q}_R = \dot{m} (h_e - h_i)$

b. The exergy equation is

$$\dot{E}x_Q + \dot{m} (ex_i) = \dot{m} (ex_e) + \dot{E}x_D$$

$$\dot{Q}_R \left(1 - \frac{T_0}{T_R}\right) + \dot{m} [(h_i - T_0 s_i) - (h_0 - T_0 s_0)] = \dot{m} [(h_e - T_0 s_e) - (h_0 - T_0 s_0)] + \dot{E}x_D$$

Dividing through by  $\dot{m}$

$$q_R \left(1 - \frac{T_0}{T_R}\right) + (h_i - T_0 s_i) - (h_e - T_0 s_e) = ex_D$$

units of energy per  
unit mass of flowing stream

Example Problem 3

Consider the Rankine cycle shown below and calculate the destroyed exergy of the cycle. The environmental temperature is  $530^{\circ}\text{R}$

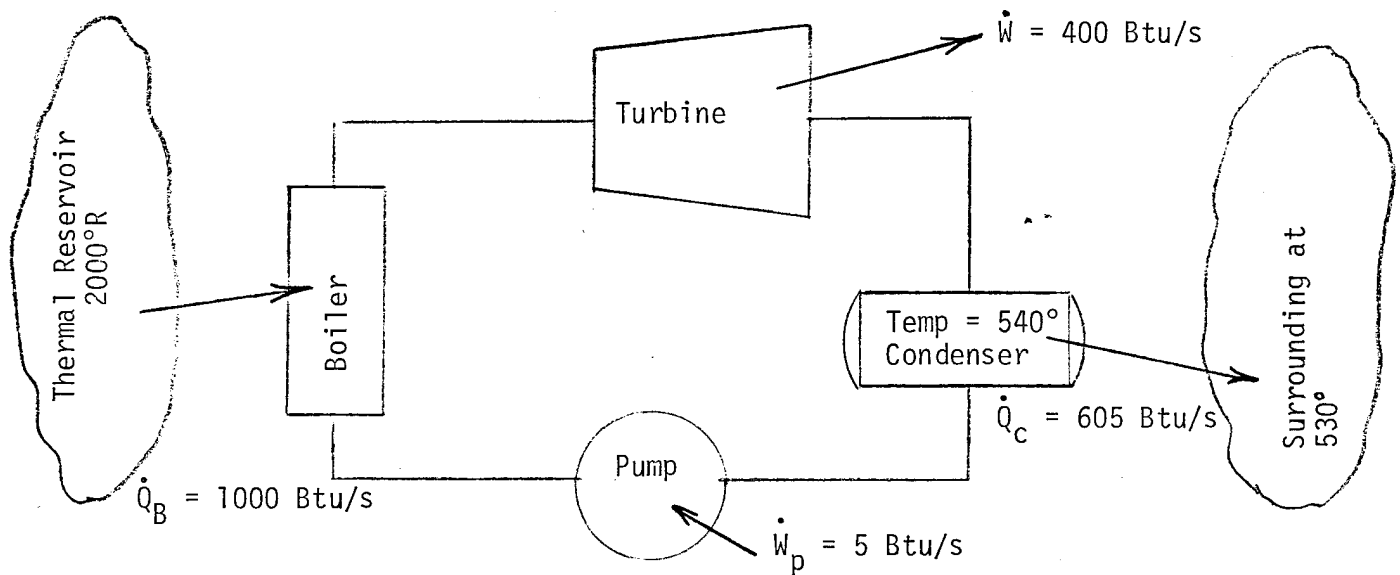

The exergy equation is

$$\dot{E}x_{Q_B} + \dot{E}x_{W_P} = \dot{E}x_{W_T} + \dot{E}x_{Q_C} + \dot{E}x_D$$

$$\left(1 - \frac{T_0}{T}\right) \dot{Q}_B + \dot{W}_P = \dot{W}_T + \left(1 - \frac{T_0}{T}\right) \dot{Q}_C + \dot{E}x_D$$

$$\left(1 - \frac{530}{2000}\right) 1000 + 5 = 400 + \left(1 - \frac{530}{540}\right) 605 + \dot{E}x_D$$

$$735 + 5 = 400 + 11.2 + \dot{E}x_D$$

$$\dot{E}x_D = 328.8 \text{ Btu/s}$$

With 740 Btu/s of exergy supplied 44.4% was destroyed or lost.

### Example Problem 4

Determine the destroyed or lost exergy of the counterflow heat exchanger shown below. The surroundings are at  $T_0$  and neglect kinetic and potential effects.

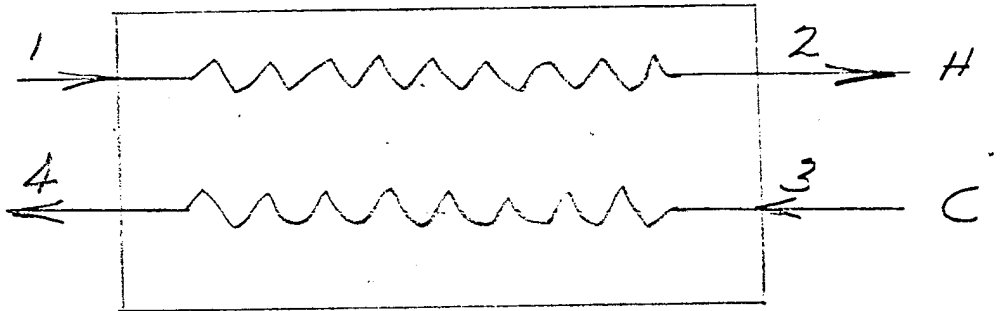

The exergy equation is

$$\dot{m}_1 ex_1 + \dot{m}_3 ex_3 = \dot{m}_2 ex_2 + \dot{m}_4 ex_4 + Ex_D$$

but

$$\dot{m}_1 = \dot{m}_2 = \dot{m}_H \quad \text{and} \quad \dot{m}_3 = \dot{m}_4 = \dot{m}_C$$

$$\dot{m}_H [(h_1 - T_0 s_1) - (h_2 - T_0 s_2)] - \dot{m}_H [(h_2 - T_0 s_2) - (h_0 - T_0 s_0)] =$$

$$\dot{m}_C [(h_4 - T_0 s_4) - (h_0 - T_0 s_0)] - \dot{m}_C [(h_3 - T_0 s_3) - (h_0 - T_0 s_0)] + Ex_D$$

From the energy equation

$$\dot{m}_H (h_1 - h_2) = \dot{m}_C (h_4 - h_3)$$

and subst; obtain

$$\dot{m}_H (T_0 s_2 - T_0 s_1) + \dot{m}_C (T_0 s_4 - T_0 s_3) = Ex_D$$

which can be written as  $T_0 \Sigma \Delta S$ .

Example Problem 5

During a specific interval of time a perfect gas rejects heat in an internally reversible constant pressure process to a large thermal reservoir at  $T_R$ . Assume that there are negligible kinetic and potential effects and that the temperature of the surroundings is  $T_0$ . Determine the exergy destroyed for systems A and B.

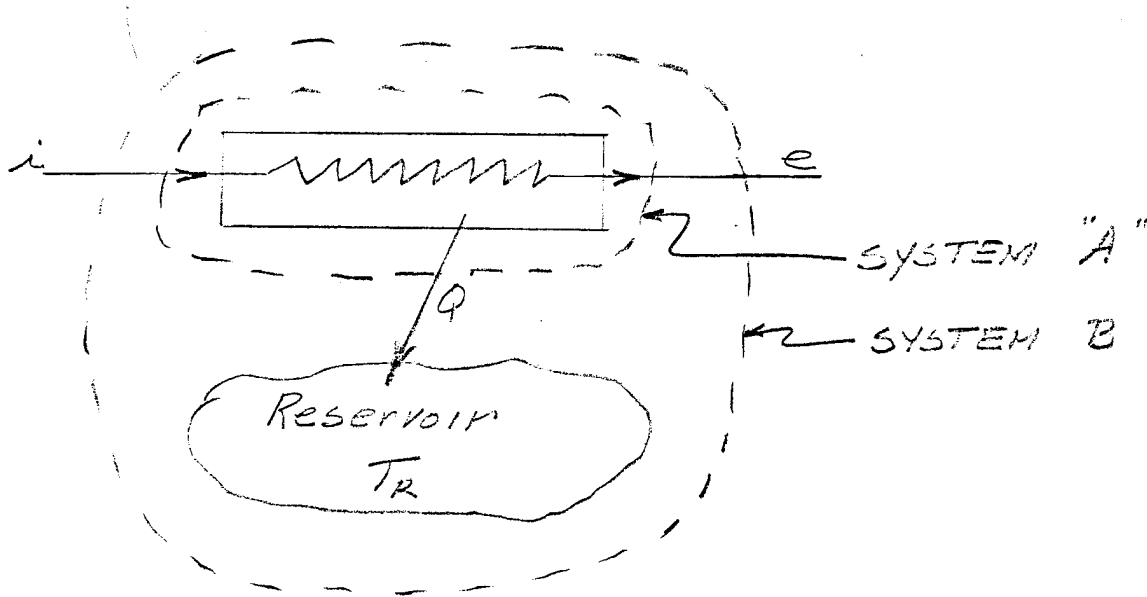

a. Let us consider system A

The energy equation is

$$\dot{Q} + \dot{m} h_i = \dot{m} h_e \quad (a)$$

$$q = h_e - h_i \quad (b)$$

The exergy equation is:

$$\dot{m} ex_i + \int_{T_i}^{T_e} \left(1 - \frac{T_0}{T}\right) \delta\dot{Q} = \dot{m} ex_e + \dot{E}x_D \quad (c)$$

$$\delta\dot{Q} = \dot{m} C_p dT \quad \text{and}$$

$$\begin{aligned} \int_{T_i}^{T_e} \left(1 - \frac{T_0}{T}\right) \delta\dot{Q} &= \int_{T_i}^{T_e} \dot{m} C_p dT - T_0 \int_{T_i}^{T_e} \frac{\dot{m} C_p dT}{T} \\ &= \dot{m} (h_e - h_i) - T_0 \dot{m} \Delta S_{i-e} \end{aligned}$$

Subst. in eq (c)

$$\dot{m} [(h_i - T_0 s_i) - (h_o - T_0 s_o) - (h_e - T_0 s_e) + (h_o - T_0 s_o)] +$$

$$\dot{m} (h_e - h_i) - \dot{m} (T_0 s_e - T_0 s_i) = \dot{Ex}_D$$

$$\therefore Ex_D = 0$$

Therefore we obtain what we should have expected - that by looking only at system A no exergy was destroyed. All of the energy leaving the heat exchanger could be directed to a series of reversible engines and could be completely utilized.

b. Now let us look at system B which includes the reservoir

$$\dot{m}_i ex_i - \dot{m}_e ex_e = \frac{d}{dt} (Ex_R) + \dot{Ex}_D \quad \text{since all properties of sub-system A are constant}$$

$$\dot{m} dt (ex_i - ex_e) = d(Ex_R) + \dot{Ex}_D dt$$

During time interval  $\Delta t$

$$Ex_i - Ex_e = \Delta Ex_R + Ex_D$$

For  $\Delta \Psi$  of Reservoir negligible

$$\Delta Ex_R = [(U_R - T_0 S_R) - (U_o - T_0 S_o)]_2 - [(U_R - T_0 S_R) - (U_o - T_0 S_o)]_1 \text{ and}$$

$$\therefore (H_i - T_0 S_i) - (H_e - T_0 S_e) = (U_R - T_0 S_R)_2 - (U_R - T_0 S_R)_1 + Ex_D$$

From the energy equation

$$\dot{m}_i h_i - \dot{m}_e h_e = \frac{d}{dt} (U)_R$$

for a given  $\Delta t$

$$H_i - H_e = (U_R)_2 - (U_R)_1$$

$\therefore$  Subst we obtain

$$- T_0 S_i + T_0 S_e = - T_0 (S_R)_2 + T_0 (S_R)_1 + Ex_D$$

$$Ex_D = T_0 (S_e - S_i) + T_0 [(S_R)_2 - (S_R)_1]$$

$$\underline{\underline{Ex_D = T_0 \Sigma \Delta S}}$$

where  $\Sigma \Delta S$  is the sum of the entropy change in the stream and the reservoir

## GRAPHICAL REPRESENTATION

At this point in the development of exergy it may be useful to see a graphical interpretation of exergy destroyed or dissipated in a heat exchanger. Consider two streams of flowing fluid in a counterflow heat exchanger. The high temperature stream loses energy as its temperature decreases from  $1_H$  to  $2_H$  and the low temperature stream gains energy as its temperature rises from  $1_L$  to  $2_L$ . The area under the process lines represent the heat transfer and are equal. That

is:  $a + b + c = b + c + d + e$ . The exergy of the energy flowing from the high temperature streams is  $a + b$  while that of the low temperature stream is  $b + d$ . The difference between the two is the exergy

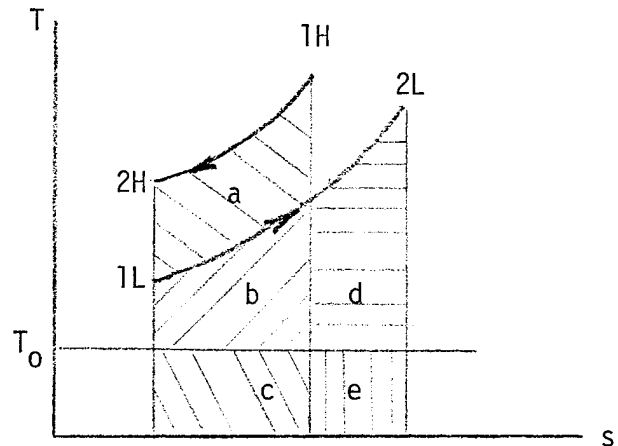

dissipated or destroyed

$$ex_D = a + b - b - d = a - d$$

Substituting for a we see that

$$ex_D = d + e - d = e$$

i.e., the area "e" is the exergy destroyed and is equal to  $T_0(S_{2L} - S_{1L}) + T_0(S_{2H} - S_{1H})$  or

$$\underline{\underline{ex_D = T_0 \Sigma \Delta S}}$$

SECTION II

COMBUSTION AND THE THIRD LAW OF THERMODYNAMICS

Many mechanical engineering analyses involve processes where the energy transfer is a result of the chemical reaction of fuels in an oxygen rich environment. The oxidation, or combustion, process is an important aspect of Thermodynamic Analysis and a brief review is in order.

### Combustion

Combustion will refer to a fairly rapid oxidation reaction, usually accompanied by a flame, which occurs due to energetics between the fuel and oxygen (usually air). The molecules of a fuel (usually a hydrocarbon  $C_xH_y$ ) have a certain amount of energy stored in the bonds between the atoms - sometimes considered as a chemical potential energy. When new compounds are formed in a chemical reaction bonds are broken and this energy is released. We must, therefore, consider this chemical potential energy when we write our energy equation for a reaction process. In most cases we do not include the chemical energy released in a process because the processes under consideration involve those of constant chemical compositions and no chemical reactions take place. For example, liquid  $H_2O$  is evaporated in a phase change to vapor  $H_2O$  but the chemical composition remains  $H_2O$ . We will now see how to evaluate the energy for reaction processes where, for example, carbon reacts with oxygen and forms a completely different product carbon dioxide ( $C + O_2 \rightarrow CO_2$ ).

### Enthalpy of Formation and Heat of Combustion

As an example, let us consider the stoichiometric combustion of methane ( $CH_4$ ) in a steady flow constant pressure process. A stoichiometric or theoretical reaction requires the complete combustion of all the combustible elements with just the right amount of air, i.e., no  $O_2$  is present in the products of combustion. The air-fuel mixture enters at  $T_1$  and the products of combustion leave at  $T_2$ . We would like to know how much heat is transferred from the process if there is no work transfer.

The reaction equation is

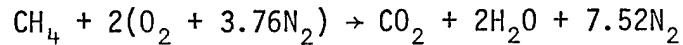

and the energy equation for negligible kinetic and potential effects is

$$\dot{Q} + \dot{H}_R = \dot{H}_P \quad , \quad \dot{Q} = \dot{H}_P - \dot{H}_R \quad \text{where the subscripts "P"}$$

and "R" refer to products and reactants. Although this is a simple equation to work with the difficulty will be to evaluate the enthalpies. Since we are not dealing with a substance of fixed chemical composition, we no longer can arbitrarily establish a value of zero enthalpy for each species which may occur and just determine the change of a property from one state to another.

The chart of the combustion of reactants and the subsequent products in a steady flow process is shown below. The actual path is from 1 to 2 as shown by the dashed line. Note that  $Q$  in the above equation is heat transfer across the system boundary and not the chemical potential energy liberated in the process.

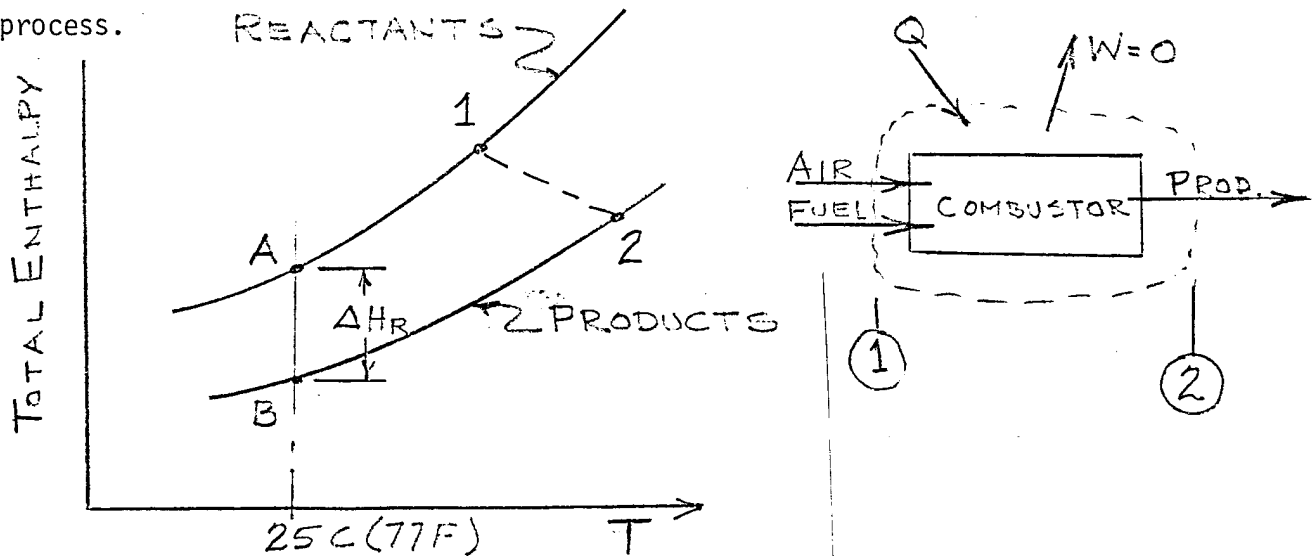

The state points 1 and 2 refer to the condition of the substances as they enter and leave a designated control volume. If the reactants had not changed composition the change in enthalpy could be determined by staying on one curve only which would have represented both reactants and products. Unfortunately, that is not the case. In order

to get around the problem of a common datum we assign a value of zero enthalpy to all elements which exist naturally at standard temperature and pressure (STP). For example  $C_s$ ,  $H_2$ ,  $O_2$ ,  $N_2$  ..... but not  $O$ ,  $N$ ,  $H$ , ..... The elements can then be combined, eg.  $C + 2H_2 \rightarrow CH_4$  and the energy required for the formation of the new compound at STP can be experimentally determined. This experimentally determined value is known as the heat of formation and is denoted by  $h_f^\circ$ . The superscript is to denote that the value was obtained at STP. For  $CH_4$ ,  $h_f^\circ = -32,179$  Btu/lbmole and correspond to point "A" on the chart. This includes the other reactants also since the enthalpy of formation for  $O_2$  and  $N_2$  are zero at STP. The value of the enthalpy at "1" then is just  $h_f^\circ$  at "A" corrected for the enthalpy difference of the reactants for a temperature difference of "A" to "1". The enthalpy of formation is negative in this case because heat was transferred out in order to keep the temperature constant (usually  $77^\circ F/25^\circ C$ ).

The magnitude of point "B" on the chart is equal to the heat of formation of the products  $CO_2$ ,  $2H_2O$ , and  $7.52N_2$ . The experimental values are (1 mole) (-169,183 Btu/mole), 2 moles (-103,968 Btu/mole) and 7.52 moles (0 Btu/mole) for a total value of -377,019 Btu or -377,019 Btu/mole of fuel. The difference between the enthalpies at "A" and "B" is called the "heat of reaction"  $\Delta H_R$ , for a reaction taking place at STP. Writing the energy equation in more detail

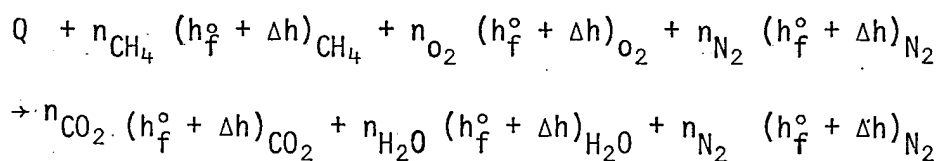

The  $\Delta h$  terms are the sensible portions from T (1 or 2) to standard T (537°R). The energy equation can also be written as

$$Q + \sum_R n_i (h_i^o) - \sum_P n_j (h_j^o) + \sum_R (n_i \Delta h_i) \rightarrow \sum_P (n_j \Delta h_j)$$

or

$$Q + n\Delta H_R + \sum_R (n_i \Delta h_i) \rightarrow \sum_P (n_j \Delta h_j)$$

The value of  $\Delta H_R$  can be obtained experimentally by the complete combustion of a fuel at standard temperature and pressure. In the case of the complete combustion of methane at STP, the first law becomes

$$Q + H_A = H_B$$

$$Q = \Delta H_R = (-377,019) - (-32,179) = -344,840 \text{ Btu/mole}$$

This is also known as the lower heating value of the fuel. The modifier "lower" is used if the  $H_2O$  is a gas and "higher" is used if the  $H_2O$  is liquid.

Going back to our original problem we see that to obtain  $H_2 - H_1$  we can evaluate  $H_1$  as  $H_A + (H_1 - H_A)$  and  $H_2$  as  $H_B + (H_2 - H_B)$  and after substituting and rearranging we obtain  $(H_B - H_A) + (H_2 - H_B)_P - (H_1 - H_A)_R$ . That is,  $\Delta H_R + (H_2 - H_B)_P - (H_1 - H_A)_R = Q$ . The values of  $H_2 - H_B$  or  $H_1 - H_A$  are determined in the usual conventional manner for a substance of fixed composition.

The quantity  $(H_1 - H_A)_R$  consists of two parts, the air and the fuel.  $(H_1 - H_A)_{air}$  can be obtained from the Gas Tables (Table No. 1) or JANAF data with  $H_1$  at the temperature of the inlet air and  $H_A$  at 537°R.  $(H_1 - H_A)_{fuel}$  can be obtained from  $C_p$  data for the fuel and represents the sensible heat change of the fuel.  $(H_2 - H_B)_P$  is obtained from tabulated data - for example Gas Tables 4 or 7 (or linear interpolation between the two tables).

However the engineer is usually faced with problems for which the data may only be 90% or 95% correct. He therefore often simplifies the solution by neglecting the  $H_A$  and  $H_B$  terms. This may be valid because most combustion processes of interest occur with excess air and the contributing factor of the nitrogen in both the inlet and exit enthalpies dominates. A comparison of the tables at 537°R will readily support this. Additionally, the fuel often enters at temperatures close to the standard temperature of 537°R and its enthalpy difference is negligible. The energy equation for an approximate solution is then written as

$$\dot{Q} - \dot{W} + \dot{m}_a h_a + \dot{m}_f (\text{LHV}) = \dot{m}_p H_p$$

where subscripts a, f, and p refer to air, fuel, and products.

#### Example Problem 1

Dodecane ( $C_{10}H_{22}$ ) is burned at constant pressure in a fuel air ratio of .0187. The inlet air is at 1173.4°R and 177.1 psia, the fuel enters at 560°R, the products of combustion leave at 2358°R. The lower heating value of the fuel is 19,020 Btu/lb and  $C_p = .535 \text{ B/lb } ^\circ\text{F} = 76.12 \text{ B/mole } ^\circ\text{F}$ . Determine the heat transfer using several methods on the order of recommended accuracy.

#### Solution:

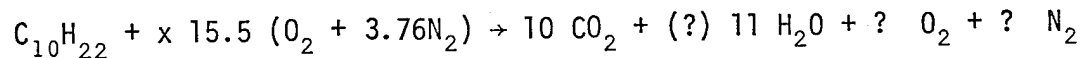

$$.0187 = \frac{(1)(142.286)}{x(15.5)(32) + x(15.5)(3.76)(38.016)}$$

$$x = 3.57$$

∴ 357° theoretical air and the combustion equation is:

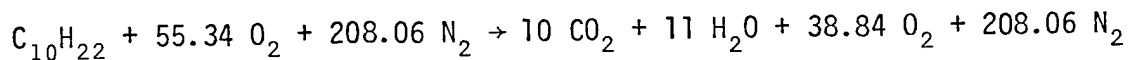

Method 1

The energy equation is:

$$Q + H_R = H_P \quad \text{or} \quad Q + \sum_R n_i (h_{f,i}^\circ + \Delta h_i^*) = \sum_P n_j (h_{f,j}^\circ + \Delta h_j)$$

H<sub>R</sub>:

$$C_{10}H_{22}: (1)[-72,875 \times 1.8001 + (76.12)(23)] = -129,432 \text{ Btu}$$

$$O_2: 55.34[0 + 4704] = +240,296 \text{ Btu}$$

$$N_2: 208.06[0 + 4506] = +937,518 \text{ Btu}$$

$$\therefore H_R = 1068381 \text{ B/mole of fuel}$$

\*Values of  $(h - h_{537})$  are available in the JANAF tables.

H<sub>P</sub>:

$$CO_2: 10[-169,297 + 21825] = -1,474,720.$$

$$H_2O: 11[-104036 + 16931] = -958,155.$$

$$O_2: 38.84[0 + 14503] = +2850422.$$

$$H_P = 980844 \text{ B/mole of fuel}$$

$$Q = H_P - H_R = -87538 \text{ B/mole} = \underline{\underline{-615 \text{ B/lb fuel}}}$$

Note that if we use the  $h_{f,i}^\circ$  values from above, the lower heating value can be obtained

$$Q + 1[-72,875 \times 1.8001] = 10[-169,297] + 11[-104036]$$

$$Q = -2706184 \text{ B/mole fuel}$$

$$= -19,019 \text{ B/lb fuel}$$

LHV = 19,019 this checks with JANAF data.

Method 2:

Writing the energy equation with the LHV term

$$Q + \text{LHV} + \Delta H_{\text{SR}} = \Delta H_{\text{SP}}$$

where subscript S refers to the sensible portion of  $\Delta H$ .

$$\begin{aligned} Q + (19,020)(142.286) + [(76.12)(23) + (55.34)(4704) + (208.06)(4506)] \\ = [(10)(21825) + (11)(16931) + (38.84)(14503) + (208.06)(13700)] \end{aligned}$$

and  $Q = -78057 \text{ B/mole fuel} = \underline{\underline{-615 \text{ B/lb}_{\text{fuel}}}}$

Method 3:

Same as method 2 except that Gas Tables are used for values

From tables

air  $h @ 1173.4^\circ\text{R} = 284.5$

$h @ 537^\circ\text{R} = 128.3$

$\Delta h = 156.2$

Products:

@357%,  $h @ 2358 = 17989 \text{ B/mole} = 621 \text{ B/lb}$

@357%,  $h @ 537 = 3753 \text{ B/mole} = 129 \text{ B/lb}$

$\Delta h = 491$

$$Q + 19,020 + \frac{156.2}{.0187} + (.535)(23) = 491 \frac{x1.0187}{.0187}$$

$$Q = \underline{\underline{-637 \text{ B/lb}_{\text{fuel}}}}$$

## The Third Law of Thermodynamics

The Third Law of Thermodynamics forms the basis for our calculations of absolute values of entropy. A formal statement of the third law is "the entropy of a pure substance in complete thermodynamic equilibrium becomes zero at the absolute zero of temperature."

For our purposes it provides an absolute base from which we can compute entropy which is required in the exergy calculations. Absolute values of entropy at 77F (25C) and 1 atm pressure are tabulated for a number of substances. Additionally, some entropies have also been tabulated for substances at temperatures other than 77F. The absolute entropy at 1 atm is usually designated as  $S^\circ$  with the temperature designated as a subscript. The entropy at a different pressure or temperature is found from  $S_{T,P} = S_T^\circ + \int_{T_0}^T \frac{\Delta S_{P/T}}{T}$  where the  $\Delta S$  term refers to the change in entropy from the tabulated value to that at the desired temperature and pressure and is calculated in our usual manner.

For example, consider the case where the entropy of  $\text{CO}_2$  is required at a temperature of 900°R and 1 atm. pressure

$$\Delta S = C_p \ln \frac{T_2}{T_1} - R \ln \frac{P_2}{P_1}$$

Assume for our purposes that  $C_p = .220 \text{ B/lb } ^\circ\text{R} = 9.682 \text{ B/lbmole } ^\circ\text{R}$

$$\begin{aligned} \Delta S &= 9.682 \ln \frac{900}{537} - R \ln \frac{1}{1} \\ &= 5.00 \end{aligned}$$

$$S = S^\circ + \Delta S = 51.072 + 5.00 = 56.07 \text{ B/lbmole } ^\circ\text{R}$$

A more accurate value of  $C_p$  for this temperature range could result in an entropy value of 56.112. These values are available in tables. If the final pressure was some value other than atmospheric the term " $-R \ln P_2/P_1$ " would have to be included with  $P_1$  being atmosphere and  $P_2$  the pressure of the substance.

## Reference State for Reactions

It now appears that the exergy of a combustion process can be found rather simply since we know how to calculate all the terms and we have established referenced states that are compatible. This is not completely true. Recall that the exergy of a system referred to the maximum work which could be obtained from that system when it went to a condition of equilibrium with the surroundings. What would that condition be for a reaction process?

We now decide that for a system which consists of substances which will react and experience a change in composition that the reference state for the reactants will be the products of a stoichiometric combustion in the form of  $\text{H}_2\text{O} (l)$ ,  $\text{CO}_2 (g)$ ,  $\text{O}_2 (g)$  etc. each pure and in their normal state at standard temperature and pressure.

### Example Problem 2

Determine the exergy of propane (g) and air at a pressure and temperature of 14.7 psia and 77°F. Consider a flow process with negligible kinetic and potential effects.

#### Solution

To find the exergy we must obtain  $(h - T_0S) - (h_0 - T_0S_0)$  where the second bracketed term refers to the products of a stoichiometric combustion with each component at STP.

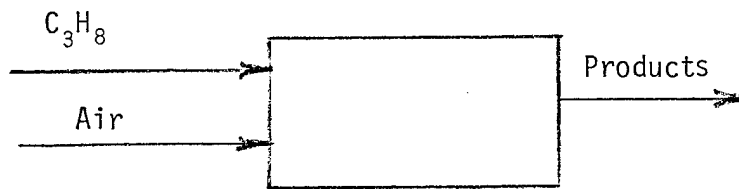

The reaction equation for 1 mole of propane is

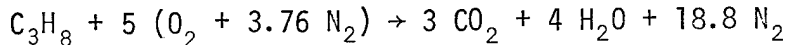

Let us tabulate the values of enthalpy and entropy which can be directly obtained from tables eg. - the JANAF tables.

		$h(\text{Btu/lbmole})$	$T_0(^{\circ}\text{R})$	$S$	$\text{Btu/lbmole } ^{\circ}\text{R}$
REACTANTS	$\text{C}_3\text{H}_8$	$- 44.676 = h_f^{\circ}$	536.7	$S^{\circ} + \Delta S$	$= 64.51 + \Delta S$
	$\text{O}_2$	$0 = h_f^{\circ}$	"	"	$= 49.004 + \Delta S$
	$\text{N}_2$	$0 = h_f^{\circ}$	"	"	$= 45.770 + \Delta S$
PRODUCTS	$\text{CO}_2$	$- 169,297 = h_f^{\circ}$	"	$S_T^{\circ}$	$= 51.072$
	$\text{H}_2\text{O}$	$- 122,971 = h_f^{\circ}$	"	$S_T^{\circ}$	$= 16.716$
	$\text{N}_2$	$0 = h_f^{\circ}$	"	$S_T^{\circ}$	$= 45.770$

To find the  $\Delta S$  values for the reactants, we assume perfect gas behavior and calculate  $\Delta S$  using a mean value of specific heat:

$$= C_p \ln \frac{T_2}{T_1} - R \ln \frac{P_2}{P_1} \quad \text{with } P_2 = \text{partial pressure and } P_1 = \text{total pressure}$$

	<u>n</u>	<u><math>n/n_T = P/P_T</math></u>	<u><math>- R \ln P/P_T \left( \frac{\text{Btu}}{1 \text{b mole } ^\circ\text{R}} \right)</math></u>	<u><math>S^0</math></u>	<u>S</u>
$\text{C}_3\text{H}_8$	1	.04032	6.38	64.51	70.89
$\text{O}_2$	5	.20161	3.18	49.004	52.18
$\text{N}_2$	18.8	.75806	0.55	45.77	46.32

The  $(h - T_0S)$  of the reactants:

$$\text{C}_3\text{H}_8: (1) [-44,676 - 536.7 (70.89)] = -82,723$$

$$5 \text{ O}_2: (5) [0 - 536.7 (52.18)] = -140,025$$

$$18.8 \text{ N}_2: 18.8 [0 - 536.7 (46.32)] = -467,367$$

The  $(h_0 - T_0S_0)$  of the products of the theoretical reaction, each at STP.

$$3 \text{ CO}_2: 3 [-169,297 - 536.7 (51.072)] = -590,122$$

$$4 \text{ H}_2\text{O}: 4 [-122,971 - 536.7 (16.716)] = -527,770$$

$$18.8 \text{ N}_2: 18.8 [0 - 536.7 (45.770)] = -461,817$$

$\therefore$  The exergy of the reactants per mole of propane is

$$\text{Ex} = \Sigma (h - T_0S) - \Sigma (h_0 - T_0S_0)$$

$$= -690,115 + 1,579,710 = 889,595 \text{ Btu/mole of propane}$$

$$= \underline{\underline{494 \text{ K cal/gm mole}}}$$

### Example Problem 3

Determine the exergy of propane (g), oxygen, and nitrogen each at a pressure and temperature of 14.7 psia and 77°F. Consider a flow process.

### Solution

This is the same problem as before except that we are letting each of the reactants exist at standard temperature and pressure. All values of "h" and "S" have been previously obtained, therefore

$h - T_0 S$  of the reactants

$$C_3H_8: (1) [-44,676 - 536.7 (64.51)] = -79,299$$

$$5 O_2: 5 [0 - 536.7 (49.004)] = -131,502$$

$$18.8 N_2: 18.8 [0 - 536.7 (45.77)] = -461,817$$

The  $(h_0 - T_0 S_0)$  of the products of the theoretical reaction, each at STP as before

$$3 CO_2: -590,122$$

$$4 H_2O: -527,770$$

$$18.8 N_2: -461,817$$

$$Ex = - 672,617 + 1,579,709 = 907,091 \text{ Btu/lbmole}$$

$$= \underline{\underline{503.7 \text{ K cal/gm mole}}}$$

## Gibbs Function

The term  $(h - TS)$  is known as the Gibbs function. The two properties  $h$  and  $S$  are evaluated at the temperature  $T$  and the Gibbs function of formation,  $G_f^\circ$  has been evaluated for various substances in the same manner as the enthalpy of formation " $h_f^\circ$ " at standard temperature and pressure. The Gibbs function at any other state can be evaluated by solving for the difference between the function at STP and the function at the desired temperature and pressure. With these tabulated values of  $G_f^\circ$ , the exergy at STP of a substance can be easily found by taking the difference between the Gibbs function of formation of the substance and the Gibbs function of formation of the stoichiometric products at STP.

$$\begin{aligned} \text{Ex } (C_x H_y O_z) &= G_f^\circ (\text{of } C_x H_y O_z) - [x G_f^\circ (\text{CO}_2 \text{ gas}) \\ &\quad + \frac{y}{2} G_f^\circ (\text{H}_2\text{O liq})] \end{aligned}$$

Note that no mention is made of  $O_2$  and  $N_2$  since the  $G_f^\circ (O_2) = G_f^\circ (N_2) = 0$  at STP.

### Example Problem 4

Find the exergy of propane at STP using the Gibbs function technique.

$$\begin{aligned} \bar{g}_f^\circ (C_3H_8) &= -10,105 \text{ B/lbmole} \\ g_f^\circ (CO_2 \text{ gas}) &= -169,677 \text{ B/lbmole} \\ g_f^\circ (H_2O \text{ liq}) &= -102,042 \end{aligned}$$

$$\begin{aligned} \text{Ex} &= -10,105 - [3 (-169,677) + 4 (-102,042)] \\ &= 907,094 \text{ Btu/lbmole} \\ &= 503.7 \text{ K cal/G mole} \end{aligned}$$

This is exactly the value obtained in the previous example and only about 2% different from the first one certainly within the range of experimental error.

### Example Problem 5

Let us now consider a reaction of methane and air which takes place adiabatically with 400 percent theoretical air. The exergy for the products which leave at a temperature of 1830R is desired.

### Solution

The combustion equation is

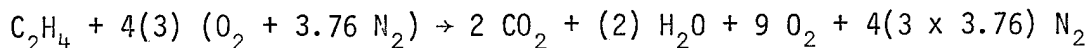

The exergy of the products is obtained by obtaining  $(h - T_0 S)_p - (h_0 - T_0 S_0)_{\text{ref. state}}$

The theoretical conversion of the products to the ref. state is:

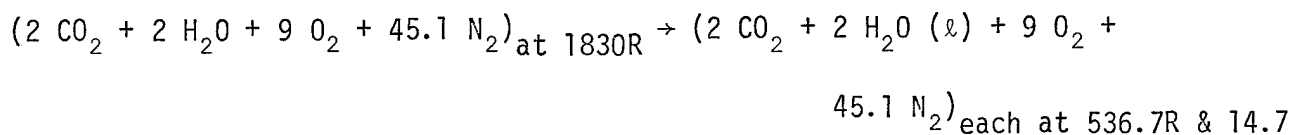

	1830°R		at 536.7	
	$h - h_0$	S	$h - h_0$	$S_0$
CO <sub>2</sub>	14,750	64.546	0	51,072
H <sub>2</sub> O	11,466	55.75	0	45,106
O <sub>2</sub>	10,012	58,321	0	49,004
N <sub>2</sub>	9,460	54.628	0	45,770

$$\begin{aligned} \text{Ex}_p &= 2 [14,750 - 536.7 (64.546) - (-536.7)(51.072)] \\ &+ 2 [11,466 - 536.7 (55.75) - (-536.7)(45.106)] \\ &+ 9 [10,012 - 536.7 (58.321) - (-536.7)(49.004)] \\ &+ 45.1 [9460 - 536.7 (54.628) - (-536.7)(45.770)] \\ &= \underline{\underline{283,899 \text{ Btu/lbmole of fuel}}} \end{aligned}$$

## Heating value in exergy calculations

Since many engineering applications are such that the lower heating value of the fuel is known, it becomes prudent to investigate its use in exergetic calculations. Consider the general case of an air-fuel mixture entering a combustion chamber at some temperature "T" with the products leaving at temperature  $T_p$ .

The following equations may be written for:

a.  $(h - T_0 S)$  of the reactants

$$n_f (h_f^\circ + \Delta h)_{fuel} + n_{O_2} (h_f^\circ + \Delta \bar{h})_{O_2} + n_{N_2} (h_f^\circ + \Delta h)_{N_2} - \quad (1)$$

$$\frac{T_f - 537}{T_a - 537} \quad \frac{T_a - 537}{T_a - 537} \quad \frac{T_a - 537}{T_a - 537}$$

$$n_f T_0 S_{fuel} - n_{O_2} T_0 S_{O_2} - n_{N_2} T_0 S_{N_2}$$

b.  $(h_0 - T_0 S_0)$  of the products at  $T_0 P_0$  with  $H_2O$  liquid

$$n_{CO_2} [(h_f^\circ + \Delta h)_{CO_2} - T_0 S_0]_{CO_2} + n_{H_2O_l} [(h_f^\circ + \Delta h) - T_0 S_0]_{H_2O} + \quad (2)$$

$$\frac{T_0 - 537}{T_0 - 537} \quad \frac{T_0 - 537}{T_0 - 537}$$

$$n_{O_2} [(h_f^\circ + \Delta h) - T_0 S_0]_{O_2} + n_{N_2} [(h_f^\circ + \Delta h) - T_0 S_0]_{N_2}$$

$$\frac{T_0 - 537}{T_0 - 537} \quad \frac{T_0 - 537}{T_0 - 537}$$

c.  $(h - T_0 S)$  of the products at  $T_p$

$$n_{CO_2} [(h_f^\circ + \Delta h) - T_0 S]_{CO_2} + n_{H_2O} [(h_f^\circ + \Delta h) - T_0 S]_{H_2O} + \quad (3)$$

$$\frac{T_p - 537}{T_p - 537} \quad \frac{T_p - 537}{T_p - 537}$$

$$n_{O_2} [(h_f^\circ + \Delta h) - T_0 S]_{O_2} + n_{N_2} [(h_f^\circ + \Delta h) - T_0 S]_{N_2}$$

$$\frac{T_p - 537}{T_p - 537} \quad \frac{T_p - 537}{T_p - 537}$$

EX REACTANTS is eqn (1) - eqn (2)

EX PRODUCTS is eqn (3) - eqn (2)

EX<sub>D</sub> is eqn (1) - eqn (3) for negligible kinetic and potential effects.

Exergy of REACTANTS =

$$n_f(h_f^\circ)_f - n_{CO_2} h_f^\circ CO_2 - n_{H_2O_{l}} h_f^\circ + n_f \Delta h_f + n_{O_2} \Delta h_{O_2} +$$

T-537                      T-537

$$n_{N_2} \Delta h_{N_2} - n_{CO_2} \Delta h_{CO_2} - n_{H_2O_{l}} \Delta h_{H_2O} - n_{O_2} \Delta h_{O_2} -$$

T-537                      T\_0-537                      T\_0-537                      T\_0-537

$$n_{N_2} \Delta h_{N_2} - T_0 [n_f S_f + n_{O_2} S_{O_2} + n_{N_2} S_{N_2} - n_{CO_2} S_{CO_2} -$$

$$n_{H_2O_{l}} S_{H_2O} - n_{O_2} S_{O_2} - n_{N_2} S_{N_2}]$$

COMBINING TERMS & IF  $T_0 = 537$  R

$$[HHV] + n_f(\Delta h_f - T_0 S)_f + n_{air} (\Delta h - T_0 S)_{air} +$$

T\_f-537                      T\_a-537

$$\Sigma n_p (T_0 S_o)_{Prod} = EX \text{ OF AIR \& FUEL } (T_0 = 537)$$

(liq.H<sub>2</sub>O)

EXERGY OF REAC. IF  $T_0 \neq 537$

$$= (HHV) + n_f(\Delta h_f - T_0 S)_f + n_{air} (\Delta h - T_0 S)_{air} - \Sigma n_p [\Delta h - T_0 S_o]_{Prod}$$

T\_f-537                      T\_a-537                      T\_0-537

where properties at  $T_0$  are for liq. H<sub>2</sub>O

EXERGY OF PRODUCTS = (Temp =  $T_p$ )

$$n_{CO_2} [h_f^\circ - h_f^\circ + \Delta h - \Delta h - T_0 S + T_0 S_o] +$$

T\_p-537    T\_0-537    T\_p

$$n_{H_2O} [h_f^\circ - h_f^\circ + \Delta h - \Delta h - T_0 S + T_0 S_o] +$$

liq T\_p-537    T\_0-537    T\_p

$$n_{O_2} [h_f^\circ - h_f^\circ + \Delta h - \Delta h - T_0 S + T_0 S_o] +$$

T\_p-537    T\_0-537    T\_p

$$n_{N_2} [h_f^\circ - h_f^\circ + \Delta h - \Delta h - T_0 S + T_0 S_o]$$

T\_p-537    T\_0-537    T\_p

EXERGY OF PRODUCTS IF  $T_o = 537$

$$= n_{H_2O} [h_f^\circ]_f^g + n_{Prod} \frac{[\Delta h - T_o (S_T - S_o)]_{Prod}}{T-537}$$

$$EX = n_{H_2O} [h_f^\circ]_f^g + \sum n_{prod} [(h - T_o S)_{T_p} - (h - T_o S_o)_{Prod}]_{T_o=537}^*$$

EXERGY OF PRODUCTS IF  $T_o \neq 537$

$$= n_{H_2O} [h_f^\circ]_f^g + \sum n_{prod} [h_{T_p} - h_{537} - h_{T_o} + h_{537} - T_o S_{T_p} + T_o S_o]$$

$$= n_{H_2O} [h_f^\circ]_f^g + \sum n_{prod} [(h_{T_p} - T_o S_{T_p}) - (h_{T_o} - T_o S_o)]^*$$

\*where properties at  $T_o$  are for liq  $H_2O$

FOR  $T_o = 537$

IF WE COMBINE TERMS AND GROUP IN A MORE CONVENIENT WAY, WE OBTAIN FOR THE EXERGY BALANCE ON A BURNER  $EX_R = EX_P + EX_D$  (CONSISTENT UNITS MUST BE CAREFULLY MAINTAINED)

$$\{HHV - n_{H_2O} [h_f^\circ]_f^g\} + n_f \frac{(\Delta h_f - T_o S)_f}{T_f-537} + n_{air} \frac{(\Delta h - T_o S)_{air}}{T_a-537}$$

$$\sum n_p (T_o S_o)_{prod} - \sum n_{prod} [(h - T_o S)_{T_p} - (h_o - T_o S_o)_{537}] = EX_D$$

$$LHV + n_f \frac{(\Delta h_f - T_o S)_f}{T_f-537} + n_{air} \frac{(\Delta h - T_o S)_{air}}{T_a-537} - \sum n_p \frac{(\Delta h - T_o S)_{T_p}}{T_p-537} = EX_D$$

In some reports the terms above are pictured as exergies related to particular streams or lines. Care must be taken in the interpretation of these values.

FOR  $T_0 \neq 537$

$$EX_D = HHV + n_f (\Delta h_f - T_0 S)_f + n_a (\Delta h - T_0 S)_{air} -$$

$$\sum n_p [\Delta h - T_0 S]_{p_0} - n_{H_2O} [h_f]_{\ell}^v - \sum n_p [(h_{T_p} - T_0 S_{T_p}) - (h_{T_0} - T_0 S_0)]$$

$$EX_D = LHV + n_f (\Delta h_f - T_0 S)_f + n_a (\Delta h - T_0 S)_a +$$

$$\sum n_p [-h_{T_0} + h_{537} + T_0 S_0 - h_{T_p} + T_0 S_{T_p} + h_{T_0} - T_0 S_0]$$

$$EX_D = LHV + n_f (\Delta h_f - T_0 S)_f + n_a (\Delta h - T_0 S)_a - \sum n_p [(\Delta h - T_0 S_{T_p})]$$

Example

For the burner shown below, calculate the exergy dissipation.

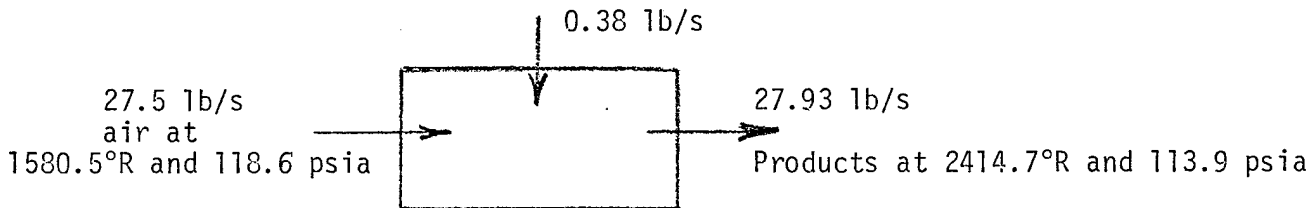

Given: LHV of fuel = 18,400 Btu/lb

Solution:

Use  $S_{fuel} \approx 0.9 \text{ B/lbm}^\circ\text{R}$  and let  $T_{fuel} = T_{537} = T_0$

$$\dot{EX}_D = \dot{m}_f (LHV) + \dot{m}_f (\Delta h_f - T_0 S)_f + \dot{m}_{air} (\Delta h - T_0 S)_{air}$$

$$- \dot{m}_p (\Delta h_p - T_0 S)_p$$

$$= (.38)(18400) + .38 (0-537 \times .9) + 27.55 [(390.0 - 128.2) - 537 \times 1.7246]$$

$$- 27.93 [(632.1 - 129.0) - 537 \times 1.8519]$$

$$\dot{EX}_D = 6992 - 184 - 18,302 + 13724$$

$$\dot{EX}_D = 2230 \text{ Btu/s}$$

SECTION III

EXERGETIC EFFECTIVENESS

## Exergetic Effectiveness - Second Law Efficiencies

The concept of efficiency is basic to the understanding of performance in mechanical engineering analysis. We are all familiar with thermal efficiency of power cycles, the coefficient of performance for refrigeration cycles and the process efficiencies for turbines, compressors and nozzles. The efficiencies of cycles are based on the first law while those for processes are related to the second law via the isentropic process. If a cycle efficiency is 40% we conclude that the plant disposes 60% of its input energy. In no way does this analysis of the efficiency tell us if the energy disposed was capable of producing any more work and if so how much. In the process equations we usually compare the actual energy transformation with that of an isentropic process between the inlet state and the outlet pressure (a fictitious exit state). However, second law enthusiasts have not been completely successful at defining a general second law efficiency either - a search of the literature will reveal that there may be as many definitions as there are authors. That this conditions abounds many not really be incriminating since all engineering problems have their own specific objectives and reasons for existing. In this paper the exergetic effectiveness of some common mechanical engineering applications will be discussed. They are presented here just to make you aware of some of the possibilities. It is left to you to decide in each particular case which, if any, of the methods are useful for your decision making process.

### Cycle Exergetic Effectiveness

The exergetic effectiveness of a cycle is defined in several ways and the first is the ratio of the net useful exergy output to the exergy input, i.e.

$$\text{Ex. Eff}_1 = \text{EE}_1 = \frac{\text{Ex}_{\text{useful output}}}{\text{Ex}_{\text{input}}}$$

For a steam power plant the net useful exergy output is the net work of the cycle. Some exergy accompanies the energy rejected but if it is not channeled to a device which can put its exergy to use it will have to be considered as destroyed or dissipated.

A second way to look at cycle exergetic effectiveness is to define it as

$$EE_2 = \frac{Ex_{out}}{Ex_{in}} = \frac{Ex_{out}}{Ex_{out} + Ex_D} = \frac{Ex_{in} - Ex_D}{Ex_{in}} = 1 - \frac{Ex_D}{Ex_{in}}$$

This definition allows us to keep some of our first law biases and still be able to evaluate exergy uses. This definition does not penalize the cycle because it may not use all of the exergy output.

Example Problem 1

Calculate the effectiveness for the Rankine cycle shown below using both definitions.

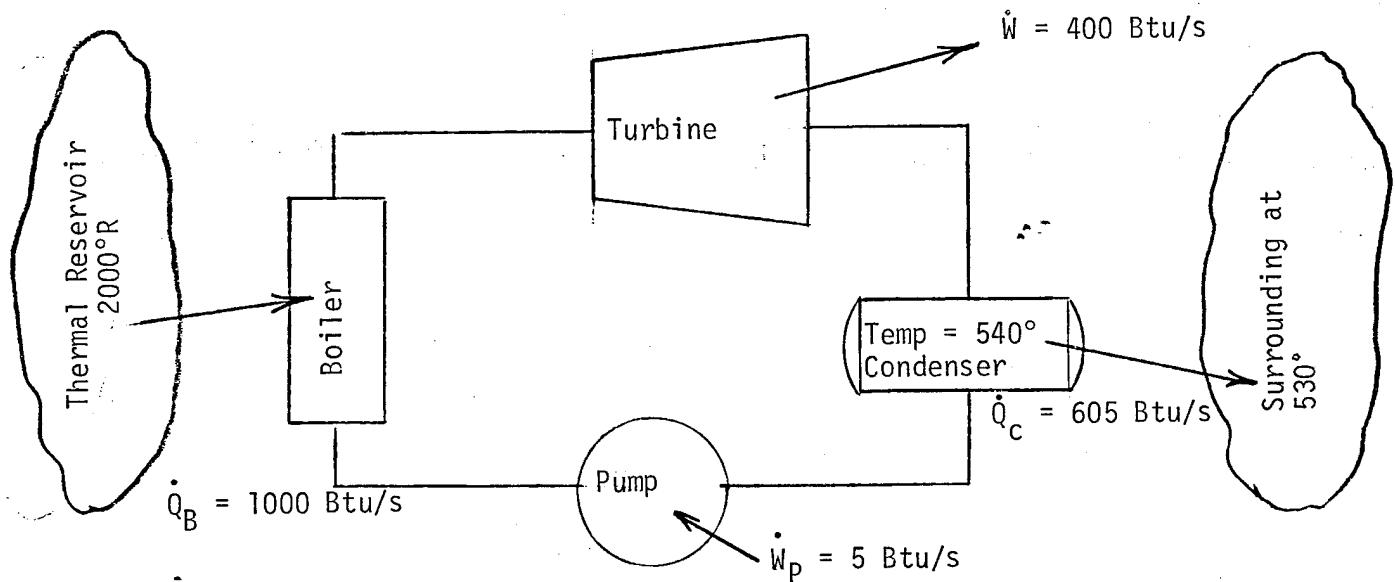

a. 
$$EE_1 = \frac{\dot{Ex}_{\text{useful output}}}{\dot{Ex}_{\text{input}}}$$

$$\dot{Ex}_{\text{input}} = Q_B (1 - T_0/T) = 1000 (1 - \frac{530}{2000}) = 735 \text{ Btu/s}$$

$$\dot{Ex}_{\text{useful output}} = 395 \text{ Btu/s}$$

$$\therefore EE_1 = \frac{395}{735} = \underline{53.7\%}$$

$$b. \quad EE_2 = \frac{\dot{E}x_{\text{output}}}{\dot{E}x_{\text{input}}}$$

$$\dot{E}x_{\text{output}} = \dot{E}x_W + \dot{E}x_C$$

$$\dot{E}x_C = Q_C \left(1 - \frac{T_0}{T_C}\right) = 605 \left(1 - \frac{530}{540}\right) = 11.20$$

$$\therefore EE_2 = \frac{395 + 11.2}{735} = \underline{\underline{55.3\%}}$$

### Process Exergetic Effectiveness (expanders)

The process exergetic effectiveness will be defined as the ratio of the useful exergy output (for an expander) to the exergy decrease. For a turbine this is the ratio of the actual work output to the work output if there had been no losses. The initial and final states of the working substance would be the actual initial and final states.

For an adiabatic turbine:

$$ex_W = h_i - h_e$$

$$ex_i = (h_i - T_0 S_i) - (h_o - T_0 S_o) \text{ and}$$

$$ex_e = (h_e - T_0 S_e) - (h_o - T_0 S_o)$$

$$\begin{aligned} \therefore EE_t &= \frac{h_i - h_e}{[(h_i - T_0 S_i) - (h_o - T_0 S_o)] - [(h_e - T_0 S_e) - (h_o - T_0 S_o)]} \\ &= \frac{h_i - h_e}{h_i - h_e + T_0 (S_e - S_i)} = \frac{W_{\text{act}}}{W_{\text{act}} + T_0 \Delta S} \end{aligned}$$

### Example Problem 2

Consider an adiabatic steam turbine which receives steam at 600 psia and 800°F and exhausts at 2 psia with a quality of 90%. The temperature of the environment is 520°R.

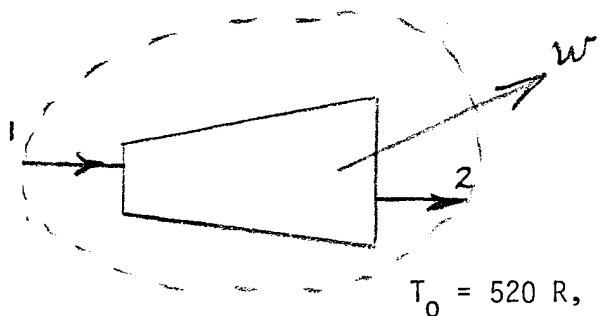

$$h_1 = 1407.6 \text{ Btu/lbm} \quad S_1 = 1.6343 \text{ Btu/lbm } ^\circ\text{R}$$

$$h_2 = 1013.9 \text{ Btu/lbm} \quad S_2 = 1.7453 \text{ Btu/lbm } ^\circ\text{R}$$

$$h_{2s} = 948.9 \text{ Btu/lbm}$$

$$T_0 = 520 \text{ R}, \quad h_0 = 28.06 \text{ Btu/lbm}, \quad S_0 = .0555 \text{ Btu/lbm } ^\circ\text{R}$$

$$\begin{aligned} \text{ex. eff} &= \frac{\text{ex}_w}{\text{ex}_{\text{dec}}} = \frac{h_1 - h_2}{(h_1 - T_0 S_1) - (h_0 - T_0 S_0) - [(h_2 - T_0 S_2) - (h_0 - T_0 S_0)]} \\ &= \frac{393.7}{(1407.6 - 1013.9) - (520)(1.6343 - 1.7453)} = 87.2\% \end{aligned}$$

Note that

1. This compares to a first law isentropic eff. of 85.83%
2. If there had been thermal losses but the same end states the numerator or desired exergy term would be diminished.

An alternate approach recommended by some is to use the same definition for the effectiveness of a process as we did for the cycle (case 2) i.e.

$$EE_2 = \frac{\text{Ex}_{\text{out}}}{\text{Ex}_{\text{in}}} = 1 - \frac{\text{Ex}_D}{\text{Ex}_{\text{in}}}$$

$$\text{ex}_{\text{in}} = \text{ex}_e + \text{ex}_w + \text{ex}_D$$

$$h_i - T_0 S_i - h_e + T_0 S_e - 393.7 = \text{ex}_D$$

$$T_0(S_e - S_i) = \text{ex}_D$$

$$520(1.7453 - 1.6343) = \text{ex}_D = \underline{57.72 \text{ Btu/lbm}}$$

$$\text{ex}_{\text{in}} = (h_i - T_0 S_i) - (h_0 - T_0 S_0) = (1407.6 - 28.06) + 520(.0555 - 1.6343)$$

$$h_0 @ 60^\circ\text{F and } 14.7 \text{ psia} = 28.06 \text{ Btu/lbm}$$

$$S_0 @ 60^\circ\text{F and } 14.7 \text{ psia} = .0555 \text{ Btu/lbm}^\circ\text{R}$$

$$\text{ex}_{\text{in}} = 1379.4 - 821 = 558.4 \text{ Btu/lbm}$$

$$\eta_{\text{ex}} = 1 - \frac{57.7}{558.4} = \underline{\underline{89.7\%}}$$

## Compression Processes

For compressors the inverse of the first process definition would be the ratio of the increase in exergy to the actual exergy transfer bringing about the increase:

$$EE_c = \frac{\text{Exergy increase}}{W_{\text{act. input}}}$$

### Example Problem 3

Consider an adiabatic air compressor in which air is compressed from a pressure of 1 bar and 22°C to 6 bars and 257°C. The environment is at a standard atmosphere of pressure and 17°C. Find the exergetic effectiveness.

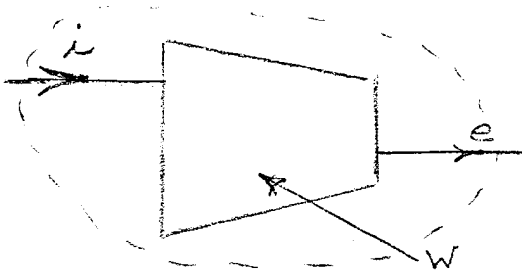

$$ex_w = h_e - h_i$$

$$ex_i = h_i - T_0 S_i - (h_0 - T_0 S_0)$$

$$ex_e = h_e - T_0 S_e - (h_0 - T_0 S_0)$$

a) From "Gas Tables" data:

$$h_i = 295.17 \text{ kJ/kg}$$

$$h_e = 533.98 \text{ kJ/kg}$$

$$S_e - S_i = 2.27967 - 1.68515 - R \ln 6/1 = .08025 \text{ kJ/kg } ^\circ\text{K}$$

$$EE_c = \frac{(h_e - h_i) - T_0 (S_e - S_i)}{(h_e - h_i)} = \frac{533.98 - 295.17 - 290(.08025)}{533.98 - 295.17} = \frac{215.54}{238.81} = \underline{\underline{90.26\%}}$$

b) Once again (as with the expander) if we use the second effectiveness definition, we obtain

$$EE_2 = \frac{ex_e}{ex_w + ex_i}$$

For this solution we must find the exergy at each of the end states with special care taken in evaluating the entropies.

$$S_e = 7.2749 - \frac{8.315}{28.97} \ln \frac{6 \times 1.013}{1} = 6.7569 \text{ kJ/kg } ^\circ\text{K}$$

$$h_e = 534.00 \text{ kJ/kg}$$

$$S_i = 6.6808 - .287 \ln \frac{1.013}{1} = 6.6771 \text{ kJ/kg } ^\circ\text{K}$$

$$h_i = 295.17 \text{ kJ/kg}$$

$$S_o = 6.6636 \text{ kJ/kg } ^\circ\text{K}$$

$$h_o = 290.17$$

$$\begin{aligned} EE_2 &= \frac{[534 - 290 (6.7569)] - [290.17 - 290 (6.6636)]}{(534 - 295.17) + [295.17 - 290 (6.6771)] - [290.17 - 290 (6.6636)]} \\ &= \frac{[-1425] - [-1642]}{(238.83) + [-1641] - [-1642]} = \frac{217}{240} = \underline{\underline{90.3\%}} \end{aligned}$$

Although the numerical values of the effectiveness are essentially the same in this example, the thought processes are entirely different.

Processes not involving work

For nozzles, diffusers, and heat exchangers, the engineer usually looks at the exergy increase and decrease in the flowing streams. The first approach is to consider the ratio of the exergy increasing streams to the exergy decreasing streams and the second considers the ratio of the exergy output to the exergy input.

Example Problem 4

Consider a heat exchanger with the inlet and exit properties as shown below and determine both types of effectiveness.

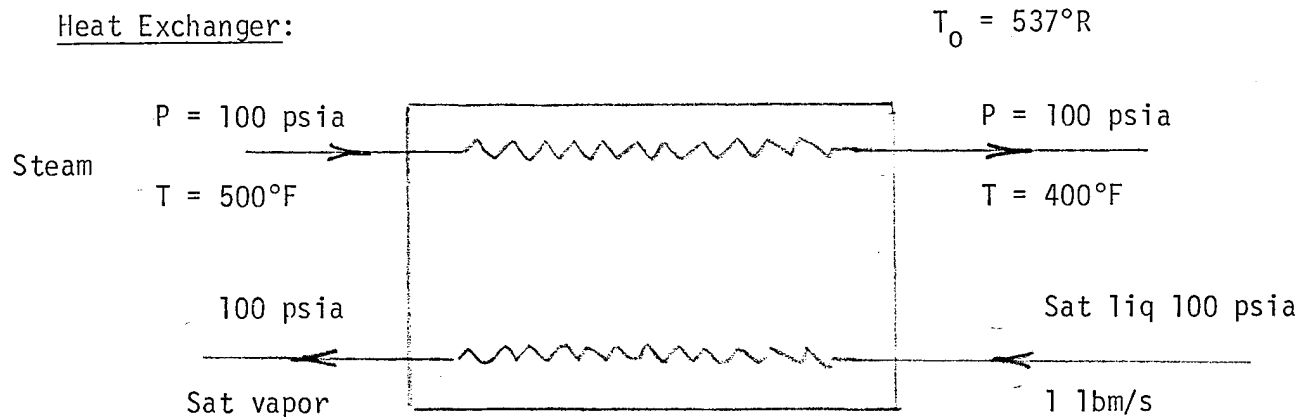

First Law

$$\dot{m}_s (h_i - h_e) = \dot{m}_w (h_e - h_i) = \dot{m}_w (h_{fg})$$

$$\dot{m}_s (1279.1 - 1227.5) = \dot{m}_w (889.2)$$

$$\dot{m}_s = \frac{889.2}{51.6} \dot{m}_w = 17.23 \dot{m}_w$$

$$\therefore \dot{m}_s = 17.23 \text{ lbm/s}$$

Second Law

$$\dot{m}_s [(h_i - T_0 S_i) - (h_o - T_0 S_o)] + \dot{m}_w [(h_i - T_0 S_i) - (h_o - T_0 S_o)] =$$

$$\dot{m}_s [(h_e - T_0 S_e) - (h_o - T_0 S_o)] + \dot{m}_w [(h_e - T_0 S_e) - (h_o - T_0 S_o)] + \dot{Ex}_D$$

$$\dot{m}_s [-T_0 S_i + T_0 S_e]_s + \dot{m}_w [-T_0 S_i + T_0 S_e]_w = \dot{Ex}_D$$

$$\dot{m}_s [T_0][S_e - S_i] + \dot{m}_w [T_0][S_e - S_i]_w = \dot{Ex}_D$$

$$[17.23][537][1.6517 - 1.7085] + [1][537][1.6034 - .4744] = \underline{97.2 \text{ Btu/s}}$$

$$\text{Effectiveness I} = \frac{\dot{E}x_{inc}}{\dot{E}x_{dec}} = \frac{\text{exergy increase streams}}{\text{exergy decrease streams}}$$

$$E_1 = \frac{\dot{m}_w \{ [(h_e - T_0 S_e) - (h_o - T_0 S_o)]_w - [(h_i - T_0 S_i) - (h_o - T_0 S_o)]_w \}}{\dot{m}_s \{ [(h_i - T_0 S_i) - (h_o - T_0 S_o)]_s - [(h_e - T_0 S_e) - (h_o - T_0 S_o)]_s \}}$$

In this case - could also be written as

$$E_1 = \frac{\dot{m}_w (ex_{inc})_w}{\dot{m}_w (ex_{inc})_w + \dot{E}x_D} = \frac{1[(h_e - T_0 S_e) - (h_o - T_0 S_o)]_w - 1[(h_i - T_0 S_i) - (h_o - T_0 S_o)]_w}{\dot{m}_w ex_{inc} + \dot{E}x_D}$$

$$E_1 = \frac{889.2 - T_0 (1.6034 - .4744)}{\dot{m}_w ex_{inc} + \dot{E}x_D} = \frac{282.93}{282.93 + 97.2} = \underline{74.4\%}$$

$$\text{Effectiveness II} = \frac{\dot{E}x_{out}}{\dot{E}x_{in}} = \frac{\text{all exergy out (not just the useful)}}{\text{all exergy input}}$$

$$= \frac{\dot{m}_s [(h_e - T_0 S_e) - (h_o - T_0 S_o)]_s + \dot{m}_w [(h_e - T_0 S_e) - (h_o - T_0 S_o)]_w}{\dot{m}_s [(h_i - T_0 S_i) - (h_o - T_0 S_o)]_s + \dot{m}_w [(h_i - T_0 S_i) - (h_o - T_0 S_o)]_w}$$

$$h_o @ 77^\circ\text{F}, 14.696 \text{ psia} = 45.09$$

$$S_o @ 77^\circ\text{F}, 14.696 \text{ psia} = .08775$$

$$\begin{aligned} \text{Eff II} &= \frac{(17.23)[(1227.5 - 537 \times 1.6517) - (45.09 - 537 \times .08775)] + 1[(1187.8 - 537 \times 1.6034) - (2.03)]}{17.23[(1279.1 - 537(1.7085)) - (-2.03)] + 1[(298.61 - 537 \times .4744) - (2.03)]} \\ &= \frac{17.23 [340.53 + 2.03] + 1[326.7 + 2.03]}{17.23 [361.64 + 2.03] + 1[43.86 + 2.03]} = \frac{6231}{6312} = \underline{98.7\%} \end{aligned}$$

Optional Approach

Another very useful way of studying exergy losses in complex systems or cycles is to determine the total exergy loss and then determine the proportion lost in each process. In that way the designer can see where his efforts might be better utilized. For an example of this technique consider the accompanying sketch of a heat pump (using refrigerant 50) with an outdoor temperature of 47°F and a sink temperature of 32°F. A detailed analysis results in the following exergies destroyed.

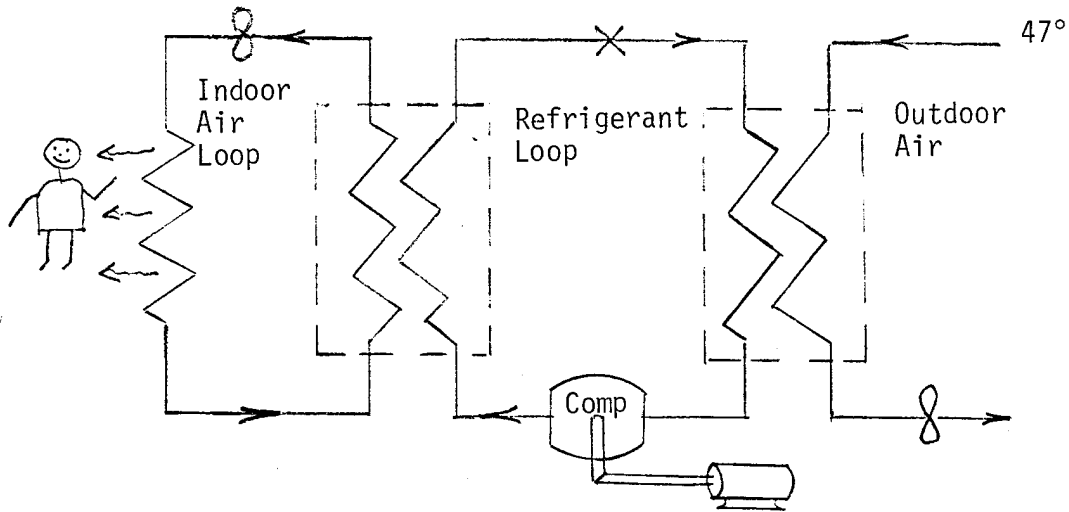

Indoor Fan: 0.55 KW      Ref. Flow: 519.7 lbm/hr.  
 Outdoor Fan: 0.90 KW  
 Room Heating Load: 44,370 Btu/hr  
 Indoor Temp: 75°F

	$\dot{E}_{x_D}$	%
Indoor Unit	2780 Btu/hr	22.4
Inddor fan	1650 Btu/hr	13.3
Expansion Valve	1070 Btu/hr	8.6
Compressor	3350 Btu/hr	27.0
Outdoor Unit	550 Btu/hr	4.4
Outdoor fan	3020 Btu/hr	24.3

In this particular case this indoor unit (heat exchanger) may possibly be modified to decrease its losses.

### Concluding Remarks

The use of the second law via the exergy concept can be a powerful tool in pin pointing losses in engineering systems. However, it is also a powerful tool in highlighting areas which may be fertile for new and innovative techniques. It locates for us the principal regions which beckon the inventor, the innovator, the engineer.

SECTION IV

SELECTED BIBLIOGRAPHY

A REFERENCE GUIDE TO AVAILABLE ENERGY,  
EXERGY, AVAILABILITY FUNCTIONS ETC.

## BIBLIOGRAPHY

- Ahern J. E., "The Exergy Method of Energy Systems Analysis," John Wiley & Sons, NY, 1980.
- Berg, C. A., "Energy Conservation through Effective Utilization," Science, 181, (July 13, 1973), 128.
- Berg, C. A., "A Technical Basis for Energy Conservation," Mechanical Engineering, 96, 5 (May 1974), 3-42.
- Birnie, C., Obert, E. F., "Evaluation and Location of Losses in a 60 MW Power Station," Proc. Midwest Power Conference, 11, (1949), 187-193.
- Briggs, S. W., "Second-Law Analysis of Absorption Refrigeration," A.G.A./I.G.T. Conference on Natural Gas Research and Technology, Chicago, 1971.
- Bruges, E. A., Available Energy and Second Law Analysis, London: Academic Press, 1959.
- Bullock, C. E., "The Application of Availability Analysis to Psychrometric Processes," A.S.H.R.A.E. Symposium Paper, LO-73-4, 1973, 5-16.
- Darrieus, G., "The Rational Definition of Steam Turbine Efficiencies," Engineering, 130, (1930), 283-285.
- Carnahan, W., et.al., "Efficient use of Energy: A Physics Perspective," U. S. Department of Commerce Report #PB-242-773, January 1975.
- Dideon, D., et.al., "A Report on the Relevance of the Second Law of Thermodynamics to Energy Conservation," N.B.S. Technical Note 1115, (August 1980).
- Evans, R. B., "The Formulation of Essergy," Thayer News, Fall, 1968, Thayer School of Engineering, Dartmouth College, Hanover, NH.
- Evans, R. B., "A Proof That Essergy is the Only Consistent Measure of Potential Work (For Work Systems)," Ph.D. Thesis, Dartmouth College, 1969.
- Fehring, T., Gaggioli, R. A., "Economics of Feedwater Heater Replacement," Trans. A.S.M.E. J. Eng. Power, 99, (1977), 482-489.
- Gaggioli, R. A., "Thermodynamics and the Non-Equilibrium System," Ph.D. Dissertation, University of Wisconsin-Madison, 1961.
- Gaggioli, R. A., "The Concept of Available Energy," Chem. Eng. Sci., 16, (1961), 87-96.
- Gaggioli, R. A., "The Concepts of Thermodynamic Friction, Thermal Available Energy, Chemical Available Energy and Thermal Energy," Chem Eng. Sci. 17, (1962), 523-530.
- Gaggioli, R. A., "Reflections on Thermodynamics," Proc. Southeast Seminar on Thermalsciences, U. of Tenn. Space Inst., May 1968.

- Gaggioli, R. A., Yoon, J. J., Patulski, S. A., Latus, A. J., Obert, E. F., "Pinpointing the Real Inefficiencies in Power Plants and Energy Systems," Proc. Amer. Power Conference, 37, 1975, 671-679.
- Gaggioli, R. A., Petit, P. J., "Use the Second Law First," Chemtech, 7, (1977), 496-506.
- Gaggioli, R. A., Wepfer, W. J., "Available-Energy Costing -- A Cogeneration Case Study," Paper presented at the 85th National Meeting of the A.I.Ch.E., Philadelphia, June 8, 1978.
- Gaggioli, R. A., Wepfer, W. J., Chen, H. H., "A Heat Recovery System for Process Steam Industries," Trans. A.S.M.E. J. Eng. Power, 100, (1978), 511-519.
- Gaggioli, R. A., Wepfer, W. J., Elkouh, A. F., "Available Energy Analysis for HVAC, I. Inefficiencies in a Dual-Duct System," Energy Conservation in Building Heating and Air-Conditioning Systems, A.S.M.E. Symposium Volume, H00116, 1978, I-20.
- Gibbs, J. W., The Collected Works, Volumes I, II, New York: Longmans, Green and Co., 1931.
- Gyftopoulos, E. P., Widmer, T., "Effective Energy End-Use," Proc. of Intl. Conference on Energy Use Management, II, Pergamon Press, (1977), 44.
- Gyftopoulos, E. P., Widmer, T. F., "Availability Analysis: The Combined Energy and Entropy Balance," A.C.S. Symposium Volume on Theoretical and Applied Thermodynamics, 1979.
- Hall, E. H., Hanna, W. T., et.al., "Evaluation of the Theoretical Potential for Energy Conservation in Seven Basic Industries," U. S. Department of Commerce Report #FEA/D-75/CE1, July 11, 1975.
- Hatsopoulos, G. N., and Keenan, J. H., Principles of General Thermodynamics, New York, Wiley, 1965.
- Haywood, R. W., "A Critical Review of the Theorems of Thermodynamic Availability with Concise Formulations, Part I Availability," Journal, Mech. Eng. Sci., 16, 3 (1974), 160-173.
- Haywood, R. W., "A Critical Review of the Theorems of Thermodynamic Availability with Concise Formulations, Part II Irreversibility," Journal, Mech. Eng. Sci., 16, 4 (1974), 258.
- Huang, F. F. and Clothier, R. F., "Let us De-mystify the Concept of Entropy," 87th Annual Conference, ASEE, June 1979.
- Keenan, J. H., "Steam Chart for 2nd Law Analysis," Mech. Eng., 54, (March 1932), 195-204.
- Keenan, J. H., Thermodynamics, 1st MIT Press Ed: Cambridge, MA, 1970, Originally published by Wiley, New York, 1941.
- Keenan, J. H., "Availability and Irreversibility in Thermodynamics," Brit. J. of Applied Physics, 2, (1951), 183-192.

- Keller, A., "The Evaluation of Steam Power Plant Losses by Means of the Entropy Balance Diagram," Trans. A.S.M.E., 72, (1959), 949.
- Lopardo, V. J., "Gas Tables 1, 4, 7 Programmed .....", EW Report 9-81, U. S. Naval Academy, 1981.
- Obert, E. F., Thermodynamics, New York, McGraw-Hill, 1948.
- Obert, E. F., Concepts of Thermodynamics, New York, McGraw-Hill, 1960.
- Obert, E. F., and Young, R. L., Elements of Thermodynamics and Heat Transfer, New York, McGraw-Hill, 1962.
- Obert, E. F., and Gaggioli, R. A., Thermodynamics, 2nd Ed., New York, McGraw-Hill, 1963.
- Reistad, G. M., Gaggioli, R. A. and Obert, E. F., "Available Energy and Economic Analyses of Total Energy Systems," Proc. American Power Conference, 32, 1970, 603-611.
- Reistad, G. M., "Availability, Concepts and Applications," Ph.D. Thesis, University of Wisconsin-Madison, 1970.
- Reistad, G. M., "Availability Analysis of the Heating Process and A Heat Pump System," A.S.H.R.A.E. Symposium Paper LO-73-74, 1973, 21-30.
- Reistad, G. M. and Ileri, A., "Effectiveness -- An Idea Whose Time Has Come," Power, (December 1973), 46-47.
- Reistad, G. M. and Ileri, A., "Performance of Heating and Cooling Systems Coupled to Thermal-Electric Power Plants," A.S.M.E. Paper 74-WA/PID-17, 1974.
- Reynolds, W. C. and Perkins, H. C., Engineering Thermodynamics, 2nd Ed., New York, McGraw-Hill, 1977.
- "Second Law Analysis of Energy Devices and Pressure," Proceedings of Workshop at George Washington University, August 1979.
- Sussman, M. V., "Thermodynamic Availability Analysis," Project PROCEED, MIT, Cambridge, MA, 1976, 69-569.
- Sussman, M. R., "Availability (Exergy) Analysis," Tufts University, 1980.
- Van Wylen, G. J. and Sonntag, R. E., Fundamentals of Classical Thermodynamics, 2nd Ed., New York, Wiley, 1973.
- Vivarelli, R. and Sciubba, E., ... " Sull'impiego della grandezza exergia nell' analisi di trasformazioni termodinamiche Part I, Part II," XXX Congresso Nazionale AII, September 1975.
- Wepfer, W. J., Gaggioli, R. A. and Obert, E. F., "Proper Evaluation of Available Energy for HVAC," Trans. A.S.H.R.A.E., 85, 1 (1979).

Wepfer, W. J. and Gaggioli, R. A., "Reference Datums for Available-Energy Analyses," A.C.S. Symposium, Volume on Theoretical and Applied Thermodynamics, 1979.

Wepfer, W. J., "Application of the Second Law to the Analysis and Design of Energy Systems," Ph.D. Dissertation, University of Wisconsin-Madison, 1979.