

REPORT DOCUMENTATION PAGE

Form Approved
OMB No. 0704-0188

Public reporting burden for this collection of information is estimated to average 1 hour per response, including the time for reviewing instructions, searching existing data sources, gathering and maintaining the data needed, and completing and reviewing the collection of information. Send comments regarding this burden estimate or any other aspect of this collection of information, including suggestions for reducing this burden, to Washington Headquarters Services, Directorate for Information Operations and Reports, 1215 Jefferson Davis Highway, Suite 1204, Arlington, VA 22202-4302, and to the Office of Management and Budget, Paperwork Reduction Project (0704-0188), Washington, DC 20503.

1. AGENCY USE ONLY (Leave blank)	2. REPORT DATE June 5, 1995	3. REPORT TYPE AND DATES COVERED Final Technical Report, 4/1/93-1/31/95
----------------------------------	--------------------------------	--

4. TITLE AND SUBTITLE Theoretical and Experimental Investigation of Electron Beam Acceleration and Submillimeter Wave Generation	5. FUNDING NUMBERS DAAH04-93-G-0084
---	--

6. AUTHOR(S) N.C. Luhmann, Jr. and D.B. McDermott	
--	--

7. PERFORMING ORGANIZATION NAME(S) AND ADDRESS(ES) Department of Electrical Engineering University of California, Los Angeles Los Angeles, CA 90024	8. PERFORMING ORGANIZATION REPORT NUMBER
--	--

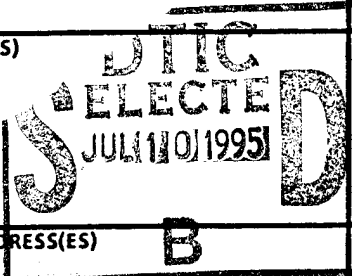

9. SPONSORING/MONITORING AGENCY NAME(S) AND ADDRESS(ES) U. S. Army Research Office P. O. Box 12211 Research Triangle Park, NC 27709-2211	10. SPONSORING/MONITORING AGENCY REPORT NUMBER ARO 30269.19-PH
---	---

11. SUPPLEMENTARY NOTES
The view, opinions and/or findings contained in this report are those of the author(s) and should not be construed as an official Department of the Army position, policy, or decision, unless so designated by other documentation.

12a. DISTRIBUTION/AVAILABILITY STATEMENT Approved for public release; distribution unlimited.	12b. DISTRIBUTION CODE
--	------------------------

13. ABSTRACT (Maximum 200 words)

The objective of our research for ARO is to investigate the physics as well as to develop the technology of compact submillimeter-wave devices. (1) A revolutionary new device, the gyrofrequency multiplier, which can potentially generate 50 kW at 1-2 THz by using a 140 GHz gyrotron as its input source, has been tested in our laboratory. (2) Our second-harmonic gyro-TWT amplifier, which is based on our recent marginal stability design (MSD) procedure, yielded extremely good results, including a record-setting output power of 207 kW, with 13% efficiency, 16 dB saturated gain, 2% bandwidth and was completely stable. (3) The MSD procedure was also used to design two other stable, high performance amplifiers: a 1 MW, 140 GHz, third-harmonic gyro-TWT and a 100 kW CW, 95 GHz, TE₀₁ gyro-TWT. (4) We have also begun a major new program to develop high power, ultra-wideband prebunched FELs for radar applications using a photoemitted rf gun. (5) We have also continued to construct a high-performance 250 kW CW, 33.2 GHz TE₀₁/TE₀₂ gyroklystron amplifier and begun a 70 kW CW, 95 GHz, third-harmonic, smooth-bore gyroklystron amplifier program.

14. SUBJECT TERMS submillimeter-wave, gyrofrequency multiplier, harmonic gyro-TWT amplifier, stability, gyroklystron amplifier, FEL, photoemitted rf gun	15. NUMBER OF PAGES 13
	16. PRICE CODE

17. SECURITY CLASSIFICATION OF REPORT UNCLASSIFIED	18. SECURITY CLASSIFICATION OF THIS PAGE UNCLASSIFIED	19. SECURITY CLASSIFICATION OF ABSTRACT UNCLASSIFIED	20. LIMITATION OF ABSTRACT UL
---	--	---	----------------------------------

FINAL TECHNICAL REPORT
 FORTY COPIES REQUIRED

1. ARO PROPOSAL NUMBER: 30269-PH
2. PERIOD COVERED BY REPORT: 1 April 1993 - January 31 1995
3. TITLE OF PROPOSAL: Theoretical and Experimental Investigation of Electron Beam Acceleration and Submillimeter Wave Generation
4. CONTRACT OR GRANT NUMBER: DAAH04-93-G-0084
5. NAME OF INSTITUTION: University of California, Los Angeles
6. AUTHORS OF REPORT: N.C. Luhmann, Jr. and D.B. McDermott
7. LIST OF MANUSCRIPTS SUBMITTED OR PUBLISHED UNDER ARO SPONSORSHIP DURING THIS REPORTING PERIOD, INCLUDING JOURNAL REFERENCES:

See attached

8. SCIENTIFIC PERSONNEL SUPPORTED BY THIS PROJECT AND DEGREES AWARDED DURING THIS REPORTING PERIOD:

Prof. N.C. Luhmann, Jr.
 Dr. D.B. McDermott
 Dr. F.V. Hartemann

Mr. A.J. Balkcum (M.S. Degree Awarded 1/95)	For	<input type="checkbox"/>
Mr. J.D. McNally (M.S. Degree Awarded 4/95)		<input checked="" type="checkbox"/>
Mr. M.P. Bobys (M.S. Degree Awarded 12/93)		<input type="checkbox"/>
Mr. K.C. Leou (Ph.D. Degree Awarded 1/94)		<input type="checkbox"/>
Mr. Q.S. Wang (Ph.D. Degree Awarded 1/95)	on	

9. REPORT OF INVENTIONS (BY TITLE ONLY):

None

Distribution/	
Availability Codes	
Dist	Avail and/or Special
A-1	

N.C. Luhmann, Jr.
 Department of Electrical Engineering
 University of California, Los Angeles
 Los Angeles, CA 90024

19950703 312

MANUSCRIPTS AND PRESENTATIONS (4/1/93 - 1/31/95)

"High-Harmonic Gyrofrequency Multiplier," IA.J. Balkcum, D.B. McDermott, K.C. Leou, F.V. Hartemann, and N.C. Luhmann, Jr., *EEE Trans. on Plasma Science*, 22, 913 (1994).

"Design of 1 MW, 140 GHz Third-Harmonic TE₃₁ Gyro-TWT Amplifier," Q.S. Wang, D.B. McDermott, C.K. Chong, C.S. Kou, K.R. Chu, and N.C. Luhmann, Jr., *IEEE Trans. on Plasma Science*, 22, 608 (1994).

"High Performance, 70 kV Third-Harmonic Smooth-Bore Gyroklystron Amplifier," J.D. McNally, D.B. McDermott, Q.S. Wang, F.V. Hartemann, and N.C. Luhmann, Jr., *EEE Trans. on Plasma Science*, 22, 932 (1994).

"Stable High Power TE₀₁ Gyro-TWT Amplifier," K.C. Leou, D.B. McDermott, A.J. Balkcum, and N.C. Luhmann, Jr., *EEE Trans. on Plasma Science*, 22, 585 (1994).

"Time and Frequency Domain Analysis of Superradiant Coherent Synchrotron Radiation in a Waveguide Free-Electron Laser," A. Gover, F.V. Hartemann, G.P. Le Sage, N.C. Luhmann, Jr., R.S. Zhang and C. Pellegrini, *Phys. Rev. Lett.* 72, 1192 (1994).

"Coherent Photoelectron Bunch Generation and Quantum Efficiency Enhancement in a Photocathode Optical Resonator," F.V. Hartemann, S.N. Fochs, J.D. McNally, N.C. Luhmann, Jr., M.D. Perry, and K.R. Chu, *Applied Physics Letters* 65, 2404 (1994).

"Classical Electrodynamical Derivation of the Radiation Damping Force," F.V. Hartemann and N.C. Luhmann, Jr., to be published, *Phys. Rev. Lett.*, 74, No. 7, 1995.

K.C. Leou, Q.S. Wang, C.K. Chong, A.J. Balkcum, S.N. Fochs, E. Garland, J. Pretterebner, A.T. Lin, D.B. McDermott, F. Hartemann, and N.C. Luhmann, Jr., "Gyro-TWT Amplifiers at UCLA," *Digest of Int. Conf. on IR and Millimeter Waves*, 1993.

A.J. Balkcum, D.B. McDermott, F. Hartemann, and N.C. Luhmann, Jr., "150 kW Sixth-Harmonic Gyro-Multiplier," *Digest of Int. Conf. on IR and Millimeter Waves*, 1993.

C.K. Chong, Q.S. Wang, K.C. Leou, J.D. McNally, M.P. Bobys, A.J. Balkcum, D.B. McDermott, F. Hartemann, J. Pretterebner, A.T. Lin, and N.C. Luhmann, Jr., "High-Harmonic Gyro-Amplifiers," submitted to *Proceedings of Second Annual Vacuum Electronic Conf.*, 1993.

J.D. McNally, M.P. Bobys, F.V. Hartemann, D.B. McDermott, and N.C. Luhmann, Jr., "Gyroklystron Amplifiers at UCLA," *Proceedings of Asia-Pacific Conference*, 1993.

A.J. Balkcum, D.B. McDermott, F. Hartemann, and N.C. Luhmann, Jr., "150 kW Sixth-Harmonic Gyrofrequency Multiplier," *Proceedings of Asia-Pacific Conference*, 1993.

K.C. Leou, Q.S. Wang, C.K. Chong, A.J. Balkcum, J. Pretterebner, A.T. Lin, D.B. McDermott, F. Hartemann, and N.C. Luhmann, Jr., "Recent UCLA Fast-Wave "Amplifier Developments," *Proceedings of Asia-Pacific Conference*, 1993.

A.J. Balkcum, D.B. McDermott, F.V. Hartemann, and N.C. Luhmann, Jr., "High Harmonic Gyrofrequency-Multiplier," *Bull. Am. Phys. Soc.* 38, 2000 (1993).

J.D. McNally, M.P. Bobys, D.B. McDermott, F.V. Hartemann, and N.C. Luhmann, Jr., "Smooth-Bore Third-Harmonic TE₃₁₁ Gyro-Klystron," *Bull. Am. Phys. Soc.* 38, 2001 (1993).

Q.S. Wang, D.B. McDermott, F.V. Hartemann, E.S. Garland, and N.C. Luhmann, Jr., "High Power, Second Harmonic TE₂₁ Gyro-TWT," *Bull. Am. Phys. Soc.* 38, 2000 (1993).

"High Harmonic Gyrofrequency-Multiplier," A.J. Balkcum, D.B. McDermott, F.V. Hartemann, and N.C. Luhmann, Jr., Proc. of *SPIE Conf. on High Power Microwaves*, Los Angeles, CA, 1994.

"High Power, 95 GHz Ultra Wideband Prebunched Photocathode FEL for Radar Applications," F.V. Hartemann, G.P. LeSage, D.B. McDermott, and N.C. Luhmann, Jr., Proc. of *SPIE Conf. on High Power Microwaves*, Los Angeles, CA, 1994.

"High Harmonic Gyrofrequency Multiplier," A.J. Balkcum, D.B. McDermott, F.V. Hartemann, and N.C. Luhmann, Jr., Digest of *Microwave Power Tube Conference*, 3D.1, Monterey, CA, 1994..

"Recent Gyro-TWT Amplifier Developments at UCD," K.C. Leou, Q.S. Wang, D.B. McDermott, F.V. Hartemann, C.K. Chong, and N.C. Luhmann, Jr., Digest of *Microwave Power Tube Conference*, 3B.5, Monterey, CA, 1994.

"Smooth-Bore Third-Harmonic TE₃₁₁ Gyroklystron," J.D. McNally, D.B. McDermott, F.V. Hartemann, and N.C. Luhmann, Jr., Digest of *Microwave Power Tube Conference*, 2E.3, Monterey, CA, 1994.

"High Power, 95 GHz Ultra Wideband Multibunch Photocathode FEL for Radar Applications," F.V. Hartemann, S.N. Fochs, J.D. McNally, D.B. McDermott, and N.C. Luhmann, Jr., Digest of *Microwave Power Tube Conference*, 2E.4, Monterey, CA, 1994.

"A 2 MW, 95 GHz Ultra Wideband Prebunched Photocathode FEL for Radar Applications," F.V. Hartemann and N.C. Luhmann, Jr., *AGARD/NATO Conf. on High Power Microwaves*, Ottawa, Canada, 1994.

"Coherent Synchrotron Radiation in an Ultra-Short Pulse Multibunch Photocathode Free-Electron Laser," F.V. Hartemann, G.P. LeSage, S.N. Fochs, J.D. McNally, D.B. McDermott, J.P. Heritage, N.C. Luhmann, Jr., M.D. Perry, and G.A. Westenskow, *Bull. Am. Phys. Soc.* 39, 1620 (1994).

"High Power, nth-Harmonic TE_{n1} Gyro-TWT's: 200 kW Second-Harmonic Results and 1 MW Third-Harmonic Design," Q.S. Wang, D.B. McDermott, A.J. Balkcum and N.C. Luhmann, Jr., *Bull. Am. Phys. Soc.* 39, 1742 (1994).

"Sixth-Harmonic Gyrofrequency Multiplier Results," A.J. Balkcum, D.B. McDermott and N.C. Luhmann, Jr., *Bull. Am. Phys. Soc.* 39, 1742 (1994).

"Stable High-Performance TE₀₁ Gyro-TWT," D.B. McDermott, K.C. Leou, C.K. Chong and N.C. Luhmann, Jr., *Bull. Am. Phys. Soc.* 39, 2000 (1994).

"Nonlinear Laser Acceleration in Vacuum," F.V. Hartemann, S.N. Fochs, G.P. LeSage, N.C. Luhmann, Jr., M.D. Perry, and G.A. Westenskow, *Bull. Am. Phys. Soc.* 39, 1553 (1994).

"Multibunch X-Band Photoinjector," G.P. LeSage, F.V. Hartemann, S.N. Fochs, N.C. Luhmann, Jr., J.P. Heritage, M.D. Perry, and G.A. Westenskow, *Bull. Am. Phys. Soc.* 39, 1620 (1994).

"GigaHertz Repetition Rate AlGaAs/Ti:Sapphire MOPA Laser System for Advanced Photoinjectors," S.N. Fochs, F.V. Hartemann, G.P. LeSage, N.C. Luhmann, Jr., J.P. Heritage, M.D. Perry, and G.A. Westenskow, *Bull. Am. Phys. Soc.* 39, 1620 (1994).

"Gyro-TWT Amplifier Development at UCD," Q.S. Wang, K.C. Leou, C.K. Chong, A.J. Balkcum, D.B. McDermott, and N.C. Luhmann, Jr., *Digest of 19th Int. Conf. on Infrared and Millimeter Waves*, Sendai, Japan, 1994.

"Novel Multibunch RF Guns Using Photocathode Optical Resonators for Coherent Infrared and Millimeter-Wave Applications," S.N. Fochs, G.P. LeSage, J.D. McNally, F.V. Hartemann, M.D. Perry, G.A. Westenskow, Y.J. Chen, D.B. McDermott, J.P. Heritage, and N.C. Luhmann, Jr., *Digest of 19th Int. Conf. on Infrared and Millimeter Waves*, Sendai, Japan, 1994.

"High-Harmonic Gyrofrequency Multiplier," A.J. Balkcum, D.B. McDermott, F.V. Hartemann, and N.C. Luhmann, Jr., *Digest of 19th Int. Conf. on Infrared and Millimeter Waves*, Sendai, Japan, 1994.

"GigaHertz Repetition Rate AlGaAs/Ti:Sapphire MOPA Laser System for Advanced Photoinjectors," S.N. Fochs, G.P. LeSage, J.D. McNally, F.V. Hartemann, N.C. Luhmann, Jr., M.D. Perry, J.P. Heritage, and P.J. Delfyett, LEOS '94, Boston, MA, 1994.

"Quantum Efficiency Enhancement and Generation of Coherent Photoelectron Bunch Trains in a Photocathode Optical Resonator," S.N. Fochs, G.P. LeSage, J.D. McNally, F.V. Hartemann, N.C. Luhmann, Jr., M.D. Perry, K.R. Chu, and J.P. Heritage, LEOS '94, Boston, MA, 1994.

BRIEF OUTLINE OF RESEARCH FINDINGS (4/1/93-1/31/95)

OVERVIEW

Several innovative millimeter-wave devices have been developed and successfully tested during the period of performance last year. Our research emphasis has been on harmonic devices in order to reduce the magnetic field required by high performance gyrotron sources. (1) A revolutionary new device, the gyrofrequency multiplier, which can potentially generate 50 kW at 1-2 THz by using a 140 GHz gyrotron as its input source, has been tested in our laboratory. The recent experiment generated 3.5 kW at the sixth-harmonic with a conversion efficiency of 4.5% and an upgrade sixth-harmonic experiment has been planned to produce 150 kW with 30% efficiency. (2) Our second-harmonic gyro-TWT amplifier yielded extremely good results. It generated a record-setting output power of 207 kW, with 13% efficiency, 16 dB saturated gain, 2% bandwidth and was completely stable. Its design was based on our Marginal Stability Design Procedure (MSDP) for stabilizing high power gyro-TWTs and our theory that harmonic gyro-TWTs are capable of significantly higher power because the stronger fundamental-harmonic interaction restricts the beam current to low levels for stability. This concept has been extended to design a stable 1 MW, 140 GHz, third-harmonic gyro-TWT amplifier that requires a magnetic field of only 17 kG. (3) The MSDP was also used to design stable high-performance, 35 GHz and 95 GHz, CW TE₀₁ gyro-TWT amplifiers. The TE₀₁ mode is extremely attractive because of its low Ohmic dissipation. (4) We have also begun a major new program to develop high power, ultra-wideband prebunched FELs for radar applications. The short-pulse photoemitted electron beamlets from an rf linac cavity and a fast laser will efficiently emit throughout the millimeter range in a resonant FEL wiggler if the electron bunch length is less than the rf wavelength. The table-top uv laser has been partially tested and a high power, state-of-the-art X-Band klystron has been acquired from SLAC. A compact, light weight design utilizing a standard X-Band magnetron has also been developed. (5) We have continued to construct a high-performance 250 kW, 33.2 GHz TE₀₁/TE₀₂ gyroklystron amplifier. In addition, we have also planned an experiment to test our 70 kW, 95 GHz, third-harmonic, smooth-bore gyroklystron design, which is a much more robust structure than the slotted third-harmonic gyroklystron being built by Litton under ARPA's fast-wave amplifier program.

A. High Harmonic Gyrofrequency Multiplier

A revolutionary new concept for the efficient production of high power millimeter and submillimeter wave radiation, which was conceived by our group, has been successfully tested in a second proof-of-principle experiment. A gyrofrequency multiplier emits at a high harmonic of the cyclotron frequency, making it possible to operate with significantly reduced magnetic fields and to multiply the frequency of existing high-power microwave sources. As shown in Fig. 1, in the input

cavity, low frequency microwaves tuned to the cyclotron frequency accelerate and bunch an electron beam, which then emits at a high harmonic of the cyclotron frequency in the output cavity with all electrons optimally phased to give up energy, resulting in extremely high efficiency. Our initial proof-of-principle experiment in 1988 at the third harmonic resulted in the generation of 7 kW at 28 GHz with 13% efficiency.

The goals of our recent experiment were to significantly increase the harmonic number, power level and efficiency of our pioneering proof-of-principle experiment. By converting a 2.9 GHz input signal to 17.4 GHz, the sixth-harmonic gyrofrequency multiplier generated 3.5 kW with a conversion efficiency of 4.5%. The sixth-harmonic gyrofrequency multiplier whose experimental parameters are shown in Table 1 had been designed by using a simulation code and, as can be seen in Fig. 2, the results are in fairly good agreement with the predictions. The discrepancy can be accounted for by beam loading effects in the output cavity. A self-consistent linear gyrotron code predicts that the frequency shift from the beam is approximately equal to the 3 dB width of the resonant mode, which results in nearly perfect agreement in Fig. 2 between the experiment and simulation by changing Q_L by two. To replace the cavity and thereby avoid beam-loading, a traveling wave interaction circuit is being constructed for the sixth-harmonic upgrade experiment, which is predicted to produce 150 kW with 30% efficiency.

Much higher power gyrofrequency multipliers will later be experimentally investigated using our 20 MW, 8.6 GHz SLAC klystron to generate radiation in the 86-172 GHz region at harmonics from ten to twenty with power levels up to 2 MW. Eventually, we intend to build a tenth-harmonic multiplier to convert the 1 MW output of a 140 GHz gyrotron into 50 kW of 1.4 THz power.

B. High-Power n^{th} -Harmonic TE_{n1} Gyro-TWT Amplifiers

Gyro-TWT amplifiers offer high average power at high frequency, but have historically displayed poor stability. Our group has been successful in developing the gyro-TWT into the stable, high-performance amplifier that it was initially envisioned to be. Using the MSDP design procedure that considers the threshold conditions for the various types of oscillation, we have recently built and tested two stable high-performance gyro-TWT amplifiers: a wideband gyro-TWT that displayed a constant-drive bandwidth of 11% and a third-harmonic slotted gyro-TWT designed for operation at 94 GHz in collaboration with Varian Associates.

In addition, in our ARO-funded program, we have developed and tested an extremely high power, smooth-bore, second-harmonic gyro-TWT. Harmonic gyro-TWT's not only require a substantially weaker magnetic field and offer nearly the same high efficiency as fundamental gyro-TWT's, but also can generate significantly higher power levels. Basically, since harmonic interactions are weaker than the fundamental interaction, the start-oscillation beam current is raised significantly. A feature of our n^{th} -harmonic TE_{n1} gyro-TWT's is that the stronger first-harmonic

interaction cannot occur, since the fundamental cyclotron resonance line does not intersect the lowest order mode as seen in Fig. 3.

Our second-harmonic gyro-TWT amplifier (see Table 2) used an 80 kV, 20 A MIG electron gun and generated a record-setting output power of 207 kW. That the highest output power from a stable first-harmonic gyro-TWT is only 120 kW is verification of our claim that harmonic gyro-TWTs can stably generate higher power. Additionally, our device's characteristics included an efficiency of 13% efficiency, 16 dB saturated gain, 2% bandwidth (see Fig. 4) and was completely stable without any rf input power drive. The amplifier's transfer curve (see Fig.5) shows well-behaved linear and saturated nonlinear regions and confirms the theoretical prediction that the growth rate is proportional to the cube root of the beam current. For detuned, higher gain conditions, our gyro-TWT was stable for gains as high as 39 dB as shown in Fig. 6. The amplifier's excellent stability is due to the well matched circuit components. The overmoded TE₂₁ input/output directional coupler had been designed with the Hewlett-Packard HFSS 3-D electromagnetics design code. The measured coupling data are in excellent agreement with the HFSS predictions as shown in Fig. 7. All modes are well terminated in this coupler with a return loss of >20 dB over a 20% bandwidth, which is crucial for the amplifier's stability. The entire device was built as a sealed-off demountable tube.

The above concept has been extended to design a higher power, 140 GHz, third-harmonic TE₃₁ gyro-TWT amplifier. The device described in Table 3 employs a 100 kV, 50 A MIG gun and is predicted by a simulation code to generate 900 kW with 18% efficiency, 30 dB saturated gain and a bandwidth of 6% as shown in Fig. 8. Its stability is ensured by limiting the length of the interaction section to the shortest gyro-BWO start-oscillation length. The 1 MW, 140 GHz, third-harmonic gyro-TWT amplifier would require a magnetic field of only 17 kG. A scaled device in a 50 kG magnet would generate 400 GHz.

C. Overmoded Gyro-TWT Stability--95 GHz Multi-Section TE₀₁ Gyro-TWT

We also employed the MSDP procedure to design high-performance 35 GHz and 95 GHz gyro-TWTs using the TE₀₁ mode, which offers low ohmic dissipation and a favorable interaction strength. Linear theory has been used to determine the threshold conditions for harmonic gyrotron and gyro-BWO oscillation in all waveguide modes. Using interaction sections shorter than the threshold oscillation length and separated by attenuating severs for isolation, a stable three-section amplifier has been designed (see Table 4) that is predicted by a simulation code to yield 105 kW at 94 GHz with 21% efficiency, 45 dB saturated gain and 5% constant-drive bandwidth (see Fig. 9) for a 100 kV, 5 A electron beam. The 35 GHz design with a 10 A beam is predicted to yield 230 kW with 23% efficiency. In addition, the 0 dB quad-feed input/output couplers (see Fig. 10) and an appropriate MIG electron gun has been designed with 2.4% axial velocity spread. Due to the low loss of the circular TE₀₁ mode, this high-performance amplifier can be operated continuously.

D. Short-Pulse Wideband Emission from RF Photocathode Beams

We have also begun a major new program to develop an innovative, compact rf accelerator system that can be used to generate high power, ultra-wideband millimeter-waves for radar applications. A wavetrain of short-pulse photoemitted electron beamlets from an rf linac cavity and a short pulse ($\cong 200$ fsec) laser will coherently emit in an FEL wiggler when the electron bunch length is less than the rf wavelength. The electrons are effectively prebunched and the entire beamlet will efficiently radiate.

We have been actively involved in the design and construction of a compact state-of-the-art rf photoinjector capable of accelerating trains (up to 100) of high charge (1 nC), ultrashort (< 5 ps) photoelectron bunches to energies up to 5 MeV with excellent beam quality (emittance $< 5\pi$ mm-mrad) at a repetition rate of 2.142 GHz (one bunch every fourth rf cycle). Such a device has many potential applications ranging from laser acceleration to chirped-pulse free-electron lasers and ultra-wideband radars. The photoelectron bunches are produced by illuminating a high quantum efficiency ($> 5\%$) Cesium Telluride photocathode with the 200 fs, 0.1 GW frequency-quadrupled UV pulses from an eight-pass bow-tie Ti:Al₂O₃ laser amplifier that is driven by a low jitter (400 fs) mode-locked AlGaAs quantum-well laser. The simulation codes SUPERFISH and PARMELA are being used to optimize the design of the 1 1/2 cell linac cavity that will be driven by our 20 MW, 8.568 GHz SLAC klystron. We are also beginning studies of a magnetron driven system which would be suitable for transportable and airborne applications.

E. High-Power Smooth-Bore Gyroklystron Amplifiers

We have also continued the construction of our high-performance 33 GHz TE₀₁/TE₀₂ gyro-klystron amplifier (see Table 5), which is predicted to yield an output power of 250 kW with an efficiency of 39% and a saturated gain of 52 dB as shown in Fig. 11 by using an 80 kV, 8 A electron beam. Because it uses the low loss TE_{0n} modes, the wall loading is weak and the device can be operated cw. Most of the major equipment for the experiment have been assembled and tested. We are ready to begin machining the cavities.

In addition, we are planning an experiment to test our 70 kW, 95 GHz, third-harmonic, smooth-bore gyro-klystron design by using the axis-encircling electron beams produced by our gyroresonant rf accelerator cavity. In an ARPA funded program, Litton is developing a third-harmonic gyro-klystron utilizing a slotted waveguide circuit to increase the interaction strength. The purpose of our study is to determine whether more robust smooth-bore waveguide can be used.

An important feature of our proposed smooth-bore third-harmonic TE₃₁₁ gyrokystron is that it is stable, because the axis-encircling beam will not interact at the stronger, lower cyclotron harmonic frequencies. The three-cavity third-harmonic gyrokystron (Table 6) is predicted from our gyrokystron simulation code to yield 70 kW with 20% efficiency, 0.2% bandwidth and a saturated gain of 35 dB as can be seen in Fig. 12.

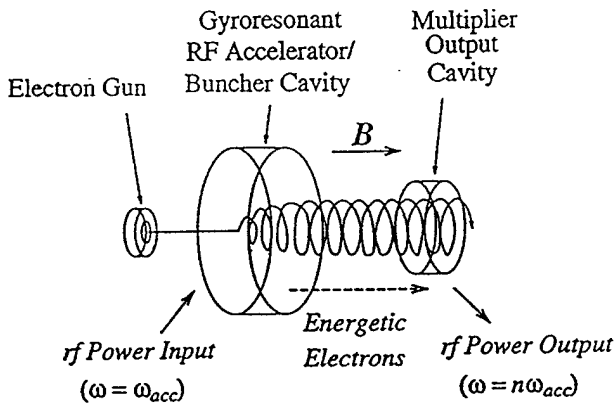

Fig. 1. Schematic of the high-harmonic gyrofrequency multiplier.

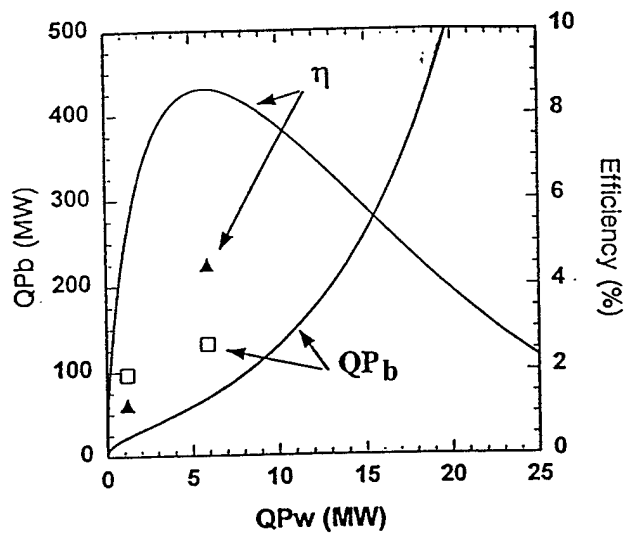

Fig. 2. Dependence of simulated efficiency and beam power times cavity Q (lines) on wave power times cavity Q in the gyrofrequency multiplier's output cavity for the experimental beam parameters of Table 1 and compared to the experimental efficiency (triangles) and beam power (squares).

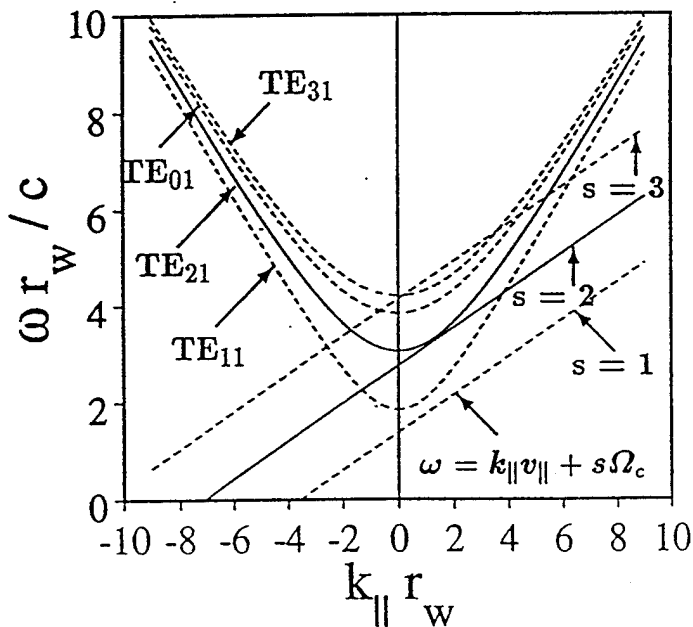

Fig. 3. Uncoupled dispersion relation of operating mode (intersection of unbroken curves) and likely oscillating modes (intersections of broken curves with negative k_z) for second-harmonic TE_{21} gyro-TWT amplifier (100 kV, $\alpha = 1, B_0 = 0.98 B_g$).

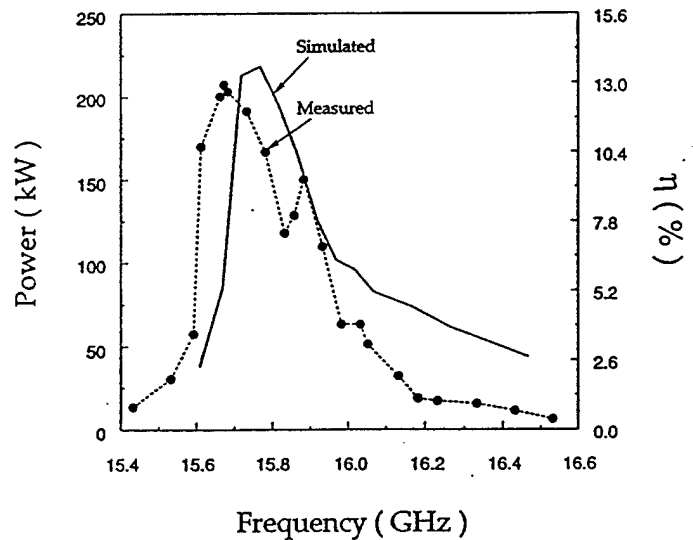

Fig. 4. Measured saturated bandwidth of the second-harmonic TE_{21} gyro-TWT amplifier showing a peak output power of 207 kW and peak efficiency of 13%. The solid curve represents the simulated results for an 80 kV, 20 A beam with $\alpha = 1.1$ in a magnetic field of $B/B_g = 0.97$.

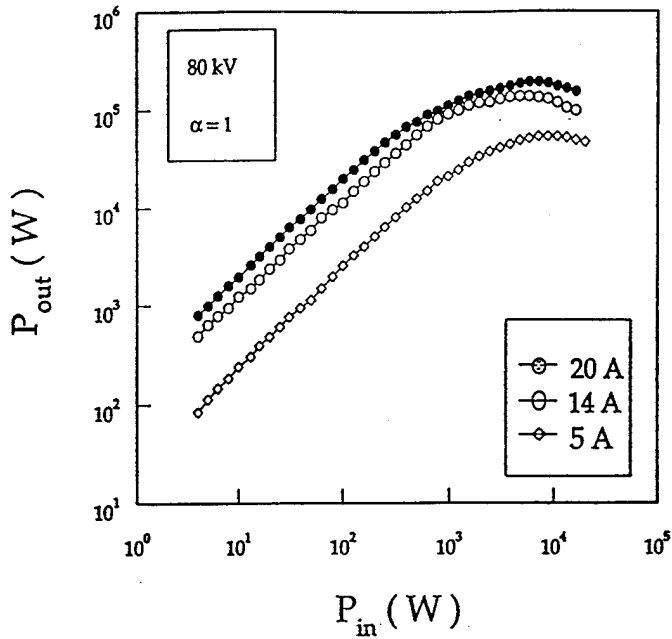

Fig. 5. Measured amplifier transfer curve of second-harmonic TE₂₁ gyro-TWT for beam currents of 5, 14 and 20 A with the same magnetic field and at the same frequency of 15.7 GHz.

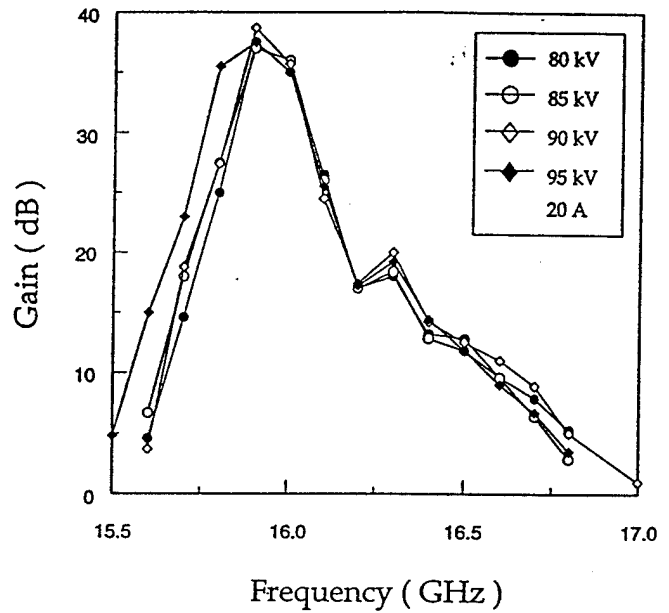

Fig. 6 Measured small signal gain bandwidth for the TE₂₁ gyro-TWT amplifier with a 20 A beam at different beam voltages (80, 85, 90 and 95 kV).

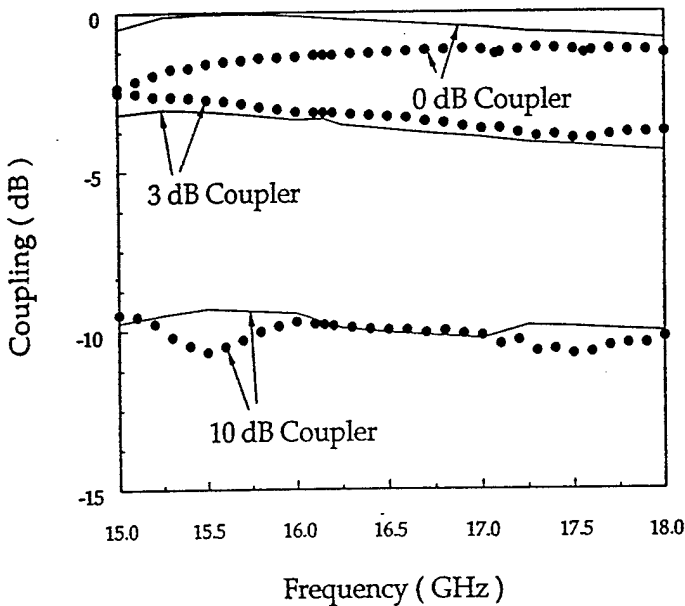

Fig. 7. Performance of 0 dB, 3 dB and 10 dB TE₂₁ input/output couplers as simulated by HFSS. Solid dots are cold test results.

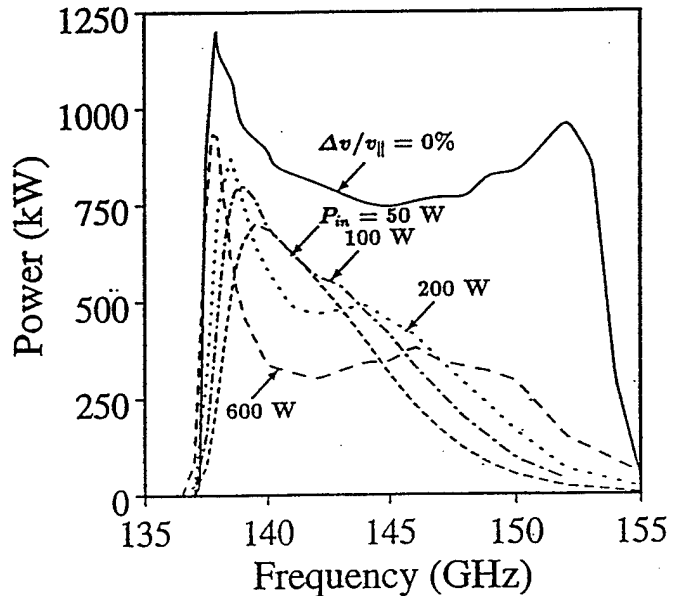

Fig. 8 Bandwidth of proposed third-harmonic single-section TE₃₁ gyro-TWT amplifier (Table 3) for axial velocity spreads of 0% (solid curve) and 5% (dot and dashed curves).

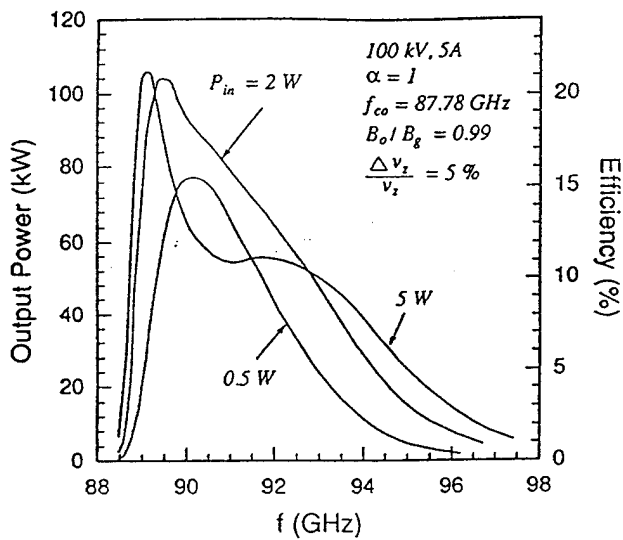

Figure 9. Constant-drive bandwidth for TE₀₁ gyro-TWT amplifier for three values of input power ($P_{in} = 1, 6$ and 12 W; Table 3).

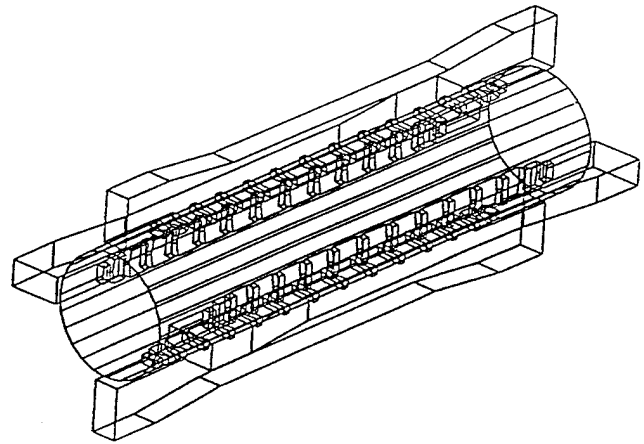

Figure 10. Schematic of rectangular TE₁₀ to circular TE₀₁ directional coupler with four rectangular feeds.

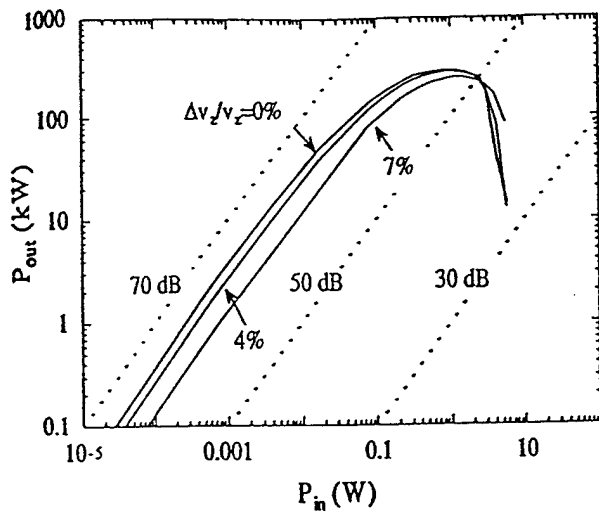

Fig. 11 Gain characteristics of the 33.2 GHz, three-cavity TE₀₁/TE₀₂ gyrokystron amplifier for several values of axial velocity spread.

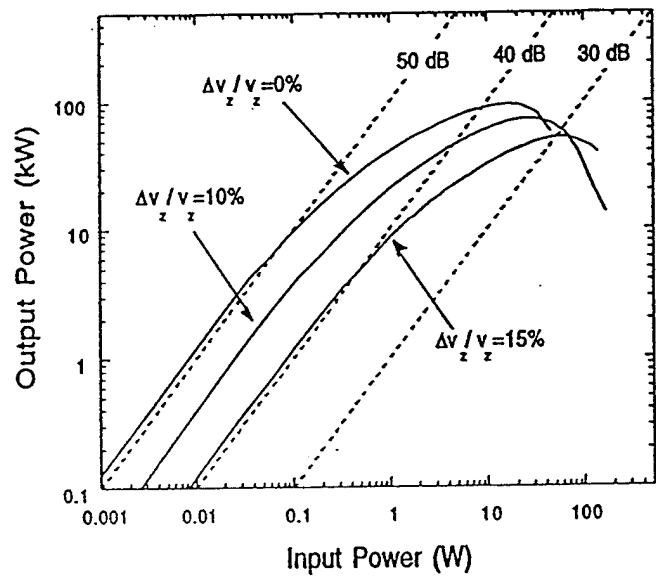

Fig. 12 Gain characteristics of the 95 GHz, three-cavity third-harmonic TE₃₁₁ gyrokystron amplifier for several values of axial velocity spread.

Tables

Table 1. Experimental Parameters for the Sixth-Harmonic Gyrofrequency Multiplier Experiment.

Input Power	320 kW
Input Frequency	2.872 GHz
Beam Voltage	260 kV
Beam Current	0.3 A
$\alpha (= v_{\perp}/v_z)$	4.8
Guiding-Center Radius	0.0 cm
Radial Guiding-Center Spread	0.09 cm
Accelerator Cavity Length/Radius	0.91
Accelerator Cavity Q	3200
Accelerator Cavity Mode	TE ₁₁₁
Output Cavity Length/Radius	4.0
Output Cavity Q	1700
Output Cavity Mode	TE ₆₁₂
Magnetic Field	1.50 kG
Magnetic Linear Downtaper	2.4%

Table 3. Design Parameters for Single-Section, Sliced, 140 GHz Third-Harmonic TE₃₁ Gyro-TWT Amplifiers with MIG Electron Beam.

Beam Voltage	100 kV
Beam Current	50 A
$\alpha (= v_{\perp}/v_z)$	1.0
Magnetic Field	17 kG
Center Frequency	140 GHz
Mode	TE ₃₁
Cyclotron Harmonic	3
Circuit Radius	0.15 cm
r_c/r_w	0.3
B/B _g	0.99
$\Delta v_z/v_z$	5%
$\Delta r_c/r_w$	10%
Number of Sections	1
Circuit Length	10 cm

Table 5. Design Parameters Of TE₀₁/TE₀₂ Three-Cavity Gyro-Klystron Amplifier under Construction.

Beam Voltage	80 kV
Beam Current	8 A
$\alpha (= v_{\perp}/v_z)$	1.5
Frequency	33.2 GHz
Magnetic Field	12.4 kG
Mode (1,2,3)	TE ₀₁₁ , TE ₀₁₁ , TE ₀₂₁ ,
Cavity Q (1,2,3)	300, 300, 550
Cyclotron Harmonic	1
Cavity Lengths	2.0 λ
Drift Tube Lengths	3.0 λ
$\Delta r_c/r_w$	10%
$\Delta v_z/v_z$	7%

Table 2. Experimental Parameters for Sliced, Single-Stage, 16 GHz Second-Harmonic TE₂₁ Gyro-TWT Amplifier with MIG Electron Beam.

Beam Voltage	80 kV
Beam Current	20 A
Magnetic Field	3.4 kG
Center Frequency	15.7 GHz
Cutoff Frequency	15.3 GHz
Mode	TE ₂₁
Cyclotron Harmonic	2
Circuit Radius	0.95 cm
r_c/r_w	0.4
$\alpha (= v_{\perp}/v_z)$	1.1
B/B _g	0.97
$\Delta v_z/v_z$	14%
$\Delta r_c/r_w$	10%
Number of Sections	1
Circuit Length	65 cm

Table 4. Design Parameters for High-Performance 94 GHz TE₀₁ Gyro-TWT Amplifier.

Center Frequency	94 GHz
Beam Voltage	100 kV
Beam Current	5 A
$\alpha (= v_{\perp}/v_z)$	1.0
Magnetic Field	34.2 kG
Mode	TE ₀₁
Cyclotron Harmonic	1
Circuit Radius	0.21 cm
r_c/r_w	0.5
B/B _g	0.99
$\Delta v_z/v_z$	5%
Number of Sections	3
Section Length	3.78 cm
Circuit Length	14.2 cm

Table 6. Design Parameters for Proposed 95 GHz Three-Cavity, Third-Harmonic Smooth-Bore TE₃₁₁ Gyro-Klystron Amplifier with Axis-Encircling Beam.

Beam Voltage	70 kV
Beam Current	5 A
$\alpha (= v_{\perp}/v_z)$	2.0
Frequency	95 GHz
Magnetic Field	12.4 kG
Mode	TE ₃₁₁
Cyclotron Harmonic	3
Cavity Radii, r_w	0.21 cm
Cavity Lengths	1.26 cm
Cavity Q's	200 (1, 2); 300 (3)
Drift Tube Lengths	1.26 cm
$\Delta r_c/r_w$	10%
$\Delta v_z/v_z$	10%