



US Army Corps of Engineers
Water Resources Support Center
Institute for Water Resources



US Army Corps of Engineers
Waterways Experiment Station

PROTOTYPE INFORMATION TREE
FOR ENVIRONMENTAL
RESTORATION
PLAN FORMULATION
AND
COST ESTIMATION

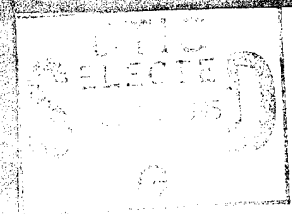
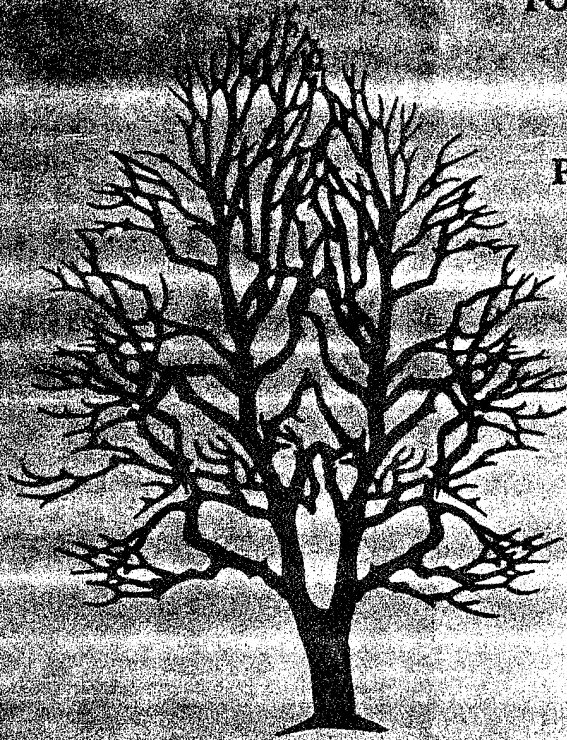

19950712 026

Evaluation of Environmental Investments Research Program

March 1995

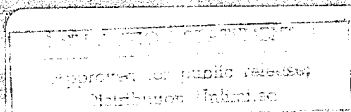

IWR Report 95-R-3

PROTOTYPE INFORMATION TREE FOR ENVIRONMENTAL RESTORATION PLAN FORMULATION AND COST ESTIMATION

by

Paul F. Scodari
Curtis C. Bohlen
Amal Srivastava

of

King and Associates, Inc.
1616 P Street, N.W.
Washington, D.C. 20036

for

U.S. Army Corps of Engineers
Water Resources Support Center
Institute for Water Resources
Alexandria, VA 22315-3868

U.S. Army Corps of Engineers
Waterways Experiment Station
Vicksburg, MS 39180-6199

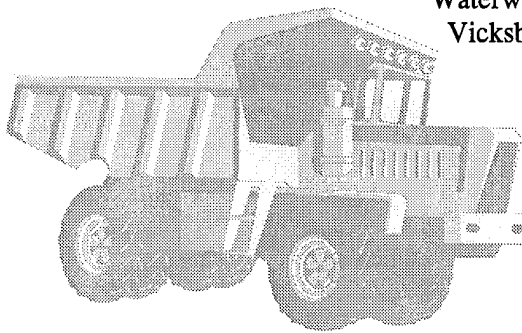
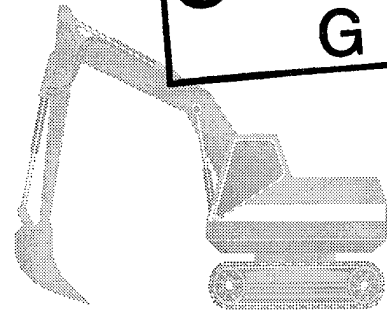
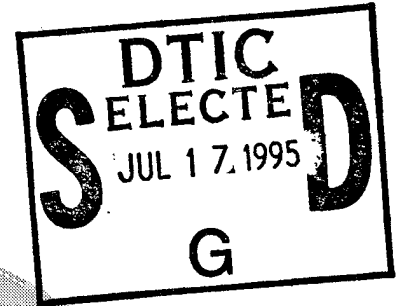

Accession For	
NTIS CRA&I	<input checked="" type="checkbox"/>
DTIC TAB	<input type="checkbox"/>
Unannounced	<input type="checkbox"/>
Justification _____	
By _____	
Distribution / _____	
Availability Codes	
Dist	Avail and/or Special
A-1	

DTIC QUALITY INSPECTED 5

Evaluation of Environmental
Investments Research Program

DISTRIBUTION STATEMENT A
Approved for public release;
Distribution Unlimited

IWR Report 95-R-3
March 1995

*Prototype Information Tree for Environmental
Restoration Plan Formulation and Cost Estimation*

PREFACE

This work reported herein was conducted as part of the Evaluation of Environmental Investments Research Program (EEIRP). The EEIRP is sponsored by the Headquarters, U.S. Army Corps of Engineers (HQUSACE). It is jointly assigned to the U.S. Army Engineer Water Resources Support Center (WRSC), Institute for Water Resources (IWR) and the U.S. Army Engineer Waterways Experiment Station (WES), Environmental Laboratory (EL). Mr. William J. Hansen of IWR is the Program Manager and Mr. H. Roger Hamilton is the WES Manager. Program Monitors during this study were Mr. John W. Bellinger and Mr. K. Brad Fowler, HQUSACE. The field review group members that provide overall Program direction and their District or Division affiliations are: Mr. David Carney, New Orleans; Mr. Larry M. Kilgo, Lower Mississippi Valley; Mr. Richard Gorton, Omaha; Mr. Bruce D. Carlson, St. Paul; Mr. Glendon L. Coffee, Mobile; Ms. Susan E. Durden, Savannah; Mr. Scott Miner, San Francisco; Mr. Robert F. Scott, Fort Worth; Mr. Clifford J. Kidd, Baltimore; Mr. Edwin J. Woodruff, North Pacific; and Dr. Michael Passmore, Walla Walla.

This report is a part of the Engineering Environmental Investments - Formulating Inputs and Monitoring Effectiveness work unit of EEIRP. The objectives of this work unit are to: 1) identify relevant approaches and features for environmental investment measures to be applied throughout the project life; 2) develop methods to access the effectiveness of the approach or feature for providing the intended environmental output; 3) develop and provide guidance for formulating environmental projects; and 4) provide guidance for formulating and identifying relevant cost components of alternate restoration plans.

This report focuses on three specific objectives: 1) Developing a prototype information tree structure to provide and organize data and information useful for environmental restoration plan formulation and cost estimation; 2) Describing the content of the tree branches and their linkages; and 3) Beginning the process of building the tree database, and identify additional data sources and data deficiencies with respect to its more complete implementation. Other efforts under this research program's work unit will be built into this prototype information tree database. These efforts include investigating environmental type management measures developed by the Corps as well as non-Corps agencies and a more detailed examination of cost measures by the Corps and non-Corps agencies.

This report describes the conceptual development of an information tree to assist in the design of environmental restoration projects. Before devoting significant resources to more fully develop the concept for implementation, it was considered necessary to obtain field input as to its potential usefulness, desirable features, and potential final format. Interim copies of this report were therefore sent to all District and Division Chiefs of Planning and Engineering, to solicit their

***Prototype Information Tree for Environmental
Restoration Plan Formulation and Cost Estimation***

views and comments or those of their staff. The specific questions they were asked, and a summary of their responses are summarized below.

To date, thirty-nine (39) total responses have been received from thirty (30) Districts and nine (9) Divisions. Approximately 65 percent of these responses were from Planning Division and 35 percent were from Engineering Division.

Question 1. Do you perceive a need or see a usefulness of the overall concept to the Information Tree? Is the Information Tree worth pursuing? Over 80 percent indicated a positive response to these set of questions. Comments most frequently noted included that the information tree would be especially useful for new employees or to employees not yet familiar with environmental restoration planning. Of those that didn't consider this effort worth pursuing, the most frequently noted comments included that the information tree was too general or simplistic, any knowledgeable planner should know all this information, and any person working on such a tool should not be working alone on these types of projects.

Question 2. Is the general structure of the tree easy to follow? Are the resource types appropriate? Are the branches appropriate? Should there be more or less branches? Approximately 80 percent indicated a favorable response in regards to the general structure, resource types and the branches of the information tree. Some of the most frequent negative comments included that the structure was confusing at times, complicated and difficult to follow, branches could be renamed, and call it something else besides a tree.

Question 3. Are the types of information sources in the specific cells appropriate? Useful? Approximately 85 percent indicated that the information sources were appropriate and useful. Many noted that this is a conceptual design, and as this effort becomes more detailed, then the information will become more useful. There were suggestions on listing completed projects with background information, and there were some concerns on getting better cost information.

Question 4. How would you like to see the final format of the information tree? (i.e., hard copy - loose leaf notebook, supporting software, other ideas?). Nearly 85 percent of the responses suggested using the hard copy - loose leaf notebook format. A large number of this percentage suggested the hard copy with supporting software. The remaining respondents suggested using expert systems.

Overall, there was a favorable response in terms of the usefulness of the proposed information tree. However, there was some disagreement as to the structure, types of information and final format this effort should take. The next steps taken in this effort will be to incorporate information from existing Corps environmental studies and non-Corps environmental studies

*Prototype Information Tree for Environmental
Restoration Plan Formulation and Cost Estimation*

along with a more detailed examination of environmental cost information and monitoring efforts. Also, in the near future, a working group will be convened in order to apply the information tree to environmental studies and see in reality how it will work, what other information is needed, and other observations.

If there are any questions or comments in regards to this report, feel free to contact either Ms. Joy Muncy (703) 355-0009 or Mr. William Hansen (703) 355-3089 or Fax # (703) 355-8435 at IWR.

This report was prepared by King and Associates, Inc. Under terms of a contract with the U.S. Army Engineer, IWR; Ms. Joy Muncy was the Contract Manager. This report was prepared under the general supervision of Mr. Michael R. Krouse, Chief, Technical Analysis and Research Division, IWR; and Mr. Kyle Schilling, Director, IWR.

At the time of preparation of this report, Mr. Kenneth H. Murdock was Director of WRSC.

*Prototype Information Tree for Environmental
Restoration Plan Formulation and Cost Estimation*

TABLE OF CONTENTS

PREFACE	iii
TABLE OF CONTENTS	vii
INTRODUCTION	1
Purpose and Scope	1
General Approach	2
Plan of Report	3
I. ROOTS OF THE INFORMATION TREE	5
Broad Problem Areas	7
Linking Habitat Deficiencies with Broad Problems	10
II. INFORMATION TREE STRUCTURE AND CONTENT	17
Main Stem and Branches	17
Summary Information Modules	19
III. PRELIMINARY IMPLEMENTATION	21
Information Trees	21
Summary Information Modules	43
IV. FURTHER IMPLEMENTATION NEEDS	45
General Needs	45
Presentation Format	46
GLOSSARY	49
REFERENCES AND SOURCES OF ADDITIONAL INFORMATION	51

List of Figures

Figure 1 - Example HEP Model Analysis	6
Figure 2 - Structure of Prototype Information Tree: Example for Lakes and Ponds	18

*Prototype Information Tree for Environmental
Restoration Plan Formulation and Cost Estimation*

List of Tables

Table 1a.	Lakes and Ponds: Target Variables Likely to Be Identified as Deficient in HEP Models, Linked to Broad Ecosystem Problem Areas	11
Table 1b.	Rivers and Streams: Target Variables Likely to Be Identified as Deficient in HEP Models, Linked to Broad Ecosystem Problem Areas	12
Table 1c.	Wetlands: Target Variables Likely to Be Identified as Deficient in HEP Models, Linked to Broad Ecosystem Problem Areas	14
Table 2.	Restoration Information Tree for Lakes and Ponds	22
Table 3.	Restoration Information Tree for Rivers and Streams	25
Table 4.	Restoration Information Tree for Non-tidal Wetlands	28
Table 5.	Restoration Information Tree for Tidal Wetlands	33
Table 6.	Techniques for Restoring Lakes and Ponds: Summary Information Modules	37

INTRODUCTION

Environmental restoration is the process of rehabilitating and repairing degraded ecosystems. As defined by the U.S. Army Corps of Engineers (USACE), the purpose of environmental restoration is to "improve the condition of a disturbed ecosystem, including its plant and animal communities, or portions thereof, to some prior ecological condition" (USACE, 1994).

Recent congressional authorities and policy developments have placed increased emphasis on USACE efforts directed toward environmental restoration. The USACE has determined that this will require improvements in the methods and techniques for developing and evaluating environmental restoration projects and programs. To help fill this need, the USACE initiated the "Evaluation of Environmental Investments Research Program" (EEIRP), which includes a variety of related research efforts.

This report presents the results of one small part of the EEIRP aimed at developing an information base to support plan formulation and cost estimation for environmental restoration projects in aquatic ecosystems. Plan formulation refers to the development of alternative ways to accomplish project-specific restoration objectives. It focuses on the process by which project planners identify alternative restoration measures and techniques which could be undertaken to promote project goals at the project site.

Purpose and Scope

The formulation of environmental restoration plans for some project site requires a large amount of data and information on a wide variety of relevant factors and variables. In an effort to simplify the data gathering task faced by restoration planners, this report investigates the possibility of developing an informational tool for organizing and providing the type of data and information necessary for identifying and costing restoration measures and techniques. The specific objectives of the report include:

1. Develop a prototype information tree structure to provide and organize data and information useful for environmental restoration plan formulation and cost estimation;
2. Describe the content of the tree branches and their linkages, and;
3. Begin the process of building the tree database, and identify additional data sources and data deficiencies with respect to its more complete implementation.

***Prototype Information Tree for Environmental
Restoration Plan Formulation and Cost Estimation***

The investigation of alternative tree structures proceeded from the premise that, to be useful for restoration planners, the tree should include certain linked information categories or "levels" which reflect the various steps required to complete the plan formulation and cost estimation process. Accordingly, the information tree structure and content should:

1. Identify the environmental variables that need to be manipulated to promote project goals (i.e. target variables),
2. Link target variables with broad management approaches that could be used to manipulate them,
3. Link broad management approaches with more specific management measures and techniques for their implementation,
4. Identify the major engineering features or components associated with alternative management techniques, and
5. Provide information that will help project planners to estimate the costs of management techniques and to identify their potential effectiveness and ancillary ecological and other effects.

General Approach

The development and illustration of the information tree structure and content involved several discrete tasks. The first involved a search of the published literature and in-house files for information on the various techniques most commonly used for the restoration of aquatic ecosystems. The database developed from this search revealed that restoration techniques vary considerably according to the type of aquatic ecosystems to be restored (e.g. flowing water systems versus standing water systems). Consequently, it was decided that separate trees would need to be developed for each of four types of aquatic ecosystems: (1) Lakes and ponds, (2) Rivers and streams, (3) Non-tidal wetlands, and (4) Tidal wetlands.

The second task involved examining the various environmental assessment techniques used by project planners to identify site deficiencies with respect to project goals. It focused on developing the "roots" of the tree which link the results of environmental assessments (i.e. target variables) with the main stem.

The next task involved an investigation of the various ways that the information tree for each of the four ecosystem types could be structured, and the types of data the tree branches should include. A primary consideration for developing the tree structure was how site-specific

*Prototype Information Tree for Environmental
Restoration Plan Formulation and Cost Estimation*

factors might be reflected in the various tree branches. The remaining tasks began the process of filling in the tree branches with data and citations to additional information to preliminarily implement the tree and illustrate its potential usefulness for project plan formulation and cost estimation.

Plan of Report

The remainder of the report is divided into four sections. The first describes the linkage between target variables and the main stem of the tree. The second section outlines and describes the tree structure, and reviews the content of the various branches and their linkages. The third describes the preliminary implementation of the tree structure for the different ecosystem types, and the final section discusses further work needed to more fully develop and implement the restoration tree concept.

I. ROOTS OF THE INFORMATION TREE

The development and analysis of restoration plans requires as a starting point recognition of the deficient environmental variables at the site that the restoration project is intended to address. Site deficiencies in environmental variables may be identified through the use of a variety of environmental assessment techniques. While at least three broad assessment philosophies can be identified among existing assessment tools, the habitat-based approaches are the type most commonly used for restoration planning. The U.S. Fish and Wildlife Service's "Habitat Evaluation Procedure" (HEP) represents one commonly used habitat-based assessment technique. HEP models utilize "Habitat Suitability Indexes" to identify and evaluate sites against habitat requisites for one or more resident fish and wildlife species.

Figure 1 provides a hypothetical HEP model application to identify deficient environmental variables with respect to fish habitat requirements at some site. The roots of the information tree must be able to link the types of environmental variables identified as deficient by environmental assessment techniques with the main stem of the information tree. This is complicated because, in general, the identification of target variables will be insufficient to uniquely identify appropriate restoration approaches. At best, the list of target variables generated from an environmental assessment protocol can be only loosely linked, a priori, to specific restoration approaches.

Most habitat deficiencies can be addressed in a variety of ways, and it is seldom very useful to try to treat a single deficient habitat variable in isolation. The set of deficient habitat variables identified must therefore be examined together in light of what is known about broader ecological conditions at the site, and the specific goals and constraints of the restoration project under consideration, in order to determine appropriate ways to proceed. Habitat deficiencies are often symptoms of broader ecological problems that usually can and should be addressed in order to achieve project goals. In particular, the overall pattern of habitat deficiencies provides information valuable for the identification of broad themes that the restoration effort should address.

Human activity degrades ecosystems in a few, relatively stereotypical, ways. These commonalities suggest that the majority of environmental restoration projects will address similar environmental problems and will focus on a relatively small number of well understood changes in ecosystems precipitated by human activity. For example, aquatic systems degraded by human activity upstream typically show reduced dissolved oxygen levels, increased concentrations of major plant nutrients, and altered hydrologic conditions. Those anthropogenic impacts may secondarily degrade specific habitat requisites for desired animal plant species, or result in changes in habitat structure and function that will be revealed by HEP model analyses.

Prototype Information Tree for Environmental Restoration Plan Formulation and Cost Estimation

Habitat Units	Habitat Suitability	Example Life Requisites	Example Habitat Variables	Deficient Habitat Variables?
	HSI	Water Quality	V ₁ (<i>dissolved oxygen</i>)	-- Yes
			V ₂ (<i>turbidity</i>)	-- No
		Cover	V ₃ (<i>% vegetation cover</i>)	-- No
			V ₄ (<i>% pools</i>)	-- No
HU		Habitat Area	V ₅ (<i>total area</i>)	-- Yes

Figure 1 - Example HEP Model Analysis

Prototype Information Tree for Environmental Restoration Plan Formulation and Cost Estimation

Restoration planning efforts should therefore begin not just with the identification of site target variables, but also with the recognition of the central importance for the restoration effort of addressing one or more broad patterns of environmental decline. This pattern is so pervasive that the information tree has been organized around themes of environmental decline. Entry into the information tree is based on:

1. Specification of the broad type of ecosystem to be restored (Lakes and Ponds, River and Streams, Non-tidal Wetlands, or Tidal Wetlands) and,
2. Identification of the broad environmental problem areas to be addressed at the project site.

Broad Problem Areas

The information tree has been structured around four broad problem areas that reflect the majority of environmental restoration scenarios likely to be encountered in practice. Restoration projects could include aspects from more than one of these themes, but depending on site-specific characteristics and the goals of the environmental restoration project, one or another of the problem categories may predominate. The four problem areas include:

1. Eutrophication (Organic pollution and low dissolved oxygen)

The effects of an excess of non-refractory organic matter on aquatic ecosystems is well known. Organic matter fuels high levels of microbial respiration and biomass, which in turn reduce dissolved oxygen levels. Hypoxic, anoxic, and even anaerobic conditions are produced that are deadly to most multi-cellular life. Mobile organisms may evade low oxygen conditions, and thus be exposed to more dangerous, more stressful, or less abundant existence elsewhere. Most sessile organisms simply die. Low dissolved oxygen conditions are, for most multicellular life, one of the biggest threats to habitat quality. While untreated or poorly treated sewage may be the most widespread direct source of non-refractory organic pollution in most aquatic ecosystems, industrial effluents, runoff from animal production facilities and runoff from roads and parking lots are also major contributors.

Many aquatic ecosystems are degraded by the presence of excess organic matter produced within the ecosystem itself. The organic matter is produced by in-situ production triggered by high availability of nutrients, often from anthropogenic sources. Excess nutrients fuels the growth of plants, especially planktonic and epiphytic algae. If eutrophication is not too advanced, the nutrients may also encourage the growth of aquatic plants (macrophytes), which may reach nuisance levels. Eventually, the plants and algae die, producing high levels of organic matter

***Prototype Information Tree for Environmental
Restoration Plan Formulation and Cost Estimation***

within the system, which can trigger declines in the availability of oxygen similar to those triggered by organic pollutants.

Several interrelated variables, from chlorophyll A concentrations in the water column to dissolved oxygen concentrations to percent cover of submerged aquatic plants, change in predictable ways as concentrations of nutrients and organic matter within aquatic ecosystems change. Any change in nutrient concentrations tends to affect many ecosystem variables simultaneously. Recognition that the problem one faces is essentially one of low dissolved oxygen, eutrophication, or nutrient enrichment can therefore suggest effective solutions.

2. Hydrologic Alteration

Many river and stream environments are degraded by the imposition of a hydrologic regime to which the system is neither dynamically nor evolutionarily accustomed. Agricultural development, urbanization and suburbanization typically increase surface runoff and decrease percolation of water from precipitation into unconfined surface aquifers, thus increasing flood peaks and decreasing base flows. These changes in stream hydrology in turn alter sediment transport properties, increasing erosion and redeposition of sediments within the stream. The erosion may take several forms, including down-cutting of stream beds which isolates the stream system from its floodplain, and lateral shoreline erosion which can threaten adjacent land uses in the short term and eventually produce shallow, often braided streams with high water temperatures and poor aquatic habitat.

Still-water habitats can also be degraded by hydrologic changes. Species diversity within the vegetation of wetlands, lake shores, and shallow water habitats is frequently reduced by the imposition of hydrologic regimes that only the most robust aquatic plant species can survive.

3. Sedimentation

High rates of sedimentation have profound effects on stream and river ecosystems. Deposition of sediments within stream channels clog gravel and cobble areas with fine sediments, reducing the suitability of the stream bottom for spawning of fish and as refuge for benthic invertebrates. Sedimentation also reduces the cross-sectional area of the stream channel, thus increasing the frequency of erosive "bankfull" flow conditions and overbank flooding. At times, this can result in feedback effects whereby relatively small sediment inputs lead to substantial erosion of the stream banks and much larger sediment deliveries downstream as sedimentation destabilizes the stream bottom and banks. Sediments can smother benthic organisms, or reduce the feeding efficiency of filter feeders, further degrading aquatic habitats.

*Prototype Information Tree for Environmental
Restoration Plan Formulation and Cost Estimation*

In still-water systems, sedimentation has many similar effects. It tends to reduce water depths, reduce heterogeneity in bottom topography (thus decreasing habitat diversity), and smother benthic organisms. In addition, sediments often carry nutrients and toxic compounds into lakes, ponds, and wetlands.

4. Habitat Alteration

Habitat alteration represents the final broad category of environmental problem around which the information tree has been structured. To a large extent, the three problem categories described above can all be understood as habitat alteration. However, a closer look at habitat issues reveals a number of direct structural changes in habitats that typically follow human-induced environmental change. In general, human activity reduces the structural complexity of both aquatic and terrestrial habitats. It replaces gradual ecotones (transitions between habitat types) with abrupt ones. Relationships between adjacent habitats are disrupted. Large contiguous habitat areas are often fragmented.

In rivers and streams, complex sinuous channels with alternating riffle and pool areas are often replaced by simpler, less meandering confined channels of more constant water depth and velocity. The area of floodplain that is allowed to be flooded may be reduced, either intentionally or unintentionally, severing stream-floodplain dynamic relationships. Dams and other barriers to the migration of aquatic organisms may isolate populations of fish within stream reaches. The naturally complex physical structure of boulders, snags, bars, and woody debris is typically much simplified. Shoreline habitat complexity is often reduced where riparian vegetation has been altered.

In still-water systems, diversity of habitats is often reduced by sedimentation, which levels wetland topography and the bottom contours of lakes. Structural complexity may also be simplified as woody debris and other components of habitat structure are removed or simply no longer replaced by natural processes.

Habitat changes present distinct problems for ecosystem restoration and management, because one must understand how the structure and complexity of habitats have been altered by human activity in order to prescribe appropriate restoration approaches. For example, the widespread use of wood duck boxes in wooded wetlands in the eastern United States replaces a specific habitat component—standing dead trees with holes—that are far less common in logged-over, disturbed, and successional young wetlands than in older, less altered wetland forests.

***Prototype Information Tree for Environmental
Restoration Plan Formulation and Cost Estimation***

Linking Habitat Deficiencies with Broad Problems

Tables 1a through 1c list the various environmental variables commonly found to be deficient in lakes and ponds, rivers and streams, and wetlands, respectively. Each deficiency is linked to one or more broad problems to which it is often related (which in the tables are labeled Eutrophication, Sedimentation, Hydrology, and Habitat). For example, Table 1a links habitat deficiencies with respect to dissolved oxygen levels to the broad problem category labeled eutrophication.

These tables are the roots of the information tree which link identified habitat deficiencies with the main stem through the broad problem areas outlined above. The information tree has been structured around these broad problem areas. To identify where on the main stem to enter the information tree for some ecosystem type, the user would use Tables 1a-1c to match information on the habitat deficiencies at the project site with one or more of the broad problem areas to which they are related.

Tables 1a-1c show that the various ecosystem types typically become the focus of environmental restoration efforts for somewhat different reasons. Wetlands typically are the focus of efforts to repair hydrologic problems, often triggered by drainage. Of course, establishment of desired vegetation types is also a frequent goal of wetland restoration. But since wetland vegetation is highly sensitive to hydrologic conditions, the key restoration effort is often hydrological in nature.

Restoration of lakes and ponds is generally undertaken because of fish kills, deterioration of fisheries, appearance of nuisance plant or algal growth, or rapid shoaling of the basin. Problems with eutrophication and sedimentation therefore predominate. Habitat concerns and general hydrologic considerations play a subsidiary role.

Rivers and streams are typically the target of restoration efforts because of hydrologic modifications, changes in sediment loadings, or channelizations that have moved target stream reaches away from geomorphic equilibrium. Hydrological and sediment problems predominate, but habitat creation and restoration may also be important.

Information on ecosystem type and pattern of environmental decline is used as a bridge to connect identified site deficiencies with the main stem of the ecosystem-specific information trees. It is used as a convenient way to organize the trees, but should not be taken too literally. From an ecological perspective, no fast boundary exists among aquatic ecosystem types. Many reservoirs and floodplain lakes have both lake-like and river-like characteristics. Shallow lakes are remarkably like wetlands, and wetlands may take on pond-like characteristics. And the broad problem areas also overlap. For example, changes in the hydrologic conditions of almost any

*Prototype Information Tree for Environmental
Restoration Plan Formulation and Cost Estimation*

TABLE 1a. LAKES AND PONDS: Target Variables Likely to be Identified as Deficient in HEP Models, Linked to Broad Ecosystem Problem Areas

Deficient Target Variables	Typical Deficiency	Typical Causes of Deficiency	Broad Problem Area
Dissolved Oxygen	Low oxygen concentrations	High organic matter from untreated sewage, high productivity.	Eutrophication
Turbidity	Too turbid	Fine sediments in water.	Sedimentation/ Hydrology
	Too turbid	Abundant phytoplankton, nutrient enrichment.	Eutrophication
Primary Productivity	Too productive	Nutrient enrichment, typically from sewage, runoff, or industrial effluents.	Eutrophication
Nitrogen And Phosphorus Loading Or Concentration	Too abundant	High values typically from sewage treatment plants, urban and agricultural runoff, atmospheric inputs.	Eutrophication
Submersed Aquatic Plants	Too many	Nutrient enrichment.	Eutrophication
	Too few	Abundant phytoplankton and epiphytic algae.	Eutrophication
	Too few	Non-algal turbidity.	Sedimentation/ Hydrology
Water Depth	Too shallow	Sediment inputs, new impoundments.	Sedimentation/ Hydrology
Sediment Quality	No coarse substrates	Sediment inputs from upstream flowing water.	Sedimentation/ Hydrology
Structural Habitat for Fish	Too little structure	Abnormal shoreline morphology, little shoreline vegetation.	Habitat

**Prototype Information Tree for Environmental
Restoration Plan Formulation and Cost Estimation**

TABLE 1b. RIVERS AND STREAMS: Target Variables Likely to be Identified as Deficient in HEP Models, Linked to Broad Ecosystem Problem Areas

Deficient Target Variables	Typical Deficiency	Typical Causes of Deficiency	Broad Problem Area
Dissolved Oxygen	Too low	High organic matter from untreated sewage, high productivity, low oxygen inputs.	Eutrophication
Primary Productivity	Too high	Nutrient enrichment.	Eutrophication
Nitrogen and Phosphorus Loading/ Concentration	Too high	High values typically from sewage treatment plants, urban and agricultural runoff, atmospheric inputs.	Eutrophication
Aquatic Plants	Too many	Nutrient enrichment.	Eutrophication
	Too few	Abundant phytoplankton and epiphytic algae.	Eutrophication
	Too few	Non-algal turbidity.	Sedimentation/ Hydrology
Turbidity	Too high	Abundant fine sediments in the water column.	Sedimentation/ Hydrology
Riffle-Pool Patterns	Poorly developed or not present	Channelized streams, heavy sediment inputs, hydrologic alteration.	Sedimentation/ Hydrology
Sinuosity	Not as sinuous as expected	Channelized streams, heavy sediment inputs, hydrologic alteration.	Sedimentation/ Hydrology
Water Depth	Too shallow too even	Sedimentation, hydrologic alterations.	Sedimentation/ Hydrology
Storm Hydrograph	Too "Flashy"	Loss of wetlands, forest, riparian buffers, increase in impervious surfaces, stormwater conveyances.	Sedimentation/ Hydrology
Watershed Imperviousness	High Imperviousness	Urban or suburban development upstream.	Sedimentation/ Hydrology

*Prototype Information Tree for Environmental
Restoration Plan Formulation and Cost Estimation*

TABLE 1b. RIVERS AND STREAMS: Target Variables Likely to be Identified as Deficient in HEP Models, Linked to Broad Ecosystem Problem Areas

Deficient Target Variables	Typical Deficiency	Typical Causes of Deficiency	Broad Problem Area
Sediment quality	Silts and clays predominate, larger fractions "embedded"	Increased Sediment Loads, Construction of Reservoirs on stream with high natural sediment loads.	Sedimentation/ Hydrology
Shoreline condition	Poorly defined channel, little shoreline vegetation, etc.	Flashy hydrology, animals or humans with regular access to stream bank.	Sedimentation/ Hydrology
Cover for Fish and invertebrates	Too little	Clearing of woody debris, reduced stream bank vegetation.	Habitat
	Too little	Poor stream bank development, few undercut banks, little spatial variation in water flow, etc.	Sedimentation/ Hydrology
Stream blockages	Too abundant	Various.	Habitat

**Prototype Information Tree for Environmental
Restoration Plan Formulation and Cost Estimation**

TABLE 1c. WETLANDS: Target Variables Likely to be Identified as Deficient in HEP Models, Linked to Broad Ecosystem Problem Areas				
Broad Wetland Type	Deficient Target Variables	Typical Deficiency	Typical Causes of Deficiency	Broad Problem Area
Nontidal Wetlands	Invasive Vegetation	Abundant	Hydrologic alteration, removal of surface litter and existing vegetation.	Hydrology
			Nutrient enrichment.	Eutrophication
			Previous removal of surface litter and existing vegetation.	Habitat
	Undesired Vegetation Type	Various	Flooding depth or frequency inappropriate for desired species.	Hydrology
	Total Vegetation Cover	Too low	Low soil nutrients, inappropriate hydrology	Hydrology
Tidal Wetlands	Invasive Vegetation	Abundant	Hydrologic alteration, nutrient enrichment, removal of surface litter and existing vegetation.	Habitat, Hydrology, Eutrophication
			Flooding depth or frequency inappropriate for desired species.	Hydrology
			Low soil nutrients, inappropriate hydrology.	Hydrology

*Prototype Information Tree for Environmental
Restoration Plan Formulation and Cost Estimation*

aquatic environment will affect sediment and habitat conditions. Interconnections between site deficiencies and broad problems should be expected. They are part of the rich structure of natural systems, and present both problems and opportunities for restoration planners.

II. INFORMATION TREE STRUCTURE AND CONTENT

Figure 2 presents an overview of the basic structure and content of the information tree for environmental restoration. The first column presents the first tier of the tree structure which can be viewed as the main stem. It provides information relating to the various broad management approaches that might be used to address broad problem areas.

The next three columns can be viewed as the branches of the tree. The first branch (the one linked directly to the main stem) provides information on more specific management measures that could be used to advance some broad management approach. The second branch provides information on the specific management techniques that could be used to implement some management measure, and the third branch describes the major engineering features of those techniques.

The last column of Figure 2 labeled "summary information modules" can be viewed as the leaves on the tree branches relating to specific management techniques. They provide summary information on each technique, including applicability and effectiveness, means and costs to implement, and potential ancillary ecological and other effects.

Main Stem and Branches

Figure 2 uses the example of eutrophication problems in lakes and ponds to illustrate the types of information the tree stem and branches would provide. Entrance into the main stem of the tree requires that the user first link those habitat variables identified as deficient at the project site with one or more of the broad problem areas to be addressed by the restoration project. This process was described in the previous section as tracing through the roots of the information tree. For example, if a HEP analysis at a lake restoration site identifies habitat deficiencies with respect to low dissolved oxygen levels in summer and related water quality problems, the tables presented in the previous section would guide the user to enter the tree for lakes and ponds through that part of the main stem that deals with eutrophication problems.

As described in the previous section, the process of linking deficient habitat variables to one or more broad problem areas is necessary to guide the tree user to that part of the ecosystem-specific tree most relevant for their particular project application. But this process would be insufficient, by itself, to indicate the appropriate management approach(es) for some site. Figure 2 identifies four broad management approaches for addressing eutrophication problems in lakes and ponds. In order to determine which of these approaches might be best suited for addressing the habitat deficiencies in the above example, the project planner would need to consider each of

Prototype Information Tree for Environmental Restoration Plan Formulation and Cost Estimation

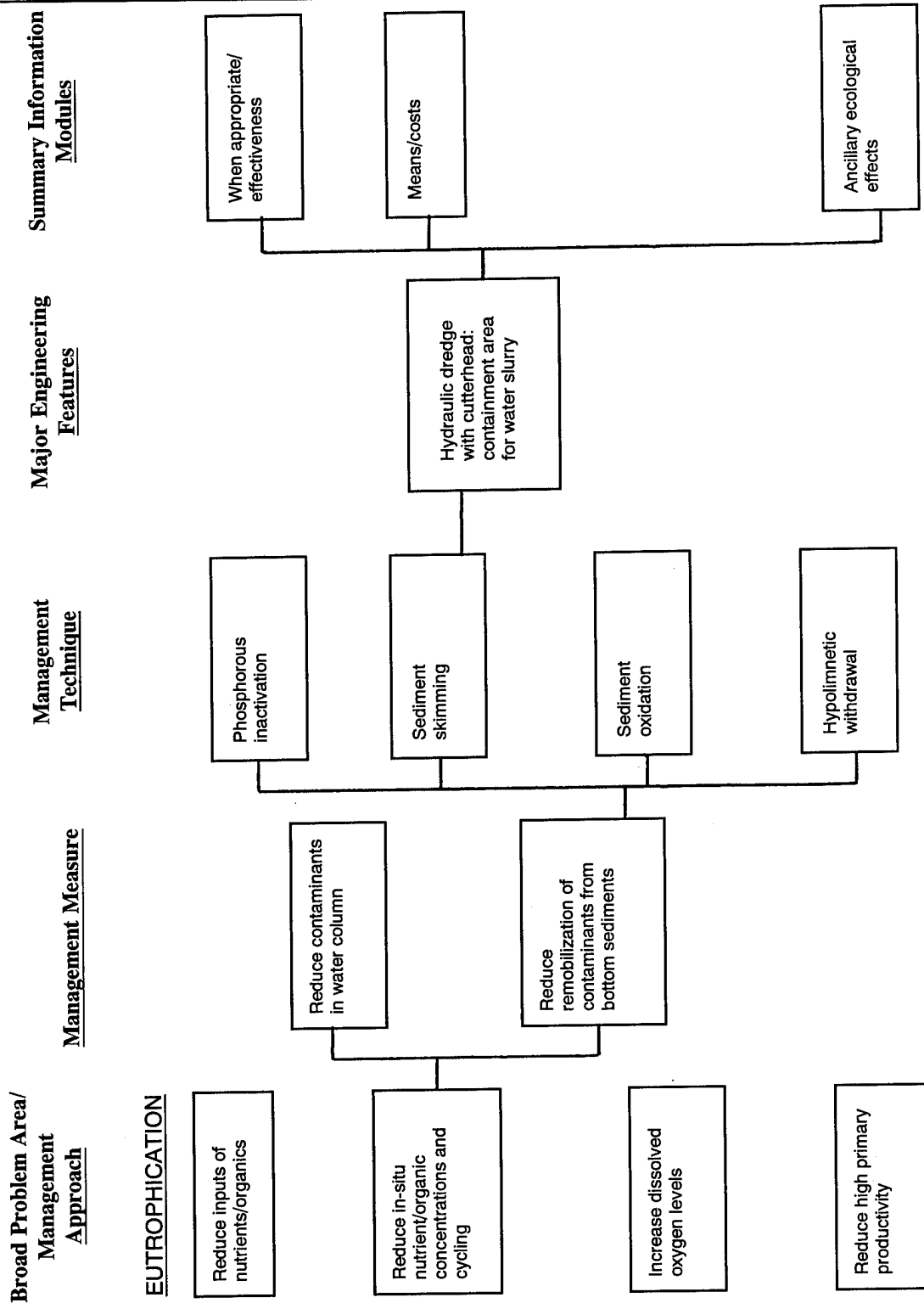

Figure 2 - Structure of Prototype Information Tree: Example for Lakes and Ponds

*Prototype Information Tree for Environmental
Restoration Plan Formulation and Cost Estimation*

these alternatives in light of broader site factors and the specific goals and constraints of the restoration project.

In Figure 2, the second branch of the tree identifies two management measures associated with one particular management approach to reduce in-situ nutrient concentrations and cycling. For one of these measures, to reduce the remobilization of nutrients from bottom sediments, the figure shows four available management techniques. The fourth branch of the tree then provides a general list of the major engineering features associated with one of four technical options--sediment skimming--for reducing the remobilization of nutrients from bottom sediments.

Figure 2 illustrates that the prototype information tree has been designed to provide project planners with a hierarchal menu of general to more specific restoration options. The information it provides on management approaches, measures, and techniques implicitly includes some very general information relating to site factors. For example, the management approach in Figure 2 labeled "reduce inputs of nutrients/organics" assumes that loadings of these pollutants may be an underlying cause of eutrophication problems at some project sites. But the choice of a management approach for addressing some problem area, and for moving from the main stem through the tree branches to identify appropriate management measures and techniques, will require considerable judgement on the part of project planners in consideration of a much broader range of more specific site factors and characteristics (as well as project goals and constraints).

In the development of the tree structure, we investigated how general variations in site factors might be included directly within the tree structure as connecting branches to help users to identify restoration scenarios most appropriate for their particular situations. This examination concluded that the addition of more specific site factors directly within the tree structure would greatly increase the complexity of the tree without adding appreciably to its utility for project planners. Instead, it was decided that the place for more specific information on site factors was the summary information modules provided for each management technique.

Summary Information Modules

The summary information modules shown by the three boxes in the last column of Figure 2 are designed to provide summary information on management techniques. The first module would provide data and sources of additional information on the general site conditions to which a particular management technique would be most applicable, and information on the technique's likely effectiveness for promoting specific project goals. It would discuss, for example, the types of site characteristics which determine the suitability of the management technique; the scale at which the technique must be applied in order to show results; and the likely effectiveness of the technique in the short term and long term, and how these results compare to those that might be expected through the use of other available management techniques. This module would also

***Prototype Information Tree for Environmental
Restoration Plan Formulation and Cost Estimation***

ideally cite to published literature on particular case examples that utilized and reported on the effectiveness of the technique.

The second information module would provide data and sources of additional information on the means and costs of implementing management techniques. The term "means" refers information on how to implement some technique, including information on the various inputs associated with the technique's major engineering features and component tasks. Ideally, the data and information provided on means and costs would include:

- 1) The type of each input needed (e.g. equipment, labor, materials) and the timing of its application (e.g. initial, annual, periodic);
- 2) The units (e.g. number, labor hours) of each input required to implement the management technique at various scales (e.g. quantity, frequency, intensity), and;
- 3) Average unit costs for each input.

If this module could provide data to this level of detail, it would provide project planners with the raw material needed to estimate the site-specific costs associated with implementing management techniques. But since this may not be possible in most cases, second best informational options may need to be pursued. These might include, for example, well-documented project cost estimates for specific applications reported in the literature, and qualitative information on the relative costs of techniques.

The final information module is designed to include general information on the ancillary effects of management techniques, such as ancillary ecological effects, both positive and negative. An example of the latter would be toxicity to non-target species associated with the application of algicide to a lake for the control of nuisance algae. On the positive side, many bio-engineered approaches to stream restoration produce ancillary benefits. For example, willow stakes planted to reduce stream bank erosion also provide riparian vegetation that shades and supplies organic inputs to streams, thereby enriching the local biota and contributing to water quality.

III. PRELIMINARY IMPLEMENTATION

In order to illustrate the information tree, a preliminary effort was made to implement the basic structure for each of the four broad ecosystem types: (1) Lakes and ponds, (2) Rivers and streams, (3) Non-tidal wetlands, and (4) Tidal wetlands. These are provided in Tables 2-5. An effort was also made to begin the process of implementing the summary information modules by focusing on partially implementing those associated with the tree for lakes and ponds, which is presented in Table 6.

Information Trees

The tree structure described in Figure 2 was used for implementing trees for each of the four ecosystem types. While the basic structure remains constant across each, differences in the natural structures and processes of the ecosystem types suggest some variation in the appropriate interpretation and use of the various trees. This is explained more fully below.

1. Lakes and Ponds

Interpretation and use of the information tree developed for lakes and ponds is perhaps the most straightforward of the four ecosystem-specific trees due to the particular characteristics of standing-water ecosystems. Lake and pond systems generally have long water residence times, well-defined physical boundaries, and (at least within temperate lakes) relatively homogenous and well-understood physical structures. Restoration efforts are generally focused on problems that affect whole lakes or relatively large regions within lakes, including high primary productivity, sedimentation, low dissolved oxygen, or excess algal or plant growth. Because of the large spatial scale of many of these problems, they are usually addressed in a relatively straight-forward manner, at large spatial scales. Once a problem has been identified, it is a relatively simple procedure to identify available restoration approaches and more specific management measures and techniques for their implementation. To the user, the tree can thus be interpreted and used in a relatively simple "general problem, specific problem, solution" manner.

2. Rivers and Streams

Interpretation and use of the information tree developed for rivers and streams is more complicated because of the dynamic nature of flowing water systems and their integral links with broader watershed systems. The physical structures of rivers and streams constantly change as channels work and rework their banks and floodplains. Banks erode; river meanders become backwaters, oxbows, and marshes; pools and riffles move and shift. Only the overall, large-scale physical structure (channel sinuosity, riffle to pool ratios, stream gradients, etc.) are at a

Table 2. RESTORATION INFORMATION TREE FOR LAKES AND PONDS

Broad Problem Area/ Management Approach	Management Measure	Management Technique	Major Engineering Features
<p>EUTROPHICATION</p> <p>Reduce inputs of nutrients/organics</p>	<p>Intercept or divert nonpoint sources</p>	<p>Construct stormwater detention basins or retention ponds</p>	<p>Requires earthmoving equipment, placement of outlet structures (e.g. concrete culverts with piping), possibly inlet structures (e.g. concrete or stone rip-rap), possibly flow dividers</p>
		<p>Construct sedimentation basins on inflow streams</p>	<p>Requires earthmoving equipment, outlet and inlet structures</p>
		<p>Divert runoff or inflow streams through constructed wetlands</p>	<p>Requires creation of wetland hydrology and planting of appropriate species (emergent plants such as cattails in temperate wetlands)</p>
<p>Reduce in-situ nutrient/organic concentrations and cycling</p>	<p>Reduce contaminants in water column</p>	<p>Phosphorus precipitation: add phosphorus-precipitating chemicals directly to waters</p> <p>Dilution: dilute with nutrient-poor inflow waters</p>	<p>Application of low doses of aluminum sulfate or sodium aluminate (or calcium, iron salts)</p> <p>Requires a suitable nutrient-poor water source, and may require pumps and extensive engineering to divert water source, as well as outlet structure repair</p>
	<p>Reduce remobilization of contaminants from bottom sediments</p>	<p>Phosphorus Inactivation: add phosphorus-inactivating chemicals directly to waters</p>	<p>Application of high doses of aluminum sulfate or sodium aluminate</p>
		<p>Sediment Skimming: dredge the surface layer of bottom sediments</p>	<p>Requires hydraulic dredge equipped with a cutterhead (or grab-bucket) and a suitable containment area (e.g. diked bays or upland ponds) for the sediment water slurry. Return flows from containment areas may need to be treated.</p>
		<p>Sediment Oxidation: add chemicals to bottom sediments to accelerate the oxidation and denitrification of organic matter and bind phosphorus with iron in the top 5-10 cm of sediment</p>	<p>Requires injection of calcium nitrate into top layer of bottom sediment. If sediments are low in iron, requires prior application of ferric chloride. Prior application of calcium hydroxide (lime) may also be needed to bring pH to optimum levels for denitrification</p>
		<p>Hypolimnetic withdrawal: siphon the nutrient-rich deep stagnant water layer and discharge to receiving streams</p>	<p>Requires water pump and piping, and an aeration device to treat siphoned water before it is discharged to receiving streams</p>
<p>Increase dissolved oxygen</p>	<p>Hypolimnetic Aeration: add oxygen directly to deep stagnant water level (the hypolimnion) while maintaining thermal stratification (requires deep hypolimnion to be effective)</p>	<p>Install air-lift aerators to bring cold hypolimnetic water to the surface, aerate it through contact with the atmosphere, and return it to the hypolimnion.</p>	<p>Requires one or more aerators placed in the hypolimnion, with attached piping reaching to the surface</p>
	<p>Direct injection of liquid oxygen into hypolimnion</p>		<p>Requires one or more tanks of oxygen placed on-site and connected to an air compressor and an air distribution system that includes supply heads submerged and anchored in the lake</p>

Table 2. RESTORATION INFORMATION TREE FOR LAKES AND PONDS

Broad Problem Area/ Management Approach	Management Measure	Management Technique	Major Engineering Features
	Artificial circulation: eliminate thermal stratification in summer by mixing of lake water column (not appropriate for lakes that support coldwater fish which use the hypolimnion as a thermal refuge during the summer)	Inject compressed air from a perforated pipe or ceramic diffuser tethered to the lake bottom	Air compressor, iron piping attachment, and perforated plastic piping attachment
	Winter Aeration: increase oxygen levels in the near surface lake waters during winter ice cover period to prevent winterkills	Remove snow cover from lake surface to increase light penetration and photosynthesis (may be sufficient to prevent winterkill in lakes with marginal levels of dissolved oxygen)	Manual snowblowers or snowplowing equipment
Reduce high primary productivity (i.e. manage the symptoms of eutrophication problems)	Control nuisance algae	Install one or more aerators in the lake Biomaniipulation: manipulate fish community to promote large zooplankton grazers	Stock lake with large piscivorous fish (e.g. walleyes) which feed on small planktivorous fish that prey on zooplankton grazers (may not be effective when algae is dominated by inedible species)
		Introduce algicides to kill nuisance algae	Copper sulfate is particularly good for controlling blue-green algae (use is restricted in some states). Simazine is also commonly used. Application is done by towing burlap or nylon bags filled with algicide granules behind a boat
		Artificial circulation	See earlier entries for circulation
	Control nuisance macrophytes	Remove macrophytes at the roots	Use a hydraulic dredge to remove macrophyte roots and deepen the lake to reduce photic zone
		Harvesting: cut and remove rooted plants and associated filamentous algae	Use a rototiller (barge-like machine with a hydraulically-operated device) to tear out plant roots (limited to depths of 12 ft.) Requires mechanical harvester: typically a low-draft barge designed with one horizontal and two vertical outlet bars, a conveyor to remove cut plants to a hold on the machine, and another conveyor to unload plants. Also requires a weed disposal option (e.g. to farmers for use as mulch and fertilizer)
		Herbicides: poison nuisance macrophytes using chemicals	Commonly used registered herbicides include Diquat, Endothal, 2,4-D, Glyphosate, and Fluridone. Requires applicator certification, insurance, and protective gear
		Biological controls: introduce plant-eating or plant pathogenic biocontrol organisms	Stock lake with Grass Carp (use is limited by law in some states) or other control species

Table 2. RESTORATION INFORMATION TREE FOR LAKES AND PONDS

Broad Problem Area/ Management Approach	Management Measure	Management Technique	Major Engineering Features
<u>HABITAT</u> Enhance fish spawning habitat	Improve existing spawning sites	Use water pressure to blow silt and algae off of, and to turn, rocky shoals (for walleye and other species)	Water pump mounted on a pontoon or raft
		Use small-scale dredging to remove plants and sediments from around underwater springs (for brook trout and other species)	Piping to identify springs; hydraulic dredge
	Construct new spawning sites	Construct rocky shoals by depositing gravel and rock (for walleye, brook trout, smallmouth bass and other species)	For walleye, 12-inch gravel and rock beds at depths of 1.5 to 4 feet. For brook trout, rock beds at depths of 15 feet. For smallmouth bass, boxes of gravel or graveling of large areas.
		Construct near-shore wood reefs and spawning slabs (for minnows)	Cut brush, spawning slabs, floating baskets
Create additional cover for fish	Construct artificial reefs	Artificial reef designs include: brush piles (largemouth bass, panfish), cribs (walleye, bass, panfish, catfish), stake beds (largemouth bass, crappie, panfish), piping (catfish and bullhead), concrete block and rock piles (catfish, bass, panfish, walleye)	Brush piles: brush placed in a frame of made of heavy wood or bundled together and weighted with concrete. Cribs: wooden frames made of heavy logs and filled with large rocks and brush. Stake beds: sawmill stakes and two-by-fours weighed by concrete construction blocks. Piping: smooth plastic piping or corrugated polyethylene pipes bundled together in pyramid shape with cement plug for ballast Concrete block and rockpiles: small piles of various size rock and broken concrete pieces
Increase dissolved oxygen levels	See other parts of table		
Manage nuisance macrophytes	See other parts of table		
<u>SEDIMENTATION/HYDROLOGY</u> Increase water depth	Remove bottom sediments	Dredge bottom sediments (see other parts of table)	
	Raise water level	Manipulate water control structures	
Reduce sediments loads	Intercept sediment inputs	See other parts of table	

Table 3. RESTORATION INFORMATION TREE FOR RIVERS AND STREAMS

Broad Problem Area/ Management Approach	Management Measure	Management Technique	Major Engineering Features
<u>HYDROLOGY/SEDIMENTATION</u>	Control stream energy, stabilize thalweg, alter sediment and stream bed dynamics: Approaches that emphasize local effects	Lower stream gradient to bring system nearer to dynamic equilibrium	Requires heavy machinery for excavating new stream bed; channel block to divert flow into new meander channel; frequently requires bank and flow stabilization structures
	Create local flow vortexes, small pools and eddies, and habitat complexity	In-stream placement of boulders and rootwads to create obstacles	Placed by hand or with heavy machinery, depending on size. Rootwads (uprooted tree stumps) require anchoring to stream bed
	Narrow stream channel to increase local flow velocity and scour	Channel constrictors	Any of a variety of structural materials, including logs and boulders
	Temporarily or permanently close off flows into side channels in braided or meandering streams	Channel blocks or closing dams	Any of a variety of structural materials, including logs and boulders
	Deflect flow away from bank increasing sinuosity of thalweg flow thus dissipating energy	Deflectors	Any of a variety of structural materials; primarily logs and boulders in small streams
	Check flow to dissipate energy, create riffle-pool patterns, and trap gravel	Weirs and check dams	Many different designs (e.g. wedge and K dams, double log weirs). Often built from in-situ materials in small streams, including logs and boulders.
Control stream energy, stabilize thalweg, alter sediment and stream bed dynamics: Approaches that emphasize watershed-scale effects	Desynchronize flows from upstream areas of the watershed using natural or constructed buffers	Stormwater retention, detention, and infiltration structures	Requires earthmoving equipment, outlet structures, possibly inlet structures and flow dividers
	Constructed wetlands	Constructed wetlands	Requires earthmoving equipment to construct of wetland hydrology; may require planting (See: non-tidal wetlands tree)
	Restore riparian areas or floodplains		May involve no more than the cessation of mowing along banks to complex recontouring floodplain with heavy excavation equipment
Stabilize shoreline	Approaches that rely on in-situ materials, stream dynamics and ecological processes to stabilize poorly vegetated banks and enable vegetation to become more firmly established	Brush mattresses and mats	Locally collected brush secured in broad pads stapled or staked into banks
	Brush bundles	Brush bundles	Locally collected brush wrapped in cylindrical bundles and secured across banks
	Live stakes, pre-rooted stakes	Live stakes, pre-rooted stakes	Stakes cut from hydrophytic shrubs planted along stream bank singly or in bunches.

Table 3. RESTORATION INFORMATION TREE FOR RIVERS AND STREAMS

Broad Problem Area/ Management Approach	Management Measure	Management Technique	Major Engineering Features
		Planting riparian vegetation	Trees, shrubs and herbs planted under dry, wet or intermediate conditions
		Fiber schines to provide rooting medium for shallow water plants	Floating mats, logs rolls or bundles of organic fibers
		Stream bank fencing to promote the re-establishment of vegetation	Barbed wire, chain link fencing
	Approaches that resist stream dynamics: engineered structures to absorb and deflect erosive flows and trap sediments adjacent to existing shore	Revetments	Sloping structures built from stone and other materials
		Bulkheads	Wall constructed along existing shore from stone, cement or other materials
		Gabion baskets	Wire baskets, filled on-site with cobbles used to construct a variety of revetments, inlet and outlet structures
		Wing walls, jetties, and breakwaters	Structures made of various materials placed perpendicular to shore or slightly off-shore
	Hybrid approaches for protecting against shoreline erosion	Boulders placed along banks	Placed by hand or heavy machinery, depending on size
		Rootwads keyed into stream banks	Uprooted trees keyed into stream bank, with roots exposed toward stream
		Gabions with willow or other shrubs	Gabions planted with shrubs or other vegetation
		Log revetment/log cover, half log cover	Structures made of logs or other locally available materials
<u>HABITAT</u> Increase habitat structure and diversity	Increase cover for fish	Bank overhangs (Bank crib with cover log, floating log cover, etc.)	Structures that create an artificial analog to overhanging banks by building a low overhang along the bank, anchoring it, and overlaying it with rocks, soils and vegetation. For example, bank cribs are constructed by anchoring submerged abutment logs perpendicular to the sides of stream banks, covered with layers of other logs placed alternatingly parallel and perpendicular to bank, and topped with rocks and brush.
		Brush bundles, tree cover, tree layering	Trees and shrubs placed in-stream along banks. May be as simple as felling a tree in the stream, or as complex as layering many shrubs and trees along the shoreline and anchoring with staples, rebar, or boulders

Table 3. RESTORATION INFORMATION TREE FOR RIVERS AND STREAMS

Broad Problem Area/ Management Approach	Management Measure	Management Technique	Major Engineering Features
		Log/boulder complexes	Placed by hand or with heavy machinery, depending on size
		Rootwads	See other parts of table
	Increase and enhance fish spawning areas	Gravel placement	Placement by heavy machinery or by hand, depending on amount
		Gravel traps	See entries for deflectors/check dams (many structures that modify local hydrology will either trap gravel or increase local flows and scour fine materials from the interstices of embedded gravel)
	Reduce water temperature	Plant riparian vegetation; stream bank fencing to promote re-establishment of vegetation	See other parts of table
		Bank overhangs	See other parts of table
		Brush bundles; Tree layering	See other parts of table
Reduce barriers to fish migration and movement		Fish screens	Placed at water outlets (e.g. to irrigation systems)
		Fish ladders	Requires complex engineered structures to allow fish to move past existing dams
		Fish passages for low flow conditions	Construct or replace culverts below stream grade
EUTROPHICATION			
Reduce inputs of nutrients/organics	Intercept nonpoint sources	Construct stormwater retention, detention and infiltration structures	See other parts of table
		Constructed wetland	See other parts of table
		Restore riparian areas or floodplains	See other parts of table
		Agricultural and urban BMPs	Various practices
		Reduce impervious surfaces	Various practices

Table 4. RESTORATION INFORMATION TREE FOR NON-TIDAL WETLANDS

Broad Problem Area/ Management Approach	Management Measure	Management Technique	Major Engineering Features
<p><u>HYDROLOGY</u></p> <p>Establish appropriate topography</p>	<p>Move soil/substrate in the dry</p>	<p>Excavation/grading</p>	<p>Requires very careful grading (\pm 4 inches or so at worst). Topography of the best wetland projects often involves complex contouring, construction of creeks and drainage networks, etc. Excavation usually with appropriate heavy equipment, including bulldozers, backhoes, loaders, dumptrucks, and so forth.</p>
		<p>Blasting/explosives</p>	<p>If you need explosives, the site is not an especially auspicious one for wetland creation or restoration.</p>
	<p>Move soil/substrate in the wet</p>	<p>Dewater site</p>	<p>Pumps, temporary coffer dams, diversion of surface water flow</p>
		<p>Excavate/grade moderate/wet site</p>	<p>Requires very careful grading (\pm 4 inches or so at worst). Wetland soils may be mechanically unstable, temporary access roads or pads may be needed, or heavy machinery specially designed for use on wet soils may be necessary.</p>
		<p>Excavate/grade submerged site</p>	<p>Requires very careful grading (\pm 4 inches or so at worst). Sites suitable for wetland restoration may be too shallow for use of barges. Excavation from temporary pads or from shoreline using draglines, backhoes, etc may be necessary.</p>
	<p>Dispose of soil/substrate</p>	<p>Use on-site or on related project</p>	<p>Use of excess fill on-site or on related projects can save money. Disposal or fill especially expensive near urban areas.</p>
		<p>Dispose off-site</p>	<p>On projects requiring substantial excavation, may be single largest expense for entire project.</p>
<p>Establish Appropriate Hydrology</p>	<p>Wetland linked to perennial surface waters</p>	<p>Establish appropriate topography</p>	<p>See above. Careful calculation of surface and ground water elevations in wetland should be carried out to ensure appropriate responses to storm events and drought.</p>
		<p>Eliminate artificial drainage</p>	<p>Break drain tile, fill or plug drainage ditches. Precise characteristics of resulting wetland may be difficult to predict without expensive hydrologic study.</p>
		<p>Construct dikes to contain/retain water</p>	<p>May sever many of the dynamic links between wetland and adjacent surface water systems. Construction of dikes and water control structures usually relatively straightforward. Often carried out in multiple cells with independent or quasi-independent water control systems. Most useful for narrowly-focused wetland management efforts (e.g. Waterfowl production).</p>

Table 4. RESTORATION INFORMATION TREE FOR NON-TIDAL WETLANDS

Broad Problem Area/ Management Approach	Management Measure	Management Technique	Major Engineering Features
		Build dam	Small, low dams on perennial streams can flood additional area. Construction poses no special problems. Applicability highly dependent on local topography. May have serious consequences for fish and wildlife migrations along stream corridor, may increase stream temperatures.
		Divert water flow	Diversions can produce appropriate wetland conditions, but may have impacts on donor stream. Maintenance costs can be high if not designed with both peak and drought flow conditions in mind.
		Active water pumping	O&M costs can be relatively high. Places maintenance of wetland conditions entirely into the hands of managers. Wetland benefits therefore dependent on long-term O&M commitments.
	Wetland linked to non-permanent surface runoff	Establish appropriate topography	See above. Careful calculation of surface and ground water elevations in wetland should be carried out to ensure appropriate responses to storm events and drought.
		Construct dikes or basin to contain/retain water	Construction of dikes, basins and water control structures relatively straightforward. Very useful for capturing ephemeral stream flows to produce permanent wetland conditions. Commonly used in urban areas, and where rainfall is episodic or strongly seasonal.
	Wetland linked to ground water	General comment	Post-project hydrology very difficult to determine for sites relying on groundwater. Probably should only consider restoring groundwater dominated wetlands when the hydrology of the region is little disturbed, and local drainage systems are easily destroyed. Where substantial excavation will be required, extensive groundwater monitoring and modeling will be essential, and even then, success is not assured.
		Establish appropriate topography	See above. Careful calculation of surface and ground water elevations in wetland should be carried out to ensure appropriate responses to storm events and drought.
		Eliminate Artificial Drainage	Break drain tile, fill or plug drainage ditches. Cheap and relatively effective. Success depends on the degree of alteration of regional hydrology.

Table 4. RESTORATION INFORMATION TREE FOR NON-TIDAL WETLANDS

Broad Problem Area/ Management Approach	Management Measure	Management Technique	Major Engineering Features
<u>HABITAT</u> Correct soil problems	Soil amendments	Fertilize soil	Often used to help newly planted plants get a fast and healthy start. Slow release fertilizer essential.
		Change soil texture	Coarse soils (gravelly or sandy) are often unsuitable for wetland establishment. Additions of fines or organic matter (compost) may be necessary for successful establishment of wetland vegetation.
	Remove problem soils	saline soils	Remove saline soils and replace with non-saline soils or fill.
		Soil toxicity/pollution	Site should be avoided if possible. Control inputs of pollutants if possible. Badly polluted soils can be removed, and replaced with fill if necessary. Stormwater management devices can help prevent continued inputs. Bacterial reduction of organic matter in wetland can detoxify some organic toxins.
Establish desired vegetation	Establish appropriate hydrology	See above	Often, if the hydrology is properly established, no more needs to be done to establish desirable wetland vegetation. This approach leads to long-term succession of the vegetation. Species with easily dispersed seeds and rapid growth become established first, with other species arriving sometimes many years later.
	Seeding	Broadcast seeding	Relatively inexpensive, often successful approach for establishing vegetation in wet meadows and similar seasonally-flooded sites. Failure somewhat more likely than with planting, but can re-seed several times for cost of planting equivalent area.
	Planting	Emergents	Plants differ widely in hydrologic requirements. Planting practice also differs by species. Some species can be successfully established from cut plugs, some planted as sprigs, some as potted, greenhouse-grown plants.
		Shrubs and trees	Plants differ widely in hydrologic requirements. Many hydrophytic species can be established from cut stakes. Plants available at various sizes from commercial producers. Price typically varies directly with size.

Table 4. RESTORATION INFORMATION TREE FOR NON-TIDAL WETLANDS

Broad Problem Area/ Management Approach	Management Measure	Management Technique	Major Engineering Features
	Use of Topsoil		Use of topsoil reserved from a disturbed wetland can speed establishment of a diverse wetland plants community. Plants become established from seeds, rhizomes, and root fragments. Method tends to favor species with resistant rhizomes or small, persistent seeds. Species composition may vary somewhat depending on when original soils were collected. If soils are improperly stored, decay of organic matter may build up sufficient heat to sterilize the soil.
Eliminate undesirable vegetation	Control water level fluctuations	Water control structures	Most useful in wetlands in which water control structures allow relatively precise control of water depths. Following cutting or mowing of wetland, flooding from mid fall over the winter often drowns invasive plants. Technique does not eliminate soil seed bank and often reduces litter layer, thus encouraging widespread re-invasion.
	Establish appropriate hydrology	See above	Invasive species are often favored by highly variable water levels, or by certain hydrologic conditions.
	Physical removal	Uprooting by hand	Can be a very effective for preventing establishment of invasive species in restored wetland while preferred vegetation becomes well established.
		Cutting by hand	Allows access to parts of wetland inaccessible to machinery. Allows selective cutting.
		Mechanical mowing	Requires that wetland be dry enough for access by machinery. Not selective. Effects on plant community variable, depending on species composition and nutrient dynamics. Favors emergents, grasses and forbs over trees and shrubs, at least in the short term.
		Disking	Typically thins, but does not eliminate, existing vegetation. Disturbs surface litter layer, encouraging germination of seeds in soil seed bank. May make infestation of species with abundant, small seeds worse.
		Bulldozing	Rapid, non-selective, destroys surface litter layer. Typically followed by establishment of desirable vegetation.
	Herbicides	Broadcast	Few herbicides certified for use in wetlands or over water. Glyphosate is most commonly used. May require multiple applications. Often very effective.

Table 4. RESTORATION INFORMATION TREE FOR NON-TIDAL WETLANDS

Broad Problem Area/ Management Approach	Management Measure	Management Technique	Major Engineering Features
		Applied to cut stems or stumps	Widely used for control of re-sprouting of woody species, and for control of mowed infestations of large emergents with substantial below-ground storage.
	Burning		Timing of burn very important for determining success of burn and species composition of recovering wetland. Often used to increase primary productivity in managed wetlands, but may provide ideal conditions for invasion by undesirable exotic species.
	Grazing	Common domestic animals	Most useful in wet meadows and prairies. Typically changes species composition of the wetland. Palatable groups, like <i>sparina</i> sp. and <i>carex</i> sp. are reduced, while relatively unpalatable ones like <i>juncus</i> sp. are favored. Precise effects depend on wetland type and species of grazer selected.
	Combinations		Weed control often uses a combination of strategies. Cutting + herbicides, cutting + flooding, burning + herbicides are perhaps most common.
<u>EUTROPHICATION</u> Reduce inputs of nutrients/organics	Intercept pollutants	Stormwater retention, detention, and infiltration structures	Properly designed and maintained, will reduce sediment and phosphorus inflow.
		Constructed wetlands	Can trap sediments and phosphorus. May also remove available nitrogen via denitrification.
		Agricultural BMP's	Reduces soil and nutrient losses from agricultural lands.
		Urban BMP's	Reduces flow of nutrients and sediments to urban wetlands.

Table 5. RESTORATION INFORMATION TREE FOR TIDAL WETLANDS

Broad Problem Area/ Management Approach	Management Measure	Management Technique	Major Engineering Features
<p><u>HYDROLOGY</u></p> <p>Establish appropriate topography</p>	<p>Move soil/substrate in the wet</p>	<p>Excavate/grade</p>	<p>Requires very careful grading (\pm 4 inches or so at worst). Site typically submerged or partially so at high tide, more or less wet and unstable at low tide. Work can typically be done at low tide.</p>
		<p>Trap long-shore sediments</p>	<p>Carefully constructed low breakwaters can trap sediments and establish appropriate elevations for growth of salt marsh vegetation.</p>
		<p>Establish tidal creeks</p>	<p>Can be done by excavation, but often done by placing straw bales slightly below grade before placing topsoil. When straw bales decay, a tidal creek or "gut" is formed.</p>
	<p>Dispose of soil/substrate</p>	<p>Use on-site or on related project</p>	<p>Use of excess fill on-site or on related projects can save money. Disposal of fill especially expensive near urban areas.</p>
<p>Establish appropriate hydrology</p>	<p>Tidal waters</p>	<p>Dispose off-site</p>	<p>On projects requiring substantial excavation, may be single largest expense for entire project.</p>
		<p>Establish appropriate topography</p>	<p>See above. Understanding of tidal dynamics and water flow across the wetland and through tidal creeks is important to prevent development of stagnant backwaters and salt pans.</p>
		<p>Eliminate artificial blockages to tidal inundation</p>	<p>Cut through dikes, build culverts under roads and highways, etc. Cheap and effective. Often re-establishes tidal and saline influences to an area long isolated from the tides. Appropriate planting for new conditions is advisable.</p>
		<p>Eliminate artificial drainage</p>	<p>Break drain tile, fill or plug drainage ditches. Typically alters wetland character, rather than establishing wetland where it was not previously found.</p>
	<p>Control wave energy and erosion</p>	<p>Site selection</p>	<p>Establishment of tidal wetlands is likely to fail where wave energies from boat wakes, offshore swells, or wind-induced waves are great. Young plants have poorly developed root systems, and get washed away easily.</p>
		<p>Offshore breakwaters</p>	<p>Blocks erosive waves. Many designs possible. Can be used to trap sediments to allow gradual expansion of wetland area.</p>
		<p>Low-profile revetment</p>	<p>Minimizes undercutting of marsh, protects young plants from summer storms.</p>

Table 5. RESTORATION INFORMATION TREE FOR TIDAL WETLANDS

Broad Problem Area/ Management Approach	Management Measure	Management Technique	Major Engineering Features
<u>HABITAT</u> Correct soil problems	Soil amendments	Temporary or floating breakwaters Fertilize soils Change soil texture	Protect plants until established. Fertilize wetland. Often used to help newly planted plants get a fast and healthy start. Slow release fertilizer essential. Coarse soils (gravelly or sandy) are often unsuitable for wetland establishment. Additions of fines or organic matter (compost) may be necessary for establishment of wetland vegetation.
		Increase soil acidity Acidic soils	Add lime or crushed limestone. Acidity results from the oxidation of sulfates in marine-influenced soils. Best defense is to avoid exposing soils to oxidation. Otherwise, soils must be removed.
	Remove problem soils	Soil toxicity/pollution	Site should be avoided if possible. Control inputs of pollutants if possible. Badly polluted soils can be removed, and replaced with fill if necessary. Stormwater management devices can help prevent continued inputs. Bacterial reduction of organic matter in wetland can detoxify some organic toxins.
Establish desired vegetation	Establish appropriate hydrology	See above	Often, if the hydrology is properly established, no more needs to be done to establish vegetation.
	Seeding	Broadcast seeding	Seeding is seldom used in salt marshes, because of the difficulty of preventing erosion and removal of seeds. Seeding may be used in portions of mangrove establishment projects where protection from waves is sufficient.
	Planting	Emergents	Salt marsh planting typically carried out in two or three bands, emphasizing species and ecotypes with different flooding tolerances. Planting practice differs by species, but plugs and sprigs are common.
		Shrubs and trees	Mangrove planting usually done with seedlings, often greenhouse-grown. Size is an important factor in planting success.
	Use of topsoil		Use of topsoil reserved from a disturbed wetland is uncommon in tidal restorations.
Eliminate undesirable vegetation	Establish appropriate hydrology	See above	Invasive species are often favored by unusual hydrologic conditions.

Table 5. RESTORATION INFORMATION TREE FOR TIDAL WETLANDS

Broad Problem Area/ Management Approach	Management Measure	Management Technique	Major Engineering Features
	Physical removal	Uprooting by hand	Can be a very effective control at preventing establishment of invasive species in restored wetland while preferred vegetation becomes well established.
		Cutting by hand	Allows access to parts of wetland inaccessible to machinery. Allows selective cutting.
		Mechanical mowing	Not selective. Effects on plant community variable, depending on species composition. Seldom eliminates <i>Phragmites</i> , unless combined with other methods.
	Herbicides	Broadcast	Few herbicides certified for use in wetlands or over water. Glyphosate is most commonly used. May require multiple applications. Often very effective.
		Applied to cut stems or stumps	Widely used for control of <i>Phragmites</i> . May be used for control of re-sprouting of woody species in freshwater tidal wetlands.
	Burning	Controlled fire maintenance	Often used to increase primary productivity in managed wetlands, but may encourage invasion by undesirable exotic species.
	Grazing	Common domestic animals	Most useful in wet meadows and prairies. Typically changes species composition. Palatable groups, like <i>Spartina</i> sp. and <i>Carex</i> sp. are reduced, while relatively unpalatable ones like <i>Juncus</i> sp. are favored. Precise effects depend on wetland type and species of grazer selected.
	Combinations		Weed control often uses a combination of strategies. Cutting + herbicides, cutting + flooding, burning + herbicides are perhaps most common.
EUTROPHICATION Reduce inputs of nutrients/organics	Intercept pollutants	Stormwater retention, detention, and infiltration structures	Properly designed and maintained, will reduce sediment and phosphorus inflow.
		Constructed wetlands	Can trap sediments and phosphorus, but may also remove available nitrogen via denitrification.
		Agricultural BMP's	Reduces soil and nutrient losses from agricultural lands.

Table 5. RESTORATION INFORMATION TREE FOR TIDAL WETLANDS

Broad Problem Area/ Management Approach	Management Measure	Management Technique	Major Engineering Features
		Urban BMP's	Reduces flow of nutrients and sediments to urban streams.
		Riparian buffers/floodplain condition (vegetation And hydrology)	Well established riparian vegetation and natural floodplain morphology can provide sediment trapping, nutrient removal.
		Reduction in impervious surfaces or increase in forest area	Reduces general sources of nutrients in the landscape.

Table 6. TECHNIQUES FOR RESTORING LAKES AND PONDS: SUMMARY INFORMATION MODULES

Management Technique	When Appropriate/Effectiveness	Means/Costs	Ancillary Ecological Effects
Construct stormwater detention basins/retention ponds	Effective for controlling nutrient inputs, as well as silt and toxic metals. See Walker (1987) for performance standards.	Means and design criteria are discussed in Walker (1987).	
Construct sedimentation basins on inflow streams	Effective for controlling sediments and associated nutrients, and other contaminants. For case example see Fiala and Vasata (1992).	Means and design criteria are discussed by Benndorf and Putz (1987). Sedimentation basins become filled in over time, requiring periodic dredging.	
Divert point sources or inflow streams through man-made or engineered natural wetlands	Can sometimes be effective in retaining suspended solids and associated nutrients, as well as other contaminants. See Barten (1987) for case example.	Means are discussed by Reddy and DeBush (1987). See Wetlands table for more information.	
Dilution--dilute lake waters with nutrient-poor inflow waters	Few case histories exist because of the difficulty of finding new water sources low in nutrients. The best documented case is Moses Lake, WA where problems with transparency and algal were improved dramatically (see: Cooke et al. 1986) Best suited to lakes with high flushing rates and moderate phosphorous problems (Olem and Flock, 1992).	The primary need is an additional water source low in nutrients. Initial and O&M costs could be very large, depending on the need for pumps, extensive engineering, outlet structure repair/construction, and proximity of new water source (Olem and Flock, 1992).	Increased volume of water released could produce negative effects downstream, or to the water body form which water was diverted.
Add phosphorous-precipitating chemicals to lake waters	Low dose application of aluminum salts can effectively reduce phosphorous levels in the water column, but effects will be short-lived if high nutrient inputs or internal release of nutrients from lake sediments are not controlled.	Olem and Flock (1990) report that capital and O&M costs are low in relation to other in-lake management methods.	Olem and Flock (1990) report that the potential for negative impacts is low in relation to other in-lake management techniques.
Add phosphorous-inactivating chemicals to lake waters	High dose application of aluminum salts to lakes has been highly effective and long-lasting method for reducing re-mobilization of nutrients in bottom sediments in thermally stratified, natural lakes (when nutrient inputs have been controlled). Shallow, unstratified lakes and ponds have shorter periods of treatment effectiveness. See Olem and Flock (1990).	Initial costs are dominated by labor and chemical costs which are a function of dosage. Peterson (1982a) reports means and cost estimates which are compared favorably with the costs for sediment removal (see below).	Introducing high doses of alum can produce toxic effects on lake species.

Table 6. TECHNIQUES FOR RESTORING LAKES AND PONDS: SUMMARY INFORMATION MODULES

Management Technique	When Appropriate/Effectiveness	Means/Costs	Ancillary Ecological Effects
Sediment skimming--dredge surface layer of bottom sediments	If nutrients are concentrated in the upper layers of sediments, dredging can be highly effective for reducing internal loadings, but long-lasting results require controlling nutrient incomes. See Dunst, et al. (1984) for a case study in Wisconsin.	Means and technical considerations are discussed in Barnard (1978) and Peterson (1982b). Dredging costs are highly variable depending on site conditions and factors, but typically involve substantial initial capital costs. Peterson reports a cost range of \$0.40 to \$23.35 per cubic yard (in 1988\$) for 64 cases studied, but costs in the smaller range of \$2-3 per cubic yard were typical. See MCASE for unit cost data.	Can negatively effect benthic communities and may disturb fish spawning areas. The containment area for water slurry must be sized adequately to ensure settling; otherwise nutrient-rich waters will be returned to the lake.
Sediment Oxidation--inject calcium nitrate into bottom sediments	While considered experimental, Olem and Flock rate its short- and long-term effectiveness as good in relation to other in-lake management techniques. See Rippl and Lindmark (1978) for a case example in Sweden and Willenbring (1984) for an example in Minnesota.	Means and technical considerations are discussed in Rippl (1976) and Wedepohl, et al. (1990). Olem and Flock (1990) report that capital costs are average in relation to other in-lake management techniques, and O&M costs are relatively low.	Olem and Flock report that the potential for negative effects is low in relation to other in-lake management techniques.
Hypolimnetic Withdrawal--siphon nutrient-rich deep water layer and discharge to receiving streams	Although not widely used, has produced good results in deep, thermally stratified lakes (National Research Council, 1992). Olem and Flock (1990) report its short- and long-term effectiveness as good in relation to other in-lake management techniques. See Nurnberg (1987) for a review of 17 case studies.	Means and technical considerations are discussed in Nurnberg (1987) and Wedepohl et al. (1990). Olem and Flock report that capital costs for pump, piping and an aeration device for treating siphoned water before discharge are low in relation to other in-lake management techniques, and O&M costs (for labor and fuel) are very low. Discharge to receiving streams may require federal or state permits.	High discharge rates could result in midsummer partial mixing of the water column (early destratification) leading to algal blooms (National Research Council, 1992). Also possible downstream effects.
Hypolimnetic Aeration--install air-lift aerators in the hypolimnion	Effective for maintaining cold-water fisheries when properly sized and installed, provided they are operated continuously during stratified periods (i.e. summer months). Suited to deep, stratified lakes; generally ineffective in shallow lakes and ponds (National Research Council, 1992). See Taggart and McQueen (1981) and Smith et al. (1975) for case examples.	Means and technical considerations are discussed in McQueen and Lean (1986). Pastorek, et al. (1982) and Kortmann (1989) discuss site-specific factors determining the number and size of aerators required for some site. Olem and Flock (1990) report that capital and O&M costs are relatively large in relation to other in-lake management techniques. Cows are determined by the amount of compressed air needed, which is a function of several site-specific factors (See: Kortmann, 1989)	
Aerate the hypolimnetic by injecting liquid oxygen	As with aerators, this option for increasing dissolved oxygen levels in deep stratified lakes is effective if treatment continues throughout stratified period. See Prepas et al. (1990) and Mauldin et al. (1988) for case examples.	Means and technical considerations are discussed by Prepas et al. (1990). Baker et al. (1993) report that recent studies suggest this technique may often be more cost-effective and practical than the use of air-lift aerators (see: Aquatic Systems Engineering, 1990).	

Table 6. TECHNIQUES FOR RESTORING LAKES AND PONDS: SUMMARY INFORMATION MODULES

Management Technique	When Appropriate/Effectiveness	Means/Costs	Ancillary Ecological Effects
Artificial Circulation--inject compressed air into hypolimnion	Effective for preventing and reducing low dissolved oxygen problems, but provides little long-lasting benefits when circulators are shut off (National Research Council, 1992). Not appropriate for some lakes since mixing will eliminate the deep cold-water layer and thus the possibility of cold-water fisheries (Olem and Flock, 1990).	Means and technical considerations are discussed by Cooke et al. (1986) and Wedepohl, et al (1990). Olem and Flock (1990) report that costs are fairly low in relation to other in-lake management techniques. They include primarily capital costs for an air compressor and installation of pipes and a diffuser.	Dramatic change inlake nutrient dynamics to be expected (National Research Council, 1992).
Winter Aeration--install aerators	Appropriate and effective for preventing winter fishkills in shallow productive lakes in northern climates (see: Wirth, 1988).	Means, costs and technical considerations are discussed in McComas (1993) and Cooke et al. (1986). O&M costs for fuel to run aerators is the major cost component.	Can cause ice surface to weaken and open, creating danger for recreators.
Winter Aeration--remove snow from lake ice cover	May be sufficient to prevent winter fishkills in lakes with marginal dissolved oxygen problems. Most effective in shallow lakes with abundant rooted macrophytes (McComas, 1993).	Technique is low-tech and low-cost-- inputs include labor, snowblowers and fuel. See McComas (1993) for a discussion of methods and means.	
Biomanipulation for control of nuisance algae--stock lake with large piscivorous fish	Best suited for lakes dominated by planktivorous fish prior to treatment; addition of predators must achieve tenfold or greater changes in planktivore biomass to be effective (Carpenter and Kitchell, 1988; Gulati et al., 1990). For case example, see Kitchell (1991).	Means and technical considerations are discussed in Gulati et al. (1990). Costs are highly lake-specific, but generally are very low in relation to other in-lake management techniques (Olem and Flock, 1990).	
Add algicides to kill nuisance algae	Copper sulfate is effective in the short term, particularly against blue-green algae. Typically requires repeated applications (see: Cooke and Carlson, 1989).	Means, costs, and dosage are discussed by Cooke and Carlson (1989). Although material costs are low in relation to those for other in-lake management techniques, the necessity for repeated applications pushes O&M costs up, reducing the cost-effectiveness of this technique (Olem and Flock, 1990).	Can cause significant negative effects, including fish toxicity, copper accumulation in sediments, dissolved oxygen depletions, copper toxicity to invertebrates, among others (see: Hanson and Stephan, 1984).
Artificial Circulation for the control of nuisance algae	Has had mixed results for controlling algae; success depends on whether circulation reduces the pH of surface water (see: Shapiro, 1990)		
Sediment removal to remove macrophyte roots and deepen the lake to decrease light availability	Effective for eliminating rooted macrophytes and also provides a long-term solution for some macrophyte types by reducing the photic zone (provided sediment incomes are controlled).	See entries for Sediment Skimming.	See entries for Sediment Skimming.

Table 6. TECHNIQUES FOR RESTORING LAKES AND PONDS: SUMMARY INFORMATION MODULES

Management Technique	When Appropriate/Effectiveness	Means/Costs	Ancillary Ecological Effects
Sediment tilling using a rototiller to remove macrophyte roots	Newroth and Soar (1986) report that rototilling to remove watermilfoil may be as effective as 3-4 harvesting operations. Effects are not as long lasting as those provided by sediment removal	Means and costs are discussed by Newroth and Soar (1986); they report costs comparable to those for herbicides and harvesting options.	Can negatively affect benthic communities and may disturb fish spawning areas; may release nutrients, sediments, or organic matter into the water column, affecting ecosystem processes (Olem and Flock, 1990).
Mechanical harvesters for cutting and removing rooted macrophytes	Effective in the short term for reducing nuisance macrophytes and removing organic matter and nutrients. Most effective in northern waters; not good in southern waters where rates of regrowth are high. See Conyers and Cooke (1983) for case examples and comparison with other control techniques.	Olem and Flock (1990) report costs in the midwest have ranged from \$140-\$310 per acre, and often exceed \$1000 per acre in Florida. Estimates of needed inputs and costs can be obtained from the USACE "HARVEST" mechanical simulation model that is available from the Waterways Experiment Station (see: Hutto and Sabol, 1986).	Can cause some plant species (e.g. watermilfoil) to fragment and disperse, thus increasing abundance (see: Nicholson, 1981). Can also kill young fish in spawning and nursery areas.
Herbicides for controlling nuisance macrophytes	Effective short term solution; at recommended doses exhibits low toxicity to nontarget species. Represents the only way to clear certain choked waters (e.g. exotic water hyacinth in the Southeast). Shireman et al. (1982) discuss relevant site-specific factors for determining appropriateness.	Determination of appropriate chemical and dose is discussed by Westerdahl and Getsinger (1988). Olem and Flock (1990) report costs in the range of \$200-\$400 per acre; costs specific to lake location and plant type are discussed in Conyers and Cooke (1983) and Shireman (1982).	Plant decomposition releases nutrients in water column and consumes dissolved oxygen. May have negative effects on desirable plant species.
Biological control of nuisance macrophytes--stock with Grass Carp (exotic fish species)	Provides an effective long term solution without introducing expensive machinery or toxic chemicals. Not effective for controlling all aquatic plant types; prefer to feed on species such as elodea, pondweed and hydrilla. Feeding preferences are discussed in Cooke and Kennedy (1989). Use is common in FL, TX and AS, but banned in many states; see Allen and Wattendorf (1987) for state regulations.	Stocking rates for different plant species are discussed in Cooke and Kennedy (1989). Olem and Flock (1990) report the technique costs about \$90 per acre--much less than mechanical or chemical techniques. Costs are discussed in more detail by Cooke and Kennedy (1989) and Shireman (1982).	Eradication of macrophytes through overstocking can cause increases in nutrient concentration, algal blooms, and turbidity. Changes in fish communities likely and largely irreversible (Olem and Flock, 1990).
Water pressure to blow silt and algae off of and to turn rocky shoals	Effective for species such as walleye that do not mechanically clean lake bottoms before spawning (see: McComas, 1993).	Means are discussed by McComas (1993).	
Small-scale dredging to remove plants and sediments from around underwater springs	Effective for species such as brooke trout that spawn in upwelling groundwater in the littoral zone, tributary streams, or lake outlets (see: McComas, 1993). For a case example, see Carline (1980).	Means are discussed by McComas (1993).	

Table 6. TECHNIQUES FOR RESTORING LAKES AND PONDS: SUMMARY INFORMATION MODULES

Management Technique	When Appropriate/Effectiveness	Means/Costs	Ancillary Ecological Effects
Construct rocky shoals by depositing gravel and rock on lake bottom	Different designs are effective for different fish species (see: McComas 1993).	Means and case examples are discussed in McComas (1993).	
Construct near-shore wooded reefs and spawning slabs	Effective for minnow spawning and production (see: McComas, 1989)	For case example and means see (Everhart and Youngs, 1981).	
Construct artificial reefs	Different designs are effective for different fish species. Reefs should not be placed directly on existing productive habitat; several small reefs are at different water depths are preferable to one large unit (see: Baker, et al., 1993).	Means and costs are discussed by Phillips (1990).	

Prototype Information Tree for Environmental Restoration Plan Formulation and Cost Estimation

quasi-equilibrium state. Connections between flowing water systems and neighboring terrestrial systems are extremely close. The National Research Council (NRC) describes these interconnections and their implications for restoration projects in the following passage:

Rivers and their floodplains (or streams and their riparian zones) are so intimately linked that they should be understood, managed and restored as integral parts of a single ecosystem. In addition to this lateral linkage, there is an upstream-downstream continuum from headwaters to the sea or basin sink. The entire river-riparian ecosystem is contained within a drainage basin, so restoration must have a watershed perspective (NRC, 1992; p. 175).

Restoration projects in flowing waters are thus necessarily multi-faceted. The hydrology and sediment dynamics of the channel continually generate and regenerate habitats for fish and aquatic organisms. Thus even habitat quality is not really separable from broader stream dynamics. Without a healthy watershed-stream system, good habitat will not develop naturally, and if created by restoration actions, will not persist. Indeed, narrowly-defined stream restoration projects can be counterproductive.

The dynamism and interconnected nature of flowing water ecosystems makes it essentially impossible, in many cases, to identify one or more individual problems that need to be addressed by a restoration effort. In flowing water systems, the goal of restoration is almost always "to restore the river or stream to dynamic equilibrium" (NRC, 1992, p. 207). Indeed, the restoration approaches and techniques included in most stream restoration plans are typically based on a view of the stream as an integrated unit. These include "systems" and "carbon copy" approaches, and others based on stream classification systems (see: Rosgen, 1988).

Because stream restoration projects are fundamentally about managing whole ecosystems, project planners ordinarily will need to draw on a wide variety of approaches and techniques to effect complex changes in hydrology, sediment dynamics, and habitat. Thus, this ecosystem tree must be interpreted and used in a different manner than the tree for lakes and ponds. Instead of a "general problem, specific problem, solution" kind of interpretation, it must be viewed and used more as menu of approaches and techniques from which project planners will need to draw repeatedly to construct an overall restoration plan. The hierarchal organization of the tree is based on broad goals of stream restoration, but in practice the categories overlap so extensively that this listing must be viewed only as an organizational convenience.

3. Wetlands

The interpretation and appropriate use of the trees provided for non-tidal and tidal wetlands (Tables 4 and 5) is again somewhat different than the others due to the specific characteristics of these ecosystems. Wetlands are spatially heterogenous, and are often sensitive to disturbance from

*Prototype Information Tree for Environmental
Restoration Plan Formulation and Cost Estimation*

storms, herbivore outbreaks and other semi-periodic phenomena. Apparently minor changes in the timing, frequency, or depth of flooding can have profound effects on wetlands.

Most wetland restorations are basically efforts to establish desired plant communities (and their dependent animal communities) by creating appropriate physical structure and hydrology, spatial heterogeneity, and by eliminating undesirable vegetation. It is therefore difficult to conceive of a wetland restoration effort in terms of a "general problem, specific problem, solution" structure because the basic problem is almost one of how to get the desired physical environment and plant communities on site.

Thus, most wetland restorations face not a single broad problem but a series of interrelated problems. Restoration efforts must first establish appropriate topography and hydrology, followed by the establishment and maintenance of desired vegetation, often through planting, seeding, weeding, and other "gardening" or "farming" techniques. Therefore, the tree can be interpreted as providing a series of component tasks that will all be required for most wetland restorations projects--establish appropriate topography and hydrology; establish appropriate plant communities; and eliminate undesired exotic organisms. The tree reflects the sequential nature of wetland restoration efforts and can be interpreted and used in that manner.

Summary Information Modules

A preliminary effort was made to begin the process of implementing the summary information modules on management techniques for one ecosystem type--lakes and ponds (Table 6). Although it falls well short of full implementation, it illustrates the general types of data and information the modules could usefully provide, and points to additional sources of information that could be used to flesh out the database. When more fully implemented, the summary information modules would be expected to include more data and information at a much richer level of detail.

IV. FURTHER IMPLEMENTATION NEEDS

General Needs

The information trees developed and partially implemented in this report illustrate the form and content of a prototype information tool for restoration plan formulation and cost estimation. More research and data gathering will be needed to more fully develop and implement the tool, however. Toward that end, a list of sources of additional information is provided at the end of this report.

These and other information sources can be used to flesh out the contents of the main trees more fully in a number of ways. One would be to include directly within the trees more explanation of the listed management approaches and techniques. Another would involve providing much more detail on the major engineering features and components of management techniques. And more thorough research of the literature would likely turn up additional restoration approaches and techniques that could be used to branch the trees in new directions. It might also prove fruitful to explore in greater detail ways in which general site characteristics might be included more directly within the tree structure without greatly increasing its complexity and ease of use.

Most of the additional research needed to fully implement the information trees will involve the summary information modules, however. The biggest challenge involves implementing the information module on the means and costs of management techniques with data on the type and amount of inputs required and their unit costs. For some restoration techniques, data sources are available which can help fill this need. For example, the USACE's "MCACES" provides computerized cost profiles for hard engineering tasks conducted in aquatic environments (see: USACE, 1994). This data source should be mined for estimates of input requirements and unit costs for structural restoration techniques relating to, for example, stream bank stabilization (e.g. dikes and jetties), dredging, and water flow diversion.

For other types of restoration techniques, however, data on input requirements and unit costs often are not readily available. Much of the literature reviewed for this study reported on the costs actually incurred in implementing particular restoration projects, but these estimates typically are not documented well enough to be of practical use in the restoration tree context. For example, project-specific cost estimates often do not break down overall costs by the various techniques employed, document key site characteristics and the scale at which technique were applied, or distinguish between fixed and variable costs.

The generally poor quality of the historical data on restoration costs has motivated a number of efforts in recent years to develop cost estimates for hypothetical wetland and stream restoration projects from the ground up. For example, King and Bohlen (1993) estimated wetland restoration

Prototype Information Tree for Environmental Restoration Plan Formulation and Cost Estimation

costs by estimating input requirements associated with each essential task and applying unit cost data taken from standard construction cost guidebooks. Costs for various stream restoration techniques were calculated by King et al. (1994) and Apogee Research, Inc. (1994) in a similar fashion.

Each of the efforts cited above relied on information provided by restoration firms on the type and amount of inputs required to implement restoration techniques at various scales. This is a key data component for estimating the costs of restoration techniques, and one for which estimates typically cannot be found in the published literature.

Data sources on other components of means and costs are more readily available and could be tapped to implement this information module. For example, the types of component tasks involved in implementing restoration techniques often involve the same inputs and have the same cost basis as tasks routinely conducted in conventional construction projects. Thus, standard construction cost guidebooks that are used to budget commercial and residential construction projects can often provide a reasonable basis for assessing the costs of restoration techniques. And the information modules could also usefully cite to commercial firms that sell restoration equipment (e.g. mechanical aerators) and materials (e.g. wetland plant stock) as sources of information on input needs and costs.

Presentation Format

The prototype information tree for restoration planning is designed to assist project planners in the field. Once fully implemented it would be widely disseminated to project planners. There are at least four automated software alternatives or other options for making the information tree readily accessible to project planners. These are reviewed briefly below in light of the following features that would be expected to maximize the usefulness of the information tree for project planners. The presentation format should:

1. Permit the database to be readily expanded and updated as innovation and research change the available restoration options and information base.
2. Provide for interconnections between the data and information provided, thus allowing project planners to quickly and easily move from information on one potential restoration technique to that provided for other techniques.
3. Allow project planners to quickly and easily move forward and backward through the tree.

Option 1: Written Materials

This option would provide essentially the same presentation format as included in this report. It could be provided in loose-leaf form, for example, with detailed back-up data sheets providing the summary information modules for each restoration technique. This format would be relatively simple to produce and disseminate, and would satisfy the criteria described above. It might be especially useful for field-testing the tree concept.

Option 2: Standard Database Software

A full-featured relational database software package (e.g. D-Base for personal computers; related software packages for workstations) could be readily updated, and could handle the type of complex interconnections required to make an informational resource most useful. However, automating the information tree in this way would require extensive programming to make the product sufficiently easy to use. Database software is best suited to relatively rigid data structures that are explored in a relatively consistent way. It thus may be poorly suited to the type of uses envisioned for the restoration information tree.

Option 3: Expert Systems Software

Expert system software is intended to capture the accumulated expertise on some subject area in a series of interconnected questions that, when answered, lead to appropriate answers or recommendations. For example, these systems have been used to assist internists in the diagnosis of human disease. Expert systems are relatively inflexible in that they generally lead to one single answer rather than a series of options. They also tend to be difficult to modify and update.

Option 4: Hypertext and Hypermedia systems

Hypertext and hypermedia systems are flexible collections of documents, images, and other materials connected by informal links that point from one set of materials to another in essentially arbitrary ways (i.e. any way the user desires). Hypertext systems can thus relatively easily produce information structures of great flexibility and complexity. Hypertext systems can also be readily updated to reflect new information. With the recent development of the World Wide Web (WWW) on the Internet, and WWW readers on the Mosaic, hypertext structures can be readily decentralized to many separate tree users (and builders) scattered around the country. This might therefore be the best option for automating the tree concept once it is fully implemented and field tested.

GLOSSARY

Algae--Any of various chiefly aquatic, one-celled or multi-cellular plants without true stems, roots, and leaves but containing chlorophyll.

Algicide--A chemical agent used to destroy nuisance algae in bodies of water.

Anaerobic--Able to live and grow where there is no air or free oxygen.

Anoxic--Total deprivation of oxygen.

Anthropogenic--Relating to human actions.

Benthic organisms--Plants and animals that live on the beds of water bodies.

Bio-manipulation--Managing the level and mix of species within an aquatic ecosystem.

Biomass--The total mass of living matter within some defined environment.

Biota--Plant and animal life.

Braided Streams--Streams flowing in an interconnected network of channels.

Chlorophyll--The green pigment found in the chloroplast of plant cells.

Denitrification--To remove nitrogen from a material or chemical compound, as by bacterial action on soil.

Ecotones--Transitions between habitat types.

Ephemeral--Lasting a short time.

Epiphytic--A plant, such as a certain kind of orchid or fern, that grows on another plant on which it depends for mechanical support but not for nutrients.

Eutrophication--The over-enrichment of water bodies with nutrients and other organic matter.

Fiber Schines--Bundles of organic fiber placed along shorelines to reduce erosion and provide a stable rooting medium for plant establishment.

***Prototype Information Tree for Environmental
Restoration Plan Formulation and Cost Estimation***

Filamentous--Very slender, thread-like.

Geomorphic--Pertaining to the shape or surface configuration of the ground.

Herbivore--An animal that feeds on plants.

Hypolimnion--In a thermally stratified lake, the layer of water below the thermocline and extending to the bottom of the lake; water temperature in the Hypolimnion is virtually uniform.

Hypoxic--Deficiency in the amount of oxygen reaching tissues.

Macrophytes--A macroscopic plant in an aquatic environment.

Non-refractory organic material--Organic material that is readily available for bacterial decomposition.

Pathogenic (Pathogen)--Producing disease.

Photic zone--The layer of a water body in which light penetrates.

Phytoplankton--Microscopic floating aquatic plants.

Piscivorous fish--Fish that feed on fish.

Planktivorous fish--Fish that feed on zooplankton

Plankton--Microscopic plant and animal organisms that float or drift in great numbers in fresh or salt water.

Production--The process by which plants manufacture organic compounds from simple inorganic substances in the presence of sunlight.

Rhizomes--A rootlike, usually horizontal, stem growing under or along the ground that sends out roots from its lower surface and leaves or shoots from its upper surface.

Sessile--Having no stalk and attached directly at the base.

Zooplankton--Floating, often microscopic aquatic animals.

**REFERENCES AND SOURCES
OF ADDITIONAL INFORMATION**

General

National Research Council. 1992. Restoration of Aquatic Ecosystems. National Academy Press. Washington, DC.

U.S. Army Corps of Engineers. 1994. Cost Effectiveness Analysis for Environmental Planning: Nine Easy Steps. Institute for Water Resources, IWR Report 94-PS-2. (October)

----- 1994. Ecosystem Restoration Planning in the Civil Works Program. Draft EC 1105-2-210, (June).

----- 1993. Bussey Lake: Demonstration Study of Incremental Analyses in Environmental Planning. Institute for Water Resources. IWR Report 93-R-16. (December).

Restoration Cost Data

Apogee Research, Inc. 1994. Economic Development and Employment Effects of Non-Structural Stream Restoration. Report prepared for the U.S. Environmental Protection Agency and the U.S. Army Corps of Engineers. Bethesda, MD.

King, D. and C. Bohlen. 1994. Making Sense of Wetland Restoration Costs. University of Maryland Center for Environmental and Estuarine Studies, Solomons, MD. (January).

King, D., C. Bohlen and M. Kraus. 1994. Stream Restoration: The Costs of Engineered and Bio-Engineered Alternatives. University of Maryland Center for Environmental and Estuarine Studies, Solomons, MD. (April).

University of Maryland. 1994. The Cost of Wetland Creation and Restoration. Report prepared for the U.S. Department of Energy by the U.M. Center for Environmental and Estuarine Studies, Solomons, MD. (July).

U.S. Army Corps of Engineers. 1994. MCACES. Civil Works Construction Cost Estimating.

***Prototype Information Tree for Environmental
Restoration Plan Formulation and Cost Estimation***

Construction Cost Guidebooks

Dodge Guide to Public Works and Heavy Construction Costs. Published annually. (McGraw-Hill).

Kerr's Cost Data for Landscape Construction. Published annually. (Van Nostrand Reinhold).

Means Site Work Cost Data. Published annually (Means Company, Inc.)

Means Landscape Estimating. Published annually (Means Company, Inc.)

National Construction Estimator. Published annually. (Craftsman Book Company).

Lakes and Ponds

Allen, S.K. and R.J. Wattendorf. 1987. "Triploid grass carp: status and management implications". Fisheries. (12)4:20-24.

Aquatic Systems Engineering. 1990. Assessment and Guide for Meeting Dissolved Oxygen Water Quality Standards in Hydroelectric Plant Discharges. EPRI GS-7001. Electric Power Res. Inst., Palo Alto, CA.

Baker, J.P. et al. 1992. Fish and Fisheries Management in Lakes and Reservoirs. EPA 841-R-93-002. Terrene Institute and U.S. Environmental Protection Agency, Washington, DC.

Barnard, W.D. 1978. Prediction and Control of Dredged Material Dispersion Around Dredging and Openwater Pipeline Disposal Operations. Tech. Rep. DS-78-13. U.S. Army Corps of Engineers, Vicksburg, MS.

Barten, J.M. 1987. "Stormwater runoff treatment in a wetland filter: Effects on the water quality of Clear Lake". Lake Reservoir Manage. 3:297-305.

Benndorf, J. and K. Putz. 1987. "Control of eutrophication of lakes and reservoirs by means of pre-dams--I. Mode of operation and calculation of nutrient elimination capacity". Water Res. 21:829-838.

Carline, R.F. 1980. "Features of successful spawning site development for brook trout in Wisconsin ponds". Trans. Am. Fish Soc. 109:453-7.

Carpenter, S.R. and J.F. Kitchell. 1988 "Consumer control of lake productivity". Bioscience.

*Prototype Information Tree for Environmental
Restoration Plan Formulation and Cost Estimation*

Carpenter, S.R. and J.F. Kitchell. 1988 "Consumer control of lake productivity".
Bioscience. 38:764-769.

Conyers, D.L. and G.D. 20

Cooke. 1983. "A comparison of the costs of harvesting and herbicides and their effectiveness in nutrient removal and control of macrophyte biomass". In *Lake Restoration, Protection, and Management*. Proc. 2nd annual conf. N. Am. Lake Mange. Soc., Vancouver, B.C. EPA-440/5-83-001. U.S. Environmental Protection Agency.

Cooke, G.D. et al. 1986. *Lake and Reservoir Restoration*. Butterworth Publ., Stoneham, MA.

----- and R.E. Carlson. 1989. *Reservoir Management for Water Quality and THM Precursor Control*. American Waterworks Association Research Foundation, Denver, CO.

----- and R.H. Kennedy. 1989. "Water quality management in reservoirs and tailwaters". In *Reservoir Water Quality Management Techniques*. Tech. Rept. E-89-1. U.S. Army Corps of Engineers, Vicksburg, MS.

Everhart, W.H. and W.D. Youngs. 1981. *Principles of Fishery Science*. Cornell University Press, Ithaca, NY.

Fiala, I, and P. Vasata. 1982. "Phosphorous reduction in a man-made lake by means of small reservoir on the inflow". *Arch. Hyrdobiol.* 94:24-37.

Gulati, et al. 1990. *Biomanipulation: Tool for Water Management*. Kluwer, Boston, MA.

Hanson, M.J. and H.G. Stephan. 1984. "Side effects of fifty years of copper sulfate treatment of the Fairmont Lakes, Minnesota". *Water Res. Bull.* 20:889-90.

Hutto, T.D. and B.M. Sabol. 1986. "Application of HARVEST, mechanical simulation model, as an operational aquatic macrophyte management decision tool". *Lake Reserv. Manage.* 2:267-270.

Kitchell, J.F. (ed.). 1991. *Food Web Management: A Case Study of Lake Mendota, Wisconsin*. Springer-Verlag, New York, NY.

Kortmann, R.W. 1989. "Aeration: technologies and sizing methods". *Lake Line.* 9:6-19.

Mauldin, G. et al. 1988. "Injecting an oxygen fix". *Civil Eng.* March 1988:54-6.

***Prototype Information Tree for Environmental
Restoration Plan Formulation and Cost Estimation***

McQueen D. J. and D.S. Lean. 1986. "Hypolimnetic Aeration: An overview". *Water Poll. Res. Can.* 21:205-217.

National Research Council, 1992. *Restoration of Aquatic Ecosystems*. National Academy Press, Washington, DC.

Newroth, P.R. and R.J. Soar. 1986. "Eurasian watermilfoil management using newly developed technologies". *Lake Reserv. Manage.* 2:252-7.

Nicholson, S.A. 1981. "Changes in submersed macrophytes in Chautauqua Lake, 1937-1975". *Freshw. Biol.* 11:523-530.

Nurnberg, G.K. 1987. "Hypolimnetic withdrawal as a lake restoration technique". *J. Environ. Eng.* 113:1006-1017.

Olem, H. and G. Flock (eds.). 1990. *The lake and Reservoir Restoration Manual*. Second Edition. U.S. Environmental Protection Agency, EPA-440/4-90-006. (August).

Pastorek, R.A. et al. 1981. *Evaluation of Aeration/Circulation as a Lake Restoration Technique*. EPA-600/3-81-014. U.S. Environmental Protection Agency, Washington, DC.

Peterson, S.A. 1981. *Sediment Removal as a Lake Restoration Technique*. EPA-600/3-81-013, U.S. Environmental Protection Agency, Washington, DC.

-----, 1982a. "Dredging and nutrient inactivation as lake restoration techniques: a comparison". In *Management of Bottom Sediments Containing Toxic Substances: Proc. Sixth U.S./Japan Experts Meeting*. U.S. Army Corps of Engineers Dredging Oper. Tech. Support Program, Vicksburg, MS.

-----, 1982b. "Lake restoration by sediment removal". *Water Res. Bull.* 18:423-35.

Phillips, S.H. 1990. *A Guide to the Construction of Freshwater Artificial Reefs*. Artificial Reefs Dev. Center, Sport Fishing Inst. Washington, DC.

Prepas, E.E. et al. 1990. "Impact of liquid oxygen injection on a deep, naturally eutrophic lake: Amisk lake, Alberta, year one". *Ver. Int. Limnol.* 24:320.

Reddy, K.R. and T.A. DeBush. 1987. "State-of-the-art utilization of aquatic plants". *Water Pollut. Control, Water Sci. and Tech.* 19:61-79.

Ripl, W. 1976. "Biochemical oxidation of polluted lake sediment with nitrate: a new restoration

*Prototype Information Tree for Environmental
Restoration Plan Formulation and Cost Estimation*

Ripl, W. 1976. "Biochemical oxidation of polluted lake sediment with nitrate: a new restoration method". *Ambio* 5:132-44.

----- and G. Lindmark. 1978. "Ecosystem control by nitrogen metabolism in sediment". *Vatten* 34:135-44.

Shireman, J.V. 1982. "Cost analysis of aquatic weed control: fish versus chemicals in a Florida lake". *Progr. Fish-Cult.* 44:199-200.

Shireman, J.V. et al. 1982. *The Impact of Aquatic Plants and Their Management Techniques on the Aquatic Water Resources of the United States.* EPA-660/3-83-098. U.S. Environmental Protection Agency, Washington, DC.

Smith S.A. et al. 1975. *Aeration as a Lake Management Technique.* Tech. Bull. No. 87. Wisconsin Dept. Nat. Resour. Madison, WI.

Walker, W.W. 1987. "Phosphorous removal by urban runoff detention basins". *Lake Reservoir Manage.* 3:314-326.

Wedepohl, R.E. et al. 1990. *Monitoring Lake and Reservoir Restoration: Technical Supplement to The Lake and Reservoir Restoration Manual.* EPA-440/4-90-007, U.S. Environmental Protection Agency, Washington, DC. (August).

Westerdahl, H.E. and K.D. Getsinger (eds.). 1988. *Aquatic Plant Identification and Herbicide Use Guide: Volume I and II.* Aquatic plant Control Res. Progr. Tech. Rep. A-88-9. U.S. Army Corps of Engineers, Vicksburg, MS.

Willenbring, P.R. et al. 1984. "Reducing sediment phosphorous release rates in Long Lake through the use of calcium nitrate". In *Lake and Reservoir Management.* EPA-440/5-84-001. U.S. Environmental Protection Agency, Washington, DC.

Wirth, T. 1988. *Lake Aeration in Wisconsin lakes.* Lake Management Program PUBL-WR-196. Wisconsin Dept. of Nat. Res., Madison, WI.

Rivers and Streams

Berger, J.J. (ed) 1988. *Environmental restoration: Science and Strategies for Restoring the Earth.* Restoring the earth conference, Berkeley, Calif. Island Press. Washington D. C.

***Prototype Information Tree for Environmental
Restoration Plan Formulation and Cost Estimation***

- Duff, D. et al. 1988. Indexed Bibliography on Stream Habitat Improvement. 4th rev. Dept. Fisheries and Wildlife, College of Natural Resources, Utah State University, Logan.
- Gore, J.A. (ed.). 1985. The Restoration of Rivers and Streams: Theories and Experience. Butterworth, Stoneham, MA.
- House, R. et al. (eds), Stream Rehabilitation Manual Emphasizing Project Design, Construction and Evaluation. Oregon Chapter, Am. Fish. Soc.
- Hunt, R.L. 1988. A Compendium of 45 Trout Stream Habitat Development Evaluations in Wisconsin During 1953-1985. Tech. Bull. No. 162. WI Dept. of Nat. Res., Madison, WI.
- Hunter, C.J. 1991. Better Trout Habitat- A Guide to Stream Restoration and Management. Montana Land Reliance, Island Press, Washington D.C.
- Lisle, T. and K. Overton. 1990. "Utilizing channel information to reduce risk in developing habitat restoration projects." In R. House, J. Anderson, P. Boehne and J. Suther (eds), Stream rehabilitation manual emphasizing project design, construction, and evaluation. Sec. 5. Oregon Chapter, Am. Fish. Soc. 18p
- Macdonald, J.S. et al. 1988. "The effects of logging, other forest industries and forest management practices on fish: an initial bibliography." Can. Tech. Rep. Fish. Aquat. Sci. No. 1622.
- Payne, N.F. and F. Copes. 1986. Wildlife and Fisheries Habitat Improvement Handbook. USDA Forest Service; Wildlife and Fisheries Administration Rept. (Unnumbered)
- Rosgen, D.L. 1988. Conversion of a Braided River Pattern to Meandering: a Landmark Restoration Project". Presented at the CA Riparian Systems Conf., Sept. 2-24, Davis, CA.
- . 1988. "A stream classification system". In Restoration, Creation and Management of Wetland and Riparian Ecosystems in the American West. K.M. Muntz, et al. (eds.). PIC Technologies, Inc. and CRS Serrine, Inc. Denver, CO.
- and B.L. Fittante. 1986. Fish Habitat Structures--a Selection Guide Using Stream Classification. Proceedings of the fifth trout stream habitat improvement workshop, Lockhaven, PA.
- Wesche, T.A. 1985. "Stream channel modifications and reclamation structures to enhance fish habitat." p103-164. In J.A. Gore (ed), The restoration of rivers and streams.

*Prototype Information Tree for Environmental
Restoration Plan Formulation and Cost Estimation*

Wesche, T.A. 1985. "Stream channel modifications and reclamation structures to enhance fish habitat." pgs 103-164. In J.A. Gore (ed), The restoration of rivers and streams.

Wetlands

Aberle, B. 1990. "The Biology, Control, and Eradication of Introduced *Spartina* (cordgrass) Worldwide and Recommendations for its Control in Washington." Draft Report. Washington State Department of Natural Resources. Seattle.

Berger, J. (ed.). 1990. Ecological Restoration in the San Francisco Bay area: A Descriptive Directory and Source Book. Restoring the earth Inc., Berkeley, Calif.

-----, 1990. Environmental Restoration: Science and Strategies for Restoring the Earth. Island Press, Washington, DC.

Cairns, J. (ed.), 1988. Rehabilitating Damaged Ecosystems. Vol. 1. 192 pp.; Vol. 2. 222 pp. CRC Press, Boca Raton, Fla.

Connors, D.H. et al. 1990. Research Needs: Salt Marsh Restoration, Rehabilitation, and Creation Techniques for Caltrans Construction Projects." Dept. of Civil Engineering, University of California, Davis.

Covin, J.D. and J.B. Zedler. 1988. "Nitrogen effects on *spartina foliosa* and *salicornia virginica* in the salt marsh at Tiajuana estuary, Calif." Wetlands 8:51-65.

Dewald, J.M. and J.P. Rieger. 1982. Restoration of a Degraded Salt Marsh: Objectives and Techniques. Unpublished Report. California Dept. of Transportation, Caltrans district 11, San Diego.

Gosselink, J.G. et al. 1990. Ecological Processes and Cumulative Impacts. Lewis Publishers, Chelsea, Mich.

Hammer, D.A. 1992. Creating Freshwater Wetlands. Lewis Publishers. Chelsea, MI.

Kent, D.M. (ed.). 1994. Applied Wetlands Science and Technology. Lewis Pub., Boca Raton, FL.

Kusler, J.A., and M. Kentula, (eds). Wetland Creation and Restoration: The Status of Science. Vol. I and II. U.S. EPA 7600/3-89-/038. U.S. Environmental Protection Agency, Environmental Research Laboratory, Corvallis, Ore.

Lewis, R.R., 1981. Creation and Restoration of Coastal Plant Communities. CRC Press. Boca Raton. Fl.

***Prototype Information Tree for Environmental
Restoration Plan Formulation and Cost Estimation***

June.

Marble, A.D. 1991. A Guide to Wetland Functional Design. Lewis Publishers. CRC press. Boca Raton. Fl.

Mitsch, W.J. and S. Jorgensen, (eds.) 1989. Ecological Restoration: An Introduction to Ecotechnology. John Wiley and Sons, New York, NY.

Odum, W.E. 1988. "Predicting ecosystem development following creation and restoration of wetlands." In J. Zelazny and J. S. Feierabend, (eds), Increasing Our Wetland Resources. Conference Proceedings, National Wildlife Federation Corporate Conservation Council, October 4-7, 1987. NWF. Washington D. C.

Richardson, C.J. 1985. "Mechanisms controlling phosphorus retention capacity in freshwater wetlands." Science 228:1424-1427

Strickland, R. (ed). 1986. Wetland Functions, Rehabilitation, and Creation in the Pacific Northwest. Washington State Dept. of ecology, Olympia, Washington.

REPORT DOCUMENTATION PAGE

Form Approved
OMB No. 0704-0188

Public reporting burden for this collection of information is estimated to average 1 hour per response, including the time for reviewing instructions, searching existing data sources, gathering and maintaining the data needed, and completing and reviewing the collection of information. Send comments regarding this burden estimate or any other aspect of this collection of information, including suggestions for reducing this burden, to Washington Headquarters Services, Directorate for Information Operations and Reports, 1215 Jefferson Davis Highway, Suite 1204, Arlington, VA 22202-4302, and to the Office of Management and Budget, Paperwork Reduction Project (0704-0188), Washington, DC 20503.

1. AGENCY USE ONLY (Leave blank)	2. REPORT DATE March 1995	3. REPORT TYPE AND DATES COVERED
----------------------------------	------------------------------	----------------------------------

4. TITLE AND SUBTITLE Prototype Information Tree for Environmental Restoration Plan Formulation and Cost Estimation	5. FUNDING NUMBERS
--	--------------------

6. AUTHOR(S) Paul F. Scodari, Curtis C. Bohlen, and Amal Srivastava of King & Associates, Inc.	
---	--

7. PERFORMING ORGANIZATION NAME(S) AND ADDRESS(ES) U.S. Army Corps of Engineers, Water Resources Support Center, Institute for Water Resources, 7701 Telegraph Road, Alexandria, VA 22315-3868 and U.S. Army Corps of Engineers Waterways Experiment Station, 3909 Halls Ferry Road, Vicksburg, MS 39180-6199	8. PERFORMING ORGANIZATION REPORT NUMBER IWR Report 95-R-3
--	---

9. SPONSORING/MONITORING AGENCY NAME(S) AND ADDRESS(ES) Headquarters U.S. Army Corps of Engineers 20 Massachusetts Ave., NW Washington D.C. 20314-1000	10. SPONSORING/MONITORING AGENCY REPORT NUMBER
--	--

11. SUPPLEMENTARY NOTES Available from National Technical Information Service, 5285 Port Royal Road, Springfield, VA 22161

12a. DISTRIBUTION/AVAILABILITY STATEMENT Approved for Public Release; Distribution Unlimited.	12b. DISTRIBUTION CODE
---	------------------------

13. ABSTRACT (Maximum 200 words) This is the first of a series of interim reports which will be published for the Engineering Environmental Investments Work Unit in the Evaluation of Environmental Investments Research Program. This report investigates the possibility of developing an informational tool for organizing and providing the type of data and information necessary for identifying and costing environmental restoration measures and techniques. Other interim reports being prepared in this work unit will help build into this prototype effort.
--

14. SUBJECT TERMS Engineering, Costing, Lakes and Ponds, Rivers and Streams, Wetlands, Broad Problem Areas, Target Variables, Management Measures, Management Techniques	15. NUMBER OF PAGES 66
	16. PRICE CODE

17. SECURITY CLASSIFICATION OF REPORT UNCLASSIFIED	18. SECURITY CLASSIFICATION OF THIS PAGE UNCLASSIFIED	19. SECURITY CLASSIFICATION OF ABSTRACT UNCLASSIFIED	20. LIMITATION OF ABSTRACT Same as Report
---	--	---	--