

# A LIMITED EVALUATION OF THE TRAFFIC ALERT/COLLISION AVOIDANCE SYSTEM FOR T-1A CELL FORMATION STATION KEEPING (HAVE CELL)

A  
F  
F  
T  
C

ANDREW B. WHITE, III  
Captain, USAF  
Program Manager

EDWIN V. ODISHO, II  
Captain, USMC  
Project Pilot

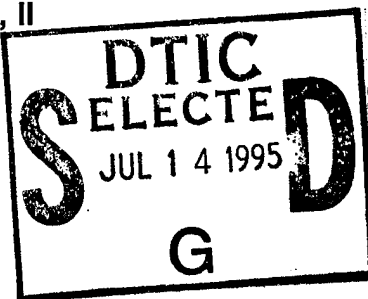

JUNE 1995

19950711 003

TECHNICAL LETTER REPORT

Approved for public release; distribution is unlimited. Other requests for this document shall be referred to USAF TPS/EDT, Edwards AFB, California 93524-6845.

Controlling Office: USAF TPS/EDT, Edwards AFB, California 93524-6845

AIR FORCE FLIGHT TEST CENTER  
EDWARDS AIR FORCE BASE, CALIFORNIA  
AIR FORCE MATERIEL COMMAND  
UNITED STATES AIR FORCE

This final report (AFFTC-TLR-95-36) was submitted under Job Order Number M94C1400 by the HAVE CELL Test Program Management Group, Class 94B, USAF Test Pilot School, Edwards AFB CA 93523 to ASC/YT, Wright-Patterson AFB OH.

Prepared by:

This report has been reviewed and approved for publication:  
9 June 1995

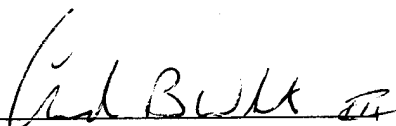
  
ANDREW B. WHITE III  
Captain, USAF  
Test Director

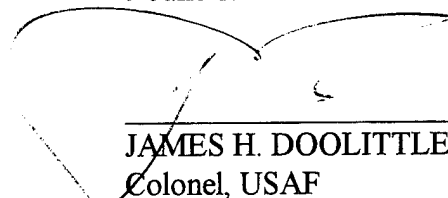
  
JAMES H. DOOLITTLE, III  
Colonel, USAF  
Commandant, USAF TPS

  
EDWIN V. ODISHO II  
Captain, USMC  
Project Pilot

  
TREVOR M. CLARK  
Captain, USAF  
Project Flight Test Navigator

  
DANIEL T. BAGLEY  
Captain, USAF  
Project Flight Test Engineer

  
DAVID J. MORGAN  
Captain, USAF  
Project Flight Test Engineer

# REPORT DOCUMENTATION PAGE

Form Approved  
OMB No. 0704-0188

Public reporting burden for this collection of information is estimated to average 1 hour per response, including the time for reviewing instructions, searching existing data sources, gathering and maintaining the data needed, and completing and reviewing the collection of information. Send comments regarding this burden estimate or any other aspect of this collection of information, including suggestion for reducing this burden, to Washington Headquarters Services, Directorate for Information Operations and Reports, 1215 Jefferson Davis Highway, Suite 1204, Arlington, VA 22202-4302, and to the Office of Management and Budget, Paperwork Reduction Project (0704-0188), Washington, DC 20503

1. AGENCY USE ONLY (Leave Blank)	2. REPORT DATE 9 June 95	3. REPORT TYPE AND DATES COVERED Technical Letter Report / 20 Jan - 6 Jun 1995	
4. TITLE AND SUBTITLE A Limited Evaluation of the Traffic Alert/Collision Avoidance System for T-1A Cell Formation Station-Keeping		5. FUNDING NUMBERS JON: M94C1400	
6. AUTHORS Bagley, Daniel T.; Clark, Trevor M.; Morgan, David J.; White, Andrew B. III, Capt USAF; Odisho, Edwin V. II, Capt USMC		8. PERFORMING ORGANIZATION REPORT NUMBER	
7. PERFORMING ORGANIZATION NAME(S) AND ADDRESS(ES) USAF TPS/EDB Edwards AFB, CA 93523-5000		10. SPONSORING / MONITORING AGENCY REPORT NUMBER  N/A	
9. SPONSORING / MONITORING AGENCY NAME(S) AND ADDRESS(ES) USAF TPS/CC Edwards AFB, CA 93523-5000		11. SUPPLEMENTARY NOTES NONE	
12a. DISTRIBUTION / AVAILABILITY STATEMENT Distribution unlimited		12b. DISTRIBUTION CODE  A	
13. ABSTRACT (Maximum 200 words) This report presents the results of a limited evaluation of the suitability of the T-1A's Traffic Alert / Collision Avoidance System (TCAS) for cell formation station-keeping procedures during instrument meteorological conditions. The TCAS system was evaluated during cell formation takeoff, climb, cruise, and descent. The accuracy of the TCAS in bearing, range and altitude was evaluated. The aircraft were flown through a high density traffic area to evaluate the effects of a high traffic density on TCAS performance characteristics during cell formation station-keeping. A safe cone of operation was defined. A workload study was accomplished to evaluate pilot workload while using TCAS to fly cell formation in the T-1A.			
14. SUBJECT TERMS  <u>Descriptors:</u> Collision Avoidance, Station-keeping, Station-keeping Equipment, Formation, Formation flight, Instrument Flight, Instrument Flying, IFF, IFF Systems, Transponders, Avionics, Air Traffic.  <u>Identifiers:</u> TCAS, TCAS 2, TCAS II, IFF, IFF Systems, IMC, Instrument Flight, IFF Systems Transponders, Instrument Flight Rules.			
17. SECURITY CLASSIFICATION OF REPORT  UNCLASSIFIED		15. NUMBER OF PAGES  63	
18. SECURITY  UNCLASSIFIED		16. PRICE CODE  N/A	
NSN 7540-01-280-5500	19. SECURITY CLASSIFICATION OF ABSTRACT  UNCLASSIFIED	20. LIMITATION OF ABSTRACT  UNLIMITED	

This page intentionally left blank.

## PREFACE

This report presents the results of an evaluation of the suitability of the T-1A's Traffic Alert/Collision Avoidance System for cell formation station-keeping procedures during instrument meteorological conditions. Testing was conducted at the Air Force Flight Test Center, Edwards Air Force Base CA as part of the Test Pilot School curriculum for Class 94B. This test was performed for the T-1A System Program Office, ASC/YT under Job Order Number M94C1400.

Sincere appreciation is expressed to Mrs. Gina Papa, 412TW/TSSH for her help in the human factors/workload evaluation, and Mr. Byron Biscoe, 412TW/TSRO for his help in obtaining radar traffic data during the high density traffic test. Also, gratitude is extended to Mr. Paul Romel, Mr. Johnny Siller, and Mr. Keith Holt of Beach Aerospace Services Incorporated for their superb aircraft maintenance support during this flight test program.

This page intentionally left blank.

## EXECUTIVE SUMMARY

Headquarters Air Education and Training Command (HQAETC) desired the capability to accomplish limited cell formation training with the T-1A Jayhawk in instrument meteorological conditions (IMC), using the Traffic Alert/Collision Avoidance System (TCAS).

Testing was conducted from 29 Mar 95 to 18 Apr 95 by five members of the United States Air Force Test Pilot School (USAF TPS) Class 94B, using two T-1A Jayhawks, provided by AETC. The general test objective was to evaluate the feasibility of using the TCAS to execute IMC trail formation procedures. The TCAS system was evaluated during takeoff, climb, cruise, and descent. Seven formation sorties, totaling 25.5 flight hours, were flown during this evaluation. Overall, the TCAS system was satisfactory for use during IMC cell formation procedures in the T-1A Jayhawk.

System performance characteristics during cell formation procedures were satisfactory. The TCAS position accuracy was satisfactory, and there were no antenna blanking problems which would impact normal cell formation operations. A safe operational envelope, compatible with current cell formation procedures, was determined. The TCAS operation in a high density traffic environment was satisfactory. Workload during simulated and actual IMC ranged from light, during straight and level flight, to high during unannounced maneuvering.

Recommend incorporating TCAS into current AETC cell procedures for limited IMC operations, pending results of further statistical analyses of TCAS position errors. No evaluation of operational cell formation procedures was performed due to the lack of established AETC TCAS cell formation procedures. A published set of procedures is necessary for operational use of the TCAS system for cell formation in actual IMC and should be established prior to operational employment of the system. To minimize pilot workload, inter-aircraft communications should be established and maintained during IMC operations. In addition, several recommendations to improve the TCAS display, warnings and cues were made.

Accession For	
NTIS CRA&I	<input checked="" type="checkbox"/>
DTIC TAB	<input type="checkbox"/>
Unannounced	<input type="checkbox"/>
Justification _____	
By _____	
Distribution /	
Availability Codes	
Dist	Avail and/or Special
A-1	

This page intentionally left blank.

## TABLE OF CONTENTS

	<u>Page No.</u>
PREFACE.....	i
EXECUTIVE SUMMARY.....	iii
LIST OF ILLUSTRATIONS.....	vii
INTRODUCTION.....	1
Background.....	1
Chronology.....	1
Test Item Description.....	1
Test Objectives.....	3
TEST AND EVALUATION.....	5
Test Procedures.....	5
Test Results.....	12
CONCLUSIONS AND RECOMMENDATIONS.....	21
REFERENCES.....	23
APPENDIX A.....	25
APPENDIX B.....	35
APPENDIX C.....	47
LIST OF ABBREVIATIONS AND SYMBOLS.....	53
DISTRIBUTION LIST.....	55

This page intentionally left blank.

## LIST OF ILLUSTRATIONS

<u>Figure</u>	<u>Title</u>	<u>Page No.</u>
1	TCAS Multifunction Display	2
2	HAVE CELL Enroute Stable Points, Accuracy Testing	6
3	HAVE CELL Climb Stable Points, Blanking Testing	7
4	HAVE CELL Descent Stable Points, Blanking Testing	8
5	TCAS Three-Dimensional Position Accuracy, One Standard Deviation Error	14
6	TCAS Safe Envelope of Operation	15
APPENDIX A		
A1	GPS Bearing Error	28
A2	GPS Range Error	29
A3	TCAS Bearing Accuracy	30
A4	TCAS Range Accuracy	31
A5	TCAS Altitude Accuracy	32
A6	TCAS High Density Traffic TECCS Depiction	33
APPENDIX B		
B1	Example TCAS Accuracy Photograph	39
B2	TCAS Bearing Error Distribution	40
B3	TCAS Range Error Distribution	41

This page intentionally left blank .

# INTRODUCTION

## BACKGROUND

Headquarters Air Education and Training Command (HQ AETC) requested the United States Air Force Test Pilot School (USAFTPS) investigate the station-keeping capabilities of the Traffic Alert/Collision Avoidance System (TCAS) for instrument flight rules (IFR) cell formations in the T-1A Jayhawk. This test was conducted by five members of TPS Class 94B under the authority of the USAFTPS Commandant. Testing was performed from 29 Mar to 18 Apr 95. Two T-1A Jayhawks (USAF serial numbers 90-0404 and 92-1633) provided by AETC were used in the testing. Seven formation sorties, totaling 25.5 flight hours, were flown during this evaluation.

Air Education and Training Command desired the capability to accomplish limited cell formation training with the T-1A Jayhawk in instrument meteorological conditions (IMC). At the time, air-to-air TACAN was used only in visual meteorological conditions (VMC), but not in IMC. In October 1994, Beechcraft Aircraft Company and the USAF accomplished a quick-look study using an enhanced TCAS display for T-1A cell formation station-keeping. During the single proof-of-concept flight test, the trail aircraft was able to maintain 1 nautical mile in-trail formation position with the lead aircraft using the TCAS system.

The TCAS system was evaluated during takeoff, climb, cruise, and descent. A T-1A instructor pilot occupied the right seat of each aircraft during all of the flights. One flight was flown outside the R-2508 complex, within the Los Angeles basin, in order to test the TCAS in a high density traffic environment. All flights originated from and ended at Edwards AFB California.

## CHRONOLOGY

The following gives a chronology of the test program:

Aircraft GPS Antenna Modification	20 - 24 March 1995
Technical Review Board	21 March 1995
Safety Review Board	21 March 1995
Flight Test	29 March - 18 April 1995
Aircraft GPS Antenna Demodification	19 - 22 April 1995
Technical Report Coordination Meeting	23 May 1995
Oral Presentation	6 June 1995
Technical Report TPS Commandant Signature	9 June 1995

## TEST ITEM DESCRIPTION

### Traffic alert/collision avoidance system (TCAS):

The TCAS incorporated in the Beechcraft T-1A Jayhawk was the primary test item. The TCAS was an airborne device that functioned independently of the ground-based air traffic control (ATC) system, and provided collision avoidance protection. The TCAS was built by Collins Commercial Avionics-Rockwell. The TCAS interrogated the transponders of nearby aircraft and provided a warning when the proximity of an aircraft was determined to be a safety

threat. The TCAS system was comprised of a multifunction display (MFD), the computer unit, a receiver/transmitter unit, a directional antenna located on the top of the aircraft, and an omnidirectional antenna located on the bottom of the aircraft. Surrounding traffic relative bearing and range information were displayed on the MFD TCAS traffic page as shown in Figure 1. The TCAS computer unit computed the relative position of the surrounding traffic by using the directional antenna for bearing information and the time between the TCAS interrogation and the transponder reply of the surrounding traffic for distance information. Transponder Mode C (altitude information only) was transmitted along with the reply.

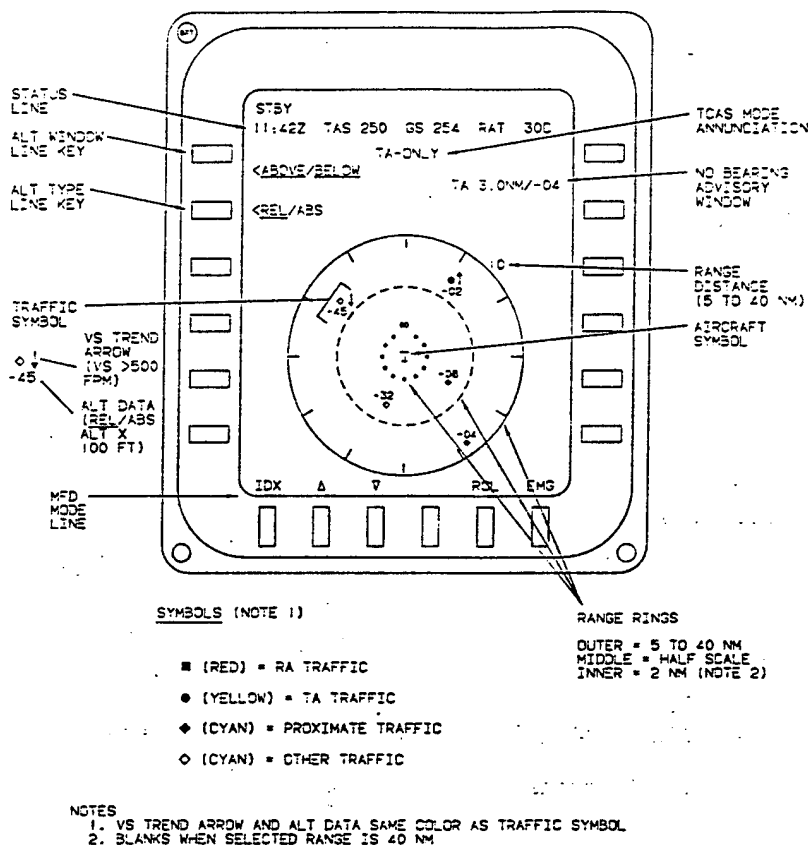

Figure 1 TCAS Multifunction Display (Reference 1)

The production TCAS full-scale range was variable from 5 to 40 nautical miles on the TCAS traffic page. For a detailed description of TCAS system operation, see Reference 2. The TCAS units under test were modified to display a 2 nautical mile scope. This modification was documented in a Contract Change Proposal for the TCAS system (Appendix C). This was the primary screen that was tested for station-keeping. Other than the 2 nautical mile range display modification, no software or hardware modifications were made, and the TCAS units used for this test were considered production representative.

### **Supporting aircraft:**

Two Beechcraft T-1A Jayhawks (USAF serial numbers 90-0404 and 92-1633) were flown for this evaluation. The T-1A was a swept-wing, high and low altitude, all-weather trainer. The normal training crew complement was three crewmembers (one instructor pilot and two student pilots). Two aft-mounted Pratt and Whitney JT15D-5B turbofan engines powered the T-1A. The T-1A also included speedbrakes, spoilers for roll control, a reversible flight control system, yaw damper, full span slotted Fowler flaps, retractable tricycle-type landing gear, nose wheel steering, and independent main gear anti-skid brakes (Reference 1). The T-1A test aircraft were modified by replacing the automatic direction finding (ADF) antenna with a global positioning system (GPS) blade antenna. Since the ADF was not required for navigation or other functions during this test, removal of the antenna did not impact normal aircraft operations. An antenna cable was routed from the GPS antenna to the passenger compartment. These modifications did not alter the aircraft's performance or handling qualities; therefore, the aircraft were considered production representative.

### **Instrumentation:**

Test instrumentation on each aircraft included a portable Garmin GPS100 GPS, incorporating coarse acquisition (C/A) code only, a NEC Versa E Series notebook computer, and either a VHS or 8mm video camera. All of the instrumentation units were battery-powered. The Garmin GPS100 units were used in each aircraft to obtain reference position data during flight testing. Position and time data from the GPS units were archived inflight on the NEC Versa E Series notebook computers by using a serial communication port. The data rate from the GPS was 1 sample every 2 seconds. The video camera was used to record the TCAS MFD and aircraft intercom/radio transmissions.

## **TEST OBJECTIVES**

The general test objective was to evaluate the feasibility of using the TCAS to execute IMC trail formation procedures in the T1-A Jayhawk.

The specific test objectives were to:

1. Quantitatively evaluate the T-1A TCAS system's performance when used for formation station-keeping procedures.
  - a. Evaluate the ability of the TCAS to display proper formation position within the area defined by the following limits: one nautical mile +/- 1/2 nautical miles aft of lead, 1,000 feet above to 1,000 feet below lead's position, and +/- 30 degrees lateral displacement.
  - b. Investigate in-trail positions for any regions of antenna blanking or performance degradations.
2. Qualitatively evaluate the ability to maintain in-trail formation position using TCAS in a high density traffic environment.
3. Qualitatively evaluate the TCAS display and warning cues for station-keeping operations.
4. Qualitatively evaluate pilot workload while using the TCAS for IMC station-keeping procedures.

All test objectives were met.

This page intentionally left blank.

# TEST AND EVALUATION

## TEST PROCEDURES

### General:

Testing was conducted using a buildup approach. Ridley time space position information (TSPI) data were obtained during the first flight to demonstrate the GPS accuracy. The GPS position data were used to determine the TCAS position accuracy and define areas of TCAS degradation or antenna blanking. The TCAS traffic prioritization logic was investigated with formation aircraft opening and closing maneuvers. In addition, one flight was conducted in a high-density traffic area to investigate potential interference problems that may be caused by other transponder-equipped aircraft. The TCAS displays and warning cues were evaluated during takeoff, turns, maneuvering, and simulated transponder failure. To assess pilot workload, the TCAS system was used by the trailing aircraft to maintain position on the lead aircraft while using an instrument flight rules (IFR) hood and performing IMC station-keeping procedures. In addition, an operationally representative mission was flown in actual IMC. Pilot comments were recorded on questionnaires and the actual workload was quantified using the Subjective Workload Assessment Technique (Reference 3).

### TCAS Accuracy:

Portable Garmin GPS100 GPS units (coarse acquisition code only) were used in each aircraft to obtain reference position data during flight testing. Position and time data from the GPS units were archived inflight on NEC Versa E Series notebook computers, using the GARMIN PC100 software (Reference 4), at 1 sample every 2 seconds. The GPS estimated position error (EPE) values were hand-recorded. GPS satellite status was determined prior to each flight. A GPS relative position error less than 300 feet and GPS EPE values within 20 percent of the actual error was considered adequate for TCAS accuracy testing. In addition, battery-operated video cameras were used to record the TCAS MFD and aircraft intercom and radio transmissions.

The Ridley Mission Control Center (RMCC) FPS-16 range radar was used on the first flight to demonstrate that the GPS units were capable of providing accurate position data. Ridley provided the test team with a postmission file containing universal time code (UTC) time, latitude, longitude, and altitude information at approximately two samples per second for both aircraft. Using a computer program developed by the test team (Appendix B), the GPS relative position accuracy was evaluated by comparing GPS position and time data with RMCC radar TSPI. The RMCC radar TSPI data were accurate to within approximately 50 feet using skin tracking.

For TCAS accuracy testing, a battery-operated video camera was used to record the TCAS MFD and the aircraft intercom and radio transmissions. The video camera was used with the time-on-tape feature to correlate flight events in UTC time between the two aircraft. The GPS units provided position reference information for evaluating TCAS position accuracy. Using a computer program developed by the test team (Appendix B), the TCAS position accuracy was evaluated by comparing TCAS relative range, bearing and time information with GPS position and time data. Data were collected for several relative aircraft positions in order to evaluate spatial correlation of the errors. Figure 2 depicts the TCAS accuracy testing data band and stable test points.

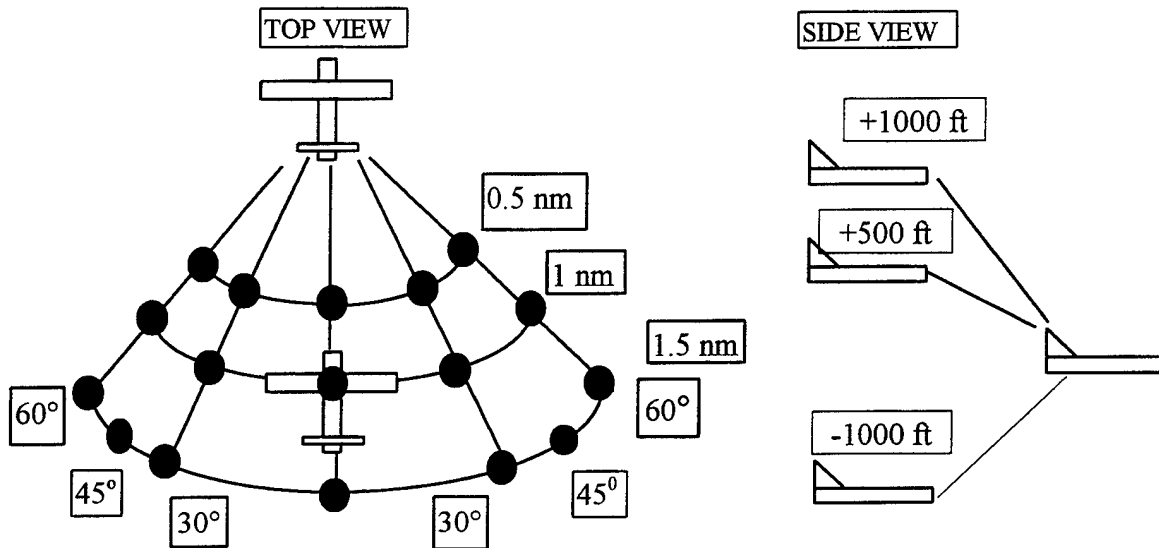

Figure 2 HAVE CELL Enroute Stable Points, Accuracy Testing

The TCAS in both aircraft were set up in the traffic advisory (TA) mode with the 2 nautical mile range display. Both aircraft barometric altimeters were set to 29.92 inches of mercury. The lead aircraft called the base heading and stabilized at 250 KIAS  $\pm$  10 knots and 20,000 feet pressure altitude (PA)  $\pm$  500 feet. To maintain a stable airspeed and altitude, the lead aircraft engaged the autopilot. The wingman maneuvered to the points depicted in Figure 2. When the wingman called "Stable" over the radio, data were recorded for that stable point. The airspeed and altitude tolerances for both lead and the wingman were  $\pm$  5 knots and  $\pm$  100 feet, respectively. The tolerances for the wingman were  $\pm$  1000 feet in-trail and  $\pm$  5 degrees of azimuth from the desired stable position. The TCAS system was designed so that if it stopped receiving transponder replies from a displayed traffic target, the TCAS would enter a coast mode for that aircraft (Reference 1). After 6 seconds of coasting with no transponder replies, the target would disappear from the display. The TCAS gave no indication to the aircrew when it was operating in the coast mode. To ensure potential blanking was not masked by the TCAS coast feature, the wingman stabilized on test conditions for 15 seconds. Each aircraft recorded the time when stable, GPS positions, GPS EPE values, aircraft magnetic headings, barometric altitude, and TCAS relative altitude. In addition, the TCAS displays were videotaped. The magnetic variation for the region of testing was applied to the wingman's magnetic heading to determine the aircraft true heading. The wingman's true heading and GPS position data were entered into a computer program developed by the test team (Appendix B) to determine the bearing and range between the aircraft. The TCAS display video of the stable points were converted into still photographs for postmission analysis. The bearings and ranges depicted on the TCAS display photographs

were compared to the GPS data, and the difference between the lead and wingman barometric altitudes were compared to the TCAS relative altitude.

**Antenna blanking:**

Antenna blanking and performance degradation were investigated during climb, enroute cruise, and enroute descent. Maximum continuous thrust (MCT) minus 5 percent  $N_1$  (percent engine fan speed in rotations per minute, Reference 1) in-trail formation climbs were performed from 7,000 to 20,000 feet PA. The TCAS in both aircraft were set up in the TA mode with the 2 nautical mile range display. Both aircraft barometric altimeters were set to 29.92 inches of mercury. Figure 3 depicts the wingman's position data band during the climb. The tolerances for the wingman were  $\pm 1,000$  feet in-trail and  $\pm 5$  degrees of azimuth from the desired stable position. To ensure potential blanking was not masked by the TCAS coast feature, the wingman maintained stable test conditions for 15 seconds.

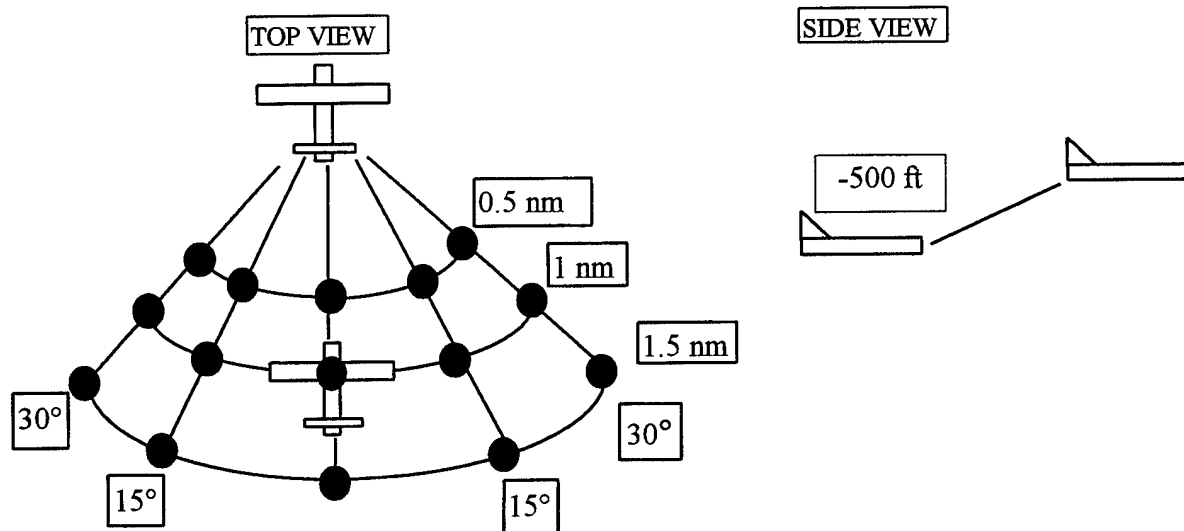

Figure 3 HAVE CELL Climb Stable Points, Blanking Testing

The lead aircraft called the climb base heading and climbed at 220 KIAS. The data band was  $\pm 5$  knots with a  $\pm 3$  knot tolerance. To maintain a stable climb airspeed, the lead aircraft engaged the autopilot. The lead aircraft made altitude calls every 1,000 feet. Once at the desired position, the wingman called "Stable" over the radio. Each aircraft recorded the time when stable, GPS positions, GPS EPE values, and videotaped the TCAS displays. The GPS position data were used to define precisely the wingman's relative position from lead if antenna blanking occurred.

While performing TCAS accuracy testing, straight and level enroute cruise antenna blanking was also investigated. In addition to the TCAS accuracy test points, the wingman stabilized 1 nautical mile abeam (both left and right) and co-altitude with lead. Then, the wingman stabilized 1 nautical mile abeam (both left and right) and 1,500 feet above and below lead. Finally, the wingman stabilized 1,500 feet directly above and below lead. The TCAS in both aircraft were set up in the TA mode with the 2 nautical mile range display. Both aircraft barometric altimeters

were set to 29.92 inches of mercury. The lead aircraft called the base heading and stabilized at 250 KIAS  $\pm$  10 knots and 20,000 feet PA  $\pm$  500 feet. To maintain a stable airspeed and altitude, the lead aircraft engaged the autopilot. To ensure potential blanking was not masked by the TCAS coast mode, the wingman maintained on conditions for 15 seconds. Each aircraft recorded the time when stable, GPS positions, GPS EPE values, and videotaped the TCAS displays. The GPS position data were used to define precisely the wingman's relative position from lead if antenna blanking occurred.

In-trail turns using 20, 30, and 45 degrees of bank were performed to investigate antenna blanking while maneuvering. The TCAS in both aircraft were set up in the TA mode with the 2 nautical mile range display. Both aircraft barometric altimeters were set to 29.92 inches of mercury. The lead aircraft announced the turn over the radio by stating the angle of bank and direction of the turn. Both 90 and 180 degree turns were performed at 20,000 feet PA  $\pm$  500 feet and 250 KIAS  $\pm$  10 knots. With 20 and 30 degrees of bank, the lead aircraft either hand-flew or used the autopilot to accomplish the turns. Forty-five degree banked turns were hand-flown. The wingman delayed the turn based on true airspeed and in-trail distance from the lead aircraft. Each aircraft recorded the turn start time, GPS positions, and videotaped the TCAS displays.

Enroute descents were accomplished from 20,000 to 7,000 feet PA to investigate antenna blanking. The TCAS in both aircraft were set up in the TA mode with the 2 nautical mile range display. Both aircraft barometric altimeters were set to 29.92 inches of mercury. Figure 4 depicts wingman's position data band during the descent. The tolerances for the wingman were  $\pm$  1000 feet in-trail and  $\pm$  5 degrees of azimuth from the desired stable position. To ensure potential blanking was not masked by the TCAS coast mode, the wingman maintained stable test conditions for 15 seconds.

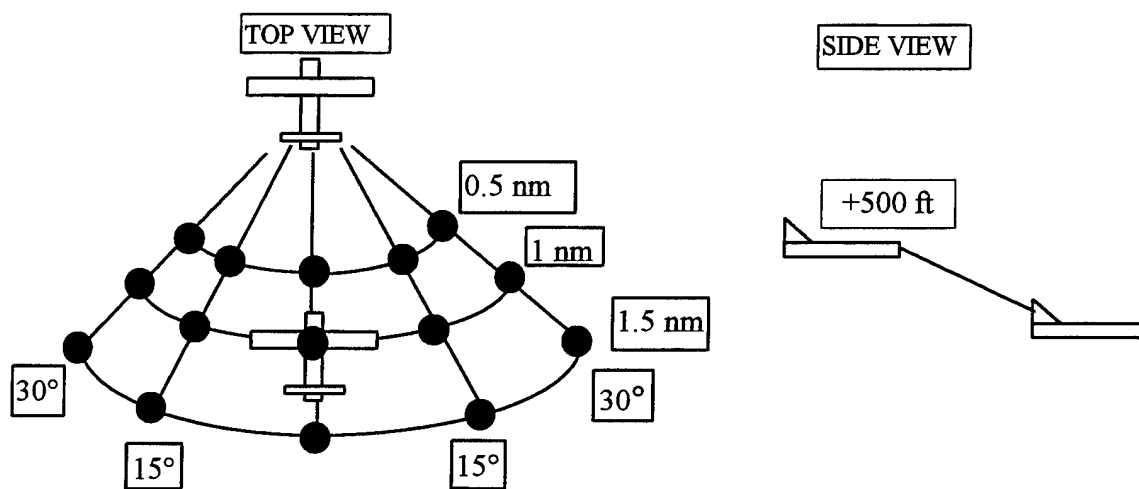

Figure 4 HAVE CELL Descent Stable Points, Blanking Testing

The lead aircraft called the base heading, set power to 60 percent  $N_1$ , and maintained 250 KIAS. During the descent the data band was  $\pm$  5 knots with a  $\pm$  3 knot tolerance. To maintain a stable descent airspeed, the lead aircraft engaged the autopilot. The lead made altitude calls every 1,000 feet. Once at the desired position, the wingman called "Stable" over the radio. Each aircraft recorded the time when stable, GPS positions, GPS EPE values, and videotaped the

TCAS displays. The GPS position data were used to define precisely the wingman's relative position from lead if antenna blanking occurred.

**Prioritization testing, high density environment:**

Opening and closing maneuvers were flown to investigate the TCAS traffic prioritization logic. The TCAS in both aircraft were set up in the TA mode with the 2 nautical mile range display. Both aircraft barometric altimeters were set to 29.92 inches of mercury for prioritization testing and to local altimeter setting for high density environment testing. Using the autopilot, the lead aircraft maintained 250 KIAS  $\pm$  10 knots and 20,000 feet PA  $\pm$  500 feet. The wingman started 0.5 nautical miles aft and 1,000 feet above lead, and then decelerated to 25 knots of opening velocity. The maneuver was terminated when the wingman reached 1.5 nautical miles aft of lead. Each aircraft videotaped the TCAS display to observe potential degradations or formation aircraft dropouts. The opening maneuver was repeated at 50 knots of opening velocity. Next, closing maneuvers were performed. As in the opening maneuvers, the TCAS in both aircraft were set up in the TA mode with the 2 nautical mile range display, and the lead aircraft used the autopilot to maintain 250 KIAS  $\pm$  10 knots and 20,000 feet PA  $\pm$  500 feet. The wingman started 1.5 nautical miles aft and 1,000 feet above lead, and then accelerated to 25 knots of closure. The air-to-air TACAN relative velocity was used to monitor the closure rate. The maneuver was terminated when the wingman was 1,000 feet aft of lead. The closing maneuver was repeated at 35 and 50 knots of closure. Each aircraft videotaped the TCAS display.

Air Education and Training Command cell formation procedures (wingman 1 nautical mile aft and 500 feet above lead) were used while flying in the Los Angeles approach low-altitude airway structure. Emphasis was placed on the wingman's ability to recognize the lead aircraft and investigate any interference from other traffic. The wingman used the TCAS display in the 2 nautical mile range, while the lead aircraft used the 40 nautical mile range to aid in traffic clearing. The wingman pilot flew the mission with an instrument flight rules (IFR) hood. The TCAS displays in each aircraft were videotaped. RMCC provided a videotape and computer printouts showing traffic summaries of the mission.

**Displays, warning cues:**

For takeoff, the TCAS in both aircraft were set up in the TA mode with the 2 nautical mile range display. Both aircraft barometric altimeters were set to 29.92 inches of mercury. Also, the air-to-air (A/A) TACAN systems were set up between the aircraft to backup the TCAS information and to use the A/A TACAN relative velocity function. For the runway lineup, the lead T-1A was positioned on the right side of the runway, while the wingman T-1A was positioned on the left side of the runway. The nose of the wingman was aligned with the tail of the lead aircraft with at least 30 feet of lateral wingtip clearance. Lead called for engine run-up to 80 percent  $N_1$ . When the wingman signaled ready, lead released brakes. The wingman started the takeoff roll 20 seconds after lead's brake release. A 20-second interval was chosen to reduce the time required for the wingman to rejoin 1 nautical mile in-trail. Each aircraft recorded the GPS EPE at takeoff. After weight-off-wheels in each individual aircraft, timing was started to determine when the formation appeared on the TCAS displays. In addition, the wingman in-trail spacing was recorded at the point when the formation appeared on the TCAS display. During the initial climb-out, altimeters were set to 29.92 inches of mercury. Lead accelerated to 220 KIAS and climbed to 7,000 feet PA. The wingman rejoined to 1 nautical mile in-trail at 6,000 feet PA.

If the wingman established position prior to the lead aircraft reaching 7,000 feet PA, then the climb to 20,000 feet PA was started immediately. For the first three sorties, takeoffs were accomplished with the wingman using the TCAS, A/A TACAN, and outside visual cues to rejoin on the lead aircraft. On subsequent missions, the wingman pilot used an IFR hood after passing 300 feet above ground level (AGL) to simulate IMC.

The TCAS display lateral displacement resolution was evaluated by the lead aircraft maintaining 250 KIAS  $\pm$  10 knots and 20,000 feet PA  $\pm$  500 feet using the autopilot. The TCAS in both aircraft were set up in the TA mode with the 2 nautical mile range display. Both aircraft barometric altimeters were set to 29.92 inches of mercury. The wingman set up 1 nautical miles aft and 500 feet above lead. The wingman used 5 degrees of bank to start a slow lateral movement. Timing was started when the maneuver was initiated, and timing was stopped when movement was recognized on the TCAS display. The maneuver was accomplished in both directions. The TCAS display was videotaped, and GPS position data were recorded. A similar procedure was performed to evaluate the utility of the TCAS display for turn recognition.

Both 90 and 180 degree turns were performed at 20,000 feet PA  $\pm$  500 feet and 250 KIAS  $\pm$  10 knots using 20, 30, and 45 degrees of bank. The lead aircraft announced the turn over the radio by stating the angle of bank and direction of the turn. With 20 and 30 degrees of bank, the lead aircraft pilot either hand-flew or used the autopilot to accomplish the turns. Forty-five degree banked turns were hand-flown. The wingman started timing when the lead aircraft announced "Turning" and timing was stopped when lead's turn was recognized on the TCAS display. The maneuver was accomplished in both directions. The wingman delayed the turn based on true airspeed and in-trail distance from the lead aircraft. Each aircraft recorded the turn start time, turn end time, GPS positions, and video-taped the TCAS displays. Unannounced turns were performed also to evaluate the wingman's ability to maintain formation using only the TCAS display.

Wingman opening and closing maneuvers were flown to investigate the TCAS display update rate. First, opening maneuvers were performed. The TCAS in both aircraft were set up in the TA mode with the 2 nautical mile range display. Both aircraft barometric altimeters were set to 29.92 inches of mercury. Using the auto-pilot, the lead aircraft maintained 250 KIAS  $\pm$  10 knots and 20,000 feet PA  $\pm$  500 feet. The wingman started 0.5 nautical miles aft and 1,000 feet above lead, and then decelerated to 25 knots of opening velocity. The A/A TACAN relative velocity was used to monitor the opening rate. Each aircraft video-taped the TCAS display. The maneuver was terminated when the wingman reached 1.5 nautical miles aft of lead. The opening maneuver was repeated for 50 knots of opening velocity. Next, closing maneuvers were performed. As in the opening maneuvers, the TCAS in both aircraft were set up in the TA mode with the two nautical mile range display, aircraft barometric altimeters were set to 29.92 inches of mercury, and the lead aircraft used the auto-pilot to maintain 250 KIAS  $\pm$  10 knots and 20,000 feet PA  $\pm$  500 feet. The wingman started 1.5 nautical miles aft and 1,000 feet above lead, and then accelerated to 25 knots of closure. The A/A TACAN relative velocity was used to monitor the closure rate. The maneuver was terminated when the wingman reached 1,000 feet aft of lead. The closing maneuver was repeated for 35 and 50 knots of closure. Each aircraft video-taped the TCAS display.

TCAS failure was simulated by the lead aircraft turning off the transponder for 30 seconds. Prior to turning the transponder off, the TCAS in both aircraft were set up in the TA mode with the two nautical mile range display. Both aircraft barometric altimeters were set to 29.92 inches

of mercury. The lead aircraft maintained 250 KIAS  $\pm$  10 knots and 20,000 feet PA  $\pm$  500 feet using the auto-pilot. The wingman stabilized one nautical mile directly aft and 500 feet above the lead aircraft. At the lead's call, the lead's transponder was turned off, and timing was started. The time between turn-off and when lead's symbol disappeared from the wingman's TCAS screen was recorded in the wing aircraft. Each aircraft video-taped the TCAS displays to observe the target dropout and any warning cues.

### **Workload assessment:**

Pilot workload was assessed for all operationally representative maneuvers. The two test pilots were both former operational C-130 pilots. One had extensive experience in Station Keeping Equipment (SKE) formation procedures. These procedures were similar to the station-keeping procedures used in this test. The other pilot had no SKE or formation station-keeping experience.

Pilot comments were recorded and the actual workload was quantified using the Subjective Workload Assessment Technique (SWAT). The SWAT was developed by the Workload and Ergonomics Branch of the Armstrong Laboratories at Wright-Patterson in the early 1980s. It was a systematically developed and validated subjective measure specifically designed to assess mental workload (Reference 3).

Mental workload was proposed to be a multidimensional construct comprised of three component factors: time load, mental effort load, and psychological stress load. In addition, SWAT further defined three levels for each of the component factors roughly corresponding to high, medium, and low loading. The component factors were defined as:

**Time Load:** That fraction of the total time the pilot was busy.

**Mental Effort Load:** The amount of attention and concentration required to perform the task.

**Psychological Stress Load:** The presence of confusion, frustration, or anxiety which caused a need for greater concentration and determination.

A card sort procedure was accomplished by the two test pilots prior to flying the first mission. There were 27 cards which corresponded to each combination of workload rating. These cards were ordered according to which component factor the subject believed contributed most significantly to his perception of mental workload. The net result was an interval workload scale ranging from zero to 100. The SWAT card sort performed by the two test pilots revealed that psychological stress load was the most significant factor in their perception of workload.

The SWAT card sort was analyzed using the SWAT computer program. Group scaling was achieved from the results. For group scaling, the card sort data from the pilots were averaged together, and a conjoint analysis derived a single scale for the group based on a statistic known as Kendall's Coefficient of Concordance. In order for the use of group scaling to be valid, the Kendall's statistic was required to be greater than 0.75. Prior to flight test, the Kendall's statistic for the two test pilots was 0.99; therefore, their perception of mental workload was very closely aligned.

To determine the pilots' perception of workload, the test pilots provided a SWAT rating for individual operationally representative tasks. The SWAT rating was converted to a SWAT value determined from the interval workload scale produced by the computer program. Research has indicated that the "red line" measure for SWAT is between 30 and 50. This means that depending upon the amount of time required to complete the task (called dwell time), performance

degradation will occur at or around this point over time. More information on SWAT can be found in Reference 3.

An entire mission profile was flown in simulated and actual IMC for workload assessment. No video cameras or GPS unit were used for the flight in IMC.

For takeoff, the TCAS in both aircraft were setup in the TA mode with the two nautical mile range display. Also, the A/A TACAN system was set up between the aircraft to back up the TCAS information and use the A/A TACAN relative velocity function. For the runway lineup, the lead T-1A was positioned on the right side of the runway while the wingman T-1A was positioned on the left side of the runway. The nose of the wingman was aligned with the tail of the lead aircraft with at least 30 feet of lateral wing tip clearance. Lead called for engine run-up to 80%  $N_1$ . When the wingman signaled ready, lead released brakes. The wingman started the takeoff roll 20 seconds after lead's brake release. The wingman pilot used an IFR hood after passing 300 feet AGL to simulate IMC. Pilot workload was assessed for all simulated IMC takeoffs using the SWAT rating system. During the climbout, altimeters were set to 29.92 inches of mercury. Lead accelerated to 220 KIAS and climbed to 7,000 PA. Wing promptly rejoined to one nautical mile in-trail, 6,000 feet PA. If the wingman established position prior to the lead aircraft reaching 7,000 feet PA, then the climb to 20,000 feet PA was started immediately.

Next, a maximum continuous thrust (MCT) minus 5 percent  $N_1$  in-trail formation climb was performed from 7,000 to 20,000 feet PA. During the climb, the wingman maintained 1 nautical mile in-trail and 500 feet below lead's altitude using the TCAS and A/A TACAN. The tolerances for the wingman were  $\pm 1000$  feet in-trail and  $\pm 5$  degrees of azimuth. The lead aircraft called the climb base heading and climbed at 220 KIAS. The data band was  $\pm 5$  knots with a  $\pm 3$  knot tolerance. To maintain a stable climb airspeed, the lead aircraft engaged the auto-pilot. The lead made altitude calls every 1,000 feet. Pilot workload was assessed with the SWAT rating system. The actual level-off altitude was determined by height of the cloud decks.

Once in IMC, the lead aircraft leveled off and maintained 250 KIAS  $\pm 10$  knots. The wingman maintained one nautical mile in-trail and 500 above lead's altitude. The tolerances for the wingman were  $\pm 1000$  feet in-trail,  $\pm 100$  feet for altitude, and  $\pm 5$  degrees of azimuth. The lead aircraft performed announced and unannounced in-trail 30 degree banked turns. The wingman used timing and the TCAS to maintain formation position. Pilot workload was assessed with the SWAT rating system.

Finally, an enroute descent to 7,000 feet PA was accomplished in IMC. The lead aircraft called the base heading, set power to 60 percent  $N_1$ , and descended at 250 KIAS. The data band was  $\pm 5$  knots with a  $\pm 3$  knot tolerance. To maintain a stable descent airspeed, the lead aircraft engaged the auto-pilot. The lead made altitude calls every 1,000 feet. The wingman maintained one nautical mile in-trail and 500 above lead's altitude using the TCAS and A/A TACAN relative velocity information. The tolerances for the wingman were  $\pm 1000$  feet in-trail and  $\pm 5$  degrees of azimuth. Pilot workload was assessed with the SWAT rating system.

## TEST RESULTS

All test objectives were met. The TCAS was satisfactory to execute IMC trail formation procedures for the T-1A Jayhawk. The TCAS accuracy in displaying aircraft relative position within the normal cell formation envelope was satisfactory. Regions of blanking were found only on the lead's display when the wingman was within 0.8 miles aft and 800 feet or more below lead.

No blanking occurred on the wingman's display. The TCAS display and warning cues were satisfactory for station-keeping operations, although some minor areas of improvements for displays and cues were identified. The pilot's ability to maintain cell formation position using the TCAS in a high density environment was satisfactory. Pilot workload was satisfactory while using TCAS for IMC station-keeping procedures. Overall, the TCAS was satisfactory for use in transiting through IMC. The TCAS was not evaluated for use during extended IMC operations; therefore, the following recommendation applies to the use of TCAS to penetrate and pass through IMC only.

The accuracy of the TCAS system was evaluated for only two specific units, assumed to be production representative, among a fleet of units currently in use. In order to ensure that test results for this small sample size were representative of the entire population statistics, it is necessary to examine position accuracies for a larger sample size. This analysis could be accomplished using contractor-provided system error analyses to ensure the error values determined from this evaluation are consistent with errors exhibited by the entire fleet of systems. These data are important to ensure that the TCAS can be used to maintain proper cell formation position within the established safe envelope of operation. **Incorporate the use of TCAS into current AETC cell procedures for limited IMC operations, pending results of a statistical error analysis of a larger sample size of TCAS units. (R1)<sup>1</sup>**

No evaluation of operational maneuvers was accomplished due to the lack of established procedures for station-keeping using the TCAS. The current AETC cell formation procedures were used whenever feasible during the course of testing. A set of established procedures are required for operational use of this system in actual IMC, with specific emphasis on lost wingman procedures and positive altitude separation. **Establish and verify procedures, to include positive altitude separation, for T-1A cell formation using the TCAS in IMC. (R2)**

Other recommendations to improve the performance and human factors integration of the TCAS system were made also. The numeral following the recommendation indicates the priority given to the recommendation by the test team. Recommendations 1-3 are the most important and should be implemented together. The other recommendations address potential areas of improvement which, while not necessary for safe operation of the system, would enhance the system's operational utility.

The TCAS system was not evaluated in moderate precipitation or icing conditions. If use in adverse weather is required, system performance characteristics should be determined prior to operating in such conditions. System utility for formation station-keeping in adverse weather should be evaluated to ensure no degradations exist which would impact normal cell formation procedures. **Evaluate system performance in adverse weather, to include moderate precipitation and/or icing, if operation in such conditions is required. (R4)**

**Demonstration of GPS relative position accuracy:**

The GPS position was accurate to within 112 feet relative range and 0.54 degrees relative bearing, as shown in Figures A1 and A2. For a discussion of GPS position accuracy evaluation, see Appendix B.

---

<sup>1</sup> Numerals preceded by an R within parentheses at the end of a paragraph correspond to the recommendation numbers tabulated in the Conclusions and Recommendations section of this report.

**TCAS Accuracy:**

The position accuracy of the TCAS display was satisfactory for use during cell formation station-keeping. The TCAS range and bearing accuracy was determined by comparing photos of the TCAS display to GPS position data obtained during the stable points. The TCAS altitude accuracy was determined by comparing TCAS-displayed relative altitude with aircraft barometric altimeter readings. Details of the analysis methods are presented in Appendix B. The measured range, bearing, and altitude errors obtained during stable test points are presented in Table A1.

a. Bearing Accuracy -- Statistical analysis of the TCAS bearing errors using MATLAB (Reference 5) indicated a normal error distribution with zero mean and a one standard deviation value of 6 degrees (approximately 63 percent of errors were less than 6 degrees). Figure A3 shows the error plots for TCAS bearing accuracy

b. Range Accuracy -- Analysis of the stable points indicated a TCAS range error of less than 600 feet for all test points, with the exception of a single test point which indicated a 1,500 foot error. Statistical analysis of these data indicated a normal distribution, with -170 foot mean and a one standard deviation value of 240 feet. Figure A4 shows the error plots for TCAS range accuracy.

c. Altitude Accuracy -- Altitude accuracy was determined by comparing the TCAS-computed relative altitude, displayed on the TCAS MFD during the stable points, and a reference altitude difference computed by subtracting the two aircrafts' barometric altimeter readings. Both altimeters were set to 29.92 inches for the stable points. TCAS altitude errors exhibited a one standard deviation value of 80 feet. Figure A5 shows a plot of TCAS altitude errors exhibited by both TCAS systems. Data were plotted for all stable points, with relative altitudes ranging from -1,000 to +1,000 feet.

The three-dimensional position accuracy for the TCAS system is illustrated in Figure 5. The diagram shows the one standard deviation error values for range, bearing or aspect, and altitude. TCAS position accuracy was satisfactory for station-keeping in cell formation.

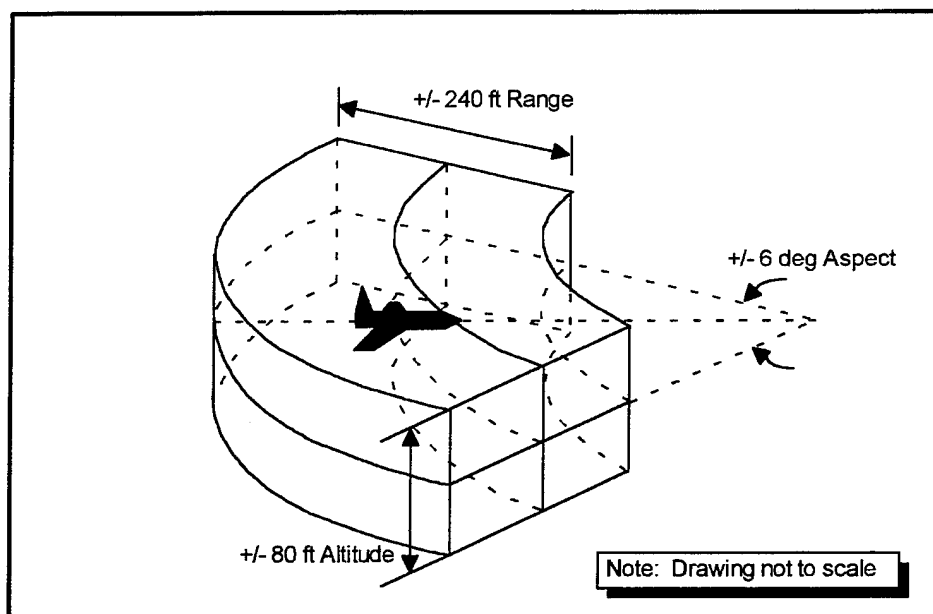

Figure 5 TCAS Three-Dimensional Accuracy, One Standard Deviation Error

**Antenna blanking:**

No antenna blanking or degradations which would impact using TCAS for cell formation station-keeping were observed. For the purposes of this evaluation, antenna blanking, or “blanking” was defined as a situation wherein either aircraft’s TCAS symbol disappeared from the other’s screen with TCAS and IFF transponders operating normally. The TCAS system exhibited no antenna blanking for the wing aircraft during normal trail operations, including climbs, turns, and descents. However, blanking was noted on the lead aircraft’s display when the wingman approached close to and below the lead’s position, and only when both aircraft were very stable. If the wingman was between 700 and 1,500 feet below lead and within 0.5 nautical mile, as soon as either aircraft established a relative position rate, the TCAS symbol reappeared on lead’s screen. However, if the wingman was more than 1,500 feet below lead, the TCAS symbol did not reappear. The only time the lead aircraft disappeared from the wingman’s TCAS screen was during the position limits test, when the wingman was 1,500 feet directly above lead. Overall, the TCAS system exhibited safe, consistent operation within a trail envelope defined by the position limits shown in Table 1.

Table 1 TCAS Safe Operational Envelope

Wingman Altitude Relative to Lead	Safe Operational Cone
-1,000 to 0 feet	>0.8 nm, +/-60° aspect
0 to 1,000 feet	>0.5 nm, +/-60° aspect

Figure 6 shows a schematic diagram for this recommended envelope.

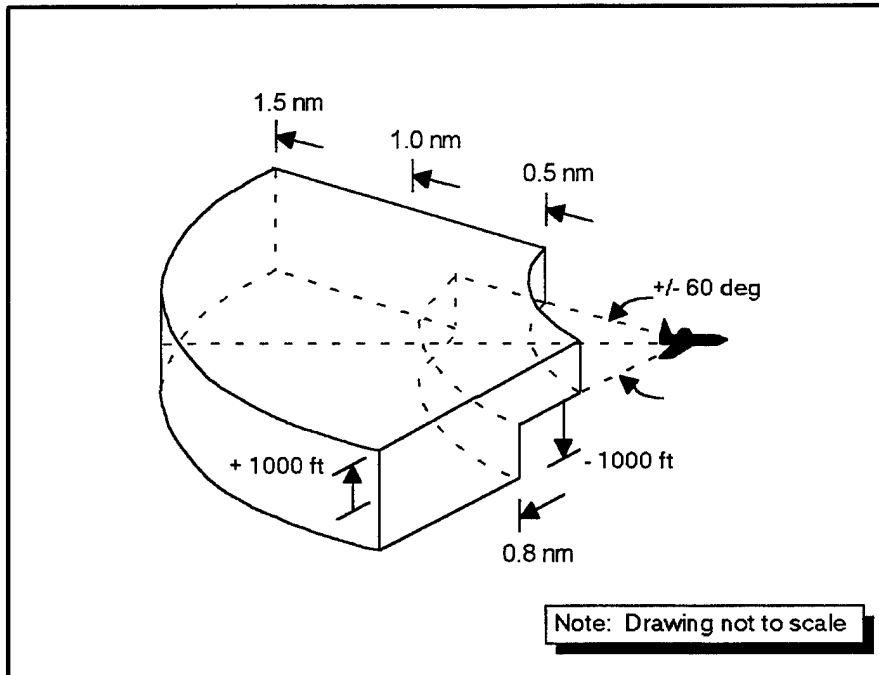

Figure 6 TCAS Safe Envelope of Operation

### **Prioritization testing, high density environment:**

The TCAS prioritization characteristics and operation during high density traffic conditions were satisfactory. The wing aircraft performed several opening and closing maneuvers using various rates to evaluate the update and prioritization characteristics of the TCAS system. The refresh rate of the TCAS system was adequate for all of the airspeeds tested -- up to 50 knots of closing velocity. There were no dropouts or anomalies observed in the lead or wing aircraft during this portion of the testing. The TCAS prioritization system was of some concern because the system was built for traffic avoidance, and the software logic was built around the idea that an aircraft that is a potential conflict would get the most attention from the system. This software logic was tested at various times while in the R-2508 complex. On three separate occasions, the formation was the target of an interception run by a fighter aircraft. In each situation, the fighter aircraft passed by the formation in relatively close proximity at high airspeeds. While the refresh rate of the TCAS screen was inadequate to continuously display the fighter traffic, at no time were any problems found with the wingman's ability to identify and track the lead aircraft.

The formation was flown within the Los Angeles Class B airspace at 16,000 feet PA to evaluate the effects of a high density traffic environment on TCAS station-keeping utility. The formation was flown across the top of Los Angeles International Airport between 0745 and 0830 hours local time. A composite radar track of the entire flight was recorded by Ridley Mission Control in cooperation with Los Angeles Center air traffic control (ATC) facility. Figure A-6 gives a depiction showing the highest level of traffic density encountered during this test point. The traffic density reached up to 16 aircraft inside of a 30 nautical mile radius at certain times during the flight. A traffic density of greater than 30 aircraft inside of a 30 nautical mile radius of the formation was desired because the Collins TCAS was designed to track no more than 30 aircraft (Reference 1). Although the desired traffic density was not seen during testing, the traffic density experienced was as high or higher than the T-1A aircraft were expected to encounter during training operations; therefore, the flight was considered successful, and test objectives for this area were met.

### **Displays, warning cues:**

Using the TCAS display, the pilot's ability to accurately maintain normal cell position was satisfactory. The display size was adequate with good resolution of symbols and characters. Display location was adequate, given that the single display was shared by both pilots. The display lighting was adequate during the daylight evaluation. Display location prevented the sunlight from washing out the lighting under most flight conditions. Color coding of the traffic was useful in prioritizing traffic scan but was not used extensively for station-keeping. Traffic information content was generally adequate, with bearing information and altitude separation the most useful. The God's eye view was very user friendly and greatly contributed to increased pilot situational awareness.

Traffic information format was arranged logically, with vital information clearly and concisely presented. Altitude differential was placed appropriately above or below the target symbol to indicate qualitatively the target's position, and the actual altitude separation was presented digitally on the display in hundreds of feet. This feature allowed for a quick scan to determine relative aircraft position. The concentric range distance scale was very useful while monitoring formation aircraft relative range. An OFF SCALE warning provided cues even if an aircraft's relative range was beyond the selected scale. The range scale could be changed quickly to a 40

nautical mile scale with a single push-button actuation for a quick look at the overall traffic environment.

System failure indications were generally lacking with only a TCAS FAIL warning displayed if power was removed from the transponder. No indications were provided in the event of system anomalies or dropouts within the cell formation. When system failures were simulated, the TCAS coast mode continued to present target information for 6 seconds before the target symbol disappeared from the screen with no warning or caution indications. Improved TCAS system degradation and failure indications would be desired to provide the pilots with increased confidence and situation awareness during cell formation station-keeping. **Implement a caution/warning indication of lead/wingman signal loss or TCAS malfunction. (R5)**

Traffic warning information was adequate, with the color coding and aural warnings particularly useful. The aural indication of "Traffic, Traffic" was a good method of keeping lead aware of unexpected closure or position changes in the cell formation, but it could be distracting when communicating with ATC or inter-cockpit. A capability similar to deselecting a voice radio guard channel would be useful to reduce the potential of crew distraction and decreased situation awareness. **Incorporate a selective muting capability to the TCAS aural warning system. (R8)**

No relative range or altitude rate information was provided by the TCAS to the pilot. The A/A TACAN was useful as a cross check for range rate, with closure rates presented in knots. The closure information was useful in station-keeping duties and decreased pilot workload, although A/A TACAN range and range rate accuracies were not specifically evaluated. **AETC IMC cell formation procedures should use A/A TACAN as a cross-check tool during station-keeping. (R6)** Accurate relative range rate and altitude rate information provided by TCAS would be very useful to the pilot while prioritizing specific aircraft for potential evasive action or directing formation position changes to avoid high threat traffic. **Add the capability to selectively display position rates between lead and wingman on the TCAS MFD. (R7)** Another useful enhancement would be the capability to positively distinguish between cell formation aircraft and other TCAS-equipped aircraft, either through color coding or different symbology. **Implement the capability to independently distinguish lead or wingman, possibly by using color coding or unique symbology. (R4)**

System response time and symbol movement rate was satisfactory to track traffic. Lead or wingman could distinguish discrete relative movements, which proved especially useful for unannounced turn recognition. The display refresh rate was satisfactory for station-keeping but marginal for extremely high closure rates (over 200 knots). Numerous interceptions of the T-1As in the R-2508 complex by rapidly closing fighter aircraft were observed, and the TCAS refresh rate was marginal to track the fighters. These closure rates did not affect TCAS performance, degrade presentation of the cell formation aircraft, or impact the utility of using TCAS for station-keeping.

Specific mission scenarios were flown using operationally representative maneuvers, and the pilot in the wingman aircraft flew with an "IFR hood" obstructing his vision of outside references. This test procedure was intended to simulate IMC flight. The display cues were appropriate for takeoff in IMC. The lead aircraft appeared on the TCAS screen an average of five seconds after takeoff (range was from 2.4 - 6.0 seconds). The 20-second spacing used on takeoff worked well for helping the wingman attain a one-nautical mile spacing immediately upon takeoff.

The ability to maintain normal in-trail position accurately using the 2 nautical mile range scale on the T-1A TCAS in a high density traffic environment was satisfactory. The display gave appropriate cues and warnings to the wing pilot which enabled him to maintain an appropriate formation position throughout the flight. There were no dropouts or anomalies observed on the TCAS screen during the entire flight on either the lead or wing aircraft. With the two nautical mile range scale set on the screen, there were no problems with the pilot in the wing aircraft keeping positive identification of the lead aircraft at all times. The 2 nautical mile range screen display algorithm incorporated an altitude filter which displayed only targets within 2,700 feet relative altitude with the host aircraft; so even in the presence of relatively high density traffic, maintaining track of the lead aircraft's position was easy.

The lead aircraft operated on a 40 nautical mile range scale while in the high density traffic environment, enabling the lead pilot to maintain situational awareness of the traffic in the area around the formation. This procedure worked well. The lead aircraft was able to monitor large movements of the wingman and keep track of any potential traffic conflicts for the formation at the same time. If a more precise view of the wingman's position was needed, two pushes of the up arrow button changed the display to the 2 nautical mile range screen, and back to the 40 nautical mile range.

#### **Workload assessment:**

The results of the pilot surveys shown in Table 2 indicated satisfactory workload requirements. Workload evaluations were categorized according to flight phase and flight conditions such as VMC, simulated IMC, and actual IMC. Workload was light during all VMC and simulated IMC testing, as well as for actual IMC straight and level station-keeping. Workload was moderate during climb and descent, and high during maneuvering, especially for unannounced turns.

Pilot workload was dependent not only on weather conditions but also on crew coordination and communications. Pilot comments indicated workload decreased when the nonflying pilot assisted the flying crewmember with radio communications, navigation, and configuration changes (speed brakes during descents). The flying crewmember could devote more time to maintaining proper position and scanning the TCAS for position changes or lead maneuvers.

Positive two-way communications between aircraft greatly reduced pilot workload. When lead announced a maneuver, the wingman was able to anticipate the maneuver and react quickly to movement on the TCAS display. The higher SWAT ratings reflected the trend of increased pilot workload during unannounced maneuvering, as experienced during the high density traffic test point. This problem was magnified in simulated and actual IMC when the pilot found that an effective instrument scan was difficult while reacting to symbol movement on the TCAS display. **AETC IMC cell formation procedures should include the requirement to confirm operational inter-aircraft communications prior to entering IMC. (R3)**

There were 29 SWAT ratings gathered during this test. The SWAT ratings ranged from zero (meaning virtually no impact on workload) to 59.8 (generally regarded as high workload). The SWAT ratings, corresponding values and task averages are presented in Table 2. In the case of the in-trail descents, the SWAT average went down due to a smaller sample size and an increase in pilot proficiency.

Table 2 HAVE CELL SWAT Ratings

MANEUVER	SWAT AVERAGE*	# OF DATA POINTS	RANGE
VMC	9.05	2	0-18.1
SIM IMC T/O	40.37	4	28.8-50.3
1000 FT/MIN CLIMB	28.8	1	(None)
<u>MCT-5% CLIMB</u>			
--SIM IMC	40.23	3	28.8-59.8
TURN RECOGNITION	0	1	(None)
<u>TIMED TURNS</u>			
--VMC	21.5	2	21.5 (All)
--SIM IMC (Unannounced)	81.0	1	(None)
-- SIM IMC (Announced)	0	1	(None)
--ACTUAL IMC (Announced)	50.3	1	(None)
TCAS INTERFERENCE	21.5	1	(None)
<u>IN-TRAIL DESCENTS</u>			
--SIM IMC	39.55	2	28.8-50.3
--ACTUAL IMC	32.1	1	(None)
<u>STRAIGHT &amp; LEVEL</u>			
ACTUAL IMC	21.5	1	(None)

\*Average is valid if the maneuver conditions, aircraft and flight conditions were very close to identical for the two test pilots.

This page intentionally left blank.

## CONCLUSIONS AND RECOMMENDATIONS

Overall, the Traffic Alert/Collision Avoidance System (TCAS) was satisfactory for use during limited instrument meteorological conditions (IMC) cell formation procedures in the T-1A Jayhawk.

System performance characteristics during cell formation procedures were satisfactory. TCAS position accuracy was adequate, with test results indicating one standard deviation errors of 80 feet relative altitude, six degrees relative bearing, and 240 feet relative range. Contractor-predicted error analyses should be examined to verify TCAS position accuracy test data. There were no antenna blanking or degradation problems which would impact normal cell station-keeping operations. A safe operational envelope was determined as 0.5-1.5 nautical miles aft and 60 degree aspect when wingman was co-altitude to 1,000 feet above lead; 0.8 to 1.5 nautical miles aft and 60 degree aspect when wingman was co-altitude to 1,000 feet below lead.

The TCAS operation in a high density traffic environment and prioritization characteristics were satisfactory. A two-ship cell formation was flown through the Los Angeles basin with traffic densities reaching up to 16 aircraft within a 30 nautical mile range. There were no problems maintaining positive identification of lead on the TCAS screen and maintaining desired cell formation. High-speed intercepts flown by fighter aircraft toward the flight formation caused no problems with dropouts or with maintaining lead identification.

Finally, workload during simulated and actual IMC ranged from light (straight and level flight) to high (unannounced maneuvering), and was satisfactory for using TCAS to maintain cell formation during IMC procedures. Overall, the TCAS was satisfactory for use in transiting through IMC. The TCAS was not evaluated for use during extended IMC operations; therefore, the following recommendation applies to the use of TCAS to penetrate and pass through IMC only.

**1. Incorporate the use of TCAS into current AETC cell procedures for limited IMC operations, pending results of a statistical error analysis of a larger sample size of TCAS units. (page 13)**

No evaluation of operational maneuvers was accomplished due to the lack of established procedures for station-keeping using the TCAS. The current AETC cell formation procedures were used whenever feasible during the course of testing. A set of established procedures are required for operational use of this system in actual IMC, with specific emphasis on lost wingman procedures.

**2. Establish and verify procedures, to include positive altitude separation, for T-1A cell formation using the TCAS in IMC. (page 13)**

In general, workload associated with using TCAS for station-keeping during IMC cell formation procedures was satisfactory. Workload was light during straight and level cell formation flight, for both visual meteorological conditions (VMC) and IMC. However, during the Los Angeles basin high density test point, inter-aircraft communication was severely limited due to the excessive radio traffic, so all maneuvering was performed unannounced. Maneuvering without prior notification raised workload levels to moderate and high. Inter-aircraft communication should be considered a requirement for using TCAS for cell formation station-keeping during IMC.

**3. AETC IMC cell formation procedures should include the requirement to confirm operational inter-aircraft communications prior to entering IMC. (page 18)**

Other recommendations were made which would improve the performance and human factors integration of the TCAS system. The recommendation number indicates the priority of the recommendation in the view of the test team. Recommendations 1-3 are the most important and should be implemented together. The rest of the recommendations are areas of improvement which, while not necessary for safe operation of the system, would enhance system utility and pilot performance.

The TCAS system was not evaluated in moderate precipitation or icing conditions. If use in adverse weather is required, system performance characteristics should be determined prior to operating in such conditions. System utility for formation station-keeping in adverse weather should be evaluated to ensure no degradations exist which would impact normal cell formation procedures.

**4. Evaluate system performance in adverse weather, to include moderate precipitation and/or icing, if operation in such conditions is required. (page 13)**

The TCAS displays, warnings, and cues were satisfactory. The display symbology and screen layout were logical and useful for station-keeping. A useful enhancement would be the capability to positively distinguish between cell formation aircraft and other transponder-equipped aircraft, either through color coding or different symbology.

**5. Implement the capability to independently distinguish lead or wingman, possibly by using color coding or unique symbology. (page 17)**

The TCAS provided no system failure indications in the event of TCAS anomalies or formation aircraft dropout. Such information would be useful to the pilot for increased confidence in using the TCAS for station keeping procedures.

**6. Implement a caution/warning indication of lead/wingman signal loss or TCAS malfunction. (page 17)**

In the absence of position rate information on the TCAS multifunction display (MFD), air-to-air (A/A) TACAN was useful to cross-check relative rate and should be incorporated into AETC procedures for IMC cell formation.

**7. AETC IMC cell formation procedures should use A/A TACAN as a cross-check tool during station-keeping. (page 17)**

TCAS lacked the ability to display range rate and altitude rate between formation aircraft. Position rate information would be a useful enhancement to aid the pilot during station-keeping procedures.

**8. Add the capability to selectively display position rates between lead and wingman on the TCAS MFD. (page 17)**

Aural warning tones were helpful, but during extended periods of operation in high density traffic, the option of muting aural warnings was not provided with the current system. This option would be desired to reduce the potential of crew distraction and improve the training effectiveness during station-keeping procedures.

**9. Incorporate a selective muting capability to the TCAS aural warning system. (page 17)**

## REFERENCES

1. Flight Manual USAF Series Aircraft T-1A, Technical Order 1T-1A-1, Secretary of the Air Force, Change 1, 30 June 1993.
2. Introduction to TCAS II, United States Department of Transportation, Federal Aviation Administration, March 1990.
3. Reid, G.B. and Nygren, T.E., The Subjective Workload Assessment Technique: A Scaling Procedure for Measuring Mental Workload, in P. Hancock and N. Meshkati (eds.), Human Mental Workload (Amsterdam, The Netherlands, Elsevier, 1987).
4. GPS100 PC Software Kit Owner's Manual, GARMIN, 1992.
5. MATLAB Statistics Toolbox User's Guide, The MathWorks, Inc., January 1994.
6. Microsoft Excel Version 5.0 Users Guide, Microsoft Corporation, 1994.

This page intentionally left blank.

**APPENDIX A  
TCAS ACCURACIES  
AND  
HIGH DENSITY TRAFFIC DEPICTION**

This page intentionally left blank.

Table A1 Measured TCAS Error

Test Point	Wing 500 Feet Above Lead		Wing 1000 Feet Above Lead		Wing 1000 feet Below Lead	
	Range Error (feet)	Bearing Error (degrees)	Range Error (feet)	Bearing Error (degrees)	Range Error (feet)	Bearing Error (degrees)
1	-350	-4.5	-290	-5	-680	-7
2	-0	0	100	-14	-160	8.5
3	-200	-5	240	-3.5	-270	6
4	20	-3.5	350	-1	20	8.5
5	-30	3.5	10	8	80	3
6	-550	-5	-30	-1	-120	6.5
7	-420	0	-480	-3.5	-580	-1.5
8	*	*	-160	2	-270	-9.5
9	*	*	-630	2.5	-450	-4.5
10	-280	-3.5	-200	0	90	-2
11	-440	-2.5	-140	3.5	-200	-1.5
12	90	2	170	5.5	-80	-3
13	-220	-1	-10	7	-100	-8.5
14	170	1.5	-330	-2.5	*	*
15	-440	-1	-170	-2	-500	3.0
16	-190	-1	-430	-6	-70	-1.5
17	-110	-4	50	-12	90	20

Test Point Definition

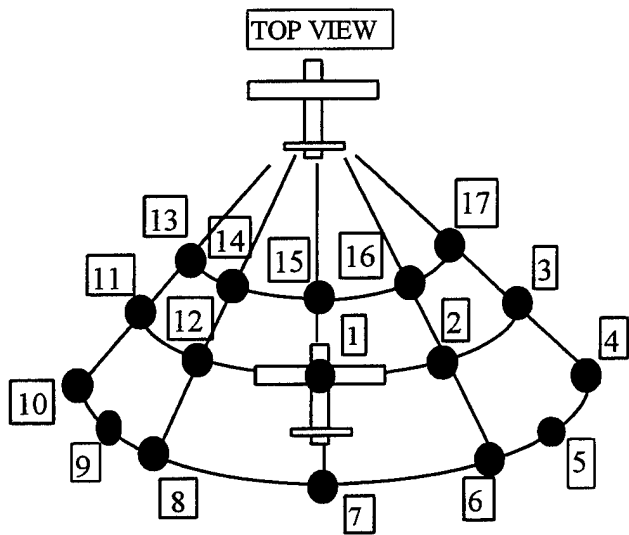

SIDE VIEW

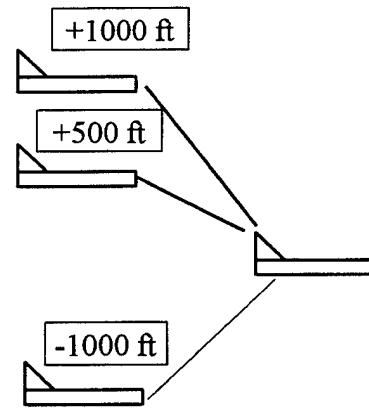

Note: Test Point Numbering Sequence is Repeated For Each Altitude

\*Test Data Unusable

Data Basis: Flight Test  
 Date: 29 Mar 95  
 Position Reference: Ridley FPS-16 Radar (Skin Track)  
 GPS: Garmin GPS100  
 Aircraft: Two T-1As, Tail Number 404, 633  
 MSL Altitude: 20,000 Ft PA  
 Velocity: 250 KCAS

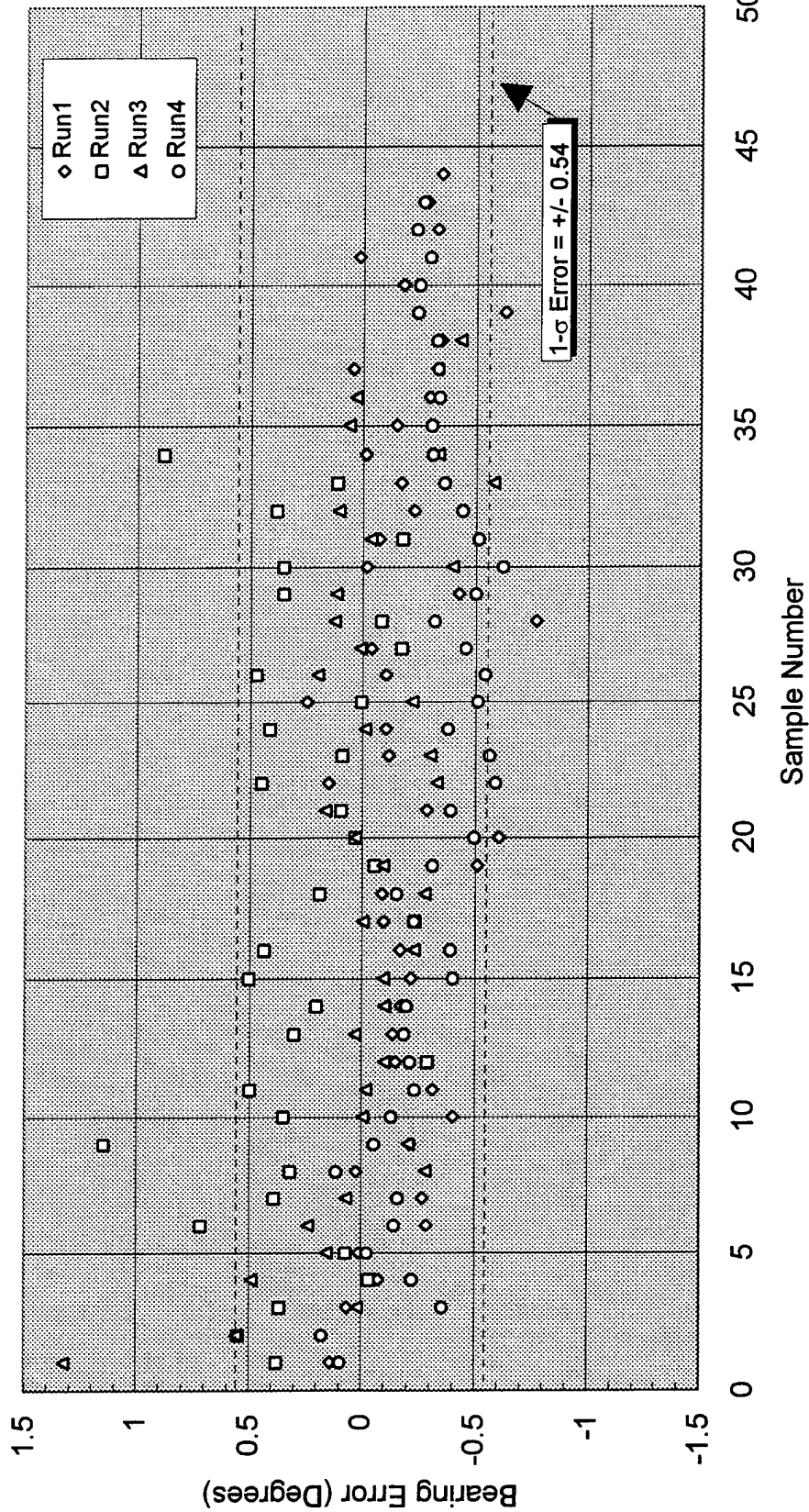

Figure A1 GPS Bearing Error

Data Basis: Flight Test  
 Date: 29 Mar 95  
 Position Reference: Ridley FPS-16 Radar (Skin Track)  
 GPS: Garmin GPS100  
 Aircraft: Two T-1As, Tail Number 404, 633  
 MSL Altitude: 20,000 Ft PA  
 Velocity: 250 KCAS

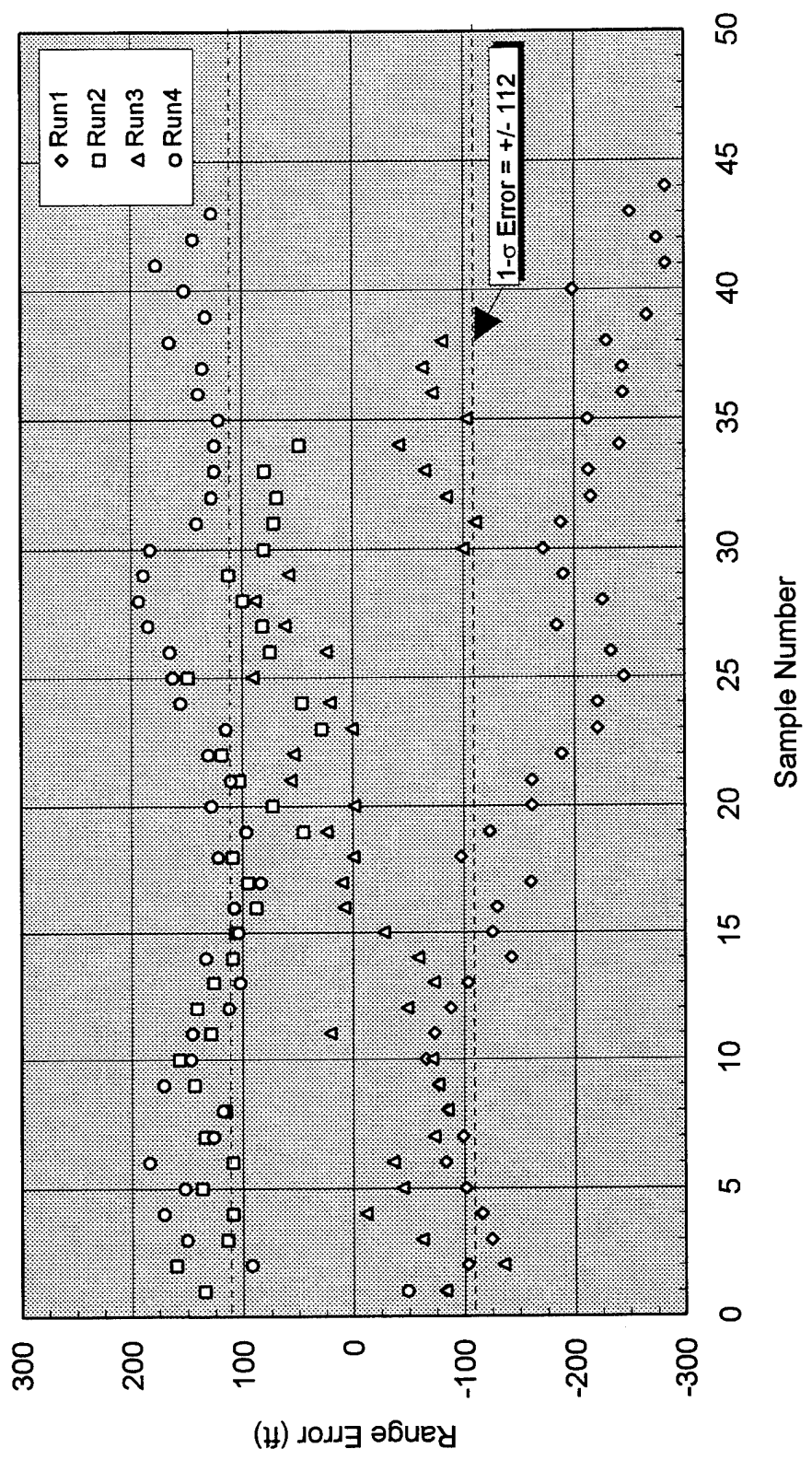

Figure A2 GPS Range Error

Data Basis: Flight Test  
 Dates: 3, 4 Apr 95  
 Altitude: 20,000 ± 1000 Ft PA  
 Velocity: 250 KCAS  
 Position Reference: Garmin 100 GPS  
 Aircraft: Two T-1As, Tail Number 404, 633

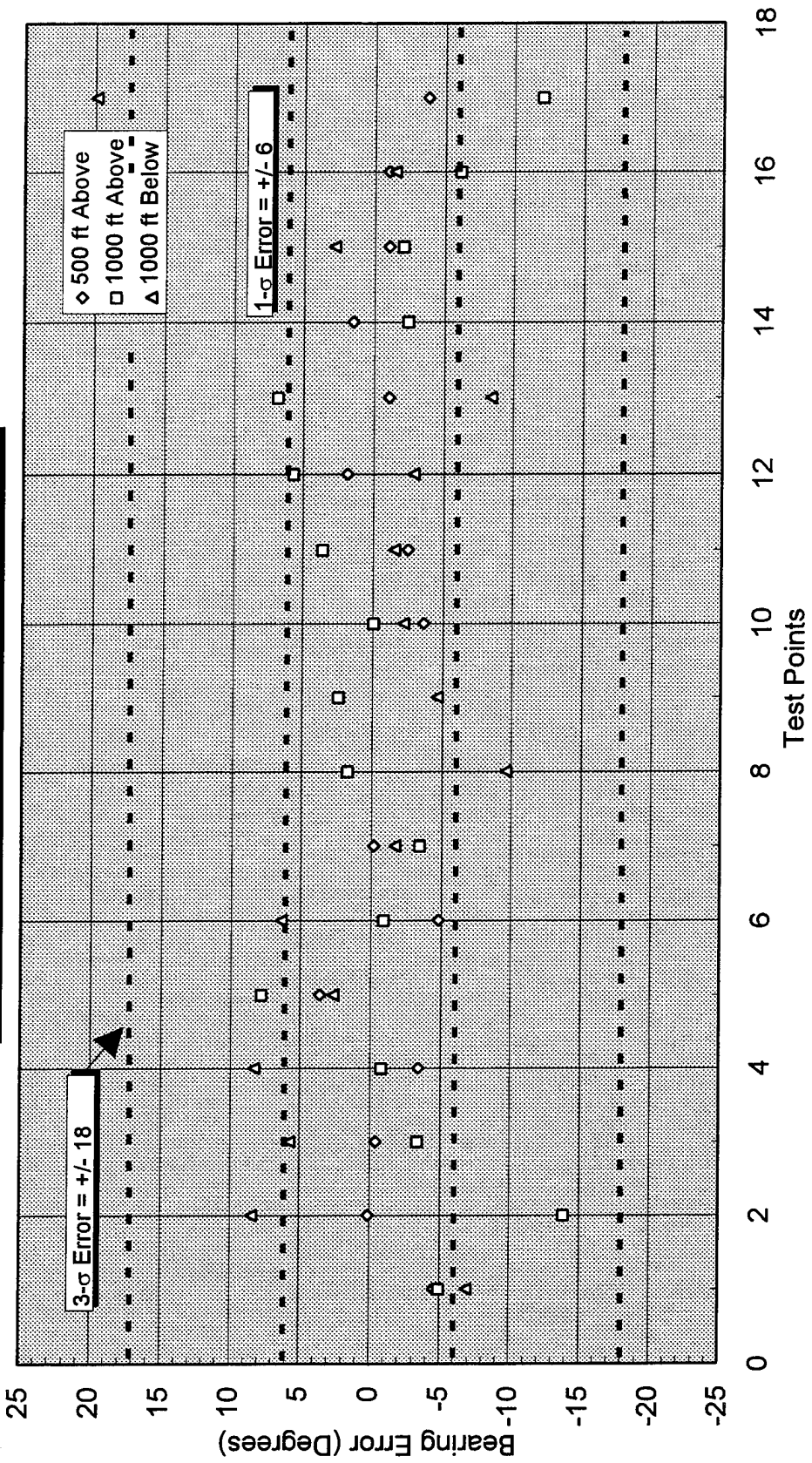

Figure A3 TCAS Bearing Accuracy

Data Basis: Flight Test  
 Dates: 3, 4 Apr 95  
 Altitude: 20,000 ± 1000 Ft PA  
 Velocity: 250 KCAS  
 Position Reference: Garmin 100 GPS  
 Aircraft: Two T-1As, Tail Number 404, 633

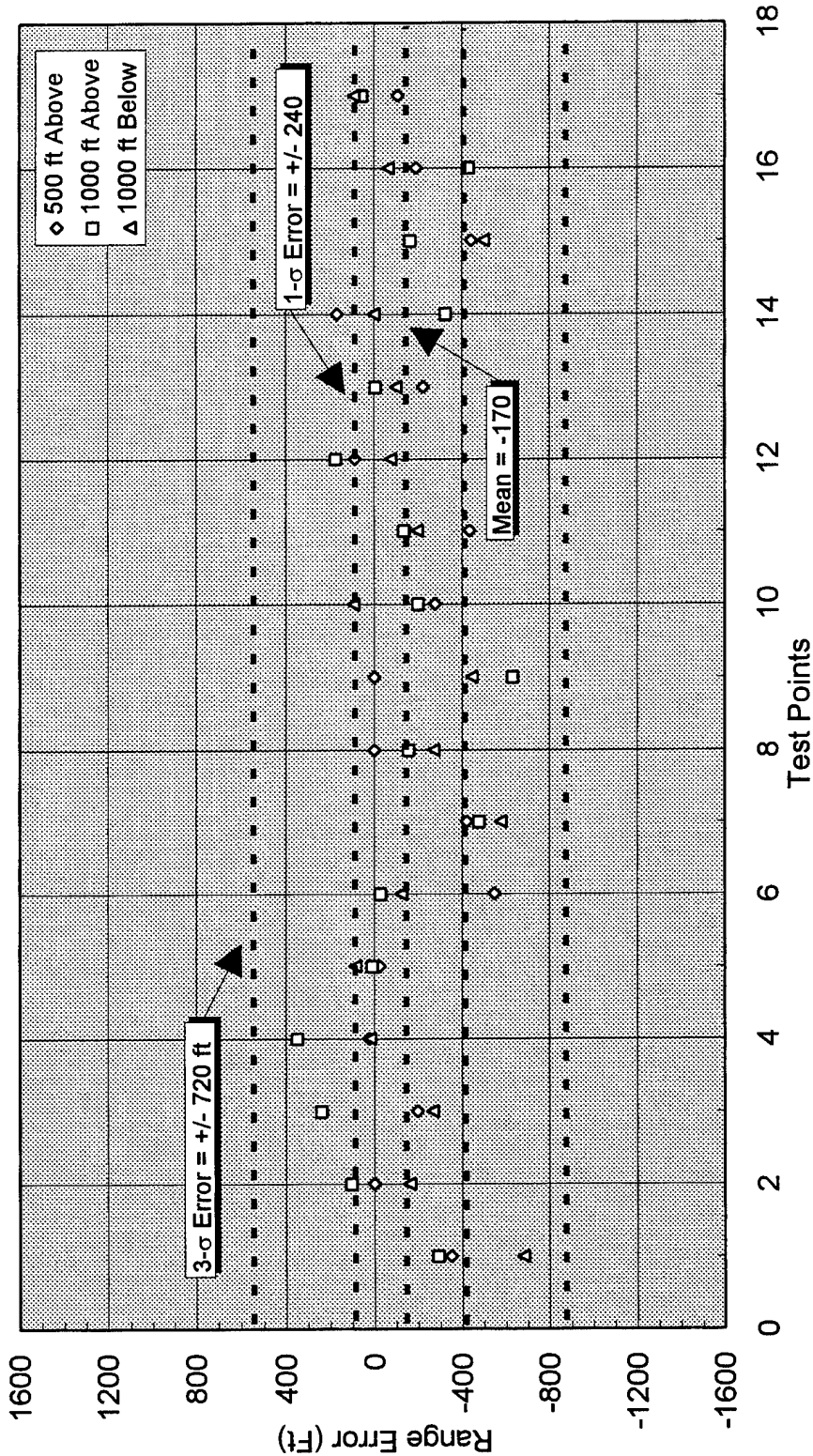

Figure A4 TCAS Range Accuracy

Data Basis: Flight Test  
 Dates: 3,4 Apr 95  
 Altitude: 20,000 ± 1000 Ft PA  
 Velocity: 250 KCAS  
 Position Reference: Barometric Altimeter (29.92 Set)  
 Aircraft: Two T-1As, Tail Number 404, 633

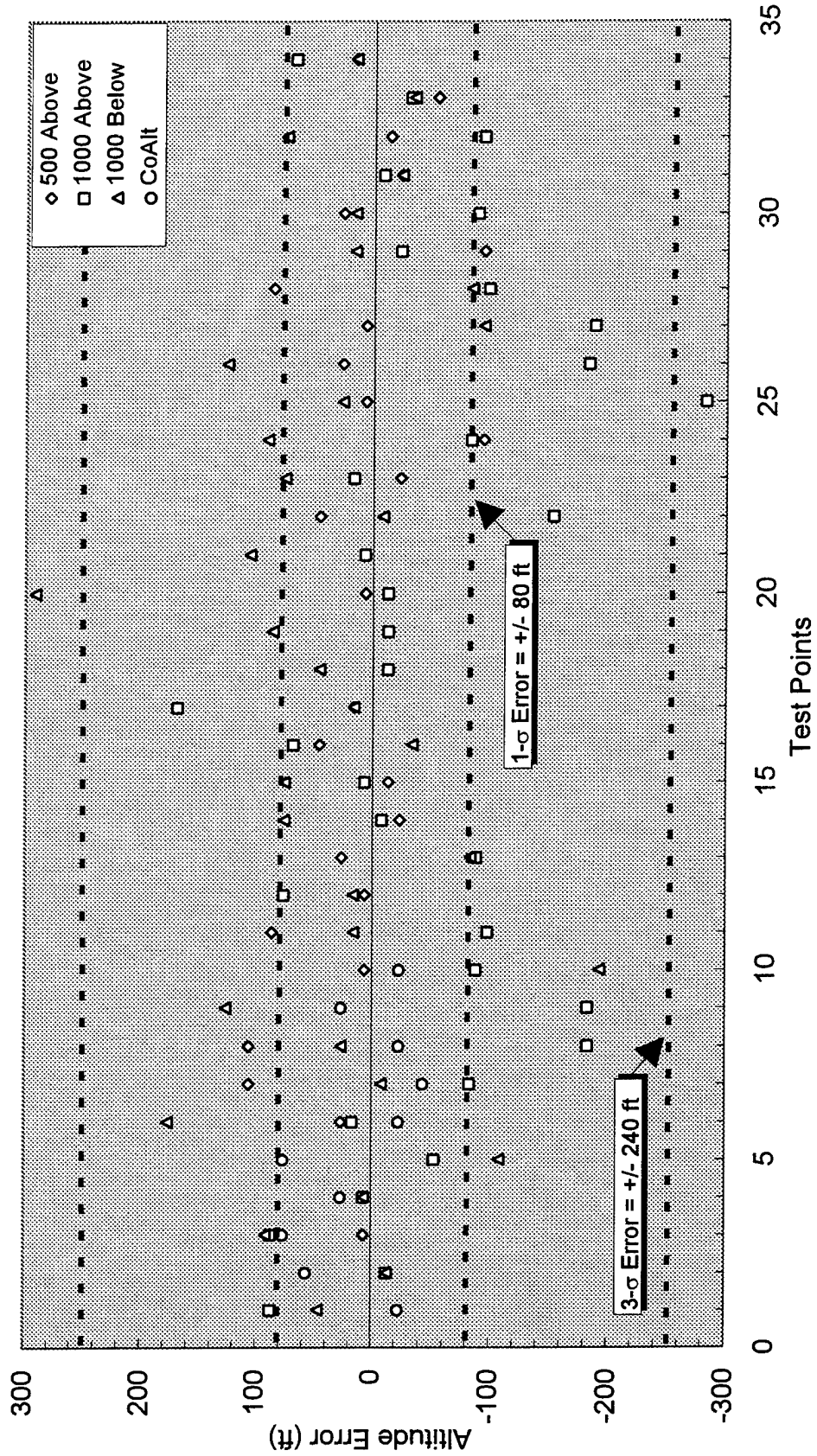

Figure A5 TCAS Altitude Accuracy

Data Basis: Flight Test  
 Flight Date: 7 April 95  
 Altitude: 16,000 ft PA  
 Location: Los Angeles Basin  
 Traffic Density: 16 Aircraft Per 30 nm Radius  
 Local Time: 7:58AM Local (14:58 Zulu)  
 Test Point: High Density Traffic Analysis  
 Source: Ridley Technical Evaluation Commands and Control System

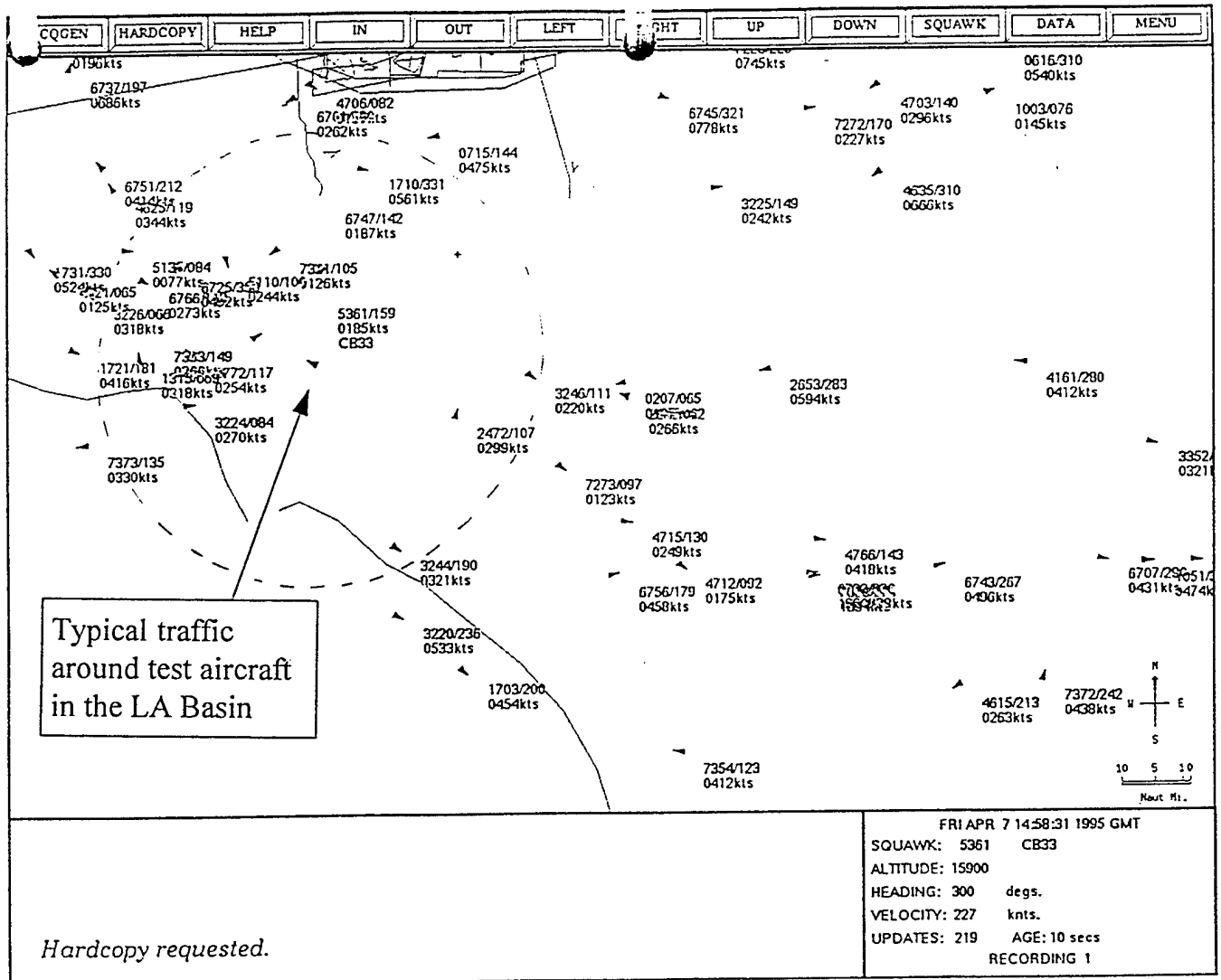

Figure A6 TCAS High Density Traffic TECCS Depiction

This page intentionally left blank .

**APPENDIX B**  
**DATA REDUCTION AND ANALYSIS**

This page intentionally left blank.

## TCAS Position Accuracy Data Analysis

Position accuracy was evaluated by comparing the TCAS display to GPS position data. Seventeen different stable points defining a cone of operation behind the lead aircraft were defined (see Figure 2). A total of 51 stable points distributed throughout the proposed cone of operation were evaluated. The aircraft were stabilized in these positions for 15 seconds each. During this period, the TCAS display was video-taped in each aircraft. Also a data stream produced by the Garmin 100 GPS units was recorded on laptop computers in each aircraft, using the Garmin PC100 software (Reference 4). The 0.5 Hertz data stream consisted of a time stamp, latitude, and longitude. The aircraft headings and barometric altimeter readings were recorded from aircraft instruments for each aircraft during the stable points.

Still photographs were produced from a digitized copy of the video tape of the trailing aircraft's TCAS display for each stable point. An example photograph of test point 9 at 1000 feet above lead is shown in Figure B-1. A relative bearing and range representing the wing aircraft's position behind the lead aircraft was obtained graphically from each of these photographs, using dividers and an engineering scale.

The ASCII files collected on the computers from each aircraft were then dissected into individual files representing each stable point. For example, an ASCII file containing test point 9's position data was extracted from the wing aircraft's data file and another file containing the lead aircraft position data for the same test point was extracted also. This was done for each stable point at each altitude.

Computer software was used to read in the individual stable point data files from lead and wing, time correlate the points, and produce a true bearing and range for each point. This software reduced two data files (one from lead and one from wingman), each corresponding to an individual stable point, and created a third file that consisted of a time stamp, the true bearing, and the range for each data element contained in the original file (Note: a 1 sample/2 second data rate with stable points of 15 seconds each yielded approximately 9 data elements per stable point). The software ensured that the time stamps of the individual files were identical so that mismatches in sample times did not occur. The program was written by the test team in BASIC programming language, and a listing of the software source code is provided within this appendix.

The individual files containing the bearing and range data of each stable point were imported into a Microsoft Excel Version 5.0a spreadsheet (Reference 6). The individual bearings were averaged to produce a single value representing the true bearing of the lead aircraft relative to the wing aircraft. Likewise, the individual range samples were averaged to produce a single value representing the range between the two aircraft.

The true heading value was converted to a relative bearing. This was done by using the magnetic headings recorded by hand on the wing aircraft during the stable points, and the magnetic correction for the Edwards Air Force Base Area (i.e. 14 degrees). For example, Point 9 yielded an average true heading of 235.65 degrees. The magnetic heading of the wing aircraft was 175 degrees. The bearing from wing to lead was determined from the stable point photograph to be 43 degrees right. Adding these and the magnetic correction yielded a true heading of 232 degrees. Subtracting this value from that computed from the GPS data yielded an aspect error on the TCAS display of -3.7 degrees. The range error was much easier to compute. The range obtained from the photograph was subtracted from the average range value of the GPS data to yield the range error.

The altitude error was obtained simply by comparing the displayed TCAS altitude (+1200 in Figure B-1, indicating the lead aircraft was 1200 feet above the wing) to the difference in the barometric altimeters (29.92 set in each aircraft). The aircraft altimeter readings and the TCAS displayed altitude were recorded in each aircraft during each stable point. The difference between the barometric altimeters was used as reference and subtracted from the reading on the wing aircraft's TCAS display. It should be noted that the TCAS only displayed altitude readings to hundreds of feet.

Table B1 TCAS Example Accuracy Calculation\*

Card E-5	Test Point 9	1.5 nm Aft	45 Deg Right		
GPS	Bearing	Range	Time		
	235.1602	9253.23	18:04:10		
	235.3605	9171.724	18:04:12		
	235.391	9050.429	18:04:14		
	235.6921	8861.284	18:04:16	←Photo Taken Here	
	235.6881	8731.013	18:04:18		
	235.8452	8593.114	18:04:20		
	236.0614	8452.606	18:04:22		
GPS Average	235.6531	8806.497			
TCAS	Photo	Magnetic	Magnetic Area	Photo	Photo
	Bearing	HSI Heading	Correction	True Bearing	Range
	43	175	14	232	8460
Error	Bearing	Range			
	-3.65309	-346.467			

\*Test Point 9: Wing 1.5 nm Aft and 45 Degrees Right of Lead

An analysis to determine the validity of assuming a normal distribution was performed on the range and bearing errors, using the MATLAB "normplot" function. The function output produced straight line plots, indicating the assumption of normality was good (Reference 5). Suitability plots for bearing and range errors are shown in Figures B-2 and B-3, respectively. These plots show that the TCAS range and bearings errors observed by the test team were normally distributed.

Data Basis: Flight Test  
Lead Altitude: 20,000 ft PA  
Photo: Wing Aircraft TCAS Display  
Flight Date: 4 April 95  
Wing Altitude: 18,000 ft PA  
Test Point: Wing 1.5 nm Behind Lead, Lead 45° Right of Wing (Test Point 9)

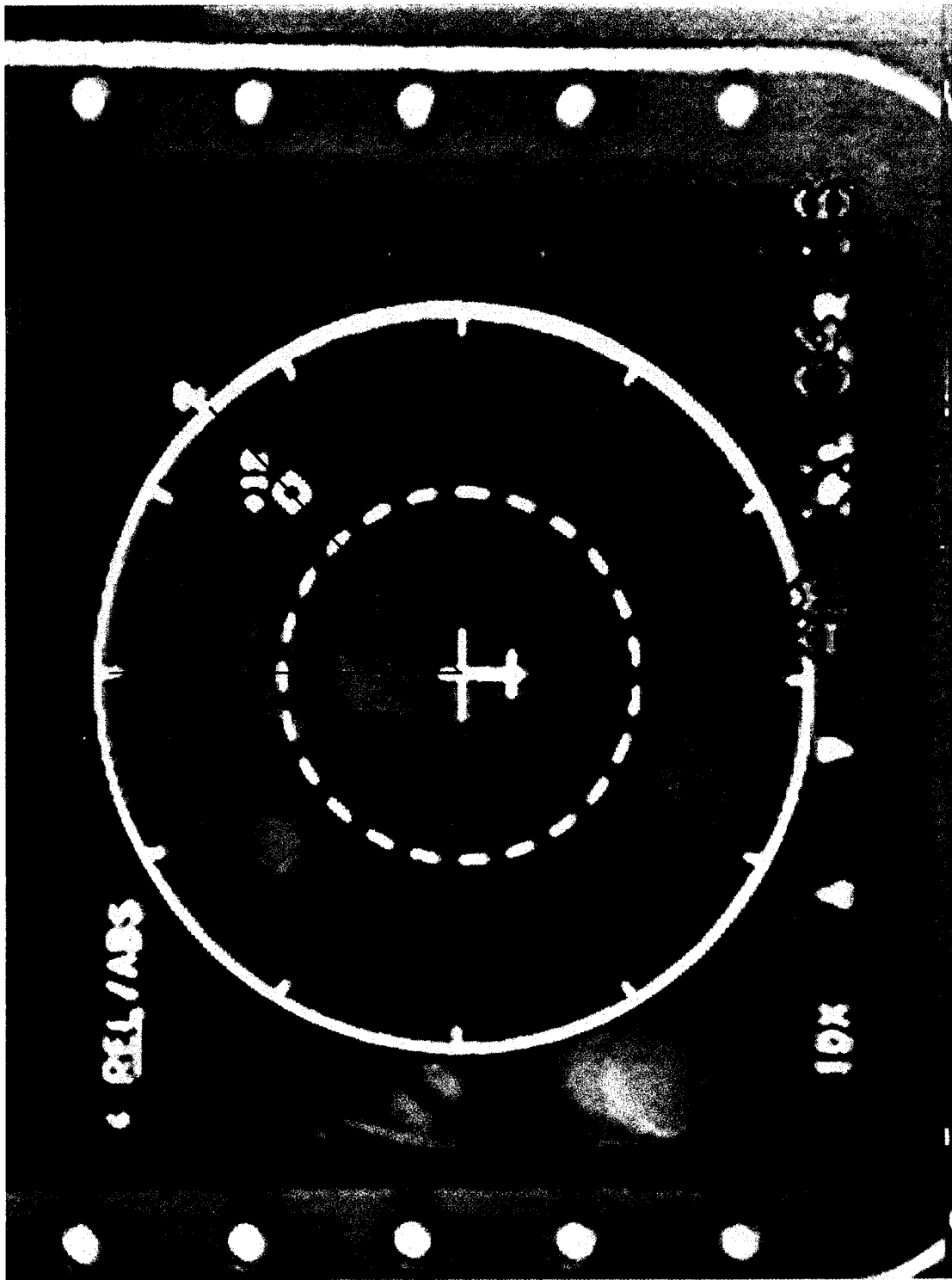

Figure B 1 Example TCAS Accuracy Photograph

Data Basis: Flight Test  
Dates: 3,4 Apr 95  
Altitude: 20,000 ± 1000 Ft PA  
Velocity: 250 KCAS  
Position Reference: Garmin 100 GPS  
Aircraft: Two T-1As, Tail Number 404, 633

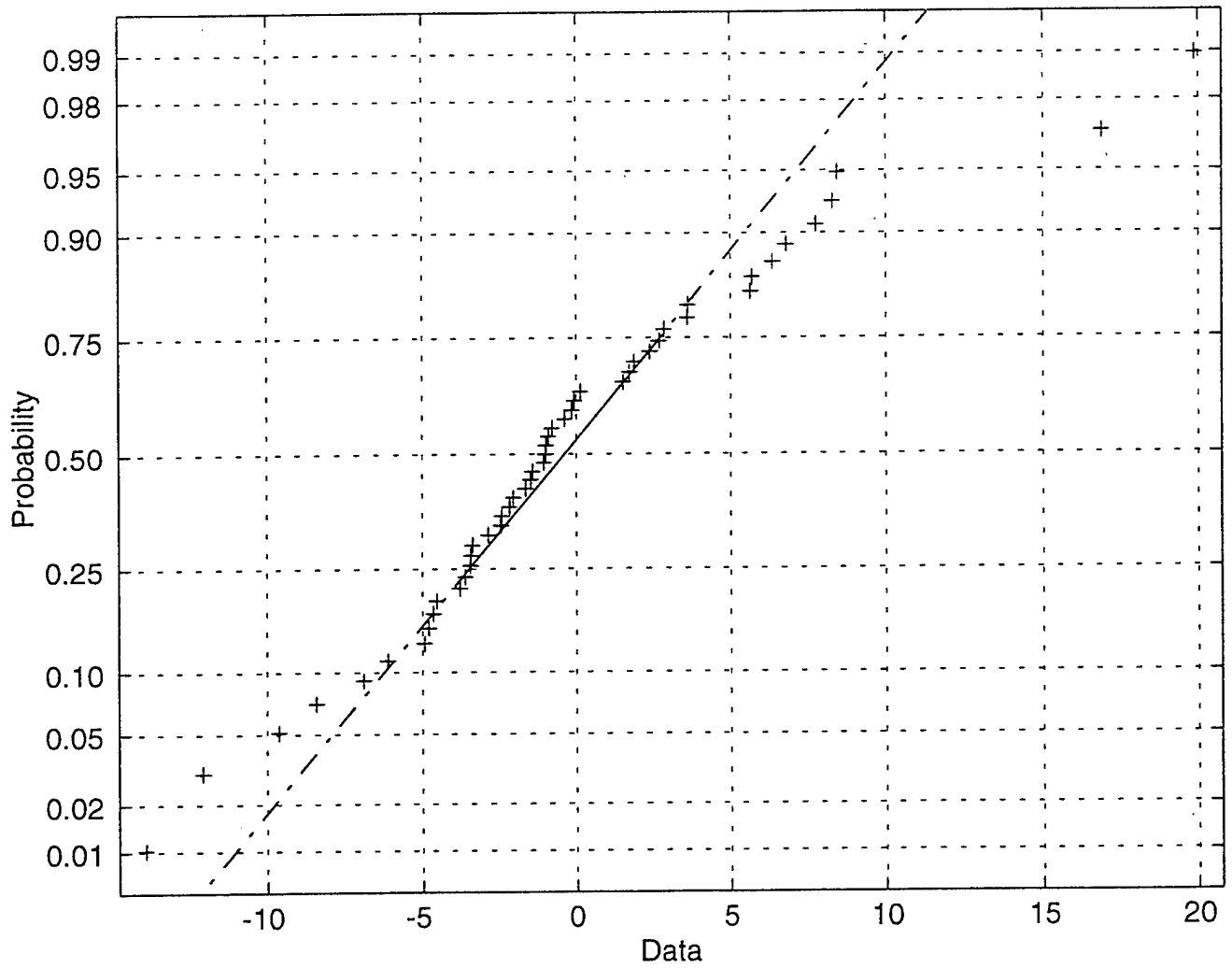

Figure B2 TCAS Bearing Error Distribution

Data Basis: Flight Test  
Dates: 3,4 Apr 95  
Altitude: 20,000 ± 1000 Ft PA  
Velocity: 250 KCAS  
Position Reference: Garmin 100 GPS  
Aircraft: Two T-1As, Tail Number 404, 633

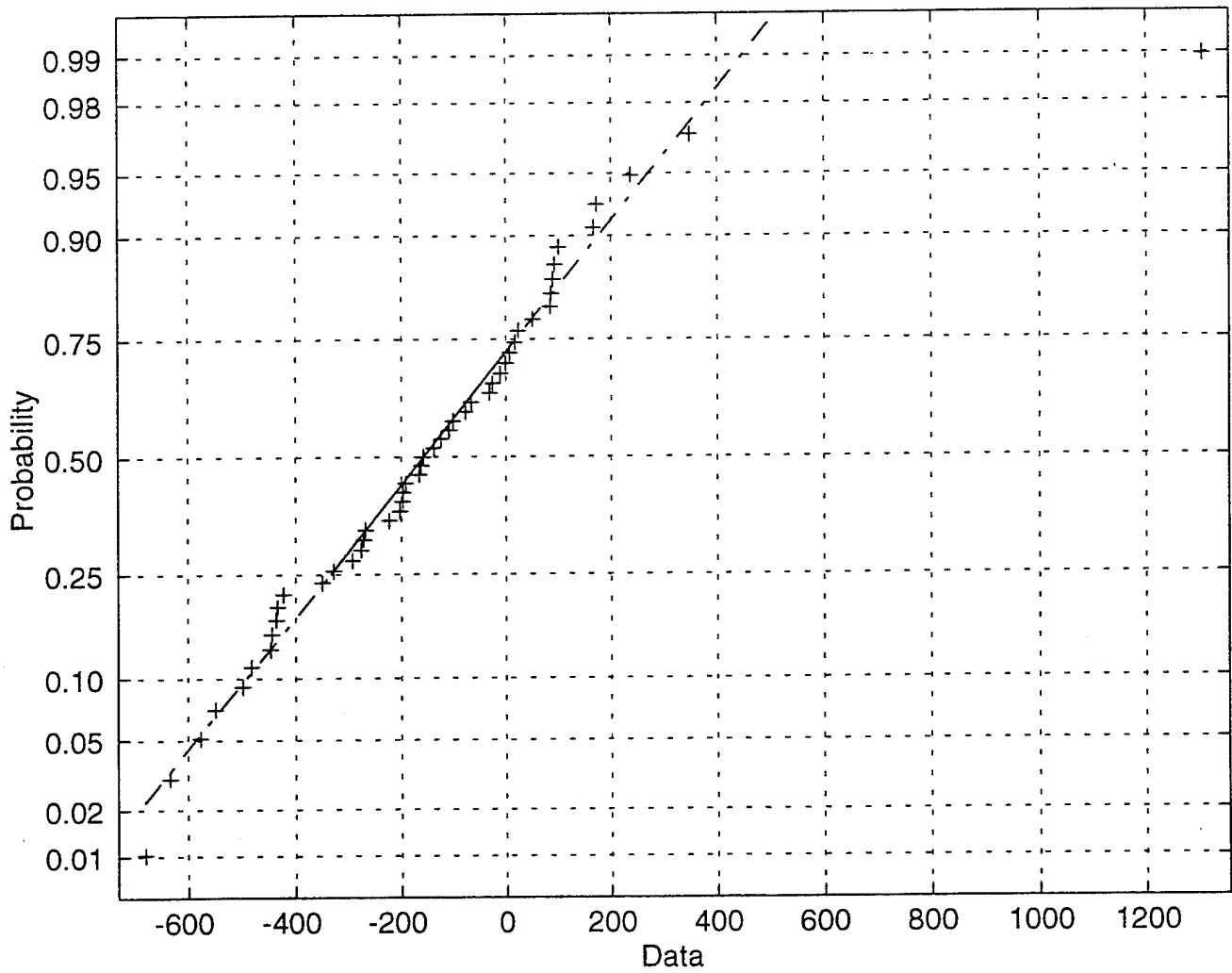

Figure B3 TCAS Range Error Distribution

## Relative Bearing and Range Calculation (BASIC)

```

2 '  ** PROGRAM DESCRIPTION*** LINES 0-99
4 '  PROGRAM TITLE: offset.bas
6 '  PROGRAM AUTHOR: James D. Kunzman / Frank V. Cranor
7 '  Modified by: David J. Morgan (30 Mar 1995)
8 '    VER$ = "3.0": ' (VERSION)
10 '    DATE: May 27, 1985 (1120L)
12 '    PURPOSE: This program will convert from LAT-LON and LAT-LON to
14 '              bearing/range. It computes true heading
16 '              and range in feet.
18 '
20 ' VARIABLES USED                PURPOSE
22 ' -----
26 'STRING:  FLAG$                Dummy string variable
32 '
34 'DOUBLE:  BEARING              Bearing
36 '    DDD                Decimal degrees for format conversion
38 '    DME                Distance in nautical miles
40 '    DMS                Degree/Minute/Second format for conversions
42 '    FLAG                Dummy variable
44 '    LATD                Latitude of Destination (now lead)
46 '    LATS                Latitude of Source or Start (now wing)
48 '    LNGD                Longitude of Destination
50 '    LNGS                Longitude of Source or Start
52 '    MIDLAT              Middle Latitude of LATS-LATD
54 '    NM                  Constant for Nautical Mile - 6076.12'
56 '    PI                  PI to 15 digits precision
58 '    R                    Conversion factor from degrees to radians
60 '    RANGE                Working variable for range
62 '
64 '    TM                  Temporary variable
66 '    TRAD                True Radians
68 '    TS                  Temporary variable
70 '    X                    Temporary variable
72 '    XDELTA              Difference in NM for Latitudes
74 '    YDELTA              Difference in NM for Longitudes
76 '
78 ' DATE REVISION INITIALS BRIEF DESCRIPTION OF REVISION
80 ' -----
82 ' 5/27/85  2.0  fc      Corrects for East/South errors
84 ' 9/25/86  2.1  jfg      Converted to Z-Basic/GW-Basic, will also
86 '                          take input in the form DDMM.T like the
88 '                          Low Level program.
89 '3/30/95  3.0  DJM      Read input lat/lon from two files
100 ' COMMON DEFINES (Lines 100-999)
110 DEFDBL A-Z
120 DEFSNG A
130 DEFINT I-K
190 PI = 3.141592653589795# ' Constant for PI
200 R = 180# / PI          ' Constant for radians
210 NM = 6076.12#         ' Constant for Nautical Mile
220 DIM LATS(1023)

```

```

230 DIM LNGS(1023)
240 DIM LATD(1023)
250 DIM LNGD(1023)
260 DIM TIMESTAMP1$(1023)
270 DIM TIMESTAMP2$(1023)
1000 '
1010 ' MAIN PROGRAM (LINES 1000-9990)
1020 '
1030 CLS
1040 PRINT TAB(9);
1050 PRINT " PROGRAM TO CONVERT FROM LAT/LON-LAT/LON TO BEARING/RANGE "
1060 PRINT : PRINT TAB(30); "<Version: "; VER$; ">"
1100 '***** put gosub here *****
1110 GOSUB 11000
1121 '*****
1130 INPUT "ENTER NAME OF OUTPUT FILE"; OUTFILE$
1140 OPEN OUTFILE$ FOR OUTPUT AS #3
1200 FOR i = 1 TO numberofpoints
1310 MIDLAT = ABS((LATS(i) + LATD(i)) / 2) / R'Compute mid-latitude in radians
1320 YDELTA = ABS(LATS(i) - LATD(i)) * 60 'Compute lat. difference in NM
1330 XDELTA = (ABS(LNGS(i) - LNGD(i)) * 60) * COS(MIDLAT)'Compute lon. difference in NM
1340 RANGE = SQR(XDELTA ^ 2 + YDELTA ^ 2) * NM 'Compute range in feet
1350 IF YDELTA = 0 THEN YDELTA = 1E-14 'Avoid /0 error
1360 BEARING = ATN(XDELTA / YDELTA) * R 'Compute bearing
1370 IF LATS(i) <= LATD(i) AND LNGD(i) <= LNGS(i) THEN BEARING = BEARING ' QUADRANT I
1380 IF LATS(i) > LATD(i) AND LNGD(i) < LNGS(i) THEN BEARING = 180 - BEARING' QUADRANT II
1390 IF LATS(i) >= LATD(i) AND LNGD(i) >= LNGS(i) THEN BEARING = 180 + BEARING' QUADRANT
III
1400 IF LATS(i) < LATD(i) AND LNGD(i) > LNGS(i) THEN BEARING = 360 - BEARING' QUADRANT IV
1403 IF BEARING > 360 THEN BEARING = BEARING - 360
1407 IF BEARING <= 0 THEN BEARING = 360 + BEARING
1410 PRINT : PRINT : PRINT "True Bearing = "; : PRINT USING "###.## Degrees"; BEARING
1420 PRINT "Range = "; : PRINT USING "##### Feet (###.# NM)"; RANGE; RANGE / NM
1430 PRINT #3, BEARING, RANGE, TIMESTAMP2$(i)
1490 NEXT i
1495 CLOSE #3
1500 SYSTEM 'END OF MAIN PROGRAM
10000 '
10010 ' *** PROGRAM SPECIFIC SUBROUTINES (LINES 10000-31999) ***
10020 '
10030 '
10040 '
10050 '
10060 ' This subroutine converts degrees, minutes, & seconds to decimal degrees
10070 '
10080 DMS = DMS + 1E-14'Factor to prevent rounding errors
10085 DG = FIX(DMS / 100)
10090 X = DMS - (DG * 100)
10100 DM = X / 60
10110 DDD = DG + DM
10130 RETURN 'END OF DDMM.T TO D.DDDD SUBROUTINE
10140 '

```

```

11000 ***** wing's input file *****
11090 CLS
11095 i = 0
11100 LOCATE 1, 1: INPUT "Enter wingman's filename (include path)"; filename$
11110 OPEN filename$ FOR INPUT AS #1
11112 WHILE EOF(1) = 0
11115 i = i + 1
11120 INPUT #1, t$
11125 LATS(i) = VAL(MID$(t$, 3, 9)): LNGS(i) = -1 * VAL(MID$(t$, 15, 11))
11126 TIMESTAMP1$(i) = MID$(t$, 37, 8)
11127 t2 = VAL(MID$(TIMESTAMP1$(i), 7, 2))
11130 IF (((t2 / 2) = INT(t2 / 2)) OR (i = 1)) THEN 11145
11131 t1 = VAL(MID$(TIMESTAMP1$(i - 1), 7, 2))
11132 LATS(i) = ((LATS(i) - LATS(i - 1)) / (t2 - t1)) * ((t2 - 1) - t1) + LATS(i - 1)
11134 LNGS(i) = ((LNGS(i) - LNGS(i - 1)) / (t2 - t1)) * ((t2 - 1) - t1) + LNGS(i - 1)
11136 TIMESTAMP1$(i) = MID$(TIMESTAMP1$(i), 1, 6) + MID$(STR$(t2 - 1), 2, 2)
11145 WEND
11150 FOR J = 1 TO i
11155 PRINT "lat=>"; LATS(J): PRINT "long=>"; LNGS(J)
11160 NEXT J
11165 CLOSE #1
11170 ***** lead's input file *****

```

```

12090 CLS
12095 i = 0
12100 LOCATE 1, 1: INPUT "Enter lead's filename (include path)"; filename$
12110 OPEN filename$ FOR INPUT AS #2
12112 WHILE EOF(2) = 0
12115 i = i + 1
12120 INPUT #2, t$
12122 LATD(i) = VAL(MID$(t$, 3, 9)): LNGD(i) = -1 * VAL(MID$(t$, 15, 11))
12124 TIMESTAMP2$(i) = MID$(t$, 37, 8)
12127 t2 = VAL(MID$(TIMESTAMP2$(i), 7, 2))
12130 IF (((t2 / 2) = INT(t2 / 2)) OR (i = 1)) THEN 12145
12131 t1 = VAL(MID$(TIMESTAMP2$(i - 1), 7, 2))
12132 LATD(i) = ((LATD(i) - LATD(i - 1)) / (t2 - t1)) * ((t2 - 1) - t1) + LATD(i - 1)
12134 LNGD(i) = ((LNGD(i) - LNGD(i - 1)) / (t2 - t1)) * ((t2 - 1) - t1) + LNGD(i - 1)
12136 TIMESTAMP2$(i) = MID$(TIMESTAMP2$(i), 1, 6) + MID$(STR$(t2 - 1), 2, 2)
12145 WEND
12146 numberofpoints = i: J = 1
12147 WHILE (J < numberofpoints)
12150 PRINT "lat=>"; LATD(J): PRINT "long=>"; LNGD(J)
12152 t1 = VAL(MID$(TIMESTAMP1$(J), 7, 2)): t2 = VAL(MID$(TIMESTAMP2$(J), 7, 2))
12155 IF (t1 = t2) THEN 12160
12157 IF (t1 < t2) THEN GOSUB 20000 'DELETE AN ITEM FROM ARRAY 1
12158 IF (t1 > t2) THEN GOSUB 21000 'DELETE AN ITEM FROM ARRAY 2
12160 J = J + 1
12162 WEND
12185 CLOSE #2
12190 FOR J = 1 TO numberofpoints
12192 IF TIMESTAMP1$(J) = TIMESTAMP2$(J) THEN 12198
12194 PRINT "TIME DISCREPANCY: "; TIMESTAMP1$(J), TIMESTAMP2$(J)
12198 NEXT J
12200 RETURN

```

```
20000 '***** SUBROUTINE TO REDUCE ONE ELEMENT FROM ARRAY 1 *****
20010 FOR k = J TO numberofpoints - 1
20030 LATS(k) = LATS(k + 1): LNGS(k) = LNGS(k + 1): TIMESTAMP1$(k) = TIMESTAMP1$(k + 1)
20040 NEXT k
20050 numberofpoints = numberofpoints - 1
20060 RETURN
21000 '***** SUBROUTINE TO REDUCE ONE ELEMENT FROM ARRAY 2 *****
21010 FOR k = J TO numberofpoints - 1
21030 LATD(k) = LATD(k + 1): LNGD(k) = LNGD(k + 1): TIMESTAMP2$(k) = TIMESTAMP2$(k + 1)
21040 NEXT k
21050 numberofpoints = numberofpoints - 1
21060 RETURN
19240 ' END PROGRAM "OFFSETS.BAS"
```

This page intentionally left blank.

**APPENDIX C**  
**TCAS CONTRACT CHANGE PROPOSAL**

This page intentionally left blank .

<b>CONTRACT CHANGE PROPOSAL/TASK CHANGE PROPOSAL</b>		Number: CCP-MDC-TIATS.0036A1
		Date: 23 JANUARY 1995
		PAGE 1 OF 2 PAGES
<b>TITLE:</b> SIMULATED IFR RADAR TRAIL CAPABILITY		
<b>ITEM(S) AFFECTED</b> (Identify contractual requirement(s) affected): CONTRACT No. F33657-89-C-0002 ATTACHMENT 1, AIR VEHICLE STATEMENT OF WORK		
<b>NEED</b> (Explain benefit(s) of making the change and impact of not making change):  Air Force pilot training now uses the Tactical Air Navigation (TACAN) displayed on the Multi-Functional Display (MFD) as a simulated beacon radar since this closely approximates the display for a beacon radar. The present system is only certified for Visual Flight Rules (VFR). However, Instrument Flight Rules (IFR) conditions are encountered during transfer to the training area when it may be necessary to pass through cloud decks. In order to demonstrate IFR capability, Air Force letter ASC/YTK-94-302, dated 17 October 1994, requested the Contractor submit a Contract Change Proposal (CCP) to support USAF testing of the Terrain Collision Avoidance System's (TCAS) adaptability to maintain a safe 1 mile separation for two ship station keeping under IFR conditions. The Test Pilot School (TPS) at Edwards AFB, will provide the testing instrumentation and test efforts necessary to confirm the desired operational performance for flying under IFR conditions.		
<b>DESCRIPTION OF PROPOSED CHANGE</b> (Enter a detailed description of the proposed task including man-hours and any special equipment required):  The Contractor shall prepare modification drawings to support the modification of two post DD-250ed test aircraft with ECPs 01, 29 and 34 installed, along with technical support to the USAF for test planning and review boards. The Contractor shall identify and provide on-site the "most-probable" spares and selected support equipment required for normal maintenance support of two T-1A aircraft. Other "as-needed" spares or support equipment shall be shipped overnight from the Contractor to Edwards AFB. The Contractor shall also provide appropriate on-site technicians for routine maintenance support of the two T-1A aircraft during the test program. The technicians will perform the aircraft modification prior to the start of testing and demodification of the aircraft after completion of testing to return the two aircraft to their original configuration. This support shall not exceed forty-two calendar days. The Contractor shall provide support for two meetings at Edwards AFB. Continued:		
<b>ALTERNATIVES TO PROPOSED CHANGE</b> (Explain reasons for/against each alternative, and the cost): None		
<b>COST ESTIMATE</b> (Contract cost adjustment required for the task):  \$179,861.00	<b>SCHEDULE</b> (Enter schedule for completing work and when applicable date for submittal of results)  Period of Performance: Oct 94 thru Jun 95 Maintenance Support at Edwards AFB: Base period - 20 Mar 95 thru 28 Apr 95 Option period - 29 Apr 95 thru 05 May 95	
<b>URGENCY CONSIDERATIONS</b> (When applicable, describe any condition bearing on the urgency of obtaining approval for change) Authorization to Proceed: 30 January 1995		

COMPUTER GENERATED

CONTRACT CHANGE PROPOSAL/TASK CHANGE PROPOSAL

Number:  
CCP.MTC.T1ATR0036A1

Date:  
23 JANUARY 1995

PAGE 2 OF 2 PAGES

TITLE:  
SIMULATED IFR RADAR TRAIL CAPABILITY

Continued:

The aircraft are currently expected to arrive at Edwards AFB on 20 March 1995. The nominal period for Aircraft Mod, Flight Test and Aircraft Demod is from 20 Mar 95 thru 28 Apr 95 (42 days). The option week is from 29 Apr 95 thru 06 May 95.

The Contractor spares support shall be based on:

- a) a maximum of 25 flight test hours for the two T-1A aircraft combined.
- b) aircraft minimum equipment required for VFR flight.
- c) safety of flight.
- d) spares affecting the outcome of the test.
- e) spares and support equipment shall be provided only on a non-interference basis. Items will not be provided in the event T-1A aircraft production or operation of USAF fielded aircraft could be affected.

The Contractor will provide for collecting, inventorying, packaging and shipping of spares and support equipment to Edwards AFB. At the completion of testing, the Contractor shall pack, ship and return all remaining items to the Contractor's facility. All spare parts and support equipment shall remain the Contractor's property until installed on the USAF T-1A aircraft. All items removed from the USAF T-1A aircraft as a result of installing a Contractor owned spare part shall become the property of the Contractor.

Modification/demodification of the MFD is limited to:

- Mod - Add a wire between PIN 1H and a ground pin to allow display of TCAS information on the MFD at the reduced range scales.
- Demod - Remove wire. Conduct EFIS Operation Checkout per 1T-1A-2-34JG-20-1 to confirm proper operation of the MFD.

Modification/demodification of the Global Positioning System (GPS) is limited to:

- Mod - Remove ADF antenna from aircraft. Fabricate an adapter plate to duplicate profile of the ADF antenna mounting base. USAF to provide GPS antenna for Contractor installation. Wires/cable from the GPS antenna shall be routed into the aircraft interior in a non-permanent method for connection to the hand held GPS unit. A cabin pressurization leak check shall be performed.
- Demod - Remove interior wires/cable to the hand held GPS unit as well as the GPS antenna and adapter plate. Reinstall ADF antenna. Checkout ADF system operation per T.O. 1T-1A-2-34JG-50-1. Perform a cabin pressurization leak check.

The USAF shall provide and maintain all instrumentation and test equipment required for the test program. The USAF shall be responsible to conduct the test and for all test data, analysis and reports. The USAF shall provide the Contractor with on-site base support for limited access to required facilities and for limited use of selected T-1A support equipment.

If an option week is required, the Contractor shall provide the same level of support as described above. If the option week is required, the last sentence in the proposed SOW paragraph 1050.15 would read, "This support shall not exceed forty-nine calendar days".

COMPUTER GENERATED

000109

McDonnell Douglas Corporation  
McDonnell Douglas Training Systems  
12301 Missouri Bottom Road  
Hazelwood, Missouri 63042

Date: 23 JANUARY 1995

Page: 1 OF 1

Cage No. OPVX4

PROPOSED  
CONTRACT DOCUMENT CHANGE NOTICE

NO. 0058R1

REV 183

1. Document Number and Title:

ATTACHMENT 1, AIR VEHICLE STATEMENT OF WORK

2. ECP or CCP No.:

CCP-MDC-T1ATS-0036A1

3. Contract No.:

F33657-89-C-0002

4. DOCUMENT PAGE NO.

18.2

5. Text Change

1. add paragraph 1050.15 as follows:

"1050.15 SIMULATED IFR RADAR TRAIL CAPABILITY.

The Contractor shall prepare modification drawings to support the modification <sup>of</sup> to two post DD-250ed test aircraft with ECP 01, 29 and 34 installed, along with technical support to the USAF for test planning and review boards. The Contractor shall identify and provide on-site the "most-probable" spares and selected support equipment required for normal maintenance support of two T-1A aircraft. Other "as-needed" spares or support equipment shall be shipped overnight from the Contractor to Edwards AFB. The Contractor shall also provide appropriate on-site technicians for routine maintenance support of the two T-1A aircraft during the test program. The technicians will perform the aircraft modification prior to the start of testing and demodification of the aircraft after completion of testing to return the two aircraft to their original configuration. This support shall not exceed forty-two calendar days.

000110

\*\* TOTAL PAGE 24 \*\*

This page intentionally left blank .

## LIST OF ABBREVIATIONS AND SYMBOLS

A/A	Air-to-Air
ADF	Automatic Direction Finding
AETC	Air Education and Training Command
AFB	Air Force Base
AFFTC	Air Force Flight Test Center
AGL	Above Ground Level
ASC	Aeronautical Systems Center
ATC	Air Traffic Control
CA	California
C/A	Coarse Acquisition
EPE	Estimated Position Error
GPS	Global Positioning System
HQ	Headquarters
IFF	Identification, Friend or Foe
IFR	Instrument Flight Rules
IMC	Instrument Meteorological Conditions
KIAS	Knots Indicated Airspeed
MCT	Maximum Continuous Thrust
MFD	Multi-Function Display
N <sub>1</sub>	Percent engine speed in rotations per minute
OH	Ohio
PA	Pressure Altitude
SKE	Station Keeping Equipment
SWAT	Subjective Workload Assessment Technique
TA	Traffic Advisory
TACAN	Tactical Air Navigation
TCAS	Traffic Alert/Collision Avoidance System
TECCS	Technical Evaluation Command and Control System
TSPI	Time Space Position Information
TPS	Test Pilot School
USAF	United States Air Force
UTC	Universal Time Code
VMC	Visual Meteorological Conditions

This page intentionally left blank .

## DISTRIBUTION LIST

ASC/YT  
Wright-Patterson AFB OH 45433  
10 copies

412TW/TSSH  
Edwards AFB CA 93523  
1 copy

Defense Technical Information Center  
DTIC/TCA, Bldg 5  
Cameron Station  
Alexandria VA 22304-6145  
2 copies

USAF TPS/EDT  
Edwards AFB CA 93523  
10 copies

AUL/LSE  
Bldg 1405, 600 Chennault Circle  
Maxwell AFB AL 36112-6424  
1 copy

FASTC/TAA  
4115 Hebble Creek Rd, Ste 23  
Wright-Patterson AFB OH 45433-5627  
1 copy

HQ/AETC  
Randolph AFB TX 78510  
3 copies

AFFTC/HO  
Edwards AFB CA 93523  
1 copy

412 Test Wing  
Edwards AFB CA 93523  
5 copies

412TW/TSV  
Edwards AFB CA 93523  
4 copies

412TW/TSTL  
Edwards AFB CA 93523  
3 copies

This page intentionally left blank.