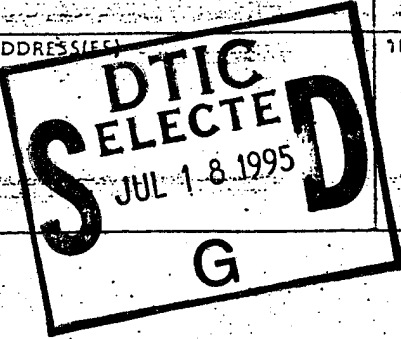

Public reporting burden for this collection of information is estimated to average 1 hour per response, including the time for reviewing instructions, searching existing data sources, gathering and maintaining the data needed, and completing and reviewing the collection of information. Send comments regarding this burden estimate or any other aspect of this collection of information, including suggestions for reducing this burden, to Washington Headquarters Services, Directorate for Information Operations and Reports, 1215 Jefferson Davis Highway, Suite 1204, Arlington, VA 22202-4302, and to the Office of Management and Budget, Paperwork Reduction Project (0704-0188), Washington, DC 20503.

1. AGENCY USE ONLY (Leave blank)		2. REPORT DATE June 1995	3. REPORT TYPE AND DATES COVERED																					
4. TITLE AND SUBTITLE Reliability Index versus Safety Factor Of Structures			5. FUNDING NUMBERS																					
6. AUTHOR(S) R. Brec Wilshusen																								
7. PERFORMING ORGANIZATION NAME(S) AND ADDRESS(ES) AFIT Students Attending: University of Colorado			8. PERFORMING ORGANIZATION REPORT NUMBER AFIT/CI/CIA 95-046																					
9. SPONSORING/MONITORING AGENCY NAME(S) AND ADDRESS(ES) DEPARTMENT OF THE AIR FORCE AFIT/CI 2950 P STREET, BDLG 125 WRIGHT-PATTERSON AFB OH 45433-7765			10. SPONSORING/MONITORING AGENCY REPORT NUMBER																					
																								
11. SUPPLEMENTARY NOTES																								
12a. DISTRIBUTION/AVAILABILITY STATEMENT Approved for Public Release IAW AFR 190-1 Distribution Unlimited BRIAN D. GAUTHIER, MSgt, USAF Chief Administration			12b. DISTRIBUTION CODE																					
13. ABSTRACT (Maximum 200 words)			<table border="1"> <tr> <td colspan="2">Accession For</td> </tr> <tr> <td>NTIS CRA&I</td> <td><input checked="" type="checkbox"/></td> </tr> <tr> <td>DTIC TAB</td> <td><input type="checkbox"/></td> </tr> <tr> <td>Unannounced</td> <td><input type="checkbox"/></td> </tr> <tr> <td>Justification</td> <td></td> </tr> <tr> <td colspan="2">By _____</td> </tr> <tr> <td colspan="2">Distribution/</td> </tr> <tr> <td colspan="2">Availability Codes</td> </tr> <tr> <td>Dist</td> <td>Avail and/or Special</td> </tr> <tr> <td>A-1</td> <td></td> </tr> </table>		Accession For		NTIS CRA&I	<input checked="" type="checkbox"/>	DTIC TAB	<input type="checkbox"/>	Unannounced	<input type="checkbox"/>	Justification		By _____		Distribution/		Availability Codes		Dist	Avail and/or Special	A-1	
			Accession For																					
			NTIS CRA&I	<input checked="" type="checkbox"/>																				
			DTIC TAB	<input type="checkbox"/>																				
			Unannounced	<input type="checkbox"/>																				
Justification																								
By _____																								
Distribution/																								
Availability Codes																								
Dist	Avail and/or Special																							
A-1																								
			DTIC QUALITY INSPECTED 5																					
14. SUBJECT TERMS			15. NUMBER OF PAGES 300 (Est)																					
			16. PRICE CODE																					
17. SECURITY CLASSIFICATION OF REPORT	18. SECURITY CLASSIFICATION OF THIS PAGE	19. SECURITY CLASSIFICATION OF ABSTRACT	20. LIMITATION OF ABSTRACT																					

Reliability Index versus Safety Factor of Structures

by

R. Brec Wilshusen, Captain, USAF
Air Force Institute of Technology (CI)

M.S. Civil (Structural) Engineering, College of Engineering and Applied Science
University of Colorado--Boulder, 1995

B.S. Civil Engineering, College of Engineering and Technology
University of Nebraska--Lincoln, 1990

Master's Report **ABSTRACT**

In measuring structural safety, the reliability index concept is, by far, more explicit than the usual safety factor. The probabilistic reliability index incorporates uncertainty of member load and capacity into a comprehensive model, while the deterministic safety factor is normally the ratio of the two. The result, β , provides the engineer with a probability of failure, independent of the design criteria. The probabilistic method is especially useful in determining reliability under overload conditions; it also provides a transition between the *Allowable Stress Design (ASD)* mentality and the *Load & Resistance Factor Design (LRFD)* process.

This report provides the engineer with a functional means of visualizing the interaction of uncertain loads on an element. Realistically, all loads and capacities are random, with a most frequent expected value and a distribution (range of possibilities) on either side of the mean. The reliability index function is a product of the mean values of the total load (\bar{S}) and capacity (\bar{R}), along with uncertainty in each (σ_s , σ_r). ASD establishes a failure value projecting capacity as a multiple of the load, depicting failure at the point where load exceeds capacity ($R < S$). ASD cannot account for any safety or reserve strength in an overload condition, but the model outlined in this report--the improvement in structural mechanics--can probabilistically determine structural safety for any loading condition. LRFD focuses on incorporating reserve strength and ductility into design.

The crux of this report centers on graphically packaging the model's parameters and isolating each in turn. The result provides the engineer with a quick, direct means to correlate a design safety factor to reliability. A given safety factor can have any value for the reliability index because of the effects of uncertainty. Uncertainty--the precision associated with all the components--has everything to do with structural safety. The *Reliability Interaction Charts* plot the reliability index versus the safety factor and the two uncertainties in seven different forms. These graphs represent both capacity and load as Normal (Gaussian) variates, then both as Log-Normal variates, and finally compares each case to identify the relative conservatism of these distributions.

This analysis must be applied into common practice. The report highlights several examples. To aid the readers visualization, this report also contains reliability diagrams on six sample beam elements. This analysis takes the standard design analysis of shear and moment diagrams one step further, fomenting the concept of the variance diagrams and ultimately, the reliability diagram. This presentations intends to introduce the concepts and applications of reliability based design and alleviate the engineer's fears of probabilistic mechanics in the LRFD code.

19950710 006

Reliability Index versus Safety Factor of Structures

by

R. Brec Wilshusen, Captain, USAF

B.S., College of Engineering and Technology

University of Nebraska--Lincoln, 1990

A report submitted to the
Faculty of the Graduate School of the
University of Colorado in partial fulfillment
of the requirements for the degree of
Master of Science
Department of Civil, Environmental,
and Architectural Engineering

1995

This report for the Master of Science degree by

R. Brec Wilshusen

has been approved for the

Department of

Civil, Environmental, and Architectural Engineering

by

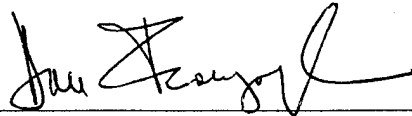

Dr. Dan M. Frangopol

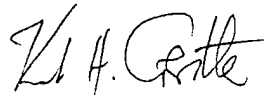

Dr. Kurt H. Gerstle

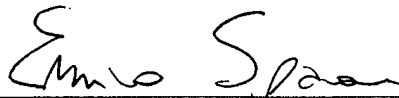

Dr. Enrico Spacone

Date April 24, 1995

Reliability Index versus Safety Factor of Structures

Executive Summary

In measuring structural safety, the reliability index concept is, by far, more explicit than the usual safety factor. The probabilistic reliability index incorporates uncertainty of member load and capacity into a comprehensive model, while the deterministic safety factor is normally the ratio of the two. The result, β , provides the engineer with a probability of failure, independent of the design criteria. The probabilistic method is especially useful in determining reliability under overload conditions; it also provides a transition between the *Allowable Stress Design (ASD)* mentality and the *Load & Resistance Factor Design (LRFD)* process.

This report provides the engineer with a functional means of visualizing the interaction of uncertain loads on an element. Realistically, all loads and capacities are random, with a most frequent expected value and a distribution (range of possibilities) on either side of the mean. The reliability index function is a product of the mean values of the total load (\bar{S}) and capacity (\bar{R}), along with uncertainty in each (σ_s, σ_r). ASD establishes a failure value projecting capacity as a multiple of the load, depicting failure at the point where load exceeds capacity ($R < S$). ASD cannot account for any safety or reserve strength in an overload condition, but the model outlined in this report--the improvement in structural mechanics--can probabilistically determine structural safety for any loading condition. LRFD focuses on incorporating reserve strength and ductility into design.

The crux of this report centers on graphically packaging the model's parameters and isolating each in turn. The result provides the engineer with a quick, direct means to correlate a design safety factor to reliability. A given safety factor can have any value for the reliability index because of the effects of uncertainty. Uncertainty--the precision associated with all the components--has everything to do with structural safety. These effects are the focus of sections 1 and 5 of the main body of the report.

The main offering to the practicing engineer are the *Reliability Interaction Charts*. These plot the reliability index versus the safety factor and the two uncertainties in seven different forms. Discussion of each is contained in section 2 and shown at Appendix A. These graphs represent both capacity and load as Normal (Gaussian) variates, then both as Log-Normal variates, and finally compares each case to identify the relative conservatism of these distributions. Another aspect of this report tries to direct the engineer to find realistic applications. Examples are discussed in section 4.

To assist the reader in learning more about probability, this report highlights several examples providing reliability diagrams on six sample beam elements. The analysis process is detailed in section 3, but all are shown in their entirety at Appendix B. This report aids the engineers visualization of the concepts. This analysis takes the standard design analysis of shear and moment diagrams one step further, fomenting the concept of the variance diagrams and ultimately, the reliability diagram.

This analysis must be applied into common practice. This presentations intends to introduce the concepts and applications of reliability based design and alleviate the engineer's fears of probabilistic mechanics in the LRFD code. This method not only explicitly quantifies realistic failure probabilities, but leads to maximizing engineering benefits and minimizes engineering cost.

Reliability Index versus Safety Factor of Structures

Table of Contents

<i>i</i>	Executive Summary
<i>ii</i>	Figures and Tables
<i>iii</i>	Notation
1.0	Probabilistic Structural Mechanics
1.1	Reliability Index vs Safety Factor in an Engineering Model
1.2	Random Loads and Load Effects
2.0	Reliability Interaction Charts
2.1	Chart Format and Types
2.1.1	<i>Reliability Index</i>
2.1.2	<i>Reliability Index vs. Safety Factor</i>
2.1.3	<i>Safety Factor</i>
2.1.4	<i>Reliability Indices</i>
2.2	Comparison and Degrees of Conservatism
3.0	Beam under Random Loads
3.1	Reliability Analysis Step
3.2	Design Step for Target Reliability
4.0	Reliability Chart Applications
4.1	Structural Analysis Application
4.2	Design Review Applications
4.3	Damage Assessment Application
5.0	Probabilistic Improvements on Safety Factors
5.1	Codified Design Discussion
5.2	Probabilistic Improvements Summary

References

Appendices

Appendices List

- A. Probability Interaction Charts
 - A1. **Design for Reliability Index**
 - A1.1 Normal Case
 - A1.2 Log-Normal Case
 - B1.3 Normal/Log-Normal Comparison
 - A2. **Compare Reliability Index vs. Safety Factor**
 - A2.1 Normal Case
 - A2.2 Log-Normal Case
 - A2.3 Normal/Log-Normal Comparison
 - A3. **Design for Safety Factor**
 - A3.1 Normal Case
 - A3.2 Log-Normal Case
 - A3.3 Normal/Log-Normal Comparison
 - A4. **Evaluate Reliability Indices**
 - A4.1 Normal Case
 - A4.2 Log-Normal Case
 - A4.3 Normal/Log-Normal Comparison

- B. Sample Loaded Members
 - B1. Simply Supported--3 Concentrated Loads
 - B2. Simply Supported, Left Cantilever--2 Concentrated, 1 Uniform Loads
 - B3. Simply Supported, Double Cantilever--1 Concentrated, 2 Uniform Loads
 - B4. Simply Supported, Right Cantilever--1 Concentrated, 2 Uniform Loads
 - B5. Indeterminate (1st Degree)--1 Uniform Load
 - B6. Indeterminate (2d Degree)--2 Uniform Loads

- C. Comprehensive Exam Questions
 - C1. Investigate Plastic Behavior on Safety Factor & Reliability Index
 - C2. Summarize Structural Effects of Semi-Rigid Connections

Summary of Figures and Tables

Part 1

- Fig 1.1 Load and Capacity Structural Reliability Model {Bivariate Form}
- Tab 1.1 Parametric Sensitivity of Safety Factor and Reliability Index
- Fig 1.2 Example of Beam under Hypothetical Load (Random Variates)
- Fig 1.3 Shear Uncertainty from Randomly Loaded Beam
- Fig 1.4 Structural Reliability Model {Univariate Form}

Part 2

- Fig 2.1 *Reliability vs V(R), V(S) Interaction Charts*
- Tab 2.1 Form of *Reliability vs V(R), V(S) Interaction Charts*
- Fig 2.2 *Reliability vs Central Safety Factor Interaction Charts*
- Tab 2.2 Form of *Reliability vs Central Safety Factor Interaction Charts*
- Fig 2.3 *Central Safety Factor vs V(R), V(S) Interaction Charts*
- Tab 2.3 Form of *Central Safety Factor vs V(R), V(S) Interaction Charts*
- Fig 2.4 *V(R) vs V(S) Reliability Interaction Charts*
- Tab 2.4 Form of *V(R) vs V(S) Reliability Interaction Charts*
- Fig 2.5 *Reliability vs V(S) Comparison Interaction Charts*
- Tab 2.5 Failure Probability from Reliability Index

Part 3

- Tab 3.1 Reliability Index Functional Requirements
- Fig 3.1 Beam under Random Load [all sample systems]
- Fig 3.2 Beam under Random Load [Sample System 3]
- Tab 3.2 Beam Loads and Correlation
- Tab 3.3 Beam Capacity
- Fig 3.3 Segmented Beam under Random Load
- Fig 3.4 Beam under Random Load: Mean Shear, Moment Diagrams
- Fig 3.5 Beam under Random Load: Shear, Moment Dispersion Diagrams
- Fig 3.6 Beam under Random Load: Shear, Moment Reliability Diagrams (Normal Case)
- Tab 3.4 Minimum Reliability Conditions for Sample Calibration
- Fig 3.7 *Reliability vs Central Safety Factor Interaction Chart* [Beam Application Example]
- Tab 3.5 Target Reliability Adjustment Values for Sample Completion
- Fig 3.8 Beam under Random Load: Shear, Moment Targeted Reliability Diagrams (Normal Case)
- Fig 3.9 Beam under Random Load: Shear, Moment Safety Factor Diagrams

Part 4

- Fig 4.1 *Reliability vs V(S) Interaction Chart* [Engineer's Inspection Example]
- Fig 4.2 *Reliability vs Central Safety Factor Interaction Chart* [Overdesign Effects Example]
- Fig 4.3 Uncertainty Changes in Damage Events
- Fig 4.4 *Reliability vs Central Safety Factor Interaction Chart* [Damage Assessment Example]
- Fig 4.5 *V(R) vs V(S) Reliability Interaction Chart* [Damage Assessment Example]

Summary of Notation

STATISTICS

S \equiv load random variable

R \equiv resistance random variable

X, Z \equiv parametric random variables

$f(X), f(R), f(R-S), f(S)$ \equiv frequency of random value

μ_R, \bar{S} \equiv load mean value

σ_S \equiv load standard deviation

V_S \equiv coefficient of variation of load $\equiv \sigma_S / \bar{S}$

μ_R, \bar{R} \equiv resistance mean value

σ_R \equiv resistance standard deviation

$V(R), V_R$ \equiv coefficient of variation of resistance $\equiv \sigma_R / \bar{R}$

$\mu_{(R-S)}$ \equiv mean value of $\bar{R} - \bar{S}$

$\sigma_{(R-S)}$ \equiv univariate standard deviation of $R-S \equiv \sqrt{\sigma_R^2 + \sigma_S^2}$

β \equiv reliability index $\equiv \mu_{(R-S)} / \sigma_{(R-S)}$

β_T \equiv target reliability index

Θ_0 \equiv central safety factor: mean value ratio $\equiv \bar{R} / \bar{S}$

SF \equiv deterministic safety factor

ρ \equiv correlation coefficient between two parameters (listed as $\rho_{w1, w2}$)

λ, ξ \equiv log-normal parameters

EVENT THEORY

P_s \equiv probability of survival $\equiv 1 - P_f, \Phi(\beta)$

P_f \equiv probability of failure $\equiv P(\text{event}), 1 - \Phi(\beta)$

Φ \equiv normal distribution function

LIMIT STRESS, LOAD PARAMETERS

F_y, f_y \equiv yield stress

P_n \equiv nominal strength

F_a, P_a \equiv allowable stress, load

f_{ult}, P_{ult} \equiv ultimate stress, load (normally used to describe ultimate strength capacity)

f_s \equiv working stress under load conditions

E, I \equiv elastic *Young's Modulus, Moment of Inertia*

PARAMETERS USED IN LOADING SAMPLES, DISCUSSION

w, w_1, w_2, w_3 \equiv uniform loads

P, P_1, P_2, P_3 \equiv concentrated loads

S_{DL}, D \equiv dead load

S_{LVL}, L \equiv live load

V, M \equiv shear, moment

$\bar{S}_V, \sigma_{S(V)}^2$ \equiv mean shear, shear dispersion on beam segment

$\bar{S}_M, \sigma_{S(M)}^2$ \equiv mean moment, moment dispersion on beam segment

a, b \equiv uniform load application distance on beam segment

x_1, x_2, x_3 \equiv segment length of beam (distance from left end)

L \equiv length of beam

1.0 Probabilistic Structural Mechanics

A structural engineer must have a comprehensive view and understanding of the laws of structural mechanics. Models presently used in structural analysis are generally deterministic. Usually engineers simply assume parameters deterministic and proceed. Traditional calculations are straight forward and produce *the* answer--the danger is if some numbers physically *aren't quite what was plugged in*. A deterministic model neglects any uncertainty in nature; the probabilistic model highlights accumulation and counteraction of uncertainties.

An engineer must not forfeit understanding for simplicity. This study provides a means of understanding the rational basis for connecting a probability based *reliability index* with a more simplistic *safety factor*. This report questions the basis for a safety factor, and compares it by illustration to the information gained through the probabilistic reliability index. As the title intends, this report also provides engineers a graphical method to relate the safety factor to the probabilistic reliability index. This study reviews simple beams to highlight the relative difference of the probabilistic reliability index and the simplistic safety factor.

The design and analysis models used in everyday practice are functions of the engineer's expertise, understanding, and design effort. A key concept is a rational basis for defining safety. Is the safety factor experienced based? Is the usual format a simple ratio, an elaborate numerical equation, or simply an educated guess? The safety factor does not provide the analyst much information about, nor explicitly incorporates, uncertainty into the design process.

This report examines three formats for helping the engineer visualize the ways to incorporate physical quantities, uncertainty, and overall reliability into a definable concept. The first is a series of graphs comparing the uncertainties in loads and in resistance. Results show the reliability index can vary widely for a given safety factor. Second are loads and load effects for simple beams. Each example is developed to analyze load effects. Examining single beams is a simplistic approach towards the larger understanding of probabilistic mechanics. Results are for a particular situation, but many similarities can be seen when comparing all the examples. Third are practical applications for the graphs--design (targeting the required reliability) and analysis.

The format for this report presumes the reader is familiar with basic statics, mechanics of materials, structural analysis, and statistical and probabilistic concepts. All the probabilistic and general engineering terms used in this report are defined in the summary of notation, all contained on the previous page; please refer there.

1.1 Reliability Index vs Safety Factor in an Engineering Model

The reliability index concept is far superior to the safety factor. The probabilistic model concept is shown in Figure 1.1. Graphically, the model depicts the probabilistic range of load and

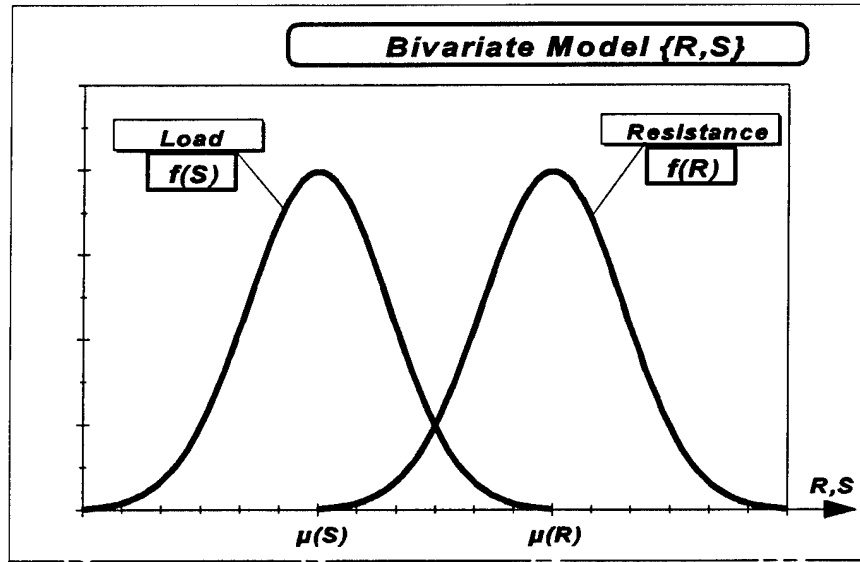

Fig 1.1 Load and Capacity Structural Reliability Model

capacity (resistance) values, as well as the frequency of those random variables. This presents a far more complete picture of structural reliability than that of just a simple safety factor. The reliability index depends on four parameters-- $\mu(R) = \bar{R}$, $\mu(S) = \bar{S}$, σ_R , and σ_S :

$$\beta = \frac{\bar{R} - \bar{S}}{\sqrt{\sigma_R^2 + \sigma_S^2}}$$

This *superiority*, i.e., parametric sensitivity, is illustrated in Table 1.1. A reliability model tells the engineer far more about safety than just the safety factor. The safety factor listed in Table 1.1

Reliability Index, β , vs Safety Factor, Θ_0 , in an Engineering Model		
	$\Theta_0 = \bar{R}/\bar{S}$	β
if \bar{R} increases	increases	increases
if \bar{S} increases	decreases	decreases
if σ_R increases	No Change	decreases
if σ_S increases	No Change	decreases

Table 1.1 Parametric Sensitivity of Safety Factor and Reliability Index

is the ratio of the mean values of R and S, as

$$\theta_0 = \frac{\bar{R}}{\bar{S}}$$

The usual factor of safety is the deterministic safety factor, SF, as a function of the nominal or average values-- R_{AVG} and S_{AVG} . Under regular (normal) conditions:

$$R_{AVG} \approx \bar{R}, \quad S_{AVG} \approx \bar{S}$$

$$\therefore SF = \theta_0$$

These two safety factors generally have the same meaning.

1.2 Random Loads and Load Effects

In economics, demand drives supply; likewise, in design, needs (load) drive capacity--the engineer defines the load and has to find the minimum required resistance. Structures are required to carry a number of different loads. Reactions are contingent upon the loading force, load application (geometry), and the load force intensity. In these cases, all loads and resistances are random variables.

The total load effect is a sum of the individual component load effects. Figure 1.2 offers

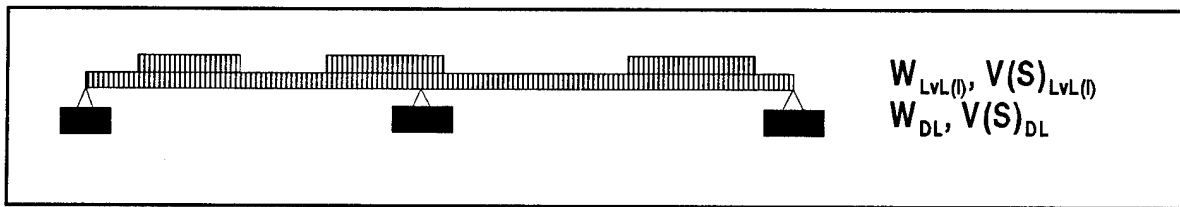

Figure 1.2 Example of Beam under Hypothetical Load (Random Variates)

an example.

This report provides a functional means for visualizing the interaction of uncertain loads on a simple element. The analytical approach outlined in this section defines the rational effects of multiple random loads on a structural member. Each example problem used basic statics analysis to calculate the effects of loads on each segment of the beam. Using the reliability index format, resistance is considered separately from the load effects.

Figure 1.3 offers another example of loading and how the respective uncertainties conceptually spread through the shear diagram along the length of the beam.

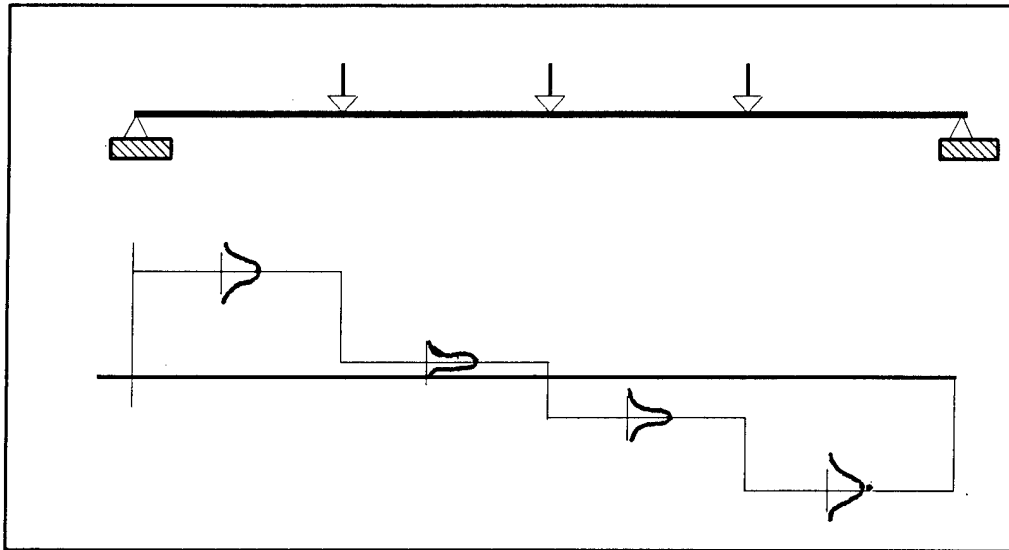

Figure 1.3 Shear Uncertainties from Loaded Beam

Two forms of distribution were studied, first with each pair of random variables modeled as normal variates, then both as log-normal variates. Figure 1.4 illustrates the frequency diagram in the marginal, univariate form. The univariate model, as opposed to the bivariate model shown in Figure 1.1, has the concise and explicit form of illustrating the failure probability as an area— $P_f = P(R-S < 0) = \Omega$.

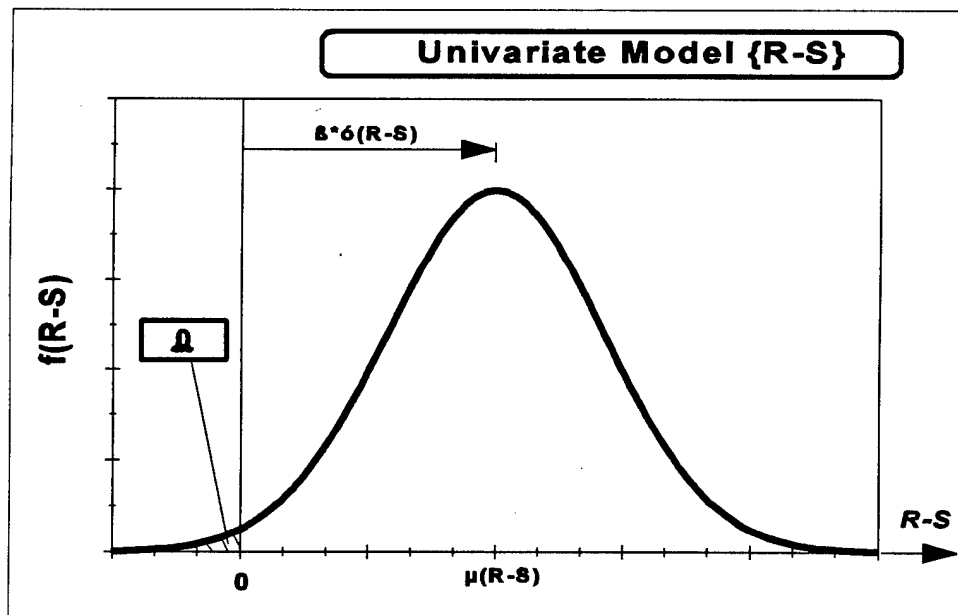

Figure 1.4 Structural Reliability Model

In the normal case form, P_f is a function of the difference of the load and resistance random variables: $P_f = P(R-S < 0)$. In the log-normal case form, P_f is a function of the difference of the natural logarithms of the random variables: $P_f = P(\ln R - \ln S < 0)$.

2.0 Reliability Interaction Charts

All charts are presented at Appendix A. These charts use variations of the reliability index. The reliability equations are modified to reduce the parameters from five to four by the probabilistic safety factor. For the normal and log-normal case, the reliability index is--

$$(a) \text{ Normal case: } \beta = \frac{\theta_0 - 1}{\sqrt{V_R^2 \theta_0^2 + V_S^2}}$$

$$(b) \text{ Log-normal case: } \beta = \frac{\ln \left[\theta_0 \sqrt{\frac{1 + V_S^2}{1 + V_R^2}} \right]}{\sqrt{\ln[(1 + V_R^2)(1 + V_S^2)]}}$$

or $\beta = f\{\theta_0, V(R), V(S)\}$.

2.1 Chart Format and Types

The reliability index is presented as a function of $\theta_0, V(R), V(S)$ as--

$$\beta = f\{\theta_0, V(R), V(S)\} \Rightarrow \text{Reliability vs } V(S)$$

$$\beta = f\{\theta_0, V(S), V(R)\} \Rightarrow \text{Reliability vs } V(R)$$

$$\beta = f\{V(R), V(S), \theta_0\} \Rightarrow \text{Reliability vs Central Safety Factor}$$

$$\beta = f\{V(S), V(R), \theta_0\} \Rightarrow \text{Reliability vs Central Safety Factor}$$

The Central Safety Factor is presented as a function of $\beta, V(R), V(S)$ as--

$$\theta_0 = f\{\beta, V(R), V(S)\} \Rightarrow \text{Central Safety Factor vs } V(S)$$

$$\theta_0 = f\{\beta, V(S), V(R)\} \Rightarrow \text{Central Safety Factor vs } V(R)$$

Additionally to highlight equivalent reliability levels for uncertainty, $V(R)$ and $V(S)$ are related--

$$V(R) = f\{\theta_0, \beta, V(S)\} \Rightarrow V(R) \text{ vs } V(S)$$

The ranges considered are--

$$1.1 \leq \theta_0 \leq 6 \quad (\text{interval of } 0.4, 0.5, \text{ then } 1)$$

$$2 \leq \beta \leq 5 \quad (\text{interval } 0.5)$$

$$0 \leq V(R) \leq 0.3 \quad (\text{interval } 0.1)$$

$$0 \leq V(S) \leq 0.5 \quad (\text{interval } 0.1)$$

2.1.1 Reliability vs Coefficient of Variation: Interaction Charts

Appendix A1 contains the interaction charts of the first two forms of the first set, shown at Figures 2.1a and 2.1b. The normal and log-normal reliability equations are--

$$\text{Normal: } \mu_M = \bar{R} - \bar{S}, \quad \sigma_M = \sqrt{\sigma_R^2 + \sigma_S^2}$$

$$\beta = \frac{\mu_M \left(\frac{1}{\bar{S}} \right)}{\sigma_M \left(\frac{1}{\bar{S}} \right)} = \frac{\frac{\bar{R}}{\bar{S}} - \frac{\bar{S}}{\bar{S}}}{\sqrt{\frac{\sigma_R^2}{\bar{S}^2} + \frac{\sigma_S^2}{\bar{S}^2}}} = \frac{\theta_0 - 1}{\sqrt{V_R^2 \theta_0^2 + V_S^2}}$$

$$\text{Log-Normal: } \mu_M = \lambda_R - \lambda_S, \quad \sigma_M = \sqrt{\xi_R^2 + \xi_S^2}$$

$$\lambda = E(\ln x) = \ln \mu_x - \frac{1}{2} \xi_x^2$$

$$\xi = \sqrt{\text{Var}(\ln x)} \quad \text{Var}(x) = \mu_x^2 [\exp(\xi_x^2) - 1]$$

$$\xi_x^2 = \ln \left(1 + \frac{\sigma_x^2}{\mu_x^2} \right) = \ln(1 + V_x^2)$$

$$\beta = \frac{\left[\ln \bar{R} - \frac{1}{2} \ln(1 + V_R^2) \right] - \left[\ln \bar{S} - \frac{1}{2} \ln(1 + V_S^2) \right]}{\sqrt{\ln(1 + V_R^2) + \ln(1 + V_S^2)}} = \frac{\ln \theta_0 \sqrt{\frac{1 + V_S^2}{1 + V_R^2}}}{\sqrt{\ln[(1 + V_R^2)(1 + V_S^2)]}}$$

For a given ratio (θ_0) of capacity and load and selected incremental values for $V(R)$, Figure 2.1a plots β versus $V(S)$. Figure 2.1b plots β versus $V(R)$ for given values of θ_0 and $V(S)$. Table 2.1 summarizes the format of Figures 2.1a and 2.1b.

	β vs $V(S)$	β vs $V(R)$
Function	β	β
<i>Selected Variable</i>	θ_0	θ_0
<i>Discrete Variable</i>	$V(R)$	$V(S)$
<i>Continuous Variable</i>	$V(S)$	$V(R)$

Table 2.1 Form of Reliability vs $V(S)$, $V(R)$ Interaction Charts

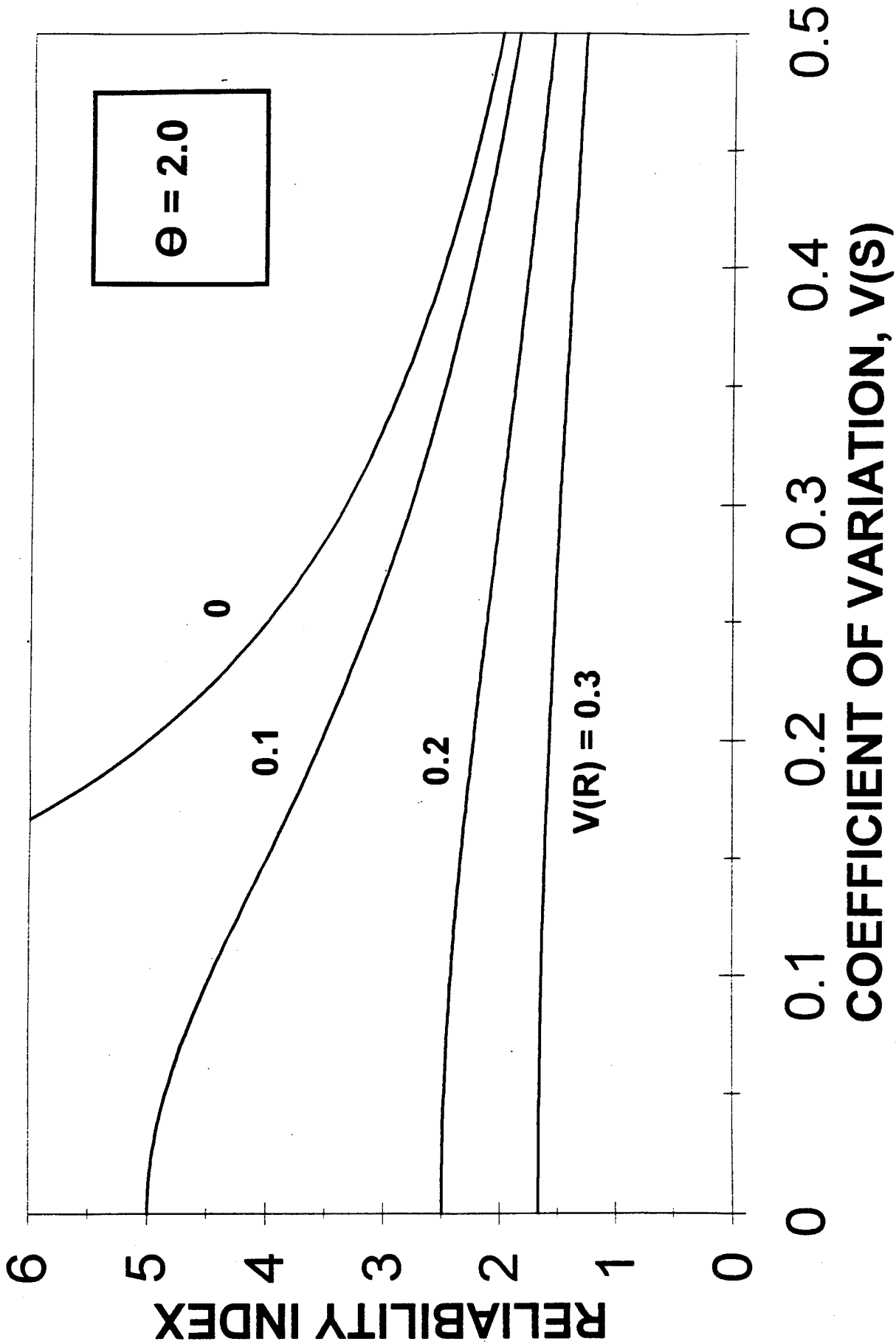

Figure 2.1a

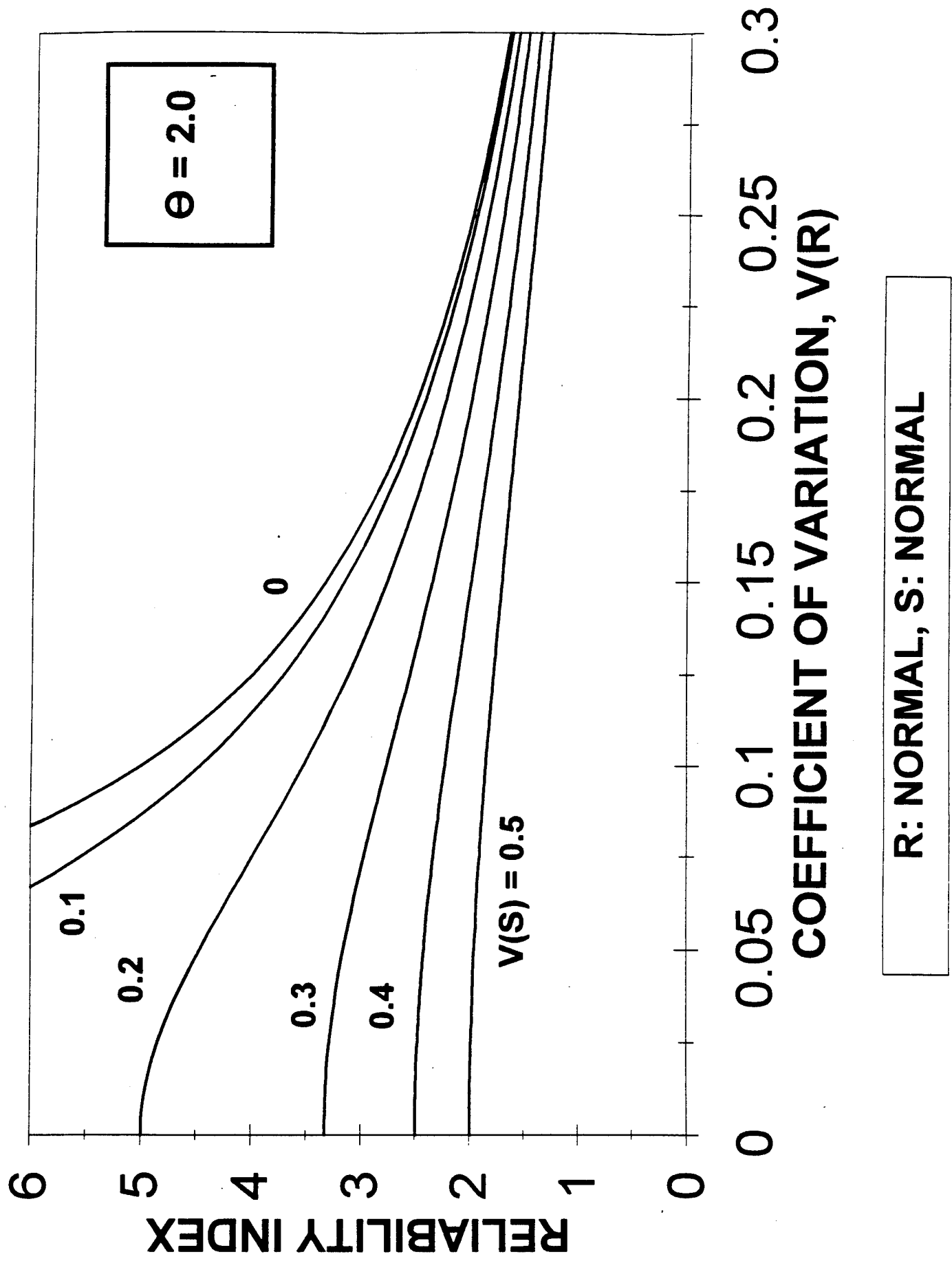

Figure 2.1b

2.1.2 Reliability vs Central Safety Factor: Interaction Charts

Appendix A2 contains the interaction charts of the second pair of forms at Figures 2.2a and 2.2b, relating reliability versus central safety factor for either V(R) or V(S), tabulated as--

	β vs Θ_0	β vs Θ_0
Function	β	β
<i>Selected Variable</i>	V(R)	V(S)
<i>Discrete Variable</i>	V(S)	V(R)
<i>Continuous Variable</i>	Θ_0	Θ_0

Table 2.2 Form of Reliability vs Central Safety Factor) Interaction Charts

2.1.3 Central Safety Factor vs Coefficient of Variation: Interaction Charts

The third pair of interaction charts are contained in Appendix A3.

$$\text{Normal: } \theta_0 = \frac{1 + \beta \sqrt{V_R^2 + V_S^2 - \beta^2 V_R^2 V_S^2}}{1 - \beta^2 V_R^2}$$

$$\text{Log-Normal: } \theta_0 = \exp \left[\beta \sqrt{\ln \left[(1 + V_R^2)(1 + V_S^2) \right]} \right] \sqrt{\frac{1 + V_R^2}{1 + V_S^2}}$$

In this appendix, the central safety factor is plotted against V(R) and V(S), as indicated in Table 2.3 and shown in Figures 2.3a and 2.3b.

	Θ_0 vs V(S)	Θ_0 vs V(R)
Function	Θ_0	Θ_0
<i>Selected Variable</i>	β	β
<i>Discrete Variable</i>	V(R)	V(S)
<i>Continuous Variable</i>	V(S)	V(R)

Table 2.3 Form of Central Safety Factor vs Variation Interaction Charts

2.1.4 Coefficient of Variation: Reliability Interaction Charts

The last reliability form is presented in Appendix A4. The reliability equation is modified to plot uncertainty, V(R) vs V(S), shown at Figure 2.4, to get the reliability levels for a selected

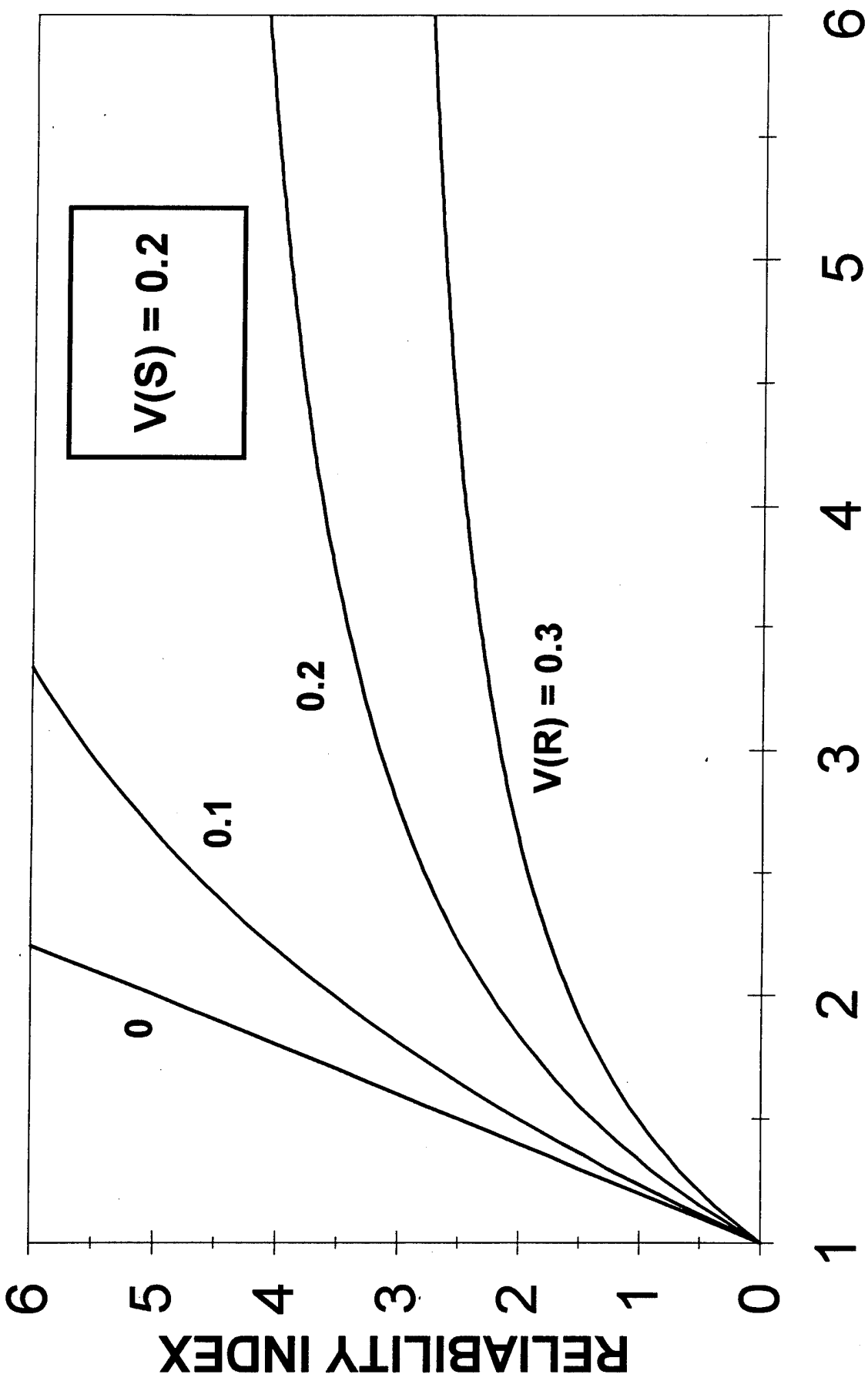
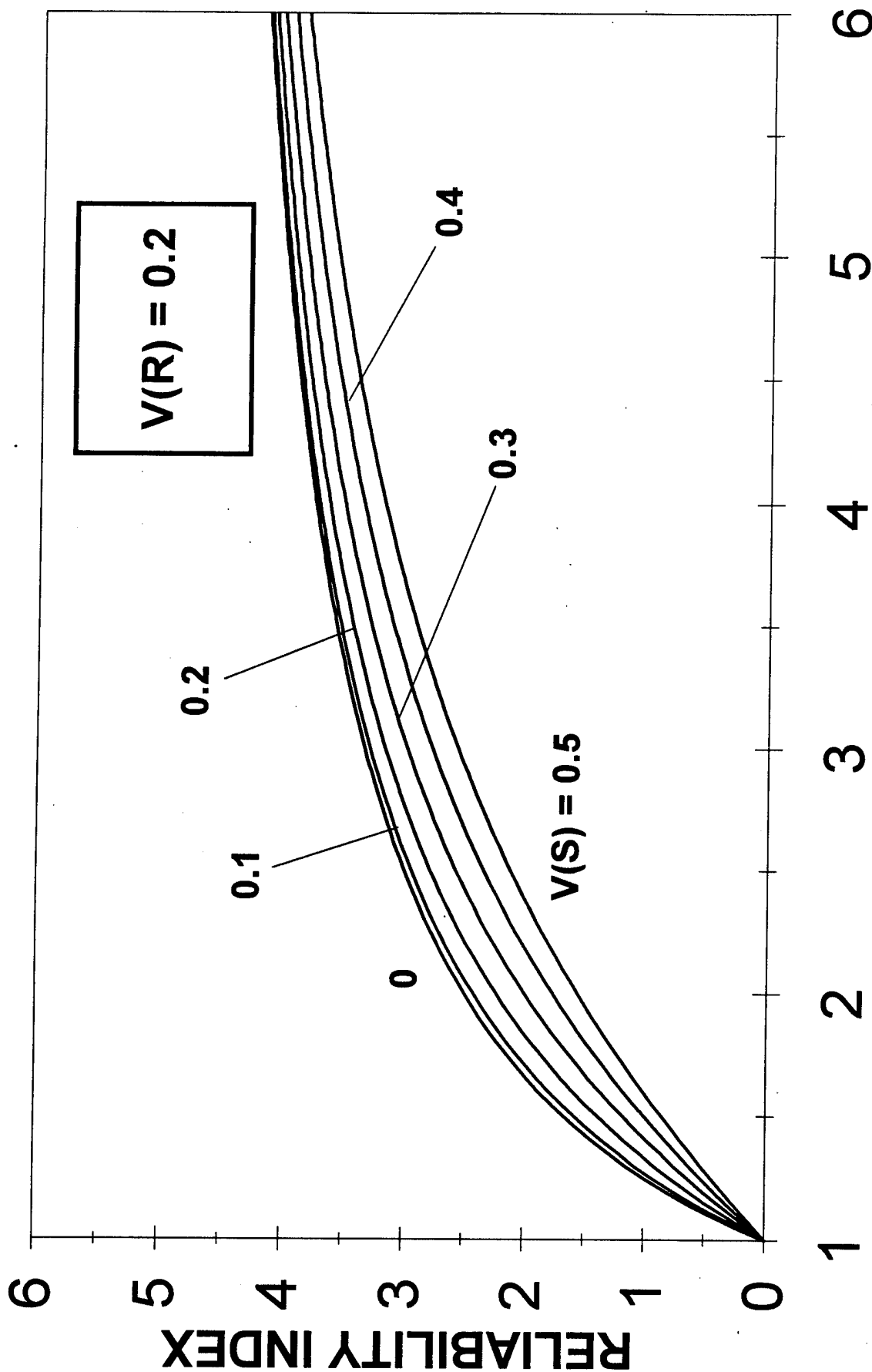

Figure 2.2a



CENTRAL SAFETY FACTOR

R: NORMAL, S: NORMAL

Figure 2.2b

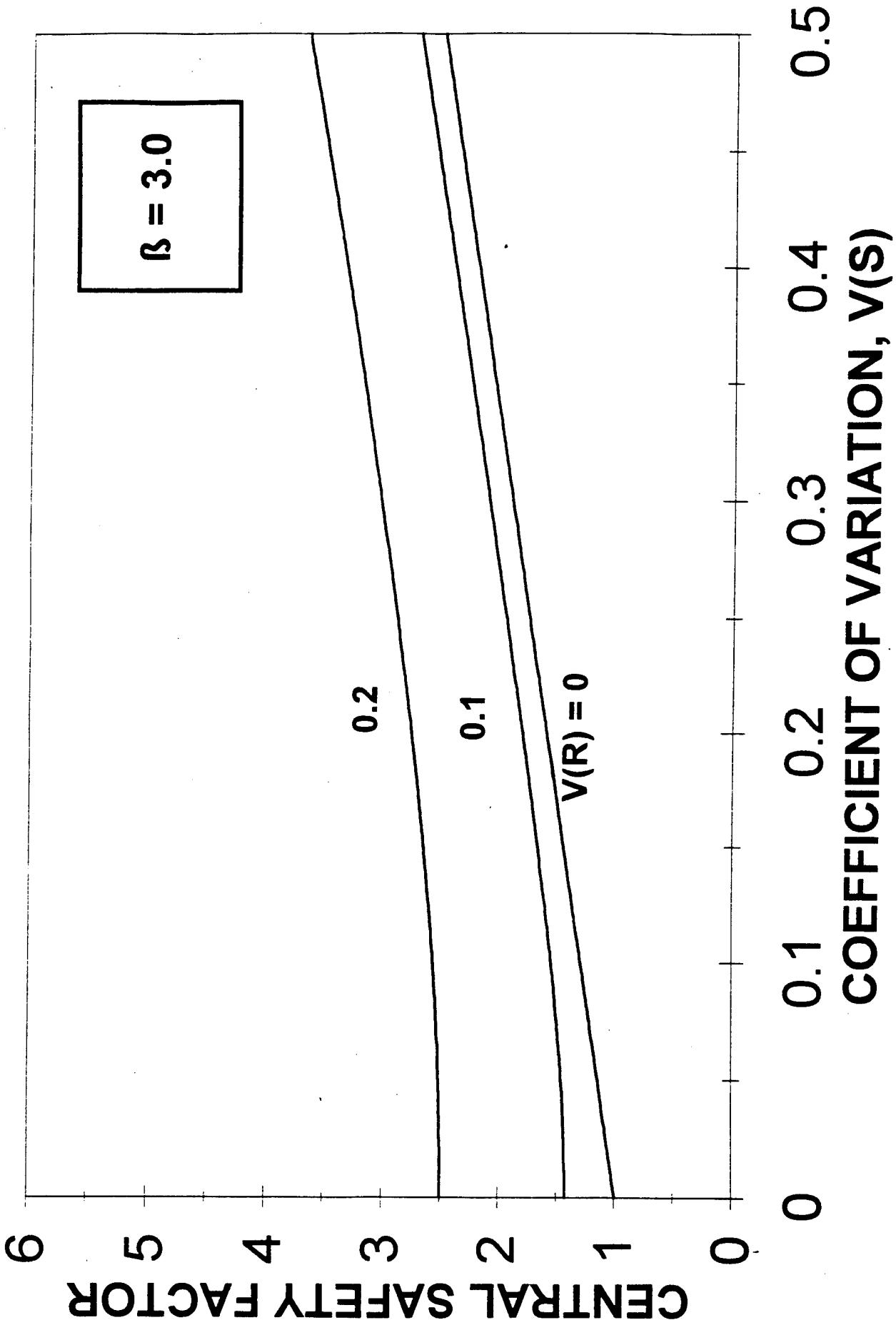

R: NORMAL, S: NORMAL

Figure 2.3a

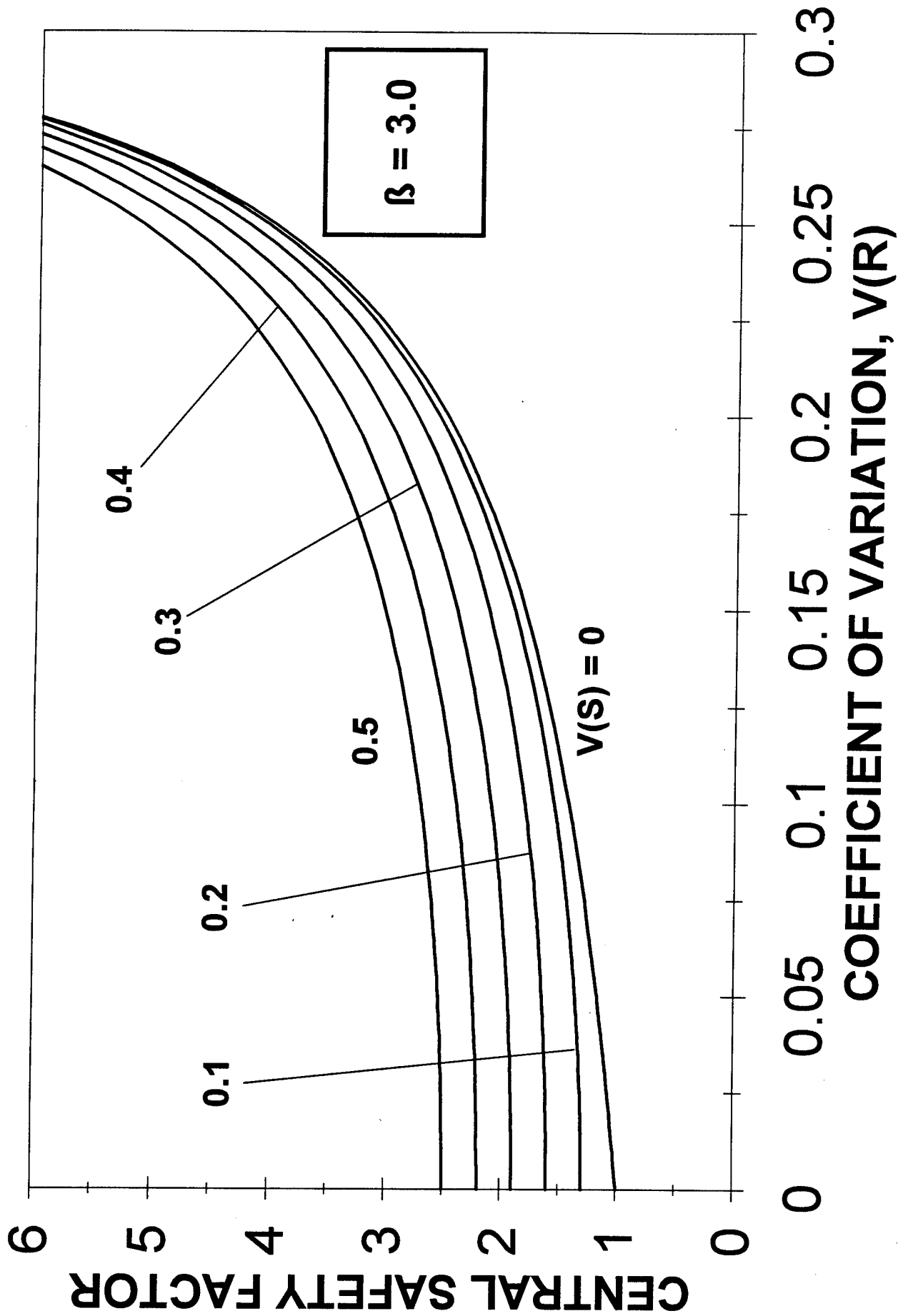

R: NORMAL, S: NORMAL

Figure 2.3b

capacity to load ratio. The equation in the normal case transforms to--

$$V(R)_{Normal} = \sqrt{\frac{\theta_0^2 - 2\theta_0 - \beta^2 V_S^2 + 1}{\beta^2 \theta_0^2}}$$

	V(R) vs V(S)
Function	V(R)
<i>Selected Variable</i>	θ_0
<i>Discrete Variable</i>	β
<i>Continuous Variable</i>	V(S)

Table 2.4 Form of Variation Reliability Interaction Charts

This arrangement in the log-normal case is not in a viable form to solve for either V(R) or V(S). However, this function can be approximated using the Taylor Series expansion for a natural logarithm, or --

$$\beta = \frac{\ln \theta_0}{\sqrt{V_R^2 + V_S^2}} \rightarrow V(R)_{Log-Normal} = \sqrt{\frac{(\ln \theta_0)^2 - \beta^2 V_S^2}{\beta^2}}$$

2.2 Comparison Chart and Degrees of Conservatism

When is one random variable distribution better than another? When are results more conservative? Figures 2.1 through 2.4 demonstrate the shape of the distribution curves for the various forms of the reliability equation. Figure 2.5 highlights the comparison of the two distributions. For brevity, only one comparison is shown here; each of the others at Appendices A1.3, A2.3, A3.3, and A4.3 is similar. Figure 2.5 shows the Normal case is conservative ($\beta_N < \beta_{LN}$) from V(S)=0 to V(S)=0.13, then the Log-Normal case from V(S)=0.13 to V(S) = 0.5. A pattern appears for each graph type.

Distributions types may actually be very close numerically, and the engineer must find if the difference is significant. Table 2.5 lists the reliability index with its corresponding failure probability $[1-\Phi(\beta)]$.

Cumulative Normal Distribution: Failure Probability, $1 - \Phi(\beta)$									
β	0	1	1.5	2	2.5	3	4	5	6
P_f	0.500	0.159	0.067	0.023	0.006	0.001	$3 \cdot 10^{-5}$	$3 \cdot 10^{-7}$	$1 \cdot 10^{-9}$

Table 2.5 Failure Probability from Reliability Index

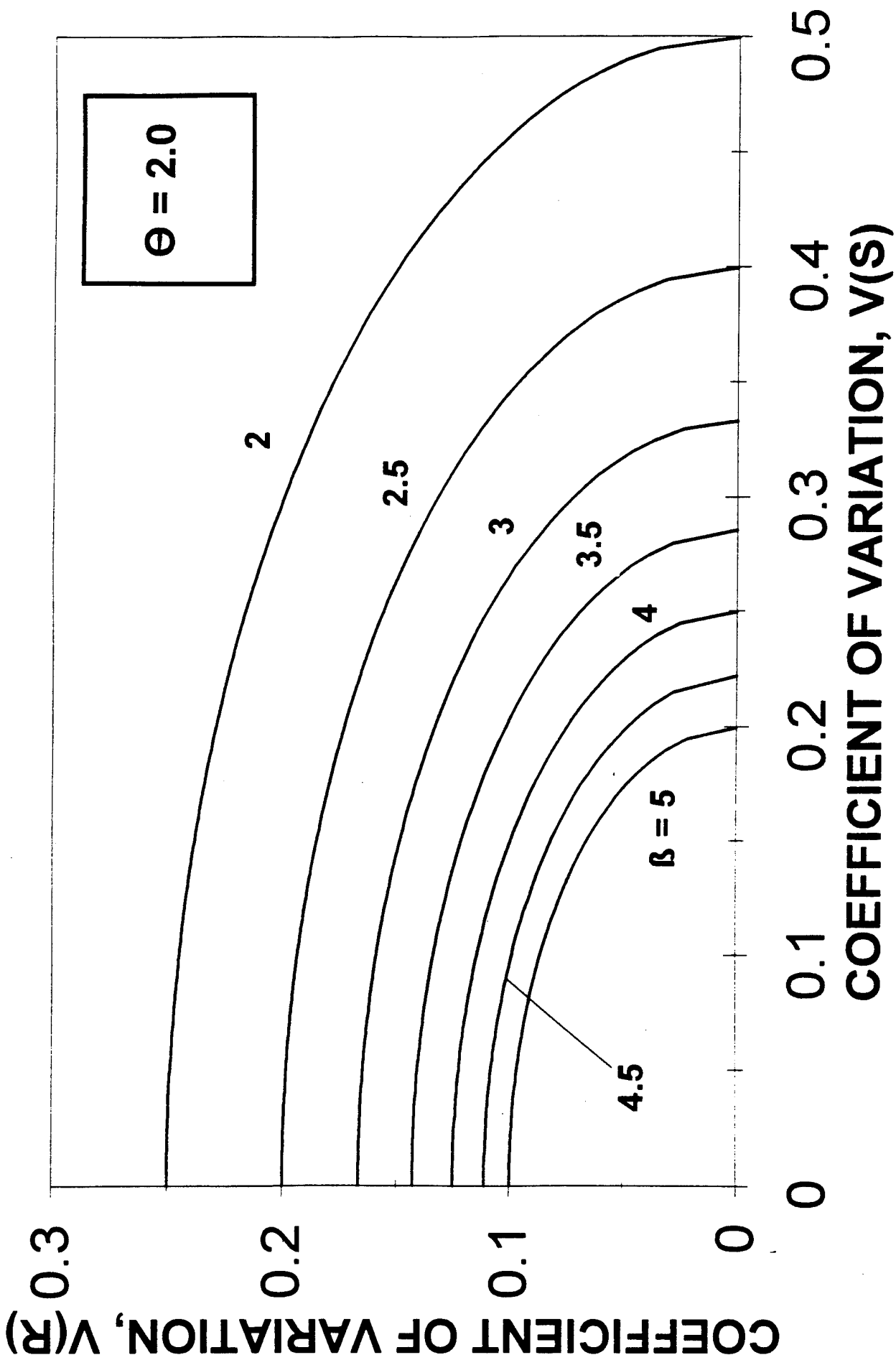

R: NORMAL, S: NORMAL

Figure 2.4

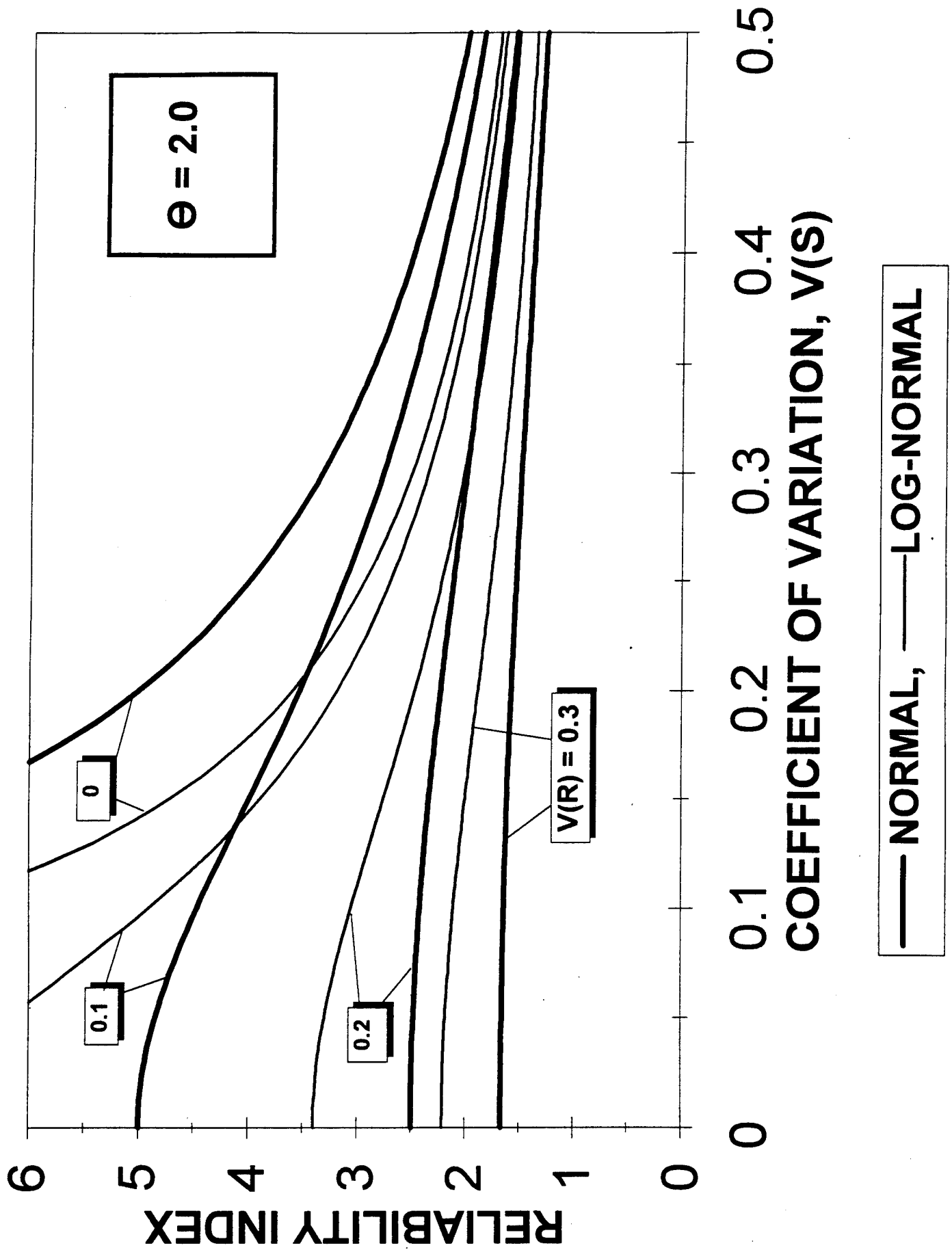

Figure 2.5

3.0 Beams under Random Loads

Two primary modes an engineer will check while conducting a design are the member's shear and moment. In general, a structural member will have several limit states (AISC LRFD, p. 2-6). Load conditions drive capacity requirement. Additionally, uncertainties in loads will either compound or counteract each other, depending on load correlation. In each example, load conditions were converted to mean shear and mean moment diagrams. The next logical step examines a method for converting uncertainty in load into shear and moment dispersion (variance) diagrams. The reliability of either mode is a function of both the mean and dispersion of the load effects.

The required reliability of an element (beam) depends in large part on its *importance* in a system. Moreover, what is the consequence to the system if an element fails? Importance is primarily a function of human risk of injury or death. Table 3.1 defines this reliability index as a function of the consequence and of the material behavior (Frangopol, p. 35).

Failure Consequence	Material Failure Mode	
	Ductile	Brittle
Less serious	2.5-3.0	3.0-3.5
Serious	3.0-3.5	>4.0

Table 3.1 Reliability Index Functional Requirements

The reliability equation encompasses parameters for materials properties, load effects, and the *relative distance* between the mean values of load and capacity. Reliability is greater for a beam with larger capacity, of course, but this *distance* can be specified--the *simple safety factor*. As will be shown, variance in load effects is directly quantifiable. In general, *randomness* in load dominates over the randomness in structural behavior (Borges, p. 163).

Six sample beam loading systems were selected and fully demonstrated. These are contained in Appendix B, and shown in Figure 3.1. Sample system 3, shown in Figure 3.1c, is further described in Sections 3.1 and 3.2. The beams were assumed uniform for the entire length. Thus, reliability has been computed for any point along the beam.

In each case, the reliability index for both shear and moment failure modes in the design step were calculated between $2\frac{1}{2}$ to 3. This level was selected to represent the *less serious* consequence in a ductile material. However, *brittle* and *ductile* also encompass the failure mode, more than a simple material property. Bending (moment) is a ductile failure mode; shear is more of a brittle failure mode. The above range is sufficient for bending, however the shear mode should have a reliability index of at least three for the same consequence.

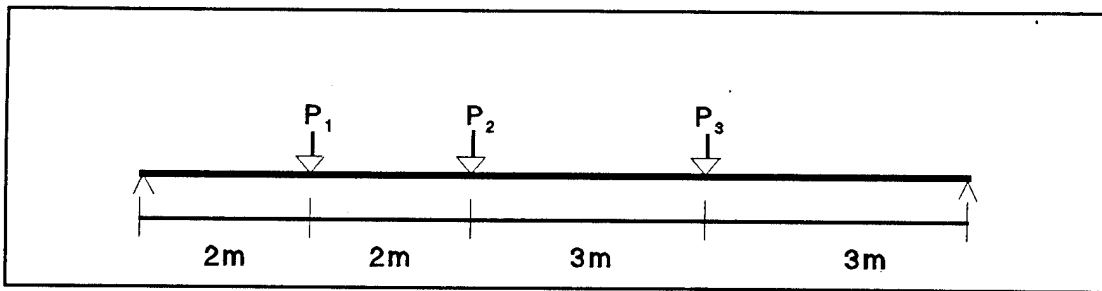

Figure 3.1a Simply Supported Beam (CVEN 5555)

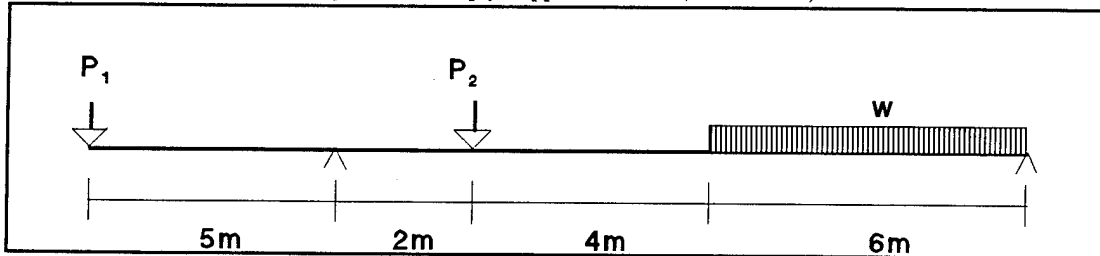

Figure 3.1b Simply Supported Beam, Cantilevered Left End (Laursen, p. 46, #2-8)

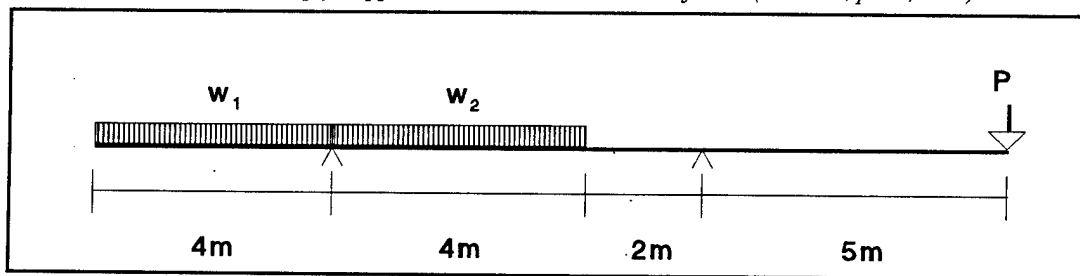

Figure 3.1c Simply Supported Beam, Double Cantilever (Laursen, p. 46, #2-7)

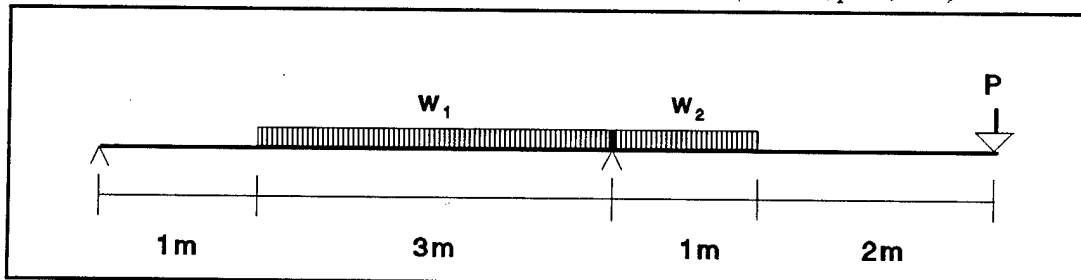

Figure 3.1d Simply Supported Beam, Cantilevered Right End (Laursen, p. 47, #2-9)

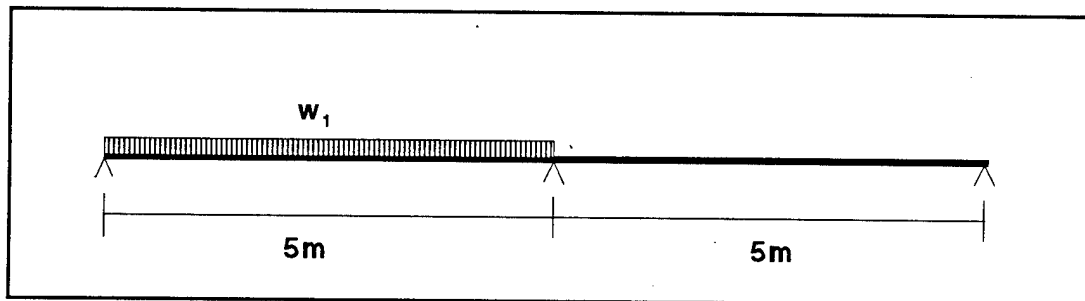

Figure 3.1e Indeterminate Beam [first degree] (AISC, p. 2-306, #29)

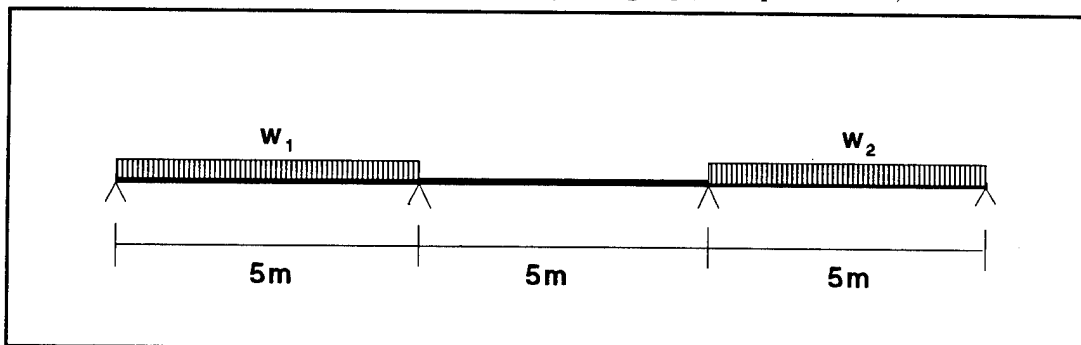

Figure 3.1f Indeterminate Beam [second degree] (AISC, p. 2-308, #35)

3.1 Reliability Analysis Step

This step was treated primarily as a familiarization phase, but it is also the first iteration step for attaining the required reliability. The beam shown at Figure 3.2 is sample system 3 (Appendix B3). The system was analyzed applying the load scheme in Table 3.2 against the modal resistances listed in Table 3.3.

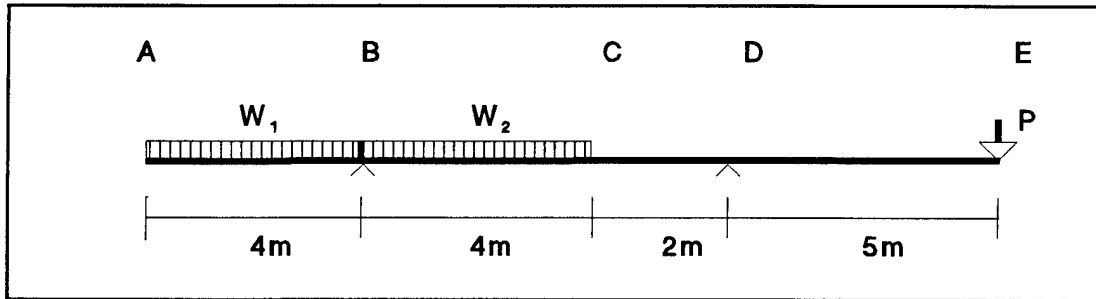

Figure 3.2 Beam under Random Load

Load	Mean	C.O.V.	Correlation Cases	i	ii	iii
w1 (kN-m)	2	6%	$\rho(w_1, w_2)$	0	1	1
w2 (kN-m)	2	12%	$\rho(w_1, P)$	0	0	1
P (kN)	10	10%	$\rho(w_2, P)$	0	0	1

Table 3.2 Beam Loads and Correlation

Mode	Mean	C.O.V.
Shear (kN)	20	10%
Moment (kN-m)	35	10%

Table 3.3 Beam Capacity

To fully analyze the load effects on a beam, the beam must be divided into segments with ends defined by a load or reaction point to compute the proper component for dispersion. This

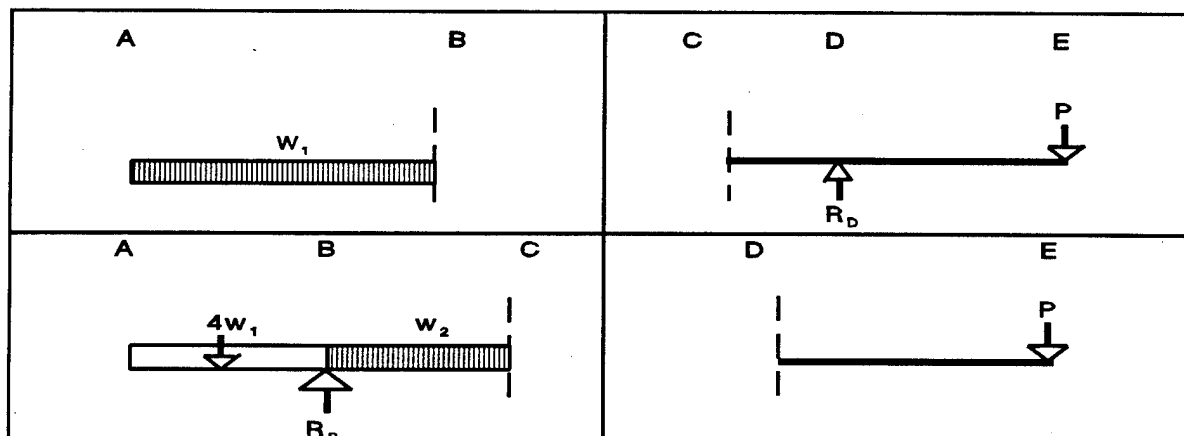

Figure 3.3 Segmented Beam under Random Loads

example is illustrated in Figure 3.3. All the examples at Appendix B were computed in this fashion. Locations of the loads are fixed for this analysis; uncertainty is associated with the load intensity. Comparing the load to resistance uses the straightforward form of the reliability index function: (load, load variance, capacity, and capacity uncertainty)

$$\beta = f(\bar{S}, \sigma_S^2, \bar{R}, V(R)).$$

This beam is separated into four segments: AB; BC; CD; and DE. Additionally, four equations exist for each segment. After calculating the reactions, the mean shear (\bar{S}_V), shear dispersion ($\sigma_{S(V)}^2$), mean moment (\bar{S}_M), and moment dispersion ($\sigma_{S(M)}^2$) are computed.

Each sample system included possible correlations between loads, either independently applied, partially correlated, or fully *coupled* loads. These cases were presented in Table 3.2. Correlation defines the bounds for expected answers in a system, since--

$$\rho^2 \leq 1$$

The first results are the mean shear and mean moment diagrams, Figures 3.4a and 3.4b. The dispersion diagrams are shown in Figures 3.5a and 3.5b. With these the load and variation can be defined at any point on the length of the member. Reliability is then calculated at each point, shown at Figures 3.6a and 3.6b (both R and S as normal variates). These diagrams reveal points of least reliability caused by the interaction of uncertainty, as well as the usual cases of maximum and minimum shear moment. Correlation did not effect the outcome of this example, The minimum reliability for this example is given at Table 3.4.

	min β	x (m)	Correlation
Shear (kN)	4.47	10 - 13	Case <i>i</i>
Moment (kN-m)	0.83	10.00	any case

Table 3.4 *Minimum Reliability Conditions*

Mean Shear Diagram

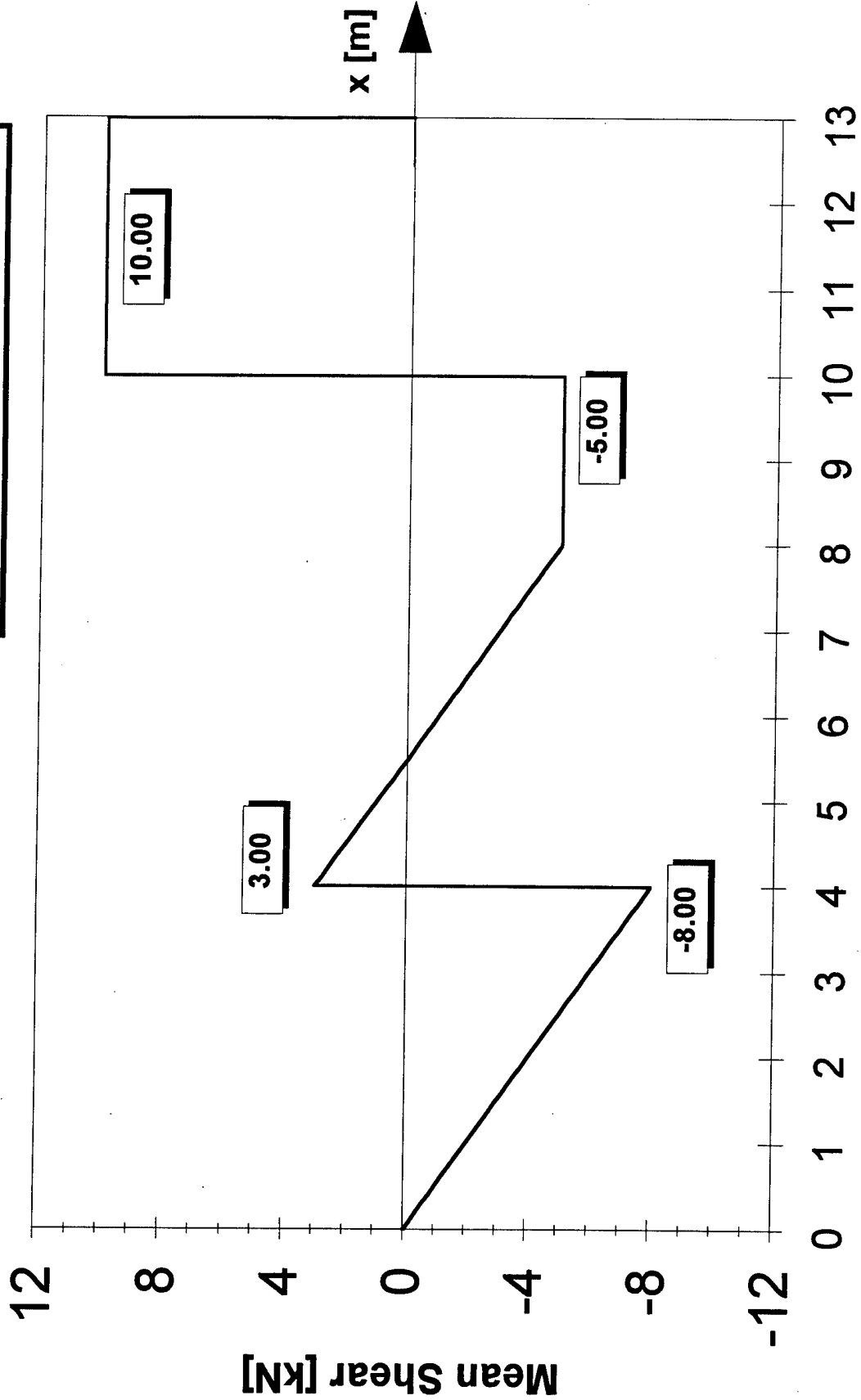

Figure 3.4a

Mean Moment Diagram

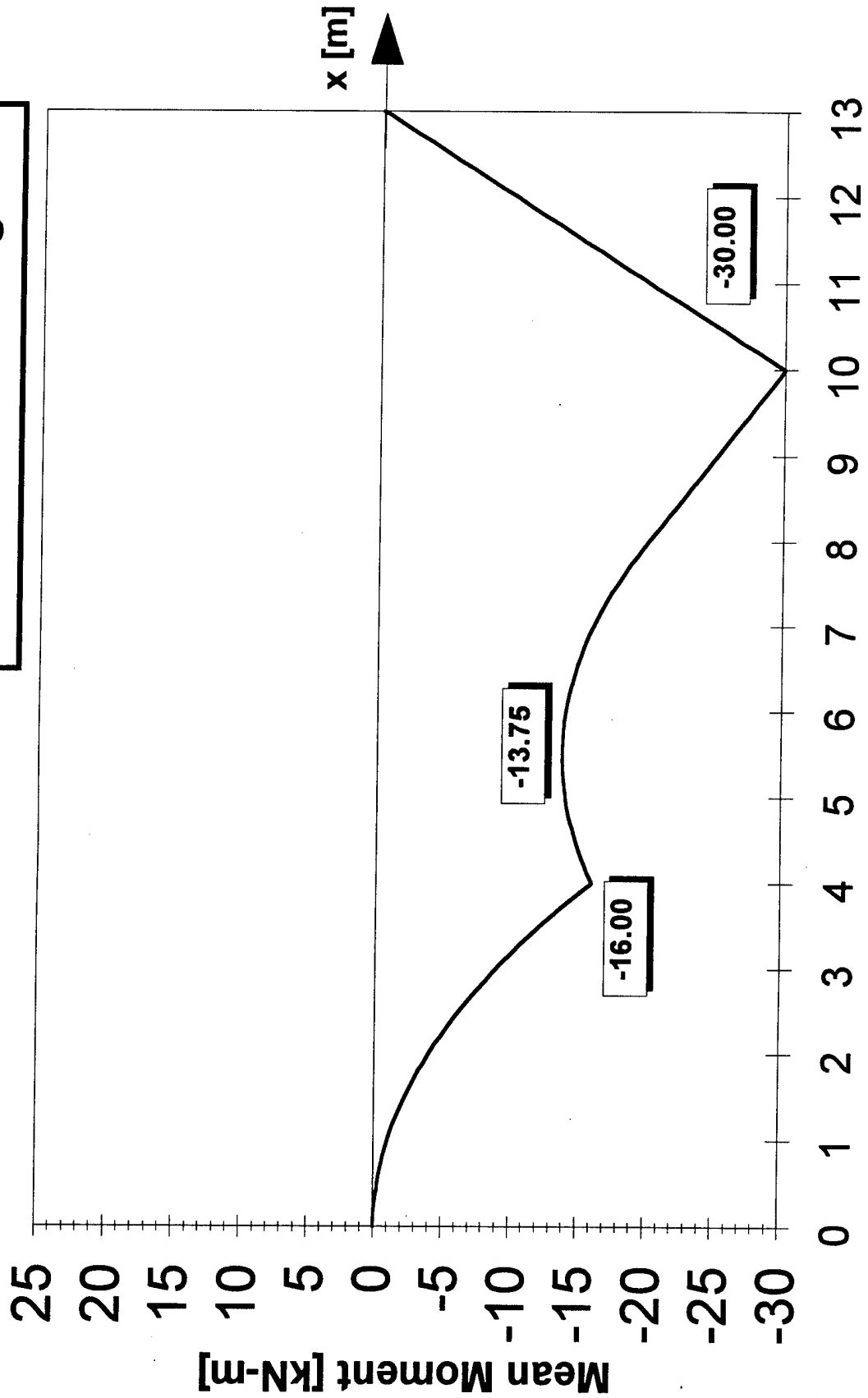

Figure 3.4b

Shear Dispersion Diagram

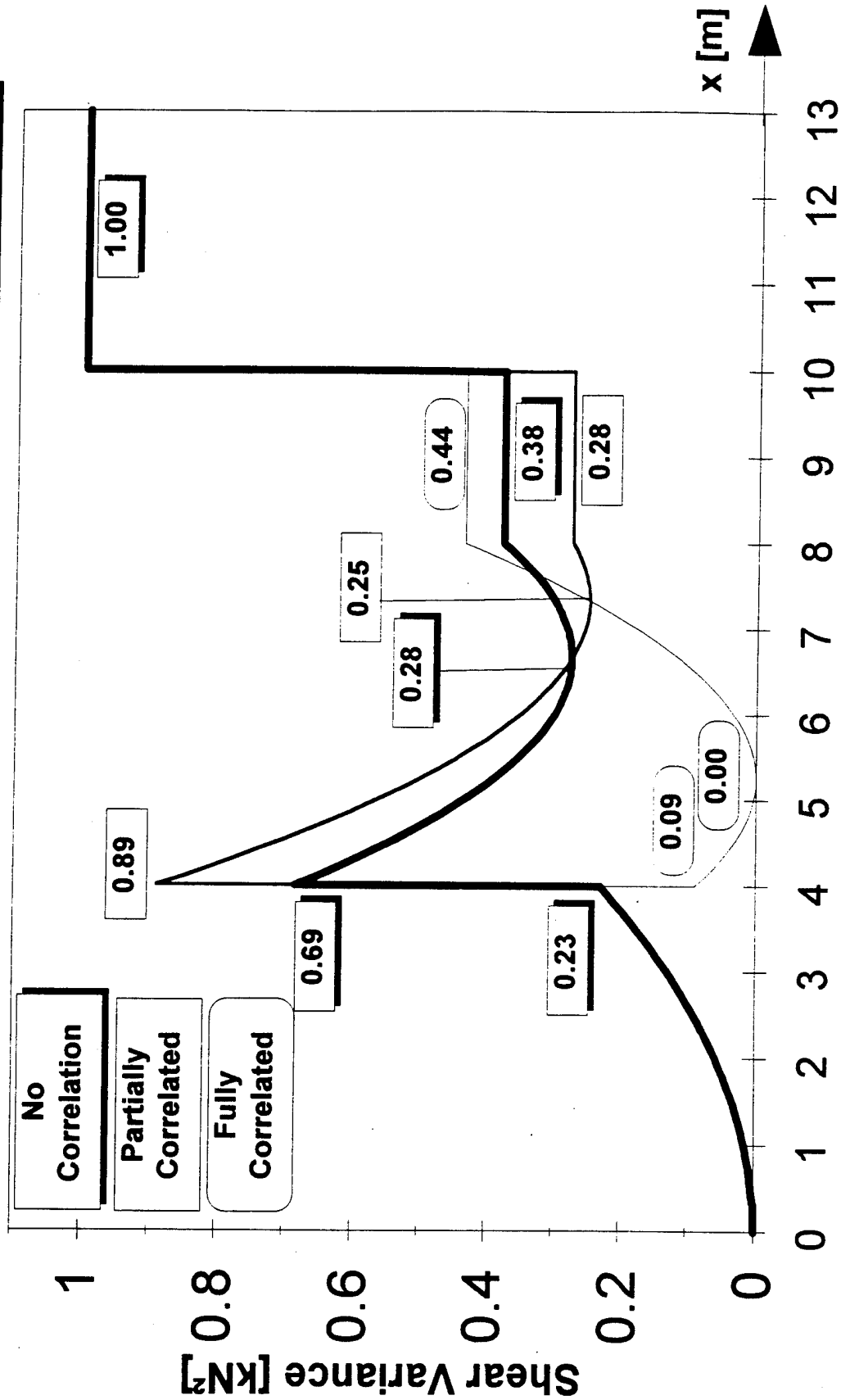

Figure 3.5a

Moment Dispersion Diagram

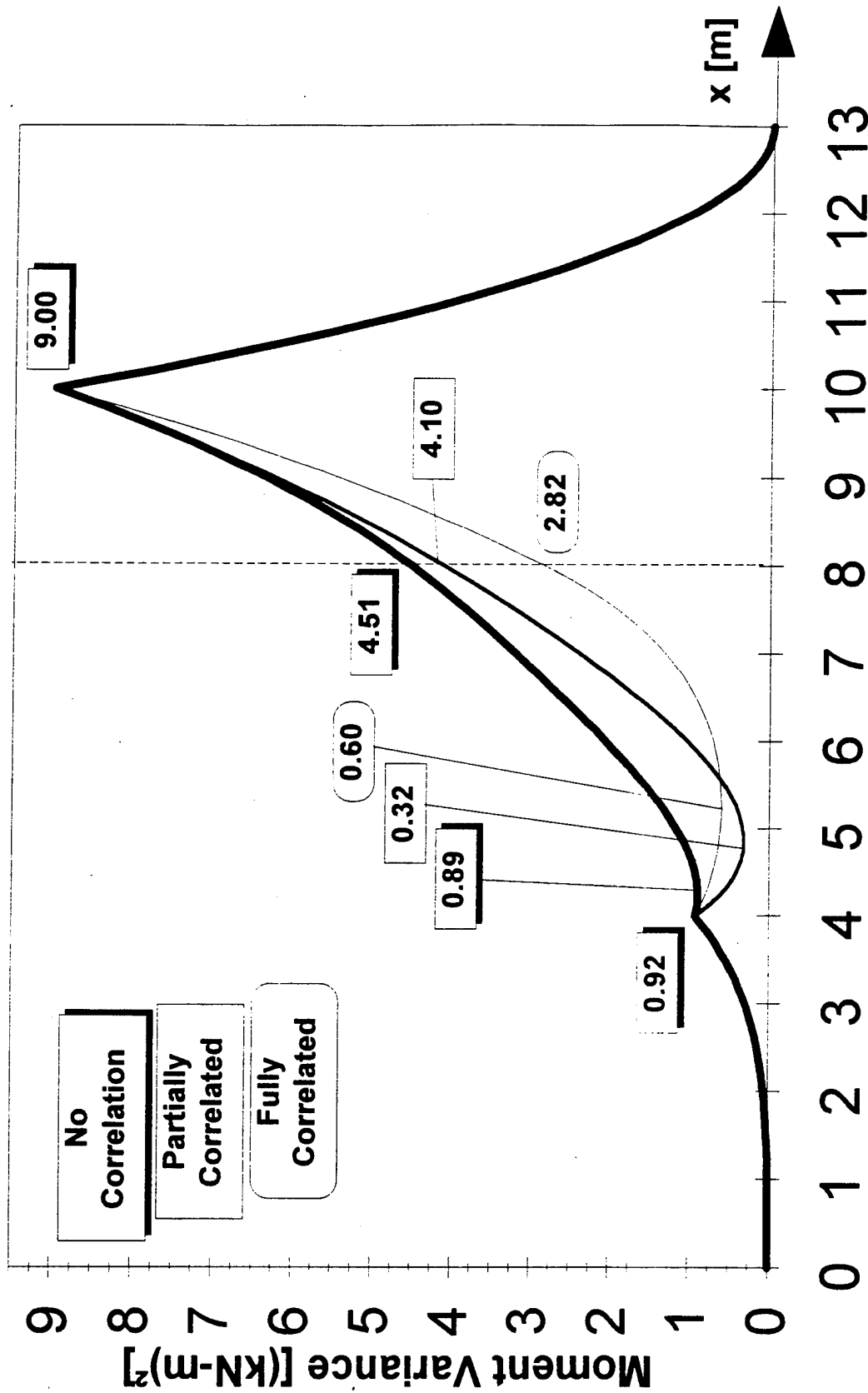

Figure 3.5b

3.2 Design Step

The results of the previous step indicated the example beam was very strong in shear capacity but weak in moment capacity. Selecting a sufficient beam capacity, a proper capacity relative to total load, is the focus of this step. From this, given actual load, a beam can be selected to meet this minimum requirement. Usual design procedure would require selecting a particular objective mode to design against failure, then verifying the design against the others, e.g., design for moment, then verify for shear, and vice versa.

For the work presented here a more appropriate arrangement of these five parameters would be--

$$\bar{R} = f(\bar{S}, \sigma_S^2, V(R), \beta_T)$$

This format allows the engineer to find the minimum capacity required for each mode. To target the required reliability, β_T , the method employs the *Reliability vs Safety Factor Interaction Charts*. Figure 3.8 details the chart for a calculated $V(S)$ and an approximate $V(R)$. This sample system incorporates an assumed value for $V(R)$. Using the $V(S)$ value for the minimum reliability point in the calibration step as the intersection line in Figure 3.7, the target reliability range yields an adjustment range for the central safety factor. Employing the conversion as--

$$\theta_0 = \left(\frac{\bar{R}}{\bar{S}} \right) \rightarrow \bar{R} = \left(\frac{\theta_0}{\bar{S}} \right)$$

Table 3.4 details the target adjustments for \bar{R} , applying the target reliability range: $2\frac{1}{2} < \beta < 3$.

	Lower Bound	Upper Bound	max \bar{S}	$V(S)$	θ_0	\bar{R}	
Shear (kN)	1.45	$< \theta_0 (N) <$	1.55	10	0.10	1.5	15
Moment (kN-m)	1.45	$< \theta_0 (N) <$	1.55	30	0.10	1.5	45

Table 3.4 Target Reliability Adjustment Ranges

The mean shear, shear dispersion, mean moment, and moment dispersion diagrams remain the same as before. Figure 3.8 demonstrates the adjusted reliability diagrams for the target index value. It is interesting to notice the values used for the central safety factor. Figure 3.9 illustrates how the safety factor varies over the whole beam.

Comparison and conclusions about these two concepts are discussed in Section 5.

Shear Reliability Diagram

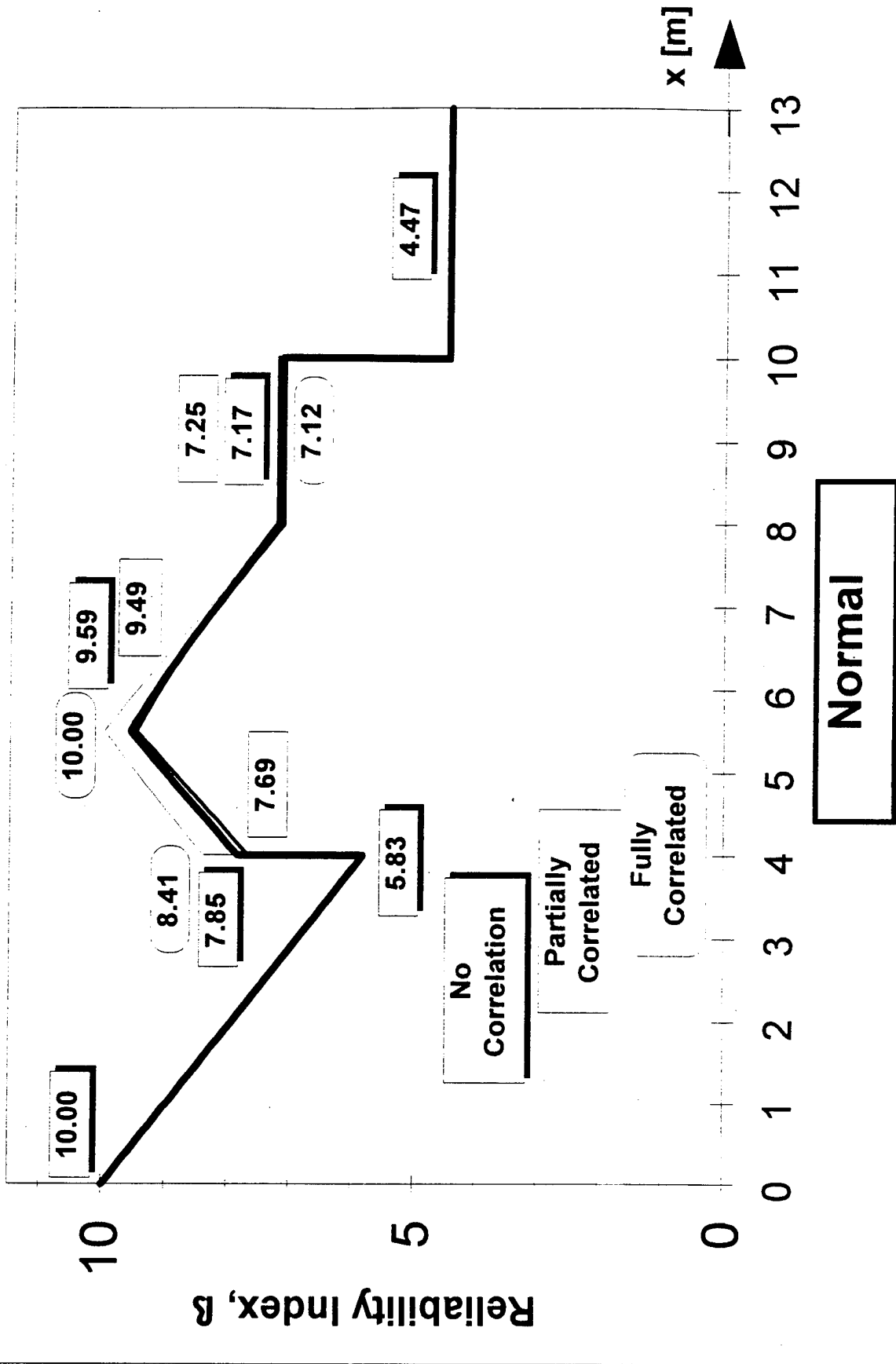

Figure 3.6a

Moment Reliability Diagram

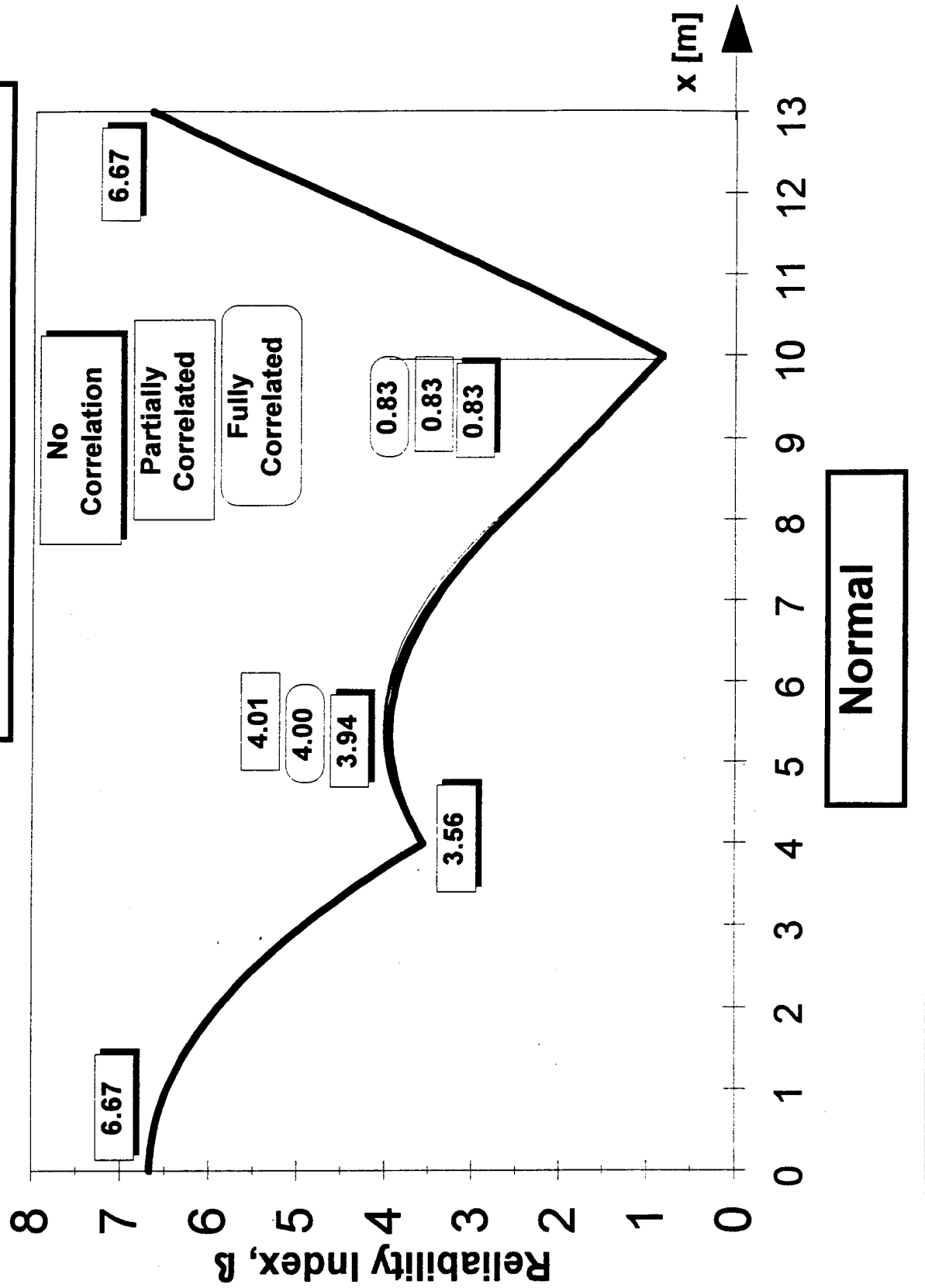
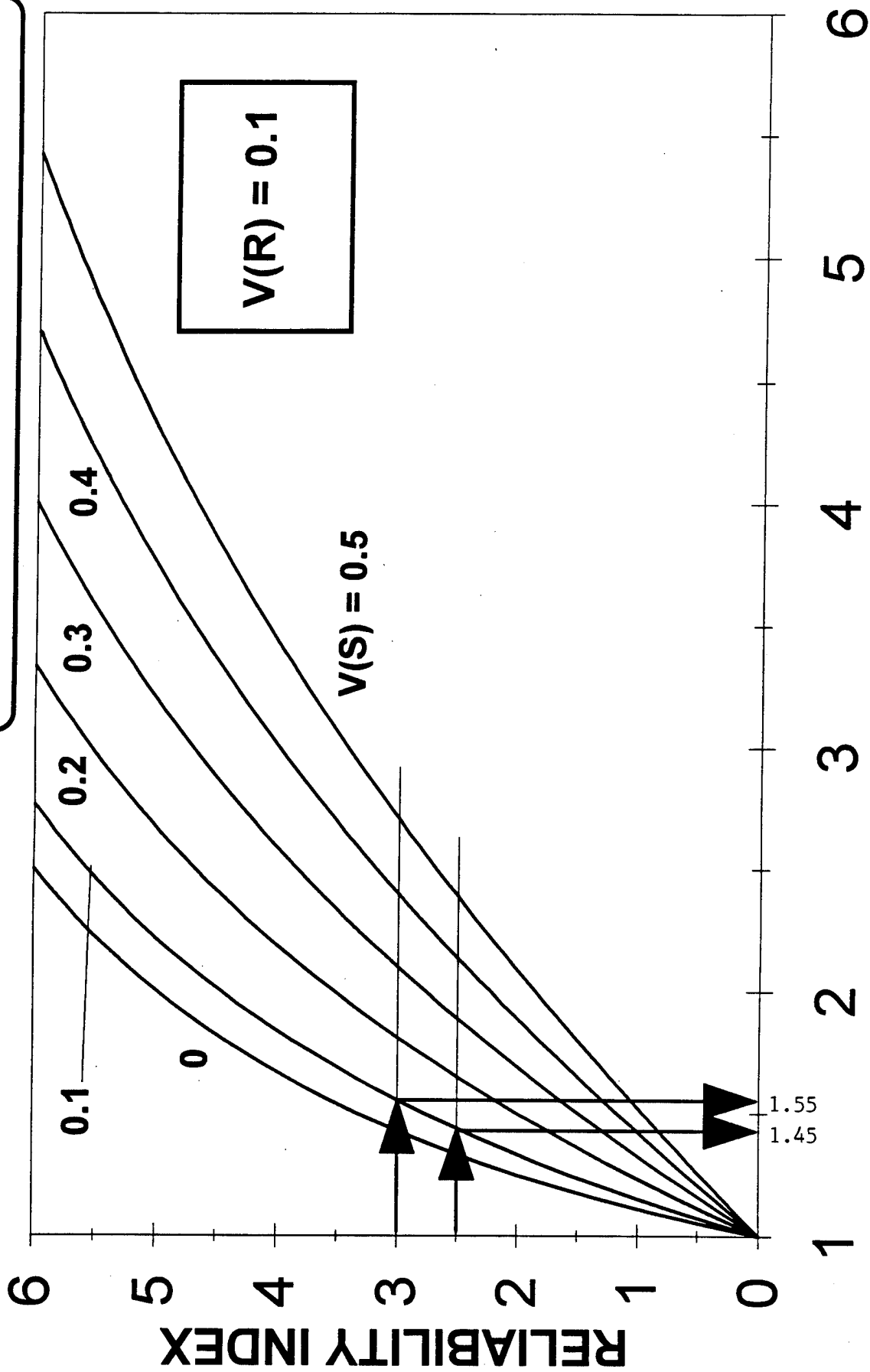

Figure 3.6b

Target Reliability



CENTRAL SAFETY FACTOR

R: NORMAL, S: NORMAL

Figure 3.7

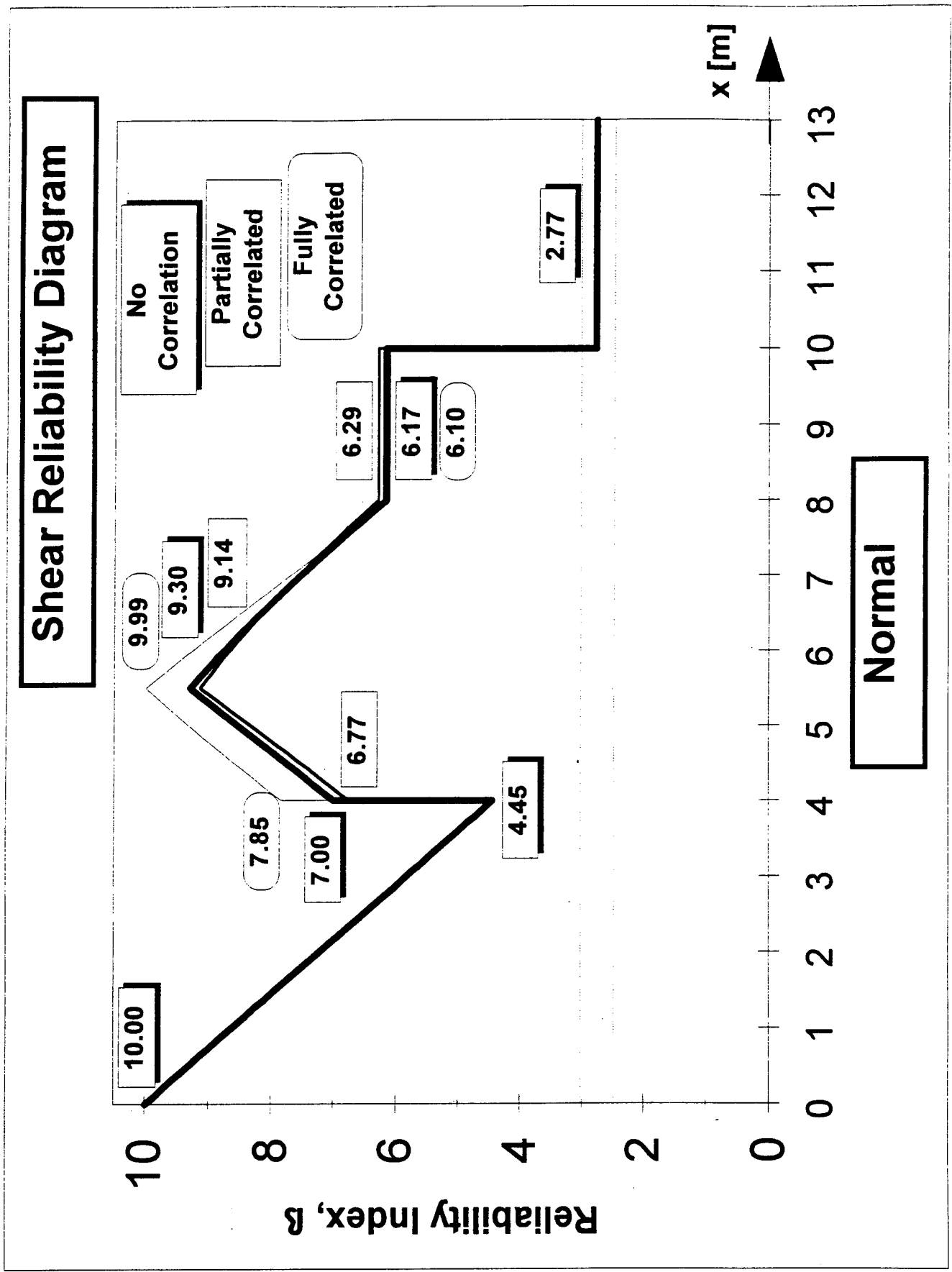

Figure 3.8a

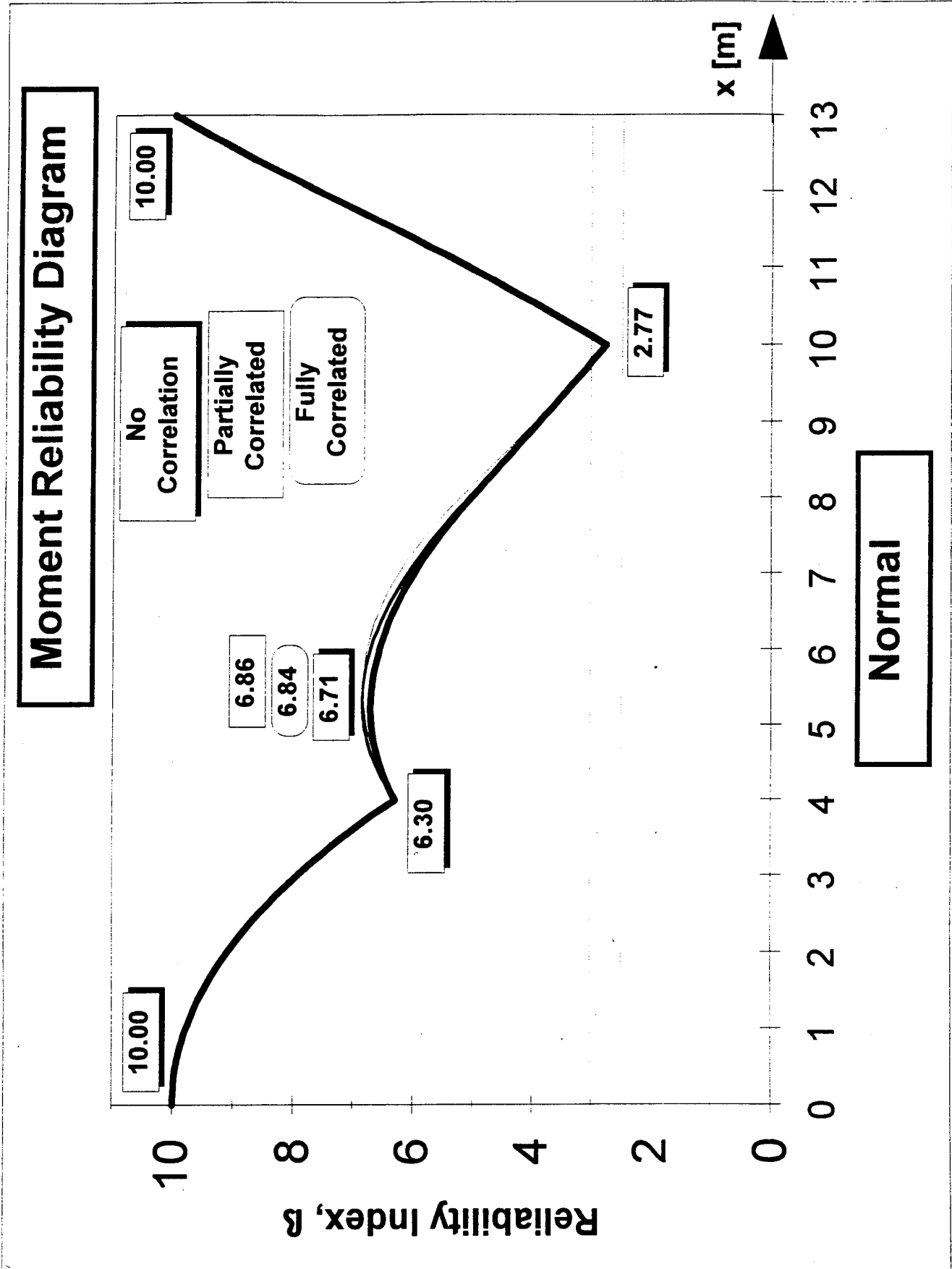

Figure 3.8b

Shear "Factor of Safety" Diagram

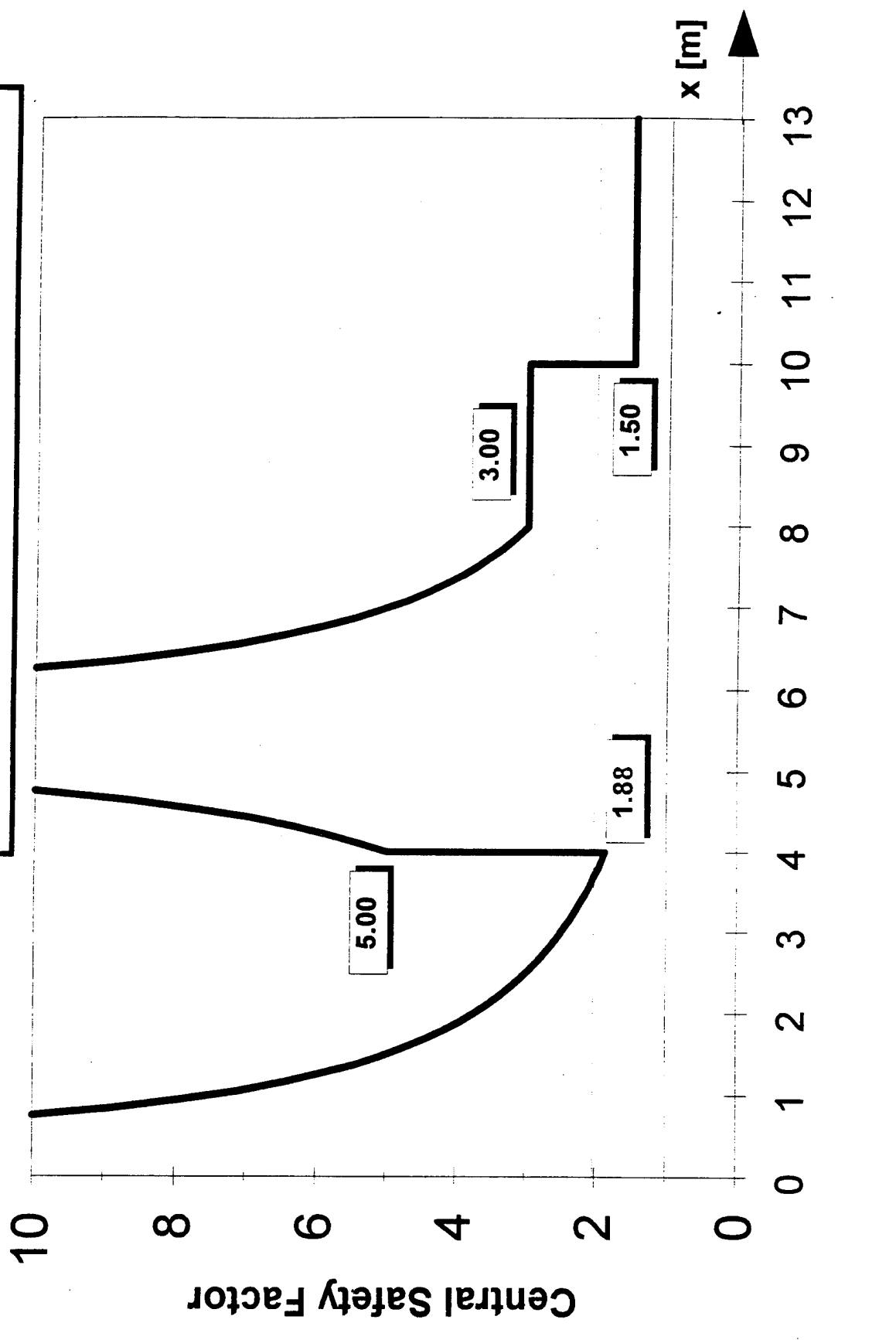

Figure 3.9a

Moment "Factor of Safety" Diagram

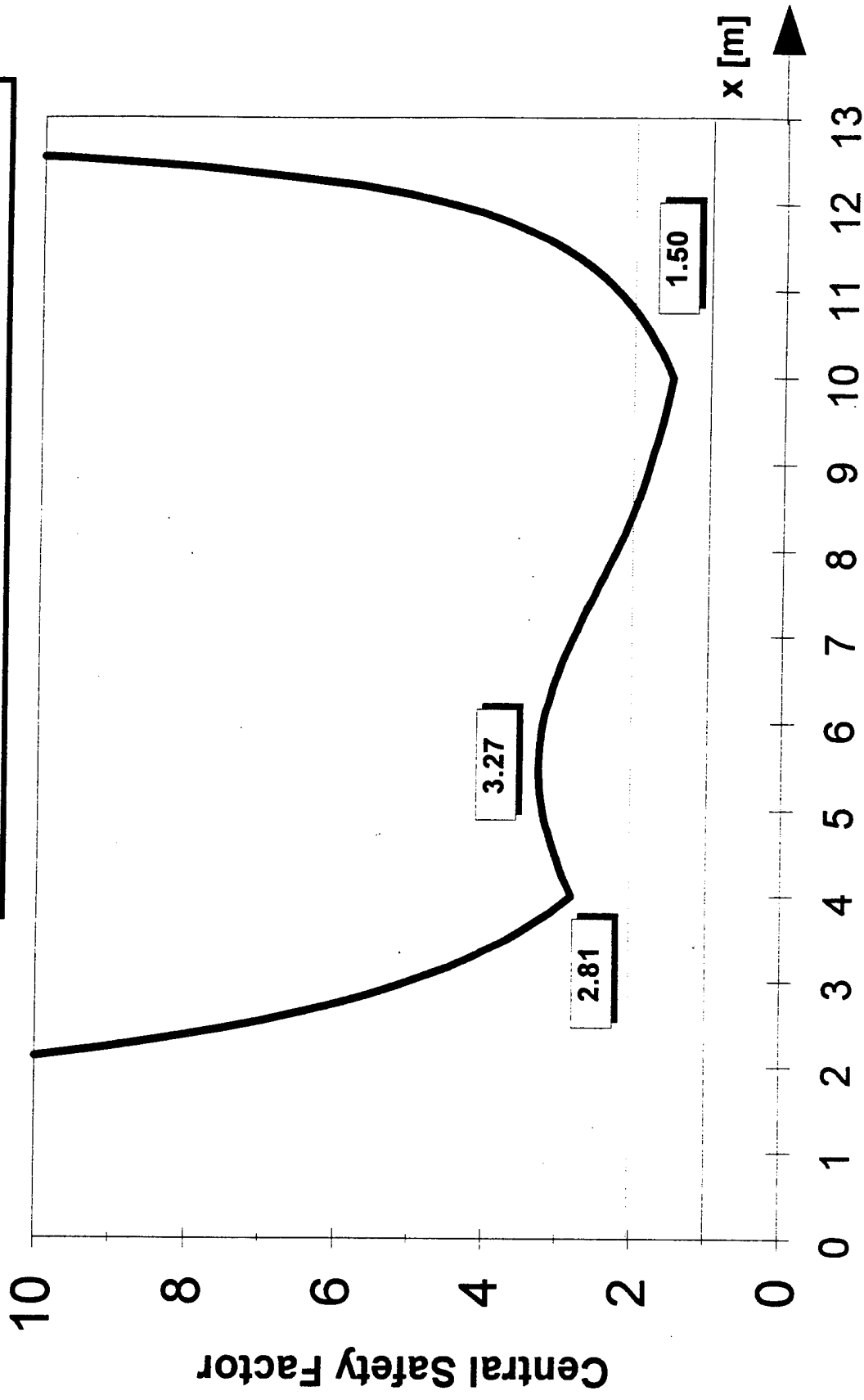

Figure 3.9b

4.0 Reliability Chart Applications

The following sub-sections present three applications. The first uses the perspective of a structural analyst to establish a reliability level for an element. The second is for the construction manager or project design engineer--to gain a valid perspective for reviewing a design. The third is for a damage analyst or inspector--to physically quantify the effect of damage on the reliability of a structure.

4.1 Structural Analysis Application

In an inspection program, the component members of a structure exist--sizes are known, material type is evident, actual loads are directly quantified along with the corresponding variance.

For example, one of the Air Force structural safety programs involves determining the condition of wood trusses in buildings. An engineer is required each spring and fall to visually review the condition of every wood truss structure on base. For the Project Manager on Lowry AFB, this involved inspecting approximately 45 buildings and about 10 work-days climbing through roofs.

In all, the result was one of two simple statements--approving the conditions as OK, or giving an order to fix a large crack. Beyond simple regard for a blatant problem, no reliability value could be calculated. To improve this situation, Figure 4.1 gives a direct quantity of reliability, as well as showing the maximum limit of reliability. Quantities that can be directly calculated (known) are mean load, load variance, member size, material uncertainty, and member capacity.

From this, reliability can be used to adjust the inspection program to save time and resources, and more importantly, provide a *real* measure for safety.

4.2 Design Review Application

In designing a structure, the engineer must have a keen eye for the final product. While this global view is important, equally important is the attention to detail--adequate design of every member and joint. As a simple design procedure, one could follow these steps using the charts:

- Verify load assembly [S_V , S_M]
- Calculate load uncertainty [$\sigma_{S(V)}$, $\sigma_{S(M)}$]
- Select target reliability level [β_T]
- Assume material and *design mode* uncertainty [$V(R)$]
- Find \bar{R}
- Find characteristics for load and resistance
- Check β
- Adjust/select \bar{R} ; calculate $\beta_{\text{limit state}}$ and β_{ult}

For resistance, use central values--select E and I, and assume V(R) for shear and moment. This method empirically mimics a more detailed probabilistic design (Kapur, p. 168) and as a first step, will provide initial resistance requirements. However, actual resistance figures require another step--all parameters must include their respective uncertainties. This approach was shown in the completion step for the beam systems--see Figure 3.7.

Structural Analysis

$\theta = 2.0$

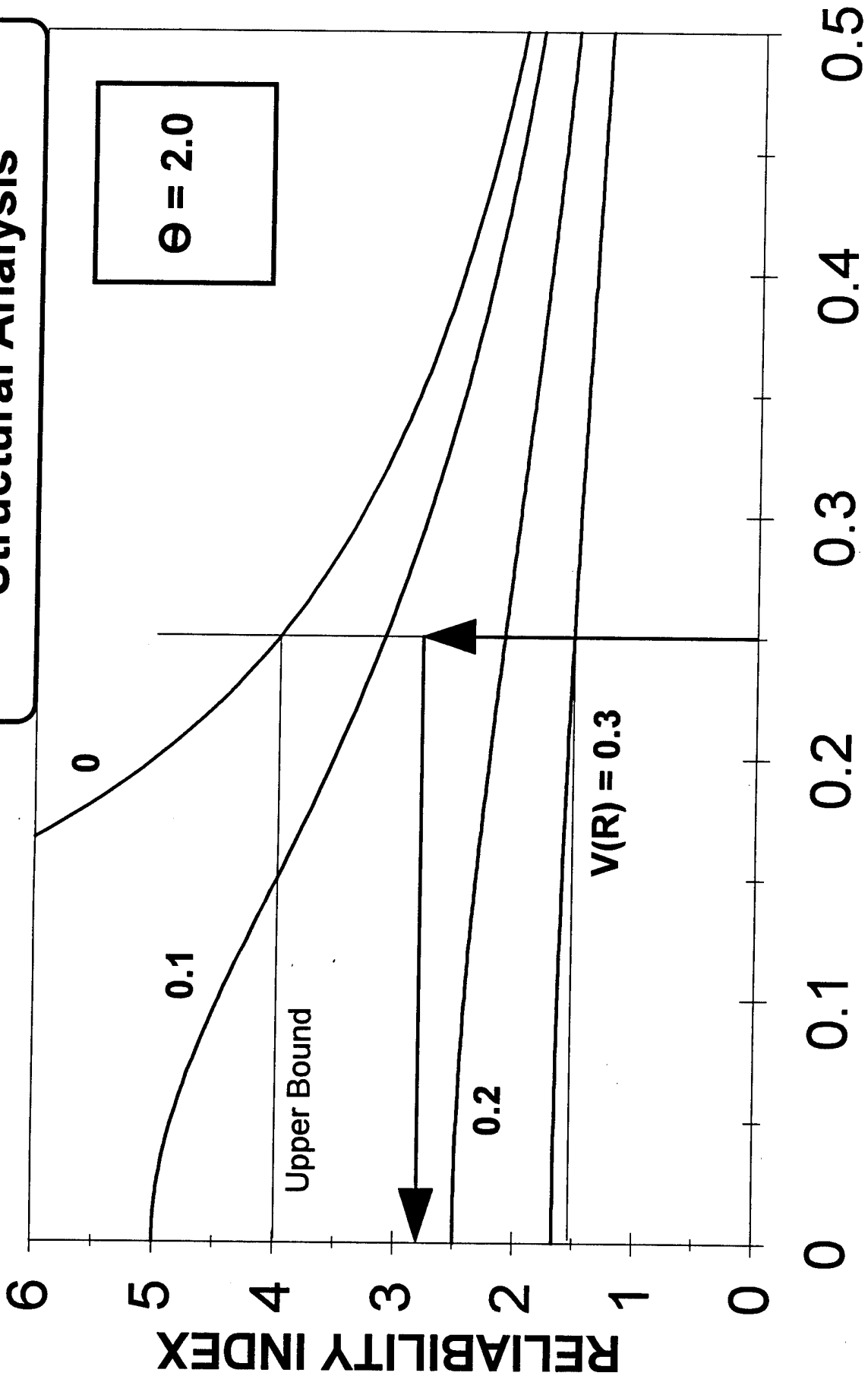

R: NORMAL, S: NORMAL

Figure 4.1

Additionally, the engineer needs to prevent an overdesign condition to minimize the facility cost to the owner. For a member in an assembly, if the selected material has a known uncertainty, and the loads and load variance have been quantified, what are the effects of overdesign? For example, consider two beams, each with their uncertainty as

$$V(R) = 10\%, \text{ and}$$

$$V(S) = 30\%,$$

with one beam of $\theta_0 = 2.0$, and the other $\theta_0 = 3.5$. Using the *Reliability vs Central Safety Factor: Interaction Chart*, at Figure 4.2 (also at Appendix A2.1), overdesign can reflect drastically in reliability.

For known uncertainty the range of these parameters varies as--

$$\theta_0 = \begin{pmatrix} 2.0 \\ 3.5 \end{pmatrix} \Rightarrow \beta = \begin{pmatrix} 2.9 \\ 5.4 \end{pmatrix}$$

In this case, a $SF \approx 3.5$ demonstrates a very high overdesign condition, much higher than the upper requisite defined at Table 3.1.

4.3 Damage Assessment Application

Another critical engineering function is damage assessment. What does a damaging event, such as a fire, do to a structure? Before and after an event, load remains constant, but capacity may decrease. Material uncertainty logically increases, thus reliability decreases from any pre-event value.

Figure 4.3 offers two perspectives for considering changes in resistance. Figure 4.3a

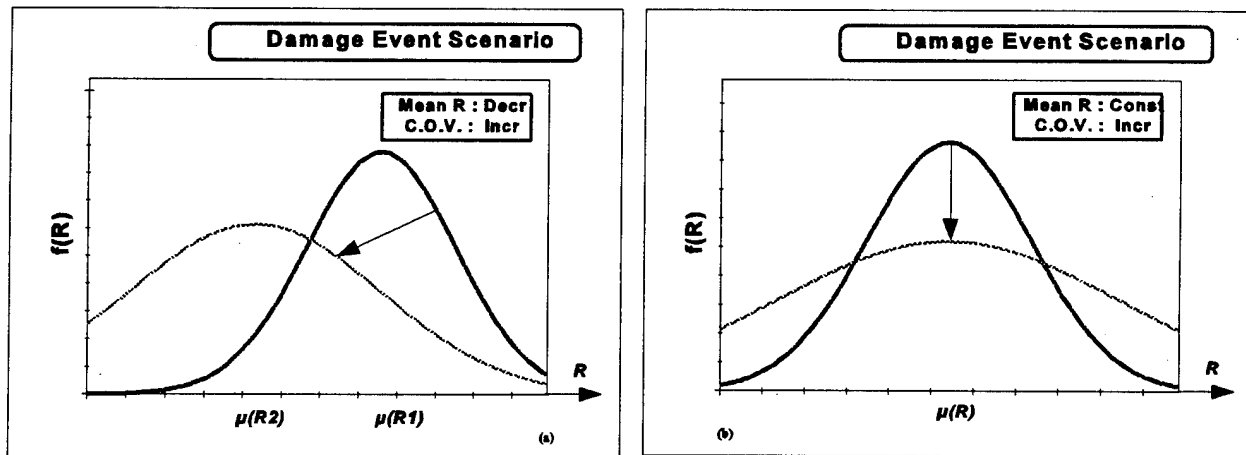

Figure 4.3 Uncertainty Changes in Damage Events

illustrates an decrease in mean resistance-- $\mu(R1)$ to $\mu(R2)$ --a decrease in θ_0 and an increase in uncertainty. This *usual* type of damage event is graphically described on the *Reliability vs Central Safety Factor: Interaction Chart* in Figure 4.4.

Figure 4.3b describes a milder damage event; the damage effect illustrated in Figure 4.5. This premise, for instance, may be indicative of a small, short fire. Uncertainty definitely does

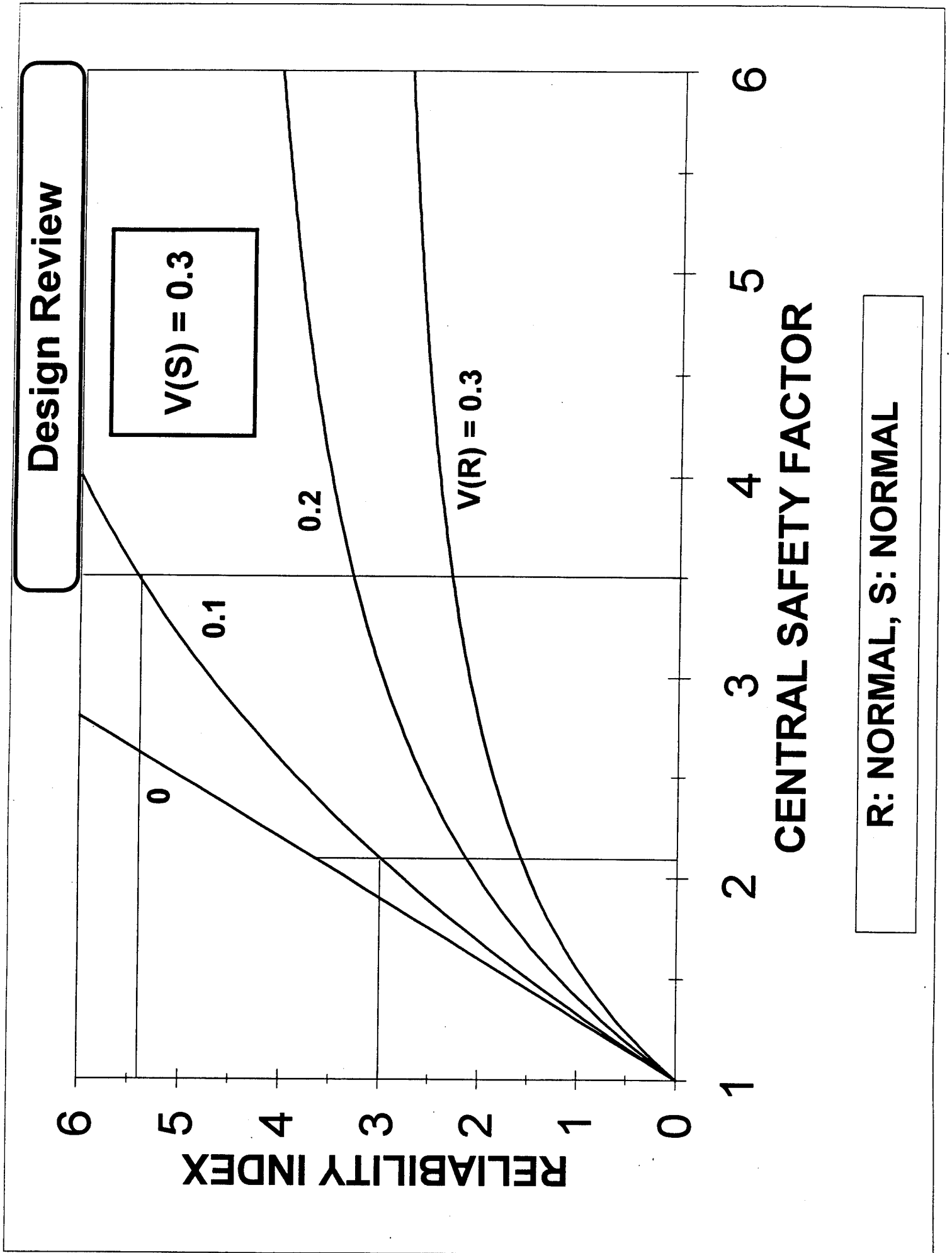

Figure 4.2

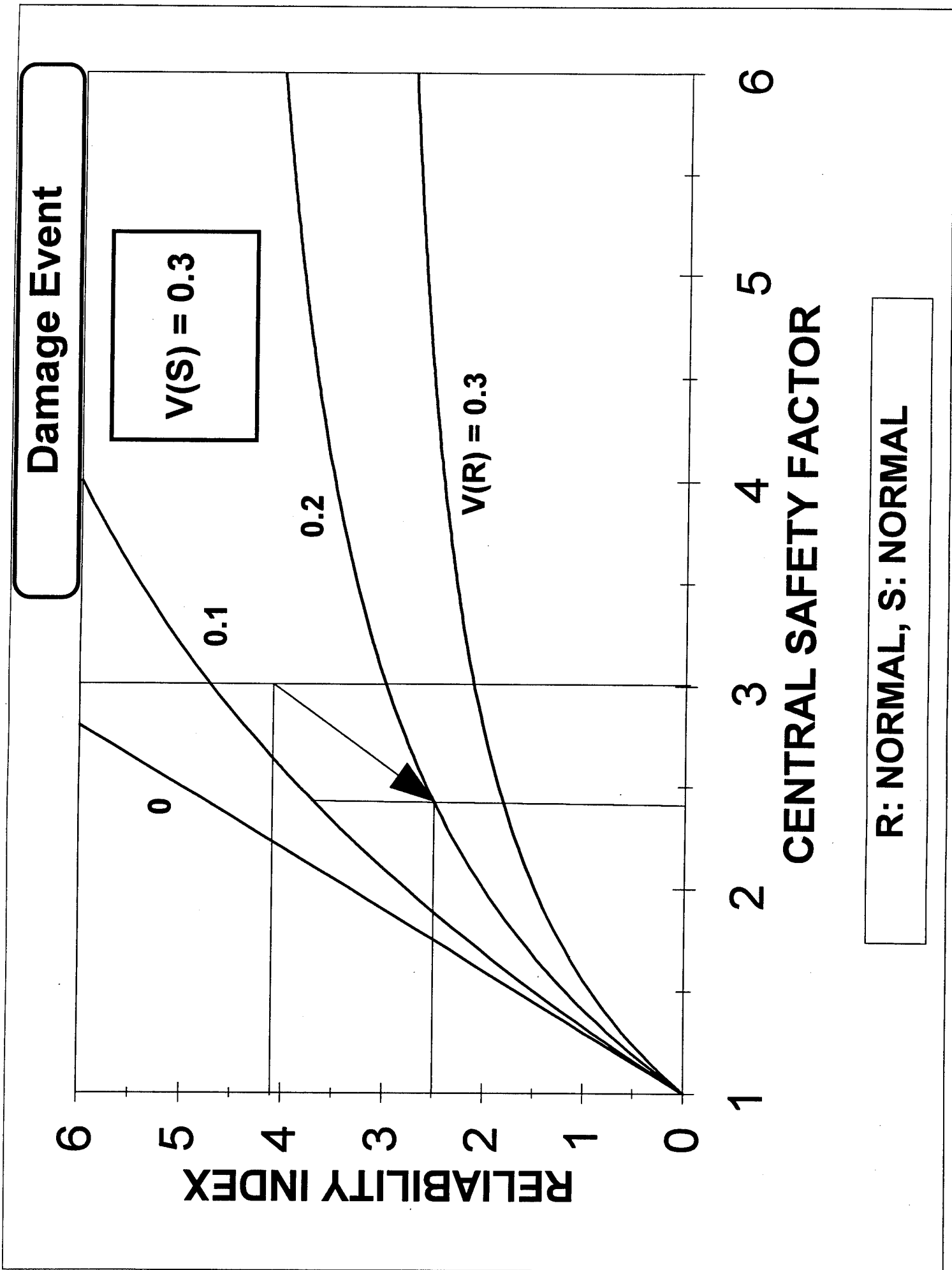
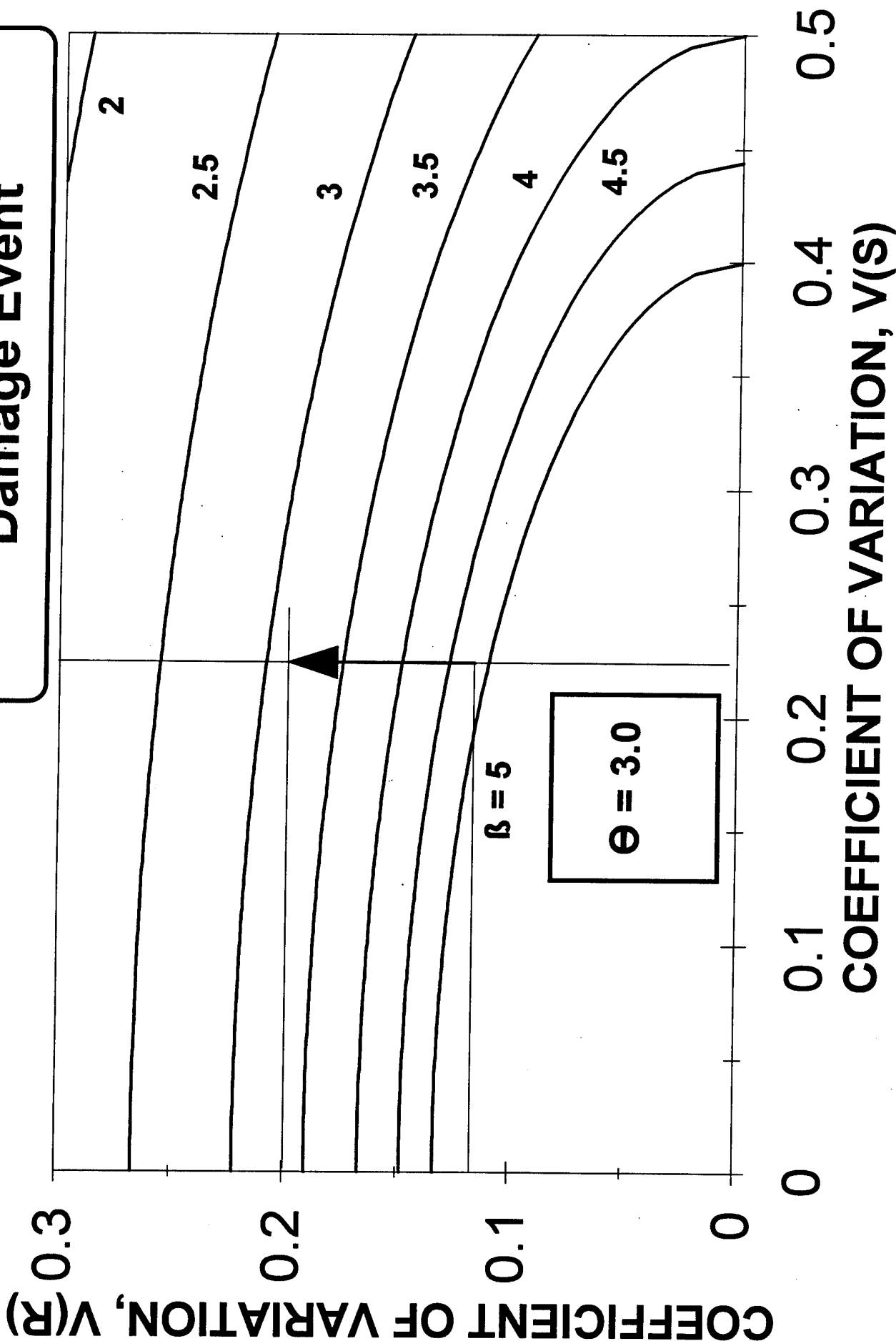

Figure 4.4

increase. The engineer could assume the mean value of capacity essentially remains the same after the event as prior-- θ_0 is constant, with a practical increase in capacity uncertainty. The result can be shown more explicitly on a *Coefficient of Variation: Reliability Interaction Chart*.

Damage Event



R: NORMAL, S: NORMAL

5.0 Conclusions for Probabilistic Improvements on Safety Factors

Reliability analysis is an improvement on the basic idea of a safety factor (SF). A young engineer may feel quite foolish designing a structure with a strength several times the theoretical requirement. However, it is widely known that safety factors are subject to many uncertainties, so much so that many engineers refer to the SF as a proverbial *factor of ignorance* (McCormac, p. 8). As illustrated before, much more is known about uncertainty in material and loading behavior. All of this can be incorporated into analysis, presenting charts and drawings like these at Appendices A and B to aid understanding. The engineer can now prove any requirement at each step of design.

5.1 Codified Design Discussion

A deterministic model has been a close approximation, and for a lack of *better information*, the safety factor has been a good value. However, better information demands a more refined model. A *good* approximation of load or material requires tight control on the actual values, meaning when the standard deviation is small, the variation is closer to zero. A *poorer* approximation has a larger variance. The deterministic model assumes no variance at all, it only inflates the *factor* to safely encompass all the unknowns. Is this factor of safety experience based? It is an estimate, a guess based on years of personal experience. It is a feeling the engineer uses to thoughtfully compile all the unknowns to *err on the side of safety*.

Three types of behavior ranges are presently used in codified design--elastic conditions, elasto-plastic (post-elastic) conditions, and ultimate conditions. Of the three types, *which type is best* is a source of considerable debate. Numerous authors and practitioners espouse the reliance on material strength beyond the yield point. Other factors beyond simple load resistance (e.g., earthquake structural response), make these strength considerations necessary.

The first approach is deterministic analysis limited to elastic behavior--Allowable Stress Design (ASD). Elastic behavior is the easiest concept to quantify, the mathematics are generally linear and easy to manipulate. Theoretically, if loads do not stress a member beyond its yield point (constant loads, without cyclic or creep loads), the system should last indefinitely. Lab tests have defined material yield and ultimate loads. However, what happens in between is neither linear nor precise.

Another approach centers on ultimate stress design (USD). This is the title of the concrete American Concrete Institute code. The steel industry, American Institute of Steel Construction (AISC), uses the Load and Resistance Factor Design (LRFD). This methodology quantifies the material behavior between the limit states. A further extension of these is Probability-Based Limit State Design (PBLSD) approach, the basis for the methods presented in Section 3.

LRFD's primary objective for AISC is to provide a uniform reliability for steel structures under various load conditions. With AISC's ASD, this uniform approach cannot be obtained (Manual for Steel Construction LRFD, p. 2-5). The AISC load factors are based on research completed by the American National Standards Institute (ANSI) (*ibid*, p. 2-6).

ASD limits were set by years of observance and corrected learning from disasters. ASD failure is defined as $f_s > f_n$, so to keep working stresses beneath the defined allowable, this method applies a safety factor to a nominal strength:

$$\left[f_s = \sum q_i \right] < \left[f_a = \frac{R_n}{SF} \right]$$

The safety factor can be a simple ratio to relate the two, or can be an elaborate function.

When the analyst encounters an overload condition, the allowable load approach provides no feeling for systems safety, i.e. what additional load would produce a catastrophic disaster? An overload is beyond the ASD failure definition, but the structure is still intact. The engineer must use a method that accounts for this, an analysis that proportions structures so no limit state is exceeded (ibid, p. 2-6).

Loads, as well as resistances, may act independently, or correlated. There is a need to amplify or reduce the respective loads, as well as reduce the maximum resistance to an acceptable, safe level. This approach is the basis for the ACI (USD) code and AISC (LRFD) code. The LRFD uses separate factors for each load and each modal resistance, summarized in the form--

$$\left[f_s = \sum \gamma_i q_i \right] \leq \left[f_{limit\ state} = \phi R_n \right]$$

Any model must include considerations for both load and material effects. This is the essence of PBLSD, fully a behavior-oriented design method meeting the requirements for function at service loads and safety at extreme loads (Frangopol, p. 27). This form was described in Section 2.0. Each limit state has an associated nominal strength defining the boundaries of structural usefulness.

5.2 Probabilistic Improvements Summary

Precision in analysis is rooted in understanding. The sample load systems and the interaction charts provide a visualization of the thoughts behind codified design. For many cases, higher order analysis is needed for complete design. The design process is a dynamic interaction of engineers, architects, and inspectors, as well as the owner. The first steps in design are two-fold--organize the design and plan the design effort.

The basis behind the probabilistic model validates the whole idea. The model contrives an idealized curve, relying upon historical data--an experience-based numerical method. For a desired type of event, the occurrence of the event is repeatedly tested and the frequency of the results tabulated. This histogram defines the event's idealized curve using the form of the probabilistic model.

To effectively generate a probabilistic model, for example, about the expected life of the new asphalt pavement, the engineer would need the compiled data of many similar designs and life cycle of constructed projects. This probabilistic model would be a function of the correlation of several parameters, e.g., pavement thickness, local environment, use, construction quality. An illustration would rely on several years of observance and project data. The histogram describes a behavior pattern; a probabilistic mathematical model can be fit to mimic the data.

Ultimately, the histogram becomes a decision model. A picture develops of the expected *actual* expected life and defines bounds rather than a notional *stab* based on the design life.

Additionally, a case study like this can be expanded to identify condition ranges (i.e. good, fair, poor) from the life expectancy, as well as a model to decide if that early failure was a result of material failure or construction quality. Associated probabilities can be calculated as simple components and give regard to any conditional probabilities. Consider the following framework:

T \equiv pavement thickness
E_A \equiv desert (arid) environment
E_{MT} \equiv temperate environment (moderate freeze/thaw activity zone)
E_{ST} \equiv temperate environment (severe freeze/thaw activity zone)
Q \equiv construction quality

Then P(T), P(E_A), P(E_{MT}), P(E_{ST}), and P(Q) define the probability of failure of the subject road section associated with each parameter. Additionally, with the calculation the conditional probabilities, such a P(T/E_A), P(T/E_{MT}), P(T/E_{ST}), P(T/Q), etc., the situation is definable as a probabilistic model.

Another probability application involves value ranges for loads. With a deterministic viewpoint, the engineer would pick one value. But from a probabilistic viewpoint, what makes that value any better than any other? The snow load, as an example, for a given year could just as easily be the high value or low value. Instead of selecting one value, why not select all? If the engineer assumes a normal distribution, the central value could be the mean, and the range four standard deviations (86.6% of the expected values). The design snow load for the Denver, Colorado, area--taken from the *American National Standards* (ANSI) A58.1-1982-- are 15 lbs/ft² to 25 psf. The parameters in ANSI are based on years of reported data; this fits the basis for the probabilistic model. If normal, the central value, 20 psf, becomes the mean and the range, 10 psf, is 4σ , or $V(S) = 12.5\%$.

There is a fair amount of friction among engineers about the usefulness of reliability-based analysis. To quote *Civil Engineering* magazine,

LRFD affords the designer the flexibility to make knowledgeable decisions through a more advanced and rational design approach.

Most engineers recoil from reliability-based design for at least two reasons--complexity and cost.

The *Reliability Interaction Charts* and the sample beam discussion presented in this report provide a visualization of the Probability-Based Limit State Design (PBLSD) procedure. The results presented alleviate the engineer's fears of probabilistic mechanics. This will become easier for engineers when they realize they already use this type of code in the ACI Ultimate Strength Design (USD) code (ACI-318).

Resources

- Ang, A. H-S., and W.H. Tang, ***Probability Concepts in Engineering Planning and Design, Volume I--Basic Principles, Volume II--Advanced Concepts and Applications***, John Wiley and Sons, New York NY, 1975.
- Blându, M., and J. Hammel, ***Wind, Snow, and Temperature Effects on Structures Based on Probability, English Edition***, Abacus Press, Kent, England, 1975.
- Borges, J.F., and M. Castanheta, ***Structural Safety, Course 101, Second Edition***, Laboratório Nacional De Engenharia Civil, Lisbon, Portugal, 1971.
- Building Code Requirements for Reinforced Concrete (ACI 318-89) and Commentary (ACI 318R-89)**, *American Concrete Institute*, Detroit MI, 1989.
- Carter, C.J., and I.M. Alsamsam, "From ASD to LRFD: The Time is Now", ***Civil Engineering Magazine***, American Society of Civil Engineers, New York NY, February 1985.
- Cornell, C. Allin, ***A Probability-Based Structural Code (Fourth in Series)***, ***ACI Journal***, American Concrete Institute, Skokie IL, December 1969.
- Dai, S-H, and Wang, M-O, ***Reliability Analysis in Engineering Applications***, Van Nostrand Reinhold, New York NY, 1992.
- Frangopol, Dan M., ***Basic Structural Design: Part 1, Basic Concepts in Structural Design***, University of Colorado, Boulder CO, 1985.
- Grinter, Linton E., ***Elementary Structural Analysis and Design: Steel, Timber, and Reinforced Concrete, Second Edition***, MacMillan Company, New York NY, 1965.
- Kapur, K.C., and Lamberson, L.R., ***Reliability in Engineering Design***, John Wiley & Sons, New York NY, 1977.
- Kornhauser, M., ***Structural Effects of Impact***, Spartan Books Inc., Baltimore, Maryland, 1964.
- Laursen, Harold I., ***Structural Analysis, Third Edition***, McGraw Hill, Inc., New York NY, 1988.
- Manual of Steel Construction, ASD**, Ninth Edition, and ***LRFD***, Second Edition ***American Institute of Steel Construction, Inc.***, Chicago IL, 1989, 1994.

McCormac, J., ***Structural Analysis: A Classical and Matrix Approach***, Harper & Row Publishers, 1988.

McCormac, J., ***Structural Steel Design***, 3rd Ed., Harper & Row Publishers, 1981.

Minimum Design Loads for Buildings and Other Structures, *American National Standards Institute*, New York NY, 1982.

Moses, Fred, *Reliability of Structural Systems*, ***Journal of the Structural Division***, American Society of Civil Engineers, New York NY, September 1974.

Nakib, R., ***Reliability-Based Analysis and Optimization of Ductile Structural Systems*** (*M.S. Thesis*), University of Colorado, Boulder CO, 1985.

Reliability Index versus Safety Factor of Structures

Appendix A

Cases

Normal Variates → Ax.1-x
Log-Normal Variates → Ax.2-x
Comparison of Variates → Ax.3-x

Types

Reliability vs V(R), V(S) Interaction Charts → A1.x-x
Reliability vs Central Safety Factor Interaction Charts → A2.x-x
Central Safety Factor vs V(R), V(S) Interaction Charts → A3.x-x
V(R) vs V(S) Reliability Interaction Charts → A4.x-x

Appendix A A1

Reliability Interaction Charts *Design for Reliability Index*

	β vs V(S)	β vs V(R)
Function	β	β
<i>Selected Variable</i>	Θ ₀	Θ ₀
<i>Discrete Variable</i>	V(R)	V(S)
<i>Continuous Variable</i>	V(S)	V(R)

Cases

Normal Variates A1.1-1 → A1.1-14
Log-Normal Variates A1.2-1 → A1.2-14
Comparison of Variates. A1.3-1 → A1.3-14

Function	0 ≤ β ≤ 6	all charts
<i>Variables</i> Select each Θ ₀ Display all V(R), V(S)	Θ ₀ : 1.1, 1.5, 2, 3, 4, 5, 6 V(R): 0, 0.1, 0.2, 0.3 0 ≤ V(S) ≤ 0.5	both cases <i>β vs V(S) type</i>
Select each Θ ₀ Display all V(R), V(S)	Θ ₀ : 1.1, 1.5, 2, 3, 4, 5, 6 V(S): 0, 0.1, 0.2, 0.3, 0.4, 0.5 0 ≤ V(R) ≤ 0.3	both cases <i>β vs V(R) type</i>

Reliability equations developed from root form. (Ang and Cornell, p. 1756)

$$\beta_{Normal} = \frac{\theta_0 - 1}{\sqrt{V_R^2 \theta_0 + V_S^2}} \qquad \beta_{Log-Normal} = \frac{\ln \left[\theta_0 \sqrt{\frac{1 + V_S^2}{1 + V_R^2}} \right]}{\sqrt{\ln \left[(1 + V_R^2)(1 + V_S^2) \right]}}$$

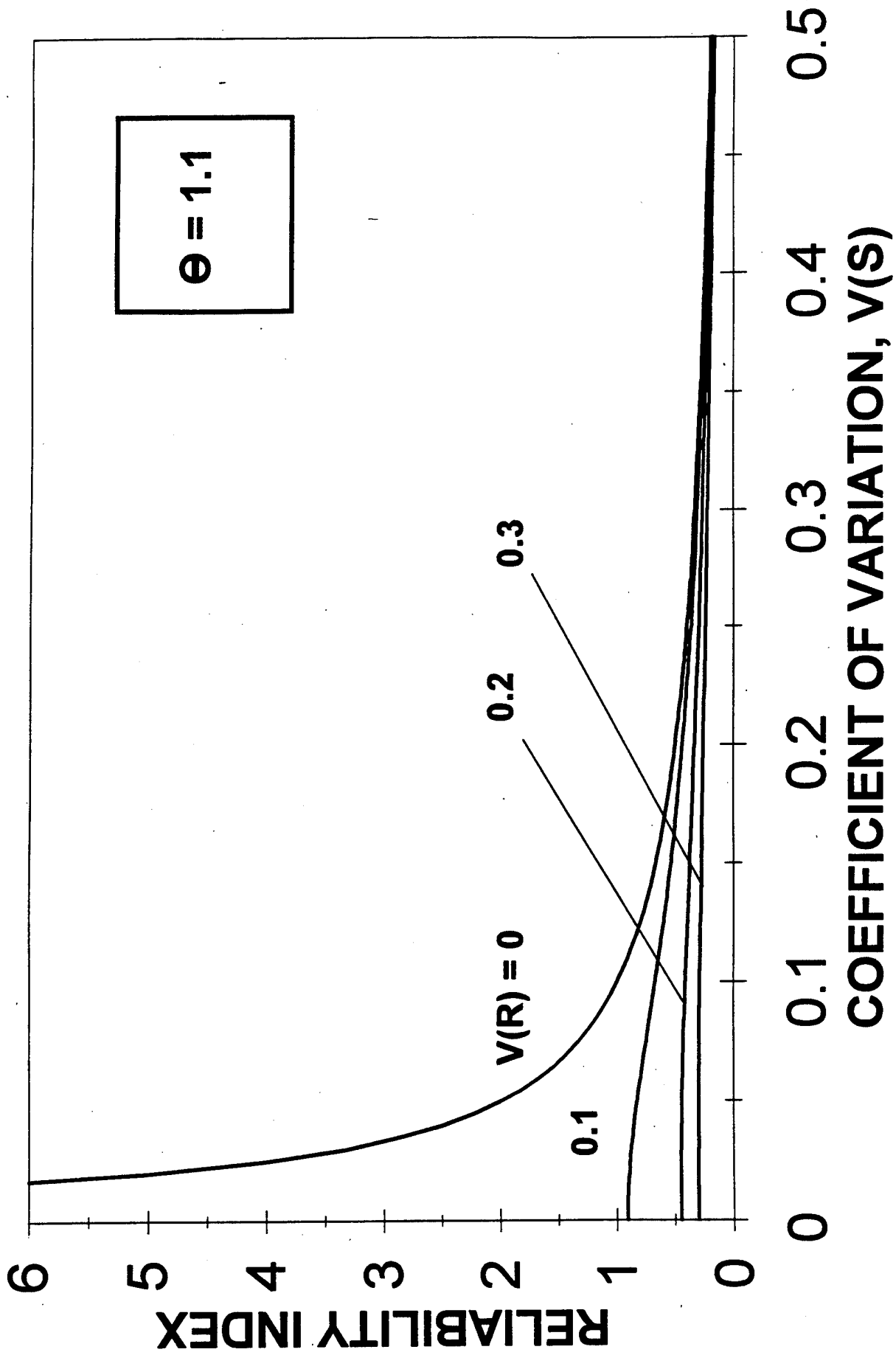

R: NORMAL, S: NORMAL

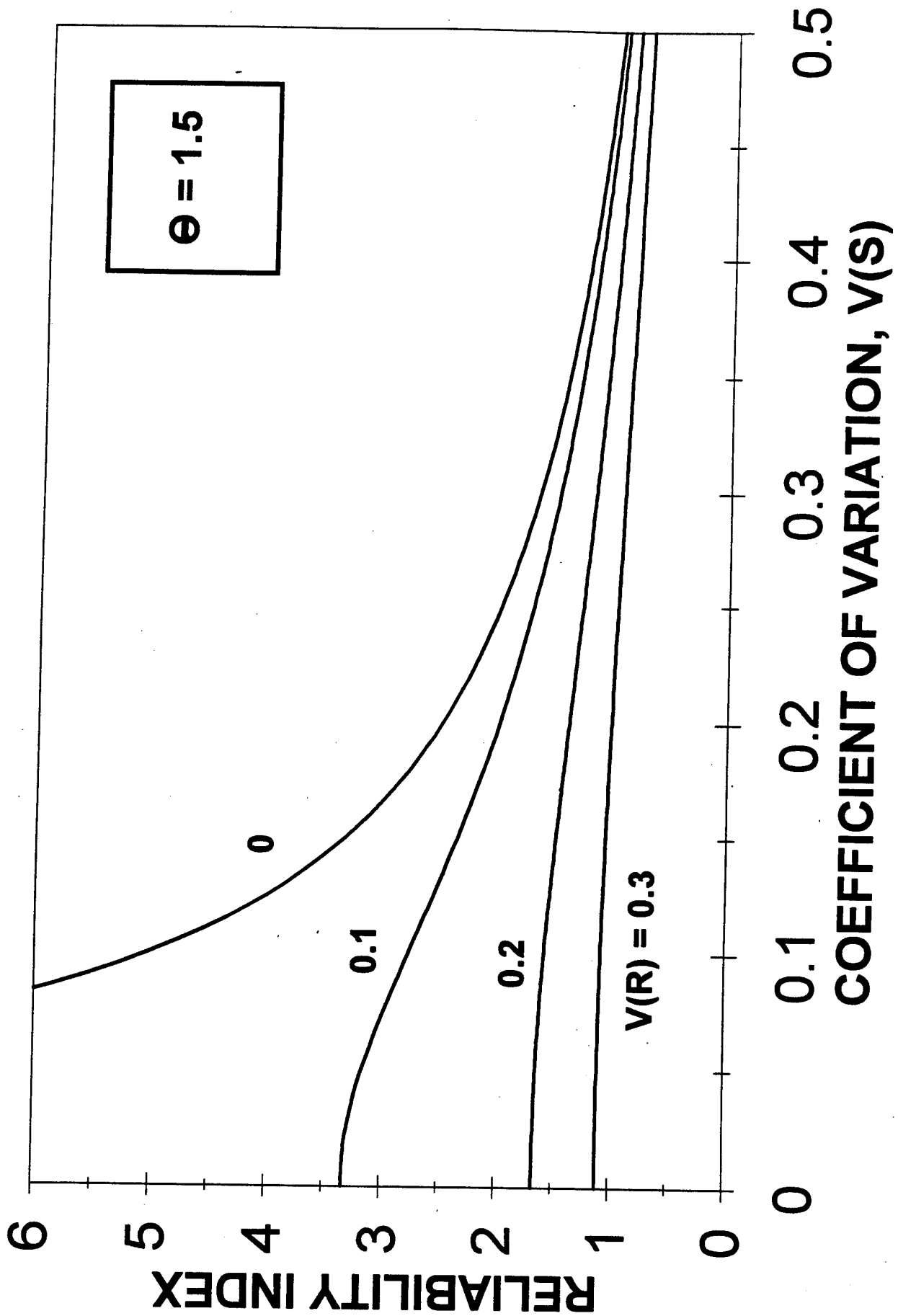

R: NORMAL, S: NORMAL

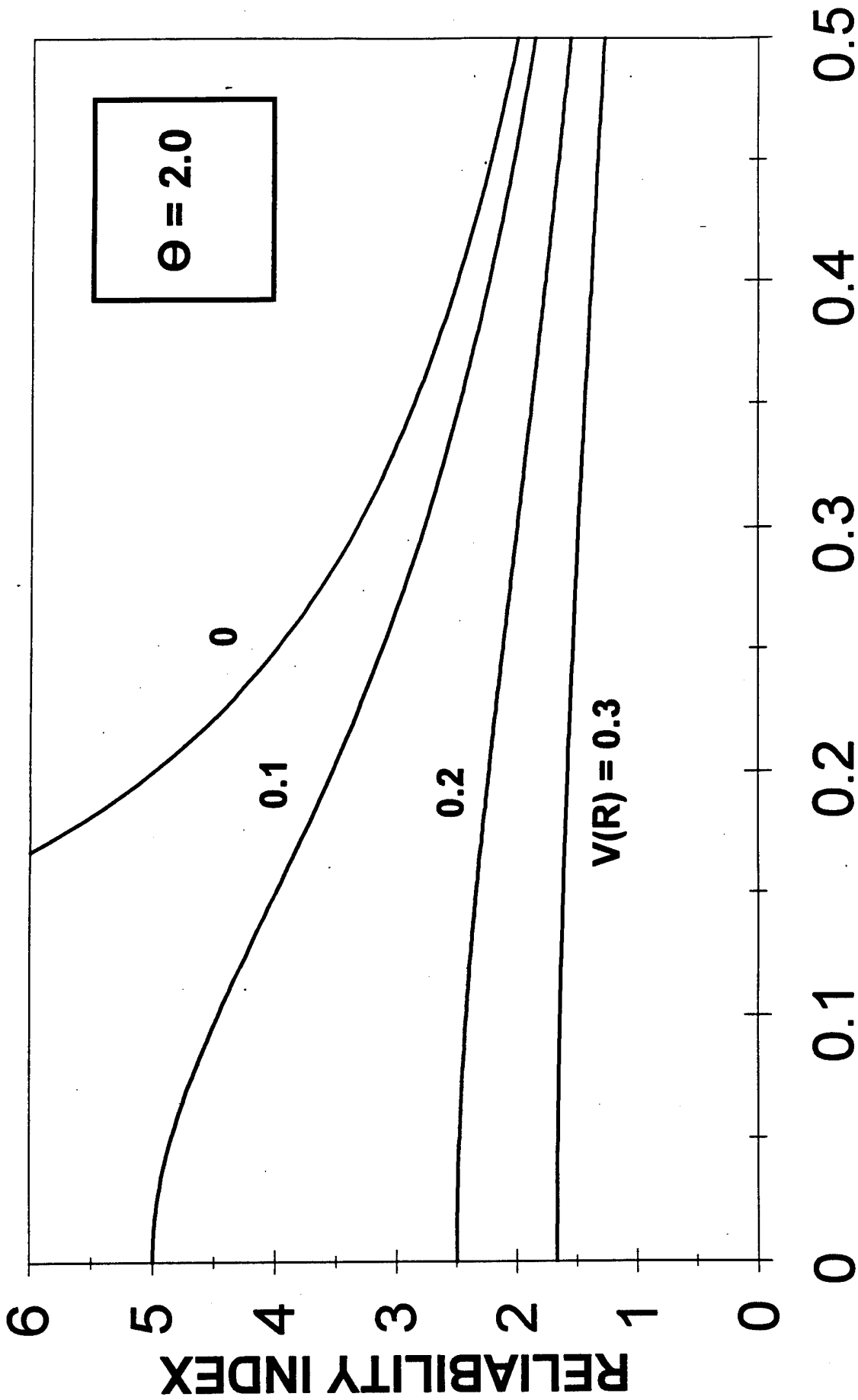

R: NORMAL, S: NORMAL

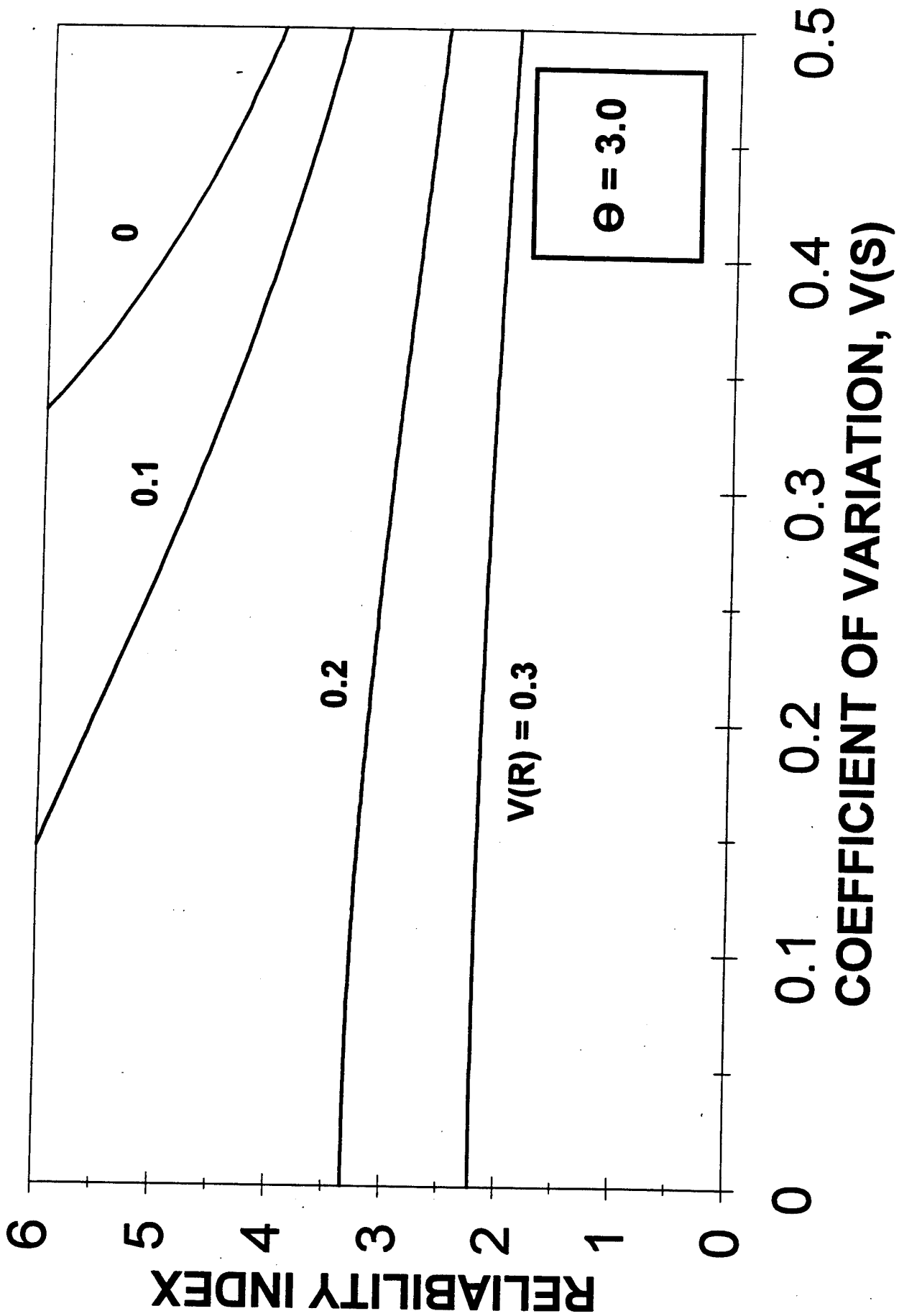

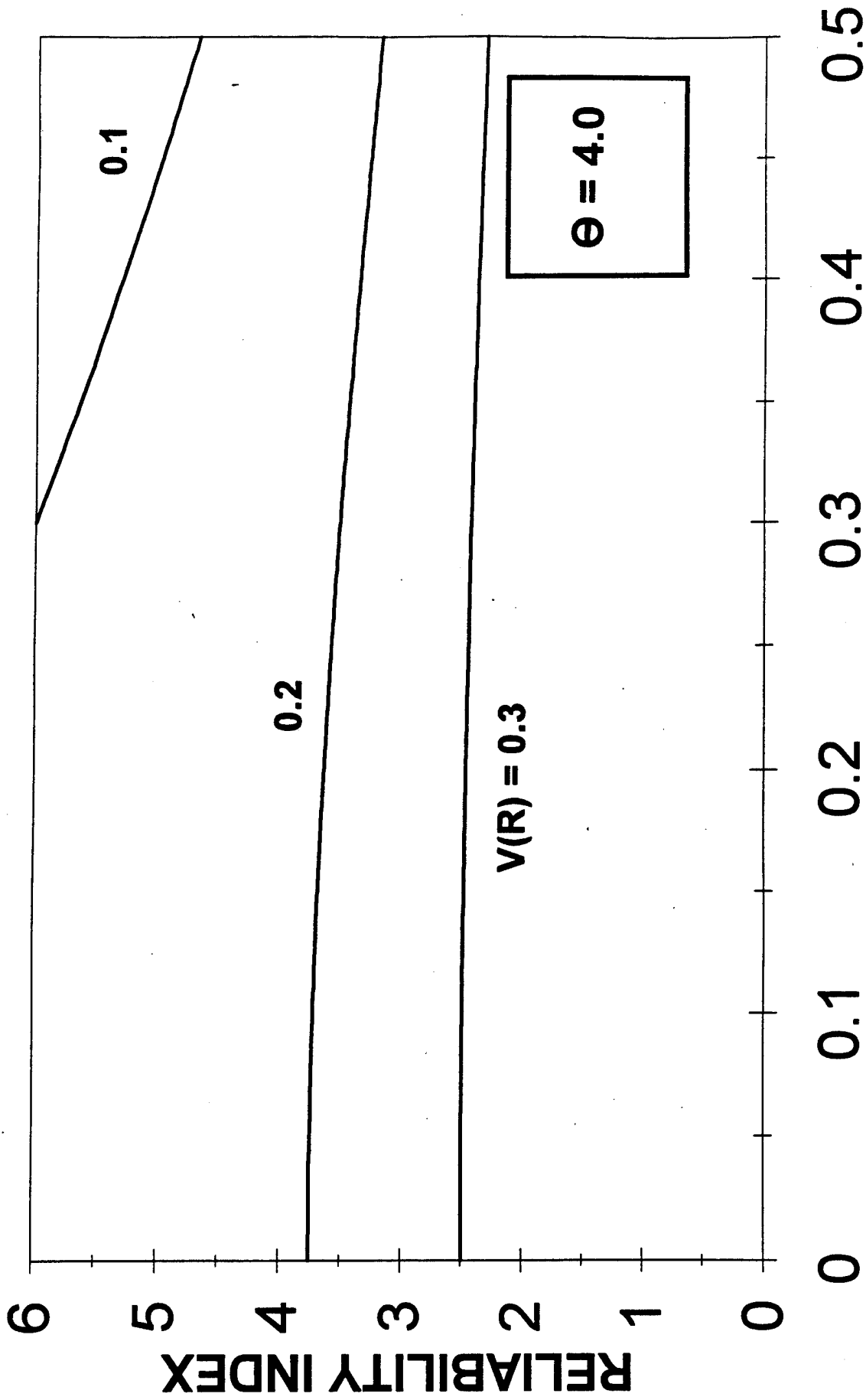

R: NORMAL, S: NORMAL

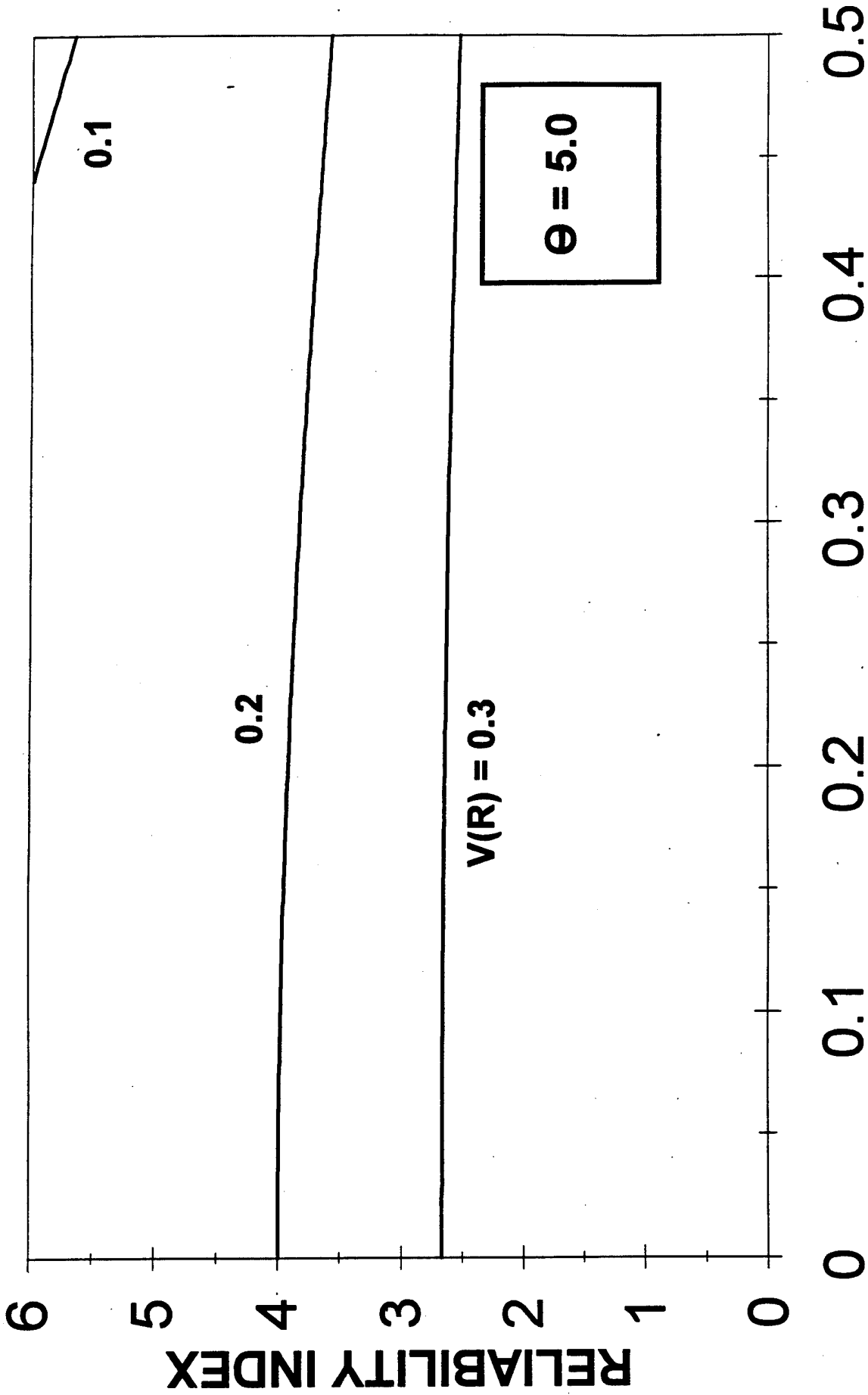

R: NORMAL, S: NORMAL

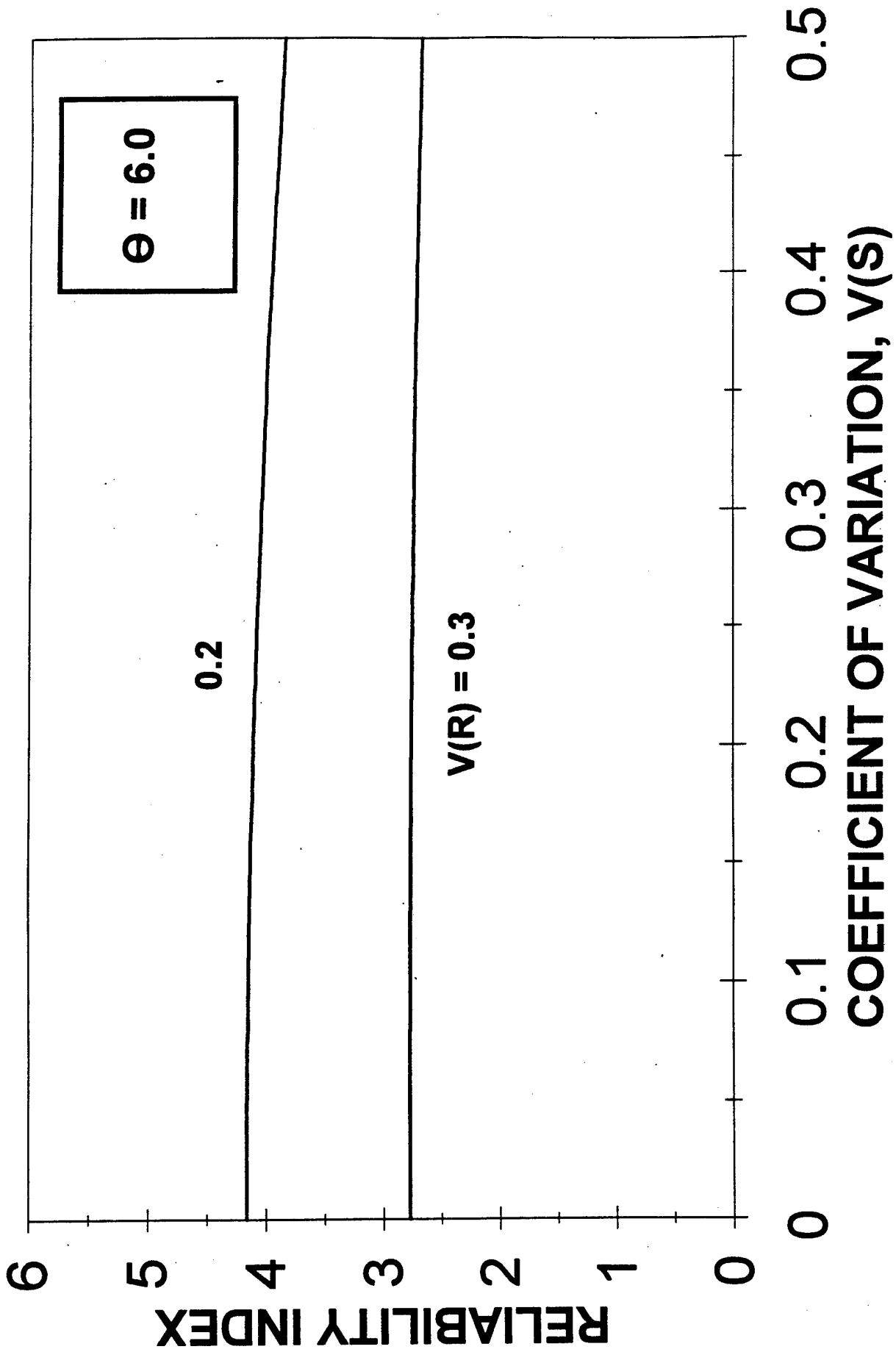

R: NORMAL, S: NORMAL

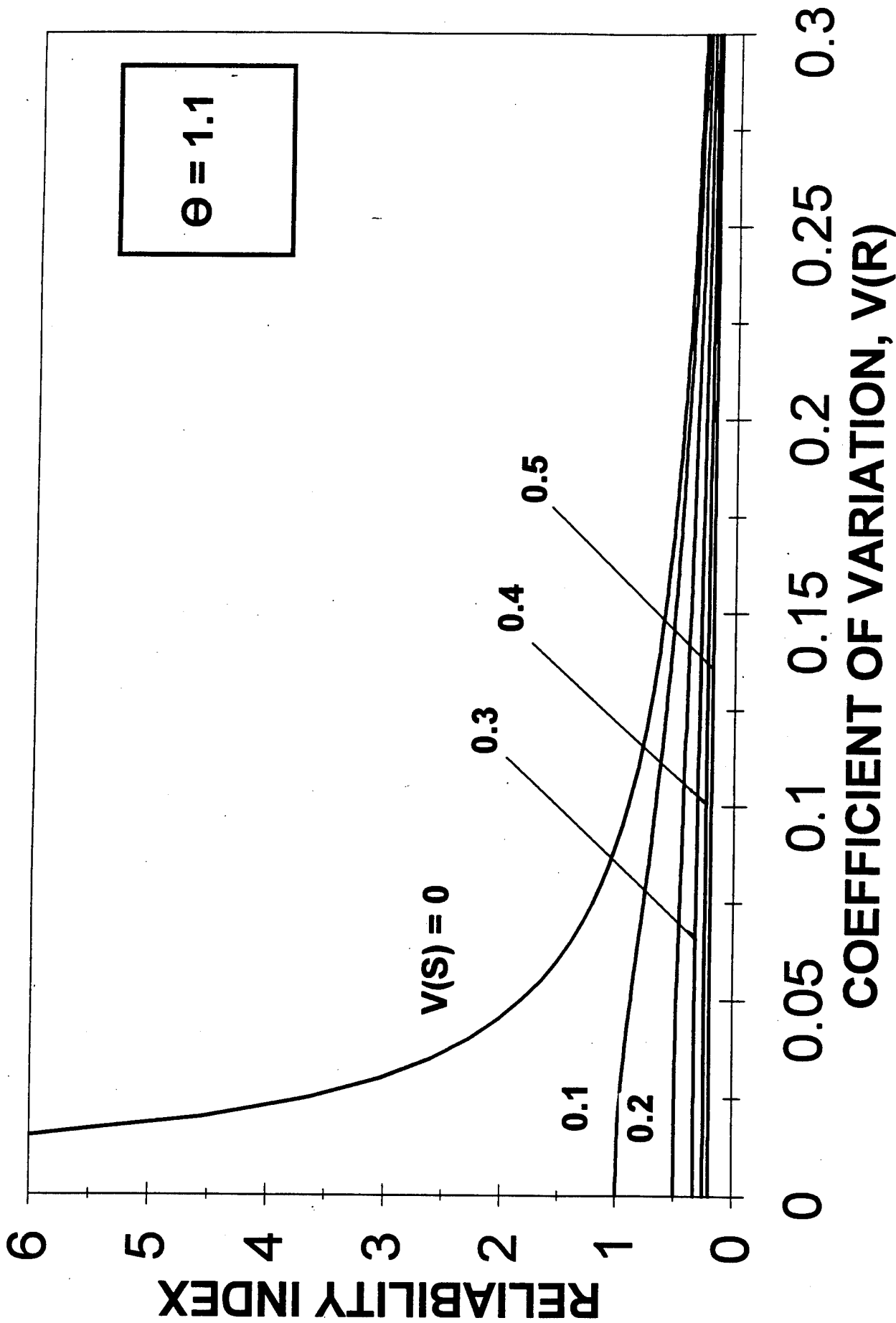

R: NORMAL, S: NORMAL

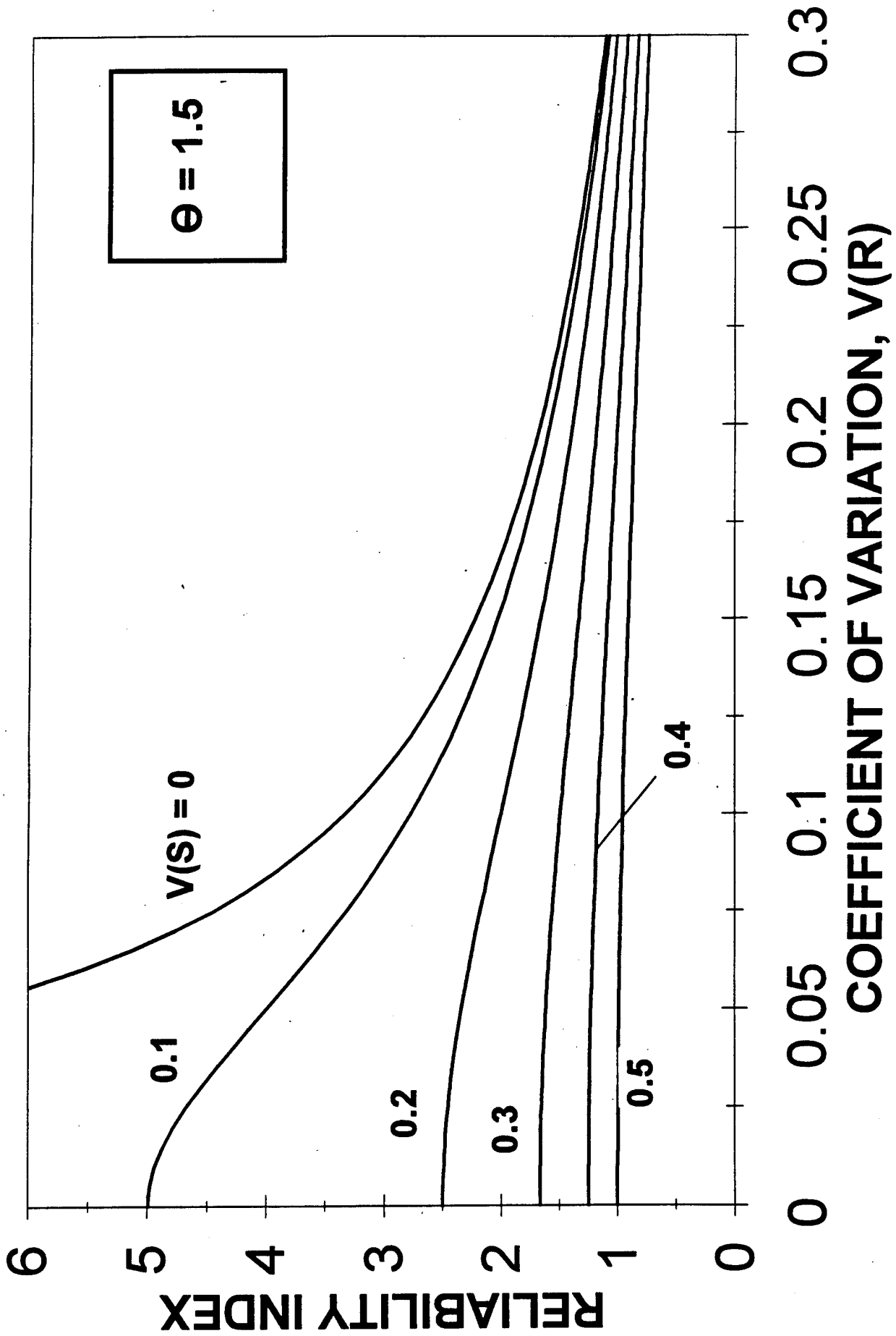

R: NORMAL, S: NORMAL

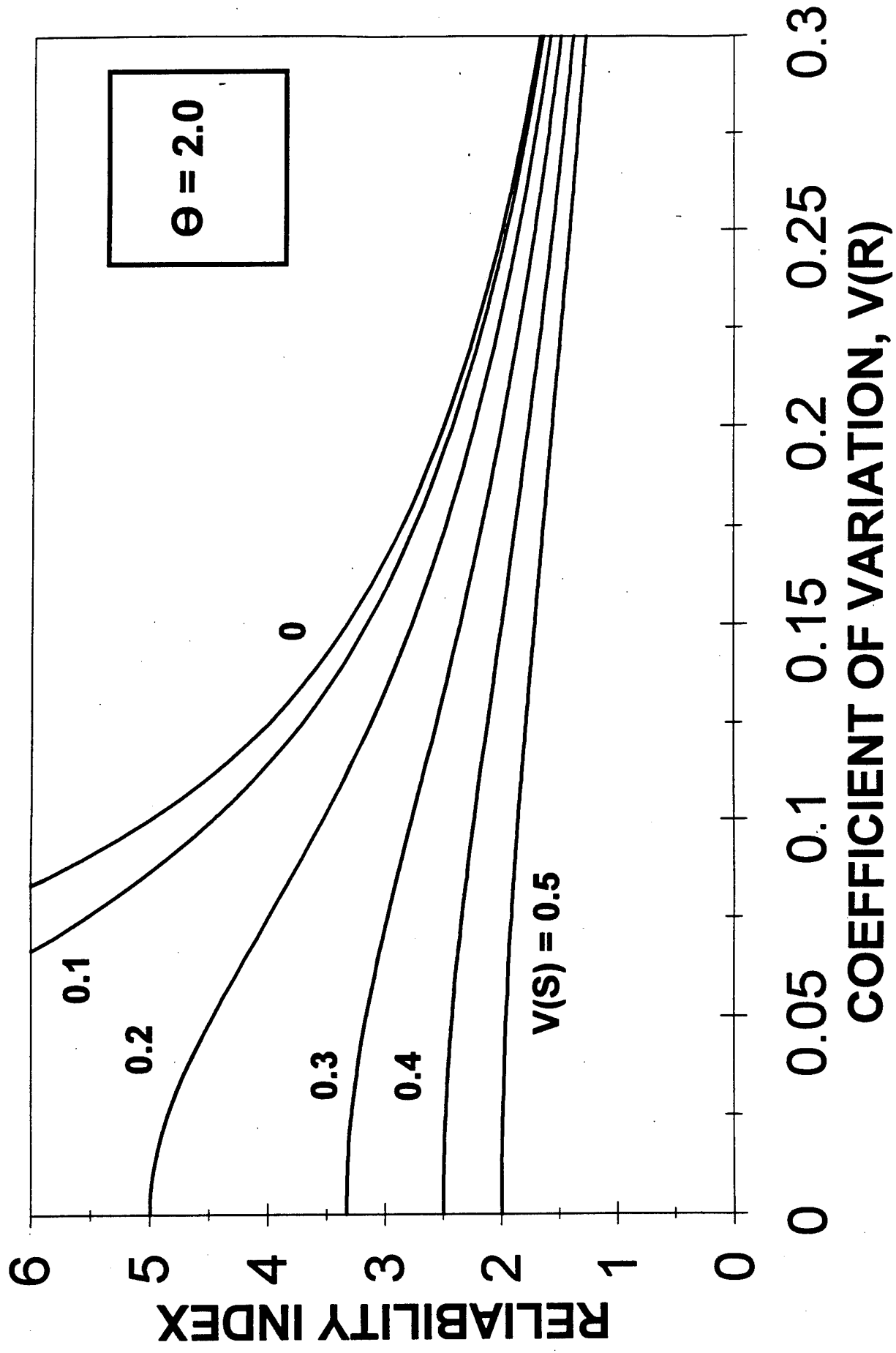

R: NORMAL, S: NORMAL

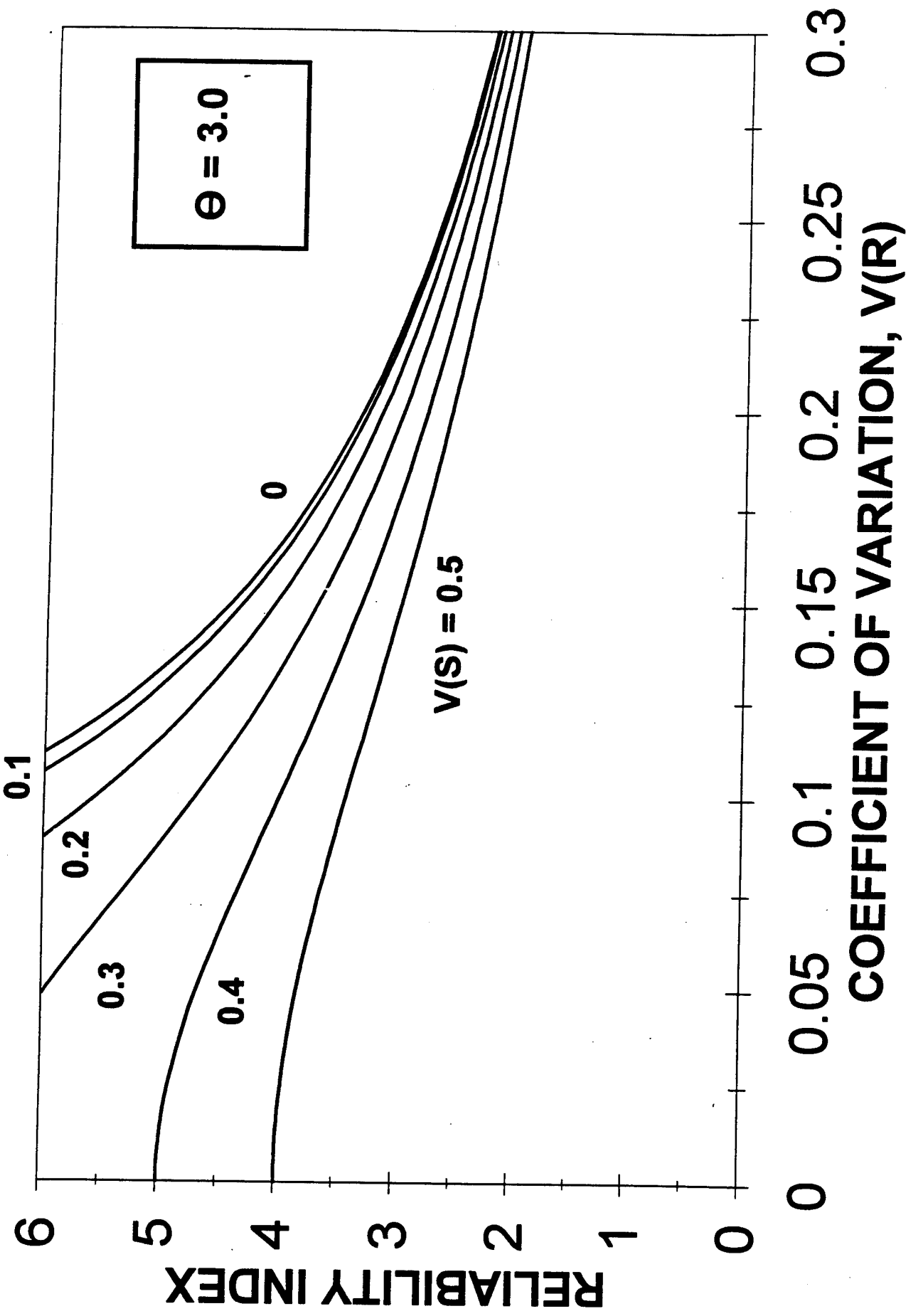

R: NORMAL, S: NORMAL

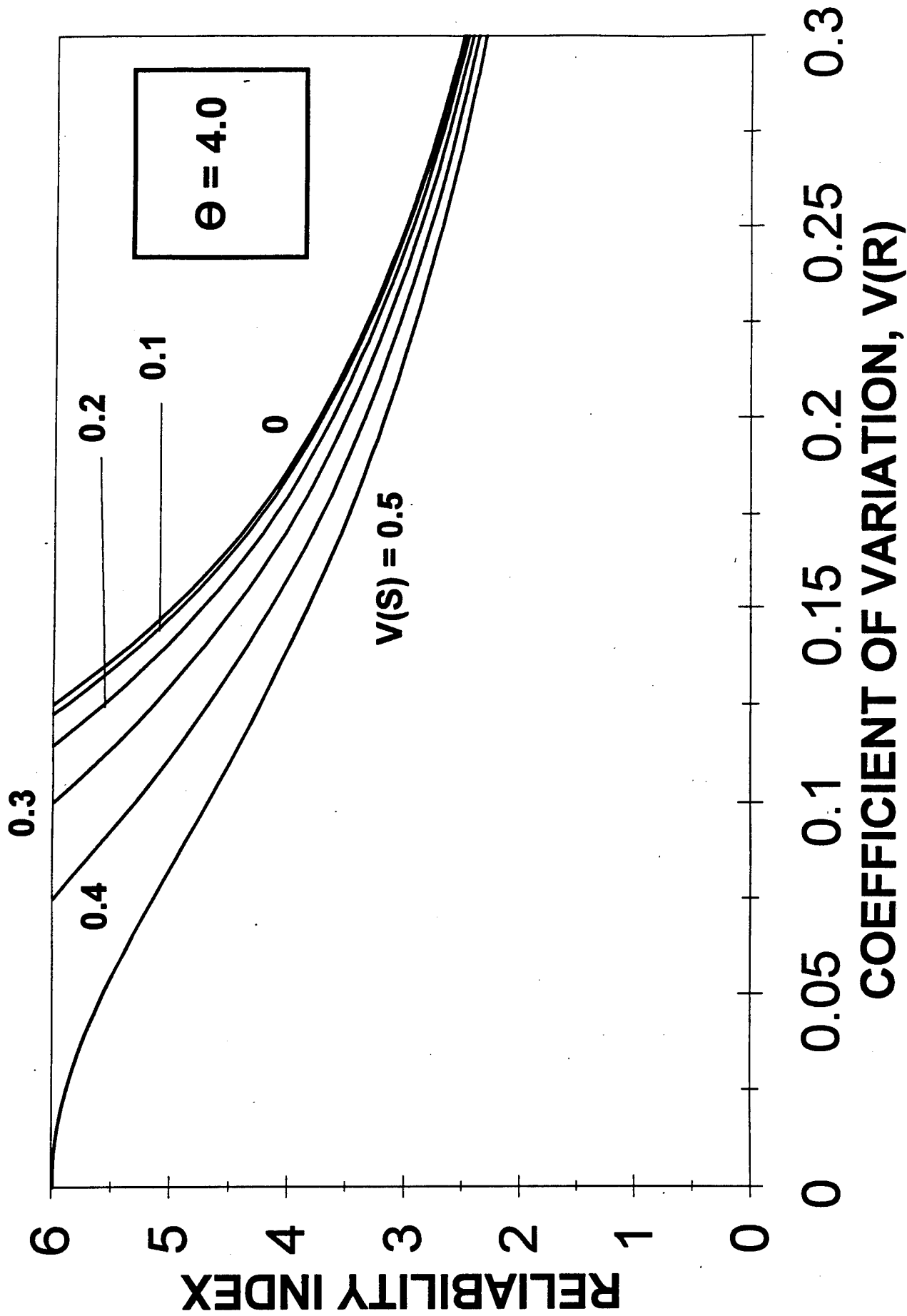

R: NORMAL, S: NORMAL

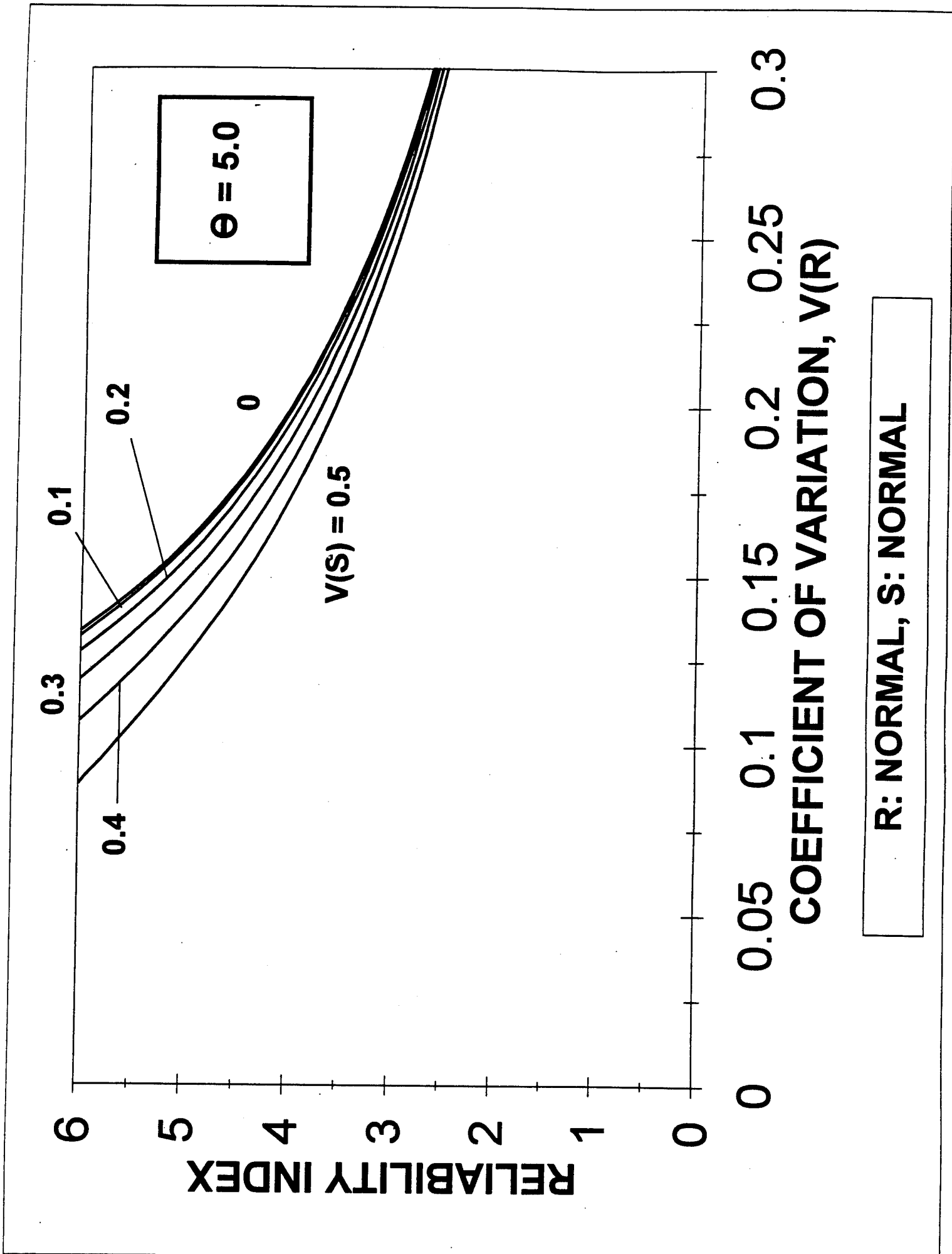

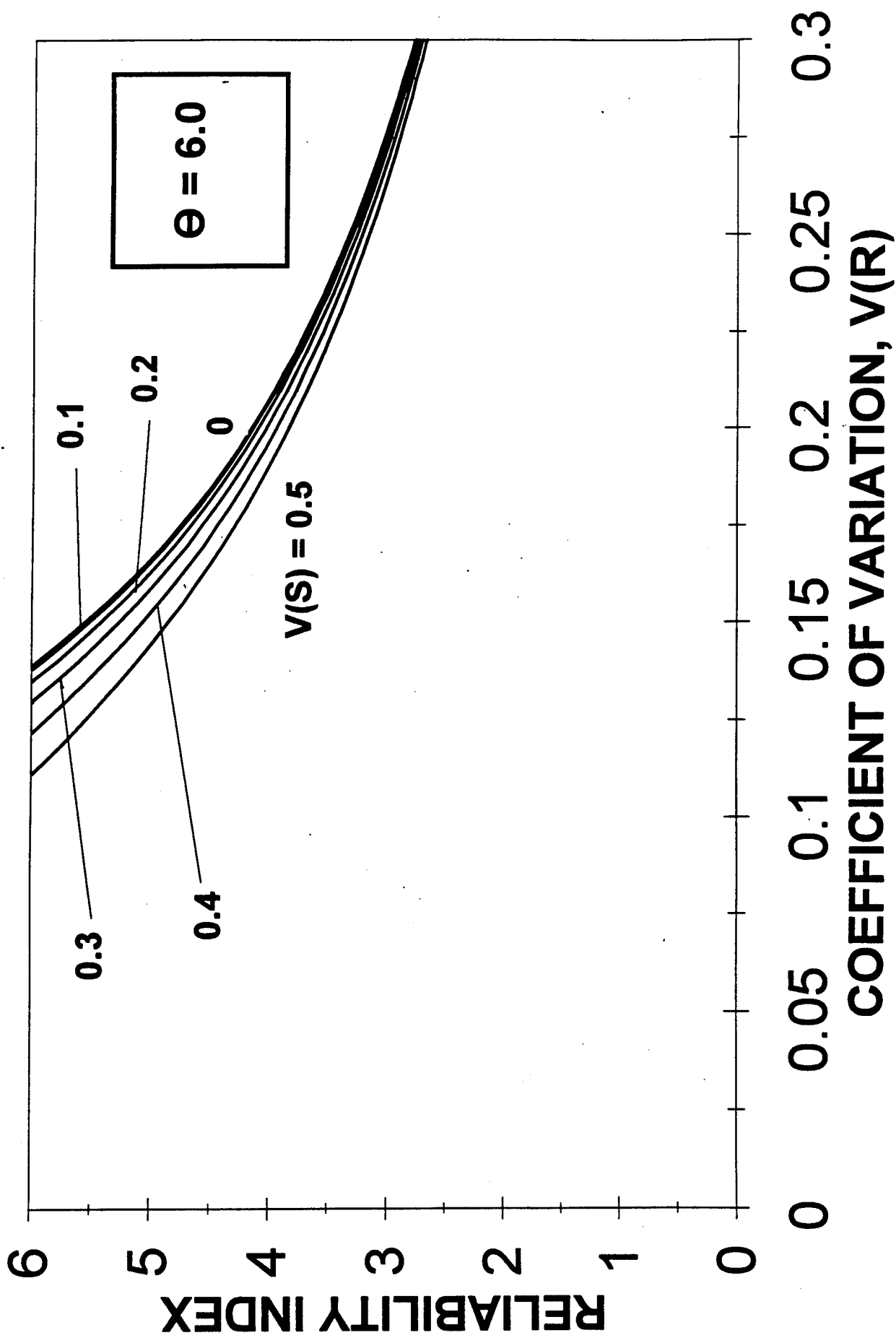

R: NORMAL, S: NORMAL

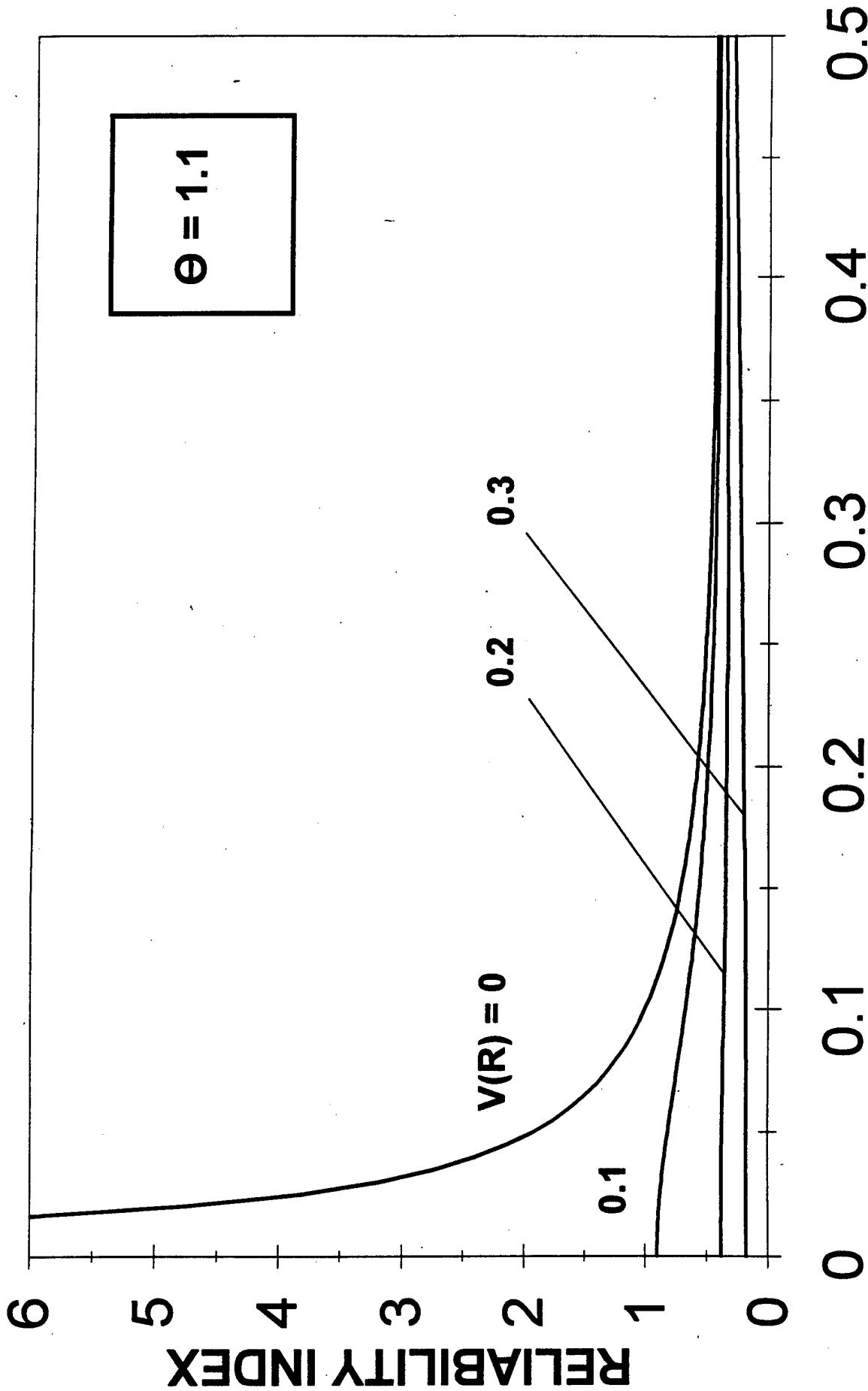

R: LOG-NORMAL, S: LOG-NORMAL

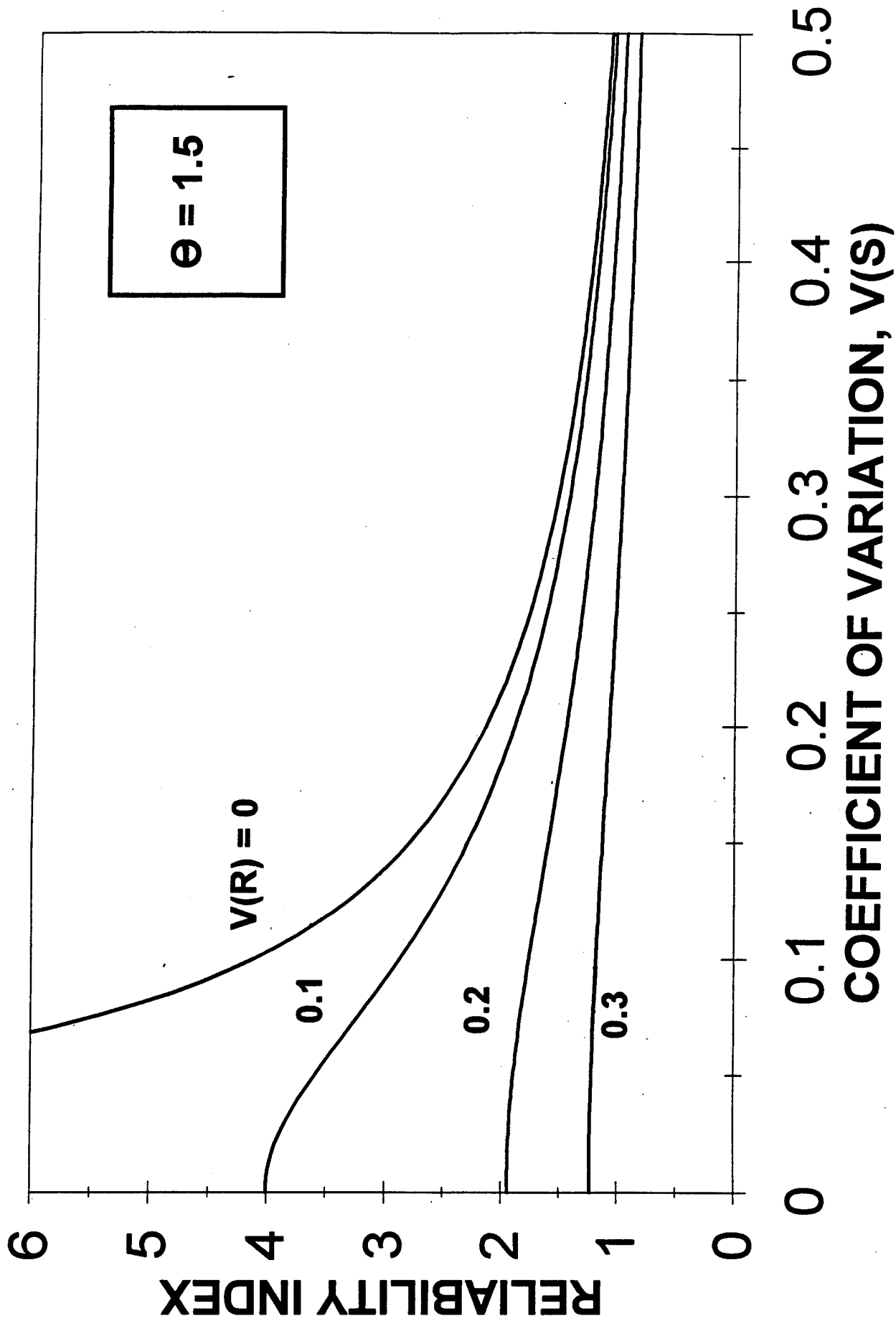

R: LOG-NORMAL, S: LOG-NORMAL

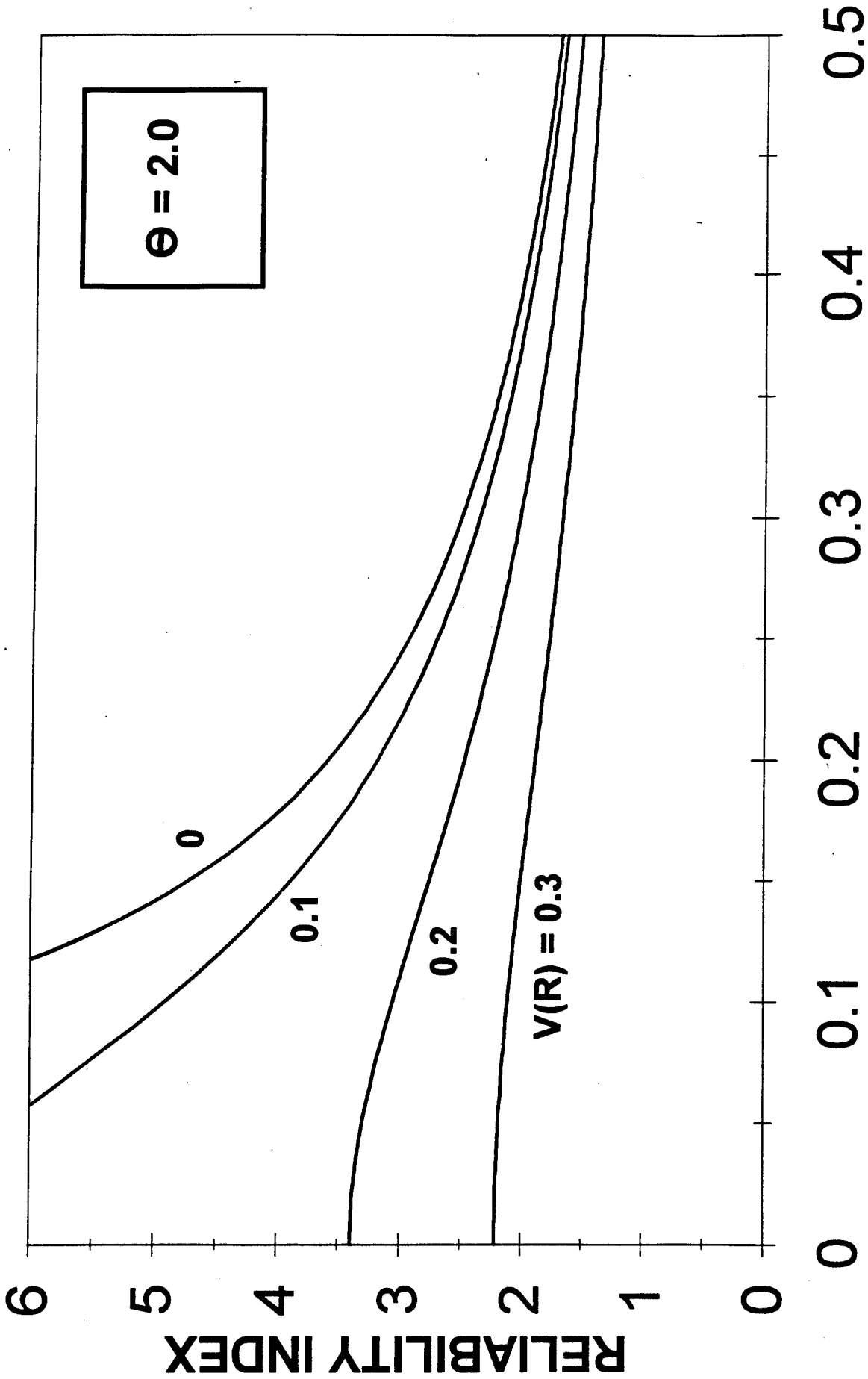

R: LOG-NORMAL, S: LOG-NORMAL

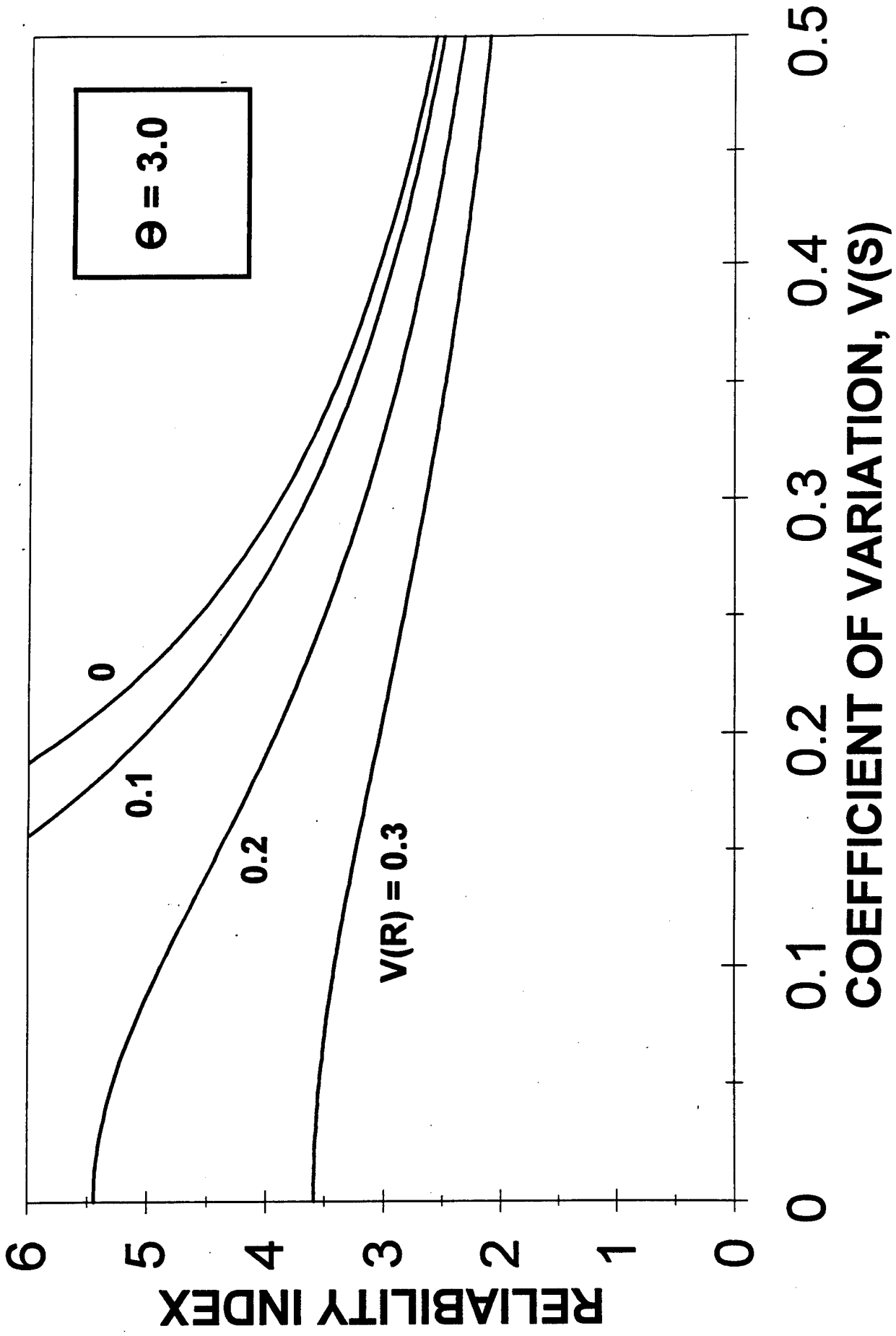

R: LOG-NORMAL, S: LOG-NORMAL

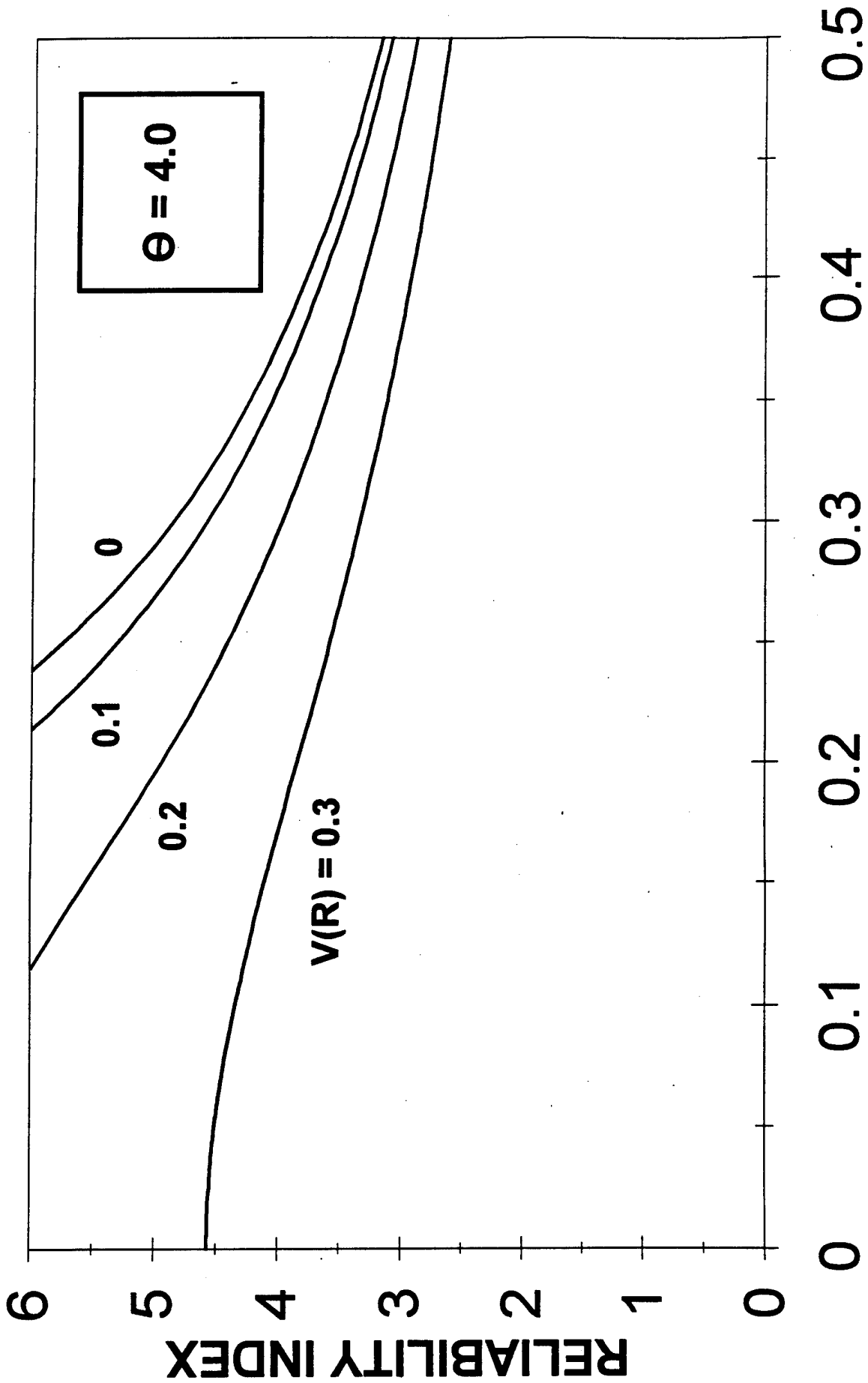

R: LOG-NORMAL, S: LOG-NORMAL

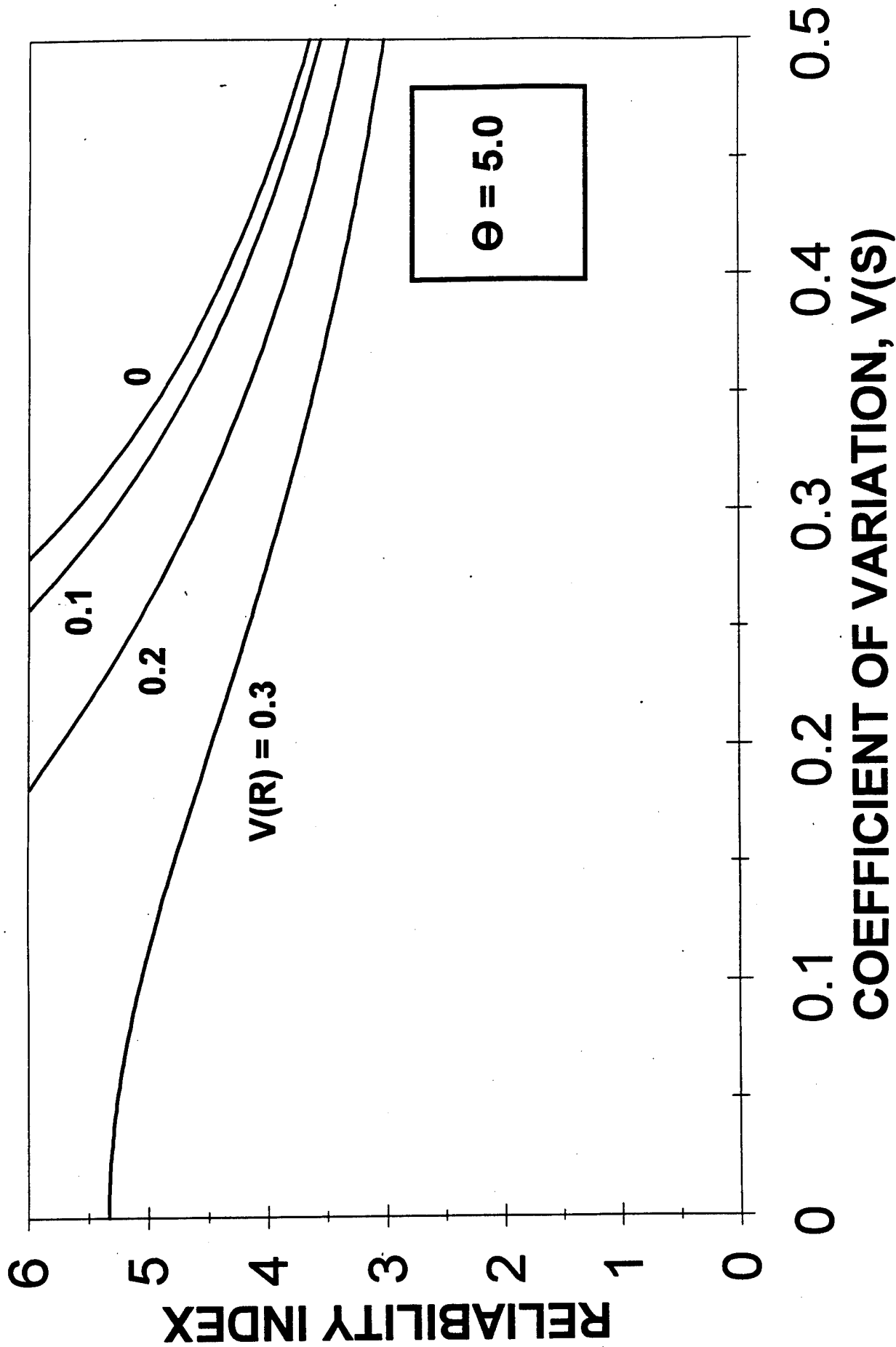

R: LOG-NORMAL, S: LOG-NORMAL

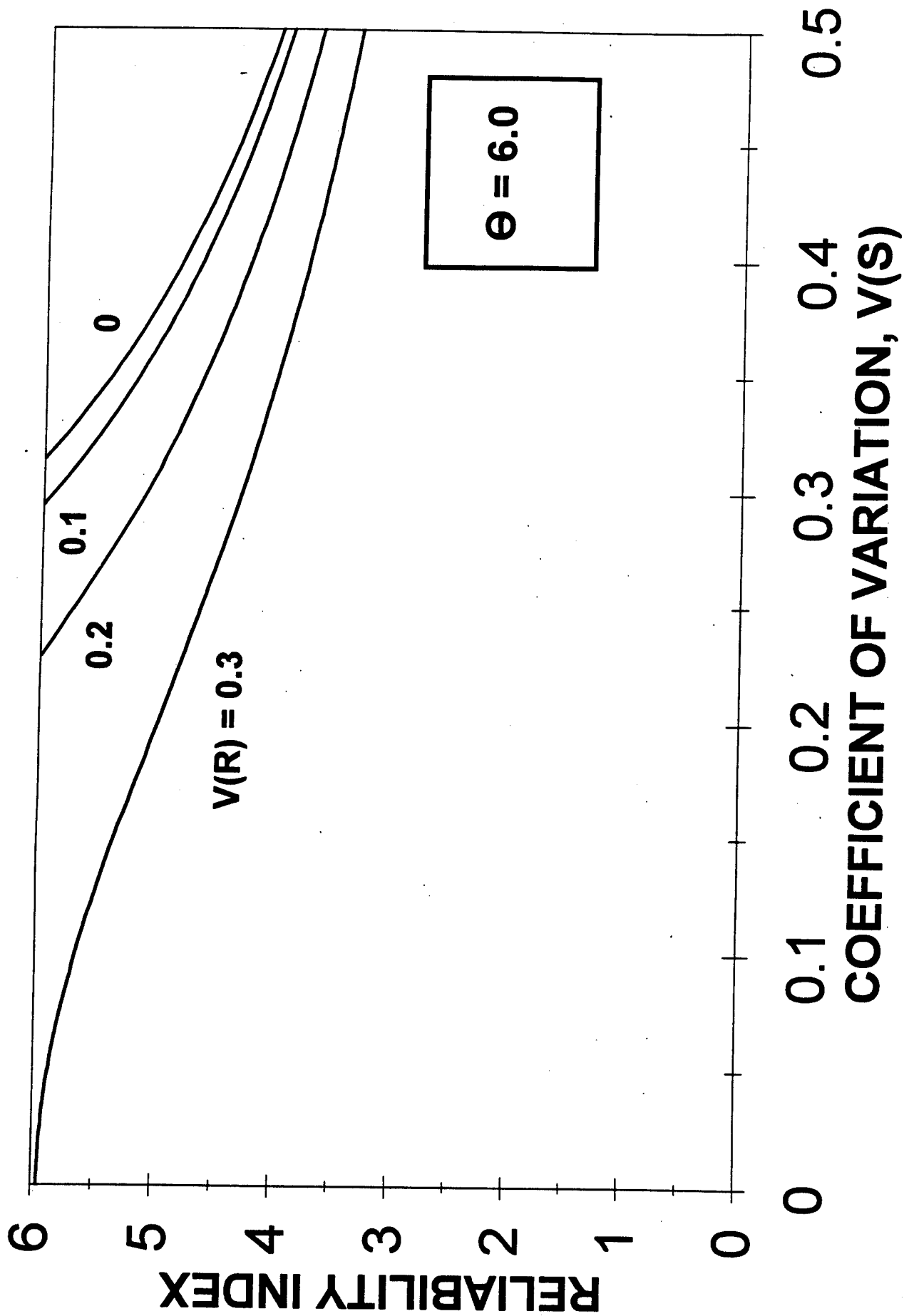

R: LOG-NORMAL, S: LOG-NORMAL

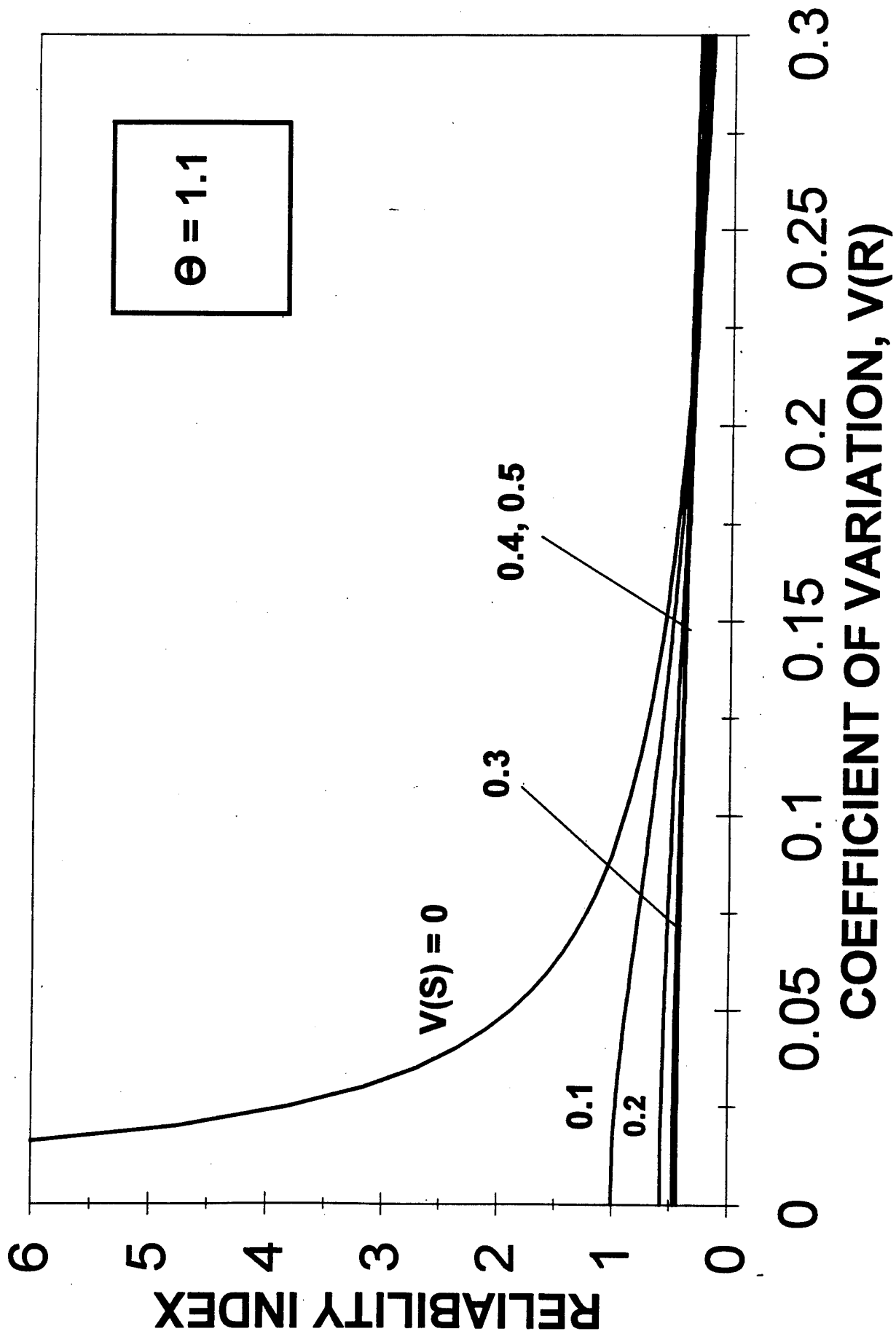

R: LOG-NORMAL, S: LOG-NORMAL

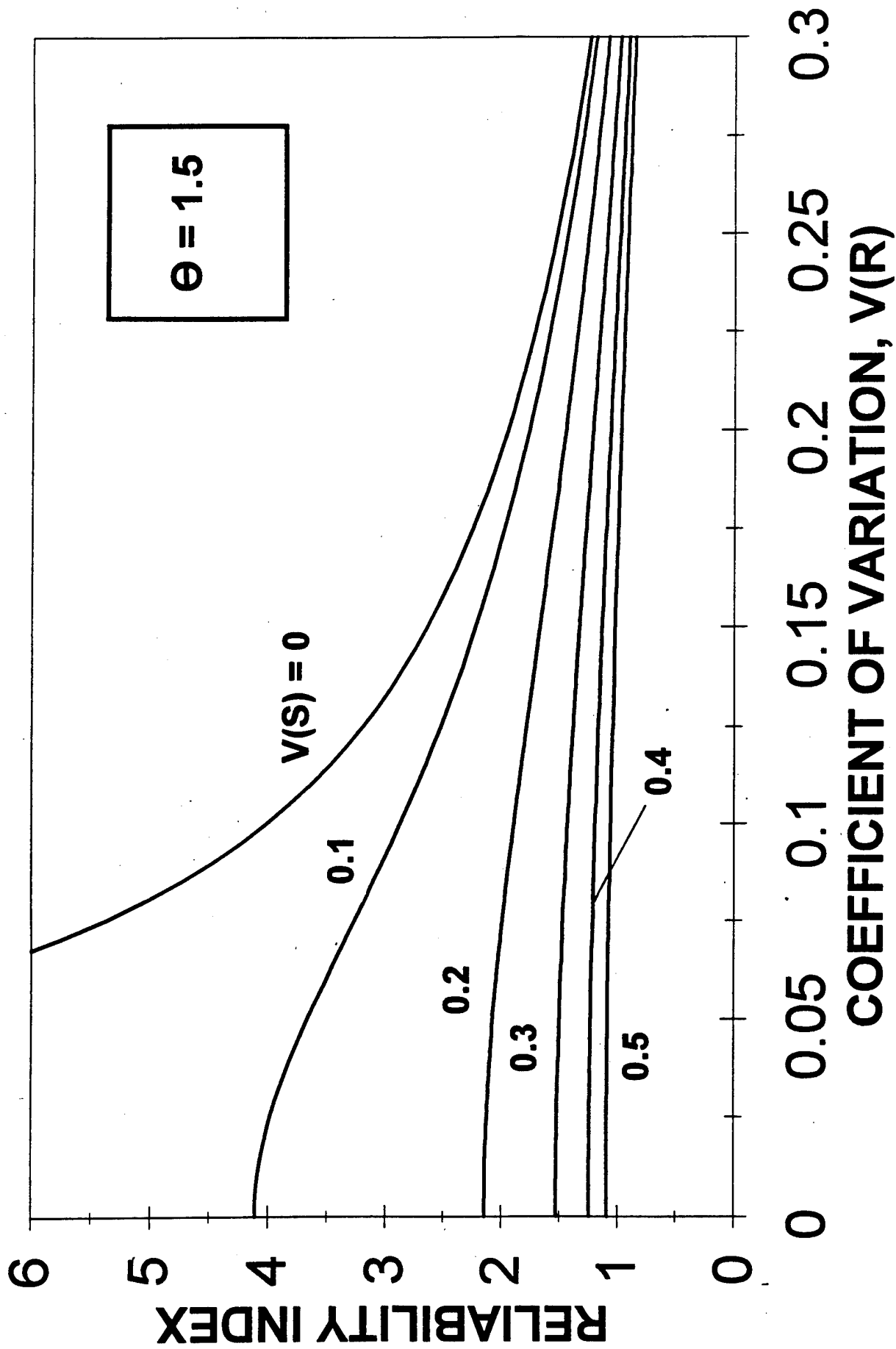

R: LOG-NORMAL, S: LOG-NORMAL

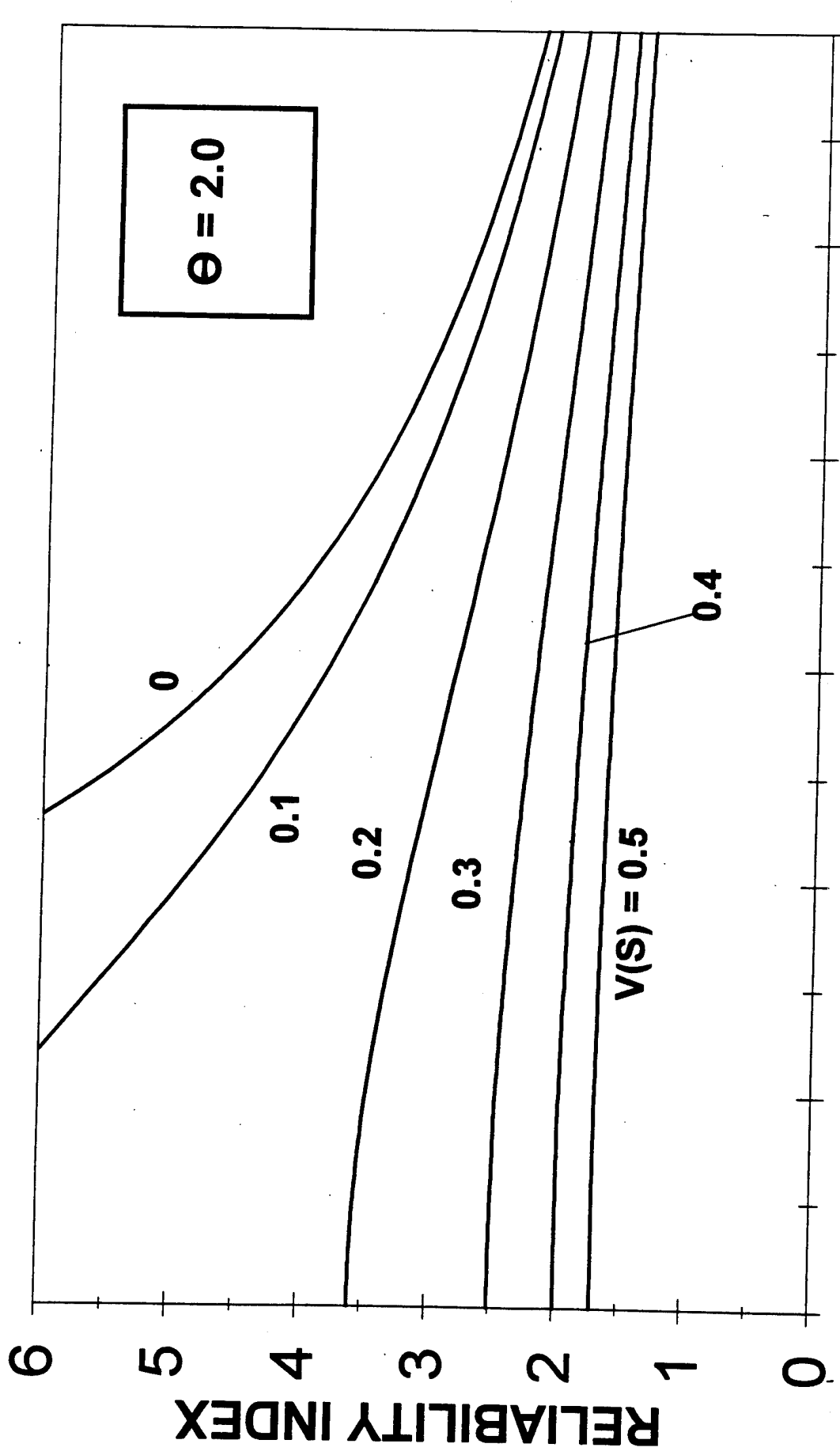

0 0.05 0.1 0.15 0.2 0.25 0.3
 COEFFICIENT OF VARIATION, $V(R)$

R: LOG-NORMAL, S: LOG-NORMAL

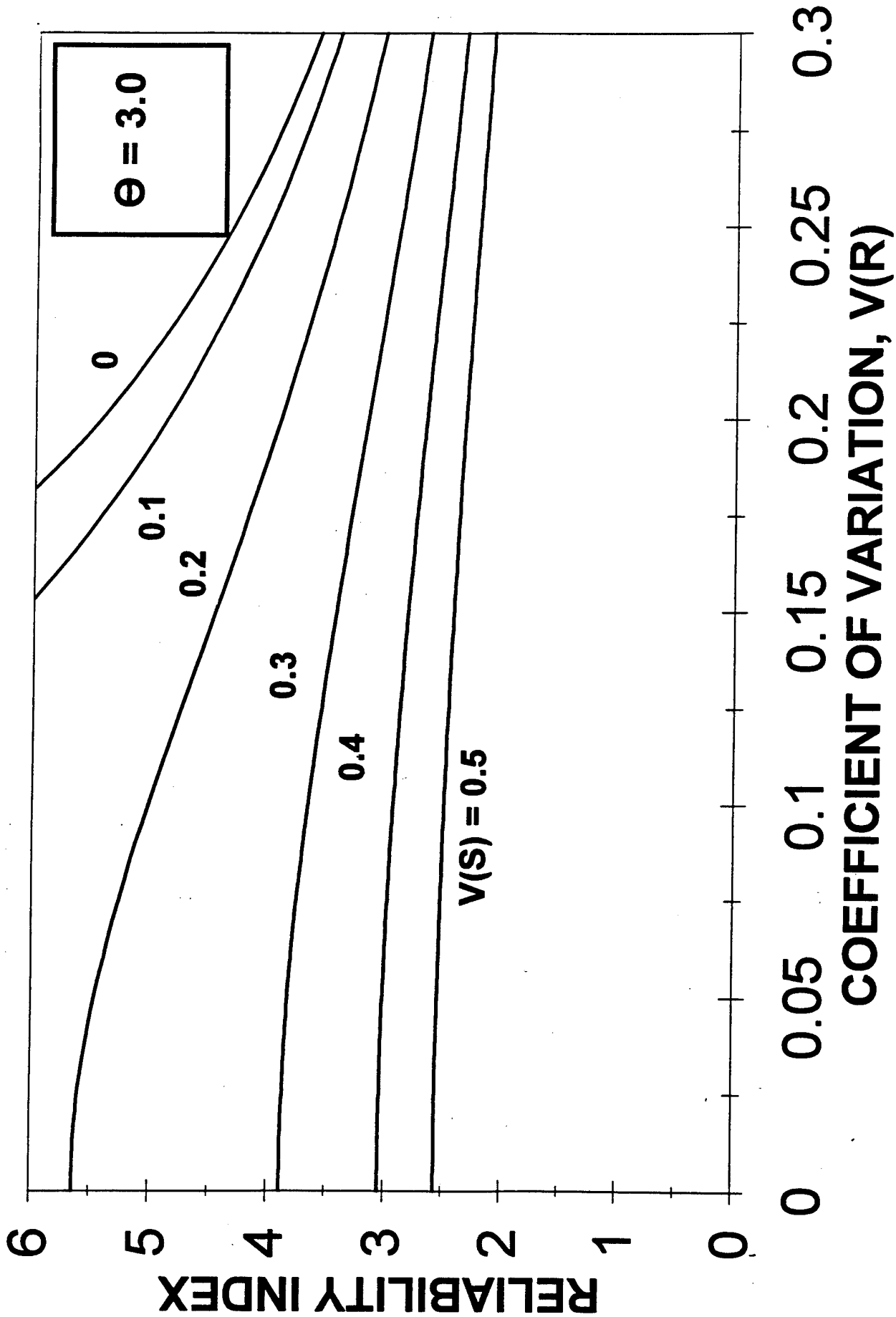

R: LOG-NORMAL, S: LOG-NORMAL

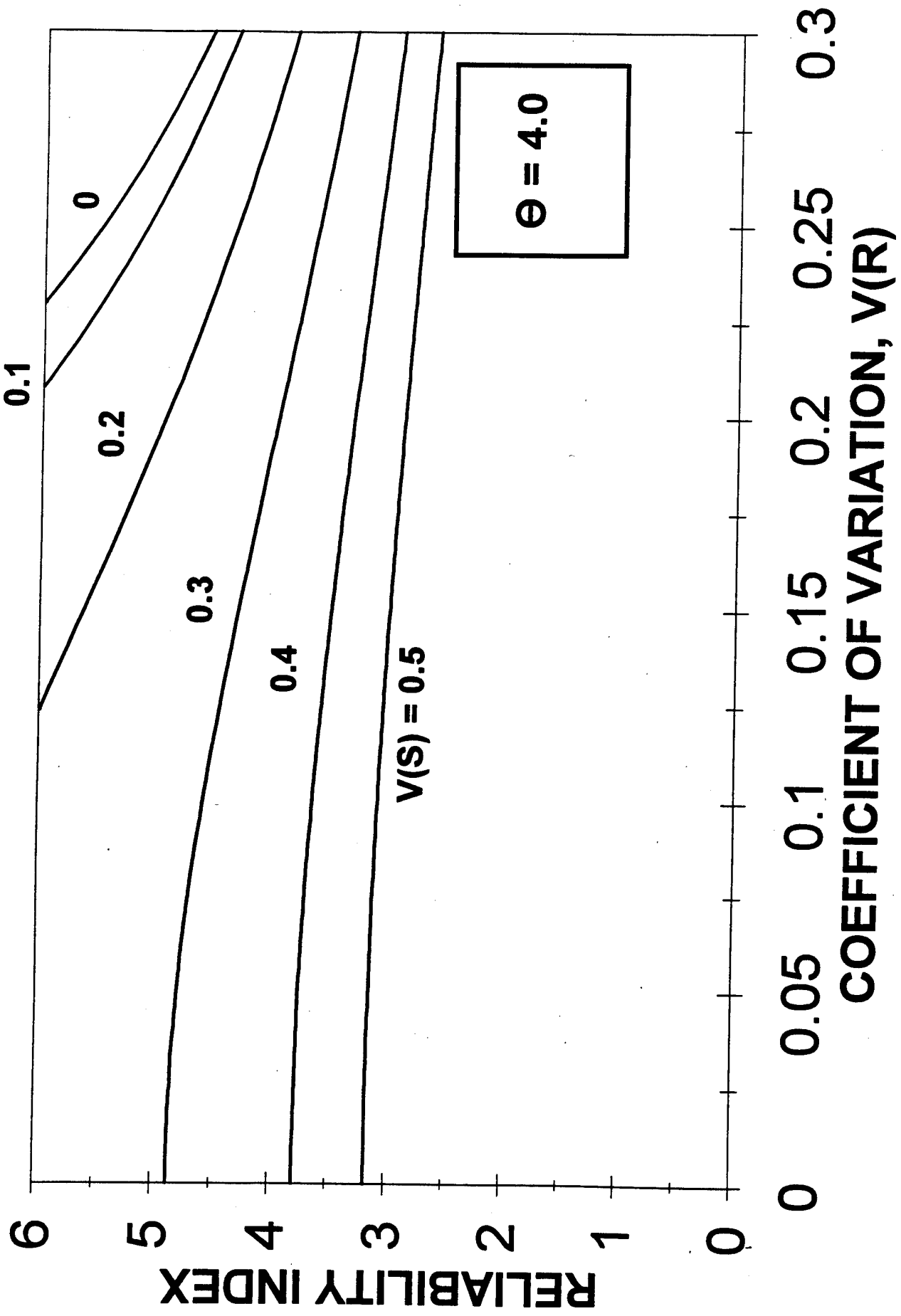

R: LOG-NORMAL, S: LOG-NORMAL

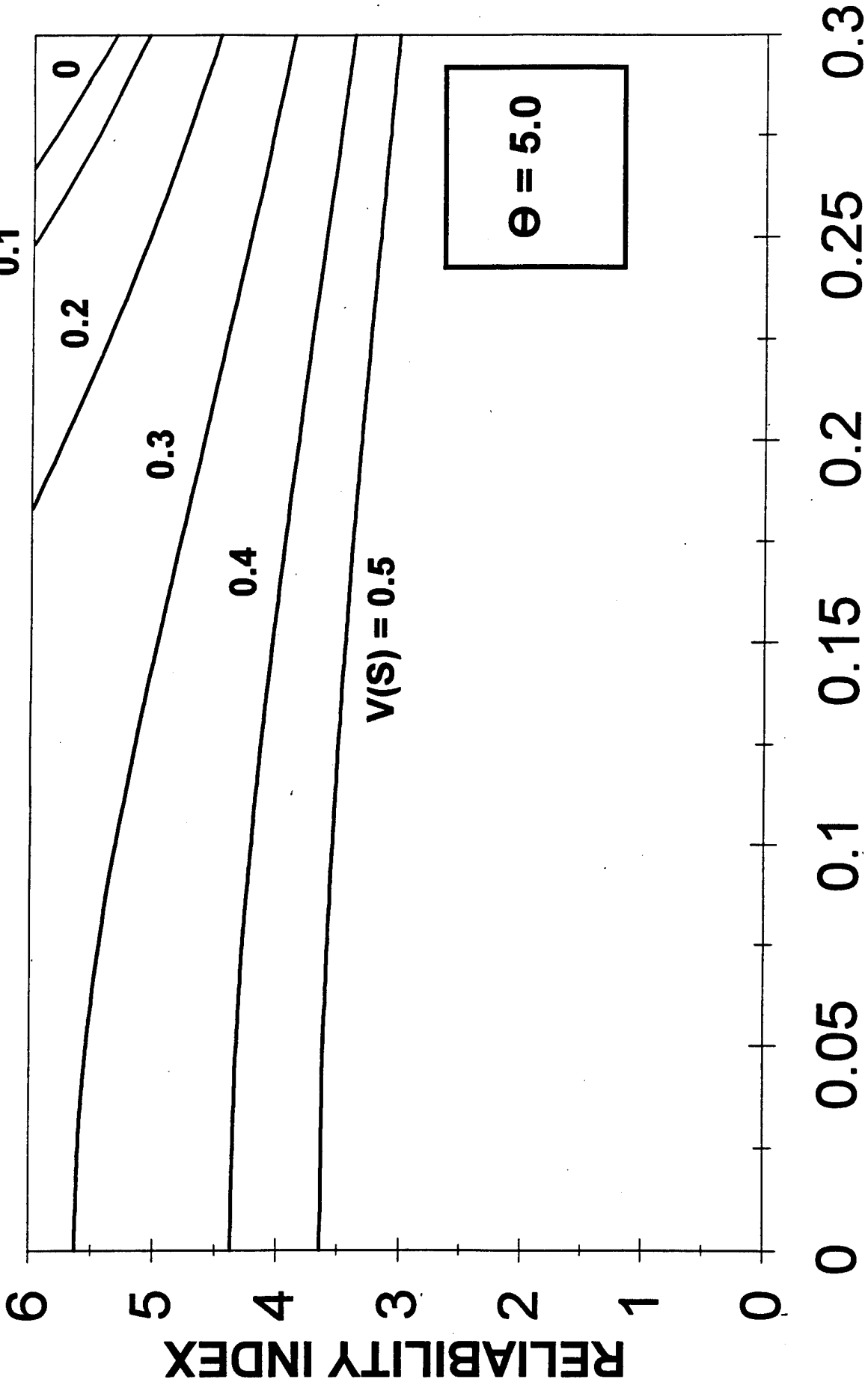

R: LOG-NORMAL, S: LOG-NORMAL

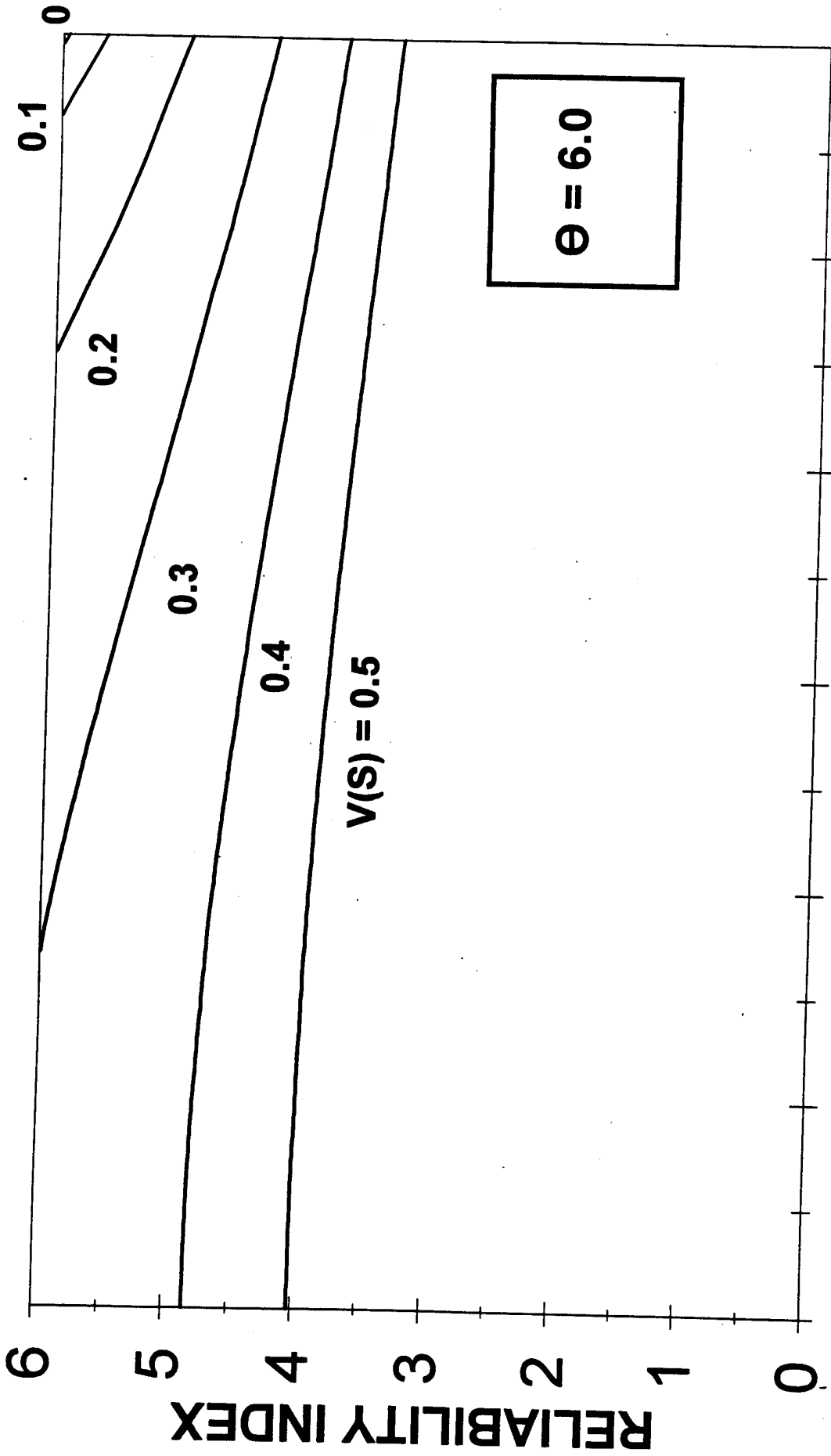

0 0.05 0.1 0.15 0.2 0.25 0.3

COEFFICIENT OF VARIATION, $V(R)$

R: LOG-NORMAL, S: LOG-NORMAL

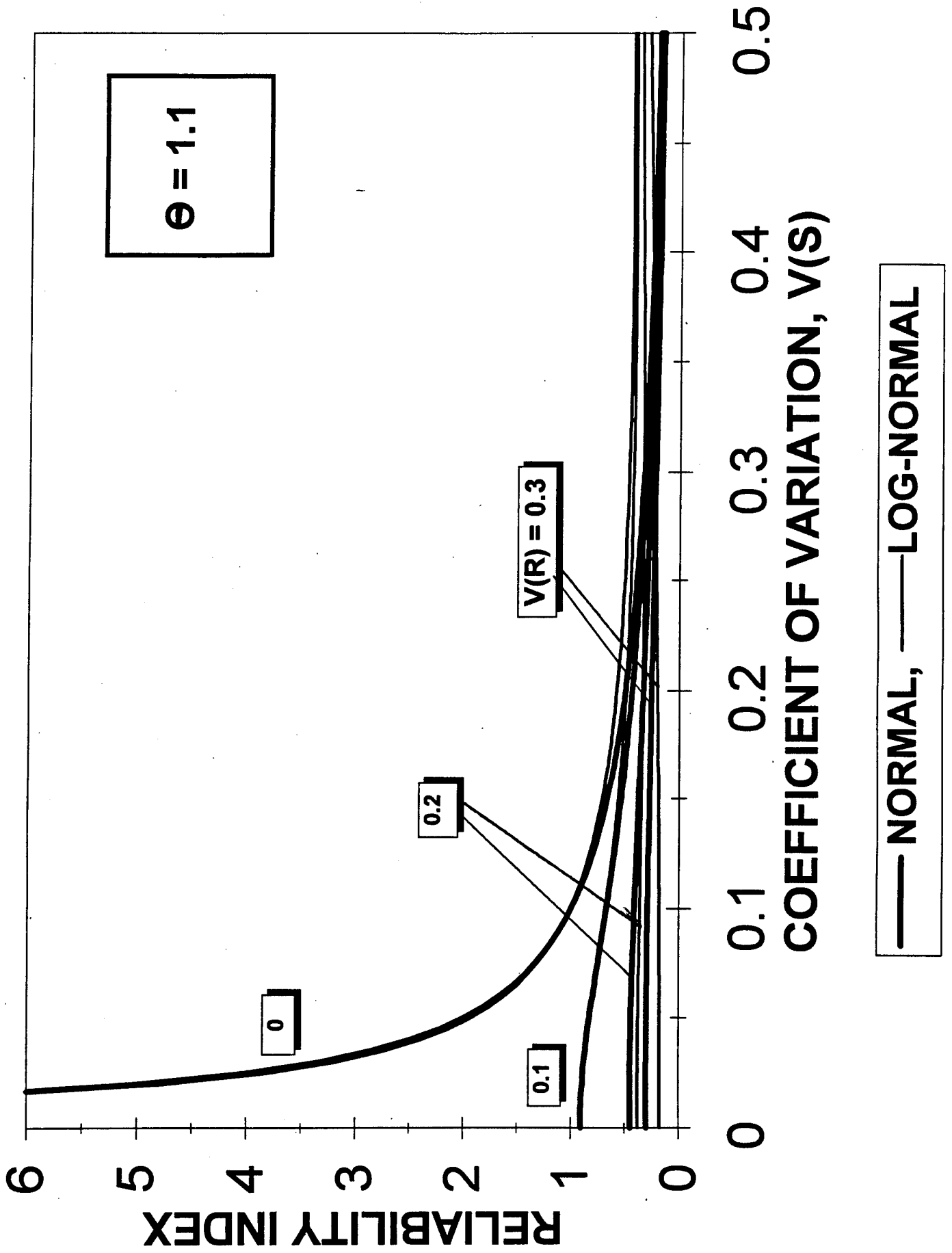

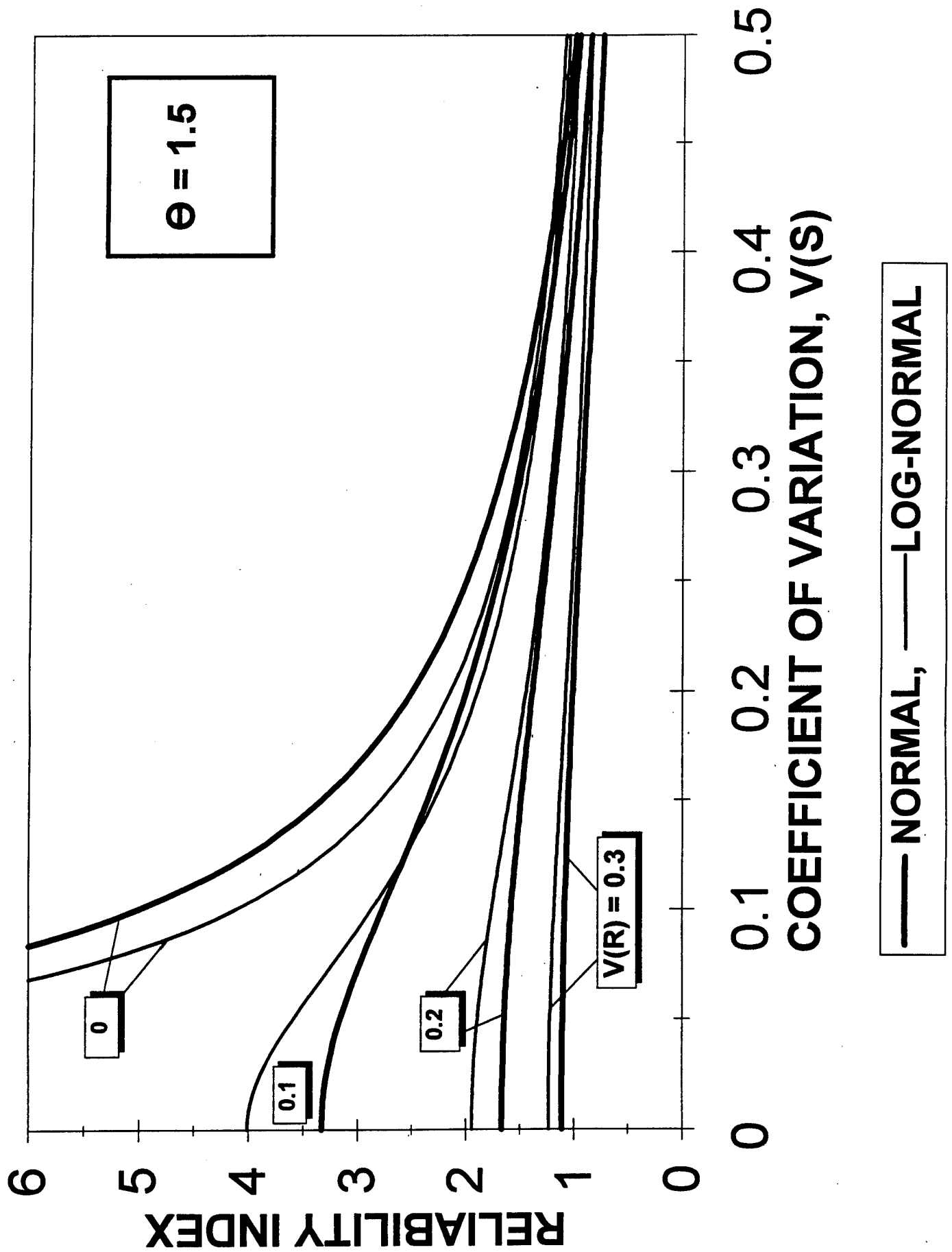

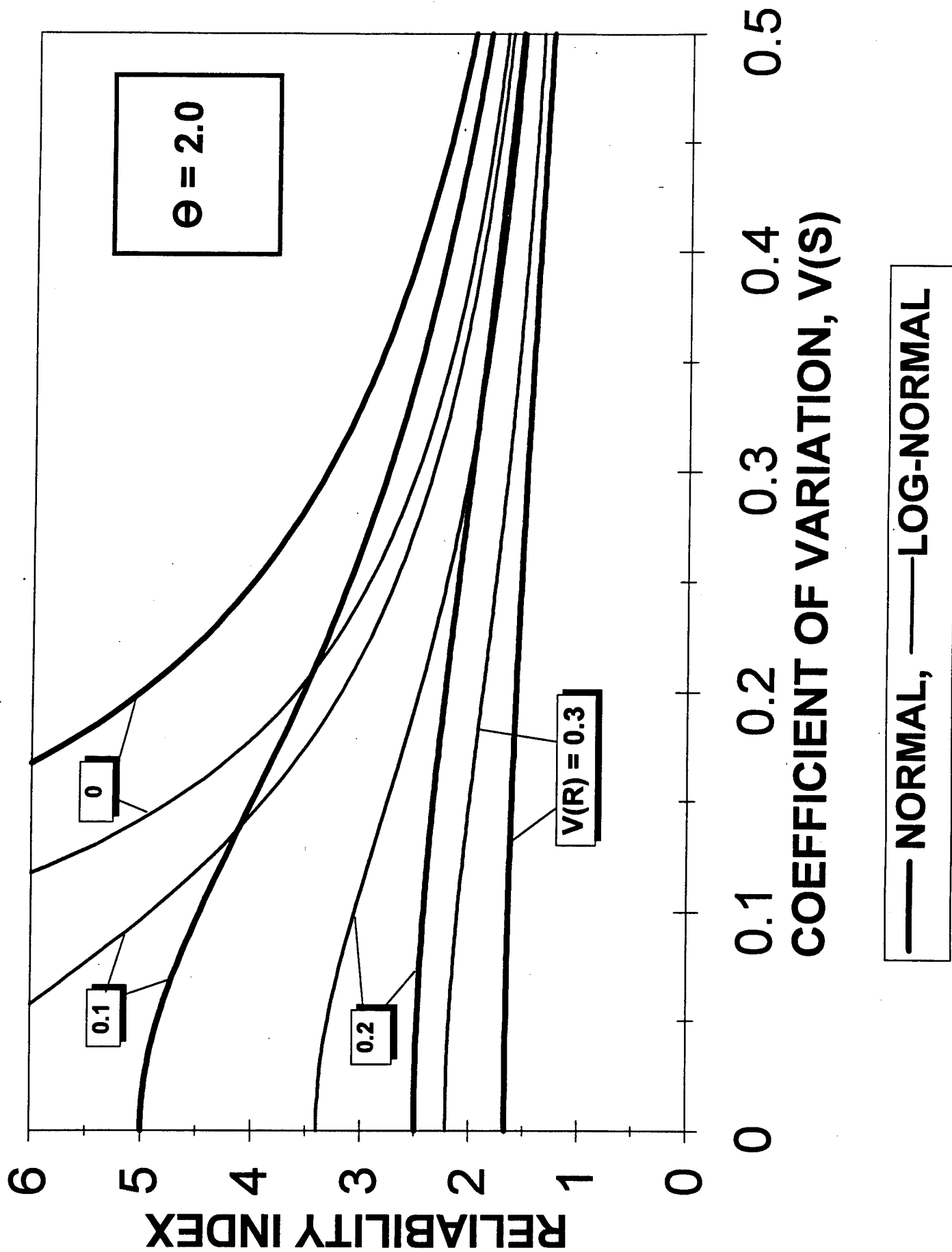

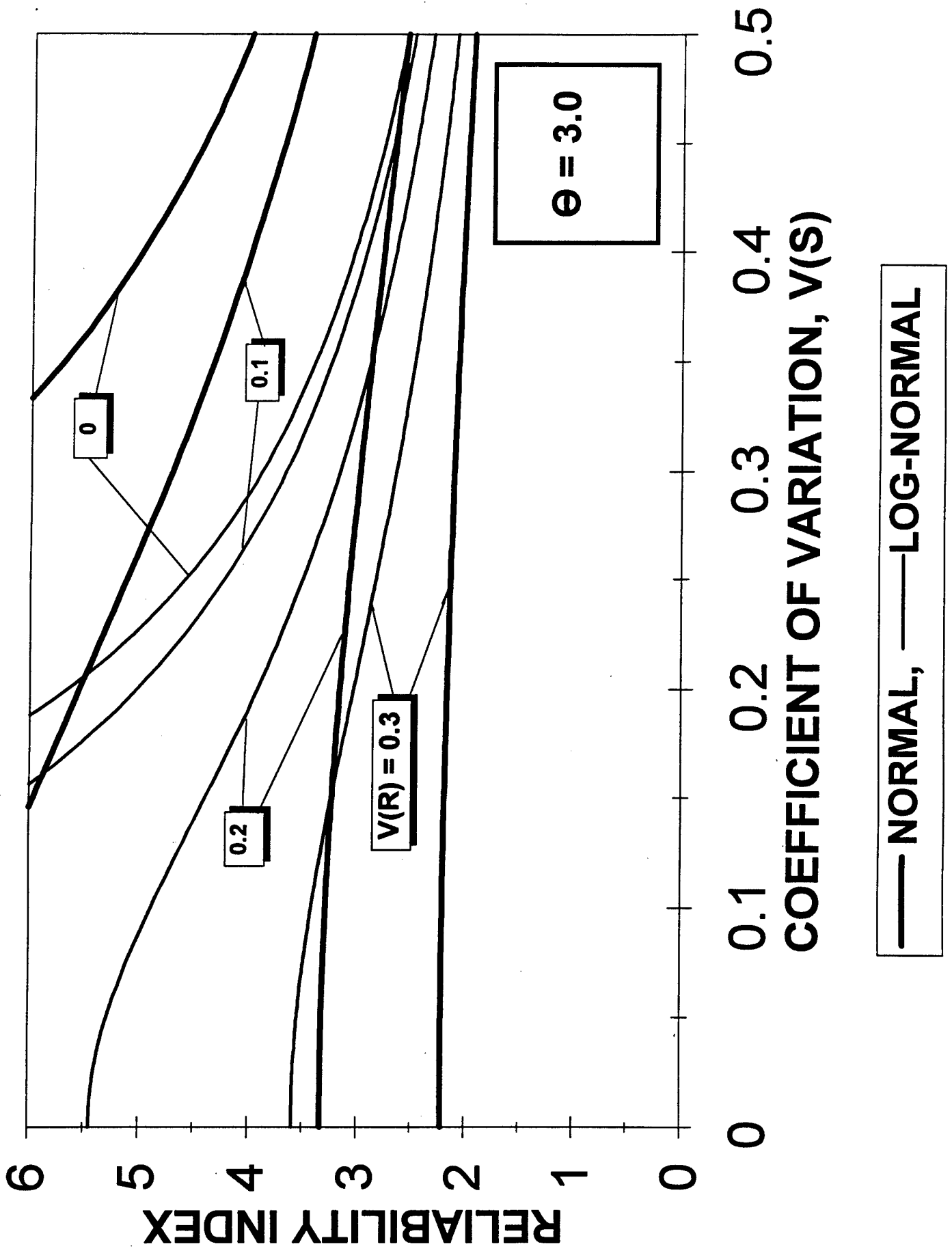

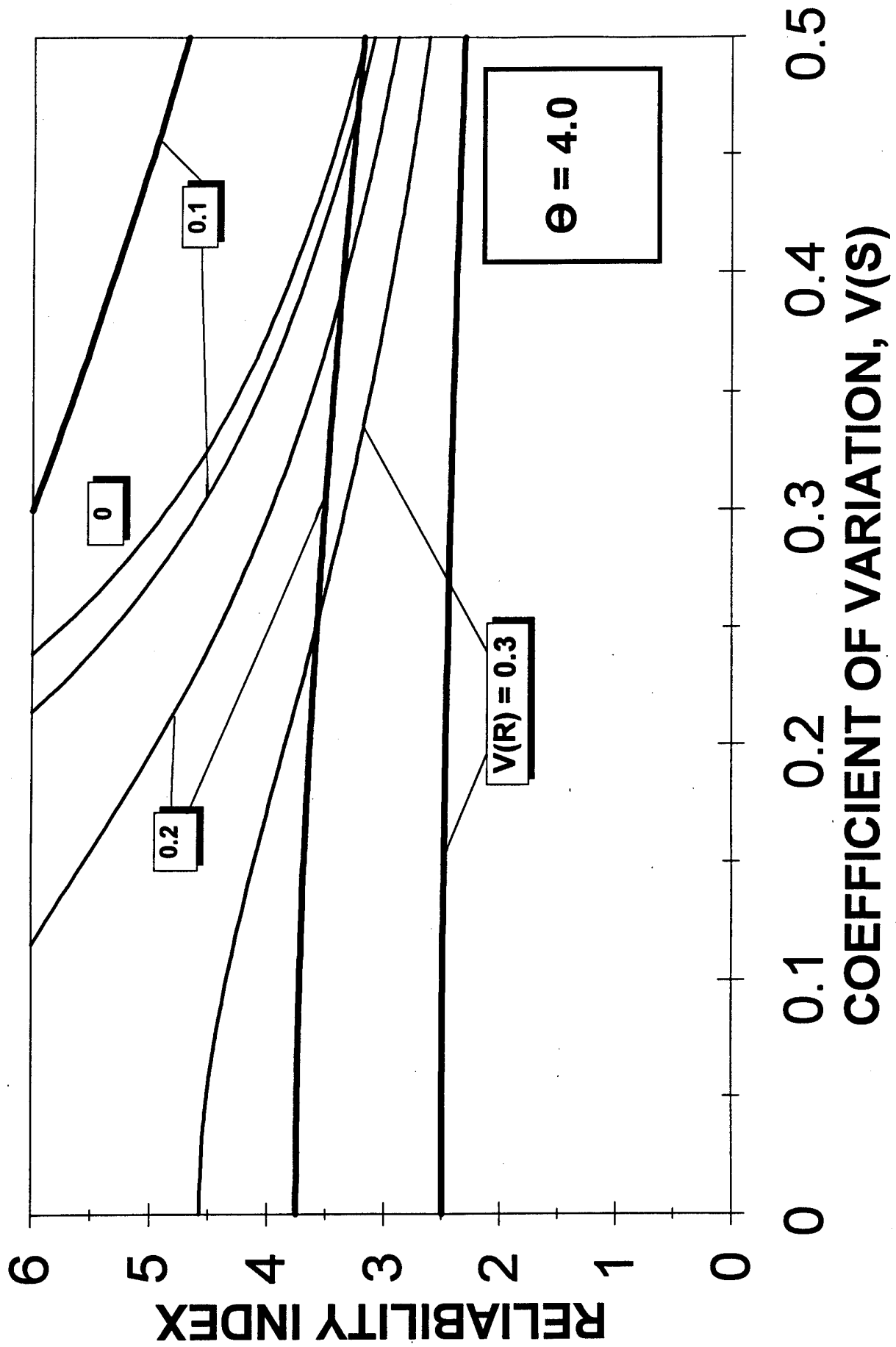

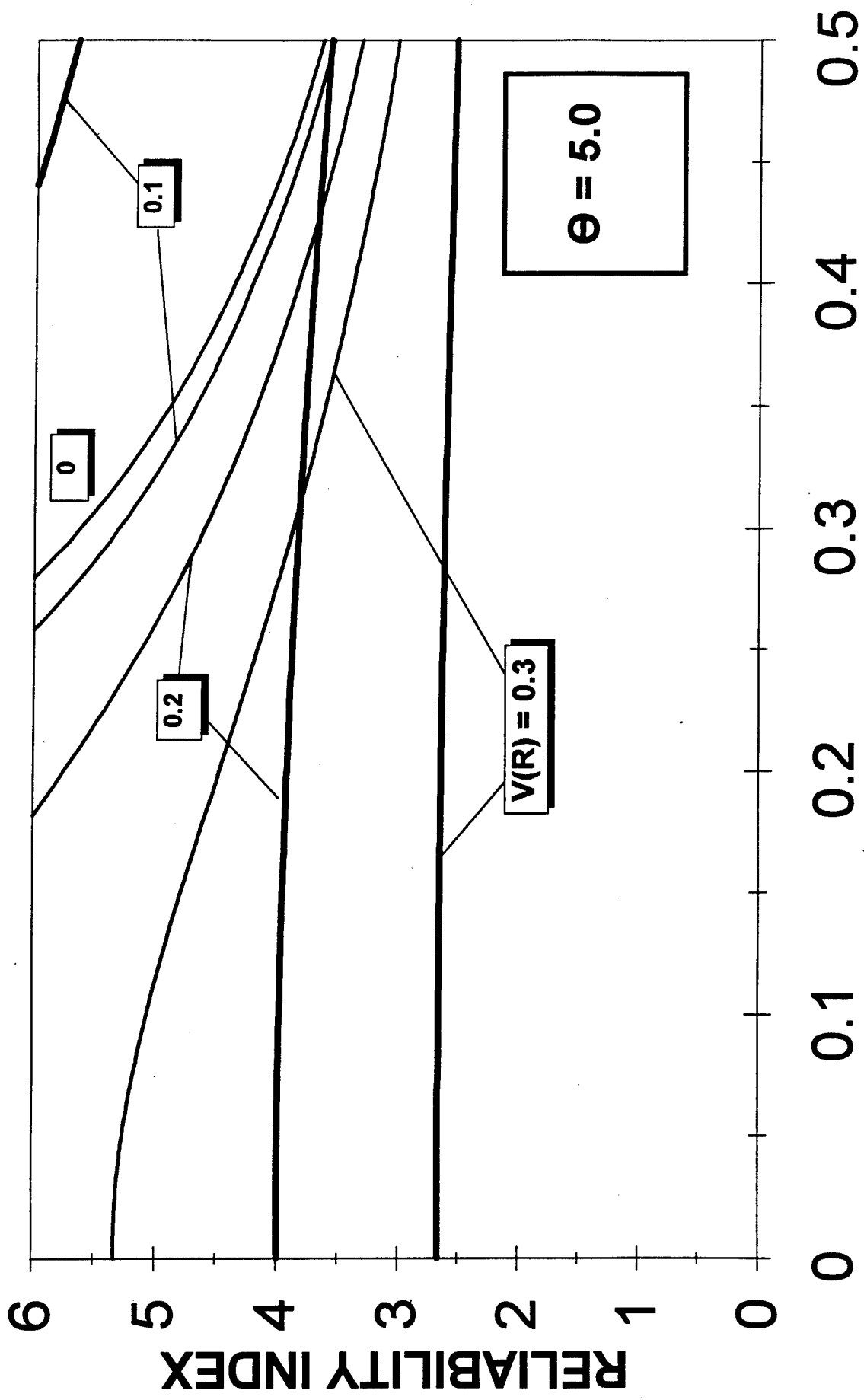

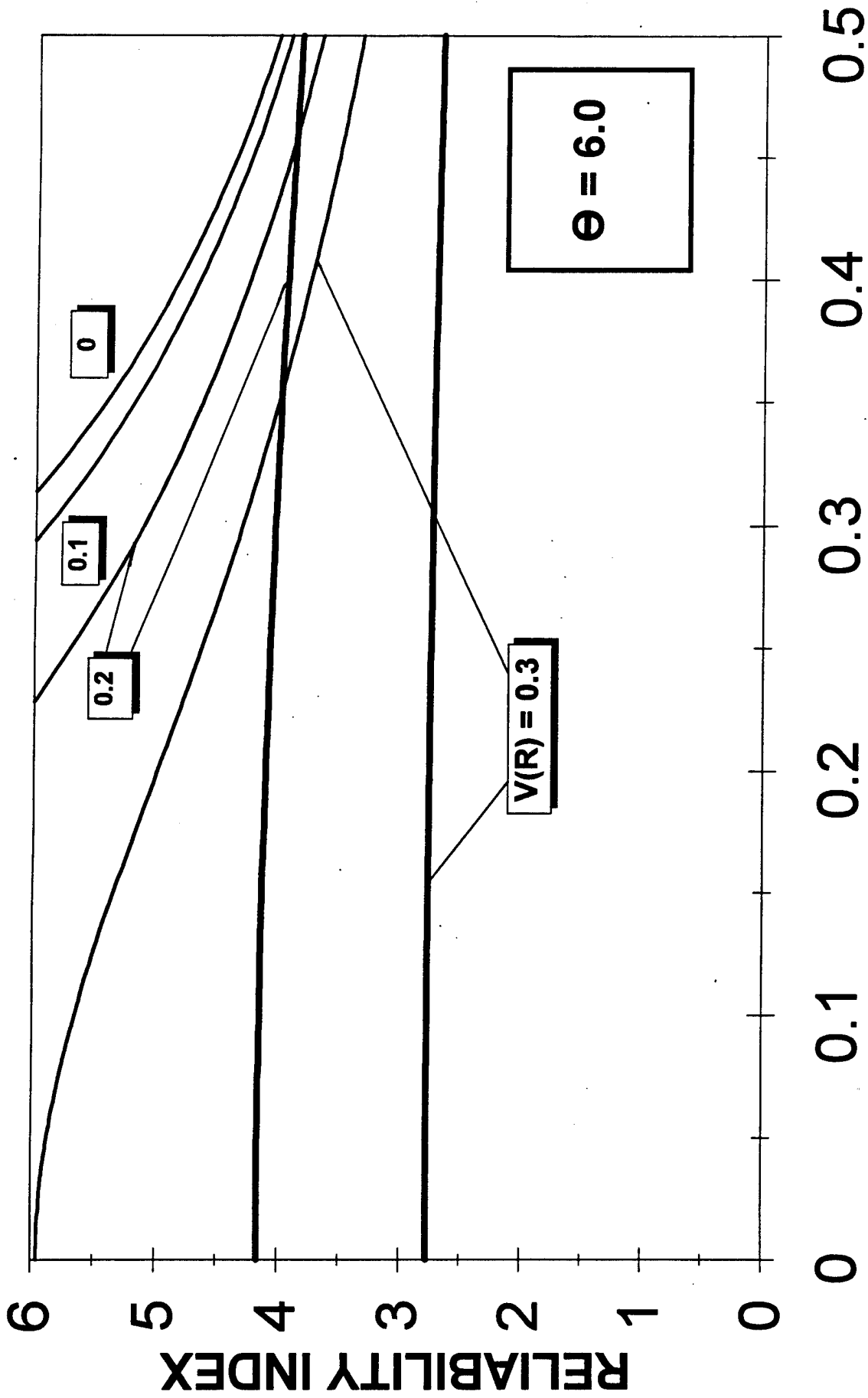

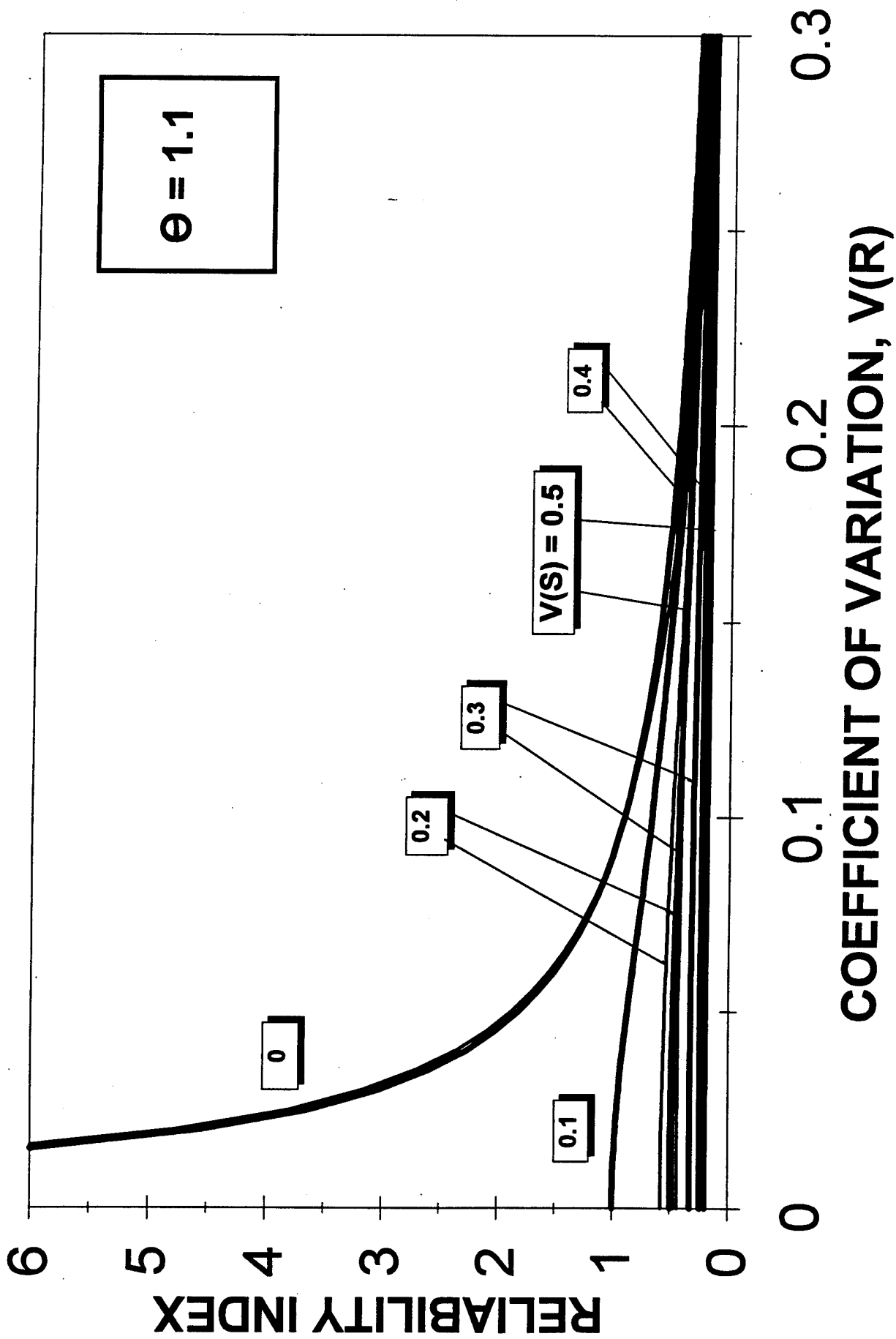

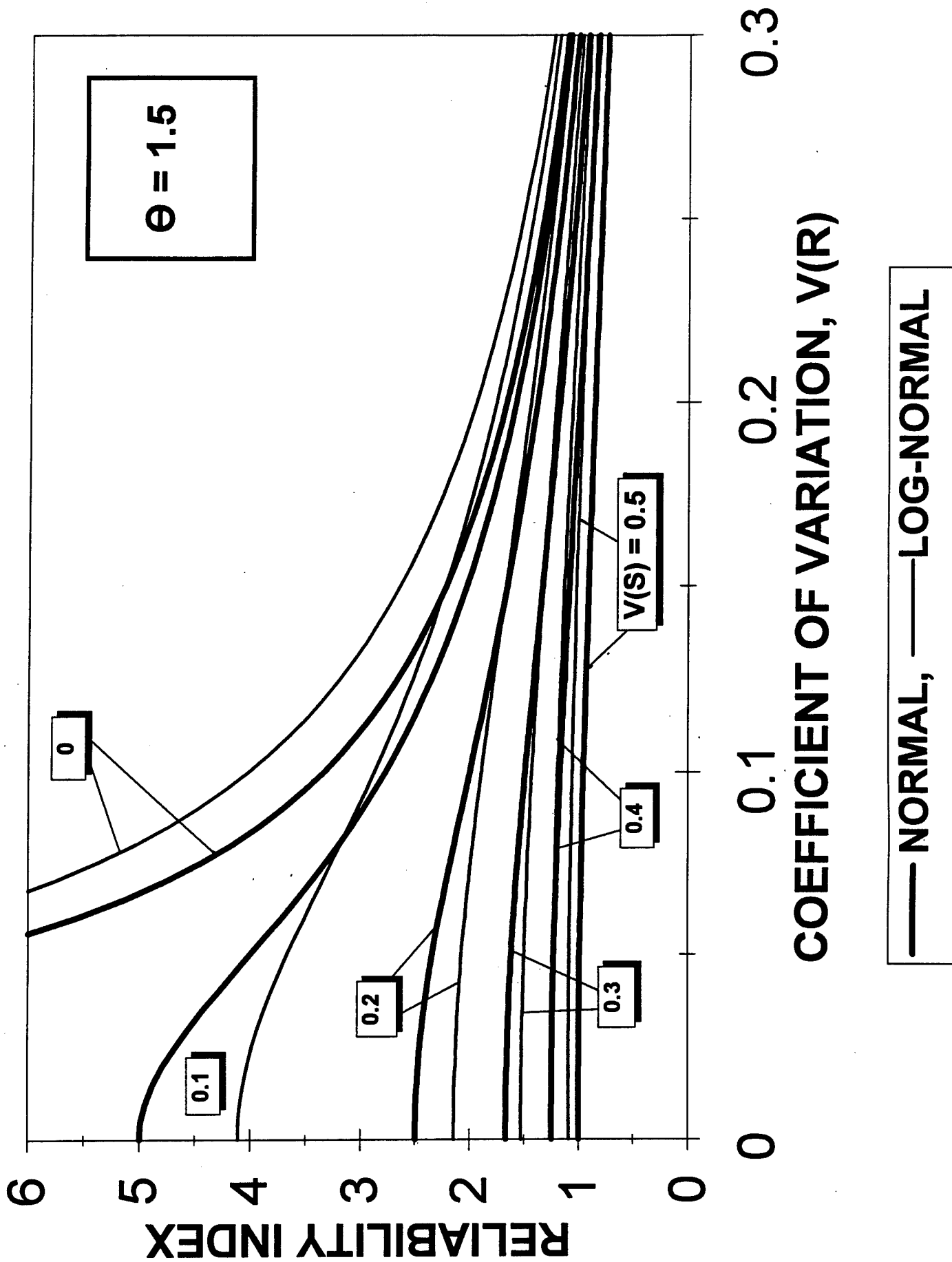

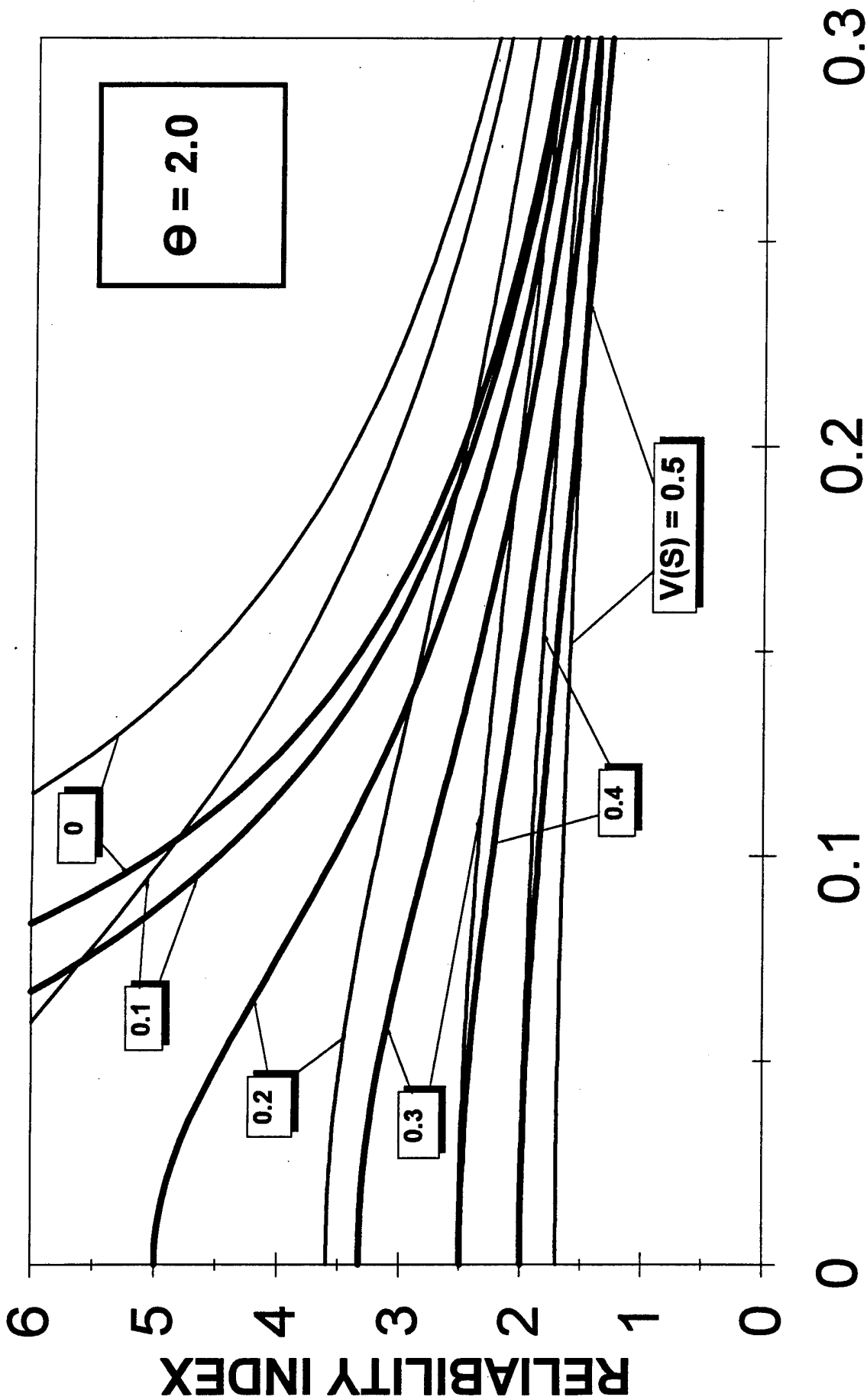

COEFFICIENT OF VARIATION, $V(R)$

— NORMAL, - - - LOG-NORMAL

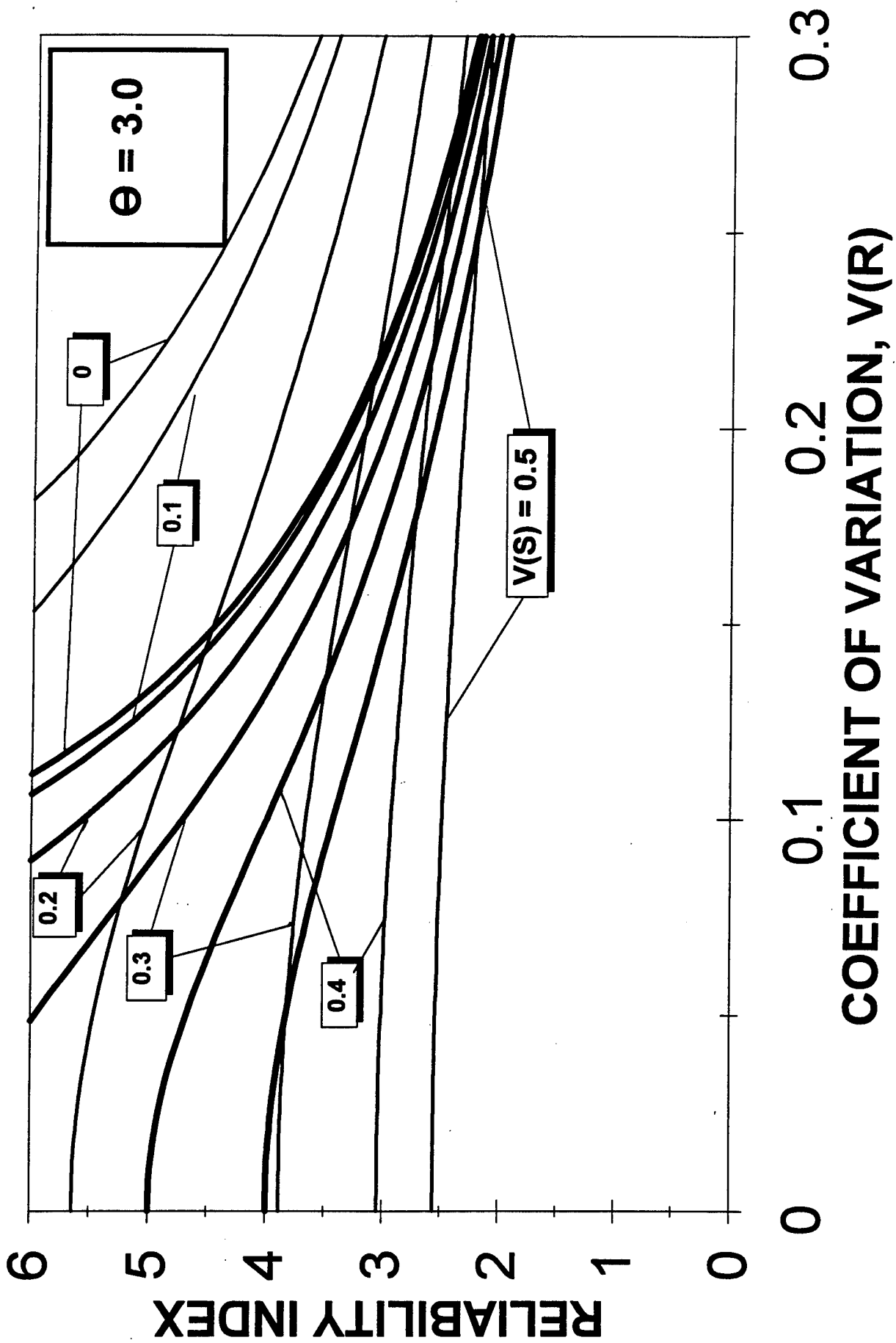

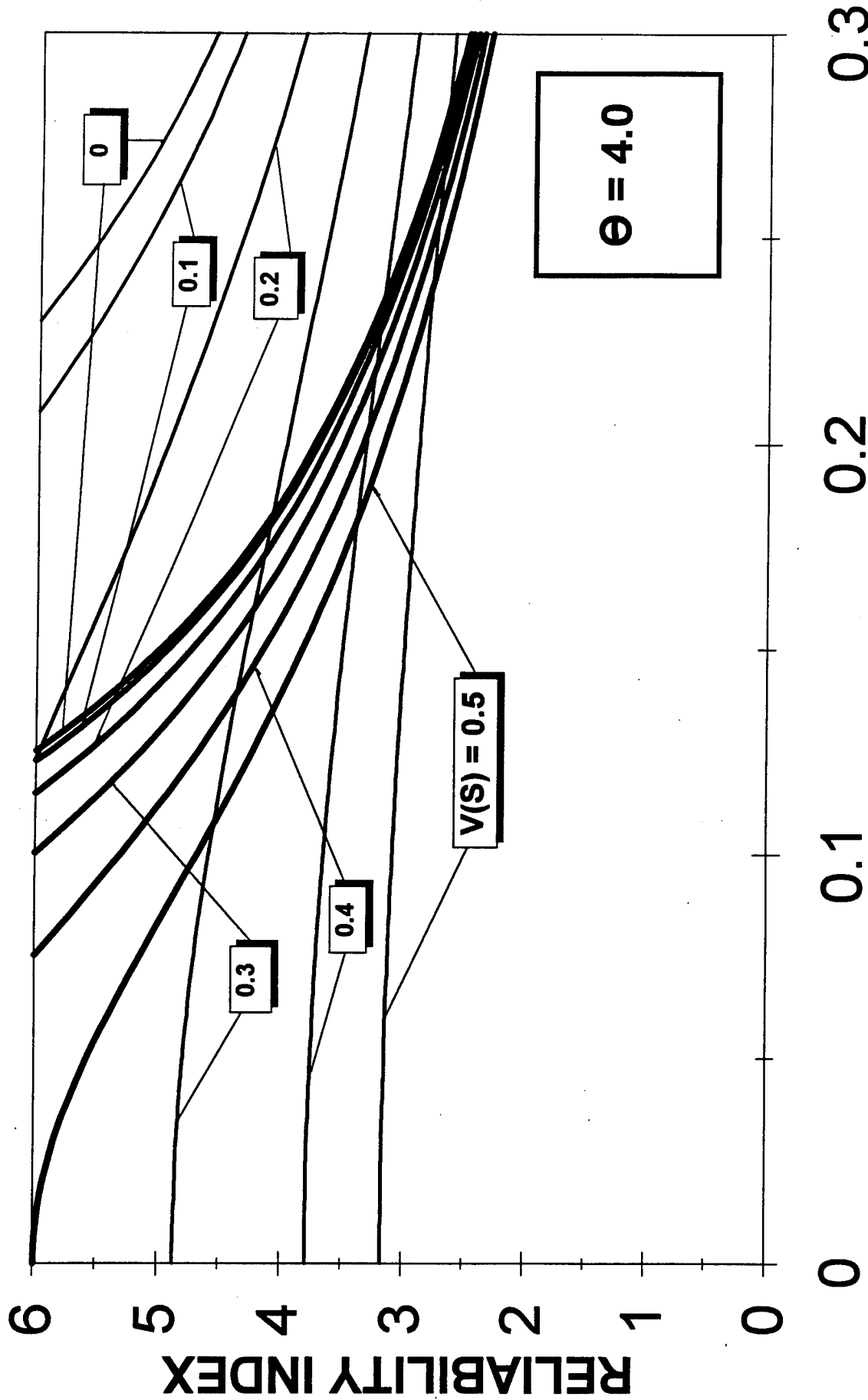

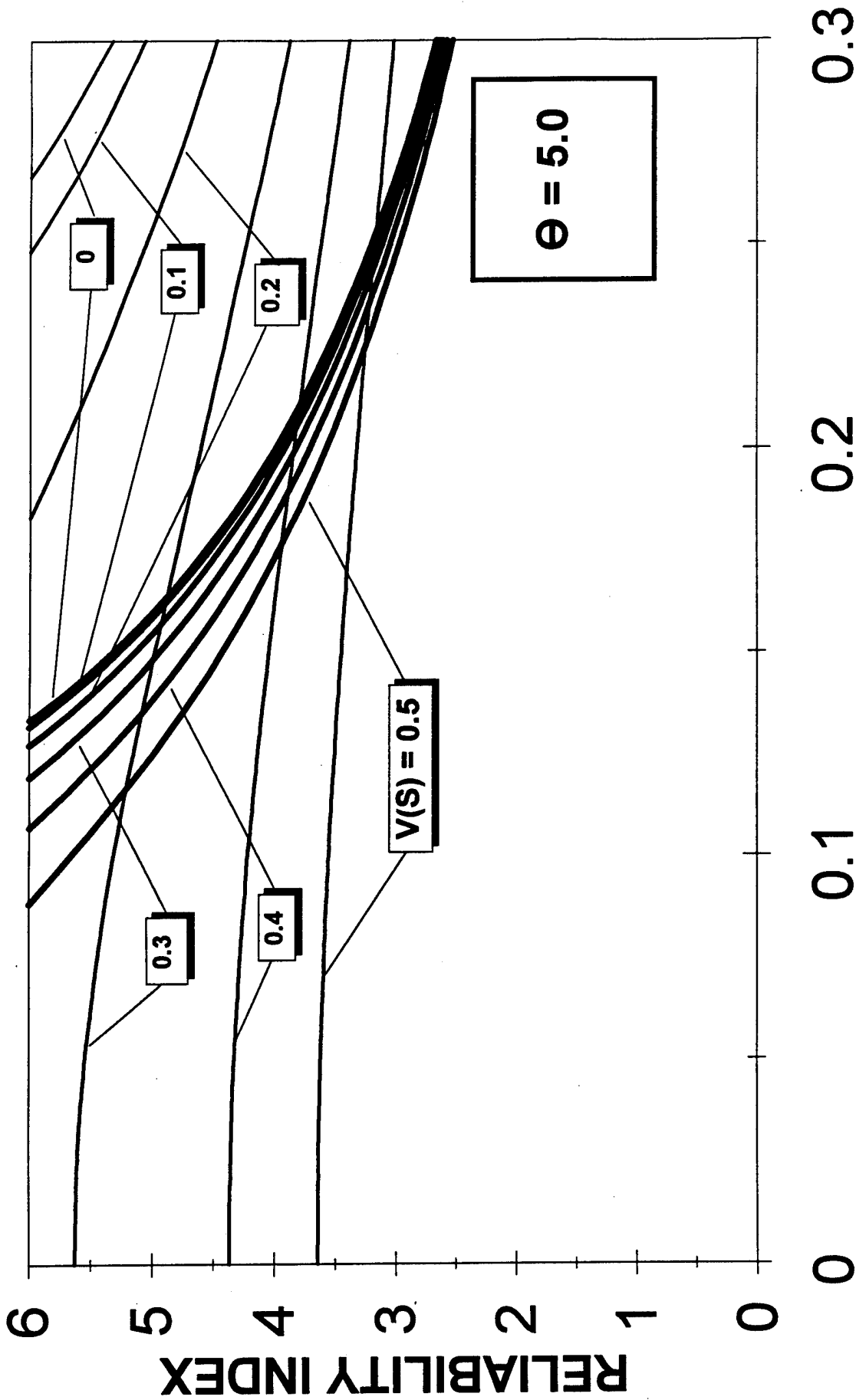

COEFFICIENT OF VARIATION, $V(R)$

— NORMAL, — LOG-NORMAL

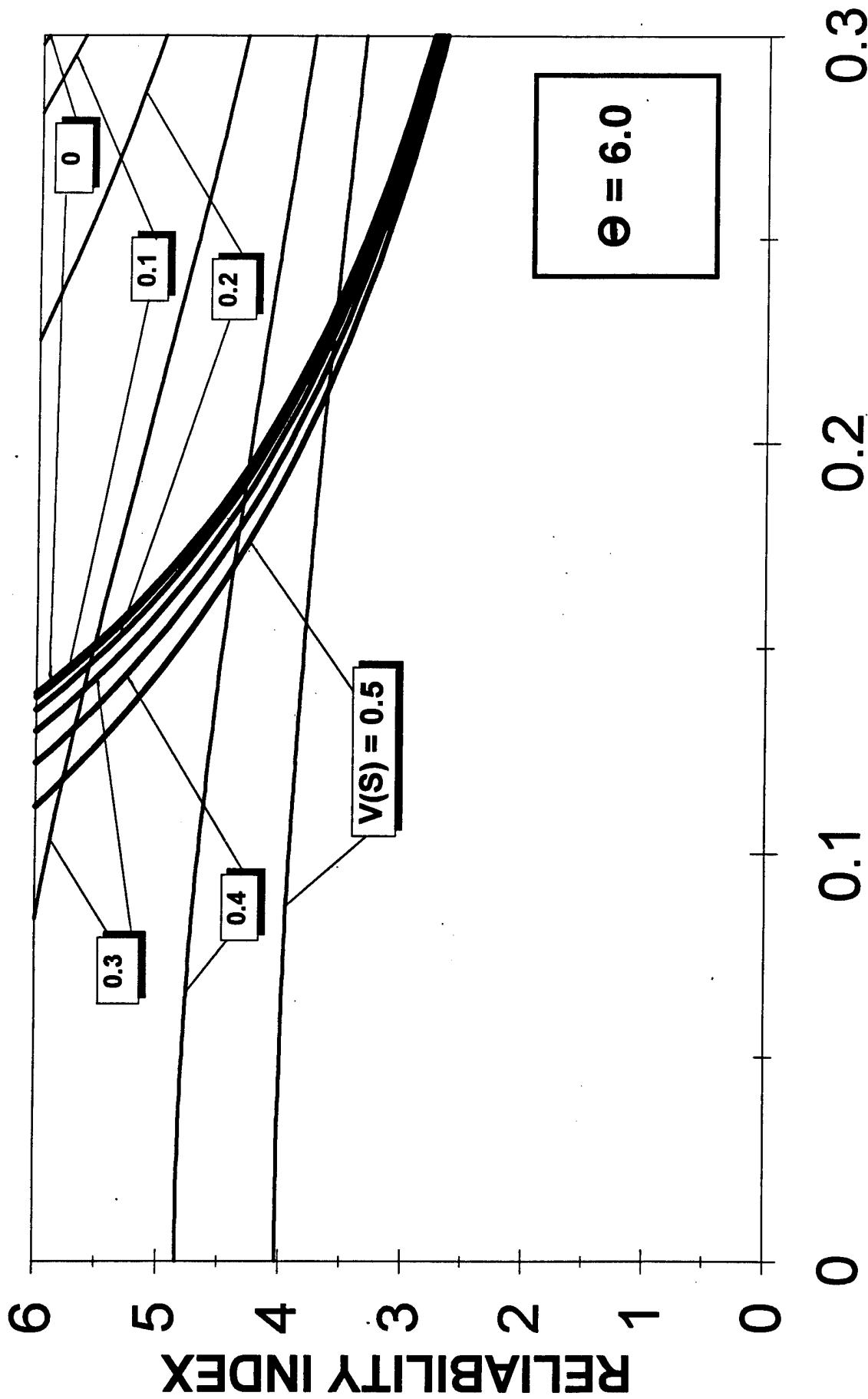

Appendix A

A2

Reliability Interaction Charts Compare Reliability Index vs Safety Factor

	β vs Θ ₀	β vs Θ ₀
Function	β	β
<i>Selected Variable</i>	V(R)	V(S)
<i>Discrete Variable</i>	V(S)	V(R)
<i>Continuous Variable</i>	Θ ₀	Θ ₀

Cases

Normal Variates A2.1-1 → A2.1-10

Log-Normal Variates A2.2-1 → A2.2-10

Comparison of Variates. A2.3-1 → A2.3-10

Function	0 ≤ β ≤ 6	all charts
<i>Variables</i> Select each V(R) Display all V(S), Θ ₀	V(R): 0, 0.1, 0.2, 0.3 V(S): 0, 0.1, 0.2, 0.3, 0.4, 0.5 1.1 ≤ Θ ₀ ≤ 6.0	both cases <i>f{V(R), V(S), Θ₀}</i> type
Select each V(S) Display all V(R), Θ ₀	V(S): 0, 0.1, 0.2, 0.3, 0.4, 0.5 V(R): 0, 0.1, 0.2, 0.3 1.1 ≤ Θ ₀ ≤ 6.0	both cases <i>f{V(S), V(R), Θ₀}</i> type

Reliability equations developed from root form. (Ang and Cornell, p. 1756)

$$\beta_{Normal} = \frac{\Theta_0 - 1}{\sqrt{V_R^2 \Theta_0 + V_S^2}} \qquad \beta_{Log-Normal} = \frac{\ln \left[\Theta_0 \sqrt{\frac{1 + V_S^2}{1 + V_R^2}} \right]}{\sqrt{\ln \left[(1 + V_R^2) (1 + V_S^2) \right]}}$$

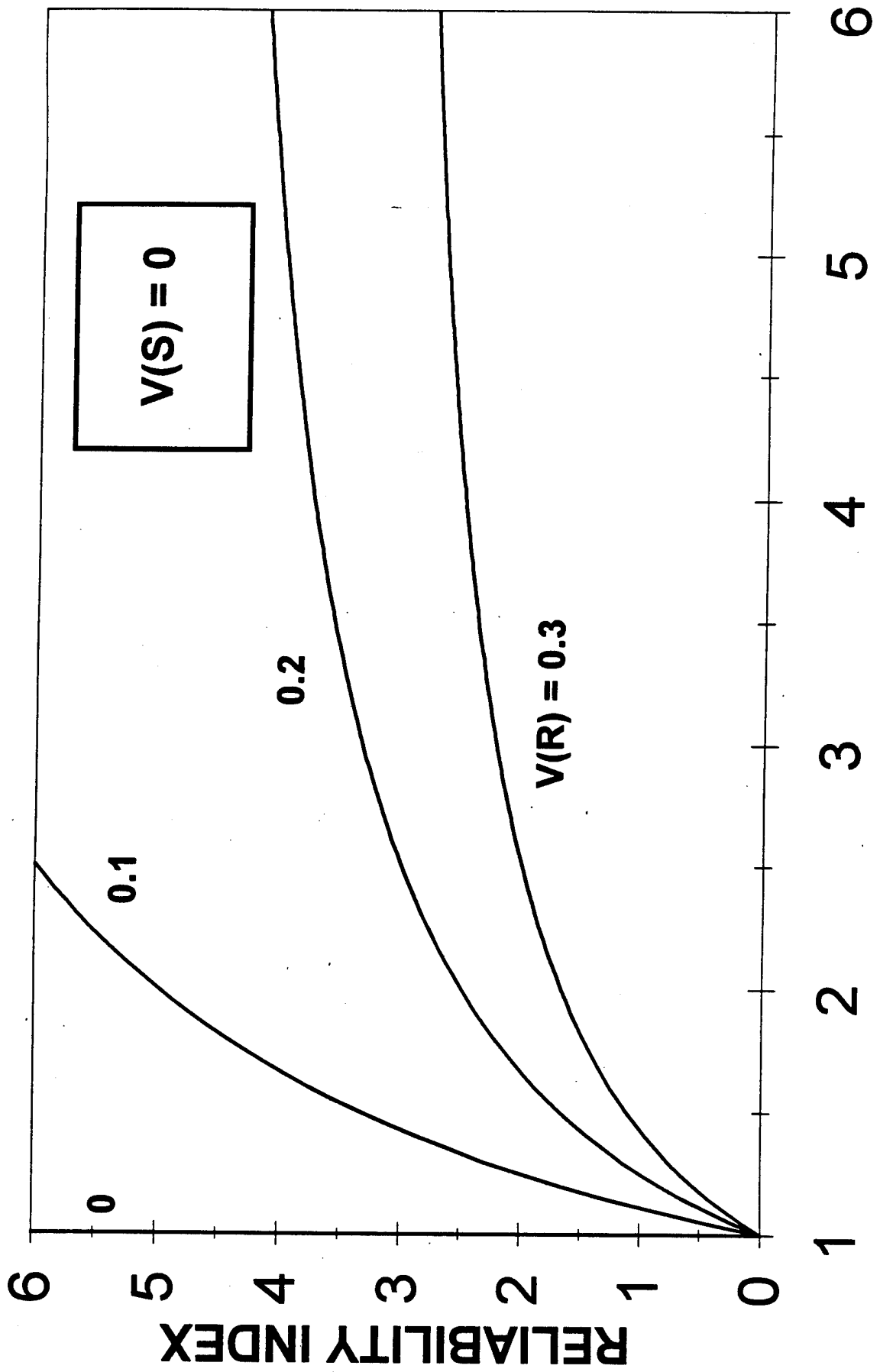

CENTRAL SAFETY FACTOR

R: NORMAL, S: NORMAL

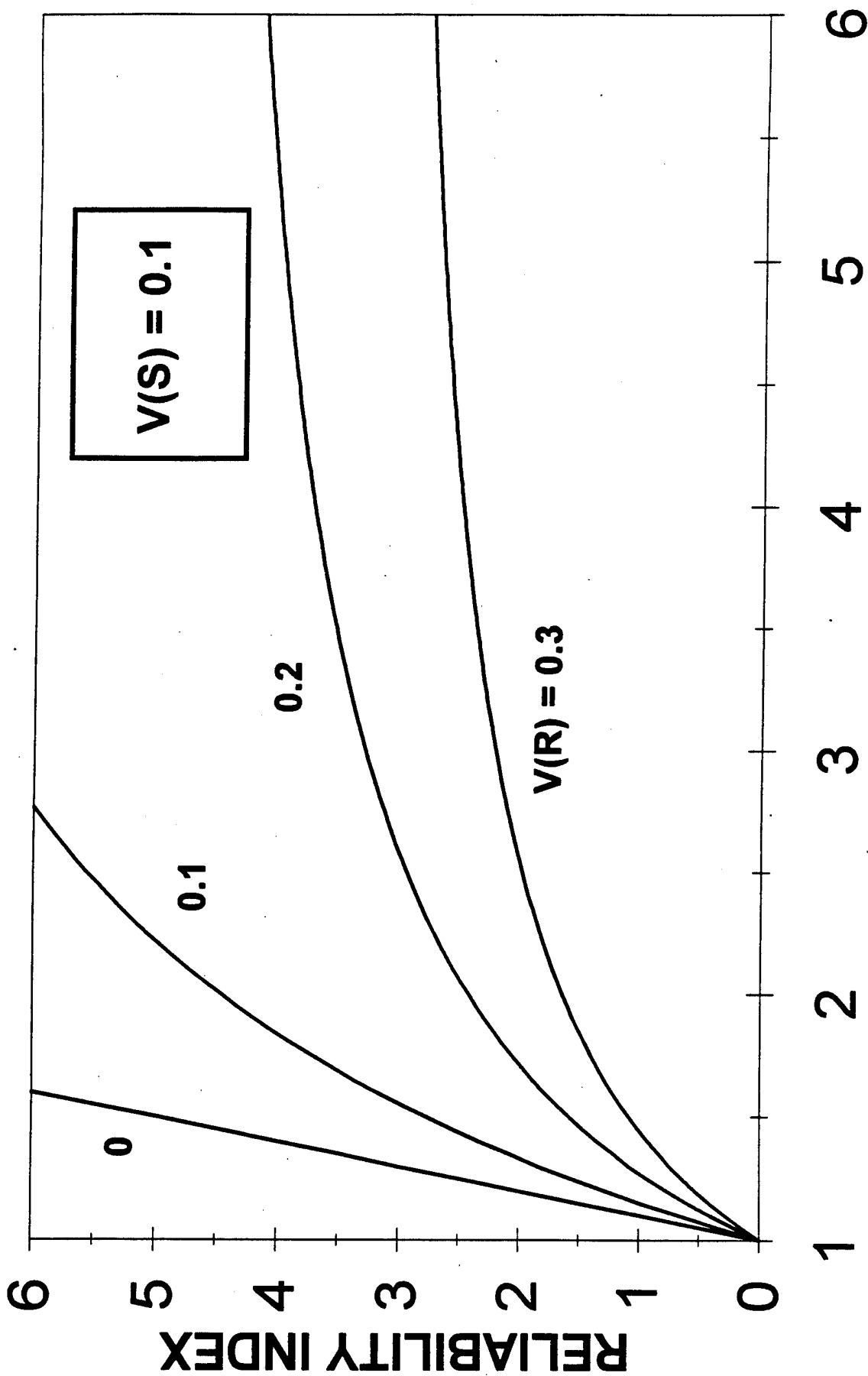

R: NORMAL, S: NORMAL

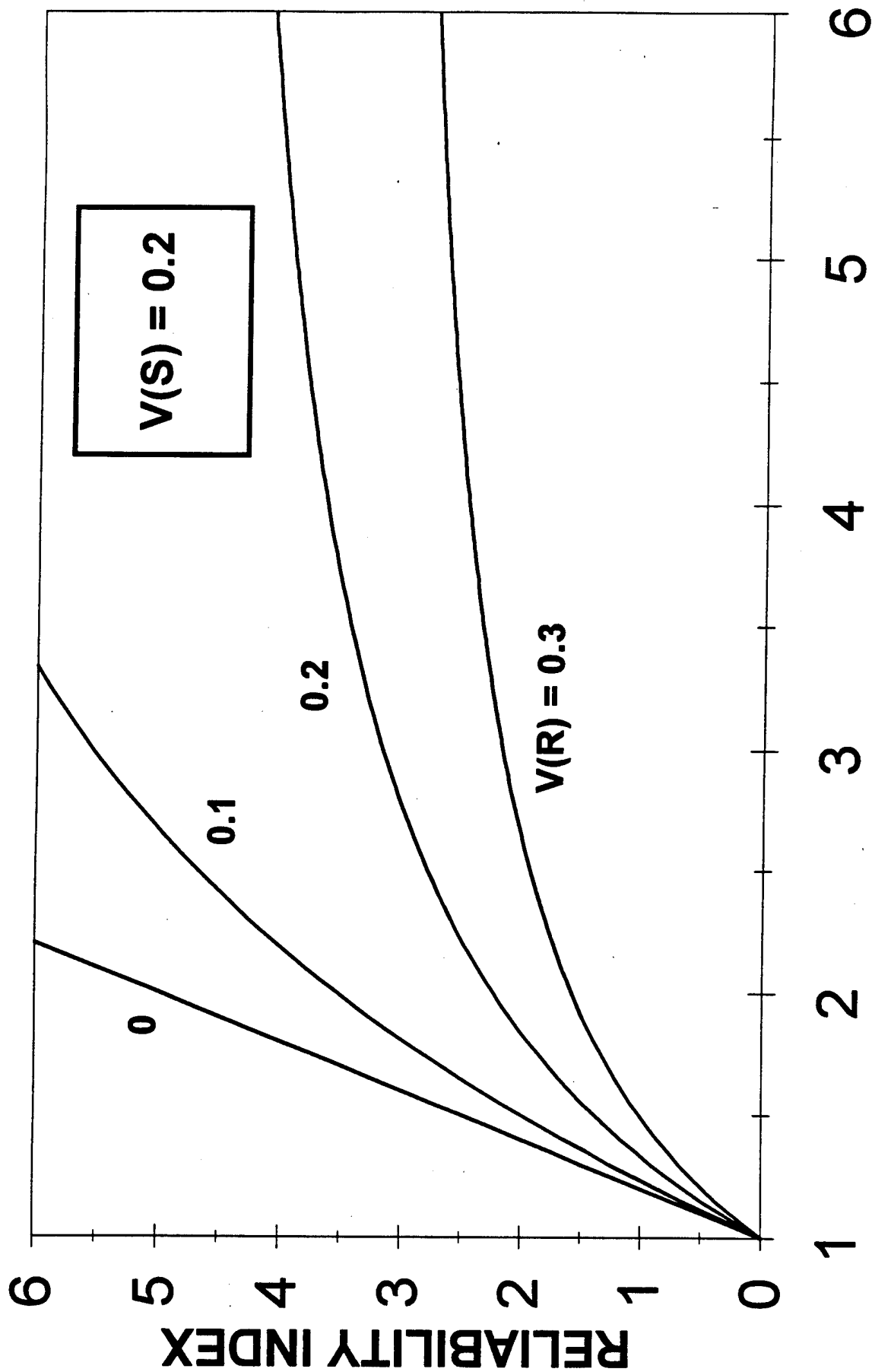

R: NORMAL, S: NORMAL

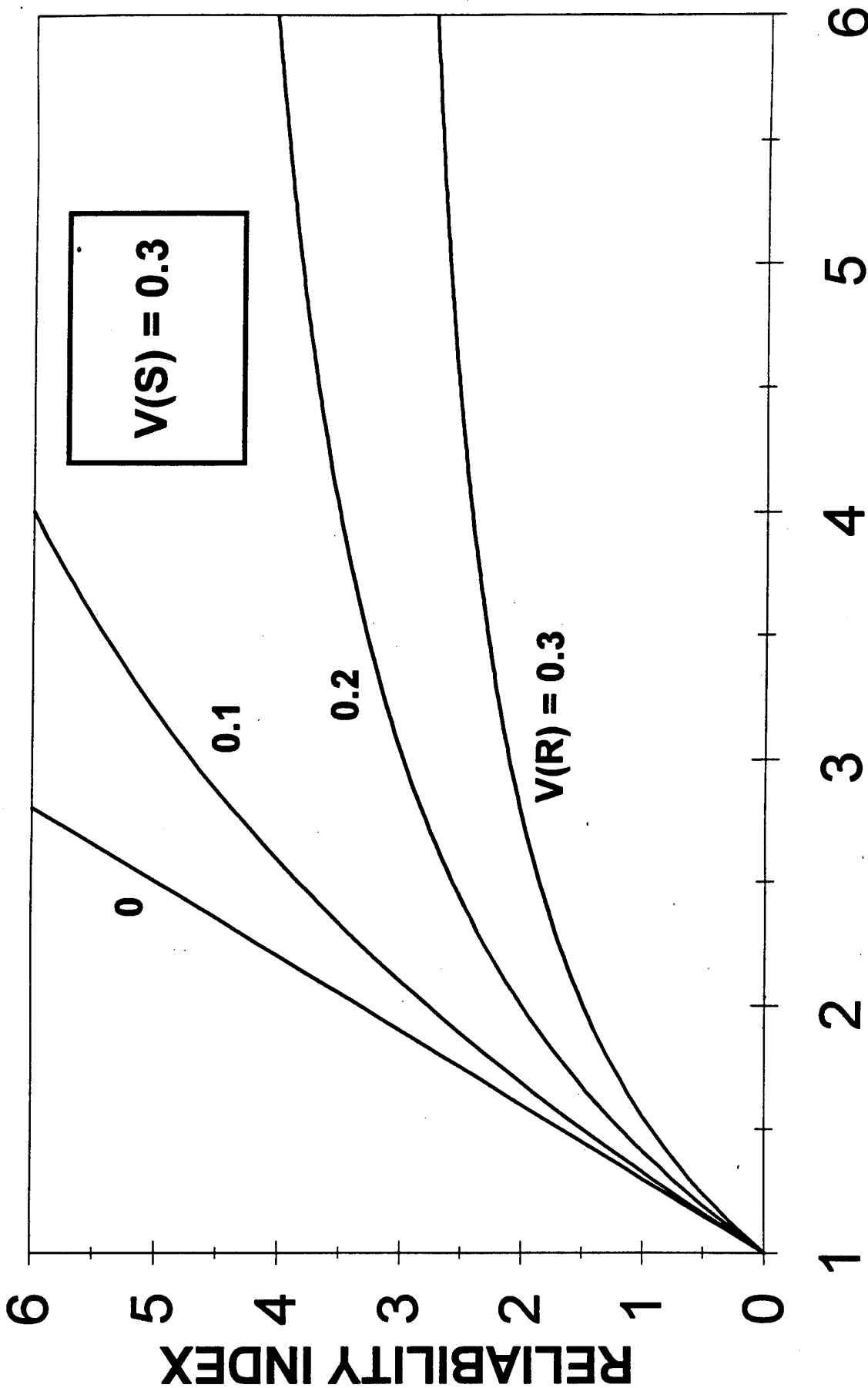

CENTRAL SAFETY FACTOR

R: NORMAL, S: NORMAL

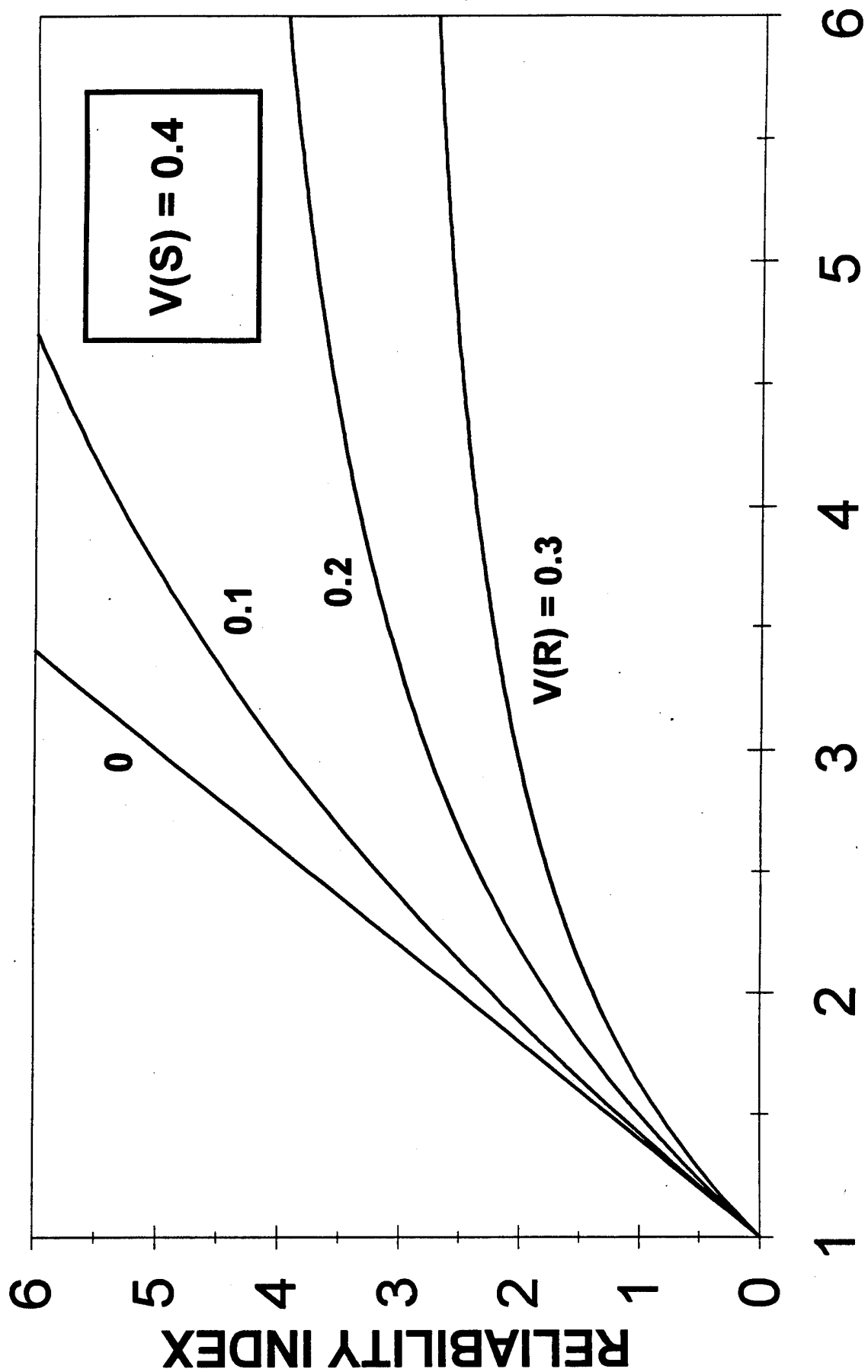

R: NORMAL, S: NORMAL

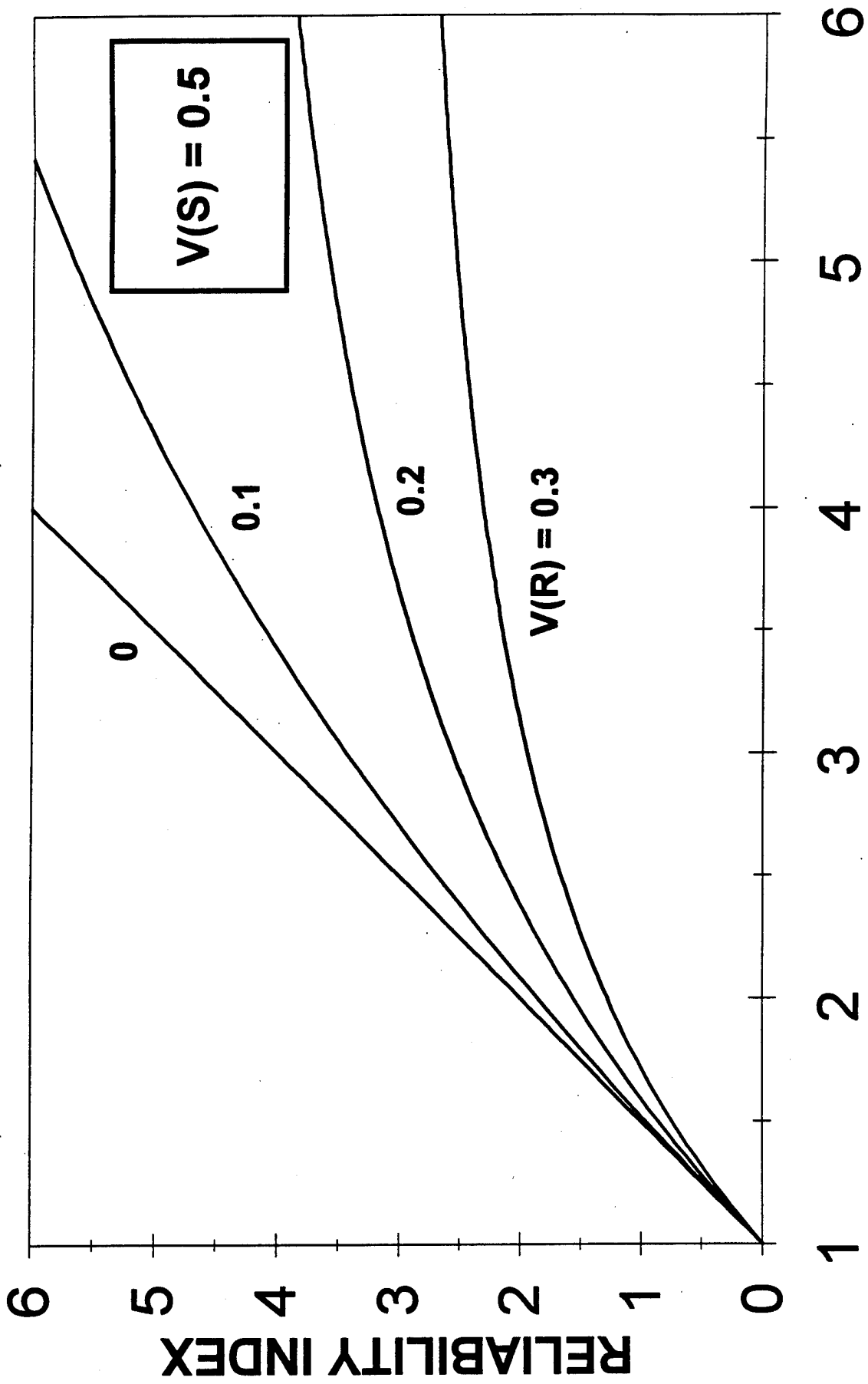

R: NORMAL, S: NORMAL

R: NORMAL, S: NORMAL

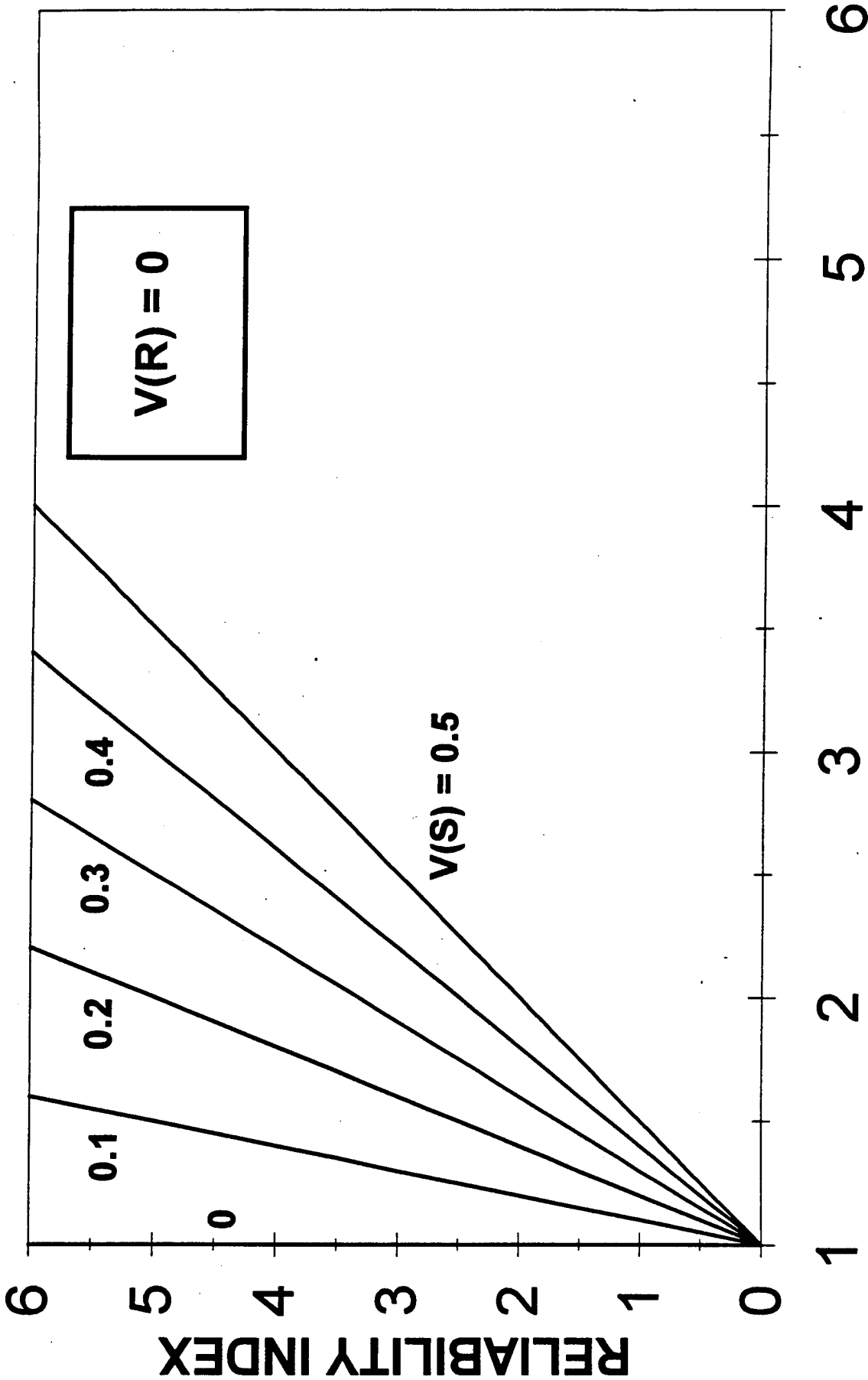

CENTRAL SAFETY FACTOR

R: NORMAL, S: NORMAL

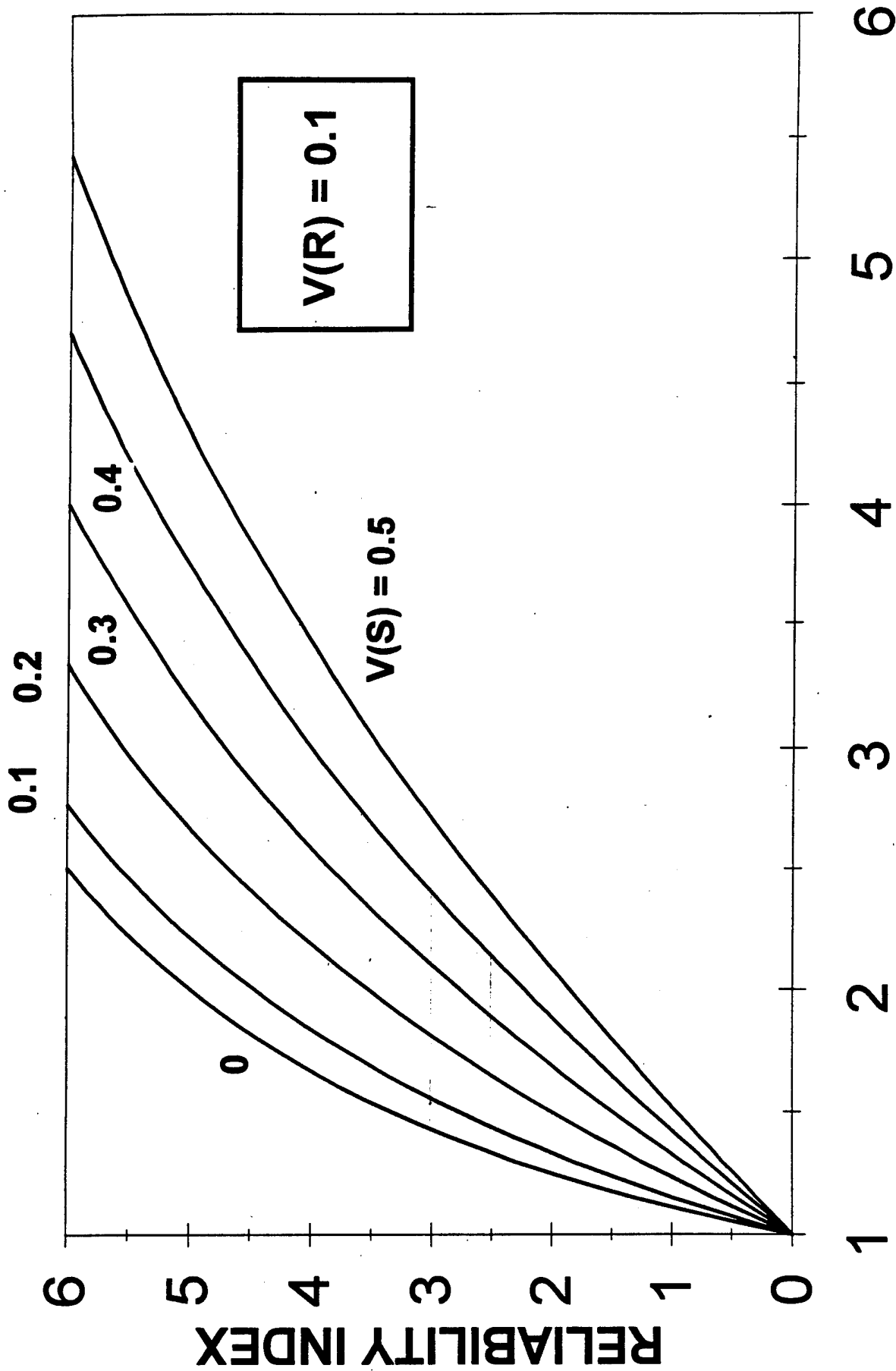

R: NORMAL, S: NORMAL

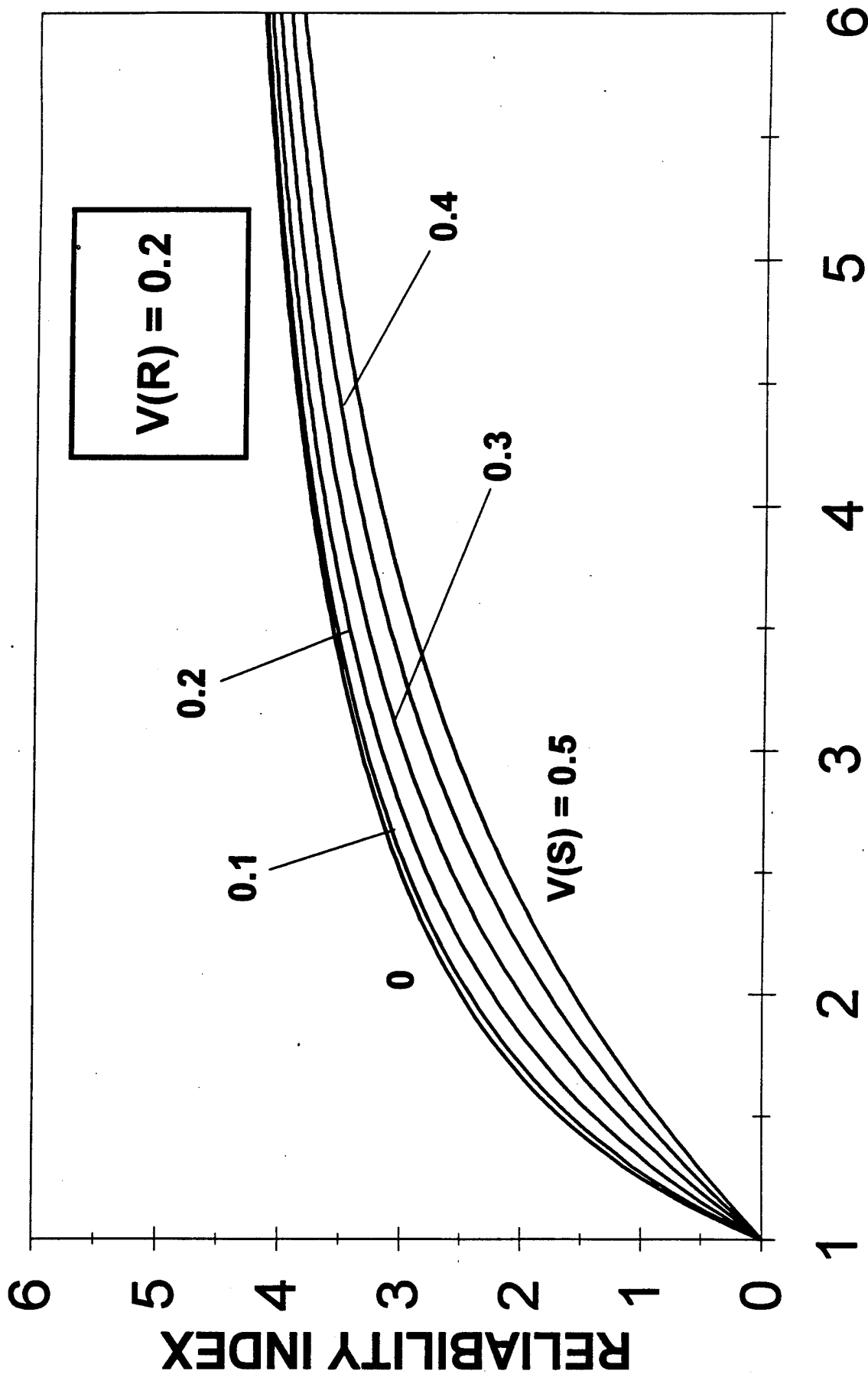

R: NORMAL, S: NORMAL

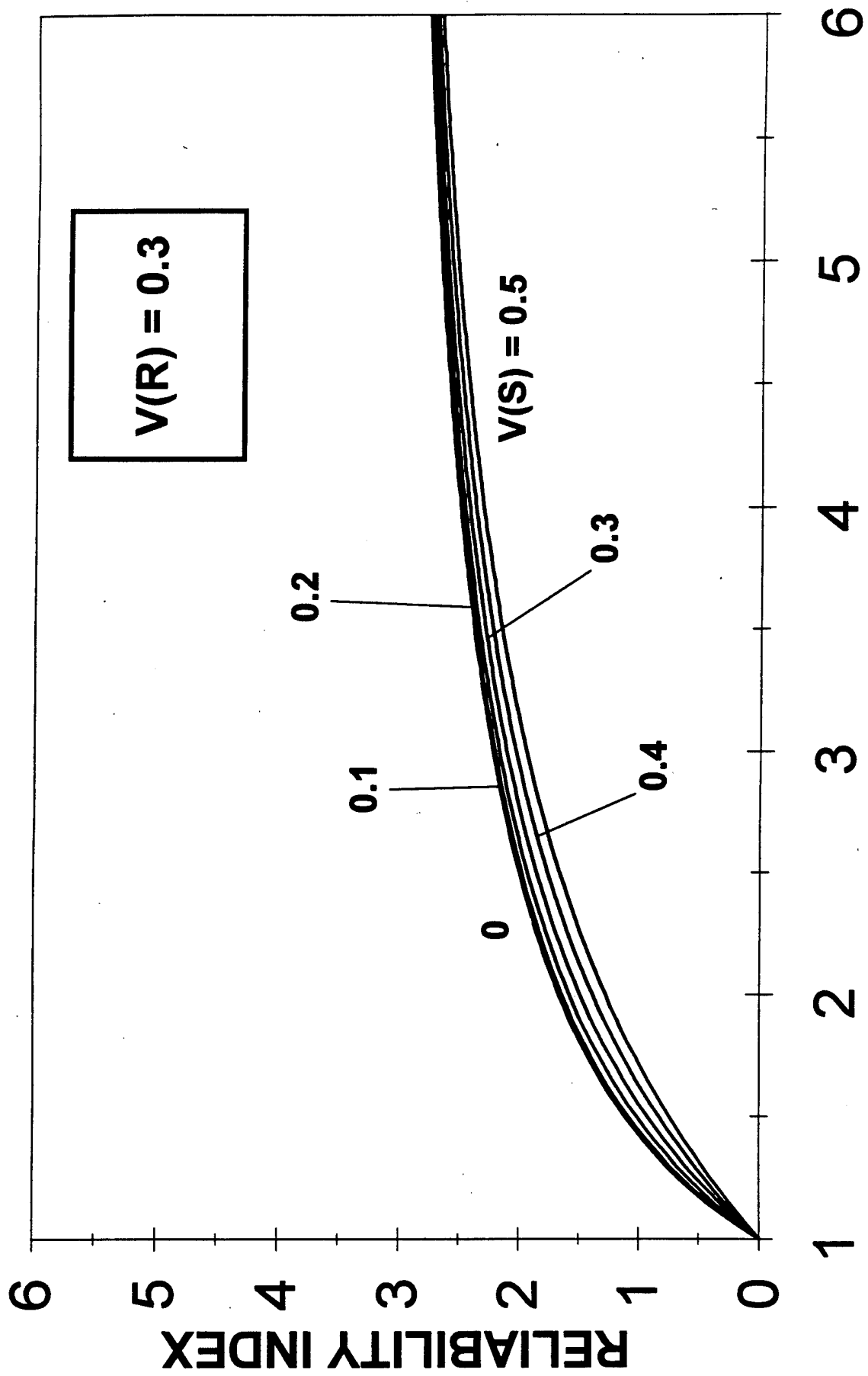

R: NORMAL, S: NORMAL

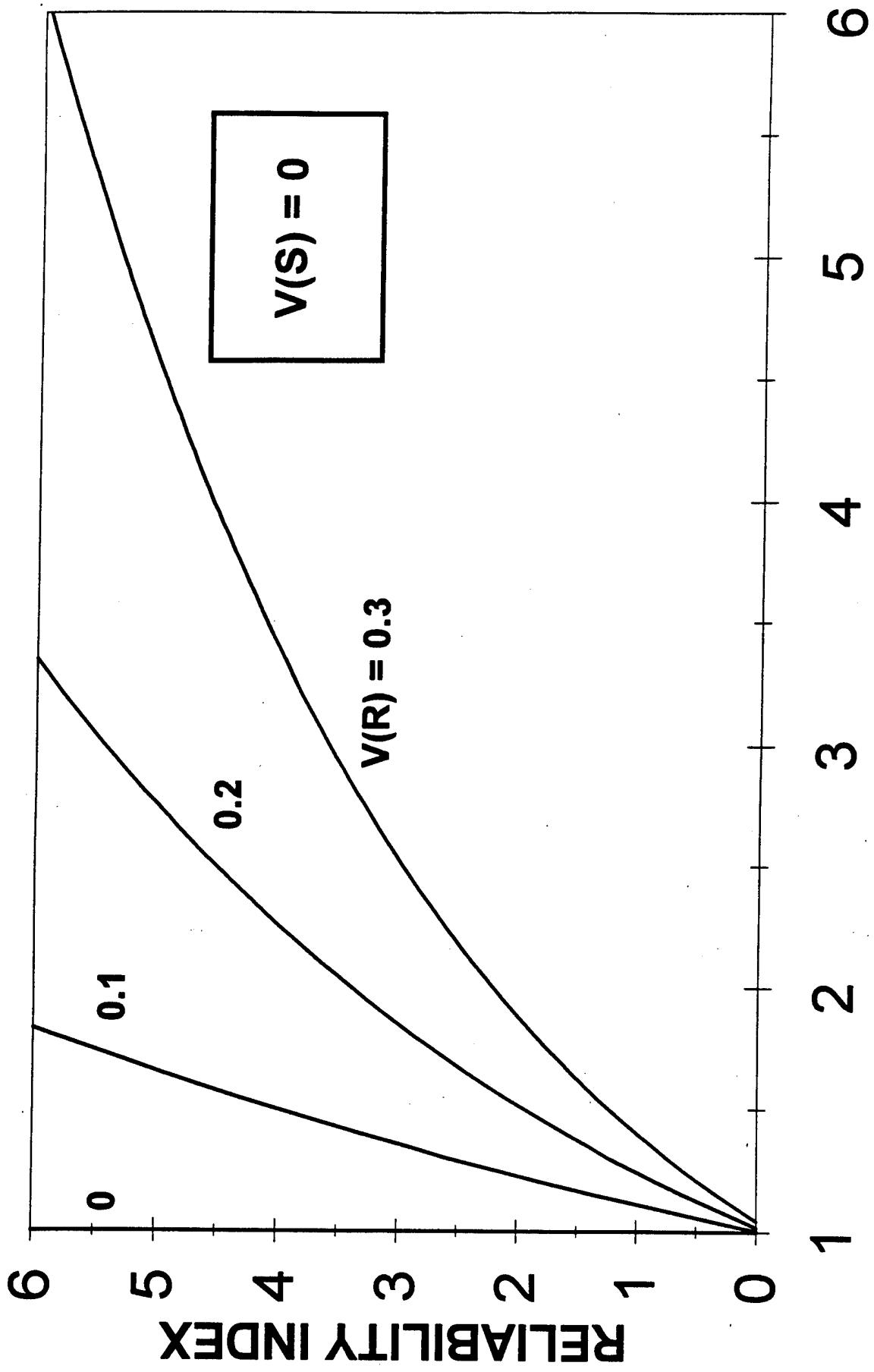

R: LOG-NORMAL, S: LOG-NORMAL

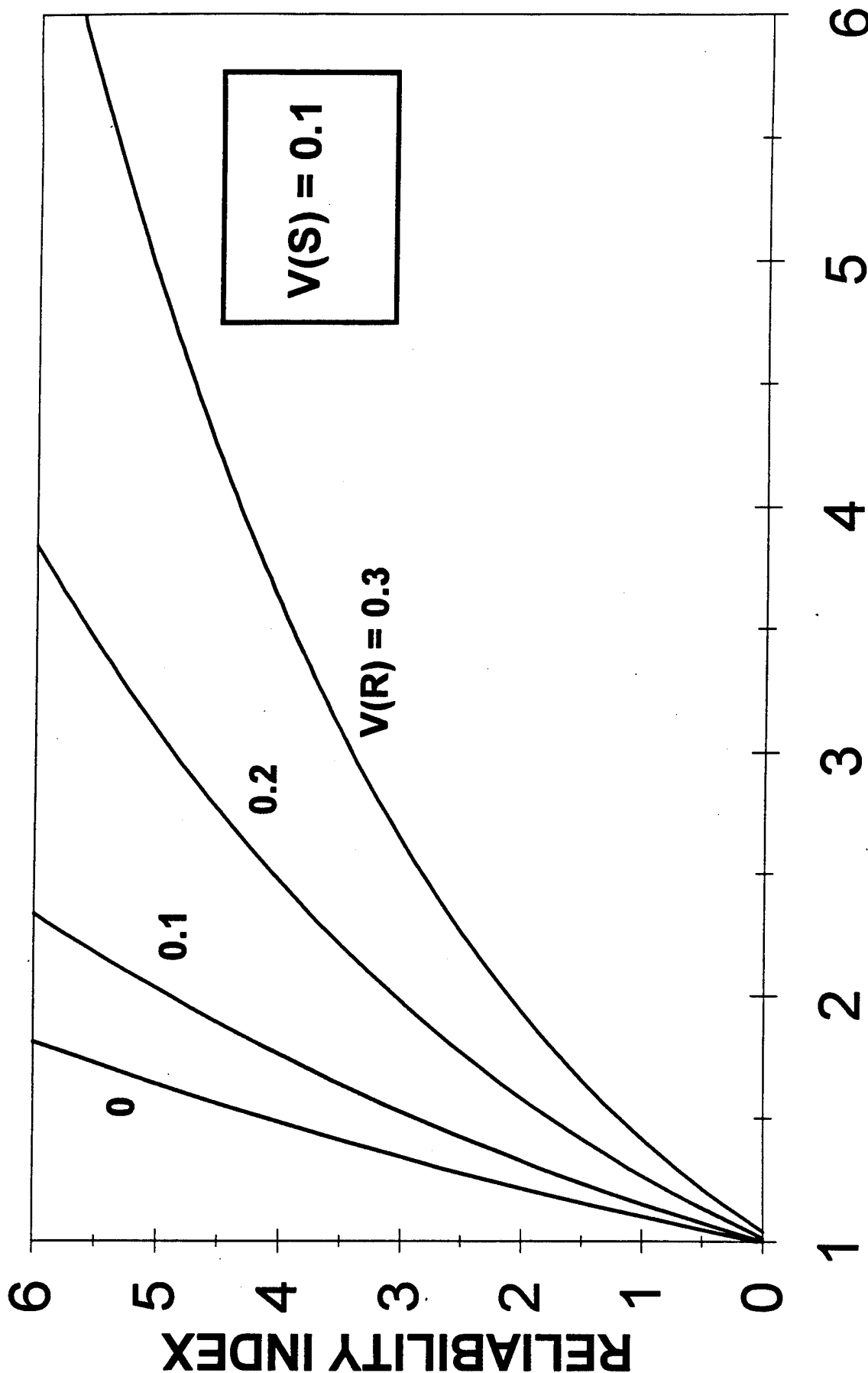

CENTRAL SAFETY FACTOR

R: LOG-NORMAL, S: LOG-NORMAL

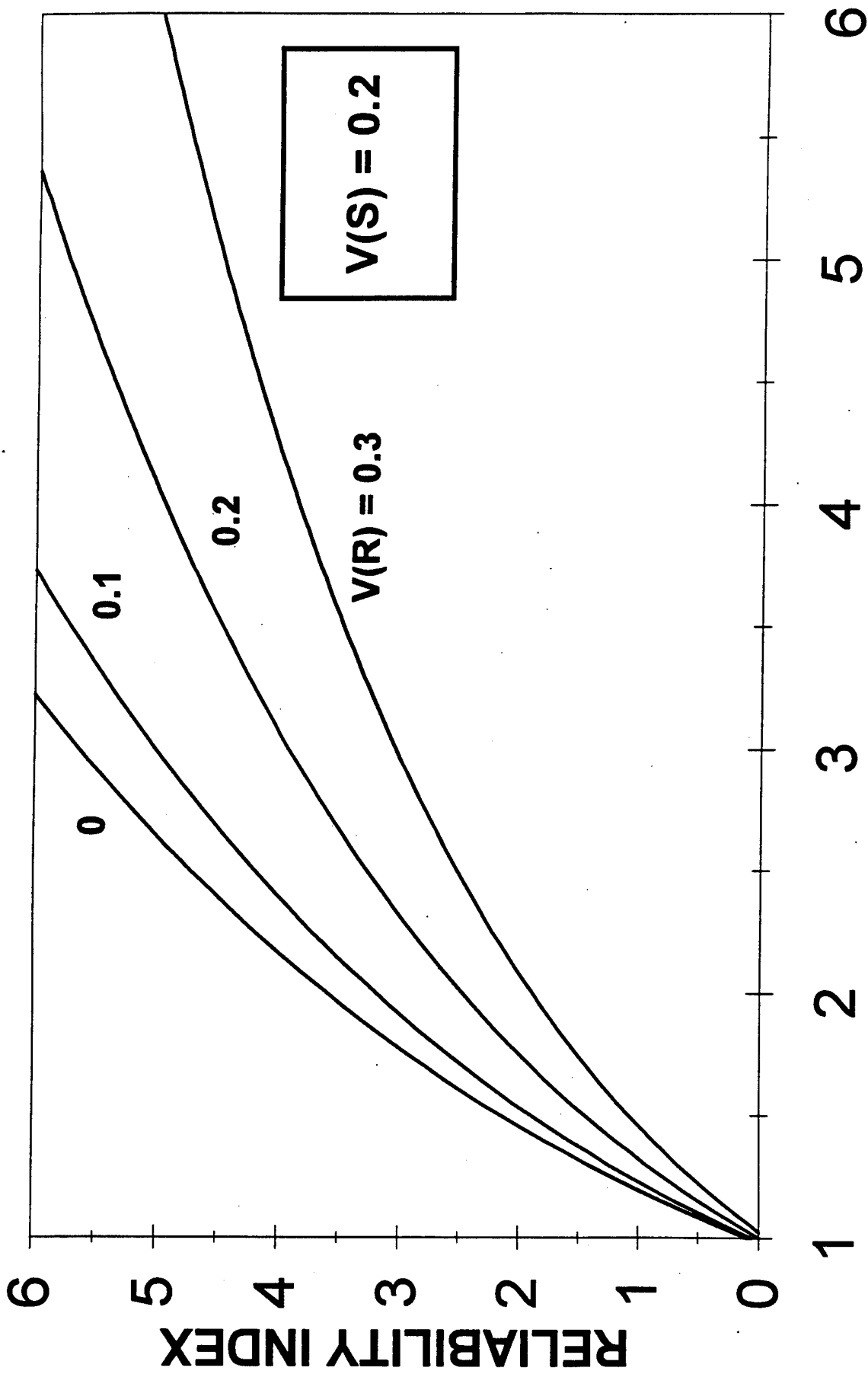

R: LOG-NORMAL, S: LOG-NORMAL

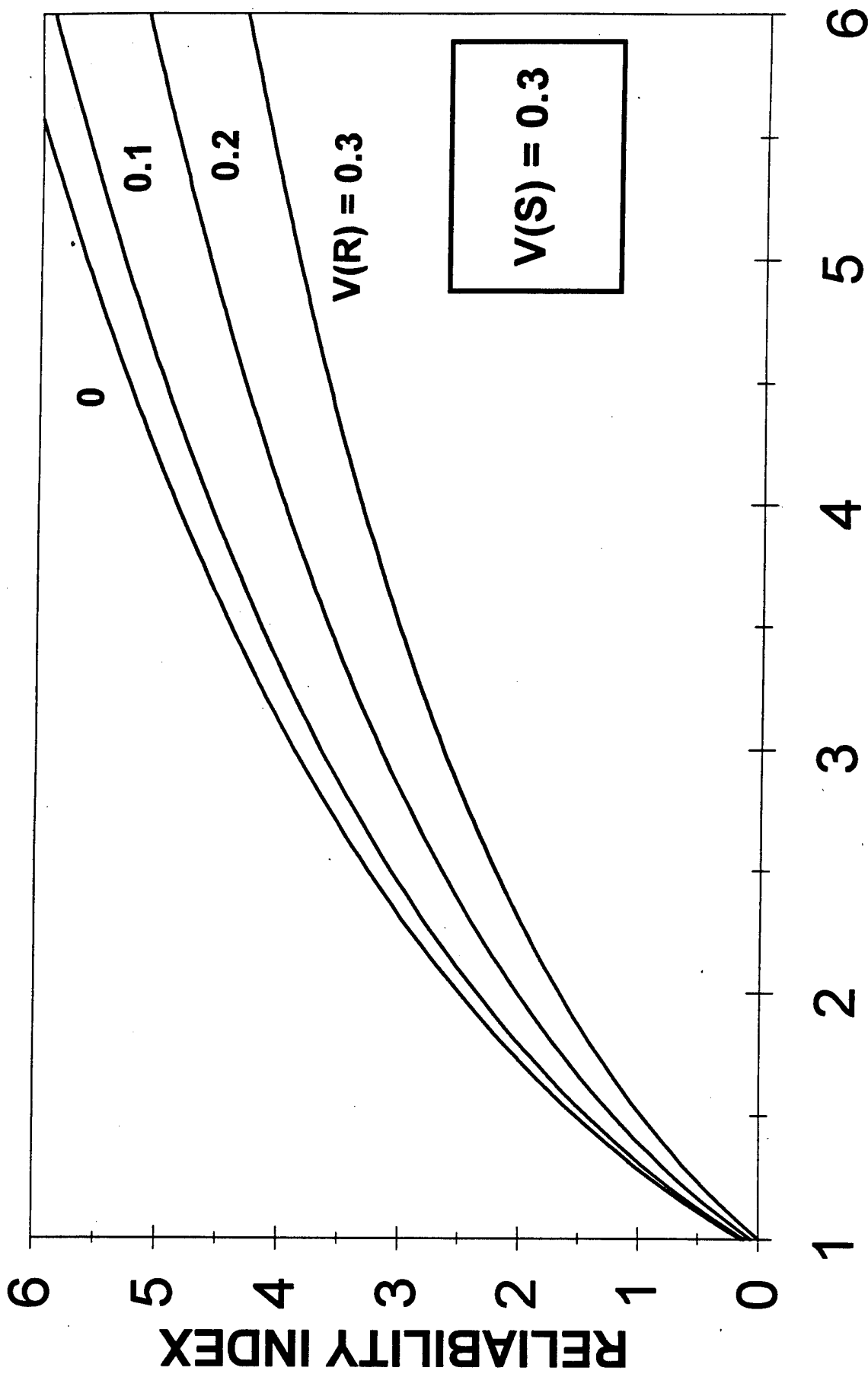

CENTRAL SAFETY FACTOR

R: LOG-NORMAL, S: LOG-NORMAL

$V(S) = 0.3$

$V(R) = 0.3$

0

0.1

0.2

1

2

3

4

5

6

6

5

4

3

2

1

0

RELIABILITY INDEX

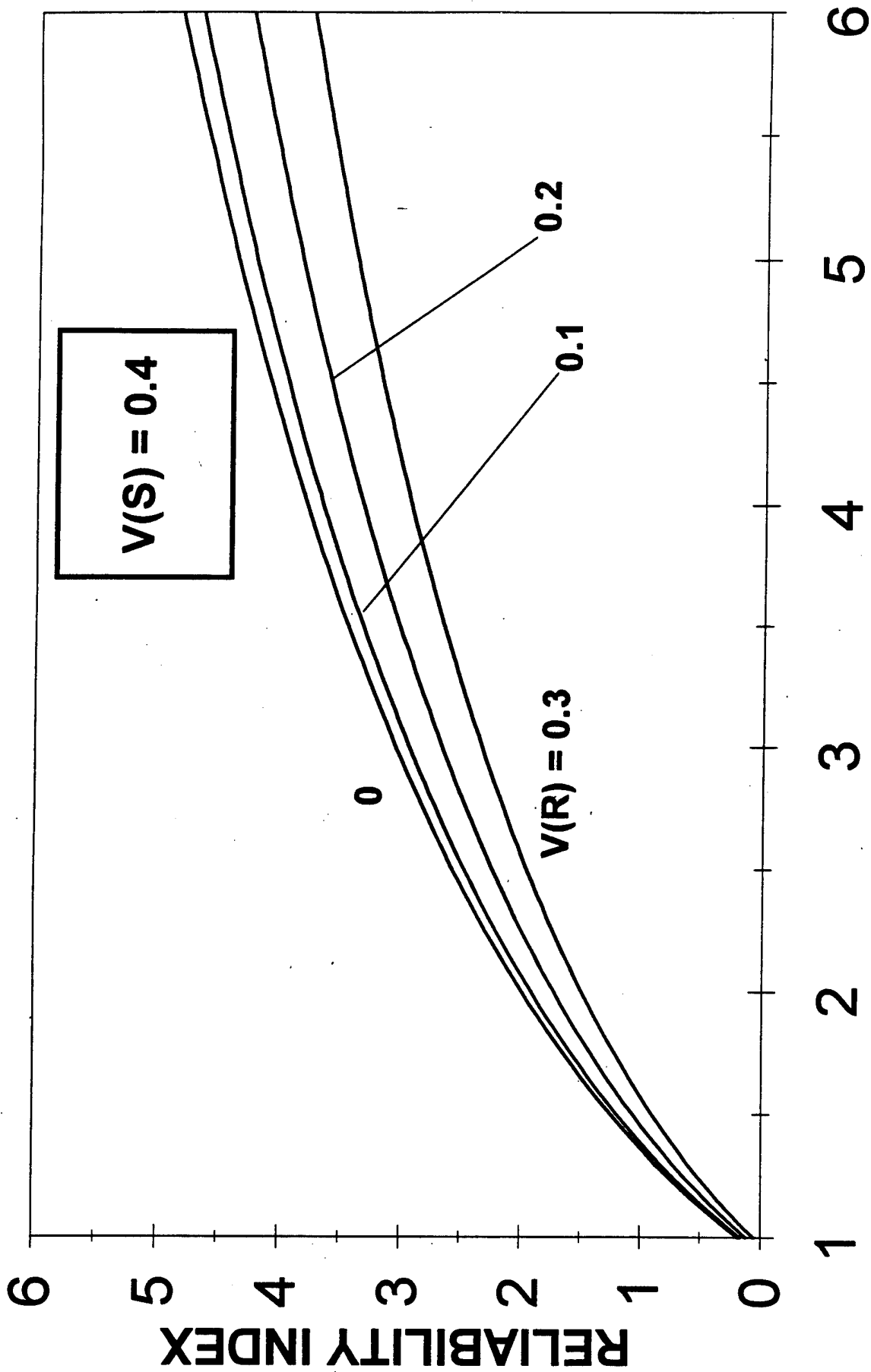

R: LOG-NORMAL, S: LOG-NORMAL

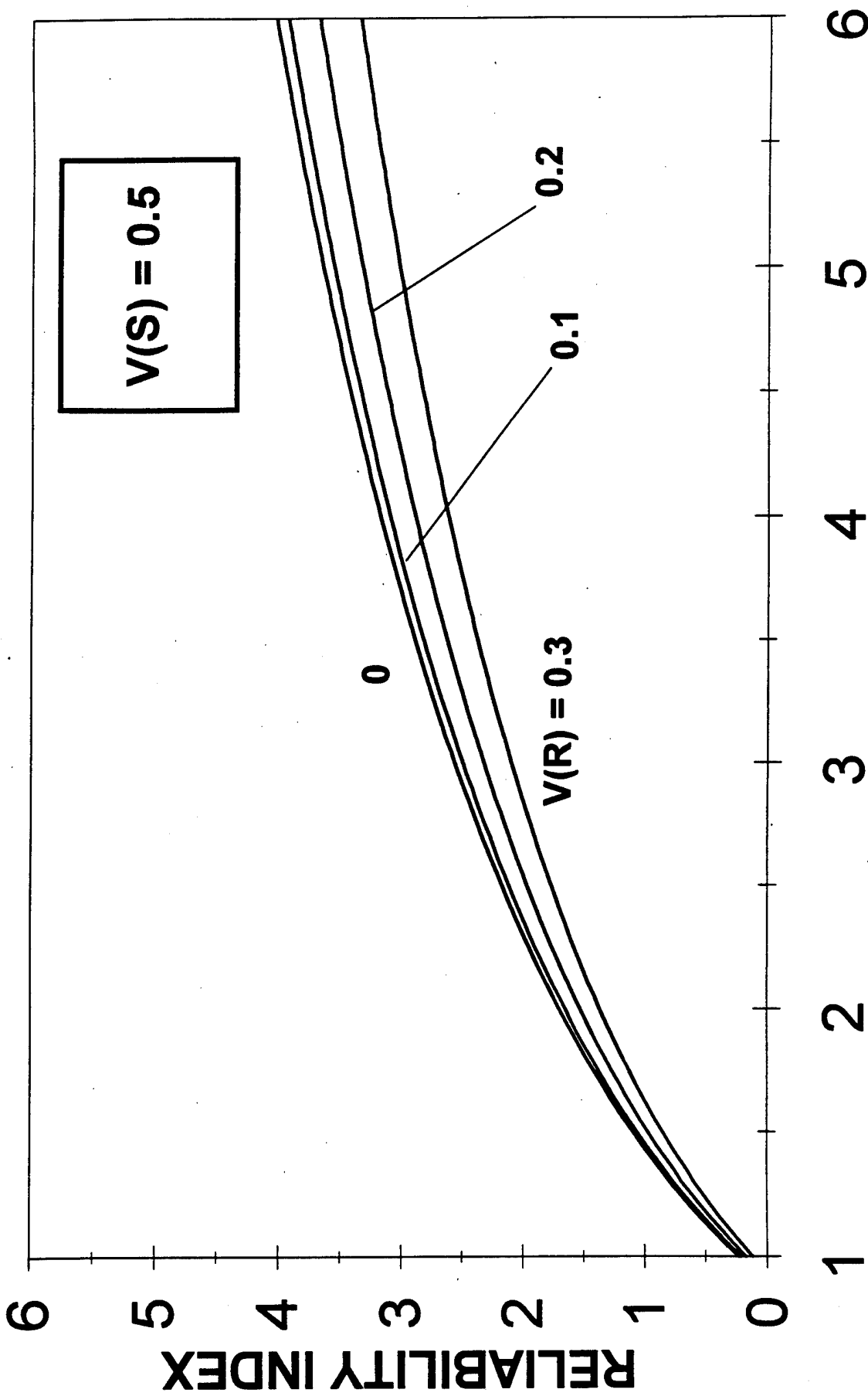

R: LOG-NORMAL, S: LOG-NORMAL

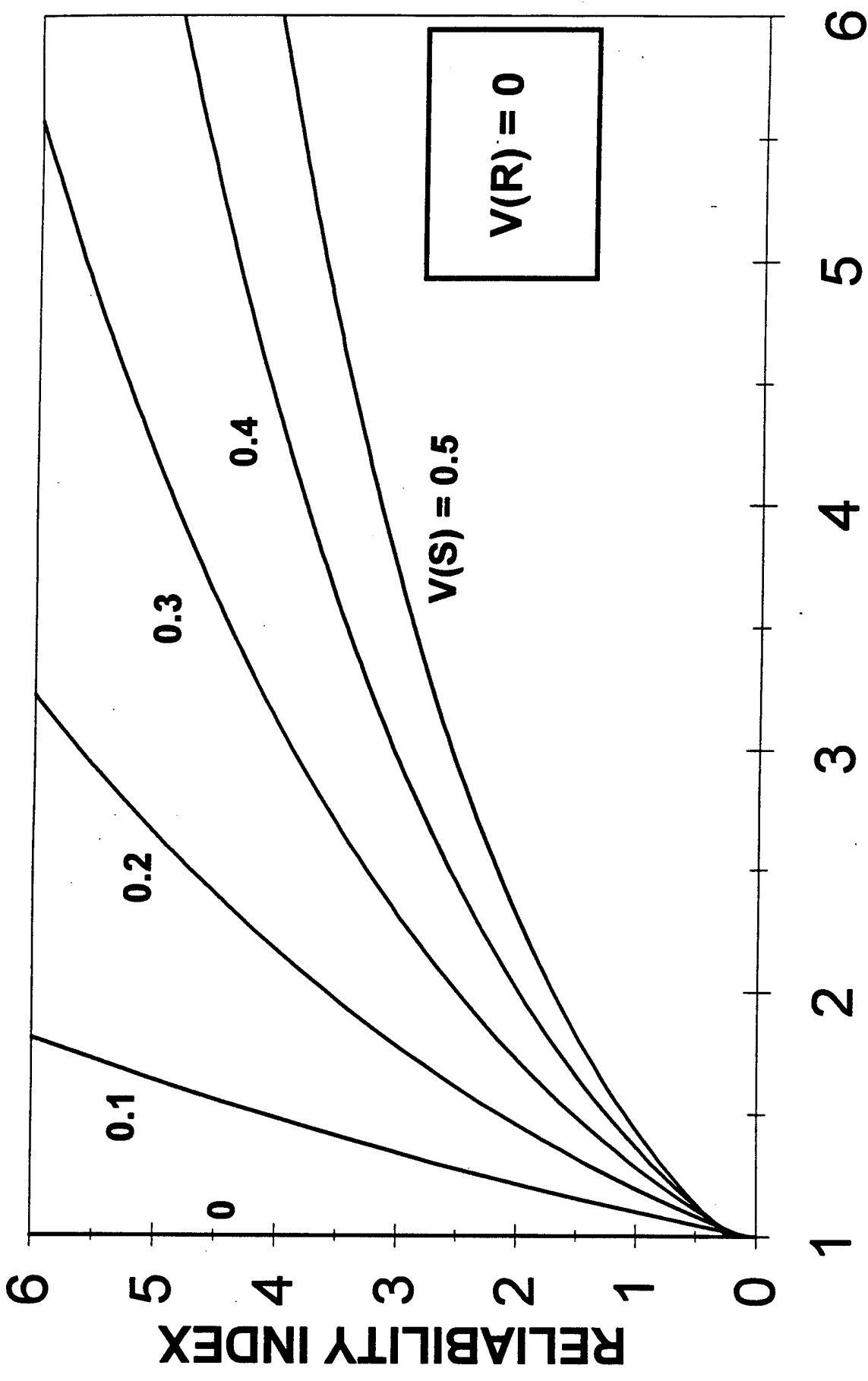

R: LOG-NORMAL, S: LOG-NORMAL

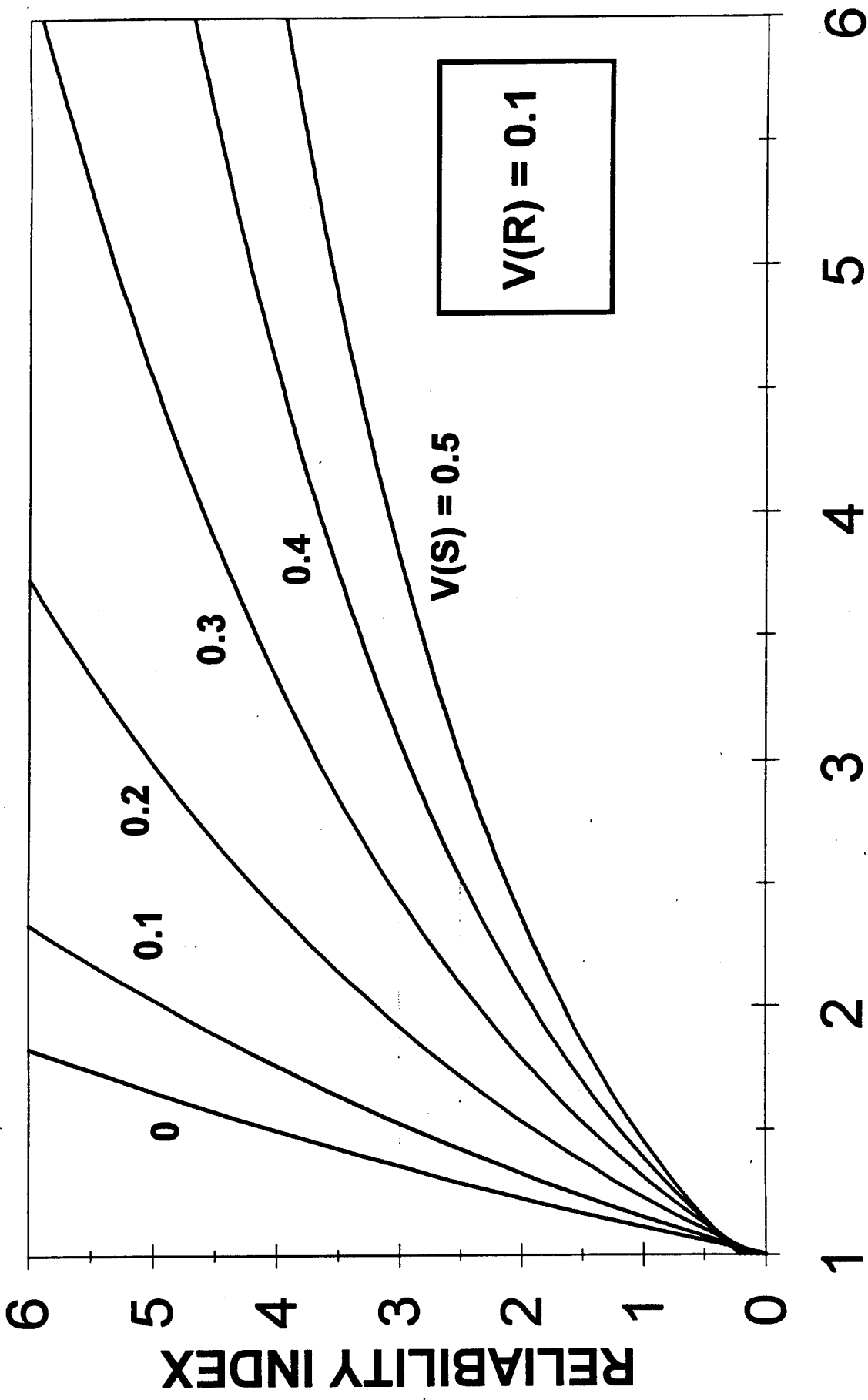

R: LOG-NORMAL, S: LOG-NORMAL

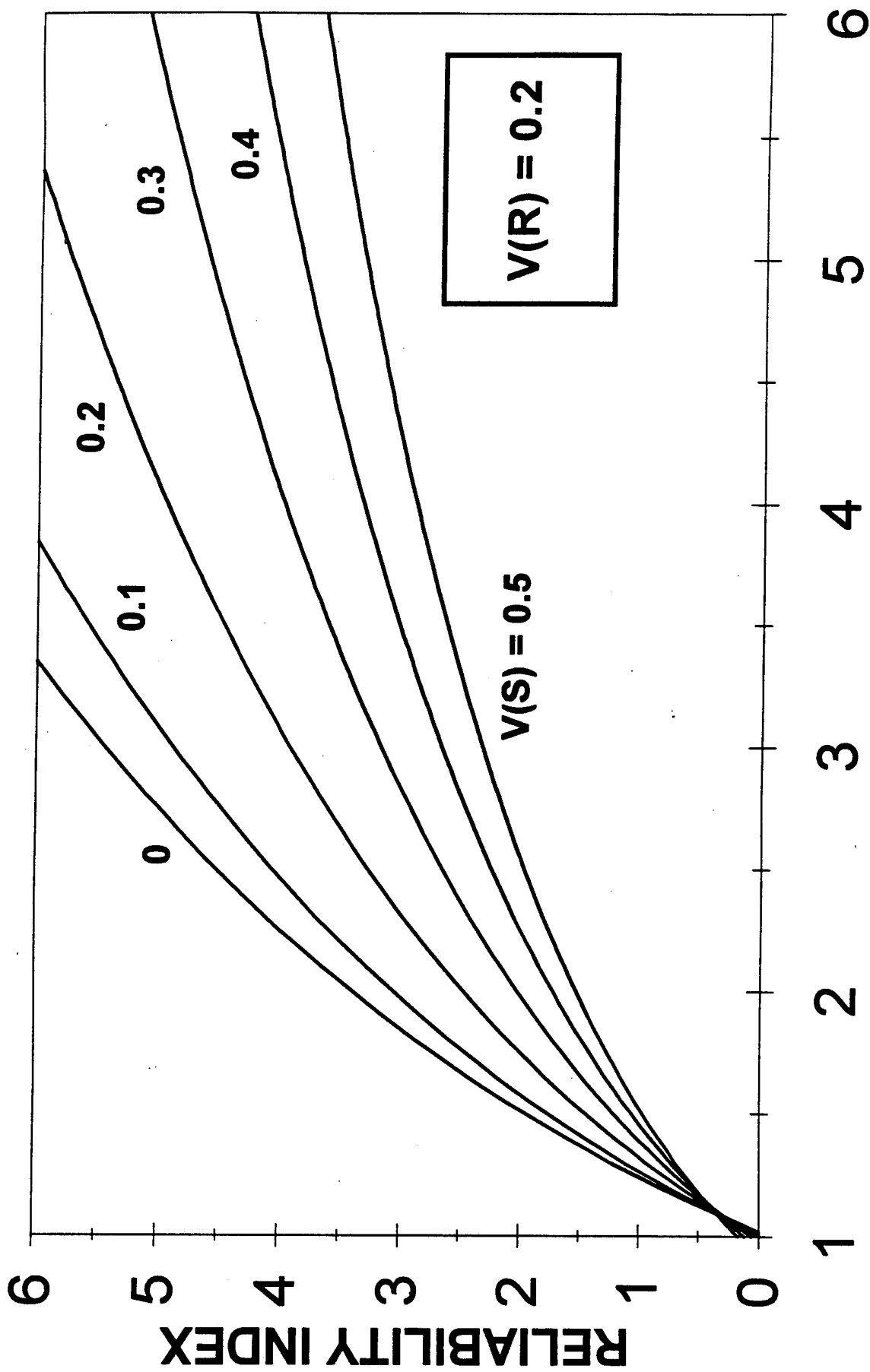

R: LOG-NORMAL, S: LOG-NORMAL

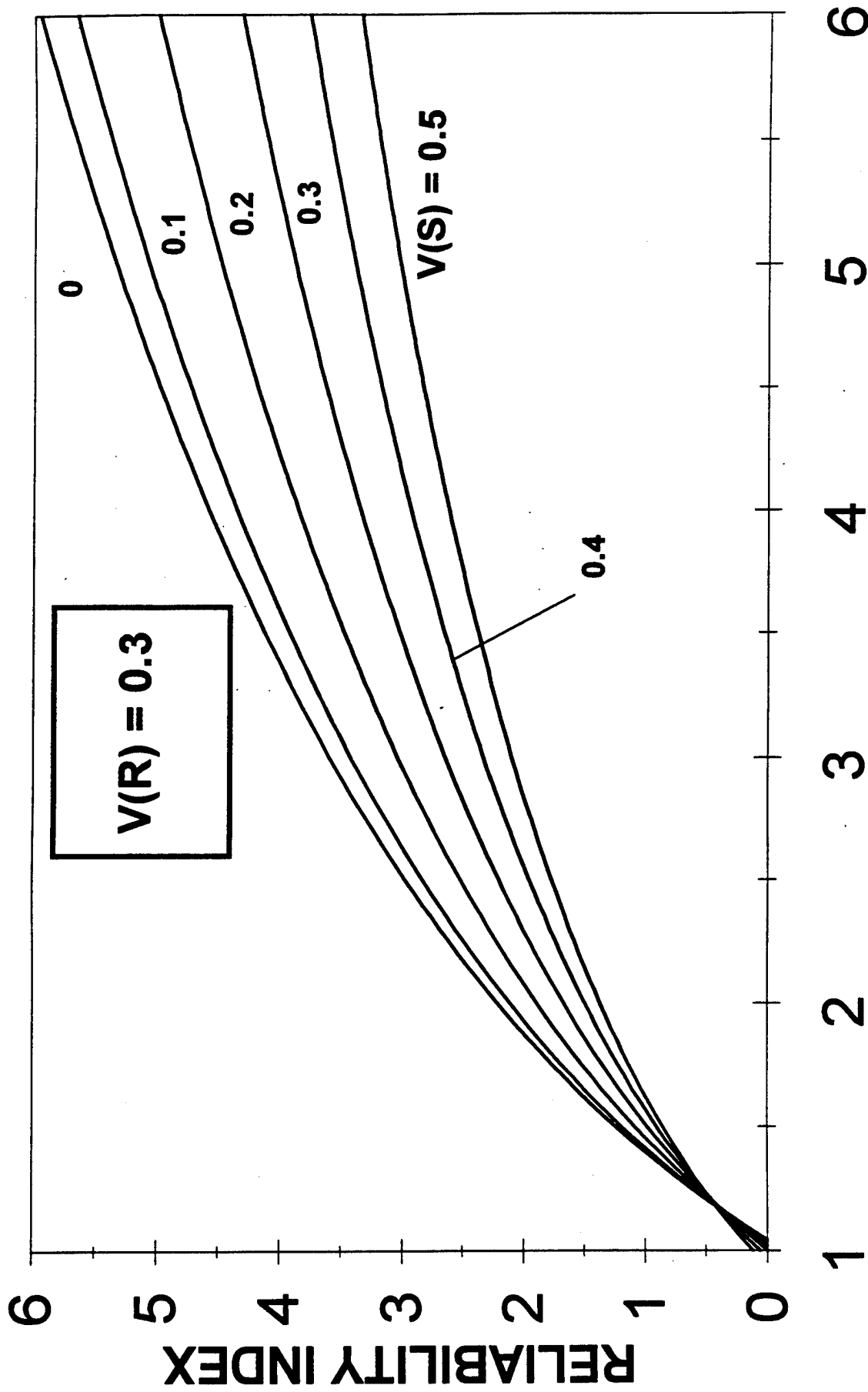

CENTRAL SAFETY FACTOR

R: LOG-NORMAL, S: LOG-NORMAL

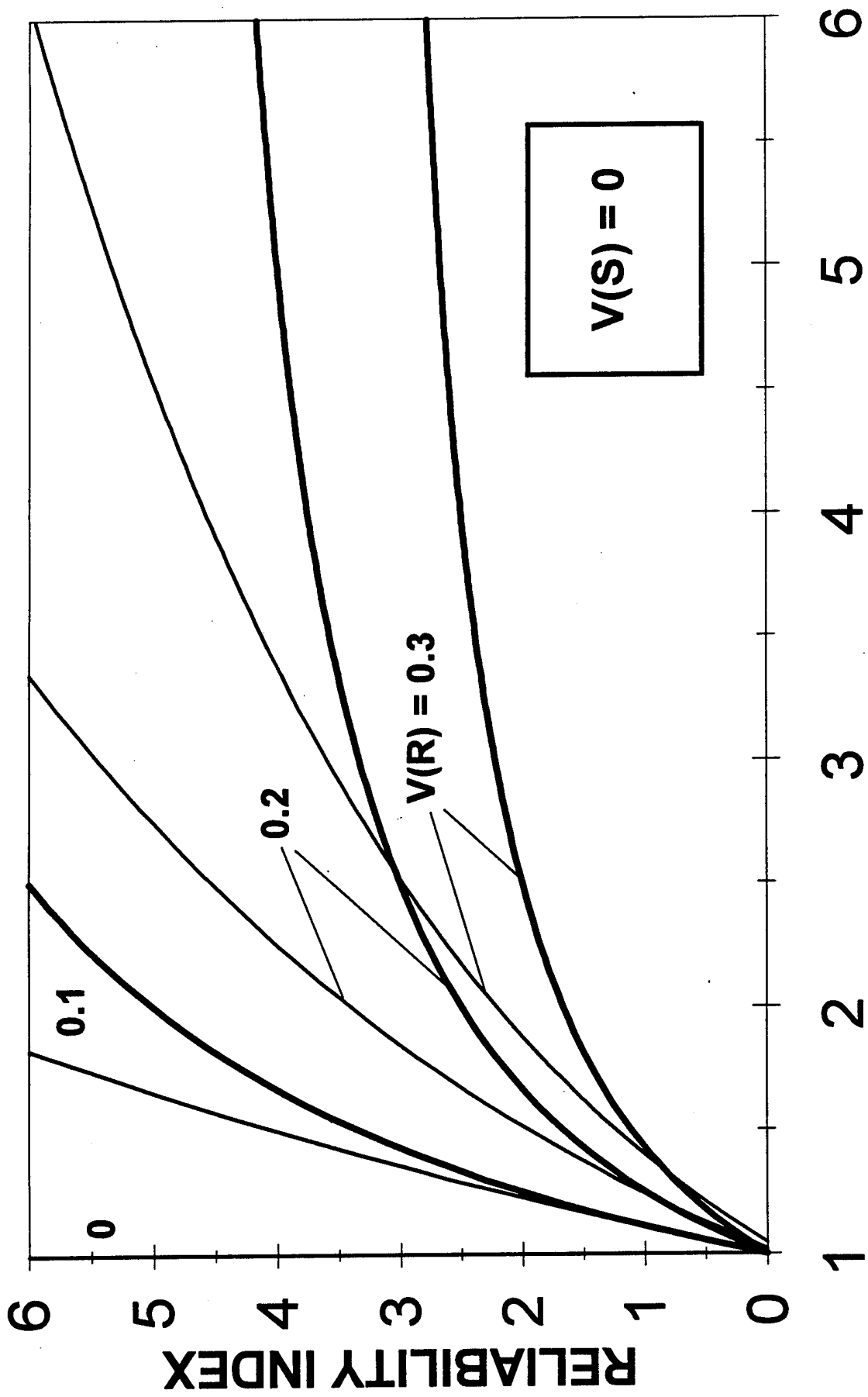

— NORMAL, — LOG-NORMAL

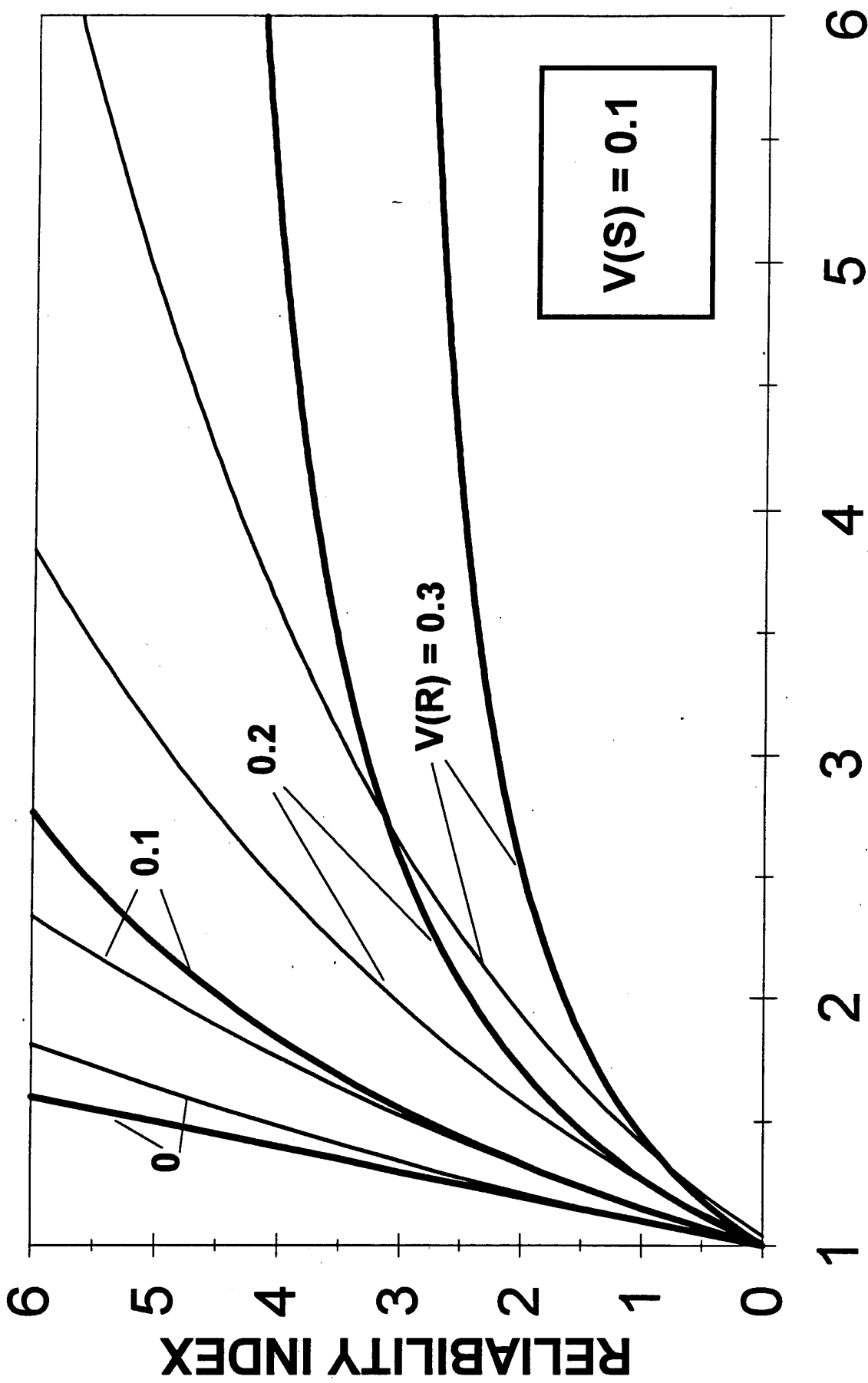

— NORMAL, — LOG-NORMAL

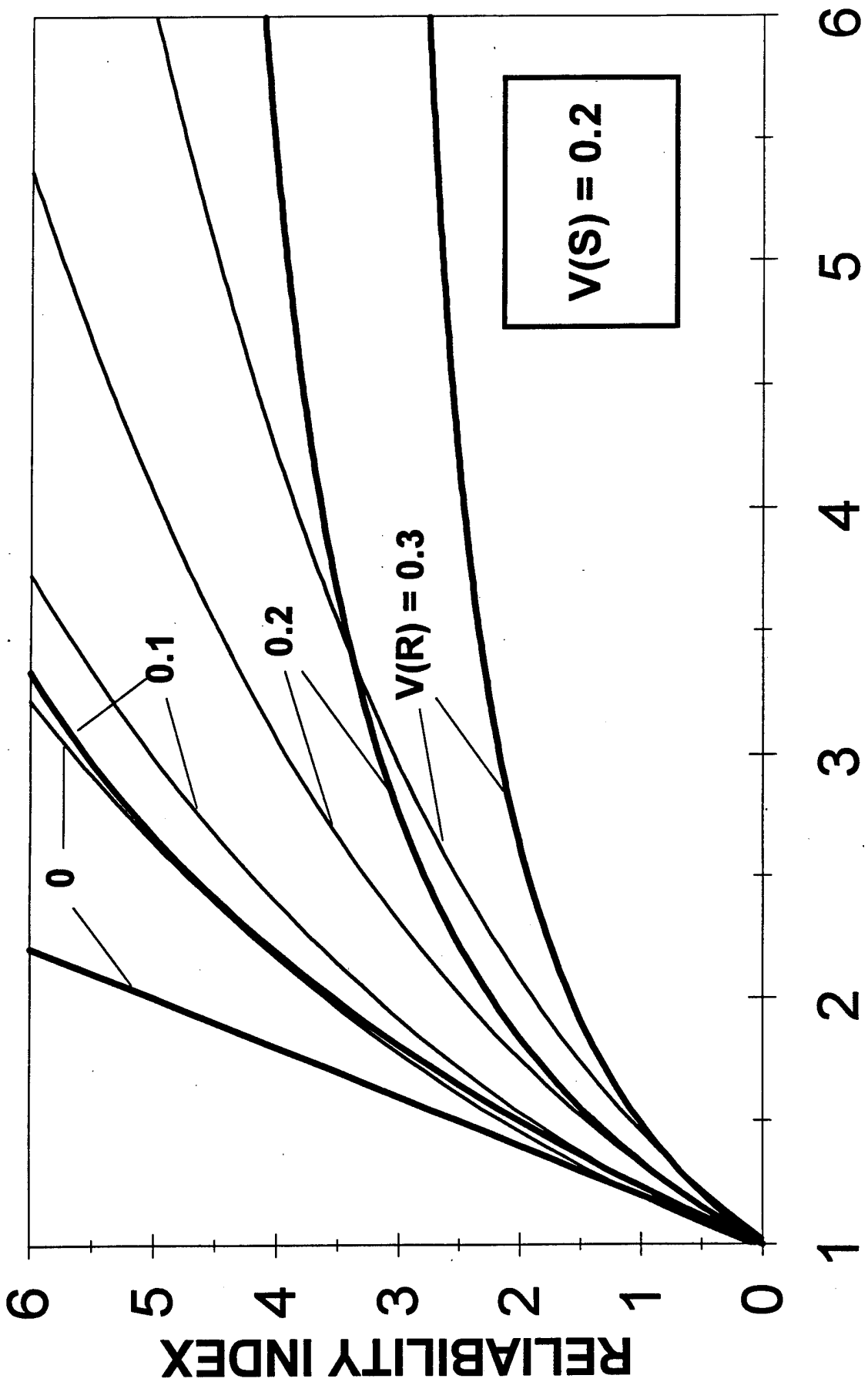

— NORMAL; - - LOG-NORMAL

$V(S) = 0.2$

$V(R) = 0.3$

0.2

0.1

0

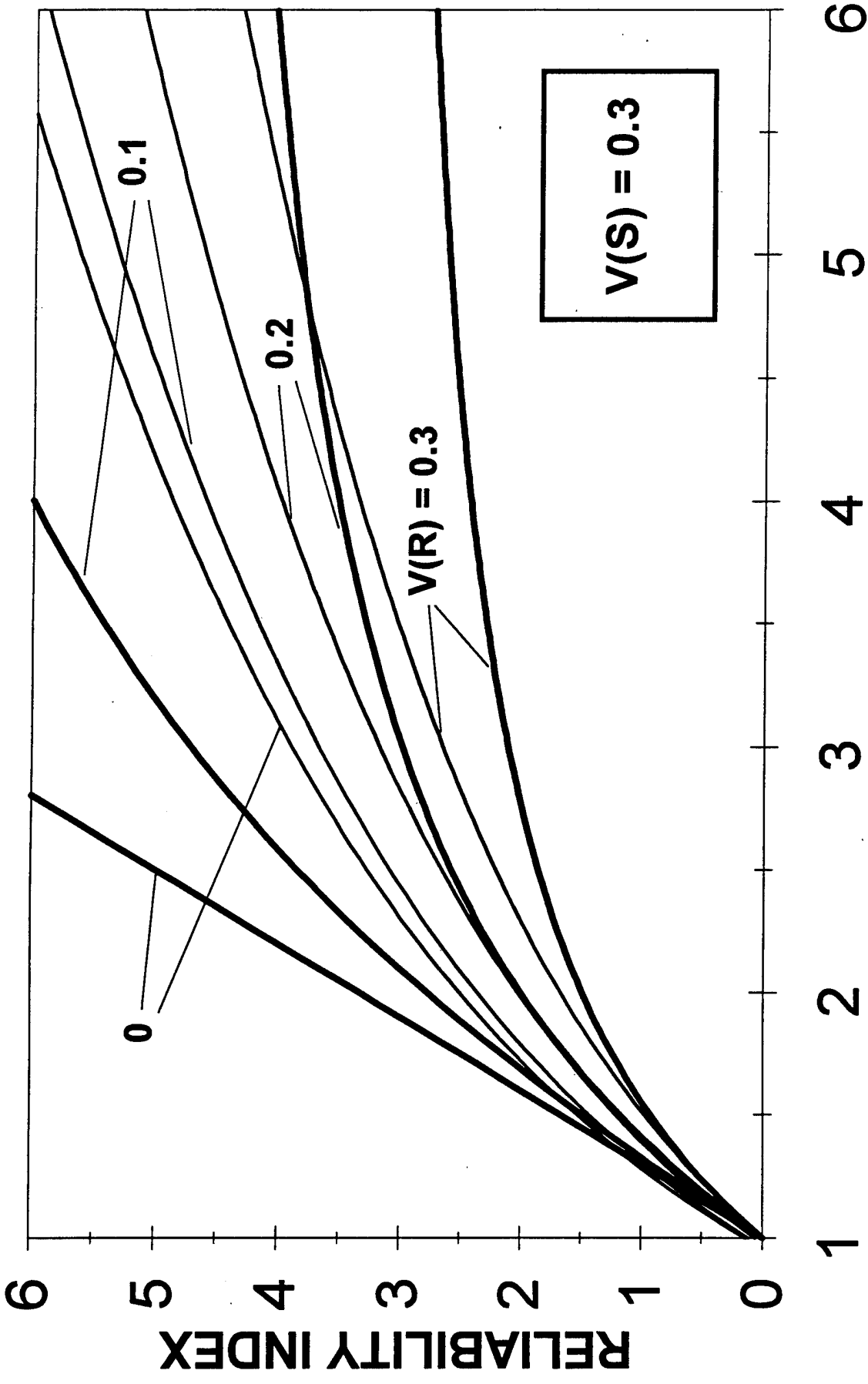

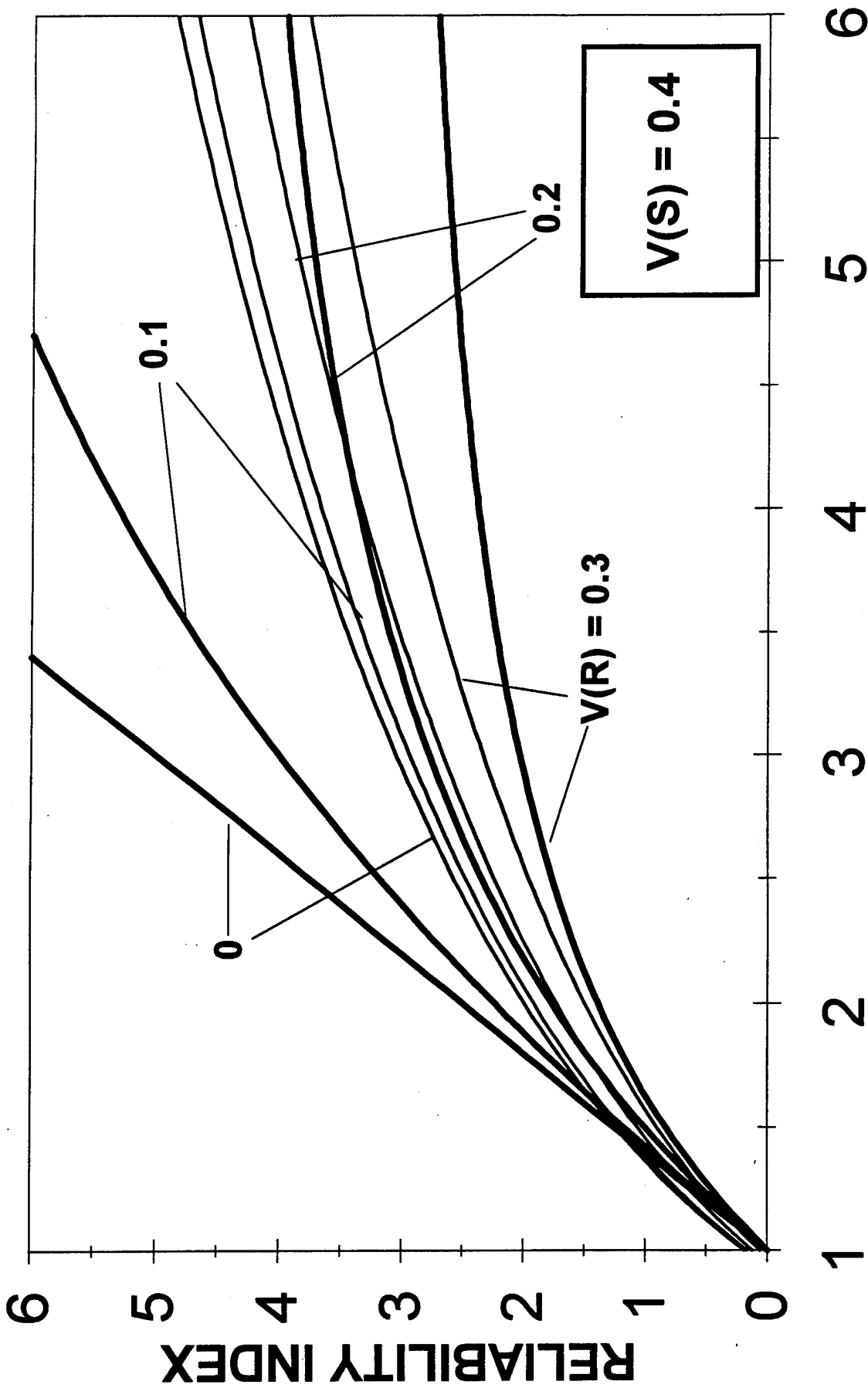

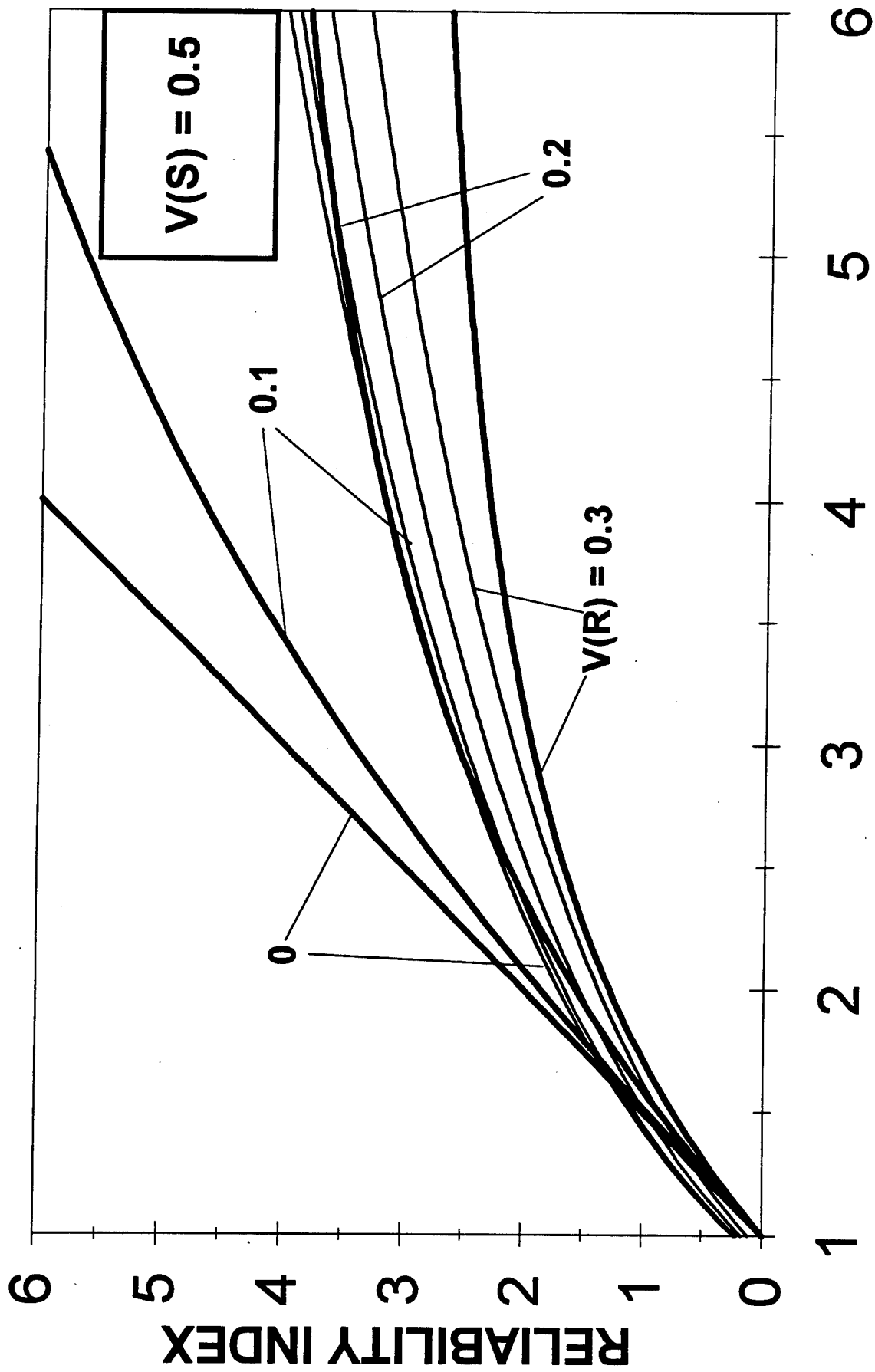

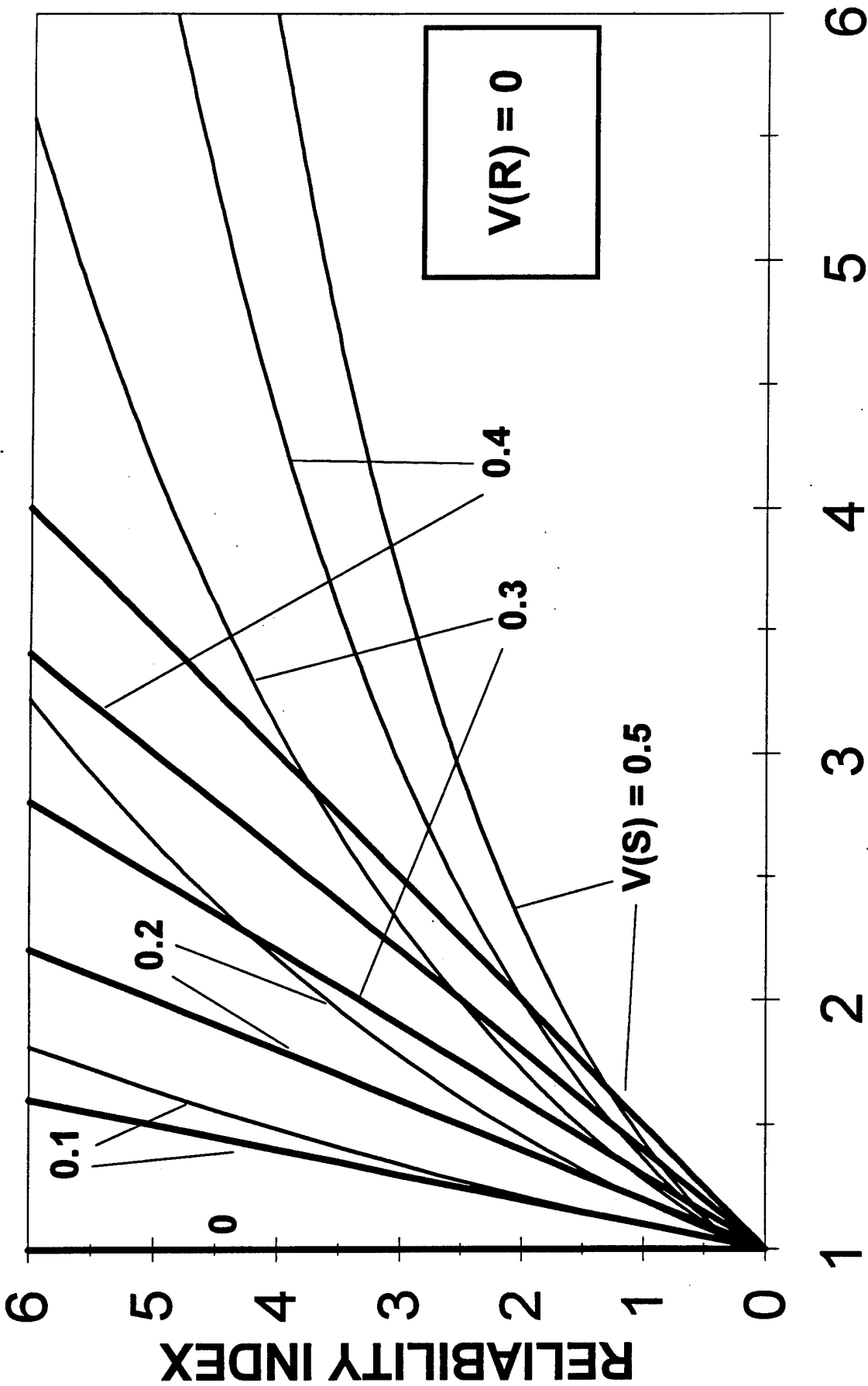

— NORMAL, - - - LOG-NORMAL

CENTRAL SAFETY FACTOR

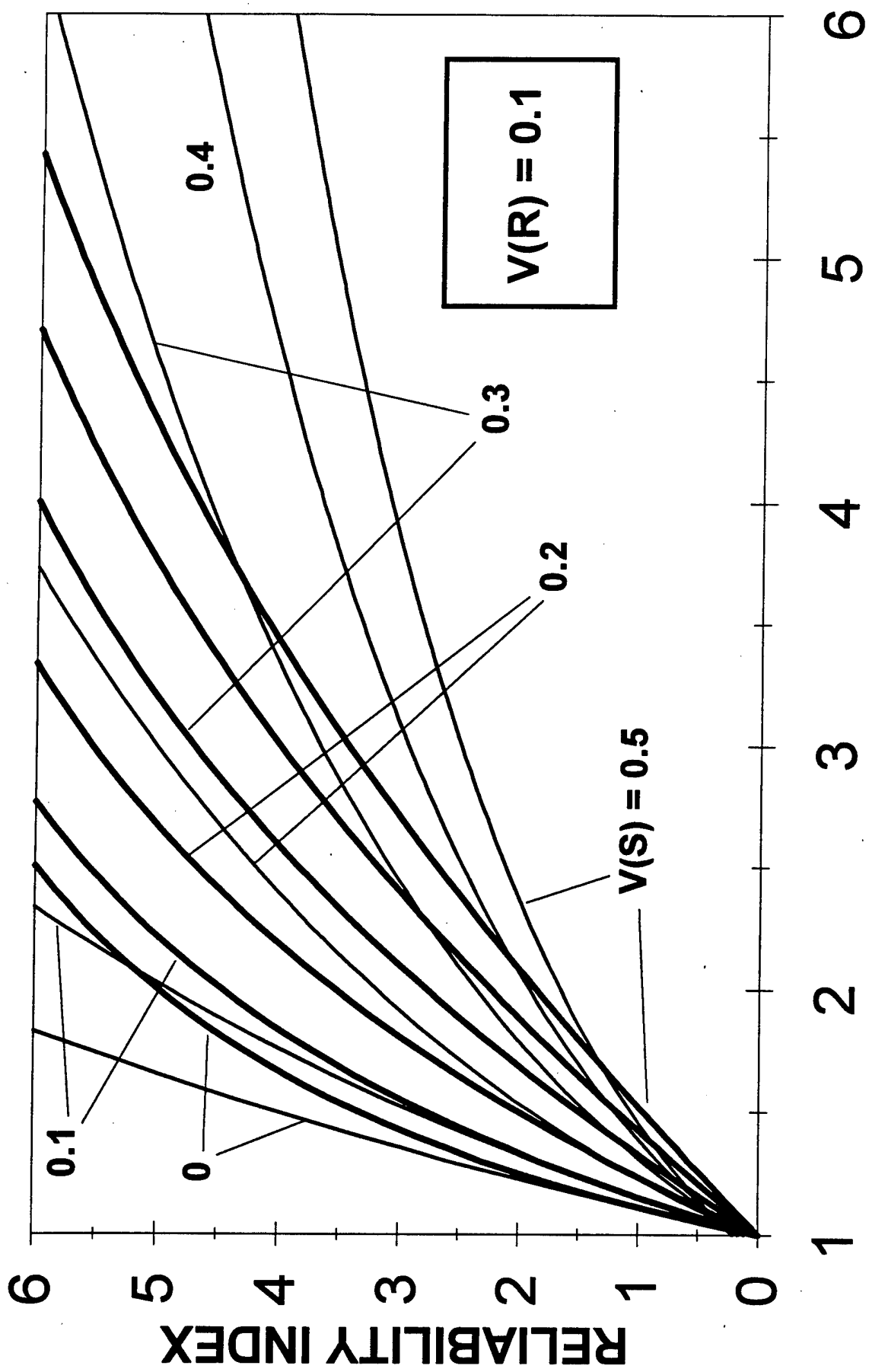

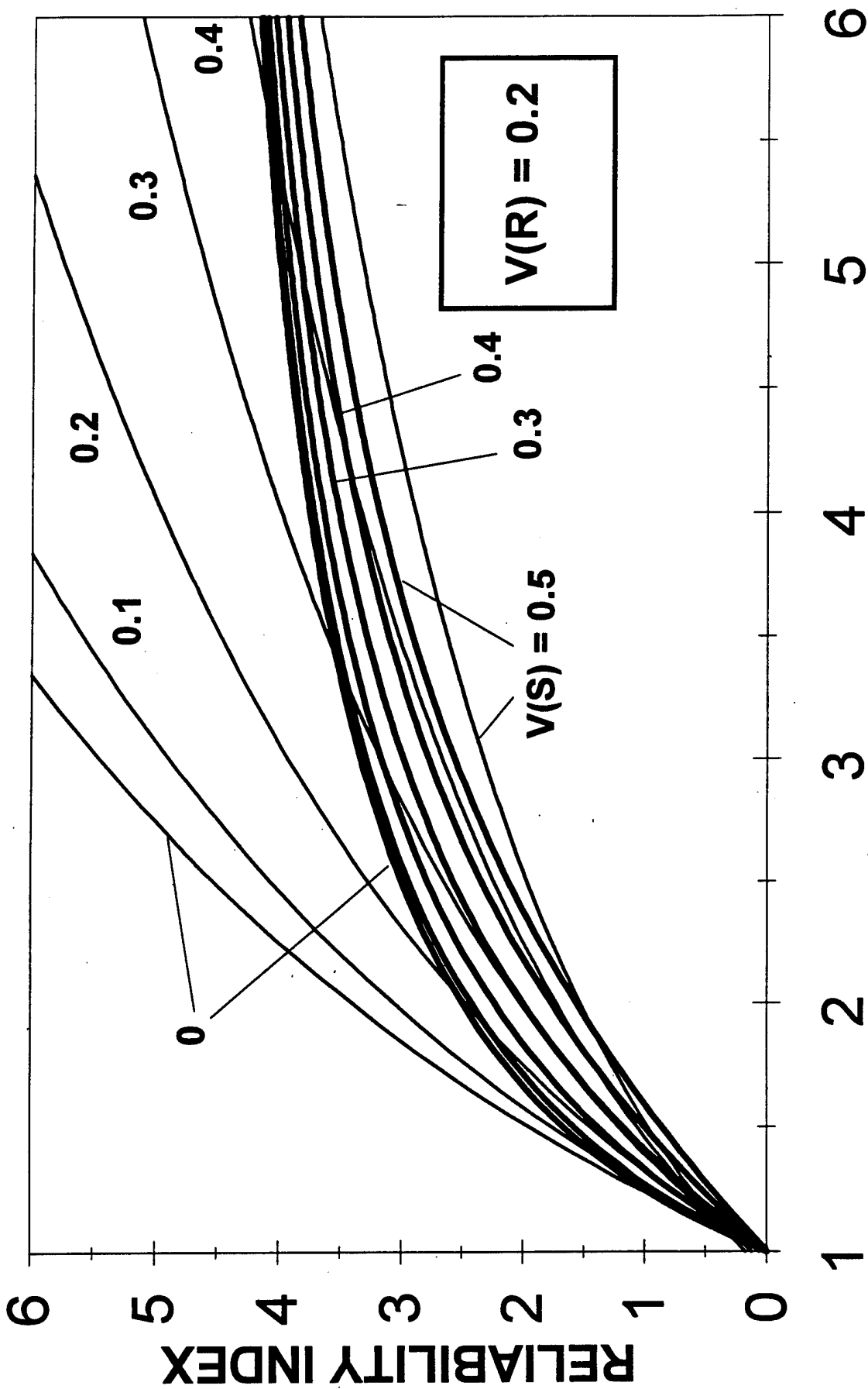

— NORMAL, - - LOG-NORMAL

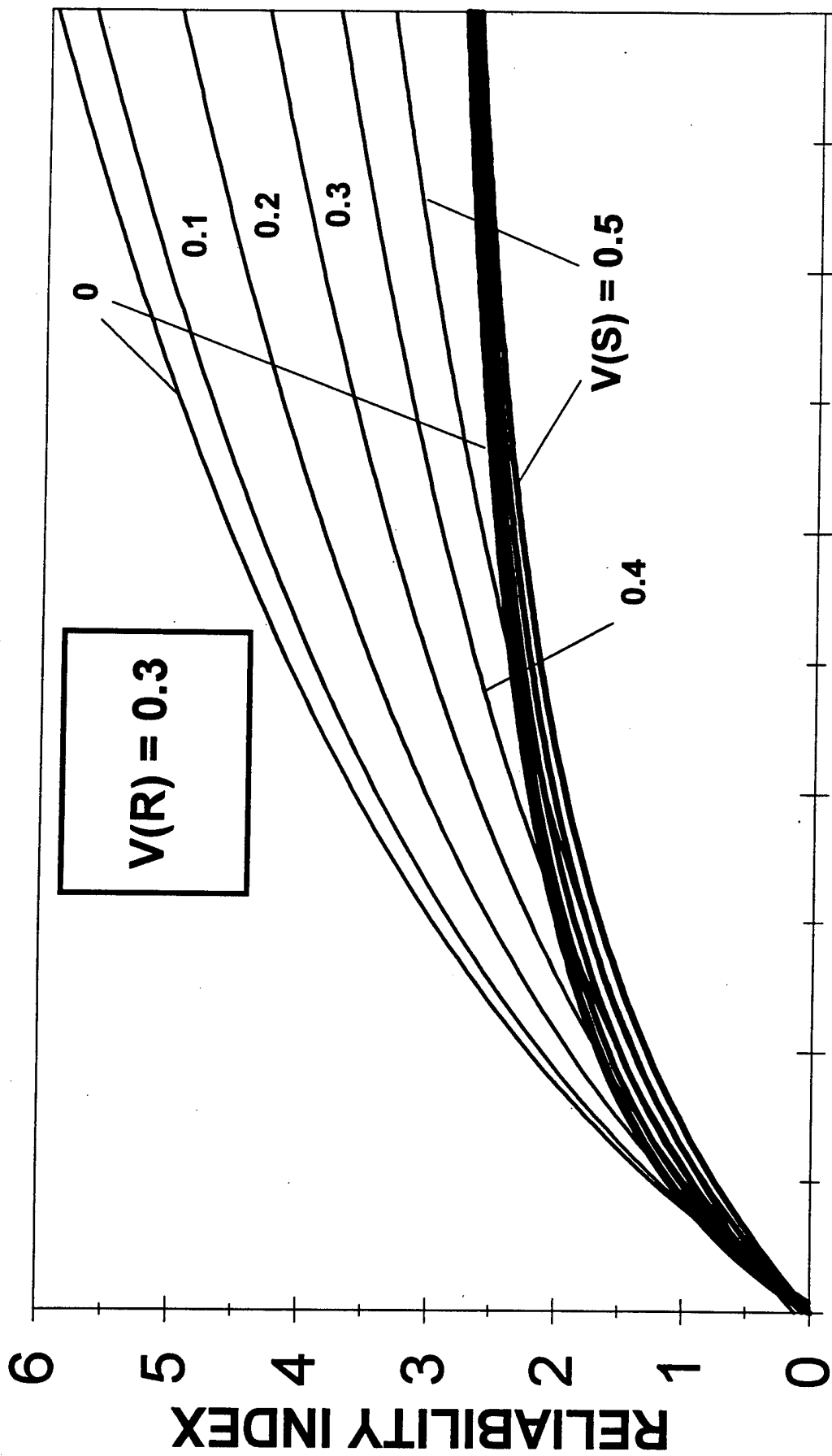

CENTRAL SAFETY FACTOR

— NORMAL, — LOG-NORMAL

$V(R) = 0.3$

$V(S) = 0.5$

0

0.1

0.2

0.3

0.4

6

5

4

3

2

1

Appendix A A3

Reliability Interaction Charts *Design for Safety Factor*

	Θ_0 vs V(S)	Θ_0 vs V(R)
Function	Θ_0	Θ_0
<i>Selected Variable</i>	β	β
<i>Discrete Variable</i>	V(R)	V(S)
<i>Continuous Variable</i>	V(S)	V(R)

Cases

Normal Variates A3.1-1 → A3.1-14
Log-Normal Variates A3.2-1 → A3.2-14
Comparison of Variates. A3.3-1 → A3.3-14

Function	1.1 ≤ Θ_0 ≤ 6.0	all charts
<i>Variables</i> Select each β Display all V(R), V(S)	β: 2, 2.5, 3, 3.5, 4, 4.5, 5 V(R): 0, 0.1, 0.2, 0.3 0 ≤ V(S) ≤ 0.5	both cases Θ_0 vs V(S) type
Select each β Display all V(R), V(S)	β: 2, 2.5, 3, 3.5, 4, 4.5, 5 V(S): 0, 0.1, 0.2, 0.3, 0.4, 0.5 0 ≤ V(R) ≤ 0.3	both cases Θ_0 vs V(R) type

$$\text{Normal: } \theta_0 = \frac{1 + \beta \sqrt{V_R^2 + V_S^2 - \beta^2 V_R^2 V_S^2}}{1 + \beta^2 V_R^2}$$

$$\text{Log-Normal: } \theta_0 = \exp \left[\beta \sqrt{\ln \left[(1 + V_R^2) (1 + V_S^2) \right]} \right] \sqrt{\frac{1 + V_R^2}{1 + V_S^2}}$$

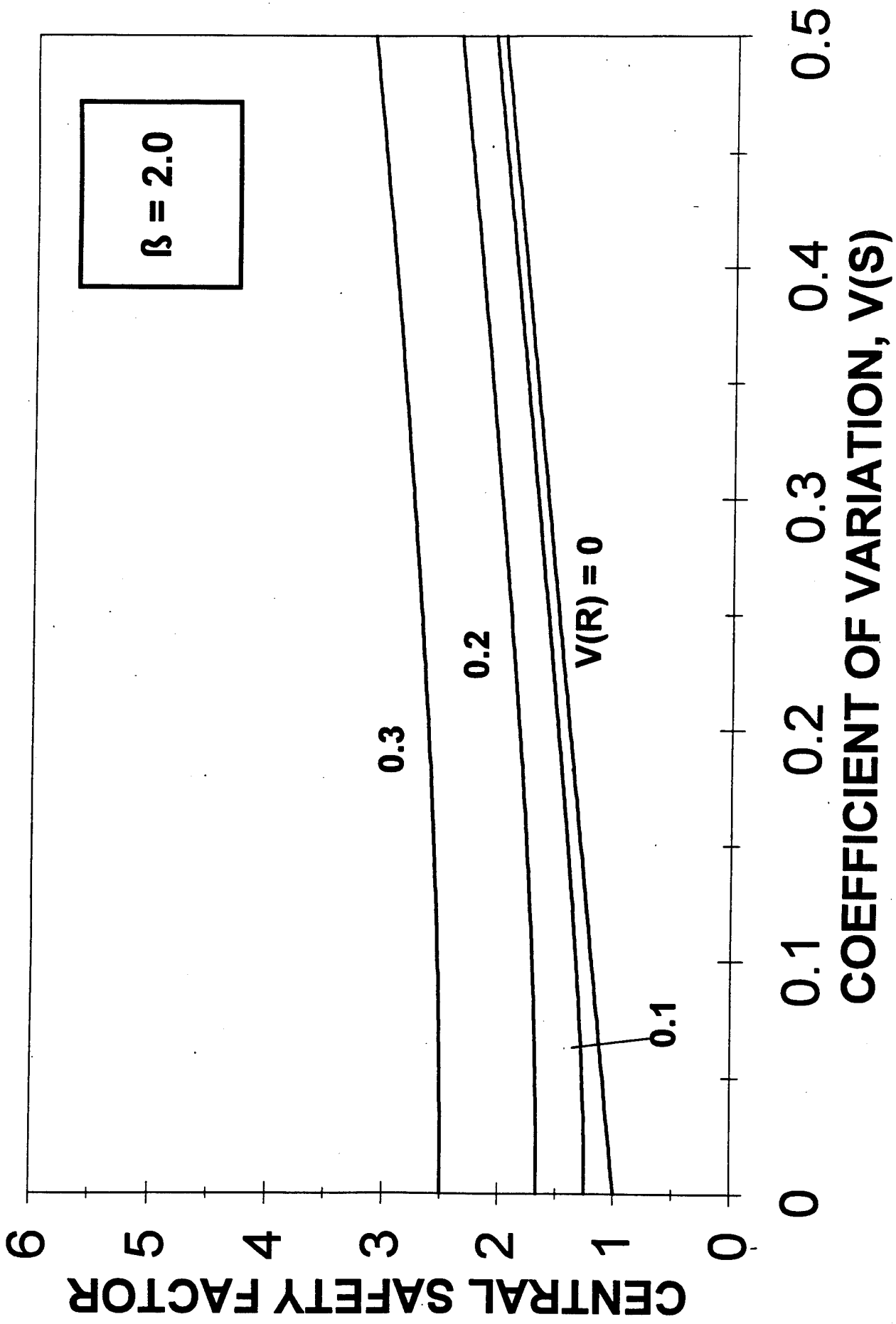

R: NORMAL, S: NORMAL

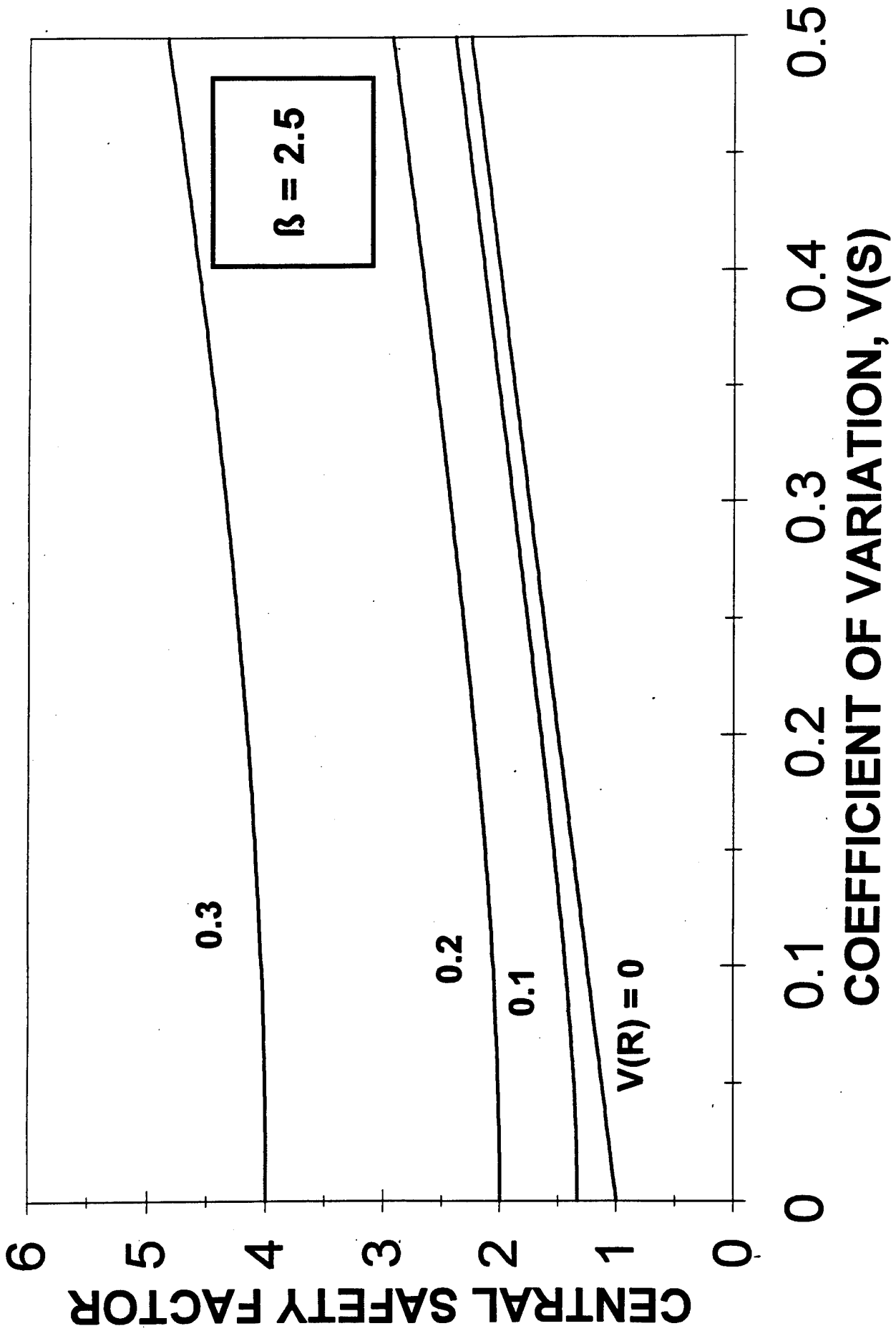

R: NORMAL, S: NORMAL

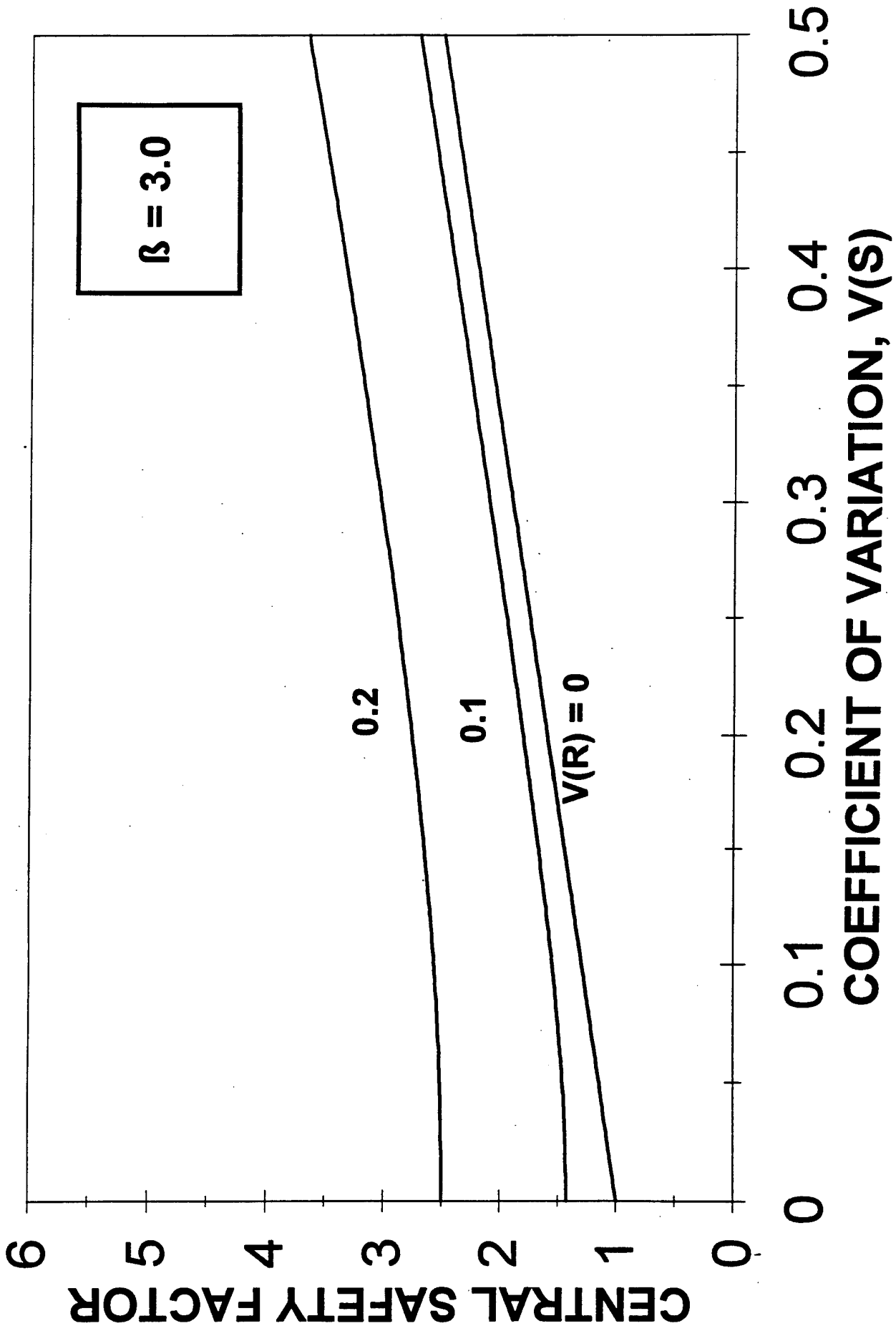

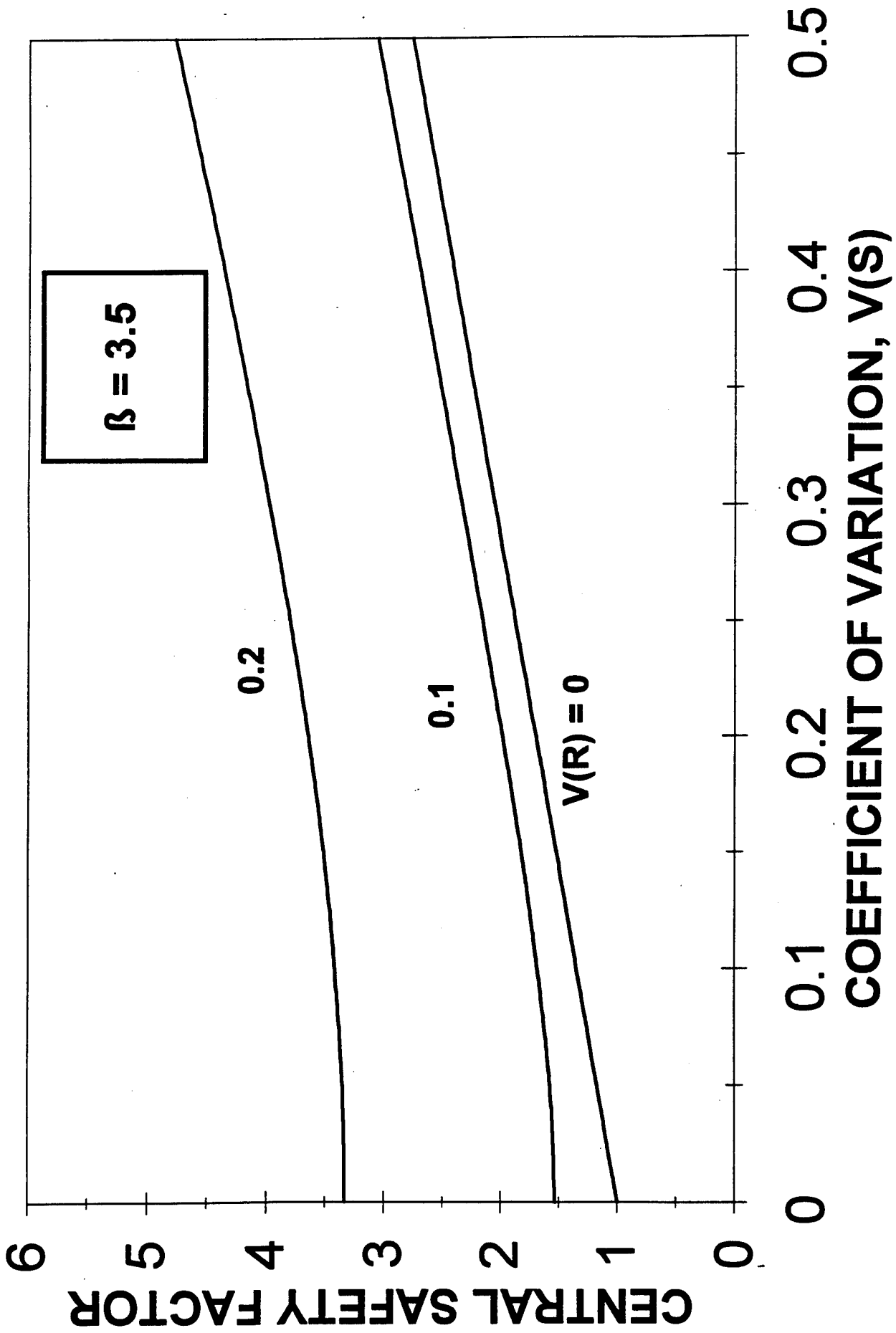

R: NORMAL, S: NORMAL

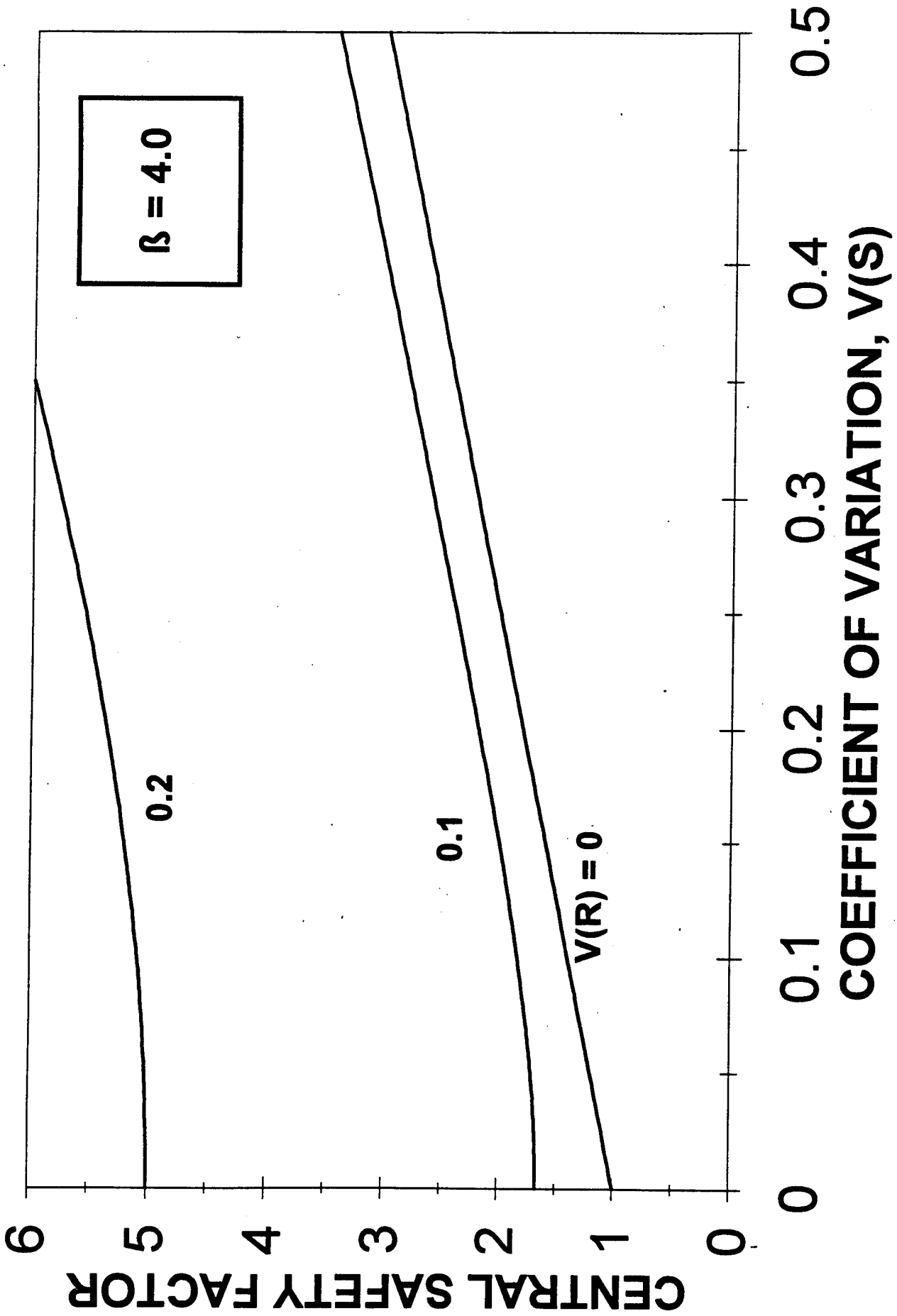

R: NORMAL, S: NORMAL

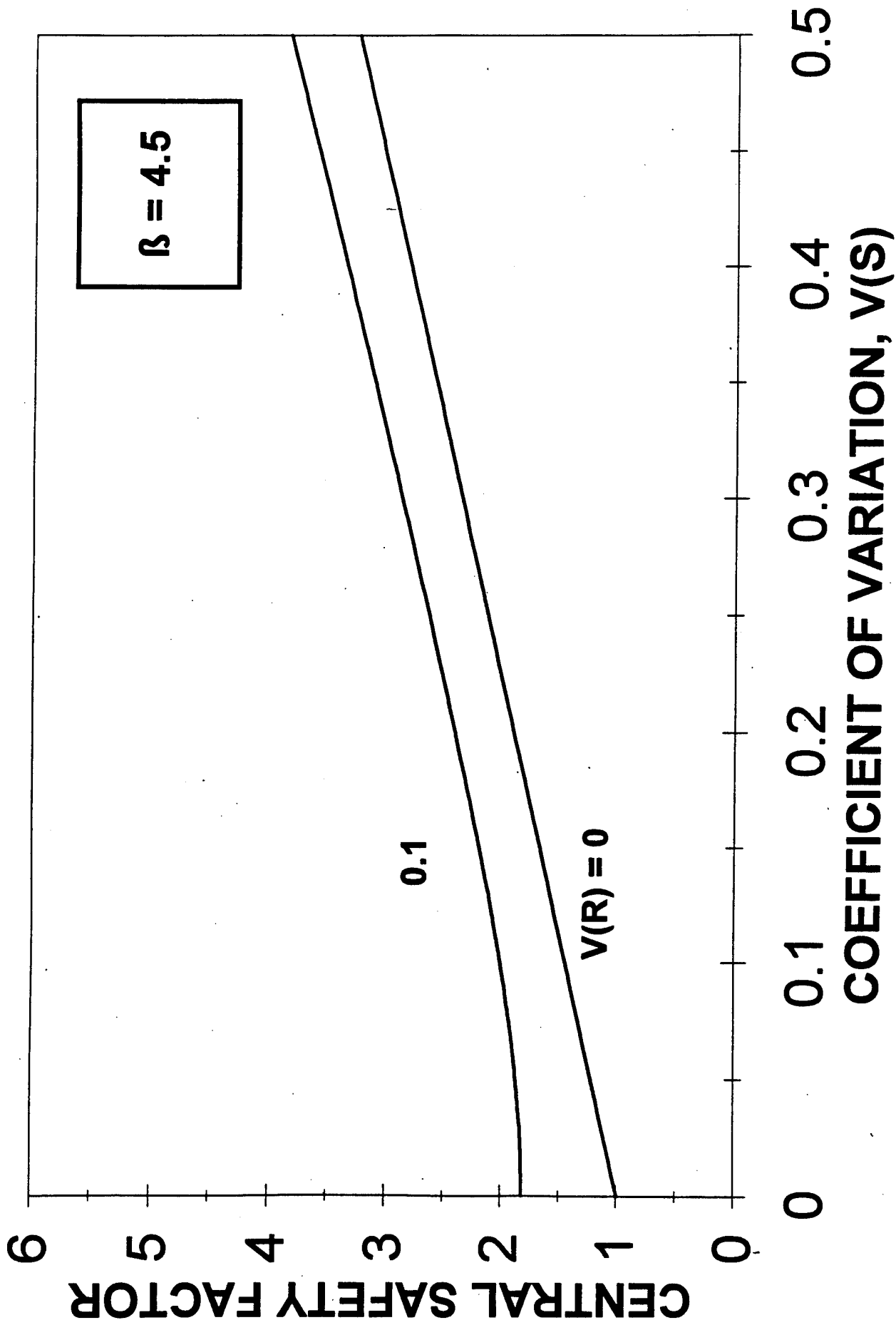

R: NORMAL, S: NORMAL

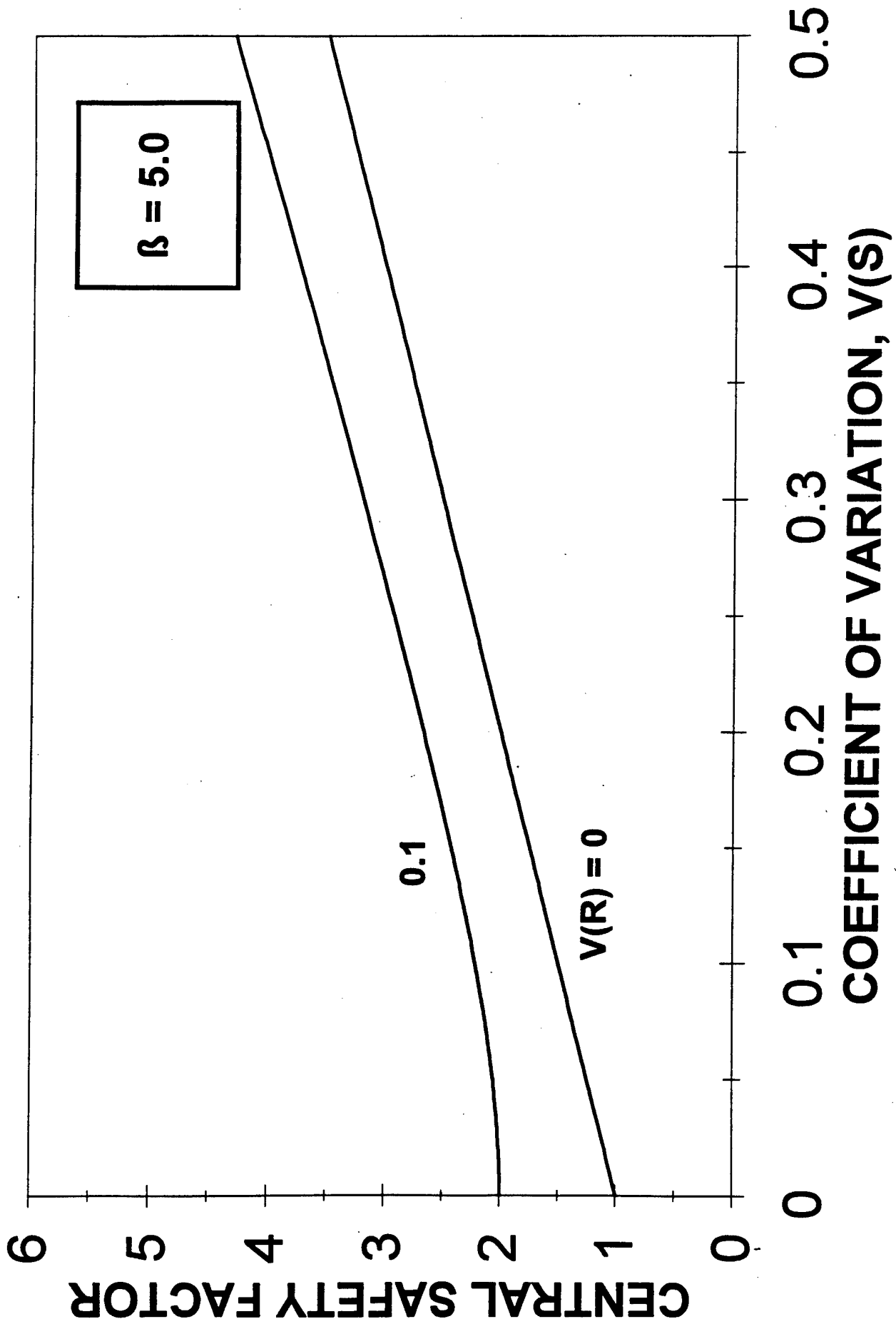

R: NORMAL, S: NORMAL

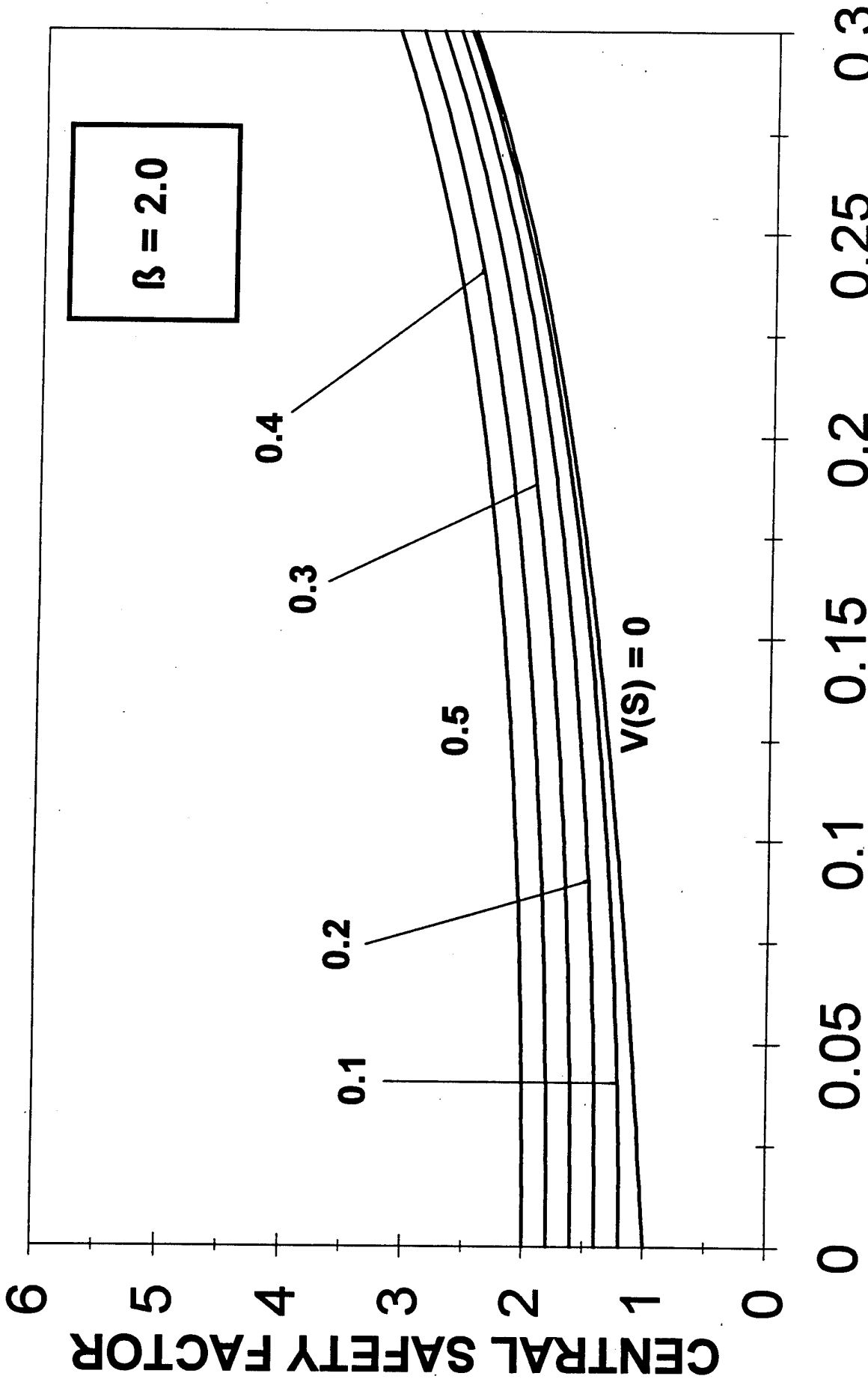

R: NORMAL, S: NORMAL

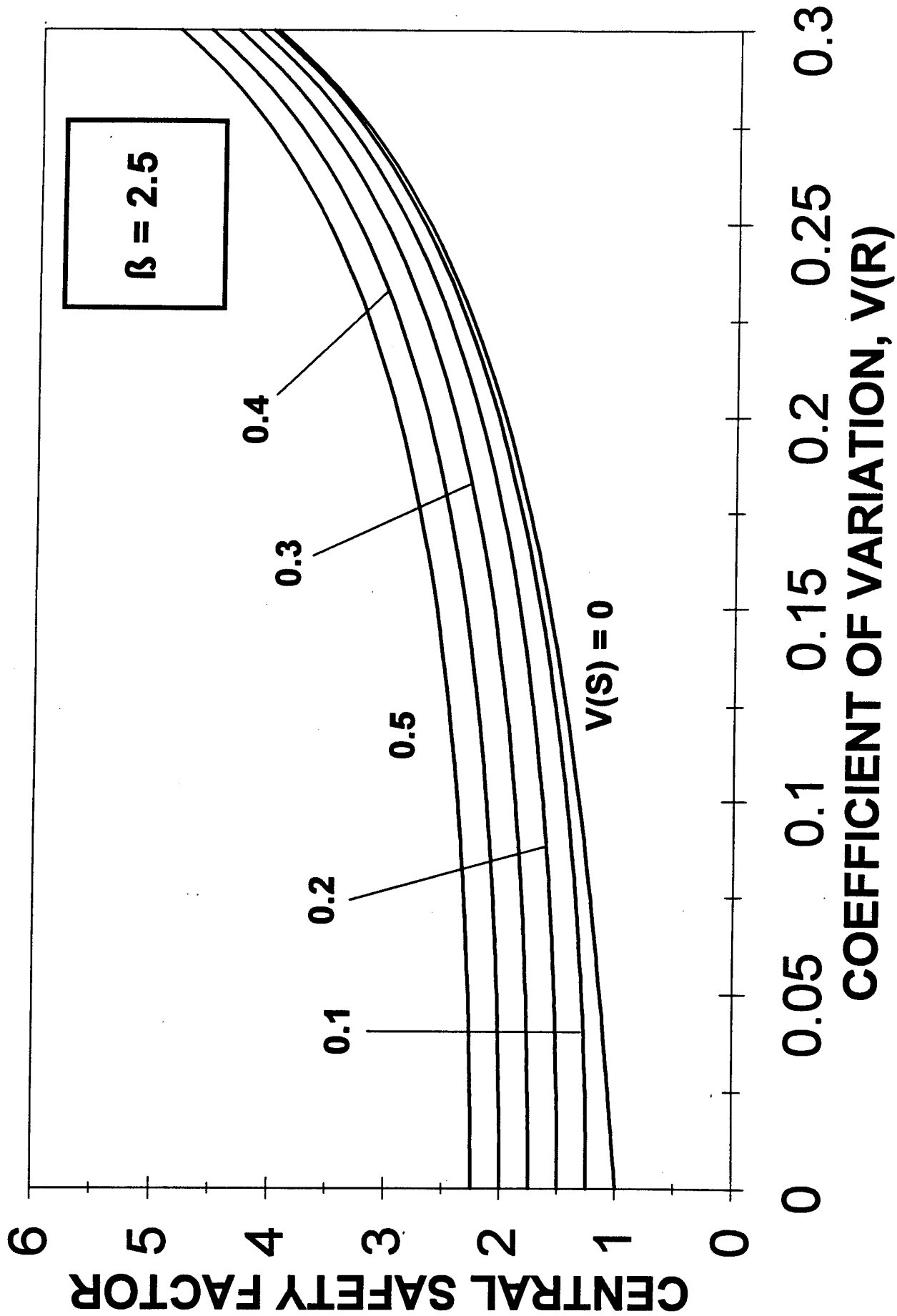

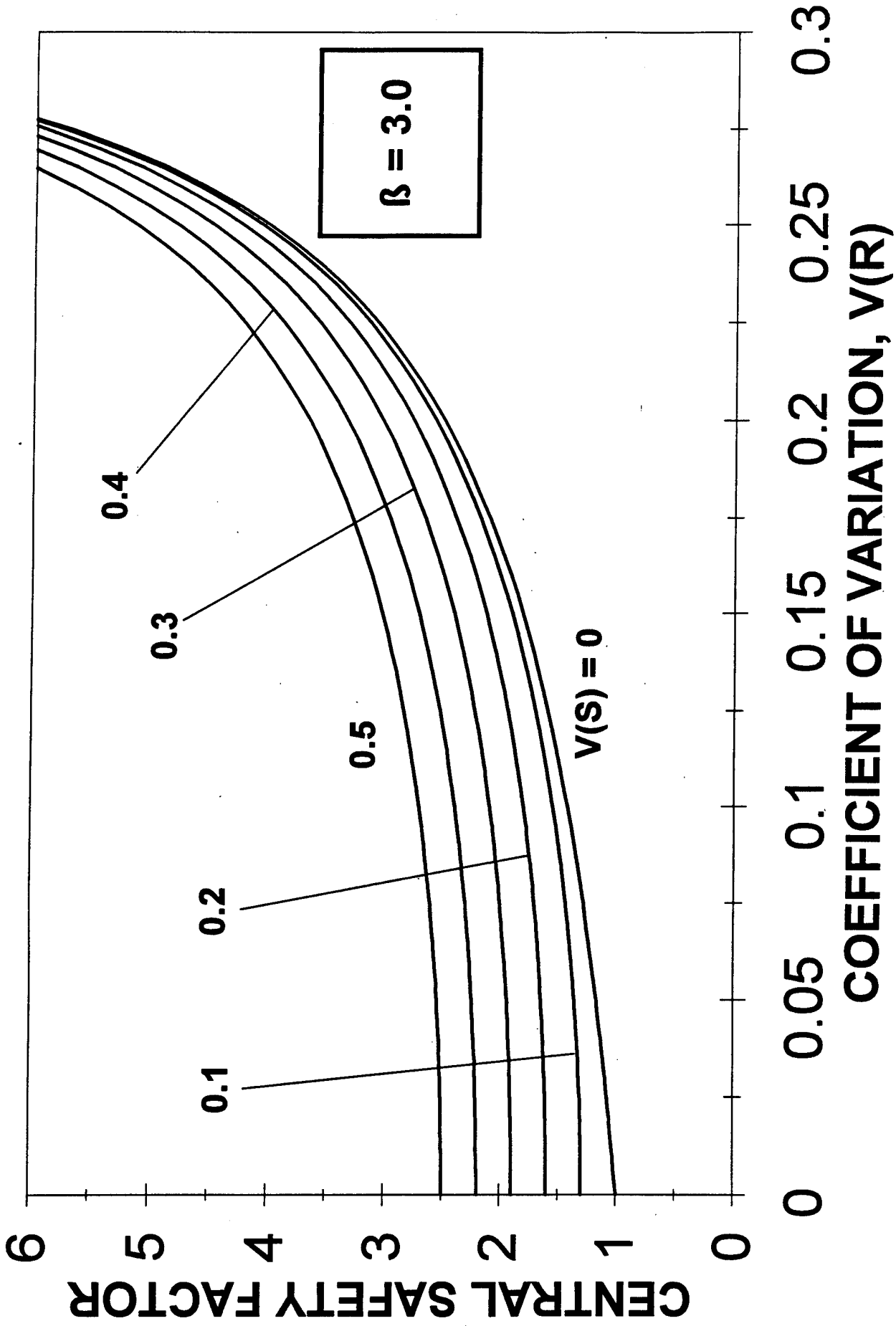

R: NORMAL, S: NORMAL

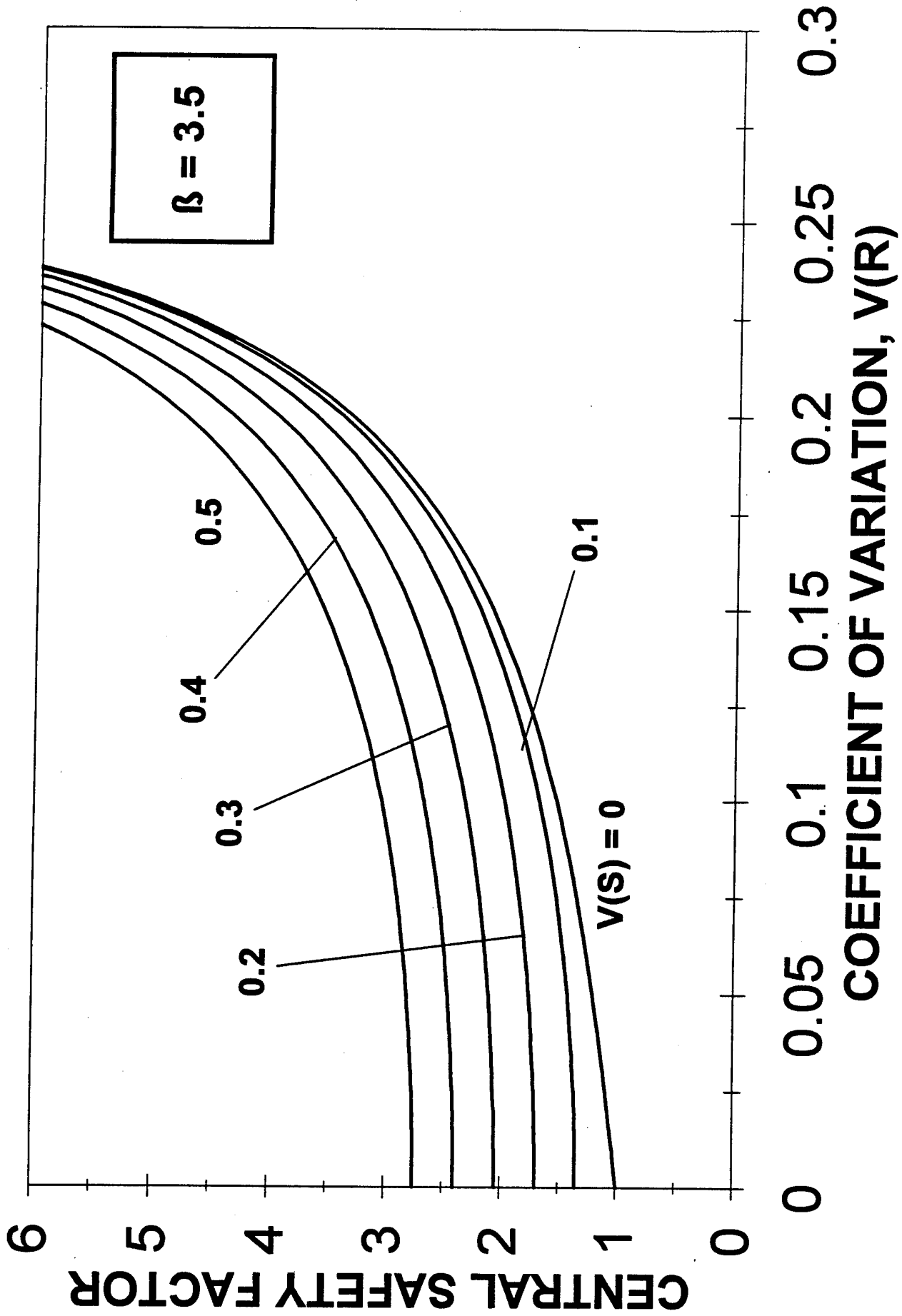

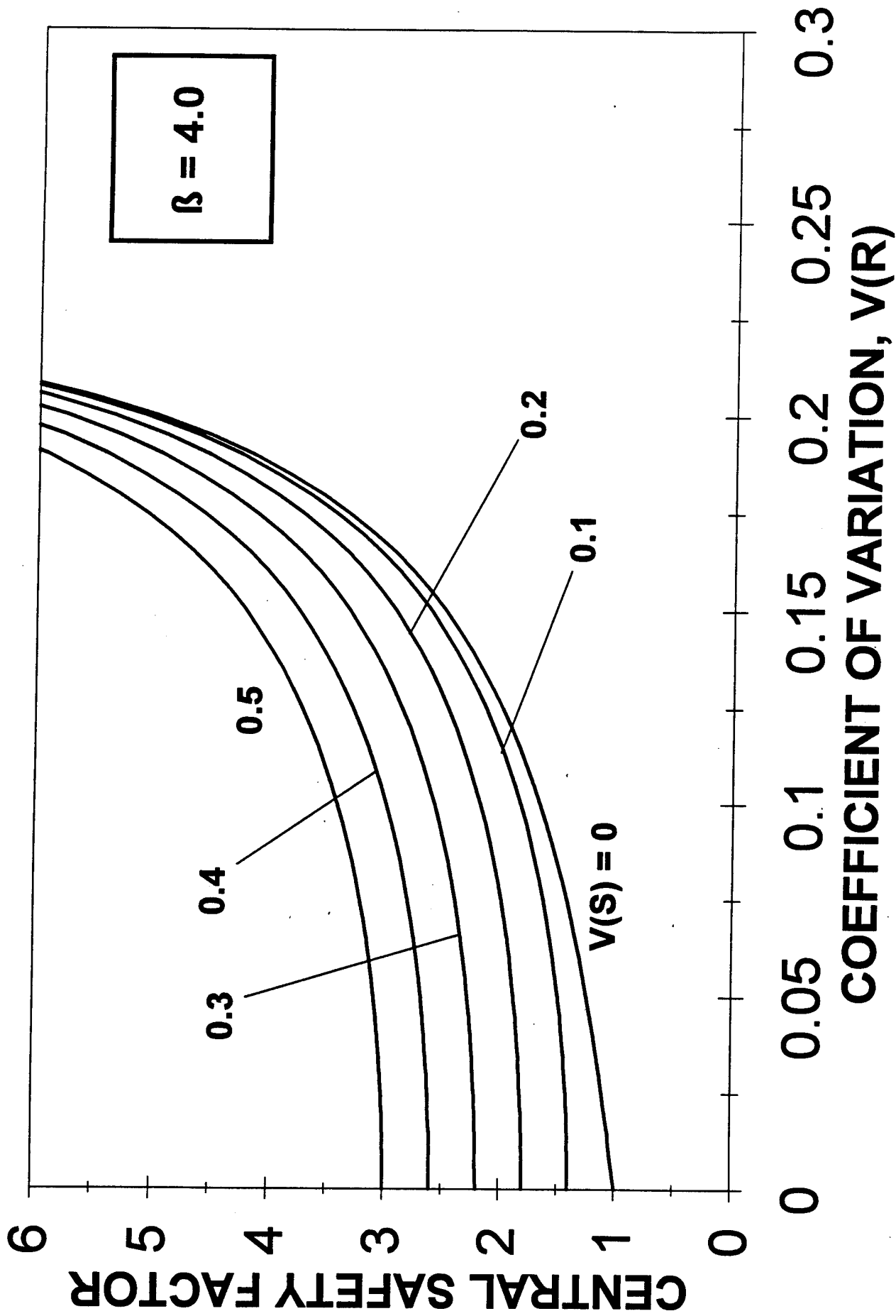

R: NORMAL, S: NORMAL

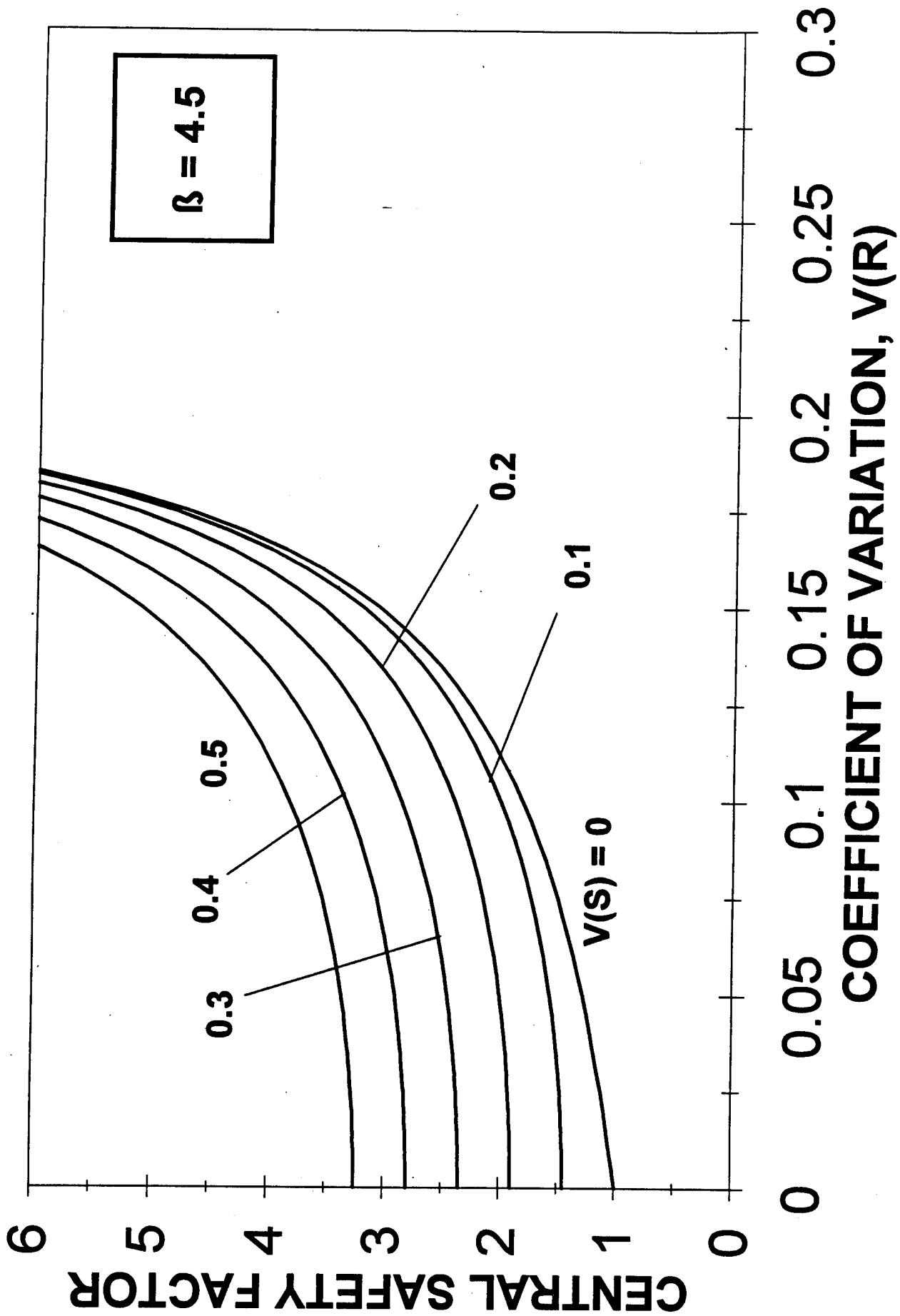

R: NORMAL, S: NORMAL

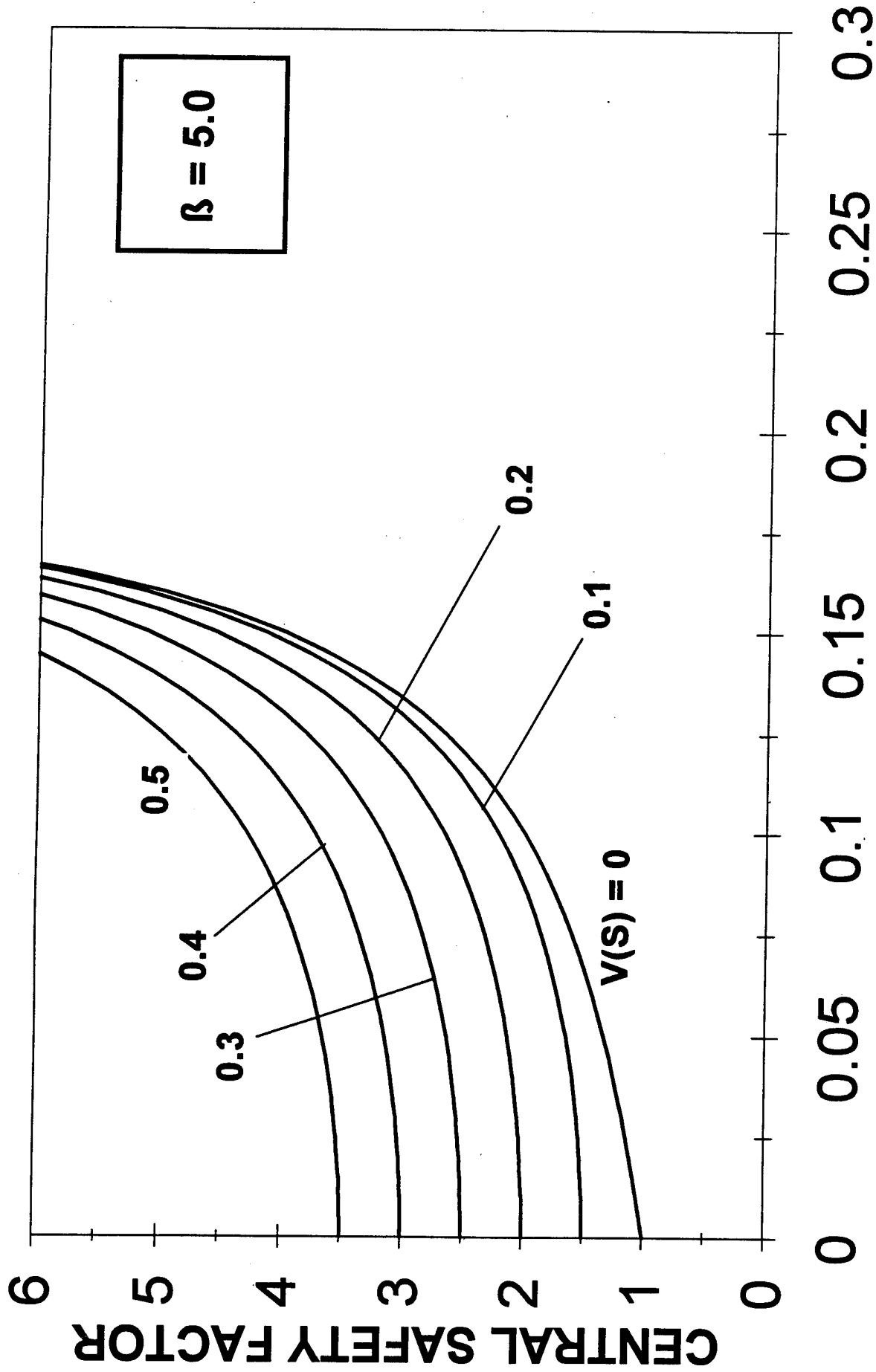

COEFFICIENT OF VARIATION, $V(R)$

R: NORMAL, S: NORMAL

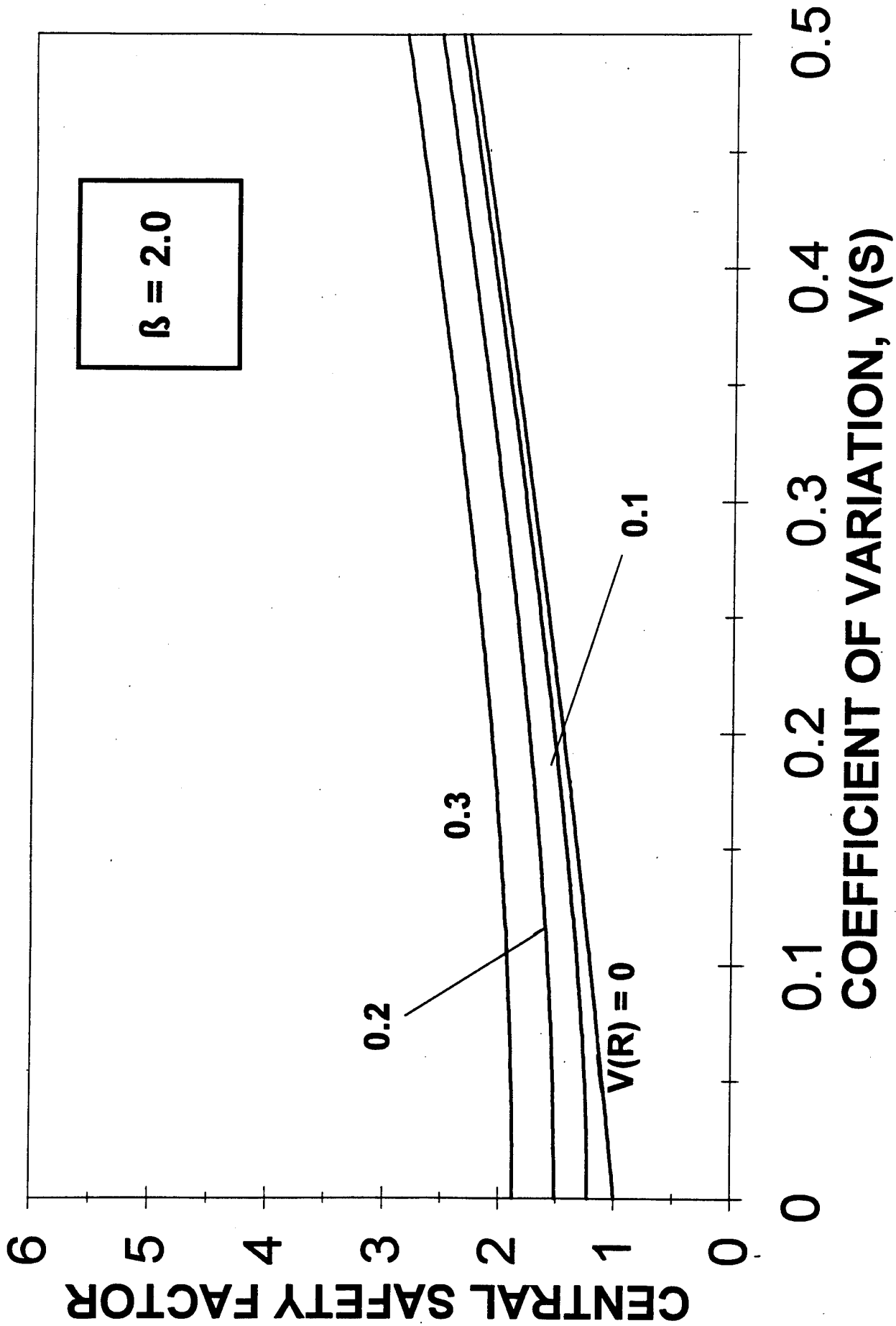

R: LOG-NORMAL, S: LOG-NORMAL

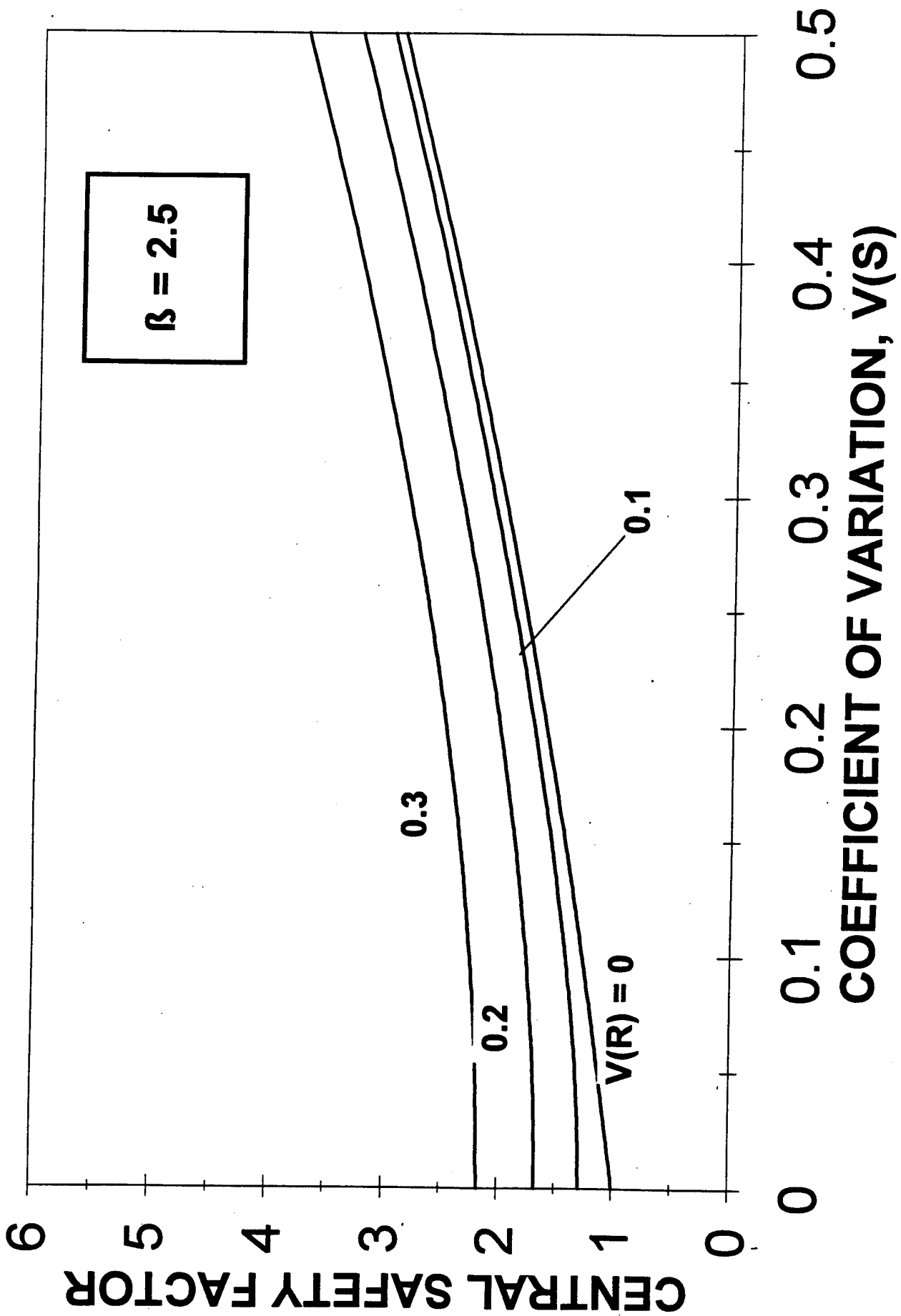

R: LOG-NORMAL, S: LOG-NORMAL

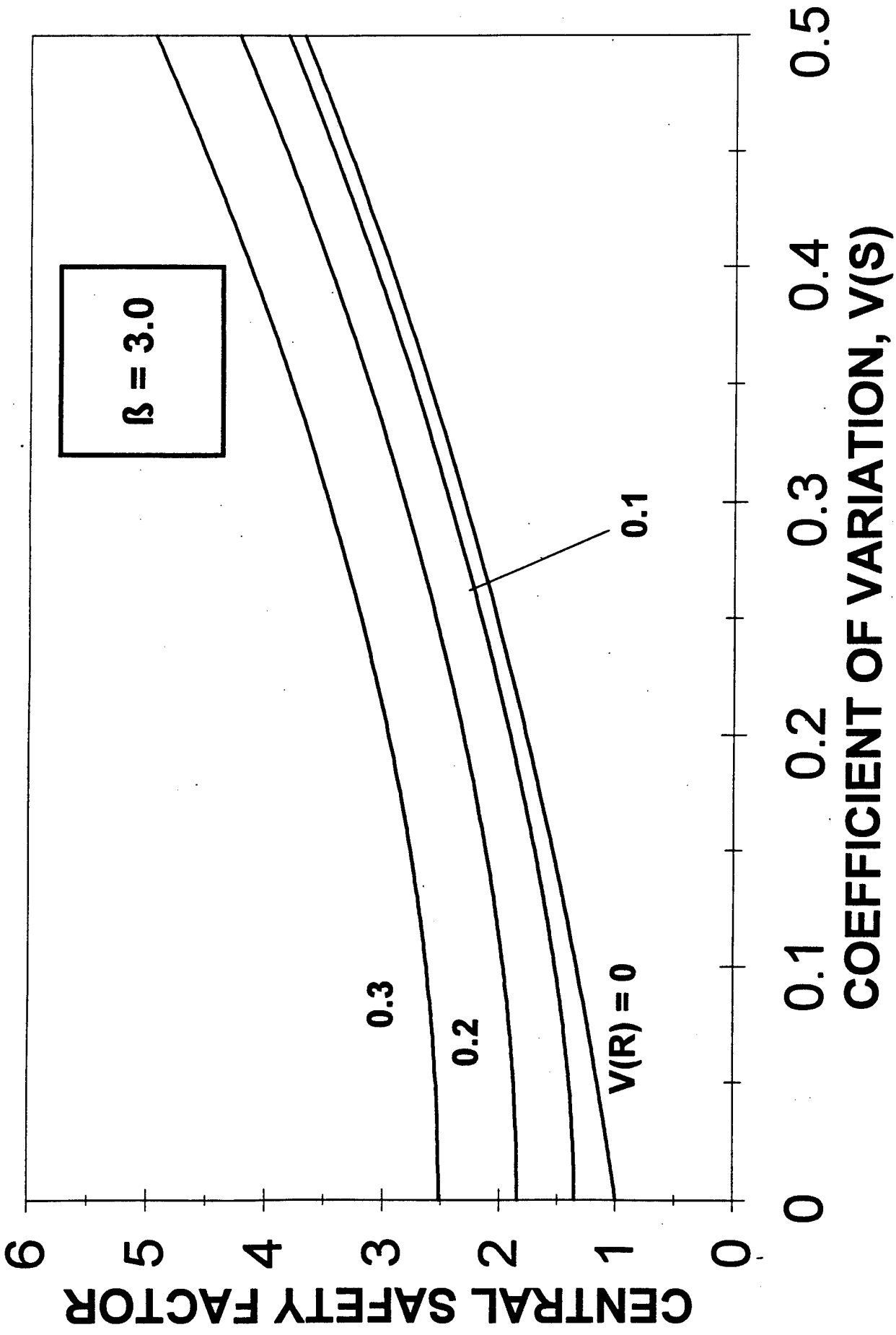

R: LOG-NORMAL, S: LOG-NORMAL

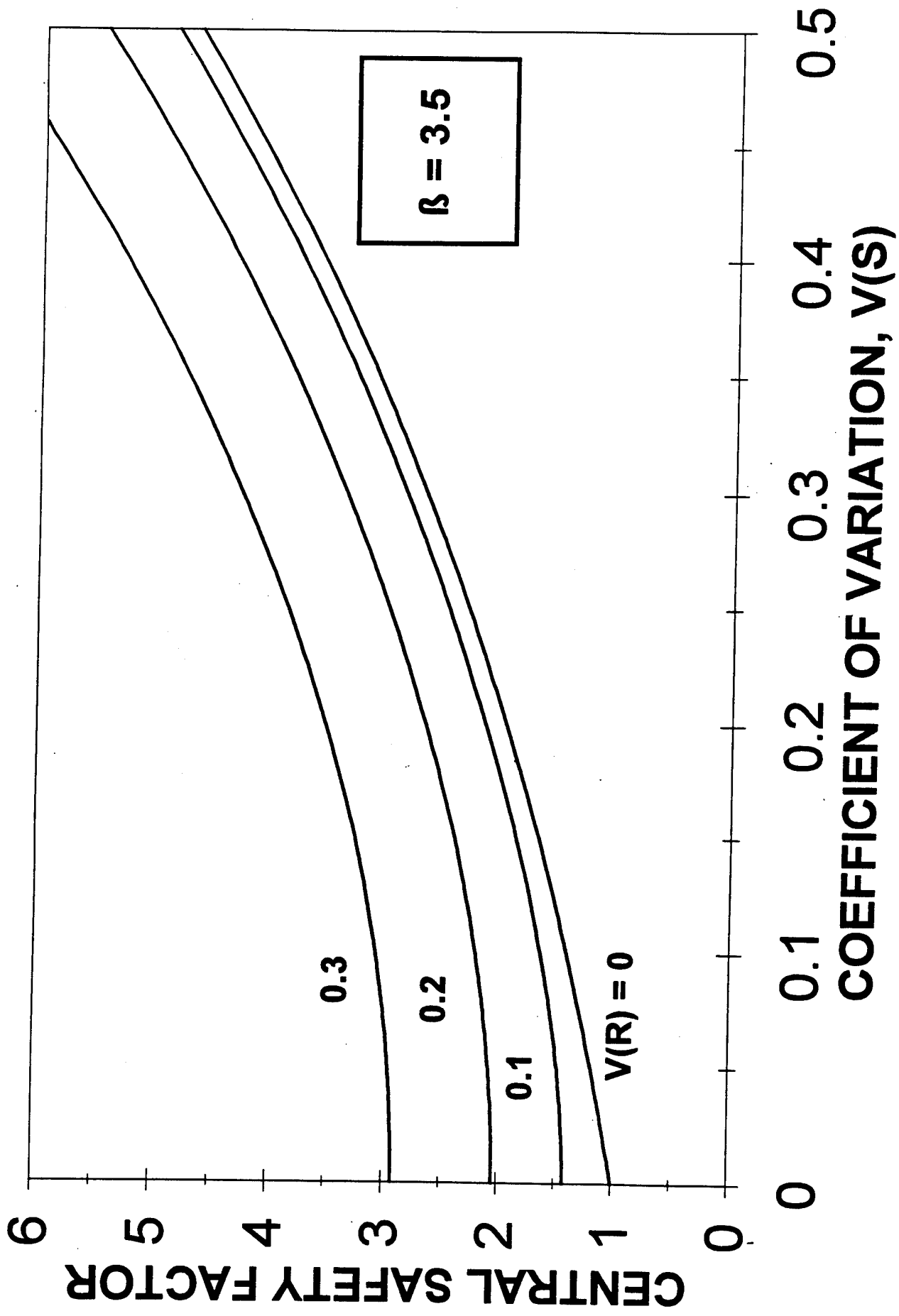

R: LOG-NORMAL, S: LOG-NORMAL

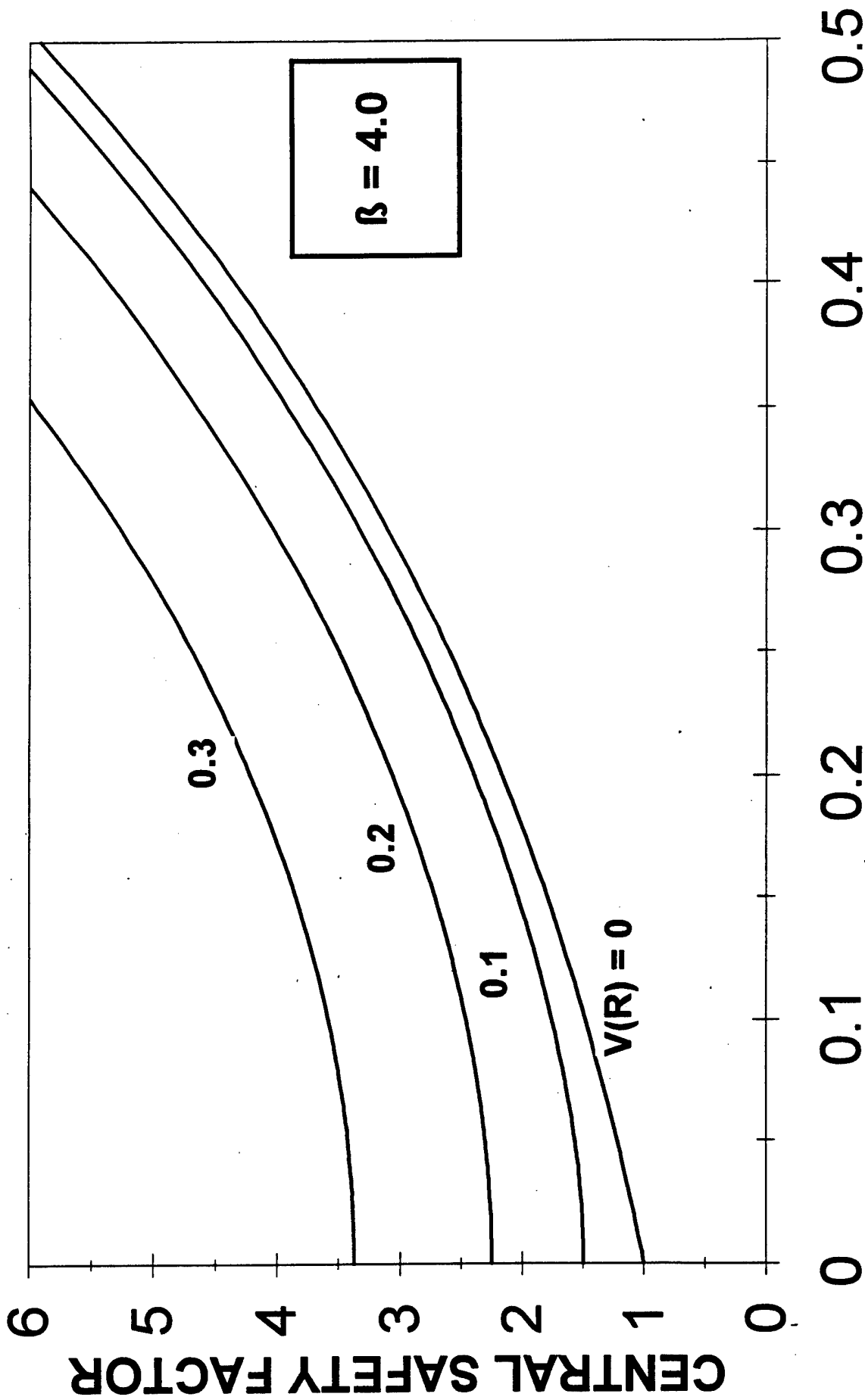

R: LOG-NORMAL, S: LOG-NORMAL

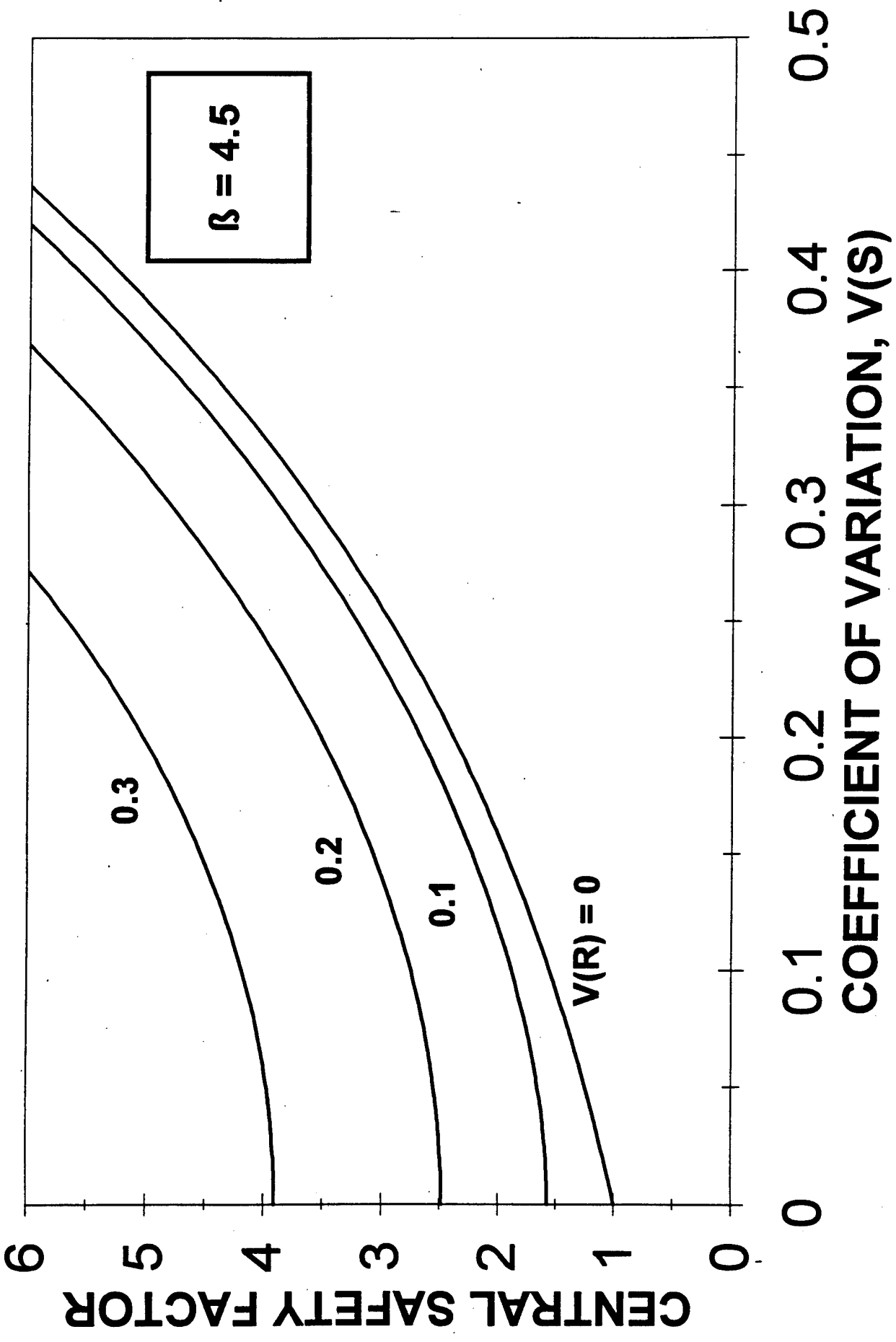

R: LOG-NORMAL, S: LOG-NORMAL

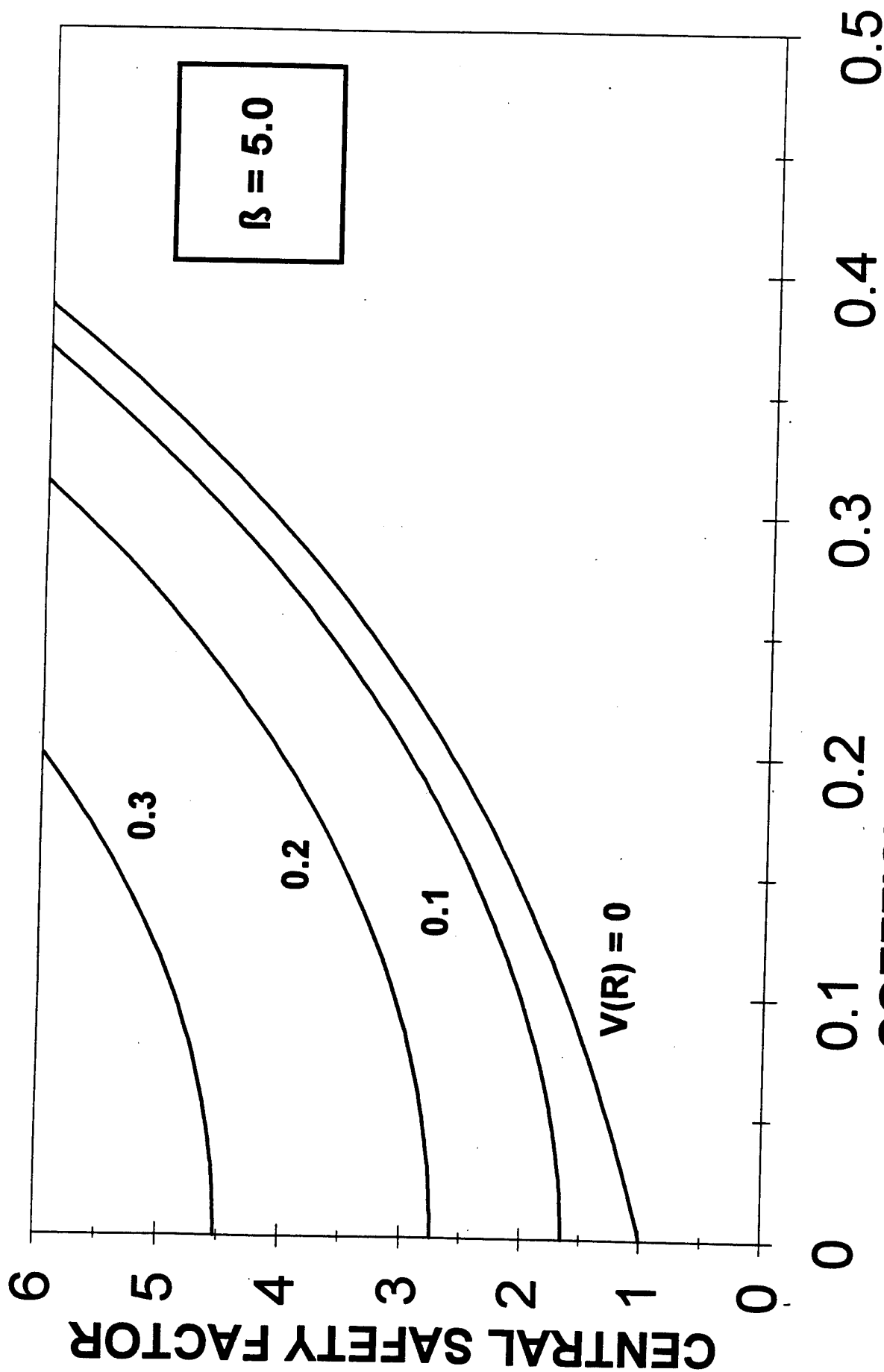

COEFFICIENT OF VARIATION, $V(S)$

R: LOG-NORMAL, S: LOG-NORMAL

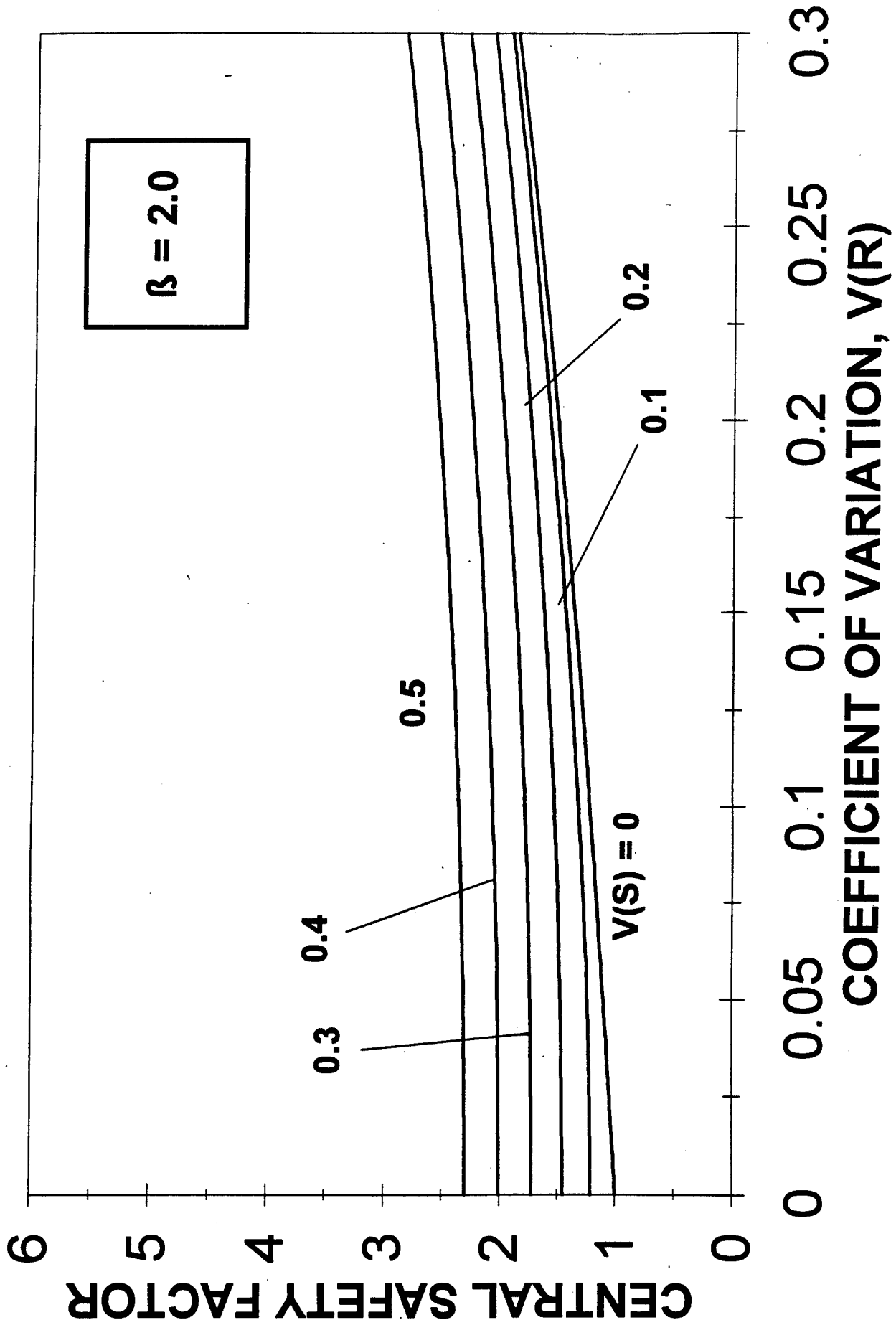

R: LOG-NORMAL, S: LOG-NORMAL

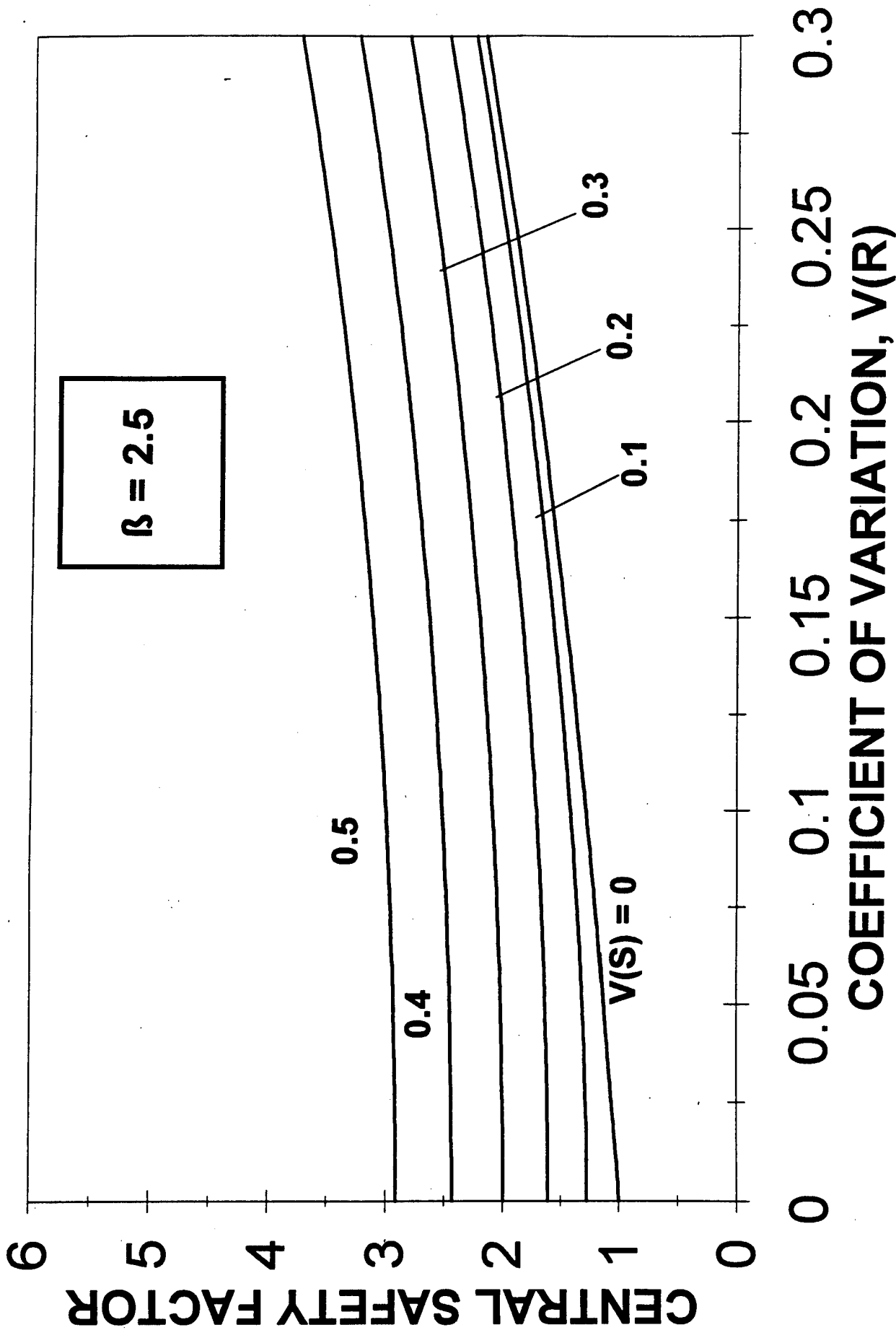

R: LOG-NORMAL, S: LOG-NORMAL

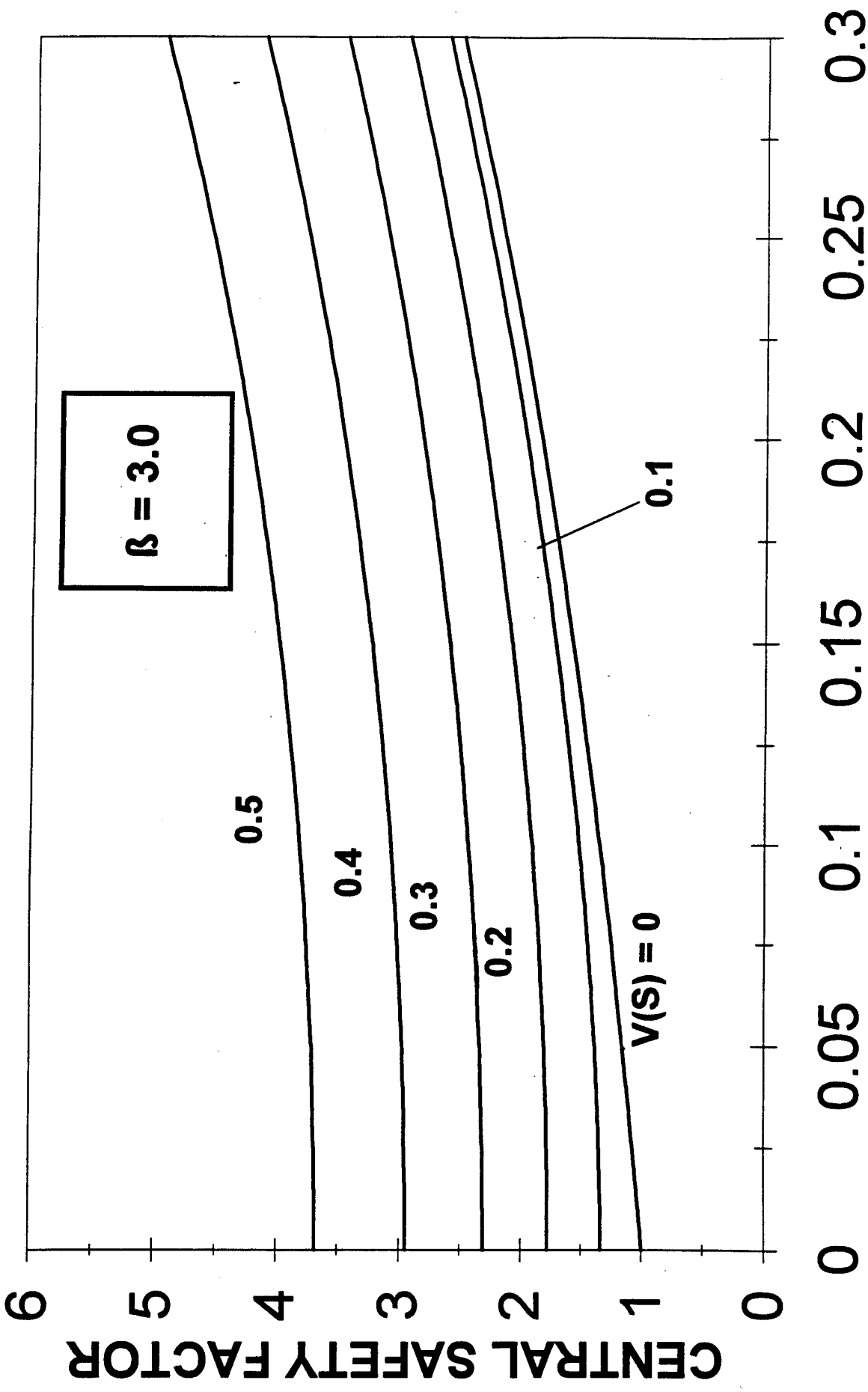

R: LOG-NORMAL, S: LOG-NORMAL

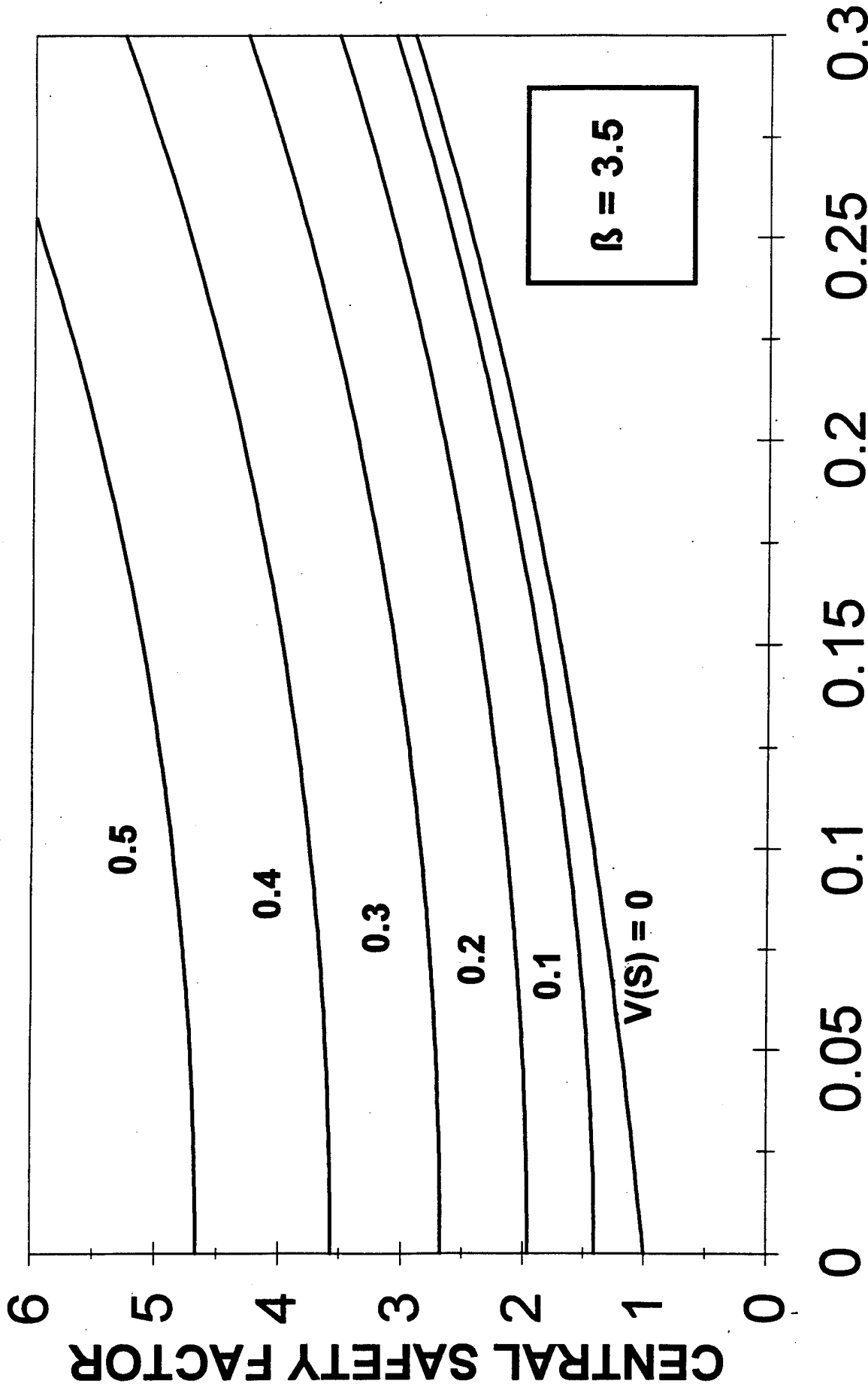

R: LOG-NORMAL, S: LOG-NORMAL

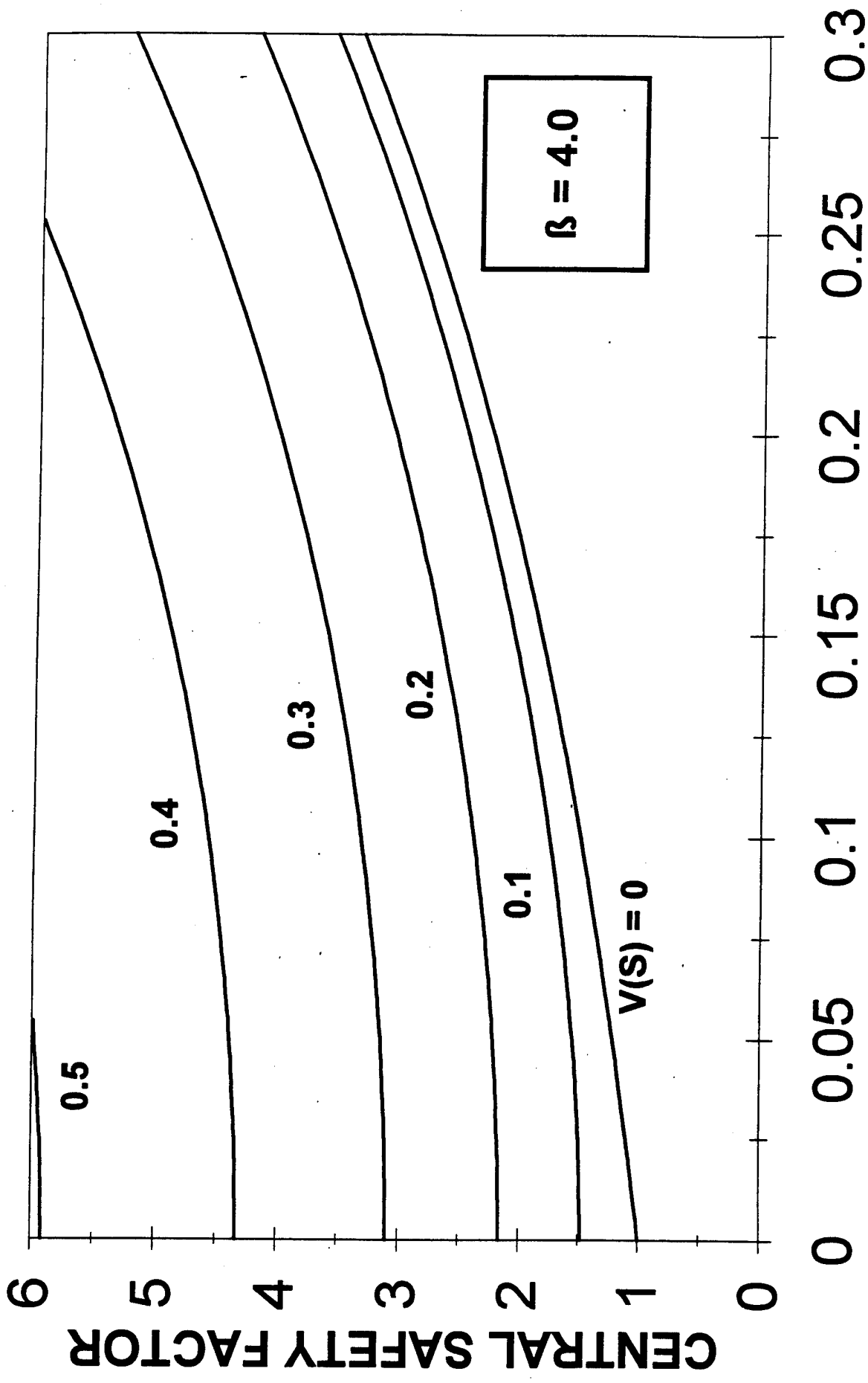

R: LOG-NORMAL, S: LOG-NORMAL

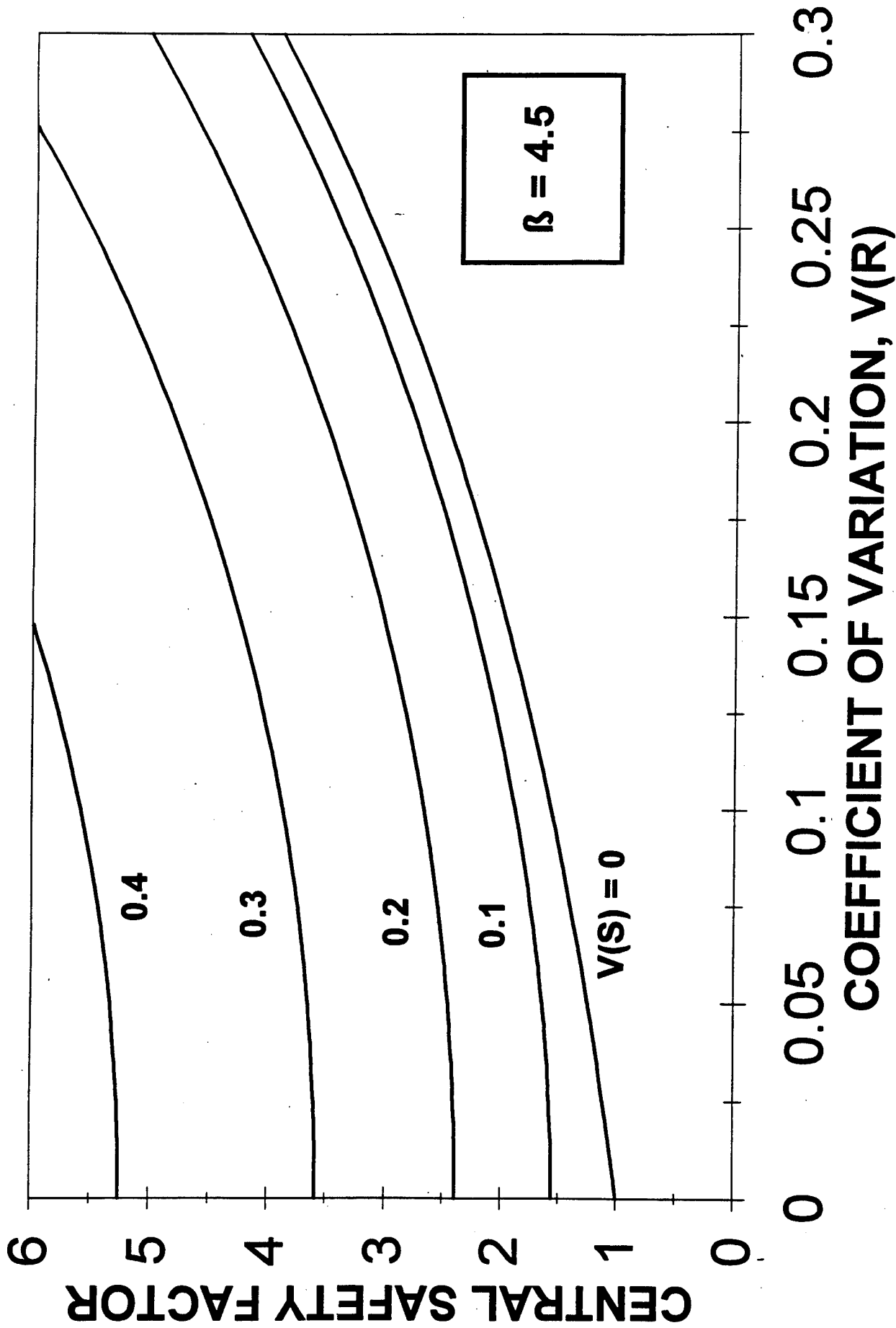

R: LOG-NORMAL, S: LOG-NORMAL

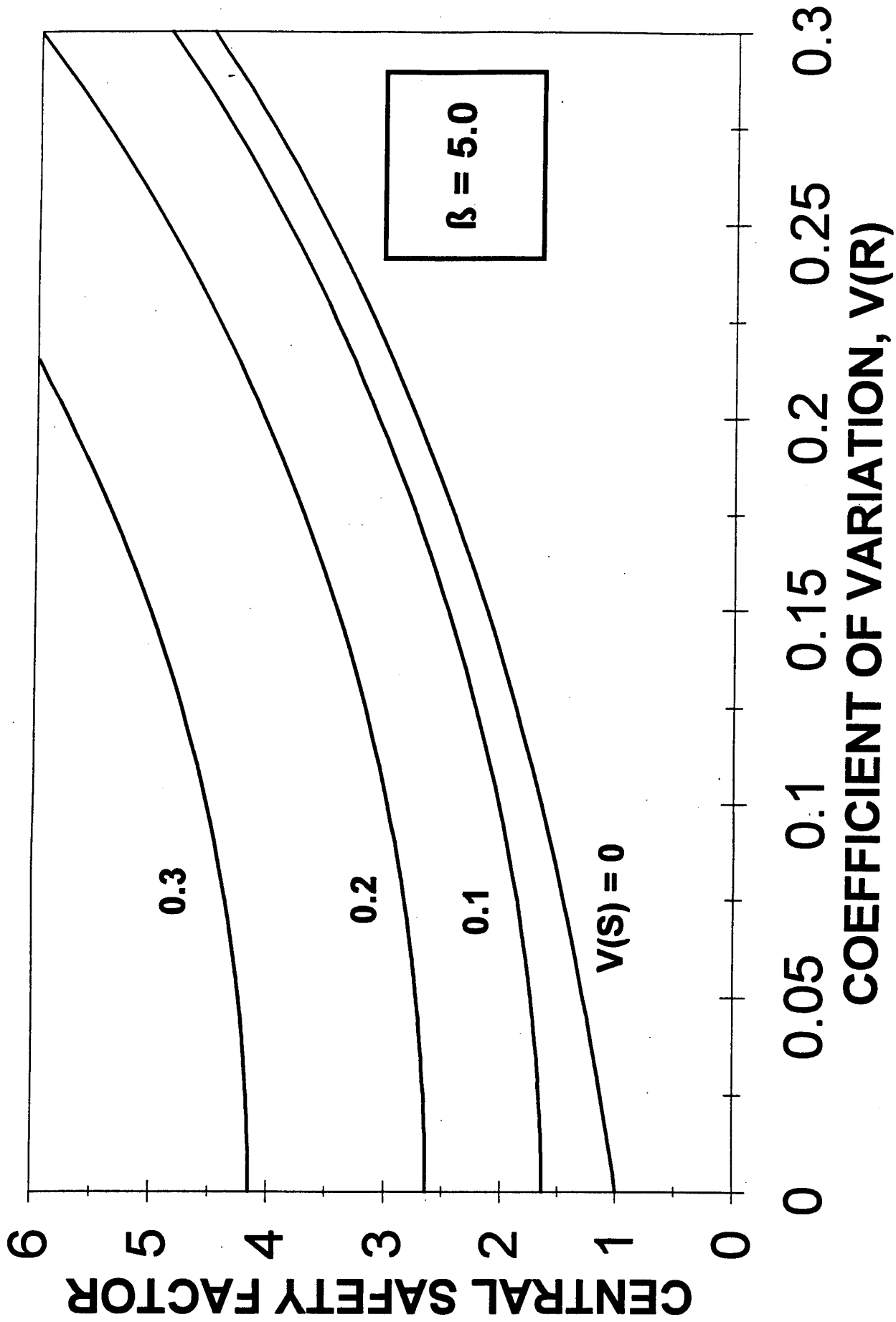

R: LOG-NORMAL, S: LOG-NORMAL

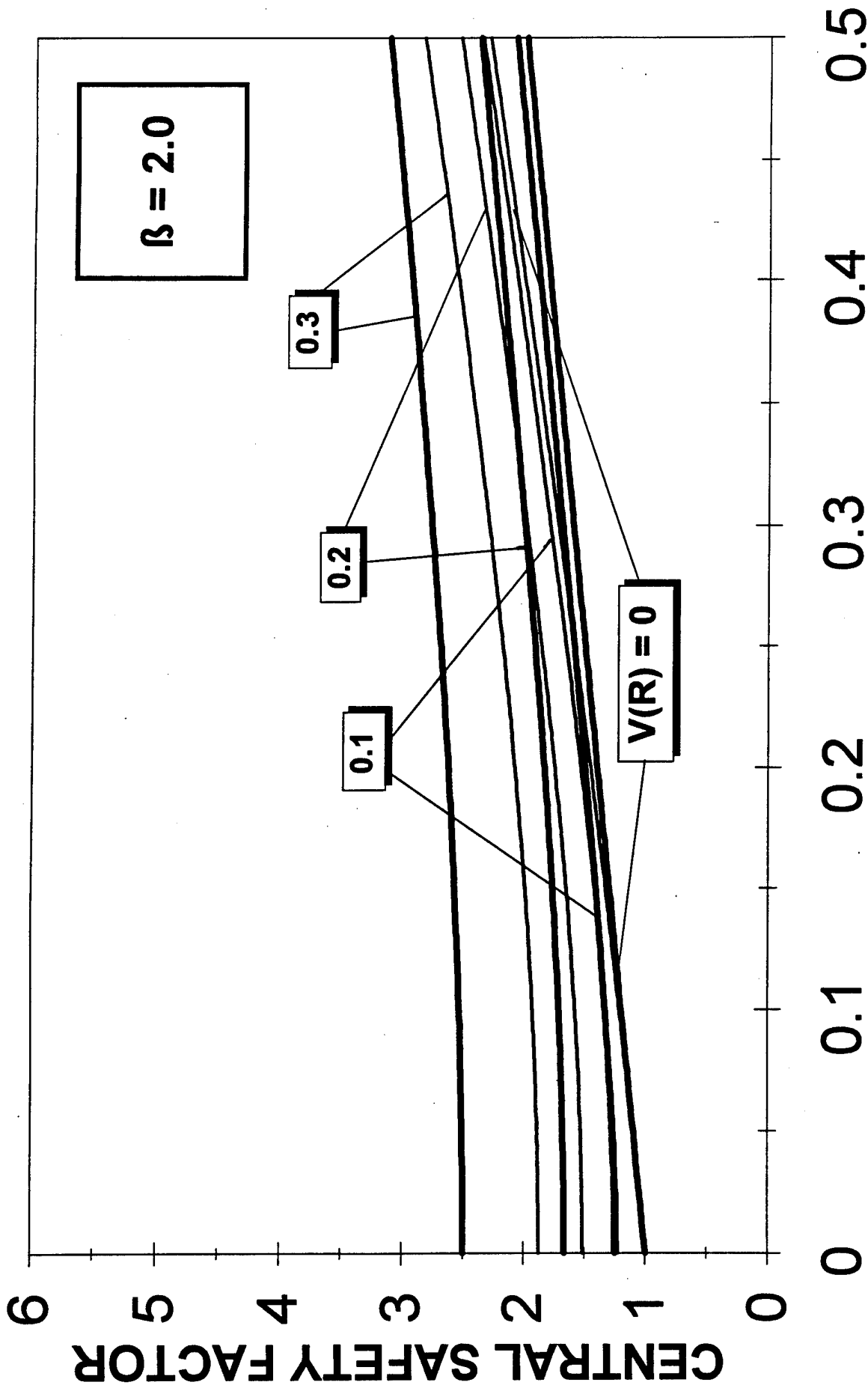

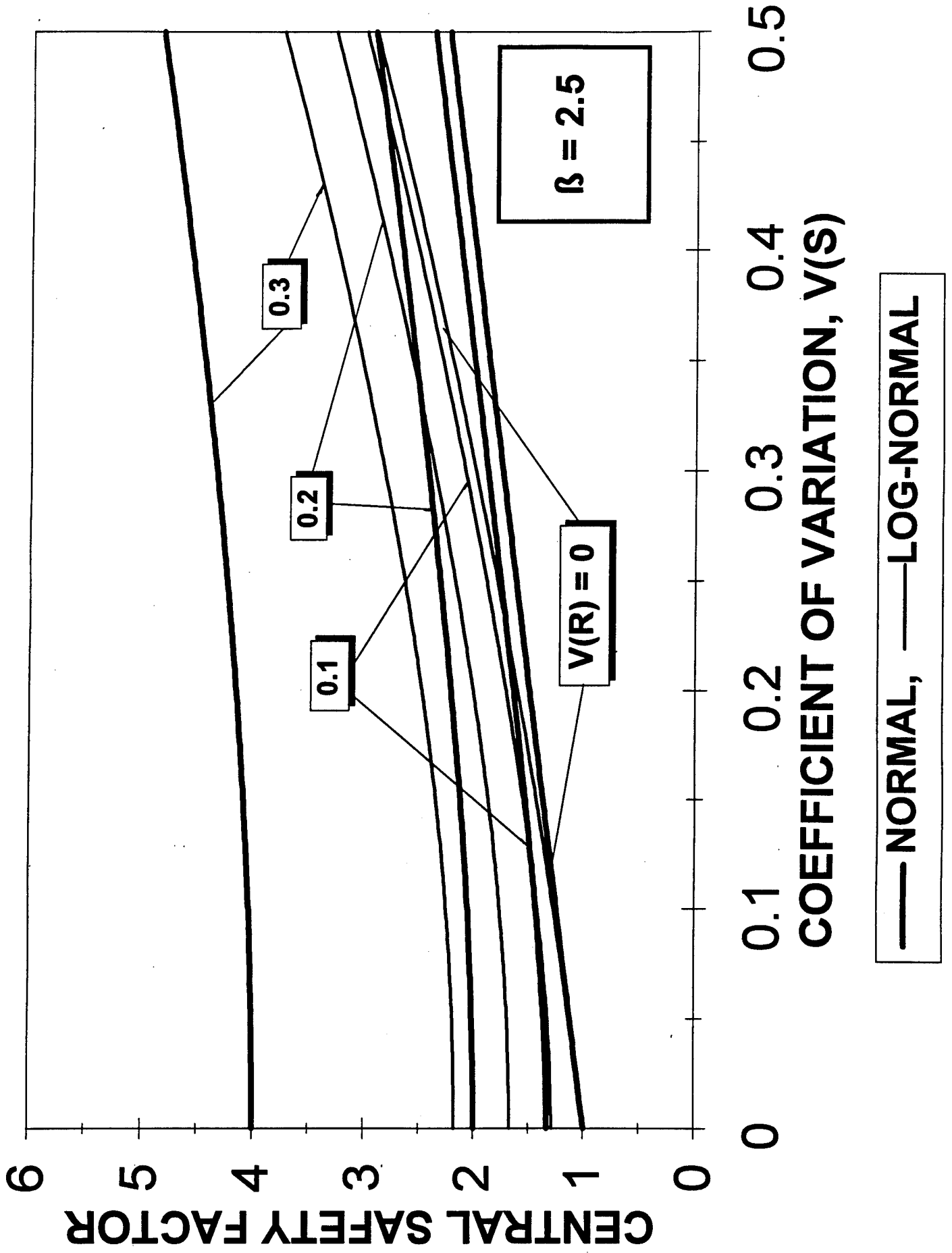

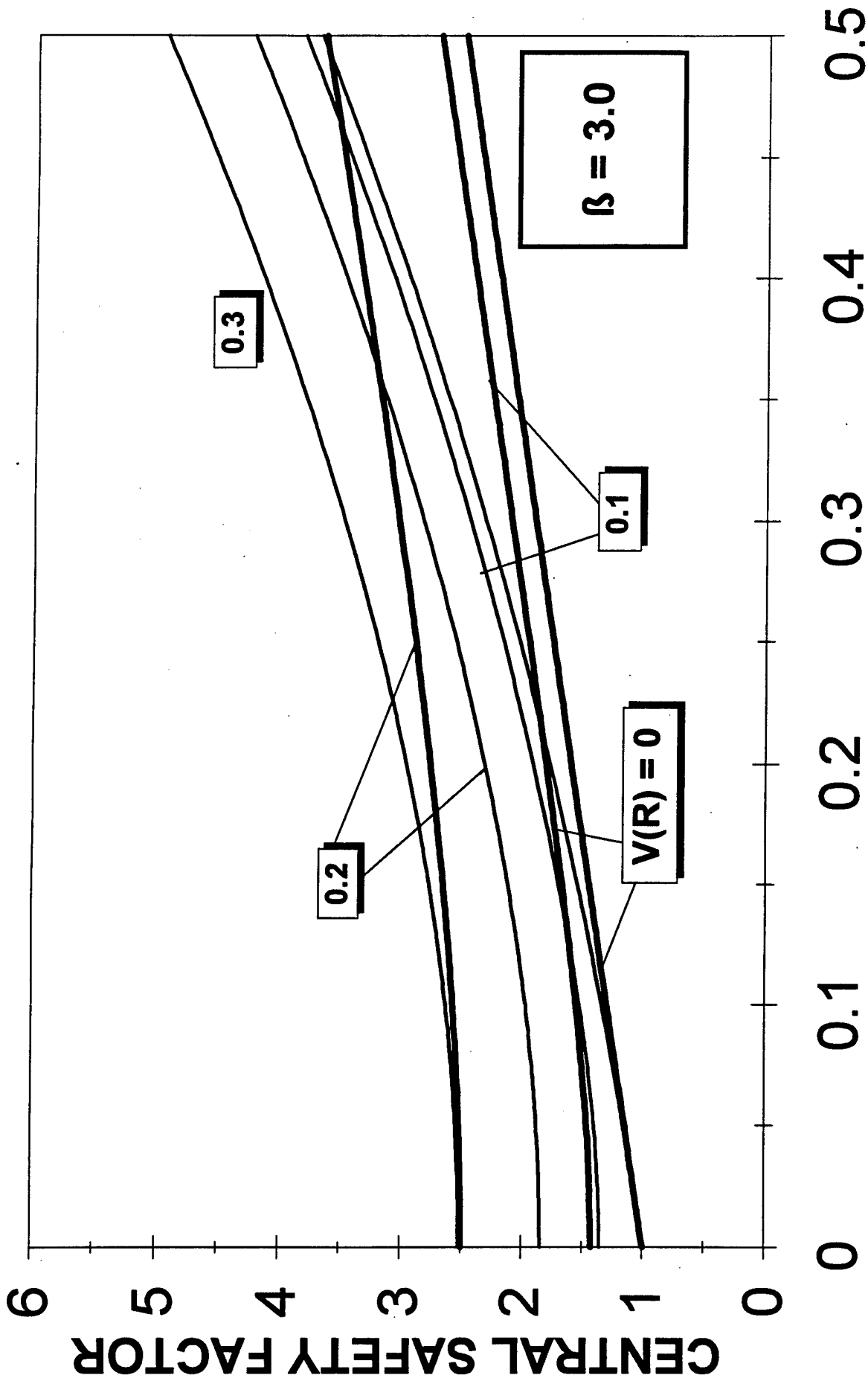

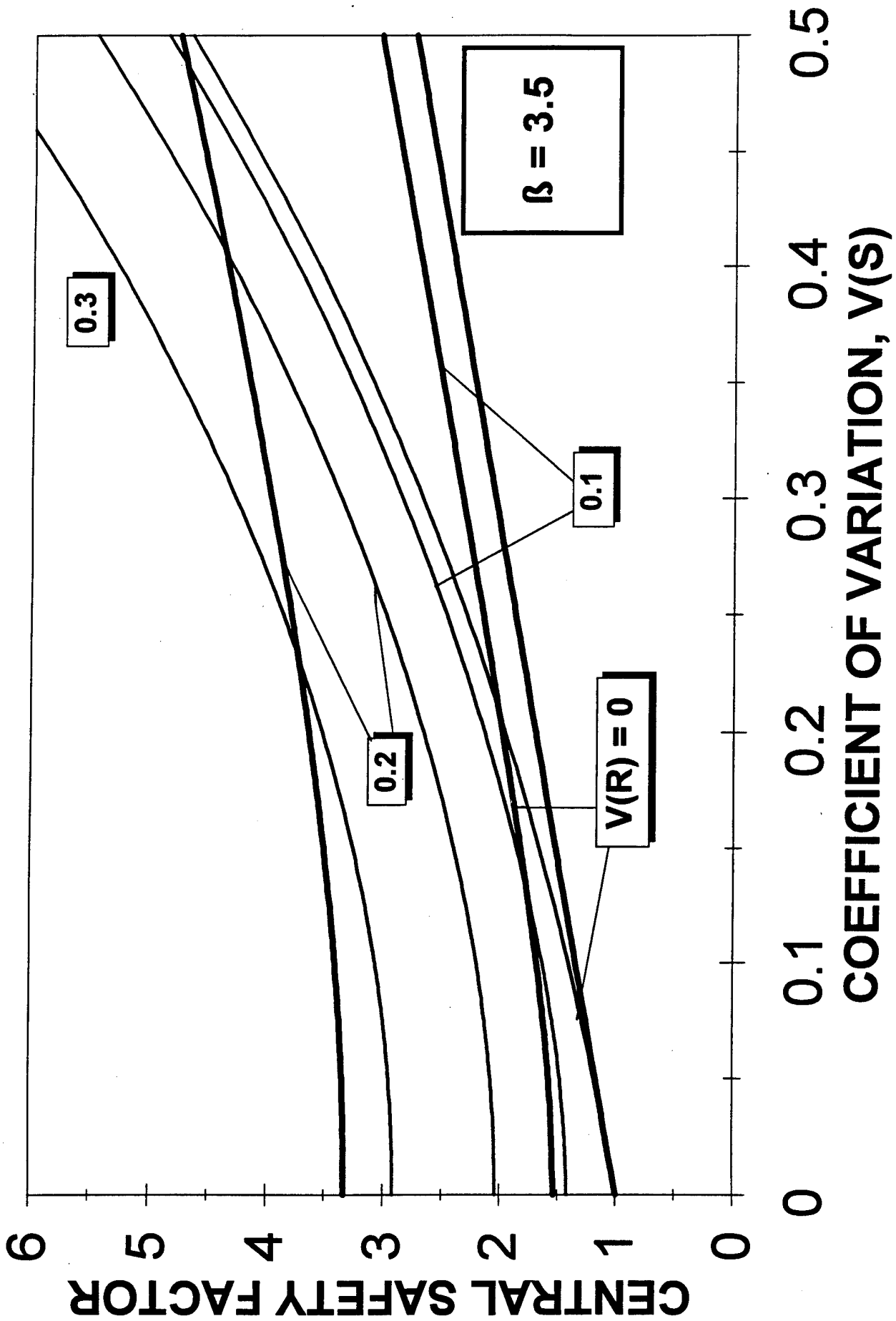

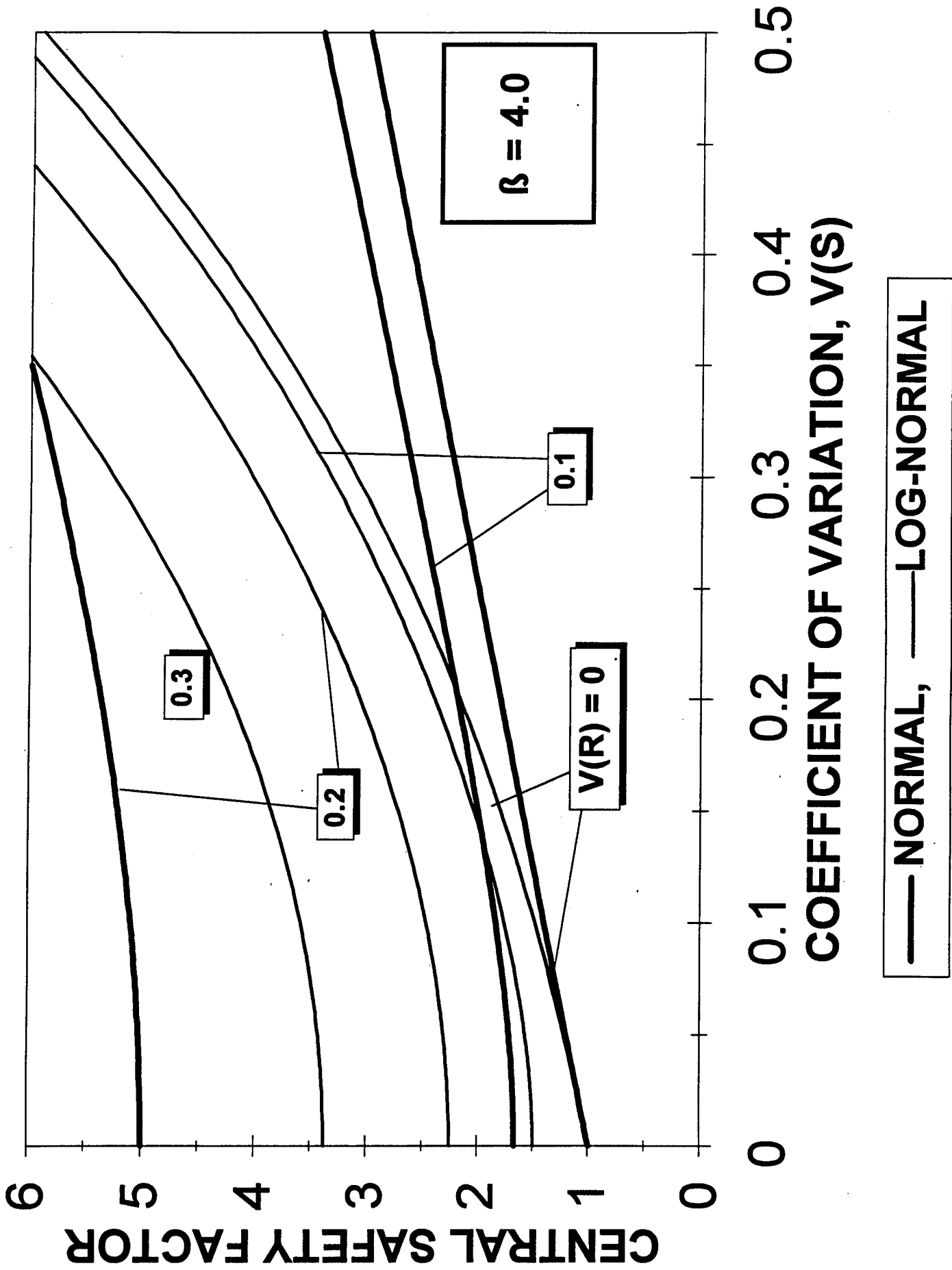

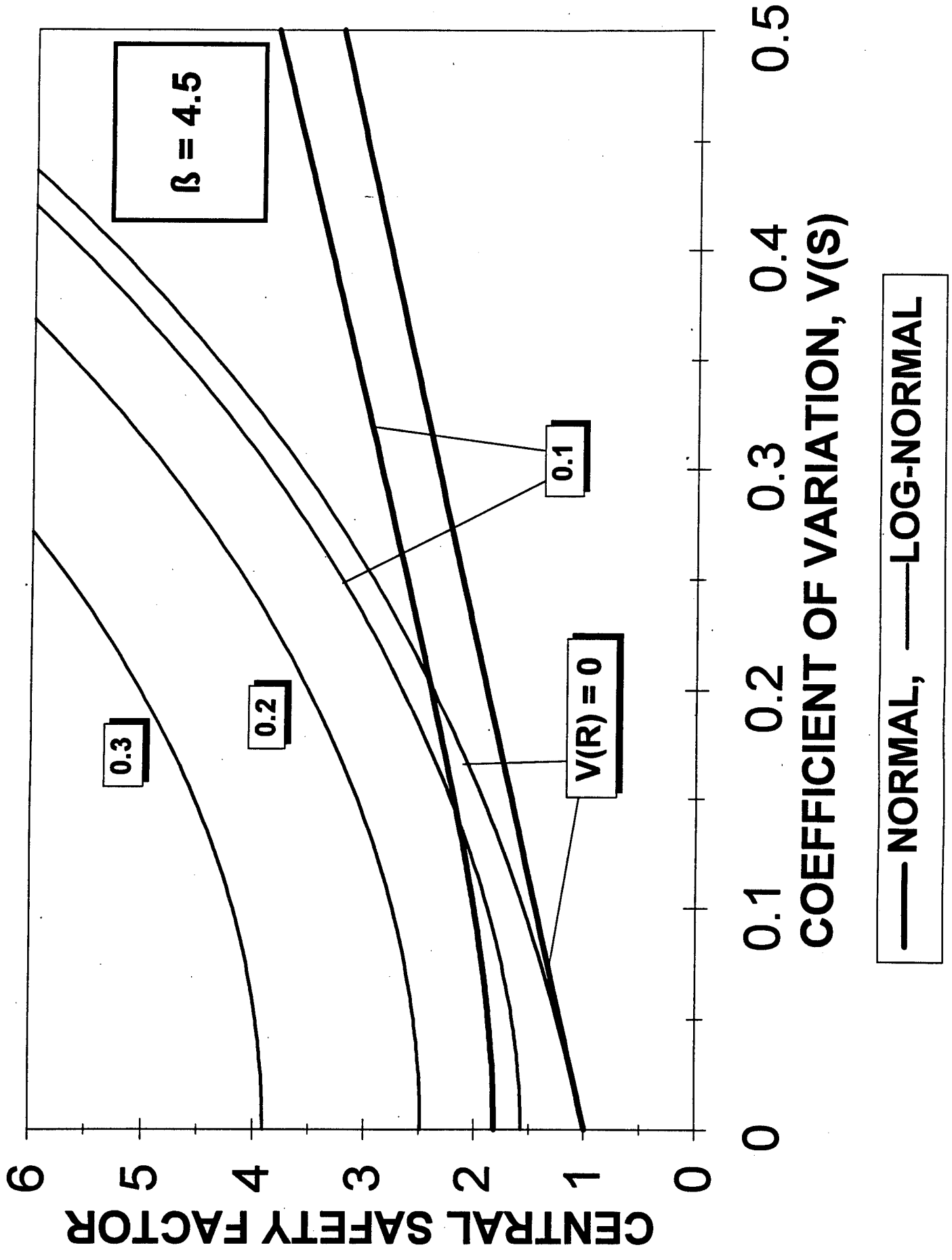

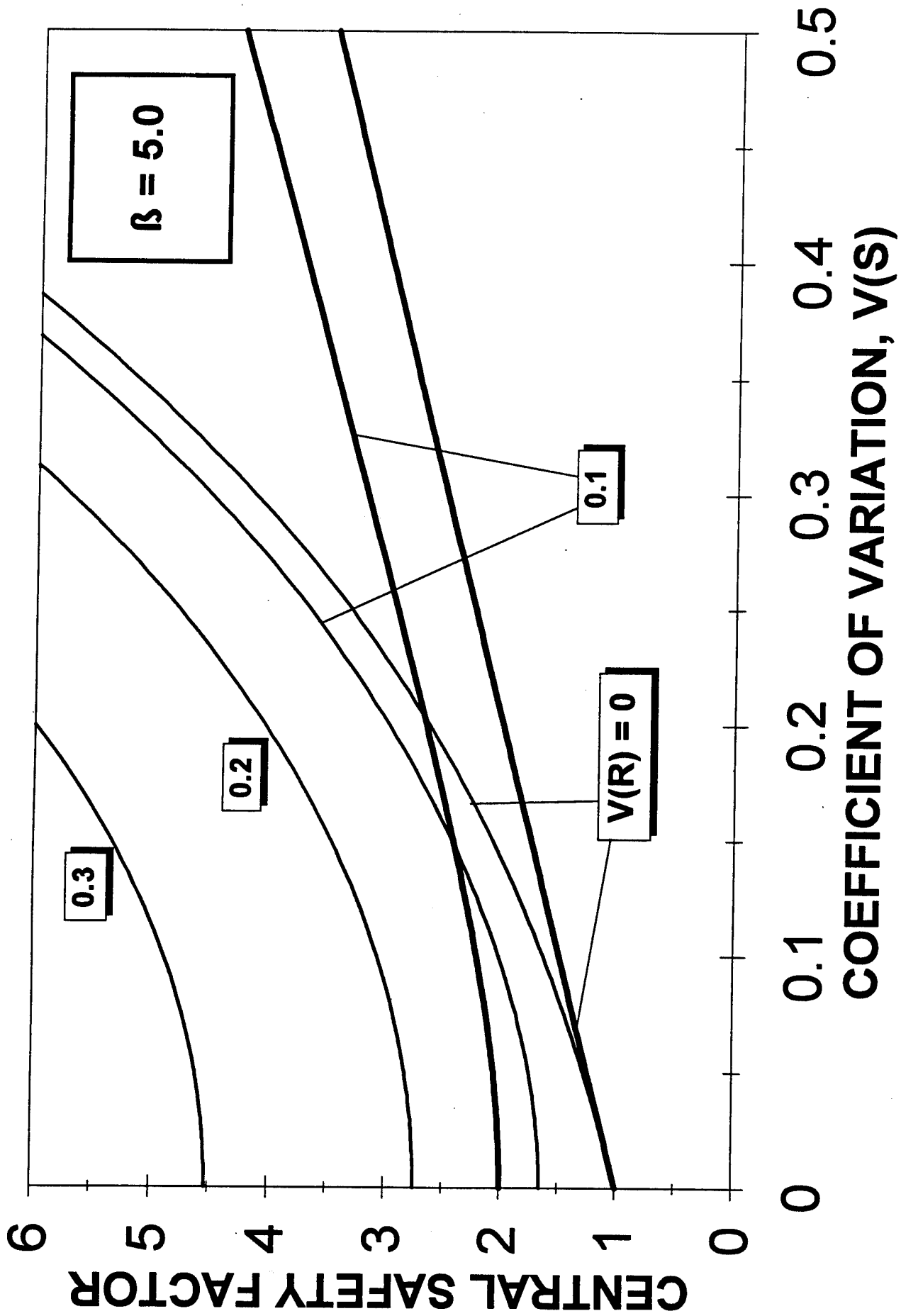

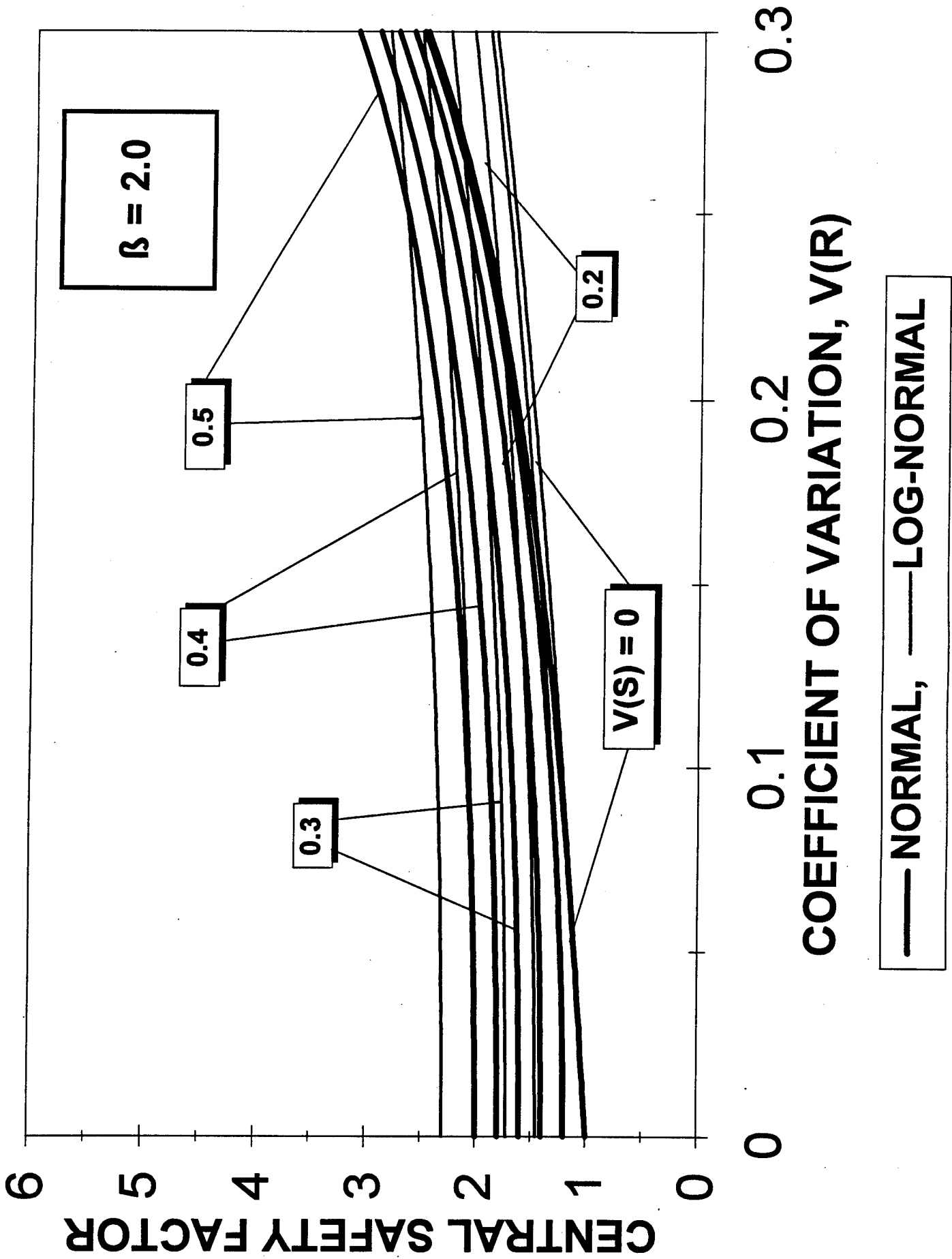

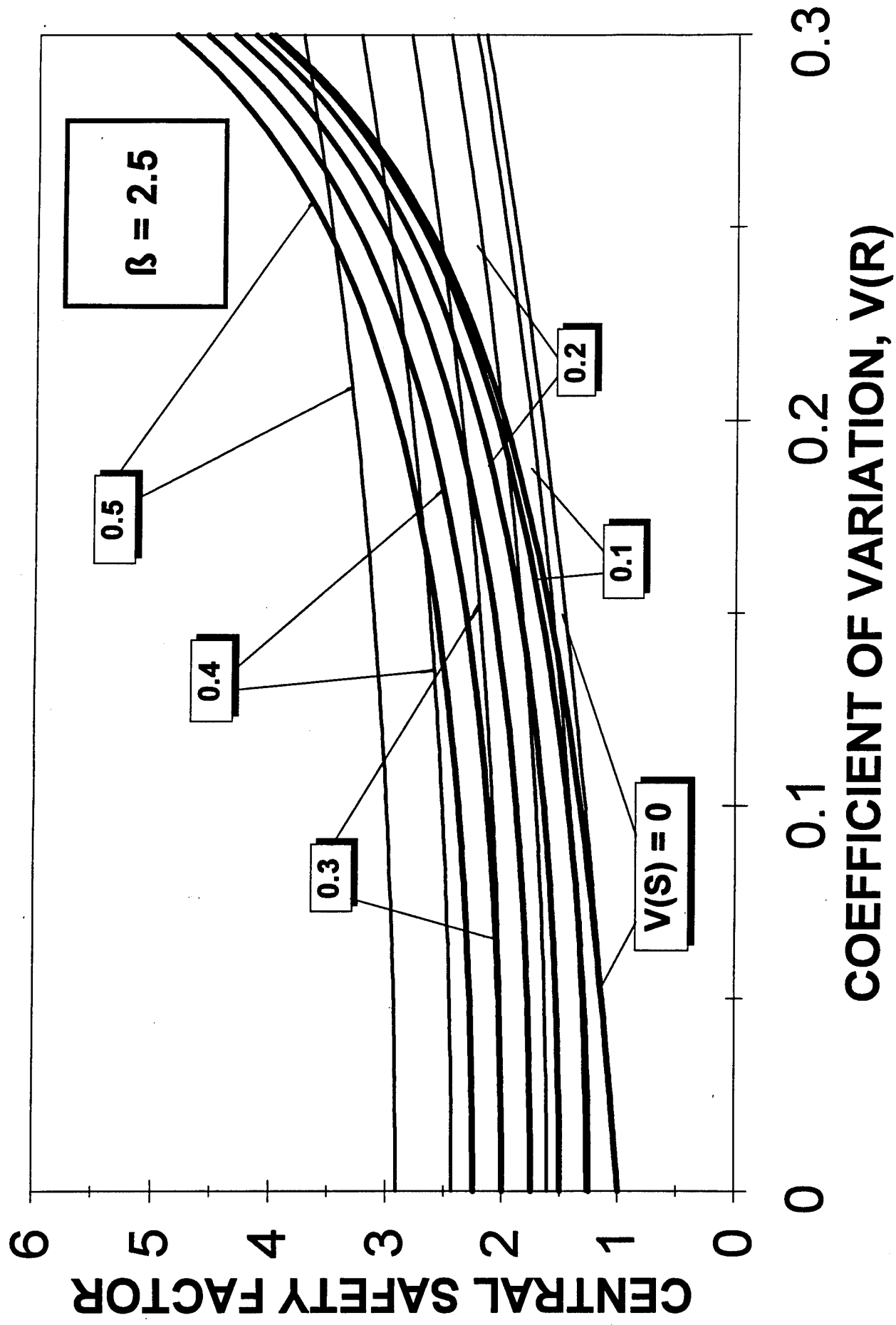

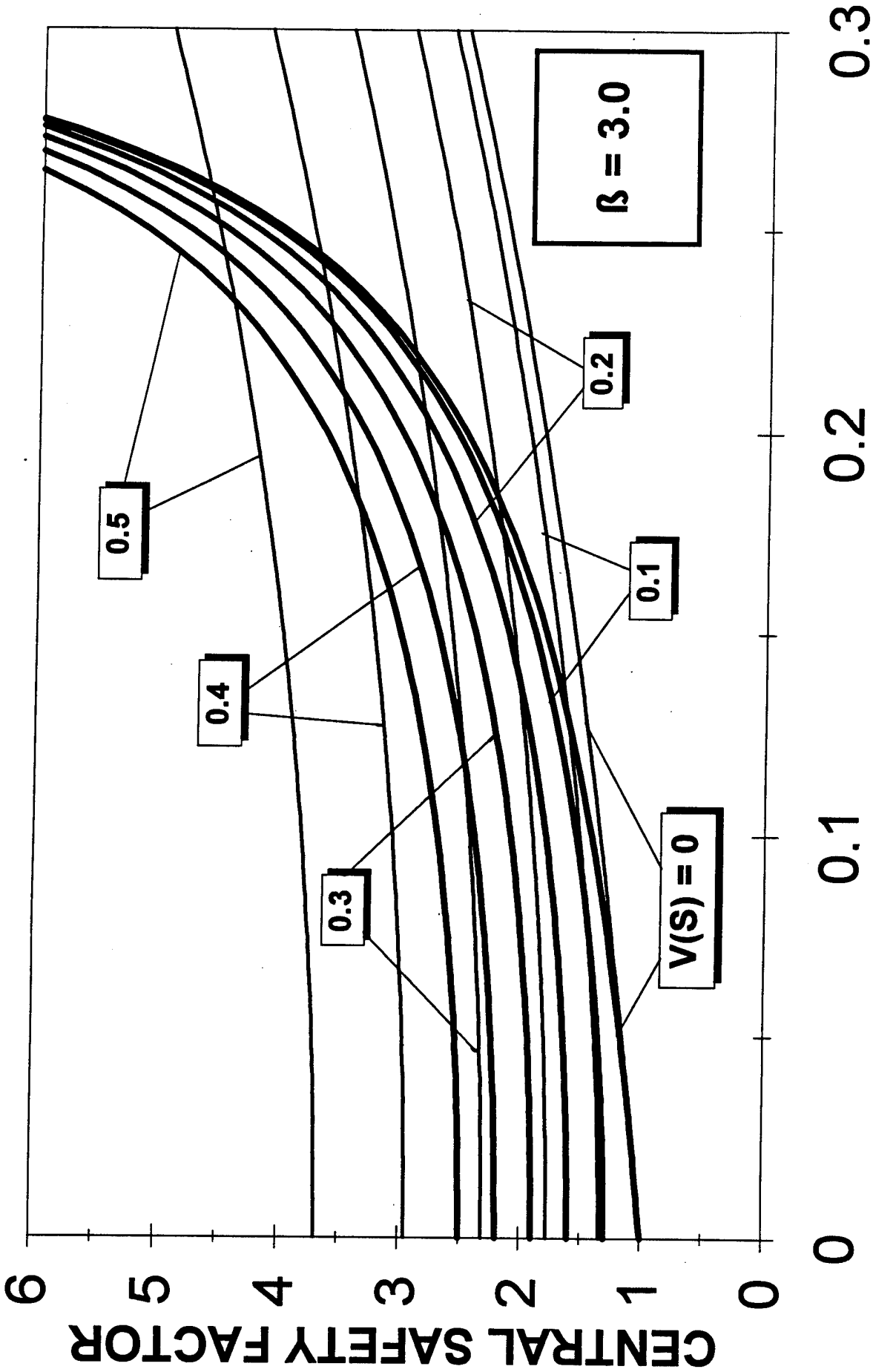

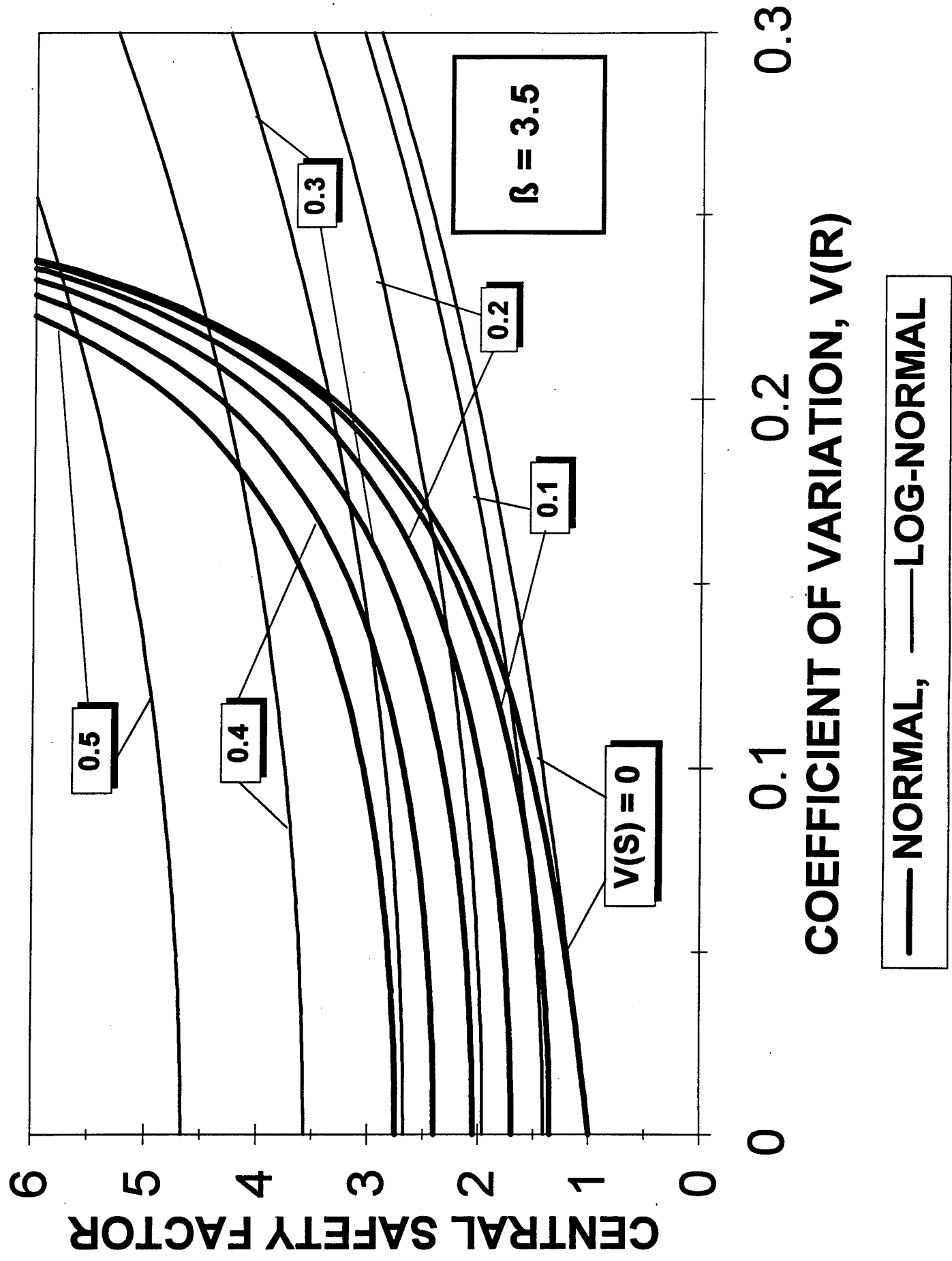

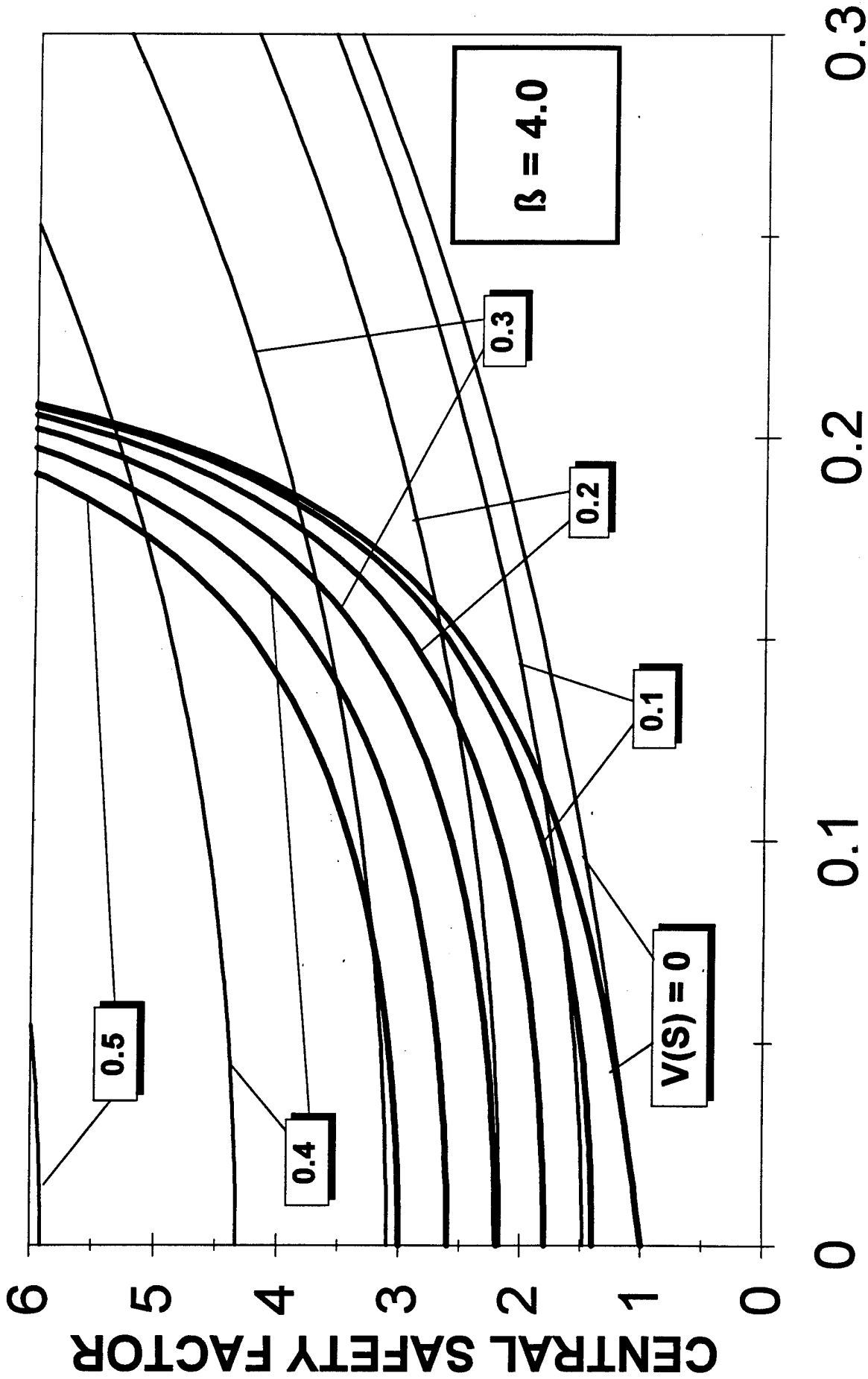

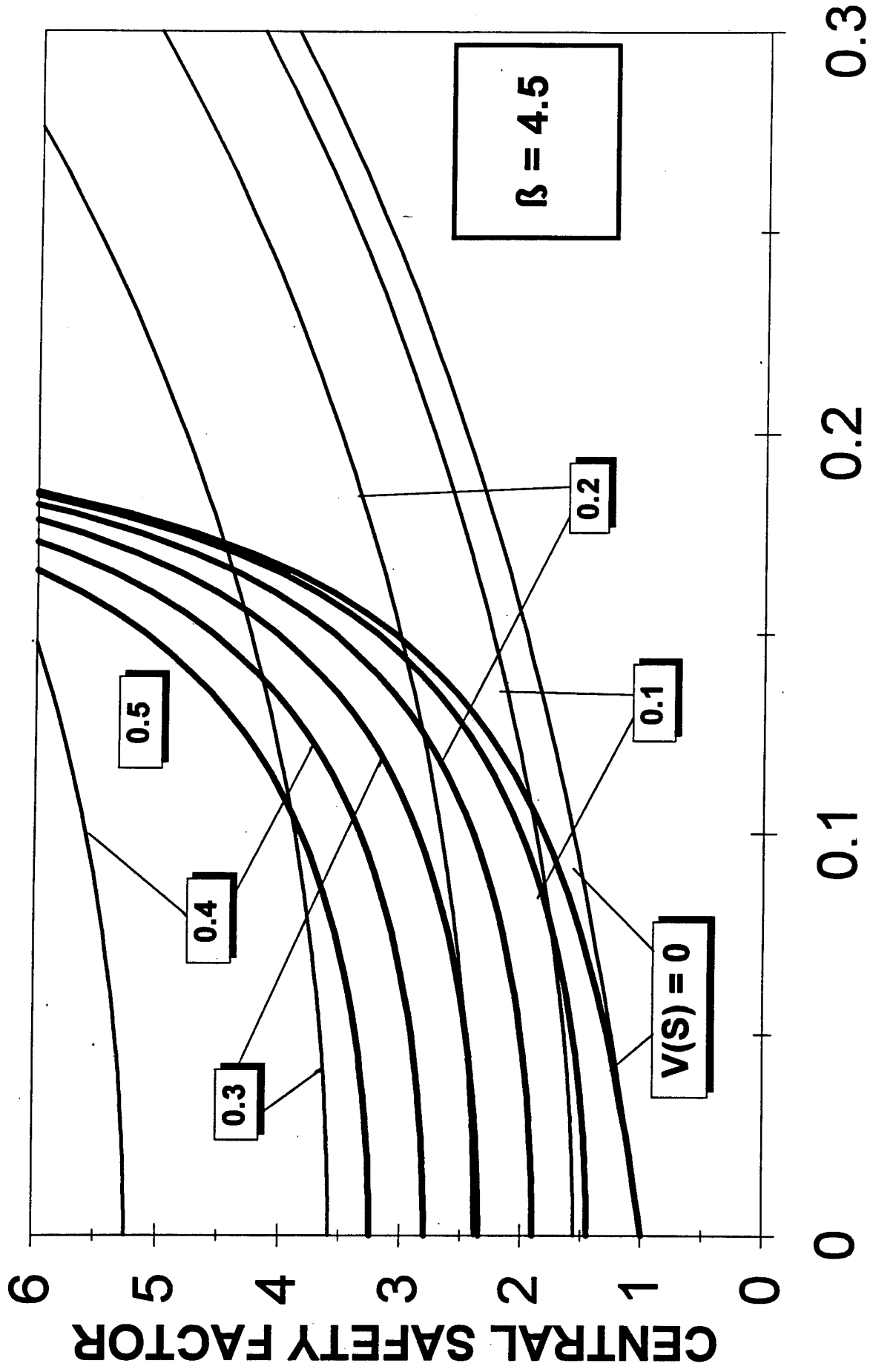

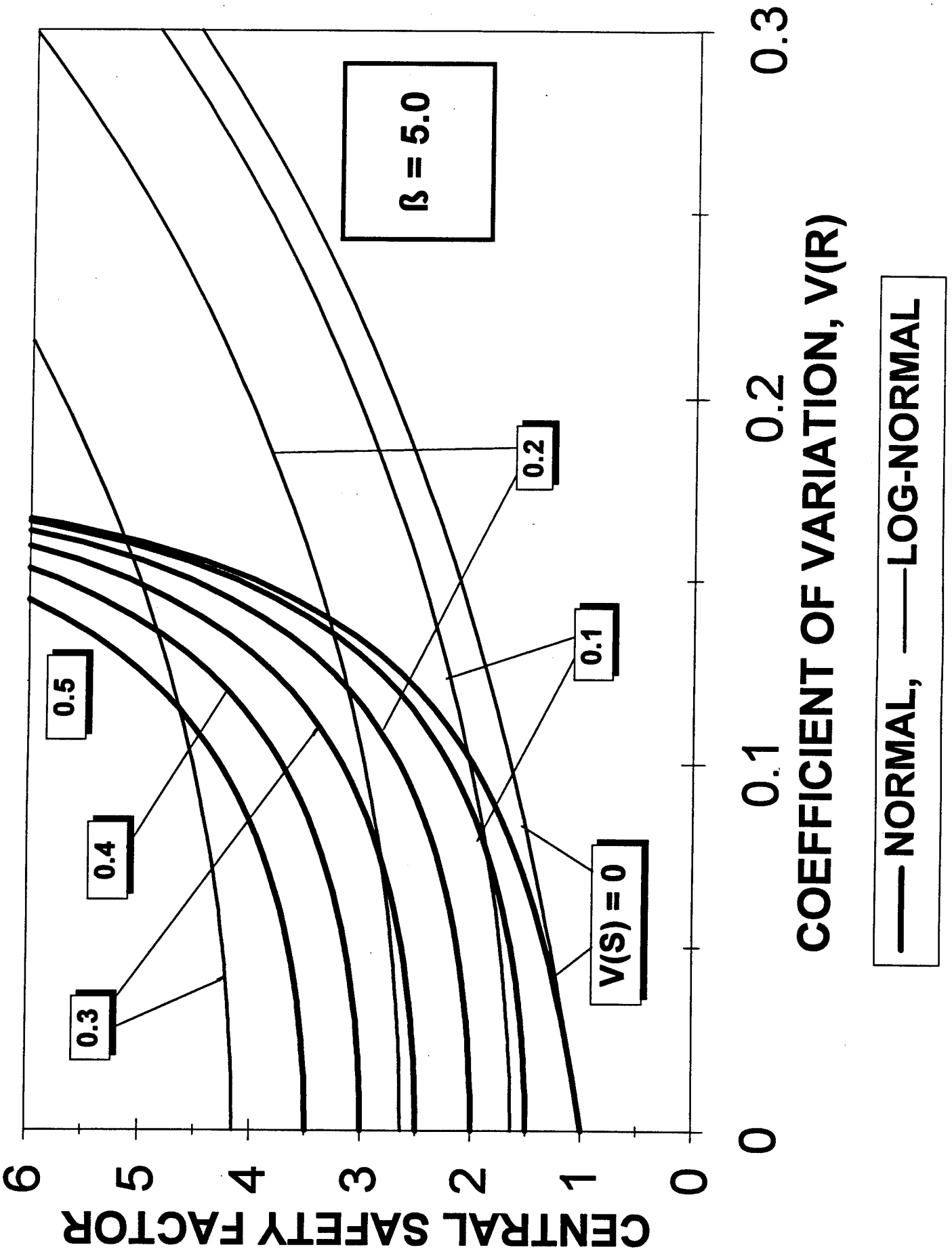

Appendix A A4

Reliability Interaction Charts *Evaluate Reliability Indices*

	V(R) vs V(S)
Function	V(R)
<i>Selected Variable</i>	θ_0
<i>Discrete Variable</i>	β
<i>Continuous Variable</i>	V(S)

Cases

Normal Variates A4.1-1 → A4.1-8

Log-Normal Variates A4.2-1 → A4.2-8

Comparison of Variates. A4.3-1 → A4.3-8

Function	$0 \leq V(R) \leq 0.3$	all charts
<i>Variables</i> Select each θ_0 Display all β , V(S)	θ_0 : 1.1, 1.5, 2, 3, 4, 5, 6 β : 2, 2.5, 3, 3.5, 4, 4.5, 5 $0 \leq V(S) \leq 0.5$	both cases

$$\text{Normal. } V(R) = \sqrt{\frac{\theta_0^2 - 2\theta_0^2 - \beta^2 V_S^2 + 1}{\beta^2 \theta_0^2}}$$

$$\text{Log-Normal. } V(R) = \sqrt{\frac{(\ln \theta_0)^2 - \beta^2 V_S^2}{\beta^2} \left[\frac{\theta_{\text{actual}}}{\theta_{\text{estimated}}} \right]}$$

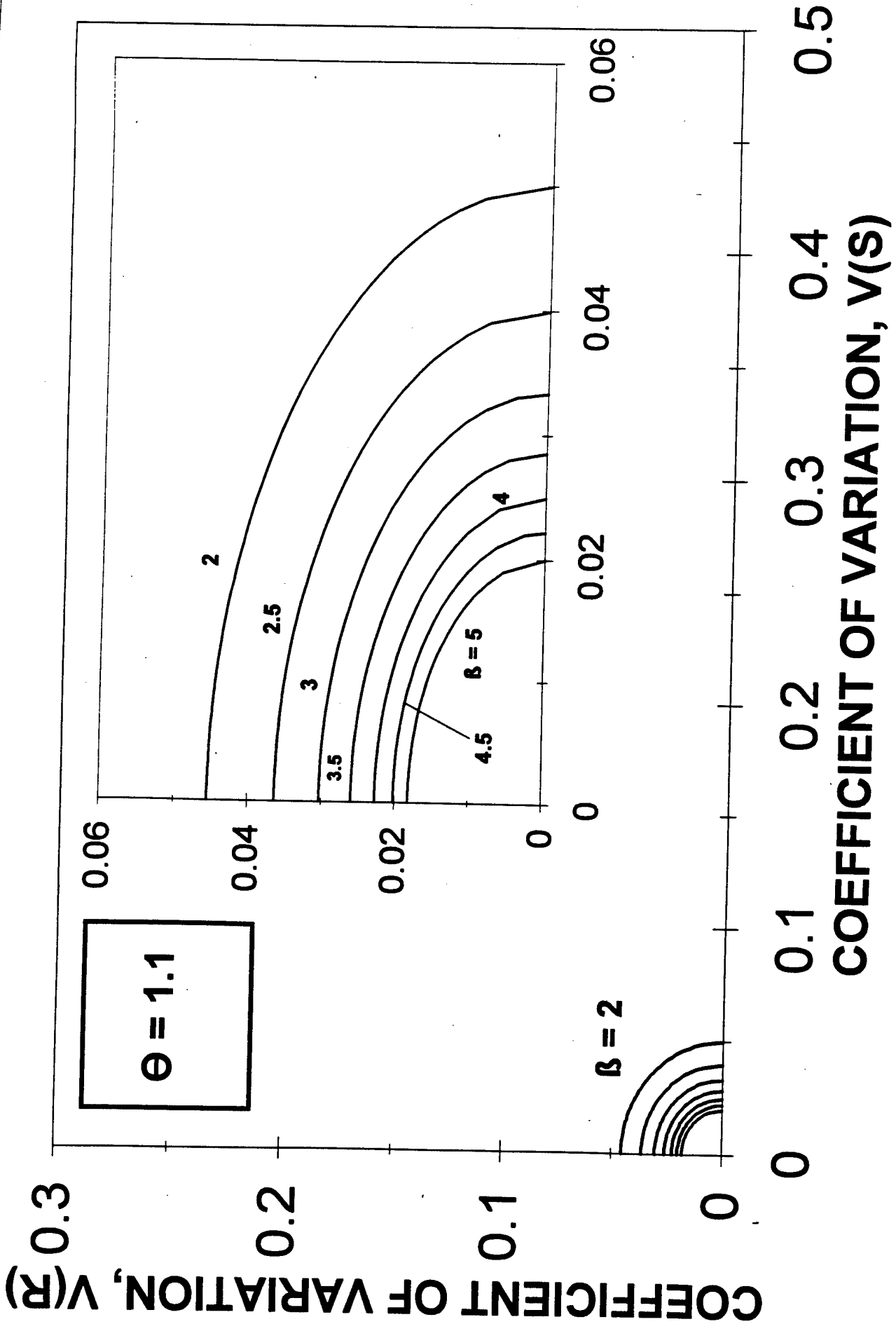

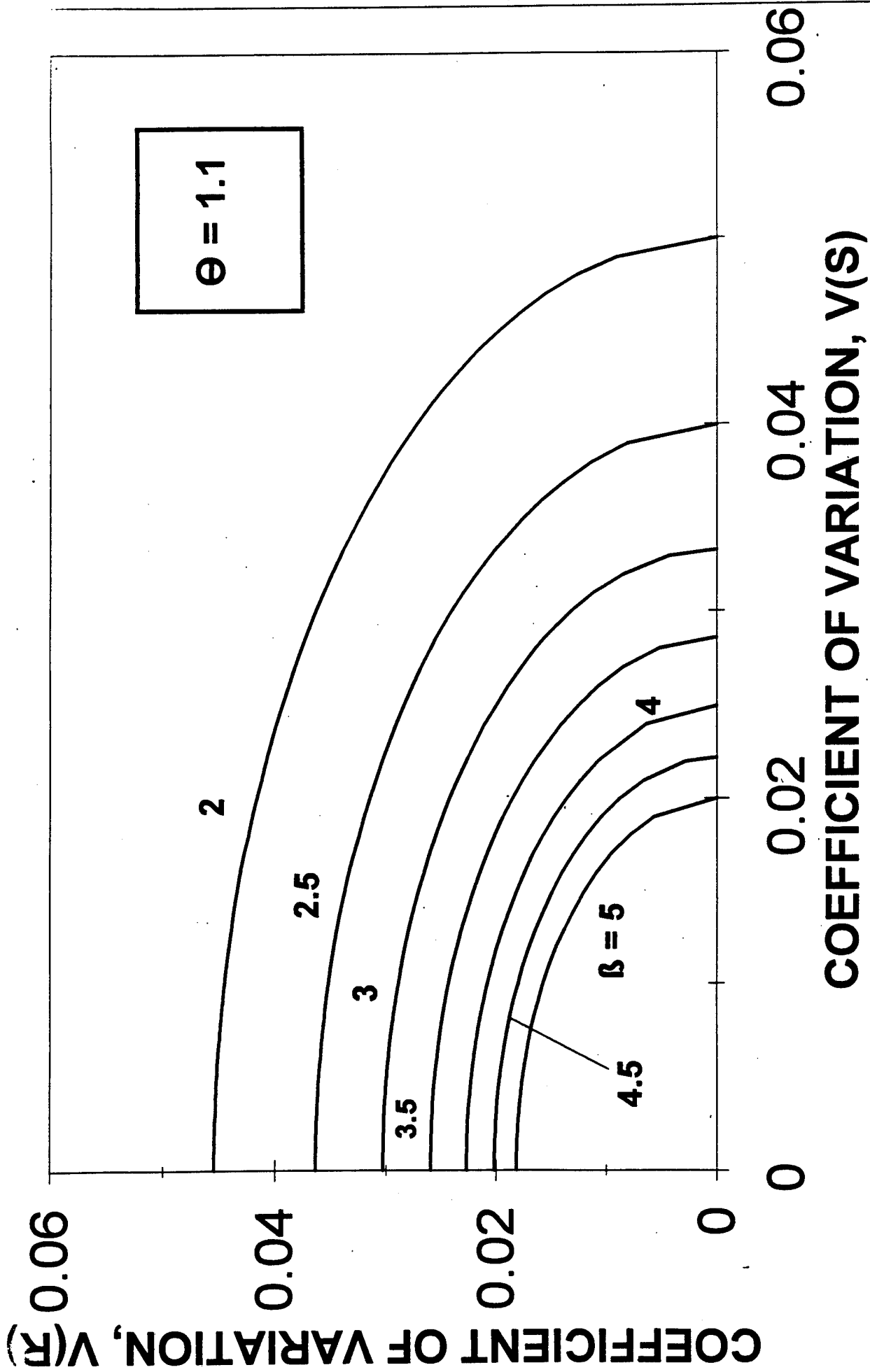

R: NORMAL, S: NORMAL

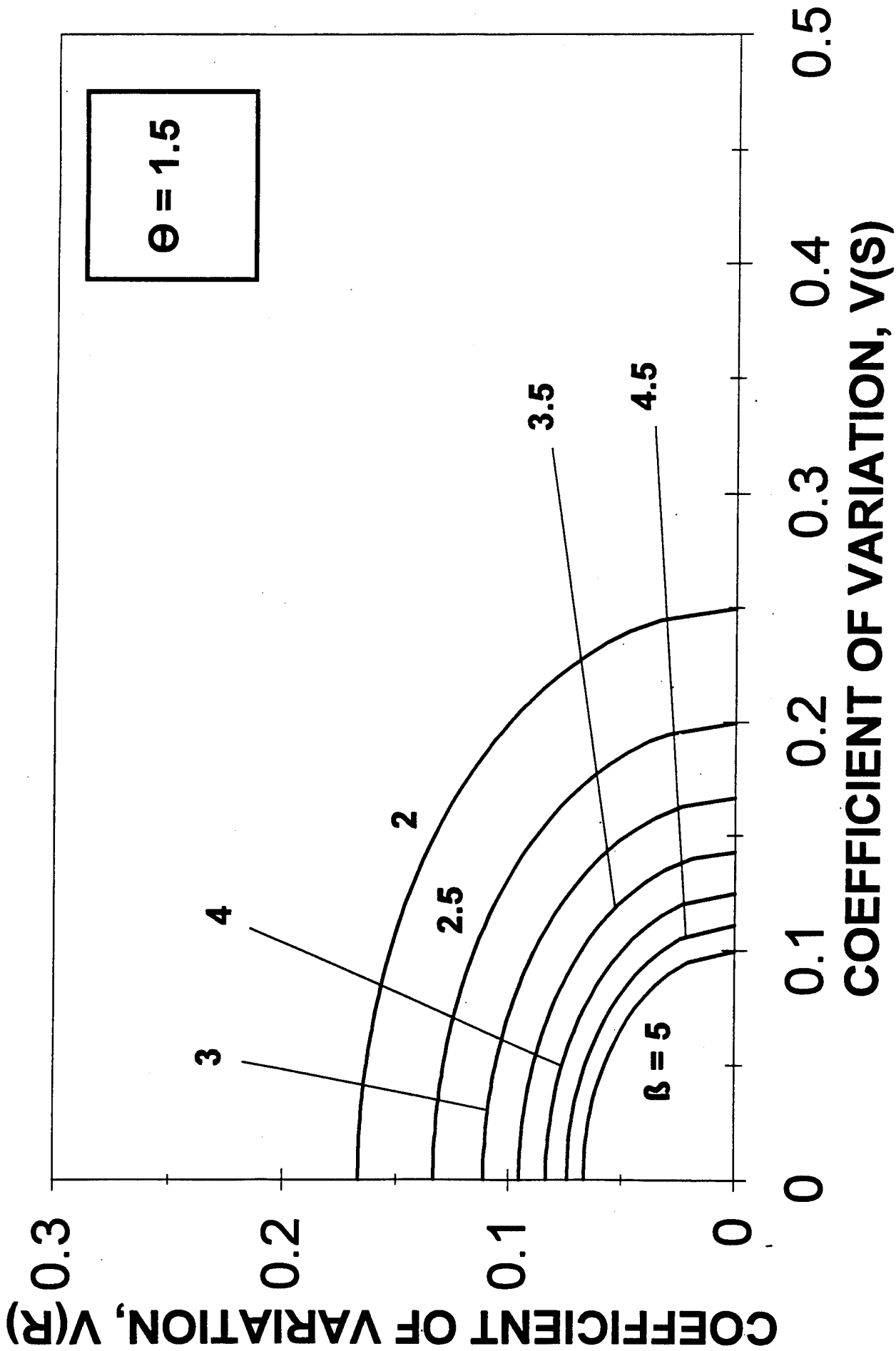

R: NORMAL, S: NORMAL

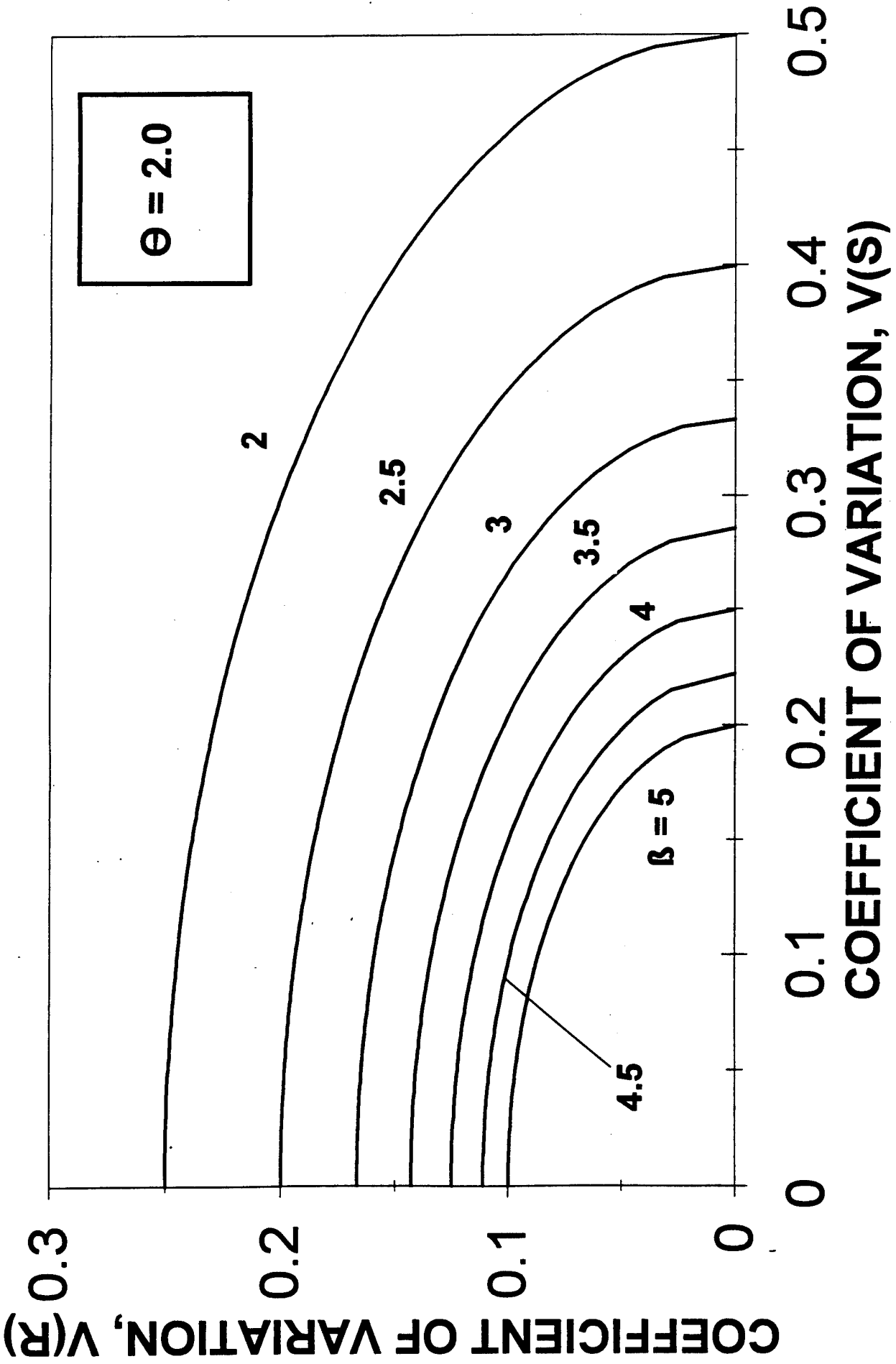

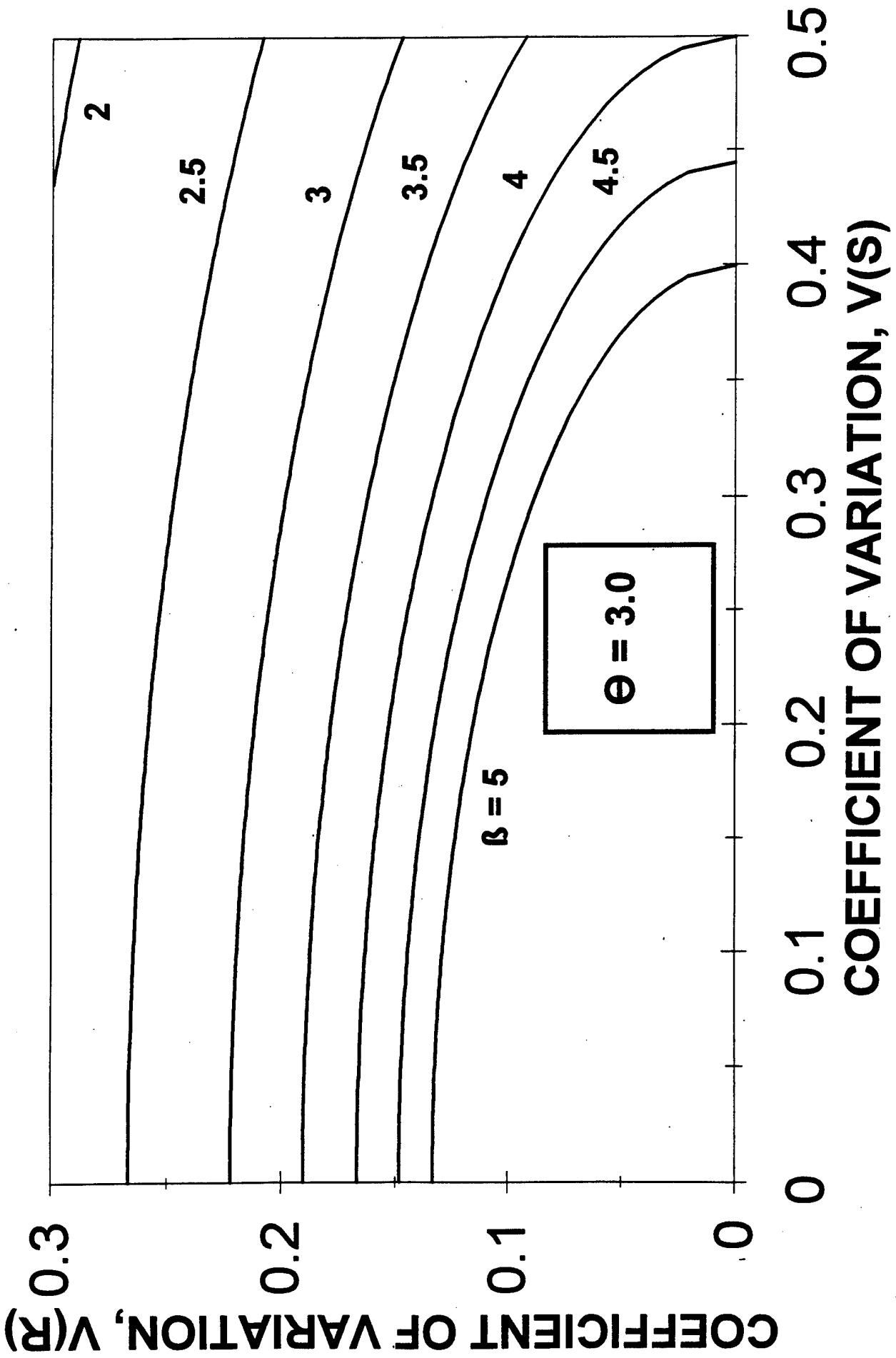

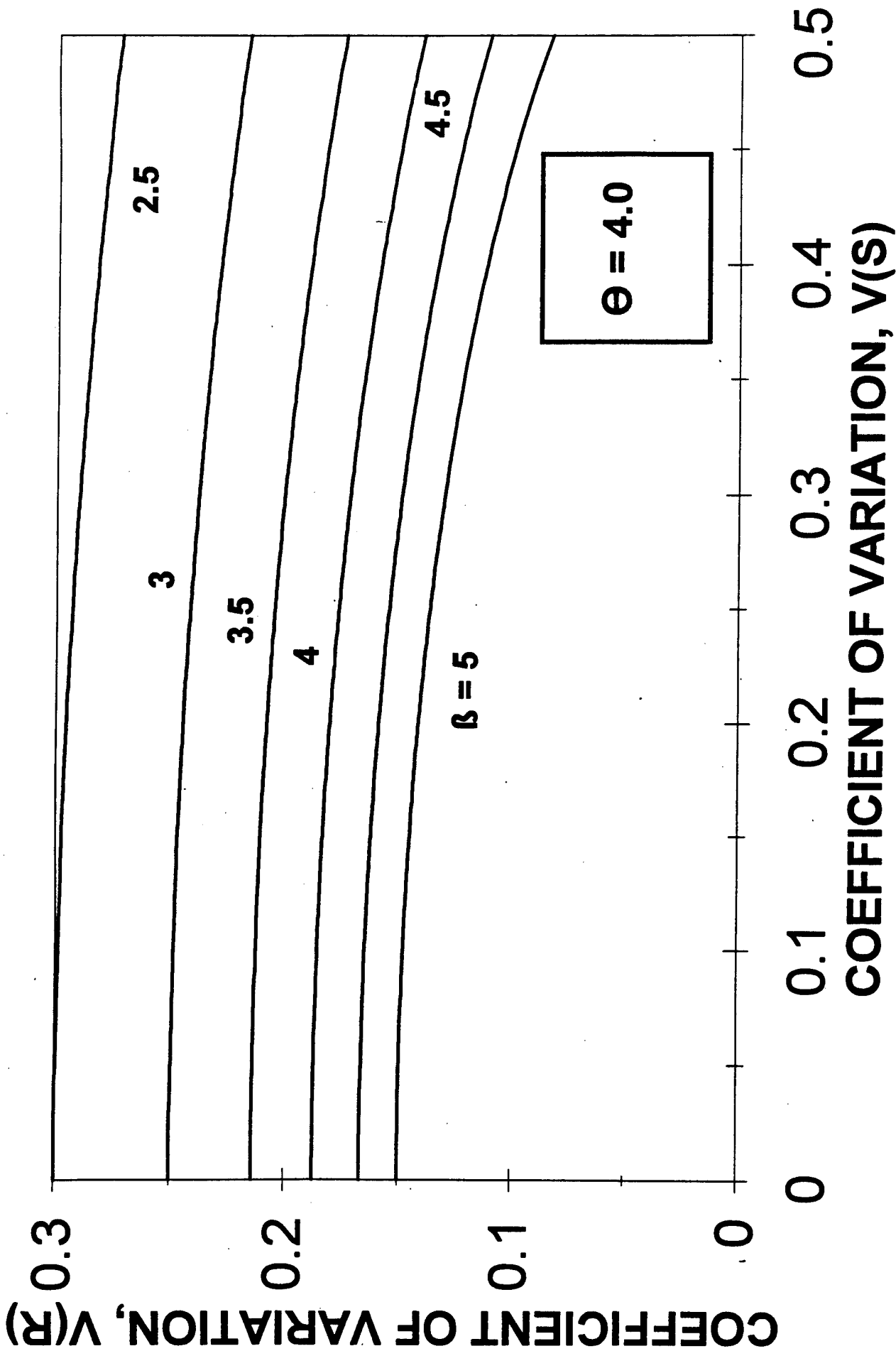

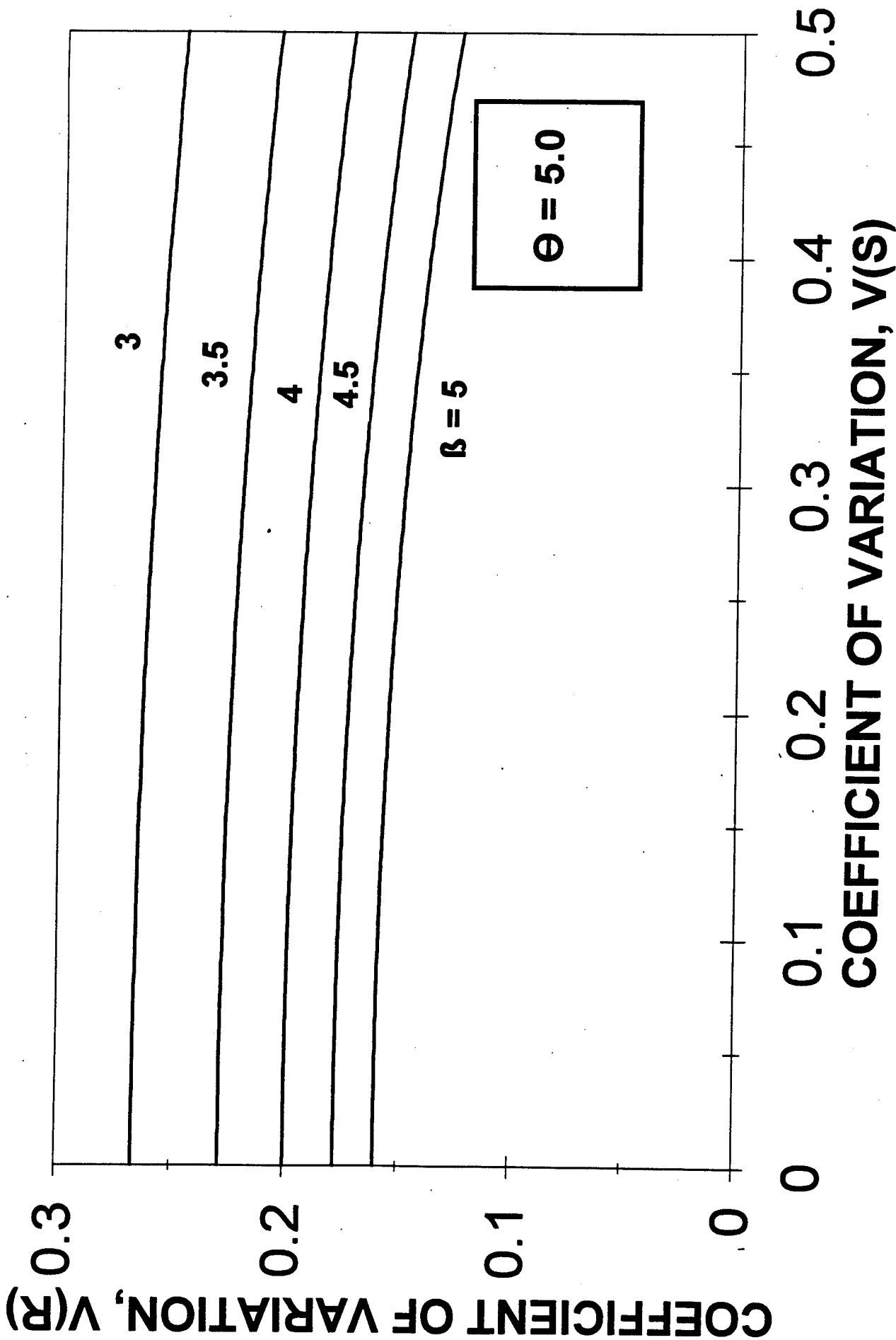

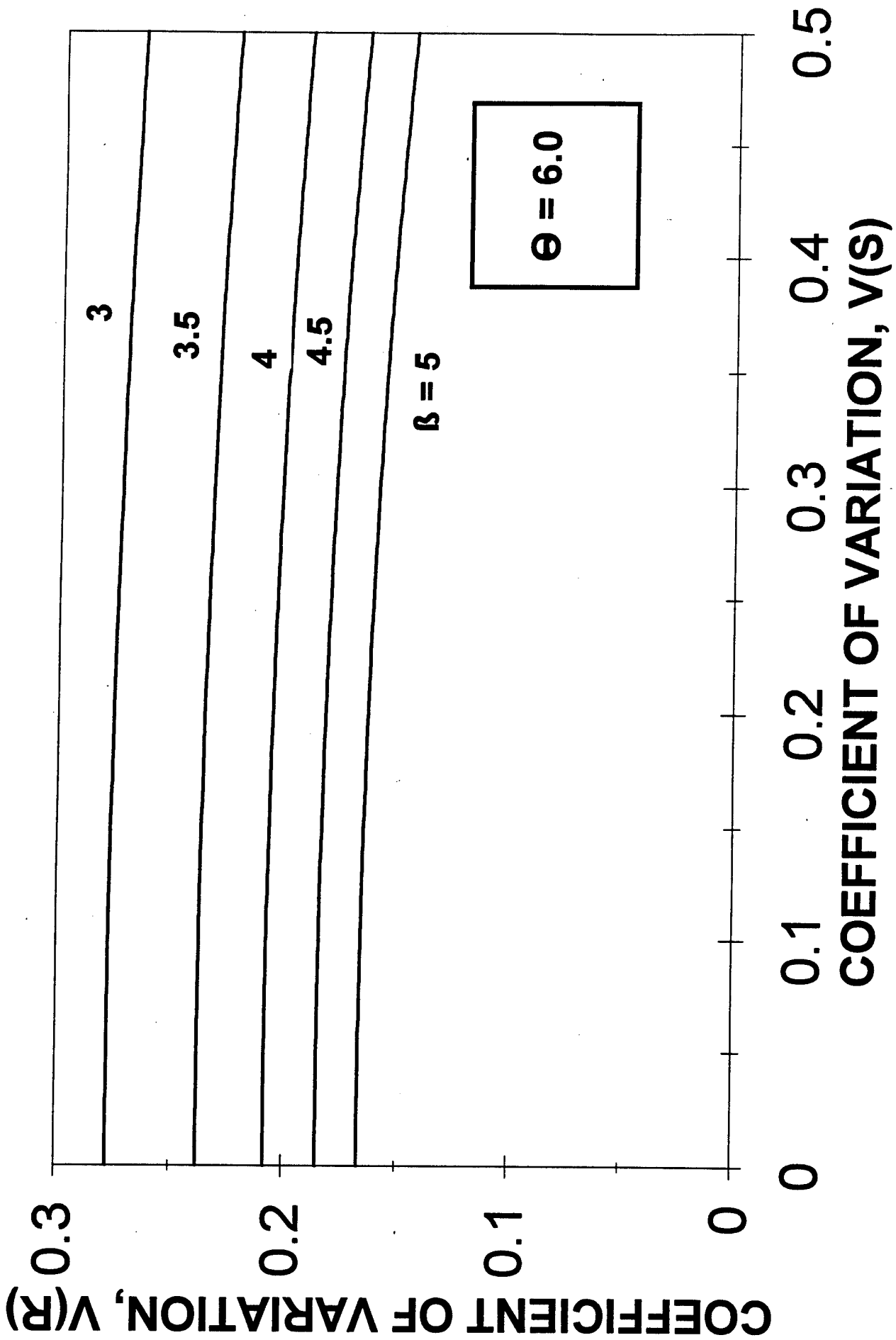

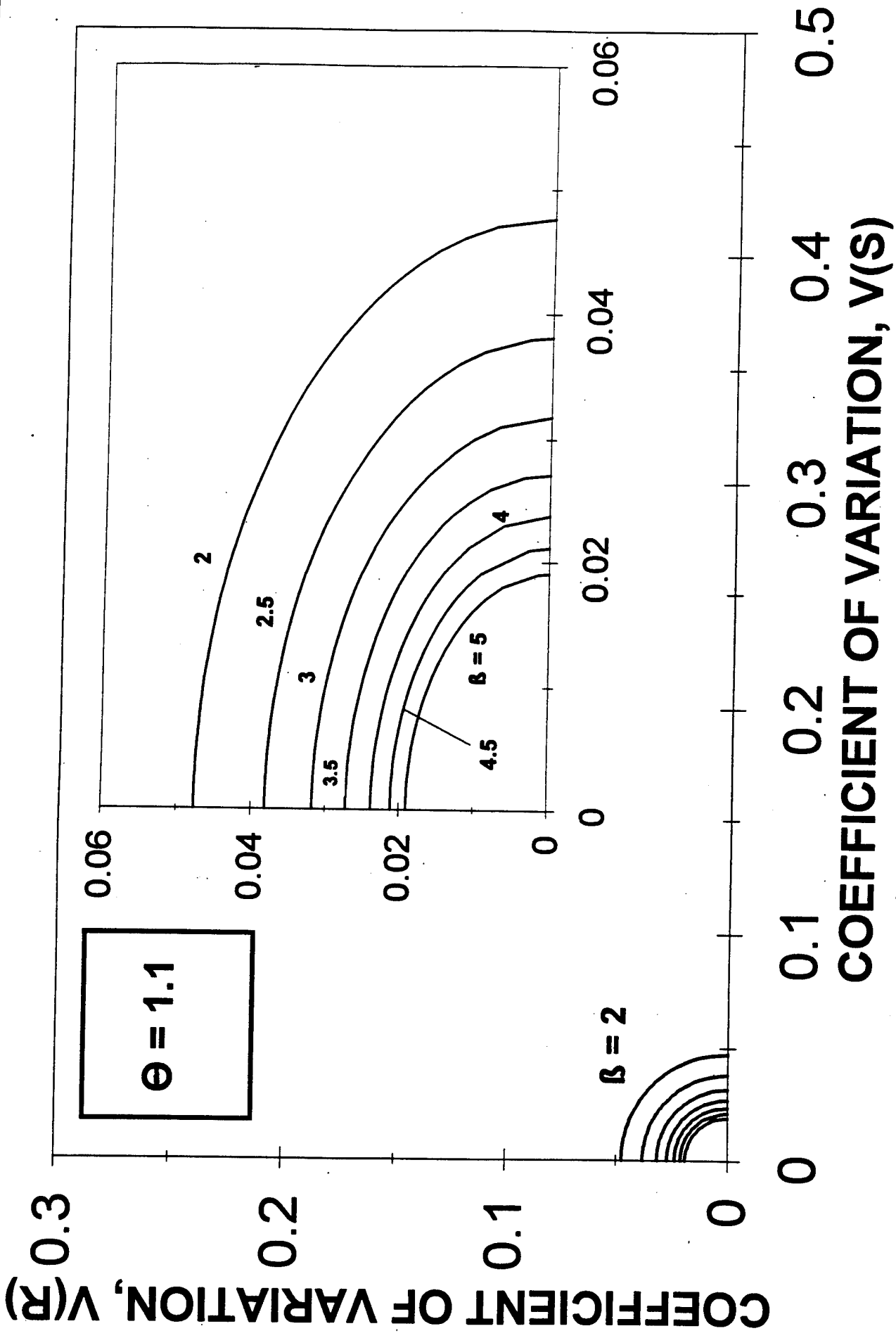

R: LOG-NORMAL, S: LOG-NORMAL

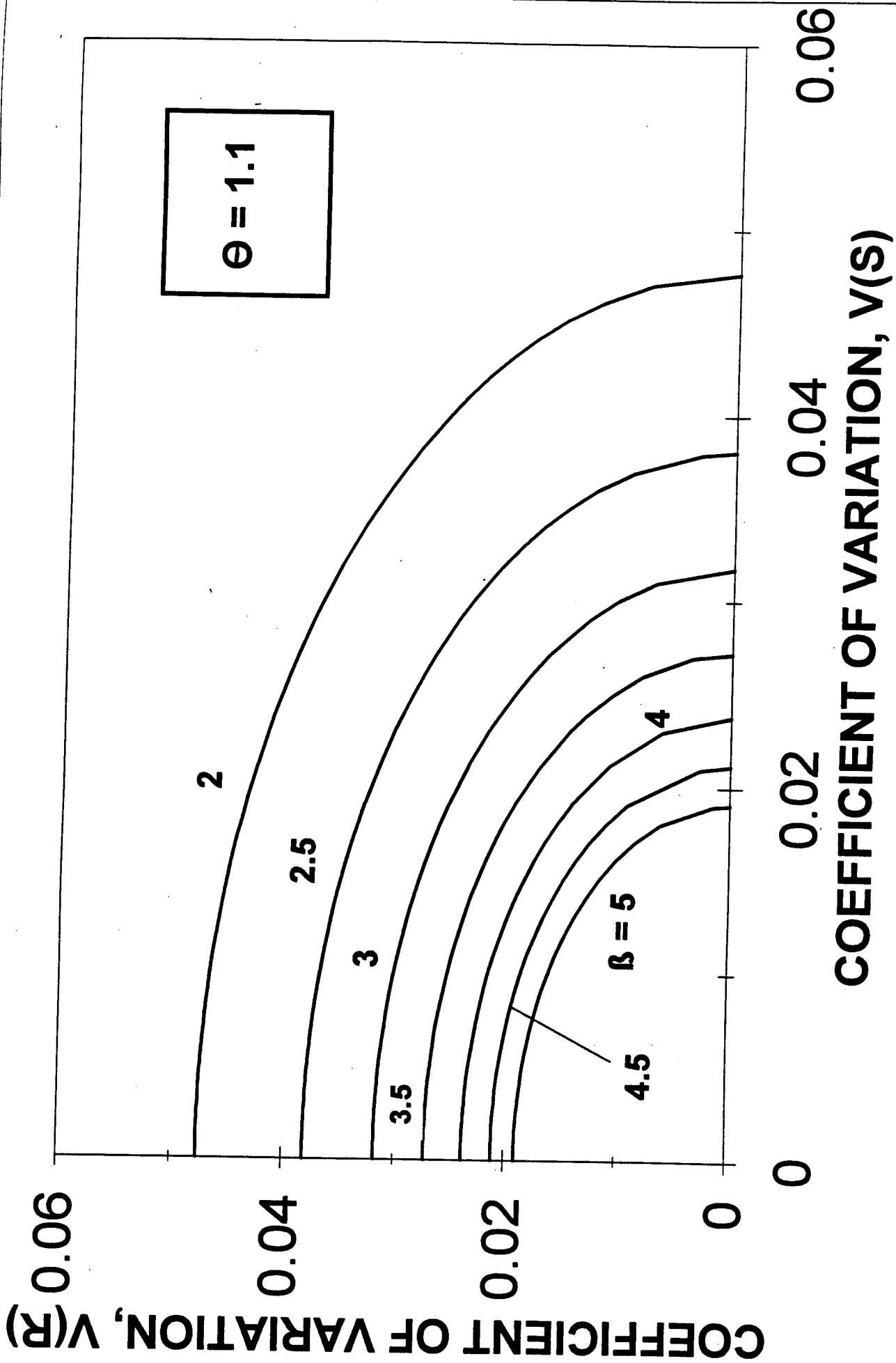

R: LOG-NORMAL, S: LOG-NORMAL

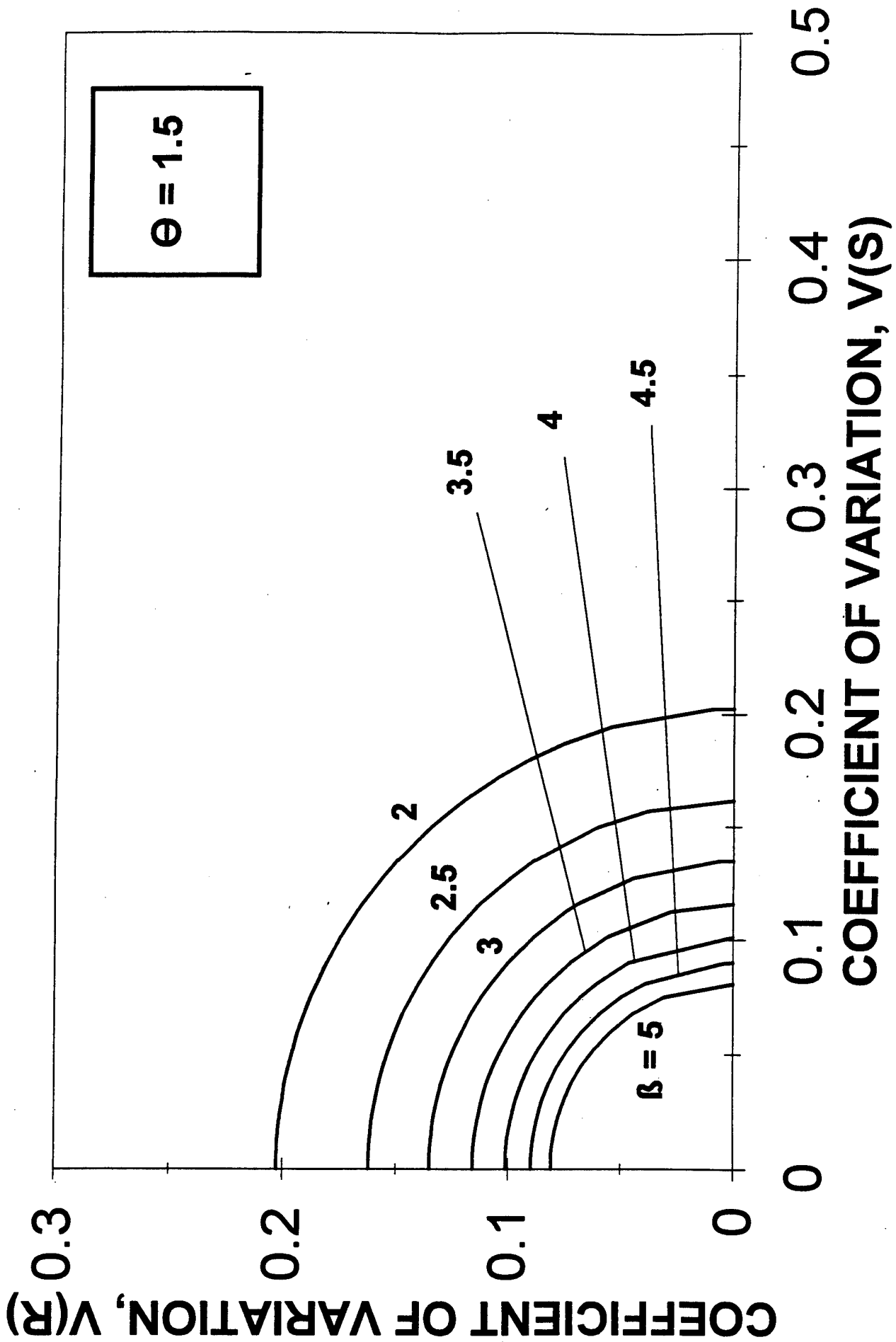

R: LOG-NORMAL, S: LOG-NORMAL

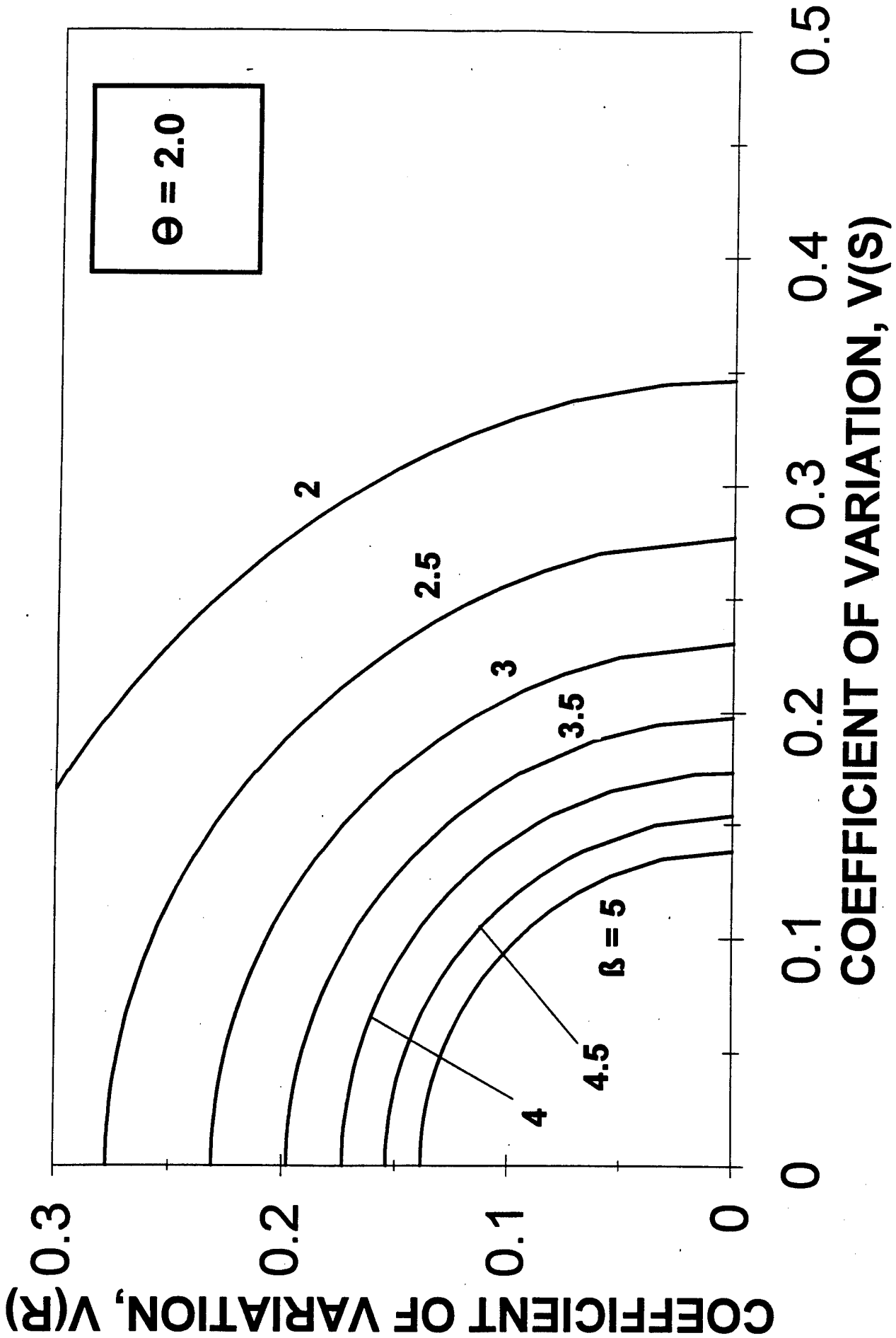

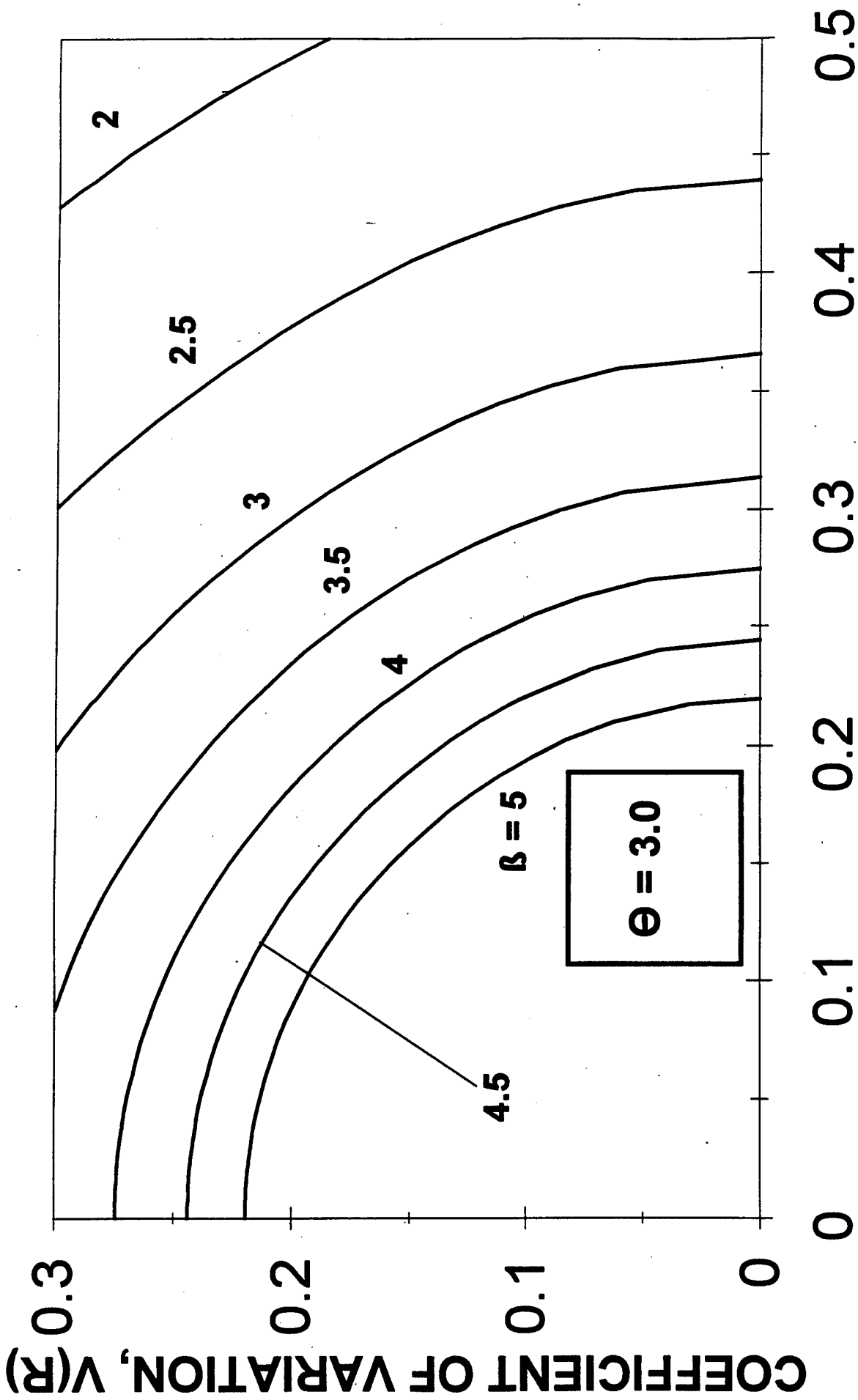

R: LOG-NORMAL, S: LOG-NORMAL

$\theta = 3.0$

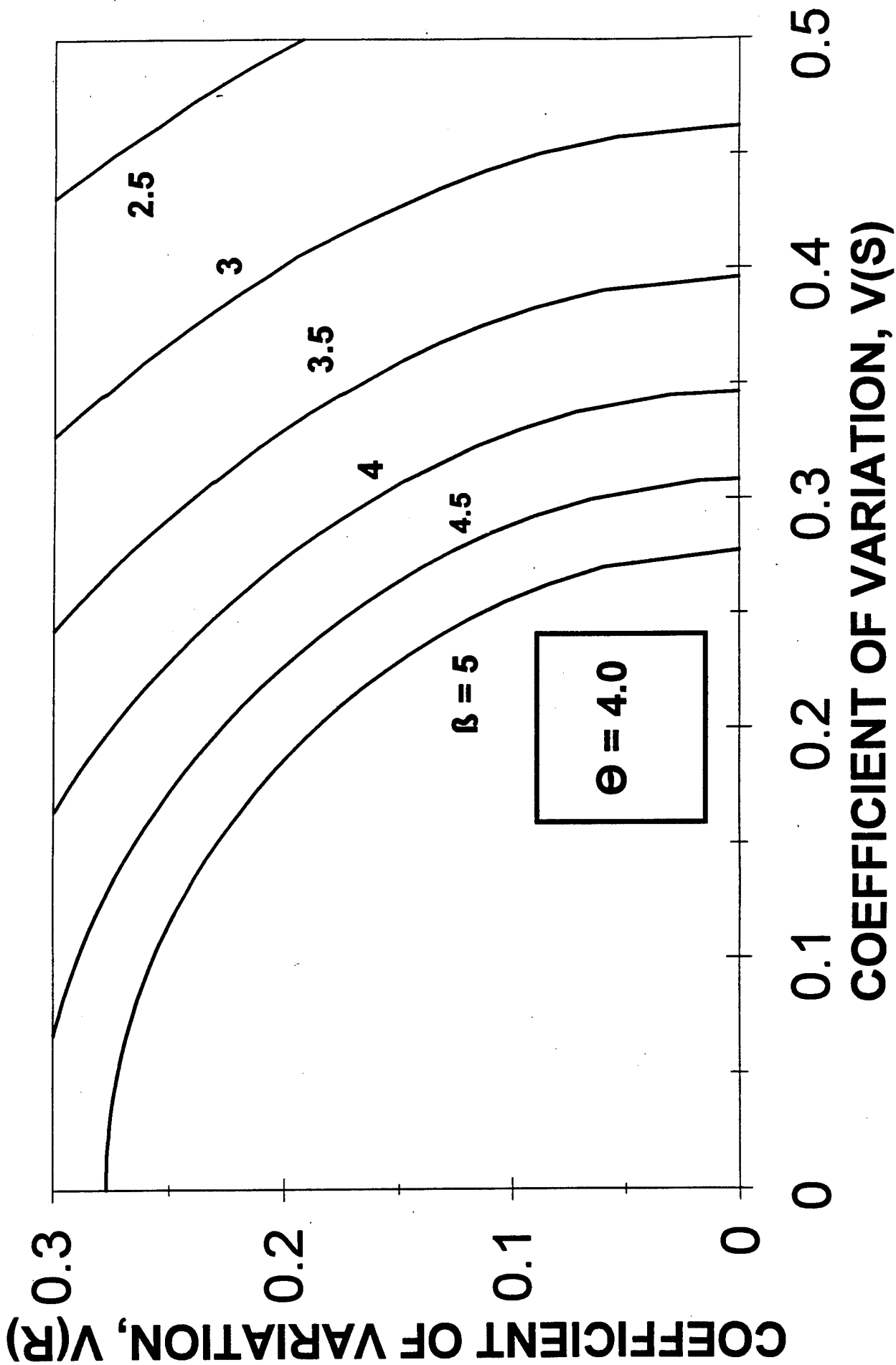

R: LOG-NORMAL, S: LOG-NORMAL

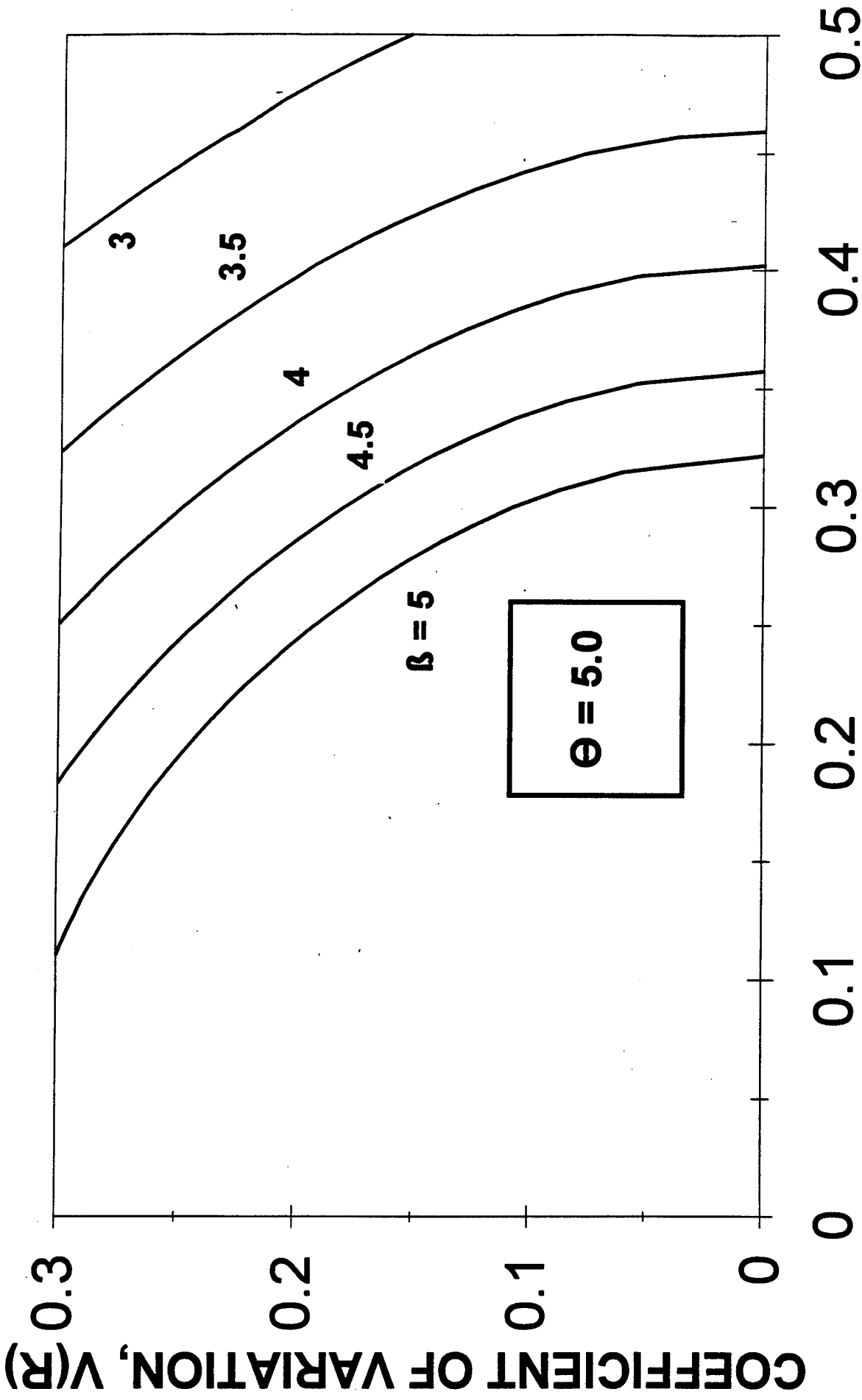

COEFFICIENT OF VARIATION, V(S)

R: LOG-NORMAL, S: LOG-NORMAL

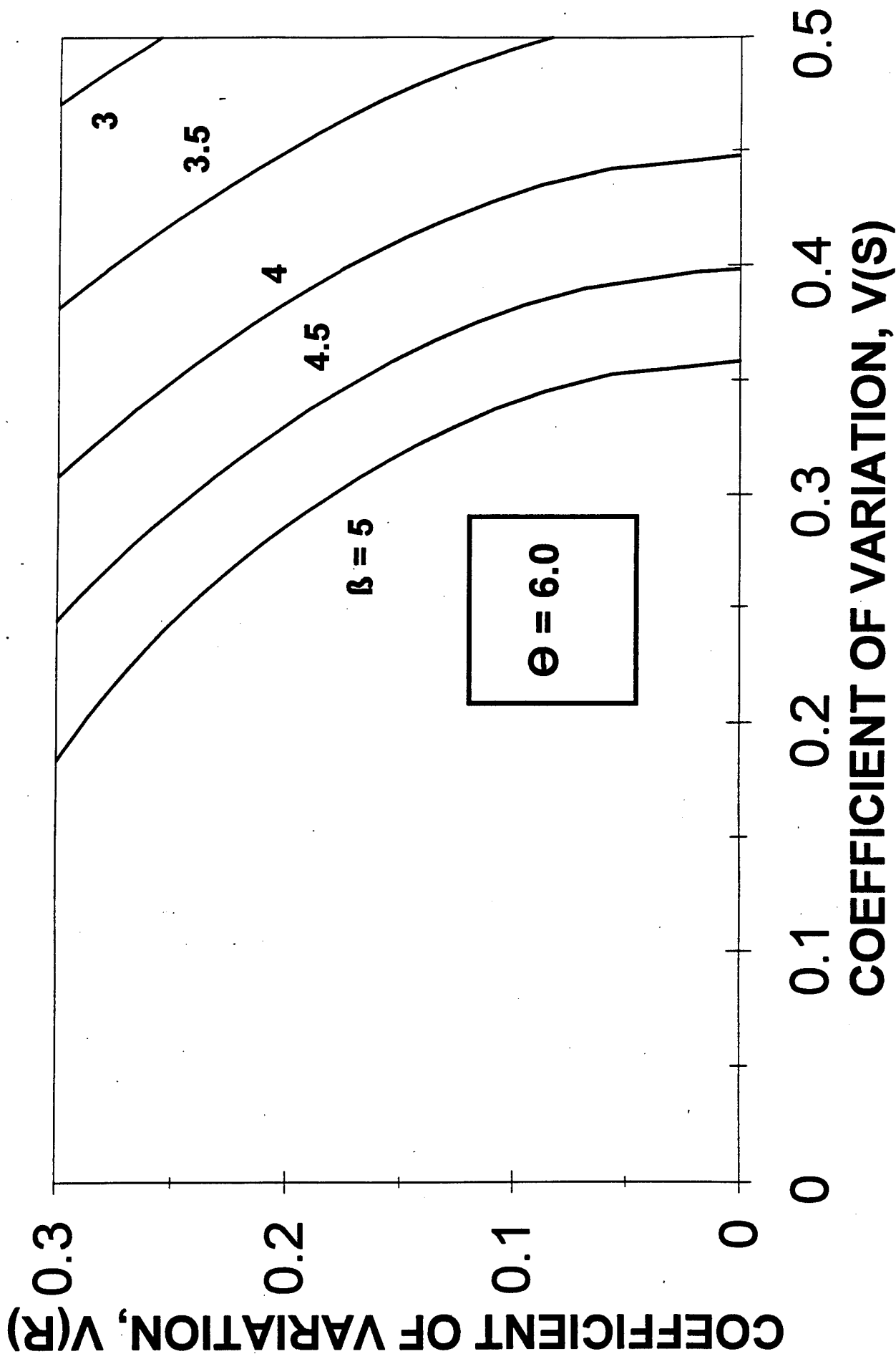

R: LOG-NORMAL, S: LOG-NORMAL

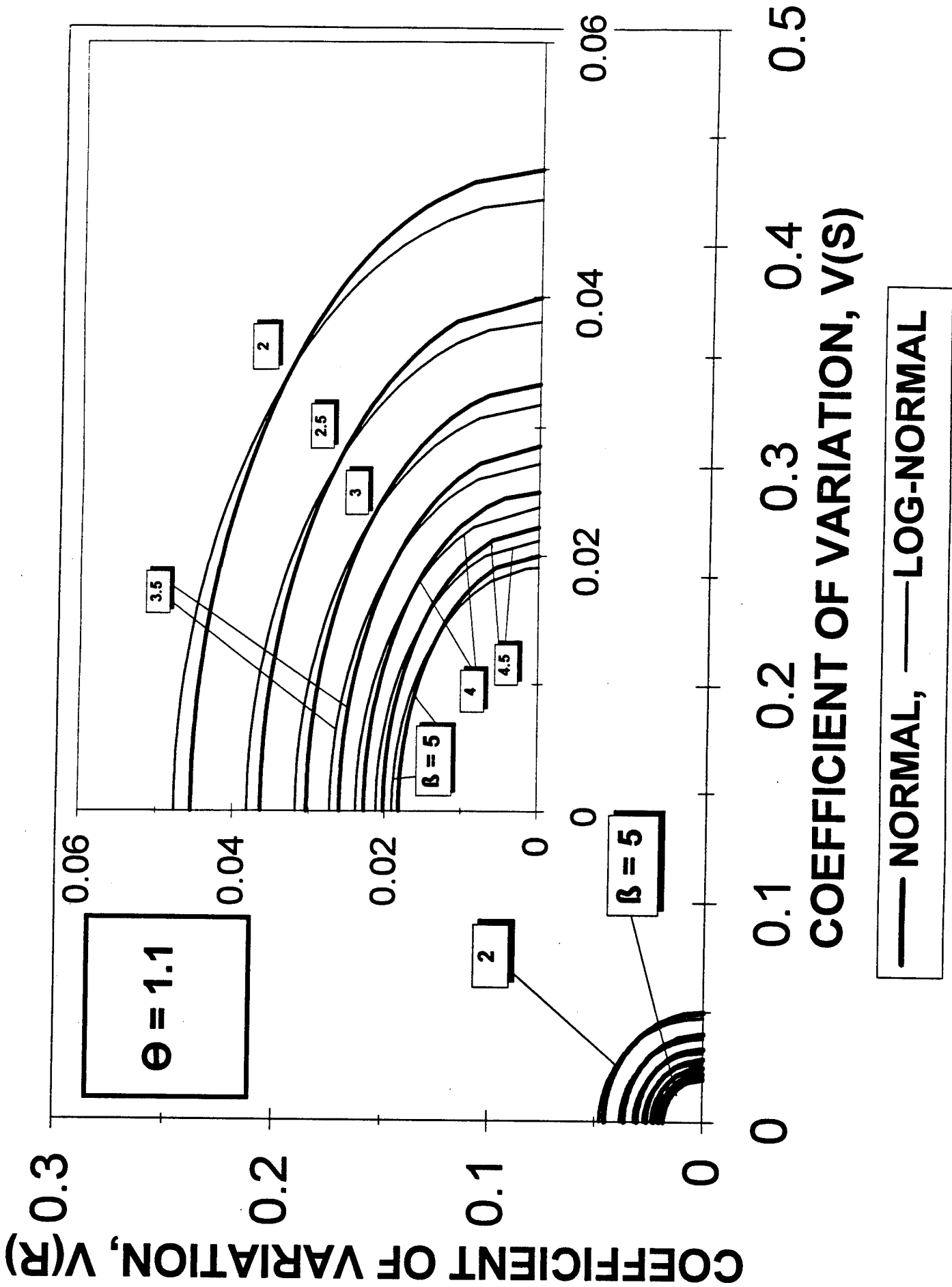

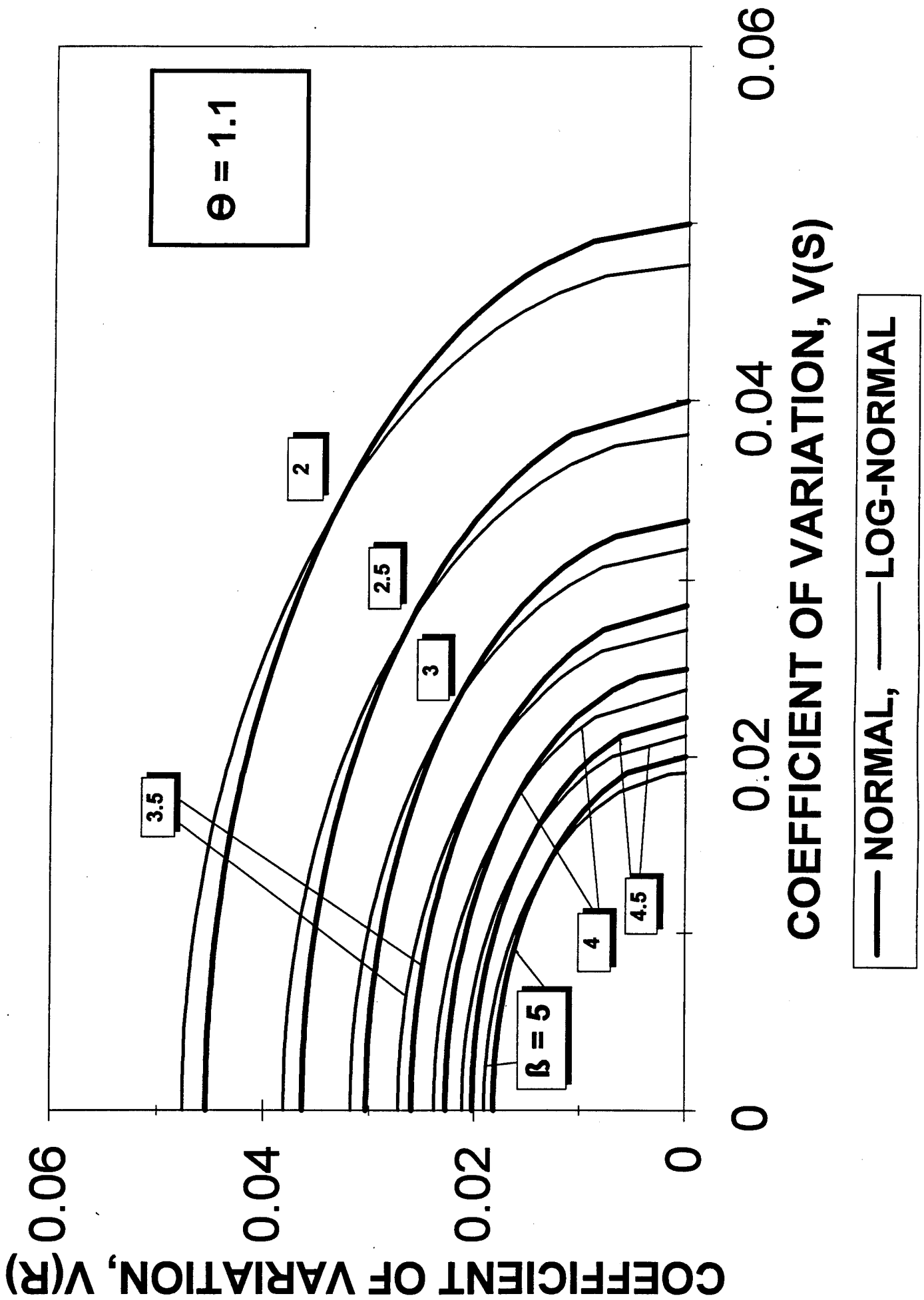

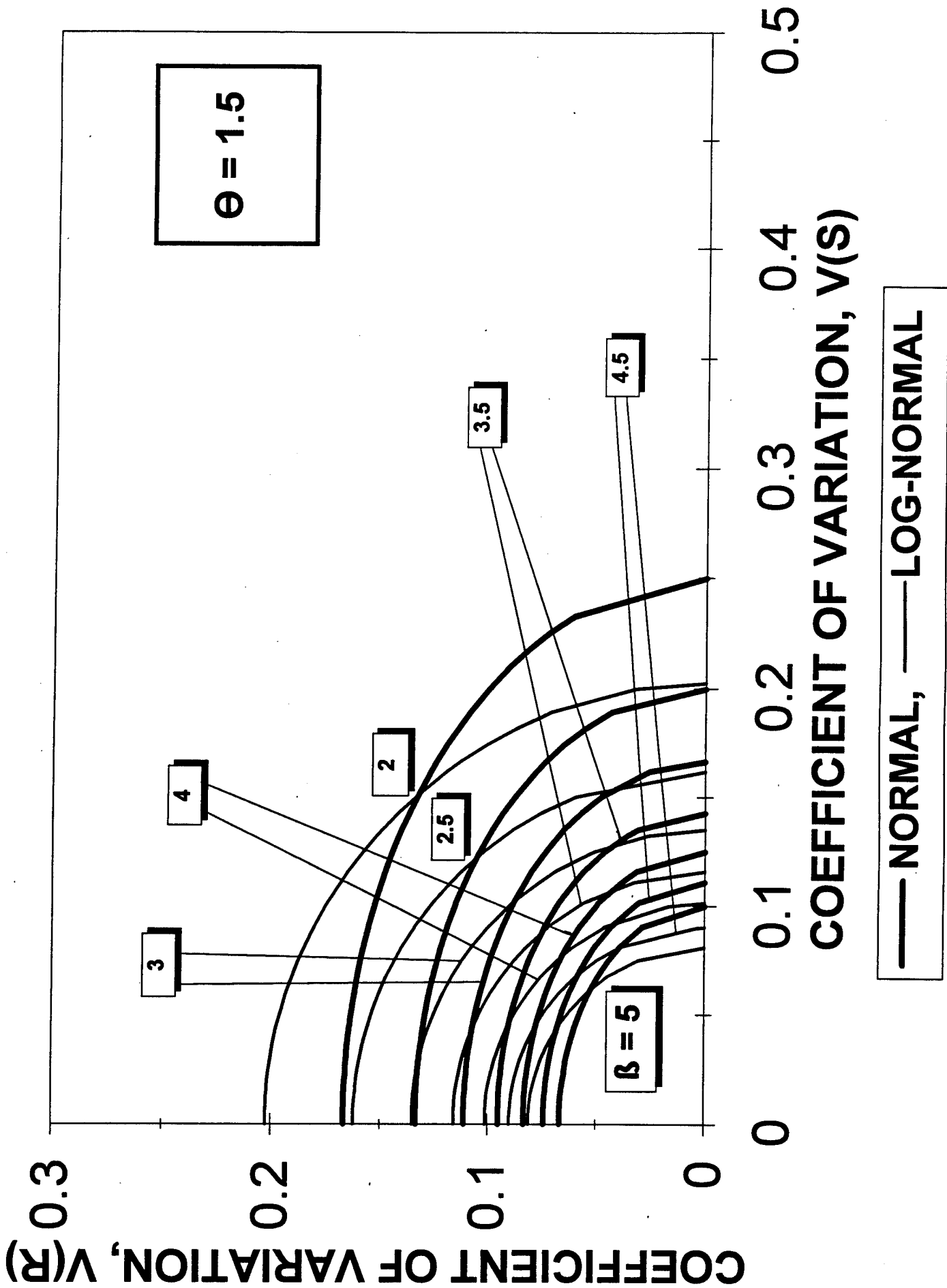

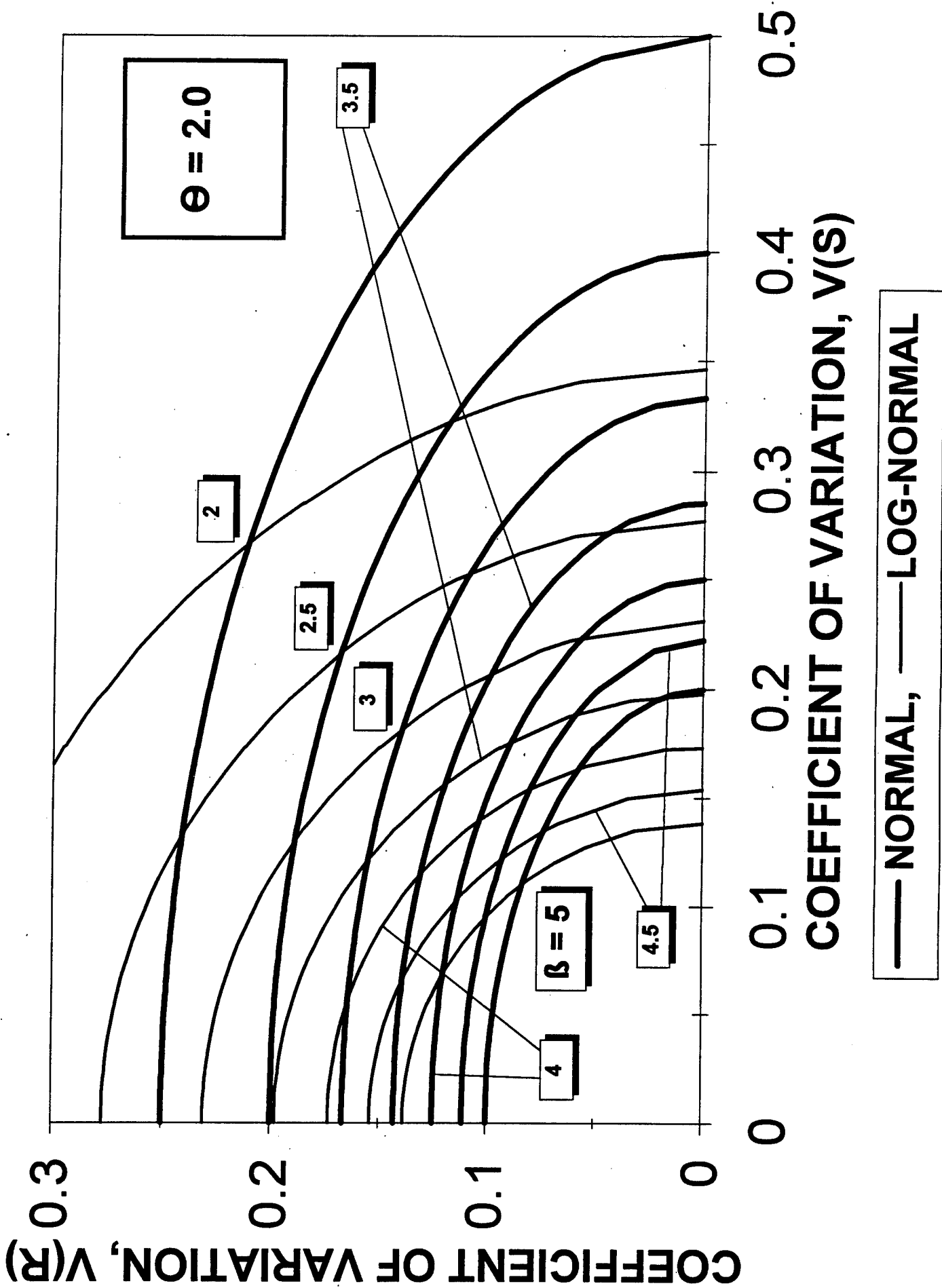

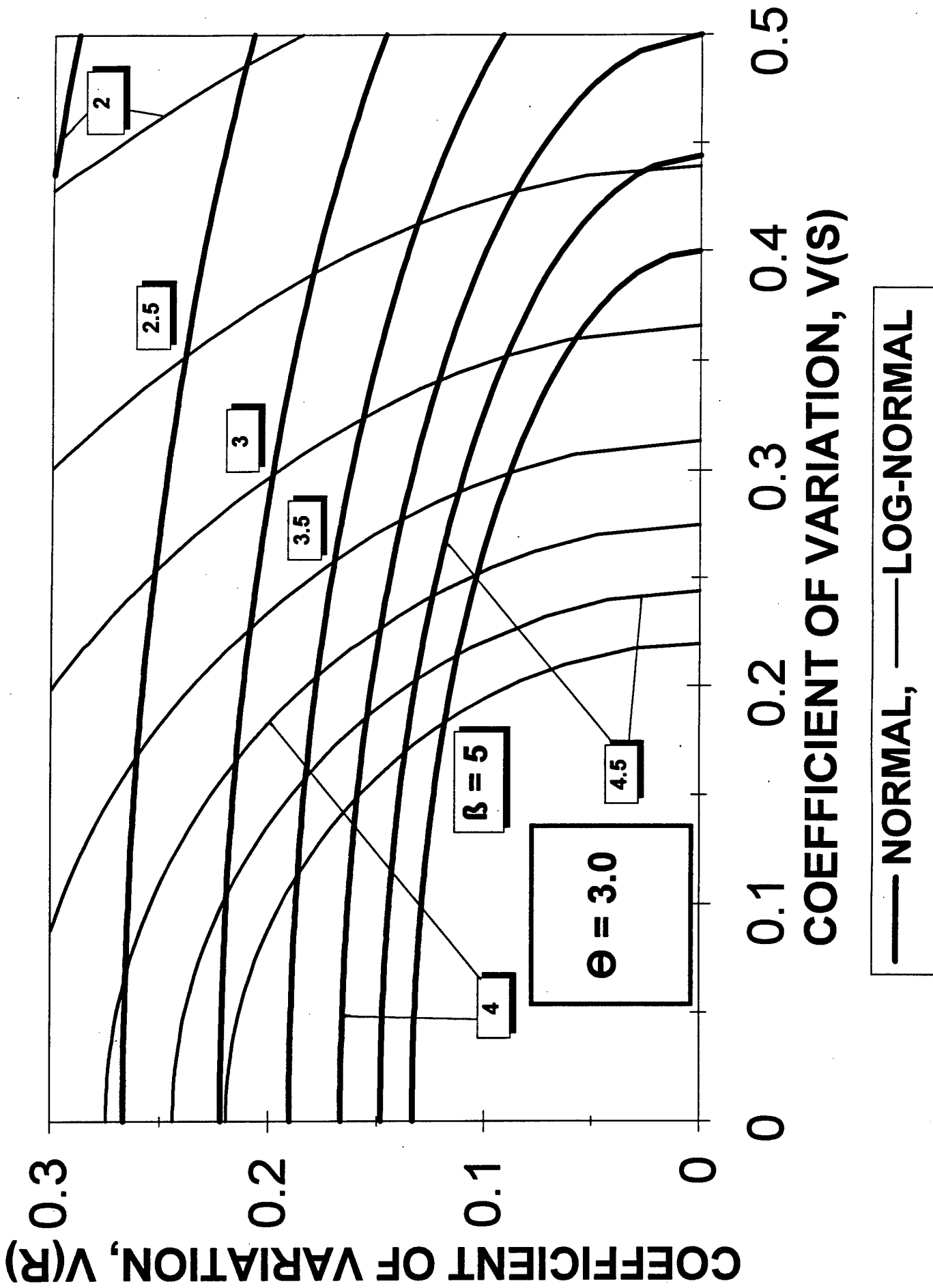

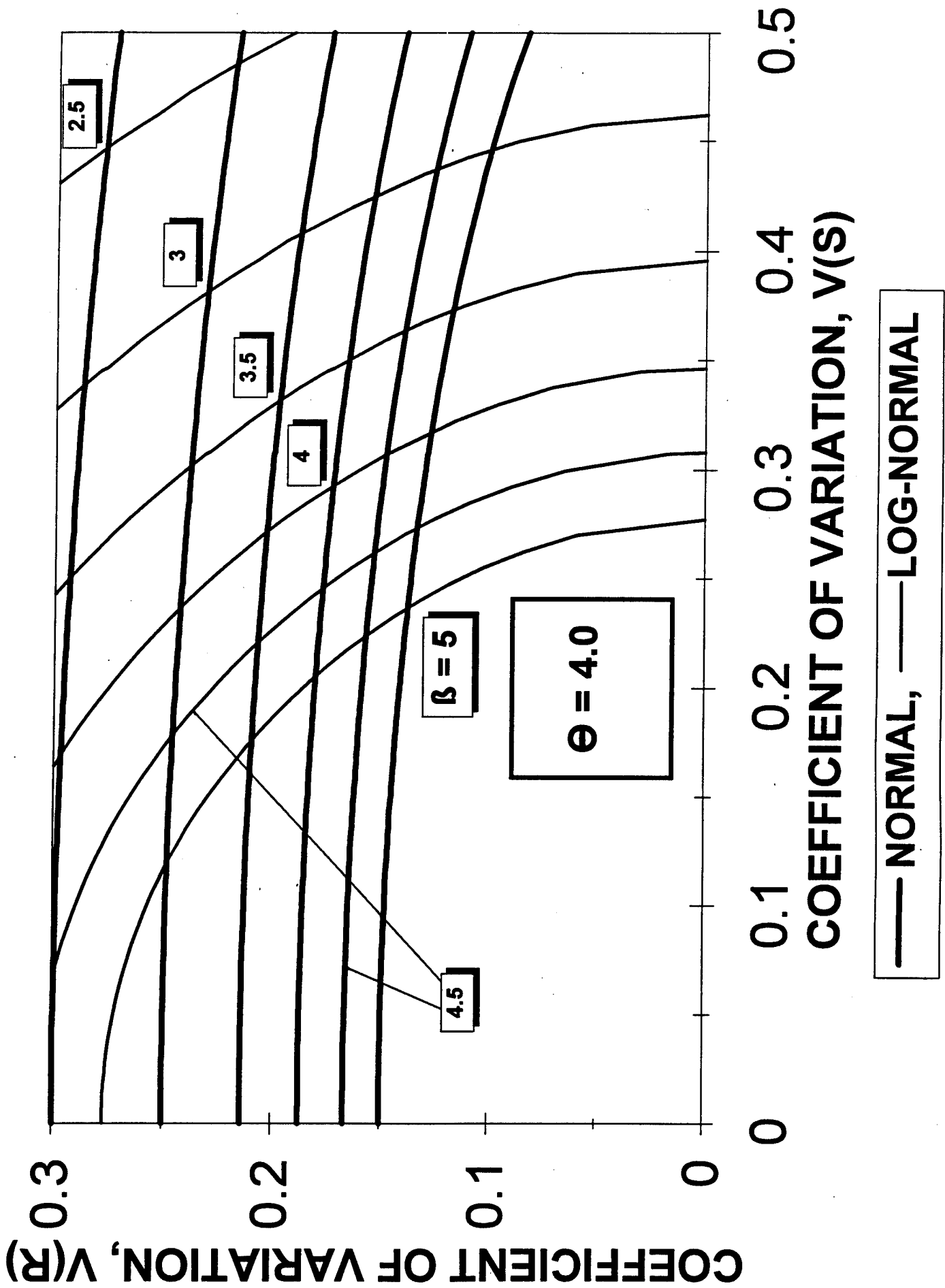

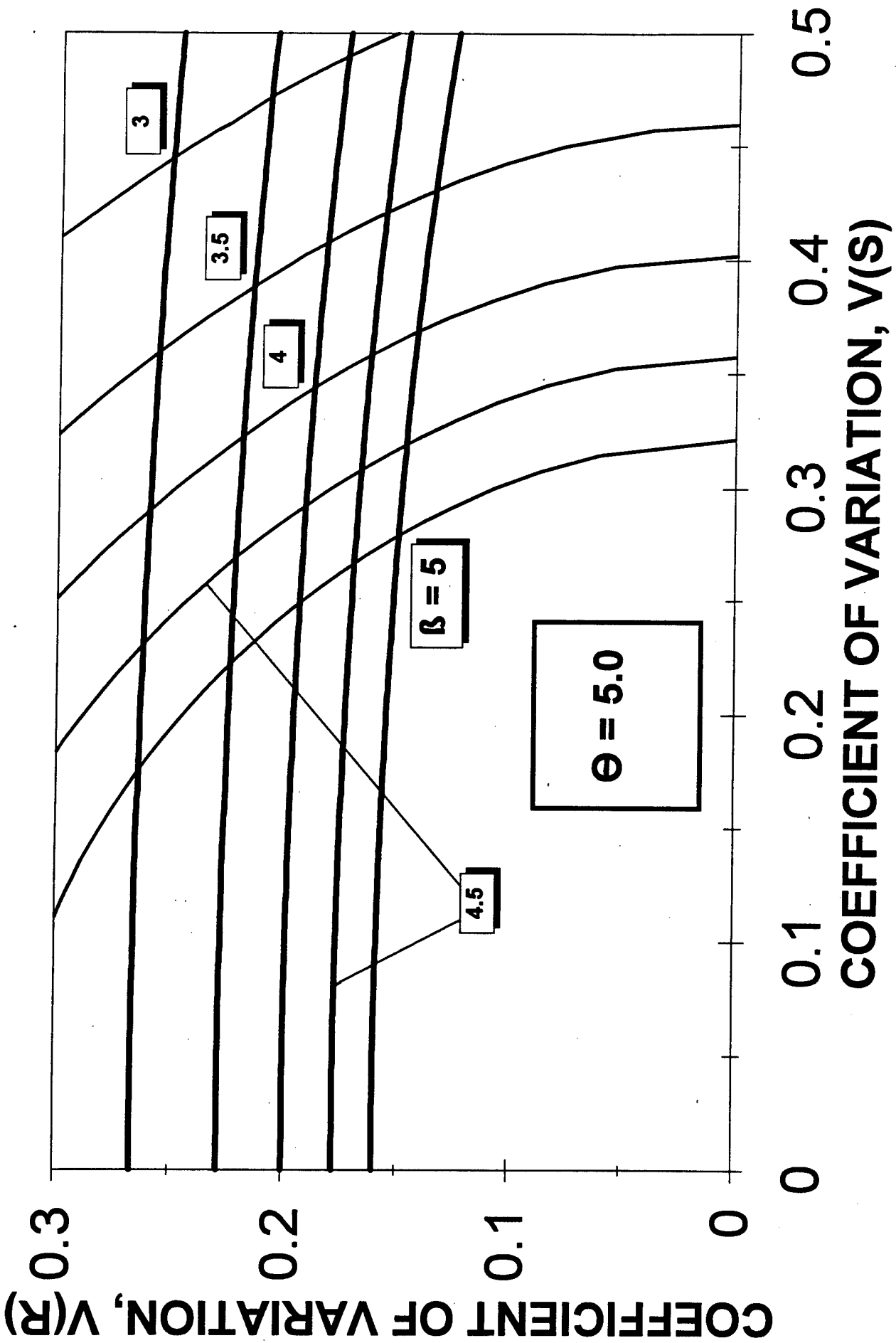

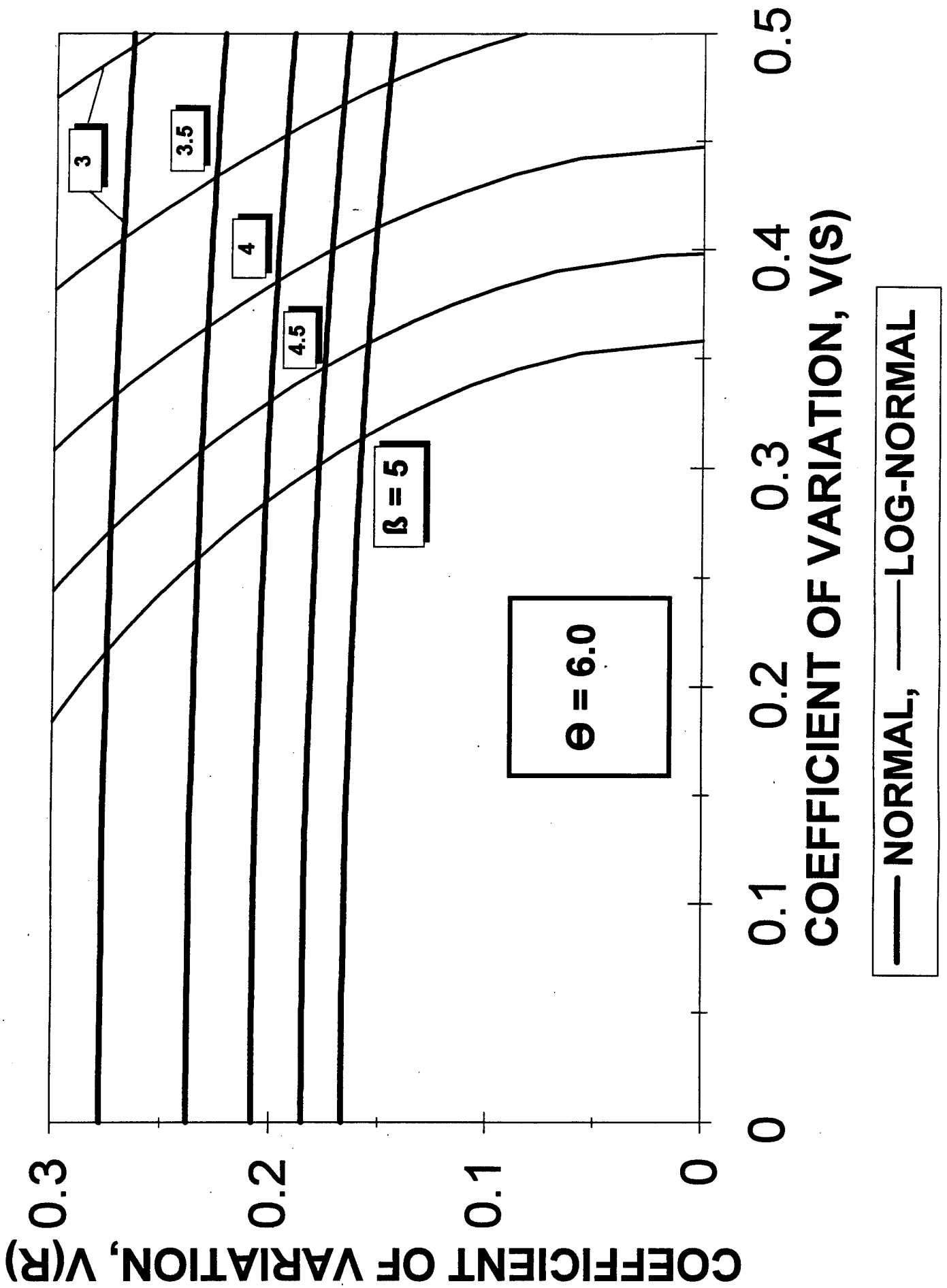

Reliability Index versus Safety Factor of Structures

Appendix B

Sample Sets

B1	<i>CVEN 5555</i> notes
B2	<i>Laursen</i> , p. 46, #2-8
B3	<i>Laursen</i> , p. 46, #2-7
B4	<i>Laursen</i> , p. 46, #2-9
B5	<i>AISC</i> , p. 2-306, #29
B6	<i>AISC</i> , p. 2-308, #35

Components

Bx.1-1	Reliability Analysis Step problem statement and minimum β results
Bx.1-2	Design Step problem statement and minimum β results
Bx.2-x	Piecewise Equations
Bx.3-x	Structural Analysis of Loads
Bx.4-x	Reliability Analysis Step Reliability and Safety Factor Diagrams
Bx.5-x	Design Step Reliability and Safety Factor Diagrams

Reliability Index vs Safety Factor in Structures

Appendix B

B1

Sample System 1

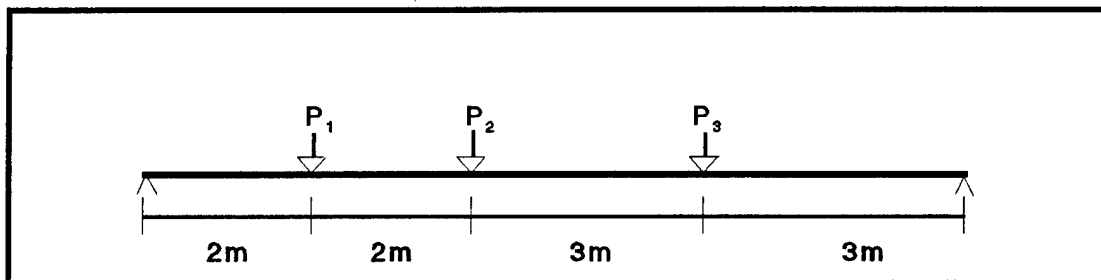

Figure 3.1a Simply Supported Beam (CVEN 5555)

Contents

- 1-1 Reliability Analysis Step problem statement
- 1-2 Design Step problem statement and minimum β results
- 2 Piecewise equations
- 3 Structural Analysis of Loads Diagrams
- 4 *N/A--method set up only*
- 5 Design Step Reliability and Safety Factor Diagrams

SAMPLE SYSTEM 1

Simply Supported Beam

Three random concentrated loads

Assume normal, then log-normal, distribution for load and resistance

Uniform beam

Problem (Calibration)

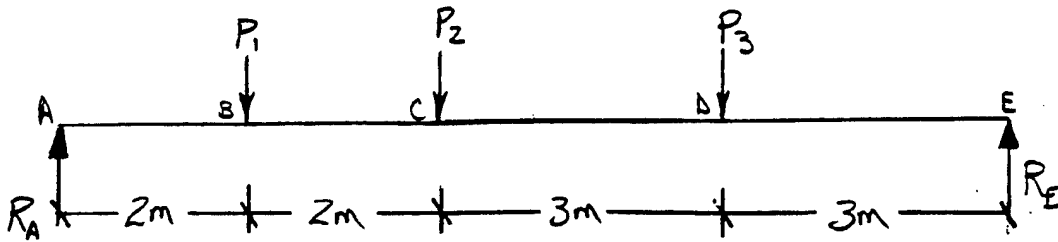

Loading

	Mean (kN)	C.O.V.
P1	3	8%
P2	5	12%
P3	8	10%

Load Correlation

Correlation Coefficients	Case <i>i</i>	Case <i>ii</i>
$\rho (P_1, P_2)$	0	1
$\rho (P_1, P_3)$	0	0
$\rho (P_2, P_3)$	0	0

SAMPLE SYSTEM 1

Simply Supported Beam

Three random concentrated loads

Assume normal, then log-normal, distribution for load and resistance

Uniform beam

Problem Find location of minimum reliability.

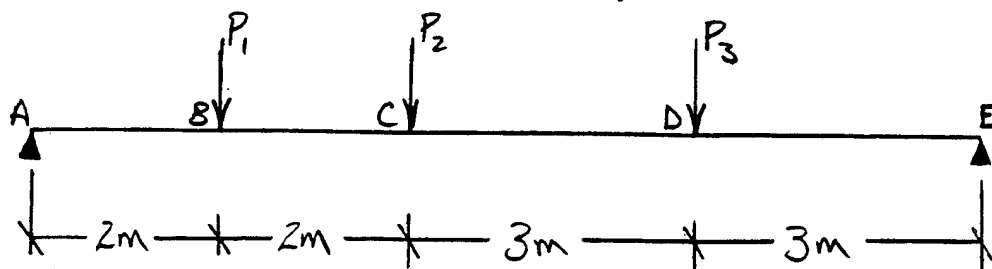

Loading

	Mean (kN)	C.O.V.
P1	3	8%
P2	5	12%
P3	8	10%

Load Correlation

Correlation Coefficients	Case <i>i</i>	Case <i>ii</i>
$\rho (P_1, P_2)$	0	1
$\rho (P_1, P_3)$	0	1
$\rho (P_2, P_3)$	0	1

Capacity

Shear: $V(R)_{\text{beam}} = 10\%$

Moment: $V(R)_{\text{beam}} = 10\%$

Sample Results

		$\min \beta$	x (m)	\bar{R}	\bar{S}	$V(S)$	Correlation
Shear (kN)	N	2.74	7 - 10	12.30	8.20	0.10	Case <i>ii</i>
	LN	2.83	7 - 10	12.30	8.20	0.10	Case <i>ii</i>
Moment (kN-m)	N	2.96	4.00	39.30	25.20	0.11	Case <i>ii</i>
	LN	3.05	4.00	39.30	25.20	0.11	Case <i>ii</i>

Beam System 1

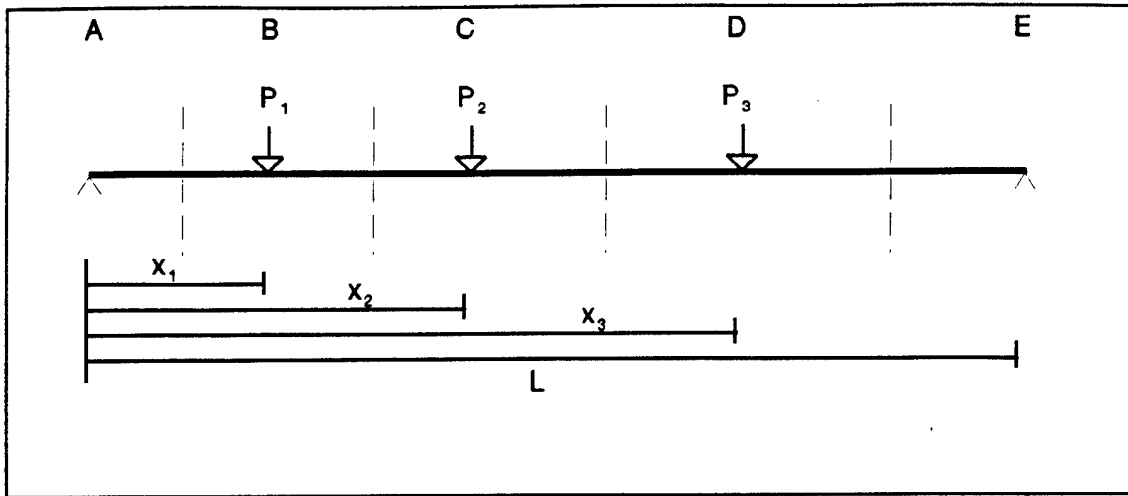

$$\begin{aligned}x_1 &= 2\text{m} \\x_2 &= 4\text{m} \\x_3 &= 7\text{m} \\L &= 10\text{m}\end{aligned}$$

STATICS

Sum of Forces (vertical)

$$\begin{aligned}\sum F_V &= 0 \\R_A + R_E &= P_1 + P_2 + P_3\end{aligned}$$

Sum of Moments (about point A)

$$\begin{aligned}\sum M_A &= 0 \rightarrow P_1(2\text{m}) + P_2(4\text{m}) + P_3(7\text{m}) - R_E(10\text{m}) \\R_E &= P_1\left(\frac{2}{10}\right) + P_2\left(\frac{4}{10}\right) + P_3\left(\frac{7}{10}\right)\end{aligned}$$

Sum of Moments (about point E)

$$\begin{aligned}\sum M_E &= 0 \\R_A &= P_1\left(\frac{8}{10}\right) + P_2\left(\frac{6}{10}\right) + P_3\left(\frac{3}{10}\right)\end{aligned}$$

Segment AB

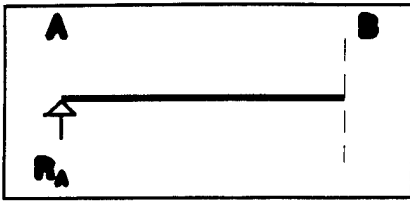

Shear

$$V = R_A$$
$$V = \left(\frac{8}{10}\right)P_1 + \left(\frac{6}{10}\right)P_2 + \left(\frac{3}{10}\right)P_3$$

Shear Dispersion

$$\sigma_{S_V}^2 = \sigma_{R_A}^2$$
$$\sigma_{S_V}^2 = \left(\frac{8}{10}\right)^2 \sigma_{P_1}^2 + \left(\frac{6}{10}\right)^2 \sigma_{P_2}^2 + \left(\frac{3}{10}\right)^2 \sigma_{P_3}^2 + 2\rho_{P_1 P_2} \left(\frac{8}{10}\right) \left(\frac{6}{10}\right) \sigma_{P_1} \sigma_{P_2}$$
$$+ 2\rho_{P_1 P_3} \left(\frac{8}{10}\right) \left(\frac{3}{10}\right) \sigma_{P_1} \sigma_{P_3} + 2\rho_{P_2 P_3} \left(\frac{6}{10}\right) \left(\frac{3}{10}\right) \sigma_{P_2} \sigma_{P_3}$$

Moment

$$M = R_A x$$
$$M = x \left[\left(\frac{8}{10}\right)P_1 + \left(\frac{6}{10}\right)P_2 + \left(\frac{3}{10}\right)P_3 \right]$$

Moment Dispersion

$$\sigma_{S_M}^2 = \left(\frac{8x}{10}\right)^2 \sigma_{P_1}^2 + \left(\frac{6x}{10}\right)^2 \sigma_{P_2}^2 + \left(\frac{3x}{10}\right)^2 \sigma_{P_3}^2 + 2\rho_{P_1 P_2} \left(\frac{8x}{10}\right) \left(\frac{6x}{10}\right) \sigma_{P_1} \sigma_{P_2}$$
$$+ 2\rho_{P_1 P_3} \left(\frac{8x}{10}\right) \left(\frac{3x}{10}\right) \sigma_{P_1} \sigma_{P_3} + 2\rho_{P_2 P_3} \left(\frac{6x}{10}\right) \left(\frac{3x}{10}\right) \sigma_{P_2} \sigma_{P_3}$$

Segment BC

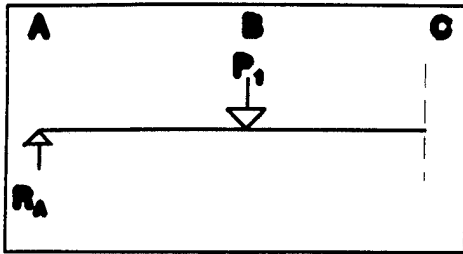

Shear

$$V = R_A - P_1$$

$$V = \left(\frac{-2}{10}\right)P_1 + \left(\frac{6}{10}\right)P_2 + \left(\frac{3}{10}\right)P_3$$

Shear Dispersion

$$\begin{aligned} \sigma_{S_V}^2 = & \left(\frac{-2}{10}\right)^2 \sigma_{P_1}^2 + \left(\frac{6}{10}\right)^2 \sigma_{P_2}^2 + \left(\frac{3}{10}\right)^2 \sigma_{P_3}^2 + 2\rho_{P_1 P_2} \left(\frac{-2}{10}\right) \left(\frac{6}{10}\right) \sigma_{P_1} \sigma_{P_2} \\ & + 2\rho_{P_1 P_3} \left(\frac{-2}{10}\right) \left(\frac{3}{10}\right) \sigma_{P_1} \sigma_{P_3} + 2\rho_{P_2 P_3} \left(\frac{6}{10}\right) \left(\frac{3}{10}\right) \sigma_{P_2} \sigma_{P_3} \end{aligned}$$

Moment

$$M = R_A x - P_1(x-x_1)$$

$$M = \left(2 - \frac{2}{10}x\right)P_1 + \left(\frac{6x}{10}\right)P_2 + \left(\frac{3x}{10}\right)P_3$$

Moment Dispersion

$$\begin{aligned} \sigma_{S_M}^2 = & \left(2 - \frac{2}{10}x\right)^2 \sigma_{P_1}^2 + \left(\frac{6x}{10}\right)^2 \sigma_{P_2}^2 + \left(\frac{3x}{10}\right)^2 \sigma_{P_3}^2 + 2\rho_{P_1 P_2} \left(2 - \frac{2}{10}x\right) \left(\frac{6x}{10}\right) \sigma_{P_1} \sigma_{P_2} \\ & + 2\rho_{P_1 P_3} \left(2 - \frac{2}{10}x\right) \left(\frac{3x}{10}\right) \sigma_{P_1} \sigma_{P_3} + 2\rho_{P_2 P_3} \left(\frac{6x}{10}\right) \left(\frac{3x}{10}\right) \sigma_{P_2} \sigma_{P_3} \end{aligned}$$

Segment CD

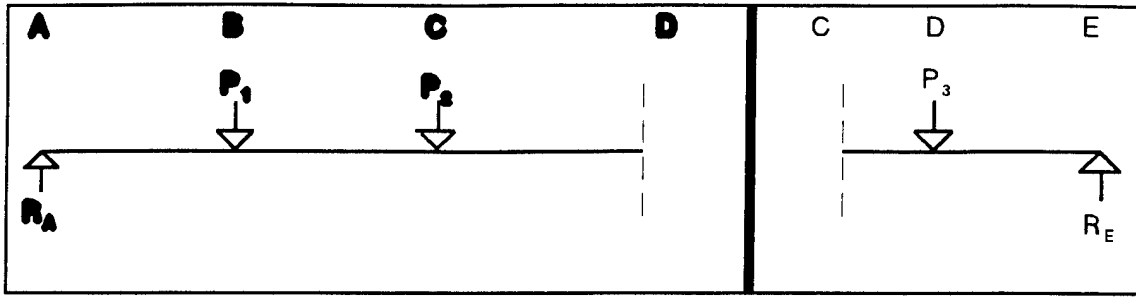

Shear

$$V = R_A - P_1 - P_2$$

$$V = \left(\frac{-2}{10}\right)P_1 + \left(\frac{-4}{10}\right)P_2 + \left(\frac{3}{10}\right)P_3$$

Shear Dispersion

$$\sigma_{S_V}^2 = \left(\frac{-2}{10}\right)^2 \sigma_{P_1}^2 + \left(\frac{-4}{10}\right)^2 \sigma_{P_2}^2 + \left(\frac{3}{10}\right)^2 \sigma_{P_3}^2 + 2\rho_{P_1 P_2} \left(\frac{-2}{10}\right) \left(\frac{-4}{10}\right) \sigma_{P_1} \sigma_{P_2}$$

$$+ 2\rho_{P_1 P_3} \left(\frac{-2}{10}\right) \left(\frac{3}{10}\right) \sigma_{P_1} \sigma_{P_3} + 2\rho_{P_2 P_3} \left(\frac{-4}{10}\right) \left(\frac{3}{10}\right) \sigma_{P_2} \sigma_{P_3}$$

Moment

$$M = R_A x - P_1(x-x_1) - P_2(x-x_2)$$

$$M = \left(2 - \frac{2}{10}x\right)P_1 + \left(4 - \frac{4}{10}x\right)P_2 + \left(\frac{3x}{10}\right)P_3$$

Moment Dispersion

$$\sigma_{S_M}^2 = \left(2 - \frac{2}{10}x\right)^2 \sigma_{P_1}^2 + \left(4 - \frac{4}{10}x\right)^2 \sigma_{P_2}^2 + \left(\frac{3x}{10}\right)^2 \sigma_{P_3}^2 + 2\rho_{P_1 P_2} \left(2 - \frac{2}{10}x\right) \left(4 - \frac{4}{10}x\right) \sigma_{P_1} \sigma_{P_2}$$

$$+ 2\rho_{P_1 P_3} \left(2 - \frac{2}{10}x\right) \left(\frac{3x}{10}\right) \sigma_{P_1} \sigma_{P_3} + 2\rho_{P_2 P_3} \left(4 - \frac{4}{10}x\right) \left(\frac{3x}{10}\right) \sigma_{P_2} \sigma_{P_3}$$

Segment DE

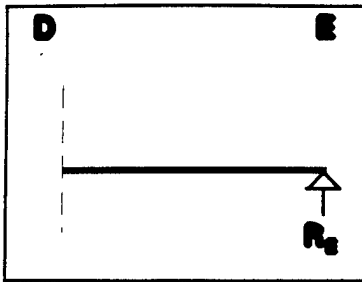

Shear

$$V = R_A - P_1 - P_2 - P_3 = -R_E$$

$$V = \left(\frac{-2}{10}\right)P_1 + \left(\frac{-4}{10}\right)P_2 + \left(\frac{-7}{10}\right)P_3$$

Shear Dispersion

$$\sigma_{S_V}^2 = \left(\frac{-2}{10}\right)^2 \sigma_{P_1}^2 + \left(\frac{-4}{10}\right)^2 \sigma_{P_2}^2 + \left(\frac{-7}{10}\right)^2 \sigma_{P_3}^2 + 2\rho_{P_1 P_2} \left(\frac{-2}{10}\right) \left(\frac{-4}{10}\right) \sigma_{P_1} \sigma_{P_2}$$

$$+ 2\rho_{P_1 P_3} \left(\frac{-2}{10}\right) \left(\frac{-7}{10}\right) \sigma_{P_1} \sigma_{P_3} + 2\rho_{P_2 P_3} \left(\frac{-4}{10}\right) \left(\frac{-7}{10}\right) \sigma_{P_2} \sigma_{P_3}$$

Moment

$$M = R_A x - P_1(x-x_1) - P_2(x-x_2) - P_3(x-x_3) = (L-x)R_E$$

$$M = \left(2 - \frac{2}{10}x\right)P_1 + \left(4 - \frac{4}{10}x\right)P_2 + \left(7 - \frac{7}{10}x\right)P_3$$

Moment Dispersion

$$\sigma_{S_M}^2 = \left(2 - \frac{2}{10}x\right)^2 \sigma_{P_1}^2 + \left(4 - \frac{4}{10}x\right)^2 \sigma_{P_2}^2 + \left(7 - \frac{7}{10}x\right)^2 \sigma_{P_3}^2$$

$$+ 2\rho_{P_1 P_2} \left(2 - \frac{2}{10}x\right) \left(4 - \frac{4}{10}x\right) \sigma_{P_1} \sigma_{P_2}$$

$$+ 2\rho_{P_1 P_3} \left(2 - \frac{2}{10}x\right) \left(7 - \frac{7}{10}x\right) \sigma_{P_1} \sigma_{P_3} + 2\rho_{P_2 P_3} \left(4 - \frac{4}{10}x\right) \left(7 - \frac{7}{10}x\right) \sigma_{P_2} \sigma_{P_3}$$

Mean Shear Diagram

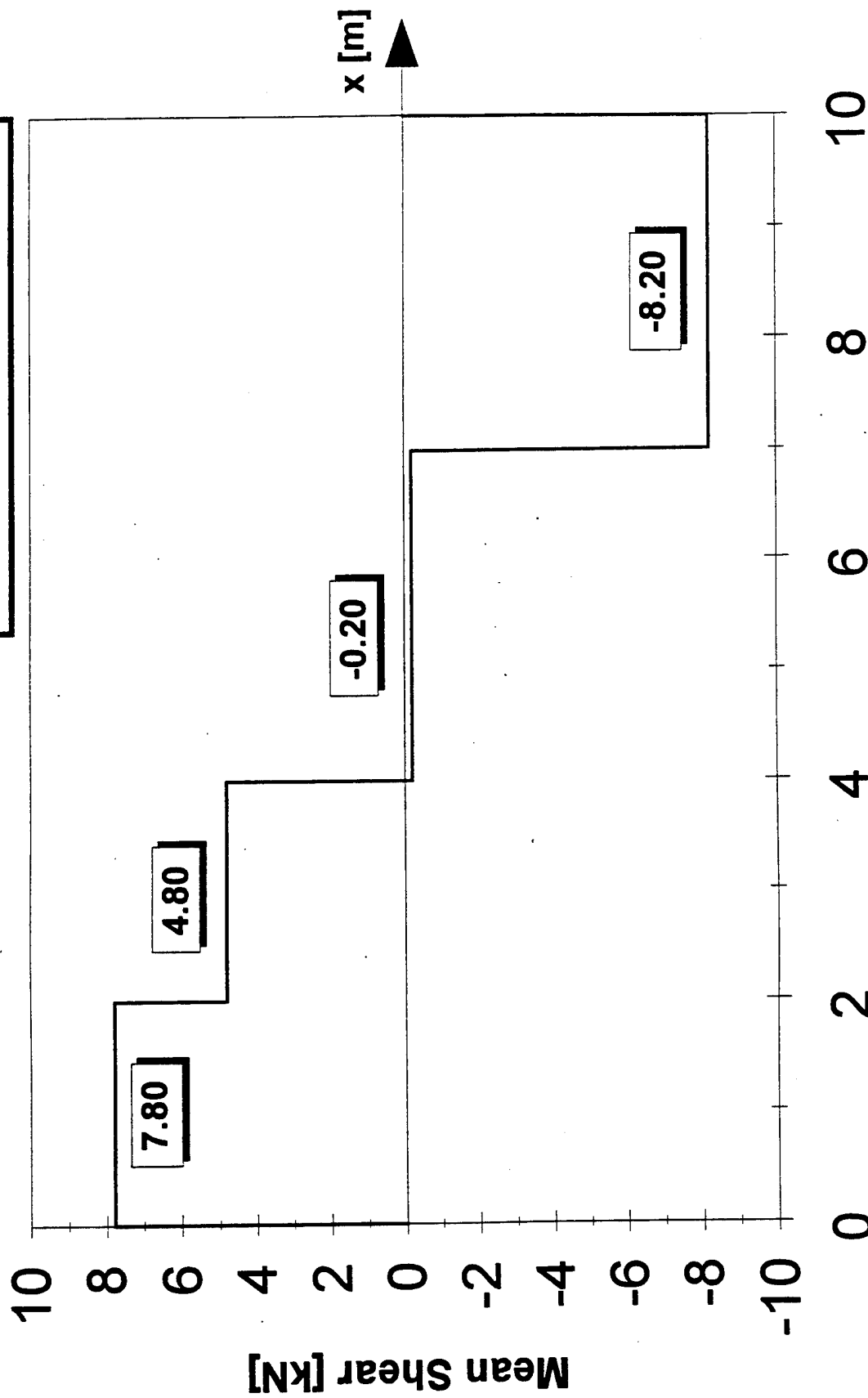

Shear Dispersion Diagram

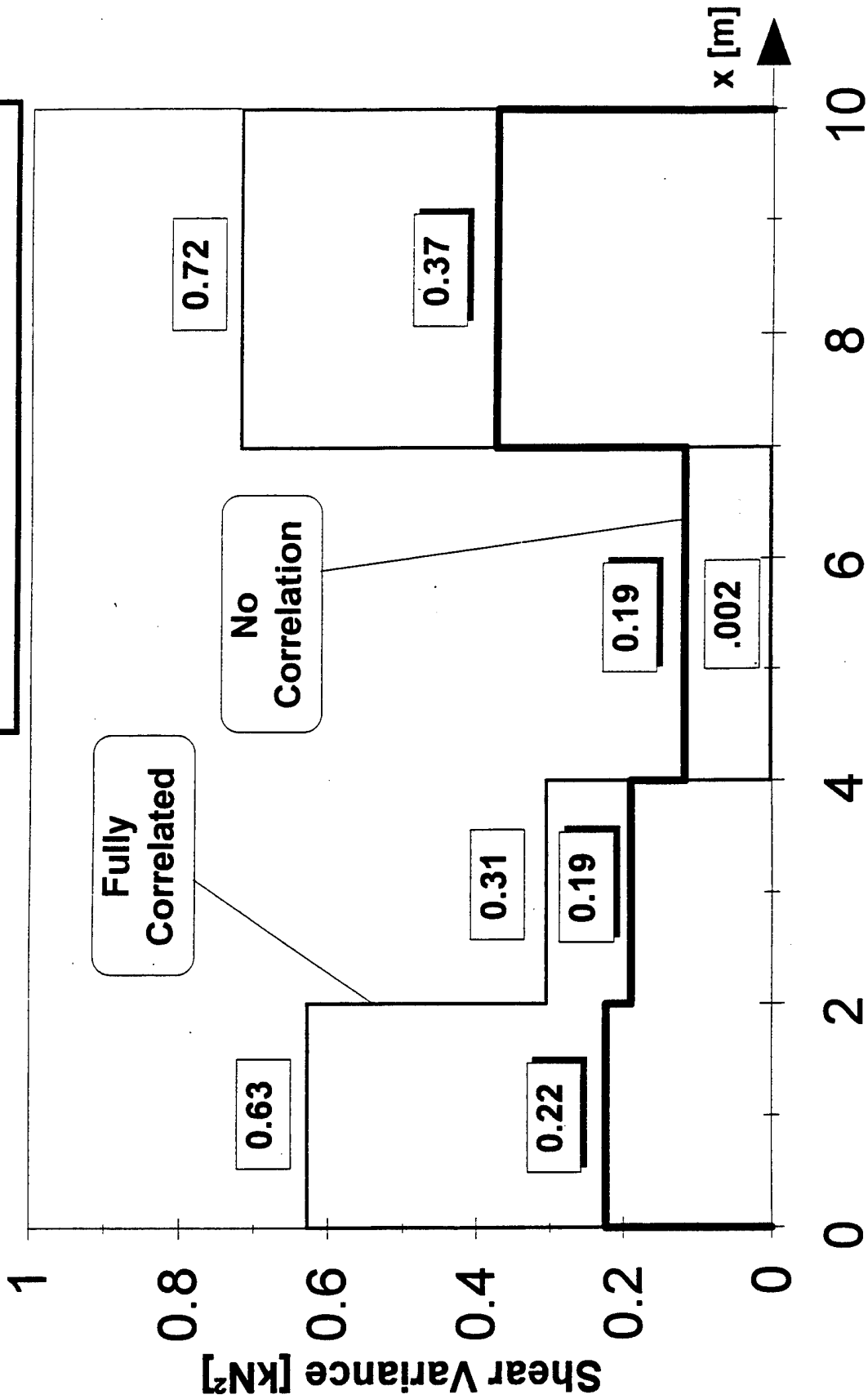

Mean Moment Diagram

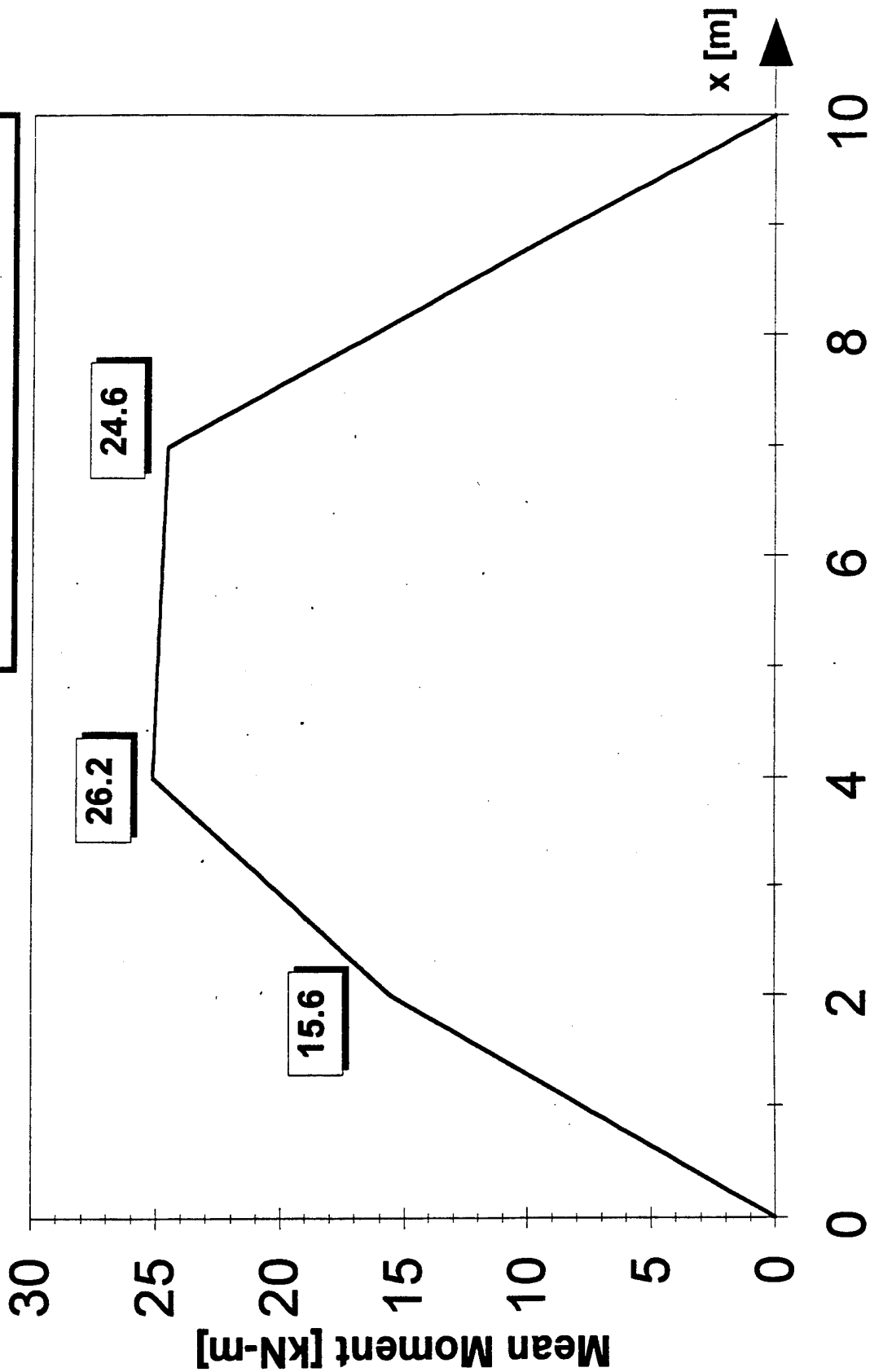

Moment Dispersion Diagram

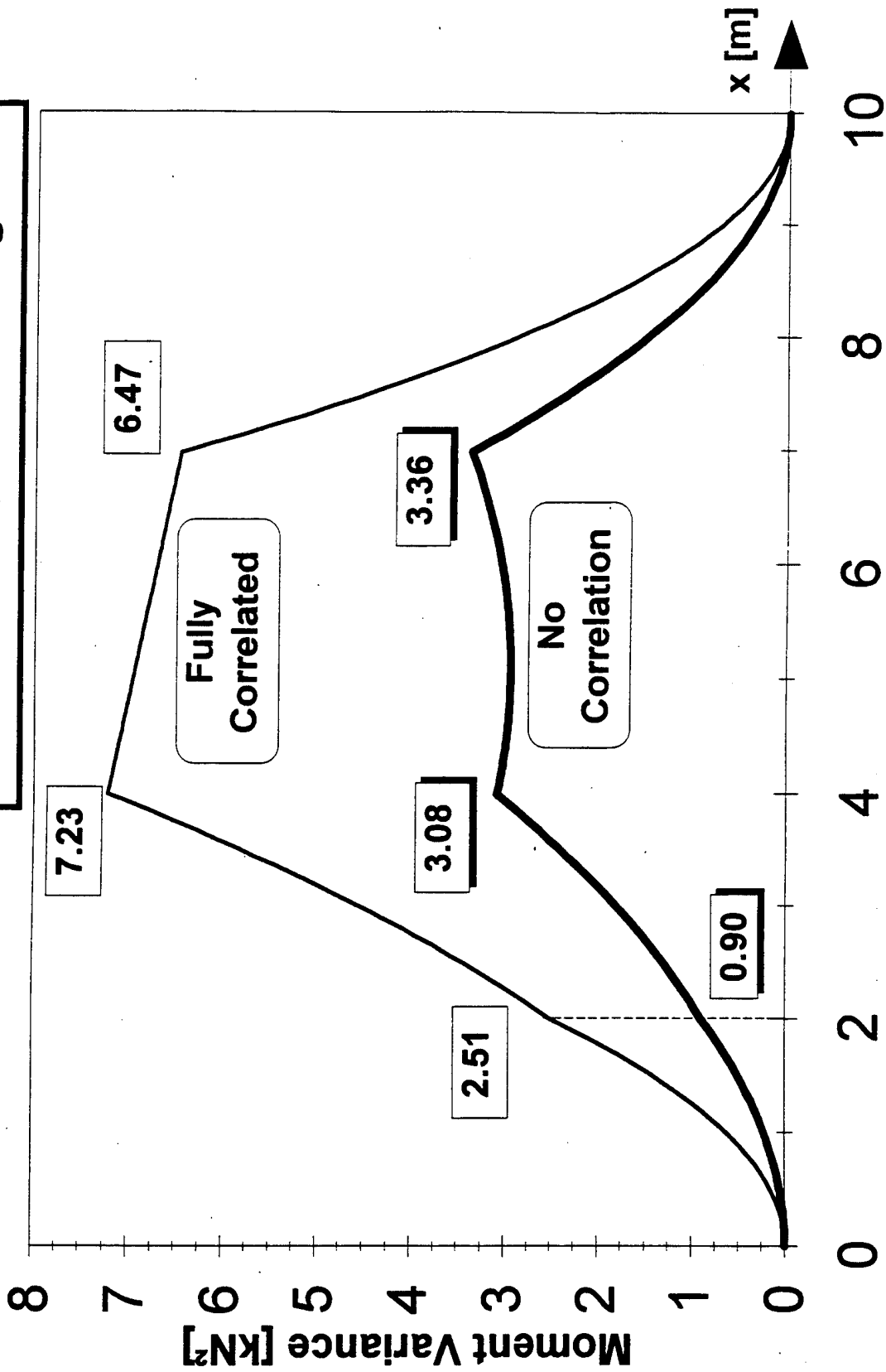

Shear Reliability Diagram

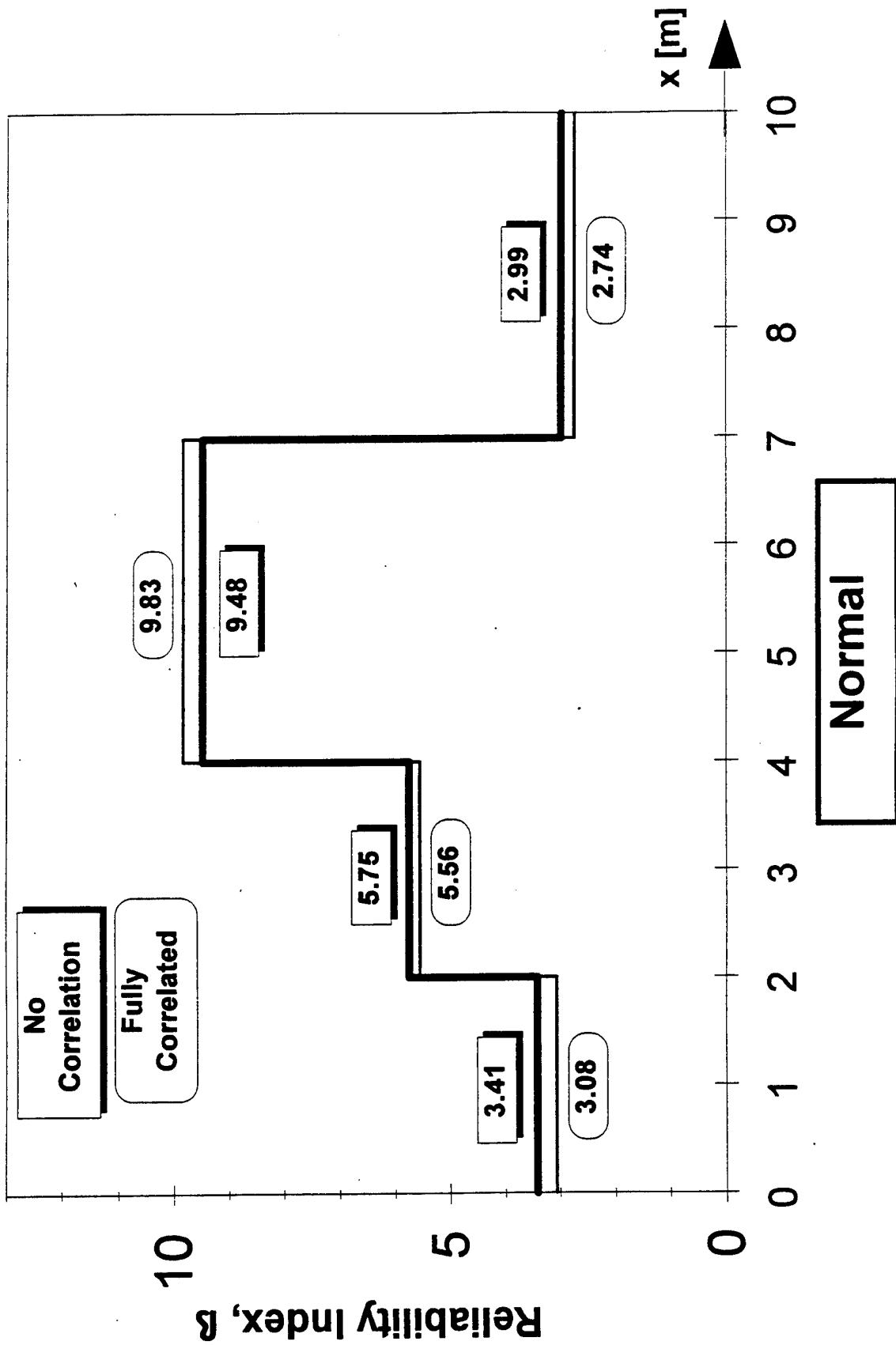

Shear Reliability Diagram

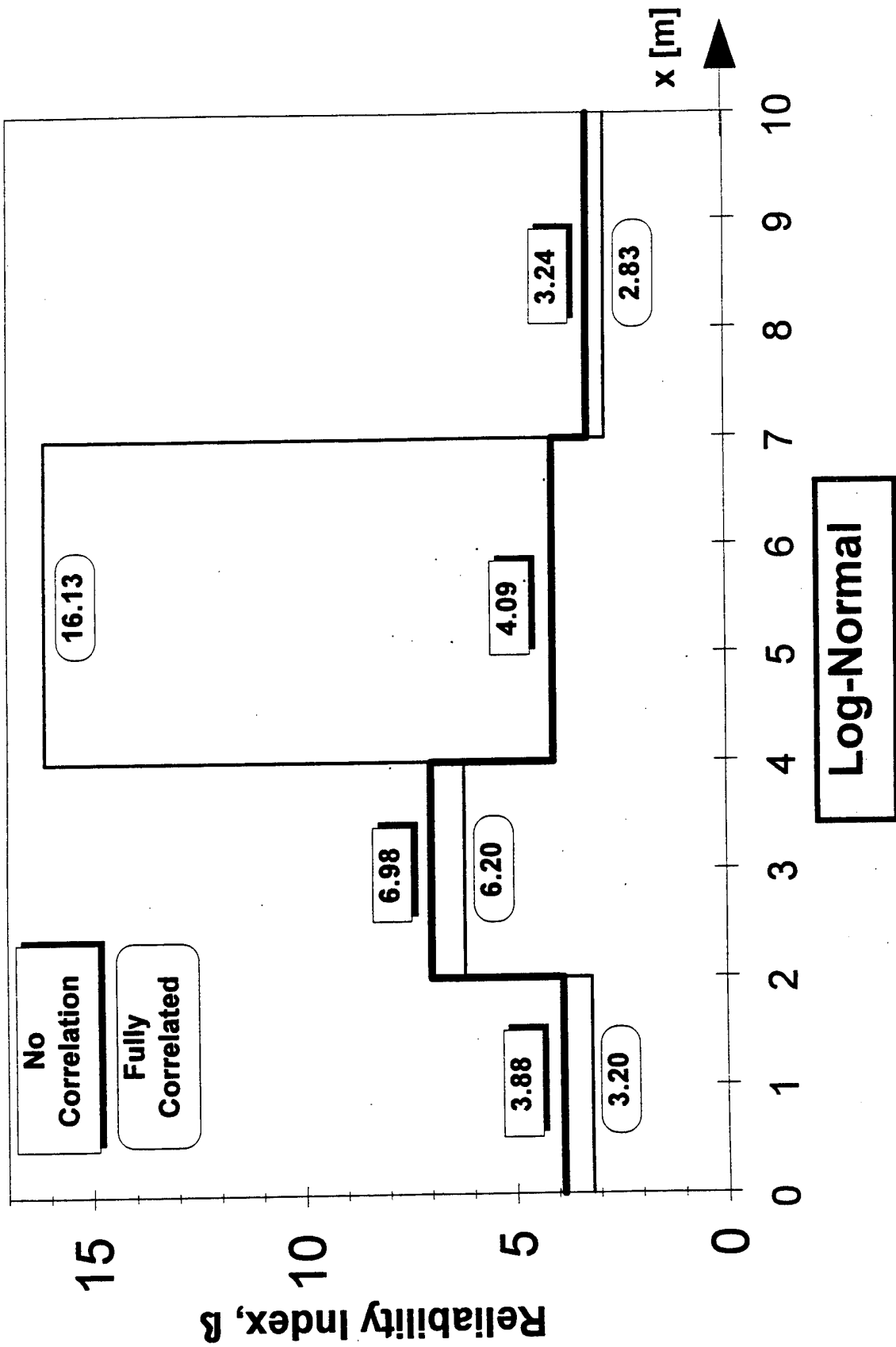

Shear "Factor of Safety" Diagram

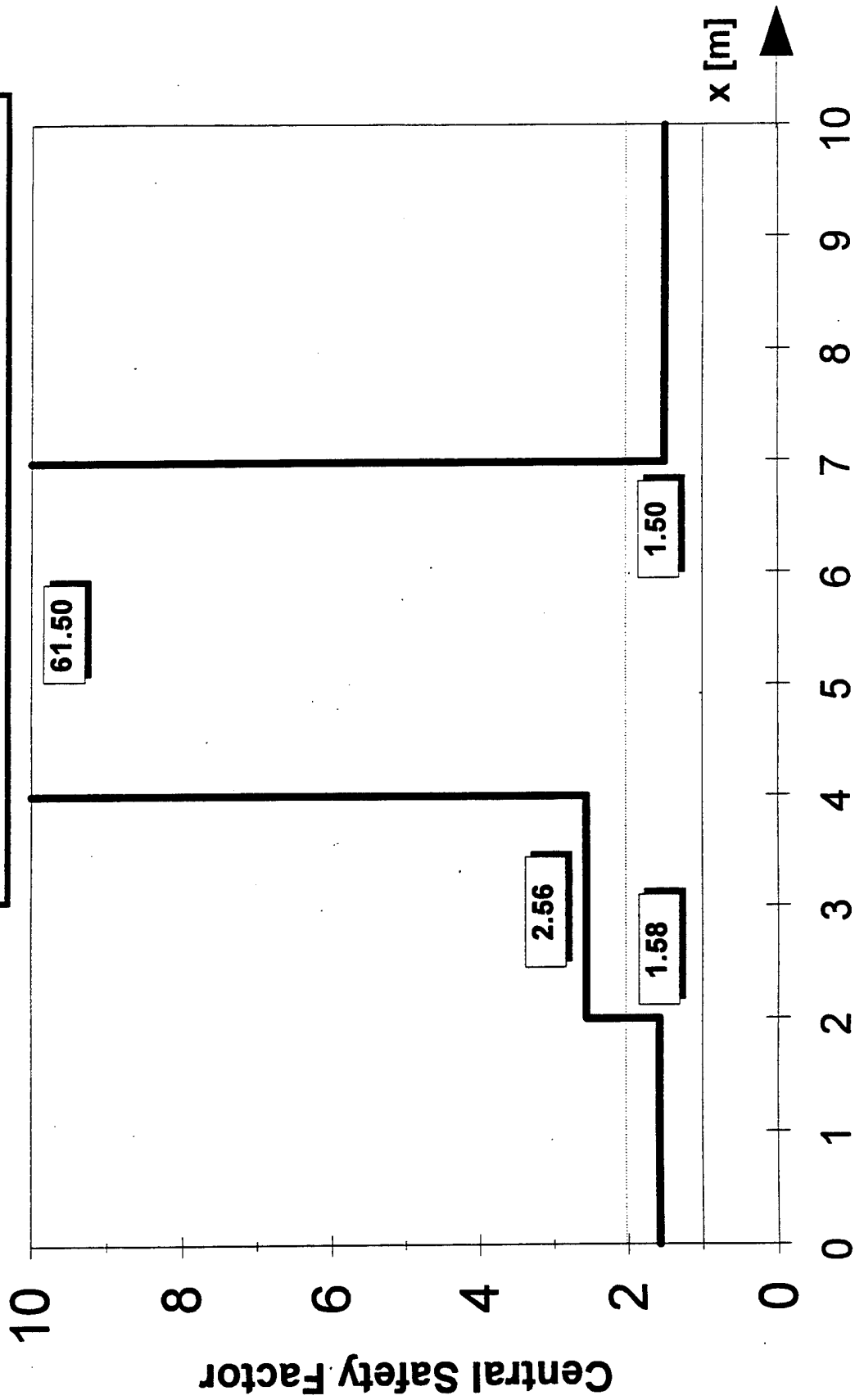

Moment Reliability Diagram

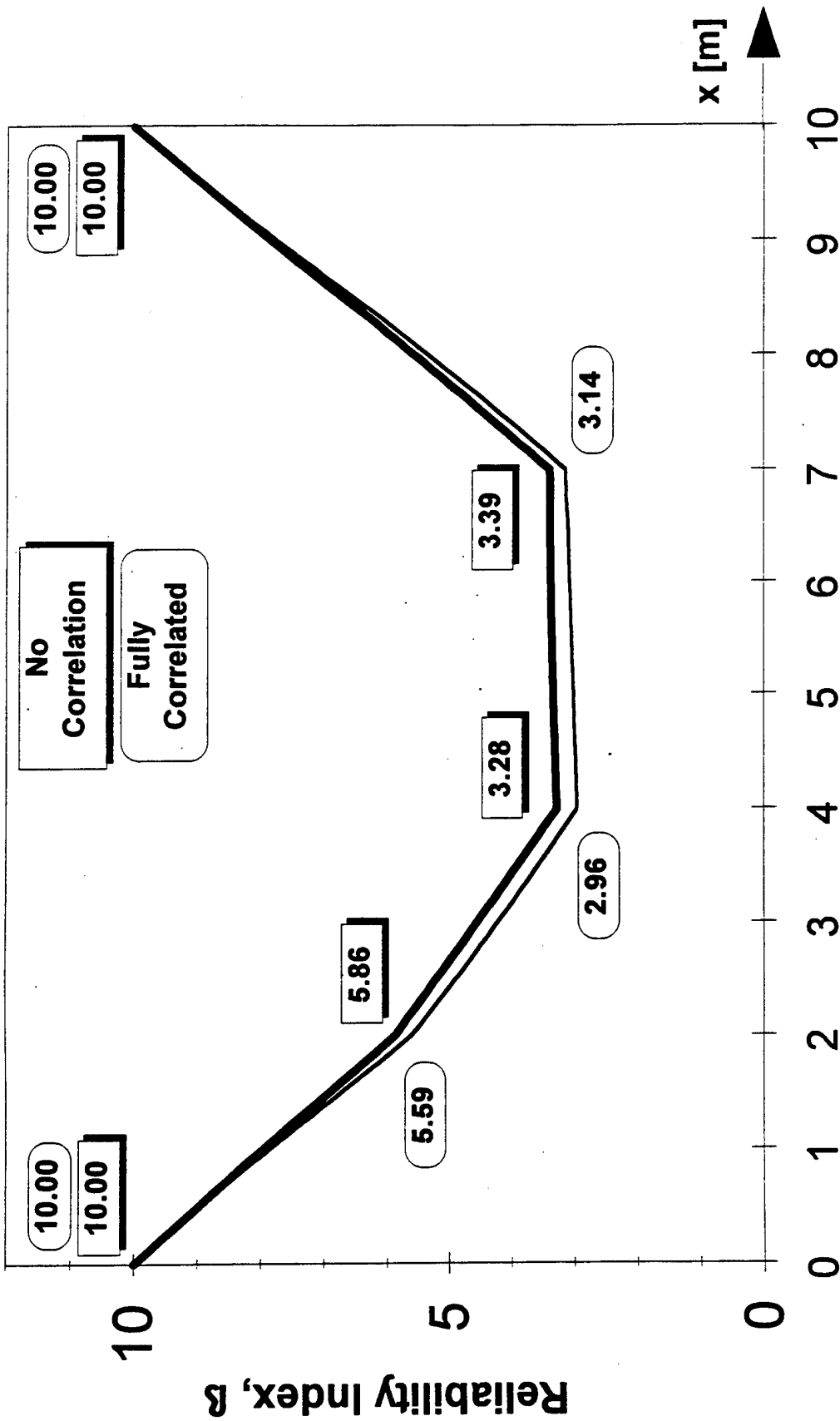

Normal

Moment Reliability Diagram

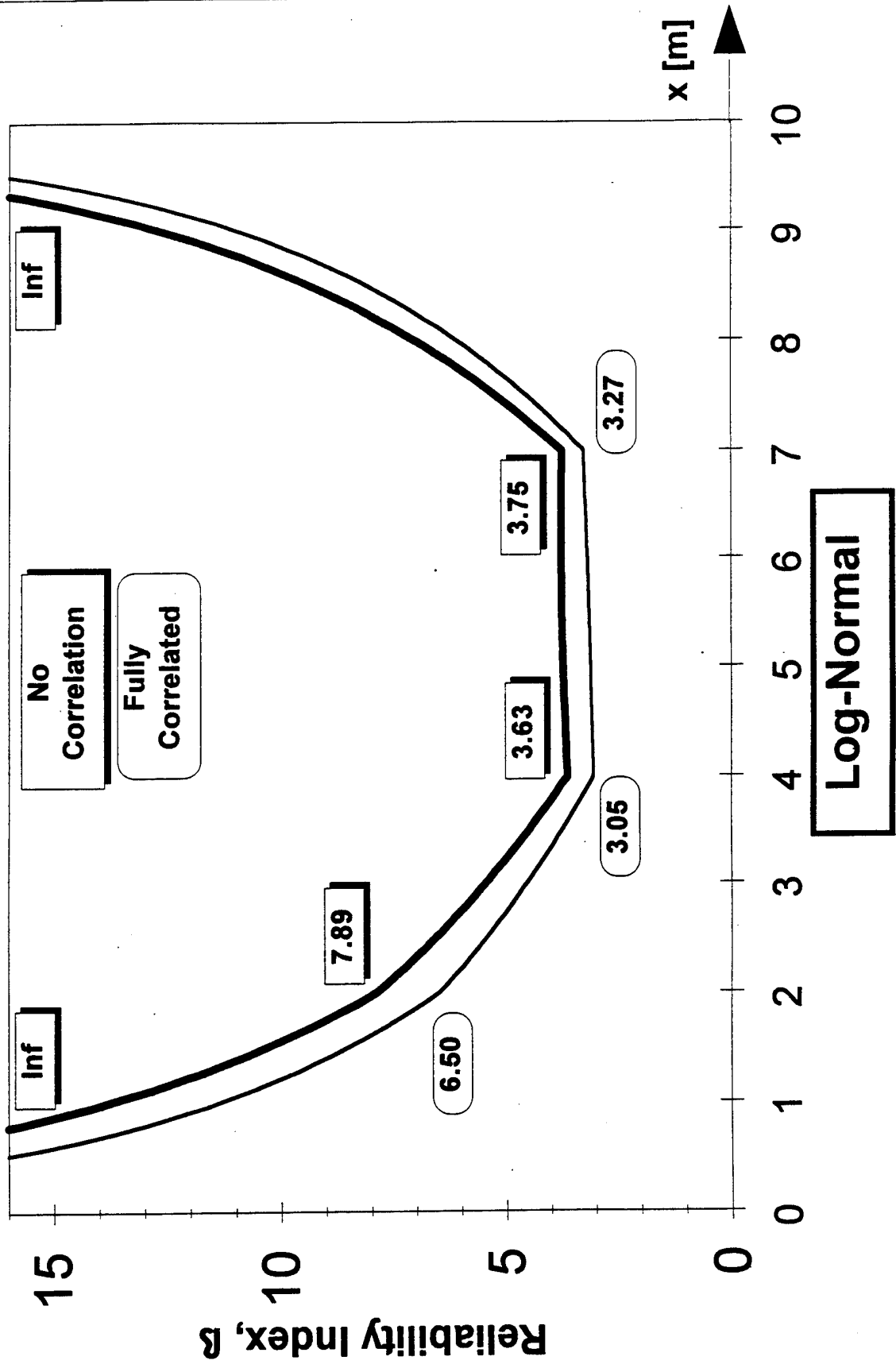

Log-Normal

Moment "Factor of Safety" Diagram

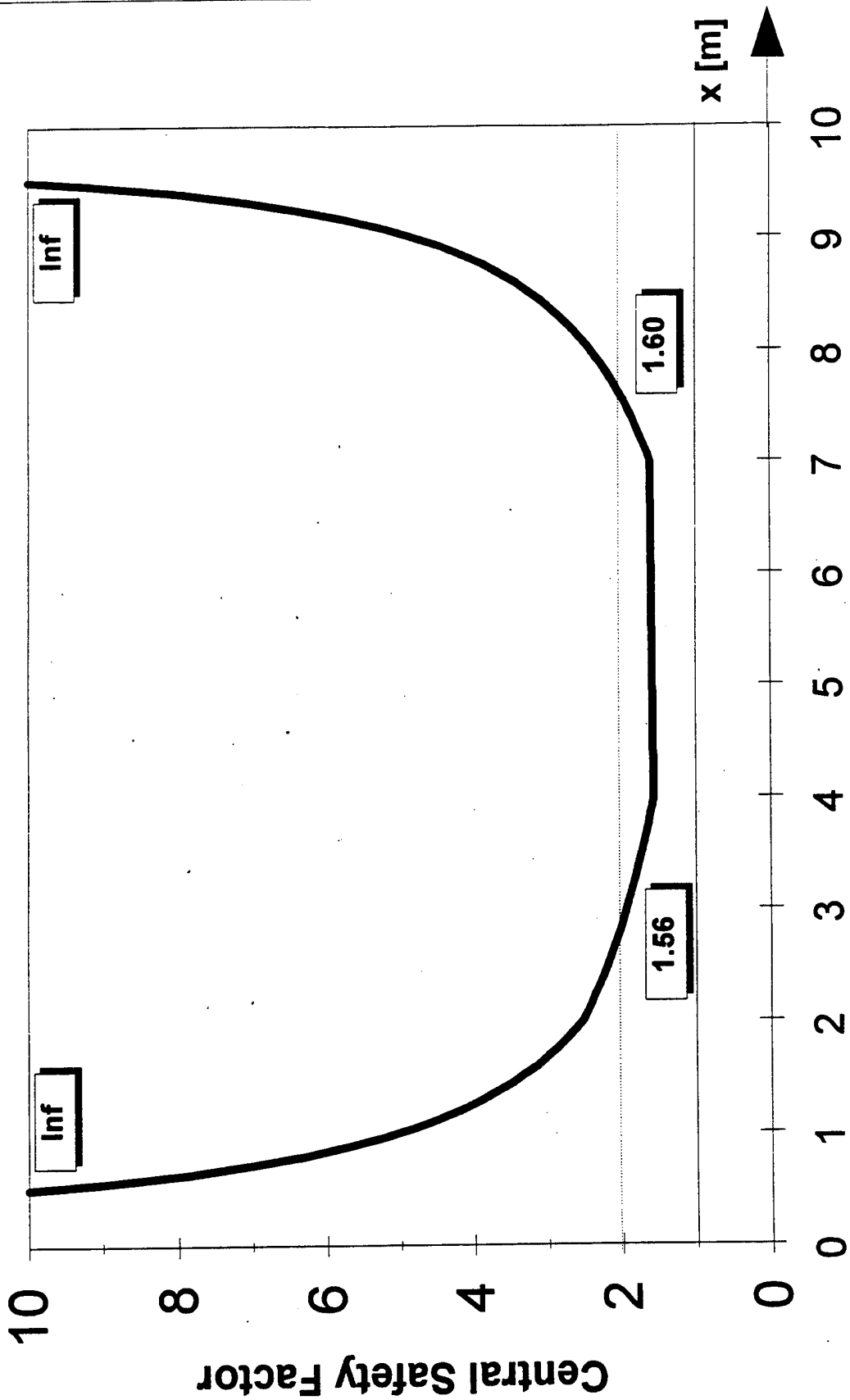

Reliability Index vs Safety Factor in Structures

Appendix B B2

Sample System 2

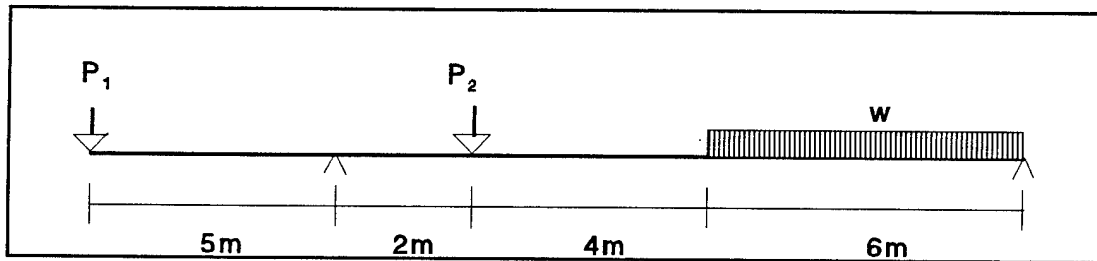

Figure 3.1b *Simply Supported Beam, Cantilevered Left End (Laursen, p. 46, #2-8)*

Contents

- 1-1 Reliability Analysis Step problem statement and minimum β results
- 1-2 Design Step problem statement and minimum β results
- 2 Piecewise equations
- 3 Structural Analysis of Loads Diagrams
- 4 Reliability Analysis Step Reliability and Safety Factor Diagrams
- 5 Design Step Reliability and Safety Factor Diagrams

SAMPLE SYSTEM 2

Simply Supported Beam, Cantilevered Left End

Three random loads

Two concentrated loads, One distributed load

Assume normal, then log-normal, distribution for load and resistance

Uniform beam

Problem (Calibration) Find location of minimum reliability.

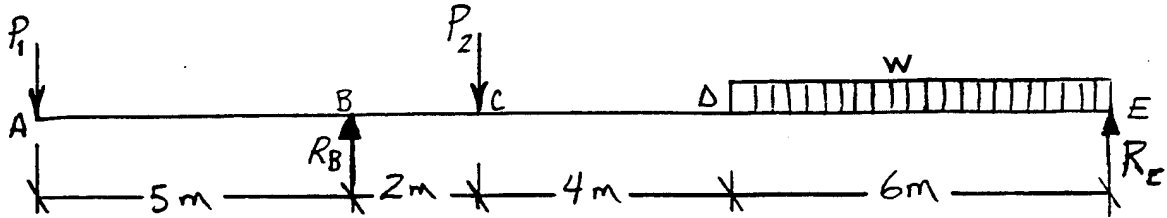

Loading

	Mean		C.O.V.
	(kN)	(kN/m)	
P1	5	-	12%
P2	10	-	6%
P3	-	2	8%

Load Correlation

Correlation Coefficients	Case i	Case ii	Case iii
$\rho (P_1, P_2)$	0	1	1
$\rho (P_1, w)$	0	0	1
$\rho (P_2, w)$	0	0	1

Capacity

Shear: $\bar{R} = 18 \text{ kN}$, $V(R)_{\text{beam}} = 8\%$

Moment: $\bar{R} = 30 \text{ kN-m}$, $V(R)_{\text{beam}} = 6\%$

Sample Results

		min β	x (m)	\bar{S}	V(S)	Correlation
Shear (kN)	N	2.62	5 - 7	13.42	0.07	Case ii
Moment (kN-m)	N	1.43	5.00	25.00	0.12	any case

SAMPLE SYSTEM 2

Simply Supported Beam, Cantilevered Left End

Three random loads

Two concentrated loads, One distributed load

Assume normal, then log-normal, distribution for load and resistance

Uniform beam

Problem Find location of minimum reliability.

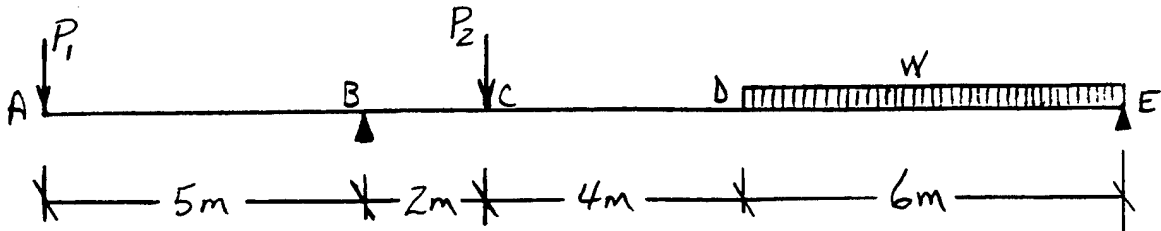

Loading

	Mean		C.O.V.
	(kN)	(KN/m)	
P1	5	-	12%
P2	10	-	6%
w	-	2	8%

Load Correlation

Correlation Coefficients	Case i	Case ii	Case iii
$\rho (P_1, P_2)$	0	1	1
$\rho (P_1, w)$	0	0	1
$\rho (P_2, w)$	0	0	1

Capacity

Shear: $V(R)_{\text{beam}} = 10\%$

Moment: $V(R)_{\text{beam}} = 10\%$

Sample Results

		min β	x (m)	\bar{R}	\bar{S}	V(S)	Correlation
Shear (kN)	N	2.62	5 - 7	18.00	13.42	0.07	Case iii
	LN	2.70	5 - 7	18.00	13.42	0.07	Case iii
Moment (kN-m)	N	2.73	5.00	35.00	25.00	0.12	any case
	LN	2.56	5.00	35.00	25.00	0.12	any case

Beam System 2

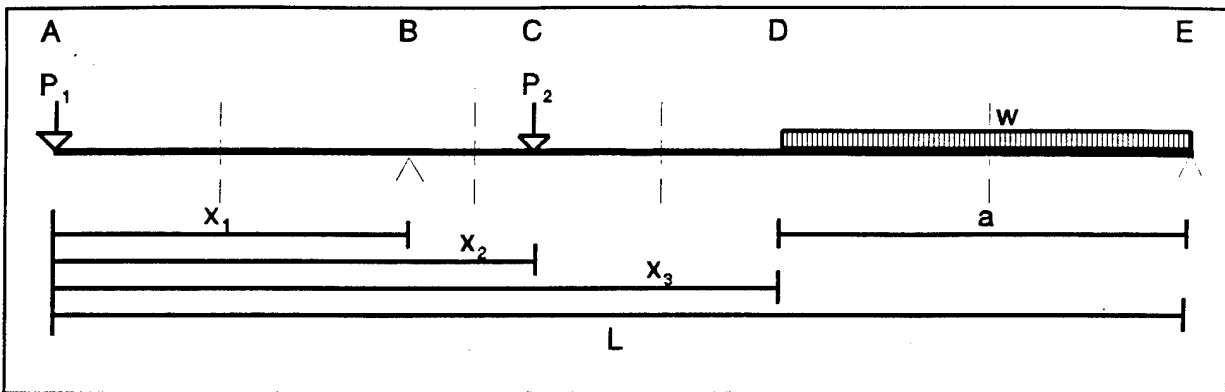

$$\begin{aligned}x_1 &= 5\text{m} \\x_2 &= 7\text{m} \\x_3 &= 11\text{m} \\L &= 17\text{m}\end{aligned}$$

STATICS

Sum of Forces (vertical)

$$\begin{aligned}\sum F_V &= 0 \\R_A + R_E &= P_1 + P_2 + aw\end{aligned}$$

Sum of Moments (about point E)

$$\begin{aligned}\sum M_E = 0 &\rightarrow P_1(L) - R_B(L-x_1) + P_2(L-x_2) + w(a)\left(\frac{a}{2}\right) \\R_B &= \left(\frac{17}{12}\right)P_1 + \left(\frac{10}{12}\right)P_2 + \left(\frac{3}{12}\right)aw\end{aligned}$$

Sum of Moments (about point B)

$$\sum M_B = 0 \rightarrow R_E = \left(\frac{5}{12}\right)P_1 - \left(\frac{2}{12}\right)P_2 - \left(\frac{9}{12}\right)aw$$

Segment AB

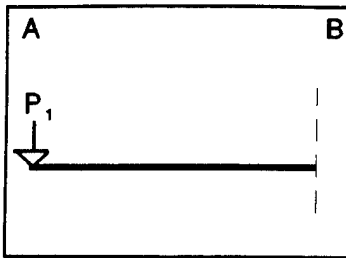

Shear

$$V_{AB} = -P_1$$

Shear Dispersion

$$\sigma_{S_V}^2 = (-1)^2 \sigma_{P_1}^2 = \sigma_{P_1}^2$$

Moment

$$M = -P_1 x$$

Moment Dispersion

$$\sigma_{S_M}^2 = (-x)^2 \sigma_{P_1}^2 = x^2 \sigma_{P_1}^2$$

Segment BC

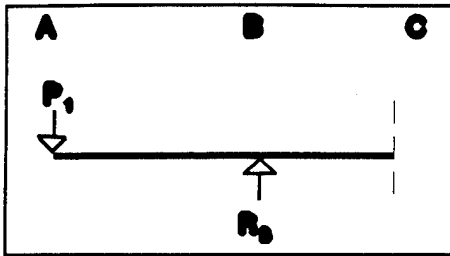

Shear

$$V = -P_1 + R_B$$

$$V = \left(\frac{5}{12}\right)P_1 + \left(\frac{10}{12}\right)P_2 + \left(\frac{3}{12}\right)aw$$

Shear Dispersion

$$\sigma_{S_V}^2 = \left(\frac{5}{12}\right)^2 \sigma_{P_1}^2 + \left(\frac{10}{12}\right)^2 \sigma_{P_2}^2 + \left(\frac{3a}{12}\right)^2 \sigma_w^2$$

$$+ 2\rho_{P_1 P_2} \left(\frac{5}{12}\right) \left(\frac{10}{12}\right) \sigma_{P_1} \sigma_{P_2}$$

$$+ 2\rho_{P_1 w} \left(\frac{5}{12}\right) \left(\frac{3a}{12}\right) \sigma_{P_1} \sigma_w + 2\rho_{P_2 w} \left(\frac{10}{12}\right) \left(\frac{3a}{12}\right) \sigma_{P_2} \sigma_w$$

Moment

$$M = -P_1 x + R_B (x - x_1)$$

$$M = \left(\frac{5}{12}x - \frac{85}{12}\right)P_1 + \left(\frac{10}{12}x - \frac{50}{12}\right)P_2 + \left(\frac{3}{12}x - \frac{15}{12}\right)aw$$

Moment Dispersion

$$\sigma_{S_M}^2 = \left(\frac{5x-85}{12}\right)^2 \sigma_{P_1}^2 + \left(\frac{10x-50}{12}\right)^2 \sigma_{P_2}^2 + \left(\frac{3ax-15a}{12}\right)^2 \sigma_w^2$$

$$+ 2\rho_{P_1 P_2} \left(\frac{5x-85}{12}\right) \left(\frac{10x-50}{12}\right) \sigma_{P_1} \sigma_{P_2}$$

$$+ 2\rho_{P_1 w} \left(\frac{5x-85}{12}\right) \left(\frac{3ax-15}{12}\right) \sigma_{P_1} \sigma_w + 2\rho_{P_2 w} \left(\frac{10x-50}{12}\right) \left(\frac{3ax-15}{12}\right) \sigma_{P_2} \sigma_w$$

Segment CD

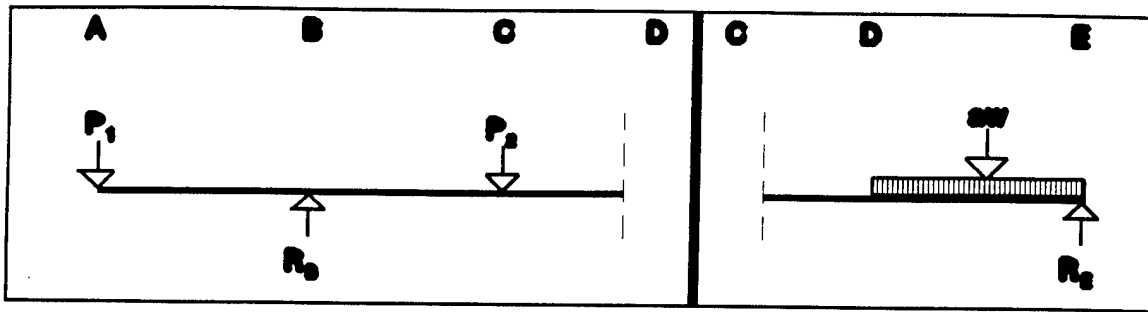

Shear

$$V = -P_1 + R_B - P_2$$

$$V = \left(\frac{5}{12}\right)P_1 - \left(\frac{2}{12}\right)P_2 + \left(\frac{3}{12}\right)aw$$

Shear Dispersion

$$\sigma_{S_V}^2 = \left(\frac{5}{12}\right)^2 \sigma_{P_1}^2 + \left(\frac{-2}{12}\right)^2 \sigma_{P_2}^2 + \left(\frac{3a}{12}\right)^2 \sigma_w^2 + 2\rho_{P_1 P_2} \left(\frac{5}{12}\right) \left(\frac{-2}{12}\right) \sigma_{P_1} \sigma_{P_2}$$

$$+ 2\rho_{P_1 w} \left(\frac{5}{12}\right) \left(\frac{3a}{12}\right) \sigma_{P_1} \sigma_w + 2\rho_{P_2 w} \left(\frac{-2}{12}\right) \left(\frac{3a}{12}\right) \sigma_{P_2} \sigma_w$$

Moment

$$M = -P_1 x - R_B(x-x_1) - P_2(x-x_2)$$

$$M = \left(\frac{5}{12}x - \frac{85}{12}\right)P_1 + \left(\frac{-2}{12}x - \frac{34}{12}\right)P_2 + \left(\frac{3}{12}x - \frac{15}{12}\right)aw$$

Moment Dispersion

$$\sigma_{S_M}^2 = \left(\frac{5x-85}{12}\right)^2 \sigma_{P_1}^2 + \left(\frac{34-2x}{12}\right)^2 \sigma_{P_2}^2 + \left(\frac{3ax-15a}{12}\right)^2 \sigma_w^2 + 2\rho_{P_1 P_2} \left(\frac{5x-85}{12}\right) \left(\frac{34-2x}{12}\right) \sigma_{P_1} \sigma_{P_2}$$

$$+ 2\rho_{P_1 w} \left(\frac{5x-85}{12}\right) \left(\frac{3ax-15a}{12}\right) \sigma_{P_1} \sigma_w + 2\rho_{P_2 w} \left(\frac{34-2x}{12}\right) \left(\frac{3ax-15a}{12}\right) \sigma_{P_2} \sigma_w$$

Segment DE

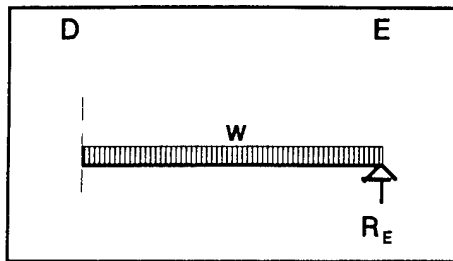

Shear

$$V = -P_1 + R_B - P_2 - w(x-11) = -R_E$$

$$V = \left(\frac{5}{12}\right)P_1 + \left(\frac{-2}{12}\right)P_2 + \left[\left(\frac{3a}{12} + 11\right) - x\right]aw$$

Shear Dispersion

$$\sigma_{S_V}^2 = \left(\frac{5}{12}\right)^2 \sigma_{P_1}^2 + \left(\frac{-2}{12}\right)^2 \sigma_{P_2}^2 + \left(\frac{3a+132}{12} - x\right)^2 \sigma_w^2 + 2\rho_{P_1 P_2} \left(\frac{5}{12}\right) \left(\frac{-2}{12}\right) \sigma_{P_1} \sigma_{P_2}$$

$$+ 2\rho_{P_1 w} \left(\frac{5}{12}\right) \left(\frac{3a+132}{12} - x\right) \sigma_{P_1} \sigma_w + 2\rho_{P_2 w} \left(\frac{-2}{12}\right) \left(\frac{3a+132}{12} - x\right) \sigma_{P_2} \sigma_w$$

Moment

$$M = -P_1 x - R_B(x-x_1) - P_2(x-x_2) - P_3(x-x_3)$$

$$M = \left(\frac{5}{12}x - \frac{85}{12}\right)P_1 + \left(\frac{-2}{12}x - \frac{34}{12}\right)P_2 + \left[\frac{3a+132}{12}x - \frac{15a+726}{12} - \frac{1}{2}x^2\right]aw$$

Moment Dispersion

$$\sigma_{S_M}^2 = \left(\frac{5x-85}{12}\right)^2 \sigma_{P_1}^2 + \left(\frac{34-2x}{12}\right)^2 \sigma_{P_2}^2 + \left[\left(\frac{3a+132}{12}\right)x - \left(\frac{15a+726}{12}\right) - \frac{1}{2}x^2\right]^2 \sigma_w^2$$

$$+ 2\rho_{P_1 P_2} \left(\frac{5x-85}{12}\right) \left(\frac{34-2x}{12}\right) \sigma_{P_1} \sigma_{P_2} + 2\rho_{P_1 w} \left(\frac{5x-85}{12}\right) \left[\left(\frac{3a+132}{12}\right)x - \left(\frac{15a+726}{12}\right) - \frac{1}{2}x^2\right] \sigma_{P_1} \sigma_w$$

$$+ 2\rho_{P_2 w} \left(\frac{34-2x}{12}\right) \left[\left(\frac{3a+132}{12}\right)x - \left(\frac{15a+726}{12}\right) - \frac{1}{2}x^2\right] \sigma_{P_2} \sigma_w$$

Shear Diagram

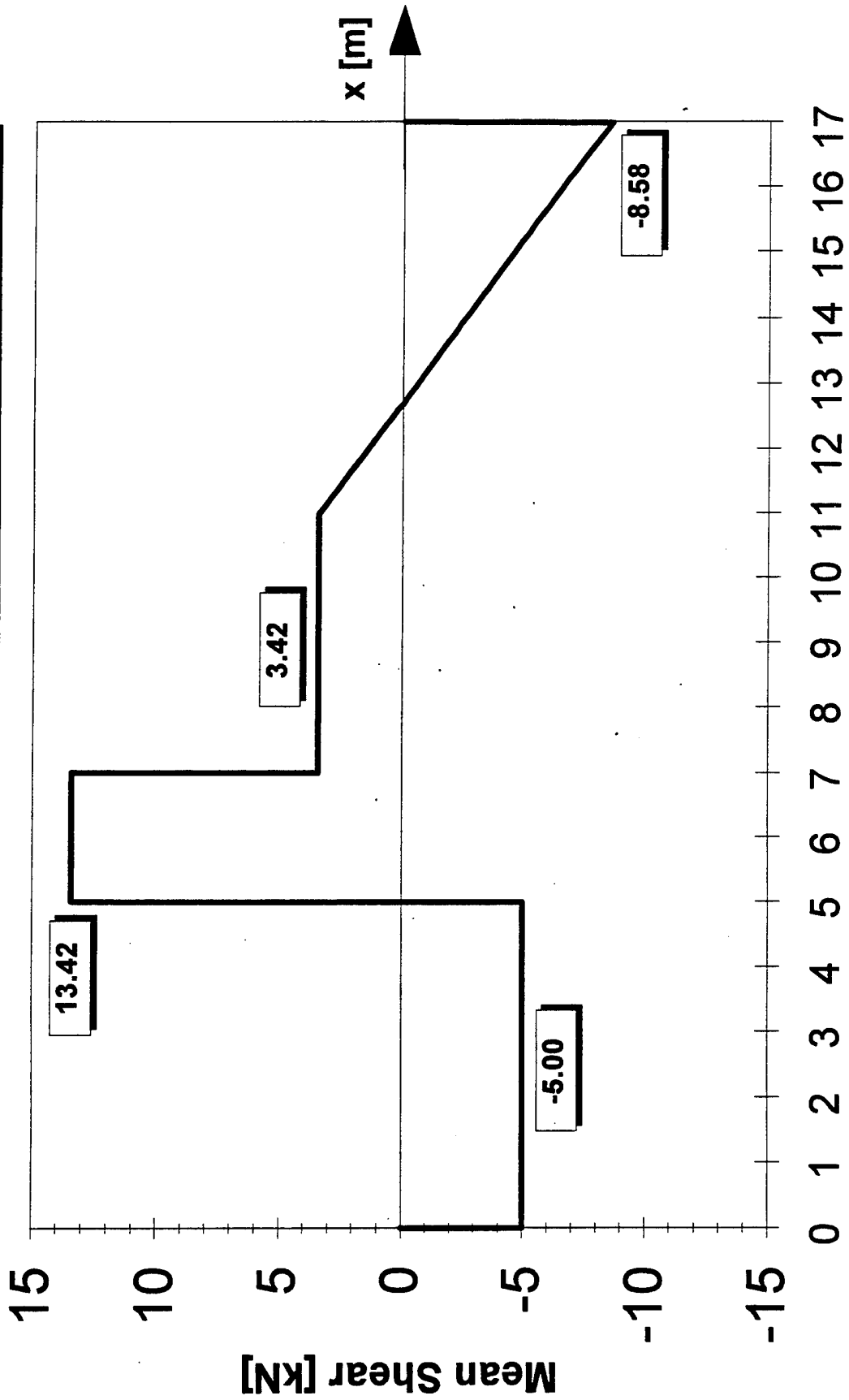

Shear Dispersion Diagram

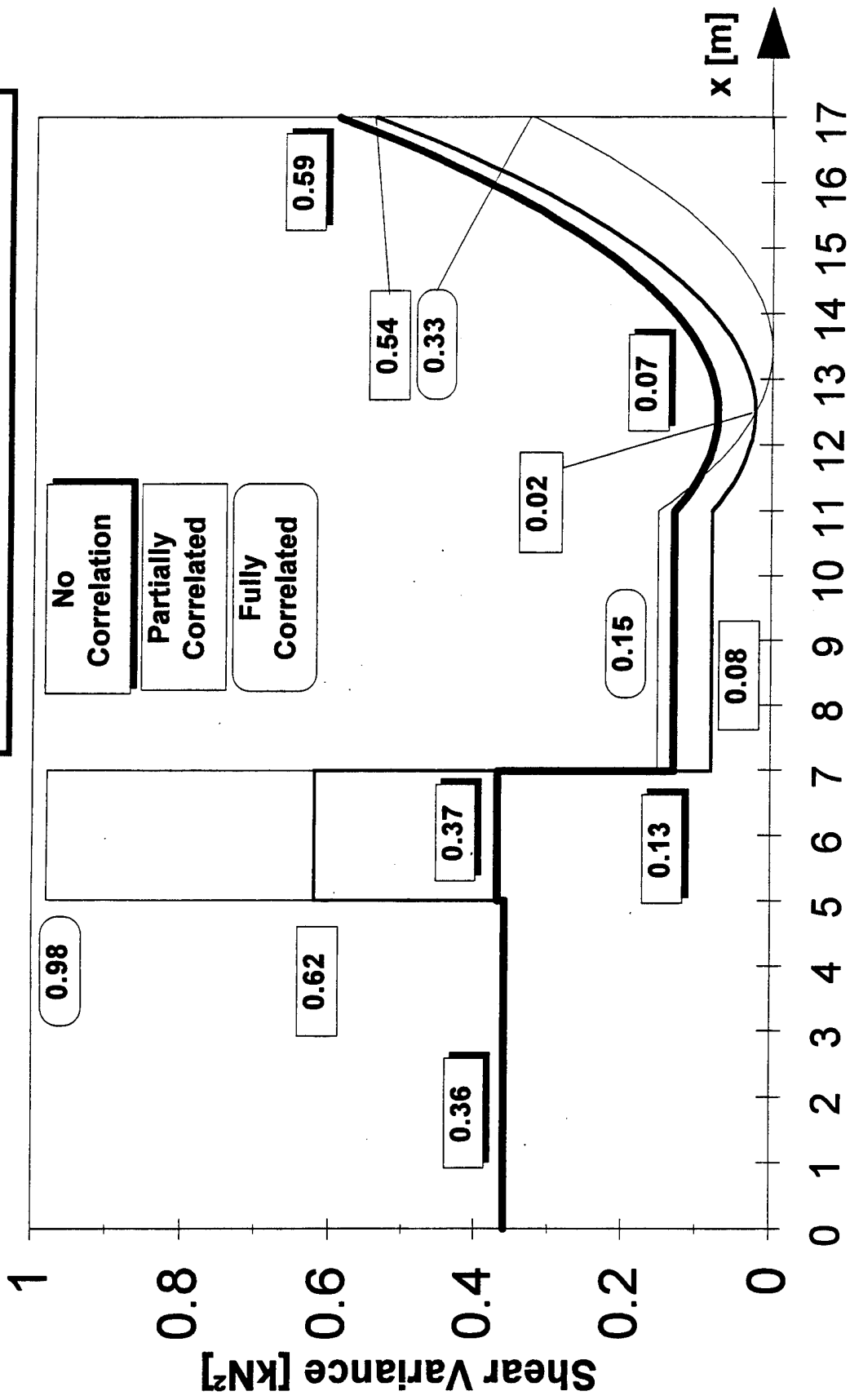

Moment Diagram

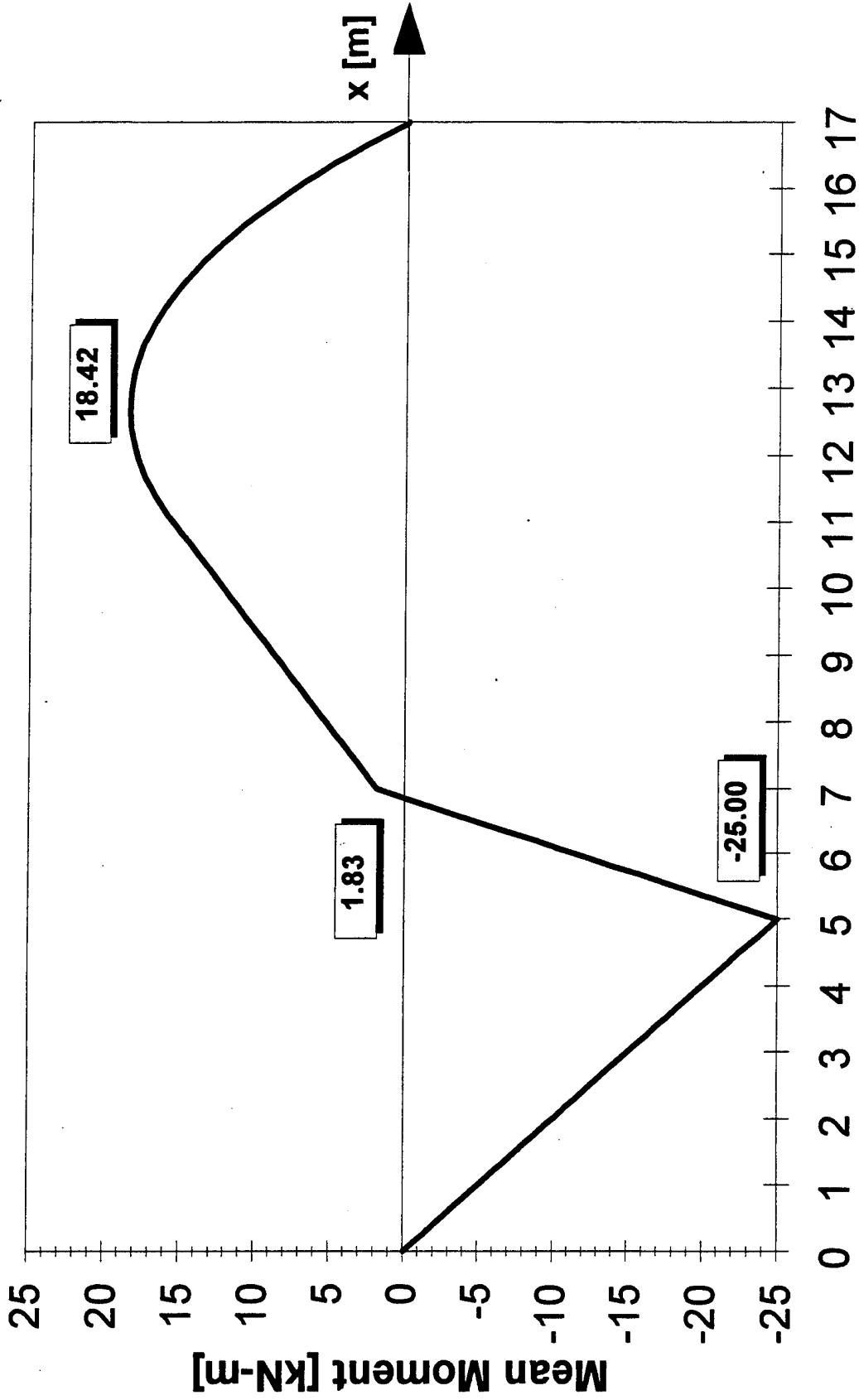

Moment Dispersion Diagram

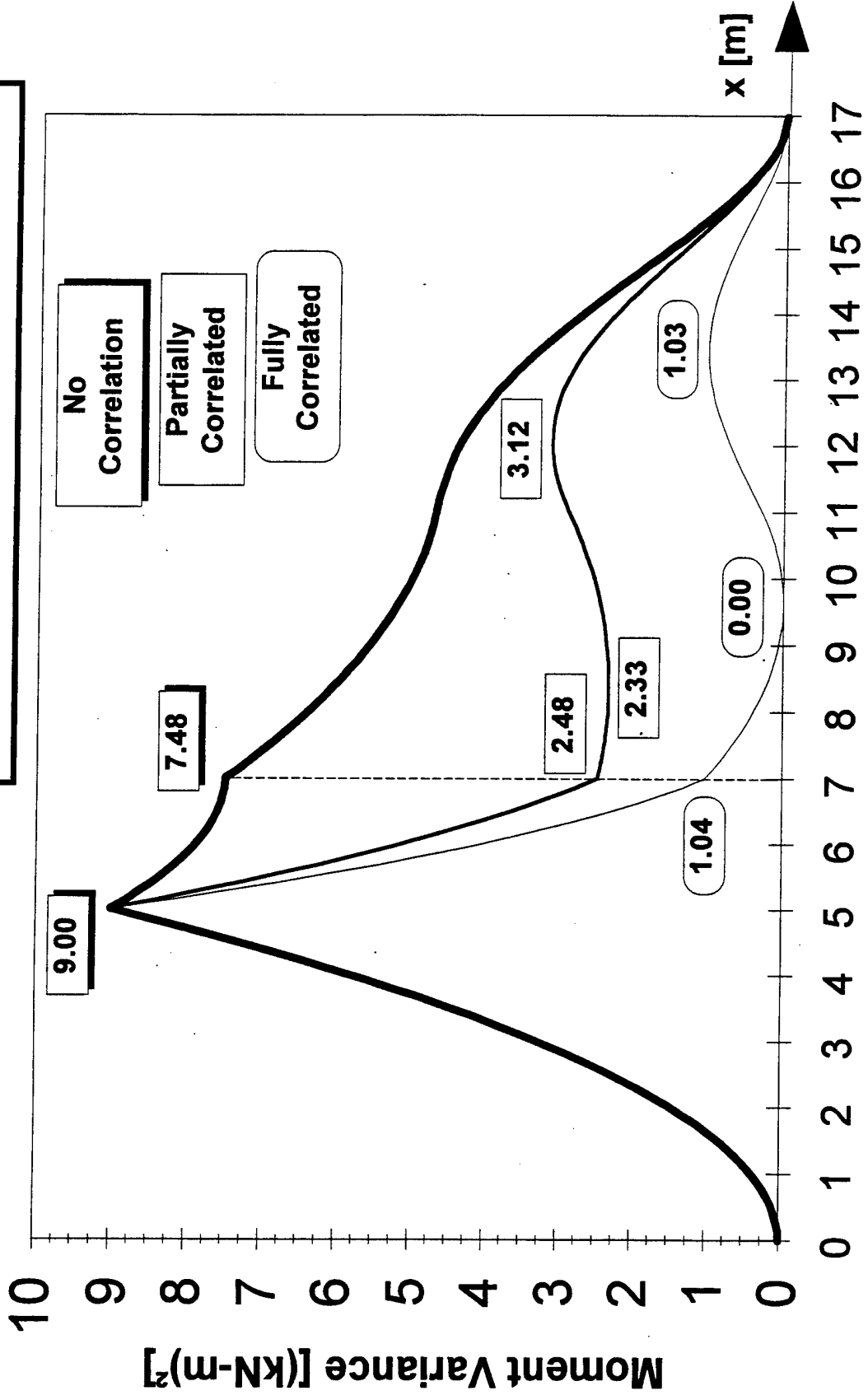

Shear Reliability Diagram

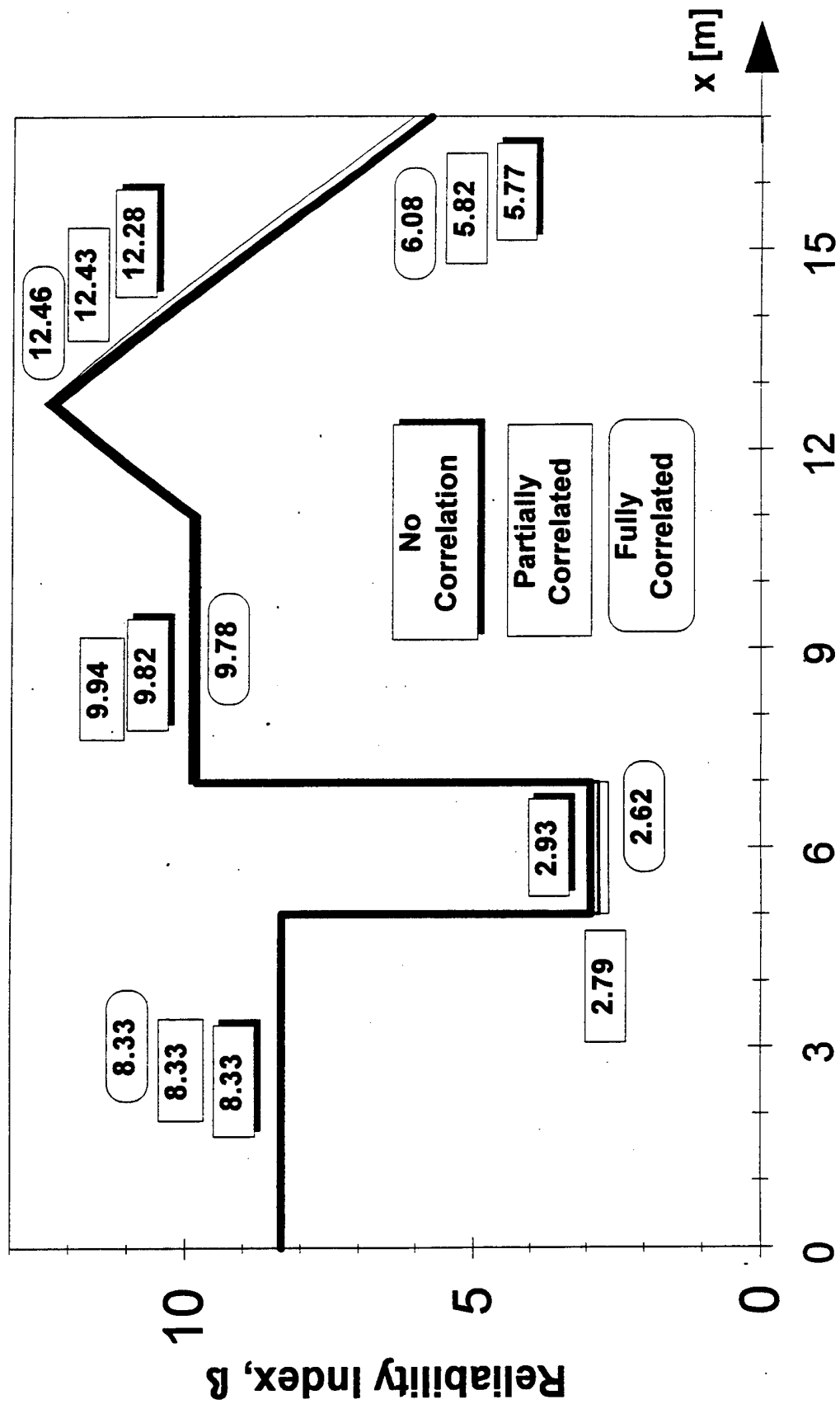

Moment Reliability Diagram

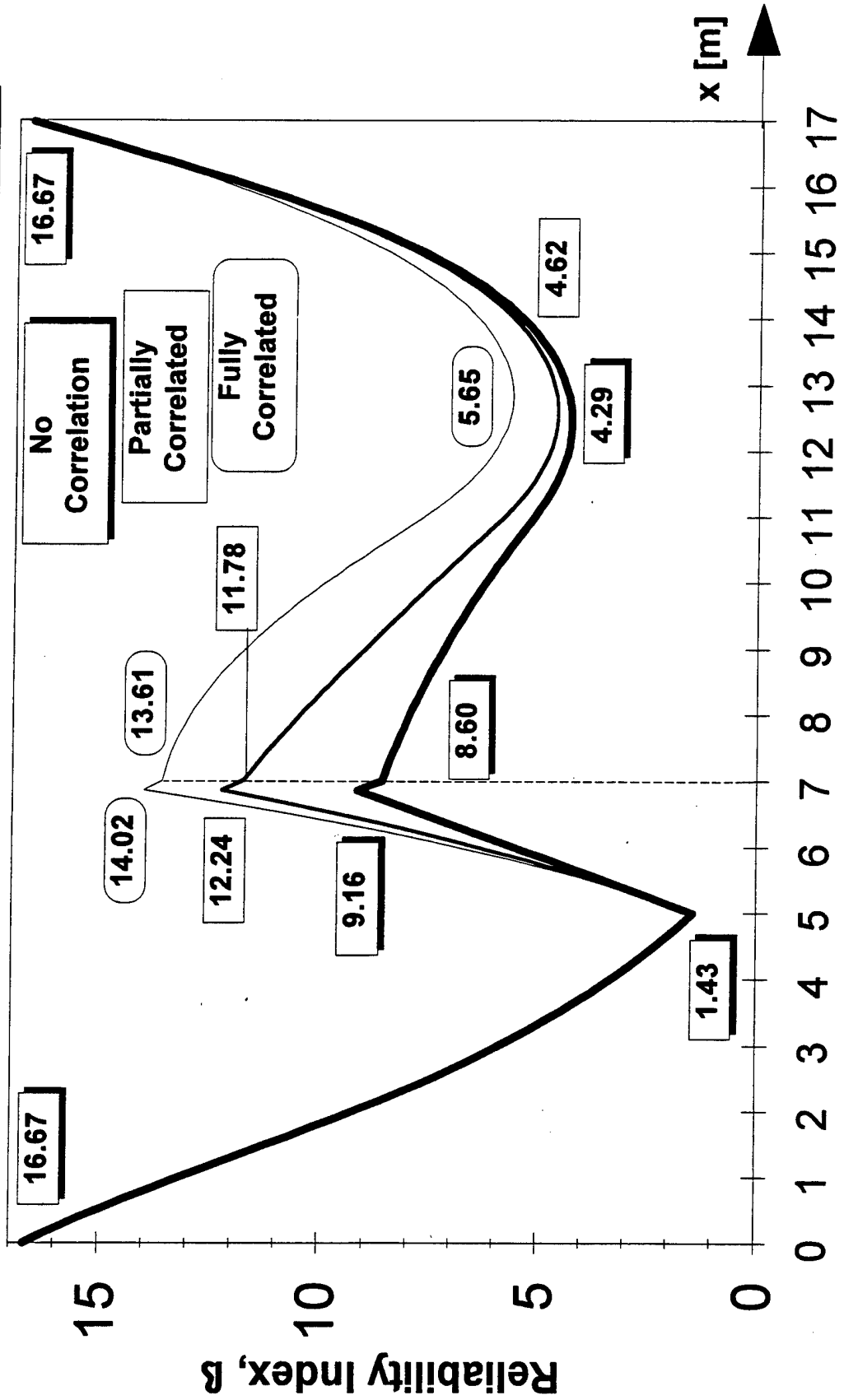

Shear Reliability Diagram

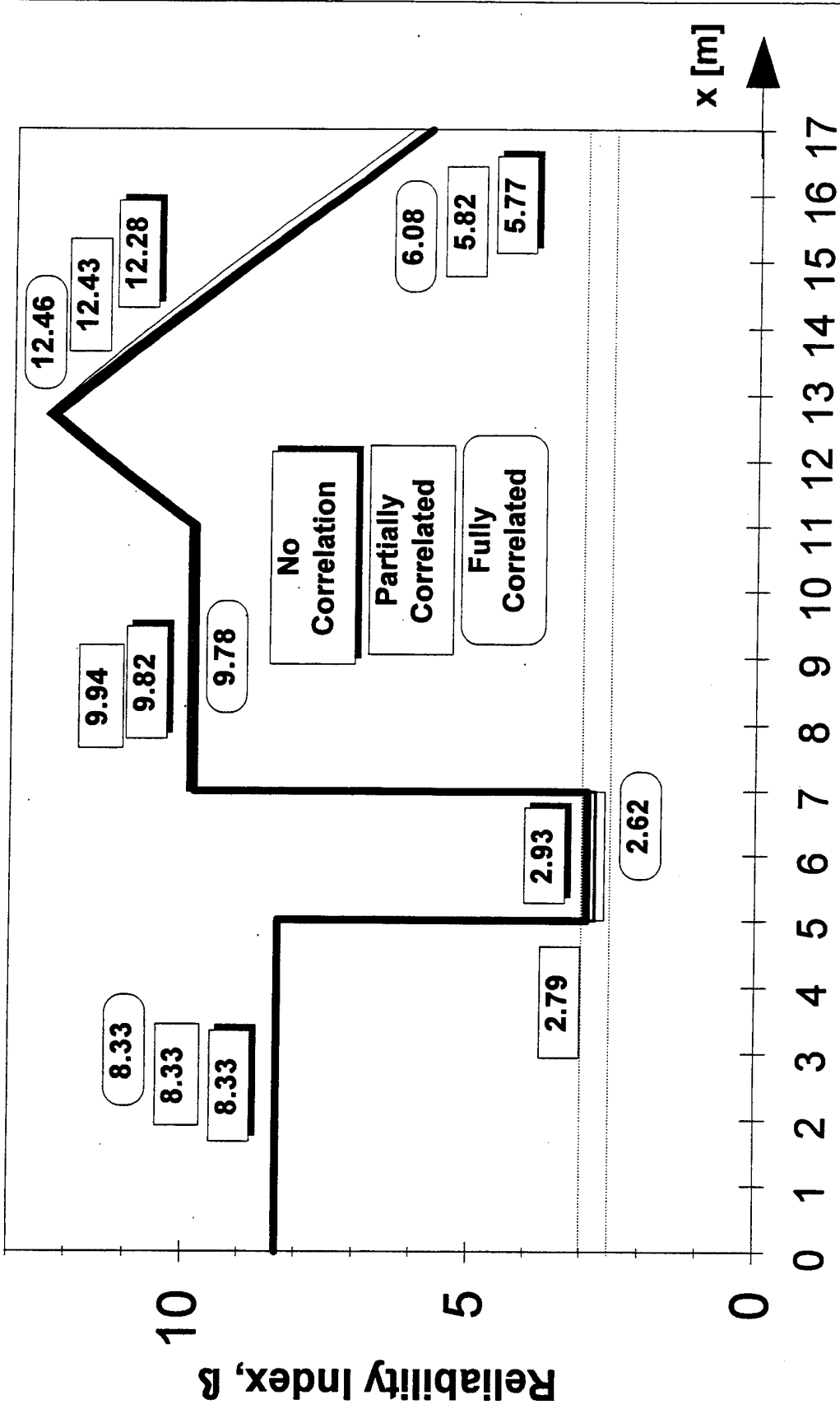

Normal

Shear Reliability Diagram

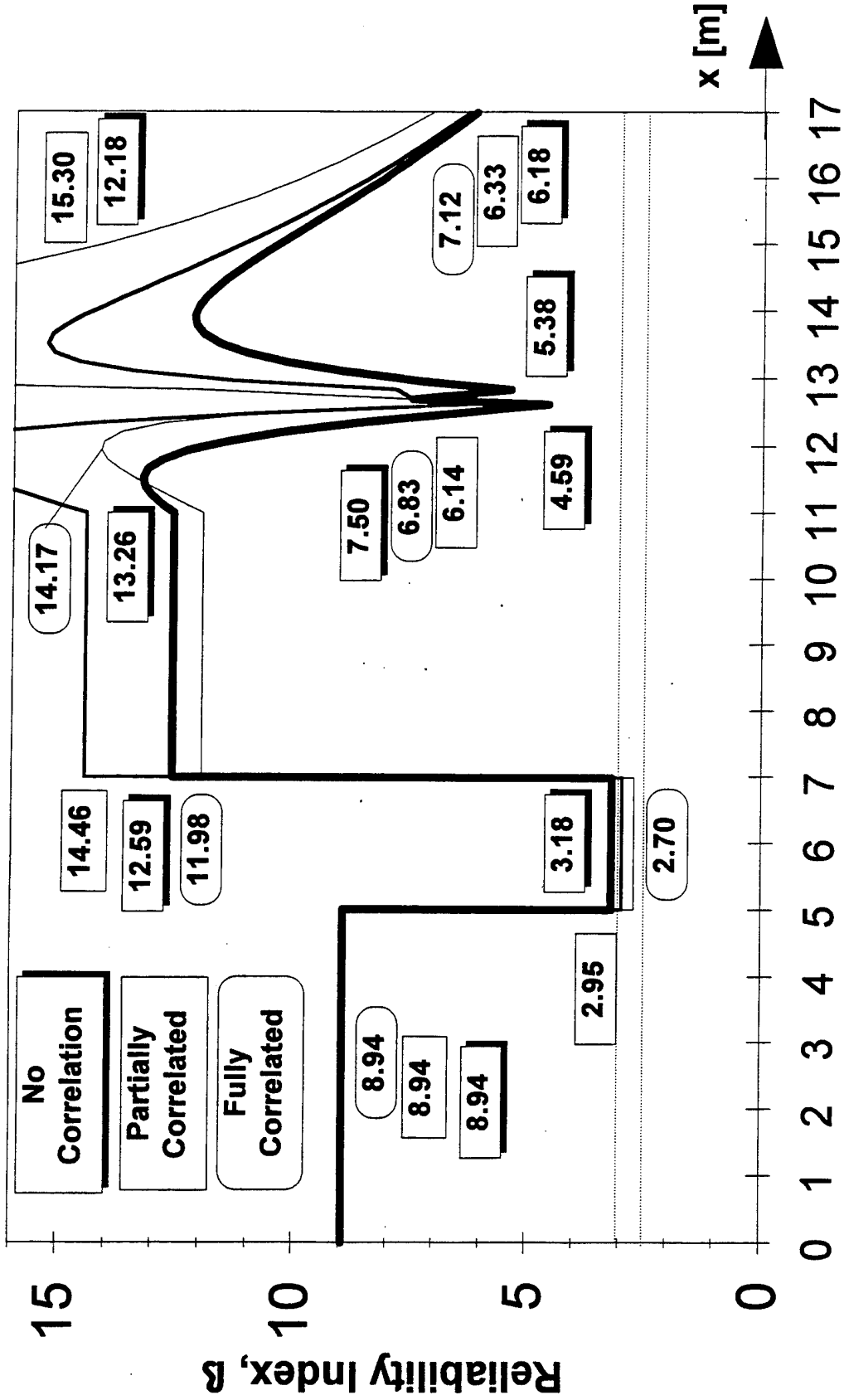

Log-Normal

Shear "Factor of Safety" Diagram

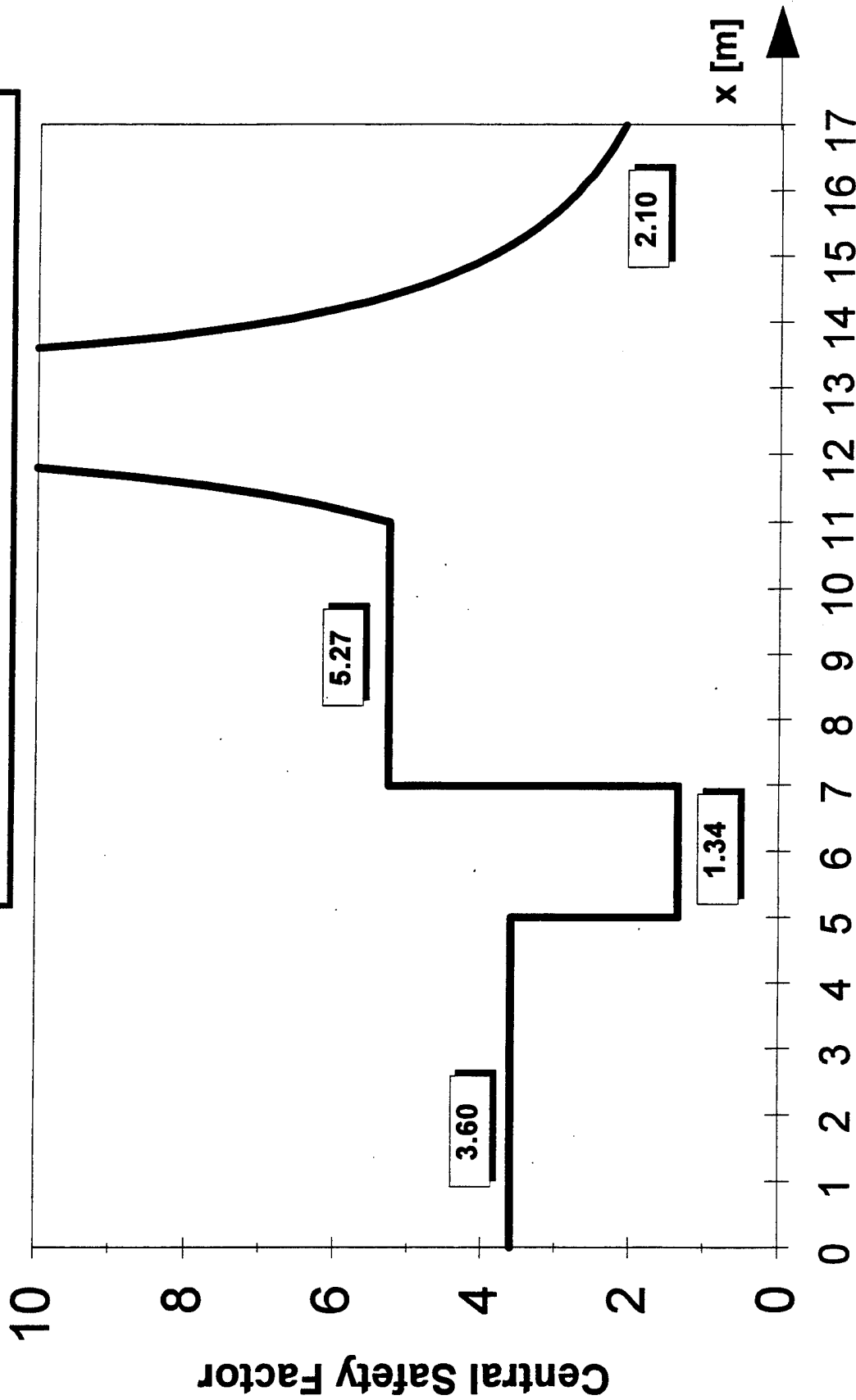

Moment Reliability Diagram

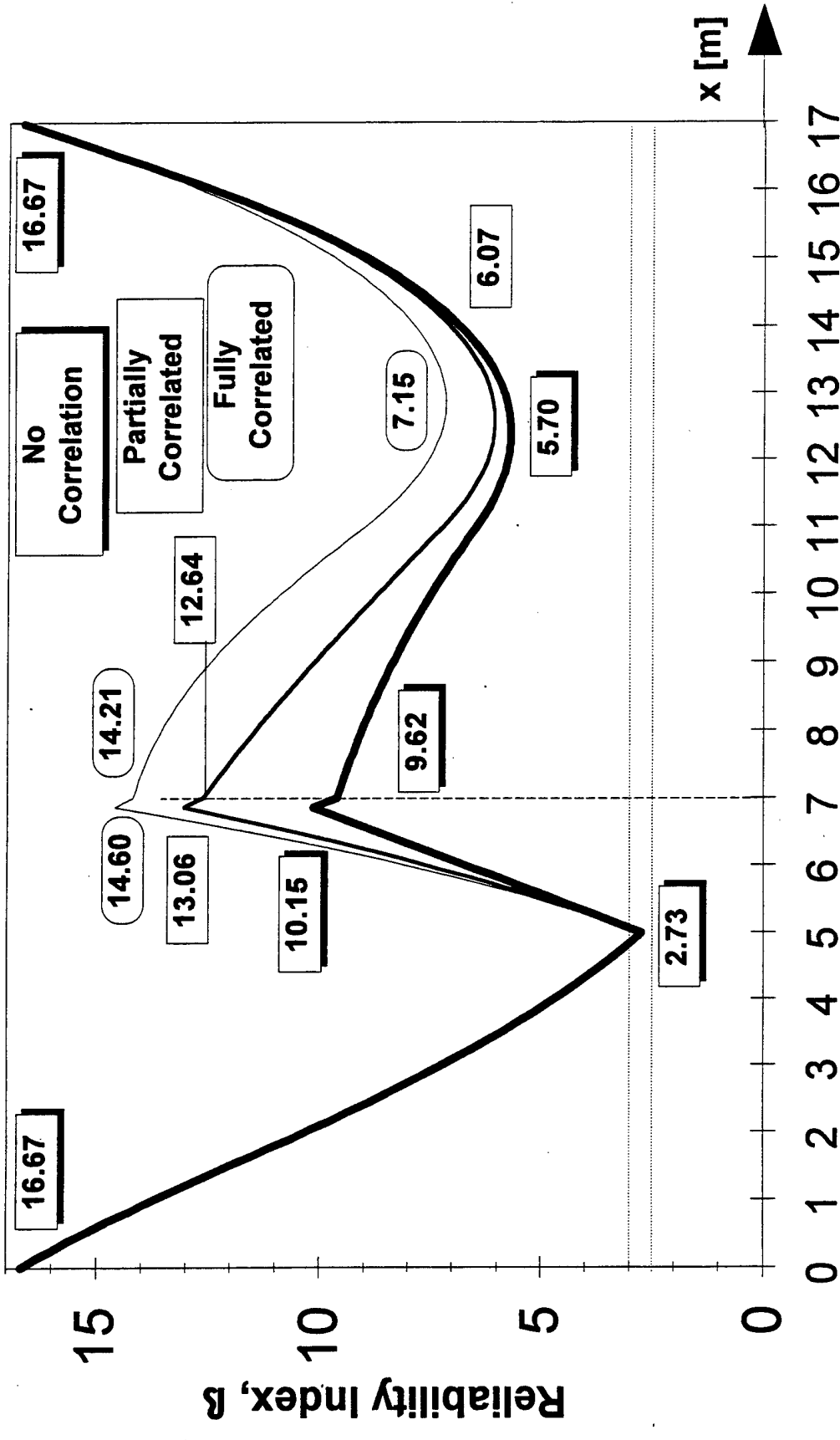

Moment Reliability Diagram

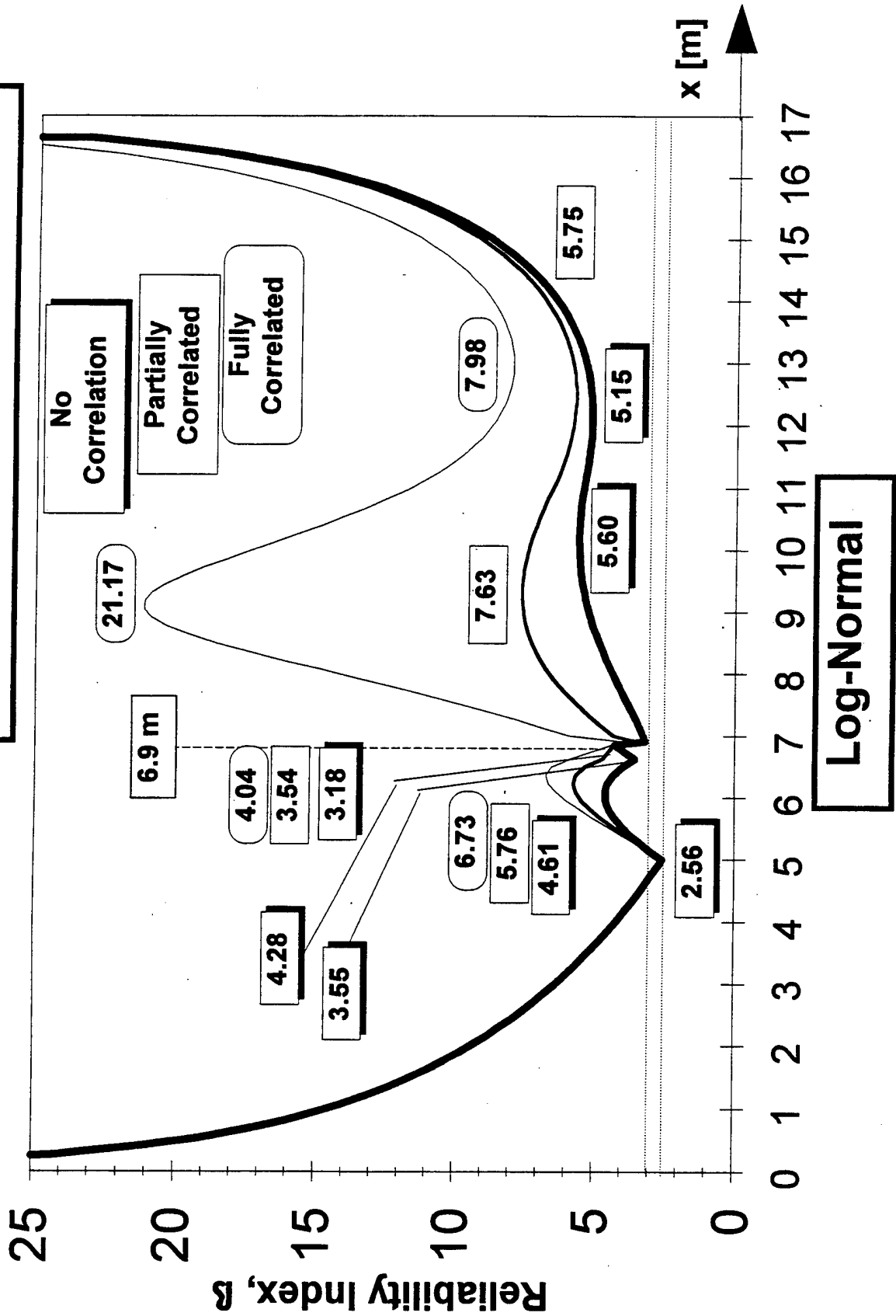

Moment "Factor of Safety" Diagram

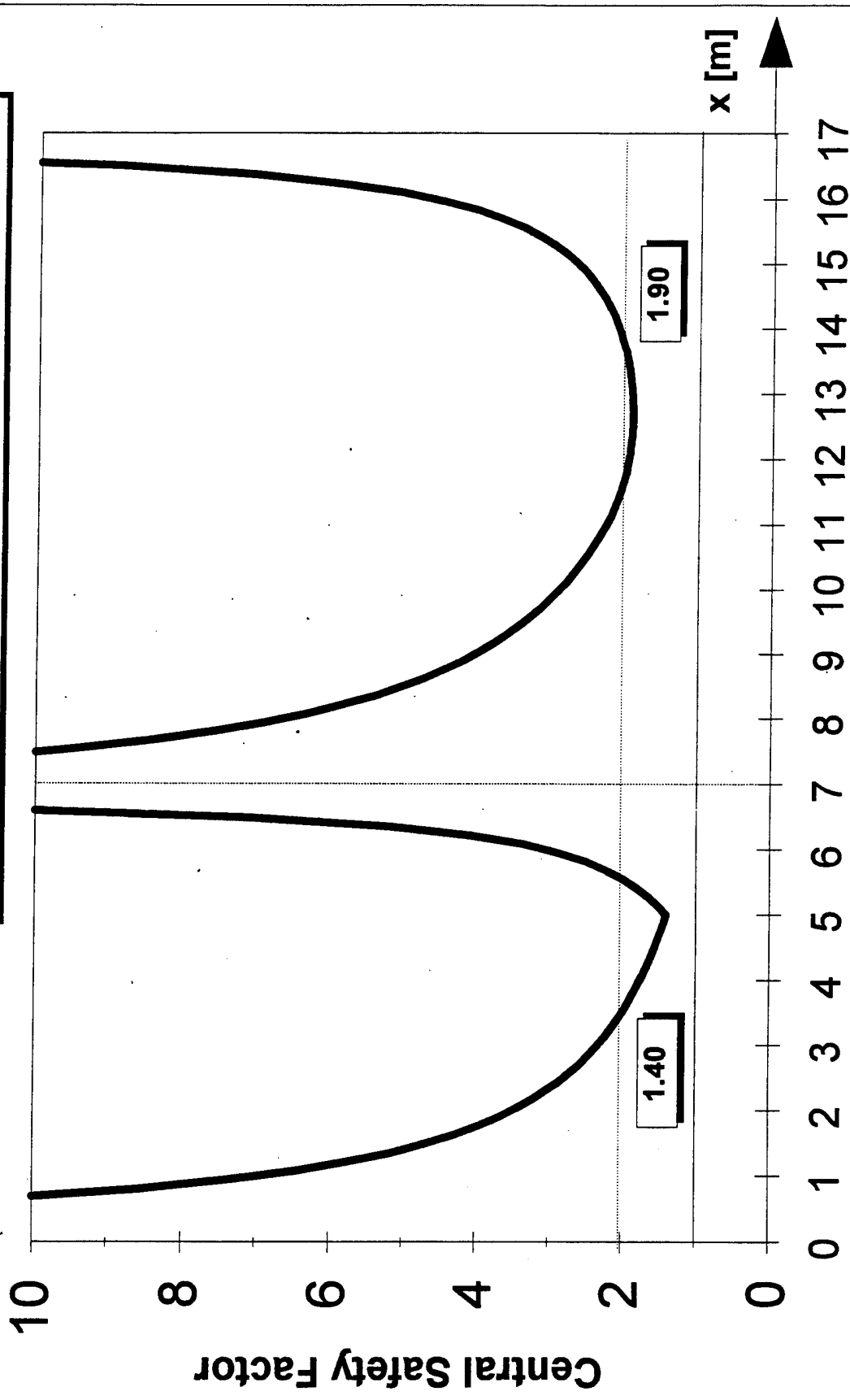

Reliability Index vs Safety Factor in Structures

Appendix B B3

Sample System 3

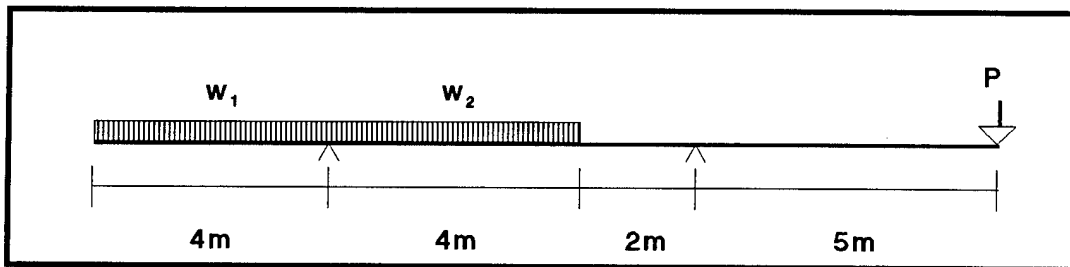

Figure 3.1c *Simply Supported Beam, Double Cantilever (laursen, p. 46, #2-7)*

Contents

- 1-1 Reliability Analysis Step problem statement and minimum β results
- 1-2 Design Step problem statement and minimum β results
- 2 Piecewise equations
- 3 Structural Analysis of Loads Diagrams
- 4 Reliability Analysis Step Reliability and Safety Factor Diagrams
- 5 Design Step Reliability and Safety Factor Diagrams

SAMPLE SYSTEM 3

Simply Supported Beam, Doubly Cantilevered

Three random loads

Two distributed loads, One concentrated load

Assume normal, then log-normal, distribution for load and resistance

Uniform beam

Problem Find location of minimum reliability.

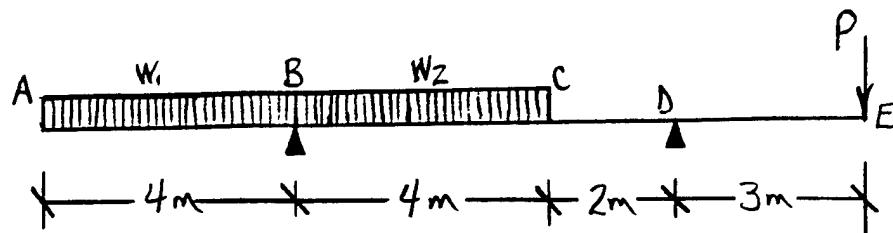

Loading

	Mean		C.O.V.
	(kN)	(KN/m)	
w1	-	2	6%
w2	-	2	12%
P	10	-	10%

Load Correlation

Correlation Coefficients	Case i	Case ii	Case iii
$\rho (w_1, w_2)$	0	1	1
$\rho (w_1, P)$	0	0	1
$\rho (w_2, P)$	0	0	1

Capacity

Shear: $V(R)_{\text{beam}} = 10\%$

Moment: $V(R)_{\text{beam}} = 10\%$

Sample Results

		min β	x (m)	\bar{R}	\bar{S}	V(S)	Correlation
Shear (kN)	N	2.77	10 - 13	15.00	10.00	0.10	any case
	LN	2.87	10 - 13	15.00	10.00	0.10	any case
Moment (kN-m)	N	2.77	10.00	45.00	30.00	0.10	any case
	LN	2.87	10.00	45.00	30.00	0.10	any case

SAMPLE SYSTEM 3

Simply Supported Beam, Doubly Cantilevered

Three random loads

Two distributed loads, One concentrated load

Assume normal, then log-normal, distribution for load and resistance

Uniform beam

Problem (Calibration) Find location of minimum reliability.

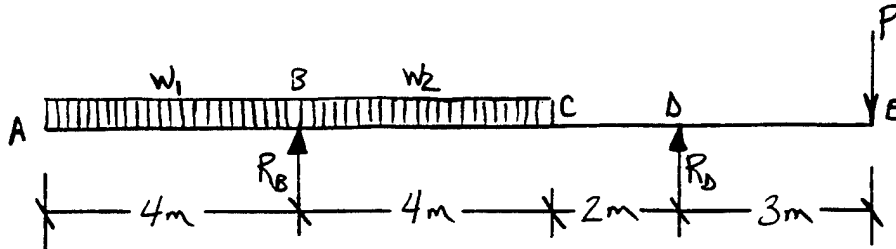

Loading

	Mean		C.O.V.
	(kN)	(kN/m)	
w1	-	2	6%
w2	-	2	12%
P	10	-	10%

Load Correlation

Correlation Coefficients	Case i	Case ii	Case iii
$\rho(w_1, w_2)$	0	1	1
$\rho(w_1, P)$	0	0	1
$\rho(w_2, P)$	0	0	1

Capacity

Shear: $\bar{R} = 20$ kN, $V(R)_{\text{beam}} = 10\%$
Moment: $\bar{R} = 35$ kN-m, $V(R)_{\text{beam}} = 15\%$

Sample Results

		min β	x (m)	\bar{S}	V(S)	Correlation
Shear (kN)	N	4.47	10 - 13	10.00	0.10	Case i
	LN	3.72	5.61	0.21	3.08	Case ii
Moment (kN-m)	N	0.83	10.00	30.00	0.10	any case
	LN	0.83	10.00	30.00	0.10	any case

Beam System 3

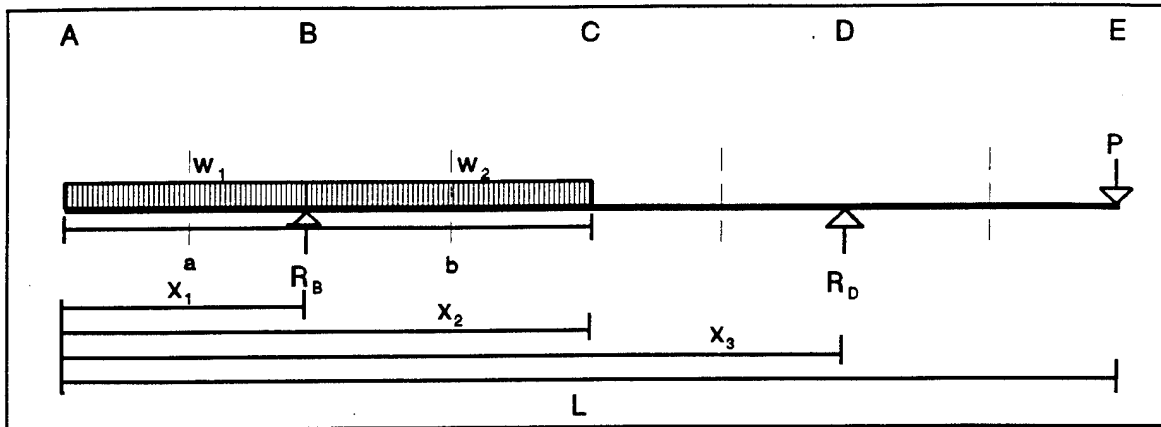

STATICS

Sum of Forces (vertical)

$$\sum F_V = 0$$

$$R_B + R_D = aw_1 + bw_2 + P$$

Sum of Moments (about point D)

$$\sum M_D = 0 \quad - aw_1(x_3 - a/2) + R_B(x_3 - x_1) - bw_2(x_3 - x_1 - b/2) + P(L - x_3)$$

$$R_B = aw_1 \left(\frac{x_3 - a/2}{x_3 - x_1} \right) + bw_2 \left(\frac{x_3 - x_1 - b/2}{x_3 - x_1} \right) - P \left(\frac{L - x_3}{x_3 - x_1} \right)$$

Sum of Moments (about point B)

$$\sum M_B = 0 \quad - aw_1(x_1 - a/2) + bw_2(b/2) - R_D(x_3 - x_1) + P(L - x_1)$$

$$R_D = -aw_1 \left(\frac{x_1 - a/2}{x_3 - x_1} \right) + bw_2 \left(\frac{b/2}{x_3 - x_1} \right) - P \left(\frac{L - x_1}{x_3 - x_1} \right)$$

NOTES: Define--

$$k = aw_1 \left(\frac{x_3 - a/2}{x_3 - x_1} \right), \quad m = bw_2 \left(\frac{x_3 - x_1 - b/2}{x_3 - x_1} \right), \quad q = P \left(\frac{L - x_3}{x_3 - x_1} \right),$$

$$r = -aw_1 \left(\frac{x_1 - a/2}{x_3 - x_1} \right), \quad s = bw_2 \left(\frac{b/2}{x_3 - x_1} \right), \quad t = P \left(\frac{L - x_1}{x_3 - x_1} \right)$$

Segment AB

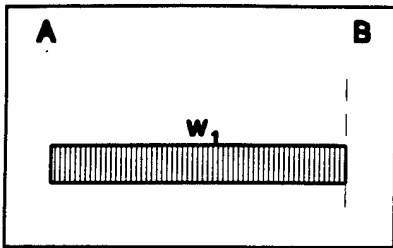

Shear

$$V = -w_1 x$$

Shear Dispersion

$$\sigma_{S_V}^2 = (-x)^2 \sigma_{w_1}^2$$

Moment

$$M = -w_1 \left(\frac{x^2}{2} \right)$$

Moment Dispersion

$$\sigma_{S_M}^2 = \left(\frac{-x^2}{2} \right)^2 \sigma_{w_1}^2$$

Segment BC

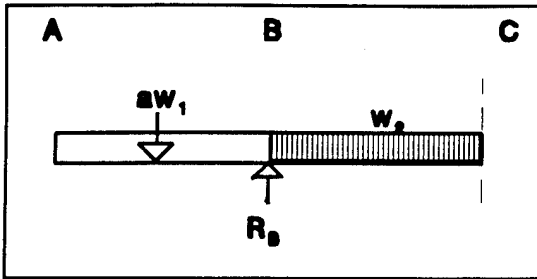

Shear

$$V = -aw_1 + R_B - w_2(x-x_1)$$

$$V = (-a+ak)w_1 + (bm-x+x_1)w_2 - qP$$

Shear Dispersion

$$\begin{aligned} \sigma_{S_V}^2 = & (-a+ak)^2 \sigma_{w_1}^2 + (bm-x+x_1)^2 \sigma_{w_2}^2 + (-q)^2 \sigma_P^2 + 2\rho_{w_1 w_2} (-a+ak)(bm-x+x_1) \sigma_{w_1} \sigma_{w_2} \\ & + 2\rho_{w_1 P} (-a+ak)(-q) \sigma_{w_1} \sigma_P + 2\rho_{w_2 P} (bm-x+x_1)(-q) \sigma_{w_2} \sigma_P \end{aligned}$$

Moment

$$M = -aw_1 \left(x - \frac{a}{2} \right) + R_B(x-x_1) - w_2 \frac{(x-x_1)^2}{2}$$

$$M = \left[-a \left(x - \frac{a}{2} \right) + ak(x-x_1) \right] w_1 + \left[bm(x+x_1) - \frac{(x-x_1)^2}{2} \right] w_2 - [q(x-x_1)]P$$

Moment Dispersion

$$\begin{aligned} \sigma_{S_M}^2 = & \left[-a \left(x - \frac{a}{2} \right) + ak(x-x_1) \right]^2 \sigma_{w_1}^2 + \left[bm(x+x_1) - \frac{(x-x_1)^2}{2} \right]^2 \sigma_{w_2}^2 + [-q(x-x_1)]^2 \sigma_P^2 \\ & + 2\rho_{w_1 w_2} \left[-a \left(x - \frac{a}{2} \right) + ak(x-x_1) \right] \left[bm(x+x_1) - \frac{(x-x_1)^2}{2} \right] \sigma_{w_1} \sigma_{w_2} \\ & + 2\rho_{w_1 P} \left[-a \left(x - \frac{a}{2} \right) + ak(x-x_1) \right] [-q(x-x_1)] \sigma_{w_1} \sigma_P + 2\rho_{w_2 P} \left[bm(x+x_1) - \frac{(x-x_1)^2}{2} \right] [-q(x-x_1)] \sigma_{w_2} \sigma_P \end{aligned}$$

Segment CD

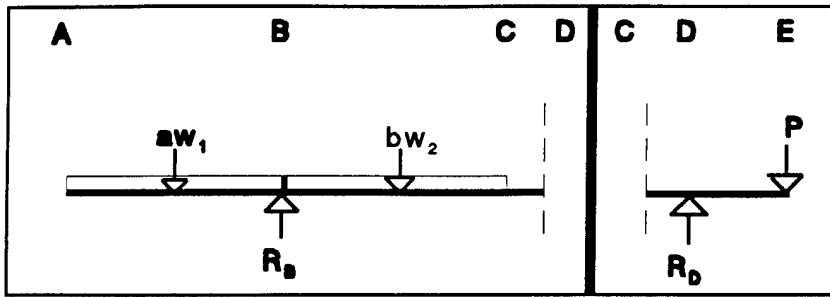

Shear

$$V = -R_D + P$$

$$V = arw_1 - bsw_2 + (1-t)P$$

Shear Dispersion

$$\sigma_{S_V}^2 = (ar)^2 \sigma_{w_1}^2 + (-bs)^2 \sigma_{w_2}^2 + (1-t)^2 \sigma_P^2 + 2\rho_{w_1 w_2} (ar)(bs) \sigma_{w_1} \sigma_{w_2}$$

$$+ 2\rho_{w_1 P} (ar)(1-t) \sigma_{w_1} \sigma_P + 2\rho_{w_2 P} (-bs)(1-t) \sigma_{w_2} \sigma_P$$

Moment

$$M = -P(L-x) + R_D(x_3-x)$$

$$M = [ar(x-x_3)]w_1 + [bs(x_3-x)]w_2 + [tx_3 - L + x - tx]P$$

Moment Dispersion

$$\sigma_{S_M}^2 = [ar(x-x_3)]^2 \sigma_{w_1}^2 + [bs(x_3-x)]^2 \sigma_{w_2}^2 + [tx_3 - L + x - tx]^2 \sigma_P^2$$

$$+ 2\rho_{w_1 w_2} [ar(x-x_3)][bs(x_3-x)] \sigma_{w_1} \sigma_{w_2}$$

$$+ 2\rho_{w_1 P} [ar(x-x_3)][tx_3 - L + x - tx] \sigma_{w_1} \sigma_P + 2\rho_{w_2 P} [bs(x_3-x)][tx_3 - L + x - tx] \sigma_{w_2} \sigma_P$$

Segment DE

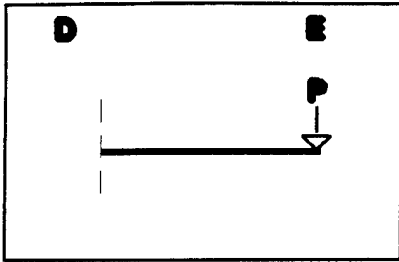

Shear

$$V = P$$

Shear Dispersion

$$\sigma_{S_V}^2 = \sigma_P^2$$

Moment

$$M = (L-x)P$$

Moment Dispersion

$$\sigma_{S_M}^2 = (L-x)^2 \sigma_P^2$$

Shear Diagram

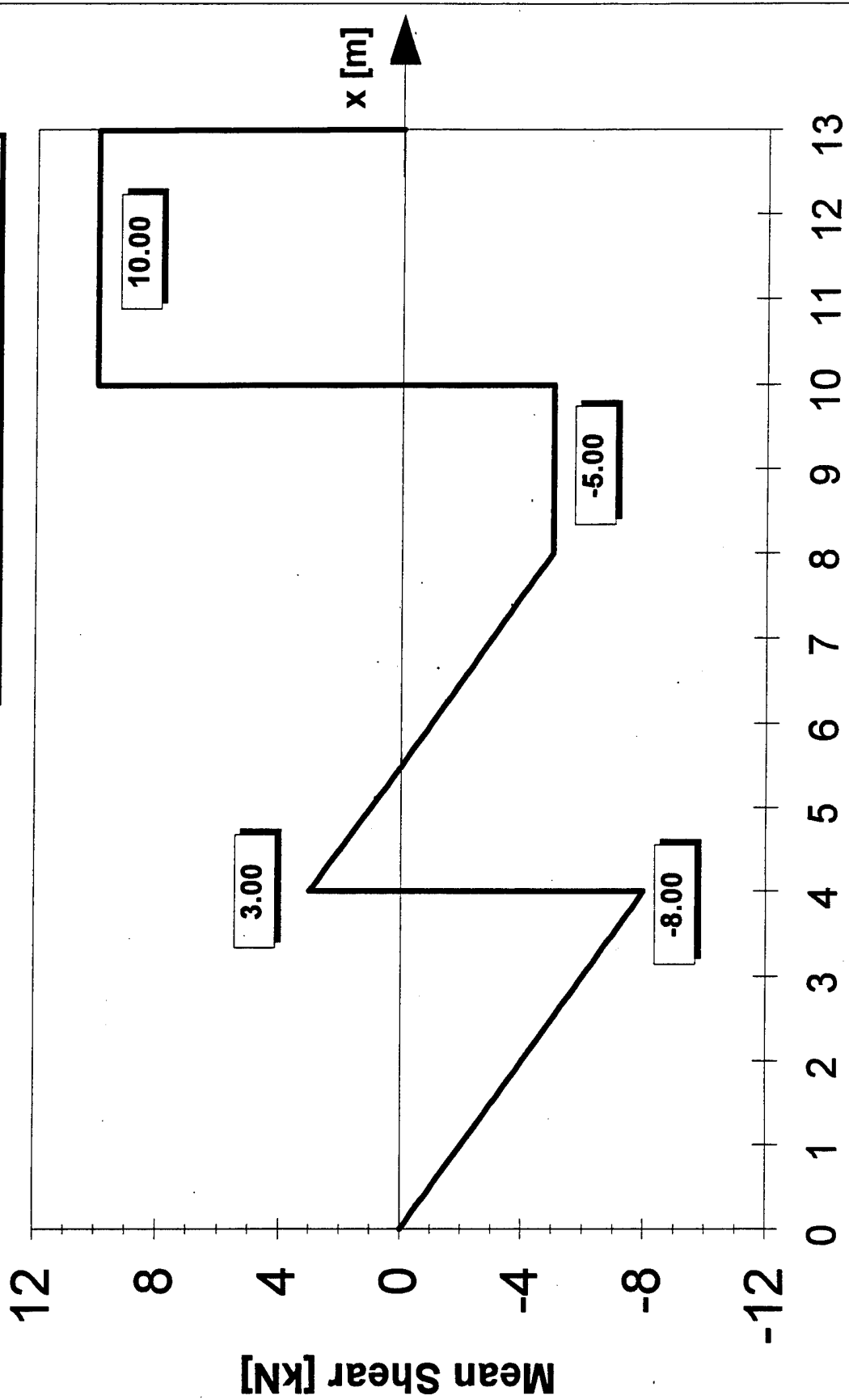

Shear Dispersion Diagram

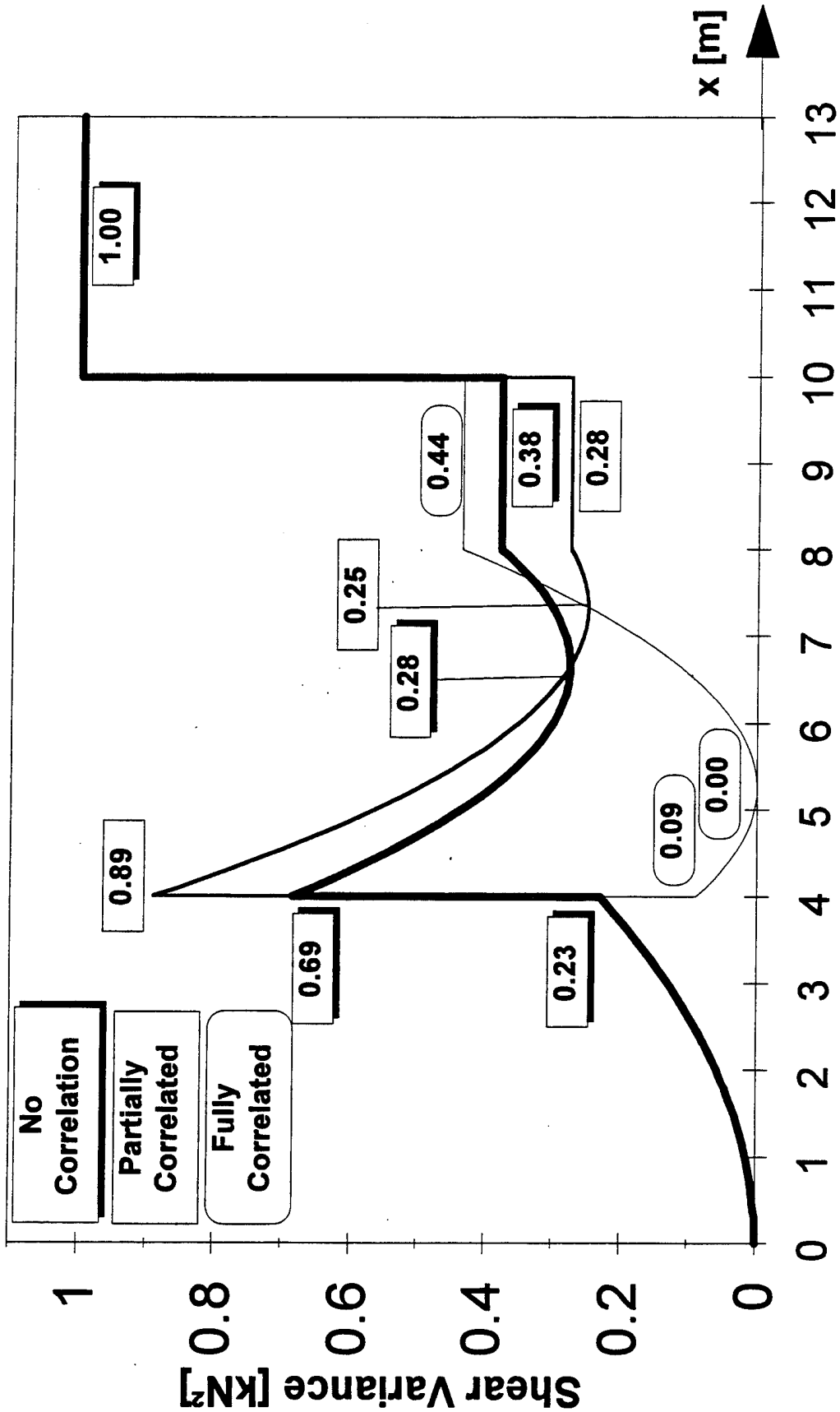

Moment Diagram

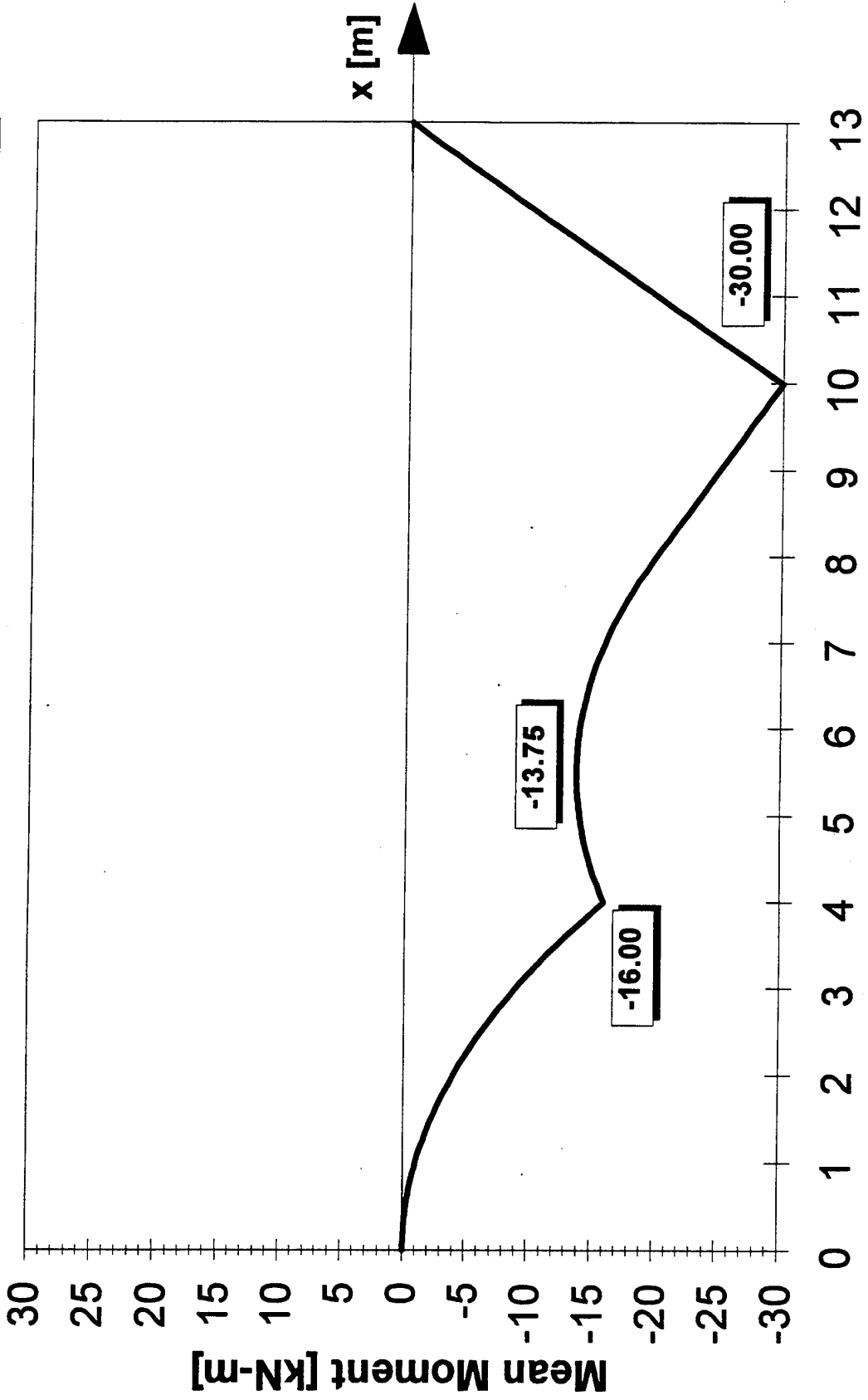

Moment Dispersion Diagram

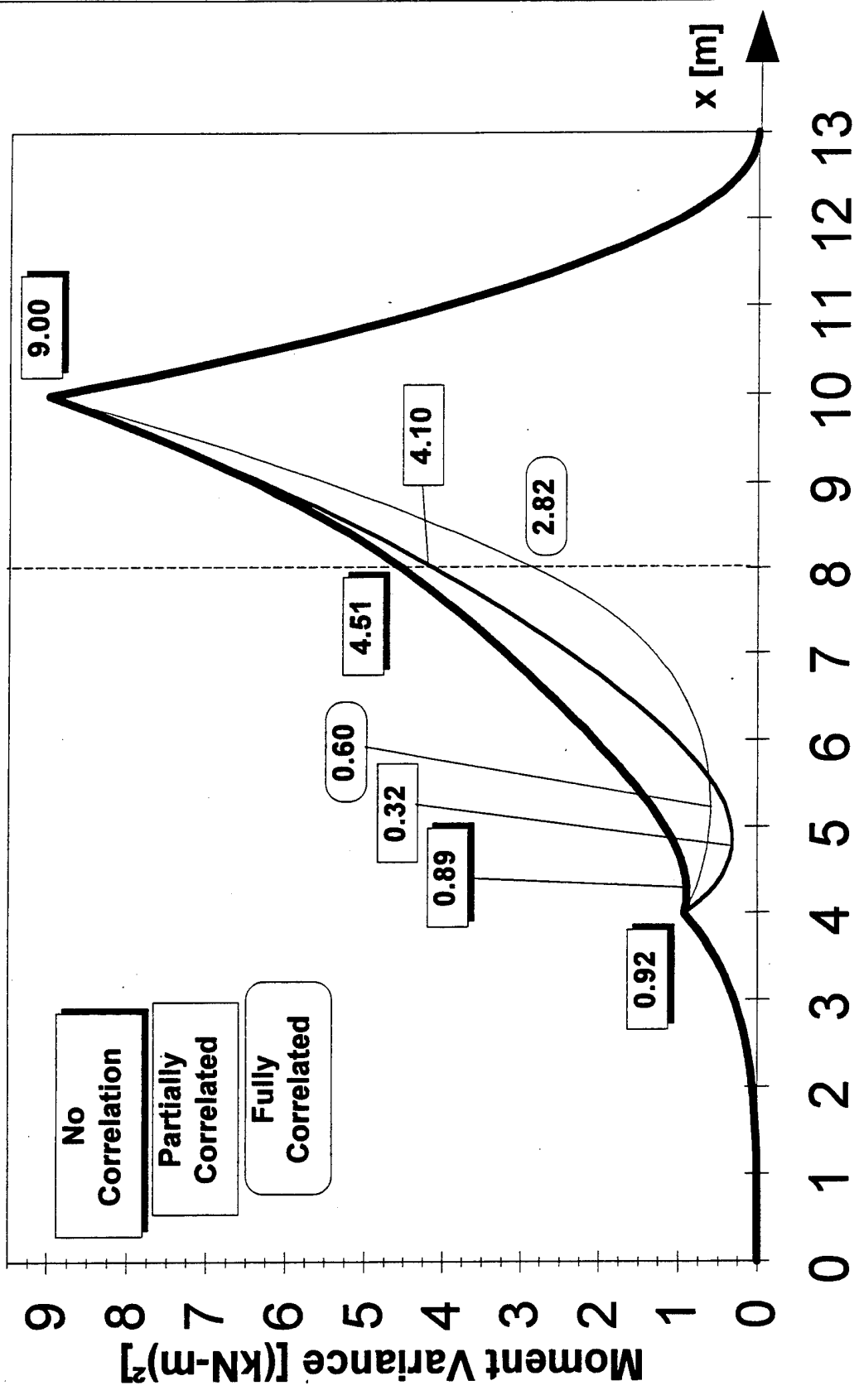

Shear Reliability Diagram

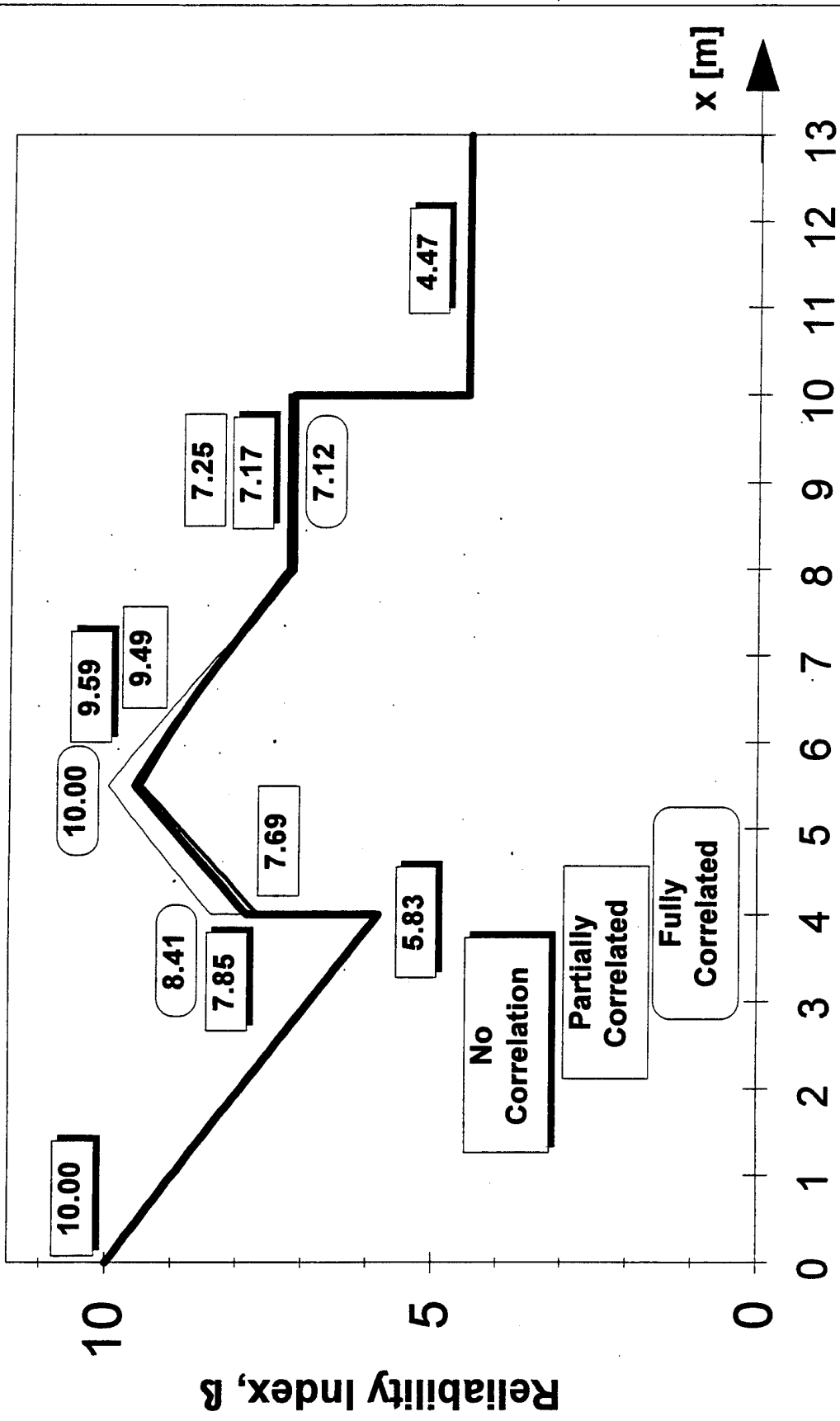

Shear Reliability Diagram

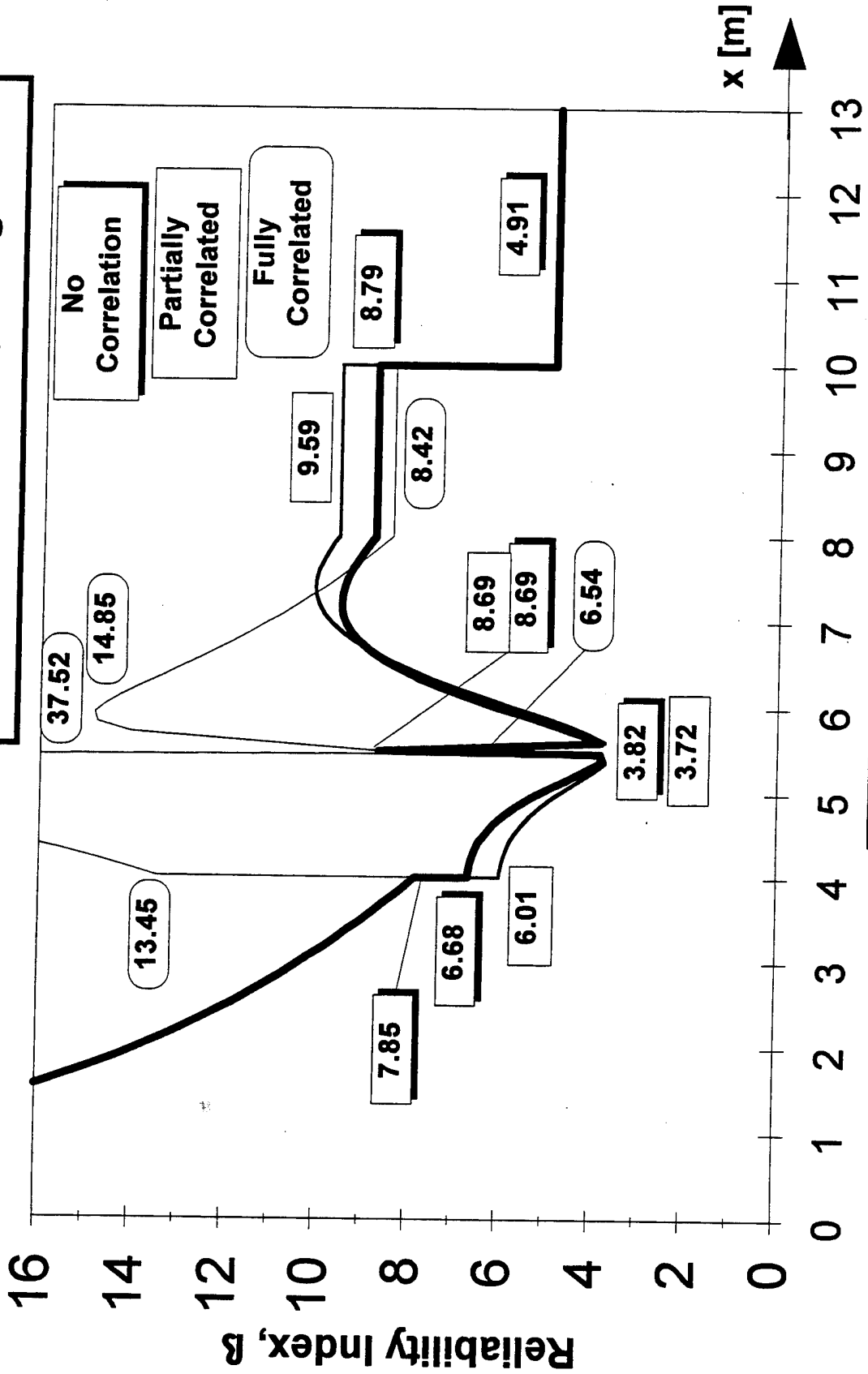

Log-Normal

Shear "Factor of Safety" Diagram

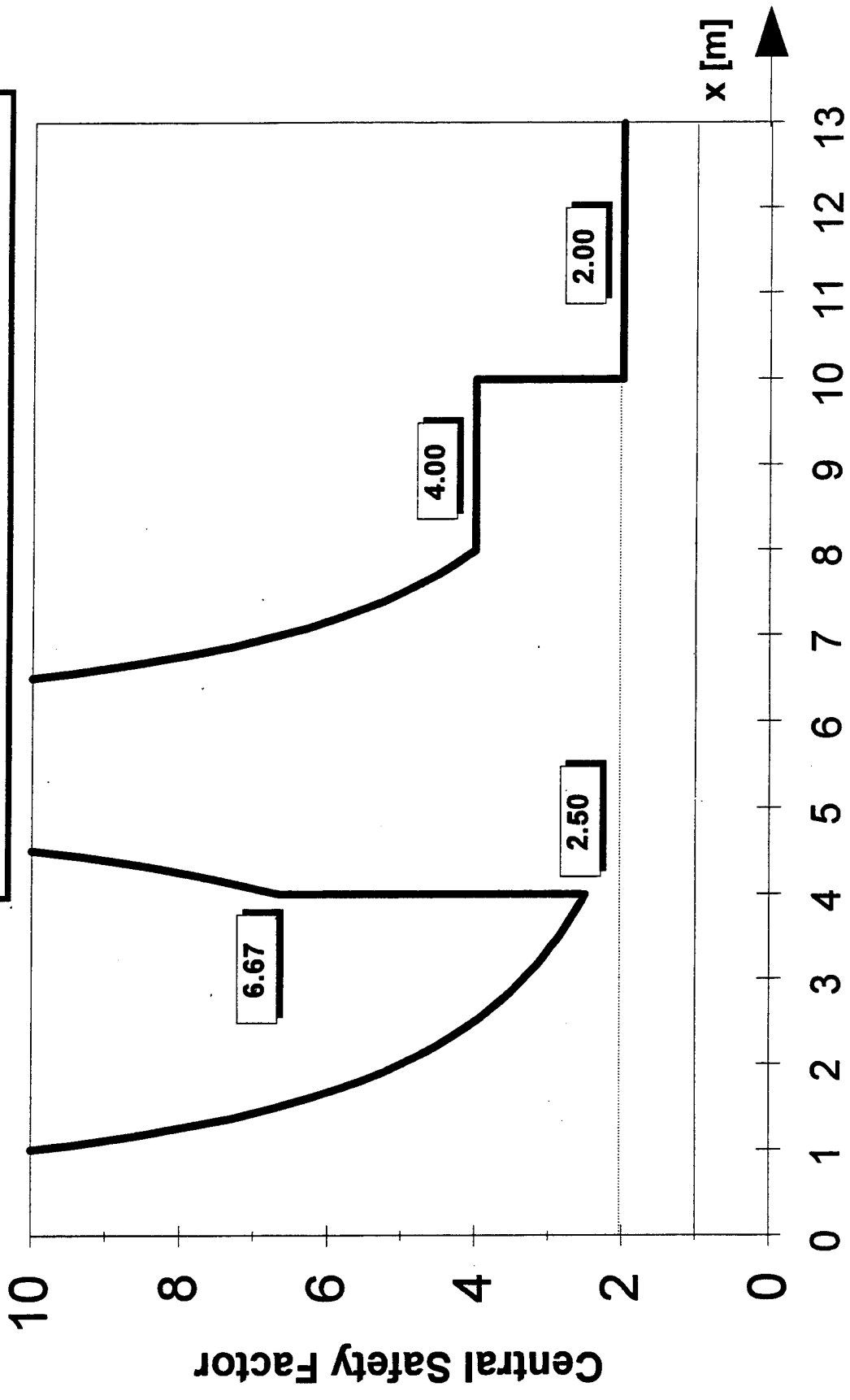

Moment Reliability Diagram

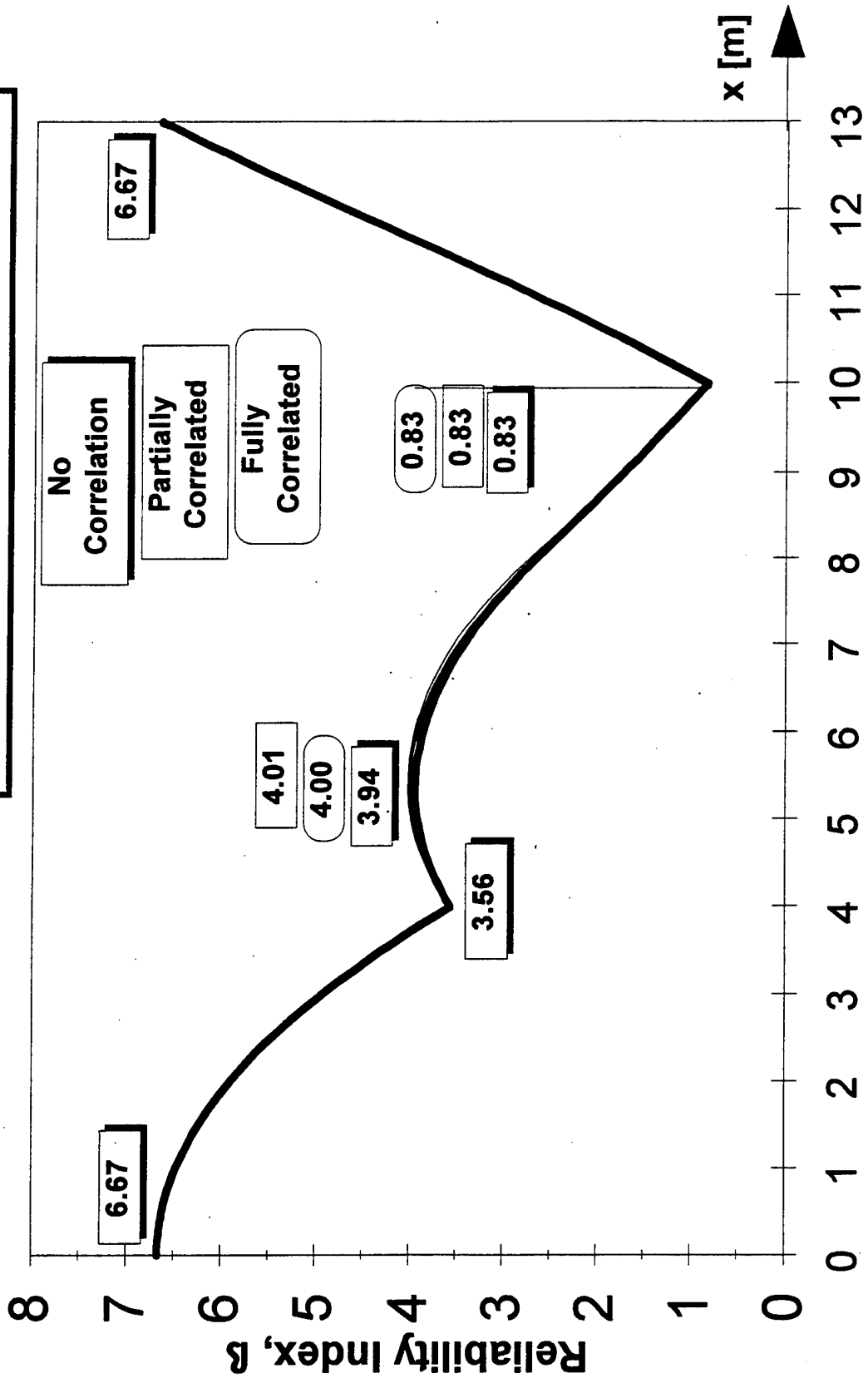

Normal

Moment Reliability Diagram

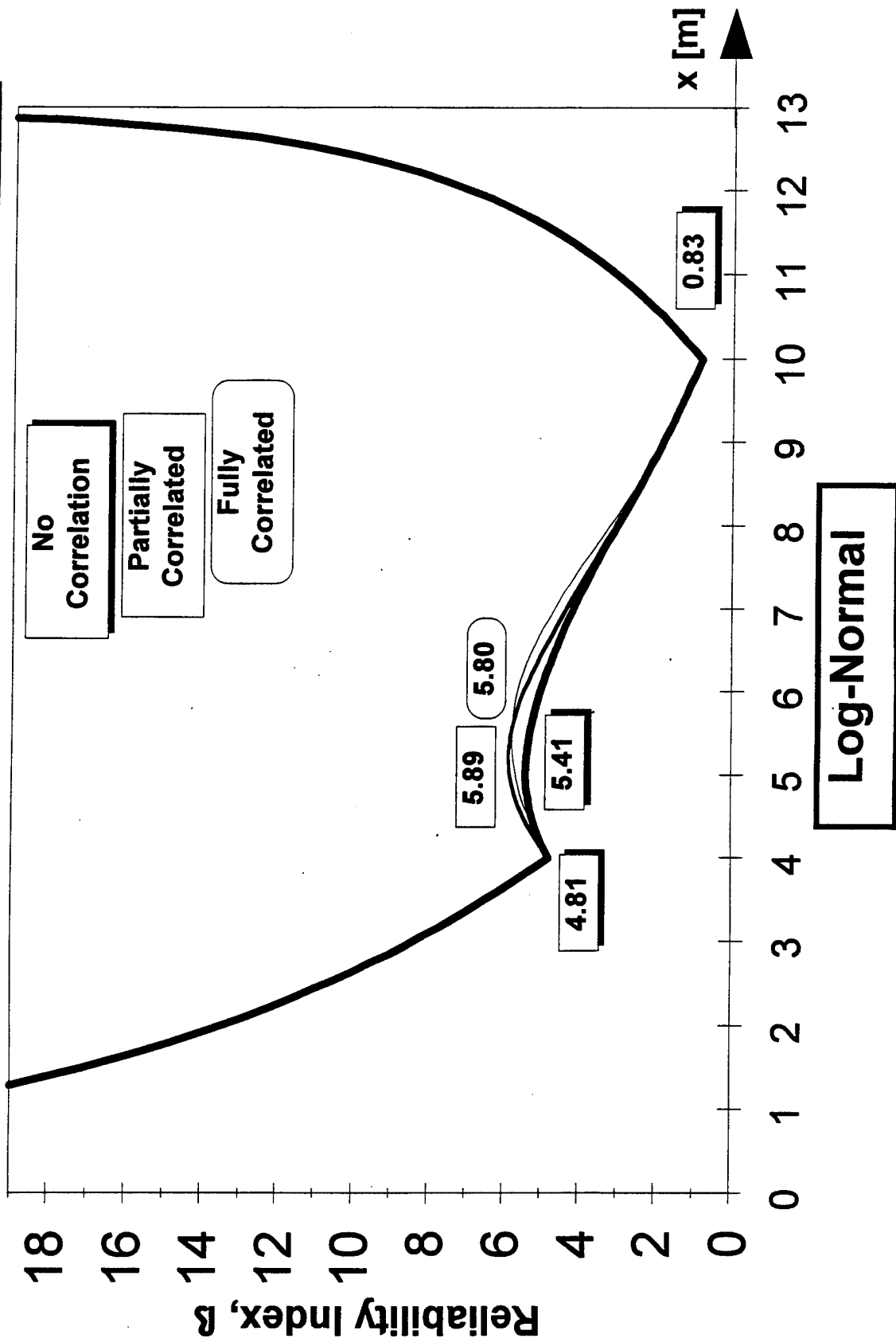

Moment "Factor of Safety" Diagram

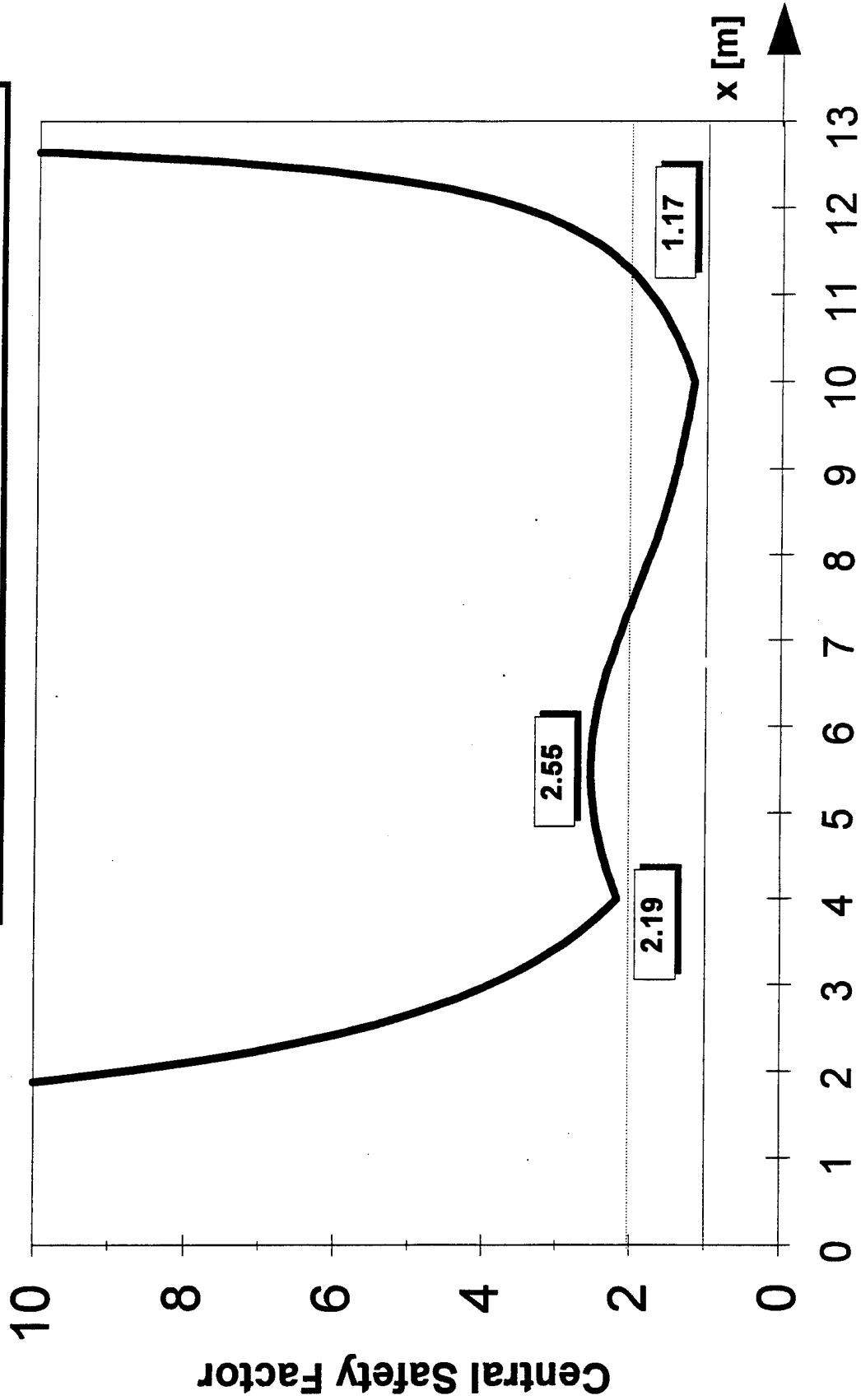

Shear Reliability Diagram

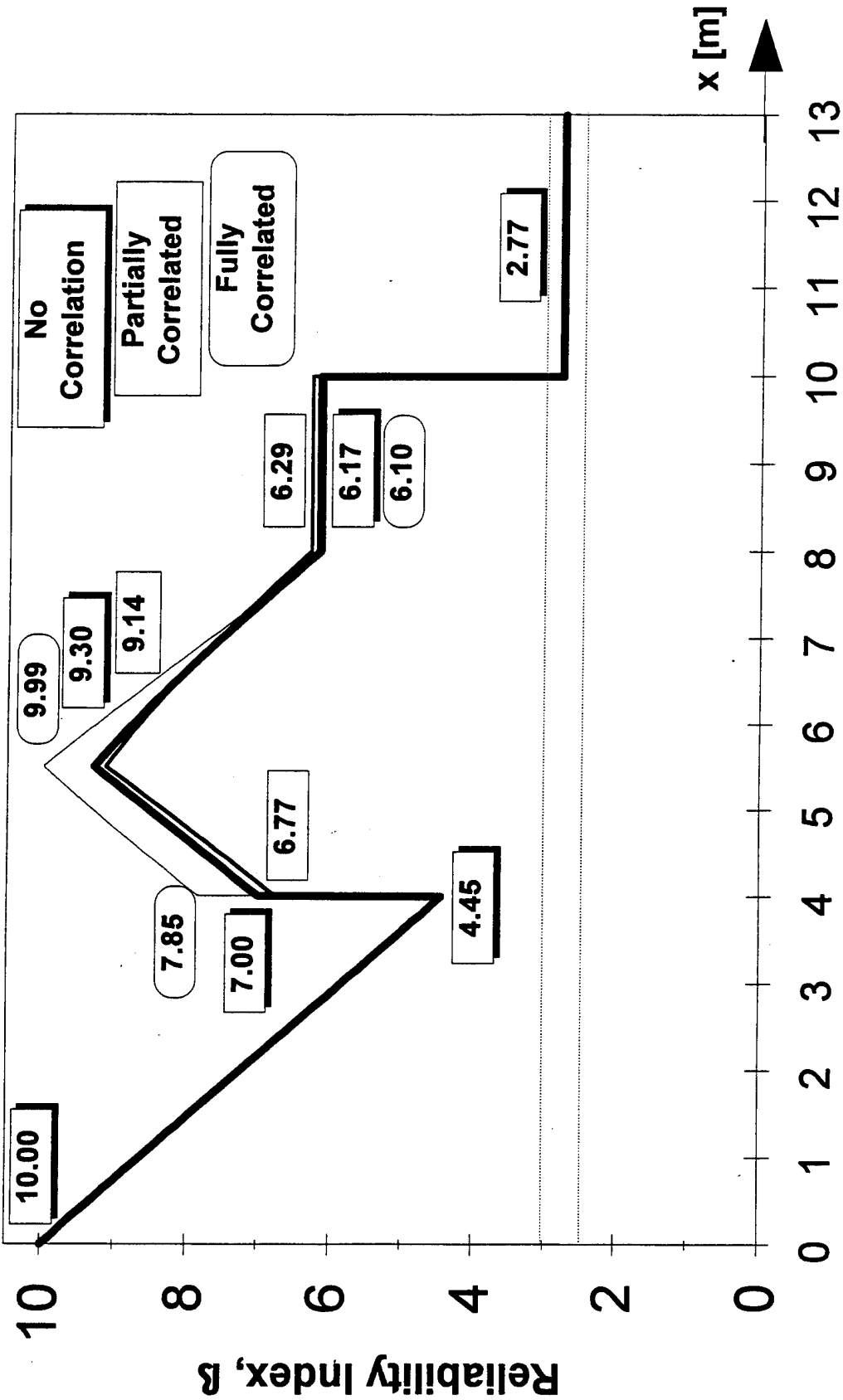

Normal

Shear Reliability Diagram

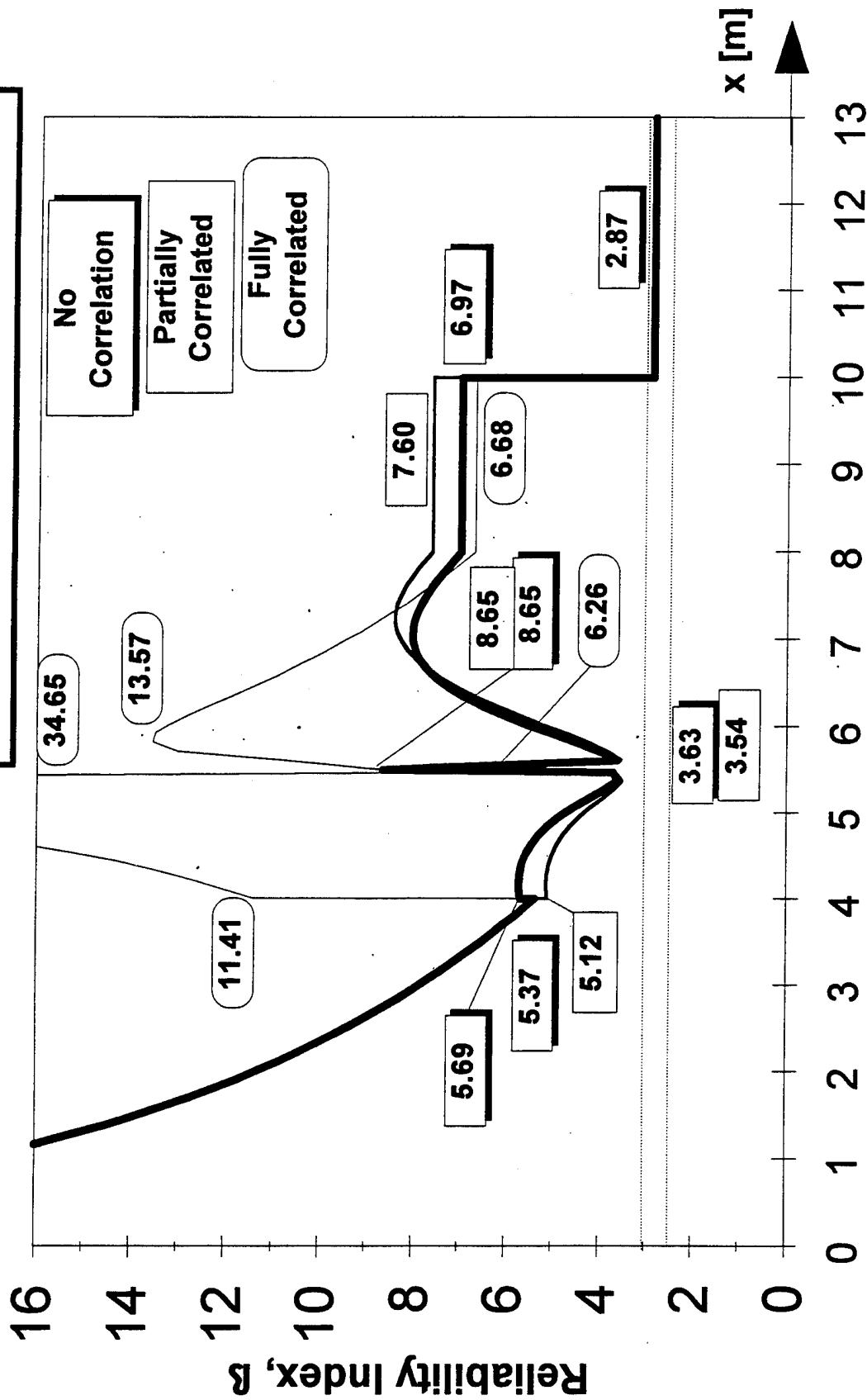

Log-Normal

Shear "Factor of Safety" Diagram

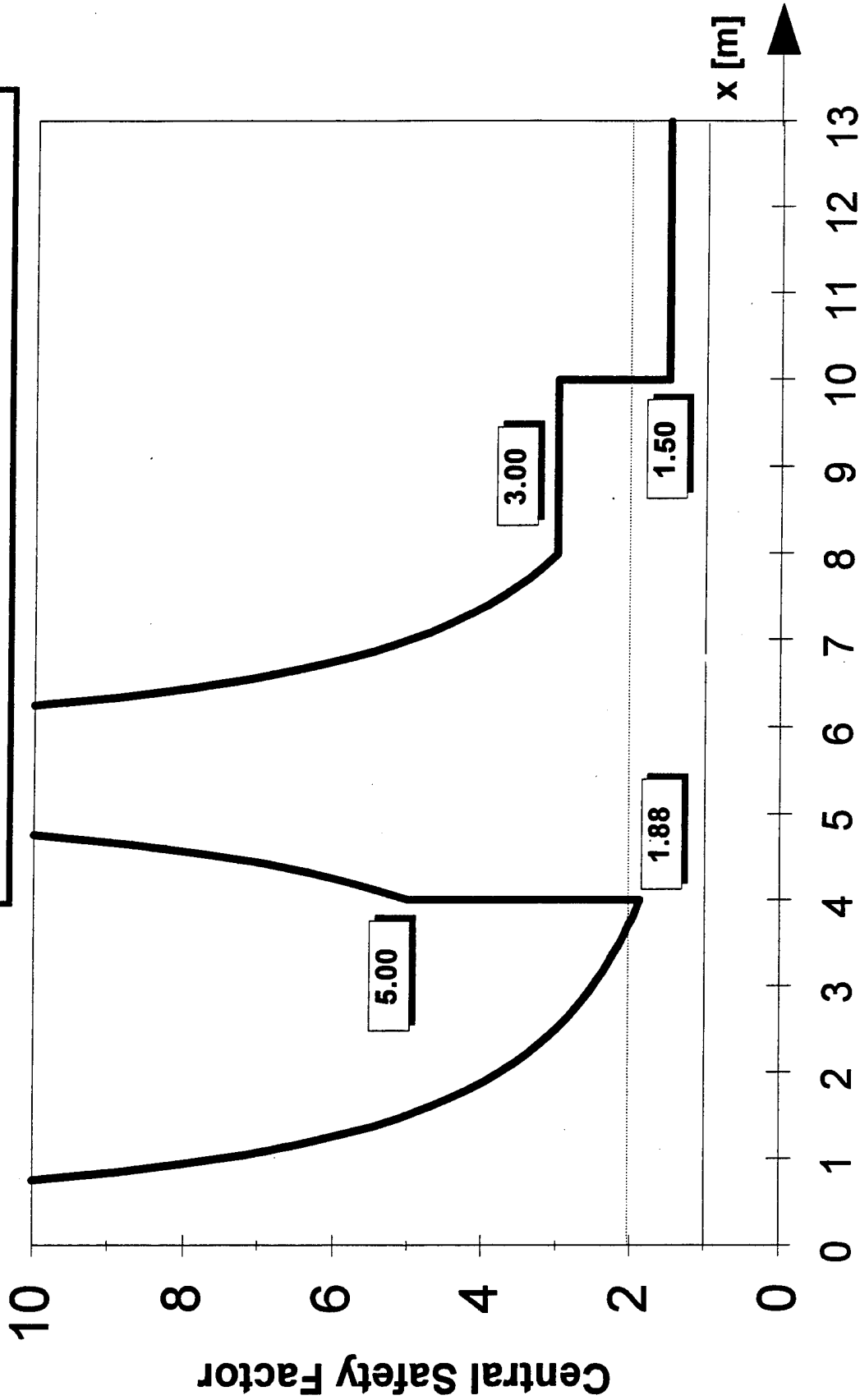

Moment Reliability Diagram

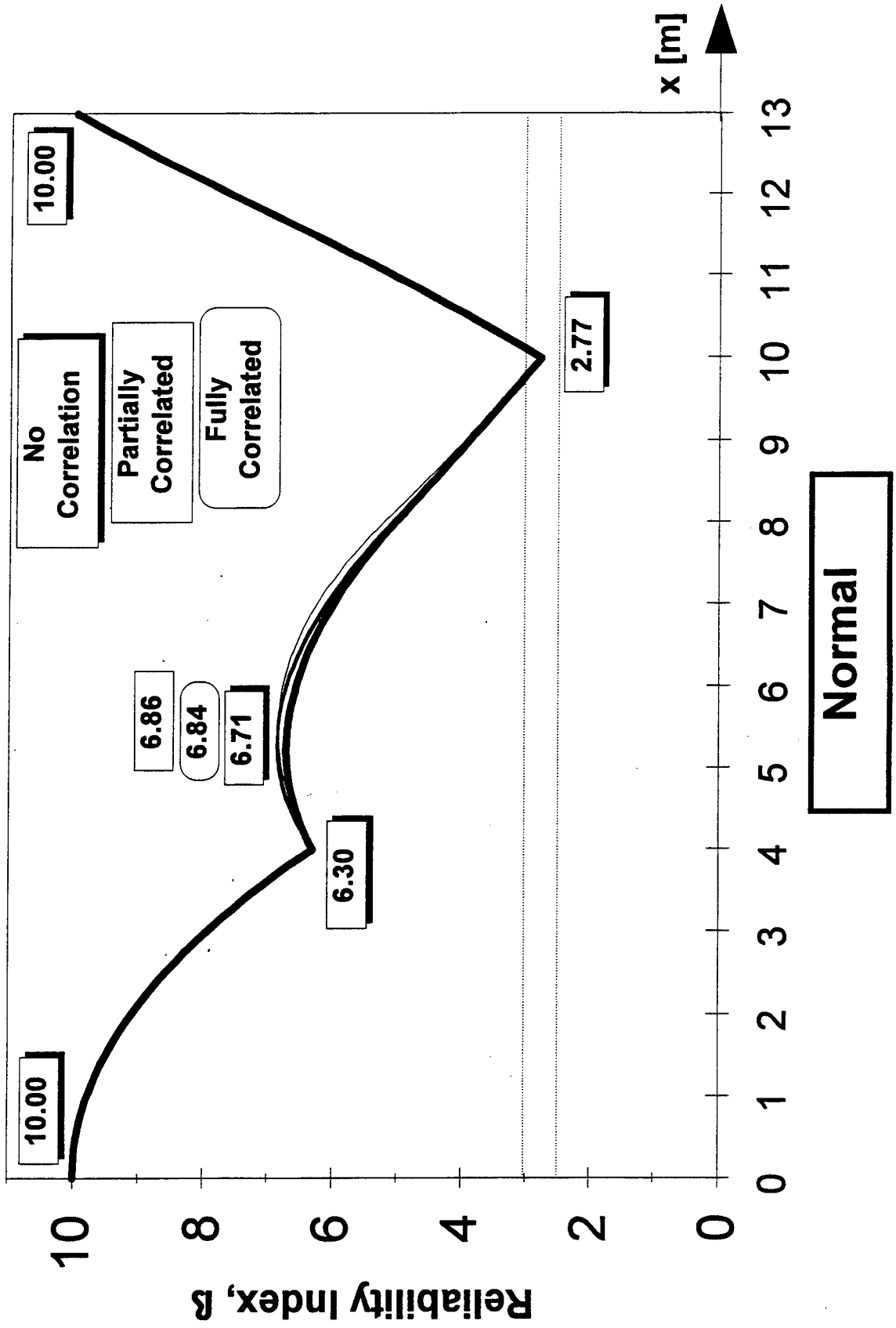

Moment Reliability Diagram

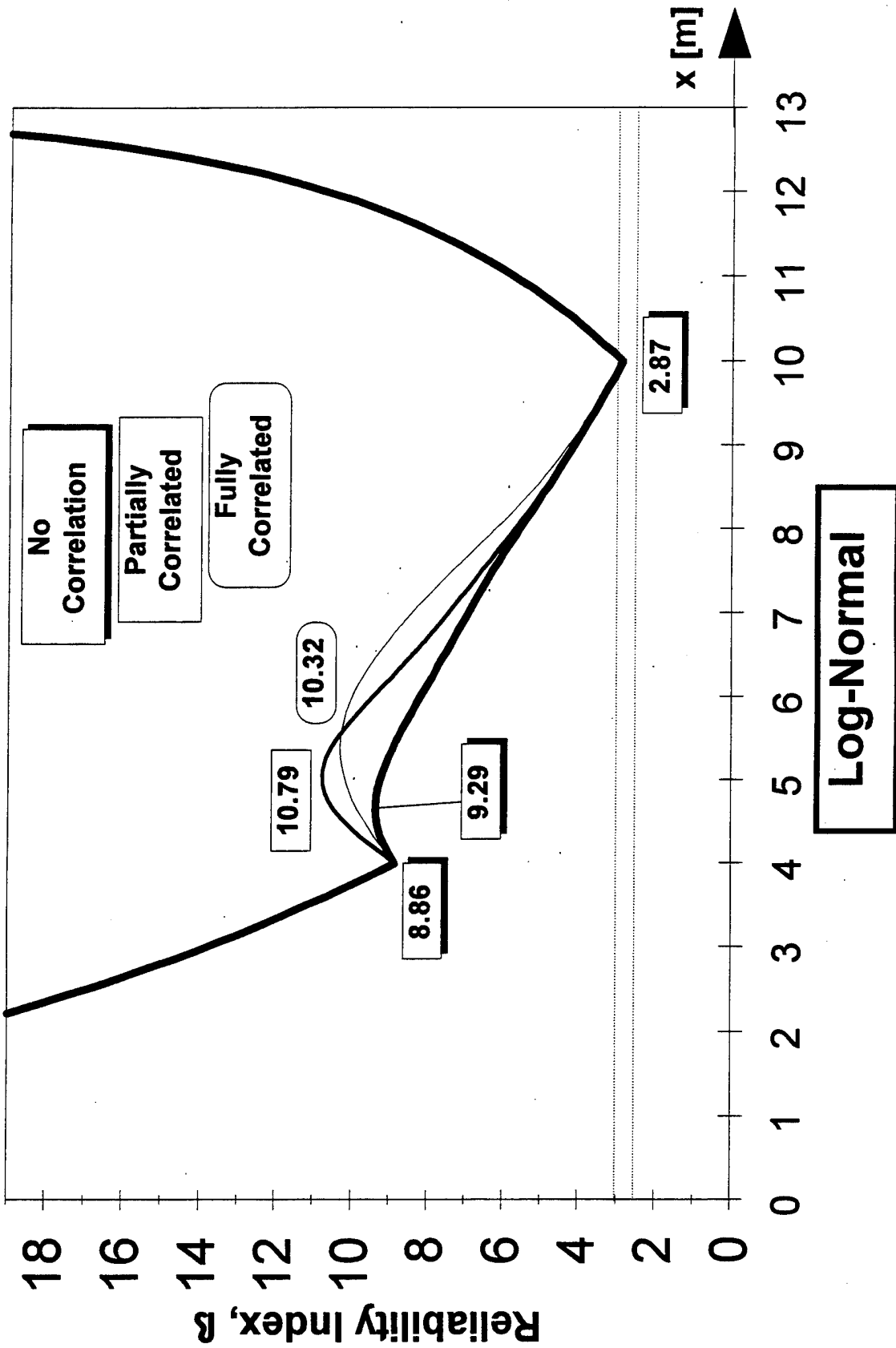

Moment "Factor of Safety" Diagram

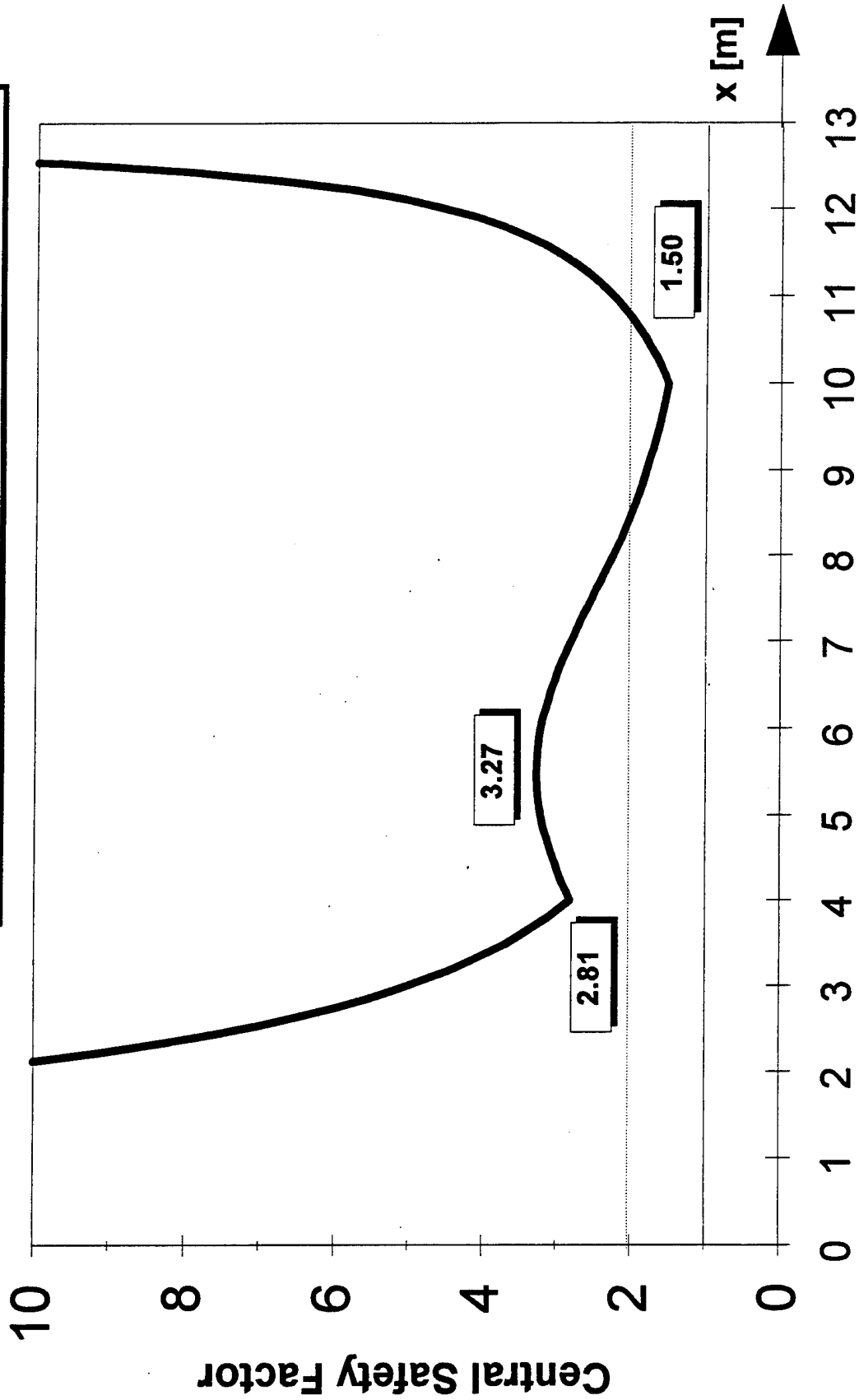

Reliability Index vs Safety Factor in Structures

Appendix B B4

Sample System 4

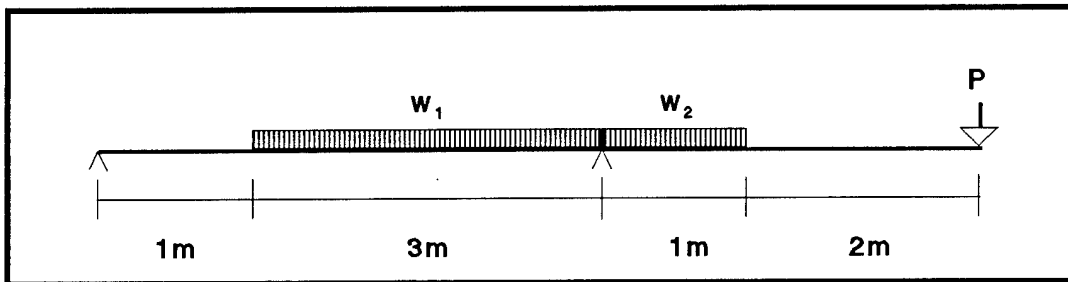

Figure 3.1d Simply Supported Beam, Cantilevered Right End (Laursen, p. 47, #2-9)

Contents

- 1-1 *N/A--design results only*
- 1-2 Design Step problem statement and minimum β results
- 2 Piecewise equations
- 3 Structural Analysis of Loads Diagrams
- 4 *N/A--design results only*
- 5 Design Step Reliability and Safety Factor Diagrams

SAMPLE SYSTEM 4

Simply Supported Beam, Cantilevered Right End

Three random loads

Two distributed loads, One concentrated load

Assume normal, then log-normal, distribution for load and resistance

Uniform beam

Problem Find location of minimum reliability.

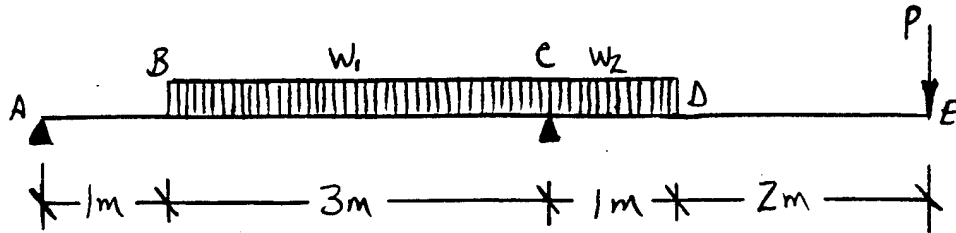

Loading

	Mean		C.O.V.
	(kN)	(KN/m)	
w1	-	4	8%
w2	-	4	10%
P	8	-	8%

Load Correlation

Correlation Coefficients	Case i	Case ii	Case iii
$\rho (w_1, w_2)$	0	1	1
$\rho (w_1, P)$	0	0	1
$\rho (w_2, P)$	0	0	1

Capacity

Shear: $V(R)_{\text{beam}} = 10\%$

Moment: $V(R)_{\text{beam}} = 10\%$

Sample Results

		min B	x (m)	\check{R}	\check{S}	V(S)	Correlation
Shear (kN)	N	2.57	4.00	13.50	9.50	0.08	Case iii
	LN	2.72	4.00	13.50	9.50	0.08	Case iii
Moment (kN-m)	N	2.66	4.00	11.50	8.00	0.08	Case iii
	LN	2.76	4.00	11.50	8.00	0.08	Case iii

Beam System 4

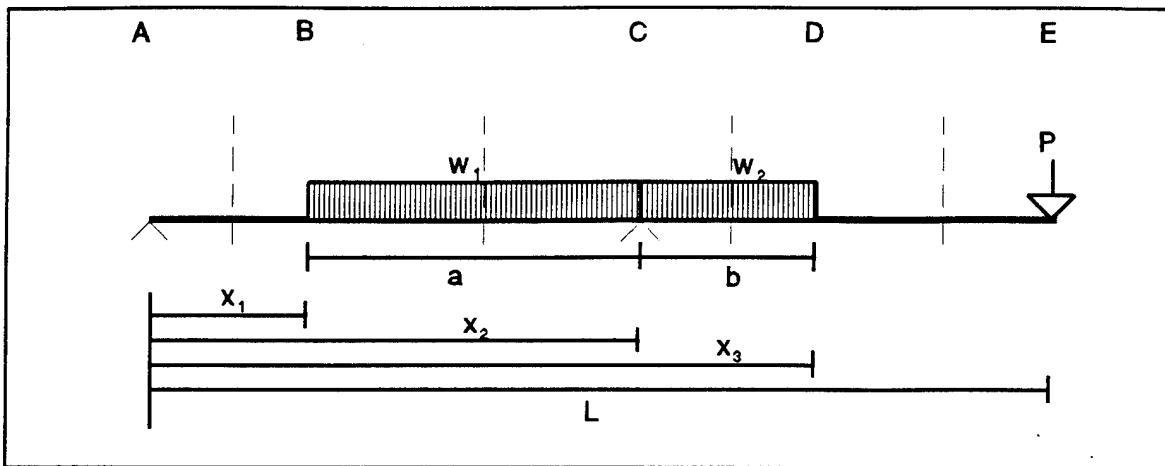

STATICS: Sum of Forces (vertical)

$$\sum F_V = 0$$

$$R_A + R_C = aw_1 + bw_2 + P$$

Sum of Moments (about point A)

$$\sum M_A = 0 \rightarrow R_A(x_2) - aw_1\left(\frac{a}{2}\right) + bw_2\left(\frac{b}{2}\right) + P(L - x_2)$$

$$R_A = aw_1\left(\frac{(a/2)}{x_2}\right) - bw_2\left(\frac{(b/2)}{x_2}\right) - P\left(\frac{L - x_2}{x_2}\right)$$

Sum of Moments (about point C)

$$\sum M_C = 0 \rightarrow aw_1\left(x_1 + \frac{a}{2}\right) - R_C(x_2) + bw_2\left(x_2 + \frac{b}{2}\right) + P(L)$$

$$R_C = aw_1\left(\frac{x_1 + (a/2)}{x_2}\right) + bw_2\left(\frac{x_2 + (b/2)}{x_2}\right) + P\left(\frac{L}{x_2}\right)$$

NOTES

$$k = \frac{x_1 + (a/2)}{x_2}, m = \frac{x_2 + (b/2)}{x_2}, n = \left(\frac{L}{x_2}\right), r = \frac{(a/2)}{x_2}, s = \frac{(b/2)}{x_2}, t = \frac{L - x_2}{x_2}$$

Segment AB

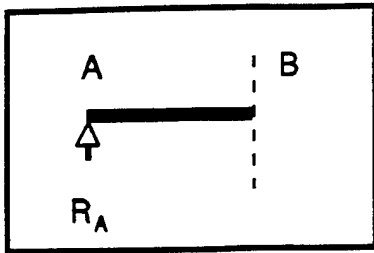

Shear

$$V = R_A$$

$$V = arw_1 - bsw_2 - tP$$

Shear Dispersion

$$\begin{aligned} \sigma_{S_V}^2 &= (ar)^2 \sigma_{w_1}^2 + (bs)^2 \sigma_{w_2}^2 + (t)^2 \sigma_P^2 \\ &\quad - 2\rho_{w_1 w_2} (ar)(bs) \sigma_{w_1} \sigma_{w_2} \\ &\quad - 2\rho_{w_1 P} (ar)(t) \sigma_{w_1} \sigma_P + 2\rho_{w_2 P} (bs)(t) \sigma_{w_2} \sigma_P \end{aligned}$$

Moment

$$M = R_A x$$

$$M = (arx)w_1 - (bsx)w_2 - (tx)P$$

Moment Dispersion

$$\begin{aligned} \sigma_{S_M}^2 &= (arx)^2 \sigma_{w_1}^2 + (bsx)^2 \sigma_{w_2}^2 + (tx)^2 \sigma_P^2 \\ &\quad - 2\rho_{w_1 w_2} (arx)(bsx) \sigma_{w_1} \sigma_{w_2} \\ &\quad - 2\rho_{w_1 P} (arx)(tx) \sigma_{w_1} \sigma_P + 2\rho_{w_2 P} (bsx)(tx) \sigma_{w_2} \sigma_P \end{aligned}$$

Segment BC

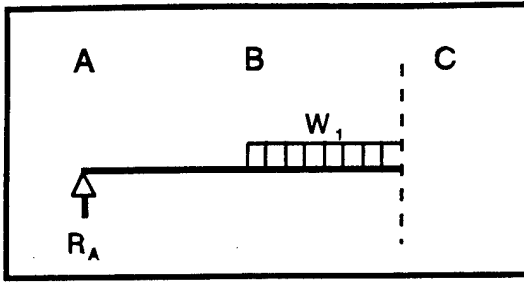

Shear

$$V = R_A - w_1 x$$

$$V = (ar + x_1 - x)w_1 - bsw_2 - tP$$

Shear Dispersion

$$\begin{aligned} \sigma_{s_v}^2 &= (ar + x_1 - x)^2 \sigma_{w_1}^2 + (bs)^2 \sigma_{w_2}^2 + (t)^2 \sigma_p^2 \\ &\quad - 2\rho_{w_1 w_2} (ar + x_1 - x)(bs) \sigma_{w_1} \sigma_{w_2} \\ &\quad - 2\rho_{w_1 p} (ar + x_1 - x)(t) \sigma_{w_1} \sigma_p + 2\rho_{w_2 p} (bs)(t) \sigma_{w_2} \sigma_p \end{aligned}$$

Moment

$$M = R_A x - w_1 \frac{(x - x_1)^2}{2}$$

$$M = \left(arx - \frac{(x - x_1)^2}{2} \right) w_1 - (bsx)w_2 - (tx)P$$

Moment Dispersion

$$\begin{aligned} \sigma_{s_M}^2 &= \left[arx - \frac{(x - x_1)^2}{2} \right]^2 \sigma_{w_1}^2 + (bsx)^2 \sigma_{w_2}^2 + (tx)^2 \sigma_p^2 \\ &\quad - 2\rho_{w_1 w_2} \left[arx - \frac{(x - x_1)^2}{2} \right] (bsx) \sigma_{w_1} \sigma_{w_2} \\ &\quad - 2\rho_{w_1 p} \left[arx - \frac{(x - x_1)^2}{2} \right] (tx) \sigma_{w_1} \sigma_p + 2\rho_{w_2 p} (bsx)(tx) \sigma_{w_2} \sigma_p \end{aligned}$$

Segment CD

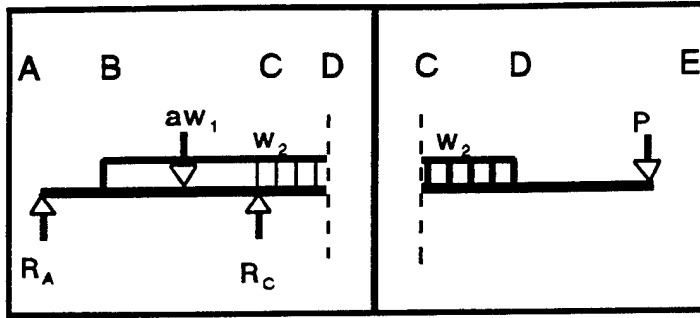

Notes

$$x \text{ | from left } \rightarrow +V, +M$$

$$x \text{ | from right } \rightarrow -V, +M$$

Shear

$$V = R_A + R_C - aw_1 - w_2(x - x_2) \quad +V = +w_2(x_3 - x) + P$$

$$V = (b + x_2 - x)w_2 + P \quad V = (x_3 - x)w_2 + P$$

Shear Dispersion

$$\sigma_{s_V}^2 = (x_3 - x)^2 \sigma_{w_2}^2 + \sigma_P^2 + 2\rho_{w_2 P} (x_3 - x) \sigma_{w_2} \sigma_P$$

Moment

$$M = -\left[\frac{(x_3 - x)^2}{2}\right]w_2 - (L - x)P$$

Moment Dispersion

$$\sigma_{s_M}^2 = \left[\frac{(x_3 - x)^2}{2}\right]^2 \sigma_{w_2}^2 + (x - L)^2 \sigma_P^2 - 2\rho_{w_2 P} \left[\frac{(x_3 - x)^2}{2}\right] (x - L) \sigma_{w_2} \sigma_P$$

Segment DE

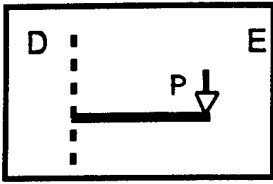

Shear

$$+V = +P$$

Shear Dispersion

$$\sigma_{s_v}^2 = \sigma_p^2$$

Moment

$$M = -P(L - x)$$

Moment Dispersion

$$\sigma_{s_M}^2 = (L - x)^2 \sigma_p^2$$

Shear Diagram

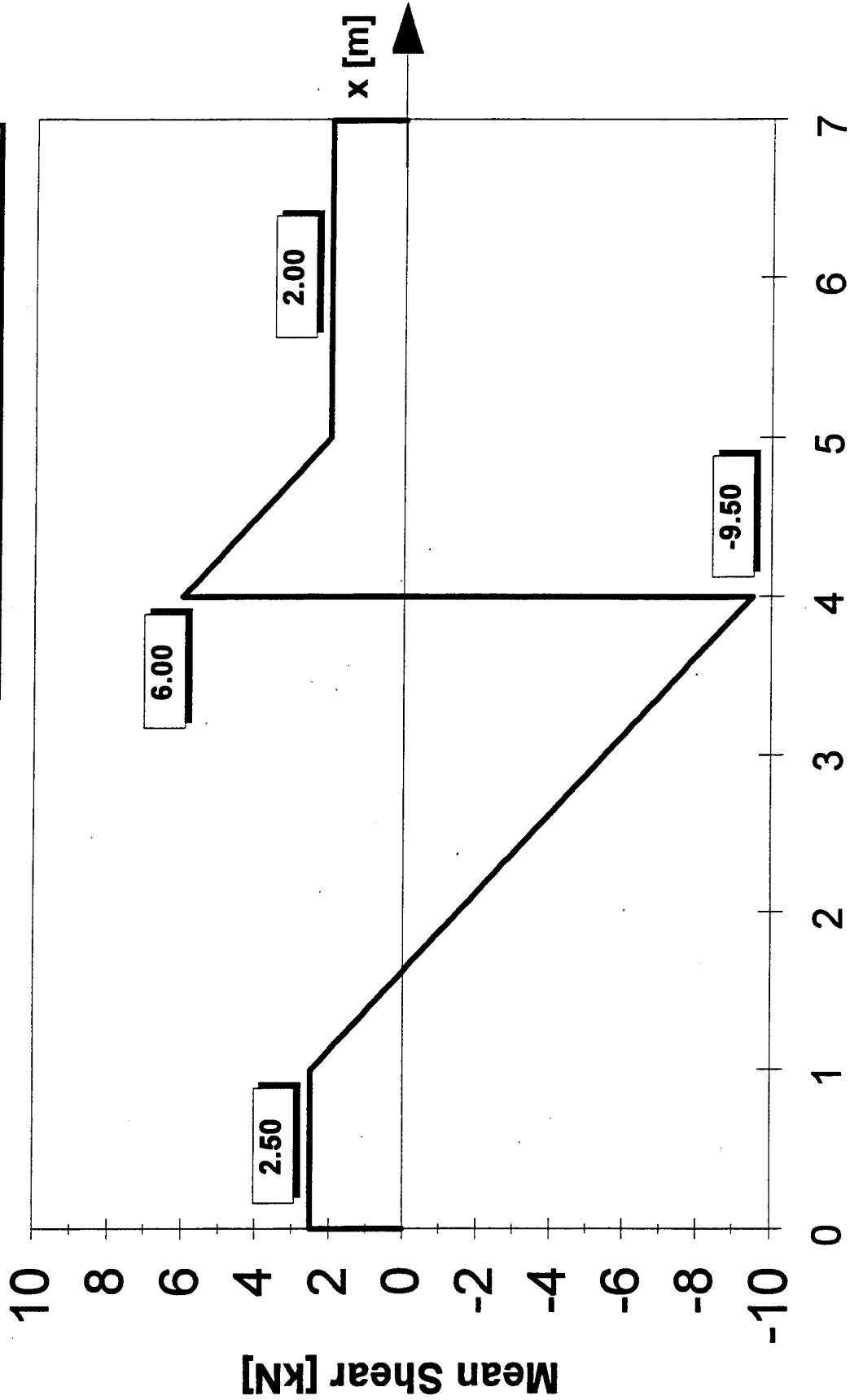

Shear Dispersion Diagram

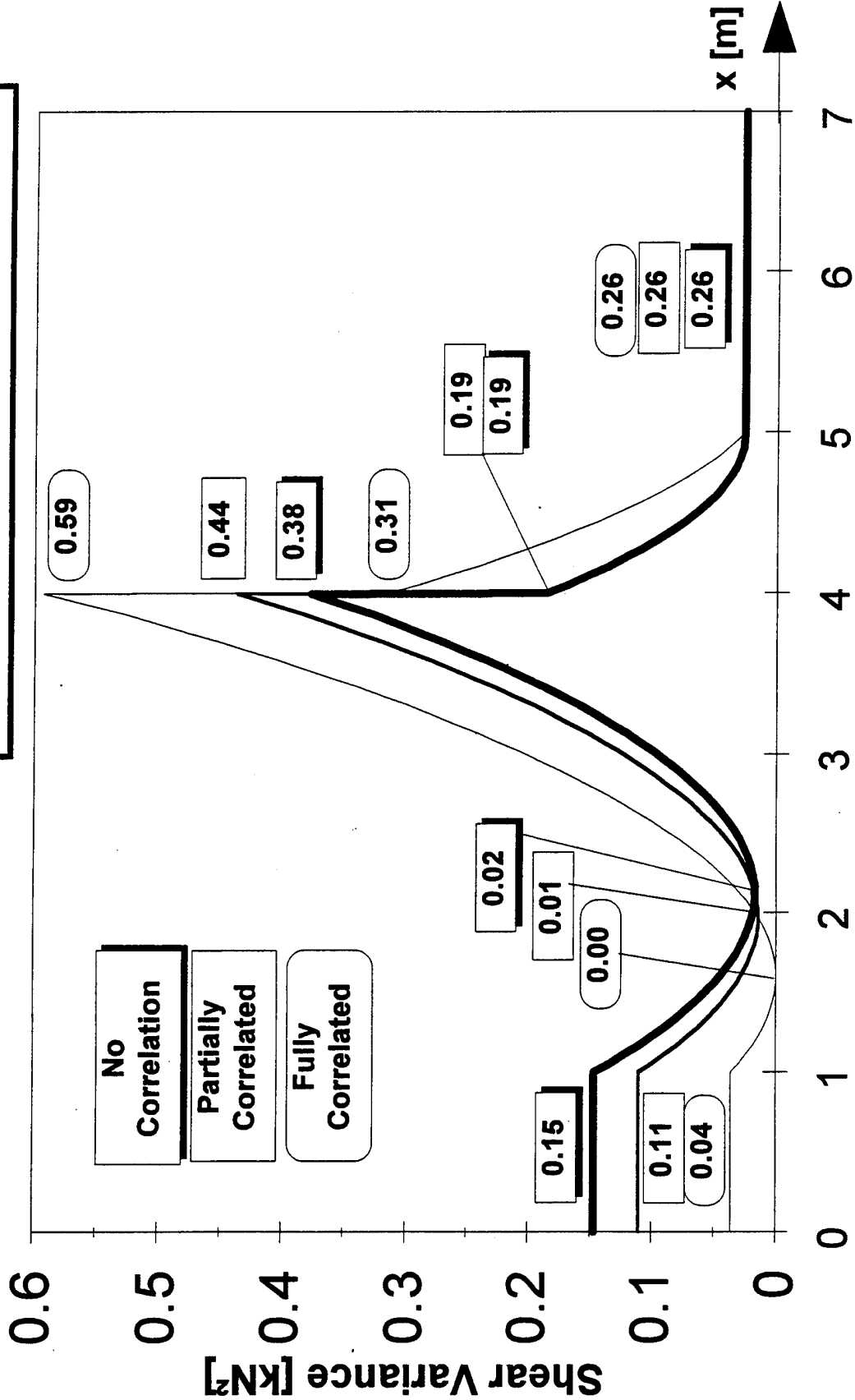

Moment Diagram

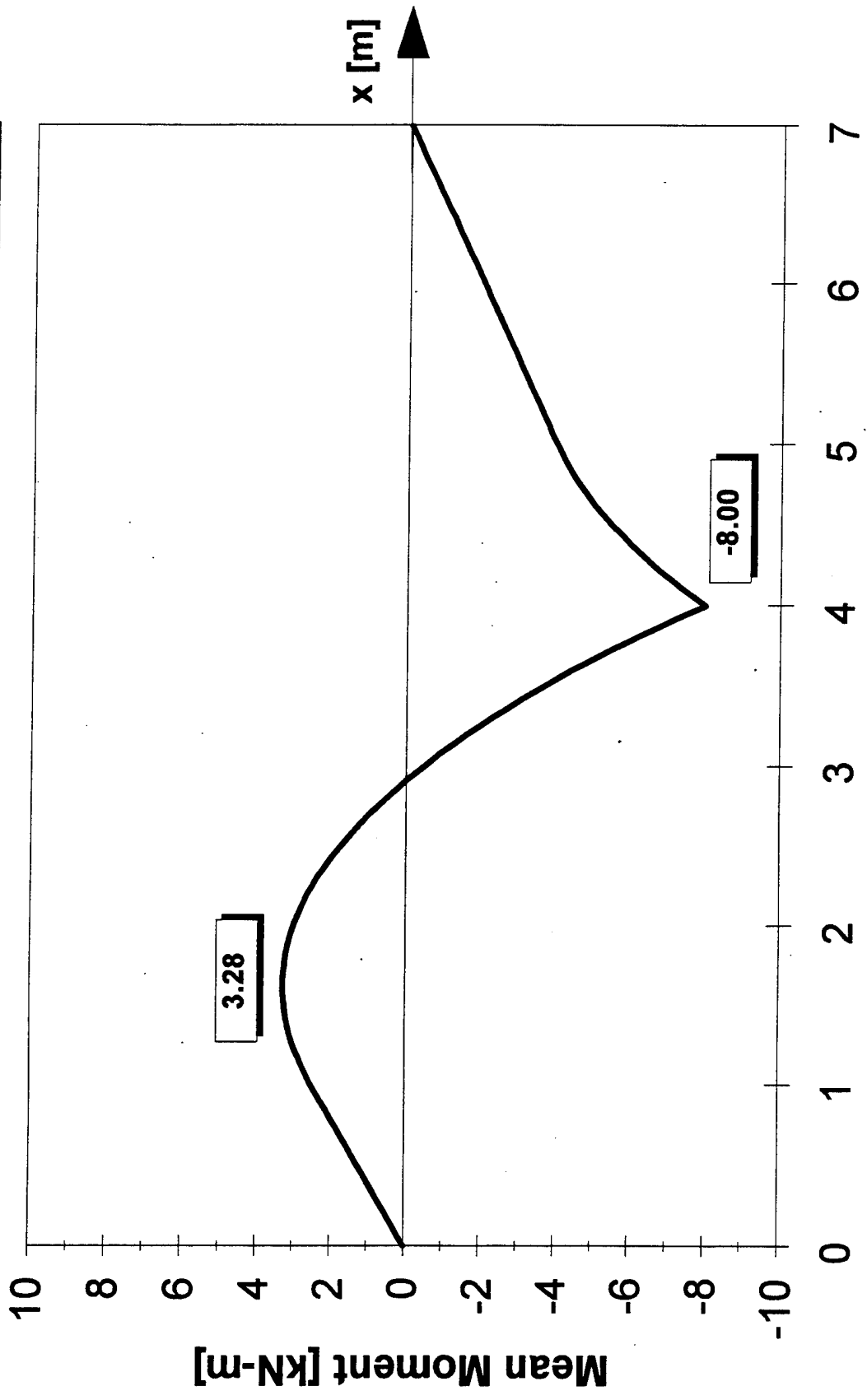

Moment Dispersion Diagram

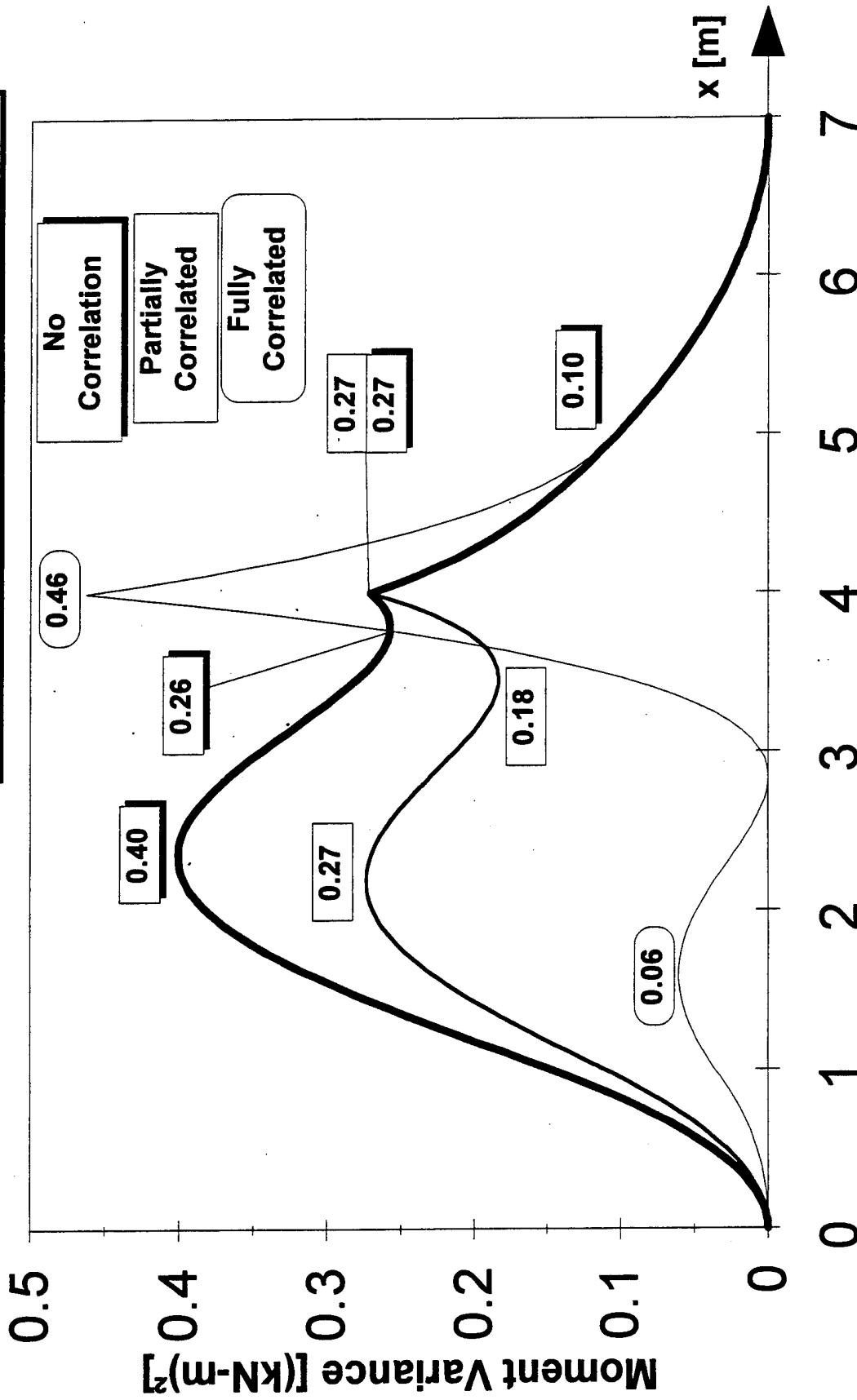

Shear Reliability Diagram

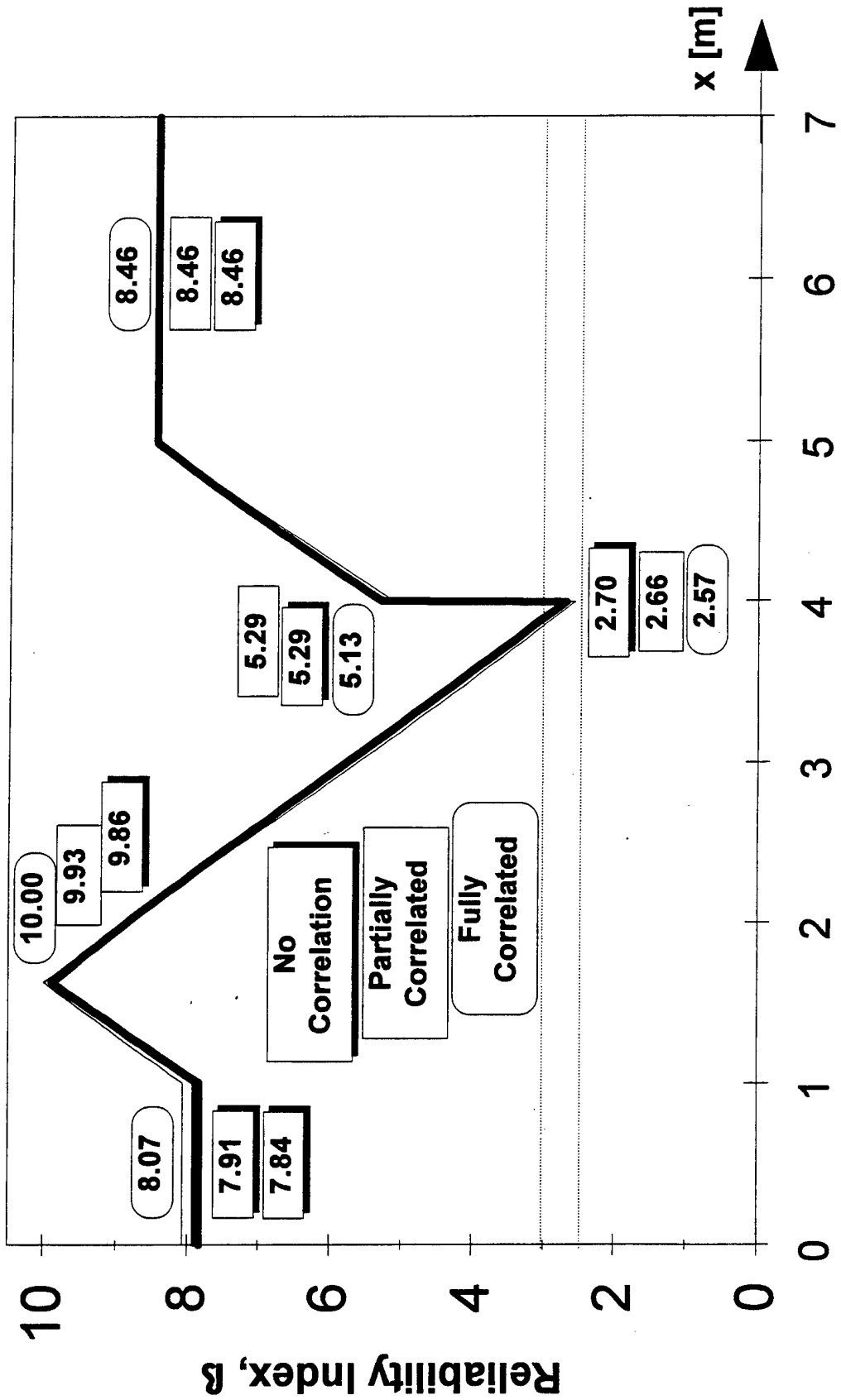

Shear Reliability Diagram

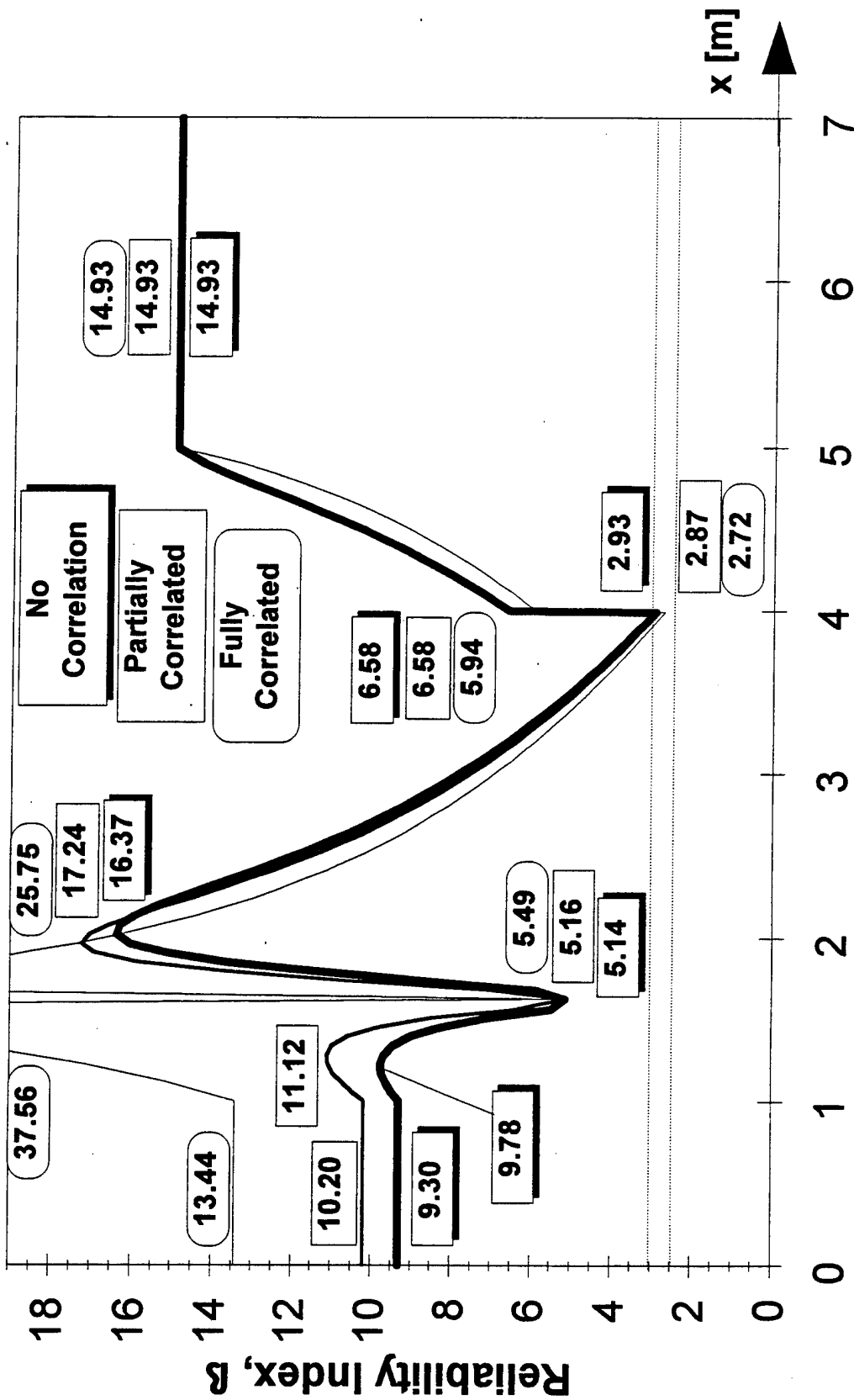

Log-Normal

Shear "Factor of Safety" Diagram

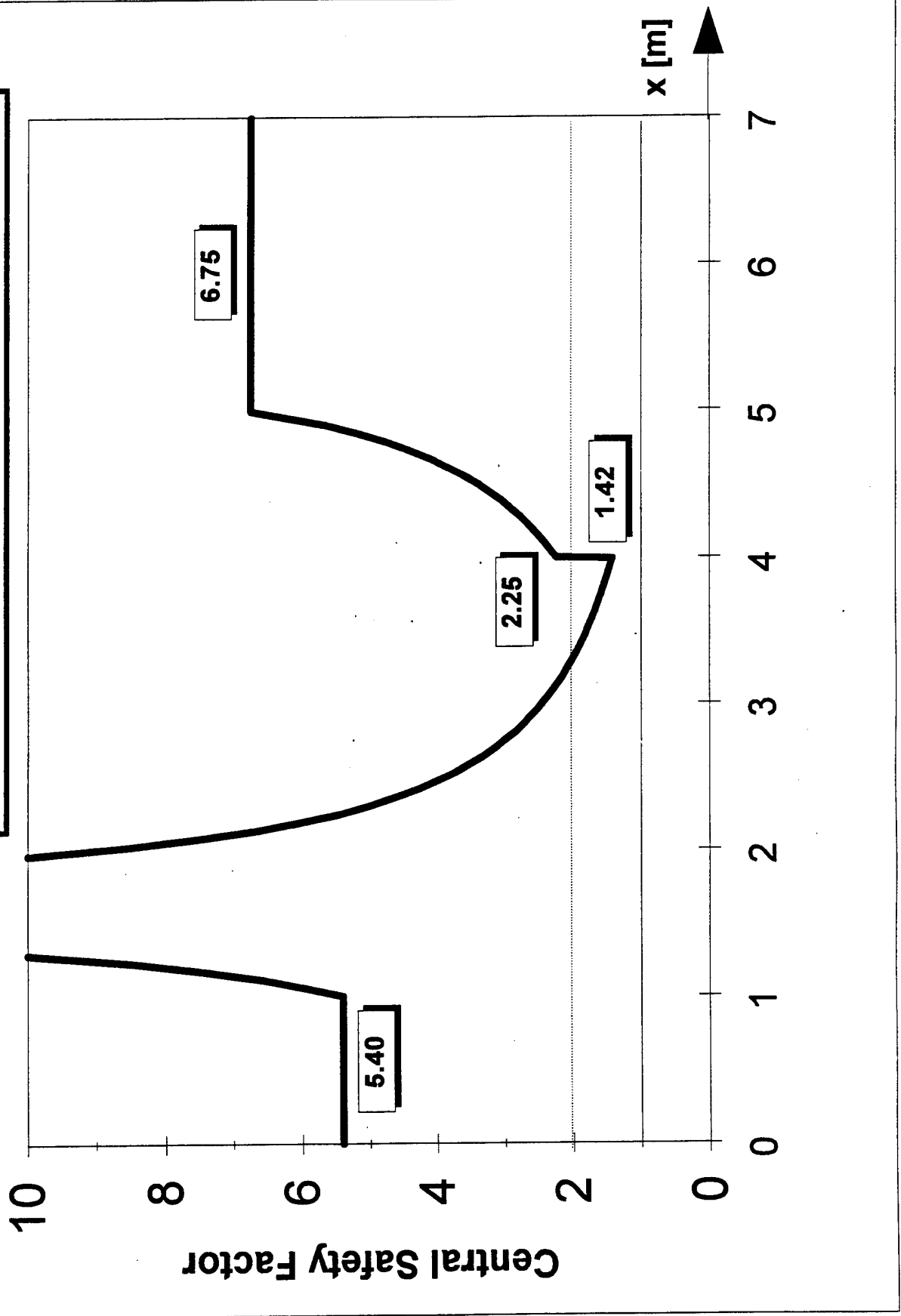

Moment Reliability Diagram

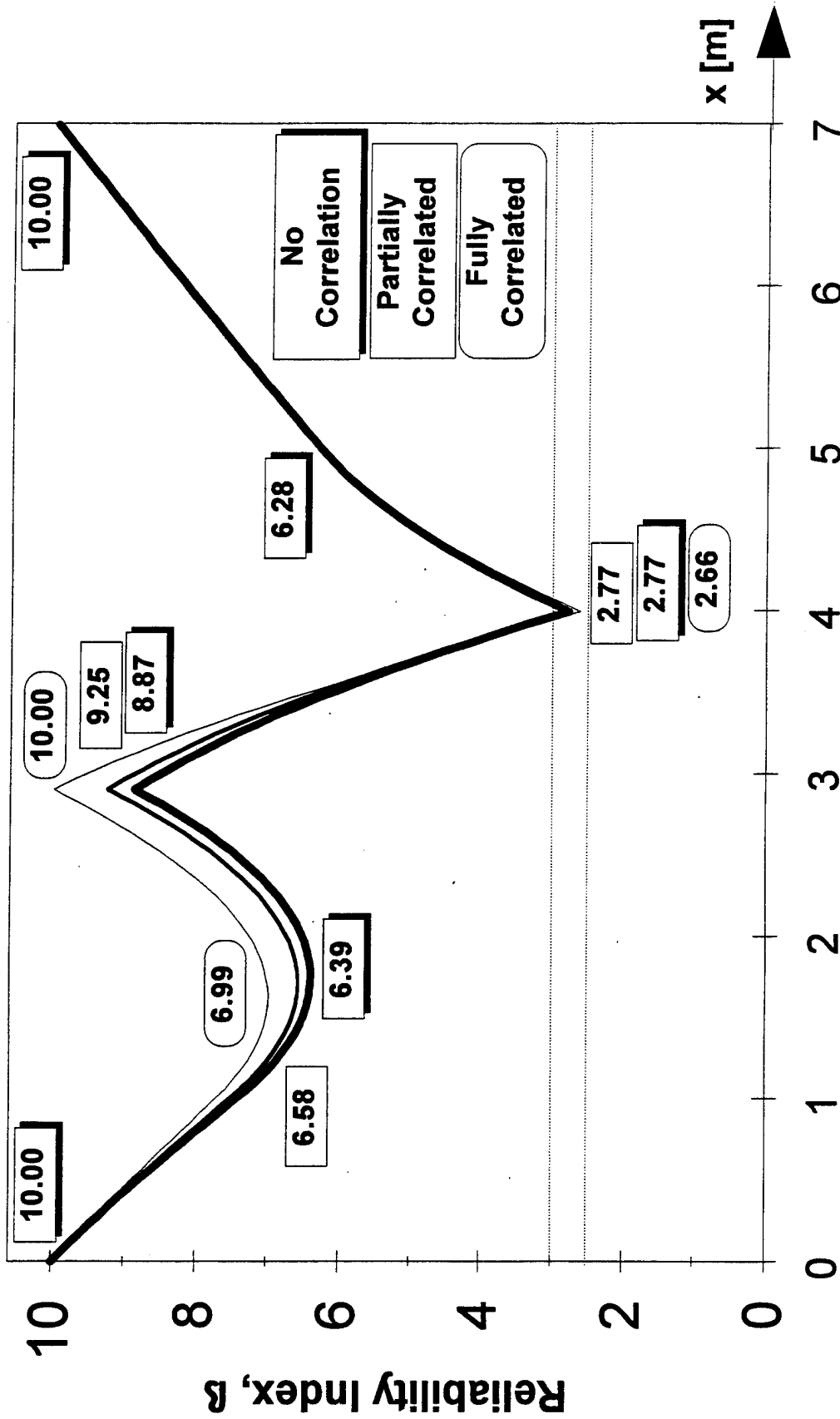

Moment Reliability Diagram

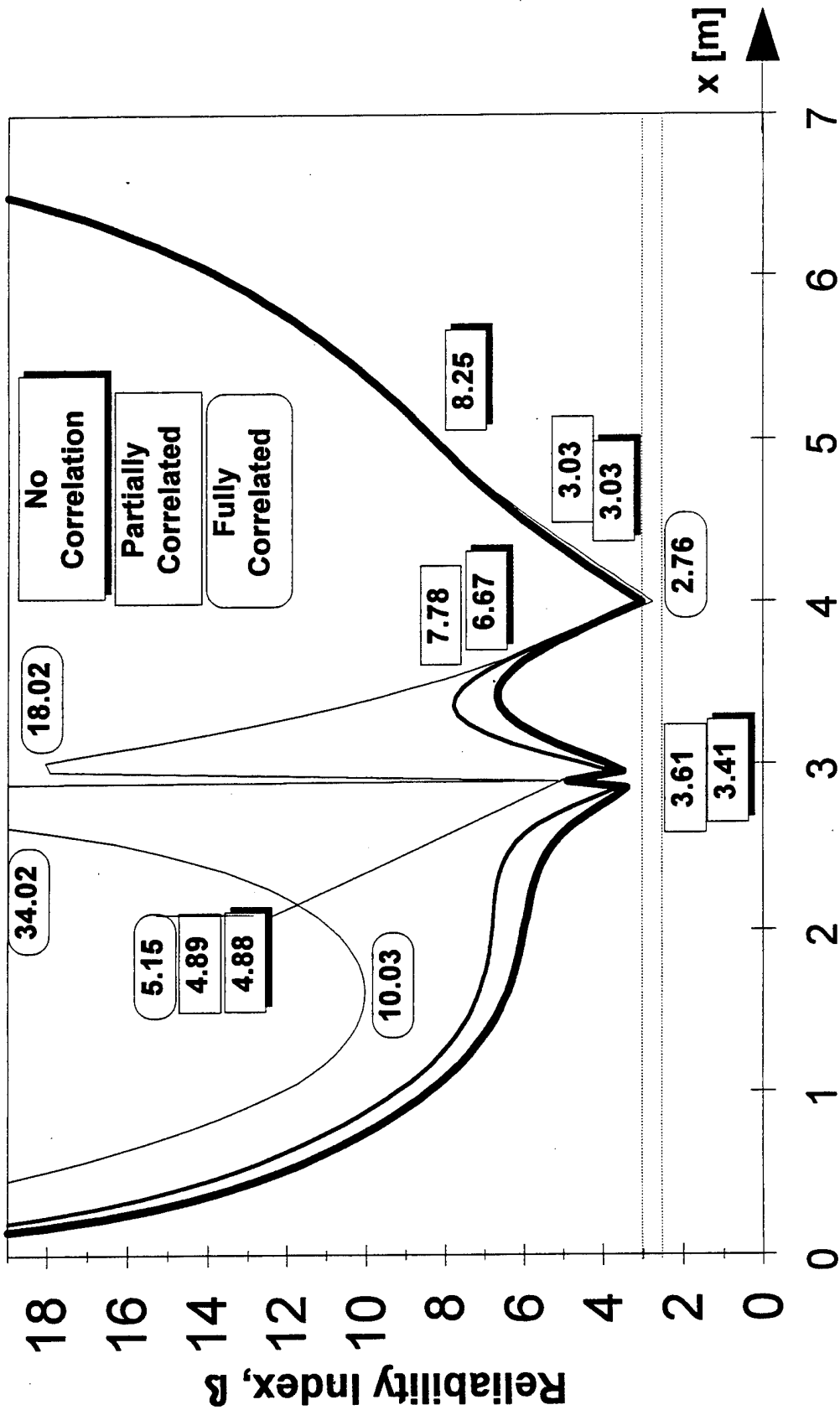

Log-Normal

Moment "Factor of Safety" Diagram

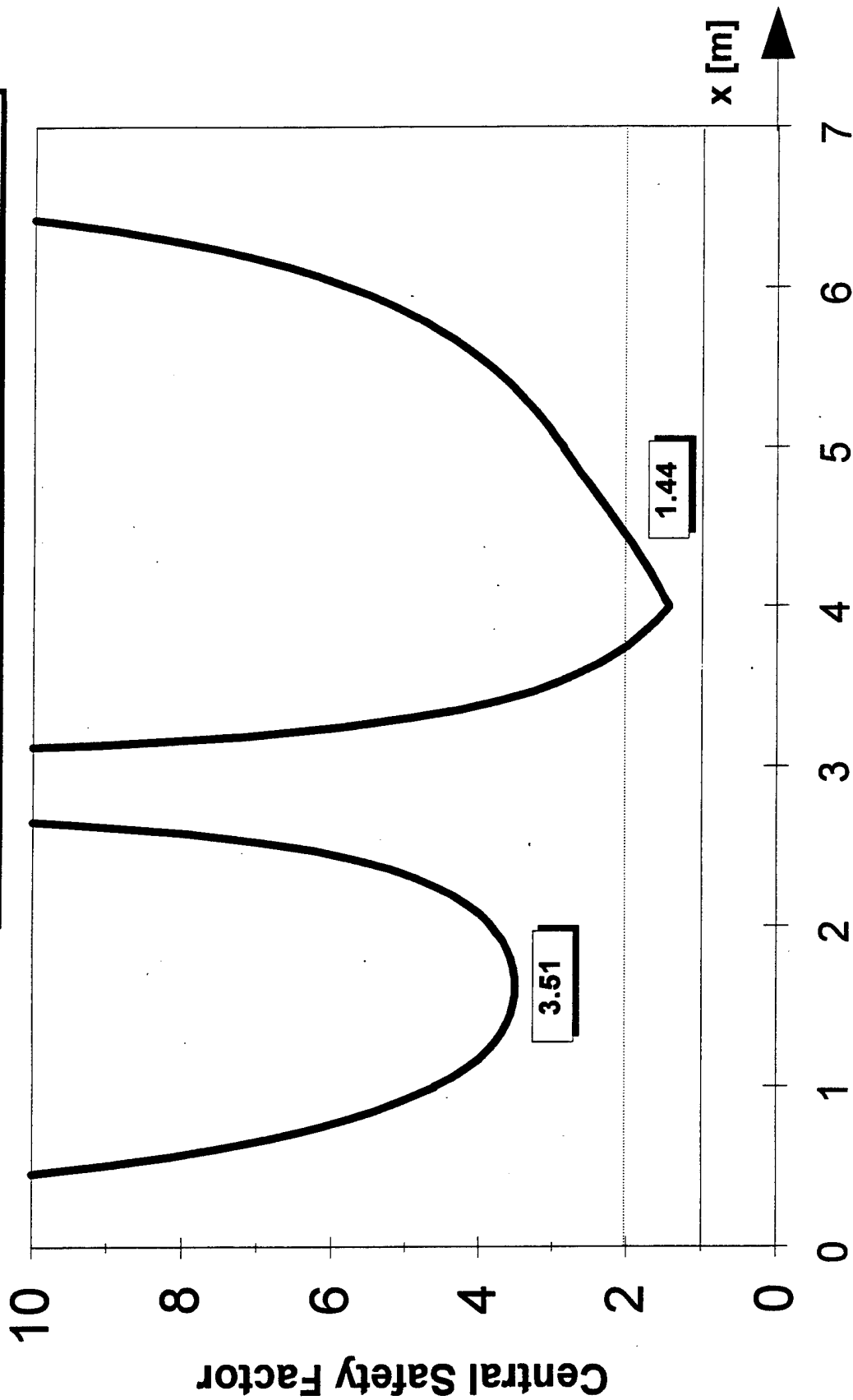

Reliability Index vs Safety Factor in Structures

Appendix B B5

Sample System 5

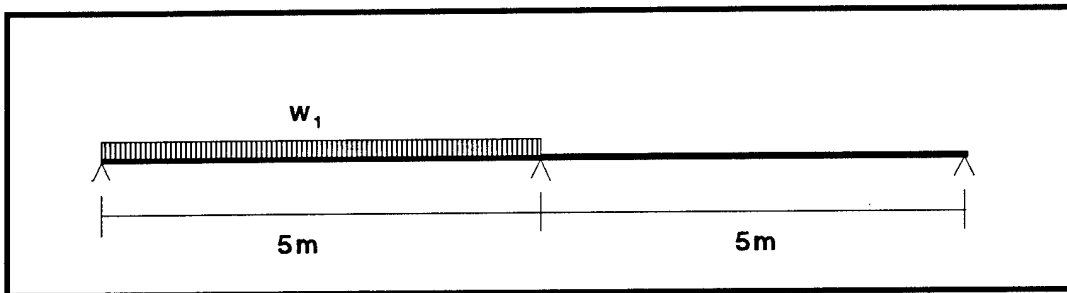

Figure 3.1e Indeterminate Beam [first degree] (AISC, p. 2-306, #29)

Contents

- 1-1 *N/A--design results only*
- 1-2 Design Step problem statement and minimum β results
- 2 Piecewise equations
- 3 Structural Analysis of Loads Diagrams
- 4 *N/A--design results only*
- 5 Design Step Reliability and Safety Factor Diagrams

SAMPLE SYSTEM 5

Simply Supported, Indeterminant (first degree) Beam

One random, distributed loads

Uniform beam has two equal spans

Assume normal, then log-normal, distribution for load and resistance

Problem Find location of minimum reliability.

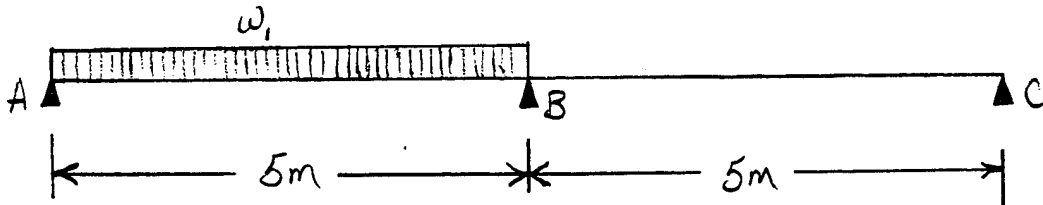

Loading

	Mean (KN/m)	C.O.V.
w1	4	15%

Load Correlation

Correlation Coefficient	Case <i>i</i>
ρ	None

Capacity

Shear: $V(R)_{\text{beam}} = 10\%$
Moment: $V(R)_{\text{beam}} = 10\%$

Sample Results

		min β	x (m)	Span	\bar{R}	\bar{S}	V(S)
Shear (kN)	N	2.74	5.00	AB	18.00	11.25	0.15
	LN	2.65	5.00	AB	18.00	11.25	0.15
Moment (kN-m)	N	2.99	2.16	AB	16.00	9.57	0.15
	LN	2.78	2.16	AB	16.00	9.57	0.15

Beam System 5

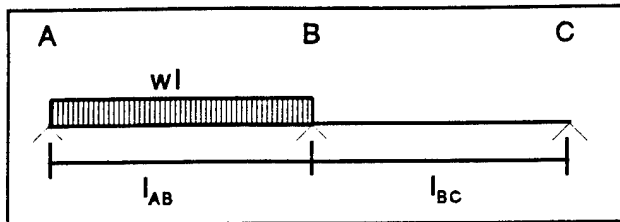

STATICS

Sum of Forces (vertical)

$$\sum F_V = 0$$
$$R_A + R_B + R_C = w L_{AB}$$

Sum of Moments (about point A)

$$\sum M_A = 0 \quad - \quad w L_{AB} \left(\frac{L_{AB}}{2} \right) - R_B L_{AB} - R_C (L_{AB} + L_{BC})$$
$$R_B = w \left(\frac{L_{AB}}{2} \right) - R_C \left(\frac{L_{AB} + L_{BC}}{L_{AB}} \right)$$

DISPLACEMENT METHOD

$$\Delta_B + R_B \delta_B = 0$$
$$EI \Delta_B + R_B EI \delta_B = 0$$

Displacement Method

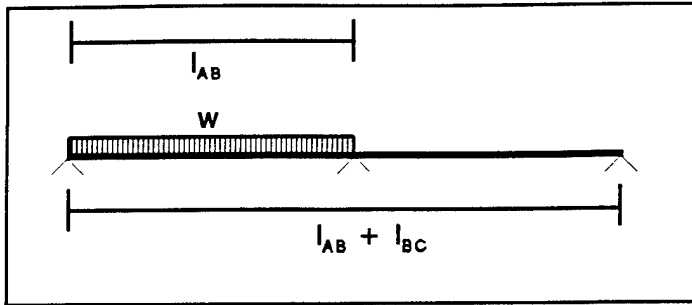

$$EI\Delta_B = w \left(\frac{L_{AB}}{24} \right) \left[\frac{L_{AB}^3 L_{BC} + 4L_{AB}^2 L_{BC}^2}{L_{AB} + L_{BC}} \right]$$

$$EI\delta_B = \frac{(L_{AB} + L_{BC})^3}{48}$$

$$R_B = 2w \left[\frac{L_{AB}^4 L_{BC} + 4L_{AB}^3 L_{BC}^2}{(L_{AB} + L_{BC})^4} \right]$$

Reactions

$$R_A = \frac{3}{4}wL_{AB} - w \left[\frac{L_{AB}^4 L_{BC} + 4L_{AB}^3 L_{BC}^2}{(L_{AB} + L_{BC})^4} \right]$$

$$R_C = \frac{1}{4}wL_{AB} - w \left[\frac{L_{AB}^4 L_{BC} + 4L_{AB}^3 L_{BC}^2}{(L_{AB} + L_{BC})^4} \right]$$

Segment AB

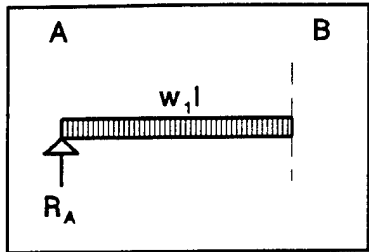

Shear

$$V = R_A - wx$$

$$V = \left[\frac{3}{4}L_{AB} - x - \left(\frac{L_{AB}^4 L_{BC} + 4L_{AB}^3 L_{BC}}{L_{AB} + L_{BC}} \right) \right] w$$

Shear Dispersion

$$\sigma_{S_V}^2 = \left[\frac{3}{4}L_{AB} - x - \left(\frac{L_{AB}^4 L_{BC} + 4L_{AB}^3 L_{BC}}{L_{AB} + L_{BC}} \right) \right]^2 \sigma_w^2$$

Moment

$$M = R_A x - \frac{x^2}{2} w$$

$$M = \left[\left(\frac{3}{4}L_{AB} - \left(\frac{L_{AB}^4 L_{BC} + 4L_{AB}^3 L_{BC}}{L_{AB} + L_{BC}} \right) \right) x - \frac{x^2}{2} \right] w$$

Moment Dispersion

$$\sigma_{S_M}^2 = \left[\left(\frac{3}{4}L_{AB} - \left(\frac{L_{AB}^4 L_{BC} + 4L_{AB}^3 L_{BC}}{L_{AB} + L_{BC}} \right) \right) x - \frac{x^2}{2} \right]^2 \sigma_w^2$$

Segment BC

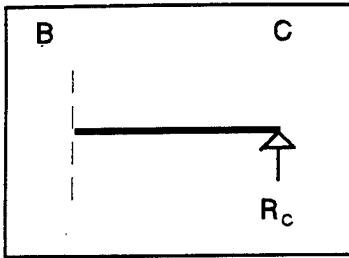

Shear

$$V = R_A - wx$$
$$V = \left[\frac{L_{AB}}{4} - \frac{L_{AB}^4 L_{BC} + 4L_{AB}^3 L_{BC}}{L_{AB} + L_{BC}} \right] w$$

Shear Dispersion

$$\sigma_{S_V}^2 = \left[\frac{L_{AB}}{4} - \frac{L_{AB}^4 L_{BC} + 4L_{AB}^3 L_{BC}}{L_{AB} + L_{BC}} \right]^2 \sigma_w^2$$

Moment

$$M = R_C (L_{AB} + L_{BC} - x)$$
$$M = \left[\frac{L_{AB}}{4} - \frac{L_{AB}^4 L_{BC} + 4L_{AB}^3 L_{BC}}{L_{AB} + L_{BC}} \right] (L_{AB} + L_{BC} - x) w$$

Moment Dispersion

$$\sigma_{S_M}^2 = \left[\left(\frac{L_{AB}}{4} - \frac{L_{AB}^4 L_{BC} + 4L_{AB}^3 L_{BC}}{L_{AB} + L_{BC}} \right) (L_{AB} + L_{BC} - x) \right]^2 \sigma_w^2$$

Shear Diagram

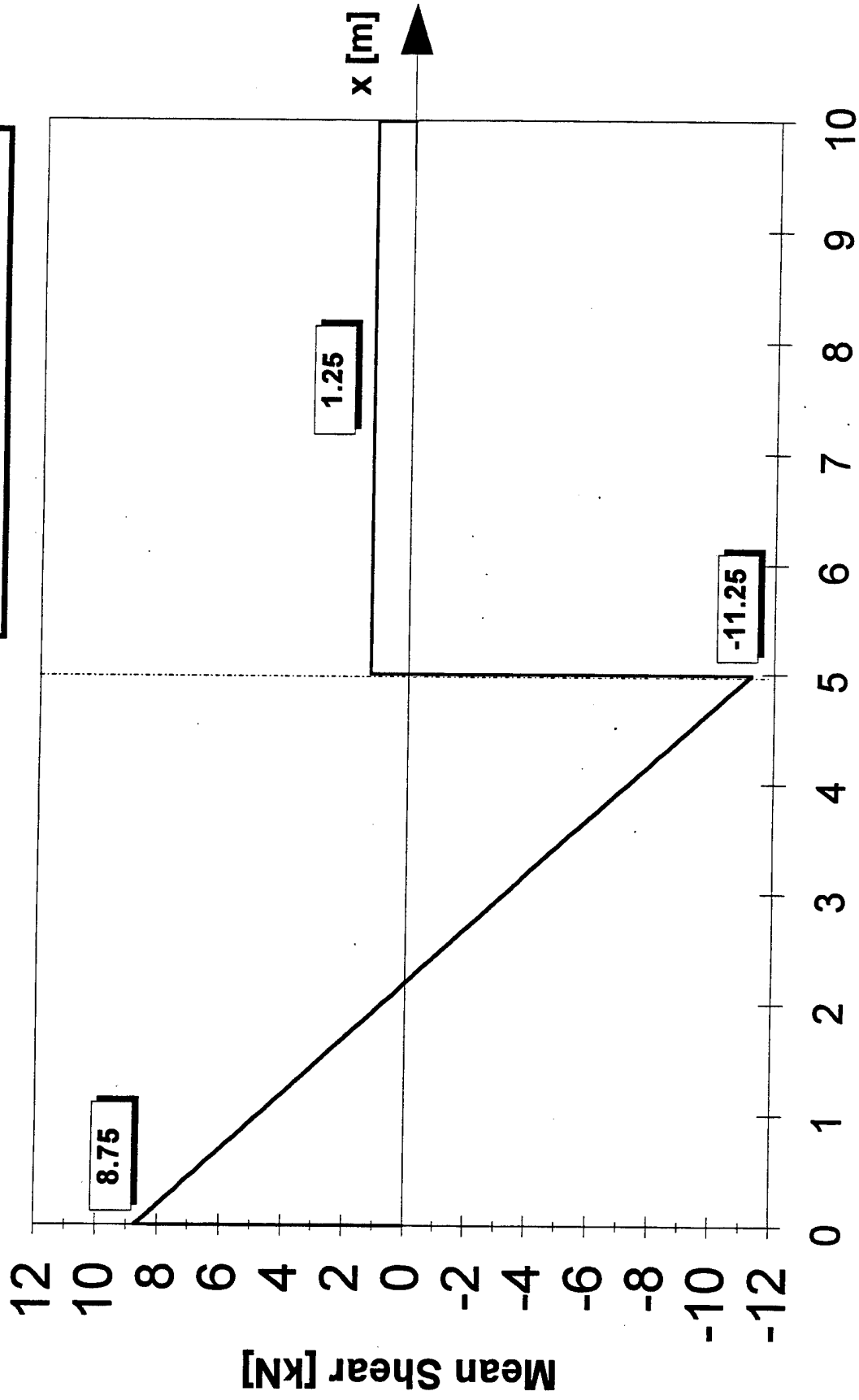

Shear Dispersion Diagram

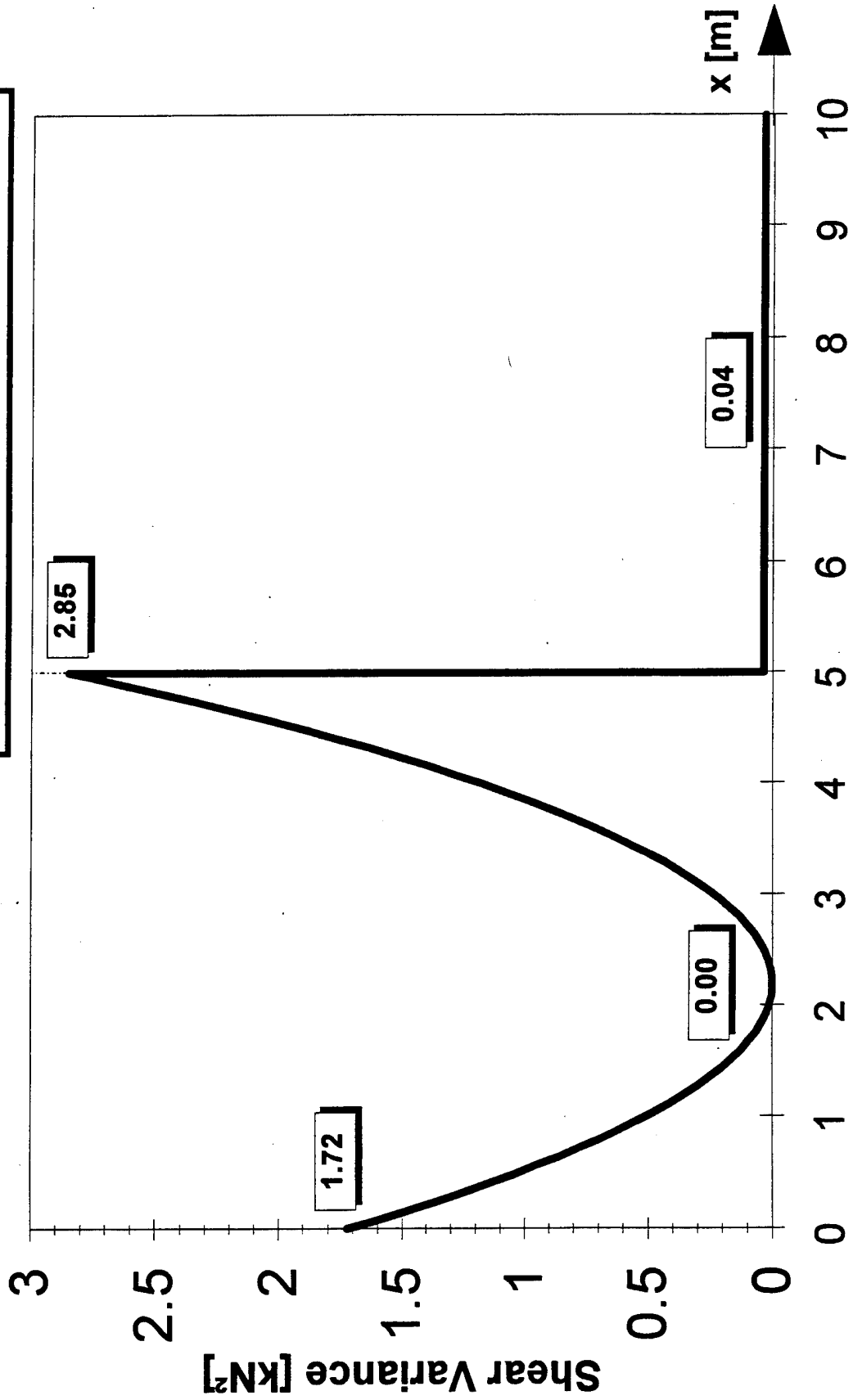

Moment Diagram

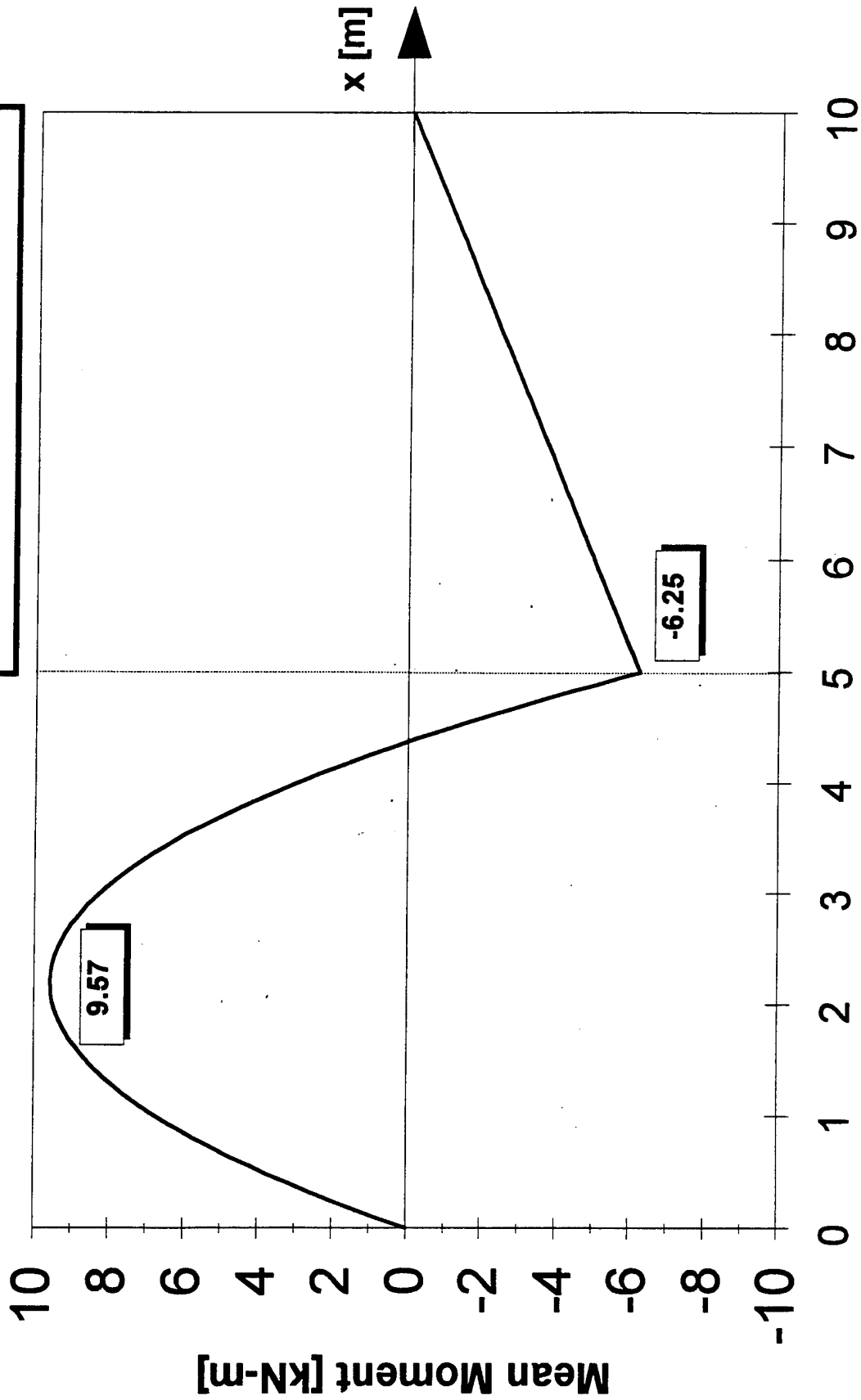

Moment Dispersion Diagram

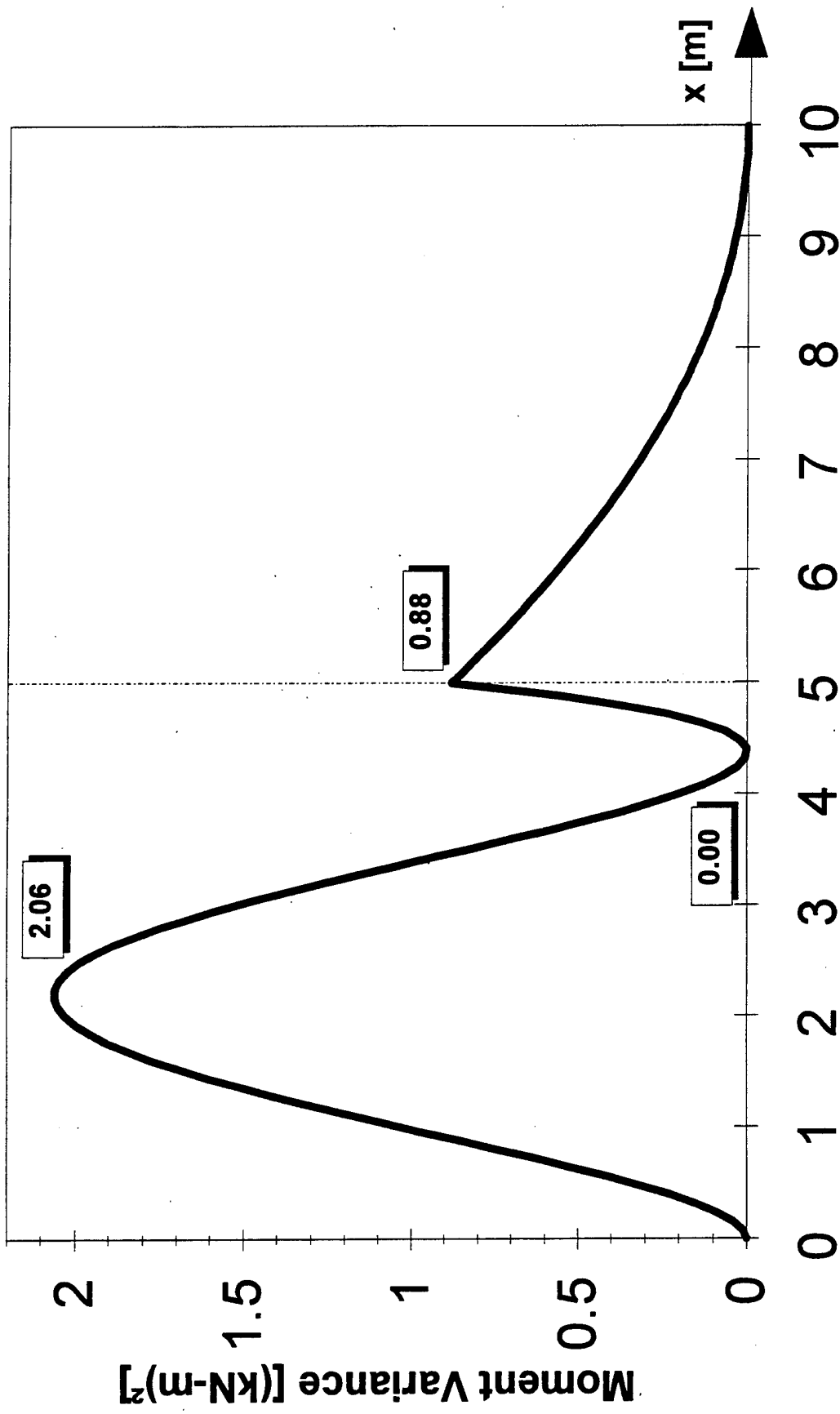

Shear Reliability Diagram

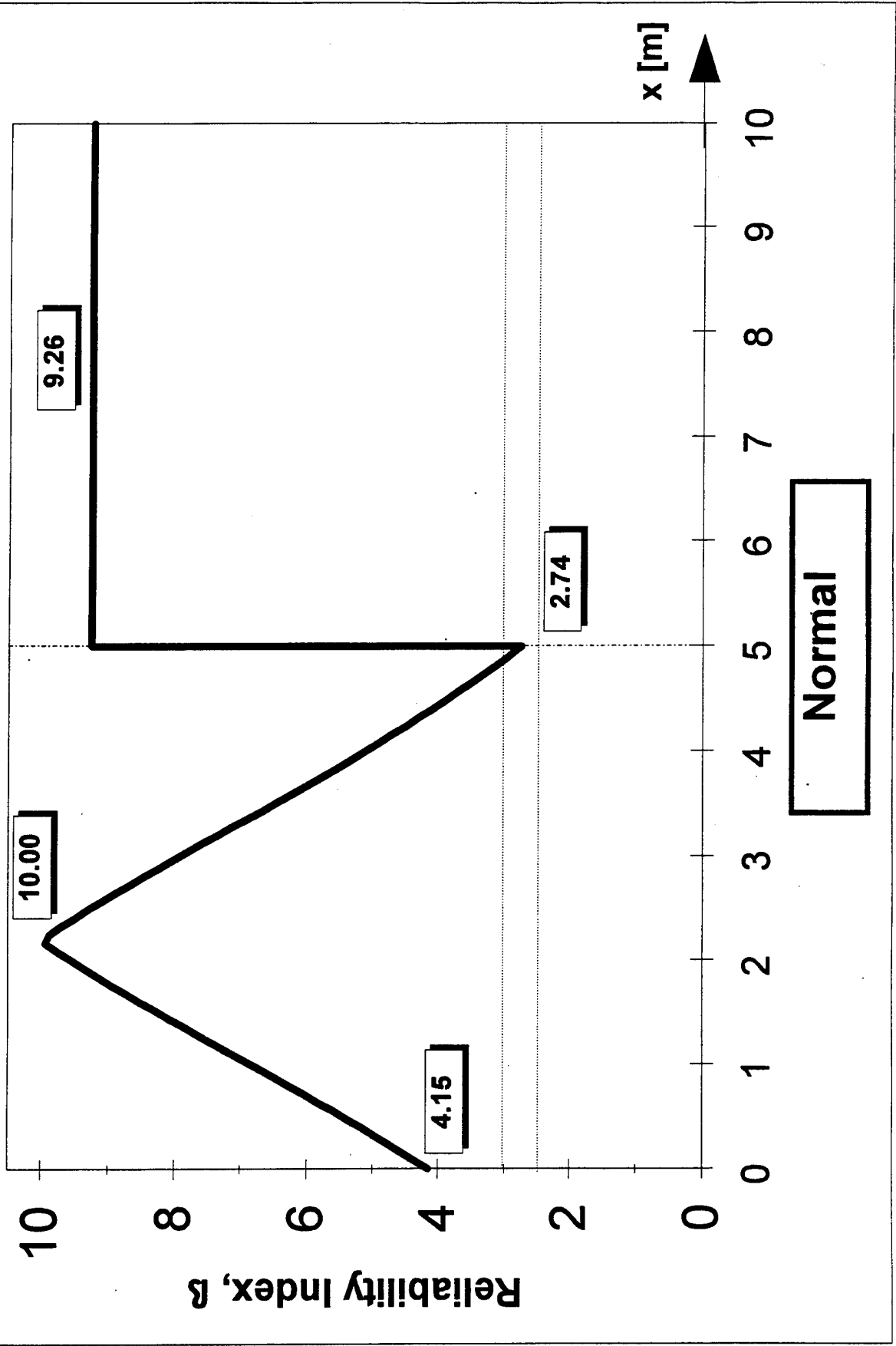

Shear Reliability Diagram

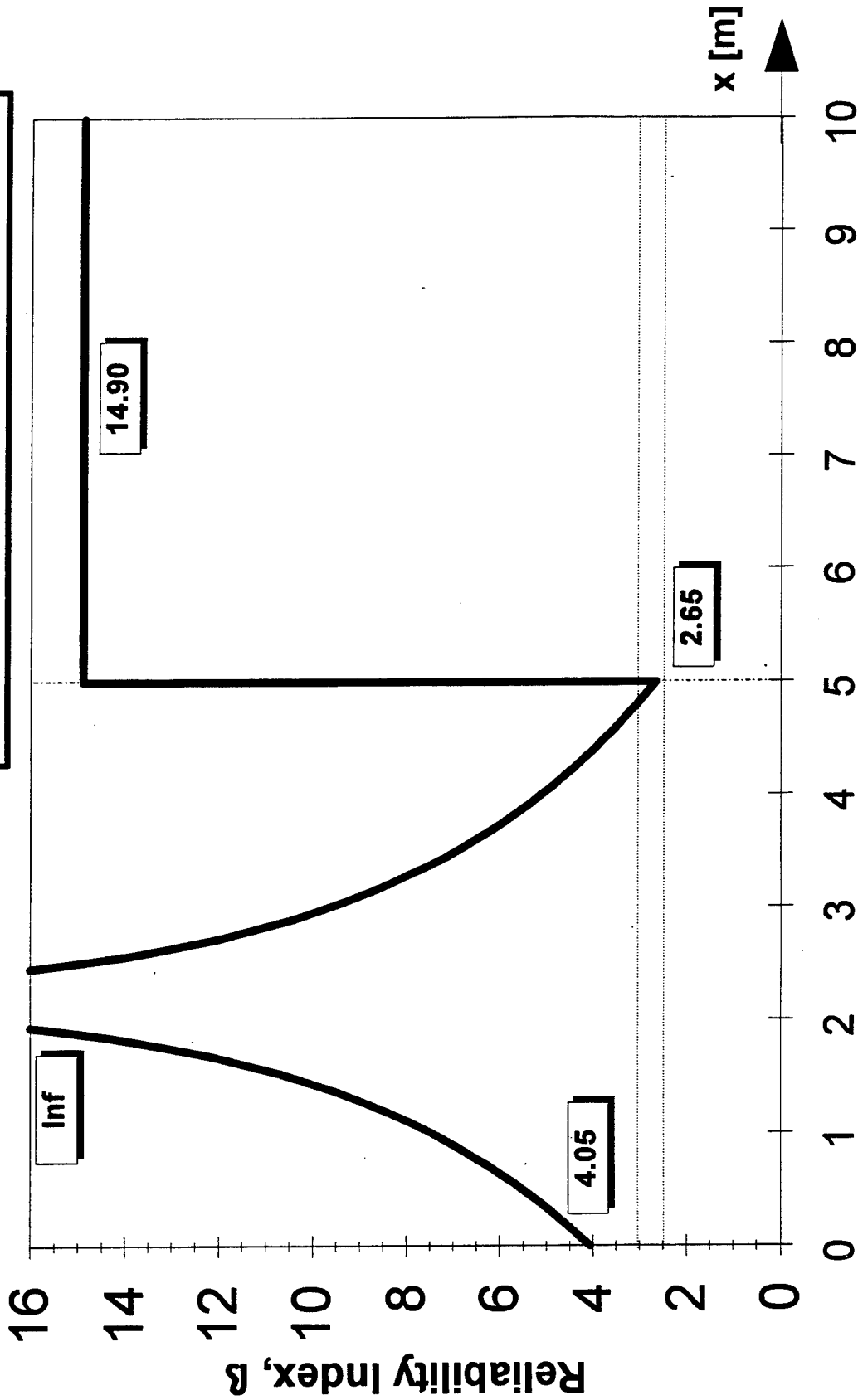

Log-Normal

Shear "Factor of Safety" Diagram

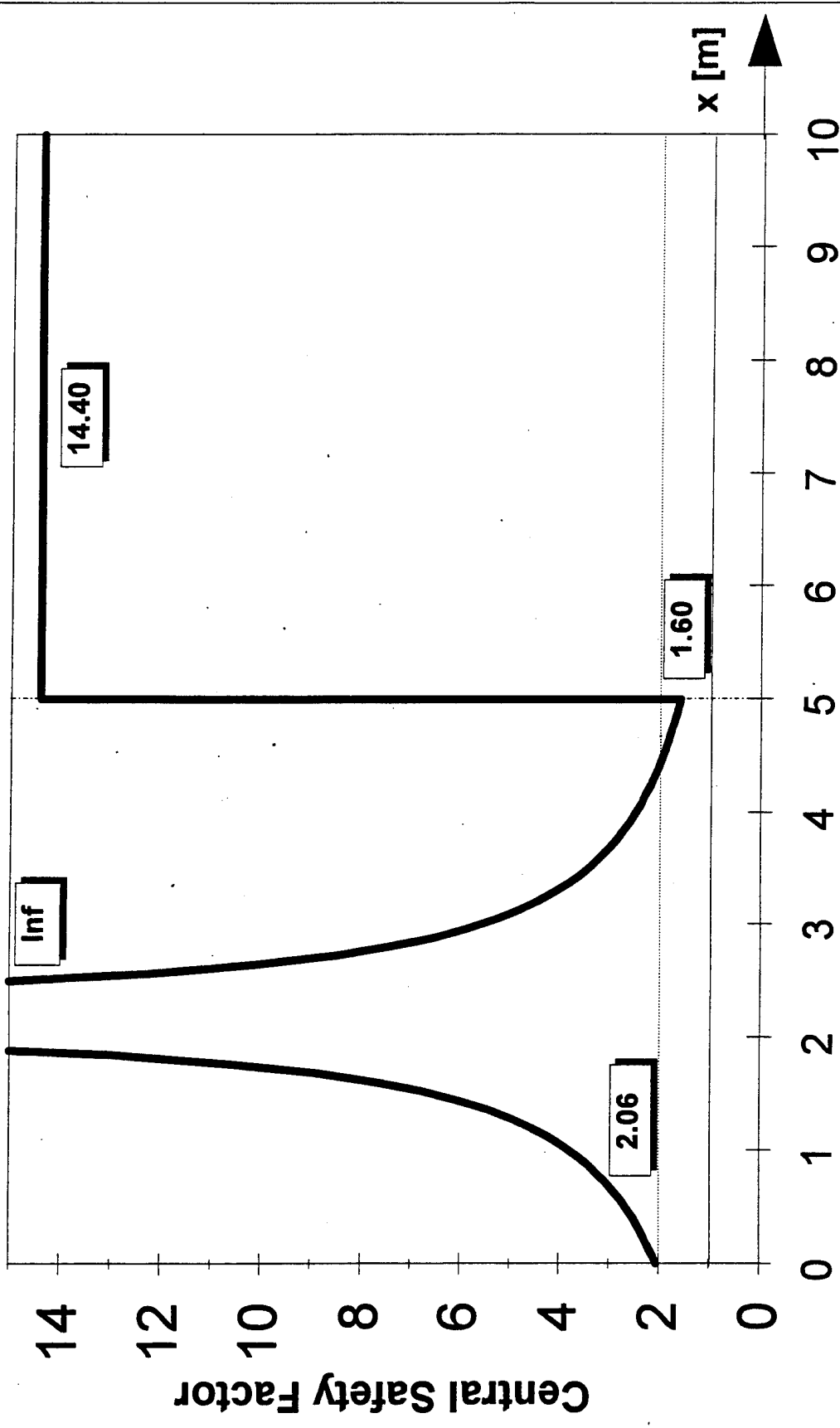

Moment Reliability Diagram

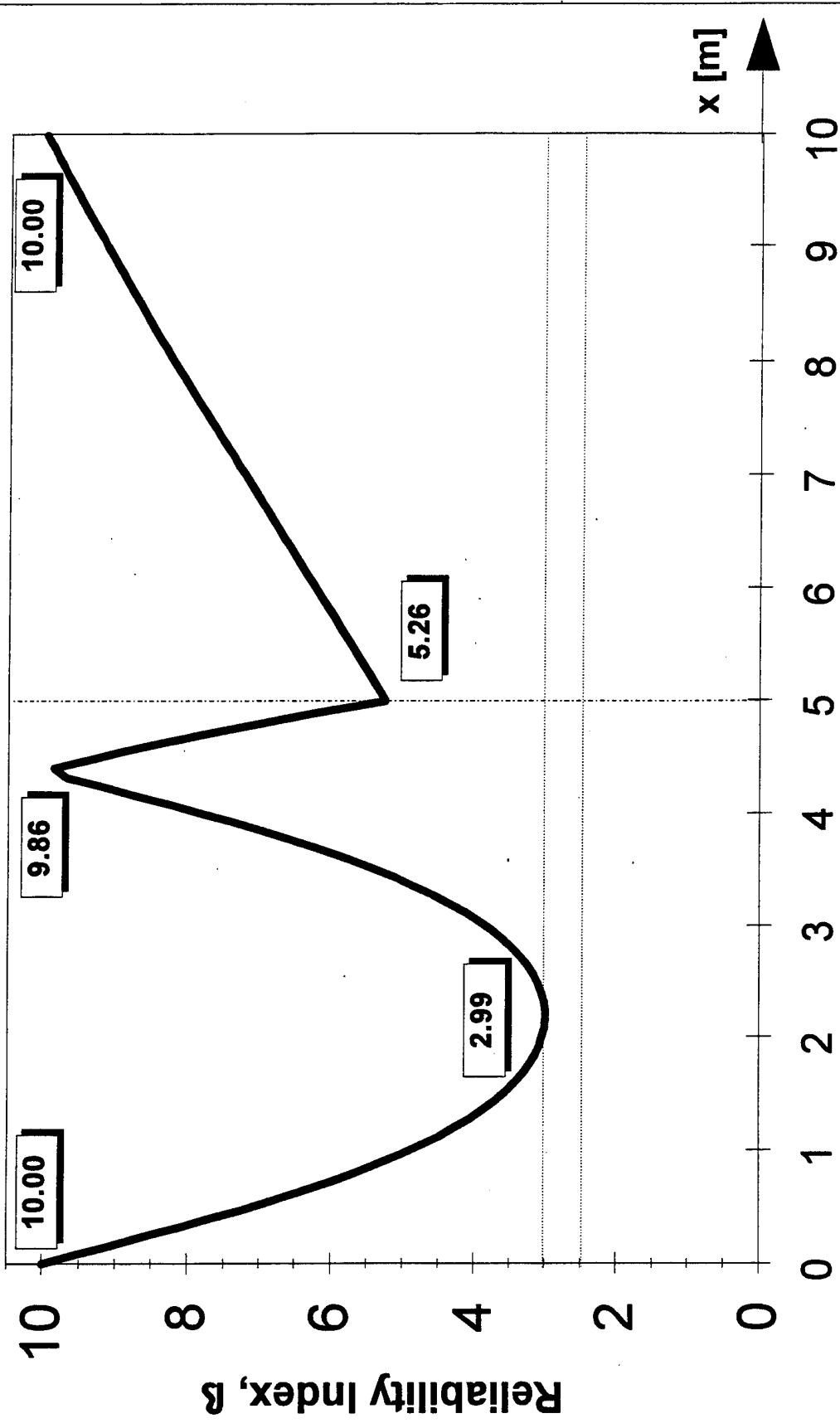

Normal

Moment Reliability Diagram

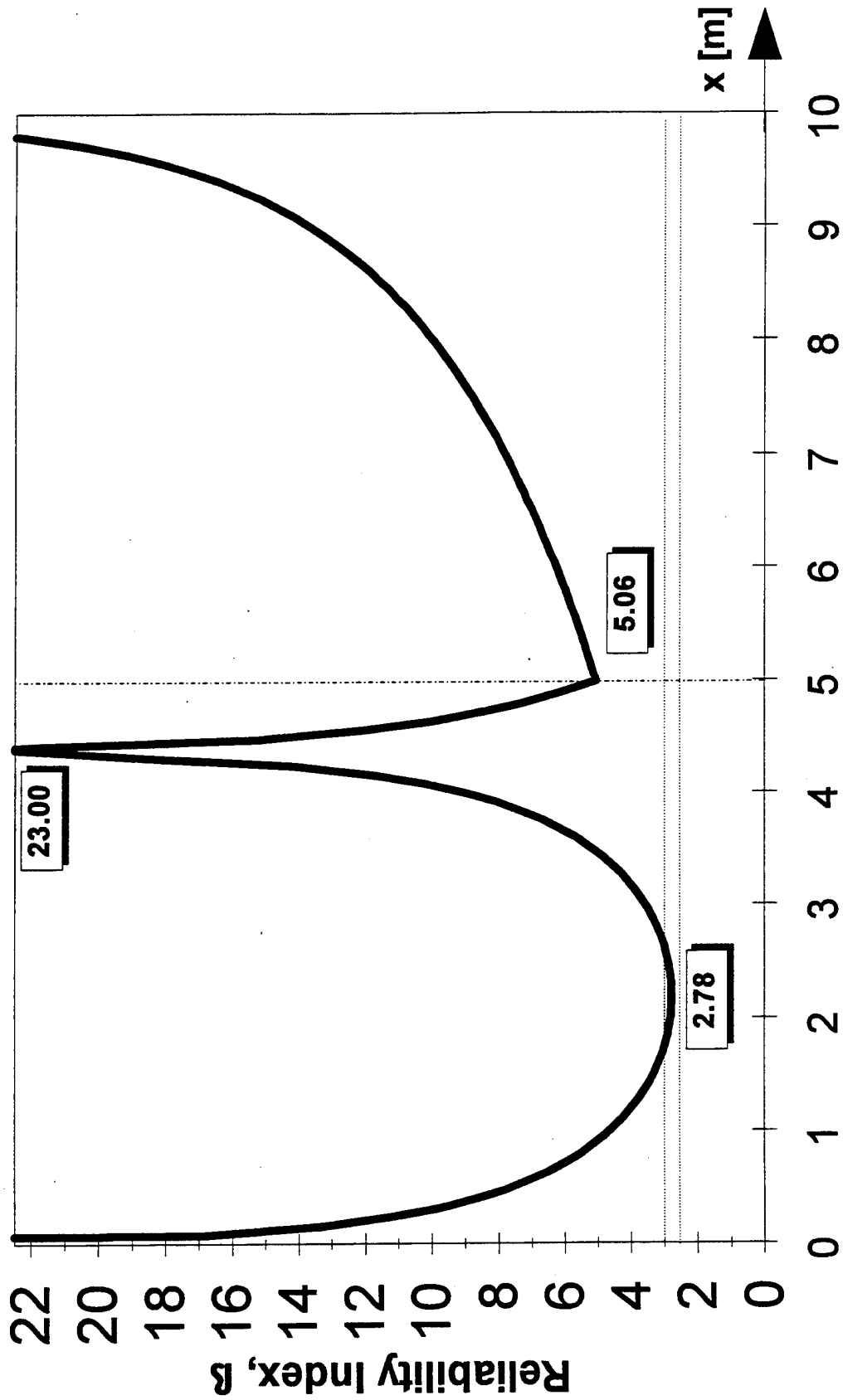

Log-Normal

Moment "Factor of Safety" Diagram

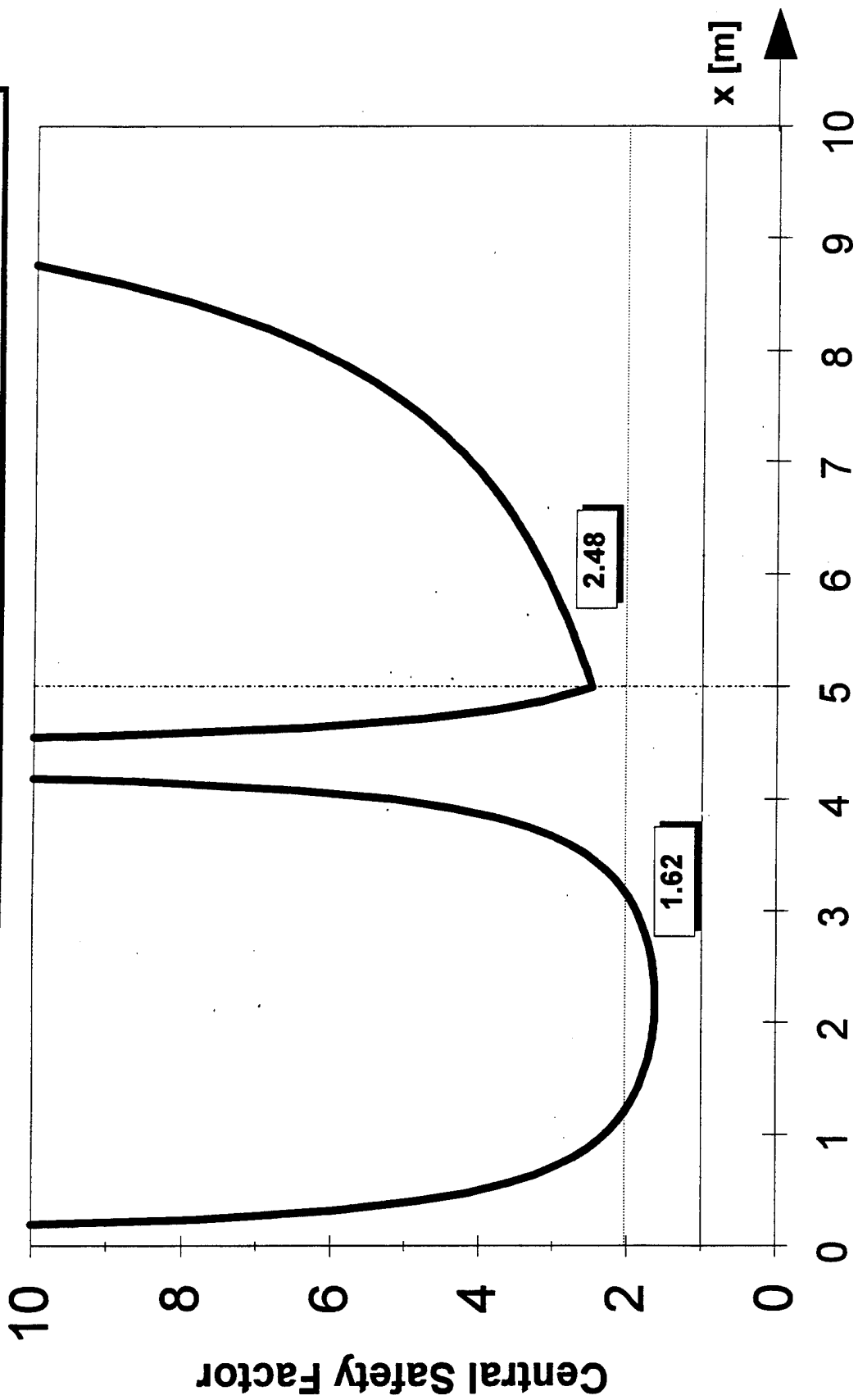

Reliability Index vs Safety Factor in Structures

Appendix B

B6

Sample System 6

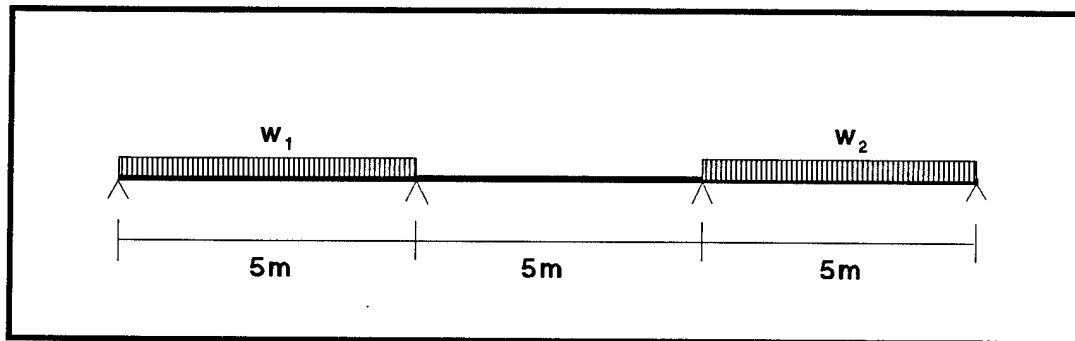

Figure 3.1f Indeterminate Beam [second degree] (AISC, p. 2-308, #35)

Contents

- 1-1 *N/A--design results only*
- 1-2 Design Step problem statement and minimum β results
- 2 Piecewise equations
- 3 Structural Analysis of Loads Diagrams
- 4 *N/A--design results only*
- 5 Design Step Reliability and Safety Factor Diagrams

SAMPLE SYSTEM 6

Simply Supported, Indeterminant (second degree) Beam

Two random, distributed loads

Uniform beam has three equal spans

Assume normal, then log-normal, distribution for load and resistance

Problem Find location of minimum reliability.

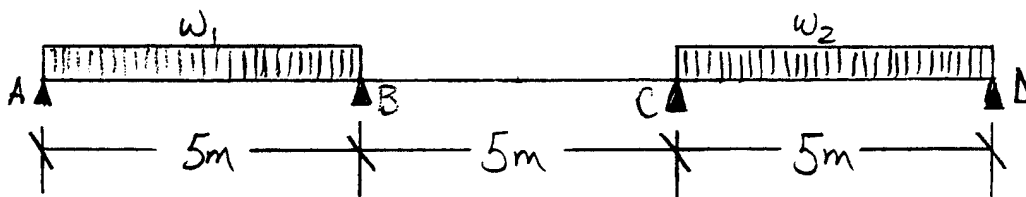

Loading

	Mean (KN/m)	C.O.V.
w1	4	15%
w2	4	10%

Load Correlation

Correlation Coefficients	Case <i>i</i>	Case <i>ii</i>
$\rho(w_1, w_2)$	0	1

Capacity

Shear: $V(R)_{\text{beam}} = 10\%$

Moment: $V(R)_{\text{beam}} = 10\%$

Sample Results

		min β	x (m)	Span	\bar{R}	\bar{S}	V(S)	Correlation
Shear (kN)	N	2.83	5.00	AB	18.00	11.00	0.15	Case <i>i</i>
	LN	2.73	5.00	AB	18.00	11.00	0.15	Case <i>i</i>
Moment (kN-m)	N	2.70	2.28	AB	16.00	10.13	0.15	Case <i>ii</i>
	LN	2.63	2.28	AB	16.00	10.13	0.15	Case <i>ii</i>

Beam System 6

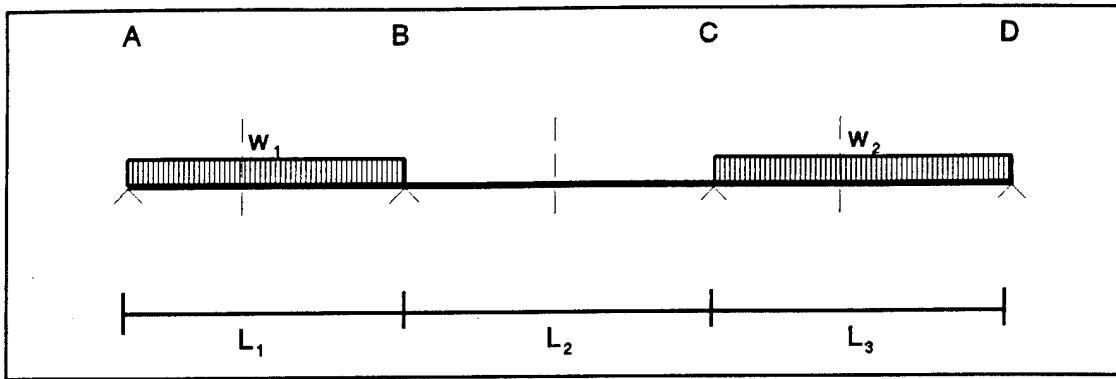

STATICS

Sum of Forces (vertical)

$$\sum F_V = 0$$

$$R_A + R_B + R_C + R_D = w_1 L_{AB} + w_3 L_{CD}$$

Sum of Moments (about point A)

$$\sum M_A = 0 - w_1 L_{AB} \left(\frac{L_{AB}}{2} \right) - R_B L_{AB} - R_C (L_{AB} + L_{BC}) + w_3 L_{CD} \left(L_{AB} + L_{BC} + \frac{L_{CD}}{2} \right) - R_D (L_{AB} + L_{BC} + L_{CD})$$

$$R_B = w_1 \left(\frac{L_{AB}}{2} \right) + w_3 \left(\frac{L_{CD}}{L_{AB}} \right) \left(L_{AB} + L_{BC} + \frac{L_{CD}}{2} \right) - R_C \left(\frac{L_{AB} + L_{BC}}{L_{AB}} \right) - R_D \left(\frac{L_{AB} + L_{BC} + L_{CD}}{L_{AB}} \right)$$

FORCE METHOD

Indeterminacy (second degree)

$$\theta_{10} + M_B \theta_{11} + M_C \theta_{12} = 0 \quad R_B = \frac{M_B}{L_{AB}}$$

$$\theta_{20} + M_B \theta_{21} + M_C \theta_{22} = 0 \quad R_C = \frac{M_C}{L_{CD}}$$

$$\theta_{10} = \frac{w_1 L_{AB}^3}{24EI}, \theta_{20} = \frac{w_3 L_{CD}^3}{24EI}, \theta_{11} = \frac{L_{AB}}{3EI} + \frac{L_{BC}}{3EI}, \theta_{21} = \frac{1}{2} \left(\frac{L_{BC}}{3EI} \right) = \theta_{21}, \theta_{22} = \frac{L_{BC}}{3EI} + \frac{L_{CD}}{3EI}$$

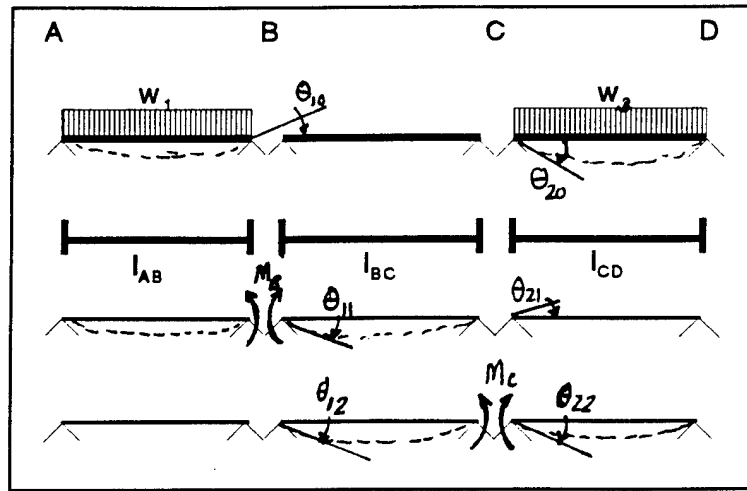

$$\frac{w_1 L_{AB}^3}{24EI} + M_B \left(\frac{L_{AB} + L_{BC}}{3EI} \right) + M_C \left(\frac{L_{BC}}{6EI} \right) = 0$$

$$\frac{w_2 L_{CD}^3}{24EI} + M_B \left(\frac{L_{BC}}{6EI} \right) + M_C \left(\frac{L_{BC} + L_{CD}}{3EI} \right) = 0$$

$$M_B = \left[\frac{-(L_{AB}^3 L_{BC} + L_{AB}^3 L_{CD})}{6L_{BC}^2 + 8L_{AB} L_{BC} + 8L_{AB} L_{CD} + 8L_{BC} L_{CD}} \right] w_1 + \left[\frac{L_{BC} L_{CD}^3}{12L_{BC}^2 + 16L_{AB} L_{BC} + 16L_{AB} L_{CD} + 16L_{BC} L_{CD}} \right] w_2$$

$$M_C = \left[\frac{-L_{AB}^3}{4L_{BC}} + \frac{L_{AB}^4 L_{BC} + L_{AB}^4 L_{CD} + L_{AB}^3 L_{BC}^2 + L_{AB}^3 L_{BC} L_{CD}}{3L_{BC}^3 + 4L_{AB} L_{BC}^2 + 4L_{AB} L_{BC} L_{CD} + 4L_{BC}^2 L_{CD}} \right] w_1 - \left[\frac{L_{AB} L_{BC} L_{CD}^3 + L_{BC}^2 L_{CD}^3}{6L_{BC}^3 + 8L_{AB} L_{BC}^2 + 8L_{AB} L_{BC} L_{CD} + 8L_{BC}^2 L_{CD}} \right] w_2$$

Reactions

$$R_A = \frac{w_1 L_{AB}}{2} + \frac{M_B}{L_{AB}}$$

$$R_A = \left[\frac{L_{AB}}{2} - \frac{(L_{AB}^3 L_{BC} + L_{AB}^3 L_{CD})}{6L_{BC}^2 + 8L_{AB} L_{BC} + 8L_{AB} L_{CD} + 8L_{BC} L_{CD}} \right] w_1 + \left[\frac{L_{BC} L_{CD}^3}{12L_{BC}^2 + 16L_{AB} L_{BC} + 16L_{AB} L_{CD} + 16L_{BC} L_{CD}} \right] w_2$$

$$\text{FORM: } R_A = \left[\frac{L_{AB}}{2} - K \right] w_1 + Q w_2$$

$$R_B = \frac{w_1 L_{AB}}{2} - \frac{M_B}{L_{AB}}$$

$$R_B = \left[\frac{L_{AB}}{2} + \frac{(L_{AB}^3 L_{BC} + L_{AB}^3 L_{CD})}{6L_{BC}^2 + 8L_{AB}L_{BC} + 8L_{AB}L_{CD} + 8L_{BC}L_{CD}} \right] w_1$$

$$- \left[\frac{L_{BC}L_{CD}^3}{12L_{BC}^2 + 16L_{AB}L_{BC} + 16L_{AB}L_{CD} + 16L_{BC}L_{CD}} \right] w_3$$

$$FORM: R_B = \left[\frac{L_{AB}}{2} + K \right] w_1 - Q w_3$$

$$R_C = \frac{w_3 L_{CD}}{2} - \frac{M_C}{L_{CD}}$$

$$R_C = \left[\frac{L_{AB}^3}{4L_{BC}L_{BC}} - \frac{L_{AB}^4 L_{BC} + L_{AB}^4 L_{CD} + L_{AB}^3 L_{BC}^2 + L_{AB}^3 L_{BC}L_{CD}}{3L_{BC}^3 + 4L_{AB}L_{BC}^2 + 4L_{AB}L_{BC}L_{CD} + 4L_{BC}^2 L_{CD}} \right] w_1$$

$$+ \left[\frac{L_{CD}}{2} - \frac{L_{AB}L_{BC}L_{CD}^3 + L_{BC}^2 L_{CD}^3}{6L_{BC}^3 + 8L_{AB}L_{BC}^2 + 8L_{AB}L_{BC}L_{CD} + 8L_{BC}^2 L_{CD}} \right] w_3$$

$$FORM: R_C = \left[\frac{L_{AB}^3}{4L_{BC}L_{BC}} - J \right] w_1 + \left[\frac{L_{CD}}{2} + T \right] w_3$$

$$R_D = \frac{w_3 L_{CD}}{2} + \frac{M_C}{L_{CD}}$$

$$R_D = \left[\frac{-L_{AB}^3}{4L_{BC}L_{BC}} + \frac{L_{AB}^4 L_{BC} + L_{AB}^4 L_{CD} + L_{AB}^3 L_{BC}^2 + L_{AB}^3 L_{BC}L_{CD}}{3L_{BC}^3 + 4L_{AB}L_{BC}^2 + 4L_{AB}L_{BC}L_{CD} + 4L_{BC}^2 L_{CD}} \right] w_1$$

$$+ \left[\frac{L_{CD}}{2} + \frac{L_{AB}L_{BC}L_{CD}^3 + L_{BC}^2 L_{CD}^3}{6L_{BC}^3 + 8L_{AB}L_{BC}^2 + 8L_{AB}L_{BC}L_{CD} + 8L_{BC}^2 L_{CD}} \right] w_3$$

$$FORM: R_D = \left[\frac{-L_{AB}^3}{4L_{BC}L_{BC}} + J \right] w_1 + \left[\frac{L_{CD}}{2} - T \right] w_3$$

Segment AB

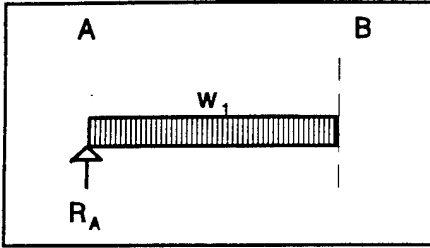

Shear

$$V = R_A - w_1 x$$

$$V = \left[\frac{L_{AB}}{2} - K - x \right] w_1 + Q w_3$$

Shear Dispersion

$$\sigma_{S_V}^2 = \left[\frac{L_{AB}}{2} - K - x \right]^2 \sigma_{w_1}^2 + Q^2 \sigma_{w_3}^2 + 2\rho_{w_1 w_3} \left[\frac{L_{AB}}{2} - K - x \right] Q \sigma_{w_1} \sigma_{w_3}$$

Moment

$$M = R_A x - \frac{x^2}{2} w_1$$

$$M = \left[\left(\frac{L_{AB}}{2} - K \right) x - \frac{x^2}{2} \right] w_1 + (Qx) w_3$$

Moment Dispersion

$$\sigma_{S_M}^2 = \left[\left(\frac{L_{AB}}{2} - K \right) x - \frac{x^2}{2} \right]^2 \sigma_{w_1}^2 + (Qx)^2 \sigma_{w_3}^2 + 2\rho_{w_1 w_3} \left[\left(\frac{L_{AB}}{2} - K \right) x - \frac{x^2}{2} \right] (Qx) \sigma_{w_1} \sigma_{w_3}$$

Segment BC

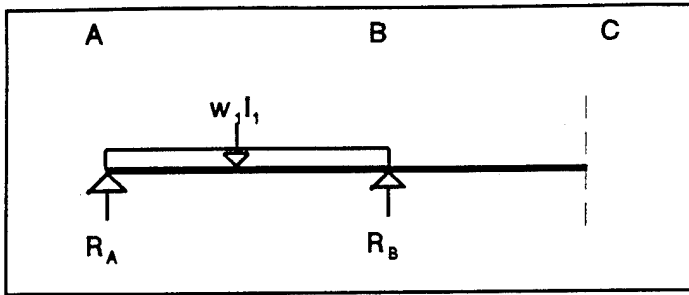

Shear

$$V = R_A - w_1 x + R_B$$

$$V = \left[\frac{L_{AB}}{2} - K \right] w_1 + Q w_3 - w_1 L_{AB} + \left[\frac{L_{AB}}{2} + K \right] w_1 - Q w_3 = 0$$

Shear Dispersion

$$\sigma_{S_V}^2 = 0$$

Moment

$$M = R_A x - w_1 L_{AB} \left(x - \frac{L_{AB}}{2} \right) + R_B (x - L_{AB})$$

$$M = -K L_{AB} w_1 + Q L_{AB} w_3$$

Moment Dispersion

$$\sigma_{S_M}^2 = (K L_{AB})^2 \sigma_{w_1}^2 + (Q L_{AB})^2 \sigma_{w_3}^2 + 2 \rho_{w_1 w_3} K Q L_{AB}^2 \sigma_{w_1} \sigma_{w_3}$$

Segment CD

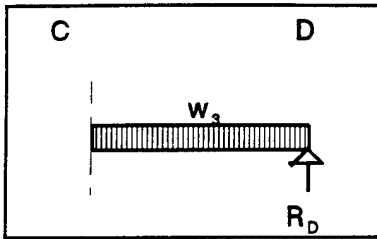

Shear

$$V = \left(\frac{L_{AB}^3}{4L_{BC}L_{CD}} - J \right) w_1 + \left(T + L_{AB} + L_{BC} + \frac{L_{CD}}{2} - x \right) w_3$$

Shear Dispersion

$$\begin{aligned} \sigma_{S_V}^2 = & \left(\frac{L_{AB}^3}{4L_{BC}L_{CD}} - J \right)^2 \sigma_{w_1}^2 + \left(T + L_{AB} + L_{BC} + \frac{L_{CD}}{2} - x \right)^2 \sigma_{w_3}^2 \\ & + 2\rho_{w_1 w_3} \left(\frac{L_{AB}^3}{4L_{BC}L_{CD}} - J \right) \left(T + L_{AB} + L_{BC} + \frac{L_{CD}}{2} - x \right) \sigma_{w_1} \sigma_{w_3} \end{aligned}$$

Moment

$$M = \left[\left(\frac{-L_{AB}^3}{4L_{BC}L_{CD}} + J \right) (L_{AB} + L_{BC} + L_{CD} - x) \right] w_1 + \left[\left(\frac{L_{CD}}{2} - T \right) (L_{AB} + L_{BC} + L_{CD} - x) - \frac{(L_{AB} + L_{BC} + L_{CD} - x)^2}{2} \right] w_3$$

Moment Dispersion

$$\begin{aligned} \sigma_{S_M}^2 = & \left[\left(\frac{-L_{AB}^3}{4L_{BC}L_{CD}} + J \right) (L_{AB} + L_{BC} + L_{CD} - x) \right]^2 \sigma_{w_1}^2 + \left[\left(\frac{L_{CD}}{2} - T \right) (L_{AB} + L_{BC} + L_{CD} - x) - \frac{(L_{AB} + L_{BC} + L_{CD} - x)^2}{2} \right]^2 \sigma_{w_3}^2 \\ & + 2\rho_{w_1 w_3} \left[\left(\frac{-L_{AB}^3}{4L_{BC}L_{CD}} + J \right) (L_{AB} + L_{BC} + L_{CD} - x) \right] \left[\left(\frac{L_{CD}}{2} - T \right) (L_{AB} + L_{BC} + L_{CD} - x) - \frac{(L_{AB} + L_{BC} + L_{CD} - x)^2}{2} \right] \sigma_{w_1} \sigma_{w_3} \end{aligned}$$

Shear Diagram

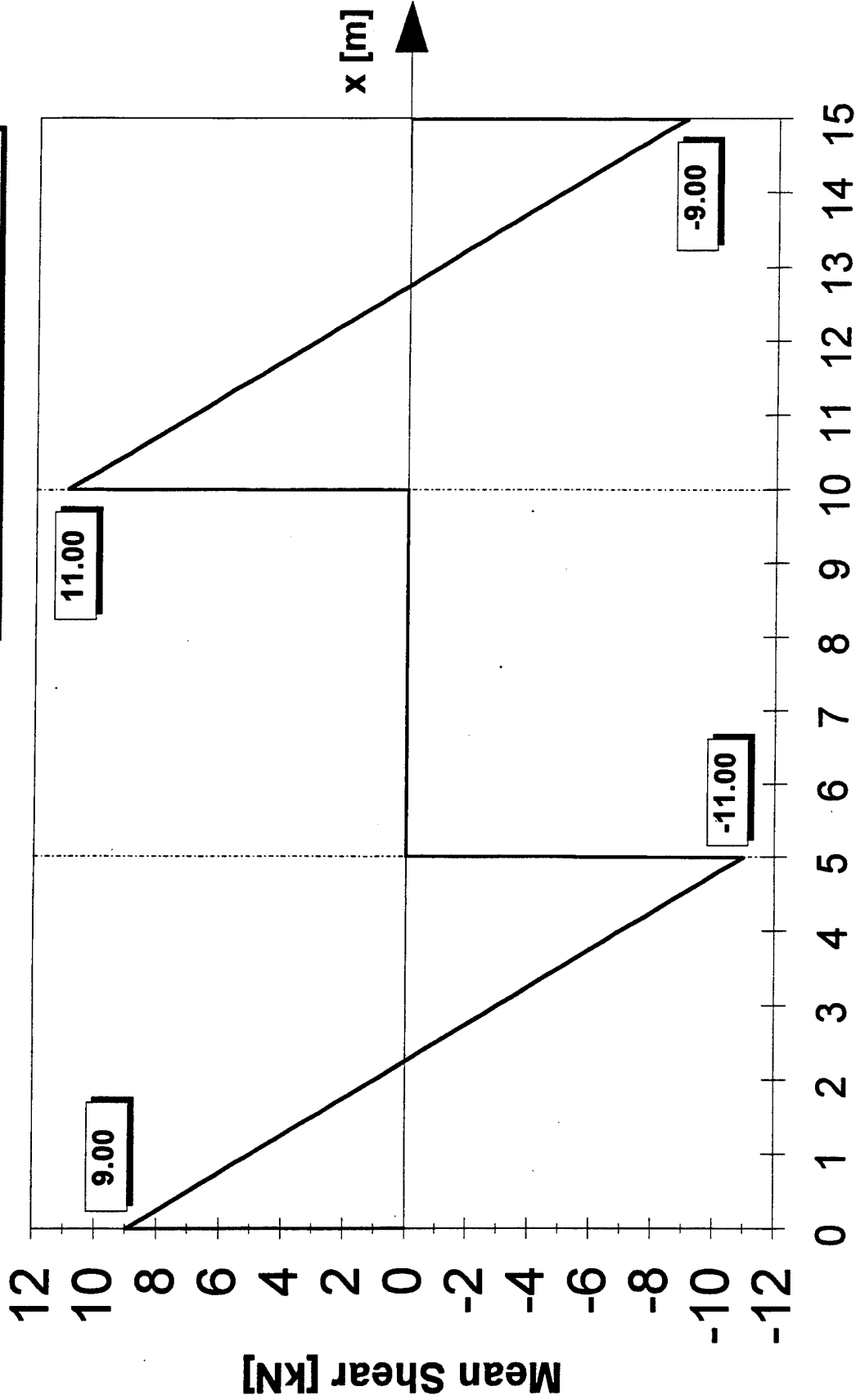

Shear Dispersion Diagram

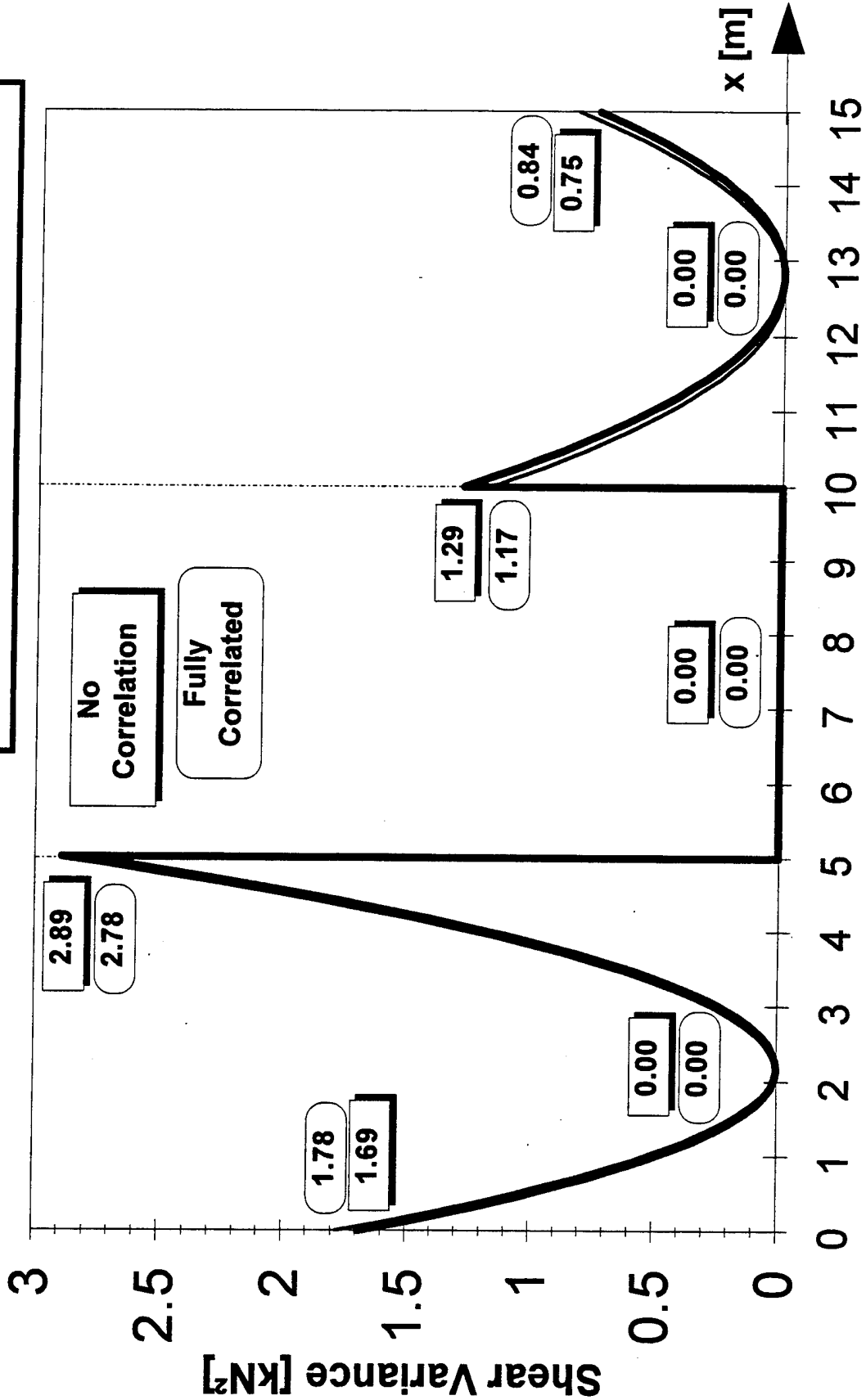

Moment Diagram

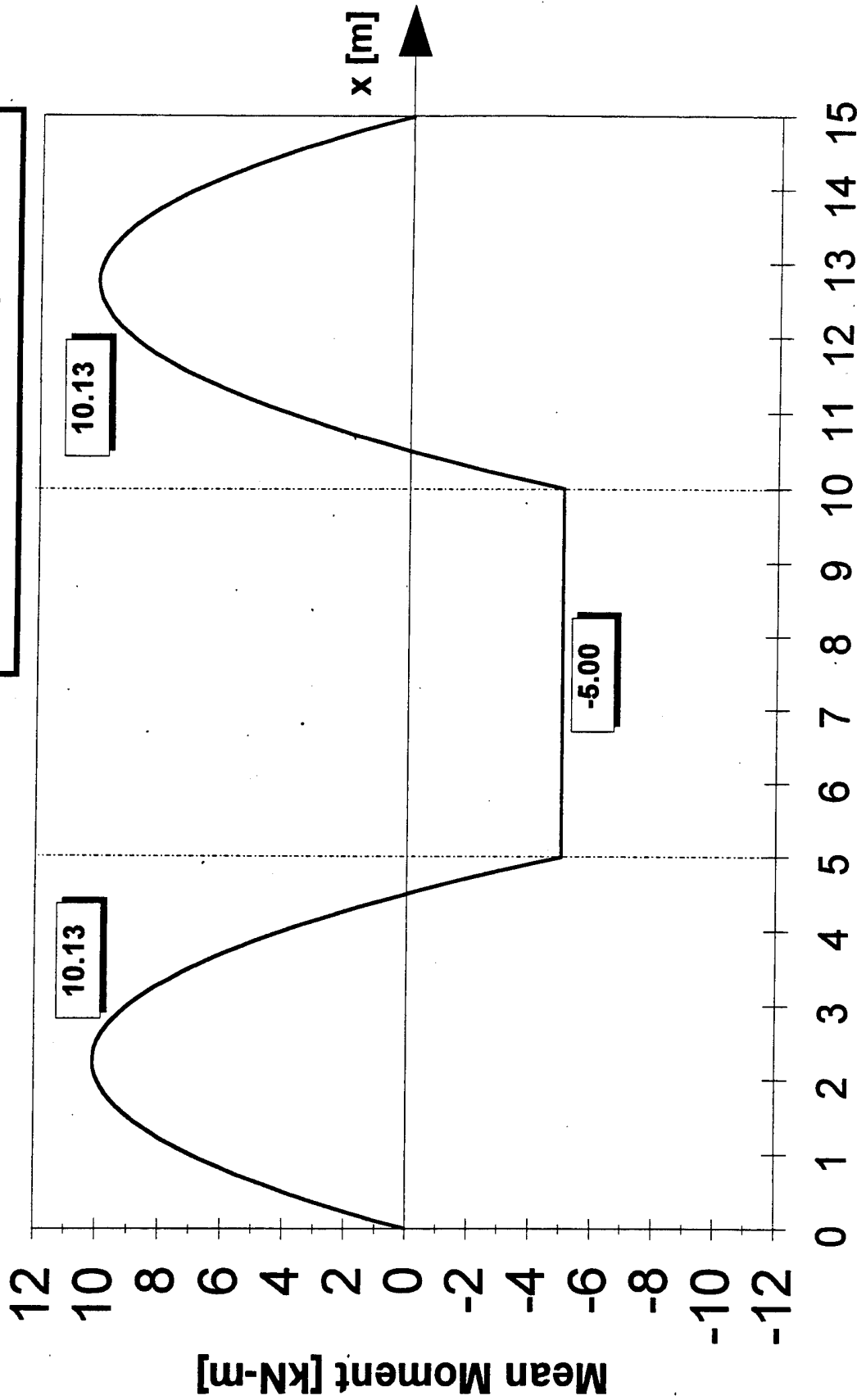

Moment Dispersion Diagram

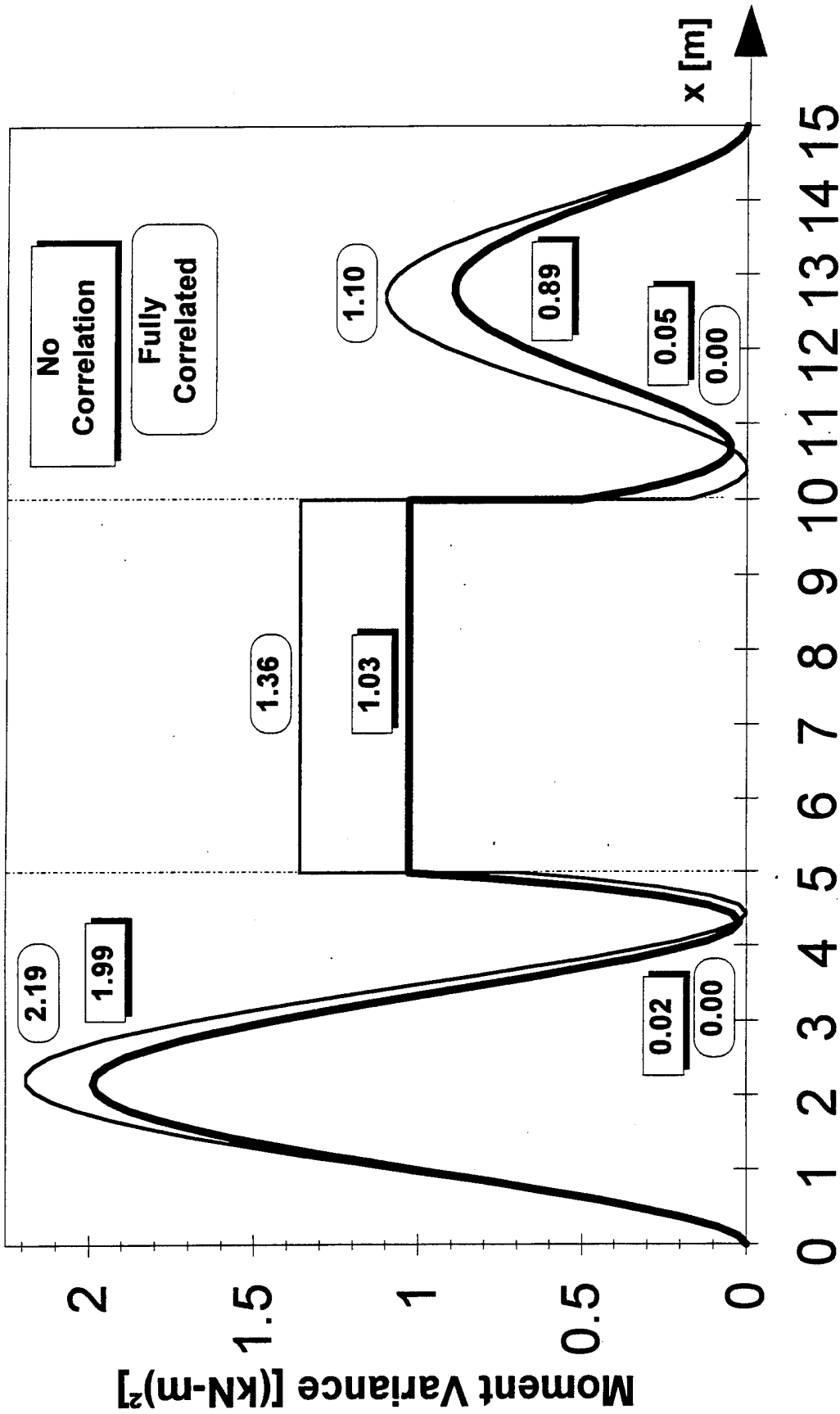

Shear Reliability Diagram

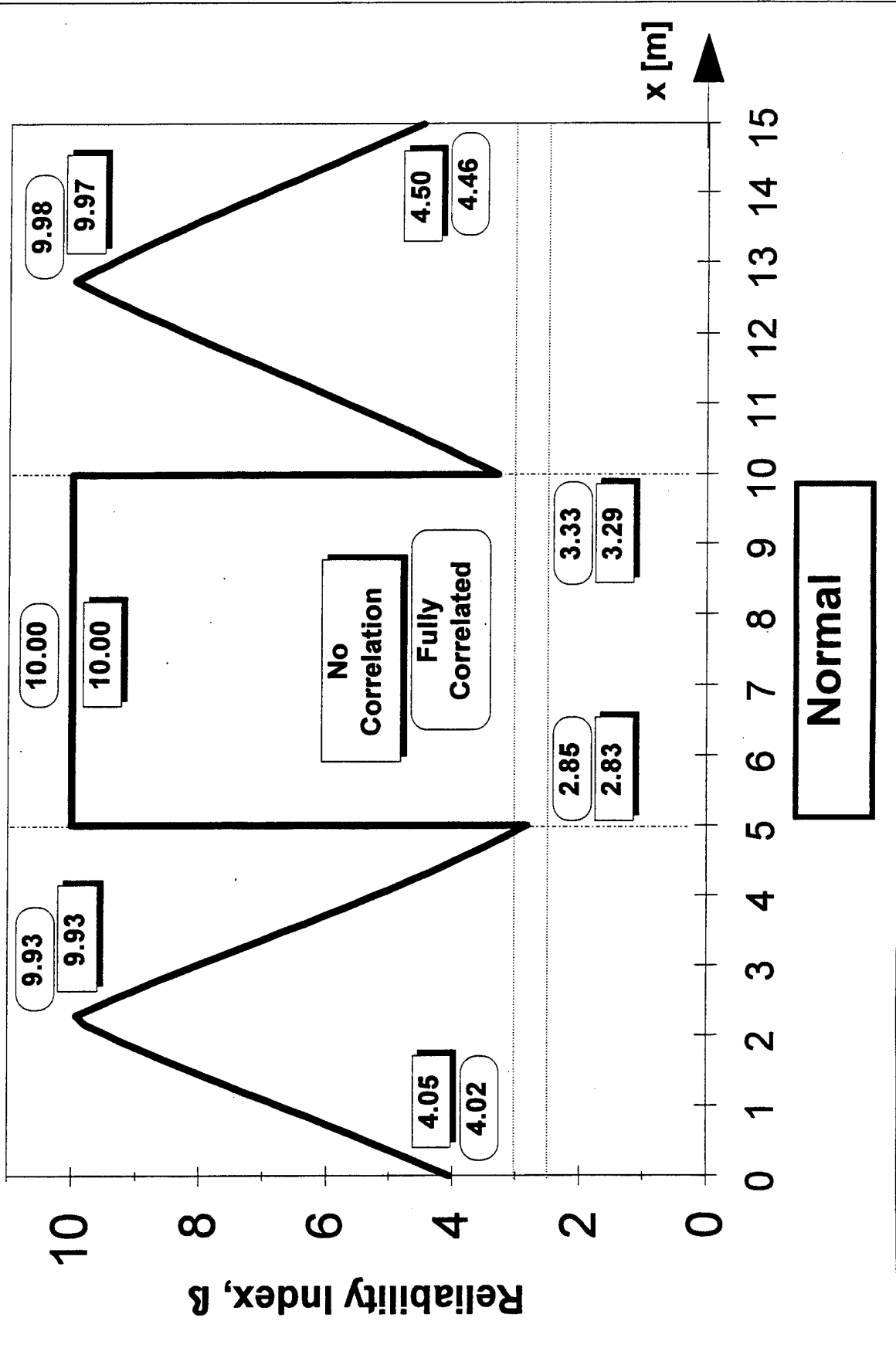

Shear Reliability Diagram

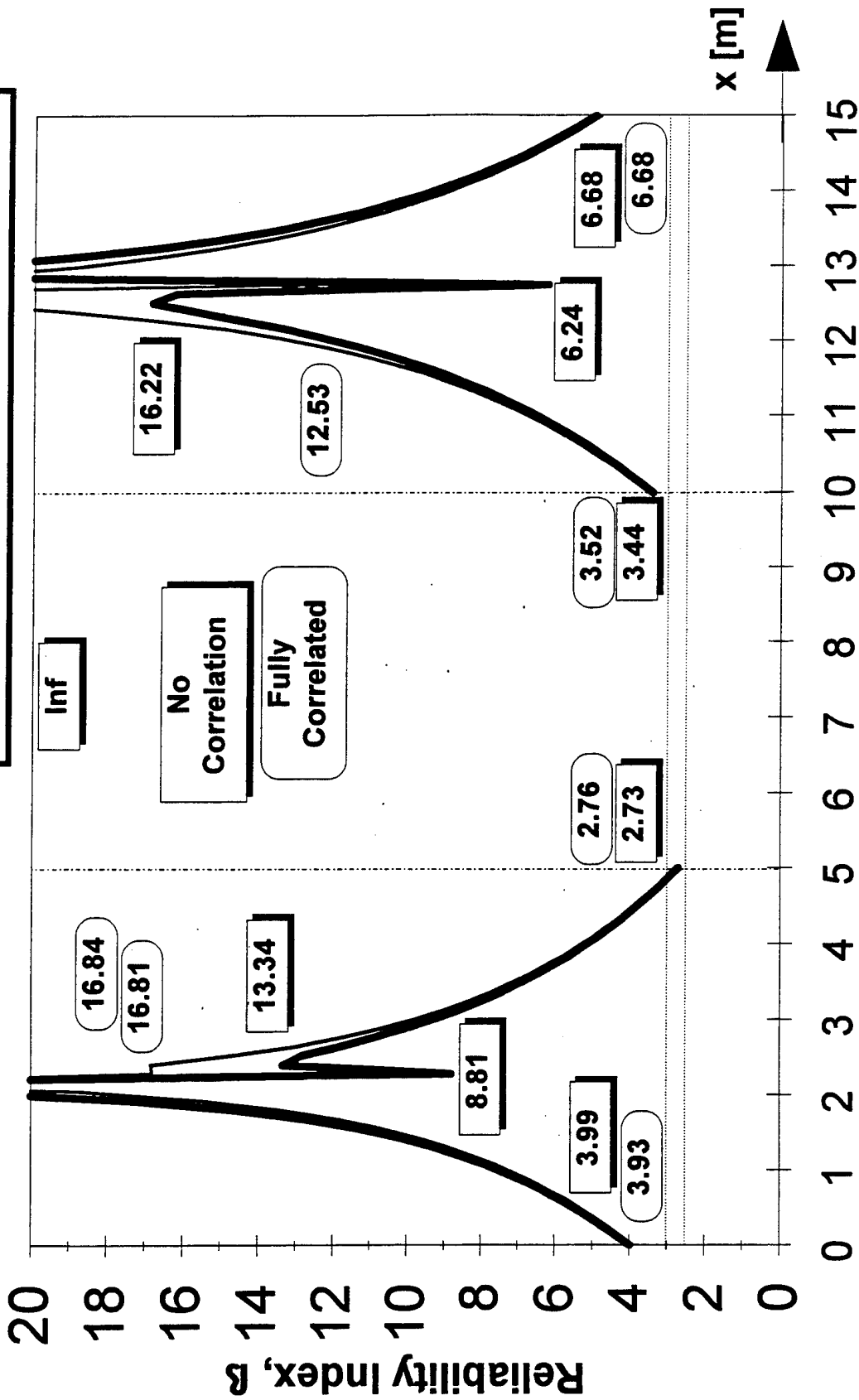

Shear "Factor of Safety" Diagram

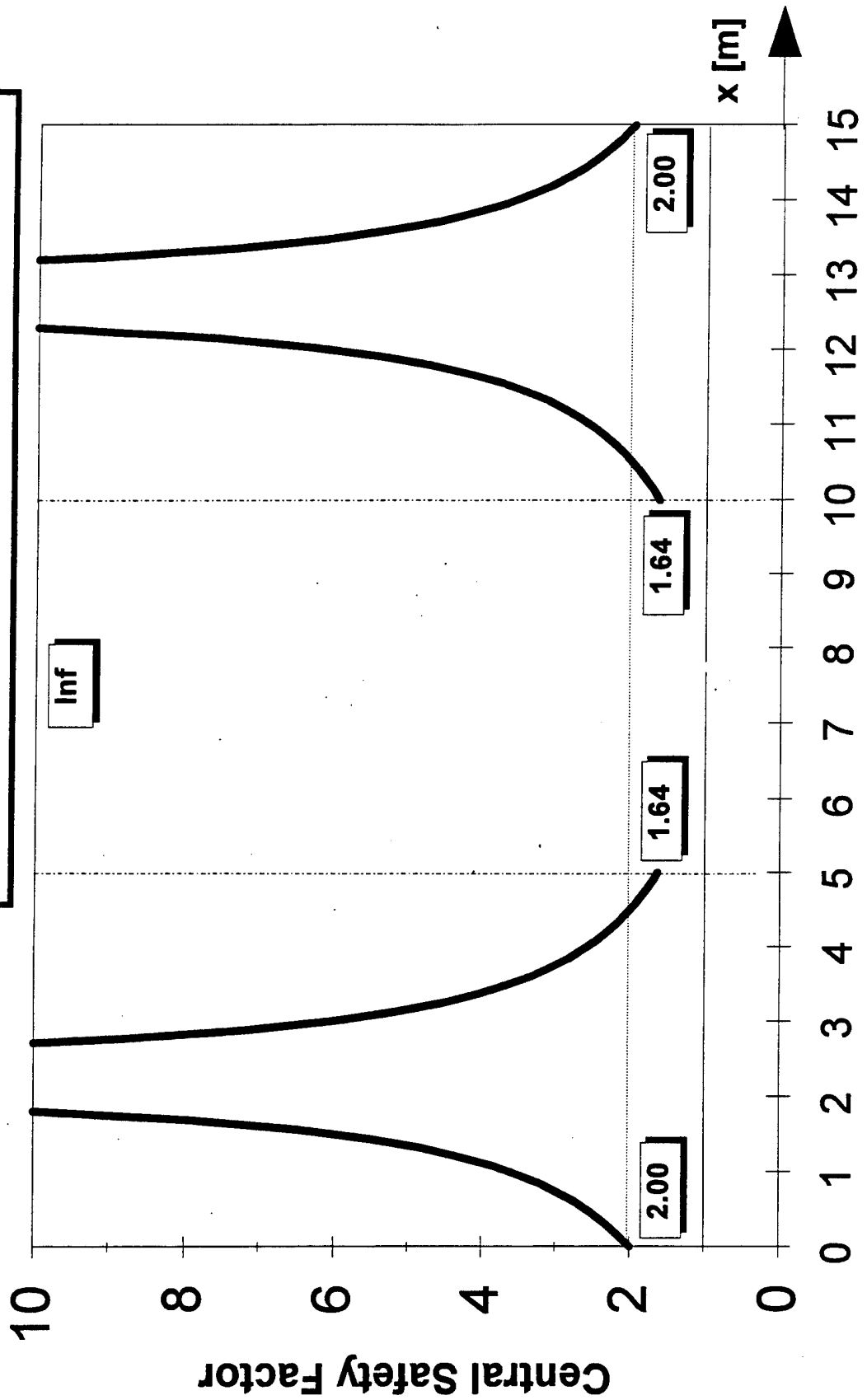

Moment Reliability Diagram

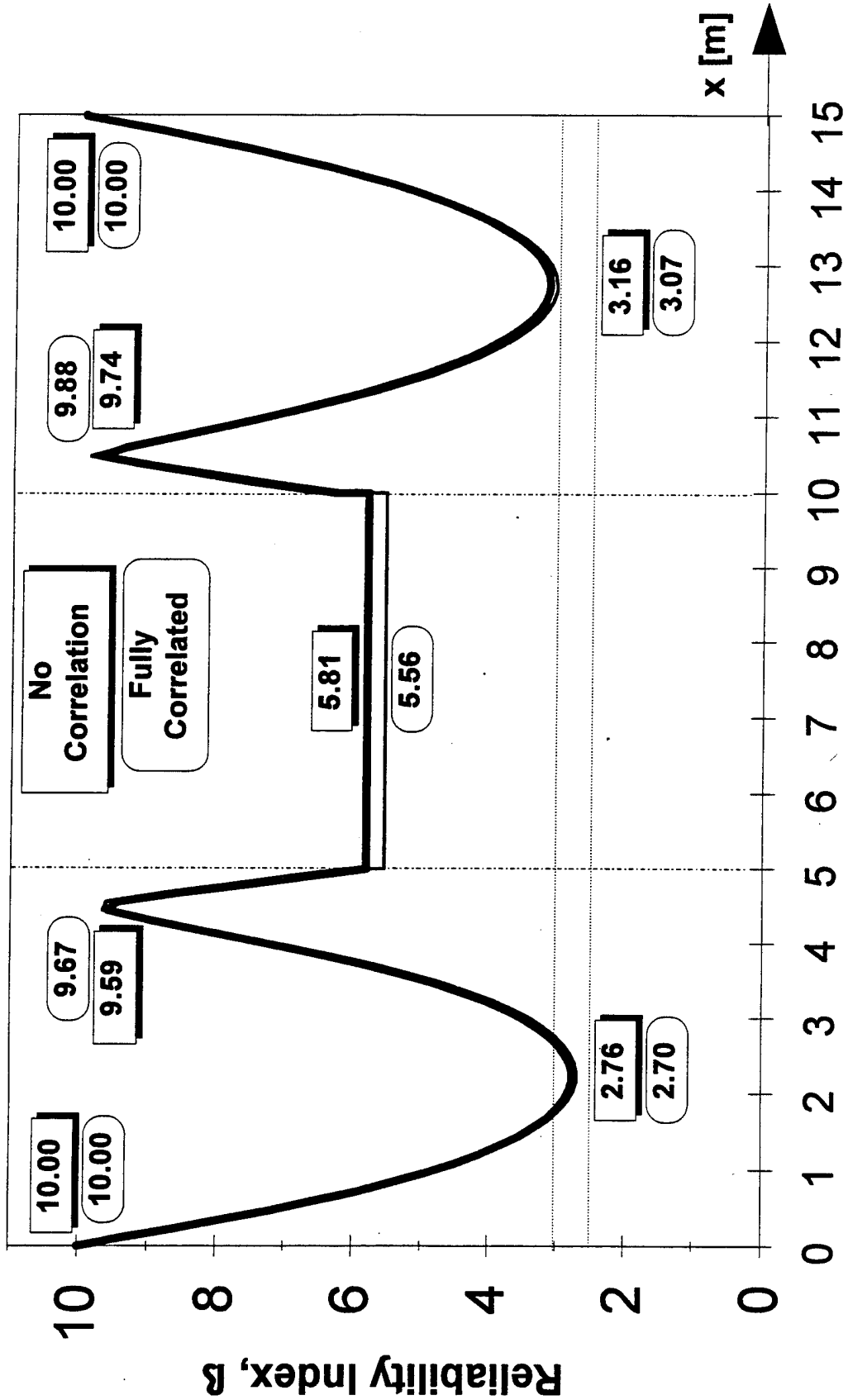

Normal

Moment Reliability Diagram

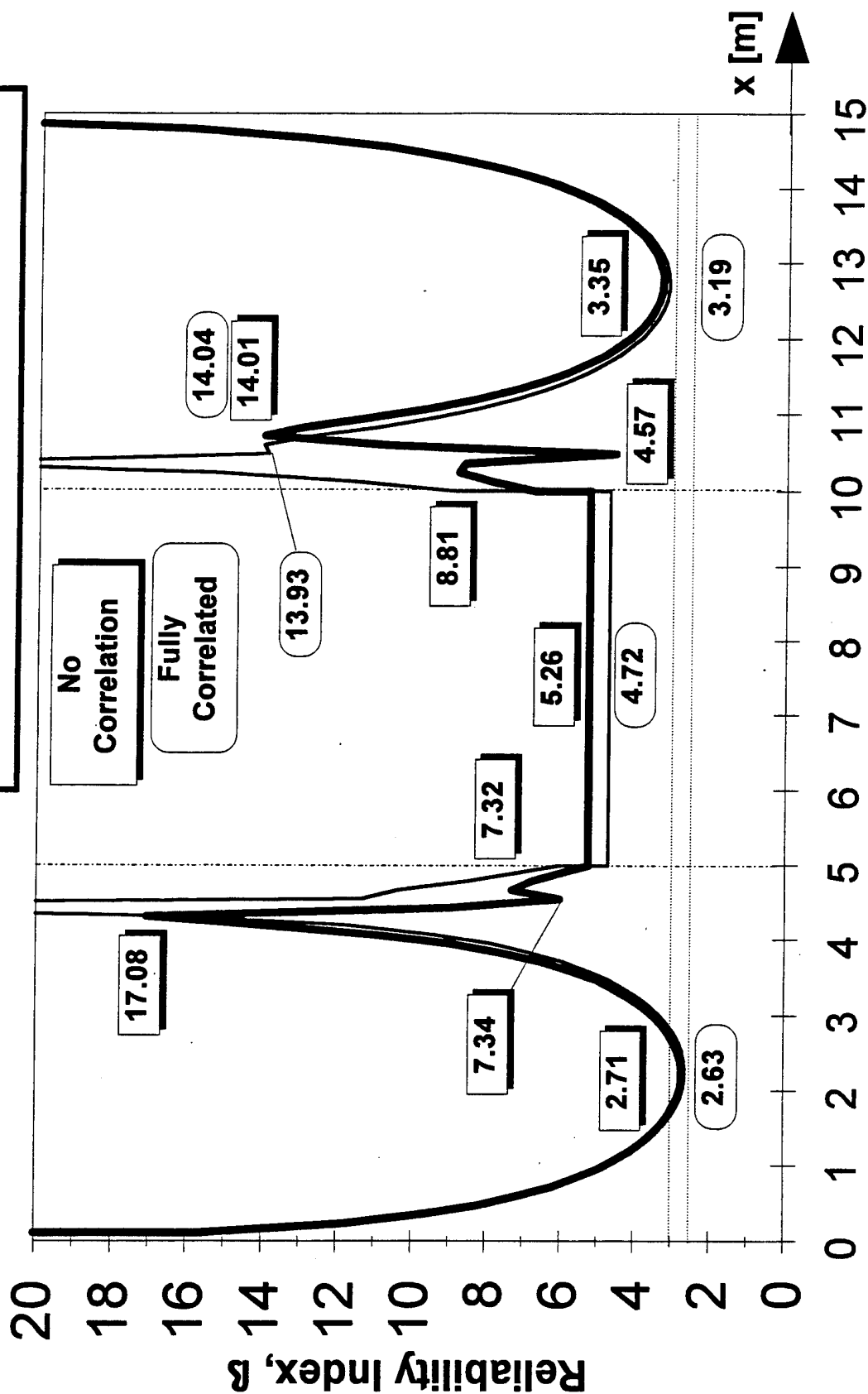

Log-Normal

Moment "Factor of Safety" Diagram

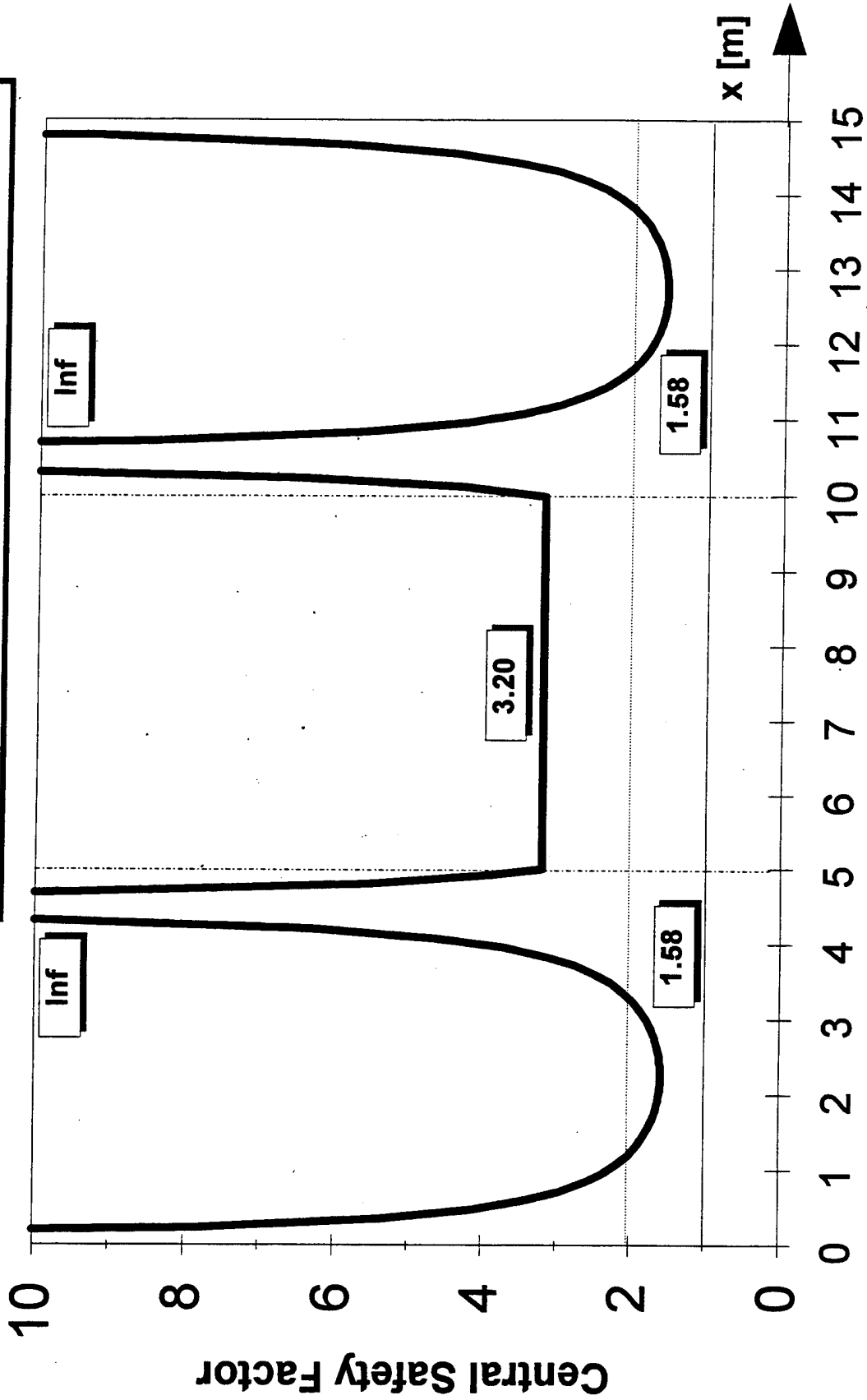

Reliability Index versus Safety Factor of Structures

Appendix C

Masters of Science COMPREHENSIVE EXAM QUESTIONS

Spring 1995

SECTION C1

Response to Dr. Gerstle
Investigate Plastic Behavior
on
Safety Factor & Reliability Index

SECTION C2

Response to Dr. Spacone
Summarize Structural Effects
of
Semi-Rigid Connections

The analyses presented in your report are based entirely on elastic analysis. As you point out in Sec. 5.2 of your report, an alternate approach would be a collapse (plastic, or limit-analysis) analysis, assuming sufficient ductility in the structure. Additional load-carrying capacity would be predicted by redistribution of forces within the structure.

You are to investigate the effect of this behavior on the safety factor and reliability index with respect to collapse, with specific reference to your Sample System 5, Appendix B.

You might consider preceding in these steps. (These are included at their respective item)

Response to Dr. Gerstle's Questions

Calculating the plastic capacity and reliability of a beam requires more than simple statics. It also requires a selected cross section; this report was more concerned with defining the effects load placement has on reliability. With that this section investigates the effect of plastic behavior on reliability. Beginning from a *basic* perspective for plastic capacity, this describes the full plastic moment capacity for **Beam System 5**--

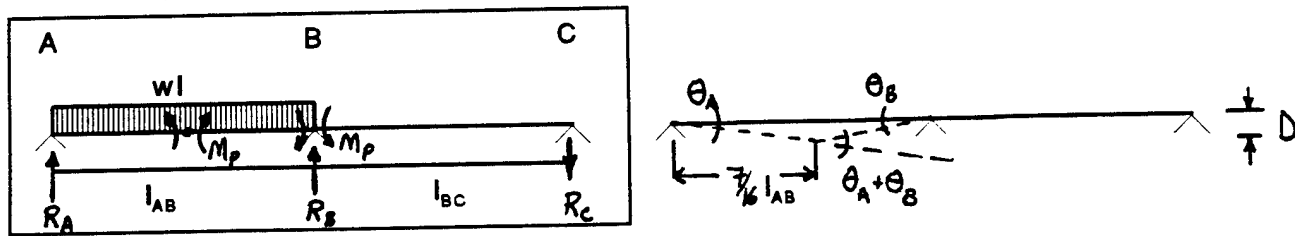

STATICS

Sum of Forces (vertical)

$$\sum F_V = 0$$

$$R_A + R_B - R_C = w_{AB} L_{AB}$$

Calculation of full plastic moment relative to the applied load

$$BC - R_C L_{BC} = M_p \quad R_C = 0.2 M_p$$

$$A'C - R_B \left(\frac{9}{16} L_{AB} \right) - R_C \left(\frac{9}{16} L_{AB} + L_{BC} \right) = M_p \quad R_B = 0.911 M_p$$

$$AB - R_A \left(\frac{7}{16} L_{AB} \right) = M_p \quad R_A = 0.457 M_p$$

(White, p 330)

SO--

$$\begin{aligned}
 w_{AB} L_{AB} &= 1.168 M_P \\
 (w_{AB})_{cr} &= 0.234 M_P \\
 (w_{AB})_{cr} &= 0.234 Z f_y
 \end{aligned}$$

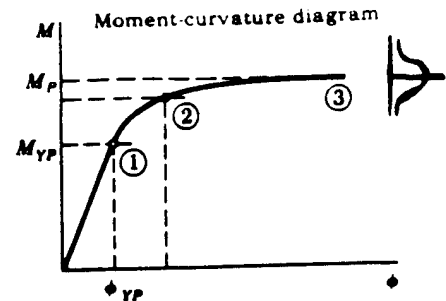

(Gerstle: Design, Figure 7.3d, p. 223)

Part 1. Considering only deterministic load and resistance, find the plastic load-carrying capacity. Describe the additional information needed for this analysis, and give a description of it.

A plastic analysis first requires an actual cross section. The plastic moment, M_P , is a function of the shape factor, f , as shown below--

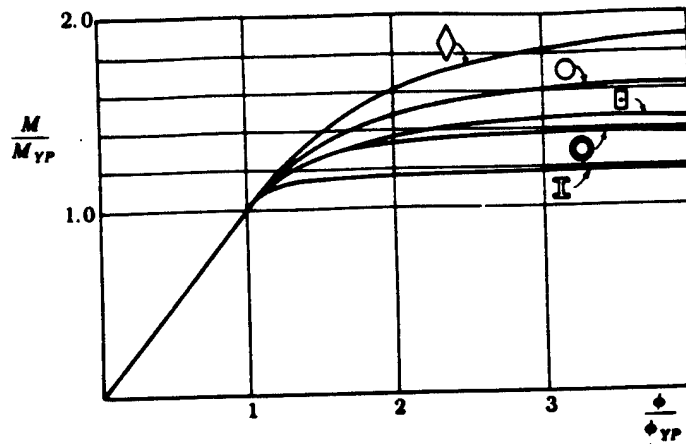

Shape Factor (f): Moment-Curvature Diagram (Gerstle: Design, Fig 7.5, p. 225)

The beam exists in three stages--elastic, elasto-plastic, and plastic, illustrated with diagrams from White, p. 329, Gerstle, p. 223, and Ugural, p. 384. This example nearly emulates the moment behavior of a distributed load (refer to Appendix B5.3-3).

Elastic Behavior: Stress to first yielding--

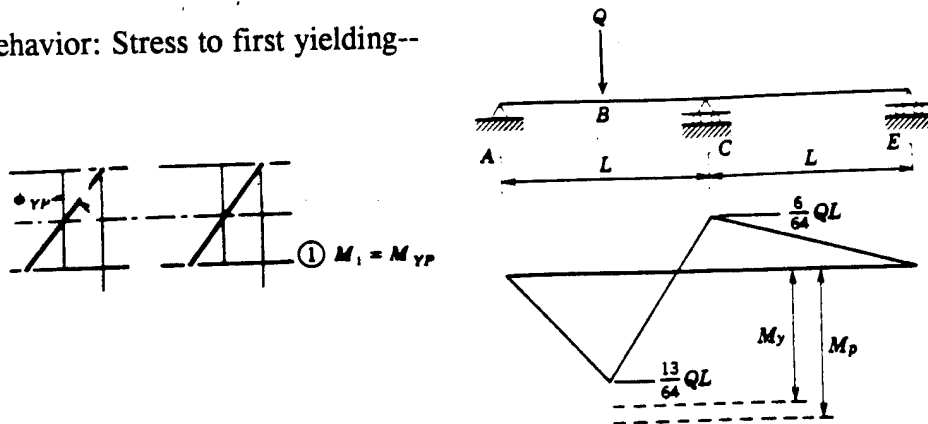

(Gerstle: Design, Figure 7.3a, p. 223)

(White, Figure 24.11a&b, p. 329 Vol 3)

Elasto-Plastic Behavior: Onset of first plastic hinge--

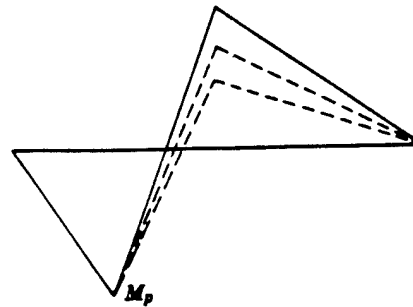
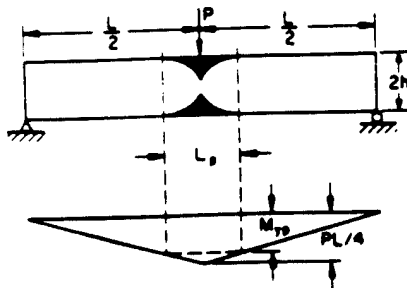
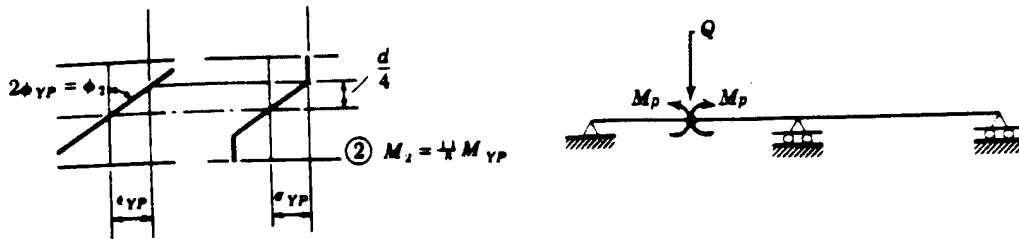

(Gerstle: Design, Figure 7.3b, p. 223)
 (White, Figure 24.11c&d, p. 329 Vol 3)
 (Ugural, 12.6a&b, p. 384)

Plastic Behavior: Full development of collapse mode--

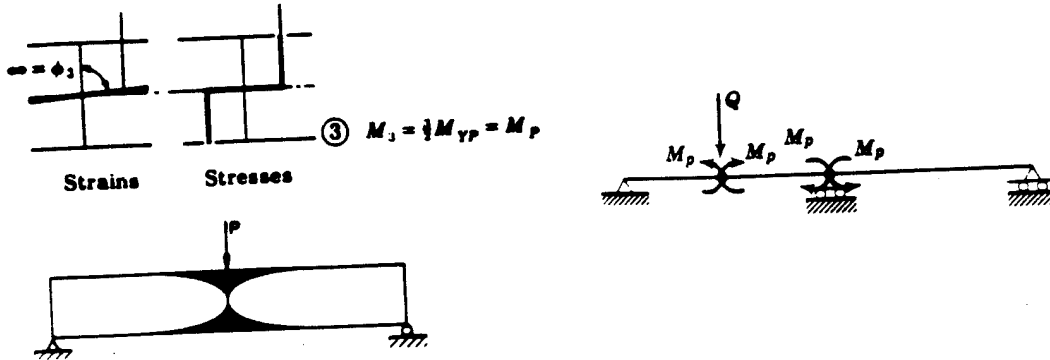

(Gerstle: Design, Figure 7.3c, p. 223)
 (White, Figure 24.11e, p. 329 Vol 3)
 (Ugural, 12.6c, p. 384)

This indeterminate (first degree) beam need two plastic hinges to collapse. If load increases past the yield load, the first plastic hinge occurs left of the mid span of segment AB--here $M_{YP} = f_y S$ and $M_p = f S f_y$. These dual hinge calculations assume a rectangular cross section.

As discussed before, shear is a brittle failure. From Beer, p. 242, $\tau \approx 1.5 V/A$; per Ugural, p. 118, and the Maximum Shearing Stress Theory, $\tau_y = 0.5 f_y$. Additionally, for mild steel, Figure 2.1 in Ugural (p. 50) shows $\tau_{ult} \approx 2 \tau_y \approx f_y$.

The *additional information needed* would be--

Shape of beam;

Actual yield strength of material in shear and moment, along with variance.

The provisions in the PBLSD *design step* of the report lets the engineer select the smallest beam for the load (demand). Presumably, this selection relies entirely on elastic properties for its primary strength.

Probabilistically, M_p is a function of shape, segment lengths, yield stress, and the plastic modulus (shape). Variance is a function of the same, but mostly it should remain at the same value-- $V(R)$ = assumed elastic range value.

Part 2. Apply the probabilistic concepts which you have developed in your report to the determination of the reliability index against plastic collapse.

Probabilistically, actual load effects are independent from capacity, even though the critical load is used to define the limit state. \bar{S} and σ_s remain the same in the reliability index model. Presumably, $V(R)$ remains the same, so only the plastic capacity mean value changes. If illustrated on a bivariate model, as presented in Figure 1.1, the plastic capacity curve would be identical to the elastic mean value curve, only placed to the right (further from the origin). Expectedly, $\beta_{\text{limit state}}$ would be higher than $\beta_{\text{elastic (yield)}}$, and higher than the $\beta_{\text{elastic (sub-yield)}}$ values shown in Appendix B5.

Part 3. Relate section strength in bending and shear to the values \bar{R} given in the table on Page B5.1 of your report, and compute safety factor and reliability index for this case.

As stated before loads were deliberately kept low to simplify graphics. Selecting a section-- $b=5$ cm and $d=15$ cm (essentially a rectangular rod), or--

$$\begin{aligned} A &= 0.0075 \text{ m}^2, \\ I &= 0.000014 \text{ m}^4, \text{ and} \\ S &= 0.00019 \text{ m}^3. \end{aligned}$$

Agreeably, this a ridiculously small member, but must be so to counter the tiny loads. From before--

$$\begin{aligned} w_{AB} &= 4 \text{ kN/m with } V(S) = 15\% \\ &\text{with } L_{AB} = 5\text{m and } L_{BC} = 5\text{m.} \end{aligned}$$

F_y for steel is (36 ksi) 248211 kN/m². From the Maximum Shearing Stress Theory, for normal variates (Appendix B5.1 uses $V(R) = 10\%$)--

$$\begin{aligned} V_{YP} &= 620 \text{ kN, } M_{YP} = 46.5 \text{ kNm; and} \\ V_{ult} &= 1241 \text{ kN, } M_p = 69.8 \text{ kNm.} \end{aligned}$$

		\bar{R}	\bar{S}	$\beta_{\text{limit state}}$	θ_0
Shear (kN)	<i>Yield</i>	620	11.25	5.82	55.11
	<i>Ultimate</i>	1241	11.25	9.92	110.31
Moment (kNm)	<i>Yield</i>	46.5	9.57	7.59	4.86
	<i>Plastic Collapse</i>	69.8	9.57	8.45	7.29

Shear appears to be the controlling yielding mode. Moment appears to be the collapse mode.

Part 4. Compare results of Sample System 5 in your report and the results of Step 3, above. Discuss values provided versus values required. Comment on the relative advantages and disadvantages of both limit state approaches, considering relation to the real structure under overload, simplicity of concept and execution, and any other relevant aspects.

Comparing these values with those given in Appendix B5.1, with--

$$\text{Shear: } \beta_{\text{elastic (sub-yield)}} = 2.74, \text{ and}$$

$$\text{Moment: } \beta_{\text{elastic (sub-yield)}} = 2.99.$$

For shear--

$$\beta_{\text{yield}} \approx 2.1 * \beta_{\text{given}}, \text{ and}$$

$$\beta_{\text{collapse}} \approx 3.6 * \beta_{\text{given}}.$$

For moment--

$$\beta_{\text{yield}} \approx 2.5 * \beta_{\text{given}}, \text{ and}$$

$$\beta_{\text{collapse}} \approx 2.8 * \beta_{\text{given}}.$$

Additionally, central safety factor values are--

$$\text{for shear: } \theta_{\text{yield}}, \theta_{\text{collapse}} > 30 * \theta_{\text{given}};$$

$$\text{for moment: } \theta_{\text{yield}} \approx 3 * \theta_{\text{given}}, \text{ and}$$

$$\theta_{\text{collapse}} \approx 4.5 * \theta_{\text{given}}.$$

The reliability index level required for design is based more realistically on serviceability than ultimate capacity. A floor of a particular story in a structure may be heavily loaded, with a space saving bookcase for example. This example requires very small deflections, and a relatively high capacity. Calculating the reliability index for a limit state provides the engineer a physical meaning for the probability of failure for that mode.

The crux of the reliability index concept, making this more explicit than a factor of safety, is the ability to find the index value at any point. The reliability index relates directly to a unique probability of failure. Including a *full range* of limit states provides a means to quantify reserve strength. The constructed product is not always built precisely as the engineer specifies, and the occupant may use the facility for more than the design intended-- consequently, a great number of structures may experience some form of *overload*. In the definition of the ASD approach, the engineer would not have any reserve strength remaining, but the PBLSD approach clearly quantifies this reserve. Practically speaking, in a stable structure, the experienced engineer may not be alarmed by the former, but the PBLSD approach quantifies structural safety and shows any real cause for alarm or any reduced marginal capacity.

This method can be hard to apply though. In this report, V(R) was usually an assumed value. Not all necessary information may be obtained. The engineer must make a value judgement, or rely on advanced modeling techniques (der Kiureghian) to fill in blanks. This report provides a number of charts allowing the engineer to graphically check critical members for their reliability.

Additional Resources

Beer, F., and R. Johnston, Jr., *Mechanics of Materials*, McGraw-Hill Book Company, New York, 1981.

Der Kiureghian, A., and P-L Liu, *Structural Reliability under Incomplete Probability Information*, *Journal of Engineering Mechanics*, Vol 112, No 1, American Society of Civil Engineers, New York NY, January 1986.

Gerstle, K.H., *Basic Structural Design*, University of Colorado, Boulder CO.

Ugural, A.C., and Fenster, S.K., *Advanced Strength and Applied Elasticity: Second SI Edition*, PTR Prentice Hall, Englewood Cliffs NJ, 1987.

White, R.N., P. Gergely, and R.G. Sexsmith, *Structural Engineering: Volume 3, Behavior of Members and Systems*, John Wiley and Sons, New York NY, 1974.

Response to Dr. Spacone's Question

This paper summarizes the structural effects of semi-rigid connections. The primary focus centers on the guide articles--

Effect of Connections on Frames (Kurt Gerstle)

Seismic Moment Connections (Egor Popov)

Both discuss benefits for adding plastic behavior into the proverbial design equation. Dr. Gerstle's presentation is more general dealing with validating the extent for consideration of plastic connections. Dr. Popov's package illustrates observed plastic behavior of connections and highlights the large benefit of damping during an earthquake.

This summary will concentrate on four main points in the guide articles--

Range of effective connection flexibility;

Effects on frame behavior;

Damping effects; and

Affects on structural design.

The primary interest in these articles are the true benefits received by ductility and the hysteretical nature of steel.

Engineering designs are intended to be simple; business operates by the ideal--the quicker the design analysis, the more profit. However, simplicity cannot replace understanding, and certainly cannot withstand forensic scrutiny. As engineers understand more about the world around them, new ideas can be incorporated into an improved design. But simplicity should still be the rule--so the owner can understand what is purchased--but the engineer needs to know which approach is relevant.

Connections have usually been perceived as very rigid. In design, the engineer was required by code to make these very strong (McCormac, p. 229), primarily because of the allowable stress approach, but also because of the unknowns about behavior. Generally, designers wish to isolate local failures on the girders--the *strong columns/weak girders* approach. Allowing shear at the connection or buckling in the column would contribute far more toward general instability in the structure, thus engineers ensure plastic hinges occur in the girders (Popov, p. 164). Presuming 100% fixity of the girder to the column, such as in a finite element frame modeling program or as a concrete column/beam connection--illustrated below, may not be the

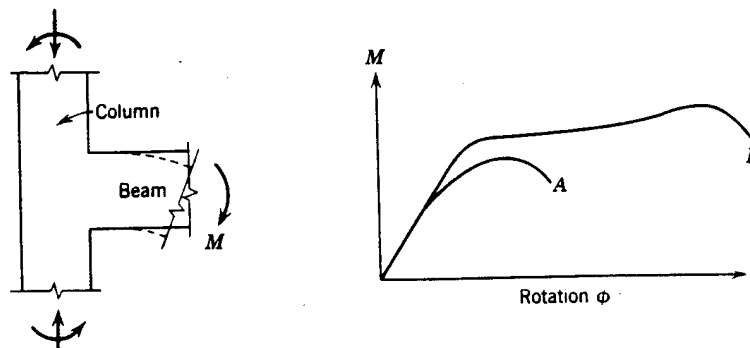

Beam-to-column connection example and moment-rotation characteristics (White, Figure 20.52, p. 139)

best assumption about the connection. The engineer must ensure compatibility in the connection with the girder and the beam. Dr. Gerstle established a range for determining the modeling technique, based on the non-dimensionalized stiffness (EI/kL) on the connection. Connection flexibility needs to be considered where--

$$0.05 < \left(\frac{EI}{kL} \right) < 2.0$$

His review of structural behavior found engineers could model girders and connections as either--

- fully rigid joints (lower bound--flexibility neglected),
- ideal pin end joints (upper bound), or
- flexibly connected joints

as shown below--

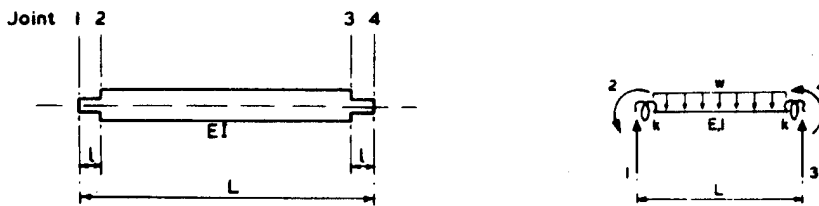

Flexible connections as part of girder--plan view and wire diagram (Gerstle, Figures 6 & 5b)

where--

$$k = \frac{E_{conn} I_{conn}}{l}$$

Further, his review of several *typical* structures found that--

$$\begin{aligned} \text{for bolted frames: } & 0.05 < \left(\frac{EI}{kL} \right) < 0.5, \text{ and} \\ \text{for welded frames: } & 0.02 < \left(\frac{EI}{kL} \right) < 0.1 \end{aligned}$$

so field bolted or lightly welded frames should be analyzed as flexibly connected ($EI/kL < 0.05$), reasonably heavy welds should be regarded as rigid ($EI/kL > 2.0$).

In tests Dr. Gerstle performed on three selected type of frame connections--bolted angles, fairly rigid flange plate connections, and welded joints--results indicated girder design moments are highly sensitive to connection flexibility, and columns were much less sensitive (Gerstle, p. 253). Those results also indicated current design methods, i.e., *rigid frame* and *simple framing* analysis, produce unconservative columns.

Important to connection flexibility is allowable side-sway, or the limit where exceeding may result in structural instability. This is illustrated below--

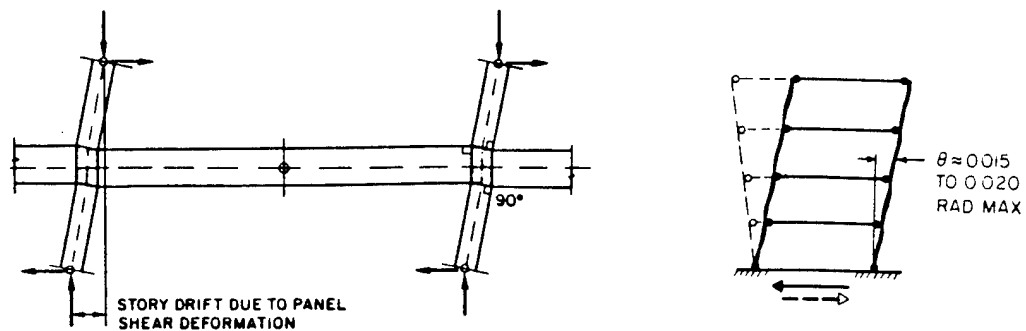

Admissible mechanism motion for determining/limiting rotation at joints (Popov, Figures 4 & 17)

Connection rotations account for a majority of total structural sway ($\frac{1}{3}$ to $\frac{2}{3}$) (Gerstle, p.255), more so than the elastic deflection of the columns.

Connection flexibility in steel frames affects both moment transfer and column effective length and ultimately, stability (ibid, p. 260). Non-linear behavior may rob the connection of rotational stability and strength.

But during an earthquake event, Dr. Popov relies on this non-linear behavior to rob the quake of some of its load effect. A structural frame experiences increasing dynamic reversing motions; the structure relies on deformation and initial plastification at the potential plastic hinge positions as well as the joints to absorb some of the earthquake's energy and damp the structure's responsive vibration (Popov, p. 167). Joints, such as those shown above, must be able to resist forces in either direction--whether tensile or compressive--and help preserve stability by reducing *story drift*. This joint panel design is shown as a free body diagram below, along with test results for cyclic load and deflections. Dr. Popov's results highlight the energy absorbing behavior--the area contained within the hysteretic loops provides an accurate measure of the damping. As long as the plastic behavior is relatively minor, i.e., the material does not approach rupture, the distortions can be accepted after the event without repairs. Especially since non-linear strain hardening behavior expands the elastic range.

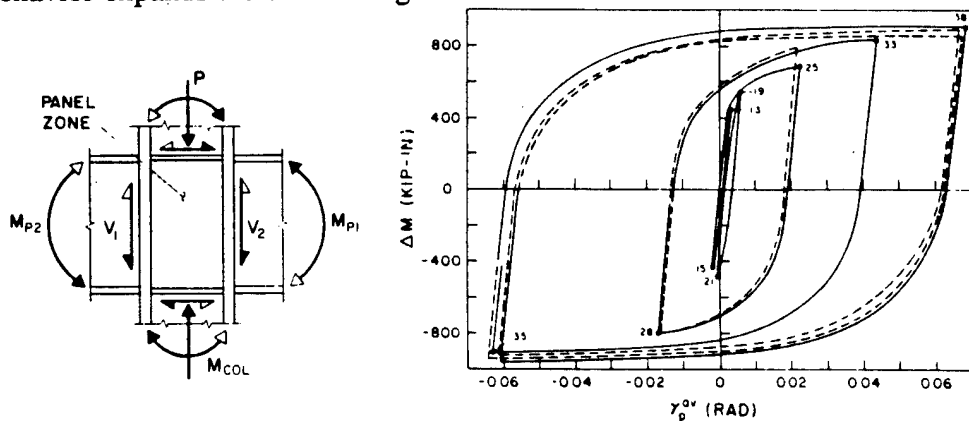

Joint panel mechanism as a free body with hysteresis load deflection test curve (Popov, Figures 3 & 18)

The test results mimic and validate the tri-linearized moment rotation model Dr. Gerstle presents.

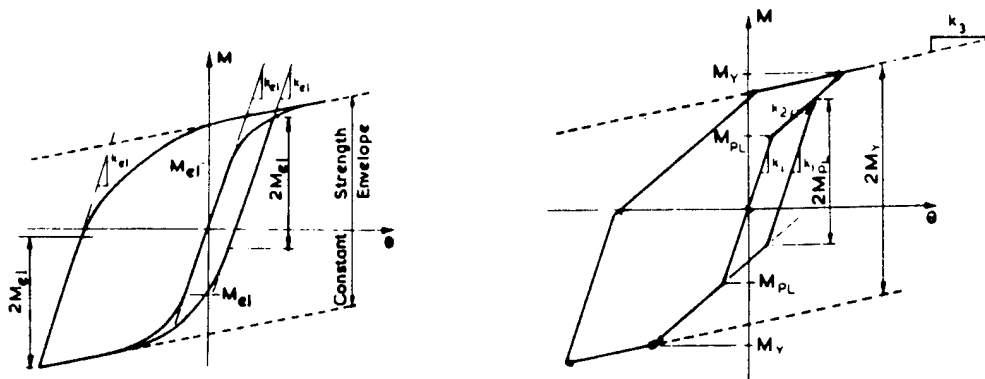

Load cyclic behavior and linearized moment-rotation response (Gerstle, Figures 3 & 11)

Observed behavior fits nicely, and this is quite sufficient as a deterministic model. This is due in large part to variability in construction fabrication--actual connection behavior will be subjected to some variance (Gerstle, p. 244).

For the above reasons, members and joints must be designed to be capable of deforming inelastically without failure or frame instability. A gradual transition is occurring among engineers from Allowable Stress Design (ASD) to Load and Resistance Factor Design (LRFD) (Popov, p. 164). LRFD encourages reliance on inelastic behavior and ductile moment capacity, intending to mitigate potential earthquake forces with little damage.

Dr. Gerstle's package announced a computer design program developed iteratively to optimize a frame member to produce a compatible girder/column connection to isolate a potential plastic hinge only in the girder. The algorithm for accomplishing this is (Gerstle, p. 264)--

- sizing members by deterministic rigid frame analysis;
- modifying sizes (for stiffness) to resist full internal forces;
- resizing members by converging (iterate) on linearly elastic/plastic behavior.

It is important for engineers to have the capability to analyze flexibility in frame design, suited for easy office use. These analysis considerations require only minor modifications to the commonly used (finite element) procedures (Gerstle, p. 247). These concepts are fundamental to the structural engineer, and should be instituted in practice after some study.

Resources

Chajes, A., *Principles of Structural Stability Theory*, Waveland Press Inc, Prospect Heights, IL, 1974.

(Guide Article) Gerstle, K.H., *Effect of Connections on Frames*, Journal of Construction and Steel Research (Volume 10), Elsevier Science Publishers Ltd, Great Britain, 1988.

McCormac, J.C., *Structural Steel Design, Third Edition*, Harper & Row Publishers, New York NY, 1981.

Manual of Steel Construction: Load & Resistance Factor Design, Second Edition, Volume 2 (Connections), American Institute of Steel Construction, New York NY, 1994.

(Guide Article) Popov, E.P., *Seismic Moment Connections for MRFs (moment-resisting frame)*, Journal of Construction and Steel Research (Volume 10), Elsevier Science Publishers Ltd, Great Britain, 1988.

White, R.N., P. Gergely, and R.G. Sexsmith, *Structural Engineering: Volume 3, Behavior of Members and Systems*, John Wiley and Sons, New York NY, 1974.