

ARMY RESEARCH LABORATORY



A Large-Dynamic-Range Fiberoptic Signal Link for Low-Frequency Signals

by James C. Blackburn and Edward R. Sebol

ARL-MR-207

June 1995

The findings in this report are not to be construed as an official Department of the Army position unless so designated by other authorized documents.

Citation of manufacturer's or trade names does not constitute an official endorsement or approval of the use thereof.

Destroy this report when it is no longer needed. Do not return it to the originator.

REPORT DOCUMENTATION PAGE

Form Approved
OMB No. 0704-0188

Public reporting burden for this collection of information is estimated to average 1 hour per response, including the time for reviewing instructions, searching existing data sources, gathering and maintaining the data needed, and completing and reviewing the collection of information. Send comments regarding this burden estimate or any other aspect of this collection of information, including suggestions for reducing this burden, to Washington Headquarters Services, Directorate for Information Operations and Reports, 1215 Jefferson Davis Highway, Suite 1204, Arlington, VA 22202-4302, and to the Office of Management and Budget, Paperwork Reduction Project (0704-0188), Washington, DC 20503.

1. AGENCY USE ONLY (Leave blank)		2. REPORT DATE June 1995	3. REPORT TYPE AND DATES COVERED Final, from April to August 1993	
4. TITLE AND SUBTITLE A Large-Dynamic-Range Fiberoptic Signal Link for Low-Frequency Signals			5. FUNDING NUMBERS PE: 62120	
6. AUTHOR(S) James C. Blackburn and Edward R. Sebol				
7. PERFORMING ORGANIZATION NAME(S) AND ADDRESS(ES) U.S. Army Research Laboratory Attn: AMSRL-WT-NG 2800 Powder Mill Road Adelphi, MD 20783-1197			8. PERFORMING ORGANIZATION REPORT NUMBER ARL-MR-207	
9. SPONSORING/MONITORING AGENCY NAME(S) AND ADDRESS(ES) U.S. Army Research Laboratory Attn AMSRL-WT-NA 2800 Powder Mill Road Adelphi, MD 20783-1197			10. SPONSORING/MONITORING AGENCY REPORT NUMBER	
11. SUPPLEMENTARY NOTES AMS code: 612120.1400011 ARL PR: 3FE425				
12a. DISTRIBUTION/AVAILABILITY STATEMENT Approved for public release; distribution unlimited.			12b. DISTRIBUTION CODE	
13. ABSTRACT (Maximum 200 words) <p>The fiberoptic signal link was intended specifically for transmission of instrumentation signals from a test object immersed in a strong rf field, where electrically conducting connections were unsuitable. The link has a dc-to-10-kHz bandwidth and a 70-dB dynamic range with 1 percent linearity. The design is practical, using low-cost electronic and electro-optic components.</p>				
14. SUBJECT TERMS Fiberoptics, fiberoptic signal link			15. NUMBER OF PAGES 14	
			16. PRICE CODE	
17. SECURITY CLASSIFICATION OF REPORT Unclassified	18. SECURITY CLASSIFICATION OF THIS PAGE Unclassified	19. SECURITY CLASSIFICATION OF ABSTRACT Unclassified	20. LIMITATION OF ABSTRACT UL	

Contents

1. Introduction	5
2. Circuitry—Transmitter	6
2.1 <i>Input Amplifier</i>	8
2.2 <i>Oscillator (Voltage-to-Frequency Converter)</i>	8
2.3 <i>Output Driver</i>	9
2.4 <i>Power Supply</i>	9
3. Circuitry—Receiver	10
4. Test Results	12
5. Mechanical Assembly	12
6. Conclusion	12
Distribution	13

Figures

1. External view of transmitter and receiver	5
2. Internal view of transmitter	6
3. Close view of transmitter circuit board	6
4. Functional and schematic diagrams of optical transmitter	7
5. Functional and schematic diagrams of optical receiver	11

Table

1. Signal input to transmitter and signal output from receiver for two transmitter temperatures	12
---	----

1. Introduction

The described fiberoptic telemetry link, shown in figures 1 to 3, is a practical instrument for transmission of low-frequency, low-level instrumentation signals in the high electric fields associated with high-power microwave (HPM) testing. The purpose of the link is to provide a means of accurately monitoring low-frequency electrical signals within a device being irradiated by high-level microwave signals. The signal is carried on an optical fiber, which, being a non-conductor, does not provide a conduit for signal leakage into the system under test.

The self-contained (battery-powered) transmitter accepts the electrical signal and converts it into an FM pulse repetition frequency (prf) modulated optical signal, which is conveyed by optical fiber to a receiver, where it is converted back into an electrical signal. The input-to-output gain is $10\times$, $1\times$, or $0.1\times$, depending on the selected transmitter gain, with a full-scale receiver output of ± 5.0 V. The dynamic range, the range between the noise level and the onset of nonlinearity due to overload, is approximately 70 dB on any one range. A 10-kHz input of $100\ \mu\text{V}$ amplitude, down 5000-fold from a full-scale 0.5-V input, is readily observed on an oscilloscope connected to the receiver output. The 3-dB bandwidth is dc to 10 kHz. The rechargeable batteries in the transmitter are adequate for approximately 8 hr of use per charge. The interconnecting two-fiber fiberoptic cable is highly flexible and about 0.1×0.2 in. It contains two fibers, one for controlling transmitter power (on/off) and the other for carrying the FM-modulated optical signal. Transmission up to more than 1 km is possible even with this low-cost (\$0.80 per meter) cable. The transmitter is presently configured such that the package is $4\frac{3}{4} \times 1\frac{1}{2} \times \frac{3}{4}$ in.—a large reduction in size is possible.

Figure 1. External view of transmitter and receiver.

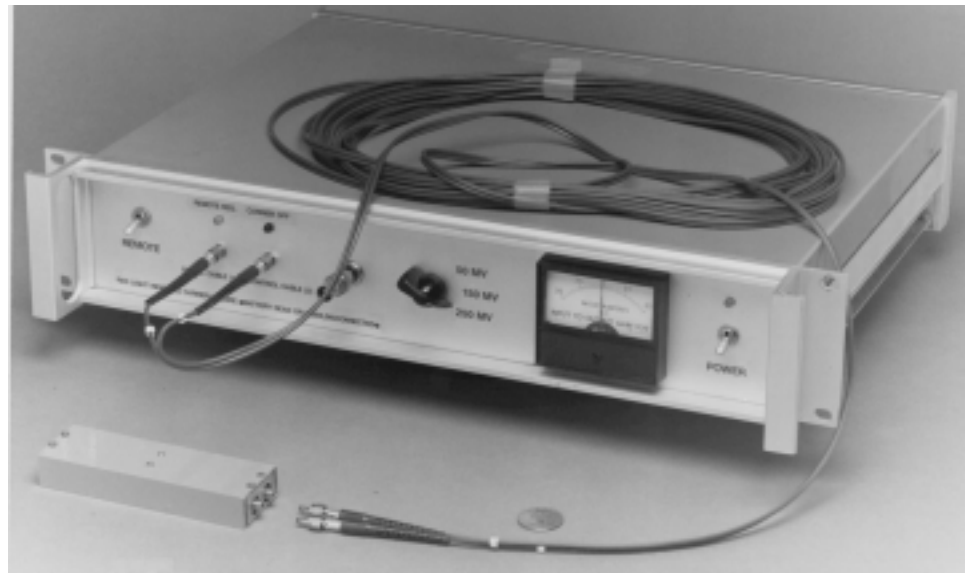

Figure 2. Internal view of transmitter.

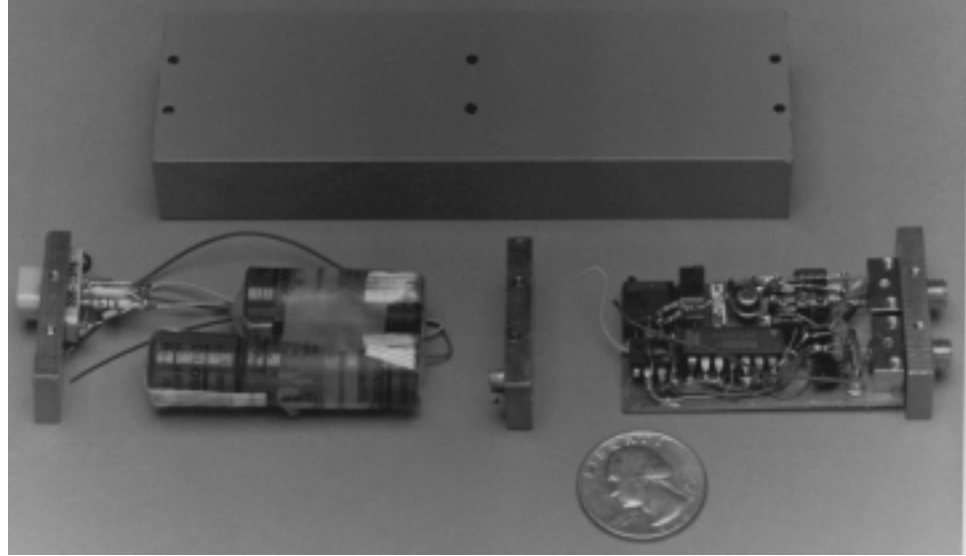
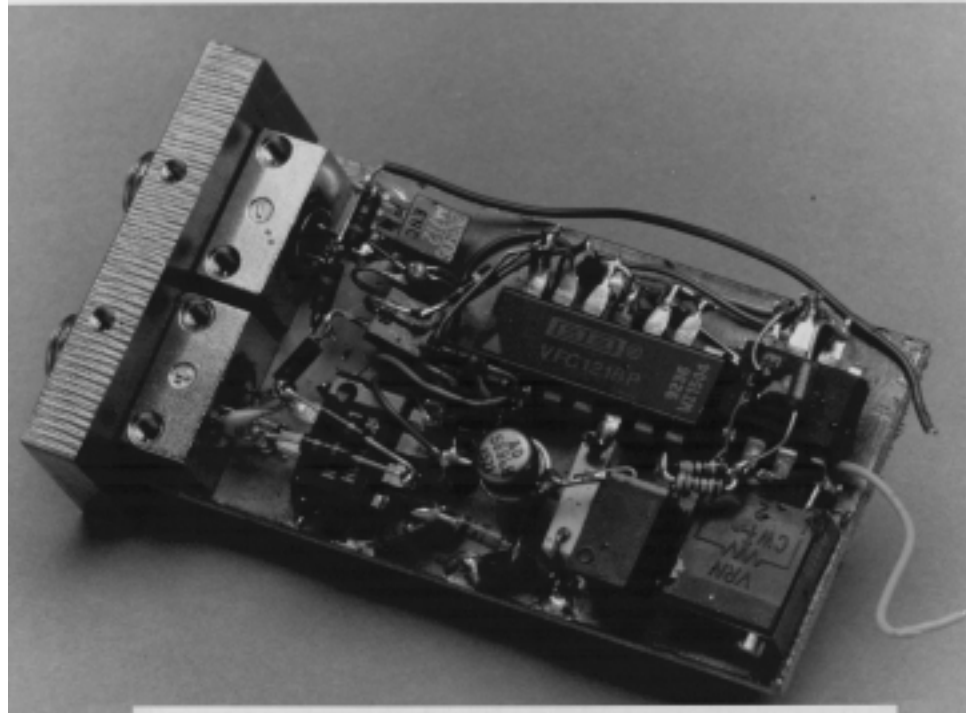

Figure 3. Close view of transmitter circuit board. Fiberoptic connectors at left.



2. Circuitry—Transmitter

Figure 4 shows the circuit diagram of the transmitter. The transmitter consists of an attenuator and input amplifier followed by a linear variable frequency oscillator, a one-shot pulse generator, and the light-emitting diode (LED) with its driver, Q_3 . Auxiliary circuits include the optically controlled power switch, Q_6 - Q_7 , and the negative supply charge pump and battery voltage comparator, Q_8 .

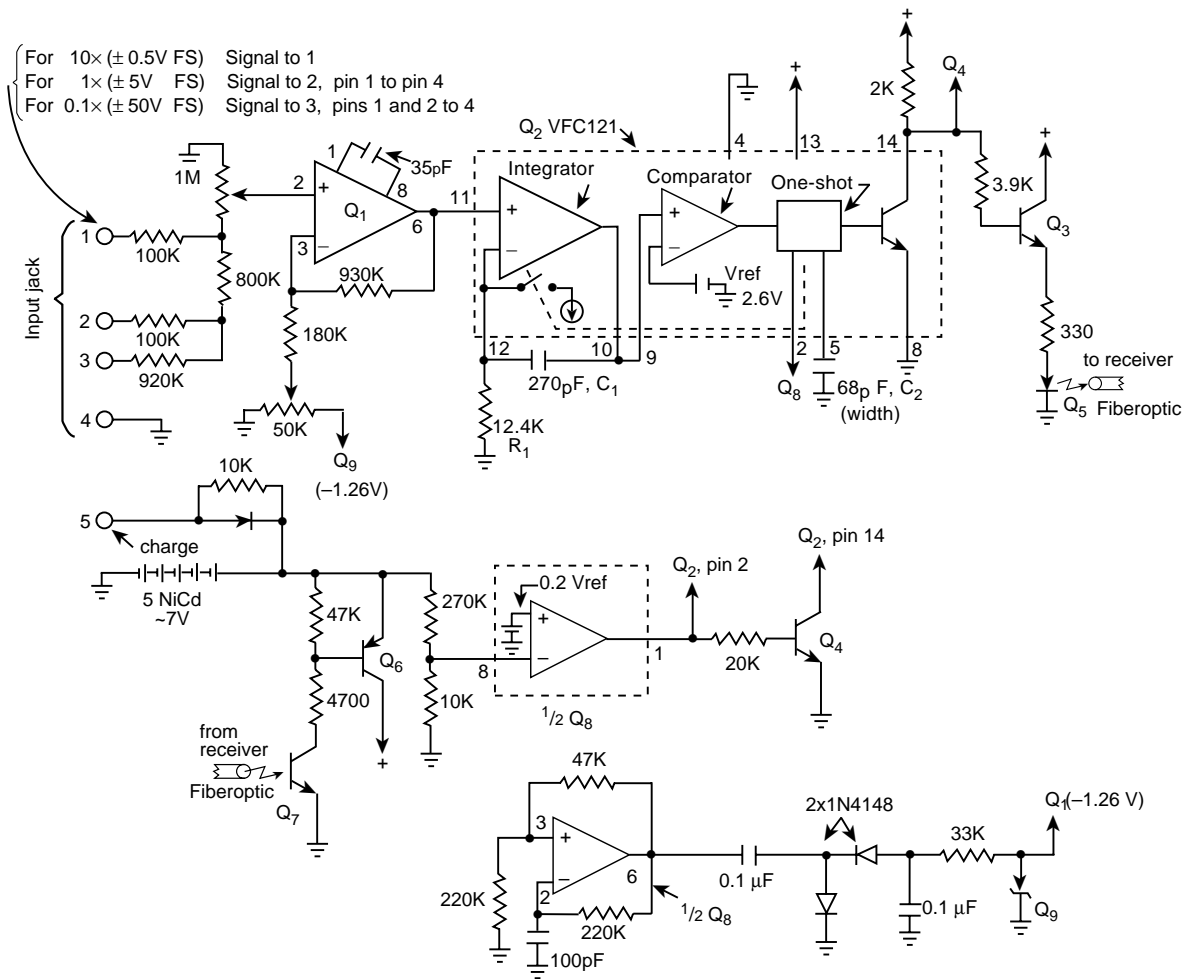
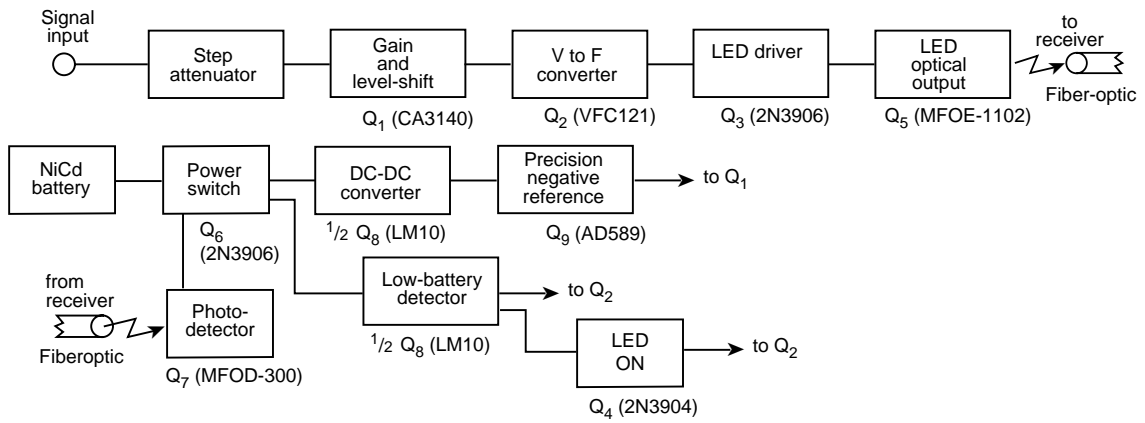

Figure 4. Functional and schematic diagrams of optical transmitter.

2.1 Input Amplifier

The CA3140 (Q_1) was used as an input amplifier because of its ability to handle input voltages below the negative rail (here, ground), because of its high input impedance, and because its output range extends to near ground (0.2 V), making good use of the dynamic range of the next stage, Q_2 . Its slew rate is more than adequate for this application, and the input stage, including the uncompensated resistive attenuator, has a bandwidth of more than 300 kHz. The negative bias applied to the inverting terminal shifts the level of the input so that the signal output from Q_1 is always positive, as required by the input of the next stage, Q_2 , the variable-frequency generator. Initially we attempted to provide the necessary offset by using the “offset null” connections of Q_1 , avoiding the need for a negative supply; this seriously degraded the temperature stability and, hence, was unsatisfactory. Summing a reference positive current with the signal at the negative input to the amplifier was also considered, but it would have rendered the gain sensitive to the signal-input impedance, which is undesirable. After passing through the attenuator, the signal input to Q_1 is, at a maximum, in the range of ± 0.25 V, keeping well away from the -0.5 -V common mode limit of Q_1 .

2.2 Oscillator (Voltage-to-Frequency Converter)

The output of Q_1 is applied to Q_2 , which generates pulses whose repetition rate is controlled by the input signal that it receives from Q_1 and whose width (250 ns) is constant, controlled by the one-shot period. Initially the current applied to the (+) input (pin 11) of Q_2 is integrated, causing its output to ramp upward, charging C_1 at a rate proportional to $1/R_1$, $1/C_1$, and the input voltage. When the output reaches the comparator trip-level, the comparator triggers the one-shot. The one-shot both furnishes an output (via pin 14) and transfers the input of the integrator (op amp) to an internal negative constant current source; this causes the ramp to decrease to its original value. When the one-shot times out, the input of the op amp is again connected to the external input, and the sequence repeats.

The width of the one-shot pulse (and the down-ramp) is constant, controlled by a zero temperature-coefficient capacitor (C_2), and the internal current source of the one-shot pulse is stable; therefore, the amount of charge placed on C_1 during the down-ramp is constant. The interval of the up-ramp is determined by the time necessary to replace this charge through R_1 , a precision resistor, in series with the input voltage at pin 11 of Q_2 (pin 12 is, of course, at essentially the same voltage as pin 11). The interval of the up-ramp is, therefore, proportionally to the input voltage; C_1 is not critical. In a similar fashion the trip-point of the comparator is not critical; it needs only to remain constant between successive up-down cycles.

The value of R_1 is chosen so that the upper frequency, corresponding to a maximum positive input, is 1200 kHz and the lower frequency is 200 kHz (for minimum input). These limits are dictated by the need to avoid an increased frequency drift of the oscillator at higher frequencies and by the

need to keep the carrier frequency substantially above the highest input signal frequency, even when the input is at a minimum value.

2.3 Output Driver

The LED driver, Q_4 , is straightforward. It supplies 18 mA to the LED, which generates the optical signal. Its polarity sense is such that it drives the LED “on” during the width of the one-shot pulse. Q_3 has a function related to the power circuits discussed in the next section.

2.4 Power Supply

The input amplifier and the voltage-to-frequency converter (VFC), Q_2 , are specified for operation at supply voltages of 5 V or greater; for this reason the power source selected is five NiCd cells. These cells supply 6.7 V when fully charged and are nearly depleted when their voltage has dropped to 5 V.

Photo-transistor Q_7 and transistor Q_6 form the power switch, which is “on” whenever the photo transistor is illuminated by the control fiber, which is in turn illuminated by an LED at the receiving end of the link when the transmitter is to operate. Since room light is entirely adequate to turn the system on, it is necessary to cover the photo transistor when the fiber is detached from it.

One half of Q_8 is an amplifier with a voltage reference established at its (+) input: this is used to provide low battery protection. When the battery voltage falls below 5.3 V, the output of the op amp goes high. This simultaneously disables the oscillator’s drive to the LED and enables Q_4 , which pulls the LED on. The energizing of the LED serves two functions: (1) it assures that the battery voltage continues to fall, avoiding an on-off oscillation of the power, and (2) the steady illumination of the fiber can be monitored at the receiver end of the fiber to show that the optical fiber is intact and that the loss of carrier signal (a result of the shutdown of the oscillator) is due to a low battery and not to a broken fiber. The battery has enough energy to light the LED for several minutes after carrier shutdown has occurred.

The other half of Q_8 forms a charge pump, consisting of an oscillator and an ac-coupled negative peak detector. It generates the system’s negative supply voltage with a battery power consumption of only a few hundred microamps. Its relatively slow rise and fall times avoid the potential for noise-coupling into neighboring circuits, such as may occur with the commonly used ringing-inductor voltage changer.

The current requirement for the entire transmitter circuit depends on the signal input voltage since this controls the duty cycle of the LED, a major power sink in the device; the total current varies between about 10 and 15 mA. This provides, as a worst case, an 8-hr continuous running time, as was desired in the design application, with 1/3 AA-size NiCd cells rated at 110 mA/hr.

3. Circuitry—Receiver

The variable repetition-rate photo pulse sent from the transmitter via the signal fiber is detected (fig. 5) by an integrated detector-amplifier, which delivers a negative-going output pulse varying between approximately +3 and +2 V. This triggers comparator Q_2 , which drives a 74LS121 one-shot. The duration of the 121's output pulse is wider than that of the optical pulse in order to avoid possible multiple triggers from the comparator in the event of a weak optical signal, resulting in a noisy leading edge at the comparator's input. The second half of the 121 one-shot provides a convenient way to monitor the presence of an optical carrier signal; it is triggered most of the time, keeping its Q output low and the red LED off, as long as the carrier is being received. The $\overline{\text{CLR}}$ input extinguishes the LED when the absence of a signal is a (desired) result of turning the transmitter off, via S1.

A second VFC, Q_4 , a VFC 320, is triggered by the one-shot. It is very similar to the VFC 121 used in the transmitter, with somewhat better performance; but it is also more power hungry, making it unsuitable for the transmitter. In this receiving application, its charge pump, driven by the on-chip one-shot, is used to supply an average current, proportional to the prf, to an integrator, C_1 . The unusual 5-k Ω resistor at the output of the integrator is to aid it in sourcing current in this application, where output is always negative. The output of the integrator is fed through a four-pole low-pass Sallen-Key filter (Q_5) to remove the ripple, which is considerable when the received frequency is near its minimum (200 kHz). The filter is effective: the ripple is about 70 dB down after passing through the filter. The degree of feedback in the second filter stage, which controls its damping factor and response, was arrived at experimentally; the best square wave response was obtained with the values given. The output of the filter is passed through an output driver stage, which also allows for gain and offset adjustment, so that with a 700-kHz prf input the output is zero, with a 200-kHz prf input the output is -5.00 V, and with a 1200-kHz prf input the output is +5.00 V.

The final circuits of the receiver are the gain setting and offsetting stage and the meter driver. Since the receiver was intended to feed directly into a high-impedance recorder through a modest length of cable, the 100- Ω output impedance was satisfactory.

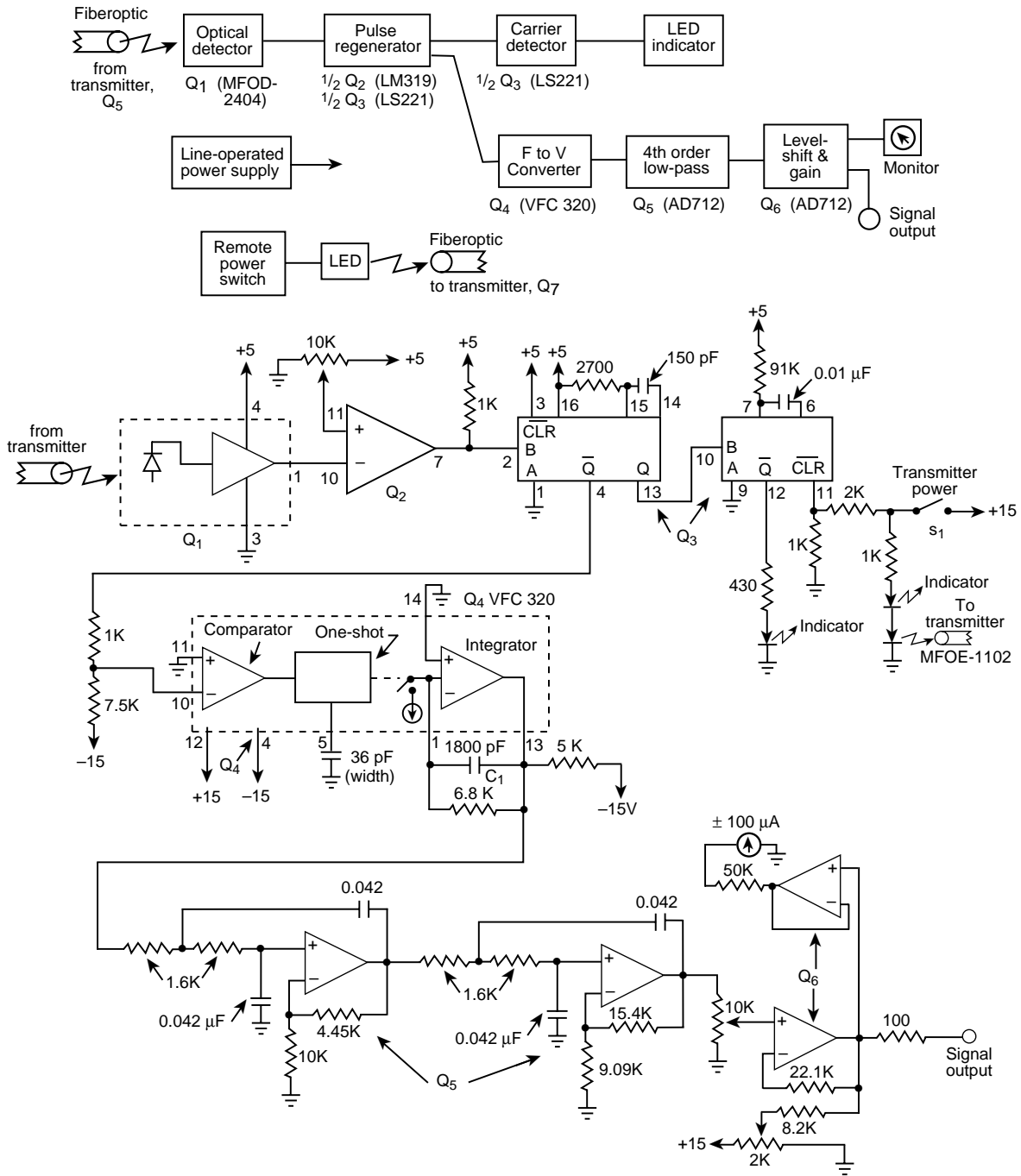

Figure 5. Functional and schematic diagrams of optical receiver.

4. Test Results

Linearity is exhibited in table 1; it is seen to be within 1 percent over the entire operating range. The response to heating the transmitter from room temperature to 60°C (140°F) was a -40-mV drift, less than 1 percent of full scale, with negligible change in linearity. This drift is primarily a result of the temperature response of the CA3140, which forms the input amplifier.

Table 1. Signal input to transmitter and signal output from receiver for two transmitter temperatures.

Signal input (mV)	Signal output (V)	
	@25°C	@6°C
550.	5.50	—
500.	5.01	4.97
100.	1.01	0.961
50.	0.049	—
0.00	0.00	-0.040
-50.	-0.052	—
-100.	-1.00	-1.04
-500.	-5.02	-5.05
-550.	-5.55	—

5. Mechanical Assembly

In the original breadboard of the transmitter (fig. 2 and 3), effective electrostatic shielding was essential to avoid potential interference from the microwave field illuminating the device under test. Such shielding is provided by the close-fitting enclosure, made from a WR-137 waveguide, and the decoupling is provided by feed-through capacitors in the septum between the battery and attenuator compartment and the active electronics. Not shown are a number of ferrite beads, which are placed over the battery and signal input leads that pass through the feed-through capacitors. The filter produced by the series inductance of these ferrite-loaded leads, shunted by the feed-through capacitors, avoids coupling of rf into the active circuits.

6. Conclusion

The fiberoptic signal link described has proven reliable in field use and inexpensive to construct. It provides accurate and noise-free transmission of low-frequency signals in the presence of high levels of electromagnetic interference such as HPM testing and nuclear radiation simulators.

Distribution

Admnstr
Defns Techl Info Ctr
Attn DTIC-DDA (2 copies)
Cameron Sta Bldg 5
Alexandria VA 22304-6145

Army Matl Comnd
Attn AMCRD-AR J Aveta
5001 Eisenhower Ave
Alexandria VA 22333-0001

Belvoir Rsrch Dev & Engrg Ctr
Attn STRBE-NA S Schaedel
FT Belvoir VA 22060-5606

US Army CECOM
Attn AMSEL-RD-NV-ADS-SP M Kovach
FT Monmouth NJ 07703-5206

US Army CECOM Intlgncl/Elect Warfare
Drcrt
Attn AMSEL-RD-IEW-SPO D Helm
Vint Hill Farm Sta
Warrenton VA 22186-5100

US Army Mis Comnd
Attn AMSMI-RD-WS-UB D Holder
Redstone Arsenal AL 35898-8000

Nvl Rsrch Lab
Attn Code 4650 T Wieting
4555 Overlook Avenue SW
Washington DC 20375-5000

Sp & Nav Warfare Sys Comnd
Attn SPAWAR 332 J Albertine
2451 Crystal Park
Arlington VA 22245-5200

US Air Force Phillips Lab
Attn PL/WSH H Dogliani
Attn PL/WSH M Harrison
Attn PL/WSH S Mason
Attn PL/WSH W Snyder
3550 Aberdeen Ave SE
Kirtland AFB NM 87117-6008

US Army Rsrch Lab
Attn AMSRL-OP-SD-TA Mail & Records
Mgmt
Attn AMSRL-OP-SD-TL Tech Library
(3 copies)
Attn AMSRL-OP-SD-TP Tech Pub
Attn AMSRL-SS-SG J McCorkle
Attn AMSRL-WT-NA R A Kehs
Attn AMSRL-WT-NF E Scannell
Attn AMSRL-WT-NF L Jasper
Attn AMSRL-WT-NF R Kaul
Attn AMSRL-WT-NF T Bock
Attn AMSRL-WT-NG J Blackburn
(10 copies)
Attn AMSRL-WT-NH G Huttlin
Attn AMSRL-WT-NH J Corrigan
Adelphi, MD 20783-1197

DEPARTMENT OF THE ARMY
U.S. Army Research Laboratory
2800 Powder Mill Road
Adelphi, MD 20783-1197

An Equal Opportunity Employer