

REPORT DOCUMENTATION PAGE

Form Approved
OMB No. 0704-0188

Public reporting burden for this collection of information is estimated to average 1 hour per response, including the time for reviewing instructions, searching existing data sources, gathering and maintaining the data needed, and completing and reviewing the collection of information. Send comments regarding this burden estimate or any other aspect of this collection of information, including suggestions for reducing this burden, to Washington Headquarters Services, Directorate for Information Operations and Reports, 1215 Jefferson Davis Highway, Suite 1204, Arlington, VA 22202-4302, and to the Office of Management and Budget, Paperwork Reduction Project (0704-0188), Washington, DC 20503.

1. AGENCY USE ONLY (Leave blank)	2. REPORT DATE 7-21-95	3. REPORT TYPE AND DATES COVERED FINAL 5/1/91 - 12/31/94
----------------------------------	---------------------------	---

4. TITLE AND SUBTITLE New Approaches in Optical Data Storage: A Feasibility Study	5. FUNDING NUMBERS N00014-93-1-0450
---	--

6. AUTHOR(S) N. Peyghambarian and S. W. Koch

7. PERFORMING ORGANIZATION NAME(S) AND ADDRESS(ES) Optical Sciences Center University of Arizona Tucson, AZ 85721	8. PERFORMING ORGANIZATION REPORT NUMBER NTIS CRA&I <input checked="" type="checkbox"/> DTIC TAB <input type="checkbox"/> Unannounced <input type="checkbox"/> Justification _____
--	--

9. SPONSORING / MONITORING AGENCY NAME(S) AND ADDRESS(ES) Office of Naval Research 800 North Quincy Street Arlington, VA 22217-5000	10. SPONSORING / MONITORING AGENCY REPORT NUMBER Distribution / Availability Codes Dist Avail and/or Special
--	---

11. SUPPLEMENTARY NOTES	A-1
-------------------------	-----

12a. DISTRIBUTION / AVAILABILITY STATEMENT Available to public	19950724 176
---	--------------

13. ABSTRACT (Maximum 200 words) Extensive progress was made in the following areas: <ul style="list-style-type: none"> - Demonstration of room-temperature spectral hole burning in CdS quantum dot samples. - Fabrication of the first quantum dot slab and channel waveguides and measurements of femtosecond pulse propagation in these waveguides. - Fabrication of the first circular grating in a quantum dot waveguide.
--

DTIC QUALITY INSPECTED 6

14. SUBJECT TERMS spectral hole burning; quantum dots; circular grating	15. NUMBER OF PAGES 8
--	--------------------------

16. PRICE CODE

17. SECURITY CLASSIFICATION OF REPORT UNCLASSIFIED	18. SECURITY CLASSIFICATION OF THIS PAGE UNCLASSIFIED	19. SECURITY CLASSIFICATION OF ABSTRACT UNCLASSIFIED	20. LIMITATION OF ABSTRACT UL
---	--	---	----------------------------------

FINAL REPORT FOR GRANT #N00014-93-1-0450

We had extensive progress during the last year, as summarized below.

- (1) Demonstration of room-temperature spectral hole burning in CdS quantum dot samples.
- (2) Fabrication of the first quantum dot slab and channel waveguides and measurements of femtosecond pulse propagation in these waveguides.
- (3) Fabrication of the first circular grating in a quantum dot waveguide.

The following describes these achievements in more detail.

We succeeded in demonstrating spectral hole burning at room temperature in CdS quantum dot samples prepared by the sol-gel and glass-fusion techniques. Figure 1(a) shows the linear absorption spectrum of a CdS dot sample prepared by the conventional glass-fusion method.^{1,2} Figure 1(b) shows changes in absorption of the sample when pumped at 419 nm and 447 nm at room temperature. Transient spectral hole burning due to state filling is observed in the sample as absorption bleaching whose peak follows the frequency of the exciting laser. With extended laser irradiation of the sample for 2 hours at the same pumping wavelengths, persistent spectral changes are observed that are not very sensitive to the laser excitation frequency, as shown in Fig. 1(c). Note that the $-\Delta\alpha L$ signal in Fig. 1(b) has a positive peak on the low-energy side and a negative peak on the high-energy side, in contrast to Fig. 1(c) where a negative peak appears on the low-energy side.

We extended our previous model calculations^{3,4} to this case in order to understand the measured results. Figure 2 shows the results of our calculations, which include quantum-confinement effects, electron-hole Coulomb interaction, and surface polarization effects. The calculated linear absorption spectrum of Fig. 2(a) resembles that of Fig. 1(a) from experiment. The measured transient absorption changes of Fig. 1(b) are reproduced by theory in Fig. 2(b), which results from the bleaching of the lowest quantum-confined transition [positive low energy peak in Fig. 2(b)] and induced absorption due to the two-pair transitions on the high-energy side [the negative peak in Fig. 2(b)]. This indicates the transient absorption changes can be explained as saturation of a selected size of semiconductor quantum dots. Figure 2(c) represents quantum-confined Stark effect calculations on our quantum dot samples. The similarity between the calculated Fig. 2(c) and the measured Fig. 1(c) indicates that the persistent absorption changes may have their origin in the quantum-confined Stark effect in quantum dots. Therefore, the theory-experiment comparison suggests that under strong laser irradiation, photo-excited carriers are ejected out of the volume of the quantum dots into surface states or into the surrounding glass matrix, as schematically shown in Fig. 3. The presence of carriers in trap sites at the glass-

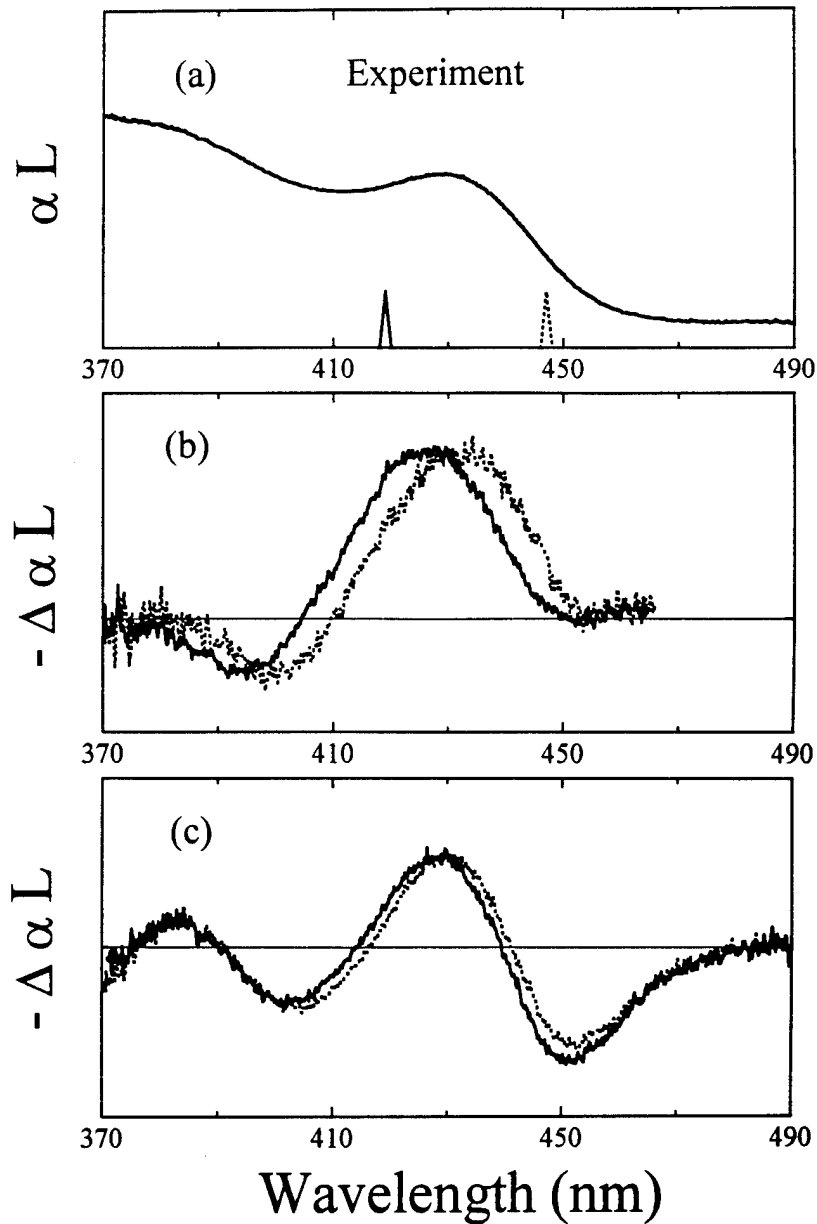

Figure 1. (a) The linear absorption spectrum of a CdS quantum dot sample at room temperature. The positions of the pumps used in (b) and (c) are shown by the small peaks at wavelengths of 419 nm and 447 nm. Solid (dashed) spectra in (b) and (c) are associated with pumping at 419 nm (447 nm). (b) The change in the absorption ($-\Delta\alpha L$) obtained as a result of this pumping. The absorption bleaches and spectral holes are generated, which shift as the pump wavelength is changed. This figure clearly demonstrates transient spectral hole burning at room temperature in a quantum dot sample. (c) The persistent absorption changes obtained when the sample was photodarkened as a result of extended pump exposure, showing that the persistent absorption changes are not very sensitive to the laser excitation frequency.

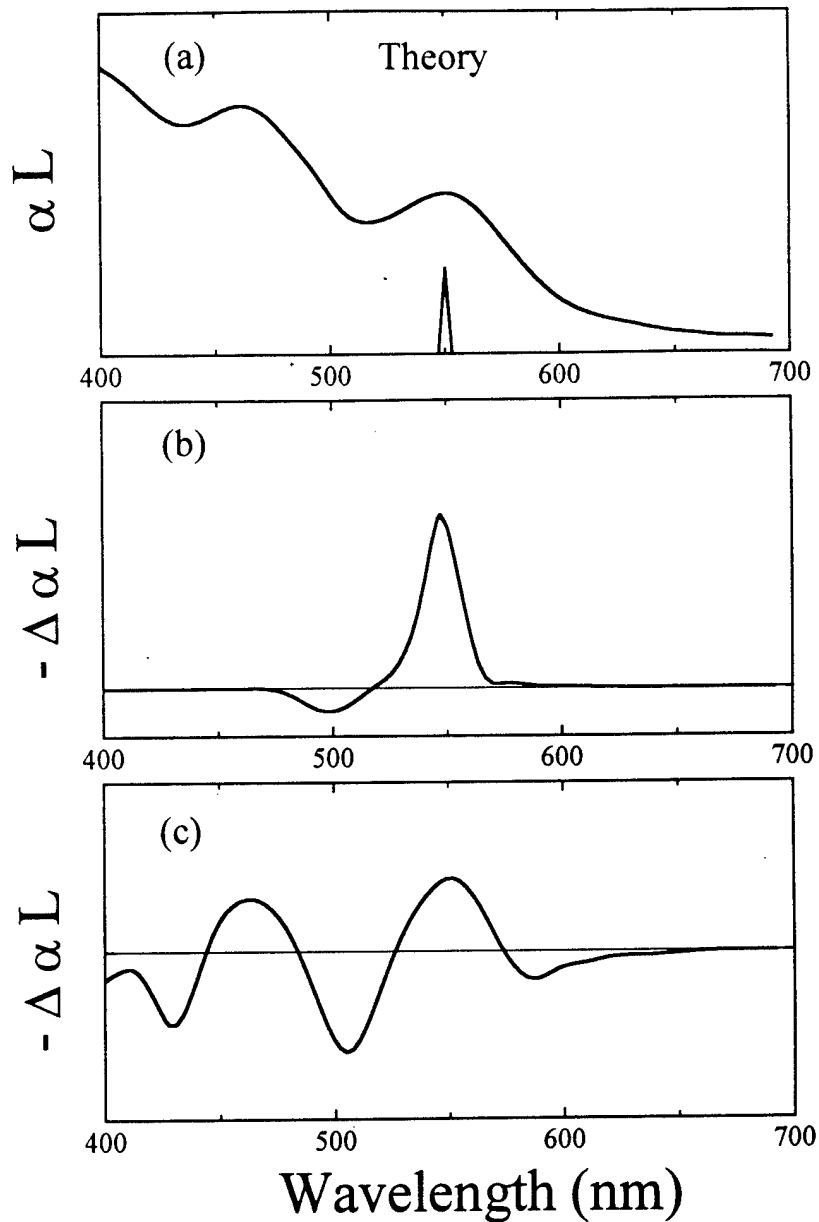

Figure 2. (a) Calculated linear absorption and (b) the absorption change ($-\Delta\alpha L$) obtained for a quantum dot sample for pump wavelength of 550 nm inside the first quantum-confined transition. The position of the pump wavelength is shown by the small peak. This curve is similar to the experimental results shown in Fig. 1(b). (c) Calculated quantum-confined Stark effect showing the change in absorption ($-\Delta\alpha L$) as a result of the application of a dc electric field. The absorption changes calculated here are similar to the experimental results shown in Fig. 1(c).

semiconductor interface results in changes of the optical properties of the sample, which are collectively known as photodarkening. This mechanism is supported by calculations showing that for quantum dots with small radii, the induced surface polarization leads to electron-hole localization around the semiconductor-glass interface.⁵

In addition to these results, we have also succeeded in fabricating the first cadmium sulfide quantum dot sol-gel glass channel waveguide using the potassium ion-exchange technique. The waveguides were optically characterized and we performed femtosecond pulse propagation measurements in these waveguides to search for dispersive solitons in semiconductors. Our cross-correlation measurements show significant pulse shaping after femtosecond laser pulses are propagated through the waveguide.

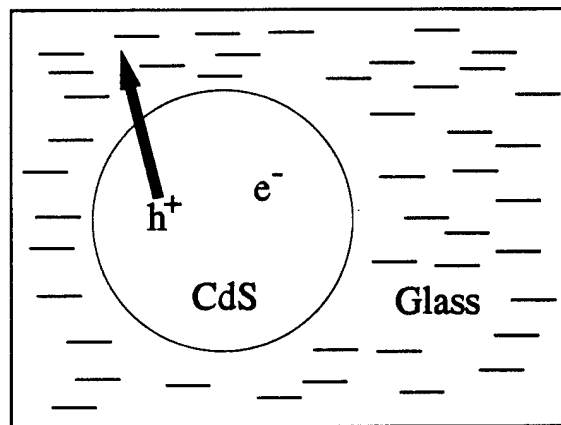

Figure 3. Schematic representation of the mechanism of the photodarkening effect indicating the tunneling of the photogenerated charged carriers out the quantum dot into traps in the glass surrounding the dots, which changes the overall static Coulomb field around the quantum dot.

The measured transmission spectrum of the CdS quantum dot waveguide is shown in Fig. 4. The transmission drop for short wavelength is due to the long tail absorption of the CdS quantum dots. The noise comes primarily from the spectral response of the silicon detector used. The sudden drop in transmission near 700 nm corresponds to the cut-off frequency of the quantum dot waveguide, which is a function of the index of refraction difference between the host glass and the ion-exchanged waveguide. The inset of Fig. 4 shows the absorption spectrum of the quantum dot sample itself. The lowest quantum-confined transition appears as a shoulder in the spectrum.

Femtosecond pulse propagation through the CdS quantum dot waveguide was studied using a continuously tunable amplified colliding pulse mode-locked (CPM) dye laser system (Fig. 5). The 60-fs pulses centered at 620 nm from the first amplifier stage were divided into two beams. One beam served

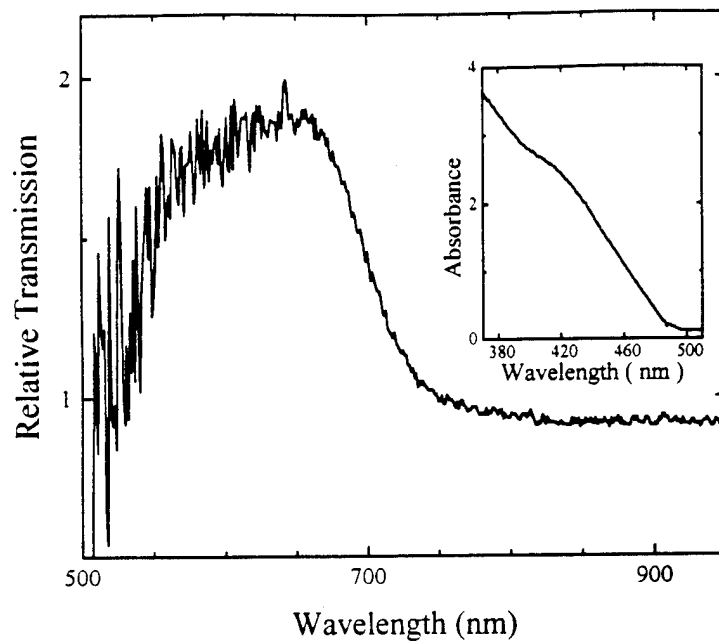

Figure 4. Measured spectral transmission of the CdS quantum dot waveguide. The inset is the absorption spectrum of the quantum dot sample.

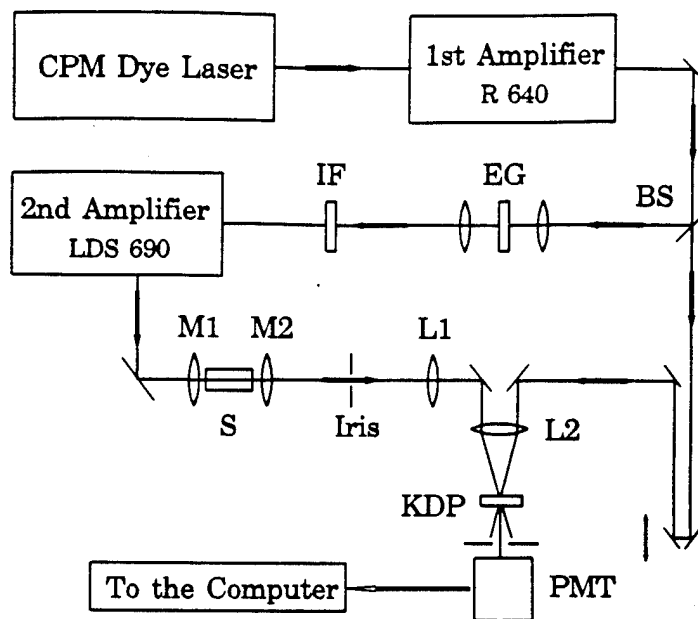

Figure 5. Experimental setup for the cross-correlation measurement. BS (50/50 beam splitter), EG (ethylene glycol jet), IF (interference filter), M1 (2.5X microscope objective lens), S (CdS quantum dot waveguide), M2 (5X microscope objective lens), L1 ($f = 30$ cm collimating lens), L2 ($f = 10$ cm focusing lens).

as a reference for the cross-correlation measurement, and the other beam was focused on the ethylene glycol jet to generate the white continuum. Using an interference filter, the test beam spectrum was selected at 687 nm for the pulse to be in the high transmission state, and was reamplified with the second stage amplifier. The full width at half maximum of the test beam was 110 fs. Then the test beam was end fired to the CdS quantum dot waveguide. The output surface of the sample was imaged on the iris to block the unguided light. The output of the waveguide and the reference beam were focused on the 300- μm -thick KDP crystal to sum the frequencies. The sum frequency signal was detected with a photomultiplier tube, varying the time delay on the reference beam.

The time and spectral profiles of the input and output pulses of the waveguide were measured and are shown in Fig. 6. For an intensity of 12 GW/cm², the pulse developed into 3 peaks after it propagated

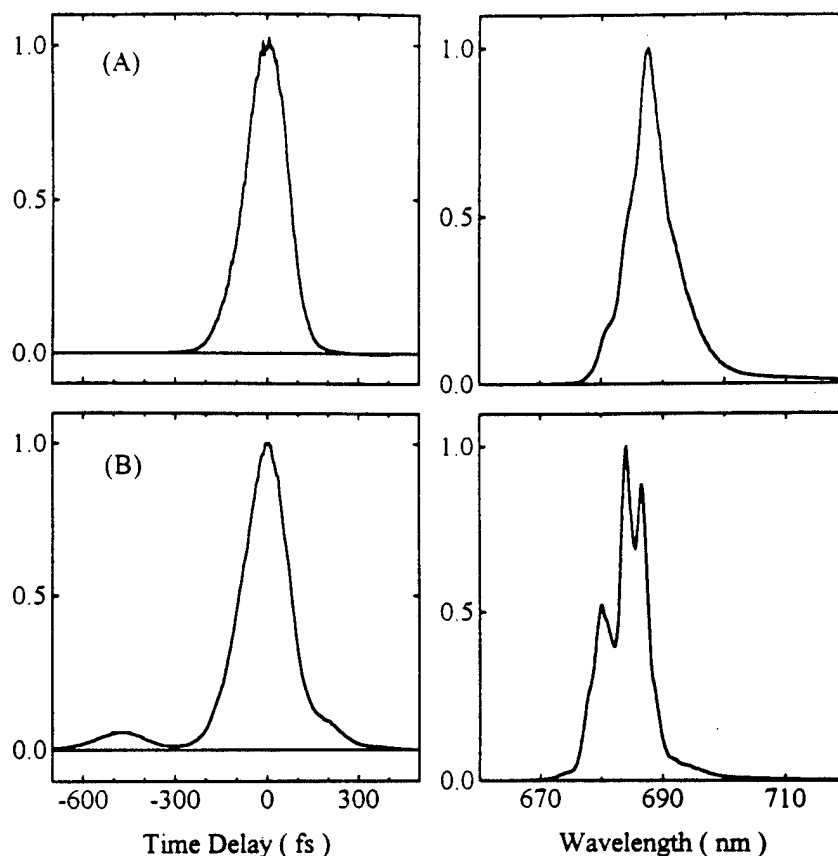

Figure 6. The cross correlation and spectrum of the femtosecond pulse after propagating 8-mm-long CdS quantum dot waveguide. (a) 110 fs input pulse profile and its spectrum. (b) The output pulse shape and spectrum with 12 GW/cm² input intensity.

through the CdS quantum dot waveguide with broadened and modulated spectrum. The origin of the pulse breakup is currently under investigation. It may be the result of either coherent effects⁶ or launching of a soliton in the quantum dot waveguides. For II-VI semiconductors dispersed in borosilicate glass, the nonlinear index of refraction, n_2 , is negative for photon energies below the bandgap and above half of the bandgap.^{7,8} The host glass material has normal group velocity dispersion for this wavelength region ($\lambda < 1.5 \mu\text{m}$). Therefore, it is possible in principle to generate solitons in semiconductor quantum dot waveguides.⁹ Additional experiments are needed to uniquely determine the origin of the pulse breakup.

We also succeeded in fabricating the first circular grating on one of our quantum dot slab waveguides for investigation of laser properties. This is very new and we have not had a chance to characterize it yet.

Publications for the Last Year

1. N. Peyghambarian, S. W. Koch, and A. Mysyrowicz, *Introduction to Semiconductor Optics* (Prentice Hall, Englewood Cliffs, NJ, 1993).
2. N. Peyghambarian, E. Hanamura, S. W. Koch, Y. Masumoto, and E. M. Wright, "Optical characterization and applications of semiconductor quantum dots," *Nanostructures Materials: Synthesis, Characterization, and Uses*, edited by A. S. Edelstein and H. Hahn (Adam Hilger Publ. Co., 1993).
3. N. Peyghambarian and L. Brus, "Interview on Quantum Dots," *OE Reports*, No. 112, April 1993, p. 1.
4. L. Banyai and S. W. Koch, *Semiconductor Quantum Dots* (World Scientific, Singapore, 1993).
5. K. I. Kang, A. D. Kepner, S. V. Gaponenko, S. W. Koch, Y. Z. Hu, and N. Peyghambarian, "Confinement-enhanced biexciton binding energy in semiconductor quantum dots," *Phys. Rev. B*, Nov. 15, 1993.
6. T. Takada, J. D. Mackenzie, M. Yamane, K. Kang, N. Peyghambarian, R. J. Reeves, F. T. Knobbe, and R. C. Powell, "Preparation and nonlinear optical properties of CdS quantum dots in $\text{Na}_2\text{O-B}_2\text{O}_3\text{-SiO}_2$ glasses by the sol-gel technique," submitted to *J. Opt. Soc. Am. B*.
7. S. G. Lee, K. I. Kang, P. Guerreiro, N. Peyghambarian, S. I. Najafi, G. Zhang, Y. Li, T. Takada, and J. Mackenzie, "Femtosecond pulse propagation in the ion-exchanged cadmium sulfide quantum dot waveguides," submitted to *Electron. Lett.*

8. K. Kang, A. D. Kepner, Y. Z. Hu, S. W. Koch, N. Peyghambarian, C. Y. Li, T. Takada, Y. Yao, and J. D. Mackenzie, "Room temperature spectral hole burning and elimination of photodarkening effect in sol-gel derived CdS quantum dots," submitted to Appl. Phys. Lett.
9. (invited paper) N. Peyghambarian, "Recent advances in nonlinear semiconductor quantum dots in glass," OSA Annual Meeting, Toronto, Canada, Oct. 3-8, 1993; Optics and Photonics News, Vol. 4, Nov. 7, 1993, p. 143.
10. (keynote address) N. Peyghambarian, "The application of nonlinear optical materials based on ultrafine particles," International Workshop on *Ultrafine Particles in Glass*, Nov. 10-11, 1992, Osaka, Japan.
11. (plenary talk) N. Peyghambarian, "Semiconductor quantum dots for optical data storage," Conference on Nonlinear and Quantum Optics, Rio de Janeiro, Brazil, Oct. 19-23, 1992.
12. (invited paper) N. Peyghambarian, K. I. Kang, A. D. Kepner, S. V. Gaponenko, Y. Z. Hu, and S. W. Koch, "Spectral hole burning and confinement-enhanced biexciton binding energy in semiconductor quantum dots," Proc. of Electrochemical Society Meeting, New Orleans, Louisiana, Oct. 10-15, 1993, paper #485.
13. K. Kang, Sandalphon, Y. Z. Hu, S. W. Koch, N. Peyghambarian, C. Li, T. Takada, J. Mackenzie, L. C. Liu, and S. H. Risbud, "Nonlinear optical properties of CdS quantum dots prepared by the solgel technique: spectral hole burning and photodarkening," Proc. CLEO '93, Baltimore, MD, May 2-7, 1993, paper CF17.
14. (invited paper) N. Peyghambarian, "Semiconductor quantum dots for optical storage and lasers," SPIE Conference on Sol-gel Technology, July 1993, San Diego, California.