



TECHNICAL REPORT  
NATICK/TR-94/008

AD \_\_\_\_\_

# Millisecond Pulse Generating System for a Continuous Wave CO<sub>2</sub> Laser

By

Brian R. Kimball, Gerald G. Caldarella,  
Barry S. DeCristofano and Joseph F. Roach

February 1994

Final Report

October 1993 - November 1993

Approved for public release, distribution unlimited

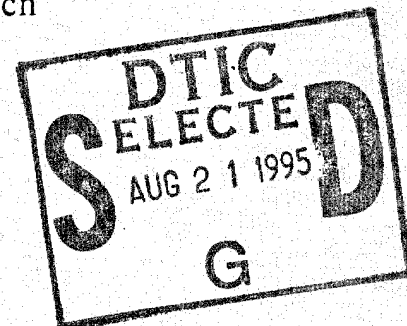

19950821 018

U.S. ARMY NATICK  
RESEARCH, DEVELOPMENT AND ENGINEERING CENTER  
NATICK, MASSACHUSETTS 01760-5000

SCIENCE AND TECHNOLOGY DIRECTORATE

## DISCLAIMERS

The findings contained in this report are not to be construed as an official Department of the Army position unless so designated by other authorized documents.

Citation of trade names in this report does not constitute an official endorsement or approval of the use of such items.

## DESTRUCTION NOTICE

### For Classified Documents:

Follow the procedures in DoD 5200.22-M, Industrial Security Manual, Section II-19 or DoD 5200.1-R, Information Security Program Regulation, Chapter IX.

### For Unclassified/Limited Distribution Documents:

Destroy by any method that prevents disclosure of contents or reconstruction of the document.

# REPORT DOCUMENTATION PAGE

Form Approved  
OMB No. 0704-0188

Public reporting burden for this collection of information is estimated to average 1 hour per response, including the time for reviewing instructions, searching existing data sources, gathering and maintaining the data needed, and completing and reviewing the collection of information. Send comments regarding this burden estimate or any other aspect of this collection of information, including suggestions for reducing this burden, to Washington Headquarters Services, Directorate for Information Operations and Reports, 1215 Jefferson Davis Highway, Suite 1204, Arlington, VA 22202-4302, and to the Office of Management and Budget, Paperwork Reduction Project (0704-0188), Washington, DC 20503.

1. AGENCY USE ONLY (Leave blank)	2. REPORT DATE <b>February 1994</b>	3. REPORT TYPE AND DATES COVERED <b>Final Oct 93 - Nov 93</b>	
4. TITLE AND SUBTITLE <b>MILLISECOND PULSE GENERATING SYSTEM FOR A CONTINUOUS WAVE CO<sub>2</sub> LASER</b>		5. FUNDING NUMBERS <b>AgC: TB 1257 PE: G2796 PR: 1L1AH98 TA: CAB00</b>	
6. AUTHOR(S) <b>Brian R. Kimball, Gerald G. Caldarella, Barry S. DeCristofano, and Joseph F. Roach</b>		8. PERFORMING ORGANIZATION REPORT NUMBER <b>NATICK/TR-94/008</b>	
7. PERFORMING ORGANIZATION NAME(S) AND ADDRESS(ES) <b>U.S. Army Natick Research, Development and Engineering Center Kansas Street ATTN: SATNC-YSD Natick, MA 01760-5020</b>		10. SPONSORING / MONITORING AGENCY REPORT NUMBER	
9. SPONSORING / MONITORING AGENCY NAME(S) AND ADDRESS(ES)		11. SUPPLEMENTARY NOTES	
12a. DISTRIBUTION / AVAILABILITY STATEMENT  <b>Approved for public release, distribution unlimited</b>		12b. DISTRIBUTION CODE	
13. ABSTRACT (Maximum 200 words)  <b>A system has been developed for generating single millisecond pulses and pulse trains with a continuous wave industrial CO<sub>2</sub> laser while simultaneously measuring the corresponding irradiance with calorimeters that have a 0.5 s response time. First area moment equations are derived and used to balance the inertia forces of a continuously variable-angle chopper blade used in the system. The results of a study to determine calorimeter response time, investigate system accuracy, and demonstrate systems use are also presented.</b>			
14. <del>CONTINUOUS WAVE</del> <b>CONTINUOUS WAVE LASER CALORIMETERS</b>		<b>MILLISECOND PULSES PULSE TRAINS CO<sub>2</sub> LASERS LIGHT CHOPPERS</b>	
17. SECURITY CLASSIFICATION OF REPORT <b>Unclassified</b>		15. NUMBER OF PAGES <b>27</b>	
18. SECURITY CLASSIFICATION OF THIS PAGE <b>Unclassified</b>		16. PRICE CODE	
19. SECURITY CLASSIFICATION OF ABSTRACT <b>Unclassified</b>		20. LIMITATION OF ABSTRACT	

*THIS STATEMENT UNCLASSIFIED*

TABLE OF CONTENTS

LIST OF FIGURES	iv
PREFACE	v
INTRODUCTION	1
SYSTEM DESIGN	1
Design Considerations	1
Chopper Blade Design	2
MILLISECOND PULSE GENERATING SYSTEM DEMONSTRATION:	
CALORIMETER RESPONSE TIME	8
Experimental Procedure	8
RESULTS	10
CONCLUSIONS AND RECOMMENDATIONS	11
REFERENCES	12
APPENDIX	
Calorimeter Temporal Response Curves	13
DISTRIBUTION LIST	18

Accession For	
NTIS CRA&I	<input checked="" type="checkbox"/>
DTIC TAB	<input type="checkbox"/>
Unannounced	<input type="checkbox"/>
Justification _____	
By _____	
Distribution /	
Availability Codes	
Dist	Avail and/or Special
A-1	

## LIST OF FIGURES

<u>Figure</u>	<u>Page</u>
1. Location of Copper Blade After Beam Splitter For the Production and Measurement of Millisecond Pulses.	2
2. General Segment Used in Derivation of First Area Moment Expressions.	4
3. Balanced Chopper Blade Part A.	6
4. Balanced Chopper Blade Part B.	7
5. Normalized Calorimeter Output Voltage Vs Time For a 5 s Pulse.	8
6. General Profile of Laser Pulse Created by Water-Cooled Shutter in Laser Head.	10
A-1. Normalized Voltage Vs Time For a 10 ms Primary Pulse and a 500 ms Secondary Pulse.	14
A-2. Normalized Voltage Vs Time For a 50 ms Primary Pulse and a 500 ms Secondary Pulse.	14
A-3. Normalized Voltage Vs Time For a 100 ms Primary Pulse and a 500 ms Secondary Pulse.	15
A-4. Normalized Voltage Vs Time For a 200 ms Primary Pulse and a 1.30 s Secondary Pulse.	15
A-5. Normalized Voltage Vs Time For a 300 ms Primary Pulse and a 1.30 s Secondary Pulse.	16
A-6. Normalized Voltage Vs Time For a 400 ms Primary Pulse and a 1.30 s Secondary Pulse.	16
A-7. Normalized Voltage Vs Time For a 500 ms Primary Pulse and a 1.30 s Secondary Pulse.	17

## PREFACE

This report summarizes the design and use of a new system which has been developed for the production and measurement of CO<sub>2</sub> laser pulses in the millisecond range. This work is being done under the project Thermal Protection, 1L162786AH98CABOO, administered by the Technology Application Branch (TAB), Fiber and Polymer Science Division, Science and Technology Directorate, U.S. Army Natick Research, Development, and Engineering Center.

All experiments were performed at the Technology Application Branch, at the U.S. Army Natick Research, Development, and Engineering Center (Natick). The citation of trade names in this report does not constitute official endorsement or approval of use of an item.

MILLISECOND PULSE GENERATING SYSTEM  
FOR A CONTINUOUS WAVE CO<sub>2</sub> LASER

INTRODUCTION

Thermal testing at the Science and Technology Directorate's Technology Application Branch (TAB) is currently being performed with an 820EP Spectra-Physics continuous wave CO<sub>2</sub> laser. The laser operates at a wavelength of 10.6  $\mu\text{m}$  with a maximum output power of 2.5 kW. Single pulses are created via a water-cooled mechanical shutter located in the laser head. Experiments performed at the TAB<sup>1</sup> for the purpose of documenting the temporal characteristics of the shutter show that the minimum pulse width is about 100 ms. This study also shows that the open and close time of the shutter varies greatly. Though the average absolute deviation was 50 ms as stated by the manufacturer, random variations were observed ranging from 25 ms to 85 ms. These variations are substantial in the 100 ms range but become less so as the pulse width increases above 500 ms.

A mechanical variable frequency light chopper is available and has been used for the production of millisecond pulses. However, the calorimeters being used have a 0.5 s response time, and while it has been possible to create millisecond pulses, we have not been able to measure the corresponding irradiance.

In order to extend our pulse-creating capabilities into the millisecond range, a new system was developed that utilizes a set of two individually balanced blades, which can be set to create a continuously variable gap ranging from 0° to 170°. The problem of calorimeter response time is overcome by locating the chopper after the beam splitter (Fig. 1). This allows one to record the irradiance of the entire pulse emitted through the laser head shutter, at a location before that where the pulse is chopped. The period of rotation of the chopper is set equal to or greater than 500 ms -- the minimum pulse width that can be accurately measured by the calorimeter in the secondary beam. The variable gap is set to that angle, which will result in the desired pulse width at the target in the primary beam. This paper summarizes the design and application of the new system.

SYSTEM DESIGN

Design Considerations

The variable angle chopper blade was designed to be mounted on a commercial variable frequency light chopper assembly (Princeton Applied Research, Model 192). Design parameters include compatibility with mount

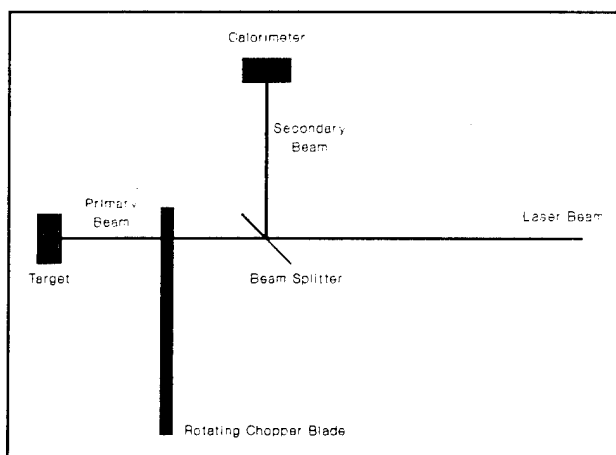

Fig. 1. Location of Chopper Blade After Beam Splitter For the Production and Measurement of Millisecond Pulses.

dimensions, laser beam diameter, and rotating speed.

The blade mount will accommodate a 4.062 inch radius blade. Beam diameter requires a beam stop and gap dimension of at least 0.75 inch. The chopper assembly operates over a range of 2.5 - 100 volts relating to 2.5 - 100 rps. It is possible to obtain speeds outside this range by applying an external voltage source. The external voltage adds to the assembly voltage. An applied negative voltage will reduce the rps. This is necessary to increase the period of rotation to greater than 0.5 s in order to accommodate calorimeter response time. The low rotational speed, however, implies a low angular momentum, thus causing the stator and rotor of the electric motor to become "unlocked". The blade then ceases to rotate at a constant angular velocity making it difficult to set the necessary combination of blade gap angle and rotating speed for a desired pulse width. This problem can be minimized by balancing the inertia forces of the blade. A balanced blade will also operate with less vibration at high speed.

#### Chopper Blade Design

The variable angle chopper blade consists of two individual blades, which can be set to create a desired gap angle. In order that the double blade assembly be balanced in any configuration, each blade must be individually balanced.

Static- or single-plane balancing is all that is required in this case because the axial dimension (0.125 inch) of the blade assembly is small compared to the radial dimension. This type of balancing is generally used with fly wheels, gears, etc.

In order for a moving system to be balanced, all forces acting on the system must sum to zero. Using the method of d'Alembert, Newton's second law is written in the form

$$\sum \mathbf{F} - m\mathbf{a} = 0. \quad (1)$$

External forces are neglected here because they cannot be balanced by changes in system geometry. Each plate is divided into segments. Each segment is imagined to be a point mass centered at the segment's center of gravity. For a rotating system at constant angular velocity the inertial forces are given by the general expression

$$- m_1 R_1 \omega_1^2 - m_2 R_2 \omega_2^2 - \dots - m_n R_n \omega_n^2 = 0, \quad (2)$$

where  $m$  is the mass of the segment,  $\omega$  is the angular velocity and  $R$  is the radial distance to the center of gravity of the segment. The negative sign indicates the force is acting in a direction away from the system pivot.  $\omega$  is constant in Eq. 2 and can be divided out. The mass is obtained with the expression

$$m = \rho A t, \quad (3)$$

where  $\rho$  is the density of the material,  $A$  is the area of the segment, and  $t$  is the thickness.  $\rho$  is constant as is the blade thickness. With these considerations Eq. 2 becomes

$$- R_1 A_1 - R_2 A_2 - \dots - R_n A_n = 0. \quad (4)$$

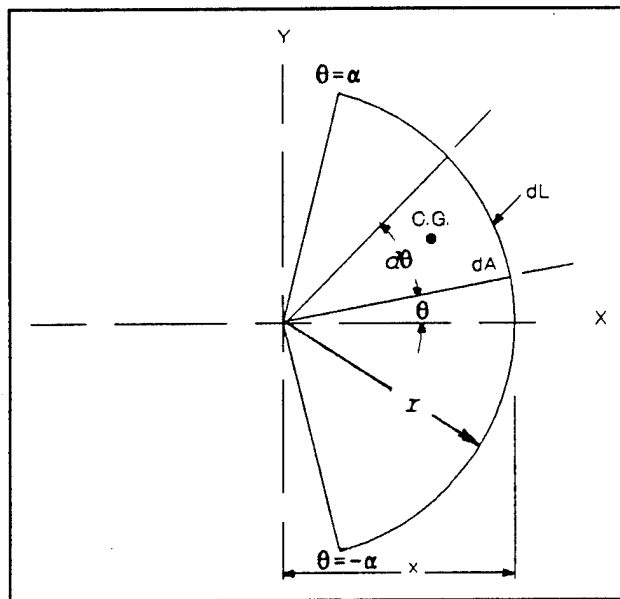

Fig. 2. General Segment Used in Derivation of First Area Moment Expressions.

The product  $R_n A_n$  in the previous equation is the first area moment of inertia with respect to some arbitrary axis. We need expressions for both  $A_n$  and  $R_n$ . Referring to Fig. 2 we can write

$$A = \int_{-\alpha}^{\alpha} dA = \alpha r^2. \quad (5)$$

The first moment with respect to the y axis can be obtained from the expression

$$Q_y = \int R_{x_{el}} dA = R_{\bar{x}} A, \quad (6)$$

where  $R_{x_{el}}$  is the distance along the x axis to the center of gravity of the element and  $R_{\bar{x}}$  is the distance to the center of gravity of the entire segment. From Fig. 2 we have

$$dA = \frac{1}{2} r^2 d\theta, \quad (7)$$

$$dL = r d\theta, \quad (8)$$

and

$$x = r \cos\theta. \quad (9)$$

In the limit as  $\theta \rightarrow 0$ , the element in Fig. 2 closely approximates a triangle. We can therefore write

$$R_{\bar{x}_{el}} = \frac{2}{3} r \cos\theta. \quad (10)$$

Combining Eqs. 7-10 with Eq. 6 we obtain

$$Q_y = \int_{-\alpha}^{\alpha} \frac{1}{3} r^3 \cos\theta d\theta = \frac{2}{3} r^3 \sin\alpha = R_{\bar{x}} A. \quad (11)$$

Combining Eq. 11 with Eq. 5 and solving for  $R_{\bar{x}}$ , an expression is obtained for the radial distance to the segment's center of gravity as a function of the segment radius and angle

$$R_{\bar{x}} = \frac{2}{3} \frac{r \sin\alpha}{\alpha}. \quad (12)$$

This expression is then used with Eq. 4 to balance each blade.

Assigning an axis through the center of each blade and taking advantage of geometrical symmetry, Eq. 4 was solved with dimensions that conform to the previously stated physical constraints of maximum blade diameter and beam width. Note that holes are created by subtracting and adding appropriate segments. For example, in order to create a 1-inch radial hole that subtends an angle of  $30^\circ$  in a 6-inch radius blade, one would define the first area moment of inertia of a  $30^\circ$  degree segment of radius 6 inches, subtract from it the first area moment of inertia of a  $30^\circ$  segment of radius 5 inches, then add the first area moment of inertia of a  $30^\circ$  segment of radius 4 inches. The final blade designs are shown in Figs. 3 and 4.

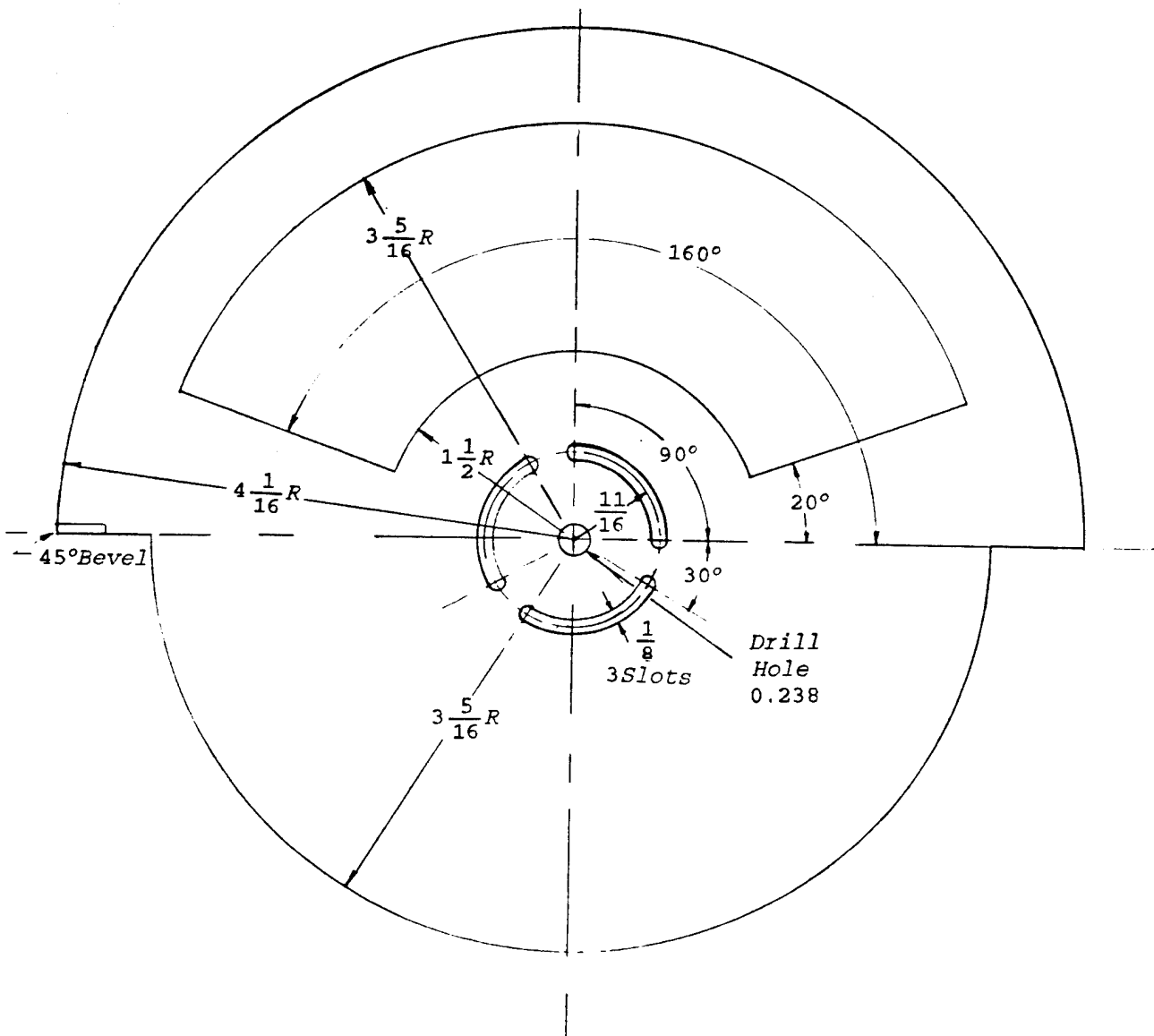

Fig. 3. Balanced Chopper Blade Part A.

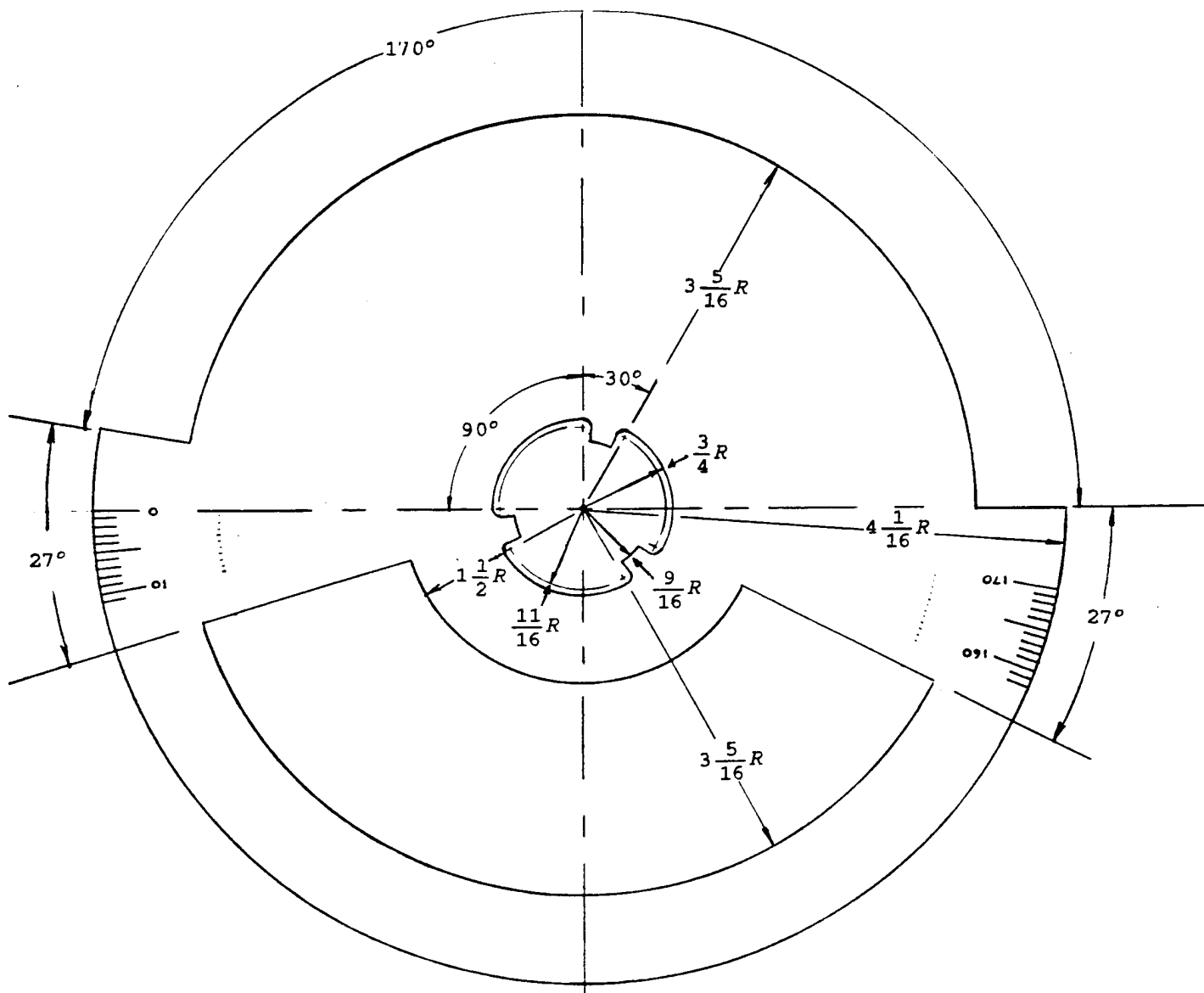

Fig. 4. Balanced Chopper Blade Part B.

MILLISECOND PULSE GENERATING SYSTEM (MPGS) DEMONSTRATION:  
CALORIMETER TEMPORAL RESPONSE

In order to demonstrate the use of the MPGS, a study was performed where a series of pulses ranging from 10 ms to 500 ms were created with the system. The study shows the accuracy that can be obtained in producing pulses in the millisecond range and quantifies the minimum pulse width necessary to obtain accurate irradiance measurements. It also gives additional relevant information concerning the temporal response of the calorimeters<sup>2</sup> currently being used in our thermal studies.

Experimental Procedure

The experimental setup is identical to that shown in Fig. 1 with the exception that the target is replaced with a second calorimeter. We then have a calorimeter in the secondary beam, which registers the irradiance of the pulse emitted through the water-cooled shutter in the laser head, and a calorimeter in the primary beam, which registers the pulse generated by the rotating chopper blade. By incrementally increasing the pulse length at the primary beam and comparing it to a previously designated ratio of primary to secondary beam, we eventually arrive at the minimum pulse length required to obtain accurate irradiance measurements.

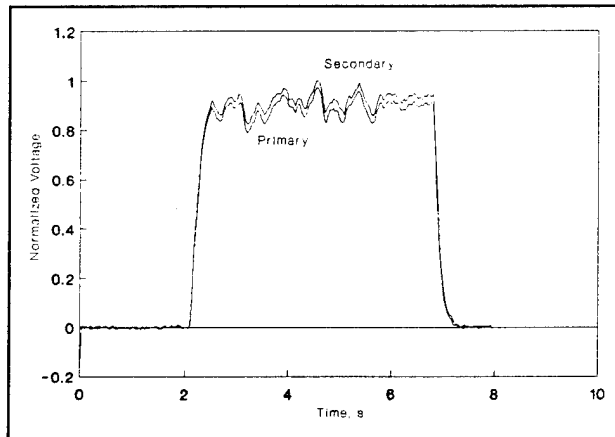

Fig. 5. Normalized Calorimeter Output Voltage Vs Time For a 5 s Pulse.

The average ratio of primary to secondary calorimeter voltage was obtained by recording a 5 s pulse generated by the laser-head shutter. Normalized output voltage vs time for this run is shown in Fig. 5. The ratio is calculated to be 0.96.

In order to determine the gap angle at which the blade system must be set, a preliminary run is conducted--in this case with the speed control set at 2.5 rps. A photodetector mounted in the assembly produces an alternating 0 to 5 volt output, which is used to determine the actual angular speed. An angular speed of 2.5 rps relates to a period of rotation of 0.4 s. For 10 ms, 50 ms, and 100 ms pulses, the blade gap must be set at 9°, 45°, and 90°, respectively. To create longer pulses with the system, the period of rotation is increased and determined in the same fashion. In this case, for pulses of 200 ms, 300 ms, 400 ms, and 500 ms at the primary beam, a period of rotation of 1.22 s was used, and gap angles were set at 59°, 89°, 118°, and 148°, respectively. These results are summarized in Table 1.

Table 1. Results of Study to Determine Temporal Characteristics of Calorimeters.

Desired Pulse (ms)	Angular Gap	Period of Rotation (s)	Pulse at Secondary Beam (s)	Actual Period of Rotation (s)	Actual Pulse (ms)	Percent Error
10	9°	0.4	0.5	0.398	9.95	0.5%
50	45°	0.4	0.5	0.397	49.6	0.8%
100	90°	0.4	0.5	0.402	100.5	0.5%
200	59°	1.22	1.3	1.18	193	3.5%
300	89°	1.22	1.3	1.20	296	1.4%
400	118°	1.22	1.3	1.17	382	4.5%
500	148°	1.22	1.3	1.22	502	0.3%

The desired pulse widths shown in column 1 are created by setting the gap of the blade system to an angle (column 2) based on the experimentally predetermined period of rotation given in column 3. The water-cooled laser shutter speed (column 4) is set to a value slightly greater than the period of rotation of the blade and the response time of the calorimeter. Three channels of data were recorded for this experiment; the output voltage of each calorimeter and the photodetector output from which the actual period of rotation (column 5) was determined. If it is assumed that the gap angle can be set with negligible error, then the actual pulse width (column 6) can be determined with the actual period of rotation data. The percent errors given in column 7 compare the desired pulse width to the actual.

## RESULTS

Plots were generated for each of the 7 runs documented in Table 1. These are shown in the Appendix in Figs. A-1 to A-7. In each plot normalized output voltage is shown for both the primary and secondary calorimeters. These plots should be compared to Fig. 5. In Fig. A-1 it can be seen that the primary calorimeter has barely responded to the 10 ms pulse, giving an output voltage signal which is less than 10% of that which corresponds to the actual irradiance incident on the calorimeter. For each consecutive run, as the pulse width at the primary beam is increased, the output voltage of the primary calorimeter begins to represent more closely that of the actual irradiance level. At 500 ms (Fig. A-7) the primary calorimeter just begins to give accurate readings approaching the ratio shown in Fig. 5, and confirming the manufacturer's stated response time of 0.5 s.

Clearly, the greater the pulse width at the secondary calorimeter, the greater the accuracy of the irradiance measurement. The general pulse shape is shown in Fig. 6. The ramp up and ramp down portions of the pulse are due to a combination of 1) the time required for the shutter to open and close and 2) the response time of the calorimeter. In a similar study<sup>3</sup> it was determined that the most accurate readings can be obtained by averaging over that portion of the pulse beginning at point C that is generally well defined and counting back to point B, which is 0.5 s into the pulse; this eliminates the ramp up and ramp down portions of the pulse profile.

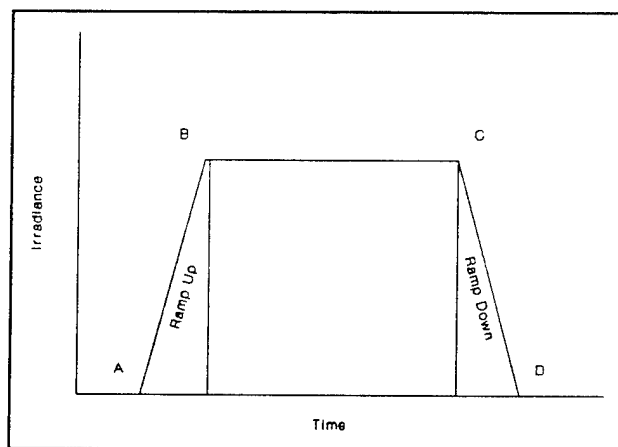

Fig. 6. General Profile of Laser Pulse Created by Water-Cooled Shutter in Laser Head.

## CONCLUSIONS AND RECOMMENDATIONS

A new millisecond pulse generating system has been developed, constructed, and implemented using a set of chopper blades fabricated at Natick and additional equipment currently available in our laboratory. Design considerations were summarized and expressions were derived that were used in the design of a balanced chopper blade system capable of creating single pulses or pulse trains in the millisecond range. System accuracy was investigated and found to be acceptable for our purposes. Errors of less than 5% were demonstrated in achieving a desired pulse width and negligible errors (< 0.5%) were encountered in determining the actual pulse width when a high sampling rate (~1000 Hz) was used in data acquisition.

In addition, the temporal characteristics of the calorimeters that we are currently using were investigated. A 0.5 s calorimeter response time was determined and the proper irradiance measurement technique was discussed.

Future work should be directed at determining the possible combinations of pulse widths and periods which can be obtained with the system when it is used to create pulse trains. The incorporation of pulse trains into our standard fabric testing procedures should be considered as well as the use of the system in industrial applications.

The millisecond pulse generating system has performed as designed and will significantly extend our capabilities in the area of thermal testing.

#### REFERENCES

1. Laboratory Notebook #9114, U.S. Army Natick Research, Development and Engineering Center, September 30, 1993, pp. 133-4.
2. Hy-Cal Engineering, 12105 Los Nietos Road, Santa Fe Springs, California, model C-1112-B-60-120.
3. Laboratory Notebook #9114, U.S. Army Natick Research, Development and Engineering Center, March 19, 1993, pp. 63-8.

APPENDIX

Calorimeter Temporal Response Curves

10 ms Primary, 500 ms Secondary

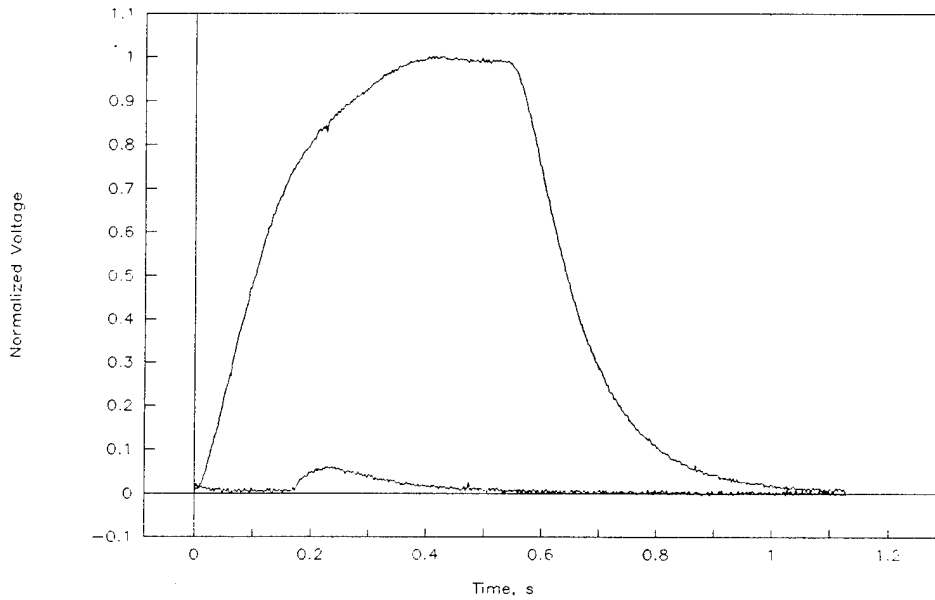

Fig. A-1. Normalized Voltage Versus Time For 10 ms Primary Pulse and 500 ms Secondary Pulse.

50 ms Primary, 500 ms Secondary

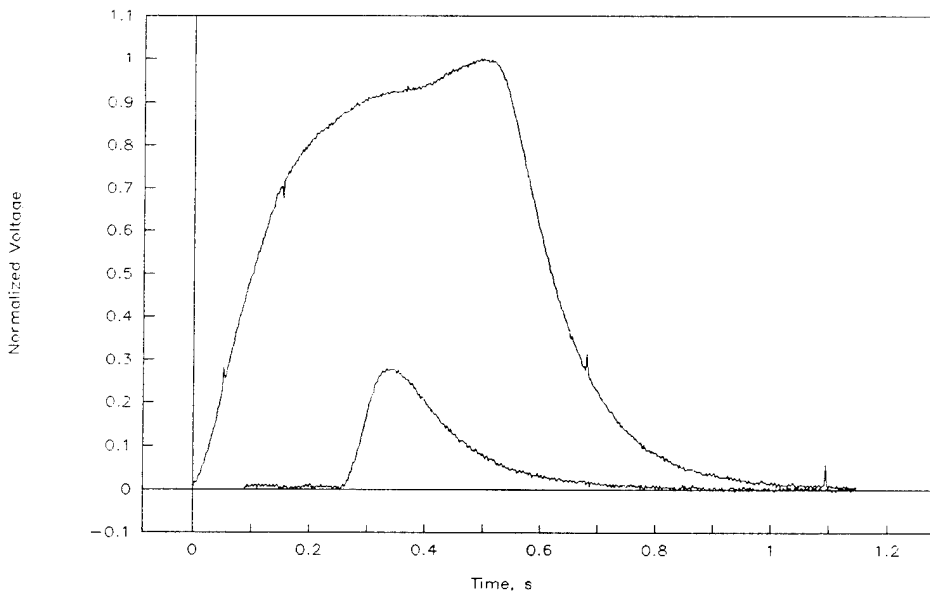

Fig. A-2. Normalized Voltage vs Time For 50 ms Primary Pulse and 500 ms Secondary Pulse.

100 ms Primary, 500 ms Secondary

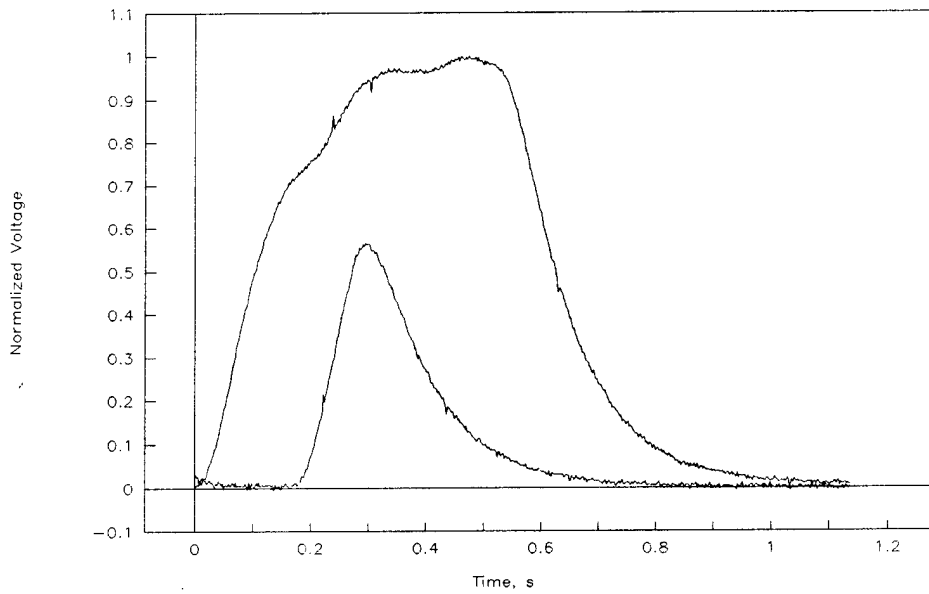

Fig. A-3. Normalized Voltage vs Time For a 100 ms Primary Pulse and 500 ms Secondary Pulse.

200 ms Primary, 1.30 s Secondary

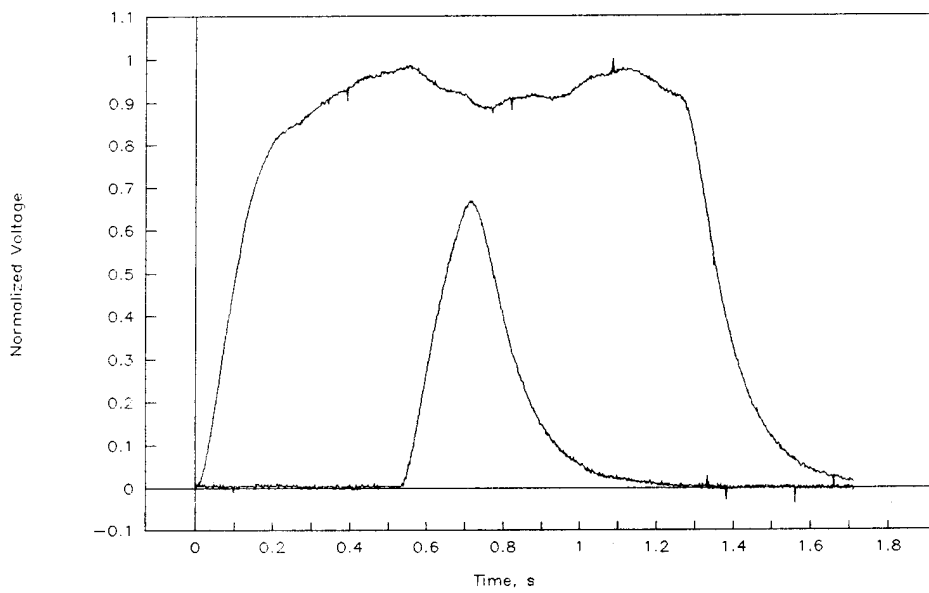

Fig. A-4. Normalized Voltage Vs Time For a 200 ms Primary Pulse and 1.30 s Secondary Pulse.

300 ms Primary, 1.30 s Secondary

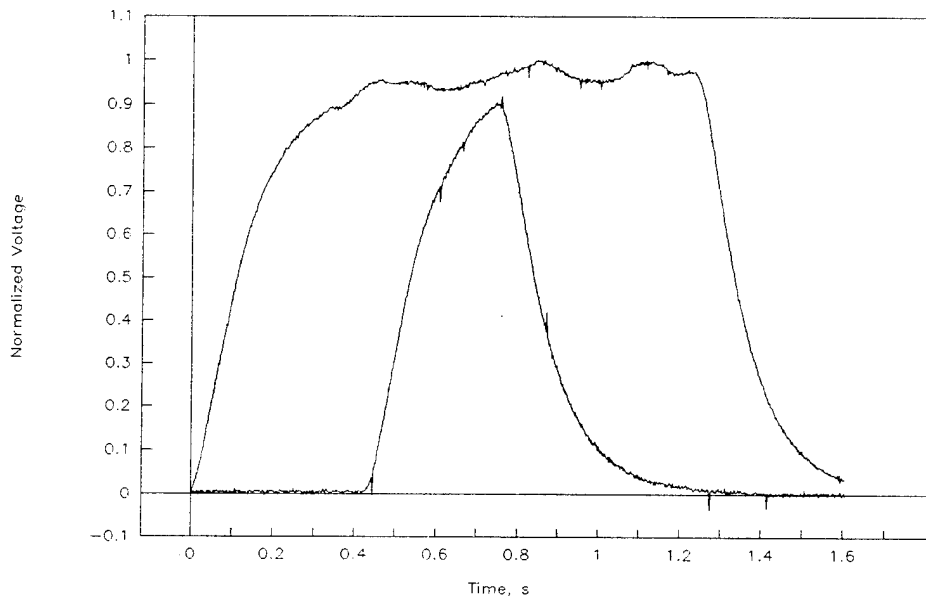

Fig. A-5. Normalized Voltage vs Time For 300 ms Primary Pulse and and 1.30 s Secondary Pulse.

400 ms Primary, 1.30 s Secondary

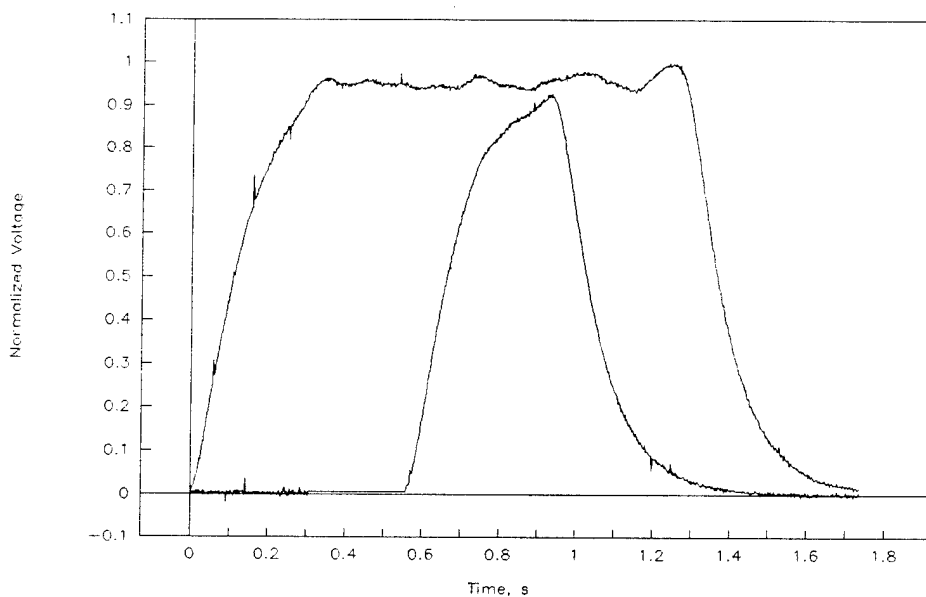

Fig. A-6. Normalized Voltage Vs Time For 400 ms Primary Pulse and 1.30 s Secondary Pulse.

500 ms Primary, 1.30 s Secondary

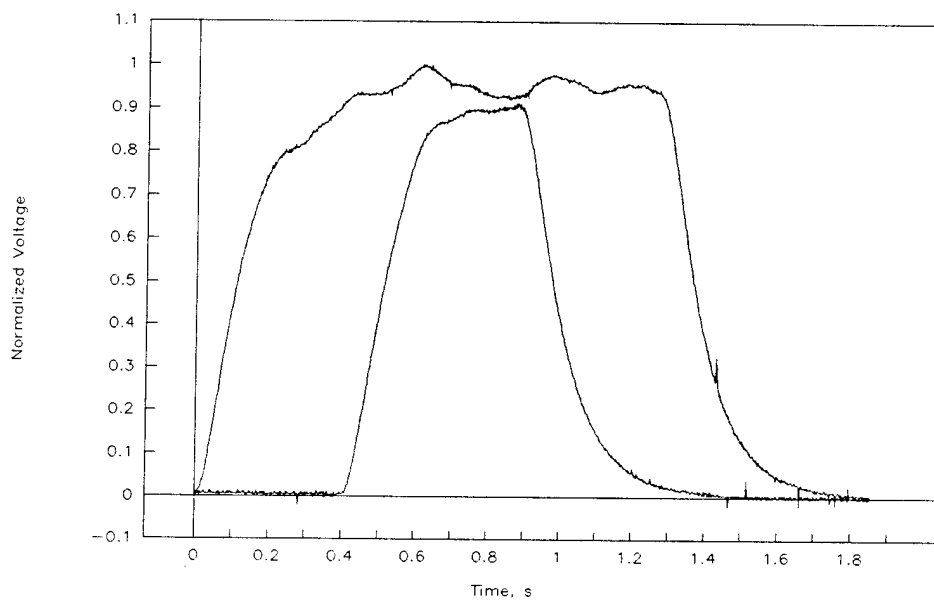

Fig. A-7. Normalized Voltage Vs Time For 500 ms Primary Pulse and 1.30 s Secondary Pulse.

DISTRIBUTION LIST

1 copy to:

COMMANDER  
U.S. ARMY TRAINING AND DOCTRINE  
COMMAND  
ATTN: ATCD-SE  
FT. MONROE, VA 23651

1 copy to:

PROGRAM MANAGER - CLOTHING AND  
INDIVIDUAL EQUIPMENT  
ATTN: AMCPM-CIE  
WOODBIDGE, VA 22194-4206

1 copy to:

COMMANDANT  
U.S. ARMY INFANTRY SCHOOL  
ATTN: ATSH-CD-MLS-C  
FT. BENNING, GA 31905

1 copy to:

COMMANDANT  
U.S. ARMY ARMOR SCHOOL  
ATTN: ATSB-CD-ML  
FT. KNOX, KY 40121-5215

1 copy to:

COMMANDANT  
U.S. ARMY CHEMICAL SCHOOL  
ATTN: ATZN-CM-CS  
FT. McCLELLAN, AL 36205-5000

1 copy to:

COMMAMDANT  
U.S. ARMY AVIATION SCHOOL  
ATTN: ATZQ-CDM-C  
FT. RUCKER, AL 36362

1 copy to:

COMMANDER  
U.S. ARMY NUCLEAR AND  
CHEMICAL AGENCY  
ATTN: MONA-NU BLDG. 2073  
7500 BACKLICK ROAD  
SPRINGFIELD, VA 22150-3198

1 copy to:

COMMANDER  
U.S. ARMY NUCLEAR AND  
CHEMICAL AGENCY  
ATTN: MONA-ZB BLDG.2073  
7500 BACKLICK ROAD  
SPRINGFIELD, VA 22150-3198

1 copy to:

DIRECTOR  
DEFENSE NUCLEAR AGENCY  
ATTN: TDTR  
6801 TELEGRAPH ROAD  
ALEXANDRIA, VA 23310-3398

1 copy to:

DIRECTOR  
DEFENSE NUCLEAR AGENCY  
ATTN: HRP  
6801 TELEGRAPH ROAD  
ALEXANDRIA, VA 23310-3398

1 copy to:

HQDA  
OFFICE OF THE SURGEON GENERAL  
ATTN: DASG-HCG  
5109 LEESBURG PIKE  
FALLS CHURCH, VA 22041-3258

1 copy to:

COMMANDER  
U. S. ARMY COMBINED ARMS DEFENSE CENTER  
ATTN: ATZL-CAD-N  
FT. LEAVENWORTH, KS 66027-5300

1 copy to:

U.S. ARMY AVIATION MEDICAL RESEARCH  
LABORATORY  
ATTN: SGRD-VAB-CB  
FT. RUCKER, AL 36352-5000

1 copy to:

COMMANDER  
WALTER REED INSTITUTE OF RESEARCH  
ATTN: SGRD-UWZ  
WASHINGTON, DC 20307-5100

1 copy to:

U.S. ARMY RESEARCH LABORATORY  
ATTN: SLCHD-NW-TN  
2800 POWDER MILL ROAD  
ADELPHI, MD 20783

1 copy to:

U.S. NAVY CLOTHING AND TEXTILE  
RESEARCH FACILITY  
ATTN: CODE 40.1  
21 STRATHMORE ROAD  
NATICK, MA 01760-2490

2 copies to:

DEFENSE TECHNICAL INFORMATION CENTER  
CAMERON STATION  
ALEXANDRIA, VA 22314

7 copies to:

COMMANDER  
U.S. ARMY NATICK RD & E CENTER  
TECHNICAL LIBRARY  
ATTN: STRNC-MIL  
NATICK, MA 01760

1 copy to:

COMMANDER  
U.S. ARMY NATICK RD & E CENTER  
ATTN: STRNC-MSR  
NATICK, MA 01760-5020

50 copies to:

COMMANDER  
U.S. ARMY NATICK RD & E CENTER  
ATTN: STRNC-YSD (Mr. Kimball)  
NATICK, MA 01760-5020