

REPORT DOCUMENTATION PAGE			Form Approved OMB No. 0704-0188	
1. AGENCY USE ONLY (leave blank)	2. REPORT DATE April, 1995	3. REPORT TYPE AND DATES COVERED Final, 5 Sept. 1991 to 4 Sept. 1994		
4. TITLE AND SUBTITLE Hydrogen Migration and Complex Formation in Technologically Important III-V and II-VI Semiconductors and Their Alloys		5. FUNDING NUMBERS (c) F49620-91-C-0082 (PR)-2306/B1 2305/ES 61102F		
6. AUTHOR(S) N. M. Johnson				
7. PERFORMING ORGANIZATION NAME(S) AND ADDRESS(ES) Xerox Palo Alto Research Center 3333 Coyote Hill Road Palo Alto, CA 94304				
9. SPONSORING/MONITORING AGENCY NAME(S) AND ADDRESS(ES) Air Force Office of Scientific Research Bolling Air Force Base Washington, D. C. 20332		8. PERFORMING ORGANIZATION REPORT NUMBER AFOSR-TR-91-0273		
10. SPONSORING/MONITORING AGENCY REPORT NUMBER F49620-91-C-0082		11. SUPPLEMENTARY NOTES		
12a. DISTRIBUTION/AVAILABILITY STATEMENT Approved for public release, distribution unlimited.				
13. ABSTRACT (Maximum 200 words) Experimental and theoretical studies were conducted to identify basic mechanisms and provide quantitative information on the properties of hydrogen in selected (technologically-important) III-V and II-VI semiconductors and their alloys. Hydrogen interactions with dopants and deep level defects were investigated in GaAs, AlGaAs, InGaAs/AlGaAs quantum wells, GaP, GaN, and ZnSe. The diffusivity of H ⁺ in GaAs was determined with a new capacitance transient technique, which provided the first direct quantitative determination of the diffusivity of hydrogen in any compound semiconductor. Vibrational mode spectroscopy identified the N-H complex in ZnSe:N and the Zn-H complex in GaP:Zn. Hydrogenation of Mg-doped GaN produced acceptor passivation. New local vibrational modes were detected in MBE-grown, Mg-doped GaN. Computational studies were conducted on native defects in GaN with the conclusion that, contrary to a wide-spread assumption, the nitrogen vacancy cannot be the source of the high n-type conductivity generally found in as-grown undoped GaN. Electronic defects were characterized in n-type GaN by deep level transient spectroscopy (DLTS) and optical-DLTS. Finally, in epitaxial ZnSe the effects of hydrogenation during gas-source (e.g., H ₂ Se) MBE were found to be significantly enhanced when N was used as the acceptor dopant and resulted in highly resistive films, while Cl-doped n-type films were largely unaffected by the presence of hydrogen during growth.				
14. SUBJECT TERMS hydrogen, III-V semiconductors, II-VI semiconductors, impurity-hydrogen complexes, deep levels and defects in GaN		15. NUMBER OF PAGES 33		
17. SECURITY CLASSIFICATION OF REPORT unclassified		16. PRICE CODE		
18. SECURITY CLASSIFICATION OF THIS PAGE unclassified	19. SECURITY CLASSIFICATION OF ABSTRACT unclassified	20. LIMITATION OF ABSTRACT		

19950615 013

TABLE OF CONTENTS

	page
Executive Summary	ii
List of Figures	vi
I. Introduction	1
II. Local Vibrational Modes in Hydrogenated, Mg-doped GaN	2
III. Computational Studies of Native Defects and Doping in GaN	5
IV. Deep Level Transient Spectroscopy on n-type GaN	7
V. Photoemission Capacitance Transient Spectroscopy on n-type GaN	8
VI. Local Vibrational Modes in Hydrogenated GaP:Zn	10
VII. Hydrogen Passivation of Dopants in ZnSe	12
VIII. Observations on the Limits to p-type Doping in ZnSe	14
References	16
Appendix I. List of Professional Personnel	18
Appendix II. List of Publications	22
Appendix III. List of Presentations	28

Accession For	
NTIS CRA&I	<input checked="" type="checkbox"/>
DTIC TAB	<input type="checkbox"/>
Unannounced	<input type="checkbox"/>
Justification	
By	
Distribution /	
Availability Codes	
Dist	Avail and/or Special
A-1	

Executive Summary

Over the period from 5 September 1991 to 4 September 1994, a program of research was conducted for the U.S. Air Force Office of Scientific Research (Contract # F49620-91-C-0082) on hydrogen in selected, technologically-important III-V and II-VI semiconductors and their alloys. Both experimental and theoretical studies were conducted to identify basic mechanisms and provide quantitative information on the properties of hydrogen in these semiconductors. The information will help to establish a fundamental basis for predicting, controlling, and optimizing the chemical effects of hydrogen in these materials.

During the first year of the program the emphasis was on GaAs and AlGaAs, although studies were also conducted on another III-V alloy (InAlAs) and on a multiquantum well structure (InGaAs/AlGaAs). In addition, work was initiated on wide-band-gap II-VI semiconductors. The following thermal dissociation energies of hydrogen-impurity complexes were determined: 1.2 ± 0.1 eV for the Si-H complex in GaAs:Si, 1.18 ± 0.06 eV for the Si-H complex in AlGaAs:Si, 1.15 ± 0.06 eV for the DX_{Si}-H deep-level center in AlGaAs:Si, 1.48 ± 0.07 eV for the Se-H complex in AlGaAs:Se, and 1.54 ± 0.08 eV for the DX_{Se}-H center in AlGaAs. It was further demonstrated with deep-level transient spectroscopy and photoluminescence (PL) that the two Cu-related deep levels in GaAs, at $E_V + 0.13$ eV and $E_V + 0.40$ eV, can be hydrogen passivated and that the Cu-related donor-acceptor pair luminescence at 1.36 eV correlates with the level at $E_V + 0.13$ eV. In our theoretical endeavors, first principles spin-density-functional calculations were performed for neutral hydrogen in GaAs and confirmed the antibonding site near an As atom as the global energy minimum for H⁰ in GaAs. Hydrogen passivation of InGaAs/AlGaAs quantum wells was observed to improve PL properties, with the effect being ascribed to passivation of interfacial defects. In ZnSe, hydrogen passivation was achieved by using a deposited SiO₂ layer to prevent decomposition during hydrogenation. By this means, it was

demonstrated that hydrogen incorporation in ZnSe epilayers is accompanied by selective passivation of commonly-observed donor-acceptor pair transitions as detected by PL.

During the second year of the program, in addition to continuing certain systematic studies that were initiated during the first year, we successfully undertook several high risk, high impact research topics within the contract charter. The continuation of our work on GaAs resulted in the first direct quantitative determination of the diffusivity of hydrogen in any compound semiconductor. Specifically, the diffusivity of positively charged hydrogen in GaAs was determined with capacitance transient techniques, developed at Xerox PARC, and yielded an activation energy for H^+ diffusion of ~ 0.66 eV. In a separate study, depth profiles of diffused hydrogen in n-type GaAs:Si clearly demonstrated a "plateau" at the donor concentration, that is, after hydrogenation the hydrogen (deuterium) concentration nearly equals the donor concentration near the exposed surface. An analysis of the depth profiles yielded an independent determination of the above-quoted thermal dissociation rate for the Si-H complex in GaAs and a lower limit of ~ 0.45 eV for the binding of Si^+ and H^- into Si-H. A new study conducted during the second year focussed on the III-V nitrides, which are of considerable interest due to their optical and electrical properties which are well suited for UV/blue/green light emitters and detectors and for high temperature/high power electronics. Deliberate hydrogenation of MBE-grown, p-type, Mg-doped GaN produced acceptor passivation for hydrogenation temperatures above $500^\circ C$ and introduced a new PL line at 3.35eV. Finally, local vibrational mode spectroscopy in nitrogen-doped ZnSe was used to identify the N-H complex with C_{3v} symmetry: at room temperature the N-H stretching mode appears at 3194 cm^{-1} , and a line at 783 cm^{-1} is tentatively assigned to a N-H wagging mode.

During the final year of the program, work was brought to fruition on a number of topics. Vibrational mode spectroscopy on MBE-grown, Mg-doped GaN films revealed four local vibrational modes in epilayers which as-grown contained high hydrogen concentrations. The modes, studied by Raman and IR absorption spectroscopy, appear to form two pairs. Based on the observed selection rules, one pair, with room-temperature frequencies of 2168 and 2219 cm^{-1} , was tentatively assigned to inequivalent Mg-H complexes in the c plane and parallel to the c axis, respectively; another possibility is a hydrogen-decorated nitrogen vacancy. The origin of the second pair of modes at 2151 and 2185 cm^{-1} , which are IR inactive, was speculatively linked to the presence of diatomic molecules such as N_2 or H_2 , also oriented in two nonequivalent lattice configurations. Newly initiated research on III-V nitrides emphasized experimental and theoretical studies of impurities and native defects in GaN. Computational studies were conducted on the electronic structure, atomic geometry, and formation energies of native defects in GaN; the formation energies for several important donor impurities (C, O, Si) were also determined. One startling conclusion from these studies is that, contrary to a wide-spread notion, the nitrogen vacancy cannot be the source of the high n -type conductivity generally found in undoped as-grown GaN.

Deep level defects in n -type GaN were investigated first with conventional deep level transient spectroscopy (DLTS) and then with photoemission capacitance transient spectroscopy (O-DLTS). In n -type material grown by MOCVD, DLTS revealed two electronic defects with activation energies for electron emission of 0.18 and 0.49 eV. Important future issues will be the determination of the prevalence of these two newly detected deep levels defects in GaN and identification of their chemical nature.

Conventional DLTS is actually of limited use in wide bandgap semiconductors because it utilizes thermal energy for charge emission which restricts the accessible

range of bandgap energies to within ~ 0.9 eV of either band edge (*versus* a 3.4 eV bandgap for GaN at 300 K), for typical trap parameters and measurement conditions. To access deep levels throughout the bandgap, we have demonstrated O-DLTS on a wide-bandgap nitrides and detected four deep levels in n-type GaN with optical threshold energies for electron photoemission to the conduction band of approximately 0.87 eV, 0.97 eV, 1.25 eV, and 1.45 eV. It was suggested that these photo-detected deep levels may participate in the 2.2 eV defect luminescence transitions (i.e., the yellow band), which were also demonstrated in our material. Photoemission capacitance transient spectroscopy will undoubtedly prove to be an important technique for defect characterization and identification in wide-bandgap nitrides.

Two studies were completed on II-VI semiconductors. From correlated SIMS and Hall measurements of nitrogen incorporation in p-type ZnSe and ZnTe, doped with a nitrogen plasma source during MBE, it was suggested that, at least for the growth conditions employed in the study, the nitrogen acceptor solubility, rather than a compensation process, is the controlling factor in determining the acceptor concentration, which is approximately one order of magnitude greater in ZnTe than in ZnSe, despite similar growth conditions. Finally, a study was conducted on hydrogenation effects during the growth of p-type, nitrogen-doped ZnSe *versus* n-type, chlorine-doped ZnSe by gas-source MBE, which typically utilizes both a H_2 carrier gas and a hydride source for Se. The hydrogenation effect was found to be significantly enhanced when nitrogen was used as a dopant and typically resulted in highly resistive films. In contrast, Cl-doped ZnSe films showed a hydrogen concentration near or below the background levels independent of the Cl concentration.

The research program produced 35 publications (published or submitted) in technical journals and conference proceedings and 38 oral presentations (20 of which were invited) at meetings, conferences, and seminars.

LIST OF FIGURES

	page
Fig. 1. Local vibrational modes in MBE-grown, Mg-doped GaN. The Raman spectra (a) and (b) and the IR spectrum (c) were obtained from different samples. Two pairs of LVM's are detected, as indicated by the dashed and dotted lines. Only the pair at 2168 and 2219 cm^{-1} is IR active.	3
Fig. 2. Defect formation energies as a function of the Fermi level for native defects in GaN under Ga-rich conditions. The Fermi energy $E_F = 0$ corresponds to the top of the valence band.	5
Fig. 3. DLTS spectrum for a Schottky diode on n-type GaN. The spectrometer emission rate window $e_0 = 231 \text{ s}^{-1}$ corresponds to sampling delay times of 2 and 8 ms.	7
Fig. 4. Schematic diagram of the apparatus for photoemission capacitance transient spectroscopy on wide-bandgap semiconductors.	9
Fig. 5. IR absorption spectra of deuterated and hydrogenated GaP:Zn. The vibrational modes are associated with H-P (D-P) complexes adjacent to the Zn acceptors.	10
Fig. 6. Model for H passivation of the Zn acceptor with the H atom attached to a P atom in a bond-centered orientation in GaP:Zn.	11

- Fig. 7. Depth profiles of hydrogen and nitrogen in a ZnSe epitaxial structure. The layer contains regions that are uniformly doped with nitrogen separated by zones of undoped material, as schematically indicated at the bottom of the figure. 13
- Fig. 8. Depth profiles of nitrogen in heavily doped ZnSe and ZnTe epilayers grown under similar conditions. 15

I. Introduction

This report describes research that was conducted for the U.S. Air Force Office of Scientific Research under Contract No. F49620-91-C-0082 during the period from 5 September 1991 to 4 September 1994, with emphasis on the work completed during the final year. An overview of the entire program is presented in the Executive Summary, and the performance statistics for the entire program are summarized in appendices at the end of this report.

Experimental and theoretical studies were conducted to identify basic mechanisms and provide quantitative information on the properties of hydrogen in selected (technologically-important) III-V and II-VI semiconductors and their alloys. The information pertains to the migration, chemical kinetics, and microscopic structure of hydrogen and its complexes in such semiconductors. During the final year of the contract, in addition to completing several studies on the properties of hydrogen in compound semiconductors, we also completed computational studies on native defects and selected impurities in GaN, experiments on the characterization of electronic defects in GaN by deep level transient spectroscopy and photoemission capacitance transient spectroscopy, and observations on the limits to p-type doping in ZnSe.

Performance statistics for the entire program are summarized in appendices at the end of the report. **Appendix I** lists the professional personnel who directly contributed to the contract or who participated through collaborative arrangements. In **Appendix II** a cumulative chronological list is presented of technical publications (published or submitted during the contract period) in scientific journals and conference proceedings on work performed under the contract. Finally, **Appendix III** lists oral presentations (invited and contributed) at meetings, conferences, and seminars on work conducted under the contract.

II. Local Vibrational Modes in Mg-doped GaN

Wide-bandgap III-V semiconductors are receiving considerable attention due to their possible applications in ultraviolet, blue, and green light emission devices and high-temperature/high-power electronics. A major obstacle to the realization of such devices is an apparent difficulty in obtaining p-type doping in these materials when using growth techniques such as metalorganic chemical vapor deposition (MOCVD). One way that this limitation has been overcome is by the successful growth of films with molecular beam epitaxy (MBE). The absence of hydrogen from the gas phase during MBE growth has led to the assumption that the formation of acceptor-hydrogen complexes is the reason for the low doping efficiency in MOCVD-grown material.

A definite proof for the existence of an acceptor-hydrogen complex can be obtained by identification of its local vibrational modes (LVM) with infrared (IR) or Raman spectroscopy. By analyzing the polarization dependence of vibrational modes in IR and Raman experiments, information on the symmetry of the complex can be obtained. Calculations determining the total energy of different atomic configurations that are compatible with the observed symmetry or with measurements of the vibrational modes under uniaxial stress can then identify the microscopic structure of the complex.

As a first step in the above approach to defect identification, a study was conducted with vibrational mode spectroscopy on Mg-doped GaN epilayers which contained high concentrations of hydrogen as-grown [1,2]. Wurtzite GaN epilayers were grown on (0001) c-plane sapphire substrates by electron cyclotron resonance (ECR) microwave plasma assisted MBE [3,4]. Gallium and magnesium were evaporated from conventional Knudsen cells, and activated nitrogen was provided by the ECR source. Prior to the growth of the GaN epilayer, the substrates were exposed to the N-plasma for 30 min to convert the surface of the sapphire substrates

to AlN. A GaN buffer layer was then grown at 500°C followed by the high-temperature growth of the actual film at 800°C. The two-temperature growth procedure promotes lateral growth and, thus, layer-by-layer growth. Depth profiles from secondary ion mass spectrometry (SIMS) revealed Mg concentrations of $\sim 10^{20}$ cm^{-3} , and room-temperature Hall measurements yielded hole concentrations of up to 10^{19} cm^{-3} in some samples, which corresponds to a doping efficiency of $\sim 10\%$. However, the specific samples studied here also possessed H-concentrations above 10^{19} cm^{-3} as determined with SIMS. The exact origin of this contamination is unknown, but appears to correlate with the microwave power of the ECR source and linked to the Mg doping.

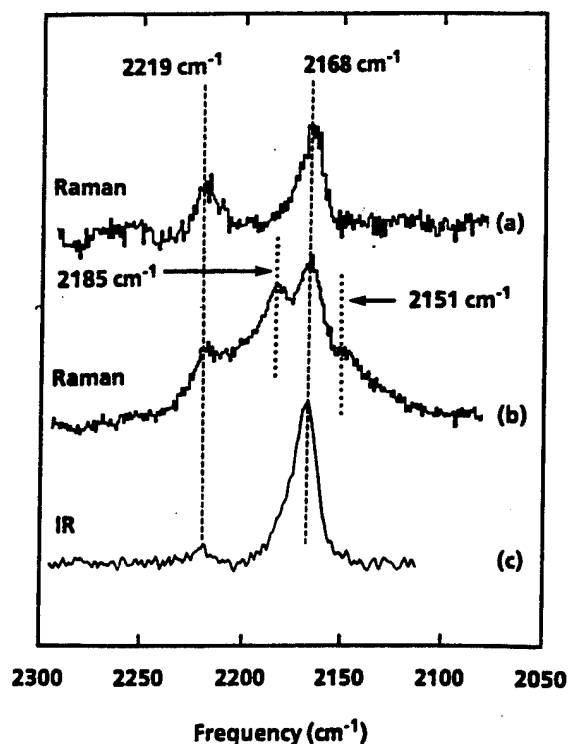

Fig. 1. Local vibrational modes in MBE-grown, Mg-doped GaN. The Raman spectra (a) and (b) and the IR spectrum (c) were obtained from different samples. Two pairs of LVM's are detected, as indicated by dashed and dotted lines. Only the pair at 2168 and 2219 cm^{-1} is IR active.

The results of the room-temperature Raman and infrared absorption measurements on a variety of Mg-doped GaN samples are summarized in Fig. 1. Four Raman active vibrational modes were detected, which appear to comprise two pairs. One sample shows only the first pair at 2168 and 2219 cm^{-1} (Fig. 1(a)). In most samples studied, however, a second pair at 2151 and 2185 is observed as shown in the Raman spectra of Fig. 1(b), the lower frequency peak being considerably broader than the other peaks observed here. Within a pair, the relative intensities of the peaks remain constant at 1 to 2 for both pairs, while the intensities of the two pairs with respect to each other vary considerably as exhibited by the two Raman spectra shown. Both pairs showed the same polarization dependence.

Both undoped and hydrogenated Si-doped ($4 \times 10^{20} \text{ cm}^{-3}$) control samples were investigated for similar vibrational modes both in this frequency region and near 3000 cm^{-1} . No Raman signal of a local vibrational mode was found in these samples.

In the IR absorption measurements on our MBE-grown, Mg-doped GaN films only the first pair of modes (at 2168 and 2219 cm^{-1}) was observed, with the high frequency mode at 2219 cm^{-1} barely detectable in the specific transmission geometry that was used. In fact, the IR spectrum shown in Fig. 1(c) was obtained on a sample possessing a particularly strong Raman signal at 2185 cm^{-1} , which is a constituent of the second pair. The typical line width of the 2168 cm^{-1} mode observed with both techniques is 15 cm^{-1} . This inhomogeneous broadening might be due to residual strain or the high concentration of vibrational centers.

The origin and microscopic structure of the defects responsible for the above pairs of LVM's have yet to be identified. Since the modes seem to correlate with the presence of Mg and because of the high hydrogen concentrations found in the specimens, we speculate that the pair of IR active modes (2168 and 2219 cm^{-1}) may arise from inequivalent Mg-H complexes, with the inequivalence due to bond axes in

the c-plane or parallel to the c-plane. The origin of the pair of IR inactive modes (at 2151 and 2185 cm^{-1}) is speculatively linked to the presence of diatomic molecules such as N_2 or H_2 in the GaN. Future studies should examine deuterated specimens of Mg-doped GaN to confirm the participation of hydrogen in the complex through detection of isotopic frequency shifts. In addition, total energy calculations will be invaluable to identify the microscopic configuration of the Mg-H complex in GaN.

III. Computational Studies of Native Defects and Dopants in GaN

Computational techniques were used to study the electronic structure, atomic geometry, and formation energies of native defects in GaN [5-7]. In addition, formation energies for several important donor impurities (C, O, Si) were also determined. The approach utilized first-principles calculations based on density-functional theory in the local-density approximation.

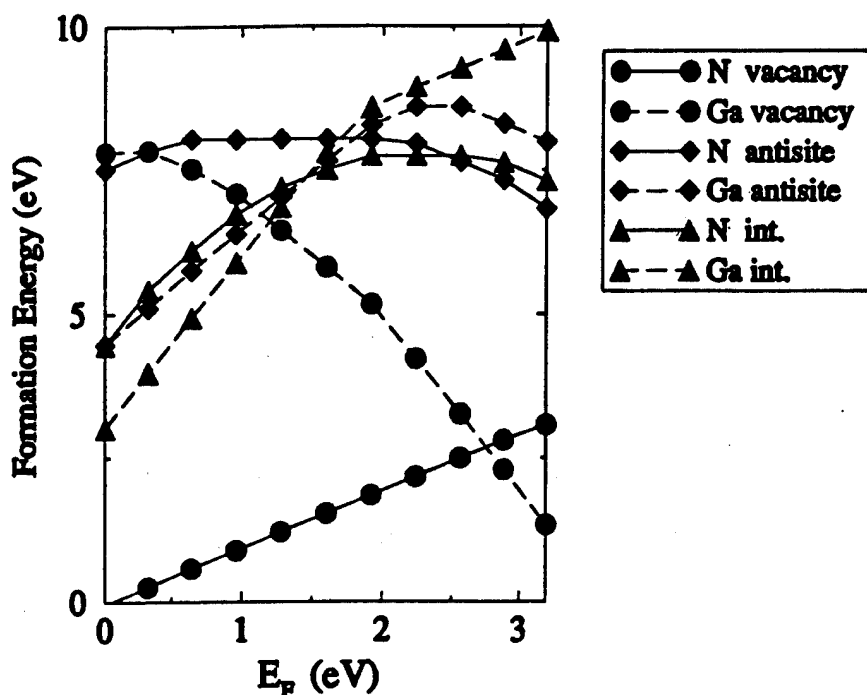

Fig. 2. Defect formation energies as a function of the Fermi level for all native defects in GaN under Ga-rich conditions. The Fermi energy $E_F = 0$ corresponds to the top of the valence band.

Figure 2 summarizes the formation energies for native defects in GaN. The most striking features are the low formation energies for the gallium and nitrogen vacancies. Under n-type conditions the gallium vacancy (a triple acceptor) dominates, while under p-type conditions the nitrogen vacancy (a single donor) dominates. All other native defects are much higher in energy and should play no role under thermodynamic equilibrium.

A nearly vanishing formation energy for the nitrogen vacancy under p-type conditions seems to preclude the possibility of producing p-type GaN. However, these energies are given for the Ga-rich case, which supports the formation of N vacancies. Under N-rich conditions the formation energy of the N-vacancy increases to about 1 eV, making p-type doping possible.

Under n-type conditions the defect with the lowest formation energy is the Ga vacancy. Since the Ga vacancy acts as an acceptor, it will partly compensate the source of the n-type conductivity. The nitrogen vacancy, with a formation energy of more than 3 eV, is too high in energy to be formed in appreciable concentrations. Thus, contrary to a wide-spread notion, the nitrogen vacancy (or any of the native defects) cannot be the source of the high n-type conductivity in undoped as-grown GaN.

Unintentional doping by impurities is another possible explanation for the high n-type conductivity in as-grown GaN. Carbon, oxygen, and silicon are likely candidates in both MOCVD and MBE grown GaN. Consequently, in this study formation energies were calculated for carbon and silicon on a Ga site and oxygen on a nitrogen site, where they should exhibit donor-like character. The formation energies for Ga- and N-rich conditions are as follows: for Si_{Ga} the energies are 1.2 eV (Ga-rich) and 2.8 eV (N-rich), for O_{N} they are 1.8 eV (Ga-rich) and 2.8 eV (N-rich), and for C_{Ga} they are 6.5 eV (Ga-rich) and 5.4 eV (N-rich). Thus, silicon (under Ga-rich conditions) and oxygen (under N-rich conditions) are the donor impurities with the

lowest formation energies. Experimentally, both of these impurities are likely to be present during growth, either as contaminants in source gases or in MBE from the walls (usually quartz) of the plasma source.

IV. Deep Level Transient Spectroscopy on n-type GaN

Deep level defects were investigated in n-type GaN with deep level transient spectroscopy (DLTS) [8]. The GaN was epitaxially grown on sapphire by MOCVD and doped with silicon for n-type conductivity. The GaN epilayer actually consisted of two layers with different n-type doping concentrations. The first layer was heavily doped for n⁺-type conductivity. A semiconducting layer with a donor concentration of $1.8 \times 10^{17} \text{ cm}^{-3}$ was grown directly over the n⁺ layer. This structure permitted the fabrication of Schottky diodes with Ohmic back contacts and low series resistance: the Schottky metal was deposited through a shadow mask directly onto the semiconducting layer and the Ohmic contact was evaporated onto laterally exposed n⁺ material.

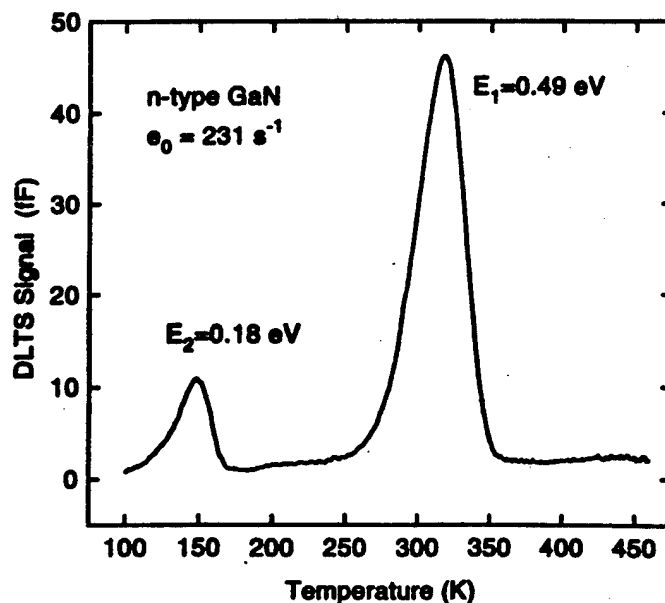

Fig. 3. DLTS spectrum for a Schottky diode on n-type GaN. The spectrometer emission rate window $e_0 = 231 \text{ s}^{-1}$ corresponds to sampling delay times of 2 and 8 ms.

A representative DLTS spectrum is shown in Fig. 3. The spectrum reveals two DLTS peaks which arise from electron emission from two electronic deep levels. With each peak is listed the thermal activation energy for electron emission. The amplitude of each peak relates to the concentration of the corresponding defect: the high and low temperature peaks arise from trap concentrations of $6.3 \times 10^{14} \text{ cm}^{-3}$ and $7 \times 10^{13} \text{ cm}^{-3}$, respectively. Important future issues will be the determination of the prevalence of the two newly detected deep level defects in GaN and identification of their chemical nature.

V. Photoemission Capacitance Transient Spectroscopy on n-type GaN

While DLTS is the most sensitive spectroscopy yet devised for the characterization of electronic defects in semiconductors, it is actually of limited use in wide bandgap semiconductors because it utilizes thermal energy for charge emission which restricts the accessible range of bandgap energies to within $\sim 0.9 \text{ eV}$ of either band edge (versus a 3.4 eV bandgap for GaN at 300 K), for typical trap parameters and measurement conditions. To access deep levels throughout the bandgap, we have now demonstrated photoemission DLTS on wide-bandgap nitrides [9].

A schematic diagram of the apparatus is shown in Fig. 4. A Schottky diode is placed in a continuous-flow cryostat (C) and maintained at 150 K ; the low temperature is used to freeze out thermal emission processes. The diode is backside illuminated through the sapphire substrate with monochromatic light from a quartz tungsten-halogen lamp (LS) and a double-grating monochromator (Mc). The relative intensity of the incident light is continuously monitored by using a beam splitter (BS), light chopper (Ch), and a pyroelectric detector (D), with standard phase-sensitive detection. Sub-bandgap photons ($h\nu < E_G$) are used to emit charge from deep levels in the depletion layer of a Schottky diode at the low temperature, with the transitions detected as a time-varying capacitance. The photoemission decay

time relates to the optical cross section(s), and the steady-state change in the photocapacitance is proportional to the energy-integrated density of optically active defects.

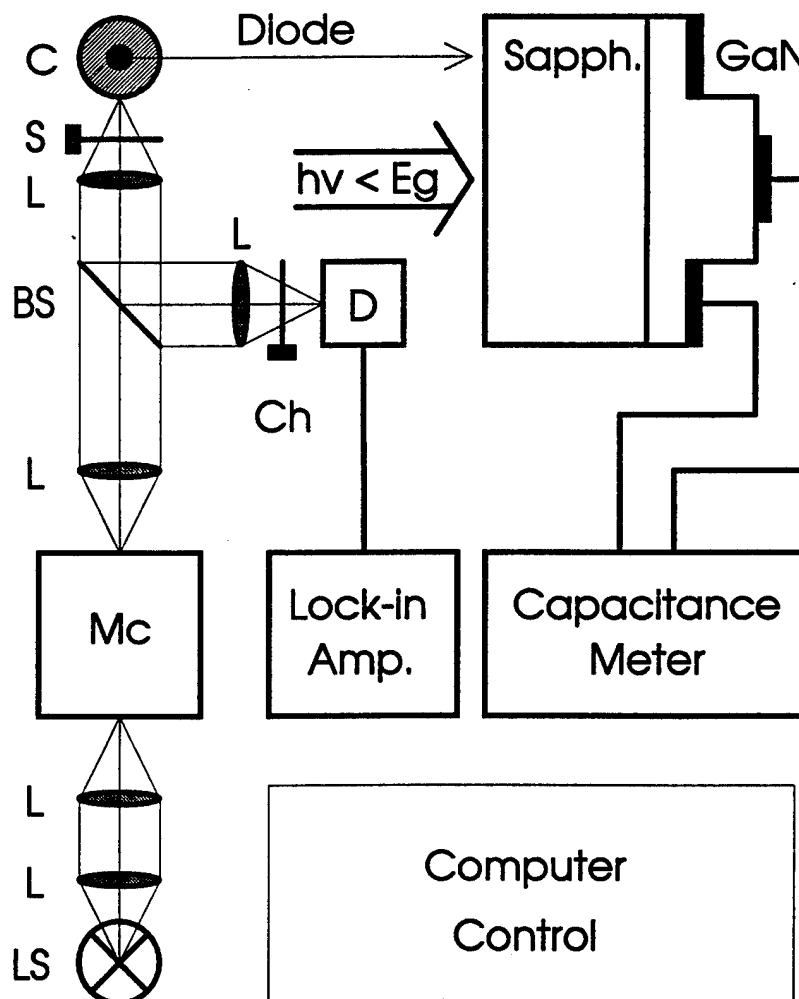

Fig. 4. Schematic diagram of the apparatus for photoemission capacitance transient spectroscopy on wide-bandgap semiconductors.

Under measurement conditions favoring electron photoemission to the conduction band, four deep levels were detected in n-type GaN at optical threshold energies of approximately 0.87 eV, 0.97 eV, 1.25 eV, and 1.45 eV. It was suggested that these photo-detected deep levels may participate in the 2.2 eV defect luminescence transitions (i.e., the yellow band), which were also demonstrated in our material. The same apparatus, with minor modifications, enabled an internal-

photoemission determination of the Au-GaN barrier height for electrons of ~ 1.05 eV (at 150 K), after correction for electric-field induced barrier lowering (the Schottky effect). Photoemission capacitance transient spectroscopy will undoubtedly prove to be an important technique for defect characterization and identification in wide-bandgap nitrides. For example, it can be combined with photoluminescence to locate the individual levels responsible for defect luminescence or with TEM for possible correlations of deep levels with dislocations.

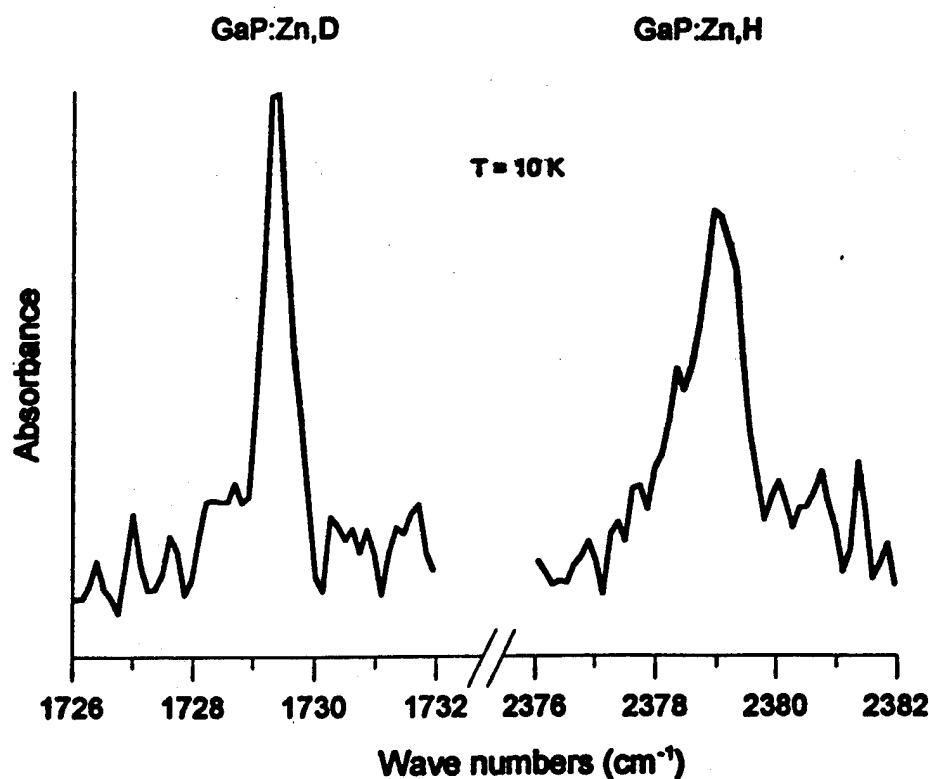

Fig. 5. IR absorption spectra of deuterated and hydrogenated GaP:Zn. The vibrational modes are associated with H-P (D-P) complexes adjacent to the Zn acceptors.

VI. Local Vibrational Modes in Hydrogenated GaP:Zn

Infrared absorption spectroscopy was performed on hydrogenated specimens of Zn-doped GaP for the purpose of identifying the local vibrational mode(s) for the

Zn-H complex [10]. Prior to this study, there had been no report of local modes in GaP corresponding to a complex involving a group-II acceptor and hydrogen. Bulk specimens of GaP, Zn doped by high-temperature diffusion, were hydrogenated in a remote plasma system. Spectra for hydrogenated versus deuterated samples are shown in Fig. 5. The absorption peaks appear (at 10 K) at 2379.0 and 1729.4 cm^{-1} for the hydrogenated and deuterated material, respectively, which yields an isotopic frequency shift of 1.3756. The isotopic shift is very close to that for the Zn-H complex in InP (1.3744), which may suggest that they have the same structure. The modes are therefore assigned to H-P and D-P bond-stretching modes of complexes adjacent to the zinc acceptors, as illustrated in Fig. 6.

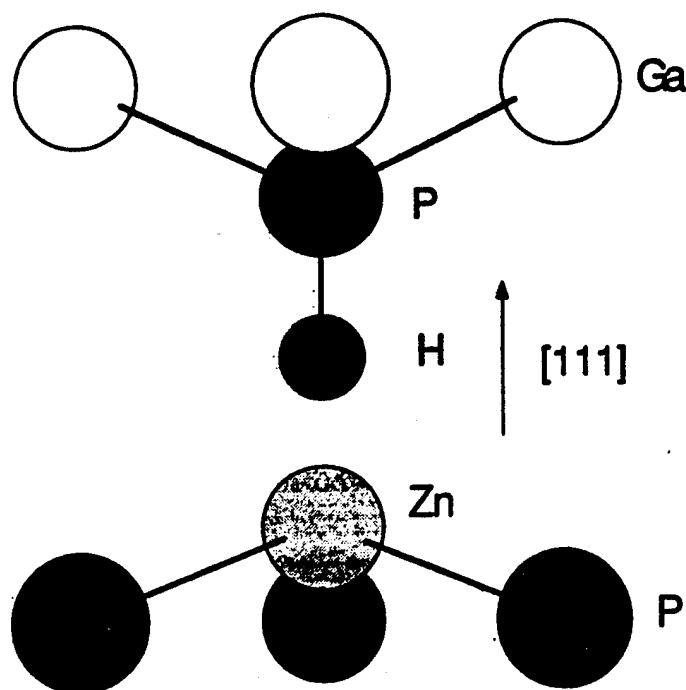

Fig. 6. Model for H passivation of the Zn acceptor with the H atom attached to a P atom in a bond-centered orientation in GaP:Zn.

VII. Hydrogen Passivation of Dopants in ZnSe

With the success of conventional MBE in producing blue-green laser diodes from II-VI semiconductors, there has been interest in extending this capability to gas source epitaxial techniques (e.g., GS and MOVPE), since they offer the possibility of significant improvement in alloy composition control through the use of mass flow controllers. However, progress in p-type doping of ZnSe by MOVPE has been hampered by unintentional hydrogen incorporation, which is believed to cause passivation of the nitrogen acceptor atoms and which originates from the source species and the large amount of molecular hydrogen that is present in the growth environment.

The present study investigated the incorporation behavior of hydrogen in p-type ZnSe:N grown by GSMBE and compared the findings with those for chlorine-doped (n-type) ZnSe [11,12]. The sources for the host constituents were elemental Zn and gaseous H_2Se . The donor dopants were obtained from an effusion source of $ZnCl_2$, and the acceptor dopants were obtained from a nitrogen plasma source.

The hydrogenation effect was found to be significantly enhanced when nitrogen was used as a dopant and typically resulted in highly resistive films. The effect is illustrated in Fig. 7 with depth profiles from SIMS of N and H in a ZnSe epilayer. The hydrogen closely tracks the nitrogen throughout the film. This suggests that N-H bonds are formed, which accounts for the observed high resistivity. This is in agreement with previous work which established the presence of N-H bonds in MOCVD-grown ZnSe [13]. In contrast, Cl-doped ZnSe films showed a hydrogen concentration near or below the SIMS background level independent of the Cl concentration.

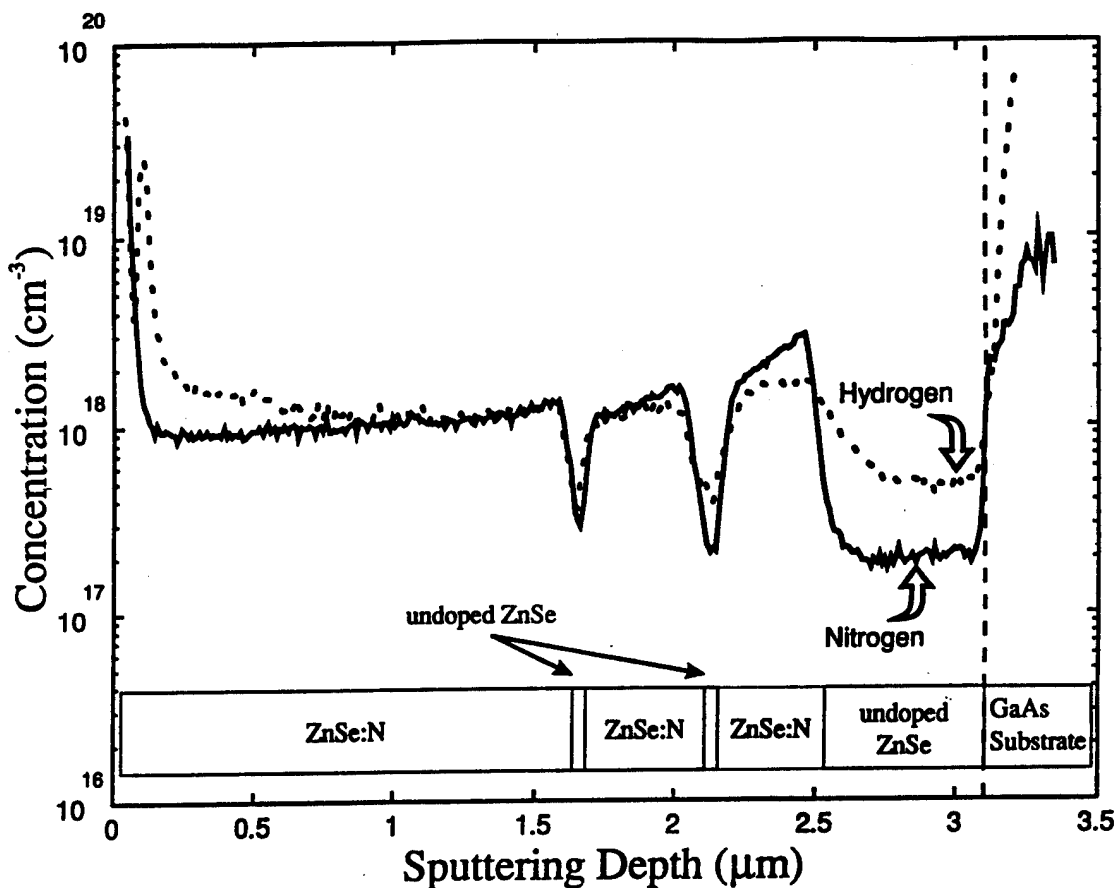

Fig. 7. Depth profiles of hydrogen and nitrogen in a ZnSe epitaxial structure. The layer contains regions that are uniformly doped with nitrogen separated by zones of undoped material, as schematically indicated at the bottom of the figure.

ZnSe was also grown by conventional MBE with intentionally introduced H₂ in order to clarify the source of the hydrogen. Significant hydrogen incorporation was observed in MBE-grown ZnSe:N layers only when hydrogen gas was introduced. Injection of hydrogen in excess of the amount generated during typical GSMBE experiments was found to give rise to an unambiguous increase in the hydrogen concentration, but with a H to N ratio less than that measured in GSMBE films.

Several conclusions can be drawn from this study regarding the effects of hydrogen in ZnSe:N films: (1) the presence of H₂ in the growth environment, either intentionally injected or derived from the thermal decomposition of H₂Se, results in

unambiguous dopant-enhanced hydrogenation when nitrogen is used as a dopant, (2) in GSMBE, sub-hydride species due to incomplete cracking of H_2Se further contribute to the observed hydrogenation, (3) diffusion of hydrogen is small as evidenced by a relatively sharp transition in the H concentration from a hydrogenated layer to an unhydrogenated layer grown by conventional MBE, and (4) the absence of hydrogen above background level in a conventional MBE layer without H_2 indicates that any "long-term memory effect" of hydrogen in an MBE reactor can be neglected.

VIII. Observations on the Limits to p-type Doping in ZnSe

At present the most successful p-type dopant and doping procedure for ZnSe appears to be an active nitrogen species (e.g., monatomic nitrogen) produced by a plasma source during MBE growth. This approach has produced free-hole concentrations of $2 - 3 \times 10^{17} \text{ cm}^{-3}$ (at 293 K). In contrast, when ZnTe is grown with the same nitrogen plasma conditions, the free-hole concentration exceeds $1 \times 10^{19} \text{ cm}^{-3}$. Two competing explanations have been proposed to explain the striking difference in the ability to achieve high p-type doping levels between ZnSe and ZnTe: (1) "self-compensation" by either native defects or dopant/lattice relaxation and (2) the acceptor solubility limitation of the dopants.

In the present study SIMS measurements of nitrogen incorporation in p-type ZnSe and ZnTe, doped using a nitrogen plasma source during MBE, were correlated with transport data from variable-temperature Hall measurements [14]. Figure 8 presents depth profiles of nitrogen in heavily doped ZnSe and ZnTe epilayers grown at 245°C . The nitrogen density in the ZnSe was $1.2 \times 10^{18} \text{ cm}^{-3}$, which is close to the acceptor concentration of $9.5 \times 10^{17} \text{ cm}^{-3}$ that was obtained from the Hall measurements. This suggests that at the doping levels and particular growth conditions used in this study close to 100% of the nitrogen atoms are substitutional at Se lattice sites and act as active acceptors.

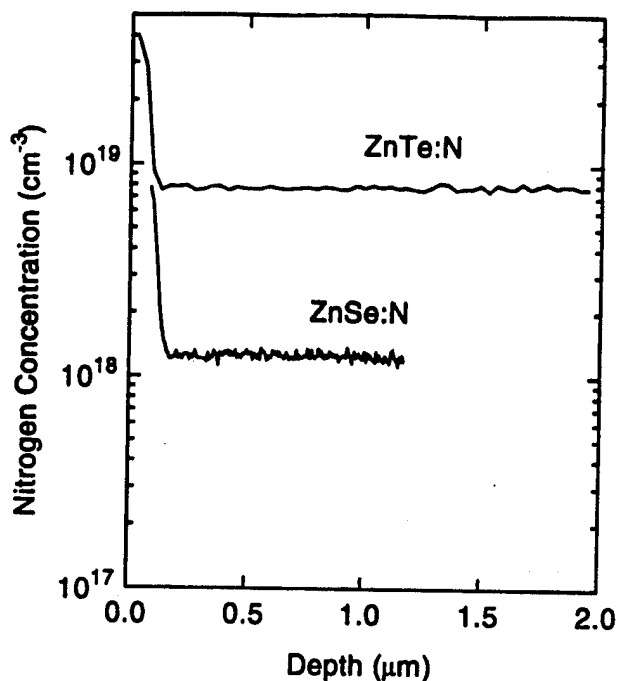

Fig. 8. Depth profiles of nitrogen in heavily doped ZnSe and ZnTe epilayers grown under similar conditions.

In the ZnTe specimen in Fig. 8 the nitrogen density was $8 \times 10^{18} \text{ cm}^{-3}$, even though the growth conditions were nominally the same as for the ZnSe sample. The room-temperature free-hole concentration in the ZnTe sample was $7 \times 10^{18} \text{ cm}^{-3}$, which provides a lower limit of the nitrogen acceptor concentration. Thus, it appears that almost 100% of the nitrogen atoms are incorporated at the Te sites and serve as acceptors.

The above results suggest that, at least for the growth conditions employed in this study, the nitrogen acceptor solubility is the controlling factor in determining the acceptor concentration, which is approximately one order of magnitude greater in ZnTe than in ZnSe, despite similar growth conditions.

REFERENCES

1. M. S. Brandt, J. W. Ager III, W. G. Götz, N. M. Johnson, J. S. Harris Jr., R. J. Molnar, and T. D. Moustakas, *Phys. Rev. B* 49, 14758 (15 May 1994-II).
2. M. S. Brandt, N. M. Johnson, R. J. Molnar, R. Singh, and T. D. Moustakas, "Hydrogenation of Gallium Nitride," (Materials Research Society, Pittsburgh, PA, 1994), eds. M. O. Manasreh, H. J. von Bardeleben, G. S. Pomrenke, M. Lannoo, and D. N. Talwar, *Materials Research Society Symposium Proceedings*, Vol. 325, p. 341.
3. T. D. Moustakas and R. J. Molnar, in *Semiconductor Heterostructure for Photonic and Electronic Applications*, eds. C. W. Tu, D. C. Houghton, and R. T. Tung, *Materials Research Society Symp. Proc.* 281, (Materials Research Society, Pittsburgh, 1993), p. 753.
4. T. D. Moustakas, T. I. Lei, and R. J. Molnar, *Physica B* 185, 36 (1993).
5. J. Neugebauer and C. G. Van de Walle, *Phys. Rev. B* 50, 8067 (15 September 1994).
6. J. Neugebauer and C. G. Van de Walle, *Proceedings of the 22nd International Conference on the Physics of Semiconductors* (World Scientific Publishing Co Pte Ltd., Singapore, 1995), Vancouver, B.C., August 15 - 19, 1994, in press.
7. J. Neugebauer and C. G. Van de Walle, *Diamond, SiC and Nitride Wide Bandgap Semiconductors* (Materials Research Society, Pittsburgh, Pennsylvania, 1995), eds. C. H. Carter Jr., G. Gildenblat, S. Nakamura, and R. J. Nemanich, *Materials Research Society Symposia Proceedings* 339, in press.
8. W. Götz, N. M. Johnson, H. Amano, and I. Akasaki, *Appl. Phys. Lett.* 65, 463 (25 July 1994).

9. W. K. Götz, N. M. Johnson, R. A. Street, H. Amano, and I. Akasaki, *Appl. Phys. Lett.* 66, 1340 (1995).
10. M. D. McCluskey, E. E. Haller, J. Walker, and N. M. Johnson, *Appl. Phys. Lett.* 65, 2191 (24 October 1994).
11. P. A. Fisher, E. Ho, J. L. House, G. S. Petrich, L. A. Kolodziejski, M. S. Brandt, and N. M. Johnson, *Compound Semiconductor Epitaxy* (Materials Research Society, Pittsburgh, PA, 1994), eds. C. W. Tu, L. A. Kolodziejski, and V. R. McCrary, *Materials Research Society Symposium Proceedings* 340, pp. 451 - 456.
12. E. Ho, P. A. Fischer, J. L. House, G. S. Petrich, L. A. Kolodziejski, J. Walker, and N. M. Johnson, *Appl. Phys. Lett.*, in press.
13. J. A. Wolk, J. W. Ager III, K. J. Duxstad, E. E. Haller, N. R. Taskar, D. R. Dorman, and D. J. Olego, *Appl. Phys. Lett.* 63, 2756 (1993).
14. Y. P. Fan, J. Han, L. He, R. L. Gunshor, M. S. Brandt, J. Walker, N. M. Johnson, and A. V. Nurmikko, *Appl. Phys. Lett.* 65, 1001 (22 August 1994).

APPENDIX I.
LIST OF PROFESSIONAL PERSONNEL

Professional personnel who were directly involved and contributed to the program are listed below by principal affiliation:

Xerox PARC

N. M. Johnson	Principal Scientist and Principal Investigator
C. G. Van de Walle	Member Research Staff
C. Herring	Consultant and Professor Emeritus, Department of Applied Physics, Stanford University
D. Bour	Member Research Staff
R. A. Street	Research Fellow
G. Roos	Postdoctoral Scientist
M. Brandt	Postdoctoral Scientist
W. Götz	Postdoctoral Scientist
J. Neugebauer	Postdoctoral Scientist
J. Walker	Member Research Staff

UC Berkeley and Lawrence Berkeley Laboratory

E. E. Haller	Professor, Department of Materials Science and Mineral Engineering, University of California, Berkeley, and the Lawrence Berkeley Laboratory
G. Hofmann	Postdoctoral Scientist, Lawrence Berkeley Laboratory
J. A. Wolk	Postdoctoral Scientist, Lawrence Berkeley Laboratory
M. D. McCluskey	Graduate Student, Lawrence Berkeley Laboratory

Several of the studies were enabled by collaborations with colleagues and students not directly involved with the AFOSR contract. These individuals included

J. W. Ager III	Staff Scientist, Lawrence Berkeley Laboratory
I. Akasaki	Professor Emeritus, Department of Electrical and Electronic Engineering, Meijo University, Nagoya, Japan.
H. Amano	Professor, Department of Electrical and Electronic Engineering, Meijo University, Nagoya, Japan.
P. E. Blöchl	IBM Research Division, Forschungslaboratorium, Zürich, Switzerland
R. C. De Mattei	Graduate Student, Department of Materials Science and Engineering, Stanford University
D. R. Dorman	Technical Staff, Philips Laboratories, Briarcliff Manor, NY
K. J. Duxstad	Graduate Student, Department of Materials Science and Mineral Engineering, University of California, Berkeley, and the Lawrence Berkeley Laboratory
Y. P. Fan	Graduate student, School of Electrical Engineering, Purdue University, West Lafayette, Indiana
R. S. Feigelson	Professor, Department of Materials Science and Engineering, Stanford University
P. A. Fischer	Graduate student, Department of Electrical Engineering and Computer Science, MIT
R. L. Gunshor	Professor, School of Electrical Engineering, Purdue University, West Lafayette, Indiana

- N. M. Haegel Professor, Department of Materials Science and Engineering, University of California, Los Angeles
- J. Han Graduate student, School of Electrical Engineering, Purdue University, West Lafayette, Indiana
- J. S. Harris, Jr. Professor, Solid State Electronics Laboratory, Department of Electrical Engineering, Stanford University
- L. He Graduate student, School of Electrical Engineering, Purdue University, West Lafayette, Indiana
- E. Ho Graduate student, Department of Electrical Engineering and Computer Science, MIT
- J. L. House Graduate student, Department of Electrical Engineering and Computer Science, MIT
- L. Kolodziejcki Professor, Department of Electrical Engineering and Computer Science, MIT
- S. M. Lord Graduate Student, Solid State Electronics Laboratory, Department of Electrical Engineering, Stanford University
- J. Madok Graduate Student, Department of Materials Science and Engineering, University of California, Los Angeles
- R. J. Molnar Graduate Student, Department of Electrical, Computer, and Systems Engineering, Boston University, Boston, MA
- T. D. Moustakas Professor, Department of Electrical, Computer, and Systems Engineering, Boston University, Boston, MA

- A. V. Nurmikko Professor, Division of Engineering, Brown University,
Providence, Rhode Island
- D. J. Olego Technical Staff, Philips Laboratories, Briarcliff Manor, NY
- Y. C. Pao Graduate Student, Solid State Electronics Laboratory,
Department of Electrical Engineering, Stanford
University
- L. Pavesi Professor, Università degli Studi di Trento, Dipartimento
di Fisica, Trento, Italy
- G. S. Petrich Graduate student, Department of Electrical Engineering
and Computer Science, MIT
- B. Pezeshki Graduate Student, Solid State Electronics Laboratory,
Department of Electrical Engineering, Stanford
University
- C. Pong Graduate Student, Department of Materials Science and
Engineering, Stanford University
- R. Singh Graduate Student, Department of Electrical, Computer,
and Systems Engineering, Boston University, Boston, MA
- N. R. Taskar Technical Staff, Philips Laboratories, Briarcliff Manor, NY

APPENDIX II.

LIST OF PUBLICATIONS

(published or submitted during contract period)

1. G. Roos, N. M. Johnson, C. Herring, and J. S. Harris, "Thermal Dissociation Energy of the Si-H Complex in *n*-type GaAs," *Applied Physics Letters*, Vol. 59, No. 4, pp. 461-463 (22 July 1991).
2. G. Roos, N. M. Johnson, C. Herring, and J. S. Harris, Jr., "Dissociation Kinetics of Hydrogen-neutralized Si Donors and DX Centers in AlGaAs," *Proceedings of the 16th International Conference on Defects in Semiconductors* (Trans Tech Publ, Zurich, 1992), eds. G. Davies, G. G. DeLeo, and M. Stavola, Vol. 83-87, pp. 605-610.
3. S. M. Lord, G. Roos, B. Pezeshki, J. S. Harris, Jr., and N. M. Johnson, "Enhancement of Photoluminescence Intensity in InGaAs/Al_xGa_{1-x}As Quantum Wells by Hydrogenation," *Applied Physics Letters*, Vol. 60, No. 18, pp. 2276-2278 (4 May 1992).
4. G. Roos, N. M. Johnson, Y. C. Pao, J. S. Harris, Jr., and C. Herring, "Hydrogen Passivation of Si and Be Dopants in InAlAs," *Advanced III-V Compound Semiconductor Growth, Processing and Devices* (Materials Research Society, Pittsburgh, PA, 1992), eds. S. J. Pearton, D. K. Sadana, and J. M. Zavada, *Materials Research Society Symposium Proceedings*, Vol. 240, pp. 667-672.
5. N. M. Johnson, "Hydrogen in Compound Semiconductors," *Defect Engineering in Semiconductor Growth, Processing, and Device Technology* (Materials Research Society, Pittsburgh, PA, 1992), eds. S. Ashok, J. Chevallier, K. Sumino, and E. Weber, *Materials Research Society Symposium Proceedings Series*, Vol. 262, pp. 369-382.

6. G. Roos, N. M. Johnson, C. Herring, and J. S. Harris, Jr., "Hydrogen Passivation and Reactivation of DX Centers in Se-doped and Si-doped AlGaAs -- A Comparison," *Defect Engineering in Semiconductor Growth, Processing, and Device Technology* (Materials Research Society, Pittsburgh, PA, 1992), eds. S. Ashok, J. Chevallier, K. Sumino, and E. Weber, Materials Research Society Symposium Proceedings Series, Vol. 262, pp. 419-424.
7. S. M. Lord, G. Roos, B. Pezeshki, J. S. Harris, Jr., and N. M. Johnson, "Hydrogen Passivation of Defects in InGaAs/Al_xGa_{1-x}As Quantum Wells," *Defect Engineering in Semiconductor Growth, Processing, and Device Technology* (Materials Research Society, Pittsburgh, PA, 1992), eds. S. Ashok, J. Chevallier, K. Sumino, and E. Weber, Materials Research Society Symposium Proceedings Series, Vol. 262, pp. 881-886.
8. G. Hofmann, J. Madok, N. M. Haegel, G. Roos, N. M. Johnson, and E. E. Haller, "Interaction of Hydrogen and Deuterium with Copper in GaAs," *Applied Physics Letters*, Vol. 61, No. 24, pp. 2914 - 2916 (14 December 1992).
9. C. Pong, N. M. Johnson, R. A. Street, J. Walker, R. S. Feigelson, and R. C. De Mattei, "Hydrogenation of Wide-band-gap II-VI Semiconductors," *Applied Physics Letters*, Vol. 61, No. 25, pp. 3026 - 3028 (21 December 1992).
10. G. Roos, N. M. Johnson, C. Herring, H. F. Chung, R. L. Thornton, and J. S. Harris, Jr., "Hydrogen Passivation and Reactivation of Se Dopants in AlGaAs," 15th State-of-the-Art Program on Compound Semiconductors (The Electrochemical Society, Pennington, NJ, 1992), eds. A. Katz, N. Buckley, V. Swaminathan, P. Clechef, and O. Ueda, The Electrochemical Society Proceedings Series, Vol. 92-19, pp. 94 - 103.

11. C. G. Van de Walle, "Hydrogen in Crystalline Semiconductors," in Deep Centers in Semiconductors (Academic Press, New York, 1992), ed. S. T. Pantelides, Chap. 12.
12. S. M. Lord, G. Roos, J. S. Harris, Jr., and N. M. Johnson, "Hydrogen Passivation of Nonradiative Defects in InGaAs/Al_xGa_{1-x}As Quantum Wells," *Journal of Applied Physics*, Vol. 73, No. 2, pp. 740-748 (15 January 1993).
13. C. G. Van de Walle and P. E. Blöchl, "First-principles Calculations of Hyperfine Parameters," *Physical Review B*, Vol. 47, No. 8, pp. 4244 - 4255 (15 February 1993-II).
14. C. G. Van de Walle and L. Pavesi, "Spin-polarized Calculations and Hyperfine Parameters for Hydrogen or Muonium in GaAs," *Physical Review B*, Vol. 47, No. 8, pp. 4256 - 4260 (15 February 1993-II).
15. E. E. Haller, "Hydrogen in Compound Semiconductors," in Record of the 12th Symposium on Alloy Semiconductor Physics and Electronics, Izunagaoka, Japan, paper III-1, July 14 - 16, 1993.
16. J. A. Wolk, J. W. Ager III, K. J. Duxstad, E. E. Haller, N. R. Taskar, D. R. Dorman, and D. J. Olego, *Applied Physics Letters*, Vol. 63, No. 20, pp. 2756 - 2758 (15 November 1993).
17. N. M. Johnson, C. Herring, and D. Bour, "Diffusivity of Positively Charged Hydrogen in GaAs," *Physical Review B*, Vol. 48, No. 24, pp. 18308 - 18311 (15 December 1993-II).

18. N. M. Johnson and C. Herring, "Diffusion of Charged Hydrogen in Semiconductors," Proceedings of the 17th International Conference on Defects in Semiconductors, Gmunden, Austria, 1993 (Trans Tech Publications, Switzerland, 1994), editors H. Heinrich and W. Jantsch, Materials Science Forum, Vols. 143-147, Part 2, pp. 867-872 (1994).
19. G. Roos, N. M. Johnson, C. Herring, and J. Walker, "Depth Distribution of Diffused Hydrogen in n-type GaAs," Proceedings of the 17th International Conference on Defects in Semiconductors, Gmunden, Austria, 1993 (Trans Tech Publications, Switzerland, 1994), eds. H. Heinrich and W. Jantsch, Materials Science Forum, Vols. 143-147, Part 2, pp. 933-938 (1994).
20. M. S. Brandt, N. M. Johnson, R. J. Molnar, R. Singh, and T. D. Moustakas, "Hydrogenation of p-type Gallium Nitride," *Applied Physics Letters*, Vol. 64, No. 17, pp. 2264 - 2266 (25 April 1994).
21. M. S. Brandt, J. W. Ager III, W. G. Götz, N. M. Johnson, J. S. Harris Jr., R. J. Molnar, and T. D. Moustakas, "Local Vibrational Modes in Mg-doped Gallium Nitride," *Physical Review B*, Vol. 49, No. 20, pp. 14758-14761 (15 May 1994-II).
22. M. S. Brandt, N. M. Johnson, R. J. Molnar, R. Singh, and T. D. Moustakas, "Hydrogenation of Gallium Nitride," (Materials Research Society, Pittsburgh, PA, 1994), eds. M. O. Manasreh, H. J. von Bardeleben, G. S. Pomrenke, M. Lannoo, and D. N. Talwar, Materials Research Society Symposium Proceedings, Vol. 325, pp. 341 - 346.
23. N. M. Johnson, C. Herring, and C. G. Van de Walle, "Inverted Order of Acceptor and Donor Levels of Monatomic Hydrogen in Silicon," *Physical Review Letters*, Vol. 73, No. 1, pp. 130-133 (4 July 1994).

24. W. Götz, N. M. Johnson, H. Amano, and I. Akasaki, "Deep Level Defects in n-type GaN," *Applied Physics Letters*, Vol. 65, No. 4, pp. 463 - 465 (25 July 1994).
25. Y. P. Fan, J. Han, L. He, R. L. Gunshor, M. S. Brandt, J. Walker, N. M. Johnson, and A. V. Nurmikko, "Observations on the Limits to p-type Doping in ZnSe," *Applied Physics Letters*, Vol. 65, No. 8, pp. 1001 - 1003 (22 August 1994).
26. M. D. McCluskey, E. E. Haller, J. Walker, and N. M. Johnson, "Spectroscopy of Hydrogen-related Complexes in GaP:Zn," *Applied Physics Letters*, Vol. 65, No. 17, pp. 2191-2192 (24 October 1994).
27. P. A. Fisher, E. Ho, J. L. House, G. S. Petrich, L. A. Kolodziejski, M. S. Brandt, and N. M. Johnson, "n-type and p-type Doping of ZnSe with Gas Source Molecular Beam Epitaxy," Compound Semiconductor Epitaxy (Materials Research Society, Pittsburgh, PA, 1994), eds. C. W. Tu, L. A. Kolodziejski, and V. R. McCrary, Materials Research Society Symposium Proceedings Series, Vol. 340, pp. 451 - 456.
28. W. K. Götz and N. M. Johnson, "Deep Level Transient Spectroscopy: A Case Study on GaAs," in Characterization in Compound Semiconductor Processing (Butterworth-Heinemann, Boston, 1995), eds. Y. Strausser and G. E. McGuire, chap. 6 (pp. 109 - 123).
29. N. M. Johnson, C. Herring, and C. G. Van der Walle, "Isolated Hydrogen in Silicon--A Large Negative-U System," Proceedings of the 22nd International Conference on the Physics of Semiconductors (World Scientific Publishing Co. Pte. Ltd., Singapore, 1995), Vancouver, B.C., August 15 - 19, 1994, pp. 2227-2234.
30. J. Neugebauer and C. G. Van de Walle, "Atomic Geometry and Electronic Structure of Native Defects in GaN," *Physical Review B*, Vol. 50, No. 11, pp. 8067-8070 (15 September 1994).

31. J. Neugebauer and C. G. Van de Walle, "Defects and Doping in GaN," Proceedings of the 22nd International Conference on the Physics of Semiconductors (World Scientific Publishing Co Pte Ltd., Singapore, 1995), Vancouver, B.C., August 15 - 19, 1994, pp. 2327-2330.
32. W. K. Götz, N. M. Johnson, R. A. Street, H. Amano, and I. Akasaki, "Photoemission Capacitance Transient Spectroscopy on n-type GaN," *Applied Physics Letters*, Vol. 66, No. 11, pp. 1340-1342 (13 March 1995).
33. E. Ho, P. A. Fischer, J. L. House, G. S. Petrich, L. A. Kolodziejski, J. Walker, and N. M. Johnson, "Hydrogen Passivation in Nitrogen- and Chlorine-doped ZnSe Films Grown by Gas Source Molecular Beam Epitaxy," *Applied Physics Letters*, in press.
34. M. D. McCluskey, E. E. Haller, J. Walker, and N. M. Johnson, "Local Vibrational Mode Spectroscopy of Zinc-Hydrogen Complexes in GaP," Proceedings of the 21st International Symposium on Compound Semiconductors, in press.
35. J. Neugebauer and C. G. Van de Walle, "Native Defects and Impurities in Cubic and Wurtzite GaN," in Diamond, SiC and Nitride Wide Bandgap Semiconductors (Materials Research Society, Pittsburgh, Pennsylvania, 1995), eds. C. H. Carter Jr., G. Gildenblat, S. Nakamura, and R. J. Nemanich, Materials Research Society Symposia Proceedings, Vol. 339, in press.

APPENDIX III.
LIST OF PRESENTATIONS

1. G. Roos, N. M. Johnson, C. Herring, and J. S. Harris, Jr., "Dissociation Kinetics of Hydrogen-neutralized Si Donors and DX Centers in AlGaAs," 16th International Conference on Defects in Semiconductors, Lehigh University, Bethlehem, Pennsylvania, 22-26 July 1991.
2. G. Roos, N. M. Johnson, C. Herring, H. F. Chung, R. L. Thornton, and J. S. Harris, Jr., "Hydrogen Passivation and Reactivation of Se Dopants in AlGaAs," Electrochemical Society Meeting, Phoenix, Arizona, 13-18 October 1991.
- 3.* N. M. Johnson, "Recent Studies of Hydrogen in Silicon and III-V Semiconductors," Workshop on Hydrogen Migration and the Stability of Hydrogen Related Complexes in Crystalline Semiconductors, Horben bei Freiburg, Federal Republic of Germany, 3-6 November 1991.
- 4.* E. E. Haller, "Hydrogen in Semiconductors: What do we know, what should we know?," Workshop on Hydrogen Migration and the Stability of Hydrogen Related Complexes in Crystalline Semiconductors, Horben bei Freiburg, Federal Republic of Germany, 3-6 November 1991.
5. G. Roos, N. M. Johnson, Y. C. Pao, J. S. Harris, Jr., and C. Herring, "Hydrogen Passivation of Si and Be Dopants in InAlAs," Symposium on Advanced III-V Compound Semiconductor Growth, Processing and Devices, Fall Meeting of the Materials Research Society, Boston, Massachusetts, 2-6 December 1991.

* Invited presentation.

6. G. Roos, N. M. Johnson, Y. C. Pao, J. S. Harris, Jr., and C. Herring, "Hydrogenation and Passivation of Si- and Be-dopants in $\text{In}_{0.52}\text{Al}_{0.48}\text{As}$," March Meeting of the American Physical Society, Indianapolis, Indiana, March 16-20, 1992.
- 7.* N. M. Johnson, "Hydrogen in Compound Semiconductors," Symposium on Defect Engineering in Semiconductor Growth, Processing, and Device Technology, Spring Meeting of the Materials Research Society, San Francisco, California, April 26 - May 1, 1992.
8. G. Roos, N. M. Johnson, C. Herring, and J. S. Harris, Jr., "Hydrogen Passivation and Reactivation of DX Centers in Se-doped and Si-doped AlGaAs -- A Comparison," Symposium on Defect Engineering in Semiconductor Growth, Processing, and Device Technology, Spring Meeting of the Materials Research Society, San Francisco, California, April 26 - May 1, 1992.
9. S. M. Lord, G. Roos, B. Pezeshki, J. S. Harris, Jr., and N. M. Johnson, "Hydrogen Passivation of Defects in $\text{InGaAs}/\text{Al}_x\text{Ga}_{1-x}\text{As}$ Quantum Wells," Symposium on Defect Engineering in Semiconductor Growth, Processing, and Device Technology, Spring Meeting of the Materials Research Society, San Francisco, California, April 26 - May 1, 1992.
- 10.* E. E. Haller, "Hydrogen in Compound Semiconductors," 12th Symposium on Alloy Semiconductor Physics and Electronics, Izunagaoka, Japan, July 14 - 16, 1993.
- 11.* N. M. Johnson, "Hydrogen in Semiconductors," 1993 Gordon Research Conference on Metal-Hydrogen Systems, Tilton, New Hampshire, July 19 - 23, 1993.

* Invited presentation.

12. N. M. Johnson and C. Herring, "Diffusion of Charged Hydrogen in Semiconductors," 17th International Conference on Defects in Semiconductors, Gmunden, Austria, July 18 - 23, 1993.
13. G. Roos, N. M. Johnson, C. Herring, and J. Walker, "Depth Distribution of Diffused Hydrogen in n-type GaAs," 17th International Conference on Defects in Semiconductors, Gmunden, Austria, July 18 - 23, 1993.
- 14.* N. M. Johnson, "Electron Emission from Migrating Deep-level Defects Determined by Capacitance Transient Spectroscopy," Institute of Applied Physics, University of Erlangen-Nürnberg, Erlangen, Germany, July 26, 1993.
15. N. M. Johnson, "Migration of Charged Hydrogen in Semiconductors," Department of Materials Science and Engineering, Massachusetts Institute of Technology, Cambridge, Massachusetts, September 13, 1993.
- 16.* C. G. Van de Walle, "Doping of Wide-band-gap Semiconductors," University of Rome Tor Vergata, Rome, Italy, September 15, 1993.
- 17.* C. G. Van de Walle, "Solubilities, Compensation, and Doping Limits in Compound Semiconductors," European Research Conference on Electronic Structure of Solids: Surfaces, Interfaces, and Localized Defects, Thessaloniki, Greece, September 18, 1993.
- 18.* C. G. Van de Walle, "Doping of Wide-band-gap Semiconductors," University of Erlangen, Erlangen, Germany, September 24, 1993.
- 19.* C. G. Van de Walle, "Doping of Wide-band-gap Semiconductors," University of California at Davis Physics Department, Davis, CA, October 11, 1993.

* Invited presentation.

- 20.* N. M. Johnson, "Hydrogen in GaN and ZnSe," AFOSR Contractors' Meeting: Wide Bandgap Semiconductor Materials and Devices, Wright-Patterson AFB, Dayton, Ohio, October 19, 1993.
21. M. S. Brandt, N. M. Johnson, R. J. Molnar, R. Singh, T. D. Moustakas, "Hydrogenation of Gallium Nitride," Fall Meeting of the Materials Research Society, Boston, MA, November 29, 1993.
- 22.* N. M. Johnson, "Hydrogen in Semiconductors," 22nd Annual Electronic Materials Symposium, San Jose, California, March 21, 1994.
- 23.* N. M. Johnson, "Monatomic Hydrogen in Silicon--Tracking a Elusive Interloper," Department of Electrical Engineering and Computer Science, University of California at Davis, Davis, California, May 6, 1994.
24. N. M. Johnson, C. Herring, and C. G. Van de Walle, "Isolated Hydrogen in Silicon -- A Large Negative-U System," 22nd International Conference on the Physics of Semiconductors, Vancouver, Canada, August 15 - 19, 1994.
- 25.* N. M. Johnson, "Diffusion and Charge States of Isolated Hydrogen in Si and GaAs," 1994 Gordon Research Conference on Point Defects, Line Defects and Interfaces in Semiconductors, Plymouth, New Hampshire, August 1 - 5, 1994.
- 26.* C. G. Van de Walle, "Wide-band-gap II-VI Compounds," Lawrence Berkeley Laboratory, Berkeley, CA, February 19, 1994.
27. J. Neugebauer and C. G. Van de Walle, "Electronic and Atomic Structure of Native Defects and Impurities in GaN," March Meeting of the American Physical Society, Pittsburgh, PA, March 21, 1994.

* Invited presentation.

28. J. Neugebauer and C. G. Van de Walle, "Native Defects and Impurities in Cubic and Wurtzite GaN," Materials Research Society, San Francisco, CA, April 4, 1994.
- 29.* C. G. Van de Walle, "Defects and Doping in Wide-band-gap Semiconductors," Princeton University, Department of Electrical Engineering, Princeton, NJ, May 23, 1994.
30. Y. P. Fan, J. Han, L. He, R. L. Gunshor, M. S. Brandt, J. Walker, and N. M. Johnson, "Comparison of Nitrogen Doping of ZnSe and ZnTe -- Limited by Self Compensation or Solubility?," 1994 Electronic Materials Conference, University of Colorado, Boulder, CO, June 22-24, 1994.
31. P. A. Fisher, E. Ho, J. L. House, G. S. Petrich, L. A. Kolodziejski, M. S. Brandt, J. Walker, and N. M. Johnson, "Incorporation of Hydrogen in ZnSe:N and ZnSe:Cl Grown by Gas Source Molecular Beam Epitaxy," 1994 Electronic Materials Conference, University of Colorado, Boulder, CO, June 22-24, 1994.
32. J. Neugebauer and C. G. Van de Walle, "Dopants and defects in GaN," Sixth International Conference on Shallow Level Centers in Semiconductors, Berkeley, CA, August 10, 1994.
- 33.* C. G. Van de Walle and D. B. Laks, "Nitrogen doping in ZnTe and ZnSe," Sixth International Conference on Shallow Level Centers in Semiconductors, Berkeley, CA, August 10, 1994.
34. J. Neugebauer and C. G. Van de Walle, "Defects and Doping in GaN," 22nd International Conference on the Physics of Semiconductors, Vancouver, BC, August 15, 1994.

* Invited presentation.

- 35.* C. G. Van de Walle, "Defects, Impurities, and Doping Levels in Semiconductors," 5th Italian-Swiss Workshop on Computational Condensed Matter Physics, Sta. Margherita di Pula, Italy, September 8, 1994.
36. M. D. McClusky, E. E. Haller, J. Walker, and N. M. Johnson, "Local Vibrational Mode Spectroscopy of Zinc-Hydrogen Complexes in GaP," 21st International Symposium on Compound Semiconductors, San Diego, CA, September 18 - 22, 1994.
37. J. Neugebauer and C. G. Van de Walle, "Native Defects and Impurities in GaN," Second Workshop on Wide Bandgap Nitrides, St. Louis, MO, October 17, 1994.
38. M. D. McClusky, E. E. Haller, J. Walker, and N. M. Johnson, "Local Vibrational Mode Spectroscopy of Group II Acceptor-Hydrogen Complexes in GaP," March Meeting of the American Physical Society, San Jose, CA, March 20-24, 1995.

* Invited presentation.