

# NAVAL POSTGRADUATE SCHOOL MONTEREY, CALIFORNIA

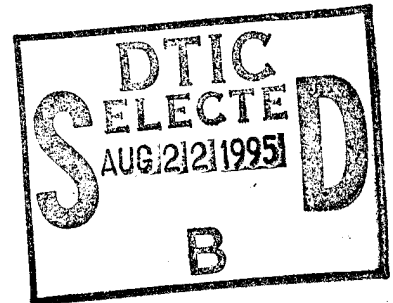

## THESIS

**ACTIVITY BASED COSTING AT THE  
NAVAL POSTGRADUATE SCHOOL**

by

Stephen A. Belgum

March 1995

Principal Advisor:

Kenneth J. Euske

**Approved for public release; distribution is unlimited.**

19950821 027

# REPORT DOCUMENTATION PAGE

Form Approved OMB No. 0704-0188

Public reporting burden for this collection of information is estimated to average 1 hour per response, including the time for reviewing instruction, searching existing data sources, gathering and maintaining the data needed, and completing and reviewing the collection of information. Send comments regarding this burden estimate or any other aspect of this collection of information, including suggestions for reducing this burden, to Washington Headquarters Services, Directorate for Information Operations and Reports, 1215 Jefferson Davis Highway, Suite 1204, Arlington, VA 22202-4302, and to the Office of Management and Budget, Paperwork Reduction Project (0704-0188) Washington DC 20503.

1. AGENCY USE ONLY (Leave blank)	2. REPORT DATE March 1995	3. REPORT TYPE AND DATES COVERED Master's Thesis	
4. TITLE AND SUBTITLE ACTIVITY BASED COSTING AT THE NAVAL POSTGRADUATE SCHOOL		5. FUNDING NUMBERS	
6. AUTHOR(S) Stephen A. Belgum		8. PERFORMING ORGANIZATION REPORT NUMBER	
7. PERFORMING ORGANIZATION NAME(S) AND ADDRESS(ES) Naval Postgraduate School Monterey CA 93943-5000		10. SPONSORING/MONITORING AGENCY REPORT NUMBER	
9. SPONSORING/MONITORING AGENCY NAME(S) AND ADDRESS(ES)		11. SUPPLEMENTARY NOTES The views expressed in this thesis are those of the author and do not reflect the official policy or position of the Department of Defense or the U.S. Government.	
12a. DISTRIBUTION/AVAILABILITY STATEMENT Approved for public release; distribution is unlimited.		12b. DISTRIBUTION CODE	
13. ABSTRACT (maximum 200 words)  <p style="text-align: center;">DTIC QUALITY INSPECTED 2</p>			
14. SUBJECT TERMS Activity Based Costing, Activity Based Management, Resource, Activity, Output, Output Costing		15. NUMBER OF PAGES 155	
17. SECURITY CLASSIFICATION OF REPORT Unclassified		16. PRICE CODE	
18. SECURITY CLASSIFICATION OF THIS PAGE Unclassified	19. SECURITY CLASSIFICATION OF ABSTRACT Unclassified	20. LIMITATION OF ABSTRACT UL	

NSN 7540-01-280-5500

Standard Form 298 (Rev. 2-89)  
Prescribed by ANSI Std. Z39-18 298-102



Approved for public release; distribution is unlimited.

**ACTIVITY BASED COSTING AT THE  
NAVAL POSTGRADUATE SCHOOL**

Stephen A. Belgium  
Captain, United States Marine Corps  
B.A., Seattle Pacific University, 1983

Submitted in partial fulfillment  
of the requirements for the degree of

**MASTER OF SCIENCE IN MANAGEMENT**

from the

NAVAL POSTGRADUATE SCHOOL  
March 1995

Author:

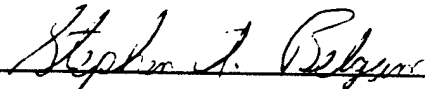
  
\_\_\_\_\_  
Stephen A. Belgium

Approved by:

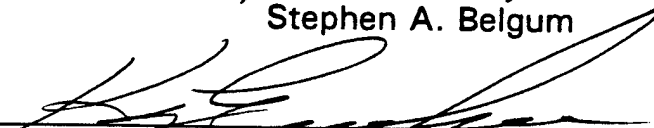
  
\_\_\_\_\_  
Kenneth J. Euske, Principal Advisor

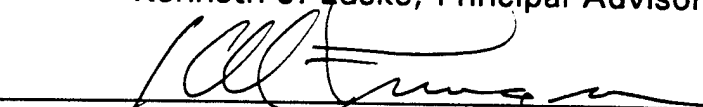
  
\_\_\_\_\_  
James M. Fremgen, Associate Advisor

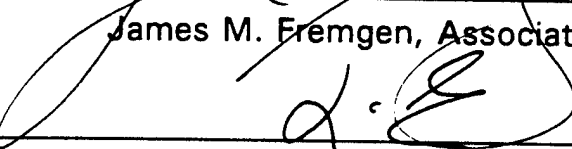
  
\_\_\_\_\_  
David Whipple, Chairman  
Department of Systems Management

Accession For	
NTIS GRA&I	<input checked="" type="checkbox"/>
DTIC TAB	<input type="checkbox"/>
Unannounced	<input type="checkbox"/>
Justification	
By _____	
Distribution/	
Availability Codes	
Dist	Avail and/or Special
A-1	



## **ABSTRACT**

**This thesis uses Activity Based Costing to develop a budgeting model for an academic department at the Naval Postgraduate School. The purpose of this Activity Based Costing model is to provide managers with a more effective means of justifying resources and to function as a budgeting tool. The model consists of three levels: resources, activities, and outputs. The model is a flexible tool that uses an activity based software package. This thesis demonstrates that the model tracks the processes of the department and identifies activities which drive costs. An annual cost of each of the three outputs is determined.**



## TABLE OF CONTENTS

I. INTRODUCTION .....	1
A. OBJECTIVE .....	1
B. BACKGROUND .....	1
C. THE RESEARCH QUESTION .....	4
D. SCOPE, LIMITATIONS, AND ASSUMPTIONS .....	5
II. ACTIVITY COSTING APPROACH .....	7
A. AN ACTIVITY COSTING APPROACH TO OUTPUT COSTING .	7
1. Decision Making using Managerial Accounting .....	7
2. Relevance of Strategic Cost Analysis .....	7
3. The Activity Based Costing Method .....	8
4. Applicability of Activity Based Costing to Organizations with Multiple Outputs .....	9
B. THE ACTIVITY ANALYSIS RATIONALE .....	10
1. The Raffish and Turney Model .....	10
2. The Cooper, Kaplan, et al, Model .....	12
3. Unit, Batch, Output, and Facility Activities .....	14
III. METHODOLOGY .....	17
A. ARCHIVAL STRATEGY .....	17
B. OPINION STRATEGY .....	18
C. EMPIRICAL STRATEGY .....	20
D. ANALYTICAL STRATEGY .....	20

<b>IV. THE ACTIVITY BASED COSTING ANALYSIS AND MODEL FOR THE</b>	
<b>MECHANICAL ENGINEERING DEPARTMENT</b> .....	<b>23</b>
<b>A. INTRODUCTION</b> .....	<b>23</b>
<b>B. IDENTIFY OUTPUTS (STEP ONE)</b> .....	<b>27</b>
<b>C. IDENTIFY ACTIVITIES (STEP TWO)</b> .....	<b>27</b>
<b>D. IDENTIFY RESOURCES (STEP THREE)</b> .....	<b>28</b>
<b>E. LINK OUTPUTS TO ACTIVITIES TO RESOURCES</b>	
<b>(STEP FOUR)</b> .....	<b>28</b>
<b>F. DETERMINE OPERATIONAL AND FINANCIAL FLOWS</b>	
<b>(STEP FIVE)</b> .....	<b>29</b>
<b>G. INPUT ALL DATA INTO AN ACTIVITY SOFTWARE PACKAGE</b>	
<b>(STEP SIX)</b> .....	<b>30</b>
<b>H. ACTIVITY BASED COSTING MODEL</b> .....	<b>30</b>
<b>1. Outputs</b> .....	<b>30</b>
<b>a. Graduates</b> .....	<b>30</b>
<b>b. Research Products</b> .....	<b>31</b>
<b>c. Support Outputs</b> .....	<b>32</b>
<b>2. Activities</b> .....	<b>33</b>
<b>a. Teaching Classes (Lecture, Design, Laboratory)</b> ..	<b>34</b>
<b>b. Research</b> .....	<b>36</b>
<b>c. Experiments</b> .....	<b>36</b>
<b>d. Administrative Management</b> .....	<b>37</b>
<b>e. Naval Engineering Curricular Management</b> .....	<b>38</b>
<b>f. All Other Activities</b> .....	<b>38</b>
<b>3. Resources</b> .....	<b>39</b>
<b>a. Faculty Labor</b> .....	<b>39</b>
<b>b. Staff Labor</b> .....	<b>41</b>
<b>c. Military Labor</b> .....	<b>41</b>
<b>4. Modeling Software Package Description</b> .....	<b>42</b>

5. Model Software Information .....	43
a. Time Periods .....	43
b. Units .....	44
c. Cost Categories .....	45
d. Multipliers .....	46
e. Tags .....	46
f. Capacities .....	47
g. Relationships .....	47
I. MODEL VALIDATION .....	47
J. OUTPUT COSTS FOR FISCAL YEAR 1994 .....	49
1. Graduates .....	50
2. Research Products .....	51
3. Support Outputs .....	51
V. CONCLUSIONS AND RECOMMENDATIONS .....	53
A. CONCLUSIONS .....	53
1. Activity Based Costing Model Identifies Activities Which Drive Costs .....	53
2. Activity Based Costing Model Provides A Justification For Resource Use .....	54
3. Activity Based Costing Model May Function As A Budgeting Tool .....	54
B. RECOMMENDATIONS FOR APPLICABILITY .....	54
1. Mechanical Engineering Department .....	54
2. Other Departments .....	55
3. Tenant Commands .....	55
4. Naval Postgraduate School .....	56
5. Department of the Navy Academic Institutions .....	57
C. FUTURE RESEARCH .....	57

LIST OF REFERENCES .....	59
APPENDIX A. GRAPHICAL DEPICTION OF EACH BOX .....	63
APPENDIX B. MODEL INFORMATION .....	99
APPENDIX C. MODEL NETWORK REPORT .....	103
APPENDIX D. ATTRIBUTE TAGS BOX REPORT .....	111
APPENDIX E. MULTIPLIER REPORT .....	113
APPENDIX F. FLOW AND UNIT COST REPORTS .....	115
APPENDIX G. DETAILED FLOWS RESULTS REPORT .....	123
APPENDIX H. TOTAL FINANCIAL RESULTS .....	131
APPENDIX I. FINANCIAL RESULTS BY COST CATEGORY .....	133
INITIAL DISTRIBUTION LIST .....	137

## LIST OF FIGURES

<b>Figure 2-1. Cost Assignment View</b>	
Source: Turney, 1991, page 81 . . . . .	11
<b>Figure 2-2. Process View</b>	
Source: Turney, 1991, page 81 . . . . .	11
<b>Figure 2-3. Traditional Two Stage Approach</b>	
Source: Cooper, Kaplan, et al., 1992, page 9 . . . . .	12
<b>Figure 2-4. Activity Based Costing Approach</b>	
Source: Cooper, Kaplan, et al., 1992, page 10 . . . . .	13
<b>Figure 4-1. ABC Model Schematic for the Mechanical Engineering</b>	
<b>Department . . . . .</b>	<b>24</b>



## LIST OF TABLES

<b>Table 2-1. Levels of Activities</b>	
Source: Rotch, 1991 . . . . .	14
<b>Table 3-1. Research Methodology</b>	
Source: Buckley, 1976 . . . . .	17
<b>Table 4-1. Department Outputs</b> . . . . .	30
<b>Table 4-2. Department Activities</b> . . . . .	34
<b>Table 4-3. Department Resources</b> . . . . .	39
<b>Table 4-4. Model Units</b> . . . . .	45
<b>Table 4-5. Output Costs</b> . . . . .	50



## **ACKNOWLEDGMENT**

The author thanks his wife, Lynda Belgum, for her continued support during this period of research and writing. Without her constant backing, it would not have been possible to complete this thesis.

Additionally, the author acknowledges Professor Ken Euske for his guidance, patience, and motivation while conducting this research project.

## **I. INTRODUCTION**

### **A. OBJECTIVE**

The objective of this thesis was to develop an Activity Based Costing system for an academic department. The Mechanical Engineering department at the Naval Postgraduate School was the site for the introduction of Activity Based Costing in an academic department.

The model that was developed is designed to be responsive to managers' requests to understand the operational and financial flows in conducting the mission of the Naval Postgraduate School, which produces graduates, research products, and support outputs (such as providing data to the Base Realignment And Closure Commission (BRAC)). The model should provide for more effective resource justification and function as a budgeting tool for future requirements.

### **B. BACKGROUND**

The school's charter, SECNAVINST 1524.2A, Policies Concerning the Naval Postgraduate School, states that the purpose of the Naval Postgraduate School is to increase the combat effectiveness of the United States Navy and the United States Marine Corps. The Naval Postgraduate School increases combat effectiveness by offering post-baccalaureate degree and non-degree programs which are not available at other universities, conducting naval and maritime research, and providing faculty to advise and support the Department of the Navy (DoN).

Key elements in the implementation of this mission include the ability to develop unique programs and curricula, and the flexibility to rapidly meet the ever-changing needs of the Fleet Marine Force and the Fleet. The Naval Postgraduate School offers programs such as Anti-Submarine Warfare and Naval ship systems engineering and design programs to satisfy continuing

needs within the United States Navy. As threats to the United States armed forces change from a world dominated by two superpowers to multiple smaller threats in the post-cold war era, the Naval Postgraduate School must respond with flexibility to change educational subjects in order to address the particular needs of the military (SECNAVINST 1524.2A).

The changing roles and missions for the Department of Defense (DoD) mean it must provide better justification of its use of resources to the Congress of the United States and ultimately to the American citizens (Goldich and Daggett, 1990). Pay as you go limits for all federally funded programs mean tough choices for the United States Congress as it allocates the federal government's budget (Keith, 1992).

Defense spending has decreased in real terms since 1986 (Office of Technology Assessment, 1992). As a percentage of the Gross Domestic Product, defense spending by the United States federal government has gone from a recent high of 6.3 percent in 1986, to a projected low of 3.0 percent in 1999 (Congressional Budget Office, 1993). Meanwhile, entitlement spending continues to grow as a percentage of the budget which further constrains all other spending (Congressional Budget Office, 1993). All of these factors work to create a situation where resource justification, allocation, and consumption by the military is increasingly being questioned.

How can we as military managers and civilian managers within the Department of Defense provide stronger and more defensible justification for resources in an era of increasing budget pressure and declining real dollar spending? One way is to gain a clearer understanding of the processes that produce the products or services in our organizations. This knowledge of processes can then be used to identify specific activities and the decisions which drive or cause processes and activities. Costs can then be associated with the activities and the outputs. It is with this framework that the author began an inquiry into the Naval Postgraduate School.

The Naval Postgraduate School uses some DoN accounting systems. DoN accounting systems lack integration and are antiquated. These systems exist to record expenditures, pay members and suppliers, and perform other functions. (Jay, 1994) These systems may be useful to the comptroller who must assure the obligation and expenditure of one hundred percent of the organizations' appropriated funds in a given fiscal year without violating any regulations (Kalmar, 1994). However, these systems do not provide ready-to-use information for budgeting, resource justification, and decision making purposes at the sub-cost center level (Jay, 1994). The lack of useful accounting system information for decision making within DoN for lower level managers provides an opportunity to make use of Activity Based Costing and Activity Based Management.

Activity Based Costing is a system of costing which disaggregates organizational processes into detailed activities. Costs are assigned to outputs based on the sum of the costs of activities required to produce each output (Deakin and Maher, 1991). An Activity Based Costing system, by itself, is passive. In contrast, Activity Based Management involves actions taken by managers within an organization using the information gained from an activity based costing system.

Activity Based Costing and Activity Based Management have gained increasing interest by the public sector and private organizations. A number of books have been written on the subject in the last few years, for example *Relevance Lost* (Johnson and Kaplan, 1987), *Relevance Regained* (Johnson, 1992), *Implementing Activity Based Costing* (Collins, 1991), *Implementing Activity Based Cost Management: Moving from Analysis to Action* (Cooper, et al, 1992), and *Common Cents: The ABC Performance Breakthrough* (Turney, 1991). Additionally, consultants market different versions of software which is designed to implement Activity Based Costing in their customers' organizations (Management Accounting, June 1994).

The author's search of the literature did not identify a specific application of Activity Based Costing in the academic arena with the intent to provide a resource justification, budgeting and decision making tool for department managers. However, on the Naval Postgraduate School campus, a financial management faculty member had conducted an activity analysis of the academic departments. That information was collected, and then further data was gathered in the research in order to learn more about the operational process flows and associated financial costs at the Naval Postgraduate School, especially the processes that result in outputs. The research problem was then narrowed to one specific academic department and its outputs.

The three outputs identified as produced by the Mechanical Engineering department are graduates, research products, and support outputs. Although a primary output for the department is graduates, the Mechanical Engineering program is approximately 29 months long, including a refresher and nine academic quarters. Thus it is useful to track annual costs of students.

Students in the program were defined to be in the refresher or first seven quarters of the curriculum or in the eighth and ninth quarters and were designated Students-Average On Board and Thesis Students-Average On Board, respectively. The total number of students in the department were measured by the unit of average on board (AOB). This measure shows the total number of students in the Mechanical Engineering program, on average, on any day in the year.

### **C. THE RESEARCH QUESTION**

The primary research question addressed in this thesis is: Can a model be developed that identifies activities which drive costs in an academic department at the Naval Postgraduate School?

Additionally, two subsidiary research questions were asked. To what extent can the Activity Based Costing model be an effective tool for managers to justify resources by identifying the specific activities that drive costs in an academic department? To what extent will this Activity Based Costing model be an effective tool for budgeting by managers?

#### **D. SCOPE, LIMITATIONS, AND ASSUMPTIONS**

Academic departments at the Naval Postgraduate School are complicated and incorporate many processes. In order to derive a workable model that could be supported with available software, some aggregation of activities and subprocesses was necessary. This means that some of the activities and processes conducted in the department are much more detailed than indicated in the model. The subprocesses may consist of dozens of activities that are too detailed for the purpose of this thesis. The model can be expanded in the future, using more robust software, to identify those subprocesses as the need arises.

A steady state was assumed for Fiscal Year 1994. Thus, each student moving to the eighth quarter (thesis student) was assumed to be replaced by a student and each thesis student leaving the Mechanical Engineering department (graduate) was assumed to be replaced by another thesis student. This assumption reduces model complexity and thus fitted more readily into the available software.

Utilities usage and costs and maintenance costs were derived from an engineering facilities study conducted by the Public Works department on 28 February, 1991 (McGuire, 1994). A figure of \$2.40 of utility usage per square foot per year of building space was estimated from the usage data (McGuire, 1994). Each building was designated as laboratory space or instructional space in the study. This introduces some inaccuracy because some buildings include a combination of laboratory and instructional spaces

in addition to office and lounge areas. However, the study did not include these breakdowns by building. Maintenance costs of \$1.20 per square foot per year and \$.20 per square foot for three months of heating were used in the study (McGuire, 1994).

Costs associated with sustaining the facility such as the salaries of the Provost, Director of Programs, Public Works Officer, other line managers, and the Admiral are not included in the analysis. Also, costs for library usage, local telephone usage, and Federal Telecommunications System 2000 are not included in the model. Commercial long distance usage costs of \$250 per month were provided by the department Chairman and included in the model. The costs associated with sustaining the facility, such as library usage, the balance of the telephone usage costs, and senior managers' salaries can be added to the model in the future. The Activity Based Costing model can be improved by including the cost of these resources.

The Activity Based Costing model tracks nonvalue added activity to support outputs. An estimate of nonvalue work as a percentage of the faculty, staff, and military workyears were provided by the department chairman and included in the model.

The Activity Based Costing model described in this thesis identifies operational and financial flows, and output costs in the Mechanical Engineering department. The output costs are estimates. Changes in the model will effect the estimates. For instance, separately identifying student research outputs, which is not done in this model, can have a significant effect on the unit cost of the Students-Average On Board, Thesis Students-Average On Board, and on the research products. Other issues, such as how to classify an administrative assistant's activity can add to or subtract from work required to generate outputs and thus affect output costs.

## **II. ACTIVITY COSTING APPROACH**

### **A. AN ACTIVITY COSTING APPROACH TO OUTPUT COSTING**

#### **1. Decision Making using Managerial Accounting**

Recently, articles have appeared which describe the lack of relevance of management accounting to organizational management decision making. Johnson and Kaplan (1987) discuss the problems with management use of current accounting systems. Among their concerns was that management accounting was not providing useful, timely information for process control, product costing, and performance evaluation of managers. Cooper and Kaplan (1988) argue that accounting was concentrating on information for short-term decisions based on variable or incremental costs even though decisions such as product pricing are long-term. These criticisms of costing systems indicated a potential lack of relevance and a need to focus on strategic issues.

#### **2. Relevance of Strategic Cost Analysis**

Recent work (Johnson, 1992, Shank and Govindarajan, 1989) has attempted to address this potential lack of relevance by focusing on strategic issues through strategic cost analysis. Strategic costs are generally longer-term costs that relate to outputs, and include all types of costs, not just direct product costs. Johnson (1992) argues that management information derived from most accounting systems will lead to dysfunctional results whereby managers will manipulate processes in order to improve their performance evaluation. In his view, only by focusing on the customer and removing barriers and obstacles in organizational processes can sustainable long-term success (business profitability) be achieved.

Sounding the same warning about management information, Shank and Govindarajan (1989) propose what they call a new outlook for

**management accounting: strategic cost analysis.** In this framework, cost analysis is said to take on a broader context; emphasis is placed on the integration of strategic issues and cost analysis. Shank and Govindarajan propose that short-term decisions like production efficiency can be made by analyzing variances within a standard costing system.

However, a broader understanding of an organization's costs is necessary for the organization's continued viability. Long-term costs will affect the long-term success of an organization. Managers should attempt to understand these long-term costs, if they envision long-term success. Activity Based Costing can help managers gain a better understanding of an organization's long-term or strategic costs. Strategic decision making can be accomplished using activity based output costing (Rotch, 1991).

In today's climate of declining budgets, Naval Postgraduate School managers need the best tools to effectively budget and make decisions for future requirements. This will mean planning for the long-term and projecting demand for new research topics, laboratories, computer networks, and human and fiscal resources. If a manager knows how costs will vary when requirements vary, then informed budgeting decisions can be made. The wise use of DoN resources are contingent upon understanding the broad implications of cost relationships, also offering an opportunity for the use of Activity Based Costing.

### **3. The Activity Based Costing Method**

The finance function at General Electric (GE) devised a method in the 1960's to figure costs caused or driven by activities, rather than the traditional method of assigning indirect and overhead costs to corporate functions such as marketing, production, or engineering based on some measure like labor (Johnson, 1992). This was found to be necessary because in some cases, labor costs did not vary directly with the majority of activities and therefore cost allocations based on that measure were grossly

inaccurate. GE also traced costs upstream to the driver of the activities. Usually, this was a cross-functional analysis because activities in one department would likely cause activities in other departments (Johnson, 1992).

Company management employed these costs, derived from activities, as management accounting information (Johnson, 1992). By so doing, they could manage costs in the company by controlling activities and drivers of activities which actually caused costs. This was a different approach than the use of standard product costing methods to control costs (Johnson, 1992).

Worthwhile as this management accounting information was to GE managers, the new method was not taken as far as it could have been because all the activity costs were not totalled in order to get an estimated output cost. The resurgence of Activity Based Costing in the 1980's focused not only on costs of activities and drivers, but also on estimations of output costs from summing all the costs of the generators of activities. Vast improvements in computer capability made this much easier in the 1980's than in the 1960's.(Johnson, 1992)

#### **4. Applicability of Activity Based Costing to Organizations with Multiple Outputs**

Activity Based Costing can be an effective tool in an organization that produces more than one output (Rotch, 1991). If only one service or product results from work processes, then all the costs associated with that organization must be borne by the one product. In this case, budgeting is simpler because changes in activities will be passed to the cost of the one output.

The Naval Postgraduate School produces more than one output: instruction, research products, support outputs, and tenant support are the school's four outputs. Thus, not all costs can be assigned to one output as

in a single product organization. To correctly assign costs to each product, the individual activity costs at the Naval Postgraduate School must be separated from the total and traced from the output back to the activity (cost) drivers. The Activity Based Costing model provides visibility of the costs caused by activities upstream from the output.

## **B. THE ACTIVITY ANALYSIS RATIONALE**

Consultants and academics have discussed the rationale and benefits of activity analysis. Two approaches to Activity Based Costing are presented below. Raffish and Turney describe the model by using two axes: a horizontal and a vertical. Cooper and Kaplan, et al., simply use two separate vertical diagrams to contrast the traditional accounting view of cost allocation versus the Activity Based Costing view.

### **1. The Raffish and Turney Model**

The first model is that developed by Raffish (1991) and Turney (1991). Raffish (1991) describes the Activity Based Costing model as containing two axes. The vertical or cost assignment view of this model is described and shown as follows (Figure 2-1):

The vertical part of the model...reflects the need for organizations to assign costs to activities and cost objects (including customers as well as products) in order to analyze critical decisions. These decisions include pricing, product mix, sourcing, product design decisions, and setting priorities for improvement efforts (Turney, 1991).

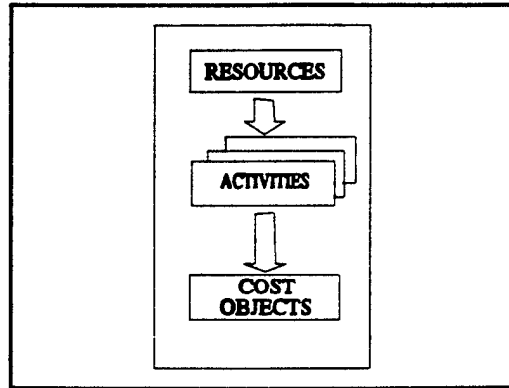

**Figure 2-1. Cost Assignment View**  
 Source: Turney, 1991, page 81

Turney continues on to explain the horizontal part of the model: the process view (Figure 2-2).

The process view reflects the need of organizations for a new category of information. This is information about events that influence the performance of activities and activity performance; that is, what causes work and how well it is done. Organizations can use this type of information to help improve performance and the value received by customers. (Turney, 1991)

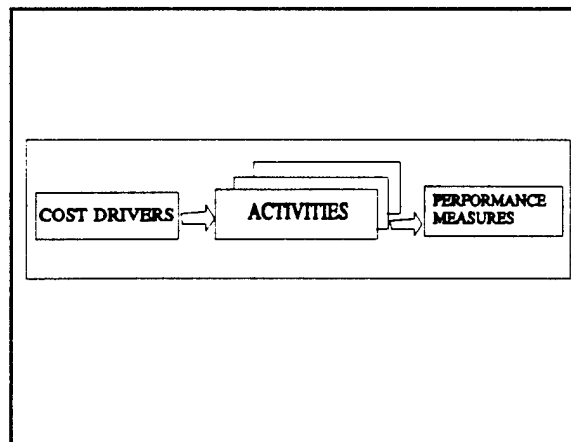

**Figure 2-2. Process View**  
 Source: Turney, 1991, page 81

## 2. The Cooper, Kaplan, et al, Model

The second model was developed by Cooper, Kaplan, et al. First, they discuss the traditional cost model, which uses a simple two-stage allocation of resources to cost pools and then to the outputs (Figure 2-3).

Traditional cost systems use a two-stage procedure to assign an organization's indirect and support expenses to outputs. Operating expenses are assigned first to cost pools and second, to the outputs of the production process. These traditional two-stage assignment procedures, however, distort reported costs considerably. The traditional systems assign costs from cost pools to outputs using volume drivers such as labor and machine hours, material purchases, and units produced. Because many indirect and support resources are not used in proportion to the number of output units produced, these traditional systems provide highly inaccurate measures of the costs of support activities used by individual outputs. (Cooper, Kaplan, et al., 1992)

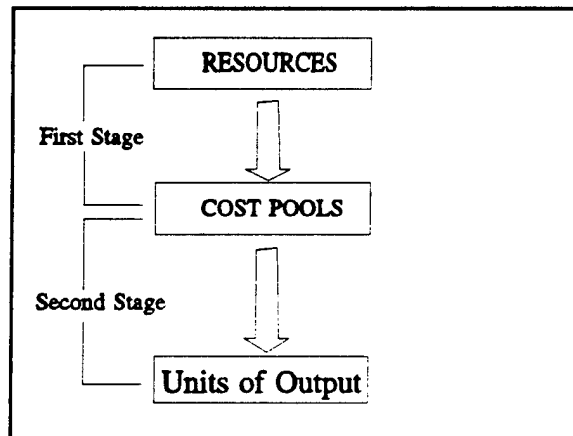

Figure 2-3. Traditional Two Stage Approach

Source: Cooper, Kaplan, et al., 1992, page 9

Next, Cooper, Kaplan, et al., describe their Activity Based Costing model which traces activities performed to the outputs which drive the need for those activities (Figure 2-4).

Activity-based cost systems differ from traditional systems by modeling the usage of all organizational resources on the activities performed by these resources and then linking the cost of these activities to outputs such as products, services, customers, and projects. In particular, activity-based systems measure more accurately the cost of activities not proportional to the volume of outputs produced. In manufacturing processes, four categories of activities can be identified:....unit, batch, product, and facility. (Cooper, Kaplan, et al., 1992)

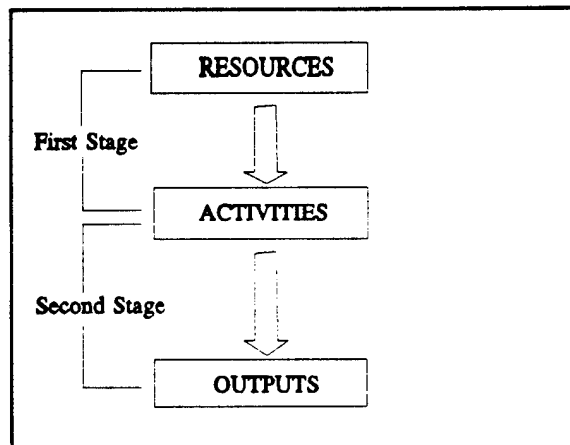

Figure 2-4. Activity Based Costing Approach  
Source: Cooper, Kaplan, et al., 1992, page 10

If the vertical axis of the Raffish and Turney model is superimposed on the horizontal axis, the model is similar to the one proposed by Cooper, Kaplan, et al. The claim that activity based systems are more accurate than traditional systems is open to question. It is clear, however, that a costing system that closely models the underlying transformation process can provide the decision maker useful information.

### 3. Unit, Batch, Output, and Facility Activities

Table 2-1 lists the levels of activities.

<b>UNIT LEVEL</b>	<b>Caused by numbers of output</b>
<b>BATCH LEVEL</b>	<b>Caused by batches of output</b>
<b>PRODUCT SUSTAINING</b>	<b>Required to maintain the entire product</b>
<b>FACILITY SUSTAINING</b>	<b>Required to maintain the entire facility</b>

**Table 2-1. Levels of Activities**

Source: Rotch, 1991

Unit level activities are performed primarily because of the units of output. For one additional unit of output produced, one additional unit level activity must occur. For example, one unit level activity is the editorial assistance/typing pool in which one more proposal needing to be typed would require an average of two more hours of work. Another unit level activity is handling travel orders and travel claims. A faculty member who makes a trip first must ask for a set of travel orders from the travel technicians to receive plane tickets and rental car authorization; a travel claim is completed after the trip by the faculty member and the technician. So, each trip drives the need for the activity of preparing and processing a set of travel orders and claims.

Batch level activities are performed for batches of outputs. An example of a batch activity is teaching students: a new class section is scheduled when the number of students needing a class exceeds approximately 30. Another example of a batch level activity is handling supply requisitions for departmental supplies. The department is supplied as a whole. The need for supplies is driven by batches of experiments, class sections, and multiple administrative requirements.

Product sustaining activities are required to develop, market, or sustain the output as a whole and could theoretically only be avoided if the

output was no longer produced. The administrative and curricular office management activities within the academic departments which include the chairman's labor and the curricular officer's labor, respectively, are product sustaining. Other product sustaining activities include:

- **Maintaining faculty currency.** Faculty must maintain currency to teach students as a whole.
- **Program maintenance.** Maintenance of each department's curricula is usually needed every few quarters to update course and curricula materials.
- **Course and Program development.** New courses and programs are developed over a period of quarters and years. Among other reasons, the need for new courses and programs is driven by students.

Facility sustaining activities are required to operate or maintain the entire facility or to produce the outputs. Electricity, water, natural gas, laboratories, and classrooms are needed for production of an academic department's services in general, and are examples of facility activities. Additionally, the library provides its services to the entire school and thus benefits the Naval Postgraduate School and not just the Mechanical Engineering department. Other facility sustaining activities include the functions of the line managers, the superintendent, the provost, and the deans. A share of the costs of these activities must be included to derive an activity cost (full cost) for outputs within one academic department. However, the tracing of the costs of these facility level activities is beyond the scope of this thesis.

**Another way for managers to view all of the above levels of activities is to consider them as contributing (value added) or not contributing (nonvalue added) to the departments outputs. Most of the activities in a department (one would hope) are value added. A few activities may be nonvalue added because they contribute nothing productive to the department's outputs. The nonvalue added operational and financial flows can be tracked and collected in a separate output box. For the Mechanical Engineering department, a third output labeled Support was included in the Activity Based Costing model so that the flows and costs of all nonvalue activities can be attributed separately from the two primary outputs.**

### III. METHODOLOGY

The research methodology included four research strategies: archival, opinion, empirical, and analytical as listed in Table 3-1.

1	Archival Strategy	Primary and Secondary research
2	Opinion Strategy	Interviews
3	Empirical Strategy	Direct Observation
4	Analytical Strategy	Process Modeling Activity Based Costing Software

Table 3-1. Research Methodology

Source: Buckley, 1976

#### A. ARCHIVAL STRATEGY

Primary and secondary research was conducted using the archival strategy. Primary research consists of "original documents or official files and records" and secondary sources are "publications of data gathered by other investigators." (Buckley, 1976, Murdick, 1969). A search of current literature on accounting and Activity Based Costing in academic journals and practitioner magazines was conducted.

The author also reviewed related initiatives in government finance and accounting including Unit Costing and the Defense Business Operations Fund (DBOF). These two broad subjects have been applied to and partially implemented in DoD support organizations since the late 1980's. The intent of both DBOF and Unit Costing is to identify the true cost of doing business, and to charge the customer for the full cost of providing a service. A customer/provider relationship is needed to use either DBOF or Unit Costing. Results on the implementation of these initiatives within DoD have been

mixed. One report was found that identifies some successes and problems (Defense Business Operations Fund Improvement Plan, September 24, 1993).

Much has been written concerning manufacturing companies doing activity analyses (e.g., Cooper and Kaplan, et al., 1992; Cooper, 1990; O'Guin, 1990; Romano, 1990). In a recent work, Kaplan, et al., (1992) examined eight sites where Activity Based Costing studies had begun. Only three of these were nonmanufacturing organizations. Cooper recently conducted a field study of twenty Japanese firms. All of the companies were manufacturing entities (Cooper, 1994). Less attention has been focused on service companies (Rotch, 1990). The author's search of the literature did not identify any published materials on the subject of activity analysis in academic settings.

## **B. OPINION STRATEGY**

Interviews were conducted as part of the opinion strategy. In order to gather information on the processes within the Mechanical Engineering department, the author conducted interviews with individuals holding various positions within the department.

The interviews were unstructured. The author usually began them with the question, "what activities do you perform on a regular basis?" The next question was generally "who or what causes you to do the activities you are currently doing?" The interviewees tended to answer questions in terms of the traditional budgeting categories at the Naval Postgraduate School of the Operating Target (OPTAR), which is O&M,N funds, and Reimbursable funds. However, as the interviewee began to understand the activity point of view as explained by the author, the data they provided became relevant to the Activity Based Costing model.

The data each person provided was key to understanding the activities, the relationships among the activities that constitute each process in the department, and the amounts of activities that occur in order to produce the outputs. These individuals, considered the holders of the knowledge base in the Mechanical Engineering department, knew "inside information" about the drivers of activities and why processes flow as they do. The interview data provided subjective (Buckley, 1976) descriptions of processes. When conflicts arose in the descriptions of processes, the department Chairman's opinion was used as the process description for the model.

The following is a list of the people interviewed or who provided data to the author.

- Joseph Barron, Director of Academic Planning at the Naval Postgraduate School.
- Evelyn M. Bartolini, travel technician in the Mechanical Engineering department.
- Pam Davis, Naval Engineering education technician.
- Michelle F. Hutchins, clerk typist and travel technician in the Mechanical Engineering department.
- Robert Jay, Comptroller of the Naval Postgraduate School.
- Judy Joyce, staff assistant in the Office of Academic Planning at the Naval Postgraduate School.
- CDR Louis G. Kalmar, USN, Military Instructor at the Naval Postgraduate School.
- Matthew D. Kelleher, Professor and Chairman of the Mechanical Engineering department.
- Glendo L. Kerol, Supply Technician in the Mechanical Engineering department.

- Danielle Kuska, Research Programs Supervisor in the office of the Dean of Research.
- Thomas H. McCord, Professional Engineer and Laboratory Manager in the Mechanical Engineering department.
- Alan G. McGuire, Engineer in the Public Works department at the Naval Postgraduate School.
- Terry R. McNelley, Professor of Mechanical Engineering and Associate Chairman for Operations in the Mechanical Engineering department.
- Kathi Moore, Director of Fiscal Operations at the Naval Postgraduate School.
- LCDR Michael Murdter, USN, Public Works Officer at the Naval Postgraduate School.

### **C. EMPIRICAL STRATEGY**

Direct observation of individuals at work and the department's processes are two ways to gather empirical data (Buckley, 1976). The researcher then records, summarizes, and reports on the department's processes and activities. The author observed a limited amount of activities and processes within the Mechanical Engineering department. Some of the operational data and all of the cost data was obtained from original databases and spreadsheets maintained by the Naval Postgraduate School in the offices of the Comptroller, Academic Planning, and Dean of Research. The remainder of the operational data was derived from interviews.

### **D. ANALYTICAL STRATEGY**

For this research project, the analytical strategy functioned as the essential element used to design and develop the Activity Based Costing model for the Mechanical Engineering department. Using both inductive and deductive reasoning, the author modeled the processes, and operational and

financial flows of the Mechanical Engineering department. These flows were captured as outputs, then traced to activities, and finally to the resources. A schematic diagram was created to depict these flows.

The second part of the analytical research strategy involved building the model into a flexible activity-based costing software program. Building the model with the software required further analysis of interrelationships in each of the processes within the department. Identification of each level of the model was crucial for the flows to work properly. Within each level, proper identification of outputs, activities, and resources and description of suitable measures for each was essential. Verification of the model showed that it captured the processes in the Mechanical Engineering department.



## **IV. THE ACTIVITY BASED COSTING ANALYSIS AND MODEL FOR THE MECHANICAL ENGINEERING DEPARTMENT**

### **A. INTRODUCTION**

This chapter discusses the Activity Based Costing model that was developed using activity analysis to map the Naval Postgraduate School Mechanical Engineering department's operational and financial flows. A six step analysis is presented. The model is presented and its underlying assumptions are explained. Next, the model is validated using an activity software package. Lastly, Fiscal Year 1994 output costs are shown.

The Activity Based Costing analysis conducted for this thesis consisted of six steps:

- Identify Outputs (Step One)
- Identify Activities (Step Two)
- Identify Resources (Step Three)
- Link outputs to activities to resources (Step Four)
- Determine operational and financial flows (Step Five)
- Input all data into an activity software package (Step Six)

The six steps are presented as a linear process. In reality, the analysis was iterative and reflexive. As the research progressed, the processes became more sharply defined from bottom to top and in terms of the units of measure. Figure 4-1 is a schematic of the model.

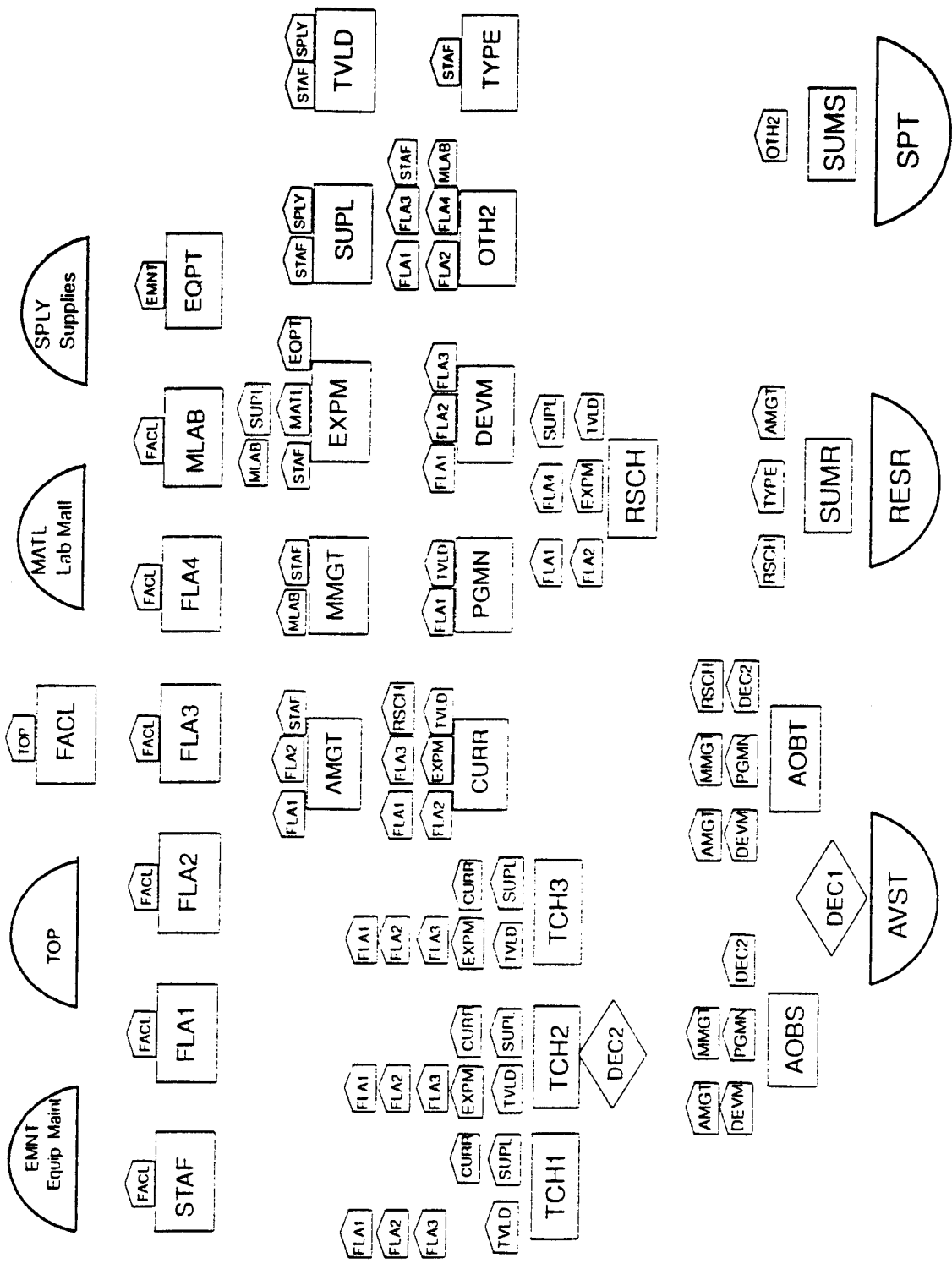

Figure 4-1. ABC Model Schematic for the Mechanical Engineering Department

Listed below are the name and description of each output, activity, and resource in the Mechanical Engineering Activity Based Costing schematic (Figure 4-1). Links between outputs, activities and resources are depicted by the shape of a house. They replace lines to reduce clutter. The shapes in the schematic and its style are derived from the Activity Based Costing software package, NetProphet II, which is described later in this chapter.

<u>NAME</u>	<u>DESCRIPTION</u>
-------------	--------------------

*Demand Boxes (Outputs): half-circles facing up*

AVST	Average On Board Students
RESR	Research Products
SPT	Support: nonvalue

*Route Boxes (Policies): diamond shaped*

DEC1	How many Students versus Thesis Students
DEC2	How many workyears per class type

*Process Boxes (including Activities): rectangular*

AOBS	Students-Average On Board (Refresher and 1st-7th quarter students)
AOBT	Thesis Students-Average On Board (8th-9th quarter students)
SUMR	Summary for Research Outputs
SUMS	Summary for Support Outputs
AMGT	Administrative Department Management
CURR	Maintaining Professional Currency
DEVM	Course and Program Development
EXPM	Laboratory Experiments

<b>MMGT</b>	<b>Naval Engineering Curricular Management</b>
<b>OTH2</b>	<b>Other Nonvalue Added</b>
<b>PGMN</b>	<b>Academic Program Maintenance</b>
<b>RSCH</b>	<b>Research</b>
<b>SUPL</b>	<b>Handling Purchase Orders and Supplies</b>
<b>TCH1</b>	<b>Teaching Lecture classes</b>
<b>TCH2</b>	<b>Teaching Design classes</b>
<b>TCH3</b>	<b>Teaching Laboratory classes</b>
<b>TVLD</b>	<b>Handling Travel Orders and Claims</b>
<b>TYPE</b>	<b>Editorial Assistance and Research Proposal Preparation</b>

*Process Boxes (Fixed Resources): rectangular*

<b>EQPT</b>	<b>Equipment for Laboratories and Experiments</b>
<b>FACL</b>	<b>Utility and long-distance telephone usage in Facilities</b>
<b>FLA1</b>	<b>Faculty Labor (Tenure-track): Teach Two/Research Two Quarters</b>
<b>FLA2</b>	<b>Faculty Labor (Tenure-track): Teach One/Research Three Quarters</b>
<b>FLA3</b>	<b>Faculty Labor (Adjunct): Teach Four of Four Quarters</b>
<b>FLA4</b>	<b>Faculty Labor (Adjunct): Research Four of Four Quarters</b>
<b>MLAB</b>	<b>Military Labor (Active duty)</b>
<b>STAF</b>	<b>Staff Labor</b>

*Variable Resource Boxes: half circles facing down*

<b>EMNT</b>	<b>Equipment/Computer Maintenance</b>
<b>MATL</b>	<b>Laboratory Materials</b>
<b>SPLY</b>	<b>Supplies for entire department</b>
<b>TOP</b>	<b>Top of the model to function as an entry link</b>

## **B. IDENTIFY OUTPUTS (STEP ONE)**

For this thesis, research was focused on the department's outputs. The three outputs identified as produced by the Mechanical Engineering department are graduates, research products, and support outputs. Once the outputs were defined, the analysis moved to the activities and resources.

## **C. IDENTIFY ACTIVITIES (STEP TWO)**

Starting with the three outputs that have been defined as graduates, research products, and support outputs, activities were identified that take place in order to produce those outputs. Some activities were immediately obvious e.g., teaching and research, while other activities were harder to define and quantify e.g., handling travel orders/claims (transportation assistant) and handling purchase orders and supplies (supply technician).

The level of definition within each activity was determined by its usefulness to the department managers. Some activities contain many sub-processes that are too detailed to be tracked and reported on within the model. The supply technician handles purchase orders and supplies, for example, maintains spending records and budgets, and also files various documents. These sub-activities consumed less time overall than the major activity of handling purchase orders and supplies, thus the major activity defined and provided the unit of measure for the supply activity within the department. Consideration of the costs involved in gathering, defining, and modeling the subprocesses was also a factor in not including the subprocesses.

A total of fourteen activities were identified and defined within the model (see Figure 4-1). Implicit in those fourteen is the recognition that they are aggregates of activities or processes. Next, the resources which are demanded by the activities were identified.

#### **D. IDENTIFY RESOURCES (STEP THREE)**

The top of the processes within the Mechanical Engineering department contain the fixed and variable resources. Each activity requires one or more resources (see Figure 4-1). A total of eight fixed resources and four variable resources were identified. Resources were defined as fixed or variable based on how they generally are considered e.g., labor is basically fixed in the short term whereas department supplies are basically variable in the short term.

The most readily identifiable resource was labor: faculty, staff, and military. Less clear was the definition of the facilities resources and the utilities needed to operate the facilities. For the model, the physical buildings were considered to already exist; no costs of construction or depreciation expense were included. Building maintenance and utility usage, both overhead allocations, were included in the model. Long distance telephone usage was included.

#### **E. LINK OUTPUTS TO ACTIVITIES TO RESOURCES (STEP FOUR)**

The fourth step included linking all the outputs to activities and each of the activities to resources. Outputs (requirements for activities) were linked together with the activities in this step. Identification of links between activities and resources and activities higher up in the model was done after the establishment of links at the bottom of the model.

Relationships between each output activity and resource were initially identified at this point. These relationships were the key to determining the

quantities (operational and financial) which flow through each process. Some of these relationships were unclear and the department Chairman's opinion was used where differences of opinion over the exact relationships existed. Fully linked, the model became workable allowing both operational and financial flows to be calculated.

#### **F. DETERMINE OPERATIONAL AND FINANCIAL FLOWS (STEP FIVE)**

Once the outputs, activities, and resources were clearly identified and defined with measures understandable to the department Chairman, and each level was properly linked together, the fifth step began. In this step, the amount of each activity that was performed in relation to each output was determined, and the cost associated with that amount of activity was computed. Adjustment of the relationships between outputs and activities, and activities and resources initially established in step four was conducted at this step.

The average number of students on board was used to reduce complexity in the model. This measure was proposed by the department Chairman as a reasonable measurement of how many students were in the department, on average, on any day in the year. Students were further defined to be in the refresher or first seven quarters of the curriculum, or in the eighth and ninth quarters and were designated Students-Average On Board and Thesis Students-Average On Board, respectively.

These two distinct but similar measures allow the model to calculate the different activities demanded by students in the early and later stages of the curriculum. The costs of the two student types vary as the activities demanded vary in cost. Instruction, for example, is demanded in batches and not in units, whereas research is required both individually and in batches.

Operational and financial flows were determined based on Fiscal Year 1994 data. The model uses Fiscal Year 1994 as a baseline.

#### **G. INPUT ALL DATA INTO AN ACTIVITY SOFTWARE PACKAGE (STEP SIX)**

Step six involved inputting all the model data into an activity based costing/management software package. Up to this point, the model was simply a static representation of the Mechanical Engineering department. It showed a one-time view and was fixed in time and place. However, the software provides for changes.

#### **H. ACTIVITY BASED COSTING MODEL**

##### **1. Outputs**

The Mechanical Engineering Department produces three outputs: graduates, research products, and support outputs, as previously mentioned. Table 4-1 below lists the three outputs.

a.	Graduates
b.	Research Products
c.	Support Outputs

Table 4-1. Department Outputs

##### ***a. Graduates***

Graduating students with a masters degree in Mechanical Engineering is the primary focus for the Mechanical Engineering department. Of the 100 students in the Mechanical Engineering department, an average of 12 students graduate each academic quarter, or a total of forty-eight every academic year (Davis, 1994). Subtracting the twelve graduates leaves eighty-eight students at any time. Students are considered to be in the refresher or first through the seventh quarters of the nine quarter

Mechanical Engineering program (76 students) while thesis students are considered to be in the eighth or ninth quarters of the program (24 students) (Kelleher, 1994).

Tracking students in two different categories allows the identification and association of costs of differing activities and resources. Thesis students require research time from the faculty, and less instruction time. Students are just the reverse. As previously mentioned, the requirement for some activities is not a linear function; activities such as teaching is needed in batches.

The Average On Board measure allows the use of this cost function but requires the assumption of a steady-state model. Thus, each student moving to the eighth quarter (thesis student) was assumed to be replaced by a student and each thesis student leaving the Mechanical Engineering department (graduate) was assumed to be replaced by another thesis student. This allows modelling of the average on board strength in Fiscal Year 1994 of one hundred students (Kelleher, 1994). If the Mechanical Engineering program was exactly one year in length, the average on board measure would not be needed.

***b. Research Products***

Research products are the second output of the Mechanical Engineering department. Tenure track faculty members are expected to conduct research in their specialty (Kelleher, 1994). Most research is documented in some form and usually published. This published report may include answers to questions from the customer, results of experiments, or other findings.

An integral part of faculty research is student research (Kelleher, 1994). Without faculty research projects students would have a more difficult experience conducting research (Kelleher, 1994). Tenure track faculty members are expected to attract research projects to the department

(Kelleher, 1994). Thus, faculty and student research are closely linked. To model this, only one research output and one research activity was included. The activity of research represents the closely-linked faculty and student research, although the measure for this activity is faculty workyears.

Graduates are considered an output and not an input. No student labor resources or activities are tracked; thus to measure student research as an output would not be logical.

Forty-eight research products resulted from faculty and student research and other activities conducted in the Mechanical Engineering department in Fiscal Year 1994 (Kelleher, 1994). The number of research outputs almost directly corresponds with the total number of graduates in Fiscal Year 1994. According to the department Chairman, each student thesis contributes to a research product or deliverable to a customer.

***c. Support Outputs***

The third Mechanical Engineering department output, support, is the result of any activity which does not productively contribute to the department's two primary outputs. Data calls for the BRAC, or routine paperwork tasks needing to be redone to fulfill government requirements are two examples of such activity.

Support outputs are shown as a separate output in the Activity Based Costing model because the activities which result in support outputs do not contribute in a measurable way to producing graduates or research products. In order to measure the cost of answering requirements generated from above or outside the Naval Postgraduate School, the operational flows and costs of those activities must be accumulated separately from the two primary outputs.

An estimated ten percent of each average faculty, staff, and military workyear was needed to fulfill the activities which produced support outputs (Kelleher, 1994). The measure of workyears was used for support

outputs and measures the total faculty, staff, and military workyears devoted to support outputs.

## **2. Activities**

This section provides the rationale for the factors and links constituting the relationships between activities and other activities and resources. The department's activities are listed and some examples are discussed.

The fourteen activities in the Mechanical Engineering department are represented in the Activity Based Costing model (see Figure 4-1). Properly identifying and classifying the work that was accomplished by the faculty and staff was critical. Multiple interviews with the faculty and staff were needed to comprehend in detail the interrelationships in the Mechanical Engineering department and the Naval Engineering curriculum. The distinction between each level of activity is not always clear in the Mechanical Engineering department. Some activities fit into two or more levels. An example is research; student and faculty research are considered inseparable (Kelleher, 1994). Research, as an activity, is demanded by batches of students who are advised by the faculty and by individual customers who reimburse the faculty for costs incurred in producing research outputs or deliverables.

For modeling purposes, the activity of research, in the above example, is defined in terms of faculty workyears. Using this common measure, all demands for faculty research were measured or estimated. The relationships between student demand, reimbursable customer demand and the research activity were then input into the model. For modeling purposes, the supply department activity is measured in staff workyears and demand relationships are set accordingly. Table 4-2 lists all fourteen activities.

a.	Teaching Lecture classes
b.	Teaching Design classes
c.	Teaching Laboratory classes
d.	Research
e.	Experiments
f.	Administrative Department Management
g.	Naval Engineering Curricular Management
h.	Other Nonvalue Added
i.	Editorial Assistance
j.	Maintaining Faculty Currency
k.	Program Maintenance
l.	Course and Program Development
m.	Handling Purchase Orders/Supplies
n.	Handling Travel Orders/Claims

Table 4-2. Department Activities

***a. Teaching Classes (Lecture, Design, Laboratory)***

Teaching is conducted by the tenure track and non-tenure track faculty. Teaching in this context is defined as imparting skill or knowledge of a subject to an individual. For the Activity Based Costing model, the activity of teaching includes everything the faculty member does related to instruction, e.g., out-of-class preparation time, in-class instruction, and scheduled office hours.

Faculty members normally teach two four-hour classes per quarter, although in the Mechanical Engineering department some faculty teach only one class per quarter, while others may teach an equivalent of three classes per quarter because of extra laboratory or class sections.

These extra sections are sometimes necessitated by a limited number of workstations or other equipment (McNelley, 1994). A full load is considered eight courses per calendar year, which equals the two courses taught per quarter times four quarters (Kelleher, 1994). The tenure-track faculty are expected to support themselves from reimbursable projects when they are not scheduled to teach (Kelleher, 1994).

In order to properly model the need generated by students for teaching, a step function was used. The use of a special policy in the model governing the teaching activity accomplishes the step function. One faculty member usually teaches a class section of anywhere from five to thirty students. Thus, class sections are required by batches of students, not individual students.

The special policy draws faculty workyears as required into three separate teaching activities: lecture, design, and laboratory classes. Faculty workyears are used to teach all the lecture classes, then all the design classes, and then all the laboratory classes. Thus, with a known quantity of classes by type to be taught in any given year, the required faculty teaching workyears are determined. Additional faculty members can be hired to teach the classes that will not be taught by the resident faculty.

One artificiality introduced by the limitations of the software version used is the distribution of the types of classes taught by each faculty labor pool. The model shows each of the three teaching faculty labor pools (Adjunct Research faculty do not teach as a general rule) teaching lecture, design, and laboratory classes in the same proportion to the amount of total labor available in each of these labor pools. This is not always the distribution of teaching in the Mechanical Engineering department. The limitation can be overcome by modeling one labor pool per faculty member.

***b. Research***

Research is conducted by both faculty and students. The activity of research is integral to the academic process and is required for both the tenure track faculty (SECNAVINST 1524.2A) and the students (1994 Naval Postgraduate School catalog).

Research is defined as a diligent and systematic inquiry into a subject in order to discover or revise facts or theories. This activity usually leads to a research product for a customer. Some research is conducted on a reimbursable basis and some on a direct funded basis as part of the Naval Postgraduate School budget.

As previously mentioned, the Mechanical Engineering department Chairman views research conducted by students and faculty as inseparable, thus the model shows Thesis Students-Average On Board (an output) requiring a portion of the activity of research which in turn requires faculty workyears. In contrast, Students-Average On Board (an output) do not require any research activity according to this distinction. No student resources or activities are tracked in the model. Graduates are considered an output, not an input.

***c. Experiments***

In the Mechanical Engineering department, experiments are vital to teaching and research. Experiments in laboratories and in computer simulations are a regular part of the graduate education in the Mechanical Engineering department. Lower and upper division classes may require physical mockups for experiments in various laboratories. Students in approximately ten percent of the Mechanical Engineering department classes must participate in these experiments because they are considered integral to the instruction (Kelleher, 1994).

Student thesis research is also carried out with experiments. Approximately half of the students conduct thesis-related experiments with physical mockups or models (Kelleher, 1994). The other half of the thesis students use computer simulations for their thesis and do not require a physical model (Kelleher, 1994).

Experiments drive a need for laboratories, laboratory equipment, materials that are consumed in the course of experiments, and staff labor to assist in the conduct of the experiments. Maintenance contracts are purchased periodically from various sources for the upkeep of the laboratory equipment and the computers that monitor the test equipment.

***d. Administrative Management***

Administrative management of the academic department is performed by three faculty members. They include the department chairman, the Associate Chairman for Operations, and the Academic Associate. They are assisted by an Administrative Support Assistant. The total work for this activity in Fiscal Year 1994 was two workyears; one workyear for the three faculty members combined and one workyear for the administrative support assistant.

A total of one workyear within the O&M,N (direct teach) budget in the Mechanical Engineering department was paid to the three faculty members for performing administrative duties. The chairman decides what fraction of the one workyear is paid to the other two faculty members.

The relationship between the activity of administrative department management and outputs is fixed or constant in the sense that a few more students or a few more research products do not require another chairman or another administrative support assistant. Thus the work flow calculated by the model for this activity equals exactly two workyears.

***e. Naval Engineering Curricular Management***

Naval Engineering Curricular management, is similar to the activity of administrative department management, and records the work of the individuals in the Naval Engineering curricular office (Code 34). The curricular officer is a Commander in the United States Navy. In Fiscal Year 1994, he was assisted by one staff member, an education technician, who worked full-time for the curricular office.

The work performed by both individuals benefits the entire Naval Engineering department. Only one curricular officer is required for the program. An increase or decrease in the number of students in the department is not likely to change the requirement, in the short term, for one education technician. The relationship between Students-Average On Board and Thesis Students-Average On Board and curricular management is fixed. Thus, the model calculated the workload in this activity at a constant factor for a total of two workyears.

***f. All Other Activities***

Relationships between all other department activities and outputs produced and the resources required are similar to the examples discussed above. Maintaining faculty currency, program maintenance, course and program development are performed by various faculty members. The time required for these activities is relatively small compared to teaching and research.

The department's staff members handle purchase orders/supplies and travel orders/claims. Various staff members are assigned to the supply and travel functional areas within the department to perform these primary duties. Editorial assistance is also provided by the staff as needed. Other nonvalue added activities consume ten percent of each faculty, staff, and military member's workyear, as previously discussed.

### 3. Resources

Resources are the top level of the Activity Based Costing model (see Figure 4-1). Eight resources are fixed and four are variable. Regular (not overtime) staff labor is one of the best examples of a fixed resource because it is nearly fixed within a year. Department supplies and laboratory materials are good examples of variable resources which are demanded as needed. This section lists the department's resources, and discusses some examples. Table 4-3 lists all the resources used by the Mechanical Engineering department, and included in the Activity Based Costing model.

VARIABLE RESOURCES	FIXED RESOURCES
Equipment Maintenance	Staff Labor
Top of the model	Faculty: Teach 2/Research 2 Quarters
Laboratory Materials	Faculty: Teach 1/Research 3 Quarters
Department Supplies	Faculty: Adjunct Teach 4 Quarters
N/A	Faculty: Adjunct Research 4 Quarters
N/A	Military Labor
N/A	Equipment
N/A	Facilities

Table 4-3. Department Resources

No student labor resource pool is included in the model. This means that student activities and associated costs are not tracked. The main reason for this is that graduates are considered to be a department output, not an input or resource to produce the output (Kelleher, 1994).

#### *a. Faculty Labor*

Faculty labor represents the costliest resource in the Mechanical Engineering department included in the model. Not all faculty members are a part of the department for a complete year. Using a full-time equivalent

measure reduces complexity in the model and is fairly representative of the labor used in the year. A total of twenty-one (20.99) full-time equivalent Mechanical Engineering faculty members were paid in Fiscal Year 1994 (Barron, 1994). The salaries of individual faculty members are considered sensitive information (not classified) and were not released to the author. The author used average salaries for the model.

The faculty were grouped into four pools in order to model faculty activities and costs without knowing individual salaries. Labor groupings by activity type, as suggested by the department Chairman, were used in the model. Group one consists of tenure-track faculty teaching two quarters and researching two quarters. Group two consists of tenure-track faculty teaching one quarter and researching three quarters. Group three consists of adjunct faculty teaching four quarters. Group four consists of adjunct faculty researching four quarters.

Eleven tenure-track faculty, who teach two quarters and research two quarters, are represented by group one. Four tenure-track faculty members are in the second group. They primarily teach one quarter and research three quarters. Most tenure-track faculty are expected to teach two quarters, and research the other two quarters (Kelleher, 1994).

The third faculty labor pool represents three Adjunct teaching faculty. The Adjunct teaching faculty's primary duties include teaching full-time which is eight courses per year (Kelleher, 1994). The fourth pool represents three Adjunct research faculty members. Their primary duties include full-time research four quarters per year, and teaching no more than one class per year (Kelleher, 1994).

All four labor pools represent full-time equivalent workyears that total to twenty-one for Fiscal Year 1994. Activities performed by the faculty draw resources in terms of workyears from the four labor pools. Each activity draws resources in proportion to the type of faculty labor required for the activity.

***b. Staff Labor***

Staff labor is the second costliest resource in the Mechanical Engineering department. A total of 13.49 full-time equivalent staff members were paid during Fiscal Year 1994 (Barron, 1994).

The staff perform activities such as assisting with experiments, handling travel orders/claims or purchase orders, and editorial assistance. Additionally, one staff member in the Mechanical Engineering department office assists the Chairman with administrative management, and one staff member in the curricular office assists the Curricular Officer with curricular management. They were described previously in the activity section. Machinists and model makers prepare the physical mockups which are used for experiments in the laboratories. Other staff members supervise the setup and conduct of the experiments, and assist students and faculty in monitoring the experiments.

***c. Military Labor***

The curricular officer for the Naval Engineering curricular office (Code 34), a Commander in the United States Navy, and a Petty Officer, First Class in the United States Navy, are part of the labor resources which contribute to the production of the Mechanical Engineering department outputs. These two active duty personnel are paid from the Military Personnel, Navy (MP,N) account, not from the Naval Postgraduate School budget (Kalmar, 1994; Kelleher, 1994). However, their work and the costs of their salaries and benefits must be included in the operational flows and costs of the department outputs. The Activity Based Costing model includes

these flows by designating a military labor pool and by using the most recent composite rates of the active duty members' salaries and benefits as calculated by the Comptroller of the Navy (NAVCOMPT Notice 7041, 1992).

#### **4. Modeling Software Package Description**

An off-the-shelf software package was installed on a personal computer (PC) in the Mechanical Engineering department to graphically demonstrate the capabilities of the Activity Based Costing model. The model operates using a modeling software package called NetProphet II, by Sapling Corporation. It is designed to model, using an activity perspective, the processes, activities, and policies which constitute the operational and financial flows of an organization. No intent was made to replace or invalidate the Navy's current accounting systems; instead, the Activity Based Costing model runs on a PC complementing the current system. Validation of the model was accomplished using the software which allowed numerous options and provided flexibility.

The software release used to build the flexible model for this thesis is an academic version 02.EN.2h. The academic release has certain limitations, one of which is that a maximum number of forty variables, called boxes, may be designed into a model. The number of boxes is significant because each output, activity, and resource is represented by boxes. This restricts the complexity and thus the accuracy of the Mechanical Engineering department model.

If the commercial version of the software package were used, each faculty, staff, and military member could be represented by a separate labor pool to ensure the most accurate flow and tracking of resources. Activities such as teaching could also be represented more accurately with the commercial version. For example, each course could be shown separately. In the same manner, aggregated activities such as handling travel

orders/claims and purchase orders could be broken down into separate activities.

## **5. Model Software Information**

The software model contains information that includes time periods, units, cost categories, multipliers, tags, capacities, and relationships (links and factors). See Appendix A for a graphical depiction of each output, activity, and resource. See Appendices B through E for all model software information.

In order to use the software, a time period must be chosen to create a baseline and validate the model with known operational and financial flows from that year. As stated previously, Fiscal Year 1994 was selected as the baseline year for operational and financial data because it was the most recent fiscal year.

### ***a. Time Periods***

Time periods are related to the units for each output, activity and resource. The academic version used for the Activity Based Costing model is limited to four time periods. For ease of understanding, and to be the most useful to the Mechanical Engineering department managers, the time period used in the model is years. This parallels the Naval Postgraduate School resource budget periods. Flows were calculated for one year, which is the first period in the model.

Another meaningful time period within the Mechanical Engineering department is the entire curriculum length of approximately 29 months. This figure denotes the average length of time students have taken recently to complete the program (Kelleher, 1994). The modeling software does not tabulate costs for the cumulative period of 29 months. However, the financial data can be exported to a spreadsheet program, such as Lotus 1-2-3 or Excel, cumulative costs calculated and graphic representations

created, and then the user can import the data into NetProphet II (NetProphet II User Guide, 1994).

***b. Units***

Units are the measurements of the outputs, activities, and resources in the Activity Based Costing model. Measures were chosen for their common sense appeal and for their standard usage throughout the department and the Naval Postgraduate School.

The unit already in use at the Naval Postgraduate School for academic labor planning (workyear) is the standard unit for labor resources and activities in the Activity Based Costing model. In the model, faculty work is measured by outputs e.g., classes taught or research products delivered, whereas staff and military work are measured as inputs e.g., hours worked in a year. The Students-Average On Board and Thesis Students-Average On Board are measured by the unit of Average On Board Students. All of the units used in the model are listed in Table 4-4.

a.	Average On Board Students
b.	Research Products
c.	Supply-Purchase Orders
d.	Travel Orders/Claims
e.	Experiments
f.	Equipment
g.	Contracts
h.	Units
i.	Utility/telephone usage
j.	Proposals
k.	Faculty Workyears
l.	Staff Workyears
m.	Military Workyears
n.	Workyears
o.	Materials

Table 4-4. **Model Units**

***c. Cost Categories***

The cost categories are essentially the general ledger for the Mechanical Engineering department. Cost categories were chosen by their current Navy accounting system usage at the Naval Postgraduate School of labor, travel, and Operating Target (OPTAR). Some of the categories were funded from more than one funding source. Reimbursable research and direct funded research both fund labor, travel, and other costs. Other cost categories were added to the model to accumulate costs of each resource, activity and output. See Appendix B for a complete listing of these cost categories.

The Activity Based Costing model software tracks costs at each level of the model. Costs of outputs, activities, and resources accumulate to cost categories at each respective level in the model. Variable costs accumulate according to the amount of the variable resources required. Costs of the fixed resources are charged regardless of the amount required.

***d. Multipliers***

Multipliers in the Activity Based Costing model software allow for easy flow changes when "playing 'what if' scenarios." "Playing 'what if' scenarios" is the term used by the software company to describe increases or decreases in output, activity, or resource flows. Anything in the model may be changed to "play a 'what if' scenario," allowing the user to "envision and try out a variety of strategies" (NetProphet II User Guide, 1994).

Increasing or decreasing the flows through one or more outputs is accomplished by using one of the multipliers. Using a multiplier will cause the entire model's flows to change when the model is recalculated. Or a multiplier can be used with a resource, for example, to simulate an increase in faculty or staff labor. Likewise, a multiplier associated with an activity changes the amount of that activity needed to accomplish another activity or output linked to it.

***e. Tags***

Tags are used in the Activity Based Costing model to identify levels of activities and nonvalue added activity. Unit (U), Batch (B), Product (P), and Facility (F) activities have been tagged in the Activity Based Costing model. A nonvalue added tag (N) was added for the nonvalue added activity within the Mechanical Engineering department. Appendix D contains a listing of all tags.

### ***f. Capacities***

The capacity constraint on certain activities and resources indicates the maximum available capacity for that activity or resource. After calculation, the model visually indicates a constraint has been broken if any capacity has been exceeded. For example, if more teaching workyears were required from the lecture teaching activity than is available, a broken capacity constraint symbol is shown.

### ***g. Relationships***

The operational flows through an Activity Based Costing model are driven by the relationships between outputs, activities, and resources at each level of the model. The relationships are modeled using links and factors. The links and factors for the Mechanical Engineering department model were derived from information gained during the interview portion of the research with faculty and staff. This information is therefore open to question.

The objective of this thesis was to develop an Activity Based Costing system for an academic department. That required choosing a source of policy and information in the case of conflicts. The author envisioned the Chairman of the Mechanical Engineering department as the chief user of this model and thus the decision maker. Therefore, the information gained from interviews with the Chairman determined most of the relationships (links and factors) at each level of the model. Some of the relationships are based on a compilation of interviews of other faculty and staff to round out information not obtained from the Chairman.

## **I. MODEL VALIDATION**

The Activity Based Costing model developed in this thesis has been validated with the data obtained by the author and with the department Chairman. The Mechanical Engineering department Chairman assisted in the

definition of the outputs, activities, and resource groupings of the model. He provided the basic policies and activity requirements which constitute the relationships that drive the operational and financial flows in the model.

Validation of the model was done in stages. The logic of the relationships within the processes was verified with the department Chairman. Validation of the model was also accomplished using NetProphet II, an activity based costing/management software package. After all the relationships were built into the model (Step four of the analysis) and all the data was entered into the software (Step six of the analysis), and the flows calculated by the modeling software were compared and adjusted to Fiscal Year 1994 actual flows, the results were presented to the Chairman of the Mechanical Engineering department.

A steady-state was assumed for Fiscal Year 1994 and the model, as previously mentioned. Thus, each student moving to the eighth quarter (thesis student) was assumed to be replaced by a student and each thesis student leaving the Mechanical Engineering department (graduate) was assumed to be replaced by another thesis student. Future refinement of the department's Activity Based Costing model is recommended to adjust for any nonstandard operational or financial flows that may have occurred in Fiscal Year 1994.

Workyear flows in the model reflect the actual workyears executed and paid for in Fiscal Year 1994. For Fiscal Year 1994, the model shows that 11.28 workyears of teaching in Mechanical Engineering were demanded by the Students-Average On Board and Thesis Students-Average On Board. This is within one workyear of the actual (executed) workyears of 12.15. The variation between the model and actual results from limitations of the academic software version, primarily the forty variable maximum.

Staff and military labor workyear flows in the model reflect the actual (executed) workyears from Fiscal Year 1994. The model shows 14.27

workyears for staff labor (13.49 actual) and 2.0 workyears for military workyears (2.0 actual) were required. All other flows through the model were validated against known flows, or where no flow data was available, against a summation of the interview data. Appendices F and G provide detailed flow information from calculations made by the model.

The department Chairman was briefed twice on the results of the model. Relationships between outputs, activities, and resources were verified; operational and financial flows were reviewed and verified and output costs were presented. The Activity Based Costing model represents the outputs, activities, and resources of the Mechanical Engineering department, with limitations that were previously discussed.

#### **J. OUTPUT COSTS FOR FISCAL YEAR 1994**

Activity Based costs were determined by the operational flows required by the three outputs. Unit cost is found by dividing the total cost of an output, activity, or resource by the number of units (its unique measure) which flow through that output, activity or resource. Unit and total costs calculated by the model can be useful to management for decision making and budgeting. Unit costs for an Average On Board Student and for a Research Product, and the total cost for Support Outputs are among the most useful. The total and unit costs for each output, where applicable, are listed in Table 4-5.

	Students	Thesis Students	Research Products	Support Outputs	TOTAL COST
Units	88	12	48		
Unit Costs	\$17,712	\$42,647	\$25,575		
Costs	\$1,558,629	\$511,758	\$1,227,620	\$304,252	
Total Units	100				
Unit Cost	\$20,704				
TOTAL COSTS	\$2,070,387		\$1,227,620	\$304,252	\$3,602,559

**Table 4-5. Output Costs**

**1. Graduates**

The average on board student, as previously mentioned, was chosen as the surrogate measure of the Mechanical Engineering department's graduate output in any year. Students require approximately twenty-nine months of refresher, regular instruction, and research to complete the Mechanical Engineering masters degree (Kelleher, 1994). The average on board measure takes the average of students and thesis students to describe the average on board student (output) within a year. The Average On Board for Fiscal Year 1994 was one hundred students (Davis, 1994; Kelleher, 1994).

The Fiscal Year 1994 annual unit cost for the Average On Board student in the Mechanical Engineering department was \$20,704. This cost should be construed as an estimate within a range, not an exact number. The Activity Based Costing model consistently showed that the annual cost exists within a range of \$20,000 to \$25,000. Note that this cost does not include costs such as facilities construction, library usage, or school administration. The Fiscal Year 1994 annual unit cost for Students-Average On Board was \$17,712. The Fiscal Year 1994 annual unit cost for Thesis

Students-Average On Board was \$42,647. Appendix F details the total and unit cost per output. Appendix H provides the total cost information for the department, and Appendix I shows the total costs per cost category. No probabilistic or statistical techniques were used to determine the cost ranges (Ferrarra and Hayya, 1970).

## **2. Research Products**

Research products, as previously defined in the Activity Based Costing model, are faculty research outputs or deliverables (Kelleher, 1994). The number of research products produced in the Mechanical Engineering department in Fiscal Year 1994 was estimated at forty-eight (Kelleher, 1994). The Mechanical Engineering faculty were paid for 8.85 research workyears (direct research and reimbursable research) in Fiscal Year 1994. The graduates produced forty-eight theses in Fiscal Year 1994.

Using the estimate of forty-eight research products, the Fiscal Year 1994 cost per research product was \$25,575. Note again that this cost does not include costs such as facilities construction, library usage, or school administration. This cost should be considered within a range. The Activity Based Costing model consistently showed that the annual cost exists within a range of \$22,000 to \$32,000.

## **3. Support Outputs**

Support outputs, as previously defined in the Activity Based Costing model, include work which does not contribute productively to the department's two primary outputs, such as rework for administrative requirements or data calls for the BRAC. Support outputs can also be considered nonvalue added work for the Mechanical Engineering department. Rework on travel orders/claims or purchase orders, and other wasted time is included in this output measure.

No records were kept on wasted time or work within the Mechanical Engineering department for Fiscal Year 1994 so an estimate (provided by the

department Chairman) was made in order to show the operational flow and associated costs. An estimate of ten percent of each average faculty, staff, and military workyear in the department was needed to fulfill the activities which produced support outputs (Kelleher, 1994). The measure of workyears was used for support outputs and measures the total faculty, staff, and military workyears devoted to support outputs.

Using this output number of 3.7 workyears, the total cost of Support outputs in the Mechanical Engineering department for Fiscal Year 1994 was \$304,251. As described earlier, this number is the total cost for Support outputs based on an estimate of work devoted to tasks other than the department's two primary outputs. Closer tracking of work that does not contribute to the two primary outputs will provide better management information in the future.

## **V. CONCLUSIONS AND RECOMMENDATIONS**

### **A. CONCLUSIONS**

The primary research question addressed in this thesis was: Can a model be developed that identifies activities which drive costs in an academic department at the Naval Postgraduate School? A model was developed in this thesis.

Additionally, two subsidiary research questions were asked. To what extent can the Activity Based Costing model be an effective tool for managers to justify resources by identifying the specific activities that drive costs in an academic department? To what extent will this Activity Based Costing model be an effective tool for budgeting by managers? The Activity Based Costing model is a reasonable means of justifying a department's use of resources and can function as a budgeting tool.

#### **1. Activity Based Costing Model Identifies Activities Which Drive Costs**

The primary research question required the development of a model to identify activities which drive costs. A model was developed for the Mechanical Engineering department at the Naval Postgraduate School to describe the department's three outputs and the process flows that take place in order to produce them.

Modeling processes using Activity Based Costing tracks operational and financial flows through a department based on what drives or causes the activity to occur. Thus, requirements for resources and activities, and the costs of each, are clearly identified. Other requirements for activities from outside the department are not depicted in the model.

## **2. Activity Based Costing Model Provides A Justification For Resource Use**

The Activity Based Costing model provides a justification for resource consumption within a department. Not only does it identify which activities cause a need for resources, but it shows relationships (links and factors) from each output up through activities to the resources. Managers may use this information to support why the department's resources are needed.

Clearly, resource justification will become more important as growth in the federal government's budget continues to shrink, and with it the DoD budget. This model will assist decision makers in answering requests for this type of resource justification.

## **3. Activity Based Costing Model May Function As A Budgeting Tool**

This Activity Based Costing model could be used as an effective tool for budgeting. By "playing 'what if' scenarios," the manager can make reasonable assumptions about decisions in advance of the actual consequences of those decisions.

# **B. RECOMMENDATIONS FOR APPLICABILITY**

## **1. Mechanical Engineering Department**

The Mechanical Engineering department should continue to track their processes using this Activity Based Costing model. Further refinement using input from the department chairman is needed. If the commercial version of the software is acquired, each activity in the current model could be broken down into its subparts thus increasing the manager's knowledge of the resource requirements. Separate labor resource pools could be added for each faculty, staff, and military member.

More accuracy could be gained from further detail of the operational and financial flows in the department. However, added complexity could slow implementation and use of the model. The tradeoff between the costs

of gathering the information and the potential benefits to be gained from greater accuracy in this model should be evaluated.

Output costs, as previously mentioned, should be read as range estimates not point estimates. The operational and financial flows calculated in the model were established on the baseline Fiscal Year 1994. Also, it must be noted that the output costs can vary significantly based on assumptions made about the relationships between outputs, activities, and resources.

## **2. Other Departments**

The most natural extension of the Activity Based Costing model created for the Mechanical Engineering department is to other academic departments at Naval Postgraduate School. The three outputs, defined as graduates, research products, and other outputs will fit most other academic departments. Further research to identify the specific activities and process flows would be needed to properly tailor this Activity Based Costing model to a new department.

Line managers at the Naval Postgraduate School could benefit from Activity Based Costing. One example is the Public Works department which provides many services for which it is reimbursed. A well-developed Activity Based Costing model could help the Public Works department determine the costs of and the appropriate charges for services provided.

## **3. Tenant Commands**

Defense Resources Management Institute and Defense Manpower Data Center are two tenant commands of the Naval Postgraduate School. They receive services and reimburse the Naval Postgraduate School for some of those services. Some of those services are billed to tenants based on allocation rates that could be inaccurate, leading to overcosting or undercosting. The potential benefits for tenant commands include identifying the amount of services they actually demand from the Naval

Postgraduate School and how much they should pay for the services received. The potential benefit to the Public Works department could include reimbursement at rates they have higher confidence in and which pays for the services rendered.

Instruction on-site at the Naval Postgraduate School and off-site, and other services produced by the Defense Resources Management Institute could be costed more accurately with a well-developed Activity Based Costing model. More accurate costs would assist billing for services provided to more closely reflect the actual costs of doing business. The same benefits are potentially available to the Defense Manpower Data Center.

#### **4. Naval Postgraduate School**

The BRAC, as mentioned earlier, looks at cost effectiveness when considering base closures. Justification of the cost of the education provided to students by the Naval Postgraduate School seems to be a recurring event. An Activity Based Costing model could provide support for the use of resources at the Naval Postgraduate School. The current model could be expanded to cover a larger part of the school.

Expansion of the model could be accomplished by starting the implementation at each academic and administrative department then integrating the parts. Building the departmental models will help provide the detailed knowledge of activities at a lower level. This is required to understand the activities on a larger scale. Education of the students, staff and faculty on activity-based modeling concepts will assist in the development of a model for the Naval Postgraduate School.

## **5. Department of the Navy Academic Institutions**

Other Department of the Navy academic institutions such as the Marine Corps University, Marine Corps Command and Staff College, and the Naval War College all could potentially benefit from the development and implementation of an Activity Based Costing model. Successes with implementation of Activity Based Costing within academic departments at the Naval Postgraduate School will help demonstrate the applicability to other similar organizations. As mentioned earlier, shrinking budgets and the requirement to provide continuing justification for educational resources provide opportunities for Activity Based Costing models. The budgeting process also opens opportunities for implementation of Activity Based Costing models.

### **C. FUTURE RESEARCH**

Continued research is needed for the Mechanical Engineering department model developed in this thesis. Definition of the subactivity groups within the currently defined activities is the area in which to begin further study. Adding one labor resource pool per faculty, staff, and military member and tracking the work of each member separately could increase the accuracy of the model. Closer tracking of nonvalue added work and requirements for support outputs in the Activity Based Costing model could identify future cost savings.

Research into another academic department at the Naval Postgraduate School should also be considered in order to develop and implement an Activity Based Costing model. The current Activity Based Costing model can be adapted to fit another department. The specific resources, activities, and outputs must be identified and properly defined for another department. The analysis presented in this thesis is germane to research on cost models in another academic department. The basic structure of the current model

should be applicable. Development and implementation of an Activity Based Costing model for each academic and administrative department at the Naval Postgraduate School should be considered if the benefits from the models in the previous departments prove to outweigh the costs of development and implementation.

Lastly, research should be conducted to determine the applicability of Activity Based Costing at other Department of the Navy academic institutions. Activity Based Costing models similar to the one developed in this thesis could be adapted for use at schools such as the Marine Corps University or the Naval War College. The starting point for development and implementation of a model could be the analysis discussed in chapter IV of this thesis. Potential benefits include a justification for resource use and a budgeting tool that models organizational processes.

## LIST OF REFERENCES

Barron, Joseph, Director of Academic Planning at the Naval Postgraduate School; Interview with the author on November 16, 1994.

Bartolini, Evelyn M., Travel technician in the Mechanical Engineering department; Interview with the author on November 14, 1994.

Buckley, John W. and Marlene H.; Chiang, Hung-Fu; *Research Methodology and Business Decisions*, 1976, National Association of Accountants.

Collins, Frank, editor; *Implementing Activity-Based Costing*, 1991.

Congressional Budget Office, U. S. Congress; *The Economic and Budget Outlook: Fiscal Years 1994 - 1998*, January, 1993.

Cooper, Robin; *Cost Classification in Unit-Based and Activity-Based Manufacturing Systems*, Journal of Cost Management, Fall, 1990, pages 4-14.

Cooper, Robin; Presentations from six monographs based on the field study of twenty Japanese manufacturers, American Accounting Association, Management Accounting Research Conference, April 8-9, 1994.

Cooper, Robin; Kaplan, Robert S.; *How Cost Accounting Distorts Product Costs*, Management Accounting, April 1988, pages 20-27.

Cooper, Robin; Kaplan, Robert S.; Maisal, Lawrence S.; Morrissey, Eileen; Oehm, Ronald M.; *Implementing Activity-Based Cost Management: Moving from Analysis to Action*, 1992, Institute of Management Accountants.

Davis, Pam, Naval Engineering education technician; Interview with the author on October 13, 1994.

Deakin, Edward B.; Maher, Michael W.; *Cost Accounting, Third Edition*, 1991, Irwin, Homewood, IL, pages 41-45.

Defense Business Operations Fund Improvement Plan, September 24, 1993.

Ferrara, William L. and Hayya, Jack C.; *Toward Probabilistic Profit Budgets*, Management Accounting, October, 1970.

Goldich, Robert L., and Daggett, Stephen, Foreign Affairs and National Defense Division of the Congressional Research Service, *Defense Goals in the 1990's*, updated February 20, 1990.

Hutchins, Michelle F., Clerk typist and travel technician in the Mechanical Engineering department; Interview with the author on November 8, 1994.

Jay, Robert, Comptroller of the Naval Postgraduate School; Interview with the author on July 16, 1994.

Johnson, H. Thomas, *Relevance Regained: From Top-Down Control to Bottom-Up Empowerment*, 1992, The Free Press, NY, pages 133-139.

Johnson, H. Thomas, and Kaplan, Robert S., *Relevance Lost: The Rise and Fall of Management Accounting*, 1987, Harvard Business School Press, Boston, MA.

Joyce, Judy, Staff assistant in the Office of Academic Planning at the Naval Postgraduate School; Interviews with the author on September 2, September 6, and October 24, 1994.

Kalmar, Louis G. CDR, USN, Military Instructor at the Naval Postgraduate School, *Practical Comptrollership*, revised March, 1994.

Keith, Robert, Congressional Research Service; *Budget Enforcement in 1992*, May 27, 1992.

Kelleher, Matthew D., Professor and Chairman of the Mechanical Engineering department; Interviews with the author on June 28, September 22, November 2, and November 14, 1994.

Kerol, Glendo L., Supply Technician in the Mechanical Engineering department; Interviews with the author on August 31, October 13, November 1, and November 14, 1994.

Kuska, Danielle, Research Programs Supervisor in the office of the Dean of Research; Interviews with the author on August 31 and October 6, 1994.

Management Accounting, June 1994, pages 15, 19, 36-37.

McCord, Thomas H., Professional Engineer and Laboratory Manager in the Mechanical Engineering department; Interviews with the author on July 8, and November 1, 1994.

McGuire, Alan G., Engineer in the Public Works department at the Naval Postgraduate School, participated in engineering study of utilities usage and cost estimation, 28 February, 1991.

McNelley, Terry R., Professor of Mechanical Engineering and Associate Chairman for Operations in the Mechanical Engineering department; Interviews with the author on July 11, and November 17, 1994.

Murdick, Robert F., *Business Research: Concept and Practice*, 1969, International Textbook Company, page 8.

Murdter, Michael, LCDR, USN, Public Works Officer at the Naval Postgraduate School; Interviews with the author on August 24 and September 21, 1994.

Murdter, Michael, LCDR, USN, Public Works Officer at the Naval Postgraduate School; Master's Thesis, *Utility Cost Accounting and Market Pricing of Electricity at the Naval Postgraduate School*, 1994.

Naval Postgraduate School 1994 Catalog.

NAVCOMPT Notice 7041, Office of the Comptroller of the Navy, 8 December 1992.

NetProphet II User Guide, 1994, pages 5-1 to 5-9.

Office of Technology Assessment, Congress of the United States, *After the Cold War: Living with Lower Defense Spending*, 1992.

O'Guin, Michael, *Focus the Factory with Activity-Based Costing*, Management Accounting, February 1990, pages 36-41.

Raffish, Norm, *How Much Does That Product Really Cost?*, Management Accounting, March 1991, pages 36-39.

Romano, Patrick L., *Where Is Cost Management Going? (Part Two)*, Management Accounting, September 1990, pages 61-62.

Rotch, William, *Implementing Activity-Based Costing*, 1991, Frank Collins, editor, Executive Enterprises Publications Co., Inc, New York, New York, pages 71-76.

Rotch, William, *Activity-Based Costing in Service Industries*, Journal of Cost Management for the Manufacturing Industry, Summer 1990, pages 4-14.

SECNAVINST 1524.2A, dated 27 March 1989. *Policies concerning the Naval Postgraduate School.*

Shank, John K., and Govindarajan, Vijay, *Strategic Cost Analysis: The Evolution from Managerial to Strategic Accounting*, 1989, Irwin, Boston, MA.

Turney, Peter B. B., *Common Cents: The ABC Performance Breakthrough*, 1991, Cost Technology, Hillsboro, OR.

**APPENDIX A. GRAPHICAL DEPICTION OF EACH BOX**

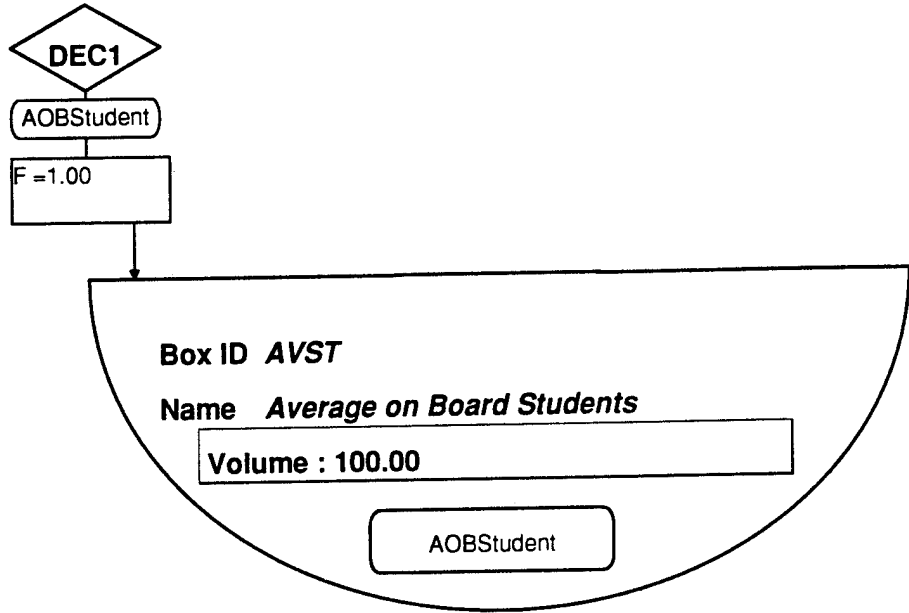

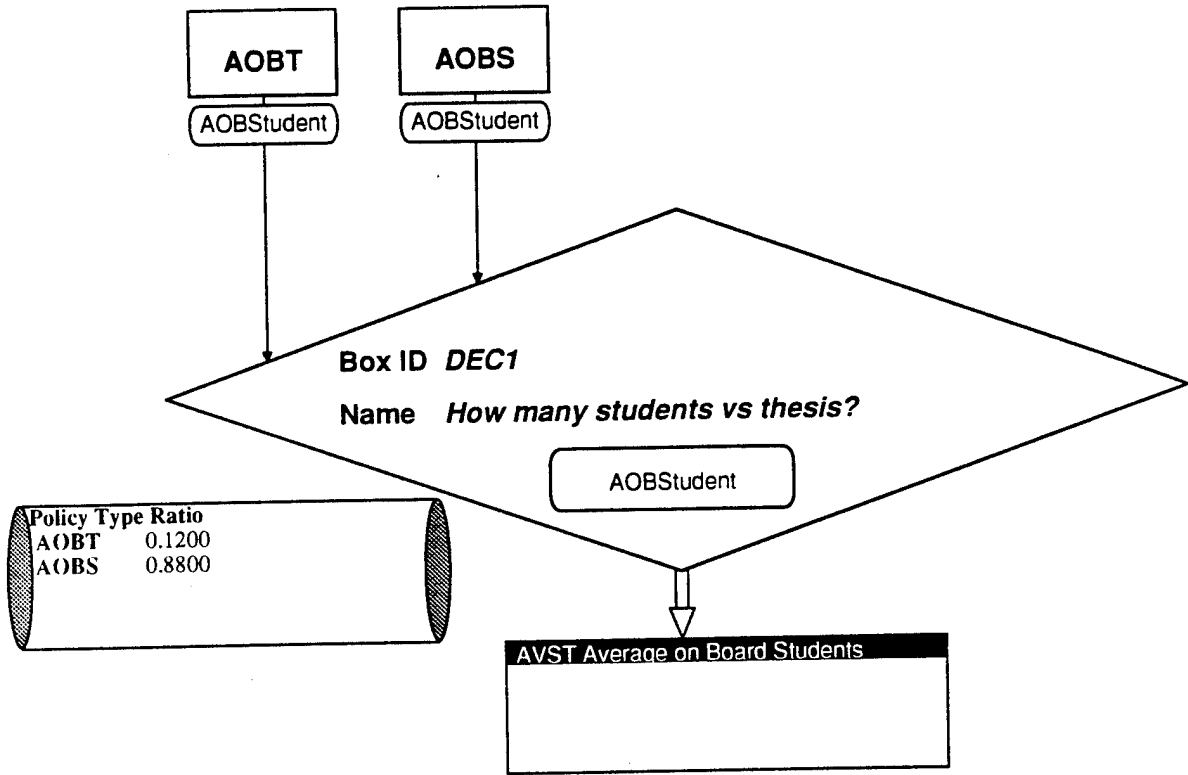

SUMR

Rsrch Prod

F = 1.00

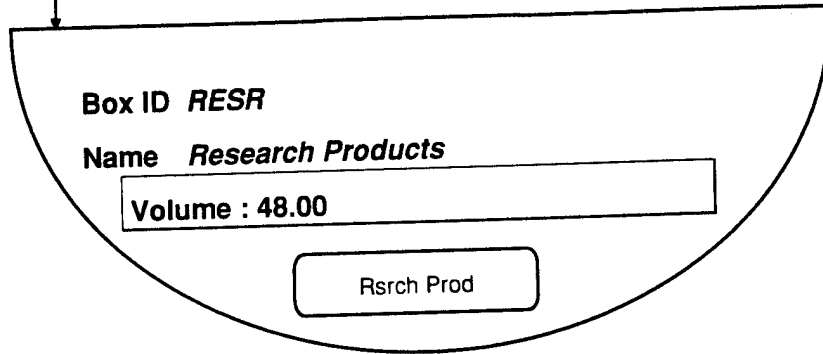

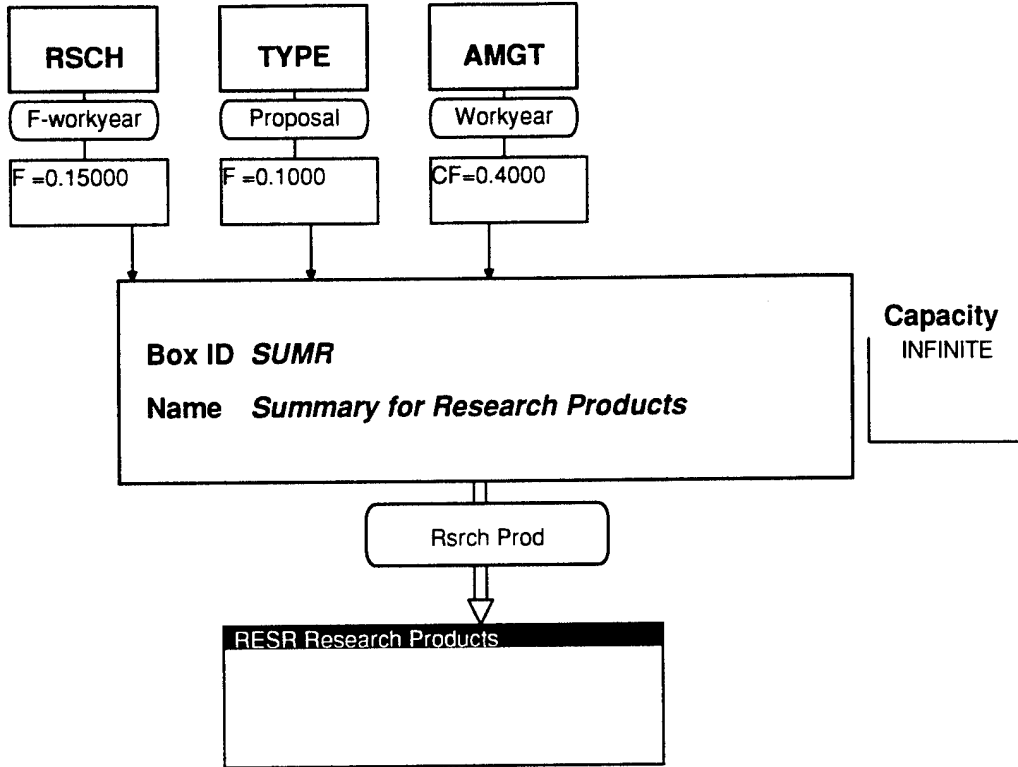

**SUMS**

Workyear

F = 1.00

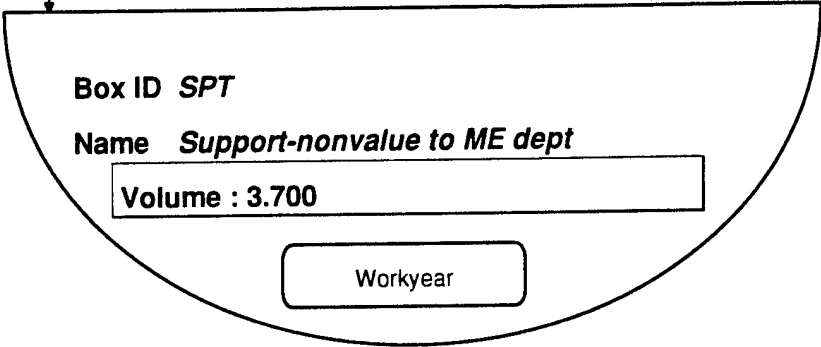

**OTH2**

Workyear

F = 1.00

**Box ID** *SUMS*  
**Name** *Summary for Support/nonvalue*

**Capacity**  
INFINITE

Workyear

SPT Support-nonvalue to ME dept

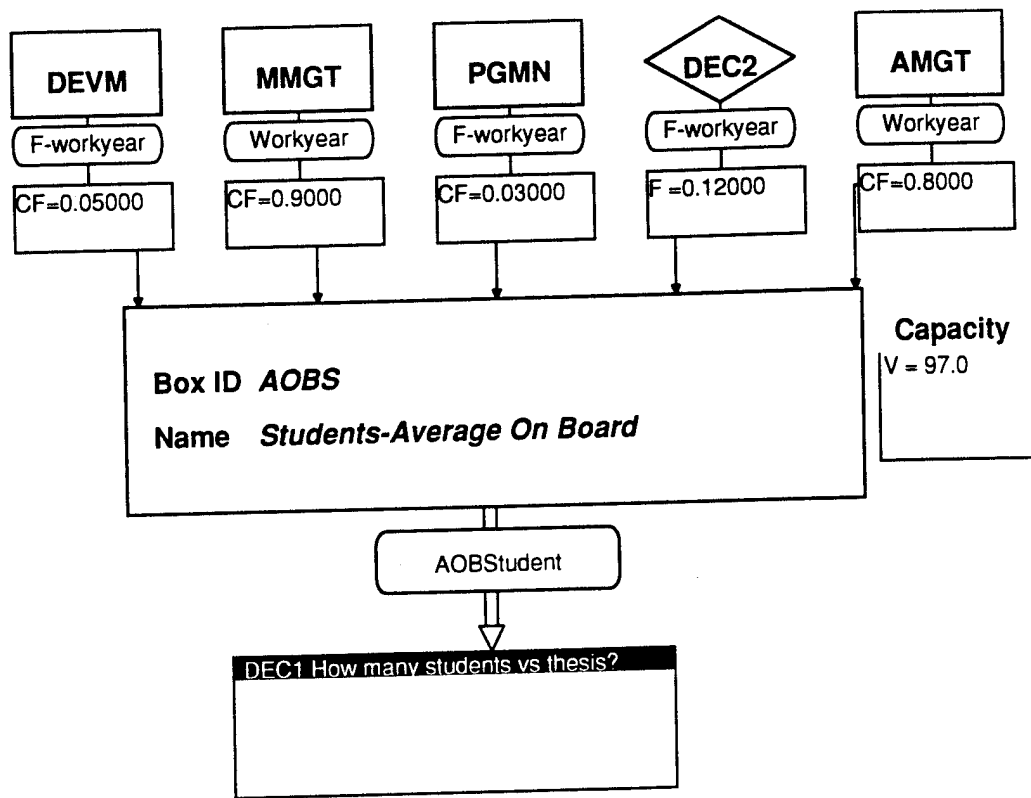

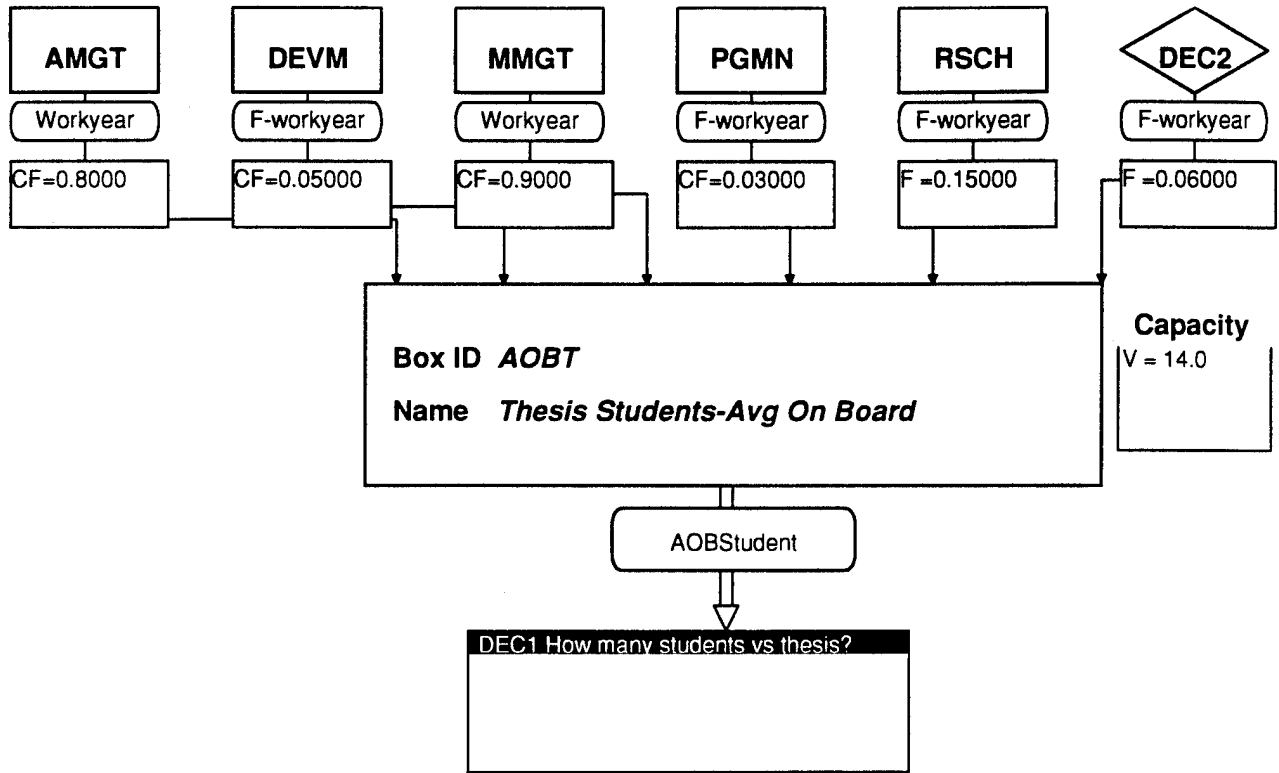

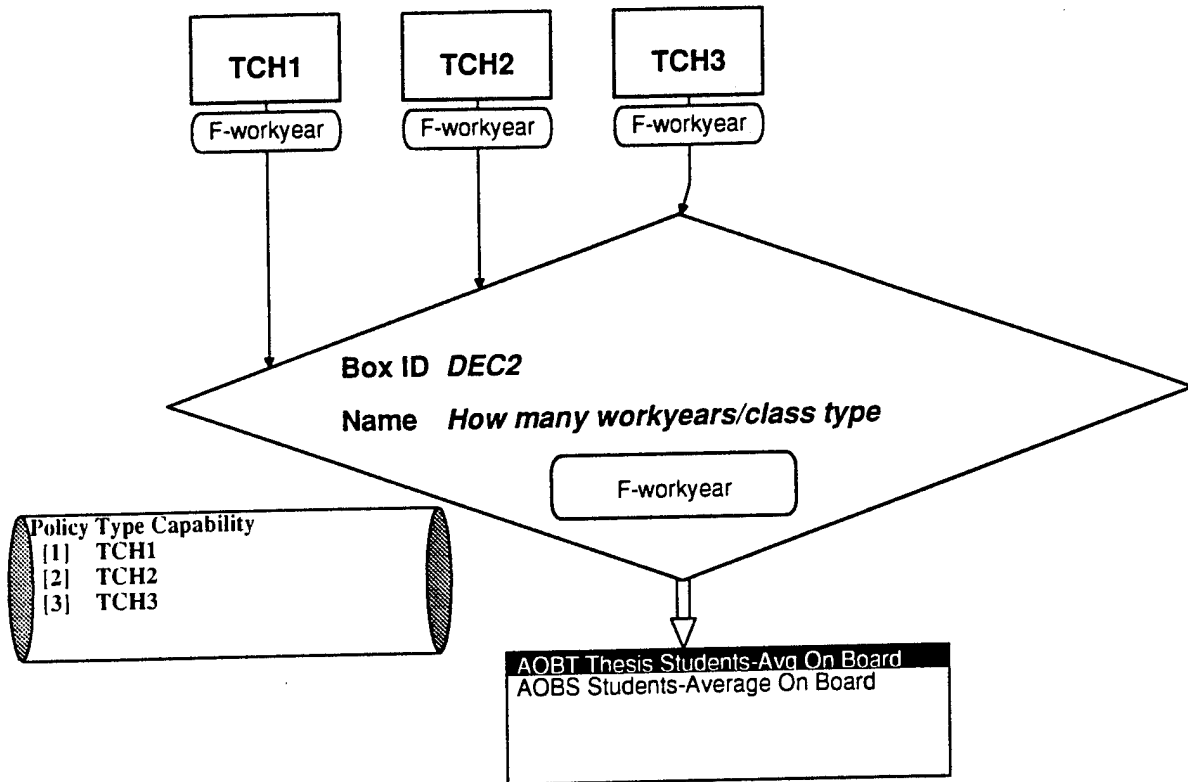

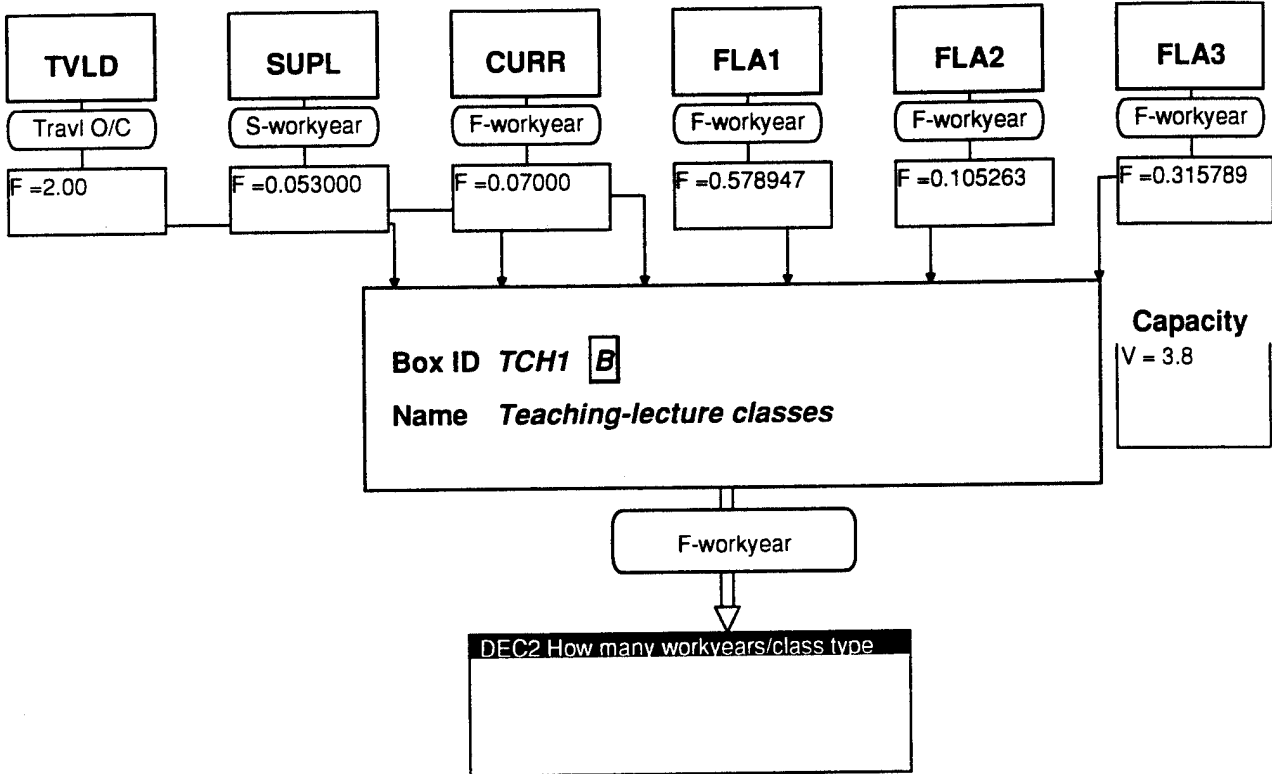

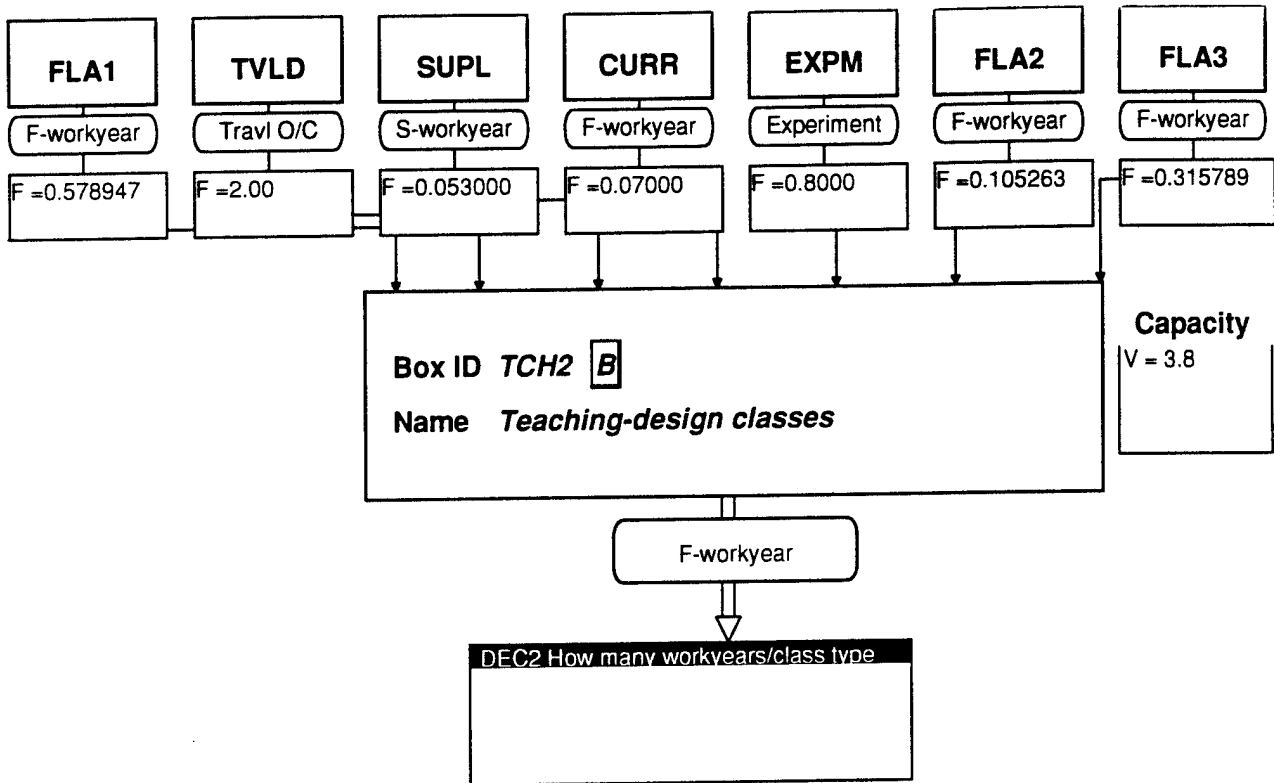

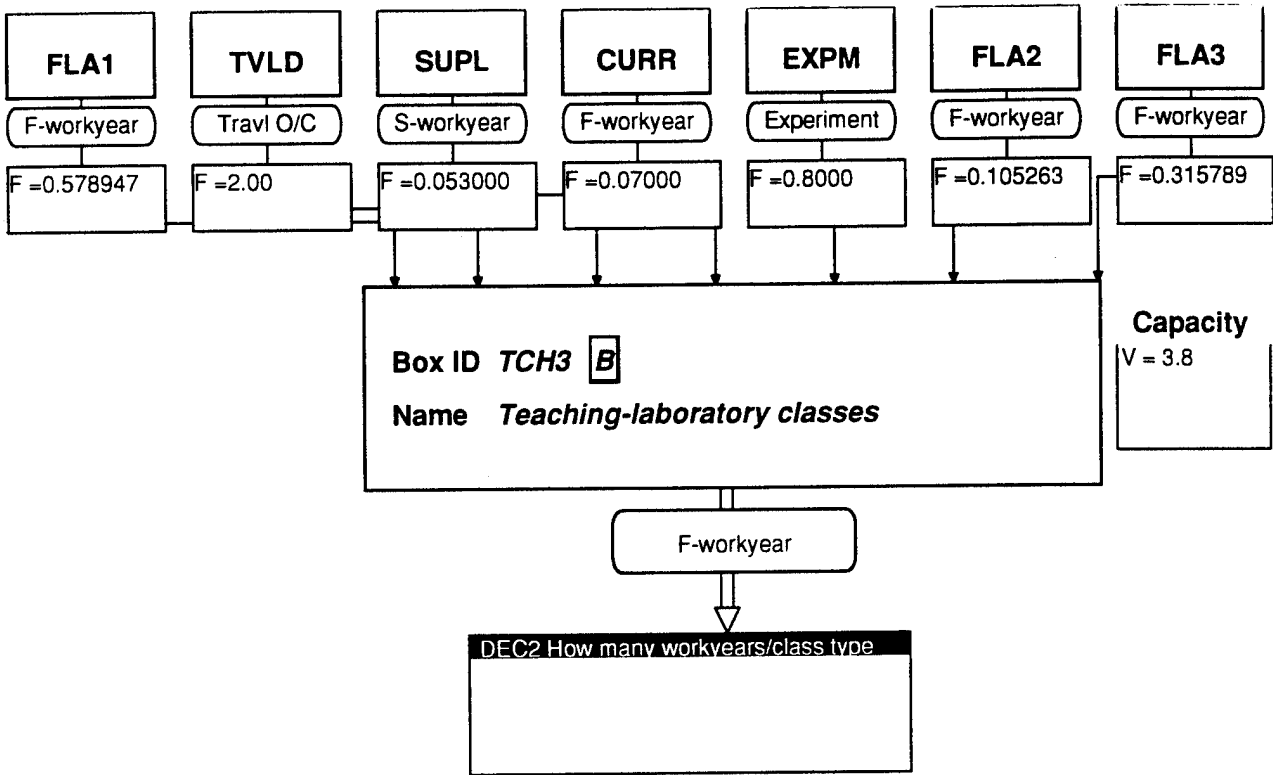

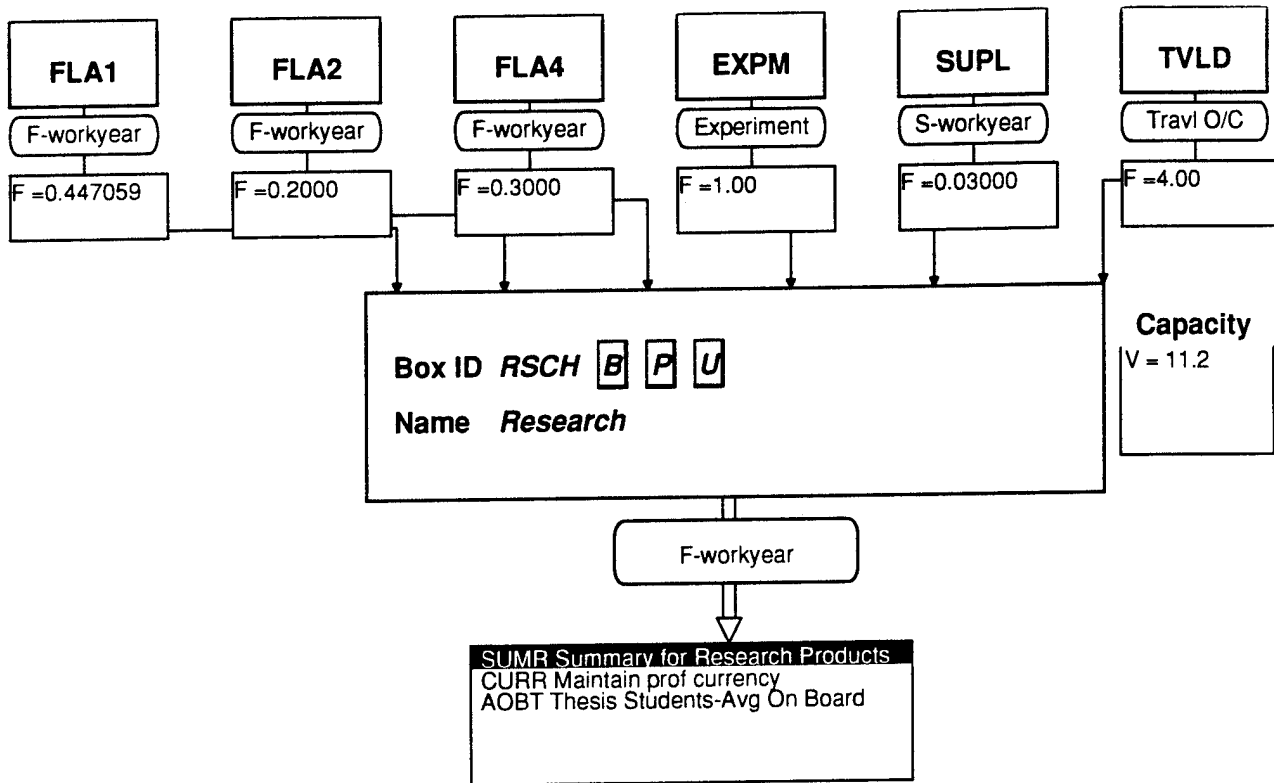

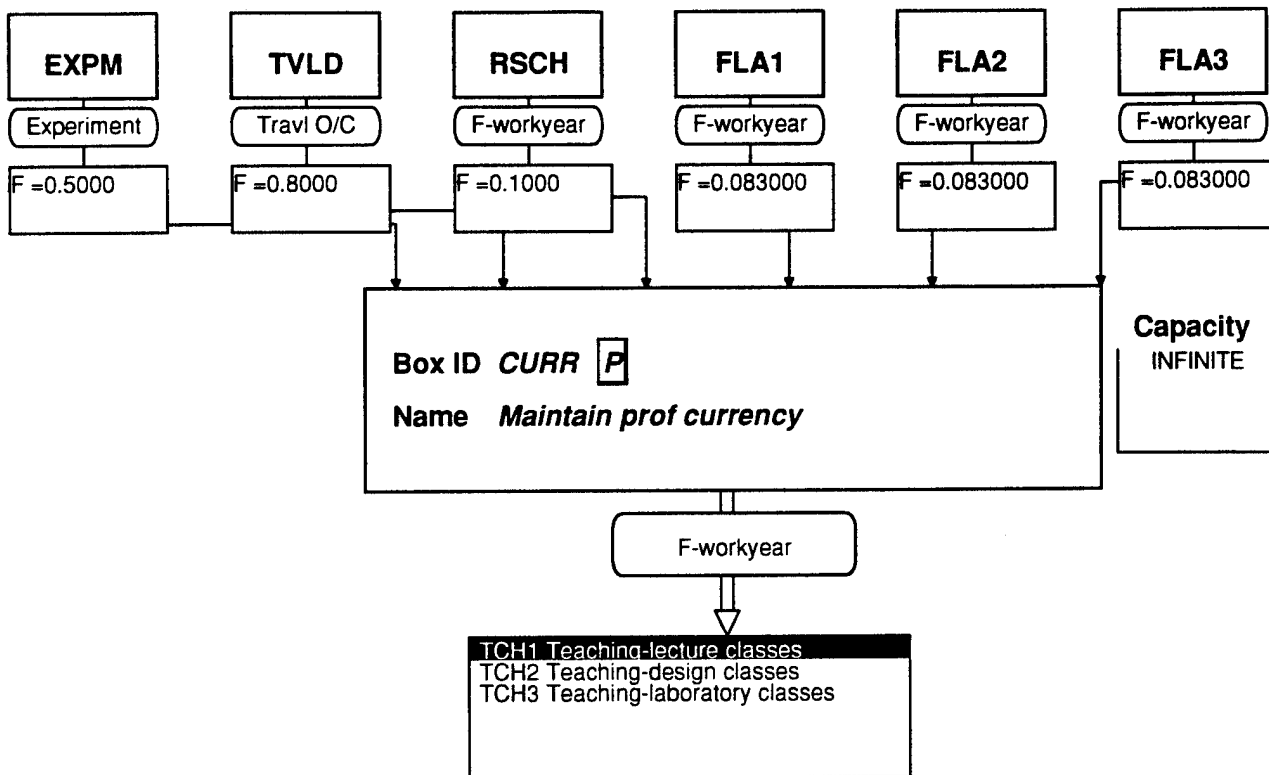

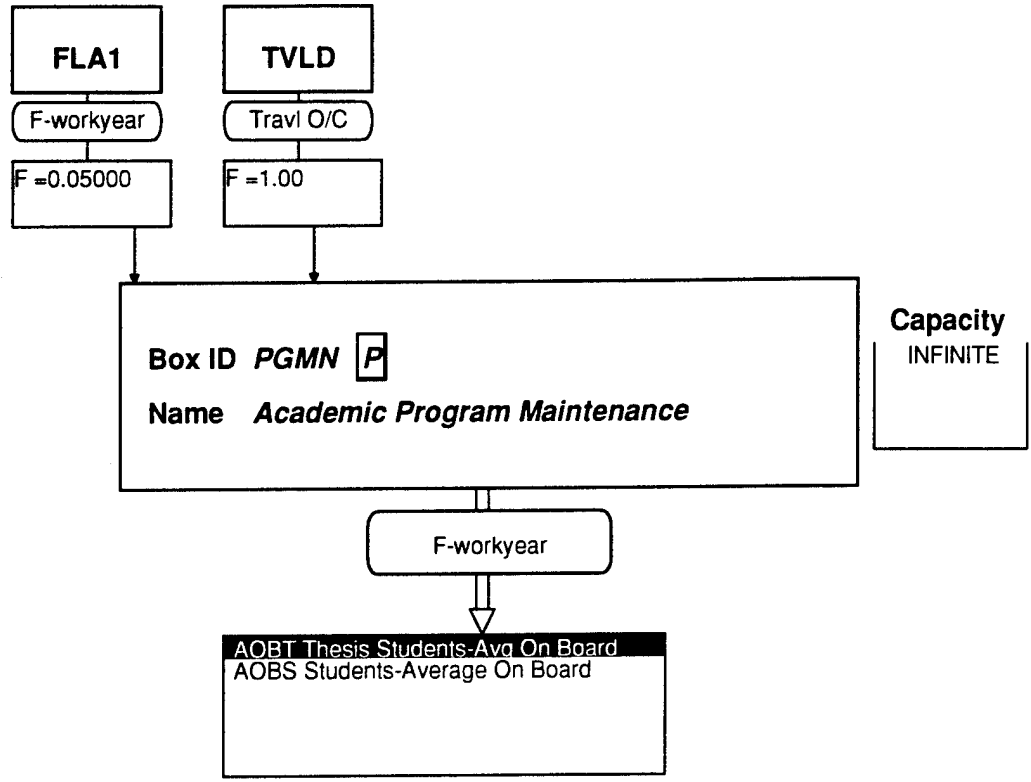

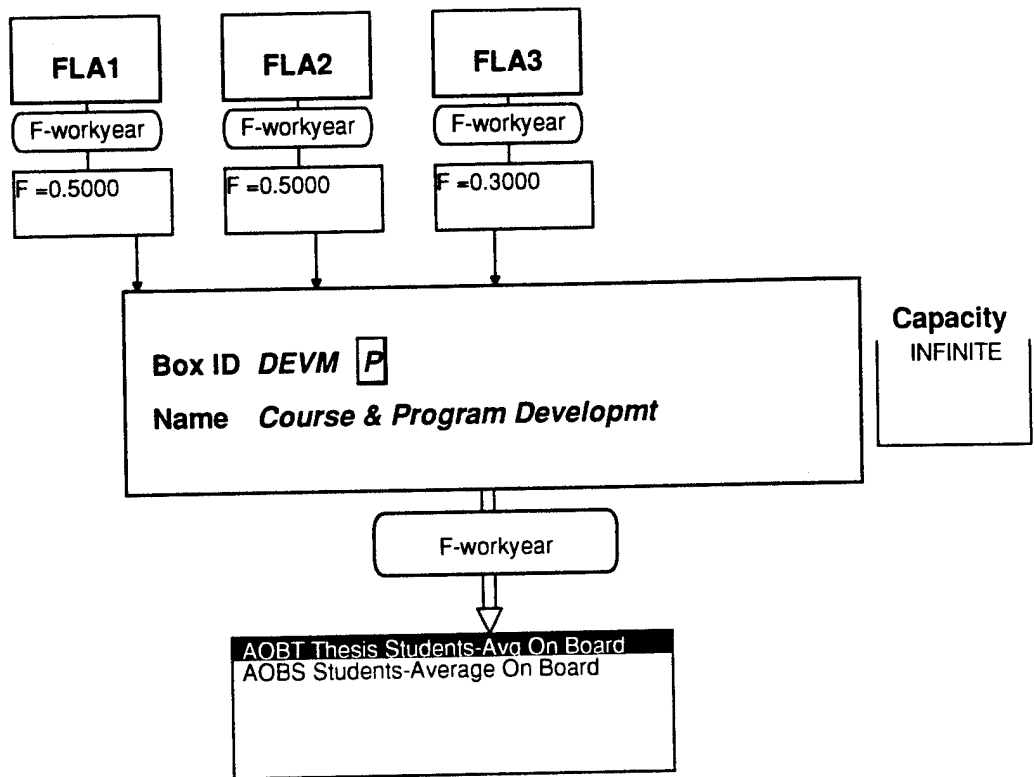

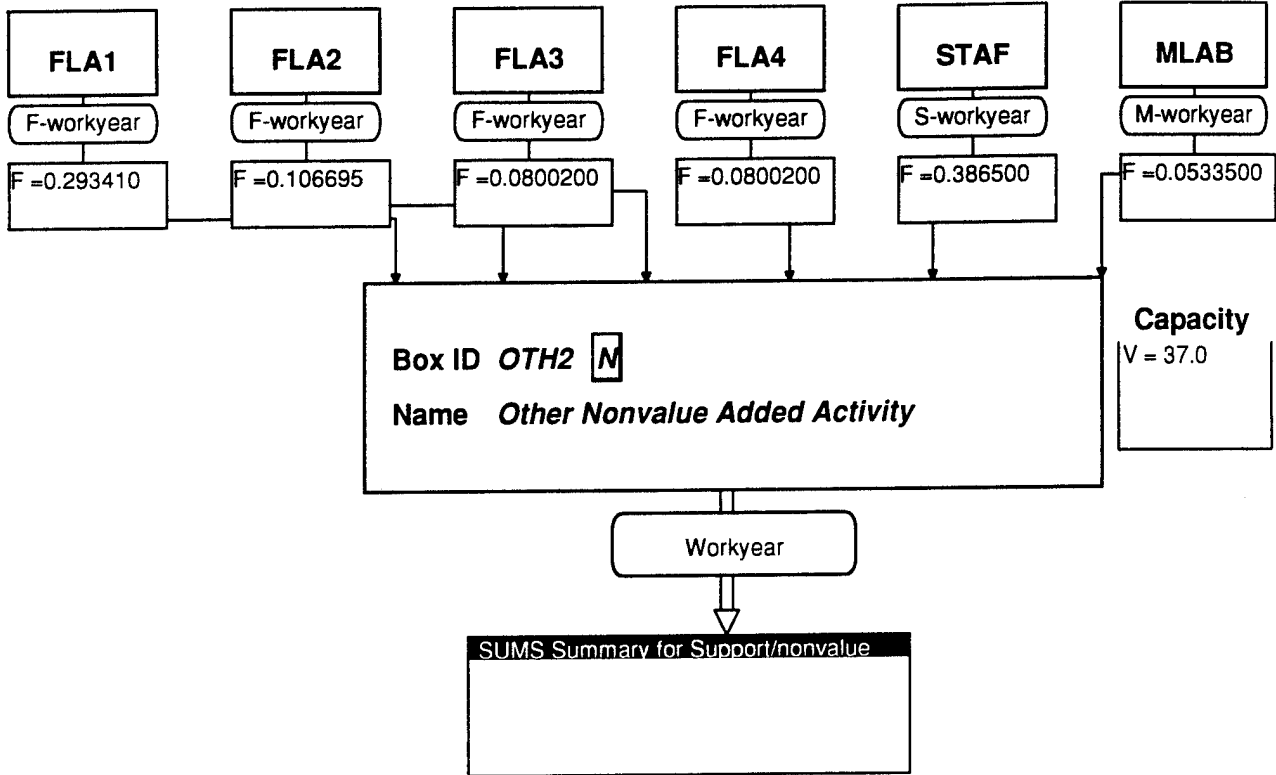

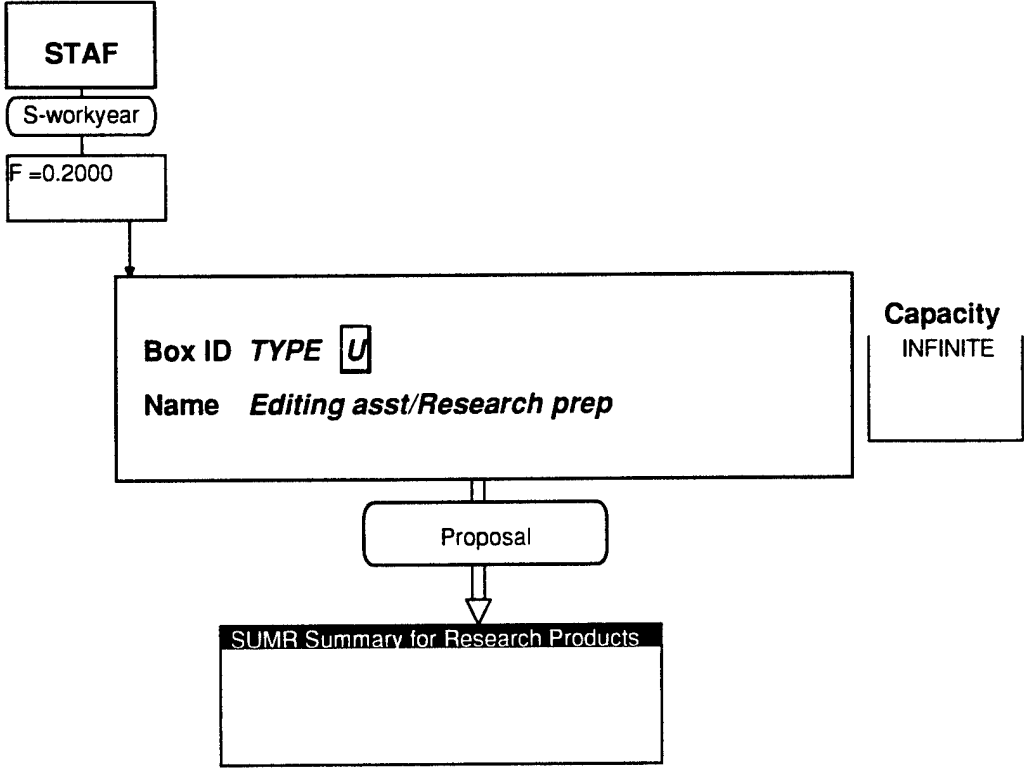

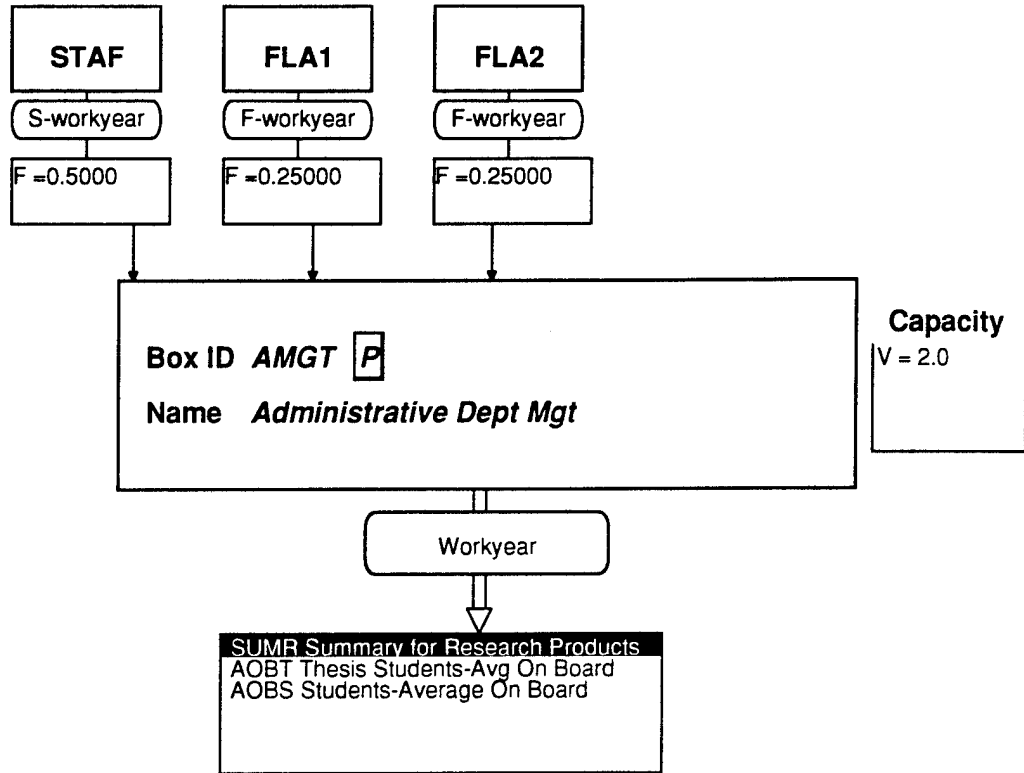

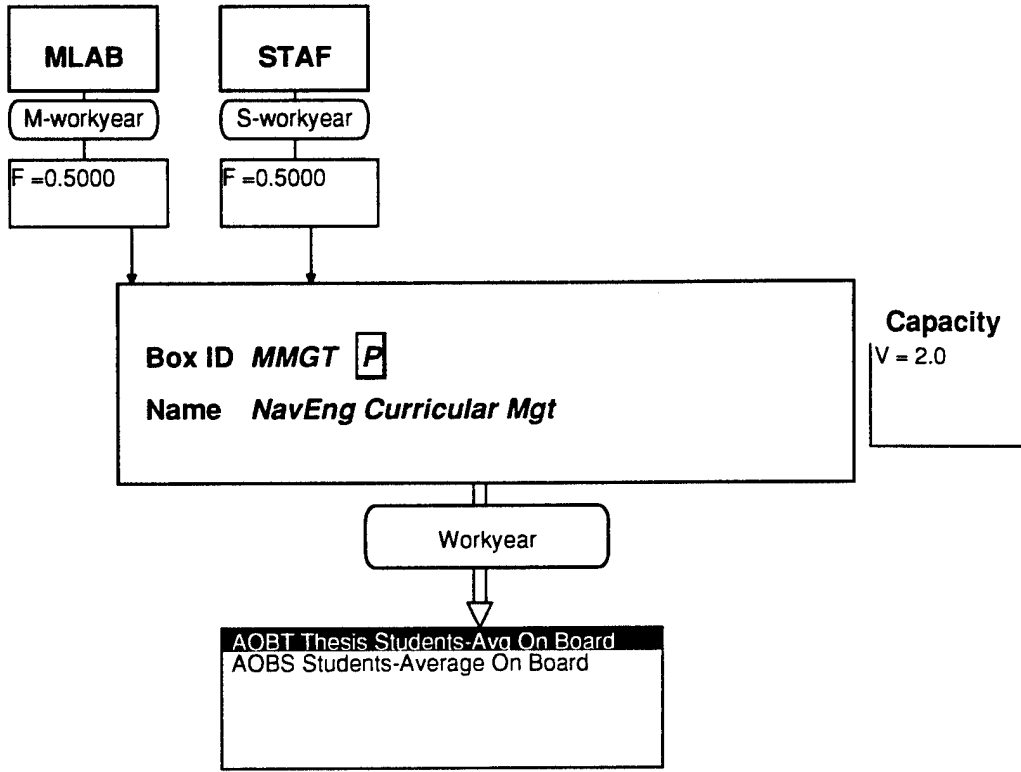

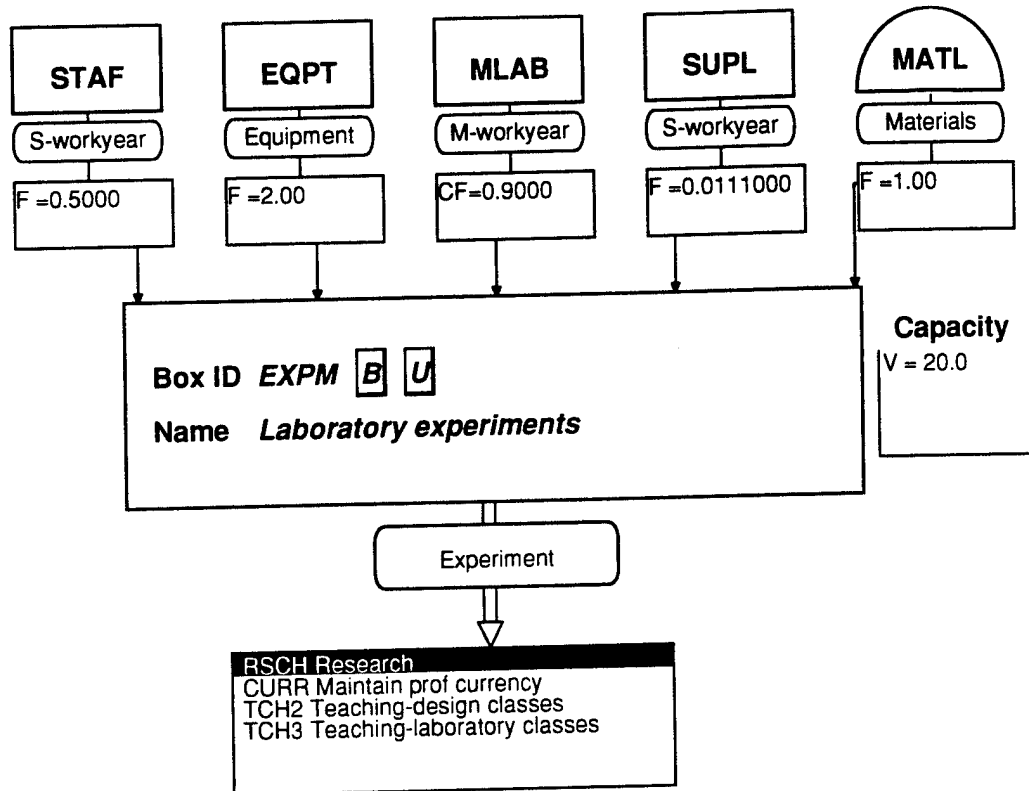

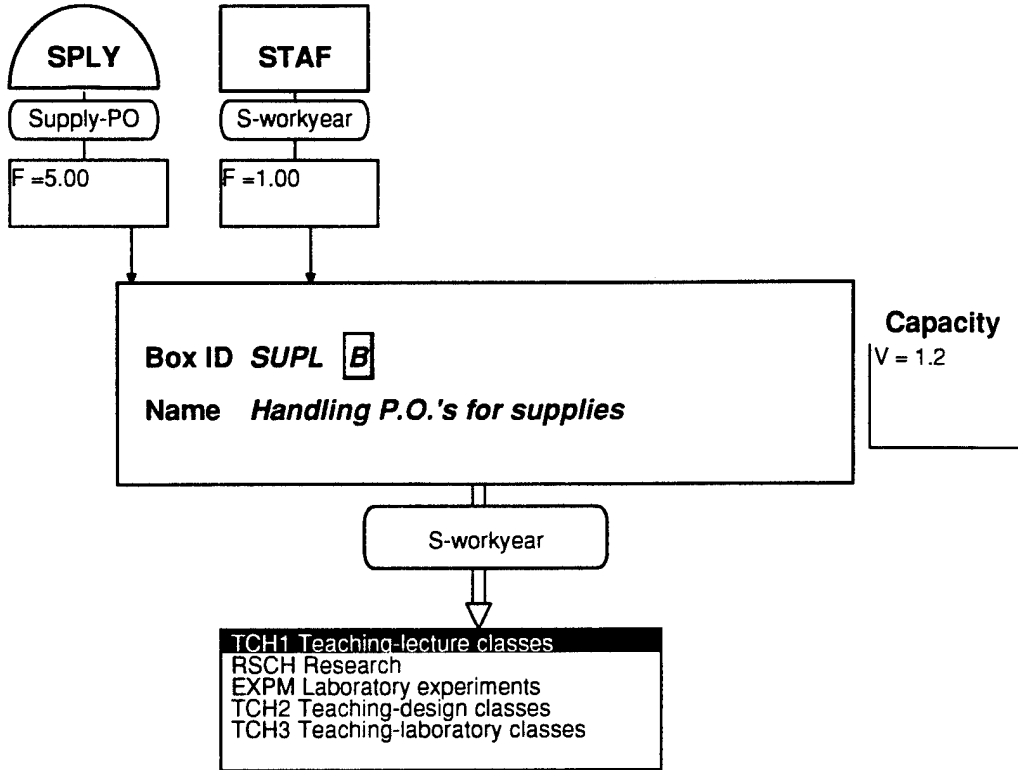

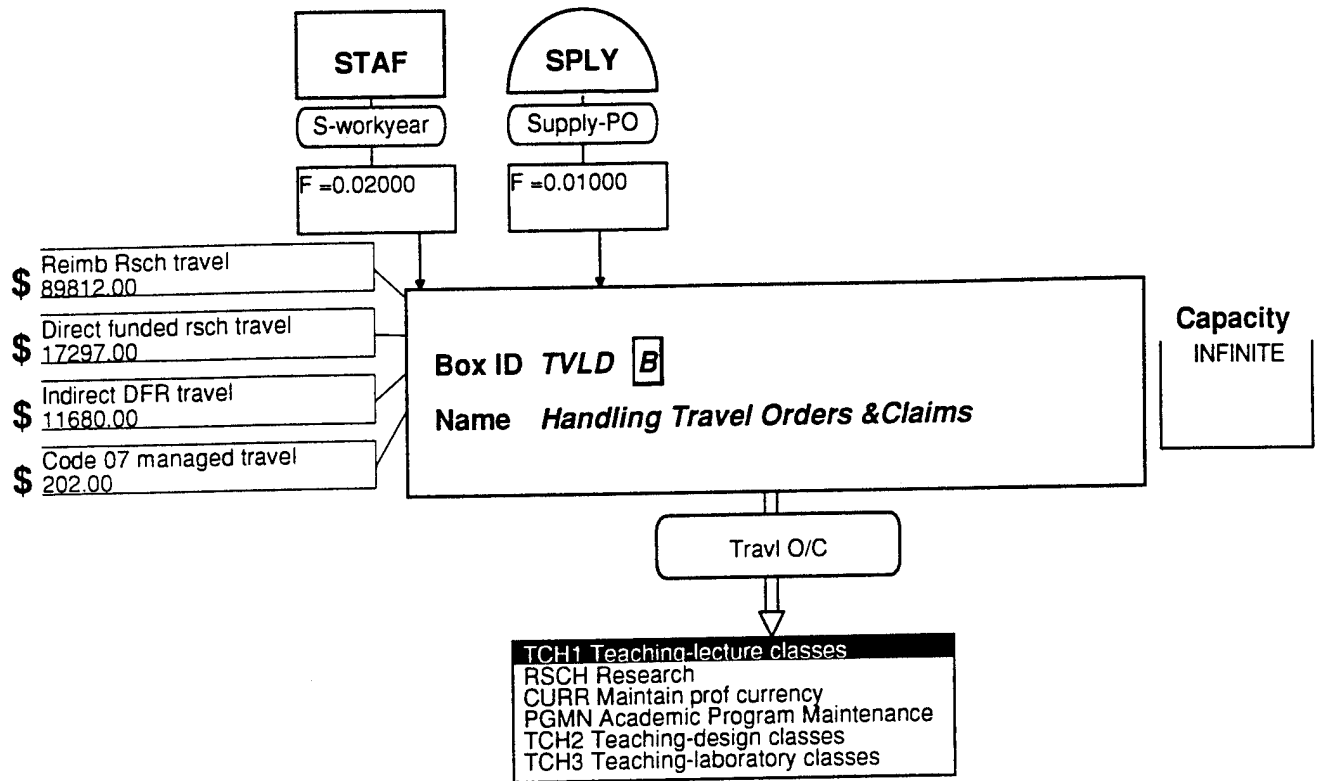

**FACL**

Usage

F = 1.00

\$ Staff O&MN labor: ME & Code 3  
45099.24 Civ#

\$ Staff RR labor: ME & Code 34  
1616.560 Civ#

**Box ID STAF**  
**Name Staff labor: ME dept & Code 34**

**Capacity**  
V = 14.5

S-workyear

TYPE Editing asst/Research prep  
EXPM Laboratory experiments  
OTH2 Other Nonvalue Added Activity  
SUPL Handling P.O.'s for supplies  
TVLD Handling Travel Orders & Claims  
AMGT Administrative Dept Mgt

**FACL**

Usage

F = 1.00

\$ Faculty O&M,N labor costs  
70628.49 #1

\$ Faculty RR labor costs  
37882.56 #1

**Box ID FLA1**  
**Name Fac labor: Tch 2/Rsch 2 qtrs**

**Capacity**  
V = 12.5

F-workyear

TCH1 Teaching-lecture classes  
RSCH Research  
OTH2 Other Nonvalue Added Activity  
DEVM Course & Program Developmt  
CURR Maintain prof currency  
PGMN Academic Program Maintenance

**FACL**

Usage

F = 1.00

\$ Faculty O&M,N labor costs  
70628.00 #2

\$ Faculty RR labor costs  
37883.00 #2

**Box ID FLA2**  
**Name Fac labor: Tch 1/Rsch 3 qtrs**

**Capacity**  
V = 4.3

F-workyear

**TCH1 Teaching-lecture classes**  
RSCH Research  
OTH2 Other Nonvalue Added Activity  
DEVM Course & Program Developmt  
CURR Maintain prof currency  
AMGT Administrative Dept Mgt

FACL

Usage

F = 1.00

\$ Faculty O&M,N labor costs  
70628.00 #3

\$ Faculty RR labor costs  
37883.00 #3

Box ID *FLA3*  
Name *Fac labor: Adj Teach 4 qtrs*

Capacity  
V = 4.0

F-workyear

- TCH1 Teaching-lecture classes
- OTH2 Other Nonvalue Added Activity
- DEVM Course & Program Developmt
- CURR Maintain prof currency
- TCH2 Teaching-design classes
- TCH3 Teaching-laboratory classes

**FACL**

Usage

F = 1.00

\$ Faculty O&M,N labor costs  
70628.00 #3

\$ Faculty RR labor costs  
37883.00 #3

**Box ID FLA4**  
**Name Fac labor: Adj Rsch 4 qtrs**

**Capacity**  
V = 3.3

F-workyear

**RSCH Research**  
OTH2 Other Nonvalue Added Activity

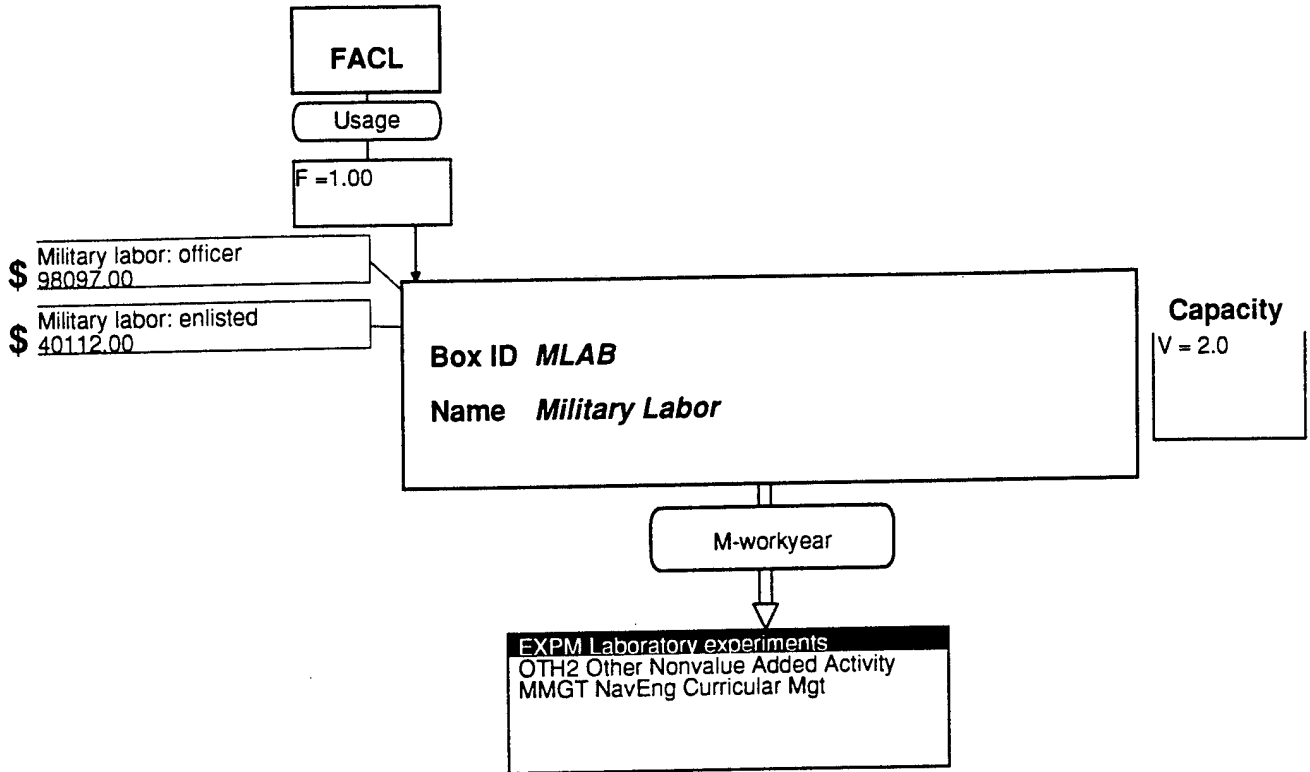



Contract

F = 1.00

\$ New equipment costs (O&M,N)  
18005.00

\$ New equipment costs (OP,N)  
39888.00

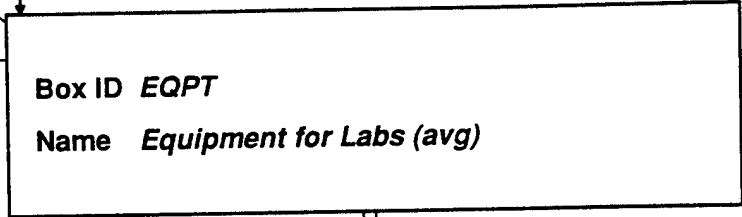

Capacity  
INFINITE

Equipment

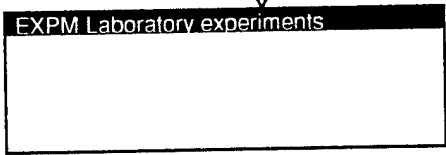

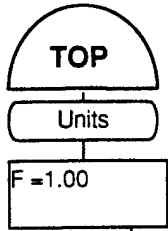

\$ Long Distance charges  
3000.00

\$ Utilities charges allocated  
193186.00

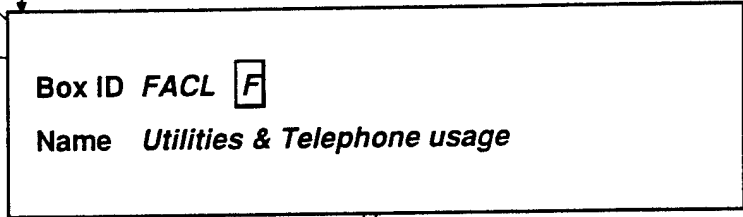

**Capacity**  
INFINITE

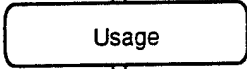

FLA1 Fac labor: Tch 2/Rsch 2 qtrs  
STAF Staff labor: ME dept & Code 34  
MLAB Military Labor  
FLA2 Fac labor: Tch 1/Rsch 3 qtrs  
FLA3 Fac labor: Adj Teach 4 qtrs  
FLA4 Fac labor: Adj Rsch 4 qtrs

\$ Equipment maintenance  
2000.00  
\$ Computer maintenance  
1000.00

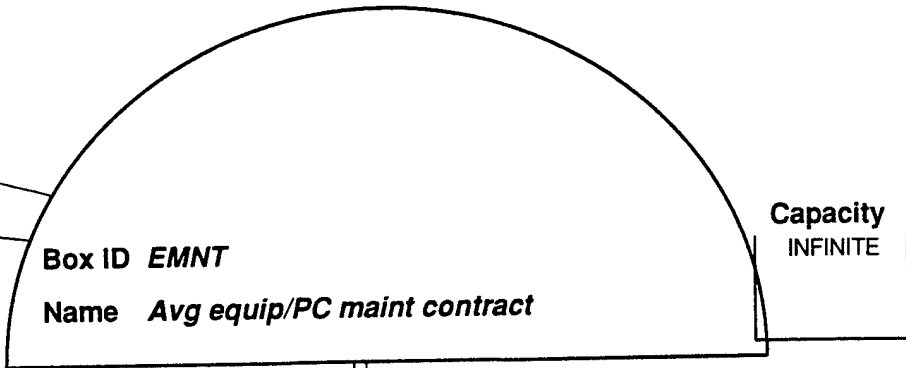

Contract

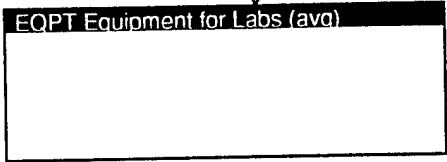

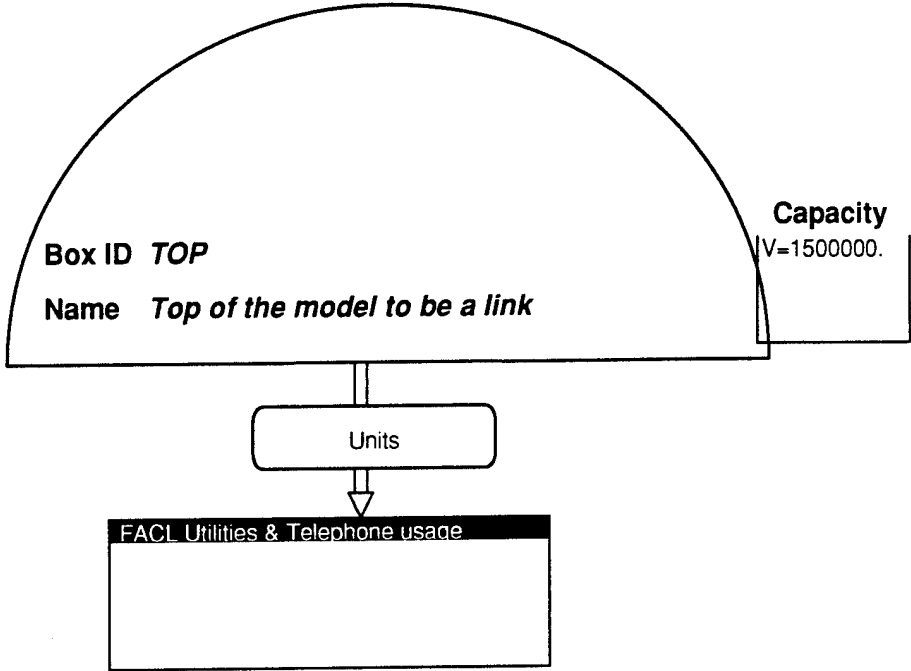

\$ Materials for experiments  
1800.00

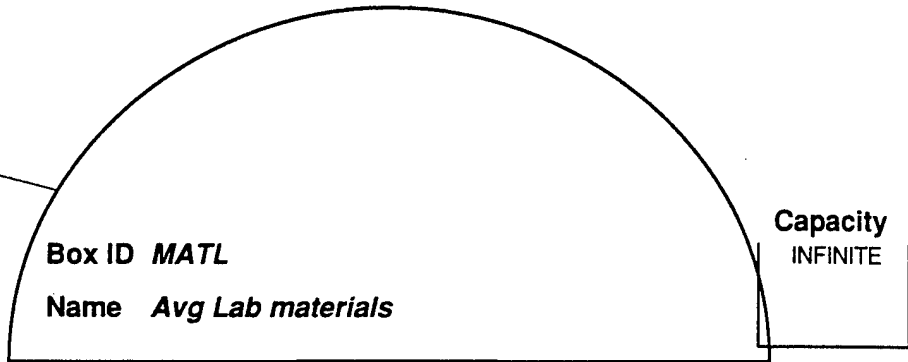

Materials

EXPM Laboratory experiments

\$ Supplies for ME dept  
2500.00

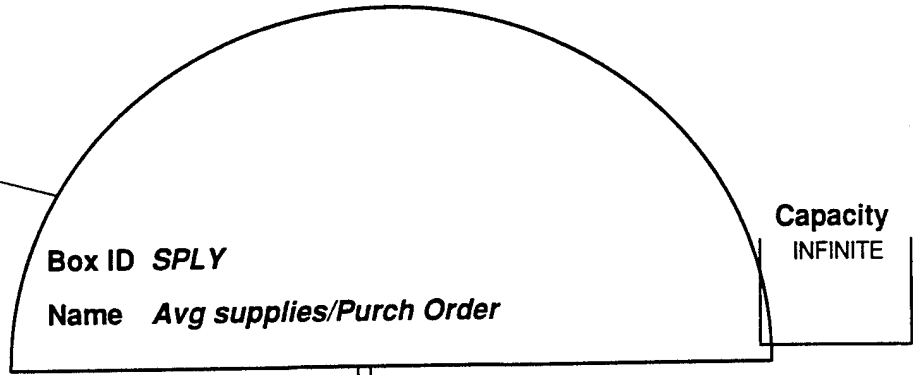

Supply-PO

SUPL Handling P.O.'s for supplies  
TVLD Handling Travel Orders & Claims

## APPENDIX B. MODEL INFORMATION

MODEL TITLE : NPS Mechanical Engineering Department Revision Three

=====

MODEL PERIODS :

PERIOD #	LABEL
1	Year 1
2	Year 2
3	5 months
4	Cumulative

MODEL UNITS :

Rsrch Prod  
PurchOrder  
Travl O/C  
Experiment  
Contract  
Units  
Proposal  
Workyear  
AOBStudent  
Materials  
F-workyear  
S-workyear  
Supply-PO  
Usage  
M-workyear  
Equipment

MODEL REVENUE/COST CATEGORIES :

CATEGORY #	NAME
100	Total labor costs
101	Faculty O&M,N labor costs
102	Faculty RR labor costs
103	Military labor: officer
104	Military labor: enlisted
110	Staff O&MN labor: ME & Code 34
111	Staff RR labor: ME & Code 34
200	Total travel costs
201	Reimb Rsch travel
202	Direct funded rsch travel
203	Indirect DFR travel
205	Code 07 managed travel
300	Total Equipment costs
301	New equipment costs (O&M,N)
302	Equipment maintenance
305	Computer maintenance
307	New equipment costs (OP,N)
400	Total Supplies
401	Supplies for ME dept
402	Materials for experiments
500	Total Telephone charges
501	Long Distance charges
600	Total Utilities charges
601	Utilities charges allocated

MODEL TITLE : NPS Mechanical Engineering Department Revision Three

=====

MODEL REVENUE/COST CATEGORIES : (Cont.)

CATEGORY #      NAME

MODEL MULTIPLIERS :

MULTIPLIER	PERIODS			
IDs	Year 1	Year 2	5 months	Cumulative
Civ#	14.49	14.49	14.49	14.49
#1	11.00	11.00	11.00	11.00
#2	4.00	4.00	4.00	4.00
#3	3.00	3.00	3.00	3.00

MODEL TAGS :

TAG ID	NAME
N	Nonvalue added
U	Unit level activity
B	Batch level activity
P	Product level activity
F	Facility level activity



## APPENDIX C. MODEL NETWORK REPORT

MODEL TITLE : NPS Mechanical Engineering Department Revision Three

	Box Type	Units	Tags
Box AVST Average on Board Students	Demand	AOBStudent	
Entry Links :			
DECL How many students vs thesis?	Route	AOBStudent	
Box RESR Research Products	Demand	Rsrch Prod	
Entry Links :			
SUMR Summary for Research Products	Process	Rsrch Prod	
Box SPT Support-nonvalue to ME dept	Demand	Workyear	
Entry Links :			
SUMS Summary for Support/nonvalue	Process	Workyear	

MODEL TITLE : NPS Mechanical Engineering Department Revision Three

	Box Type	Units	Tags
Box DEC1 How many students vs thesis?	Route	AOBStudent	
Entry Links :			
AOBT Thesis Students-Avg On Board	Process	AOBStudent	
AOBS Students-Average On Board	Process	AOBStudent	
Box DEC2 How many workyears/class type	Route	F-workyear	
Entry Links :			
TCH1 Teaching-lecture classes	Process	F-workyear	B
TCH2 Teaching-design classes	Process	F-workyear	B
TCH3 Teaching-laboratory classes	Process	F-workyear	B

MODEL TITLE : NPS Mechanical Engineering Department Revision Three

	Box Type	Units	Tags
Box AMGT Administrative Dept Mgt	Process	Workyear	P
Entry Links :			
STAF Staff labor: ME dept & Code 34	Process	S-workyear	
FLA1 Fac labor: Tch 2/Rsch 2 qtrs	Process	F-workyear	
FLA2 Fac labor: Tch 1/Rsch 3 qtrs	Process	F-workyear	
Box AOBST Students-Average On Board	Process	AOBStudent	
Entry Links :			
DEVM Course & Program Developmt	Process	F-workyear	P
MMGT NavEng Curricular Mgt	Process	Workyear	P
PGMN Academic Program Maintenance	Process	F-workyear	P
DEC2 How many workyears/class type	Route	F-workyear	
AMGT Administrative Dept Mgt	Process	Workyear	P
Box AOBT Thesis Students-Avg On Board	Process	AOBStudent	
Entry Links :			
AMGT Administrative Dept Mgt	Process	Workyear	P
DEVM Course & Program Developmt	Process	F-workyear	P
MMGT NavEng Curricular Mgt	Process	Workyear	P
PGMN Academic Program Maintenance	Process	F-workyear	P
RSCH Research	Process	F-workyear	BPU
DEC2 How many workyears/class type	Route	F-workyear	
Box CURR Maintain prof currency	Process	F-workyear	P
Entry Links :			
EXPM Laboratory experiments	Process	Experiment	BU
TVLD Handling Travel Orders &Claims	Process	Travl O/C	B
RSCH Research	Process	F-workyear	BPU
FLA1 Fac labor: Tch 2/Rsch 2 qtrs	Process	F-workyear	
FLA2 Fac labor: Tch 1/Rsch 3 qtrs	Process	F-workyear	
FLA3 Fac labor: Adj Teach 4 qtrs	Process	F-workyear	
Box DEVM Course & Program Developmt	Process	F-workyear	P
Entry Links :			
FLA1 Fac labor: Tch 2/Rsch 2 qtrs	Process	F-workyear	
FLA2 Fac labor: Tch 1/Rsch 3 qtrs	Process	F-workyear	
FLA3 Fac labor: Adj Teach 4 qtrs	Process	F-workyear	
Box EQPT Equipment for Labs (avg)	Process	Equipment	
Entry Links :			
EMNT Avg equip/PC maint contract	Supply	Contract	

MODEL NETWORK REPORT

MODEL TITLE : NPS Mechanical Engineering Department Revision Three

	Box Type	Units	Tags
Box EXPM Laboratory experiments	Process	Experiment	BU
Entry Links :			
STAF Staff labor: ME dept & Code 34	Process	S-workyear	
EQPT Equipment for Labs (avg)	Process	Equipment	
MLAB Military Labor	Process	M-workyear	
SUPL Handling P.O.'s for supplies	Process	S-workyear	B
MATL Avg Lab materials	Supply	Materials	
Box FACL Utilities & Telephone usage	Process	Usage	F
Entry Links :			
TOP Top of the model to be a link	Supply	Units	
Box FLA1 Fac labor: Tch 2/Rsch 2 qtrs	Process	F-workyear	
Entry Links :			
FACL Utilities & Telephone usage	Process	Usage	F
Box FLA2 Fac labor: Tch 1/Rsch 3 qtrs	Process	F-workyear	
Entry Links :			
FACL Utilities & Telephone usage	Process	Usage	F
Box FLA3 Fac labor: Adj Teach 4 qtrs	Process	F-workyear	
Entry Links :			
FACL Utilities & Telephone usage	Process	Usage	F
Box FLA4 Fac labor: Adj Rsch 4 qtrs	Process	F-workyear	
Entry Links :			
FACL Utilities & Telephone usage	Process	Usage	F
Box MLAB Military Labor	Process	M-workyear	
Entry Links :			
FACL Utilities & Telephone usage	Process	Usage	F
Box MMGT NavEng Curricular Mgt	Process	Workyear	P
Entry Links :			
MLAB Military Labor	Process	M-workyear	
STAF Staff labor: ME dept & Code 34	Process	S-workyear	

MODEL TITLE : NPS Mechanical Engineering Department Revision Three

	Box Type	Units	Tags
Box OTH2 Other Nonvalue Added Activity	Process	Workyear	N
Entry Links :			
FLA1 Fac labor: Tch 2/Rsch 2 qtrs	Process	F-workyear	
FLA2 Fac labor: Tch 1/Rsch 3 qtrs	Process	F-workyear	
FLA3 Fac labor: Adj Teach 4 qtrs	Process	F-workyear	
FLA4 Fac labor: Adj Rsch 4 qtrs	Process	F-workyear	
STAF Staff labor: ME dept & Code 34	Process	S-workyear	
MLAB Military Labor	Process	M-workyear	
Box PGMN Academic Program Maintenance	Process	F-workyear	P
Entry Links :			
FLA1 Fac labor: Tch 2/Rsch 2 qtrs	Process	F-workyear	
TVLD Handling Travel Orders &Claims	Process	Travl O/C	B
Box RSCH Research	Process	F-workyear	BPU
Entry Links :			
FLA1 Fac labor: Tch 2/Rsch 2 qtrs	Process	F-workyear	
FLA2 Fac labor: Tch 1/Rsch 3 qtrs	Process	F-workyear	
FLA4 Fac labor: Adj Rsch 4 qtrs	Process	F-workyear	
EXPM Laboratory experiments	Process	Experiment	BU
SUPL Handling P.O.'s for supplies	Process	S-workyear	B
TVLD Handling Travel Orders &Claims	Process	Travl O/C	B
Box STAF Staff labor: ME dept & Code 34	Process	S-workyear	
Entry Links :			
FACL Utilities & Telephone usage	Process	Usage	F
Box SUMR Summary for Research Products	Process	Rsrch Prod	
Entry Links :			
RSCH Research	Process	F-workyear	BPU
TYPE Editing asst/Research prep	Process	Proposal	U
AMGT Administrative Dept Mgt	Process	Workyear	P
Box SUMS Summary for Support/nonvalue	Process	Workyear	
Entry Links :			
OTH2 Other Nonvalue Added Activity	Process	Workyear	N
Box SUPL Handling P.O.'s for supplies	Process	S-workyear	B
Entry Links :			
SPLY Avg supplies/Purch Order	Supply	Supply-PO	
STAF Staff labor: ME dept & Code 34	Process	S-workyear	

MODEL NETWORK REPORT

MODEL TITLE : NPS Mechanical Engineering Department Revision Three

	Box Type	Units	Tags
Box TCH1 Teaching-lecture classes	Process	F-workyear	B
Entry Links :			
TVLD Handling Travel Orders &Claims	Process	Travl O/C	B
SUPL Handling P.O.'s for supplies	Process	S-workyear	B
CURR Maintain prof currency	Process	F-workyear	P
FLA1 Fac labor: Tch 2/Rsch 2 qtrs	Process	F-workyear	
FLA2 Fac labor: Tch 1/Rsch 3 qtrs	Process	F-workyear	
FLA3 Fac labor: Adj Teach 4 qtrs	Process	F-workyear	
Box TCH2 Teaching-design classes	Process	F-workyear	B
Entry Links :			
FLA1 Fac labor: Tch 2/Rsch 2 qtrs	Process	F-workyear	
TVLD Handling Travel Orders &Claims	Process	Travl O/C	B
SUPL Handling P.O.'s for supplies	Process	S-workyear	B
CURR Maintain prof currency	Process	F-workyear	P
EXPM Laboratory experiments	Process	Experiment	BU
FLA2 Fac labor: Tch 1/Rsch 3 qtrs	Process	F-workyear	
FLA3 Fac labor: Adj Teach 4 qtrs	Process	F-workyear	
Box TCH3 Teaching-laboratory classes	Process	F-workyear	B
Entry Links :			
FLA1 Fac labor: Tch 2/Rsch 2 qtrs	Process	F-workyear	
TVLD Handling Travel Orders &Claims	Process	Travl O/C	B
SUPL Handling P.O.'s for supplies	Process	S-workyear	B
CURR Maintain prof currency	Process	F-workyear	P
EXPM Laboratory experiments	Process	Experiment	BU
FLA2 Fac labor: Tch 1/Rsch 3 qtrs	Process	F-workyear	
FLA3 Fac labor: Adj Teach 4 qtrs	Process	F-workyear	
Box TVLD Handling Travel Orders &Claims	Process	Travl O/C	B
Entry Links :			
STAF Staff labor: ME dept & Code 34	Process	S-workyear	
SPLY Avg supplies/Purch Order	Supply	Supply-PO	
Box TYPE Editing asst/Research prep	Process	Proposal	U
Entry Links :			
STAF Staff labor: ME dept & Code 34	Process	S-workyear	

MODEL TITLE : NPS Mechanical Engineering Department Revision Three

	Box Type	Units	Tags
Box EMNT Avg equip/PC maint contract No Entry Links	Supply	Contract	
Box MATL Avg Lab materials No Entry Links	Supply	Materials	
Box SPLY Avg supplies/Purch Order No Entry Links	Supply	Supply-PO	
Box TOP Top of the model to be a link No Entry Links	Supply	Units	

**APPENDIX D. ATTRIBUTE TAGS BOX REPORT**

ATTRIBUTE TAGS BOX REPORT

MODEL TITLE : NPS Mechanical Engineering Department Revision Three  
SCENARIO: Master Model PERIOD # : 1 Year 1

=====  
Tag N Nonvalue added  
-----

Box Name	Type	Units
OTH2 Other Nonvalue Added Activity	Process	Workyear

Tag U Unit level activity  
-----

Box Name	Type	Units
RSCH Research	Process	F-workyear **
TYPE Editing asst/Research prep	Process	Proposal
EXPM Laboratory experiments	Process	Experiment

Tag B Batch level activity  
-----

Box Name	Type	Units
TCH1 Teaching-lecture classes	Process	F-workyear **
RSCH Research	Process	F-workyear **
EXPM Laboratory experiments	Process	Experiment **
SUPL Handling P.O.'s for supplies	Process	S-workyear
TVLD Handling Travel Orders &Claims	Process	Travl O/C
TCH2 Teaching-design classes	Process	F-workyear **
TCH3 Teaching-laboratory classes	Process	F-workyear **

Tag P Product level activity  
-----

Box Name	Type	Units
RSCH Research	Process	F-workyear
DEVM Course & Program Developmt	Process	F-workyear
CURR Maintain prof currency	Process	F-workyear **
PGMN Academic Program Maintenance	Process	F-workyear
AMGT Administrative Dept Mgt	Process	Workyear
MMGT NavEng Curricular Mgt	Process	Workyear

Tag F Facility level activity  
-----

Box Name	Type	Units
FACL Utilities & Telephone usage	Process	Usage

**APPENDIX E. MULTIPLIER REPORT**

MODEL TITLE : NPS Mechanical Engineering Department Revision Three

=====

Multiplier #1

-----

Process Box FLA1 Fac labor: Tch 2/Rsch 2 qtrs  
Category 101 Faculty O&M,N labor costs  
Category 102 Faculty RR labor costs

Multiplier #2

-----

Process Box FLA2 Fac labor: Tch 1/Rsch 3 qtrs  
Category 101 Faculty O&M,N labor costs  
Category 102 Faculty RR labor costs

Multiplier #3

-----

Process Box FLA3 Fac labor: Adj Teach 4 qtrs  
Category 101 Faculty O&M,N labor costs  
Category 102 Faculty RR labor costs  
Process Box FLA4 Fac labor: Adj Rsch 4 qtrs  
Category 101 Faculty O&M,N labor costs  
Category 102 Faculty RR labor costs

Multiplier Civ#

-----

Process Box STAF Staff labor: ME dept & Code 34  
Category 110 Staff O&MN labor: ME & Code 34  
Category 111 Staff RR labor: ME & Code 34

**APPENDIX F. FLOW AND UNIT COST REPORTS**

NPS Mechanical Engineering Department Revision Three

Scenario Master Model  
Period #1 Year 1

Mar 09 1995

Scenario Results  
Flow-Unit Cost

List of Demand Boxes Where :

Total Boxes in Model 35  
Available 3

ID	Box Name	Flow	Units	Unit Total Cost
AVST	Average on Board Students	100.00	AOBStudent	20703.8738
RESR	Research Products	48.00	Rsrch Prod	25575.4036
SPT	Support-nonvalue to ME dept	3.70	Workyear	82230.2185

NPS Mechanical Engineering Department Revision Three

Scenario Master Model  
Period #1 Year 1

Mar 09 1995

Scenario Results  
Costs

List of Demand Boxes Where :

Total Boxes in Model 35  
Available 3

ID	Box Name	Fixed Cost	Variable Cost	Total Cost
AVST	Average on Board Students	1995630.25	74757.13	2070387.38
RESR	Research Products	1167040.38	60579.00	1227619.38
SPT	Support-nonvalue to ME dept	304251.81	0.00	304251.81

NPS Mechanical Engineering Department Revision Three

Scenario Master Model  
Period #1 Year 1

Mar 09 1995

Scenario Results  
Flow-Unit Cost

List of Route Boxes Where :

Total Boxes in Model 35  
Available 2

ID	Box Name	Flow	Units	Unit Total Cost
DEC1	How many students vs thesis?	100.00	AOBStudent	20703.8738
DEC2	How many workyears/class type	11.28	F-workyear	135487.7809

NPS Mechanical Engineering Department Revision Three

Scenario Master Model  
Period #1 Year 1

Mar 09 1995

Scenario Results  
Flow-Unit Cost

List of Process Boxes Where :

Total Boxes in Model 35  
Available 26

ID	Box Name	Flow	Units	Unit Total Cost
AMGT	Administrative Dept Mgt	2.00	Workyear	79991.6797
AOBS	Students-Average On Board	88.00	AOBStudent	17711.6924
AOBT	Thesis Students-Avg On Board	12.00	AOBStudent	42646.5322
CURR	Maintain prof currency	0.79	F-workyear	64851.6259
DEVM	Course & Program Developmt	0.10	F-workyear	133770.2910
EQPT	Equipment for Labs (avg)	30.98	Equipment	4868.7507
EXPM	Laboratory experiments	15.49	Experiment	42767.6538
FACL	Utilities & Telephone usage	39.55	Usage	4960.9237
FLA1	Fac labor: Tch 2/Rsch 2 qtrs	12.29	F-workyear	102054.5696
FLA2	Fac labor: Tch 1/Rsch 3 qtrs	4.01	F-workyear	113107.8105
FLA3	Fac labor: Adj Teach 4 qtrs	3.95	F-workyear	87296.9927
FLA4	Fac labor: Adj Rsch 4 qtrs	3.02	F-workyear	112761.8031
MLAB	Military Labor	2.00	M-workyear	74155.5515
MMGT	NavEng Curricular Mgt	1.80	Workyear	63278.8645
OTH2	Other Nonvalue Added Activity	3.70	Workyear	82230.2185
PGMN	Academic Program Maintenance	0.06	F-workyear	8173.3543
RSCH	Research	9.08	F-workyear	159071.7478
STAF	Staff labor: ME dept & Code 34	14.27	S-workyear	52402.1748
SUMR	Summary for Research Products	48.00	Rsrch Prod	25575.4036
SUMS	Summary for Support/nonvalue	3.70	Workyear	82230.2185
SUPL	Handling P.O.'s for supplies	1.04	S-workyear	64902.1755
TCH1	Teaching-lecture classes	3.76	F-workyear	112678.3705
TCH2	Teaching-design classes	3.76	F-workyear	146892.4943
TCH3	Teaching-laboratory classes	3.76	F-workyear	146892.5031
TVLD	Handling Travel Orders &Claims	59.57	Travl O/C	3070.6253
TYPE	Editing asst/Research prep	4.80	Proposal	10480.4350

NPS Mechanical Engineering Department Revision Three

Scenario Master Model  
 Period #1 Year 1

Mar 09 1995

Scenario Results  
 Costs

List of Process Boxes Where :

Total Boxes in Model 35  
 Available 26

ID	Box Name	Fixed Cost	Variable Cost	Total Cost
AMGT	Administrative Dept Mgt	159983.36	0.00	159983.36
AOBS	Students-Average On Board	1502822.25	55806.68	1558628.93
AOBT	Thesis Students-Avg On Board	492807.94	18950.45	511758.39
CURR	Maintain prof currency	47392.48	3814.36	51206.84
DEVM	Course & Program Developmt	13377.03	0.00	13377.03
EQPT	Equipment for Labs (avg)	57893.00	92938.56	150831.56
EXPM	Laboratory experiments	539491.38	122969.34	662460.71
FACL	Utilities & Telephone usage	196186.00	0.00	196186.00
FLA1	Fac labor: Tch 2/Rsch 2 qtrs	1254608.63	0.00	1254608.63
FLA2	Fac labor: Tch 1/Rsch 3 qtrs	453954.50	0.00	453954.50
FLA3	Fac labor: Adj Teach 4 qtrs	345147.06	0.00	345147.06
FLA4	Fac labor: Adj Rsch 4 qtrs	340513.81	0.00	340513.81
MLAB	Military Labor	148117.92	0.00	148117.92
MMGT	NavEng Curricular Mgt	113901.95	0.00	113901.95
OTH2	Other Nonvalue Added Activity	304251.81	0.00	304251.81
PGMN	Academic Program Maintenance	488.90	1.50	490.40
RSCH	Research	1367818.00	76388.10	1444206.10
STAF	Staff labor: ME dept & Code 34	747696.50	0.00	747696.50
SUMR	Summary for Research Products	1167040.38	60579.00	1227619.38
SUMS	Summary for Support/nonvalue	304251.81	0.00	304251.81
SUPL	Handling P.O.'s for supplies	54610.67	13026.81	67637.49
TCH1	Teaching-lecture classes	419720.22	3950.45	423670.67
TCH2	Teaching-design classes	524485.56	27830.21	552315.78
TCH3	Teaching-laboratory classes	524485.56	27830.21	552315.78
TVLD	Handling Travel Orders &Claims	181420.34	1489.19	182909.53
TYPE	Editing asst/Research prep	50306.09	0.00	50306.09

NPS Mechanical Engineering Department Revision Three

Scenario Master Model  
Period #1 Year 1

Mar 09 1995

Scenario Results  
Flow-Unit Cost

List of Supply Boxes Where :

Total Boxes in Model 35  
Available 4

ID	Box Name	Flow	Units	Unit Total Cost
EMNT	Avg equip/PC maint contract	30.98	Contract	3000.0000
MATL	Avg Lab materials	15.49	Materials	1800.0000
SPLY	Avg supplies/Purch Order	5.81	Supply-PO	2500.0000
TOP	Top of the model to be a link	39.55	Units	0.0000



**APPENDIX G. DETAILED FLOWS RESULTS REPORT**

DETAILED FLOWS RESULTS REPORT

MODEL TITLE : NPS Mechanical Engineering Department Revision Three  
SCENARIO: Master Model PERIOD # : 1 Year 1

=====

BOX ID : AVST TYPE: Demand NAME: Average on Board Students  
VOLUME: 100.00 AOBStudent

ENTRY\_LINK BOXES  
INPUT FLOW

DEC1 Route How many students vs thesis? 100.00 AOBStudent

-----

BOX ID : RESR TYPE: Demand NAME: Research Products  
VOLUME: 48.00 Rsrch Prod

ENTRY\_LINK BOXES  
INPUT FLOW

SUMR Process Summary for Research Products 48.00 Rsrch Prod

-----

BOX ID : SPT TYPE: Demand NAME: Support-nonvalue to ME dept  
VOLUME: 3.70 Workyear

ENTRY\_LINK BOXES  
INPUT FLOW

SUMS Process Summary for Support/nonvalue 3.70 Workyear

-----

BOX ID : DEC1 TYPE: Route NAME: How many students vs thesis?  
OUTPUT FLOW: 100.00 AOBStudent

ENTRY\_LINK BOXES  
INPUT FLOW

AOBT Process Thesis Students-Avg On Board 12.00 AOBStudent  
AOBS Process Students-Average On Board 88.00 AOBStudent

-----

BOX ID : DEC2 TYPE: Route NAME: How many workyears/class type  
OUTPUT FLOW: 11.28 F-workyear

ENTRY\_LINK BOXES  
INPUT FLOW

TCH1 Process Teaching-lecture classes 3.76 F-workyear  
TCH2 Process Teaching-design classes 3.76 F-workyear  
TCH3 Process Teaching-laboratory classes 3.76 F-workyear

-----

BOX ID : AMGT TYPE: Process NAME: Administrative Dept Mgt  
OUTPUT FLOW: 2.00 Workyear

CAPACITY: 2.00 Workyear UTILIZATION: 100.00 %

ENTRY\_LINK BOXES  
INPUT FLOW

STAF Process Staff labor: ME dept & Code 34 1.00 S-workyear  
FLA1 Process Fac labor: Tch 2/Rsch 2 qtrs 0.50 F-workyear  
FLA2 Process Fac labor: Tch 1/Rsch 3 qtrs 0.50 F-workyear

-----

BOX ID : AOB S TYPE: Process NAME: Students-Average On Board  
OUTPUT FLOW: 88.00 AOBStudent

CAPACITY: 97.00 AOBStudent UTILIZATION: 90.72 %

ENTRY\_LINK BOXES  
INPUT FLOW

DEV M Process Course & Program Developmt 0.05 F-workyear  
MMGT Process NavEng Curricular Mgt 0.90 Workyear  
PGM Process Academic Program Maintenance 0.03 F-workyear  
DEC2 Route How many workyears/class type 10.56 F-workyear  
AMGT Process Administrative Dept Mgt 0.80 Workyear

-----

DETAILED FLOWS RESULTS REPORT

MODEL TITLE : NPS Mechanical Engineering Department Revision Three  
 SCENARIO: Master Model PERIOD # : 1 Year 1

=====

BOX ID : AOBT TYPE: Process NAME: Thesis Students-Avg On Board  
 OUTPUT FLOW: 12.00 AOBStudent  
 CAPACITY: 14.00 AOBStudent UTILIZATION: 85.71 %

ENTRY\_LINK BOXES INPUT FLOW

AMGT Process	Administrative Dept Mgt	0.80 Workyear
DEVM Process	Course & Program Developmt	0.05 F-workyear
MMGT Process	NavEng Curricular Mgt	0.90 Workyear
PGMN Process	Academic Program Maintenance	0.03 F-workyear
RSCH Process	Research	1.80 F-workyear
DEC2 Route	How many workyears/class type	0.72 F-workyear

-----

BOX ID : CURR TYPE: Process NAME: Maintain prof currency  
 OUTPUT FLOW: 0.79 F-workyear

ENTRY\_LINK BOXES INPUT FLOW

EXPM Process	Laboratory experiments	0.39 Experiment
TVLD Process	Handling Travel Orders &Claims	0.63 Travl O/C
RSCH Process	Research	0.08 F-workyear
FLA1 Process	Fac labor: Tch 2/Rsch 2 qtrs	0.07 F-workyear
FLA2 Process	Fac labor: Tch 1/Rsch 3 qtrs	0.07 F-workyear
FLA3 Process	Fac labor: Adj Teach 4 qtrs	0.07 F-workyear

-----

BOX ID : DEVM TYPE: Process NAME: Course & Program Developmt  
 OUTPUT FLOW: 0.10 F-workyear

ENTRY\_LINK BOXES INPUT FLOW

FLA1 Process	Fac labor: Tch 2/Rsch 2 qtrs	0.05 F-workyear
FLA2 Process	Fac labor: Tch 1/Rsch 3 qtrs	0.05 F-workyear
FLA3 Process	Fac labor: Adj Teach 4 qtrs	0.03 F-workyear

-----

BOX ID : EQPT TYPE: Process NAME: Equipment for Labs (avg)  
 OUTPUT FLOW: 30.98 Equipment

ENTRY\_LINK BOXES INPUT FLOW

EMNT Supply	Avg equip/PC maint contract	30.98 Contract
-------------	-----------------------------	----------------

-----

BOX ID : EXPM TYPE: Process NAME: Laboratory experiments  
 OUTPUT FLOW: 15.49 Experiment

CAPACITY: 20.00 Experiment UTILIZATION: 77.45 %

ENTRY\_LINK BOXES INPUT FLOW

STAF Process	Staff labor: ME dept & Code 34	7.74 S-workyear
EQPT Process	Equipment for Labs (avg)	30.98 Equipment
MLAB Process	Military Labor	0.90 M-workyear
SUPL Process	Handling P.O.'s for supplies	0.17 S-workyear
MATL Supply	Avg Lab materials	15.49 Materials

-----

BOX ID : FACL TYPE: Process NAME: Utilities & Telephone usage  
 OUTPUT FLOW: 39.55 Usage

ENTRY\_LINK BOXES INPUT FLOW

TOP Supply	Top of the model to be a link	39.55 Units
------------	-------------------------------	-------------

-----

DETAILED FLOWS RESULTS REPORT

MODEL TITLE : NPS Mechanical Engineering Department Revision Three  
 SCENARIO: Master Model PERIOD # : 1 Year 1

=====

BOX ID : FLA1 TYPE: Process NAME: Fac labor: Tch 2/Rsch 2 qtrs  
 OUTPUT FLOW: 12.29 F-workyear  
 CAPACITY: 12.50 F-workyear UTILIZATION: 98.35 %  
 ENTRY\_LINK BOXES INPUT FLOW  
 FACL Process Utilities & Telephone usage 12.29 Usage

-----

BOX ID : FLA2 TYPE: Process NAME: Fac labor: Tch 1/Rsch 3 qtrs  
 OUTPUT FLOW: 4.01 F-workyear  
 CAPACITY: 4.30 F-workyear UTILIZATION: 93.34 %  
 ENTRY\_LINK BOXES INPUT FLOW  
 FACL Process Utilities & Telephone usage 4.01 Usage

-----

BOX ID : FLA3 TYPE: Process NAME: Fac labor: Adj Teach 4 qtrs  
 OUTPUT FLOW: 3.95 F-workyear  
 CAPACITY: 4.00 F-workyear UTILIZATION: 98.84 %  
 ENTRY\_LINK BOXES INPUT FLOW  
 FACL Process Utilities & Telephone usage 3.95 Usage

-----

BOX ID : FLA4 TYPE: Process NAME: Fac labor: Adj Rsch 4 qtrs  
 OUTPUT FLOW: 3.02 F-workyear  
 CAPACITY: 3.30 F-workyear UTILIZATION: 91.51 %  
 ENTRY\_LINK BOXES INPUT FLOW  
 FACL Process Utilities & Telephone usage 3.02 Usage

-----

BOX ID : MLAB TYPE: Process NAME: Military Labor  
 OUTPUT FLOW: 2.00 M-workyear  
 CAPACITY: 2.00 M-workyear UTILIZATION: 99.87 %  
 ENTRY\_LINK BOXES INPUT FLOW  
 FACL Process Utilities & Telephone usage 2.00 Usage

-----

BOX ID : MGMT TYPE: Process NAME: NavEng Curricular Mgt  
 OUTPUT FLOW: 1.80 Workyear  
 CAPACITY: 2.00 Workyear UTILIZATION: 90.00 %  
 ENTRY\_LINK BOXES INPUT FLOW  
 MLAB Process Military Labor 0.90 M-workyear  
 STAF Process Staff labor: ME dept & Code 34 0.90 S-workyear

-----

BOX ID : OTH2 TYPE: Process NAME: Other Nonvalue Added Activity  
 OUTPUT FLOW: 3.70 Workyear  
 CAPACITY: 37.00 Workyear UTILIZATION: 10.00 %  
 ENTRY\_LINK BOXES INPUT FLOW  
 FLA1 Process Fac labor: Tch 2/Rsch 2 qtrs 1.09 F-workyear  
 FLA2 Process Fac labor: Tch 1/Rsch 3 qtrs 0.39 F-workyear  
 FLA3 Process Fac labor: Adj Teach 4 qtrs 0.30 F-workyear  
 FLA4 Process Fac labor: Adj Rsch 4 qtrs 0.30 F-workyear  
 STAF Process Staff labor: ME dept & Code 34 1.43 S-workyear  
 MLAB Process Military Labor 0.20 M-workyear

-----

DETAILED FLOWS RESULTS REPORT

MODEL TITLE : NPS Mechanical Engineering Department Revision Three  
SCENARIO: Master Model PERIOD # : 1 Year 1

BOX ID : PGMN TYPE: Process NAME: Academic Program Maintenance  
OUTPUT FLOW: 0.06 F-workyear  
ENTRY\_LINK BOXES INPUT FLOW  
FLA1 Process Fac labor: Tch 2/Rsch 2 qtrs 0.00 F-workyear  
TVLD Process Handling Travel Orders &Claims 0.06 Travl O/C

BOX ID : RSCH TYPE: Process NAME: Research  
OUTPUT FLOW: 9.08 F-workyear  
CAPACITY: 11.20 F-workyear UTILIZATION: 81.06 %  
ENTRY\_LINK BOXES INPUT FLOW  
FLA1 Process Fac labor: Tch 2/Rsch 2 qtrs 4.06 F-workyear  
FLA2 Process Fac labor: Tch 1/Rsch 3 qtrs 1.82 F-workyear  
FLA4 Process Fac labor: Adj Rsch 4 qtrs 2.72 F-workyear  
EXPM Process Laboratory experiments 9.08 Experiment  
SUPL Process Handling P.O.'s for supplies 0.27 S-workyear  
TVLD Process Handling Travel Orders &Claims 36.32 Travl O/C

BOX ID : STAF TYPE: Process NAME: Staff labor: ME dept & Code 34  
OUTPUT FLOW: 14.27 S-workyear  
CAPACITY: 14.50 S-workyear UTILIZATION: 98.40 %  
ENTRY\_LINK BOXES INPUT FLOW  
FACL Process Utilities & Telephone usage 14.27 Usage

BOX ID : SUMR TYPE: Process NAME: Summary for Research Products  
OUTPUT FLOW: 48.00 Rsrch Prod  
ENTRY\_LINK BOXES INPUT FLOW  
RSCH Process Research 7.20 F-workyear  
TYPE Process Editing asst/Research prep 4.80 Proposal  
AMGT Process Administrative Dept Mgt 0.40 Workyear

BOX ID : SUMS TYPE: Process NAME: Summary for Support/nonvalue  
OUTPUT FLOW: 3.70 Workyear  
ENTRY\_LINK BOXES INPUT FLOW  
OTH2 Process Other Nonvalue Added Activity 3.70 Workyear

BOX ID : SUPL TYPE: Process NAME: Handling P.O.'s for supplies  
OUTPUT FLOW: 1.04 S-workyear  
CAPACITY: 1.20 S-workyear UTILIZATION: 86.85 %  
ENTRY\_LINK BOXES INPUT FLOW  
SPLY Supply Avg supplies/Purch Order 5.21 Supply-PO  
STAF Process Staff labor: ME dept & Code 34 1.04 S-workyear

DETAILED FLOWS RESULTS REPORT

MODEL TITLE : NPS Mechanical Engineering Department Revision Three  
 SCENARIO: Master Model PERIOD # : 1 Year 1

=====

BOX ID : TCH1 TYPE: Process NAME: Teaching-lecture classes  
 OUTPUT FLOW: 3.76 F-workyear  
 CAPACITY: 3.76 F-workyear UTILIZATION: 100.00 %

ENTRY\_LINK BOXES INPUT FLOW

TVLD	Process	Handling Travel Orders &Claims	7.52	Travl O/C
SUPL	Process	Handling P.O.'s for supplies	0.20	S-workyear
CURR	Process	Maintain prof currency	0.26	F-workyear
FLA1	Process	Fac labor: Tch 2/Rsch 2 qtrs	2.18	F-workyear
FLA2	Process	Fac labor: Tch 1/Rsch 3 qtrs	0.40	F-workyear
FLA3	Process	Fac labor: Adj Teach 4 qtrs	1.19	F-workyear

-----

BOX ID : TCH2 TYPE: Process NAME: Teaching-design classes  
 OUTPUT FLOW: 3.76 F-workyear  
 CAPACITY: 3.76 F-workyear UTILIZATION: 100.00 %

ENTRY\_LINK BOXES INPUT FLOW

FLA1	Process	Fac labor: Tch 2/Rsch 2 qtrs	2.18	F-workyear
TVLD	Process	Handling Travel Orders &Claims	7.52	Travl O/C
SUPL	Process	Handling P.O.'s for supplies	0.20	S-workyear
CURR	Process	Maintain prof currency	0.26	F-workyear
EXPM	Process	Laboratory experiments	3.01	Experiment
FLA2	Process	Fac labor: Tch 1/Rsch 3 qtrs	0.40	F-workyear
FLA3	Process	Fac labor: Adj Teach 4 qtrs	1.19	F-workyear

-----

BOX ID : TCH3 TYPE: Process NAME: Teaching-laboratory classes  
 OUTPUT FLOW: 3.76 F-workyear  
 CAPACITY: 3.76 F-workyear UTILIZATION: 100.00 %

ENTRY\_LINK BOXES INPUT FLOW

FLA1	Process	Fac labor: Tch 2/Rsch 2 qtrs	2.18	F-workyear
TVLD	Process	Handling Travel Orders &Claims	7.52	Travl O/C
SUPL	Process	Handling P.O.'s for supplies	0.20	S-workyear
CURR	Process	Maintain prof currency	0.26	F-workyear
EXPM	Process	Laboratory experiments	3.01	Experiment
FLA2	Process	Fac labor: Tch 1/Rsch 3 qtrs	0.40	F-workyear
FLA3	Process	Fac labor: Adj Teach 4 qtrs	1.19	F-workyear

-----

BOX ID : TVLD TYPE: Process NAME: Handling Travel Orders &Claims  
 OUTPUT FLOW: 59.57 Travl O/C

ENTRY\_LINK BOXES INPUT FLOW

STAF	Process	Staff labor: ME dept & Code 34	1.19	S-workyear
SPLY	Supply	Avg supplies/Purch Order	0.60	Supply-PO

-----

BOX ID : TYPE TYPE: Process NAME: Editing asst/Research prep  
 OUTPUT FLOW: 4.80 Proposal

ENTRY\_LINK BOXES INPUT FLOW

STAF	Process	Staff labor: ME dept & Code 34	0.96	S-workyear
------	---------	--------------------------------	------	------------

-----

BOX ID : EMNT TYPE: Supply NAME: Avg equip/PC maint contract  
 OUTPUT FLOW: 30.98 Contract

-----

DETAILED FLOWS RESULTS REPORT

MODEL TITLE : NPS Mechanical Engineering Department Revision Three  
SCENARIO: Master Model PERIOD # : 1 Year 1

=====

BOX ID : MATL	TYPE: Supply	NAME: Avg Lab materials	
		OUTPUT FLOW:	15.49 Materials

-----

BOX ID : SPLY	TYPE: Supply	NAME: Avg supplies/Purch Order	
		OUTPUT FLOW:	5.81 Supply-PO

-----

BOX ID : TOP	TYPE: Supply	NAME: Top of the model to be a link	
		OUTPUT FLOW:	39.55 Units
CAPACITY:	1500000.00	Units	UTILIZATION: 0.00 %

-----



**APPENDIX H. TOTAL FINANCIAL RESULTS**

Scenario Master Model  
 Period #1 Year 1

Mar 09 1995  
 6:38 pm

Total Financial Results [\$]			
'NPS Mechanical Engineering Department Revision Three'			
Category	Fixed	Variable	Total
101 Faculty O&M,N labor costs	1483193.41	0.00	1483193.41
102 Faculty RR labor costs	795538.14	0.00	795538.14
103 Military labor: officer	98097.00	0.00	98097.00
104 Military labor: enlisted	40112.00	0.00	40112.00
110 Staff O&MN labor: ME & Code 34	653487.95	0.00	653487.95
111 Staff RR labor: ME & Code 34	23423.95	0.00	23423.95
<b>Total labor costs</b>	<b>3093852.47</b>	<b>0.00</b>	<b>3093852.47</b>
201 Reimb Rsch travel	89812.00	0.00	89812.00
202 Direct funded rsch travel	17297.00	0.00	17297.00
203 Indirect DFR travel	11680.00	0.00	11680.00
205 Code 07 managed travel	202.00	0.00	202.00
<b>Total travel costs</b>	<b>118991.00</b>	<b>0.00</b>	<b>118991.00</b>
301 New equipment costs (O&M,N)	18005.00	0.00	18005.00
302 Equipment maintenance	0.00	61959.04	61959.04
305 Computer maintenance	0.00	30979.52	30979.52
307 New equipment costs (OP,N)	39888.00	0.00	39888.00
<b>Total Equipment costs</b>	<b>57893.00</b>	<b>92938.56</b>	<b>150831.56</b>
401 Supplies for ME dept	0.00	14516.00	14516.00
402 Materials for experiments	0.00	27881.57	27881.57
<b>Total Supplies</b>	<b>0.00</b>	<b>42397.57</b>	<b>42397.57</b>
501 Long Distance charges	3000.00	0.00	3000.00
<b>Total Telephone charges</b>	<b>3000.00</b>	<b>0.00</b>	<b>3000.00</b>
601 Utilities charges allocated	193186.00	0.00	193186.00
<b>Total Utilities charges</b>	<b>193186.00</b>	<b>0.00</b>	<b>193186.00</b>
<b>Total Cost</b>	<b>3466922.47</b>	<b>135336.13</b>	<b>3602258.60</b>

+--- Total Model Summary ---+			
	Fixed	Variable	Total
Cost	3466922.47	135336.13	3602258.60

**APPENDIX I. FINANCIAL RESULTS BY COST CATEGORY**

CATEGORY BREAKDOWN REPORT [\$]

MODEL TITLE : NPS Mechanical Engineering Department Revision Three  
 SCENARIO: Master Model PERIOD # : 1 Year 1

=====

CATEGORY: 101 Faculty O&M,N labor costs

BOX	TYPE	NAME	\$DATA	QTY	UNITS	TOTAL	%
FLA1	Process	Fac labor: Tch 2/Rsc	776913.41F	12.29	F-workyear	776913.41	52.38
FLA2	Process	Fac labor: Tch 1/Rsc	282512.00F	4.01	F-workyear	282512.00	19.05
FLA3	Process	Fac labor: Adj Teach	211884.00F	3.95	F-workyear	211884.00	14.29
FLA4	Process	Fac labor: Adj Rsch	211884.00F	3.02	F-workyear	211884.00	14.29
						-----	-----
						1483193.41	100.00

-----

CATEGORY: 102 Faculty RR labor costs

BOX	TYPE	NAME	\$DATA	QTY	UNITS	TOTAL	%
FLA1	Process	Fac labor: Tch 2/Rsc	416708.14F	12.29	F-workyear	416708.14	52.38
FLA2	Process	Fac labor: Tch 1/Rsc	151532.00F	4.01	F-workyear	151532.00	19.05
FLA3	Process	Fac labor: Adj Teach	113649.00F	3.95	F-workyear	113649.00	14.29
FLA4	Process	Fac labor: Adj Rsch	113649.00F	3.02	F-workyear	113649.00	14.29
						-----	-----
						795538.14	100.00

-----

CATEGORY: 103 Military labor: officer

BOX	TYPE	NAME	\$DATA	QTY	UNITS	TOTAL	%
MLAB	Process	Military Labor	98097.00F	2.00	M-workyear	98097.00	100.00

-----

CATEGORY: 104 Military labor: enlisted

BOX	TYPE	NAME	\$DATA	QTY	UNITS	TOTAL	%
MLAB	Process	Military Labor	40112.00F	2.00	M-workyear	40112.00	100.00

-----

CATEGORY: 110 Staff O&MN labor: ME & Code 34

BOX	TYPE	NAME	\$DATA	QTY	UNITS	TOTAL	%
STAF	Process	Staff labor: ME dept	653487.95F	14.27	S-workyear	653487.95	100.00

-----

CATEGORY BREAKDOWN REPORT [\$]

MODEL TITLE : NPS Mechanical Engineering Department Revision Three  
 SCENARIO: Master Model PERIOD # : 1 Year 1

=====

CATEGORY: 111 Staff RR labor: ME & Code 34

BOX TYPE	NAME	\$DATA	QTY	UNITS	TOTAL	%
STAF Process	Staff labor: ME dept	23423.95F	14.27	S-workyear	23423.95	100.00

-----

CATEGORY: 201 Reimb Rsch travel

BOX TYPE	NAME	\$DATA	QTY	UNITS	TOTAL	%
TVLD Process	Handling Travel Orde	89812.00F	59.57	Travl O/C	89812.00	100.00

-----

CATEGORY: 202 Direct funded rsch travel

BOX TYPE	NAME	\$DATA	QTY	UNITS	TOTAL	%
TVLD Process	Handling Travel Orde	17297.00F	59.57	Travl O/C	17297.00	100.00

-----

CATEGORY: 203 Indirect DFR travel

BOX TYPE	NAME	\$DATA	QTY	UNITS	TOTAL	%
TVLD Process	Handling Travel Orde	11680.00F	59.57	Travl O/C	11680.00	100.00

-----

CATEGORY: 205 Code 07 managed travel

BOX TYPE	NAME	\$DATA	QTY	UNITS	TOTAL	%
TVLD Process	Handling Travel Orde	202.00F	59.57	Travl O/C	202.00	100.00

-----

CATEGORY: 301 New equipment costs (O&M,N)

BOX TYPE	NAME	\$DATA	QTY	UNITS	TOTAL	%
EQPT Process	Equipment for Labs (	18005.00F	30.98	Equipment	18005.00	100.00

-----

CATEGORY: 302 Equipment maintenance

BOX TYPE	NAME	\$DATA	QTY	UNITS	TOTAL	%
EMNT Supply	Avg equip/PC maint c	2000.00V	30.98	Contract	61959.04	100.00

-----

CATEGORY BREAKDOWN REPORT [\$]

MODEL TITLE : NPS Mechanical Engineering Department Revision Three  
 SCENARIO: Master Model PERIOD # : 1 Year 1

=====

CATEGORY: 305 Computer maintenance

BOX	TYPE	NAME	\$DATA	QTY	UNITS	TOTAL	%
EMNT	Supply	Avg equip/PC maint c	1000.00V	30.98	Contract	30979.52	100.00

-----

CATEGORY: 307 New equipment costs (OP,N)

BOX	TYPE	NAME	\$DATA	QTY	UNITS	TOTAL	%
EQPT	Process	Equipment for Labs (	39888.00F	30.98	Equipment	39888.00	100.00

-----

CATEGORY: 401 Supplies for ME dept

BOX	TYPE	NAME	\$DATA	QTY	UNITS	TOTAL	%
SPLY	Supply	Avg supplies/Purch O	2500.00V	5.81	Supply-PO	14516.00	100.00

-----

CATEGORY: 402 Materials for experiments

BOX	TYPE	NAME	\$DATA	QTY	UNITS	TOTAL	%
MATL	Supply	Avg Lab materials	1800.00V	15.49	Materials	27881.57	100.00

-----

CATEGORY: 501 Long Distance charges

BOX	TYPE	NAME	\$DATA	QTY	UNITS	TOTAL	%
FACL	Process	Utilities & Telephon	3000.00F	39.55	Usage	3000.00	100.00

-----

CATEGORY: 601 Utilities charges allocated

BOX	TYPE	NAME	\$DATA	QTY	UNITS	TOTAL	%
FACL	Process	Utilities & Telephon	193186.00F	39.55	Usage	193186.00	100.00

-----

## INITIAL DISTRIBUTION LIST

	No. Copies
1. Defense Technical Information Center Cameron Station Alexandria, Virginia 22304-6145	2
2. Library, Code 52 Naval Postgraduate School Monterey, California 93943-5101	2
3. Director, Training and Education MCCDC, Code C46 1019 Elliot Rd. Quantico, VA 22134-5027	1
4. Professor Kenneth J. Euske Code SM/Ee Naval Postgraduate School Monterey, CA 93943	3
5. Professor James M. Fremgen Code SM/Fm Naval Postgraduate School Monterey, CA 93943	1
6. Professor Matthew D. Kelleher Code ME/Kk Naval Postgraduate School Monterey, CA 93943	1
7. Professor David Whipple Code SM/Wp Naval Postgraduate School Monterey, CA 93943	1

- |     |  |   |
|-----|--|---|
| 8.  | Professor Reuben Harris<br>Code SM/Hr<br>Naval Postgraduate School<br>Monterey, CA 93943   | 1 |
| 9.  | Professor Dan Boger<br>Code SM/Bo<br>Naval Postgraduate School<br>Monterey, CA 93943   | 1 |
| 10. | Professor Richard Elster<br>Code SM/EI<br>Naval Postgraduate School<br>Monterey, CA 93943  | 1 |
| 11. | Mr. Robert Jay<br>Comptroller<br>Naval Postgraduate School<br>Monterey, CA 93943   | 1 |
| 12. | LtCol William C. Johnson, USMC<br>United States Marine Corps Representative<br>Naval Postgraduate School, Code 037<br>Monterey, CA 93943 | 1 |
| 13. | Professor Emeritus Evelyn Belgum<br>2173 Oak Creek Place<br>Hayward, California 94541-5535   | 1 |
| 14. | Professor Emeritus Loretta Belgum<br>3375 Tice Creek Drive<br>Walnut Creek, California 94595   | 1 |
| 15. | First Lieutenant Guner Gursoy<br>Kilavuzcayiricad Akpinar<br>Apt. number 20/8<br>Kucukyali, Istanbul<br>TURKEY                           | 1 |
| 16. | Captain Stephen A. Belgum, USMC<br>376 Watson Street, Apt A<br>Monterey, CA 93940-2289   | 2 |