

ARMY RESEARCH LABORATORY



# Feasibility Study on Producing Chaotic Signals

by Neal Tesny and  
Andrea K. Mark

ARL-MR-215

August 1995

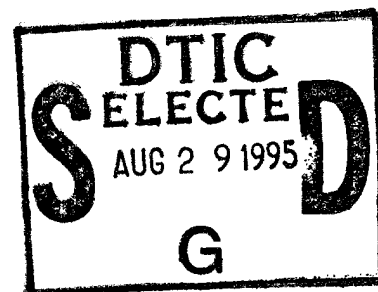

19950822 013

Approved for public release; distribution unlimited.

The findings in this report are not to be construed as an official Department of the Army position unless so designated by other authorized documents.

Citation of manufacturer's or trade names does not constitute an official endorsement or approval of the use thereof.

Destroy this report when it is no longer needed. Do not return it to the originator.

<b>REPORT DOCUMENTATION PAGE</b>			<i>Form Approved OMB No. 0704-0188</i>	
Public reporting burden for this collection of information is estimated to average 1 hour per response, including the time for reviewing instructions, searching existing data sources, gathering and maintaining the data needed, and completing and reviewing the collection of information. Send comments regarding this burden estimate or any other aspect of this collection of information, including suggestions for reducing this burden, to Washington Headquarters Services, Directorate for Information Operations and Reports, 1215 Jefferson Davis Highway, Suite 1204, Arlington, VA 22202-4302, and to the Office of Management and Budget, Paperwork Reduction Project (0704-0188), Washington, DC 20503.				
<b>1. AGENCY USE ONLY</b> <i>(Leave blank)</i>		<b>2. REPORT DATE</b> August 1995	<b>3. REPORT TYPE AND DATES COVERED</b> Final, from 7/93 to 12/93	
<b>4. TITLE AND SUBTITLE</b> Feasibility Study on Producing Chaotic Signals			<b>5. FUNDING NUMBERS</b> PE: 62120	
<b>6. AUTHOR(S)</b> Neal Tesny and Andrea K. Mark				
<b>7. PERFORMING ORGANIZATION NAME(S) AND ADDRESS(ES)</b> U.S. Army Research Laboratory Attn: AMSRL-WT-NF 2800 Powder Mill Road Adelphi, MD 20783-1197			<b>8. PERFORMING ORGANIZATION REPORT NUMBER</b> ARL-MR-215	
<b>9. SPONSORING/MONITORING AGENCY NAME(S) AND ADDRESS(ES)</b> U.S. Army Research Laboratory 2800 Powder Mill Road Adelphi, MD 20783-1197			<b>10. SPONSORING/MONITORING AGENCY REPORT NUMBER</b>	
<b>11. SUPPLEMENTARY NOTES</b> AMS code: 622120.H250011 ARL proj no: 5FE425				
<b>12a. DISTRIBUTION/AVAILABILITY STATEMENT</b> Approved for public release; distribution unlimited.			<b>12b. DISTRIBUTION CODE</b>	
<b>13. ABSTRACT</b> <i>(Maximum 200 words)</i> An investigation was conducted to determine if chaotic effects produced from filter-limiter circuits could be used to create wideband signals. The tests involved power levels varying from 1 W up to the kilowatt level, with frequency bands from L- through X-band.				
<b>14. SUBJECT TERMS</b> Chaotic, wideband			<b>15. NUMBER OF PAGES</b> 15	
			<b>16. PRICE CODE</b>	
<b>17. SECURITY CLASSIFICATION OF REPORT</b> Unclassified	<b>18. SECURITY CLASSIFICATION OF THIS PAGE</b> Unclassified	<b>19. SECURITY CLASSIFICATION OF ABSTRACT</b> Unclassified	<b>20. LIMITATION OF ABSTRACT</b> UL	

# Contents

Introduction .....	5
Background .....	5
Approach .....	5
Filter-Limiter Circuit Description .....	6
Experimental Results .....	6
Conclusion .....	9
Bibliography .....	9
Appendix.—Tabulated Data of Perturbations versus Frequency versus Power .....	11

## Figures

1. Measurement setup .....	5
2. Response of the filter-limiter .....	6
3. Response of the filter-limiter in a chaotic state .....	7

## Table

1. Measured efficiencies .....	8
--------------------------------	---

Accession For	
NTIS CRA&I	<input checked="" type="checkbox"/>
DTIC TAB	<input type="checkbox"/>
Unannounced	<input type="checkbox"/>
Justification	
By	
Distribution /	
Availability Codes	
Dist	Avail and/or Special
A-1	

DTIC QUALITY INSPECTED 6

## Introduction

An effort to study the feasibility of producing chaotic signals was initiated in response to the results of a phenomenon observed by Glenn et al during a filter-limiter circuit experiment.<sup>1</sup> The filter was seen to go into a chaotic state when exposed to power levels over a certain threshold. This resulted in a wideband signal, produced at the output of the filter-limiter circuit. This result prompted the idea of exploiting the chaotic phenomena in filter-limiter circuits to produce ultra-wideband (UWB) signals at high power levels.

## Background

Chaos defies a precise definition. To an untrained observer, chaos is often mistaken as noise. Chaos is a type of random process that produces a broad-based power spectral density; this is why it can be erroneously viewed as noise. In electronic systems, chaotic behavior can be expected to occur in a wide variety of nonlinear devices. It can occur in very simple circuits such as an RLC circuit with a nonlinear diode. The occurrence of chaotic effects becomes more probable as devices are driven to higher efficiencies and power levels.

## Approach

In these experiments, we connected the filter-limiter in a circuit and observed the effects produced at the output as the input power was varied. The test setup is shown in figure 1. The first experiment was aimed at reproducing the chaotic states observed by Glenn et al at low power levels. Then the power levels were increased to determine the feasibility of exploiting chaos in filter-limiter circuits to produce UWB signals. Operating parameters were determined and optimized, including efficiency, frequency, UWB power, etc. Finally, other types of devices were investigated for chaotic behavior.

Figure 1.  
Measurement setup.

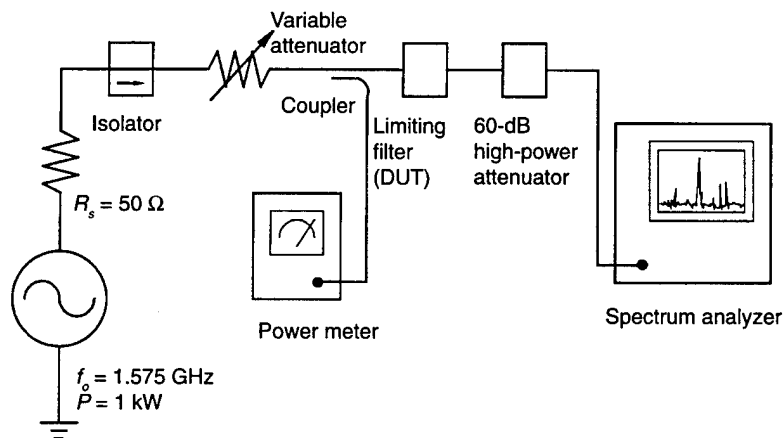

<sup>1</sup> Chance M. Glenn, Scott Hayes, Robert J. Tan, and Roger Kaul, Chaos in a Microwave Limiter Circuit, Army Research Laboratory, ARL-TR-26 (September 1993).

## Filter-Limiter Circuit Description

The filter-limiter circuit is a narrowband filter into which a 10-W PIN diode is inserted to cause nonlinear limiting. The response of the filter is shown in figure 2.

## Experimental Results

We repeated Glenn et al's experiment<sup>1</sup> with the filter-limiter circuit at the milliwatt level. We connected the filter-limiter to a power source, put a signal of about 100 mW into it, and observed the output of the filter-limiter on an oscilloscope. This was configured on the  $x$ - $y$  inputs, with the  $x$ -line delayed with a delay line. This is the classic setup for detecting chaos. Also, we connected a spectrum analyzer to the output of the filter-limiter circuit to observe what frequencies it produces. The frequency used here was 1.575 GHz, which is in the filter's passband. The input signal level to the filter-limiter circuit was slowly varied and the response observed. We saw that by increasing the power into the filter-limiter circuit, different stages of chaos were produced. This agreed with the results seen by Glenn et al.<sup>1</sup> Figure 3 shows the response of the filter-limiter circuit when it entered the chaotic state. Note that a continuous spectrum (UWB) of frequencies is generated when it is in the chaotic state.

**Figure 2.**  
Response of the  
filter-limiter.

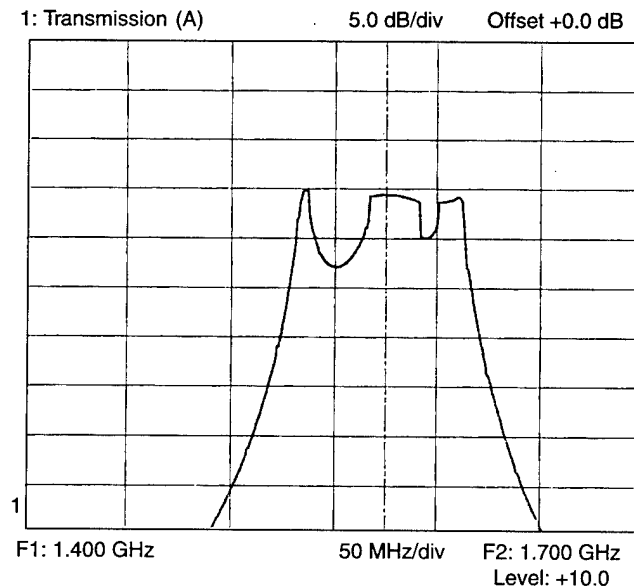

<sup>1</sup>Chance M. Glenn, Scott Hayes, Robert J. Tan, and Roger Kaul, Chaos in a Microwave Limiter Circuit, Army Research Laboratory, ARL-TR-26 (September 1993).

**Figure 3. Response of the filter-limiter in a chaotic state.**

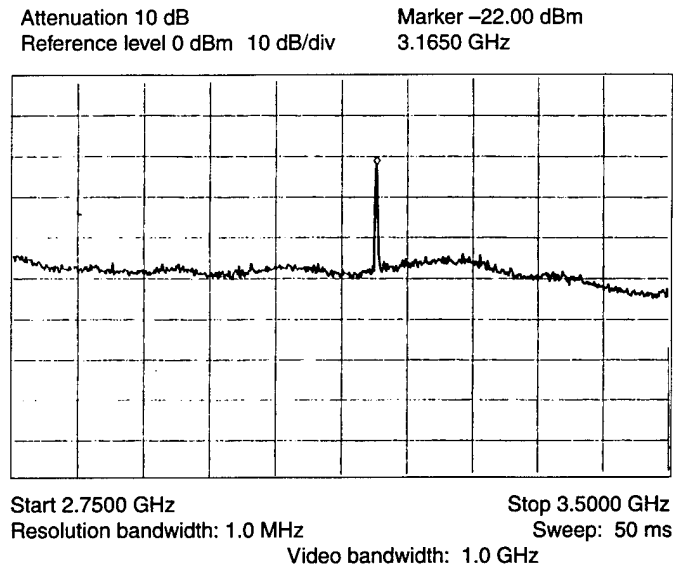

We measured periods and chaos versus power and frequency. Here, the  $x$  and  $y$  inputs to a Tektronix 7104 oscilloscope were used. The output of the filter-limiter circuit was connected to the  $x$  and  $y$  inputs of the oscilloscope, with a delay line in front of the  $y$  input. The input power to the filter-limiter circuit was set at a certain level. The frequency range was then swept through from 1.62 to 1.50 GHz. Periodicities and bifurcations were noted, as well as the frequencies at which they occurred. These data are given in the appendix.

We tried gas limiters at the kilowatt level and saw no chaotic effects. The limiter used was a Westinghouse GaAs gas limiter, connected with a commercial filter in the same setup as in the first two steps. The microwave source was pulsed over a bandwidth from 2.5 to 4.0 GHz. No chaotic effects were observed.

Terminal protection devices (TPDs) were also investigated and no chaotic behavior was seen. These devices were tested in the same setup. A commercial filter was placed in line with the TPD to provide the reactive element; the TPD would provide the nonlinear element. A low-pass filter with a cutoff of 2 GHz and a bandpass filter of 2 to 4 GHz were used.

We also investigated a higher power diode at the kilowatt level in conjunction with a commercial filter. The diode was connected in the circuit with a commercial filter. The diode was mounted on a bulkhead and placed separately in the circuit. The power levels used were around 1 kW, and several frequencies between 2.5 and 7 GHz were used. The duty cycle was slightly lower than 10 percent. Commercial bandpass filters were placed in line after the diode. The frequency of the source was set near the cutoff frequency of the filter. This frequency was set near the filter cutoff frequency in order to facilitate the production of chaotic behavior. No chaotic effects were observed with this setup.

We replaced the diode in the Glenn et al filter-limiter circuit with a high-power diode. We tested at the watt level using the same setup as in the original procedure. The diode used here was rated at 200 W. We did not observe any chaos or period doubling in this test circuit. Then we put the original type of diode back in the filter and took efficiency measurements. The efficiencies were not promising: ~1 percent. Power fed into the filter-limiter circuit was measured using a power meter, along with power output from the filter-limiter circuit when it entered the chaotic state. The ratio  $P_{out}/P_{in}$  was designated as the efficiency. The results of these measurements are listed in table 1. Then we detuned the filter; i.e., we took the diode out and placed it on a quarter-wavelength stub. This was placed right in front of the filter. No chaos or period doubling was seen.

**Table 1. Measured efficiencies.**

$P_{in}$ (dB)	$P_{in}$ (W)	$P_{out}$ (dB)	$P_{out}$ (W)	$P_{fund}$ (dB)	$P_{fund}$ (W)	$E_1$ (%)	$E_2$ (%)
31.40	$1.38 \times 10$	11.40	$1.38 \times 10^{-2}$	4.50	$2.81 \times 10^{-3}$	1.00	0.80
32.60	$1.81 \times 10$	7.60	$5.75 \times 10^{-3}$	-8.50	$1.41 \times 10^{-4}$	0.32	0.31
36.40	$4.36 \times 10$	0.90	$1.23 \times 10^{-3}$	-7.00	$1.99 \times 10^{-4}$	0.03	0.02
29.00	$7.94 \times 10^{-1}$	7.00	$5.01 \times 10^{-3}$	-12.50	$5.62 \times 10^{-5}$	0.63	0.62
31.60	$1.44 \times 10$	11.00	$1.25 \times 10^{-2}$	5.00	$3.16 \times 10^{-3}$	0.87	0.65
33.80	$2.39 \times 10$	13.40	$2.18 \times 10^{-2}$	8.83	$7.63 \times 10^{-3}$	0.91	0.59
33.98	$2.50 \times 10$	13.02	$2.00 \times 10^{-2}$	10.00	$1.00 \times 10^{-2}$	0.80	0.40
30.60	$1.14 \times 10$	17.60	$5.75 \times 10^{-2}$	7.80	$6.02 \times 10^{-3}$	5.01	4.49
29.40	$8.70 \times 10^{-1}$	11.10	$1.28 \times 10^{-2}$	4.50	$2.81 \times 10^{-3}$	1.48	1.16
38.00	$6.30 \times 10$	15.00	$3.16 \times 10^{-2}$	-12.00	$1.58 \times 10^{-2}$	0.50	0.25
33.00	$1.99 \times 10$	13.20	$2.08 \times 10^{-2}$	7.50	$5.62 \times 10^{-3}$	1.05	0.77
31.40	$1.38 \times 10$	12.50	$1.77 \times 10^{-2}$	6.70	$4.67 \times 10^{-3}$	1.29	0.95
17.40	$5.49 \times 10^{-2}$	-9.50	$1.12 \times 10^{-4}$	—	—	0.20	—
18.80	$7.58 \times 10^{-2}$	3.50	$2.23 \times 10^{-3}$	—	—	2.95	—
20.40	$1.09 \times 10^{-1}$	8.33	$6.80 \times 10^{-3}$	—	—	6.21	—
22.80	$1.90 \times 10^{-1}$	12.67	$1.84 \times 10^{-2}$	—	—	9.71	—
25.60	$3.63 \times 10^{-1}$	16.17	$4.13 \times 10^{-2}$	—	—	11.40	—
28.60	$7.24 \times 10^{-1}$	19.33	$8.57 \times 10^{-2}$	—	—	11.83	—
31.20	$1.31 \times 10$	22.33	$1.71 \times 10^{-1}$	—	—	12.97	—
33.80	$2.39 \times 10$	24.83	$3.04 \times 10^{-1}$	—	—	12.68	—
36.20	$4.16 \times 10$	27.17	$5.21 \times 10^{-1}$	—	—	12.50	—

$P_{in}$  = Power input to filter-limiter

$P_{out}$  = Power output from filter-limiter

$P_{fund}$  = Power of fundamental frequency output from filter-limiter as measured on spectrum analyzer

$E_1 = P_{out}/P_{in}$

$E_2 = (P_{out} - P_{fund})/P_{in}$

## Conclusion

Chaotic behavior was observed in a filter-limiter circuit using a PIN diode limiter located at the rear of a line-type filter. Chaos occurred at the milliwatt power level. However, when a new diode was inserted for operation at the kilowatt level, no chaos was observed. Other nonlinear circuits were investigated and chaos was not observed.

UWB signals were generated in the chaotic mode by the use of filter-limiter circuits, but the efficiencies were only about 1 percent. Our attempts to exploit this chaotic phenomenon to induce high-power UWB signals were not successful. Our investigation should be considered preliminary. Nonlinear devices such as varactors, opto-electronic limiters, and spark-gaps were not investigated. However, it appears that nonlinear devices/circuits that cause the input signal to pass through unattenuated would be required to increase the efficiency, unlike the limiter-filter circuits investigated here, where most of the input signal is reflected in the operating mode. Perhaps matched circuits would be an area for future work.

## Bibliography

Glenn, Chance M., Scott Hayes, Robert J. Tan, and Roger Kaul, *Chaos in a Microwave Limiter Circuit*, Army Research Laboratory, ARL-TR-26 (September 1993).

Gleick, James, *Chaos*, Viking Penguin Inc. (1987).

## Appendix.—Tabulated Data of Perturbations versus Frequency versus Power

Periods and chaos versus power and frequency were measured. The output of the filter-limiter was connected to a spectrum analyzer and to the  $x$  and  $y$  inputs of the oscilloscope, with a delay line in front of the  $y$  input. The input power to the filter-limiter was set to a specific level. The frequency range was then swept through from 1.62 to 1.50 GHz. Periodicities and bifurcations produced at the output of the filter-limiter and the frequencies at which they occurred were noted.

The number shown in the second column represents the period doubling, quadrupling, etc, of the output signal. A "C" indicates that the output entered a chaotic state.

Frequency (GHz)	Bifurcations $P_{in} = 27$ dBm
1.62	1
1.6121	2
1.6105	4
1.6101	8
1.6098	6
1.6086	C
1.6082	6
1.6074	C
1.5334	6
1.5328	C
1.5256	7
1.5244	C
1.5229	6
1.5227	C
1.5065	6
1.5058	3
1.5043	4
1.5041	2
1.4974	1

Frequency (GHz)	Bifurcations $P_{in} = 25$ dBm
1.6200	1
1.6107	2
1.6092	4
1.6089	6
1.6084	C
1.6074	6
1.6072	C
1.5093	6
1.5090	3
1.5074	4
1.5073	2
1.5014	1

Frequency (GHz)	Bifurcations $P_{in} = 24$ dBm
1.6200	1
1.6102	2
1.6087	4
1.6085	8
1.6080	C
1.6068	6
1.6064	C
1.5867	7
1.5861	C
1.5595	7
1.5592	C
1.5095	6
1.5092	3
1.5078	4
1.5076	2
1.5022	1

Frequency (GHz)	Bifurcations $P_{in} = 23$ dBm
1.6200	1
1.6093	2
1.6081	4
1.6075	6
1.6073	C
1.6071	8
1.6069	C
1.6064	6
1.6060	C
1.5268	12
1.5264	C
1.5174	3
1.5169	C
1.5102	6
1.5097	3
1.5081	4
1.5080	2
1.5031	1

Frequency (GHz)	Bifurcations $P_{in} = 22$ dBm
1.6200	1
1.6086	2
1.6075	4
1.6072	6
1.6068	C
1.6058	6
1.6055	C
1.5604	7
1.5601	C
1.5109	3
1.5088	8
1.5086	4
1.5084	2
1.5035	1

Frequency (GHz)	Bifurcations $P_{in} = 21$ dBm
1.6200	1
1.6083	2
1.6071	4
1.6068	6
1.6065	C
1.6063	8
1.6062	C
1.6056	6
1.6055	C
1.5772	8
1.5755	4
1.5717	C
1.5474	12
1.5472	6
1.5415	12

# Appendix

Frequency (GHz)	Bifurcations $P_{in} = 21$ dBm
1.5408	C
1.5122	6
1.5114	3
1.5094	4
1.5088	2
1.5038	1

Frequency (GHz)	Bifurcations $P_{in} = 20$ dBm
1.6200	1
1.6073	2
1.6060	6
1.6055	8
1.6053	C
1.6049	6
1.6046	C
1.5800	8
1.5796	4
1.5785	C
1.5513	6
1.5507	3
1.5378	6
1.5366	C
1.5180	12
1.5176	6
1.5162	3
1.5110	4
1.5107	2
1.5046	1

Frequency (GHz)	Bifurcations $P_{in} = 19$ dBm
1.6200	1
1.6069	2
1.6056	6
1.6053	8
1.6050	C
1.5524	6
1.5519	3
1.5497	C
1.5364	6
1.5358	C
1.5202	6
1.5194	3
1.5133	4
1.5118	2
1.5057	1

Frequency (GHz)	Bifurcations $P_{in} = 18$ dBm
1.6200	1
1.6069	2
1.6055	16

Frequency (GHz)	Bifurcations $P_{in} = 18$ dBm
1.6051	C
1.6050	8
1.6049	C
1.6044	6
1.6030	4
1.6029	8
1.6028	C
1.5958	8
1.5932	C
1.5817	8
1.5814	4
1.5806	C
1.5680	3
1.5678	C
1.5521	3
1.5485	C
1.5462	8
1.5458	4
1.5422	8
1.5410	C
1.5361	6
1.5351	C
1.5323	3
1.5320	C
1.5208	6
1.5200	3
1.5147	8
1.5139	4
1.5136	2
1.5056	1

Frequency (GHz)	Bifurcations $P_{in} = 17$ dBm
1.6200	1
1.6062	2
1.6050	16
1.6048	C
1.6045	8
1.6044	C
1.6039	6
1.6038	C
1.5976	8
1.5970	4
1.5955	C
1.5929	3
1.5926	C
1.5912	16
1.5910	C
1.5832	8
1.5828	4
1.5819	C
1.5775	12

Frequency (GHz)	Bifurcations $P_{in} = 17$ dBm
1.5770	6
1.5718	12
1.5711	C
1.5543	6
1.5538	3
1.5510	C
1.5503	16
1.5498	4
1.5494	2
1.5395	4
1.5386	C
1.5350	6
1.5343	C
1.5319	3
1.5317	C
1.5223	6
1.5221	3
1.5187	8
1.5184	4
1.5167	2
1.5060	1

Frequency (GHz)	Bifurcations $P_{in} = 16$ dBm
1.6200	1
1.6056	2
1.6047	4
1.6046	6
1.6041	C
1.6037	6
1.6035	C
1.5906	8
1.5901	C
1.5842	8
1.5840	4
1.5833	C
1.5806	6
1.5797	3
1.5687	6
1.5678	C
1.5655	3
1.5653	C
1.5650	16
1.5649	C
1.5558	3
1.5537	C
1.5530	4
1.5526	2
1.5369	4
1.5360	C
1.5343	3
1.5337	6

Frequency (GHz)	Bifurcations $P_{in} = 16$ dBm
1.5332	C
1.5307	3
1.5306	C
1.5243	6
1.5239	3
1.5211	8
1.5208	4
1.5202	2
1.5073	1

Frequency (GHz)	Bifurcations $P_{in} = 15$ dBm
1.6200	1
1.6049	2
1.6042	4
1.6039	8
1.6037	C
1.5993	4
1.5987	C
1.5907	3
1.5906	C
1.5900	8
1.5897	C
1.5845	8
1.5845	8
1.5842	4
1.5837	C
1.5812	6
1.5803	3
1.5769	C
1.5753	6
1.5726	C
1.5683	6
1.5674	C
1.5651	3
1.5649	C
1.5562	3
1.5542	C
1.5538	4
1.5534	2
1.5359	4
1.5356	8
1.5354	C
1.5348	3
1.5330	12
1.5327	C
1.5307	3
1.5305	C
1.5300	3
1.5299	C
1.5297	8
1.5293	C
1.5274	8

# Appendix

Frequency (GHz)	Bifurcations $P_{in} = 15$ dBm
1.5269	4
1.5262	C
1.5244	12
1.5239	3
1.5212	8
1.5209	4
1.5204	2
1.5072	1

Frequency (GHz)	Bifurcations $P_{in} = 14$ dBm
1.6200	1
1.6047	2
1.6037	3
1.6034	8
1.6031	C
1.6028	6
1.5986	C
1.5974	6
1.5958	4
1.5938	6
1.5922	C
1.5854	4
1.5827	C
1.5826	6
1.5821	2
1.5793	6
1.5769	2
1.5710	4
1.5697	6
1.5693	C
1.5690	6
1.5688	C
1.5666	6
1.5657	C
1.5592	4
1.5585	C
1.5575	12
1.5571	3
1.5555	C
1.5551	4
1.5546	2
1.5341	4
1.5338	8
1.5337	C
1.5322	3
1.5310	C
1.5286	3
1.5280	C
1.5254	6
1.5250	3
1.5229	4
1.5219	2
1.5077	1
1.6200	1

Frequency (GHz)	Bifurcations $P_{in} = 13$ dBm
1.6037	2
1.6030	6
1.6027	C
1.6023	6
1.6022	C
1.5984	8
1.5980	6
1.5962	4
1.5929	6
1.5915	8
1.5905	C
1.5896	6
1.5891	C
1.5845	6
1.5840	3
1.5822	6
1.5817	4
1.5814	2
1.5669	4
1.5666	6
1.5663	C
1.5651	3
1.5647	6
1.5645	12
1.5643	C
1.5624	8
1.5622	C
1.5606	4
1.5603	2
1.5598	C
1.5588	2
1.5373	3
1.5570	2
1.5494	1
1.5336	2
1.5319	4
1.5314	C
1.5302	6
1.5310	C
1.5301	16
1.5299	C
1.5296	3
1.5290	6
1.5277	3
1.5259	C
1.5258	2
1.5124	1

Frequency (GHz)	Bifurcations $P_{in} = 12$ dBm
1.62 --> 1.49	1

## Distribution

Admnstr  
Defns Techl Info Ctr  
Attn DTIC-DDA (2 copies)  
Cameron Sta Bldg 5  
Alexandria VA 22304-6145

US Army CECOM  
Attn AMSEL-RD-NV-ADS-SP M Kovach  
FT Monmouth NJ 07703-5206

US Army Rsrch Lab  
Attn AMSRL-OP-CI-A J McCorkle  
Attn AMSRL-OP-SD-TA Mail & Records  
Mgmt  
Attn AMSRL-OP-SD-TL Tech Library  
(3 copies)  
Attn AMSRL-OP-SD-TP Tech Pub

US Army Rsrch Lab (cont'd)  
Attn AMSRL-SL-CE S Hayes  
Attn AMSRL-SL-CN C Glenn  
Attn AMSRL-WT-N Chf  
Attn AMSRL-WT-NA Chf  
Attn AMSRL-WT-ND Chf  
Attn AMSRL-WT-NF Chf  
Attn AMSRL-WT-NF E Scannell  
Attn AMSRL-WT-NF N Tesny  
(12 copies)  
Attn AMSRL-WT-NF R Kaul  
Attn AMSRL-WT-NF T Bock  
Attn AMSRL-WT-NH A Mark (12 copies)  
Attn AMSRL-WT-NH Chf  
Attn AMSRL-WT-N Sr Rsrch Scntst  
Adelphi MD 20783-1197