

7962IX

UNCLASSIFIED

NAA-SR-13

Subject Category: METALLURGY AND CERAMICS

UNITED STATES ATOMIC ENERGY COMMISSION

TECHNIQUE OF RESISTIVITY MEASUREMENTS
ON CYCLOTRON BOMBARDED GRAPHITE

By
F. R. Gilmore
C. R. Malmstrom
A. A. Jarrett

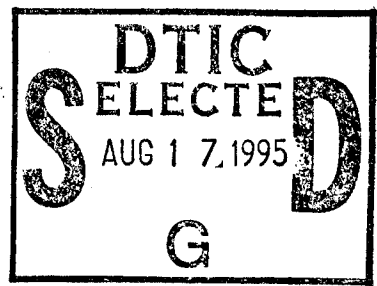

April 4, 1949

North American Aviation, Inc.
Los Angeles, California

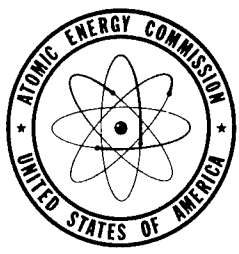

Technical Information Service, Oak Ridge, Tennessee

19950815 059

UNCLASSIFIED

DTIC QUALITY INSPECTED 6

DISTRIBUTION STATEMENT A
Approved for public release;
Distribution Unlimited

Date Declassified: December 5, 1955.

This report was prepared as a scientific account of Government-sponsored work. Neither the United States, nor the Commission, nor any person acting on behalf of the Commission makes any warranty or representation, express or implied, with respect to the accuracy, completeness, or usefulness of the information contained in this report, or that the use of any information, apparatus, method, or process disclosed in this report may not infringe privately owned rights. The Commission assumes no liability with respect to the use of, or from damages resulting from the use of, any information, apparatus, method, or process disclosed in this report.

This report has been reproduced directly from the best available copy.

Issuance of this document does not constitute authority for declassification of classified material of the same or similar content and title by the same authors.

Printed in USA, Price 20 cents. Available from the Office of Technical Services, Department of Commerce, Washington 25, D. C.

TECHNIQUE OF RESISTIVITY MEASUREMENTS ON
CYCLOTRON BOMBARDED GRAPHITE

WRITTEN BY:

F. R. Gilmore
C. R. Malmstrom
A. A. Jarrett

WORK DONE BY:

A. A. Jarrett
F. R. Gilmore
C. R. Malmstrom

April 4, 1949

APPROVED BY

C. Starr
C. Starr, Chief
Special Research

ABSTRACT

Accession For	
NTIS CRA&I	<input checked="" type="checkbox"/>
DTIC TAB	<input type="checkbox"/>
Unannounced	<input type="checkbox"/>
Justification _____	
By _____	
Distribution/ _____	
Availability Codes	
Dist	Avail and/or Special
A-1	

Graphite, exposed to proton, deuteron or alpha particle bombardment in the 60-inch cyclotron at Berkeley, undergoes large changes in electrical resistivity. The change is a function of the exposure and of the distance along the path of the particles in the graphite.

A previous report described a method for measuring these changes in resistivity and included some preliminary experimental results. The present work describes further refinements of both the experimental technique and the analytical procedures. The resistivity change in layers 0.001" thick in graphite can be measured to an accuracy of about 5% using these techniques.

This report is based upon studies conducted for the Atomic Energy Commission under Contract AT-11-1-GEN-8.

1. INTRODUCTION

Cyclotron bombardment of graphite with high energy charged particles has been shown to change the physical properties of the graphite^{(1)*}. In particular, the electrical resistivity of the graphite is found to be greatly increased after exposure to the cyclotron beam. The affected region of the graphite is determined by the cross-sectional area of the beam and the range of the particles in graphite. These dimensions are approximately as follows: width of beam in vertical direction 150 mils (0.150 inch), range of deuterons 55 mils, range of alpha particles and protons 25 mils. Because the affected region is small it is necessary to make resistivity measurements on very small volumes to obtain the change in resistivity as a function of the distance along the particle path. Measurements of this type are desirable because the measurements can be compared with the effects predicted by theory as a function of total bombarding flux and beam particle energy.

A previous publication by this laboratory⁽²⁾ described a technique for measuring the resistivity change as a function of the range of particles in graphite. A preliminary theory⁽³⁾ was developed for this phenomenon. To facilitate development of a more complete theory⁽⁴⁾ the present report describes experimental improvements of the original techniques.

2. EXPERIMENTAL PROCEDURE

The experimental techniques employed were substantially those described in Reference 2. In summary, the bombarded graphite specimen (National Carbon Company grade C-18) was mounted on an insulator block with heavy copper clamps. The details of mounting and specimen dimensions are shown in Figure 1. Tungsten probes made of 15 mil (0.015 inch) wire and rounded at the ends penetrated the lower surface of the graphite across a known separation within the bombarded region. A constant current of 0.500 amperes was maintained through the specimen. This current was controlled by a variable series resistance and measured by measuring the potential difference across a series standard resistance potentiometrically. The current was insufficient to cause any appreciable heating of the specimen. The electrical measurements were made while the mounted specimen was held on the magnetic chuck of a surface grinder as shown in Figure 2. The insulator block was screwed to a cold-rolled steel sheet, as shown in Figure 1, which provided the means for firm positioning on the chuck.

*References are listed at end of report on Page 17.

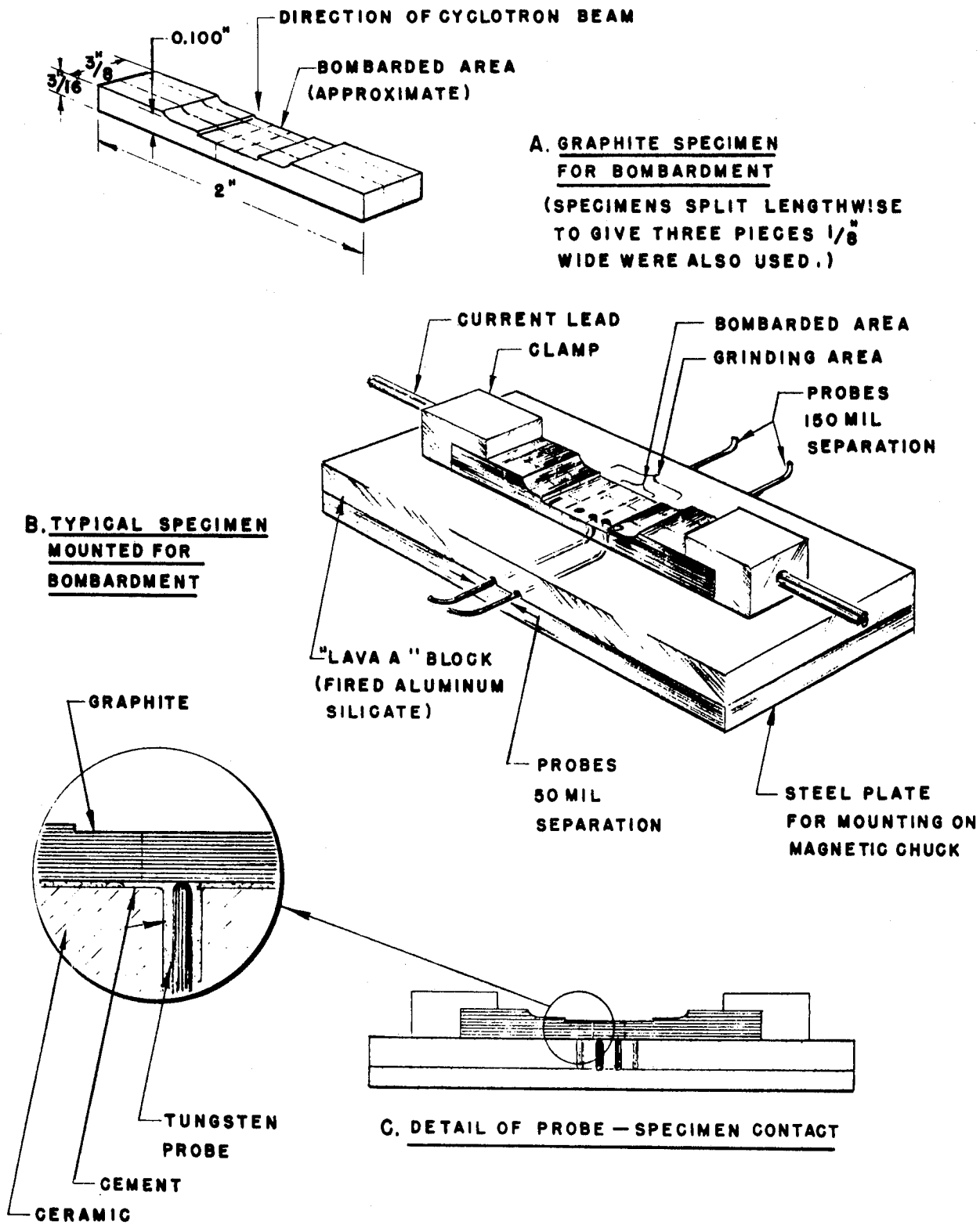
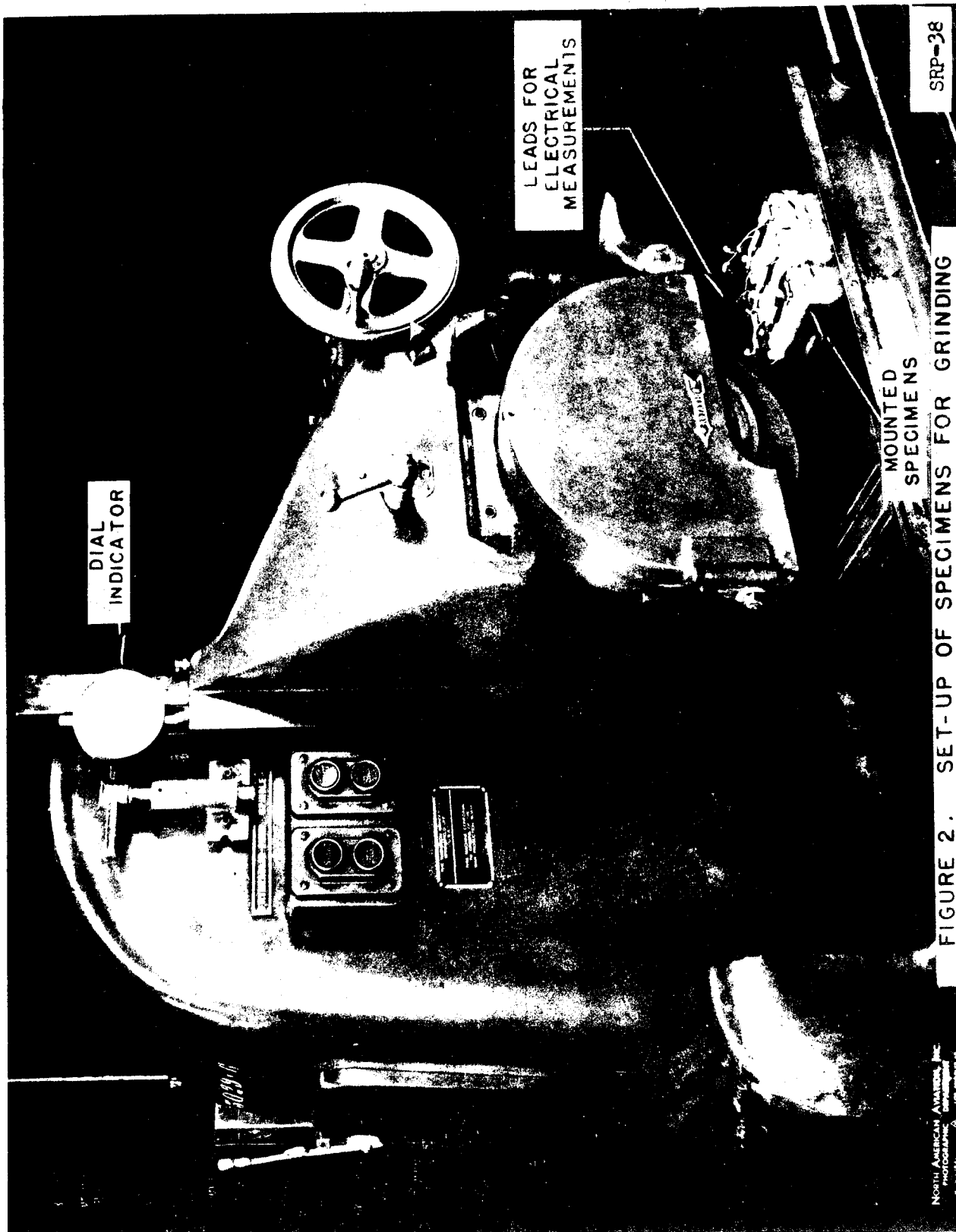

FIGURE I. SPECIMEN MOUNTING



SRP-38

FIGURE 2. SET-UP OF SPECIMENS FOR GRINDING

NORTH AMERICAN AVIATION, INC.
PHOTOGRAPHIC
DIVISION
CITY CENTER BLDG.
ANN ARBOR, MICH.

Layers 1 mil thick by 3/8" wide were removed from the upper surface of the specimen by the grinding wheel in two cuts of 1/2 mil each. Resistance measurements were made after each mil was removed by measuring the potential difference between the probes potentiometrically while the standard current flowed through the specimen. Room temperature measurements were made throughout the grinding to check on any ambient changes.

The depth of each cut was measured by a Federal dial indicator, 0.1 mil per division, mounted between the grinding head and the frame of the grinder. Before each cut, the dial indicator was carefully brought to an even mil mark by using the grinder hand-feed and then tapping the grinding head with a mallet for the last few thousandths of a mil adjustment. It was fairly easy to obtain a desired position as precisely as the dial indicator could be read (about ± 0.01 mil), without overshooting more often than once every few hundred cuts so that back lash in the dial indicator was of no importance. It was found by careful calibration with Johansen blocks that although the dial indicator could be read to 0.01 mil the accuracy of the dial indicator was good to only 0.1 mil. Moreover, it was found that no calibration could be used as it changed from time to time as the dial indicator was used. In order to reduce the error in the depth of cut as measured by the dial indicator, two unbombarded pieces of graphite were ground simultaneously with a bombarded specimen and the actual depth of cut calculated from the change of resistance of the two unbombarded graphite specimens as described in Section 3. The grinding was continued well beyond the range of the particles in order to obtain the resistivity of the graphite of the bombarded specimen in the unaffected region.

The first sample holders were designed to hold the probes approximately 100 mils apart. Later it appeared, as discussed below, that the cyclotron beam was not sufficiently uniform over 100 mils. In order to take measurements over a more uniformly bombarded region, the probe spacing was reduced to 50 mils. Immediately, the random errors in the measured data (see Section 3) approximately doubled. Evidently small variations in the effective point of electric contact between the probes and the graphite, probably caused by vibrations during grinding, was an important source of error: since this was the only error which would increase percentage-wise as the probe spacing decreased. (The potential measurements had approximately the same percentage accuracy in the two cases). In order to investigate this source of error more thoroughly an additional piece of graphite was fastened to the top of the specimen with an insulating cement, and one mil layers were then ground from this piece. With this arrangement, any electrical variation which occurred would be caused by probe movement during the grinding process. Such variations were observed.

As a result of this experiment, the probes were cemented to the samples prior to all grindings. A thiokol-base cement was used with a

lead peroxide accelerator, and setting was accomplished by heating between 50° and 65° C for twelve hours. As a further safeguard, sample holders were constructed which incorporated probes of both 50 mil and 150 mil spacing, and measurements of potentials between both sets of probes were made for each specimen. Thus, if probe movement were still significant, the 150 mil probe data might be roughly corrected for non-uniformity of bombardment of the region between the probes and used in lieu of the 50 mil data. This was found to be an unnecessary precaution, but since the bombardment was not uniform the 150 mil probe data gave results for a different total exposure than the 50 mil data. In effect this allows an approximate determination of resistivity as a function of range for two different amounts of bombardment in a single grind.

More recent work has shown that large errors in resistivity determinations exist due to the bending of the equipotential lines in the bombarded region. This effect is discussed in Section 4. It is concluded from this study that the experimental procedure to be followed in the future is to oscillate the specimen during bombardment to give a uniformly bombarded region 250 mils long. Two probes with 100 mils separation, symmetrically placed and cemented within the bombarded area will then be used to measure resistivity changes in the graphite as a function of range.

Deuterons, proton and alpha particles from the Berkeley 60" cyclotron were used in bombarding the graphite specimens. The technique for obtaining the integrated beam current to which the graphite is exposed is described in Reference 5. This is done by mounting a thin foil in front of the specimen. The induced radioactivity is determined as a function of position relative to the graphite specimen and the probes can then be placed to span the uniform part of the beam. Knowing the total integrated beam current, the total count on the foil, and the integrated count on that part of the foil between the probes, one finds the microamperes hours/cm² between the probes.

3. ANALYTICAL TECHNIQUE

A. General Theory

The electrical conductance of the slab (wlx) in Figure 3 can be regarded as the sum of the conductances $\frac{w dx}{\rho l}$, of the infinitesimal slabs $w dx$, where ρ is the resistivity of the infinitesimal slab.

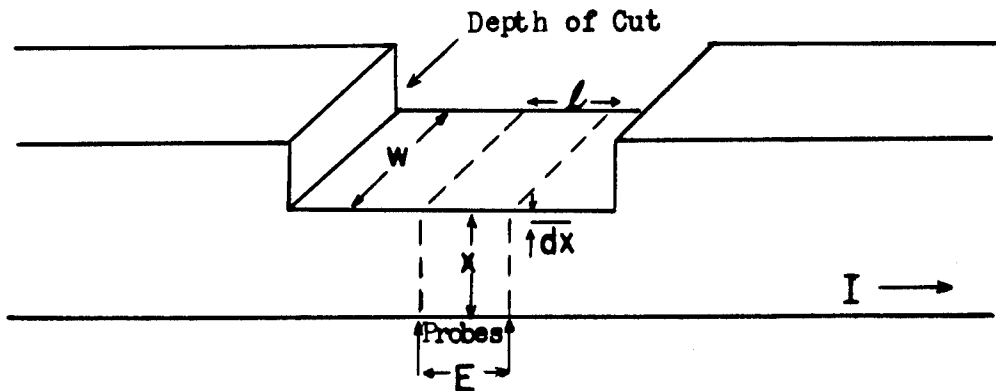

Figure 3

The total conductance can also be expressed as $\frac{I}{E}$, where I is the total current and E is the potential drop across l so that the conductance of the layer dx for constant I is

$$\frac{w dx}{\rho l} = I d\left(\frac{1}{E}\right)$$

whence

$$\rho = \frac{w}{I l \frac{d\left(\frac{1}{E}\right)}{dx}} \quad \dots(1)$$

The increase in resistivity due to bombardment can be conveniently expressed by the dimensionless ratio

$$\frac{\rho - \rho_0}{\rho_0} = \frac{\left[\frac{d\left(\frac{1}{E}\right)}{dx} \right]_0}{\frac{d\left(\frac{1}{E}\right)}{dx}} - 1 \quad \dots(2)$$

where the subscript zero designates the region beyond the furthest point of particle penetration, where the graphite is unaffected by the bombardment.

B. Calculation Methods

The method used to calculate $\frac{d(\frac{1}{E})}{dx}$ before the dial indicator errors were found, was to plot the experimental values of $\frac{1}{E}$ against x and draw a smooth curve through the points. Values of $\frac{1}{E}$ were then read from the curve at 1 mil intervals, and the first differences calculated. The first differences were then plotted and smoothed first differences taken from the curve. Second and third differences were then calculated from the smoothed first differences and the derivative was finally calculated by the formula (Ref. 6, p. 64)

$$\frac{d(\frac{1}{E})_3}{dx} = \frac{\Delta_2 + \Delta_3}{2} - \frac{\Delta_1^3 + \Delta_2^3}{12} \quad \dots(3)$$

The subscript refers to the number of the observation and the superscript refers to the difference. The results of graphical smoothing of the same data by two different analysts differed by as much as 10% at the resistivity peak. When the probe spacing was decreased from 100 to 50 mils, as mentioned in the previous section, the experimental data immediately became more scattered. Graphical smoothing became so obviously subjective that several numerical methods of smoothing were tried. Calculations were carried out both for a smoothing coefficient of 1/17 and a smoothing coefficient of 1/270 (Reference 6 pp. 303-316). The resulting curves were reasonably "smooth" but the smoothing appeared to flatten and depress the formerly sharp peak in the resistivity curve. It was obviously necessary to increase the accuracy of the measurements in order to reduce the scatter so that the resistivity could be calculated analytically.

After the random errors due to probe movement were decreased by cementing the probes, a large random error still remained. This could be due to either the dial indicator error or the inhomogeneity of the graphite, or both, since electrical errors were small compared to observed errors. Two blank (unbombed) specimens were ground simultaneously to separate if possible the causes of the errors. High correlation coefficients (70 to 95%) in the deviations of $\Delta(\frac{1}{E})$ from its mean value for the two blanks showed that the large random errors were primarily dial indicator errors and that the errors due to inhomogeneity of the graphite were negligible.

Since a permanent indicator calibration was apparently not possible, it was decided to grind two blanks simultaneously with each specimen and use the blank data to correct the dial indicator readings.

Since the dial indicator is never off by more than 0.2 mils (which is a negligible error in terms of the position of any particular cut) the correction computations may be simplified merely by correcting for the error in depth of each individual cut. If, for a particular "one-mil" cut $\Delta (\frac{1}{E})$ for the two blanks is 10% larger than the mean Δ then the cut was evidently 1.10 mils and $\Delta (\frac{1}{E})$ for the bombarded specimens can be corrected to a standard, one-mil cut by multiplying by the ratio $\frac{1.00}{1.10}$. The quality of the correction is shown by the correlations between the two blanks. In every instance the average of two blanks is taken unless there is a gross discrepancy between the two corrections. In this case, the correction which gives the best fit with the general trend of the curve is selected and the other value is rejected.

Before cementing the probes and before making the dial indicator corrections as shown above, the r.m.s. Δ^3 (the third differences) is generally between 20 to 35% for the 50 mil probes. After cementing the probes and making the proper dial indicator correction the r.m.s. Δ^3 is reduced to 4-9%. If the Δ^3 term in Eq. (3) is expanded in terms of the first differences Δ , any error in a Δ is found to add up instead of cancel in the two terms on the right. Hence, zero is a better approximation of the Δ^3 term in Eq. (3) than are the erroneously large values given by the unsmoothed data. Eq. (3) then simplifies to

$$\frac{d(\frac{1}{E})_3}{dx} = \frac{\Delta_2 - \Delta_3}{2} \dots(4)$$

When Eqs. (4) and (2) are used with the latest corrected but unsmoothed data, the results are accurate enough to give a well-defined curve, as shown in Figure 4, without the objective or subjective distortions introduced by numerical or graphical methods of smoothing.

4. SOURCES OF ERROR

A. Random Errors

The following sources of error, some of which were discussed in Section 3, contribute to the random errors:

a) Wandering probe contact.

This error has been reduced to less than 1% by cementing the probes as described in Section 3.

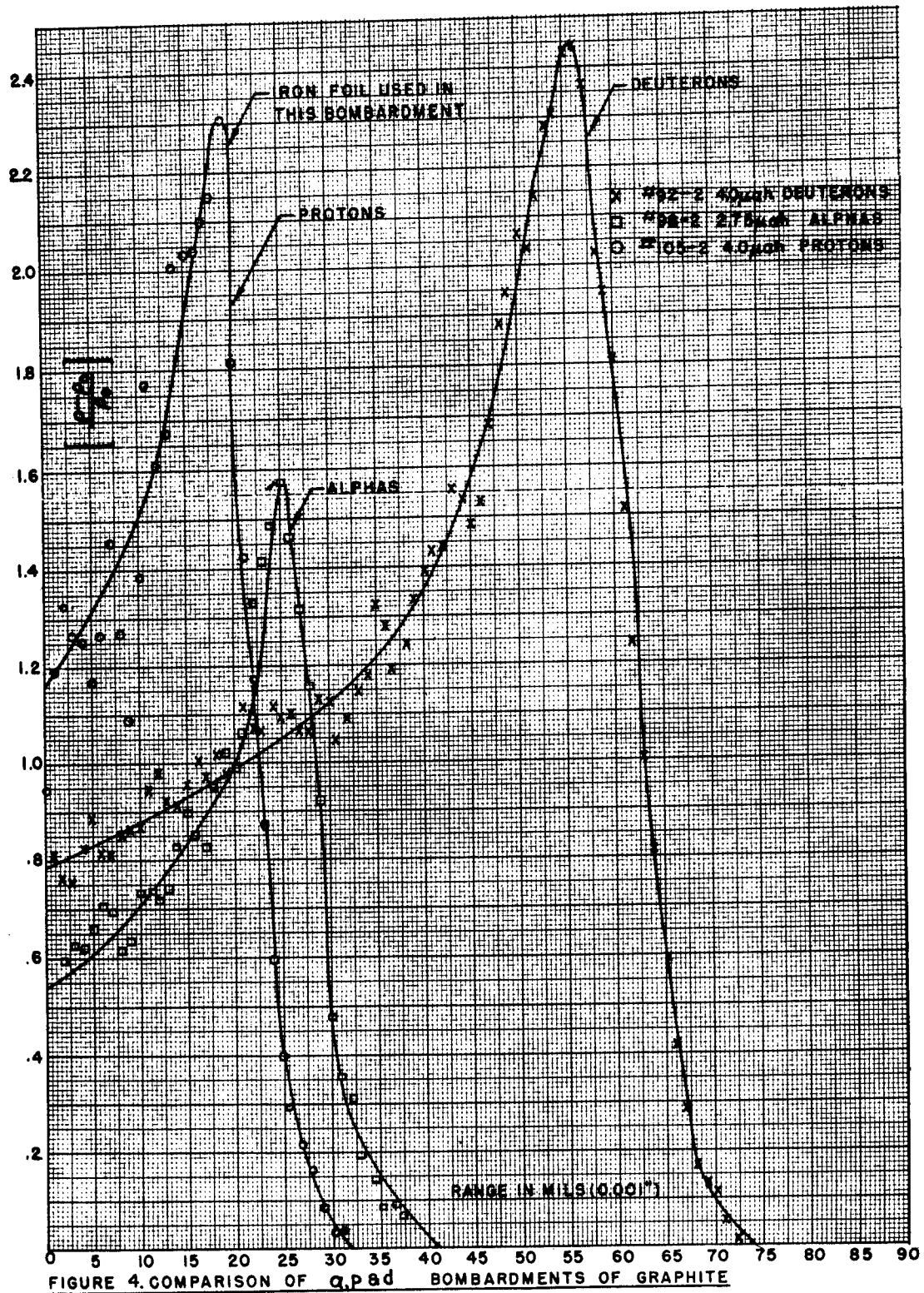

b) Graphite inhomogeneity.

Short range inhomogeneity (in the order of one mil) has been shown to be negligible by the high correlation coefficient in $\Delta \left(\frac{1}{E}\right)$ between two blanks ground simultaneously. Long range inhomogeneity of graphite would appear as a systematic error, but the uniformity of resistivity as a function of depth of cut for the blank specimens would indicate that this error is small.

c) Dial Indicator Error.

The dial indicator is shown to be unsuitable for measuring distances of the order of 1 mil. However, depth of cut calculated from the change in resistance of two blanks is good to $\pm 5\%$.

d) Resistance measurement.

The resistance measurement is dependent upon the precision of making two potentiometric measurements and in maintaining constant temperature throughout the circuit. The potential difference between the probes is measured to ± 0.2 microvolts. The difference in potential difference for one mil cuts at the start of the grinding is approximately 10 microvolts so the error due to electrical measurements may be as high as 4%. This error decreases as grinding proceeds because the change in E for a one mil cut increases as the thickness of the specimen decreases.

The current thru the specimen is kept constant to one part in fifty thousand so the error due to that source is negligible. The error due to temperature changes is also negligible because of the low temperature coefficient of resistivity of the graphite.

These four sources of error contribute to random errors. By analysis of the experimental data one finds the overall probable error from these sources is of the order of $\pm 5\%$ in measuring the fractional resistance increase within a single one mil cut of graphite between 50 mil probes.

B. Systematic Errors

There exist still other sources of error which are not random but which affect the validity of the results.

- a) It is known that the increase in resistivity due to bombardment is annealed out at high temperatures. It now appears

that a large percentage will be annealed out if the specimen is held at 50° C for long periods of time. The cement used for fixing the probes is a thermal setting cement and the specimens were heated as high as 65° C for twelve hours to set this cement. In the future this error will be eliminated by using a cement which will set at room temperature, and by standardizing the temperature history for all specimens from time of bombardment until grinding.

- b) A cyclic error in the dial indicator would produce a systematic error in the results. Checking one dial indicator against another dial indicator indicates that this error is probably negligible.
- c) A resistivity measurement on a layer of graphite is accurate only if the current lines are parallel to the boundary of the layer removed; then no current flows across the boundary and the electrical circuit is that of two resistors in parallel.

The geometry of the irradiated section is such that the resistivity changes rapidly both in depth and along the length of the specimen, in the area opposite to and between the various probes. Hence, one would expect a deviation in the direction of the current lines from the ideal, and a systematic error in the measurement of resistivity.

The magnitude of the error is difficult to estimate. The problem reduces accurately to a two-dimensional one because of the uniformity of the irradiating beam along the width of the specimen. To avoid the great amount of calculation required in an analytical estimate of the error, an experimental determination of its magnitude was made on a two dimensional analog. The analog consisted of a network of resistors so chosen as to approximate the resistance contours of the specimen.

The results of the measurements are given in detail in NAA-SR-29. A nomogram, shown in Figure 5, has been constructed from these data and gives the correction factors for the deuteron bombarded specimens measured with 50 mil probes. The correction factors, somewhat fortuitously, apply to all parts of the deuteron range. The nomogram results are given for two typical contours of resistance as a function of distance along the length of specimen. Other similar contours

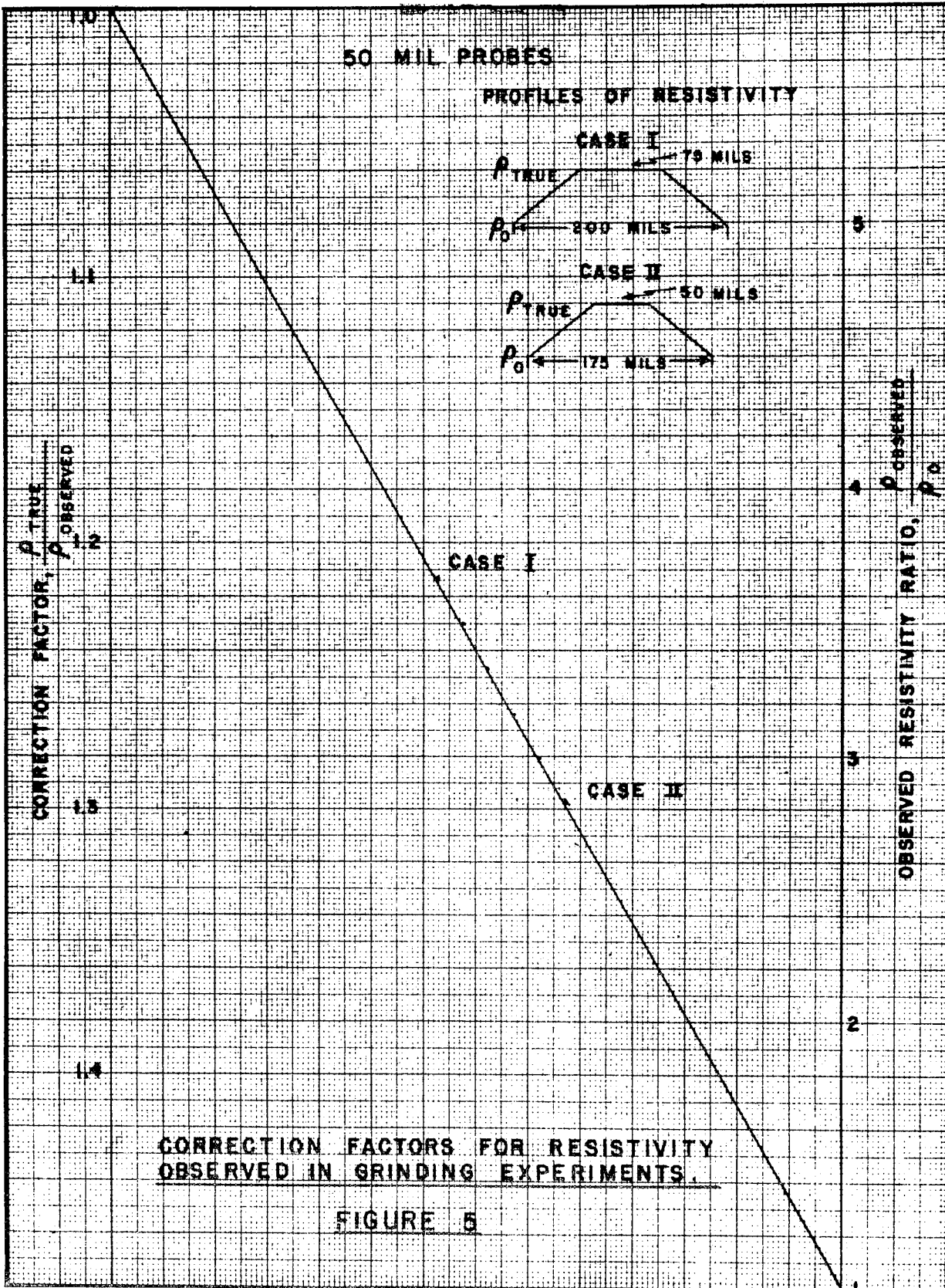

might be interpolated on the same nomogram. It is believed that the errors in the adjusted values of resistivity, obtained using these correction factors, do not exceed 5 per cent.

Other results from measurements on the resistance analog indicate that no correction will be necessary for the bombarded specimens to be used in the future. As mentioned earlier these specimens will have a uniformly bombarded area 250 mils in length, and will be measured using a 100 mil probe separation. Any correction factor here would be a fraction of 1 per cent.

5. RESULTS

An example of the results obtained for each of the three particles is shown in Figure 4. It will be noted that the range of protons and alpha particles differ by about 6 mils. This is due to the use of a 2 mil iron foil for integrating the proton current whereas the alpha particle beam was integrated using a thin bismuth deposit on an aluminum foil.

The ordinate as shown in Figure 4 is the fractional increase in resistivity due to bombardment and not the absolute resistivity. In order to obtain the resistivity of the bombarded graphite between 50 mil probes it would be necessary to know the distance between the effective contact points of the probes. The distance between probes was measured after each grinding experiment with a traveling microscope, but the contact area of each probe is about 5 mils in diameter so it is possible to be in error by 10 parts in 50 or 20 per cent in measuring the absolute resistivity.

The fractional increase in resistivity due to bombardment has been measured for a total of thirty specimens bombarded with protons, deuterons, or alpha particles. By making the corrections discussed above and by drawing a smooth curve through the final points, the fractional increase in resistivity of a one mil layer of graphite between 50 mil probes can be measured to ± 5 per cent.

It is planned to continue this work to obtain resistivity changes due to larger exposures and to obtain more reliable results by:

- a) Control of any annealing prior to the grinding.
- b) Increasing uniformity of bombardment by oscillating the sample during bombardment. This will also allow use of larger probe separations.

REFERENCES

1. Parkins, W. E., NAA-SR-3 (Formerly AL-328), 1947
2. Malmstrom, C. R., NAA-SR-10 (Formerly AL-333), 1948
3. Brown, F. W., NAA-SR-4 (Formerly AL-329), 1948
4. Brown, F. W., NAA-SR-14 (To be published)
5. Yockey, H. P., NAA-SR-21, 1948
6. Whittaker and Robinson, "The Calculus of Observation",
Fourth Edition, Blackie and Son Limited, London, 1924.
7. Donoghue, J. J., NAA-SR-29 (To be published)