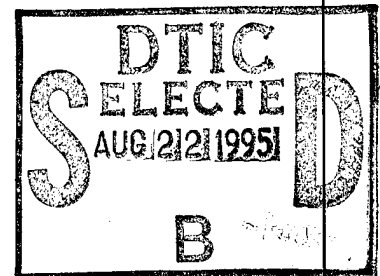

**COMBAT RATION
ADVANCED MANUFACTURING
TECHNOLOGY DEMONSTRATION
(CRAMTD)**

"Optimizing Retort Sterilization Process"
Short Term Project (STP) #6

FINAL TECHNICAL REPORT
Results and Accomplishments (October 1991 through December 1993)
Report No. CRAMTD STP #6 - FTR 7.0
CDRL Sequence A004
June 1995

CRAMTD CONTRACT NO. DLA900-88-D-0383
CLIN 0003

Sponsored by:
DEFENSE LOGISTICS AGENCY
Cameron Station
Alexandria, VA 22304-6145



Contractor:
Rutgers, The State University of New Jersey
THE CENTER FOR ADVANCED FOOD TECHNOLOGY*
Cook College
N.J. Agricultural Experiment Station
New Brunswick, New Jersey 08903

Principal Investigator: Henderikus B. Bruins

Dr. John F. Coburn
Program Director

TEL: 908-445-6132
FAX: 908-445-6145

DTIC QUALITY INSPECTED 2

19950821 040

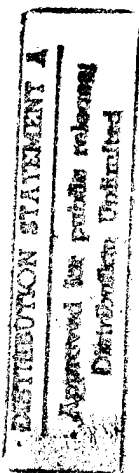

REPORT DOCUMENTATION PAGE

Form Approved
OMB No. 0704-0188

Public reporting burden for this collection of information is estimated to average 1 hour per response, including the time for reviewing instructions, searching existing data sources, gathering and maintaining the data needed, and completing and reviewing the collection of information. Send comments regarding this burden estimate or any other aspect of this collection of information, including suggestions for reducing this burden, to Washington Headquarters Services, Directorate for Information Operations and Reports, 1215 Jefferson Davis Highway, Suite 1204, Arlington, VA 22202-4302, and to the Office of Management and Budget, Paperwork Reduction Project (0704-0188), Washington, DC 20503.

1. AGENCY USE ONLY (Leave blank)		2. REPORT DATE June 1995	3. REPORT TYPE AND DATES COVERED Final Oct. 1991 - Dec. 1993	
4. TITLE AND SUBTITLE Optimizing Retort Sterilization Process (Short Term Project (STP) #6)			5. FUNDING NUMBERS C-DLA900-88D-0383 PE-7811s PR-88003	
6. AUTHOR(S) Henderikus B. Bruins				
7. PERFORMING ORGANIZATION NAME(S) AND ADDRESS(ES) Rutgers, The State University of New Jersey The Center for Advanced Food Technology Cook College, NJ Agricultural Experiment Station New Brunswick, NJ 08903			8. PERFORMING ORGANIZATION REPORT NUMBER FTR 7.0	
9. SPONSORING/MONITORING AGENCY NAME(S) AND ADDRESS(ES) Defense Logistics Agency Cameron Station Alexandria, VA 22304-6100			10. SPONSORING/MONITORING AGENCY REPORT NUMBER	
11. SUPPLEMENTARY NOTES				
12a. DISTRIBUTION/AVAILABILITY STATEMENT DIST "A"			12b. DISTRIBUTION CODE	
			<div style="border: 1px solid black; padding: 5px; width: fit-content; margin: auto;"> DISTRIBUTION STATEMENT A Approved for public release Distribution Unlimited </div>	
13. ABSTRACT (Maximum 200 words) The Center for Advanced Food Technology was uniquely positioned, with CRAMTD, to evaluate side by side three heating modes on a Stock 1100, single basket retort, using the same racks, crates and control system. The effects of heating mode has been of interest to many in the industry yet direct comparisons were not available. An optimization methodology was developed that evaluates performance in "response" variables important to the industry, e.g., process capacity, product quality, product uniformity and energy costs. The methodology also includes selecting the optimal retort configuration and conditions. The results showed that selection of the appropriate retort system can have significant impact on process capacity, product quality and product uniformity. These all lead to soldier acceptance of the products. The following improvements were achieved with a model food product in comparison to a baseline process: processing capacity could be increased by 49% for Meals Ready to Eat (MRE) and 63% for Half Steam Tray (HST), non-uniformity in product quality could be decreased 75% for MRE and 92% for HST, and mean quality factor could be increased 10% for HST and 3.4% for MRE.				
14. SUBJECT TERMS Retort, Sterilization, Thermostabilization, MRE (Meal, Ready-to-Eat), Tray-Pack Ration			15. NUMBER OF PAGES 38	
			16. PRICE CODE	
17. SECURITY CLASSIFICATION OF REPORT Unclassified	18. SECURITY CLASSIFICATION OF THIS PAGE Unclassified	19. SECURITY CLASSIFICATION OF ABSTRACT Unclassified	20. LIMITATION OF ABSTRACT UL	

Contents

1.0 CRAMTD Final Report STP #6	1
Results and Accomplishments	1
1.1 Introduction and Background	1
1.2 Accomplishments Summary	1
1.3 Conclusions/Recommendations	2
2.0 Program Management	3
3.0 Short Term Project Activities	3
3.1 STP Phase I Tasks	3
a. Identify/Document Literature	3
b. Identify/Document Parameters	4
c. Establish Quality Index	4
d. Identify Instrumentation/Systems	4
3.2 STP Phase II Tasks	5
a. Specify Hardware/Software	5
b. Acquire Hardware/Software	5
c. Install Hardware/Software	5
3.3 STP Phase III Tasks	5
a. Develop Methodology/Criteria	5
b. Establish Baseline Conditions	6
c. Optimize Baseline Processes	6
d. Evaluate Energy Consumption	7
e. Evaluate Combined Modes	7
f. Evaluate Quality Attributes	7
g. Demonstrate Methodology/Technology Transfer	7
4.0 Appendix	8
4.1 Technical Working Papers	
4.2 Distribution List of TWP	
4.3 Time and Event and Mile stones	
4.4 Hardware and Software Supplier Addresses	
4.5 Hardware and Software Specifications	

1.0 CRAMTD Final Report STP #6

Results and Accomplishments

1.1 Introduction and Background

Optimization of the retort process addresses the interactions between retort process parameters and factors such as: product sterility, product quality and package integrity. Variability in any of the process parameters can cause product non-uniformity and/or package defects. Non-uniformity in processing parameters mandates typically longer sterilization cycles to assure commercial sterility at the cost of product quality and higher manufacturing costs. The emphasis of this project was to establish the relationships between process variables and response variables such as: product quality, process capacity and energy utilization. Having established this relationship, a methodological approach was then used to determine the optimal setting of a process.

STP#6 began October 1, 1991 based on a proposal that was submitted to the Defense Logistics Agency on July 11, 1991. Final approval for the project was received on September 19, 1991. The broad objective of the project was to identify the retort factors and variables that influence the sterilization process, and then to develop and document the methodology used to arrive at an optimum retort sterilization process.

Technology transfer was (and is) an integral part of this STP (even beyond the end of this particular contract). After completion of the STP, advice and guidance will be available to the food processors either via the CAFT organization or via selected organizations that are recognized as process authorities in sterilization.

1.2 Accomplishments Summary

The Center for Advanced Food Technology was in a unique position, under the CRAMTD program, to evaluate side by side three heating mode systems on a Stock 1100, single basket retort, using the same racks, crates and control system. The effects of various retort heating modes has been of interest to many in the industry. Data on direct comparisons of various retort heating modes were never available and comparisons had to be made by using data from different types and sizes of retort systems. Via this STP, we were able to generate a data base that compares the various heating modes in a single retort system using the same racks, crates, control system, etc. To develop the data base that compares various retort systems, an optimization methodology was developed that evaluates the performance of a retort system in "response" variables that are important to the industry, such as process capacity, product quality, product uniformity and energy costs. This methodology was used to quantify the effects that heating mode, rotational speed and rack design have on a retort process. The methodology also included a procedure to select the optimal retort configuration and condition. This optimization technique uses weight factors for the various criteria and is not much different from the methodology developed under NCIC (Nontraditional Capital Investment Criteria) NCIC is a methodology which allows us to compare variables of different dimensions and determine an optimal solution. Energy auditing was also part of the retort evaluation. Steam, water and electrical

consumption were monitored during the process and a complete mass and energy balance study was performed to identify and quantify the energy and mass losses. The energy audit and analysis procedures are described further in this report and in the Technical Working Paper (TWP) #77 shown. This study led to several recommendations that can lead to energy savings (TWP) 67 & 93. The results of the work performed during this STP resulted in three presentations at nationally recognized conferences: one at the annual winter meeting of the Association of Agricultural Engineers, and two at the annual conference for The Institute of Thermal Processing Specialists. The Industry has shown a lot of interest in the results obtained during STP#6, an interest which can be quantified by 125 requests for technical working papers as of January 1995 (see appendix 4.4 for more details).

1.3 Conclusions/Recommendations

The main contributions of this STP are methodologies which may be used to evaluate and optimize a retort system.

The results of this STP showed that the selection of the appropriate retort system can have significant impact on process capacity, product quality and product uniformity. These all lead to soldier acceptance of the products. The following improvements were achieved with a model food product in comparison to a baseline process. The processing capacity could be increased by 49% for Meals Ready to Eat (MRE) and 63% for Half Steam Table Tray (HST). The non-uniformity in product quality could be decreased with 75% for the MRE model product and 92% for the HST. The mean quality factor could be increased by 10% for the HST product and 3.4% for the MRE model product. A multi criteria optimization technique was used to determine which retort system was best suited for the model food product system. Overall, STP#6 determined the water cascade and steam/air retort to be better performing retort systems. This recommendation is based on the shorter cycle times required for this system and the relatively quick, uniform come-up times and lower energy consumption. However, additional criteria such as retort maintenance and effect on container damage were not evaluated as functions of the retort heating mode. Other variables such as capital investment, vendor service history, parts availability, machine warranty are very important considerations, but were also not considered in this evaluation.

Since the results of this effort need to be scaled up to the kinds of retorts used throughout industry, we could make a further contribution if we did the same kind of work using a full sized retort. We recommend evaluating the performance of commercial sized retorts, such as the Stock 1300 retort which is located in the CRAMTD facility. By conducting temperature distribution and heat penetration studies, we will be able to address some of the scale up issues that exist in the industry. Also, we would recommend further studying of the effects of heating mode on a commercial scale retort by either converting the existing 1300 retort to a water cascading retort or by possibly leasing a 1300 retort long enough to quantify the performance of this type retort.

2.0 Program Management

STP#6 was a three-phase work activity. The three phases had the following general objectives:

- Phase 1 Conduct a literature search, industry surveys etc. to identify and document the factors and variables which are critical to the sterilization process
- Phase 2 Acquire and install retort hardware and software which are required to evaluate and optimize the retort performance and/or enhance the process uniformity
- Phase 3 Execute retort experiments to establish interaction between retort process variables and product quality and then identify optimal solutions for those variables.

Detailed objectives and statement of work are described in the Technical Proposal for STP#6, dated July 9, 1991. The work activity and status is illustrated on the attached figure 1, CRAMTD STP#6 "Optimizing Retort Sterilization Process", Time and Event and Milestones (Appendix 4.3)

3.0 Short Term Project Activities

3.1 STP Phase I Tasks

a. Identify/Document Literature

An extensive literature search was conducted and a total of more than 170 scientific articles/reports were reviewed. The identified literature related to critical process parameters, product quality, mathematical modeling of heat penetration and effect of packaging geometry on the required retort process. Abstracts information of all the articles were added to an electronic literature data base, using Hyper Writer software from NTERGAID. This data base is now available on the PFMIS bulletin board and was sent to several of our coalition member companies as a stand alone version.

The literature review resulted in the following technical working papers:

- TWP # 39: Optimization Retort Sterilization Process Literature Review "Critical Processing Parameters: Heating Media, Rotation Speed, Rack Design"
- TWP #42: Optimization Retort Sterilization Process: "Process Control Sterilization Technology Symposium 1991 ASAE International Winter Meeting".
- TWP #45: Optimization Retort Sterilization Process. Literature Review: Food Quality Attributes Used as an Indicator of Impact of Thermal Process on Quality on of Canned Food

TWP #55: Development of Numerical Food Quality Index for Evaluation of Retort Processes.

TWP #71: Optimization Retort Process: "Electronic Literature Data Base".

b. Identify/Document Parameters

An Industry survey was conducted at the beginning of this project to establish the parameters that are critical to retort processes and were of most interest to CRAMTD coalition members. Based on this survey, this project focussed its research activities on the effects that heating media, rack design and rotational speed can have on product quality, product quality variation and retort capacity. The results of this survey were published in TWP# 38: " Optimizing Retort Sterilization Process, Industry Survey".

c. Establish Quality Index

It was found that thiamine (B1) and ascorbic acid (C) retention are most frequently used factors to quantify the effect of retort sterilization on food product quality. Mathematical methods exist to predict the "average" food quality for conductive type food products. However, no mathematical model existed to predict average food quality in a combined convection/conduction type food product, such as beef stew.

Therefore, a simple finite element method was developed to predict the quality degradation in a half steam table trays. The product in this case can be a pure liquid, a solid or a combination of the two. The method does require, however, heat penetration studies in various layers of the container. This method was documented in TWP#55, and is applicable to wide variety of containers.

To quantify the quality degradation effects, as function of the various retort parameters, the kinetic degradation factors of thiamine ($D_{250}=156.8$ min, $z= 45$ F) were selected.

d. Identify Instrumentation/Systems

Various hardware and software items that were needed to determine and evaluate retort conditions were identified during this project. The following capital items were either purchased or donated under this contract:

- Digital Reference Thermometer (donated)
- NumeriCal (partial donation)
- Counter Pressure Profiler (sub contract)
- Steam Flow Meter (purchased)
- Water Flow Meter (purchased)
- Electricity Meter (purchased)

Air Flow Meter (purchased)
Adjustable Retort Racks for Pouches (purchased)
Adjustable Retort Racks for Half Steam Table Trays (purchased)

3.2 STP Phase II Tasks

a. Specify Hardware/Software

- Specifications for the following hardware items are attached in appendix 4.4
- Counter Pressure Profiler
- Steam Flow Meter
- Water Flow Meter
- Air Flow Meter
- Adjustable Retort Racks for Pouches

b. Acquire Hardware/Software

The suppliers that were used for each of the hardware and software items are identified in appendix 4.4.

c. Install Hardware/Software

Installation of hardware and software was completed during the length of the project, with the exception of the air flow meter. The installation and testing of this meter could not be completed before the end of the project. Extending the project for this additional data was not cost beneficial.

3.3 STP Phase III Tasks

a. Develop Methodology/Criteria

Methodology and criteria to evaluate retort process performances was developed and sent to selected coalition members for review and comments. Comments were incorporated where appropriate and the methodology was then issued as a technical working paper # 67: "Development of Methodology for Conducting and Analyzing Temperature Distribution Studies for Evaluation of Retort Processes".

To evaluate the various retort parameters, a model food product needed to be identified. After the evaluation of various systems, a model system was selected that consisted of rubber chunks in a water media. This particular model food system simulated a combined convection and conduction type heat transfer model, similar to products such as beef chunks in gravy and beef stew. The advantage of the model system was that it could be used several times without changes in heat transfer properties. This reduced the cost and time to prepare samples and reduced the variability due to changes of the food characteristics inside the container. After selection of the model food system, heat penetration studies were performed to quantify the heating characteristics of this model food system as a function of the heating media and rotational speed.

b. Establish Baseline Conditions

For ease of comparison of the various retort setups, a baseline process was quantified for each container type, against which relative improvements were measured. A full water immersion still cook with plastic spacer mats (11 racks/crate, six cans per layer) between the can layers was selected as the base line process of half steam table tray. A full water immersion still cook with injection molded plastic pocket racks (15 pouches/rack, 25 racks/crate) was selected as the baseline process of MRE pouches. Both process configurations are extensively used in the combat ration industry. The control system, that was used for all process configurations, was a Kunke PLC with PID loop control loops for both temperature and pressure. No ramp functions were programmed during the heating phases, only a pressure ramp was programmed during the cooling phase. More details on the base line process are documented in TWP#74 & TWP#76.

c. Optimize Baseline Processes

Temperature distribution tests were conducted to quantify the come up time distribution and the retort performance during the hold phase. This data was then used to calculate specific processes that would lead to commercial sterile products. A total of three heating modes, two rotational speeds, two container geometries and several rack designs with variable space between containers were evaluated. As criteria for optimization, we used the quality, variation in quality, retort capacity and energy costs. By using a multi variable optimization technique (TWP #93), we were able to quantify the advantages and disadvantages of the various retort configurations. Results of these experiments are published in TWP#74 & TWP#76.

In general, a rotating retort system performed significantly better than still retort systems. When comparing the various heating media's, the steam/air and water spray heating media systems out performed the full water immersion system, due to higher capacity and lower energy costs. However, additional criteria might have to be considered before deciding to switch over to these heating medias. For example, rotating steam/air and water spray cook systems might increase the damage to the containers due to the lack of buoyancy associated with full water immersion cook systems. The additional gravitational forces on the container might cause movement of these containers if they are not properly locked in the cage and result in abrasion marks on containers. Also, the steam/air and water spray cook systems use air as a pressure media, and the oxygen content of this air can cause corrosive effects unless proper precautions are taken such as use of a stainless steel retort shell.

Recommended rack design for half steam table trays is the plastic spacer mat, and for MRE pouches the PP15 rack. Both rack designs are extensively used in the combat ration industry. A more in-depth study of the effect of rack clearance is documented in TWP#91, a master thesis study by Lorna Contreras. She concluded that there were significant interactions between rack clearance, rotating speed and heating media.

It should be noted that the rating of various retort configurations is a function of the product heating characteristics and the selection of the weight factors. A change in the type of product which was evaluated and/or in the weight factors might lead to a different rating of each retort setup and potentially to a different optimal retort setting.

d. Evaluate Energy Consumption

As part of the evaluation of the various retort modes, we conducted a complete energy audit for steam, water and electric consumption. The results of these audits are published in technical working paper TWP#77 "Energy Auditing of Retort Processes". It concluded that steam/air retorting is the least energy demanding retort mode. It also determined that, for the selected model food system, rotation results in lower energy requirements due to shorter cycle times. Based on the energy audit data, several energy conservation methods were generated. These suggestions are published in TWP#77.

e. Evaluate Combined Modes

Combined heating modes have the potential to save significant energy. An example was identified in TWP#77 which combines full water immersion cooking with water spray cooling. The advantages of such a combined mode are: i) good temperature distribution during the heating phase, ii) 100% recovery of all the super heated water, iii) ~7% increase in throughput rate due to fast cooling and drain cycle, iv) 22% savings in steam consumption.

f. Evaluate Quality Attributes

Thiamine in the liquid phase was selected as the key quality indicator. All retort conditions were evaluated by using the heat penetration data for the liquid phase. Not only did we evaluate the average quality, but we also predicted the variation in quality from container to container and over multiple retort batches. Both quality factors are important to the consumer as the consumer expects to see the same quality in the product that it consumes. It was demonstrated that by proper selection of retort conditions that the absolute quality can be increased 10% and that the non-uniformity in quality can be decreased by 65% (HST).

g. Demonstrate Methodology/Technology Transfer

At the Thirteenth Annual Conference and Workshop of the Institute for Thermal Processing Specialists (1993), a presentation was given to explain the methodology that CRAMTD developed under STP#6 for selection/determination of an optimal retort process. Actual data from the half steam table tray experiments were used for the demonstration. As a result of this presentation, copies of technical working papers have been requested by the attendees of this meeting.

At the Fourteenth Annual Conference and Workshop of the Institute for Thermal Processing Specialists (1994), a presentation was given on the results from the energy audit. Twenty three copies of technical working paper #93 were requested by those attending this conference.

In all, twelve technical working papers were written under this STP. One hundred and twenty four copies of these technical working papers have been requested by various people associated with the thermal processing industry. Appendix 4.2 shows the distribution of technical working papers by title as functions of time.

4.0 Appendix

- 4.1 Technical Working Papers
- 4.2 Distribution List of TWP
- 4.3 Time and Event and Mile stones
- 4.4 Hardwareand Software Supplier Addresses
- 4.5 Hardware and Software Specifications

Appendix 4.1 - List of Technical Working Papers

- TWP#38 Optimizing Retort Sterilization Process: Industry Survey
- TWP#39 Optimizing Retort Sterilization Process Literature Review "Critical Processing Parameters: Heating Media, Rotation Speed, Rack Design"
- TWP#42: Optimization Retort Sterilization Process: "Process Control Sterilization Technology Symposium 1991 ASAE International Winter Meeting".
- TWP#45 Optimization Retort Sterilization Process. Literature Review: Food Quality Attributes Used as an Indicator of Impact of Thermal Process on Quality on of Canned Food
- TWP#55 Development of Numerical Food Quality Index for Evaluation of Retort Processes.
- TWP#67: Development of Methodology for Conducting and Analyzing Temperature Distribution Studies for Evaluation of Retort Processes.
- TWP#71 Optimization Retort processes: Electronic Literature Data base
- TWP#74: Effects of Heating Media, Rack Design and Rotational Speed on Lethality and Quality of Food in Half-team Table Trays.
- TWP#76 Effects of Heating Media, Rack Design and Rotational Speed on Lethality and Quality of Food in MRE Pouches.
- TWP#77 Energy Auditing of Retort Processes
- TWP#91 Lethality and Quality in a Model Canned Food System as Influenced by Heating Exchange Medium, Rack Spacer Clearance and Agitation in a Batch Retort Sterilization Process.
- TWP#93 Multi Variable Optimization of Retort Processes

Copies of the above Technical Working Papers can be requested by contacting CRAMTD at (908) 445-6130 or writing to:

CAFT/CRAMTD
Food Manufacturing Technology Facility
120 New England Avenue
Piscataway, NJ 08854

Appendix 4.2: Distribution of Technical Working Papers

The following table indicates by month, the distribution of technical working papers based on industry requests.

**Fig 1 - CRAMTD Short Term Project #6
Optimizing Retort Sterilization Process
Projected Time Events and Milestones**

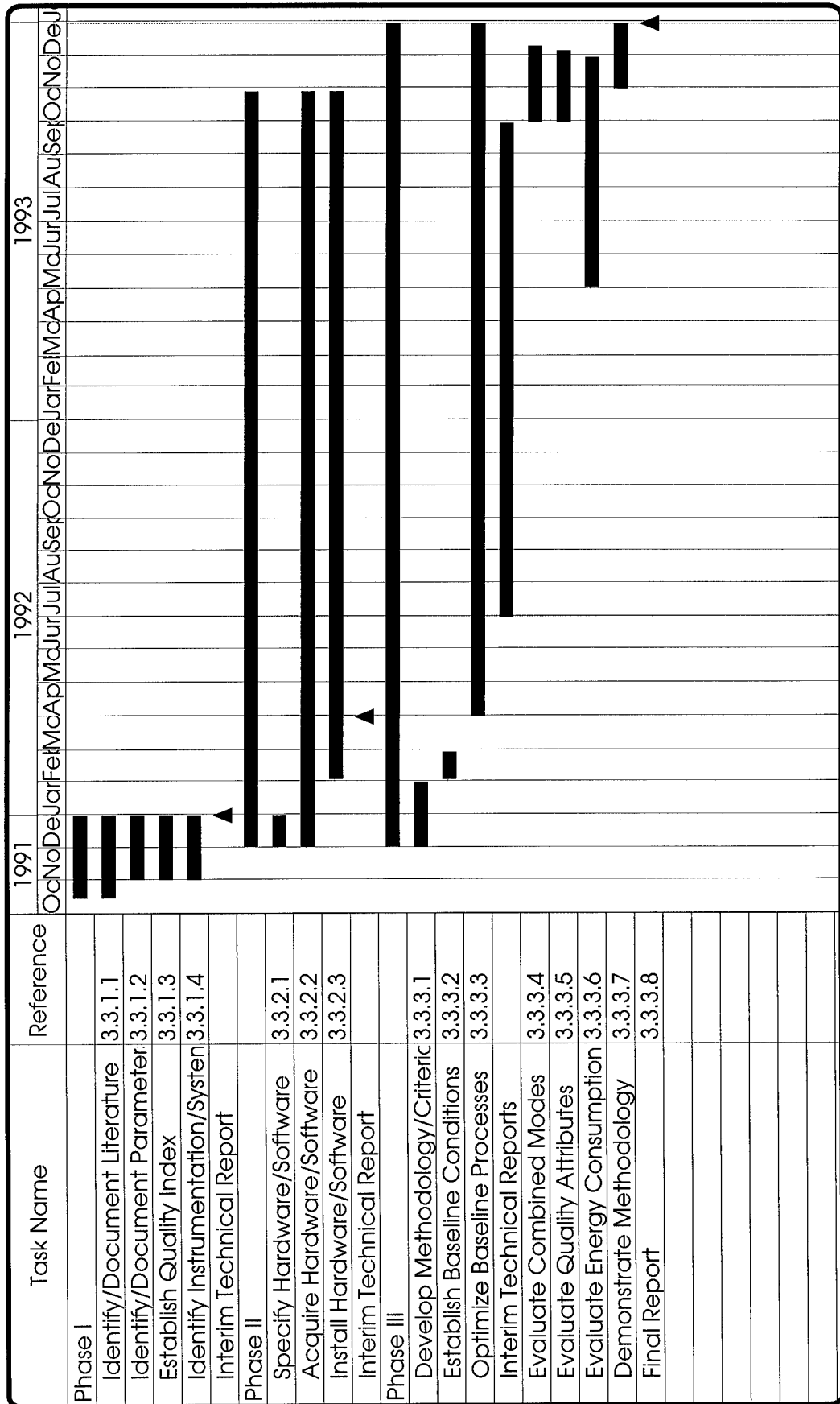

Appendix 4.4 -Hardwareand Software Supplier Addresses

Adjustable Racks for MRE pouches
RetroTEC, Inc.
2236 Suite B Bluemound Road
Waukesha, WI 53186
Tel: (414) 798-0277

DART:
Anderson Instrument Co., Inc.
156 Auriesville Road
Fultonville, N.Y.12072
Tel: 518-922-5315

KW Meter:
OHIO Semitronics, Inc
1205 Chesapeake Avenue
Columbus, OH 43212
Tel: (614) 486-9561

NumeriCAL:
TechniCAL, Inc.
3850 N. Causeway Boulevard, Suite 830
Metairie, LS 70002
Tel: 504-836-2222

Steam Flow Meter, Water Flow Meter & Air Flow Meter
Omega Engineering, Inc.
One Omega Drive, Box 4047
Stanford, CT 06907
Tel: (203) 359-1660

Stock RCU 1/1100 Retort, Counter Pressure Profiler & Half Steam Table Tray Retort Racks:
Stock America Inc.
3808 West Elm Street
Milwaukee, WI 53209
Tel: 414-351-7900

Appendix 4.5 -Hardware and Software Specifications

- 1) Counter Pressure Profiler (page 2)
- 2) Steam Flow Meter (page 3-5)
- 3) Water Flow Meter (page 6-8)
- 4) Air Flow Meter (page 9-11)
- 5) Adjustable Racks for MRE Pouches (page 12-21)



STOCK America Inc.

3808 West Elm Street
Milwaukee, Wisconsin 53209
Telephone: (414) 351-7900

PROPOSAL

Page 1 of 1 Pages

To CAFT/RUTGERS STATE UNIVERSITY OF NJ Proposal No. SED-303-92

Address P.O. Box 231, Cook College, New Brunswick NJ 08903 Date February 5, 1992

SUBJECT CEP-200 II

Attn: Mr. Rieks Bruins

We Are Pleased To Offer The Following For Your Consideration:

CEP-200 II Container Shape Pressure Profiler -

Stock CEP-200 Container Shape Pressure Profiler is the answer to costly deformation of metal or thin wall aluminum cans and semi-rigid or flexible plastic containers.

Through the use of a sophisticated electronic sensor, expansion or contraction of a container can be monitored within 0.10 millimeters during a production retort cycle. This permits the establishment of the optimum counterpressure profile for a container under precisely defined conditions, including headspace and fill variables. This proven system also provides control capabilities, both manual and automatic, through an interface with system pressure control valves. Analog output of 0-10V and 0-20V are also provided for direct connection of dataloggers or chart recorders.

SPECIAL PRICE:

CEP-200 II Container Shape Pressure Profiler.....\$ 9,850.00

FOB Milwaukee, WI, freight allowed prepaid and to Job site, unloading by others. to be added

Current Characteristics _____ Approx. Shipping Weight _____

Payment Terms To be determined Approximate Shipment after Receipt of Order and Complete Details in Milwaukee 1-2 weeks

Stock America, Inc. ("Company") offers to furnish the Equipment described herein for the purchase price noted, exclusive of all taxes. Prices quoted are firm for 30 days from date of Proposal but are subject to adjustment in accordance with the provisions of paragraph 1 (c) on the reverse side. This Proposal is subject to withdrawal at any time without notice and any contract resulting from this Proposal is subject to acceptance by the Company at Milwaukee, Wisconsin. No statements or understandings relating to the subject matter, other than those set forth herein, shall be binding on the Company.

THE TERMS AND CONDITIONS OF SALE ON THE REVERSE SIDE ARE PART OF THIS PROPOSAL

PROPOSAL FURNISHED BY:

Date ACCEPTED _____ 19 _____

Please return one signed copy of this proposal or your purchase order referenced to this proposal number and date to "Stock America, Inc." in care of your Stock America Sales Represen-

STOCK ELECTRONICS DIVISION

Kimbel A. Nap
Kimbel A. Nap

By _____

THE STATE UNIVERSITY OF NEW JERSEY
RUTGERS

Interdepartmental Communication

CRAMTD

January 14, 1992

TO: Mike Dunn
Purchasing Department

FROM: Rieks Bruins *RB*
Manager, Process Development

RE: Steam Flow Monitoring System

Under the CRAMTD contract, Short Term Project (STP) #6, we need to identify, acquire and install an energy monitoring system for the utilities used in the retort process. The utilities in question are: steam, water and electricity. This particular memo specifies the requirements for the steam flow monitoring system. For your benefit, I have attached the description of a system marketed by OMEGA Engineering.

Please review our requirements and solicit competitive quotes in accordance to Rutgers approved purchasing procedures. If you have any questions, give me a call at 932-8307

RB:d

cc: J. Coburn
J. Rossen
W. Sznajdrowska

-2-

Steam Flow Monitoring System**Description Environment:**

Steam Pipe size:	2 inch diameter
Steam Pressure:	150 psig max 90 psig nominal
Steam flow:	1800 lb/hr max 200 lb/hr nominal
Steam quality:	saturated

Requirements:

Sensor Construction:	Flange mounted, Nema 4
Display:	Flow rate [BTU/hr] Accumulated flow [BTU]
Accuracy of sensor output:	+/- 1% or better

Optional:

Output signal for external datalogger: 4-20 mA

Time schedule for acquisition:

Installation: March 1

>>>>>> Q U O T A T I O N <<<<<<<<

OMEGA ENGINEERING, INC.
 One Omega Drive, Box 4047, Stamford, CT 06907-0047
 (203)359-1650 TELEX: 996404 CABLE: OMEGA FAX (203)359-7700

CENTER FOR ADVANCE FOOD TECH
 P O BOX 231
 NEW BRUNSWICK NJ 08903

Date	09/23/92
Quote No.	Q209921553
Your No.	BRUINS

FAX To RIEKS BRUINS
 FAX No. (908)932-8690

In response to your inquiry we are pleased to submit the following:
 (Terms) NET 30 Pending credit approval (F.O.B.) STAMFORD

Item No.	Qty	Description	Est. Ship Date A.R.O.	Net Unit Price	Total Amount
1)	1	FV-515G-P VORTEX METER, GAS-1.5" FMF	8 Week	1,956.00 EA	1,956.00
2)	1	FC-20-MA MASS FLOW COMPUTER	6 Week	805.00 EA	805.00
3)	1	PR-12-2-100-1/4-3-E CAST IRON HEAD 100 OHM RTD	2 Week	90.00 EA	90.00
4)	1	EXTT-4CU-26S-50 TEFLON INSULATED EXTENSIONWIRE	1 Week	70.00 SP	70.00
5)	1	PX880-300GI PRESSURE TRANSMITTER	2 Week	695.00 EA	695.00

THIS QUOTATION IS VALID FOR 30 DAYS TOTAL AMT 3,616.00

Please refer to the OMEGA QUOTE# Q209921553 when placing this on order.

FAX From JESSE SAMS

Omega Engineering, Inc. offers this quotation in accordance with published terms, conditions, limited liability, and warranty statements as reflected in Omega handbooks. Omega cannot be held responsible for customer imposed requirements unless agreed to in writing in the body of this quotation.

THE STATE UNIVERSITY OF NEW JERSEY
RUTGERS

Interdepartmental Communication

CRAMTD

April 8, 1992

TO: Mike Dunn
FROM: Rieks Bruins RB
RE: Water Flow Monitoring System

Under the CRAMTD contract, Short Term Project #6, we need to identify, acquire and install an energy monitoring system for the utilities used in the retort process. The utilities in question are: steam, water and electricity. This particular memo specifies the requirements for the water flow monitoring system.

Please review our requirements and solicit competitive quotes in accordance to Rutgers approved purchasing procedures. Attached is a quote from Omega for a system which meets my specification (without 4-20ma output signal) You can use this quote in your evaluation. If you have any questions, give me a call at Ext. 8307.

RB:d

cc: John Coburn
Jack Rossen

-2-

Water Flow Monitoring System**Description Environment:**

Water Pipe Size:	2 inch diameter
Water Pressure:	80 psig max 60 psig nominal
Water flow:	90 GPM max 60 GPM nominal
Water Temperature:	40-70 F

Requirements:

Sensor Construction:	Nema 4
Display:	Flow rate [GPM/hr] Accumulated flow [GAL]
System Accuracy:	+/- 2% of reading

Optional:

Output signal for external datalogger: 4-20 mA liniair to flow rate

Time schedule for acquisition:

Installation: May 15

23SEP92 14:27 FROM 62968934 9081839L TO 9089328690

VIA AT&T EASYLINK

PAGE 1 OF 1

>>>>>> Q U O T A T I O N <<<<<<<<

OMEGA ENGINEERING, INC.
 One Omega Drive, Box 4047, Stamford, CT 06907-0047
 (203)359-1660 TELEX: 996404 CABLE: OMEGA FAX (203)359-7700

CNTR.ADV.FOOD TECH.
 PO BOX 231
 NEW BRUNSWICK NJ 08903

Date	09/23/92
Quote No.	Q209922163
Your No.	MAJ092392

FAX To RICKS BRUINS
 FAX No. (908)932-8690

In response to your inquiry we are pleased to submit the following:
 (Terms) NET 30 Pending credit approval (F.O.B.) STAMFORD

Item No.	Qty	Description	Est. Ship Date	A.R.O.	Net Unit Price	Total Amount
1)	1	FP-5800 FLOW XMITTER-CAL FOR FITTING	1	Week	475.00 EA	475.00
2)	1	FP-5320CU COPPER FITTING - 2"	1	Week	126.00 EA	126.00
3)	1	DPF66 RATEMETER & BATCH CONTROLLER	1	Week	375.00 EA	375.00

THIS QUOTATION IS VALID FOR 30 DAYS

TOTAL AMT 976.00

Please refer to the OMEGA QUOTE# Q209922163 when placing this on order.

+ Cable Tx4-100 28.50
 FAX From
 + shipment.

Omega Engineering, Inc. offers this quotation in accordance with published terms, conditions, limited liability, and warranty statements as reflected in Omega handbooks. Omega cannot be held responsible for customer imposed requirements unless agreed to in writing in the body of this quotation.

THE STATE UNIVERSITY OF NEW JERSEY
RUTGERS

PO-R 92020

Interdepartmental Communication

Food Mfg. Technology Facility
120 New England Avenue
Piscataway, Busch Campus

July 13, 1993

TO: Mike Dunn
Purchasing Department

FROM: Rieks Bruins *MBB*
Manager, Process development

RE: Air Flow Monitoring System

Under the CRAMTD contract, Short Term Project (STP) #6, we need to identify, acquire and install energy monitoring systems for the utilities used in retort processing. This particular memo specifies the requirements for the air flow monitoring system. For your benefit, I have obtained a quotation for a complete system marketed by OMEGA Engineering.

Please review our requirements and solicited quotation. We request sole source for this purchase as it will be integrated in an existing flow monitoring system previously supplied by Omega Engineering (water monitoring system) and use will be made of a common component (DPF66 batch monitor and controller). If you have any questions, please give me a call at 5-6135.

cc: J.Coburn
L.Contreras

-2-

Air Flow Monitoring System

Description Environment:

Air Line size:1 inch diameter

Air Pressure:150 psig max

Air Flow:5000 standard feet per minute max

Requirements:

Display:Flow rate [scfm]

& accumulated flow [standard cubic feet]

Accuracy of sensor output:+/- 1% Full scale

Output requirements:4-20 ma signal for external data logger

>>>>>> Q U O T A T I O N <<<<<<<

OMEGA ENGINEERING ,INC.

One Omega Drive, Box 4047, Stamford, CT 06907-0047
 (203)359-1650 TELEX: 996404 CABLE: OMEGA FAX (203)359-7702

CAFT
 908-445-6135
 PISCATAWAY NJ 08854

Date	07/12/93
Quote No.	Q307900314
Your No.	MAJ071193

FAX To RICKS BRUINS
 FAX No. (908)445-6145

In response to your inquiry we are pleased to submit the following:
 (Terms) NET 30 Pending credit approval (F.O.B.) STAMFORD

Item No.	Qty	Description	Est. Ship Date	A.R.O.	Net Unit Price	Total Amount
1)	1	FMA-605-V AIR VEL.TRANSDUCER-0/5000FPM	1	Week	822.00 EA	822.00
2)	1	FPW-15 +15VDC 400MA POWER SUPPLY	1	Week	75.00 EA	75.00
3)	1	DPF64-A FLOW METER	1	Week	330.00 EA	330.00
4)	1	OCW-1 OMEGA CARE WARRANTY 1 YEAR	1	Week	33.00 EA	33.00
5)	1	BRLK-14-14 1/4 X 1/4 COMPRESSION FITTING	1	Week	3.00 EA	3.00
6)	1	FMA-C50 50 FT.CABLE SET FOR 0/5VOLT	1	Week	165.00 EA	165.00

Need Quantity Monitor

THIS QUOTATION IS VALID FOR 30 DAYS TOTAL AMT 1,429.00

Please refer to the OMEGA QUOTE# Q307900314 when placing this on order.

FAX From MEL JOHNS EX 2283

Omega Engineering, Inc. offers this quotation in accordance with published terms, conditions, limited liability, and warranty statements as reflected in Omega handbooks. Omega cannot be held responsible for customer imposed requirements unless agreed to in writing in the body of this quotation.

PLEASE FEEL FREE TO CALL IF THERE ARE ANY QUESTIONS OR IF FURTHER INFORMATION IS REQUIRED.

REGARDS

MEL JOHNS

PLEASE CALL OR FAX ORDER TO MEL JOHNS FAX# (203)359-7990



CENTER FOR
ADVANCED
FOOD
TECHNOLOGY

Combat Rations Advanced Manufacturing Technology Demonstration
(GRAMTD)/FoodTEX Programs
908/932-8307

March 2, 1992

414-798-0277

Mr. Henry E. Cathers, Jr.
RetorTec, Inc.
2236 Suite B Bluemound Road
Waukesha, WI 53186

Dear Mr. Cathers:

Attached is a Request for Proposal for a MRE rack design which we need to evaluate within the context of a retort optimization project. Within this project, we will be using various retort heating modes and use various retort agitation speeds. It is our experience that due to these different heating modes, the space between the pouches has to be adjusted to obtain adequate temperature distribution. Because of your expertise in the area of retort rack design for MRE pouch, we would like to solicit a proposal from you for the design and manufacturing of a complete set of racks for our Stock 1/1100 retort which could address the issue of how much space is required between the pouches as function of the heating mode.

Please give me a call if you have any questions regarding the Request for Proposal.

Sincerely,

Rieks Bruins
Manager, Process Development

RB:d

cc: J. Rossen
J. Coburn
T. Descovich
M. Dunn

Nabisco Advanced
Food Technology Institute
Cook College
P O Box 231
New Brunswick NJ 08903-0231
908/932-8306

REQUEST FOR PROPOSAL

CRAMTD is executing a Short Term Project under the CRAMTD program called "Optimizing Retort Sterilization Process". One of the objectives in this project is to evaluate various rack designs as function of retort heating mode and retort agitation speed. One of the products which is emphasized during this project is the MRE pouch, which is formed, filled and sealed on our horizontal form, fill, seal line.

CRAMTD feels that two important parameters in thermal stabilization are directly determined by the rack design. These two parameters are:

- 1) Uniform temperature distribution during the retort process. We feel that the open space between the pouches is the primary rack variable which affects this uniformity. However, this variable also affects the number of pouches which can be processed per batch and excessive open area between the pouch will lead to uneconomic conditions.
- 2) Rack/pouch interaction during the retort process, causing pouch defects such as tear, cut, hole or abrasion through one or more layers of the pouch material. Proper design of the pouch cavity and/or use of protective coatings on the rack can minimize/reduce the pouch defects due to retorting.

CRAMTD is requesting proposals for a set of racks which comply with the following criteria/restrictions:

- * One set of racks with adjustments in open (unrestricted) space between pouches (3, 5 & 7 mm), or if more economic: three sets of racks with various open space
- * Can accept the MRE pouch made on the CRAMTD horizontal form fill seal machine (dimension supplied on page 2)
- * Restricts the pouch to a maximum thickness of 1 inch during retorting
- * Protects the pouch against tears, cuts, holes or abrasion or other defects during retorting at various retort rotational speeds (0-24 rpm)
- * Can withstand various retort heating modes with retort temperature up to 280 F
- * Are sturdy enough to be handled by automatic rack loading and unloading equipment
- * Fit within the retort crate (Dimension supplied on page 2)
- * Fill the retort crate to the maximum (Dimension supplied on page 2)
- * Delivery of the racks are expected four weeks after issue of purchase order
- * Terms of purchase will be in accordance with Rutgers policies.

-2-

All proposals for this rack design will be held confidential unless a particular proposal is being awarded at which time it becomes part of the CRAMTD demonstration line.

MRE Pouch Dimension:

Length: 208.4 mm

Width: 121.3 mm

Depth: 25.4 mm (max.); 15.9 mm (min.)

Retort Crate Design

Depth: 30.5 inches

Width: 27.0 inches

Height: 27.0 inches

THE STATE UNIVERSITY OF NEW JERSEY
RUTGERS

Interdepartmental Communication

CRAMTD

April 3, 1992

TO: Mike Dunn
Purchasing Department

FROM: Rieks Bruins *HBB*
Manager, Food Process Development

RE: MRE Pouch Racks

Two quotations were received by me for a rack design for MRE pouch product. The letter detailing the request for proposal as well as the two received proposals are attached. Both proposals are satisfactory. The RetroTEC proposal has a slightly longer delivery time than requested but due to a delay in the research project, I find that this longer delivery time not objectionable. After careful evaluation of both proposals I recommend to award the purchase order to RetroTEC, Inc. My reasons for this are as follows:

1) RetroTEC's design is based on flexibility, both the space for the pouch as well as the space between the pouch can be adjusted. This design feature is beneficial to us as it allows us to test many more combinations than originally specified.

2) The design from RetroTEC appears to be give more support to the racks by utilizing bar stock in between the plates. Because Stock did not supply us with a detailed engineering drawing of their rack design, I called them to obtain more specific information on design features. Based on these discussions I determined that the design by Stock relies on angle iron on the perimeter to maintain space between the top and bottom plate of each rack and no support is provided in the middle of the racks. Potentially, the plates might bend due to product expansion and reduce the critical open space between these plates.

3) The price difference between the Stock design and the RetroTEC design is minimal (\$8,760 versus \$8,800). In the Stock design, we need to purchase 60 (22+20+18) racks. The RetroTEC requires 25 racks with additional spacers. The price per unit is \$350.00/rack for the RetroTEC racks and the Stock racks are \$146.00/rack.

4) The delivery time of the RetroTEC racks is longer than requested, but as stated previously, as long as we would receive the racks before the end of May, I do not foresee delays in the projects.

MRE Pouch Racks
April 3, 1992

-2-

5) The payment schedule of RetroTEC requires 50% with the purchase order. I discussed this with RetroTEC and they are willing to adjust this as long as Rutgers could make payment of incurred cost in case of cancellation. I told him that this would be the decision of the Rutgers purchasing department.

Please give me a call if you have any questions regarding the above. In the meantime, I will proceed with the request for purchase via the CAFT office.

RB:d

cc: John Coburn
Kristin Danner
Candace Grace
Jack Rossen

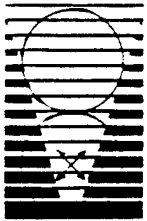

RetroTEC, INC.

FOOD PROCESSING EQUIPMENTS

"TURNING THE INDUSTRY AROUND"

March 17, 1992

Rieks Bruins
 CRAMTD
 P.O. Box 231
 New Brunswick, NJ 08903

Dear Rieks,

Please find enclosed our proposal and concept drawings for your requested adjustable rack. Please notice that this rack can be adjusted through three different pouch thickness (5/8, 3/4 and 1") and through three different height adjustments between the pouch pockets (1/8, 1/4 and 3/8"). The plates and bars will be constructed so the bars can be turned from side to side or front to back in order to see the effect on flow. (Water should be from side to side and steam-air from front to back).

I have chosen bar stock for the spacer plates because they are easier and faster to work with. When they travel with the flow there should be no interference and you can test the effect of when they're against the flow. Each rack will have the pieces necessary for all combinations and will be quickly assembled by stainless steel screws on top and bottom. We picture eight (8) screws per side. The plates will always remain coupled to the frame and will not need to be separated. The pockets will be close fitted to your pouch as we now have received samples.

Should you require clarification or additional information please feel free to call me at (414) 798-0277. I look forward to being of further assistance and wish you the best with your project.

Sincerely Yours,

RetroTEC, Inc.

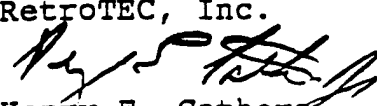
 Henry E. Cathers
 President

HEC/csc

Enclosure

SPACER A-.0625, .1250, OR .2500
SPACER B-.2500, .3750, OR .5000

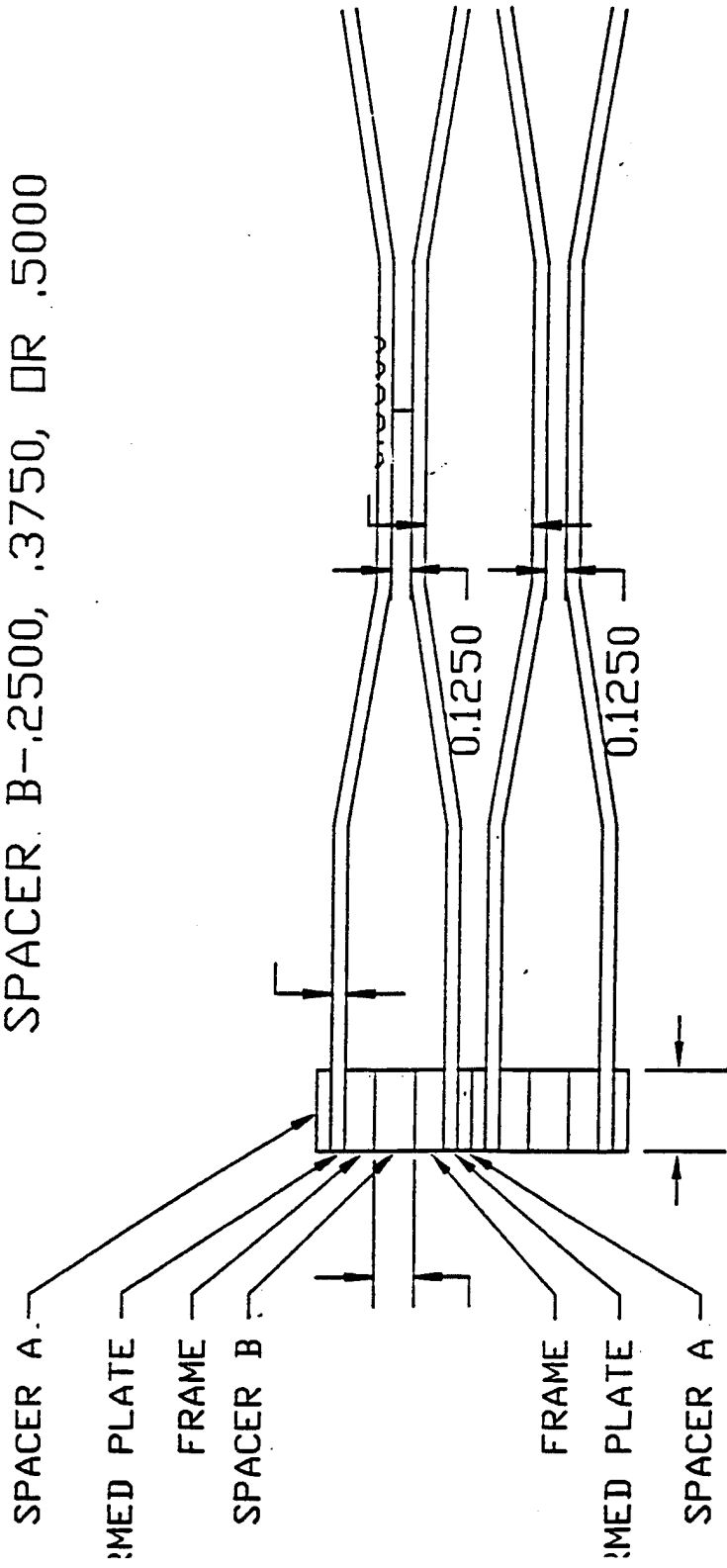

SPACER BAR A
POUCH HEIGHT ADJ.



FORMED PLATE



FRAME



SPACER BAR B
POCKET HEIGHT ADJ.

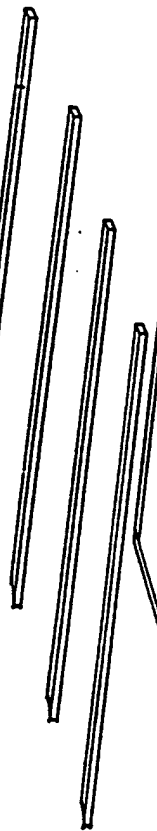

		RetroTEC, Inc. 22368 Bluemound Rd. Waukesha, WI 53186 (414) 798-0277 Fax: (414) 798-0255	
SCALE NOT TO SCALE	DATE	REVISED BY	REVISION NUMBER
	3/12/92	CPC	VER 1.0

DRAWING NUMBER FRAME2

