

ARMY RESEARCH LABORATORY



A General Purpose Prototype Muffler
for the Bradley Fighting Vehicle
25-mm Automatic Cannon
Fitted With Standard Barrel

Kevin S. Fansler
James M. Garner

ARL-MR-243

July 1995

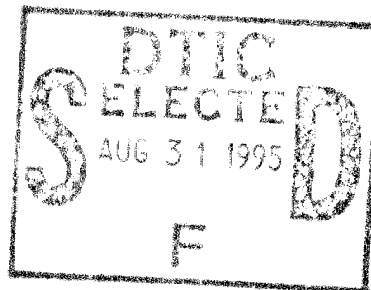

19950830 081

APPROVED FOR PUBLIC RELEASE; DISTRIBUTION IS UNLIMITED.

FORM QUALITY INSPECTED 8

NOTICES

Destroy this report when it is no longer needed. DO NOT return it to the originator.

Additional copies of this report may be obtained from the National Technical Information Service, U.S. Department of Commerce, 5285 Port Royal Road, Springfield, VA 22161.

The findings of this report are not to be construed as an official Department of the Army position, unless so designated by other authorized documents.

The use of trade names or manufacturers' names in this report does not constitute endorsement of any commercial product.

REPORT DOCUMENTATION PAGE

Form Approved
OMB No. 0704-0188

Public reporting burden for this collection of information is estimated to average 1 hour per response, including the time for reviewing instructions, searching existing data sources, gathering and maintaining the data needed, and completing and reviewing the collection of information. Send comments regarding this burden estimate or any other aspect of this collection of information, including suggestions for reducing this burden, to Washington Headquarters Services, Directorate for Information Operations and Reports, 1215 Jefferson Davis Highway, Suite 1204, Arlington, VA 22202-4302, and to the Office of Management and Budget, Paperwork Reduction Project(0704-0188), Washington, DC 20503.

1. AGENCY USE ONLY (Leave blank)

2. REPORT DATE
July 1995

3. REPORT TYPE AND DATES COVERED
Final, August 1993 - December 1994

4. TITLE AND SUBTITLE

A General Purpose Prototype Muffler for the Bradley Fighting Vehicle 25-mm Automatic Cannon Fitted With Standard Barrel

5. FUNDING NUMBERS

WO#: 4G031441R5

6. AUTHOR(S)

Kevin S. Fansler and James M. Garner

7. PERFORMING ORGANIZATION NAME(S) AND ADDRESS(ES)

U.S. Army Research Laboratory
ATTN: AMSRL-WT-PB
Aberdeen Proving Ground, MD 21005-5066

8. PERFORMING ORGANIZATION REPORT NUMBER

ARL-MR-243

9. SPONSORING/MONITORING AGENCY NAMES(S) AND ADDRESS(ES)

10. SPONSORING/MONITORING AGENCY REPORT NUMBER

11. SUPPLEMENTARY NOTES

12a. DISTRIBUTION/AVAILABILITY STATEMENT

Approved for public release; distribution is unlimited.

12b. DISTRIBUTION CODE

13. ABSTRACT (Maximum 200 words)

In response to complaints at German Training Areas (GTA) about firing noise generated by the 25-mm M242 chain gun that is mounted on the Bradley Fighting Vehicle (BFV), a prototype muffler for use with all types of ammunition was designed, fabricated, and performance-tested against requirements given by an Operational Needs Statement. This muffler was designed for use with the standard M242 barrel. As such, the muffler consisted of a muffler shell that screwed on a perforated extension tube. Tests included noise attenuation and projectile dispersion. Noise requirements were not only met but also exceeded. Dispersion testing of M793 and M910 ammunition showed that the barrel/muffler system, when attached loosely to the barrel, did not perform as well as the standard barrel/brake system. Nevertheless, testing with other mufflers that were held tightly to the barrel showed no degradation of the dispersion pattern. Further testing is needed with a muffler tightly held on the barrel.

14. SUBJECT TERMS

noise reduction, guns, impulse noise

15. NUMBER OF PAGES

22

16. PRICE CODE

17. SECURITY CLASSIFICATION OF REPORT

UNCLASSIFIED

18. SECURITY CLASSIFICATION OF THIS PAGE

UNCLASSIFIED

19. SECURITY CLASSIFICATION OF ABSTRACT

UNCLASSIFIED

20. LIMITATION OF ABSTRACT

SAR

INTENTIONALLY LEFT BLANK.

ACKNOWLEDGMENTS

ARDEC provided the funding and also gave consultative assistance. In particular, Mr. James Donham assisted in the testing at Grafenwoehr Training Area, Germany. Personnel at Combat Systems Test Activity (CSTA) were very helpful in conducting the required tests. Mr. Gerald Steier served very capably as the test director for the work at CSTA. These tests could not have been performed without the assistance of Mr. Donald McClellan, a contractor from LB&B. We also thank Dr. Edward Schmidt, the Aerodynamic Branch Chief from ARL, for technical and general advice.

Accession For	
NTIS CRA&I	<input checked="" type="checkbox"/>
DTIC TAB	<input type="checkbox"/>
Unannounced	<input type="checkbox"/>
Justification	
By	
Distribution/	
Availability Codes	
Dist	Avail and/or Special
A-1	

INTENTIONALLY LEFT BLANK.

TABLE OF CONTENTS

	<u>Page</u>
ACKNOWLEDGMENTS	iii
LIST OF FIGURES	vii
LIST OF TABLES	vii
1. INTRODUCTION	1
2. EXTENSION OPTIMIZATION EXPERIMENTS AND ANALYSIS	1
3. MUFFLER DESIGN AND TESTING	5
3.1 Dispersion Testing.	6
3.2 Noise Attenuation Test and Results.	7
4. TESTS AT GRAFENWOEHR TRAINING AREA, GERMANY	8
5. SUMMARY AND CONCLUSIONS	9
6. REFERENCES	11
APPENDIX: DETAILED TARGET DISPERSION VALUES	13
DISTRIBUTION LIST	17

INTENTIONALLY LEFT BLANK.

LIST OF FIGURES

<u>Figure</u>		<u>Page</u>
1.	Decision Chart for Barrel Extension Tests.	2
2.	Slotted Barrel Extension	4
3.	Holed Barrel Extension	5
4.	Muffler Shell with Barrel Extension Tube	6

LIST OF TABLES

<u>Table</u>		<u>Page</u>
1.	Root-Mean-Square Comparisons for Unperforated Barrel Extensions	3
2.	Root-Mean-Square Comparisons for Perforated Barrel Extensions.	4
3.	Root-Mean-Square Comparison between Muffler and Standard Brake.	7
4.	Noise Attenuation Referenced with Brake - dB-Peak.	7
5.	Dispersion Comparisons (mils) for Unperforated Barrel Extensions.	15
6.	Dispersion Results (mils) for Perforated Barrel Extensions.	16
7.	Dispersion Results (mils) for Muffer with Slotted Barrel Extension.	16

INTENTIONALLY LEFT BLANK.

1. INTRODUCTION

Residents of villages bordering German Training Areas (GTA) in Germany have long complained of excessive noise from gun firings. The suggested levels should be within the limits given by the Committee for the Application of Measurement Techniques (1987) unless a special waiver is given, such as, to meet military requirements (Fansler et al. 1992). The Bradley Fighting Vehicle (BFV), when firing the M242 25-mm chain gun, has been identified as a generator of excessive impulsive noise. Tests with a muffler that could only fire unsaboted rounds (M793) showed that a significant noise reduction could be achieved (Lewis 1988; Fansler and Lyon 1989). An Operational Needs Statement (ONS) describing the performance requirements for a muffler capable of firing both M793 and sabot training rounds (M910) was issued in 1989. The muffler should reduce the noise by at least 10 dB, be safe, durable, and yet have the same performance as the standard barrel/brake combination.

In response to the ONS, the U.S. Army Research Laboratory (ARL) designed and fabricated two prototype mufflers for use with all types of ammunition (Fansler et al. 1992). One of the mufflers met the requirements for reducing noise and was further tested against the ONS requirements. This more effective muffler required the use of a special long barrel with perforations placed near the muzzle. In 1993, the barrel/muffler was brought to the Grafenwoehr Training Area in Germany to demonstrate its noise reduction and accuracy capabilities.

Following this test, the Army Materiel Command-Field Assistance in Science and Technology (AMC-FAST) office provided funding to the U.S. Army Armament Research, Development, and Engineering Center (ARDEC) to develop a muffler that could be used with a standard barrel, thus saving the cost of developing and producing a new type of barrel. ARDEC, in turn, sent ARL the funds to start development of the muffler. This report describes the experiments, design efforts, and tests performed to develop a muffler for the standard barrel.

2. EXTENSION OPTIMIZATION EXPERIMENTS AND ANALYSIS

Originally, three muzzle extensions were fabricated to approximate the mass of a projected muffler system. After preliminary tests, the muzzle extensions could be machined down and modified to be used with a muffler shell. Their initial masses were approximately 8.18 kg (18 lb) and projected to be equal to the mass of the final muffler system. These extensions have smooth bores and depend upon the inertia of the projectile for maintaining

its spin angular velocity through the extension length. The groove-to-groove diameter of the standard barrel is 2.635 cm (1.025 inches). One extension was made with a bore diameter of 2.563 cm (1.009 inches), the second extension's bore diameter was 2.635 cm (1.025 inches) near the muzzle and then tapered down to 2.543 cm (1.009 inches), and the third extension's bore diameter was 2.635 cm (1.025 inches). The barrel extension whose bore tapered down was also referred to as the squeeze-bore barrel extension while the 2.635-cm (1.025 inches) bore-diameter barrel was referred to as straight. A decision tree to dispersion test and select the best extension configuration was constructed as shown in Figure 1.

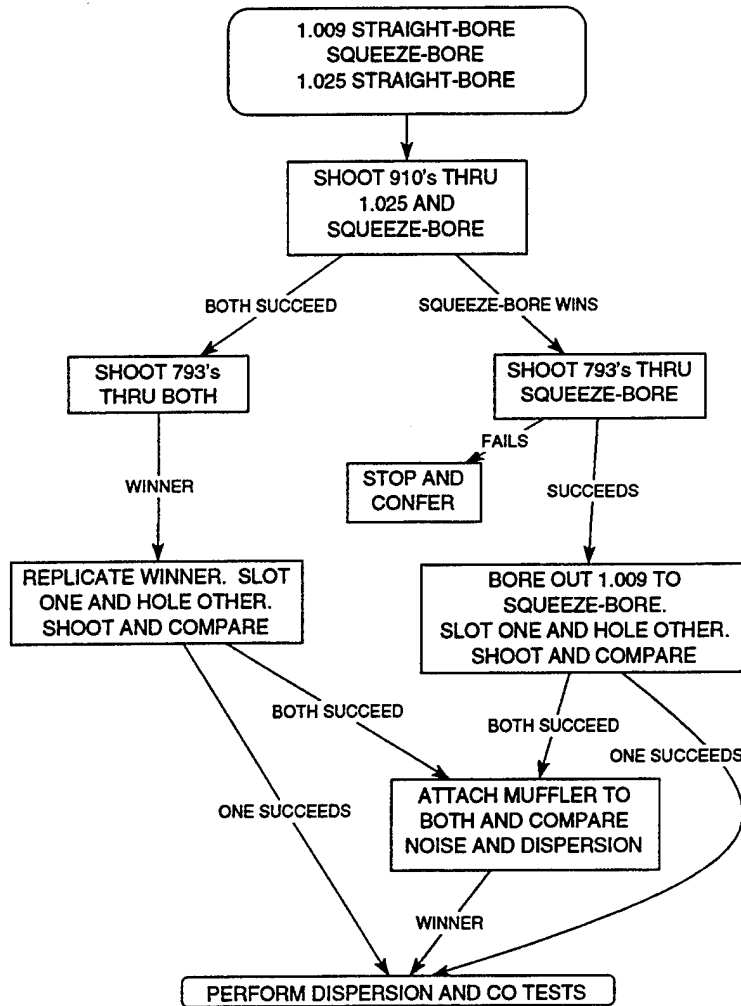

Figure 1. Decision Chart for Barrel Extension Tests.

To measure dispersion, 10 rounds were fired single shot at a target using M910 TPDS-T and M793 TP-T ammunition. The M793 ammunition is described as Lot No. AJD88J101-002, and the sabot M910 ammunition is Lot No. ATJ93B292-002. The barrel used is the

first production model of a new heavier ribbed design and has the serial number 001. The brake used is the new production model designed to be used with the new version of the standard barrel. This brake is shorter than the old standard brake and vents out to the sides in three planes instead of one plane. For supplementary information about these tests refer to another report (Steier 1994).

To obtain statistically meaningful results, five targets were used for each combination of extension or brake and each type of ammunition. The targets centered in a 1.83-m square Oehler Acoustic Firing System located 200 m downrange from the gun. The detailed dispersion results are given in the Appendix, but the root mean square of the standard deviation (SD) dispersion data in the Appendix gives the results shown in Table 1. The value of σ_x refers to the lateral component of the SD while the value of σ_y refers to the vertical component of the SD. Most of these results are for five targets, but one or two of the values were obtained for four targets because of equipment malfunction.

Table 1. Root-Mean-Square Comparisons for Unperforated Barrel Extensions (Bore Diameter of Straight Extension is 2.604 cm).

Ammo Type	Brake			Straight			Squeeze		
	σ_x	σ_y	σ_r	σ_x	σ_y	σ_r	σ_x	σ_y	σ_r
M793	0.28	0.33	0.43	0.35	0.37	0.51	0.40	0.43	0.59
M910	0.46	0.40	0.61	0.42	0.35	0.54	0.31	0.26	0.41

When the sabot M910 ammunition is used, the squeeze-bore extension improves the dispersion significantly over both the brake-equipped barrel and straight-bore extension. It is not known why the dispersion pattern is improved significantly; perhaps the smaller bore diameter reduces clearance between projectile and bore surfaces, thereby decreasing lateral movement and angular transverse velocity and thus reducing the aerodynamic jump. The squeeze-bore extension, however, gives the worse dispersion for the unsaboted M793 ammunition. Again, no convincing explanation has been given for the behavior.

The straight-bore extension that was bored out to 2.604 cm (1.025 inches) was chosen since it performed similarly to the brake-equipped barrel and was easier and cheaper to manufacture. The machine shop bored holes in the original straight-bore extension. The squeeze-bore extension was machined out to 2.591 cm (1.020 inches), and slots were installed.

These two barrel extensions were again field tested to determine if the added perforations might increase the dispersion of the M910 round. Perhaps the perforated portion of the tube

might allow the sabot petals to loosen their grip on the subprojectile and, as discussed before, the aerodynamic jump might increase. Because the original lot had been completely used, the M793 ammunition was changed to lot number PFC83K127H0LL. The M910 ammunition lot number was unchanged. The detailed dispersion results are given in the Appendix. The root-mean-square values for this detailed dispersion data are given in Table 2.

Table 2. Root-Mean-Square Comparisons for Perforated Barrel Extensions.

Ammo Type	brake			holes			slots		
	σ_x	σ_y	σ_r	σ_x	σ_y	σ_r	σ_x	σ_y	σ_r
M793	0.85	0.67	1.08	0.64	0.69	0.93	0.80	0.41	0.90
M910	0.54	0.46	0.71	0.43	0.44	0.62	0.49	0.44	0.66

These results show that both perforated barrel extensions performed at least as well as the barrel-brake combination. The M793 lot for this test did not perform nearly as well as the lot used in the test with the unperforated tubes. For both ammunition types, the extensions generated dispersion values that were similar to those for the standard brake. Furthermore, perforating the tubes did not degrade the dispersion pattern for either ammunition type.

Next, the tubes were machined down to the shape to be used with the muffler shell. Figure 2 depicts the final machined barrel extension for the slotted configuration.

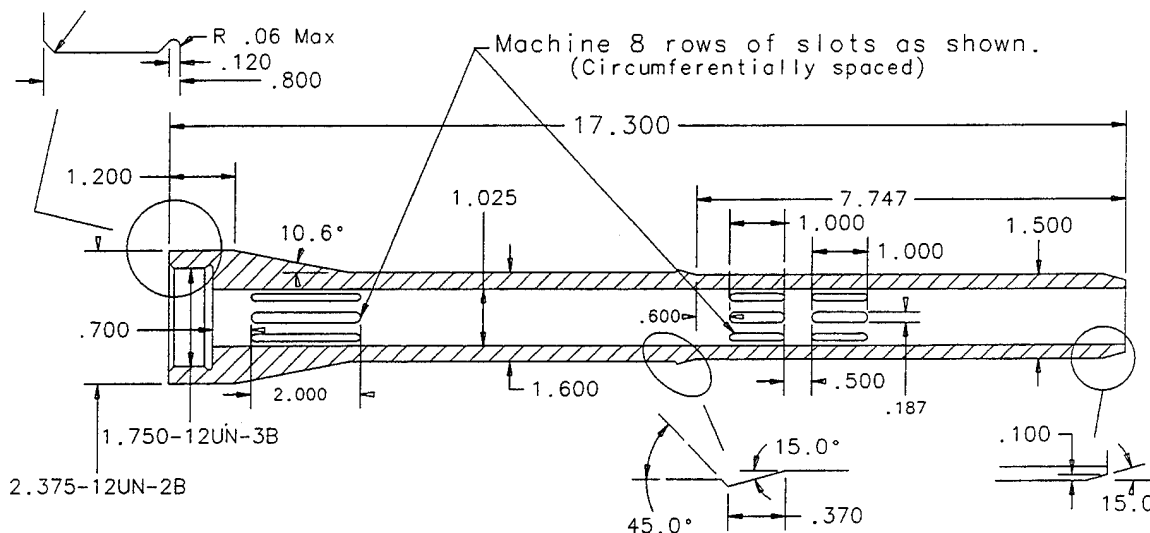

Figure 2. Slotted Barrel Extension (Dimensions in Inches).

The slots are placed near the beginning of each chamber since experiment showed (Fansler

and Lyon 1989) that this placement gave the most sound attenuation. Slots allow more mass out-flow than for holes with the same total perforated area and with the same width. However, high material stress values occur at the front and rear boundaries of slots when the tubes are subjected to high internal gas pressure. Thus, the durability of the muffler system may be reduced, and further testing is needed.

Figure 3 shows the extension with the holes. The use of holes instead of slots results in a reduction of material stress near the hole boundary. Again, the holes were placed near the beginning of the chamber, but the number of holes needed imposes a long span of the extension being taken up with holes. There are two possible drawbacks to the use of holes instead of longer slots. More of the gas will go through a shock created by the interaction of the propellant gas with the edge of the hole. Shocks reduce the stagnation pressure and increase the temperature of the propellant in the muffler shell. Reduction of the stagnation pressure results in a less effective muffler and an increased likelihood of flash. More gas will be flowing out further forward in each chamber, thus reducing the noise attenuation values according to the Fansler and Lyon (1989) study.

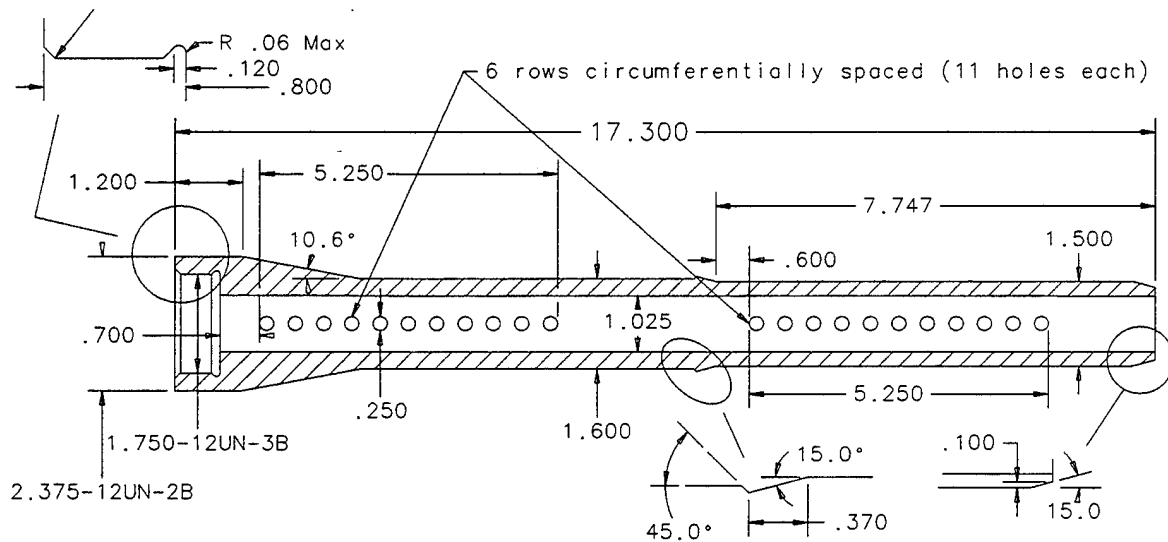

Figure 3. Holed Barrel Extension (Dimensions in Inches).

3. MUFFLER DESIGN AND TESTING

The muffler shell is similar to a prior muffler shell developed by Fansler et al. (1992) and is shown in Figure 4 mounted on the barrel extension tube. The muffler's design was

guided primarily by the experience obtained with the general purpose muffler (Fansler et al. 1992) that was adapted to the special barrel. The volume of the muffler shell was made comparable to the volume of the earlier general purpose muffler and the perforated area of the muzzle extension is comparable to the perforated area for the special barrel. This muffler shell with barrel extension weighs approximately 8.64 kg (19 lb), whereas the extension tube, before it was turned down, weighed approximately 8.18 kg (18 lb). The muffler screws onto threads located near the muzzle on the muzzle extension. As the muffler shell is screwed on, its baffle-hole boundaries are forced against the cone sections of the extension tube, thus providing a seal for each chamber. This fastening method does not require the use of any other locking device. Sufficient venting area in the muzzle extension allows the flow to exit into the chambers of the muffler and minimize the peak energy efflux from the muzzle extension exit, thus reducing the noise levels (Fansler and Schmidt 1982; Fansler et al. 1993).

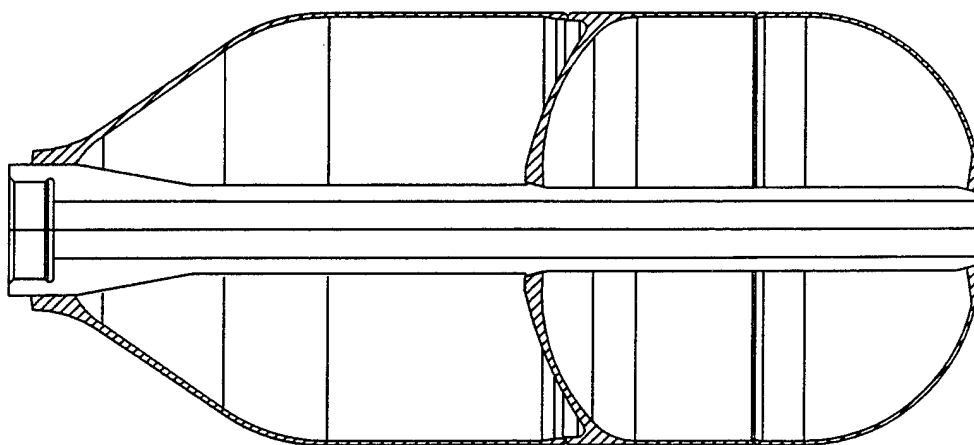

Figure 4. Muffler Shell with Extension Tube (Vents not Shown).

When the muffler shell was assembled, the slotted barrel extension was used to hold the shell components in position to be welded. The welded area contracted when cooled, putting the shell in longitudinal tension against the slotted barrel extension. Subsequent attempts to remove the shell from the barrel extension were unsuccessful. The shell and extension tube were placed in an oven and precipitation hardened by heating to 1,000 °F for 2 hr. Further development and testing were performed only with the slotted extension and the muffler shell.

3.1 Dispersion Testing. The dispersion testing for the muffler and the brake was conducted under the same conditions as for the extension tube. Table 3 gives the results.

Table 3. Root-Mean-Square Comparison between Muffler and Standard Brake.

Ammo Type	Brake			Muffler		
	σ_x	σ_y	σ_r	σ_x	σ_y	σ_r
M793	0.38	0.35	0.52	0.53	0.72	0.89
M910	0.39	0.29	0.49	0.40	0.53	0.66

Unlike earlier experiments, the slotted barrel with the muffler shell show larger dispersion values than for the barrel with a brake. Perhaps, the extension tube may be shifting on its threads when the muffler system is subjected to heavy axial loads from the flow impinging onto the muffler's baffles. After the results were obtained, it was recalled that the muffler that screwed onto a regular barrel also yielded poor dispersion patterns until the muffler was further tightened (Fansler et al. 1992). The present muffler system was not held on the barrel as tightly as other mufflers that have been used with the standard barrel. To minimize dispersion, it is important for the muffler to behave as an integral part of the barrel with no relative movement between them.

3.2 Noise Attenuation Test and Results. The test was performed by the noise measurement group in the U.S. Army Combat Systems Test Activity (CSTA). Tests of prior mufflers have been performed at 75 m to the sides and rear, but test conditions at CSTA's range did not allow such distances. Microphones were placed both 2 and 10 m to the side of the gun muzzle and 46 cm to the left of the breech. The same barrel and brake as for the prior tests were used. The resultant attenuation (dB-Peak) is shown in Table 4. The noise was measured using both M793 and M910 rounds, and these results are shown in separate columns.

Table 4. Noise Attenuation Referenced with Brake – dB-Peak.

Position	M793	M910
Side (2 m)	10.8	9.3
Side (10 m)	7.8	6.6
46 cm left of breech	17.8	16.3

These values at 2 m to the side can be compared with a test performed for the muffler designed to be used with the special perforated barrel firing M793 rounds. Although these

tests were performed in 1989, they have not been reported until now. These tests were performed with microphones located 2.3 and 7.5 m to the side of the muzzle. The old standard barrel/brake values were used to compare with the values obtained with the present muffler. The new brake does not need to be as effective as the old brake since the new barrel is heavier and will not recoil as far as the old barrel. Thus, the new brake will not divert as much propellant gas to the rear, as compared to the old brake, and the noise levels produced to the rear should be lower. The noise levels to the side may also be lower for the new brake. Therefore, a direct comparison of the new results with the old experiment does not yield a clear idea of the attenuation of the new muffler with respect to the old brake, which is the standard of comparison. The attenuations at locations 2.3 and 7.5 m to the side of the muzzle were respectively 17 and 12 dB-Peak. These values are large enough that one might conclude that the muffler with the perforated barrel (Fansler et al. 1992) was more effective. Nevertheless, the next generation of the present muffler could easily copy the essential features that differentiate the old muffler from the new muffler. For instance, the perforated area of the modified barrel that allows gas to enter the first muffler chamber was larger than the respective area for the new muffler. The perforated area for the extension could easily be doubled. Also, the front of the old muffler forms a cone, thus lowering the exit pressure of the propellant gas. According to recent gun blast experiments (Fansler et al. 1993), the lower pressure but higher speed exit gas should result in the blast wave strength being concentrated more in the forward direction and lowered to the sides and rear. This feature could also be designed in the next generation muffler.

4. TESTS AT GRAFENWOEHR TRAINING AREA, GERMANY

After designing, fabricating, and testing of the muffler at Aberdeen Proving Ground, MD, the AMC-FAST office arranged for a demonstration at the GTA, Germany. Before testing at the GTA, the muffler was modified in an attempt to keep the muffler from loosening on the barrel threads. Two setscrews were inserted into the collar of the muffler so that one of the screws fit tightly in the groove of the old-style barrel.

Two BFVs were placed on tracks 14 m apart and parallel to each other. The left BFV (from the rear) used the old standard 40.5-kg (89 lb) barrel with its standard brake, which vents from the sides. The other BFV was equipped with the present muffler attached to the standard barrel. A noise meter was set up to record the noise in slow A impulse mode, which is commonly used in Germany. One BFV would fire 10 shots spaced 10 s apart, and then the other BFV would follow suit. Noise readings were taken 110 m to the rear of the

vehicle and also 160 m to the rear. The muffler reduced the noise by approximately 21 dB and 27 dB at the respective positions of 110 and 160 m behind the BFVs.

The noise measurements to the rear showed that the muffler provided a more than adequate noise reduction. The noise reduction improved with distance and is due partly to greater absorption rates of higher frequency noise for the air and ground. The muffler displaces the noise energy to higher frequencies.

The gunner for the Bradley with the muffler thought that the accuracy and dispersion was comparable to a BFV equipped with the standard barrel/brake system. The slewing and sighting performances were not adversely affected. But when the muffler was removed from the barrel, it was found that the muffler had come loose on the threads. The setscrew appeared to be sheared off, allowing the muffler to loosen. Clearly, further work needs to be done to retain the muffler tightly on the barrel.

5. SUMMARY AND CONCLUSIONS

A prototype muffler that fits on the standard barrel of the 25-mm M242 chain gun and is capable of firing all types of training ammunition has been designed, fabricated, and performance tested. Experience with other mufflers and the current muffler show that the noise reduction requirements can be met and exceeded with this basic design. Other requirements concerning reliability, durability, and ease of use have not been completely tested and verified. But mufflers of similar design (Fansler et al. 1992) have been fired repeatedly under worst-case training scenarios. Further development and testing is being transitioned to ARDEC.

The tested dispersion values were greater than for the standard brake, but dispersion values for the muffler should improve when it is attached tightly to the barrel. Other mufflers designed for the 25-mm chain gun have resulted in dispersion values approximately equal to the gun equipped with the standard brake.

INTENTIONALLY LEFT BLANK.

6. REFERENCES

- Committee for the Application of Measurement Techniques. "VDI-Guideline Society of German Engineers Assessment of Working Noise in the Vicinity VDI 2058, No. 1." English translation, U. S. Army Foreign Science and Technology Center, Charlottesville, VA, FSTC-HT-208-87, June 1987.
- Fansler, K. S., and E. M. Schmidt. "The Relationship Between Interior Ballistics, Gun Exhaust Parameters and the Muzzle Blast Overpressure." AIAA Paper 82-0856, *Proceedings of the AIAA/ASME 3rd Joint Thermophysics, Fluids, Plasma and Heat Transfer Conference*, St. Louis, MO, 7-11 June 1982.
- Fansler, K. S., and D. H. Lyon. "Attenuation of Muzzle Blast Using Configurable Muffler." ARBRL-TR-2979, U.S. Army Ballistic Research Laboratory, Aberdeen Proving Ground, MD, January 1989 (AD A206565).
- Fansler, K. S., R. Von Wahlde, SSG D. Kelham, and T. T. Vong. "A General Purpose Prototype Muffler for the Bradley Fighting Vehicle 25-mm Automatic Cannon." ARL-TR-4, U.S. Army Research Laboratory, Aberdeen Proving Ground, MD, November 1992.
- Fansler, K. S., W. P. Thompson, J. S. Carnahan, and B. J. Patton. "A Parametric Investigation of Muzzle Blast." ARL-TR-227, U.S. Army Research Laboratory, Aberdeen Proving Ground, MD, September 1993.
- Lewis, H. N. "Research Test, Noise Suppressor Study for Gun, Automatic, 25-MM, M242." TECOM Project No. 1-WE-100-BUS-004, Firing Record No. S-51048, U. S. Army Combat Systems Test Activity, Aberdeen Proving Ground, MD, March 1988.
- Steier, G. M. "Research Test, Sabot Capable Noise Suppressor Study for M242, 25-mm Gun." TECOM Project No. 1-WE-100-BUS-048, Test Record No. S-51186, U. S. Army Combat Systems Test Activity, Aberdeen Proving Ground, MD, March 1994.

INTENTIONALLY LEFT BLANK.

APPENDIX:
DETAILED TARGET DISPERSION VALUES

INTENTIONALLY LEFT BLANK.

These tests were designed to obtain dispersion data in a simple way and screen out the candidate barrel extensions that are the poorer performers. Firing from a mount also reduces costs and reduces the number of test variables. Any extensive development effort would require tests performed with a BFV under training conditions.

The numbers in Table 5 refer to the expected standard deviation (SD) for each target and combination of ammunition type and muzzle device. As mentioned earlier, 10 rounds were fired single shot under the conditions shown in Table 5. Ten shots were fired at each target. Although the barrel was allowed to cool down when the barrel device was changed, the barrel would become increasingly hotter when the next target was selected. Other details are in the body of the report.

Table 5. Dispersion Comparisons (mils) for Unperforated Barrel Extensions.

Ammo Type	Brake			Straight			Squeeze		
	σ_x	σ_y	σ_r	σ_x	σ_y	σ_r	σ_x	σ_y	σ_r
M793	0.30	0.28	0.41	0.23	0.21	0.31	0.29	0.32	0.43
	0.25	0.23	0.34	0.48	0.43	0.64	0.42	0.44	0.61
	0.25	0.36	0.43	0.32	0.27	0.41	0.53	0.50	0.72
	0.36	0.35	0.50	0.41	0.50	0.65	0.39	0.41	0.56
	0.19	0.39	0.43	0.27	0.35	0.44	0.35	0.47	0.59
M910	0.35	0.41	0.54	0.38	0.46	0.59	0.33	0.25	0.42
	0.56	0.44	0.71	0.43	0.35	0.55	0.30	0.16	0.34
	0.27	0.41	0.49	0.41	0.24	0.47	0.29	0.20	0.35
	0.65	0.32	0.75	0.44	0.30	0.53	0.25	0.35	0.43
	0.34	0.40	0.52				0.38	0.28	0.47

The barrel was allowed to cool down when changing from one type of ammunition to the other, and also when changing from one device to another. There was no growth or reduction in dispersion as the firing progressed.

The dispersion results for the perforated muzzle extensions are shown in Table 6. With the change in the lot number, the dispersion for the M793 ammunition increased significantly, from performing better than the M910 ammunition to performing much worse than the M910 ammunition. When the same lot of sabot M910 ammunition was shot, the perforated devices showed somewhat larger dispersions than when the devices were unperforated. But the dispersion values for the brake with the M910 ammunition are also somewhat larger than for the tests performed for Table 5. Thus, it cannot be concluded that perforating the devices caused the dispersion to increase. Increased wear cannot be attributed to the dispersion increase since no large tests were conducted with the barrel between our tests.

Dispersion tests for the muffler were performed as before. The results are shown in Table 7. The muffler did not perform as well. However, as discussed in the body, the muffler loosened on the threads and probably contributed significantly to the increased dispersion values.

Table 6. Dispersion Results (mils) for Perforated Barrel Extensions.

Ammo Type	Brake			Holes			Slots		
	σ_x	σ_y	σ_r	σ_x	σ_y	σ_r	σ_x	σ_y	σ_r
M793	0.62	0.48	0.78	0.46	0.51	0.69	0.76	0.53	0.93
	0.67	1.01	1.21	0.65	0.62	0.89	1.35	0.34	1.39
	1.42	0.72	1.59	0.73	1.04	1.27	0.44	0.47	0.65
	0.61	0.45	0.76	0.65	0.59	0.88	0.51	0.29	0.59
	0.61	0.49	0.78	0.66	0.53	0.84	0.61	0.37	0.71
M910	0.74	0.40	0.84	0.48	0.59	0.75	0.40	0.54	0.67
	0.49	0.39	0.63	0.34	0.42	0.54	0.45	0.48	0.65
	0.52	0.51	0.73	0.36	0.26	0.44	0.53	0.28	0.60
	0.27	0.26	0.38	0.52	0.41	0.66	0.38	0.44	0.58
	0.55	0.65	0.85	0.44	0.47	0.64	0.65	0.41	0.76

Table 7. Dispersion Results (mils) for Muffler with Slotted Barrel Extension.

Ammo Type	Brake			Muffler		
	σ_x	σ_y	σ_r	σ_x	σ_y	σ_r
M793	0.42	0.28	0.50	0.54	0.64	0.84
	0.34	0.38	0.51	0.57	0.79	0.97
	0.46	0.33	0.57	0.41	0.76	0.86
	0.26	0.40	0.48	0.59	0.81	1.00
	0.41	0.37	0.55	0.53	0.60	0.80
M910	0.53	0.26	0.59	0.44	0.52	0.68
	0.25	0.16	0.30	0.34	0.66	0.74
	0.37	0.32	0.49	0.43	0.36	0.56
	0.26	0.23	0.35	0.44	0.56	0.71
	0.46	0.43	0.63	0.31	0.50	0.59

NO. OF
COPIES ORGANIZATION

2 ADMINISTRATOR
ATTN DTIC DDA
DEFENSE TECHNICAL INFO CTR
CAMERON STATION
ALEXANDRIA VA 22304-6145

1 DIRECTOR
ATTN AMSRL OP SD TA
US ARMY RESEARCH LAB
2800 POWDER MILL RD
ADELPHI MD 20783-1145

3 DIRECTOR
ATTN AMSRL OP SD TL
US ARMY RESEARCH LAB
2800 POWDER MILL RD
ADELPHI MD 20783-1145

1 DIRECTOR
ATTN AMSRL OP SD TP
US ARMY RESEARCH LAB
2800 POWDER MILL RD
ADELPHI MD 20783-1145

ABERDEEN PROVING GROUND

5 DIR USARL
ATTN AMSRL OP AP L (305)

<u>NO. OF COPIES</u>	<u>ORGANIZATION</u>
1	COMMANDER ATTN AMSMC LEP L USA ARMAMENT MUNITIONS & CHEM CMD ROCK ISLAND IL 61299-5000
1	DIRECTOR ATTN AIAMS YDL USA MIS & SPACE INTLLGNC CTR REDSTONE ARSNL AL 35898-5000
3	COMMANDER ATTN SMCWV QAR T MCCLOSKEY SMCWV ODW T FITZPATRICK SMCWV ODP G YARTER US ARMY WATERVLIET ARSNL WATERVLIET NY 12189
1	COMMANDER ATTN AMSTA AR TD MR HIRSHMAN US ARMY ARMAMENT RD&E CTR PCNTY ARSNL NJ 07801-5000
4	COMMANDER ATTN AMSTA AR AET A S KAHN M AMORUSO PEDERSEN C NG W TOLEDO B WONG US ARMY ARMAMENT RD&E CTR PCNTY ARSNL NJ 07801-5000
1	COMMANDER ATTN AMSTA AR CCL D S LISS US ARMY ARMAMENT RD&E CTR PCNTY ARSNL NJ 07801-5000
2	COMMANDER ATTN AMCPM BFVS AMCPM BFVS SC K PITCO US ARMY TANK AUTOMOTIVE CMD WARREN MI 48397-5000
1	COMMANDER ATTN AMSMI RD W WALKER US ARMY MISSILE COMMAND REDSTONE ARSNL AL 35898-5000

<u>NO. OF COPIES</u>	<u>ORGANIZATION</u>
1	COMMANDER ATTN AMCPM TMA R BILLINGTON TANK MAIN ARMAMENT SYSTEMS PCNTY ARSNL NJ 07806-5000
2	COMMANDANT ATTN ATSH IV SD R GORDAY ATSH TSM US ARMY INFANTRY SCHOOL FORT BENNING GA 31905-5660
5	DIRECTOR ATTN SMCAR CCB J BENDICK T SIMKINS SMCAR CCB DS P VOTTIS SMCAR CCB RA G CAROFANO SMCAR CCB RA BENET LABORATORIES WATERVLIET NY 12189-4050
1	COMMANDER ATTN AMXRO MCS K CLARK ARMY RESEARCH OFFICE PO BOX 12211 RSRCH TRI PK NC 27709-2211
1	COMMANDER ATTN AMXRO RT IP LIBRARY SVCS ARMY RESEARCH OFFICE PO BOX 12211 RSRCH TRI PK NC 27709-2211
1	COMMANDER ATTN SAVRT TY MSMA G MOFFATT AVIATION APPLIED TECHNICAL DIR FORT EUSTIS VA 23604-5577
3	DEPARTMENT OF THE ARMY ATTN CERL SOI P SCHOMER L PATER J WILCOSKI CONSTRUCTION ENGRG RSRCH LAB PO BOX 4000 CHAMPAIGN IL 61820

<u>NO. OF COPIES</u>	<u>ORGANIZATION</u>	<u>NO. OF COPIES</u>	<u>ORGANIZATION</u>
2	COMMANDER ATTN WL MNAA CPT J PALUMBO ASD YHT D CURLEY ASD YHT EGLIN AFB FL 32542	1	S & D DYNAMICS INC ATTN R BECKER 7208 MONTRICO DR BOCA RATON FL 33433-6930
1	COMMANDER CODE 3433 ATTN TECH LIB NAVAL WARFARE CENTER CHINA LAKE CA 93555	1	AAI CORPORATION ATTN T STASNEY PO BOX 126 MS 100 405 HUNT VALLEY MD 21030-0126
2	COMMANDER ATTN 6X J YAGLA G MOORE NAVAL SURFACE WARFARE CENTER DAHLGREN VA 22448	2	AEROJET GENERAL CORPORATION ATTN W WOLTERMAN A FLATAU PO BOX 296 AZUSA CA 91702
1	COMMANDER CODE 6120C ATTN SUSAN PETERS NAVAL ORDNANCE STATION INDIAN HEAD MD 20640	2	LOCKHEED AIRCRAFT INC ATTN J BROWN J PEREZ PO BOX 33 DEPT 1 330 UPLAND ONTARIO CA 91761
1	COMMANDER CODE 3892 ATTN K SCHADOW NAVAL WARFARE CENTER CHINA LAKE CA 93555	1	GEN ELECTR ARMAMENT & ELECTR SYS ATTN R WHYTE LAKESIDE AVE BURLINGTON VT 05401
1	COMMANDER CODE 730 NAVAL SURFACE WARFARE CENTER SILVER SPRING MD 20910	1	FRANKLIN INSTITUTE ATTN TECH LIBRARY RACE & 20TH STREETS PHILADELPHIA PA 19103
1	DIRECTOR ATTN SAK DL NASA SCIENTIFIC & TECHL INFO FACLTY PO BOX 8757 BWI AIRPORT MD 21240	1	THE JOHNS HOPKINS UNIV/CPIA 10630 LITTLE PATUXENT PKY SUITE 202 COLUMBIA MD 21044-3200
1	MCDONNELL DOUGLAS ATTN JOSEPH SMUCKLER 1014 FERNGATE LANE CREVE COEUR MO 63141	2	LORAL CORPORATION ATTN S SCHMOTOLOCHA B AXELY 300 N HALSTEAD STR PO BOX 7101 PASADENA CA 91109
2	ALLIANT TECHSYSTEMS INC ATTN MS MN 50 2060 T MELANGER S LANGLEY 600 SECOND STR NORTHEAST HOPKINS MN 55343	2	MCDONNELL DOUGLAS HELICOPTER CO ATTN D VAN OSTEEEN R WATERFIELD MAIL STATION D216 500 E MCDOWELL RD MESA AZ 85205

<u>NO. OF COPIES</u>	<u>ORGANIZATION</u>	<u>NO. OF COPIES</u>	<u>ORGANIZATION</u>
1	FN MANUFACTURING INC ATTN GEORGE KONTIS PO BOX 24257 COLUMBIA SC 29224	2	UNIVERSITY OF VIRGINIA ATTN H G WOOD III J MORTON DEPT OF MECHANICAL & AEROSPACE ENGRG CHARLOTTESVILLE VA 22901
2	ARROW TECH ASSOCIATES INC ATTN ROBERT WHYTE WAYNE HATHAWAY 1233 SHELBURNE RD SUITE D8 SOUTH BURLINGTON VT 05403		<u>ABERDEEN PROVING GROUND</u>
1	GA INSTITUTE OF TECHLGY ATTN G P NEITZEL THE GEORGE W WOODRUFF SCHOOL OF MECHANICAL ENGINEERING ATLANTA GA 30332	2	DIR USAMSAA ATTN AMXSY D W BROOKS R CONROY
1	UNITED DEFENSE LP ATTN SUZANNE DAVISON ARMAMENT SYSTEMS DIVISION 4800 E RIVER RD MAIL STOP M239 MINNEAPOLIS MN 55421	5	CDR USACSTA ATTN STECS AAL M MAULE STECS AS LA S WALTON STECS DA P PAULES STECS RM PF S HINTE STECS AS HP J ANDREWS
1	OLD DOMINION UNIVERSITY MATHEMATICS DEPT ATTN CHARLIE COOKE NORFOLK VA 23508	2	CDR USATECOM ATTN AMSTE TE R MR KEELE AMSTE TA R W MARSHALL
1	SCITEC INC ATTN ALEX ZISLAN 100 WALL STREET PRINCETON NJ 08540	1	DIR AMC ATTN AMCICP IM R BLOOM INT MAT EVAL DIV
1	LOS ALAMOS NATIONAL LAB ATTN THOMAS DAVIS GROUP WX 4 MS G787 LOS ALAMOS NM 87545	2	DIR USARL ATTN AMSRL HR SD G GARINTHER J KALB
1	OLIN CORPORATION ATTN STEPHAN FAINTICH PO BOX 222 ST MARKS FL 32355	4	DIR USAARDEC ATTN SMCAR FSF T R LIESKE J MATTS R PUHALLA J WHITESIDE
1	ATLANTIC RESEARCH CORP ATTN MARK FRIEDLANDER 5945 WELLINGTON RD MS G787 GAINESVILLE VA 22065	30	DIR USARL ATTN AMSRL WT INGO MAY DOUGLAS S SAVICK AMSRL WT P ALBERT A HORST AMSRL WT PA THOMAS C MINOR GEORGE E KELLER MICHAEL NUSCA

NO. OF
COPIES ORGANIZATION

ABERDEEN PROVING GROUND (CONT)

AMSRL WT PB
EDWARD M SCHMIDT
DAVID W WEBB
PETER PLOSTINS
GENE R COOPER
MARK L BUNDY
DAVID H LYON
BRENDAN J PATTON
KEITH P SOENCKSEN
VURAL OSKAY
JAMES M GARNER
PAUL N WEINACHT
BERNARD J GUIDOS
HARRIS L EDGE
JUBARAJ SAHU
AMEER G MIKHAIL
ALEXANDER E ZIELINSKI
AMSRL WT PC ROBERT A FIFER
AMSRL WT PD BRUCE P BURNS
AMSRL WT W C H MURPHY
AMSRL WT WB
W D'AMICO
BRADFORD S DAVIS
AMSRL WT WC
J A BORNSTEIN
R VON WAHLDE
AMSRL OP WT IS G I BROWN

INTENTIONALLY LEFT BLANK.

USER EVALUATION SHEET/CHANGE OF ADDRESS

This Laboratory undertakes a continuing effort to improve the quality of the reports it publishes. Your comments/answers to the items/questions below will aid us in our efforts.

1. ARL Report Number ARL-MR-243 Date of Report July 1995
2. Date Report Received _____
3. Does this report satisfy a need? (Comment on purpose, related project, or other area of interest for which the report will be used.) _____

4. Specifically, how is the report being used? (Information source, design data, procedure, source of ideas, etc.) _____

5. Has the information in this report led to any quantitative savings as far as man-hours or dollars saved, operating costs avoided, or efficiencies achieved, etc? If so, please elaborate. _____

6. General Comments. What do you think should be changed to improve future reports? (Indicate changes to organization, technical content, format, etc.) _____

CURRENT ADDRESS	_____
	Organization

	Name

Street or P.O. Box No.	

City, State, Zip Code	

7. If indicating a Change of Address or Address Correction, please provide the Current or Correct address above and the Old or Incorrect address below.

OLD ADDRESS	_____
	Organization

	Name

Street or P.O. Box No.	

City, State, Zip Code	

(Remove this sheet, fold as indicated, tape closed, and mail.)
(DO NOT STAPLE)

DEPARTMENT OF THE ARMY

OFFICIAL BUSINESS

BUSINESS REPLY MAIL
FIRST CLASS PERMIT NO 0001,APG,MD

POSTAGE WILL BE PAID BY ADDRESSEE

**DIRECTOR
U.S. ARMY RESEARCH LABORATORY
ATTN: AMSRL-WT-PB
ABERDEEN PROVING GROUND, MD 21005-5066**

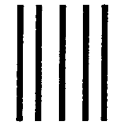

**NO POSTAGE
NECESSARY
IF MAILED
IN THE
UNITED STATES**

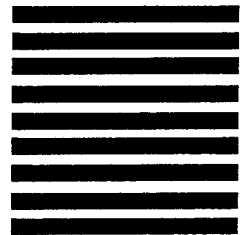

7
8