

STATIA No. 173948
STATIA FILE COPY

NATIONAL ADVISORY COMMITTEE FOR AERONAUTICS

REPORT No. 578

FLIGHT MEASUREMENTS OF THE DYNAMIC LONGITUDINAL STABILITY OF SEVERAL AIRPLANES AND A CORRELATION OF THE MEASUREMENTS WITH PILOTS' OBSERVATIONS OF HANDLING CHARACTERISTICS

By HARTLEY A. SOULE



DISTRIBUTION STATEMENT A
Approved for public release
Distribution Unlimited

1936

DTIC QUALITY INSPECTED 6

19950828 132

PROPELLER LABORATORY

AERONAUTIC SYMBOLS

1. FUNDAMENTAL AND DERIVED UNITS

	Symbol	Metric		English	
		Unit	Abbreviation	Unit	Abbreviation
Length.....	l	meter.....	m	foot (or mile).....	ft. (or mi.)
Time.....	t	second.....	s	second (or hour).....	sec. (or hr.)
Force.....	F	weight of 1 kilogram.....	kg	weight of 1 pound.....	lb.
Power.....	P	horsepower (metric).....		horsepower.....	hp.
Speed.....	V	kilometers per hour.....	k.p.h.	miles per hour.....	m.p.h.
		meters per second.....	m.p.s.	feet per second.....	f.p.s.

2. GENERAL SYMBOLS

<p>W, Weight = mg</p> <p>g, Standard acceleration of gravity = 9.80665 m/s² or 32.1740 ft./sec.²</p> <p>m, Mass = $\frac{W}{g}$</p> <p>I, Moment of inertia = mk^2. (Indicate axis of radius of gyration k by proper subscript.)</p> <p>μ, Coefficient of viscosity</p>	<p>ν, Kinematic viscosity</p> <p>ρ, Density (mass per unit volume) Standard density of dry air, 0.12497 kg-m⁻³ at 15° C. and 760 mm; or 0.002378 lb.-ft.⁻³ sec.² Specific weight of "standard" air, 1.2255 kg/m³ or 0.07351 lb./cu.ft.</p>
--	---

3. AERODYNAMIC SYMBOLS

<p>S, Area</p> <p>S_w, Area of wing</p> <p>G, Gap</p> <p>b, Span</p> <p>c, Chord</p> <p>$\frac{b^2}{S}$, Aspect ratio</p> <p>V, True air speed</p> <p>q, Dynamic pressure = $\frac{1}{2}\rho V^2$</p> <p>L, Lift, absolute coefficient $C_L = \frac{L}{qS}$</p> <p>D, Drag, absolute coefficient $C_D = \frac{D}{qS}$</p> <p>D_o, Profile drag, absolute coefficient $C_{D_o} = \frac{D_o}{qS}$</p> <p>D_i, Induced drag, absolute coefficient $C_{D_i} = \frac{D_i}{qS}$</p> <p>D_p, Parasite drag, absolute coefficient $C_{D_p} = \frac{D_p}{qS}$</p> <p>C, Cross-wind force, absolute coefficient $C_C = \frac{C}{qS}$</p> <p>R, Resultant force</p>	<p>i_w, Angle of setting of wings (relative to thrust line)</p> <p>i_s, Angle of stabilizer setting (relative to thrust line)</p> <p>Q, Resultant moment</p> <p>Ω, Resultant angular velocity</p> <p>$\rho \frac{Vl}{\mu}$, Reynolds Number, where l is a linear dimension (e.g., for a model airfoil 3 in. chord, 100 m.p.h. normal pressure at 15° C., the corresponding number is 234,000; or for a model of 10 cm chord, 40 m.p.s. the corresponding number is 274,000)</p> <p>C_p, Center-of-pressure coefficient (ratio of distance of $c.p.$ from leading edge to chord length)</p> <p>α, Angle of attack</p> <p>ϵ, Angle of downwash</p> <p>α_o, Angle of attack, infinite aspect ratio</p> <p>α_i, Angle of attack, induced</p> <p>α_a, Angle of attack, absolute (measured from zero-lift position)</p> <p>γ, Flight-path angle</p>
--	--

REPORT No. 578

**FLIGHT MEASUREMENTS OF THE DYNAMIC
LONGITUDINAL STABILITY OF SEVERAL AIRPLANES
AND A CORRELATION OF THE MEASUREMENTS
WITH PILOTS' OBSERVATIONS OF
HANDLING CHARACTERISTICS**

By **HARTLEY A. SOULÉ**
Langley Memorial Aeronautical Laboratory

100052-36

I

Accession For		
NTIS CRA&I	<input checked="" type="checkbox"/>	
DTIC TAB	<input type="checkbox"/>	
Unannounced	<input type="checkbox"/>	
Justification		
By		
Distribution /		
Availability Codes		
Dist	Avail and/or Special	
A-1		

NATIONAL ADVISORY COMMITTEE FOR AERONAUTICS

HEADQUARTERS, NAVY BUILDING, WASHINGTON, D. C.

LABORATORIES, LANGLEY FIELD, VA.

Created by act of Congress approved March 3, 1915, for the supervision and direction of the scientific study of the problems of flight (U. S. Code, Title 50, Sec. 151). Its membership was increased to 15 by act approved March 2, 1929. The members are appointed by the President, and serve as such without compensation.

JOSEPH S. AMES, Ph. D., *Chairman*,
Baltimore, Md.

DAVID W. TAYLOR, D. Eng., *Vice Chairman*,
Washington, D. C.

CHARLES G. ABBOT, Sc. D.,
Secretary, Smithsonian Institution.

LYMAN J. BRIGGS, Ph. D.,
Director, National Bureau of Standards.

ARTHUR B. COOK, Rear Admiral, United States Navy,
Chief, Bureau of Aeronautics, Navy Department.

WILLIS RAY GREGG, B. A.,
Chief, United States Weather Bureau.

HARRY F. GUGGENHEIM, M. A.,
Port Washington, Long Island, N. Y.

SYDNEY M. KRAUS, Captain, United States Navy,
Bureau of Aeronautics, Navy Department.

CHARLES A. LINDBERGH, LL. D.,
New York City.

WILLIAM P. MACCRACKEN, JR., LL. D.,
Washington, D. C.

AUGUSTINE W. ROBINS, Brigadier General, United States Army,
Chief Matériel Division, Air Corps, Wright Field, Dayton,
Ohio.

EUGENE L. VIDAL, C. E.,
Director of Air Commerce, Department of Commerce.

EDWARD P. WARNER, M. S.,
New York City.

OSCAR WESTOVER, Major General, United States Army,
Chief of Air Corps, War Department.

ORVILLE WRIGHT, Sc. D.,
Dayton, Ohio.

GEORGE W. LEWIS, *Director of Aeronautical Research*

JOHN F. VICTORY, *Secretary*

HENRY J. E. REID, *Engineer in Charge, Langley Memorial Aeronautical Laboratory, Langley Field, Va.*

JOHN J. IDE, *Technical Assistant in Europe, Paris, France*

TECHNICAL COMMITTEES

AERODYNAMICS

POWER PLANTS FOR AIRCRAFT

AIRCRAFT STRUCTURES AND MATERIALS

AIRCRAFT ACCIDENTS

INVENTIONS AND DESIGNS

Coordination of Research Needs of Military and Civil Aviation

Preparation of Research Programs

Allocation of Problems

Prevention of Duplication

Consideration of Inventions

LANGLEY MEMORIAL AERONAUTICAL LABORATORY

LANGLEY FIELD, VA.

Unified conduct, for all agencies, of scientific research on the fundamental problems of flight.

OFFICE OF AERONAUTICAL INTELLIGENCE

WASHINGTON, D. C.

Collection, classification, compilation, and dissemination of scientific and technical information on aeronautics.

REPORT No. 578

FLIGHT MEASUREMENTS OF THE DYNAMIC LONGITUDINAL STABILITY OF SEVERAL AIRPLANES AND A CORRELATION OF THE MEASUREMENTS WITH PILOTS' OBSERVATIONS OF HANDLING CHARACTERISTICS

By HARTLEY A. SOULÉ

SUMMARY

The dynamic longitudinal stability characteristics of eight airplanes as defined by the period and damping of the longitudinal oscillations were measured in flight to determine the degree of stability that may be expected in conventional airplanes. An attempt was made to correlate the measured stability with pilots' opinions of the general handling characteristics of the airplanes in order to obtain an indication of the most desirable degree of dynamic stability. The results of the measurements show that the period of oscillation increases with speed. At low speeds a range of periods from 11 to 23 seconds was recorded for the different airplanes. At high speeds the periods ranged from 23 to 64 seconds. The damping showed no definite trend with speed. A general tendency for airplanes that were stable with power off to become unstable with power on was noted. The maximum damping recorded was sufficient to reduce the amplitude of oscillation by one-half in 9 seconds, or approximately one-fourth cycle. The opinions of two pilots concerning the handling characteristics of the airplanes apparently were not influenced by the stability characteristics as defined by the period and damping of the longitudinal oscillations.

INTRODUCTION

The theory of dynamic longitudinal stability of airplanes, although not complete for power-on flight owing to a lack of knowledge of the effect of the propeller slipstream on certain of the stability derivatives, has been developed to the point where it is possible to predict the power-off stability characteristics of an airplane from its dimensions. (See reference 1.) The longitudinal motion of an airplane following a disturbance may consist either of a continuous divergence, i. e., static instability, or of two superimposed oscillations of different periods and damping. In the present case consideration is given only to the oscillatory motion since no statically unstable airplane should be regarded as satisfactory. The periods and damping of both

oscillations are given by the theory but, as the short-period oscillation is so heavily damped that there is no probability of instability of the oscillation for conventional airplanes, it is usual to consider the dynamic longitudinal stability characteristics to be defined by the period and damping of only the long-period, or phugoid, oscillation. With the aid of the charts of reference 1, the areas and dimensions of airplanes can be adjusted during design to produce, within limits, any length of the period and magnitude of damping desired for this oscillation. Aside from the desirability of having the airplane stable for all normal-flight conditions, little is known as to the length of the period and the magnitude of the damping that constitute satisfactory stability. Pilots express opinions of an airplane's longitudinal stability in terms of such factors as "stiffness" and of pitching or unsteadiness in flight through rough air, but the relation between these observed characteristics and the degree of stability as defined by the period and damping of the phugoid oscillation is unknown.

In the present tests, the period and damping of the phugoid oscillations of several airplanes were measured and, in addition, the general handling characteristics as related to longitudinal motions were observed. The measurements were made to obtain information on the degree of stability to be expected in conventional airplanes. The observations of the handling characteristics were made to determine whether there is any definite relationship between the stability as defined by period and damping of oscillations and the pilot's impression of handling characteristics. It was hoped that the tests would provide an indication of the degree of dynamic stability desired.

The theory of stability indicates that the period and damping of the phugoid oscillations are affected by engine power and elevator restraint as well as by speed. It was therefore desirable to make the measurements for several conditions. The tests were made with eight single-engine airplanes of different types:

two high-wing monoplanes and six biplanes. The weights ranged from 1,440 to 6,100 pounds and the engine powers from 95 to 575 horsepower. Where feasible, the measurements of period and damping were made for a speed range extending from 10 miles per hour above the minimum speed to the maximum speed in level flight for the following conditions:

1. Elevator fixed with throttle closed.
2. Elevator fixed with full throttle.
3. Elevator free with throttle closed.
4. Elevator free with full throttle.

The handling characteristics of each airplane were rated by each of two test pilots.

APPARATUS AND METHOD

The eight airplanes tested were the Fairchild 22, the Martin XBM-1, the Verville AT, the Martin T4M-1, the Fairchild FC2-W2, the Boeing F4B-2, the Consolidated NY-2, and the Douglas O-2H. The dimensions of these airplanes pertinent to their longitudinal-stability characteristics are given in table I. The weights and center-of-gravity locations given are for the airplanes as flown in the tests and do not represent full-load conditions. The NY-2 airplane has a fixed stabilizer that limited the elevator-free runs to one air speed.

The following procedure was employed in the tests: All runs were made at a mean pressure altitude of approximately 3,000 feet. Steady conditions were first obtained at a given speed. For the elevator-free runs the stabilizer was adjusted to obtain trim at this speed. The oscillations were induced by depressing the nose of the airplane with the elevator until a steady speed of approximately 5 miles per hour above the initial flight speed was obtained. The elevator was then immediately returned to the original setting for the elevator-fixed runs or freed for the elevator-free runs. Adjustable stops were provided for the elevator-fixed runs to assist the pilot in resetting the elevator to the original position and in holding it fixed during the oscillations.

The air speed was used for the determination of the period and damping of the oscillations. The variation of air speed with time was obtained by means of a recording air-speed meter and timer started prior to the start of the oscillations. The record of air speed was obtained for at least two complete cycles of oscillation. The period of the oscillation was, of course, the time between successive peaks on the air-speed record. The damping factor ζ was computed by the equation

$$\zeta = \frac{2}{P} \log_e \frac{V_3 - V_2}{V_1 - V_2} \quad (\text{from reference 2})$$

where P is the period in seconds, V_1 and V_3 are the true air speeds in feet per second at successive maximums, and V_2 the air speed at the intervening mini-

mum. The time T required for an oscillation to damp to one-half amplitude was obtained by the equation

$$T = \frac{-0.693}{\zeta}$$

The period and the time to damp to one-half amplitude were plotted as functions of the mean air speed during the oscillation.

RESULTS AND DISCUSSION

The results of the measurements are given in figures 1 to 4. The figures show that the period and the damping vary considerably with speed for a given condition, between different conditions, and among different airplanes. The condition with the elevator fixed with throttle closed (fig. 1) is the only one which is completely covered by the theory at the present time and for which the stability derivatives may be readily computed. For this condition, all the airplanes were stable in the speed ranges covered by the tests. The curves show an almost linear increase of period with the velocity of flight and, with the exception of the results for the O-2H airplane, there is very little difference between the curves for the different airplanes. Longitudinal-stability theory indicates that the period may be approximated by the equation

$$P = 0.142(2+a)^{1/2}V$$

where V is the velocity in miles per hour, and a is a variable dependent on the aerodynamic characteristics but which does not change greatly for conventional airplanes. Computations made on the basis of figure 1 show that a constant value of 1.4 for a is satisfactory for approximating the period of conventional airplanes for the speed range of the tests for the power-off elevator fixed condition. The equation would then reduce to

$$P = 0.262V$$

The damping is a more critical stability characteristic than the period and, consequently, the damping curves show more dispersion than those for the period. The times for an oscillation to damp to one-half amplitude show a slight general tendency to decrease with increasing velocity. In general, the number of cycles required to damp to one-half amplitude varies inversely as the period.

The effect of power on the stability characteristics is shown by a comparison of the curves of figure 2, for the elevator fixed with full throttle, with the curves of figure 1. The periods of the oscillations are generally longer with full throttle than with the throttle closed. The damping is less, that is, the time required to damp to one-half amplitude is longer. The power effects are greatest at low speeds where the propeller thrust and the ratio of slipstream velocity to forward speed are greatest. All of the airplanes with the exception of the

T4M-1 showed a tendency toward dynamic instability at low speeds with power on. Four airplanes, the O-2H, the F4B-2, the AT, and the NY-2, actually became unstable within the speed range covered by the tests. The instability existed in the form of an increase in the amplitude of the oscillations with time. No case of instability in the form of continuous divergence from steady conditions, corresponding to a positive slope of the pitching-moment curve or static instability, was encountered in the tests.

Figures 3 and 4 present the results for the elevator-free tests. A comparison of figures 1, 2, and 3 shows

open. With elevator free, it was unstable with the throttle closed and stable with the throttle open.

Table II has been prepared to show the test conditions for which instability was recorded for the various airplanes. As will be noted, only the F-22 and the T4M-1 were stable for all test conditions and speeds. The FC2-W2 and the XBM-1 were stable for three of the four test conditions. The F4B-2, AT, and O-2H airplanes were completely stable for only two conditions. The NY-2 airplane was unstable for only one condition but, since this airplane had a fixed stabilizer, the elevator-free runs were made at only one speed.

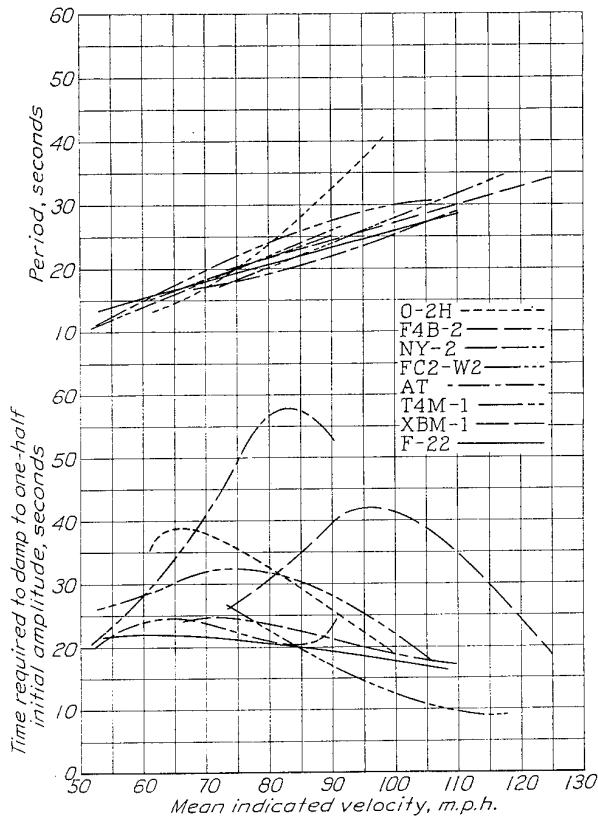

FIGURE 1.—Period and damping of longitudinal oscillations with elevator fixed and power off.

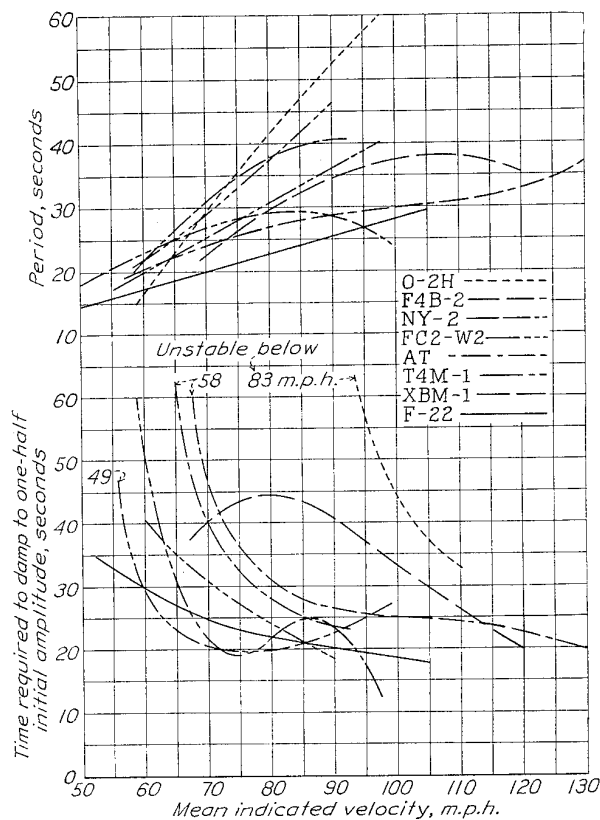

FIGURE 2.—Period and damping of longitudinal oscillations with elevator fixed and power on.

that the stability characteristics are considerably less affected by freeing the elevator than by applying power. The periods are slightly shorter with free elevator than with the elevator fixed. The damping is decreased, but only the results for the O-2H airplane show instability. All the airplanes had statically unbalanced elevators. For elevators equipped with mass balances, as is usual with more modern airplanes, the differences between the elevator-fixed and elevator-free stability would probably be less than that recorded.

For most cases power has the same general effect of decreasing the period and damping with the elevator free as with it fixed. The O-2H airplane is an exception. This airplane with the elevator fixed was stable with the throttle closed and unstable with the throttle

The range for periods of oscillations given by the results for all test conditions extends from 11 seconds, for the F-22 airplane at 60 miles per hour in gliding flight with the elevator free, to 64 seconds, for the O-2H airplane at 102 miles per hour with the elevator fixed and power on. It has been noted previously that, for the power-off elevator-fixed condition, all airplanes except the O-2H had approximately the same period at any given speed. If all test conditions are taken into consideration, however, fairly large variations of the periods at a given speed are noted. At 60 miles per hour, the shortest period is 11 seconds and the longest 23 seconds. At 102 miles per hour, the shortest period is 23 seconds and the longest 64 seconds. It is of

interest to note that for most airplanes and test conditions the maximum period is about 45 seconds.

The times for the oscillation to subside to one-half amplitude vary from infinity for the cases of instability previously discussed to 9 seconds for the FC2-W2 airplane in gliding flight at 118 miles per hour with the elevator fixed. On the basis of the number of cycles, this damping corresponds to a reduction of the amplitude to one-half in approximately one-fourth cycle. The damping shows no definite trend with speed of flight, so ranges at different speeds are of no importance.

Table III shows alphabetical ratings of the airplanes based on measured stability characteristics as compared with pilots' ratings based on observed longitudinal

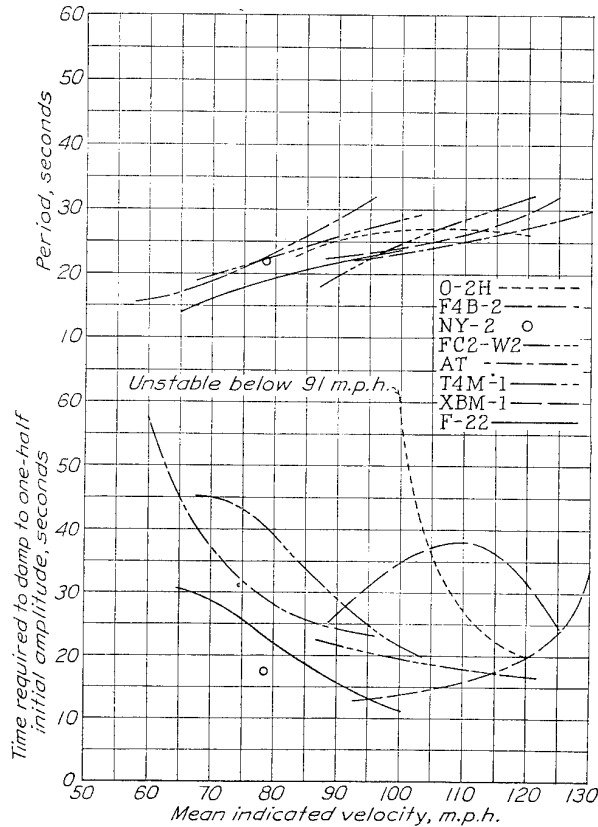

FIGURE 3.—Period and damping of longitudinal oscillations with elevator free and power off.

control and handling qualities. It will be appreciated that any ratings made on the basis of the measurements for comparison with the pilots' ratings can only be approximate and represent average conditions. The ratings for the period given in table III consider the entire speed range. The shortest period is designated A. The periods increase in alphabetical order. The ratings for damping consider primarily the higher portion of the speed range where most flying is done and where most of the airplanes are stable. The greatest damping is designated A.

The magnitude of the elevator forces and movements required for normal operation of an airplane, through

their partial dependence on the slope of the pitching-moment curve, are indirectly related to the stability as defined by the period and damping of the longitudinal oscillation. The relationship has resulted in the use of the loosely defined piloting term "stiffness" to describe the combined longitudinal stability and control characteristics. The general usage of the term has made it desirable to make it one of the bases for rating the airplanes, although it is appreciated that the ratings given depend on the interpretation of only two pilots and might be somewhat different from those that would have been obtained had more pilots been consulted. In table III, the stiffest airplane has been designated A.

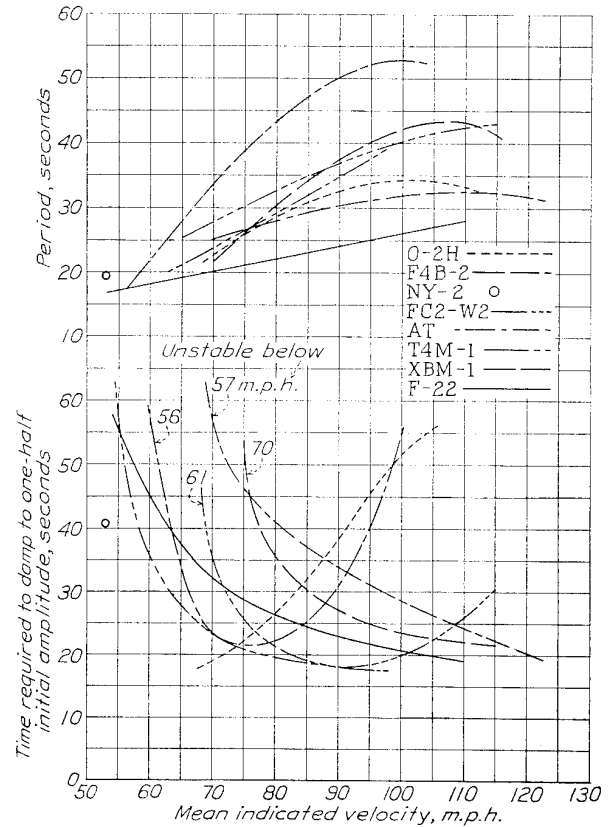

FIGURE 4.—Period and damping of longitudinal oscillations with elevator free and power on.

Because stiffness does include the elevator force and movements, pilots prepared separate ratings on the basis of these two items. The airplane with the heaviest elevator control and the one requiring the greatest elevator movements are designated A. A rating was also prepared on the basis of the amount of pitching occurring during flight in rough air. In this case, A designated the airplane doing the most pitching or being the unsteadiest in flight in rough air.

A comparison of the different ratings prepared by the pilots shows that the ratings for stiffness are almost identical with those for elevator force. Aside from the fact that stiffness is given in four gradations and the elevator force in three, the T4M-1 airplane is the only

one for which there is actual disagreement. This airplane was the largest of the group tested and had a wheel control. The pilots associate heavier forces with a wheel than with stick control and rate airplanes for stiffness accordingly. Apparently, at least for the Committee's pilots, stiffness refers primarily to elevator force with consideration taken of the size of the airplane and type of control. The ratings for elevator movement show that there is a tendency for large elevator forces to be associated with large elevator movements. The ratings for pitching in rough air show no correlation with those for any other item.

In the vibration of springs, the period of oscillation varies in an inverse ratio to the spring stiffness. By analogy the airplane having the shortest period may be considered the stiffest. From the listings on table III, it will be noted that the pilots' ratings for stiffness are in almost direct opposition to the stiffness as indicated by the period. There are too many variables involved to determine the reason for the reverse order for the two ratings, but the conclusions cannot be drawn that this reverse order will occur for all airplanes. The disagreement, however, indicates that elevator forces and period are not closely enough related to the slope of the pitching-moment curve to assume that high forces and a short period will result from a large negative slope to the curve. Neither can the ratings for damping be correlated with the pilots' observations of stiffness. Likewise, there is no apparent correlation between the pilots' ratings for pitching or unsteadiness in rough air and either the measured periods or the damping. It is also of interest to note, in connection with the lack of correlation of the measured dynamic stability characteristics and the characteristics observed by the pilots, that the instability of the oscillations for the power-on conditions for several of the airplanes had no appreciable effect on their flying characteristics and was not noted by the pilots prior to the tests.

It is evident from the foregoing comparisons that the dynamic longitudinal stability characteristics, as defined by the period and damping of the phugoid oscillation, are not apparent to the pilot and, therefore, cannot be taken as an indication of the handling characteristics of airplanes. If the most desirable degree of dynamic stability is to be determined, factors other than the handling characteristics will have to be considered. The reaction of the airplane to rough-air conditions appears to offer a possible basis. The pitch-

ing in rough air, from the present tests, does not appear to be related to the phugoid oscillation. It may, however, be related to the short-period oscillation, and this possibility should perhaps be investigated. Fisher (reference 3) shows that the structural loads imposed by gusts are influenced by the stability derivatives.

CONCLUSIONS

1. The period of the phugoid longitudinal oscillations for the eight airplanes tested varied from 11 seconds at low speeds to 64 seconds at high speeds. For the elevator-fixed power-off condition the period for conventional airplanes may be approximated by the equation

$$P=0.262V$$

2. The maximum damping encountered in the tests was sufficient to reduce the amplitude of oscillation to one-half in 9 seconds, or in approximately one-fourth cycle.

3. Four of the eight airplanes were dynamically unstable with power on although all were stable with power off and the elevator fixed and only one was unstable with power off and the elevator free, indicating the importance of the effect of power upon the stability characteristics.

4. The dynamic longitudinal stability of airplanes, as defined by the period and damping of the phugoid oscillation, has no apparent bearing on the factors from which pilots judge the handling characteristics.

LANGLEY MEMORIAL AERONAUTICAL LABORATORY,
NATIONAL ADVISORY COMMITTEE FOR AERONAUTICS,
LANGLEY FIELD, VA., July 15, 1936.

REFERENCES

1. Zimmerman, Charles H.: An Analysis of Longitudinal Stability in Power-Off Flight with Charts for Use in Design. T. R. No. 521, N. A. C. A., 1935.
2. Soulé, Hartley A., and Wheatley, John B.: A Comparison between the Theoretical and Measured Longitudinal Stability Characteristics of an Airplane. T. R. No. 442, N. A. C. A., 1932.
3. Fisher, H. R.: The Normal Acceleration Experienced by Aeroplanes Flying through Vertical Air Currents. Part I. The Calculation of the Acceleration Experienced by an Aeroplane Flying through a Given Gust. R. & M. No. 1463, British A. R. C., 1932.

TABLE I
CHARACTERISTICS OF AIRPLANES TESTED

Airplane.....	Fairchild 22	Martin XBM-1	Verville AT	Martin T4M-1	Fairchild FC2-W2	Boeing F4B-2	Consolidated NY-2	Douglas O-2H
Type.....	Parasol mono-plane	Biplane	Biplane	Biplane	High-wing mono-plane	Biplane	Biplane	Biplane
Wing area (sq. ft.).....	171	412	242	656	336	236	370	368
Weight (lb.).....	1,440	6,100	2,300	5,824	4,510	2,875	2,769	4,960
Engine horsepower.....	95	575	165	525	450	300	220	400
Wing loading (lb./sq. ft.).....	8.4	14.8	9.5	8.9	13.4	12.2	7.5	13.5
Power loading (lb./hp.).....	15.2	10.6	13.9	11.1	10.0	5.75	18.2	12.4
Wing dimensions:								
Span upper (ft.).....	32.83	41.0	31.0	53.0	50.0	30.0	40.0	40.17
Span lower (ft.).....		40.0	31.0	53.0		26.33	40.0	38.67
Chord upper (ft.).....	5.5	6.17	4.17	6.58	7.0	5.0	5.0	5.0
Chord lower (ft.).....		5.42	4.17	6.58		3.75	5.0	5.0
Gap (ft.).....		6.17	5.0	7.5		4.87	4.96	6.0
Stagger (ft.).....		2.58	2.13	0		2.67	2.33	1.85
Wing setting (deg.).....	1.0	0	0	2.0	2.6	0	2.0	2.0
Airfoil section.....	N-22	N-22	Clark Y-15	Clark Y-15	Göttingen 387	Boeing 106	Clark Y	Göttingen 398
Mean aerodynamic chord (ft.).....	5.50	5.66	4.17	6.58	7.0	4.60	5.00	5.00
Leading edge to leading edge of lower wing {vertical (ft.).....	.13	3.60	2.92	4.03	.25	3.30	2.83	3.48
{horizontal (ft.).....	0	.92	1.18	0	0	2.05	1.33	.99
Tail dimensions:								
Span (ft.).....	10.0	14.0	10.0	18.92	11.6	12.17	12.27	13.92
Stabilizer area (sq. ft.).....	15.8	28.4	16.6	54.5	28.6	19.9	17.3	23.8
Elevator area (sq. ft.).....	10.4	25.6	13.3	30.0	17.6	17.9	17.6	23.1
Elevator hinge to leading edge of lower wing {vertical (ft.).....	-2.0	3.0	2.3	5.5	7	2.17	4.25	4.06
{horizontal (ft.).....	14.69	18.20	15.4	24.0	25.34	12.53	18.18	20.71
c. g. location:								
Relative to M. A. C. {vertical } percent of M. A. C.....	-52.3	-35.8	-21.6	-21.7	-29.0	-32.8	-18.2	1.2
{horizontal } percent of M. A. C.....	28.0	29.7	33.1	30.9	30.6	38.5	28.6	36.6
Relative to thrust axis (ft.).....	-1.30	-1.38	.08	-1.40	.83	.12	-1.08	1.41

TABLE II
SUMMARY OF DYNAMICALLY STABLE AND UNSTABLE CONDITIONS OF AIRPLANES TESTED

[S, stable; U, unstable]

Airplane	Elevator fixed throttle closed	Elevator fixed full throttle	Elevator free throttle closed	Elevator free full throttle
Fairchild 22.....	S	S	S	S
Martin T4M-1.....	S	S	S	S
Consolidated NY-2.....	S	U below 49 m. p. h.	S	S
Boeing F4B-2.....	S	U below 58 m. p. h.	S	U below 56 m. p. h.
Verville AT.....	S	U below 58 m. p. h.	S	U below 57 m. p. h.
Douglas O-2H.....	S	U below 83 m. p. h.	U below 91 m. p. h.	S
Fairchild FC2-W2.....	S	S	S	U below 61 m. p. h.
Martin XBM-1.....	S	S	S	U below 70 m. p. h.

TABLE III
RATING OF LONGITUDINAL STABILITY AND HANDLING QUALITIES OF AIRPLANES TESTED

Airplane	Observed characteristics				Measured characteristics	
	Stiffness	Factors affecting stiffness			Period	Damping
		Elevator force	Elevator movement	Pitching in rough air		
Fairchild 22.....	D	C	B	A	A	A
Martin T4M-1.....	C	A	A	B	B	B
Consolidated NY-2.....	C	B	B	A	B	B
Boeing F4B-2.....	D	C	C	B	A	C
Verville AT.....	C	C	B	B	D	B
Douglas O-2H.....	A	A	A	A	D	D
Fairchild FC2-W2.....	B	B	B	B	C	A
Martin XBM-1.....	A	A	C	D	C	D

A is used to designate airplanes that are stiffest, require the greatest elevator forces and movement, do most pitching in rough air, and have the shortest periods and the greatest damping.

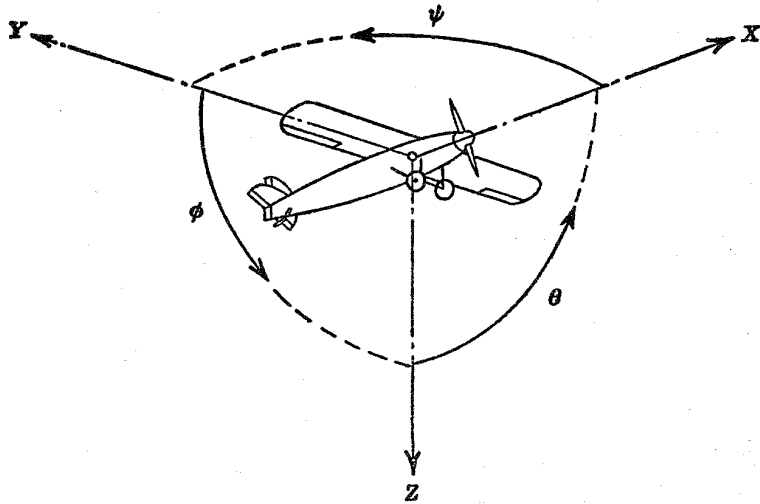

Positive directions of axes and angles (forces and moments) are shown by arrows

Axis		Force (parallel to axis) symbol	Moment about axis			Angle		Velocities	
Designation	Sym- bol		Designation	Sym- bol	Positive direction	Designa- tion	Sym- bol	Linear (compo- nent along axis)	Angular
Longitudinal....	X	X	Rolling.....	L	Y→Z	Roll.....	φ	u	p
Lateral.....	Y	Y	Pitching.....	M	Z→X	Pitch.....	θ	v	q
Normal.....	Z	Z	Yawing.....	N	X→Y	Yaw.....	ψ	w	r

Absolute coefficients of moment

$$C_l = \frac{L}{qbS}$$

(rolling)

$$C_m = \frac{M}{qcS}$$

(pitching)

$$C_n = \frac{N}{qbS}$$

(yawing)

Angle of set of control surface (relative to neutral position), δ . (Indicate surface by proper subscript.)

4. PROPELLER SYMBOLS

D , Diameter

p , Geometric pitch

p/D , Pitch ratio

V_i , Inflow velocity

V_s , Slipstream velocity

T , Thrust, absolute coefficient $C_T = \frac{T}{\rho n^2 D^4}$

Q , Torque, absolute coefficient $C_Q = \frac{Q}{\rho n^2 D^5}$

P , Power, absolute coefficient $C_P = \frac{P}{\rho n^3 D^5}$

C_s , Speed-power coefficient = $\sqrt[5]{\frac{\rho V_i^5}{P n^2}}$

η , Efficiency

n , Revolutions per second, r.p.s.

Φ , Effective helix angle = $\tan^{-1} \left(\frac{V}{2\pi r n} \right)$

5. NUMERICAL RELATIONS

1 hp. = 76.04 kg-m/s = 550 ft-lb./sec.

1 metric horsepower = 1.0132 hp.

1 m.p.h. = 0.4470 m.p.s.

1 m.p.s. = 2.2369 m.p.h.

1 lb. = 0.4536 kg.

1 kg = 2.2046 lb.

1 mi. = 1,609.35 m = 5,280 ft.

1 m = 3.2808 ft.