

Ray J. Williams

NATIONAL ADVISORY COMMITTEE FOR AERONAUTICS

REPORT No. 560

A SIMPLIFIED APPLICATION OF THE METHOD OF OPERATORS TO THE CALCULATION OF DISTURBED MOTIONS OF AN AIRPLANE

By ROBERT T. JONES

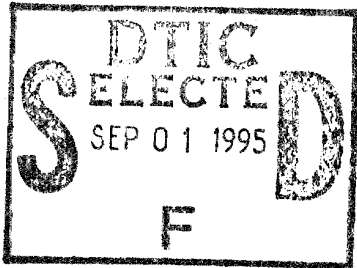

DISTRIBUTION STATEMENT A
Approved for public release
Distribution Unlimited

~~SECRET~~
~~RESTRICTED~~
~~CONFIDENTIAL~~
173944

173944
446661

19950828 129

1936

DTIC QUALITY INSPECTED 8

AERONAUTIC SYMBOLS

1. FUNDAMENTAL AND DERIVED UNITS

	Symbol	Metric		English	
		Unit	Abbrevia- tion	Unit	Abbrevia- tion
Length.....	l	meter.....	m	foot (or mile).....	ft. (or mi.)
Time.....	t	second.....	s	second (or hour).....	sec. (or hr.)
Force.....	F	weight of 1 kilogram.....	kg	weight of 1 pound.....	lb.
Power.....	P	horsepower (metric).....		horsepower.....	hp.
Speed.....	V	{kilometers per hour..... meters per second.....	{k.p.h. m.p.s.	{miles per hour..... feet per second.....	{m.p.h. f.p.s.

2. GENERAL SYMBOLS

<p>W, Weight = mg</p> <p>g, Standard acceleration of gravity = 9.80665 m/s² or 32.1740 ft./sec.²</p> <p>m, Mass = $\frac{W}{g}$</p> <p>I, Moment of inertia = mk^2. (Indicate axis of radius of gyration k by proper subscript.)</p> <p>μ, Coefficient of viscosity</p>	<p>ν, Kinematic viscosity</p> <p>ρ, Density (mass per unit volume)</p> <p>Standard density of dry air, 0.12497 kg-m⁻⁴-s² at 15° C. and 760 mm; or 0.002378 lb.-ft.⁻⁴ sec.²</p> <p>Specific weight of "standard" air, 1.2255 kg/m³ or 0.07651 lb./cu.ft.</p>
--	---

3. AERODYNAMIC SYMBOLS

<p>S, Area</p> <p>S_w, Area of wing</p> <p>G, Gap</p> <p>b, Span</p> <p>c, Chord</p> <p>$\frac{b^2}{S}$, Aspect ratio</p> <p>V, True air speed</p> <p>q, Dynamic pressure = $\frac{1}{2}\rho V^2$</p> <p>L, Lift, absolute coefficient $C_L = \frac{L}{qS}$</p> <p>D, Drag, absolute coefficient $C_D = \frac{D}{qS}$</p> <p>D_o, Profile drag, absolute coefficient $C_{D_o} = \frac{D_o}{qS}$</p> <p>D_i, Induced drag, absolute coefficient $C_{D_i} = \frac{D_i}{qS}$</p> <p>D_p, Parasite drag, absolute coefficient $C_{D_p} = \frac{D_p}{qS}$</p> <p>C, Cross-wind force, absolute coefficient $C_C = \frac{C}{qS}$</p> <p>R, Resultant force</p>	<p>i_w, Angle of setting of wings (relative to thrust line)</p> <p>i_t, Angle of stabilizer setting (relative to thrust line)</p> <p>Q, Resultant moment</p> <p>Ω, Resultant angular velocity</p> <p>$\rho \frac{Vl}{\mu}$, Reynolds Number, where l is a linear dimension (e.g., for a model airfoil 3 in. chord, 100 m.p.h. normal pressure at 15° C., the corresponding number is 234,000; or for a model of 10 cm chord, 40 m.p.s. the corresponding number is 274,000)</p> <p>C_p, Center-of-pressure coefficient (ratio of distance of <i>c.p.</i> from leading edge to chord length)</p> <p>α, Angle of attack</p> <p>ϵ, Angle of downwash</p> <p>α_o, Angle of attack, infinite aspect ratio</p> <p>α_i, Angle of attack, induced</p> <p>α_a, Angle of attack, absolute (measured from zero-lift position)</p> <p>γ, Flight-path angle</p>
--	--

REPORT No. 560

A SIMPLIFIED APPLICATION OF THE METHOD OF OPERATORS TO THE CALCULATION OF DISTURBED MOTIONS OF AN AIRPLANE

By ROBERT T. JONES

Langley Memorial Aeronautical Laboratory

63689-36-1

Accession For	
NTIS CRA&I	<input checked="" type="checkbox"/>
DTIC TAB	<input type="checkbox"/>
Unannounced	<input type="checkbox"/>
Justification _____	
By _____	
Distribution /	
Availability Codes	
Dist	Avail and/or Special
A-1	

1

NATIONAL ADVISORY COMMITTEE FOR AERONAUTICS

HEADQUARTERS, NAVY BUILDING, WASHINGTON, D. C.

LABORATORIES, LANGLEY FIELD, VA.

Created by act of Congress approved March 3, 1915, for the supervision and direction of the scientific study of the problems of flight (U. S. Code, Title 50, Sec. 151). Its membership was increased to 15 by act approved March 2, 1929. The members are appointed by the President, and serve as such without compensation.

JOSEPH S. AMES, Ph. D., *Chairman*,
Baltimore, Md.

DAVID W. TAYLOR, D. Eng., *Vice Chairman*,
Washington, D. C.

CHARLES G. ABBOT, Sc. D.,
Secretary, Smithsonian Institution.

LYMAN J. BRIGGS, Ph. D.,
Director, National Bureau of Standards.

ARTHUR B. COOK, Rear Admiral, United States Navy,
Chief, Bureau of Aeronautics, Navy Department.

WILLIS RAY GREGG, B. A.,
United States Weather Bureau.

HARRY F. GUGGENHEIM, M. A.,
Port Washington, Long Island, N. Y.

SYDNEY M. KRAUS, Captain, United States Navy,
Bureau of Aeronautics, Navy Department.

CHARLES A. LINDBERGH, LL. D.,
New York City.

WILLIAM P. MACCRACKEN, JR., LL. D.,
Washington, D. C.

AUGUSTINE W. ROBINS, Brigadier General, United States Army,
Chief Matériel Division, Air Corps, Wright Field, Dayton,
Ohio.

EUGENE L. VIDAL, C. E.,
Director of Air Commerce, Department of Commerce.

EDWARD P. WARNER, M. S.,
New York City.

OSCAR WESTOVER, Major General, United States Army,
Chief of Air Corps, War Department.

ORVILLE WRIGHT, Sc. D.,
Dayton, Ohio.

GEORGE W. LEWIS, *Director of Aeronautical Research*

JOHN F. VICTORY, *Secretary*

HENRY J. E. REID, *Engineer in Charge, Langley Memorial Aeronautical Laboratory, Langley Field, Va.*

JOHN J. IDE, *Technical Assistant in Europe, Paris, France*

TECHNICAL COMMITTEES

AERODYNAMICS

POWER PLANTS FOR AIRCRAFT

AIRCRAFT STRUCTURES AND MATERIALS

AIRCRAFT ACCIDENTS

INVENTIONS AND DESIGNS

Coordination of Research Needs of Military and Civil Aviation

Preparation of Research Programs

Allocation of Problems

Prevention of Duplication

Consideration of Inventions

LANGLEY MEMORIAL AERONAUTICAL LABORATORY

LANGLEY FIELD, VA.

Unified conduct, for all agencies, of
scientific research on the fundamental
problems of flight.

OFFICE OF AERONAUTICAL INTELLIGENCE

WASHINGTON, D. C.

Collection classification, compilation,
and dissemination of scientific and technical
information on aeronautics.

E R R A T A

NATIONAL ADVISORY COMMITTEE FOR AERONAUTICS

TECHNICAL REPORT NO. 560

A SIMPLIFIED APPLICATION OF THE
METHOD OF OPERATORS TO THE CALCULATION OF
DISTURBED MOTIONS OF AN AIRPLANE

Page 5, column 1, equation (15):

For	$= \frac{R_2}{R_1 R_3} e^{\lambda_1 t} + i(\theta_2 - \theta_1 - \theta_3)$	Read	$= \frac{R_2}{R_1 R_3} e^{\lambda_1 t + i(\theta_2 - \theta_1 - \theta_3)}$
	$= R_0 e^{\lambda_1 t} + i\theta_0$		$= R_0 e^{\lambda_1 t + i\theta_0}$

Page 6, legend of figure 3:

For	$\frac{f(\lambda)}{F'(\lambda)}$	Read	$\frac{f(\lambda)}{\lambda F'(\lambda)}$
-----	----------------------------------	------	--

Page 8, column 2, second line of equation (32):

For	$(D - L_0)p$	Read	$(D - L_p)p$
-----	--------------	------	--------------

REPORT No. 560

A SIMPLIFIED APPLICATION OF THE METHOD OF OPERATORS TO THE CALCULATION OF DISTURBED MOTIONS OF AN AIRPLANE

By ROBERT T. JONES

SUMMARY

A simplified treatment of the application of Heaviside's operational methods to problems of airplane dynamics is given. Certain graphical methods and logarithmic formulas that lessen the amount of computation involved are explained.

The problem of representing a gust disturbance or control manipulation is taken up and it is pointed out that in certain cases arbitrary control manipulations may be dealt with as though they imposed specific constraints on the airplane, thus avoiding the necessity of any integration whatever.

The application of the calculations described in the text is illustrated by several examples chosen to show the use of the methods and the practicability of the graphical and logarithmic computations described.

INTRODUCTION

The theory of airplane dynamics in its present form is due mainly to the original researches of Lanchester and Bryan on the stability of airplanes. Later investigators, notably Bairstow and Wilson (reference 1), applied and extended the original conceptions of the theory. Bryant and Williams (reference 2) have recently shown how the operational mathematics of Heaviside may be used in applying the theory to problems of the disturbed motions of airplanes.

Although the calculation of disturbed motions of aircraft is important in problems of flight safety, little experience has been gained in the practical application of the theory owing to its mathematical complexity. The present paper gives the results of researches in the mathematical application of the theory. It has been found, as suggested by Bryant and Williams, that the Heaviside method affords the simplest and most direct solution of these problems. In order to bring out the advantages of this method, a treatment of its application is given and certain formulas and graphical constructions are explained that make the calculations easier.

In their usual form, problems of airplane dynamics depend for solution on the integration of simultaneous linear differential equations. Methods for the integra-

tion of such equations are given by Wilson and Routh (references 1 and 3) and in mathematical textbooks. The problems met in airplane dynamics are often more complex than the examples treated in textbooks and, when an attempt is made to apply the given methods to their solution, difficulties of computation arise.

In view of the importance of investigating these problems and since their solutions involve lengthy calculations, it is desirable that as many mathematical simplifications as possible be employed. Heaviside's method gives such a simplification, the solution of the differential equations being accomplished symbolically by a single "expansion theorem."

THE DIFFERENTIAL EQUATIONS FOR THE DISTURBED MOTIONS

An airplane in uniform flight may be thought of as a free rigid body in equilibrium. Deviations of the airplane from this equilibrium condition may be caused by reactions due to control movement, gustiness in the air, or by some influence such as the stopping of an engine. The motions of the airplane following such a disturbance may be calculated if the momentary accelerations or forces are known. It is obvious that this computation may be performed by taking small intervals of the time and calculating the velocities and displacements generated by the known accelerations step by step, assuming the accelerations momentarily constant.

The component linear and angular motions of the airplane in its deviations from equilibrium are given exact definition by constructing a set of axes rigidly fixed in the machine and considering its motions as being those of the axes themselves. The motions spoken of are then velocities and displacements of the airplane axes relative to the earth or the air. When the airplane is in steady flight, it maintains a certain equilibrium attitude with respect to the air and to the earth. Thus for climbing flight at a given engine speed a definite angle of attack and a definite angle of pitch must be preserved. Deviations from equilibrium in either sense will introduce reactions; hence motions of the airplane axes relative to both air and earth must be considered.

The aerodynamic reactions to the motions arise from changed relative air velocities over the different parts of the airplane. The calculation or measurement of these component aerodynamic reactions leads to quantities known as "resistance derivatives" or "stability derivatives," which are taken as constant factors of proportionality between the reactions and the velocities or displacements of the motions. For a more detailed exposition of the concept of stability derivatives, the reader is referred to standard textbooks on aeronautics.

On account of the bilateral symmetry of the airplane it is customary to divide the motions into two independent groups, the lateral and the longitudinal, each consisting of three degrees of freedom:

- | | | | |
|--------------------------|-------|--|--|
| (A) Lateral motions | ----- | { Rolling.
Yawing.
Sideslipping. | |
| (B) Longitudinal motions | ---- | | { Pitching.
Vertical translation.
Forward translation. |

Presumably the reactions to small increments of longitudinal speed or displacement do not sensibly influence the lateral motions and the two groups may be independently treated. In order to illustrate the calculation of the history of a motion due to a given disturbance, examples of lateral motions are chosen although the methods used are equally applicable to any set of degrees of freedom of the airplane. The quantities that arise in the consideration of the lateral motions are defined in the following table:

- Velocities and displacements of airplane axes:
- U_0 , equilibrium flight velocity along X axis.
 - v , component of flight velocity along Y axis (sideslipping).
 - p , component of angular velocity about X axis (rolling).
 - r , component of angular velocity about Z axis (yawing).
 - ϕ , angle of bank (relative to gravity).
- Forces and moments resolved along airplane axes:
- Y , component of force along Y axis.
 - L , component of moment about X axis (rolling moment).
 - N , component of moment about Z axis (yawing moment).
- Accelerations of airplane:
- $Y_0 = Y/m$ (force per unit mass).
 - $L_0 = L/mk_x^2$ (moment per unit moment of inertia).
 - $N_0 = N/mk_z^2$ (moment per unit moment of inertia).
- Gust velocities resolved along airplane axes:
- v_0 , component of gust velocity directed along Y axis.
 - r_0 , component of angular velocity of gust about Z axis.
 - p_0 , component of angular velocity of gust about X axis.

NOTE.—The signs of the gust velocities are so chosen that a positive gust produces the same aerodynamic reaction on the airplane as a positive velocity of the airplane in still air. The resolution of gust velocities along the moving axes is exact only to the first order of the small quantities involved.

Airplane characteristics used as parameters:

Y_v	} Stability derivatives in terms of accelerations of airplane, thus:	
Y_r		
L_p		$Y_v = \frac{\partial Y}{\partial v} / m$
L_v		
L_r		$L_r = \frac{\partial L}{\partial r} / mk_x^2$
N_v		
N_p		$N_p = \frac{\partial N}{\partial p} / mk_z^2$
N_r		

With the definition of the component motions that are to be considered, the stability derivatives will be of the form:

$$\frac{\partial L}{\partial p}, \frac{\partial N}{\partial v}, \frac{\partial Y}{\partial r}, \text{ etc.}$$

where L , N , Y , respectively, are the rolling moment, the yawing moment, and the sidewise force, as they are customarily defined.

It has been found convenient to transform all stability derivatives and disturbing effects into terms of accelerations of the airplane rather than retaining them as moments and forces. This transformation is accomplished by dividing out the appropriate moments of inertia and the mass of the machine.

For example, $\frac{\partial L}{\partial p} / mk_x^2$ may be written simply as L_p ; similarly $\frac{\partial N}{\partial v} / mk_z^2 = N_v$ and $\frac{\partial Y}{\partial r} / m = Y_r$.

If the flight path is assumed to be horizontal (or nearly so) and the main forward velocity U_0 to be substantially constant, the equations of motion in a lateral disturbance may be written:

(In sideslipping)	$\frac{dv}{dt} = g\phi - rU_0 + vY_v + rY_r + Y_0$	} (1)
(In rolling)	$\frac{dp}{dt} = vL_v + pL_p + rL_r + L_0$	
(In yawing)	$\frac{dr}{dt} = vN_v + pN_p + rN_r + N_0$	

In these equations the terms Y_0 , L_0 , and N_0 represent known disturbing or controlling accelerations, assumed to be given as functions of the time t . In the first equation the terms $g\phi$ and $-rU_0$ are, respectively, the accelerations due to gravity and to the rotation of the moving axes. Since the axes chosen will ordinarily lie

near the axes of the principal moments of inertia of the airplane, terms involving the products of inertia have been neglected.

INTEGRATION OF EQUATIONS FOR VELOCITIES AND DISPLACEMENTS

As previously mentioned, equations (1) may be integrated by taking small intervals of the time and calculating the velocities, and finally the displacements, by assuming the accelerations $\frac{dv}{dt}$, etc., to be momentarily constant. Although this method is sometimes useful, it naturally leads to extensive numerical work. The operational mathematics of Heaviside appear to offer the most promising means of performing these integrations.

The first step in integrating the equations of motion by the operational method is to replace the symbol $\frac{d}{dt}$ by the so-called "differential operator" D , which is to be treated as though it were an ordinary algebraic quantity; the equations are then rearranged with the known disturbance effects on the right-hand side:

$$\begin{aligned} (D - Y_v)v - g\varphi + (U_0 - Y_r)r &= Y_0 \\ -L_v v + (D - L_p)p - L_r r &= L_0 \\ -N_v v - N_p p + (D - N_r)r &= N_0 \end{aligned} \tag{2}$$

Since $D\varphi = p$, the first equation may be operated on throughout by D , reducing all to the same variables (v, p, r):

$$\begin{aligned} D(D - Y_v)v - gDp + D(U_0 - Y_r)r &= DY_0 \\ -L_v v + (D - L_p)p - L_r r &= L_0 \\ -N_v v - N_p p + (D - N_r)r &= N_0 \end{aligned} \tag{2a}$$

With the equations in this form, they may be solved for $v, p, \text{ or } r$ by ordinary algebraic means; thus,

$$v = \frac{\begin{vmatrix} DY_0 & -g & D(U_0 - Y_r) \\ L_0 & (D - L_p) & -L_r \\ N_0 & -N_p & (D - N_r) \end{vmatrix}}{\begin{vmatrix} D(D - Y_v) & -g & D(U_0 - Y_r) \\ -L_v & (D - L_p) & -L_r \\ -N_v & -N_p & (D - N_r) \end{vmatrix}} \tag{3}$$

The expansion of the determinant of the numerator in terms of minors results in:

$$\begin{vmatrix} (D - L_p) & -L_r \\ -N_p & (D - N_r) \end{vmatrix} DY_0 + \begin{vmatrix} D(U_0 - Y_r) & -g \\ (D - N_r) & -L_r \end{vmatrix}$$

In the calculation of any of the velocity components the same denominator appears; if this determinant is denoted by $F(D)$, the forms of these components are:

$$\begin{aligned} v &= \frac{f_{11}(D)}{F(D)} Y_0 + \frac{f_{12}(D)}{F(D)} L_0 + \frac{f_{13}(D)}{F(D)} N_0 \\ p &= \frac{f_{21}(D)}{F(D)} Y_0 + \frac{f_{22}(D)}{F(D)} L_0 + \frac{f_{23}(D)}{F(D)} N_0 \end{aligned} \tag{5}$$

etc.

Thus far the solution of the equations of motion has progressed simply on algebraic grounds, the required quantities ($v, p, \text{ etc.}$) having been found explicitly in terms of the symbol D . The symbol D was defined as the operation of derivation with respect to the time t , expressed by writing

$$D = \frac{d}{dt}$$

The terms of the solution $f(D)/F(D)$ indicate that the formal operations are to be performed on whatever functions follow them as factors. Since they contain the symbol D in their denominators, it becomes necessary to define the operation indicated by $1/D$ or D^{-1} . As D is an operation and not a number, its reciprocal is defined as the inverse of the operation of differentiation, rather than as the derivative itself divided into 1. The inverse of differentiation is integration: thus,

$$D^{-1} = \int \dots dt$$

The operations indicated by the ratios of polynomials in D that occur in the terms of our solution then consist of a succession of differentiations, $[f(D)]$, and a succession of integrations, $[F(D)]^{-1}$. It is clear that the nature of the problems at hand requires that the resultant of these operations be an integration, which is shown by the fact that the polynomial $F(D)$ is invariably of higher degree in D than any of the polynomials $f(D)$.

THE EXPANSION EQUATION

By treating the disturbances (such as Y_0, N_0, L_0) as discontinuous functions of the time, Heaviside obtained solutions of equations similar to the foregoing by a simple theorem. The substitution of Y_0 into Heaviside's theorem results in

$$\frac{f(D)}{F(D)} Y_0 = Y_0 \left[\frac{f(0)}{F(0)} + \sum_{\lambda} \frac{f(\lambda)}{\lambda F'(\lambda)} e^{\lambda t} \right] \tag{6}$$

where the λ 's are the roots of the polynomial equation $F(D) = 0$. This polynomial, $F(D) = 0$, is used in the study of the stability of motion, being called the "stability equation." Its roots, $\lambda_1 \lambda_2 \dots \lambda_n$, give an

$$\begin{vmatrix} -g & D(U_0 - Y_r) \\ -N_p & -L_r \end{vmatrix} L_0 + \begin{vmatrix} -g & D(U_0 - Y_r) \\ (D - L_p) & -L_r \end{vmatrix} N_0 \tag{4}$$

indication of the natural tendencies of an airplane's motion and are used in the definition of stability.

In order to apply the foregoing theorem to the integration of equations of airplane motion it is necessary to assume that the disturbance terms (Y_0, N_0 , etc.) due to the control or gust in question are instantly applied at the assumed origin of the time scale ($t=0$) and remain constant thereafter. In the general case the disturbance terms in the equations of motion cannot be thus represented as remaining constant although in practical problems they may almost invariably be represented by means of functions of the form $Y_0 e^{nt}$. The interpretation of Heaviside's theorem equation (6) when this form of function is used is (see reference 2):

$$\frac{f(D)}{F(D)} Y_0 e^{nt} = Y_0 \left[\frac{f(n)}{F(n)} e^{nt} + \sum_{\lambda} \frac{f(\lambda)}{(\lambda-n)F'(\lambda)} e^{\lambda t} \right] \quad (7)$$

When dealing with variable disturbance terms, it is important to note that a discontinuity of the function representing the disturbance at $t=0$ is implied as in equation (6).

By the substitution of (in) for n in equation (7), expressions that can be used when the disturbances

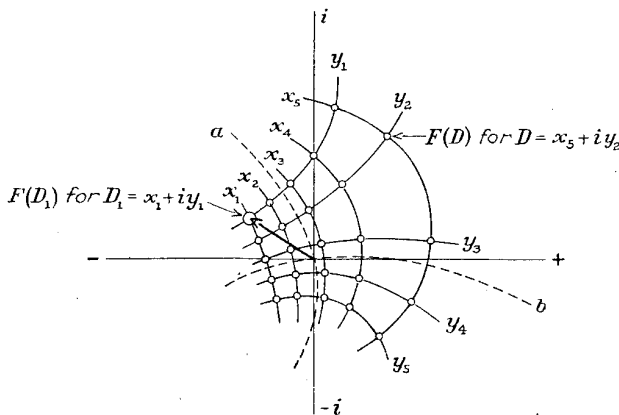

FIGURE 1.—Map of polynomial. $F(D) = D^4 + aD^3 + bD^2 + cD + d$ near zero. $F(D) \rightarrow F(\lambda) = 0$ when $D \rightarrow a \pm ib$.

are represented by forms involving $\sin nt$ or $\cos nt$ are obtained

$$\frac{f(D)}{F(D)} Y_0 e^{int} = Y_0 \left[\frac{f(in)}{F(in)} (\cos nt + i \sin nt) + \sum_{\lambda} \left(\frac{\lambda + in}{\lambda^2 + n^2} \right) \frac{f(\lambda)}{F'(\lambda)} e^{\lambda t} \right] \quad (7a)$$

If $\frac{f(in)}{F(in)} = A + iB$, then the expressions for the sine and cosine forms separately become

$$\frac{f(D)}{F(D)} Y_0 \sin nt = Y_0 \left[A \sin nt + B \cos nt + \sum_{\lambda} \left(\frac{n}{\lambda^2 + n^2} \right) \frac{f(\lambda)}{F'(\lambda)} e^{\lambda t} \right] \quad (8)$$

$$\frac{f(D)}{F(D)} Y_0 \cos nt = Y_0 \left[A \cos nt - B \sin nt + \sum_{\lambda} \left(\frac{\lambda}{\lambda^2 + n^2} \right) \frac{f(\lambda)}{F'(\lambda)} e^{\lambda t} \right] \quad (9)$$

These latter forms are particularly useful because almost any arbitrary variation of gust or control may be expressed as a sum of sine or cosine terms. Thus if

$$Y_0 = K_1 \sin n_1 t + K_2 \sin n_2 t + \dots + \text{etc.}$$

$$\frac{f(D)}{F(D)} Y_0 = \frac{f(D)}{F(D)} K_1 \sin n_1 t + \frac{f(D)}{F(D)} K_2 \sin n_2 t + \dots + \text{etc.} \quad (10)$$

Each of these terms may be evaluated by equation (8).

SOLUTION OF OPERATIONAL EQUATIONS

FINDING THE ROOTS OF THE EQUATION $F(D)=0$

The expansion equations given for the forms $f(D)/F(D)$ require the roots of the complementary equations $F(D)=0$ for their solution. In cases of airplane motions this equation is normally of the fourth degree in D ; hence it is not practicable to find the roots directly. Although a number of methods for approximating the roots of such equations have been devised, the most direct way is to draw a curve of the function $F(D)$ against D , locating the real roots as the points crossing the D axis. Usually in equations of this type near roots may be isolated by separating the equation into two parts. Thus, if

$$F(D) = D^4 + aD^3 + bD^2 + cD + d = 0 \quad (11)$$

there will usually be a large real root near $D^4 = -aD^3$, or $D = -a$, and a small one near $D = -\frac{d}{c}$. This division follows from the consideration that large roots are more dependent on the coefficients of the higher powers of D and small roots, on the lower powers.

If the natural motion of the airplane contains oscillatory components, as it usually does, there will be pairs of conjugate complex roots of the polynomial $F(D)=0$ in addition to the real roots. The determination of these roots is naturally more difficult, although if real roots have been previously found they may be used to reduce the degree of the equation by synthetic division and the determination of further roots will become progressively easier. Complex roots of such an equation may be directly found by plotting a map of the polynomial $F(D)$ for various values of D using the coordinates $D = x + iy$ and finding the zero point, or root, by interpolation, as is shown in figure 1. If a very accurate value of the root is required it may be convenient to plot the region of $F(D)$ near the origin to a magnified scale. Since the polynomial is what is known as an "analytic function" (reference 4),

$$\frac{\partial F(D)}{\partial x} = -i \frac{\partial F(D)}{\partial y} \quad (12)$$

and the map in its smallest parts will consist of squares. In this way a more accurate interpolation may be made or a process analogous to Newton's method may be applied.

It will be found most convenient to calculate the various values of $F(D)$ by means of a vector diagram

as shown in figure 2. If trial values of D are expressed in the form $\bar{R}(\cos \theta + i \sin \theta)$ or $Re^{i\theta}$, vectors representing each of the terms of the polynomial may be simply calculated. The problem is to make all terms of the polynomial balance each other and it is readily seen how this may be accomplished by varying θ to change the relative inclinations of the vectors and by varying R to change their relative lengths. The advantage of this method is that it enables a close approximation of the value of a root with a minimum number of trials, the diagram making apparent how nearly all the vectors cancel each other.

SOLUTION OF EXPANSION EQUATIONS

The numerical operations indicated in the expansion equations (6) to (9) call for calculations with complex numbers (i. e., roots of $F(D)=0$). A great deal of the labor involved in these computations may be saved by the use of graphical and logarithmic methods.

Thus, if it is desired to calculate values of the complex terms occurring in equation (6), the logarithmic formula

$$\log \frac{f(\lambda_1)}{\lambda_1 F'(\lambda_1)} e^{\lambda_1 t} = \lambda_1 t + \log f(\lambda_1) - \log \lambda_1 - \log F'(\lambda_1) \quad (13)$$

is used. For the purpose of calculating these logarithms, it is convenient to express the complex numbers (λ_1 , $f(\lambda_1)$, etc.) as vectors of radius R and angle θ , writing, for example,

$$\lambda_1 = a + ib = R_1(\cos \theta_1 + i \sin \theta_1) = R_1 e^{i\theta_1} \quad (14)$$

by De Moivre's formula.

A complex term of equation (6) may then be written,

$$\begin{aligned} \frac{f(\lambda_1)}{\lambda_1 F'(\lambda_1)} e^{\lambda_1 t} &= \frac{R_2 e^{i\theta_2}}{R_1 e^{i\theta_1} R_3 e^{i\theta_3}} e^{\lambda_1 t} \\ &= \frac{R_2}{R_1 R_3} e^{\lambda_1 t + i(\theta_2 - \theta_1 - \theta_3)} \\ &= R_0 e^{\lambda_1 t + i\theta_0} \end{aligned} \quad (15)$$

Then

$$\log \frac{f(\lambda_1)}{\lambda_1 F'(\lambda_1)} e^{\lambda_1 t} = \lambda_1 t + \log R_0 + i\theta_0 \quad (16)$$

and the resultant logarithm may be plotted as a straight line $\lambda_1 t + \text{constant}$, which is then divided or extended to represent any division or extension of the time t over which the calculation is made. (See fig. 3.) The final vectors will represent the complex values of

$$\frac{f(\lambda_1)}{\lambda_1 F'(\lambda_1)} e^{\lambda_1 t}$$

and it is seen that the ordinates of the points of the line $\lambda_1 t + \text{constant}$ are the angles of these final vectors while the abscissas are the logarithms of their radii.

By a separation of the two components of the imaginary root $\lambda = a + ib$, the logarithmic formula may be reduced to

$$\begin{aligned} \log \frac{f(a+ib)}{(a+ib)F'(a+ib)} e^{(a+ib)t} &= (a+ib)t + \log R_0 + i\theta_0 \\ &= (\log R_0 + at) + i(\theta_0 + bt) \end{aligned} \quad (17)$$

The final formula, where $\lambda_1 = a + ib$, then becomes

$$\frac{f(\lambda_1)}{\lambda_1 F'(\lambda_1)} e^{\lambda_1 t} = R_0 e^{at} e^{i(\theta_0 + bt)} \quad (18)$$

or, by De Moivre's theorem,

$$\frac{f(\lambda)}{\lambda F'(\lambda)} e^{\lambda t} = R_0 e^{at} [\cos (bt + \theta_0) + i \sin (bt + \theta_0)] \quad (19)$$

The points thus plotted will lie on a logarithmic spiral (fig. 3); the deviation of this spiral from a circle

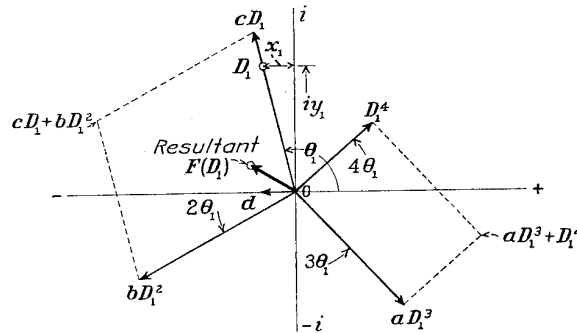

FIGURE 2.—Graphical method of locating values of $F(D)$ near zero, where $F(D) = D^4 + aD^3 + bD^2 + cD + d$. $D_1 = x_1 + iy_1 = R_1 e^{i\theta_1} = R_1(\cos \theta_1 + i \sin \theta_1)$

shows the influence of damping on the natural motion of the airplane.

The summation indicated in equation (6) calls for the plotting of such a logarithmic spiral for each of the complex roots. Since these roots always occur in conjugate pairs, the calculation may be carried out for one of such a pair and a spiral calculated for the second would be exactly conjugate to the first. Thus, it is only necessary to perform the foregoing calculations for one root of each pair, the summations indicated in the equations being carried out in effect by merely doubling the abscissas of the points of one of the conjugate spirals. If $\lambda_1 = a + ib$ and $\lambda_2 = a - ib$, this summation may be written:

$$\sum_{\lambda_1}^{\lambda_2} \frac{f(\lambda)}{\lambda F'(\lambda)} e^{\lambda t} = 2R_0 e^{at} \cos (bt + \theta_0) \quad (20)$$

The formulas for the integration of terms containing $\sin nt$ and $\cos nt$ may be put into a more convenient form for the graphical or logarithmic calculations, i. e.,

$$\frac{f(D)}{F(D)} Y_0 \sin nt = Y_0 \left[\text{imaginary coordinate of } \frac{f(in)}{F(in)} e^{int} + \sum_{\lambda} \frac{n}{\lambda^2 + n^2} \frac{f(\lambda)}{F'(\lambda)} e^{\lambda t} \right] \quad (21)$$

$$\frac{f(D)}{F(D)} Y_0 \cos nt = Y_0 \left[\text{real coordinate of } \frac{f(in)}{F(in)} e^{int} + \sum_{\lambda} \frac{\lambda}{\lambda^2 + n^2} \frac{f(\lambda)}{F'(\lambda)} e^{\lambda t} \right] \quad (22)$$

kinematic constraint, or prescribed acceleration, imposed by the control as to assume that the pilot uses the control in an arbitrary way. This assumption leads to the inversion of the integration problems heretofore considered, because the motion of the airplane is itself predetermined and the forces and moments (or, more properly, accelerations) required to be supplied by the controls are calculated by differentiation. The ability of various control devices to produce a given maneuver of the airplane may thus be compared and the degree of coordination required of the other controls may be studied.

The foregoing procedure is a particularly useful way of studying the lateral-control effectiveness in turns. Turn maneuvers, which usually begin and end in level

naturally follows by differentiating this equation. If the turn is to be "perfect," that is, with no sideslipping, the rate of yawing throughout must bear a definite relation to the angle of bank, namely,

$$r = \frac{g}{U_0} \sin \varphi \tag{28}$$

or, simply,

$$r = \frac{g}{U_0} \varphi \text{ if } \varphi \text{ is under } 30^\circ$$

Differentiating the expressions for p and r gives the accelerations in rolling and yawing and hence the

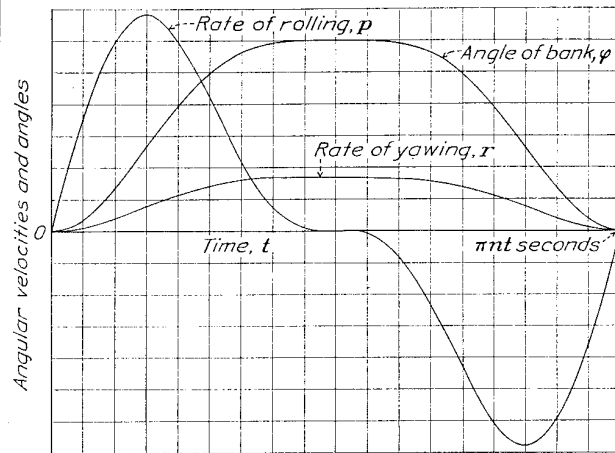

FIGURE 5.—Specifications for a turn maneuver in which the constraints are given by $\varphi = \frac{1}{2}A_1 + A_1 \cos nt + \frac{1}{2}A_1 \cos 2nt$; $p = \frac{d\varphi}{dt}$; $r = \frac{g}{U_0} \varphi$.

moments, which will arise from two sources: the reactions due to natural stability and the reactions produced by the displaced controls. The reactions arising from the motions are found by combining the known stability derivatives with the angular velocities p and r , obtained from the specification equations (27) and (28). The parts of the moments necessarily supplied by the controls are then obtained by deducting these from the total moments. In the case of the aileron control, secondary moments in yaw result from the application of rolling moment, which modify the amount of rudder control displacement necessary.

CONTROL AGAINST GUSTS OR ENGINE FAILURE

In order to deal with attempted control of a given disturbance it is important to consider that there is invariably a lag in the pilot's reaction in countering the motion. In these cases it is possible to assume that the disturbance arises instantly, or nearly so (whether persistent or not), and that the pilot's displacement of the corrective control takes place according to the law

$$\delta = \delta_0(1 - e^{-nt}) \tag{29}$$

(see fig. 4(B)) where δ_0 is the assumed maximum control deflection, which occurs more or less quickly as $-n$ is made large or small.

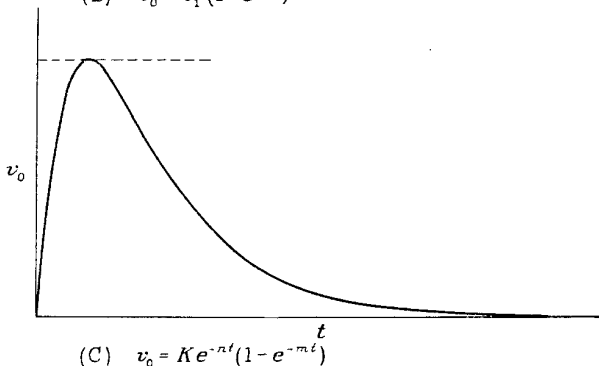
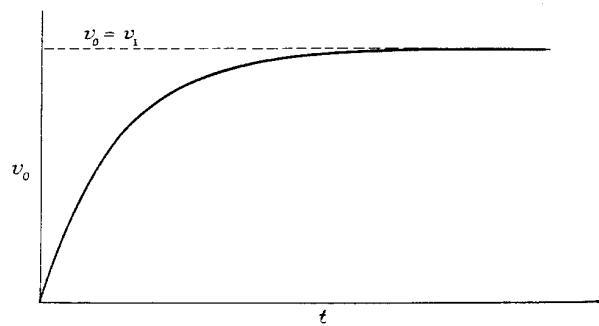
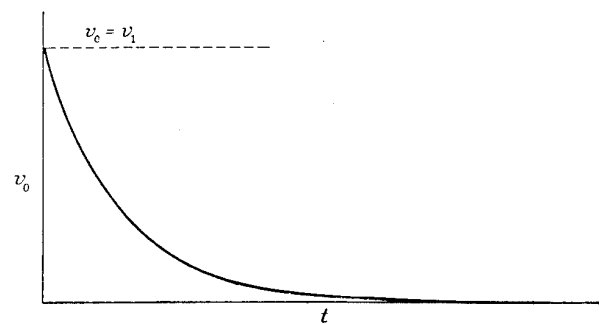

FIGURE 4.—Curves of different formulas for representing gusts.

flight, may be described by means of a few sine or cosine terms. For example, the angle of bank φ may be given by

$$\varphi = \text{constant} + A_1 \cos nt + A_2 \cos 2nt + \text{etc.} \tag{27}$$

(See fig. 5.) The rate of rolling at every instant

EXAMPLES SHOWING APPLICATION OF OPERATIONAL METHODS TO PROBLEMS OF AIRPLANE MOTION

The following examples illustrate the application of the various methods to specific problems of airplane motion. The airplane assumed in these calculations is a typical 2-passenger machine having the following characteristics:

CHARACTERISTICS OF TYPICAL AIRPLANE

Type: Monoplane; aspect ratio 6; rectangular, rounded tip, Clark Y wing; dihedral angle, 1°.

Dimensions:

Gross weight.....	1,600 lb.
Wing span.....	32 ft.
Wing area.....	171 sq. ft.
mk_x^2	1,216 slug-ft. ²
mk_z^2	1,700 slug-ft. ²

Stability derivatives:

U_0 (ft./sec.)	C_L	L_p	L_r	$U_0 L_v$	N_p	N_r	$U_0 N_r$
150	0.35	-5.44	1.11	-2.16	-0.207	-0.913	5.52
88.5	1.0	-3.23	1.88	-1.11	-.301	-.663	2.04
66	^a 1.8	-2.46	2.51	-1.66	-.310	-.977	1.46

^a Flaps down.

The calculated principal lateral-stability derivatives of this machine given with the other characteristics refer to motions of a set of axes fixed in the airplane but so inclined that the X axis points in the direction of the relative wind in straight flight at the lift coefficient specified. The axes, nevertheless, move with the machine during the small oscillations considered and hence depart slightly from instantaneous reference axes fixed in the wind direction.

ILLUSTRATION OF SOLUTION WITH CONSTANT DISTURBANCE TERM

Example I, Rolling motion produced by deflecting ailerons at low speed:

(a) Assume the machine to be in level steady flight at a speed of 88.5 feet per second ($C_L=1.0$) and that a rolling moment corresponding to $C_l=0.04$, with an adverse yawing moment $C_n=-0.01$, is applied suddenly at the time $t=0$. This condition corresponds approximately to a full deflection of ordinary ailerons at this speed.

(b) The equations of the motion in the three degrees of lateral freedom may be set up without including the expressions for the lateral air force, since this force is small and may be neglected in this case. The equations are:

$$\left. \begin{aligned} \frac{dv}{dt} &= g\phi - rU_0 \\ \frac{dp}{dt} &= vL_v + pL_p + rL_r + L_0 \\ \frac{dr}{dt} &= vN_v + pN_p + rN_r + N_0 \end{aligned} \right\} \quad (30)$$

The terms L_0 and N_0 represent the accelerations due to the constant control moments suddenly applied at $t=0$. They are

$$\begin{aligned} L_0 &= \frac{C_l q S b}{m k_x^2} \\ N_0 &= \frac{C_n q S b}{m k_z^2} \end{aligned} \quad (31)$$

The substitution of D for d/dt , and the rearrangement of the equations result in

$$\left. \begin{aligned} D^2 v - gp + DU_0 r &= 0 \\ -L_v v + (D - L_0)p - L_r r &= L_0 \\ -N_v v - N_p p + (D - N_r)r &= N_0 \end{aligned} \right\} \quad (32)$$

Since the rolling motion is desired, the equations will be solved for p . The algebraic solution is:

$$p = \frac{\begin{vmatrix} D^2 & 0 & DU_0 \\ -L_v & L_0 & -L_r \\ -N_v & N_0 & (D - N_r) \end{vmatrix}}{\begin{vmatrix} D^2 & -g & DU_0 \\ -L_v & (D - L_p) & -L_r \\ -N_v & -N_p & (D - N_r) \end{vmatrix}} \quad (33)$$

which is then reduced to the form required for expansion in equation (6),

$$p = \frac{f_1(D)}{F(D)} L_0 + \frac{f_2(D)}{F(D)} N_0 \quad (34)$$

The calculation of the various polynomials in D results in:

$$\left. \begin{aligned} f_1(D) &= D^3 - N_r D^2 + U_0 N_v D \\ f_2(D) &= L_r D^2 - U_0 L_v D \\ F(D) &= D^4 - (L_p + N_r) D^3 + (L_p N_r - L_r N_p + U_0 N_v) D^2 \\ &+ U_0 \left(L_v N_p - L_p N_v - \frac{g}{U_0} L_r \right) D + g(L_r N_r - L_r N_v) \end{aligned} \right\} \quad (35)$$

At the assumed speed of 88.5 feet per second ($C_L=1.0$), the constant rolling and yawing accelerations are

$$\begin{aligned} L_0 &= 1.68 \\ N_0 &= -0.301 \end{aligned} \quad (36)$$

Using these numerical values, combined with those given for the stability derivatives, the polynomials in D become

$$\left. \begin{aligned} f_1(D) &= D^3 + 0.663 D^2 + 2.04 D \\ f_2(D) &= 1.88 D^2 + 1.11 D \\ F(D) &= D^4 + 3.89 D^3 + 4.75 D^2 + 10.33 D - 1.13 \end{aligned} \right\} \quad (35a)$$

In order to perform the expansion of $\frac{f(D)}{F(D)}$ by Heaviside's theorem it is necessary to determine the roots of the complementary equation $F(D)=0$. When the

polynomial $F(D)$ is plotted as a function of a real variable (D), two real roots of this equation are found:

$$\left. \begin{aligned} \lambda_1 &= -3.41 \\ \lambda_2 &= 0.104 \end{aligned} \right\} \quad (37)$$

By the use of vector diagrams (see fig. 2) and the plotting of a map of the polynomial considered as a function of a complex variable ($D=x+iy$), the following root was found by interpolation:

$$\lambda_3 = 1.78 (\cos 1.73 + i \sin 1.73) \quad (38)$$

An additional complex root that is the conjugate of λ_3 is known to exist and completes the four roots of the fourth-degree equation,

$$\lambda_4 = 1.78 (\cos 1.73 - i \sin 1.73) \quad (39)$$

The next step is to set up the integration equation and perform the indicated operations. Since the applied control moments L_0 and N_0 are constants, form (6) will be used

$$p = \frac{f_1(D)}{F(D)}L_0 + \frac{f_2(D)}{F(D)}N_0 = L_0 \left[\frac{f_1(0)}{F(0)} + \sum_{\lambda} \frac{f_1(\lambda)}{\lambda F'(\lambda)} e^{\lambda t} \right] + N_0 \left[\frac{f_2(0)}{F(0)} + \sum_{\lambda} \frac{f_2(\lambda)}{\lambda F'(\lambda)} e^{\lambda t} \right] \quad (40)$$

The various terms to be substituted in this formula are found to be:

$$\left. \begin{aligned} \frac{f_1(0)}{F(0)}L_0 + \frac{f_2(0)}{F(0)}N_0 &= 0 \\ f_1(\lambda)L_0 + f_2(\lambda)N_0 &= 1.68\lambda^3 + 0.54\lambda^2 + 3.09\lambda \\ \lambda F'(\lambda) &= 4\lambda^4 + 11.67\lambda^3 + 9.49\lambda^2 + 10.33\lambda \end{aligned} \right\} \quad (41)$$

These terms are to be calculated for the four (real and complex) values of the roots. In the case of the real roots the calculation is made without resorting to graphical methods. For $\lambda_1 = -3.41$, the value

$$\frac{f_1(\lambda_1)L_0 + f_2(\lambda_1)N_0}{\lambda_1 F'(\lambda_1)} = -0.484 \text{ results,} \quad (42)$$

and for $\lambda_2 = 0.104$

$$\frac{f_1(\lambda_2)L_0 + f_2(\lambda_2)N_0}{\lambda_2 F'(\lambda_2)} = 0.277 \quad (43)$$

It will be convenient to perform graphical calculations to determine the other parts of the solution, corresponding to the complex terms. This result is accomplished by calculating the square, cube, and fourth power of the absolute length of λ_3 and by multiplying each of these values by the proper coefficients in the polynomials $f(D)$ and $F(D)$. By vector addition the value of the first polynomial was determined as

$$f_1(\lambda_3)L_0 + f_2(\lambda_3)N_0 = 3.99 (\cos 5.23 + i \sin 5.23) \quad (44)$$

and the second

$$\lambda_3 F'(\lambda_3) = 40.6 (\cos 5.60 + i \sin 5.60). \quad (45)$$

Since the quotient of these values is to be multiplied into $e^{\lambda_3 t}$ for a series of values of t it will be convenient to use the logarithm of this quotient, simply adding to it the various values of $\lambda_3 t$ for which the calculation is to be made. This logarithm is

$$\log \frac{f_1(\lambda_3)L_0 + f_2(\lambda_3)N_0}{\lambda_3 F'(\lambda_3)} = (\log 3.99 - \log 40.6) + i(5.23 - 5.60) = -2.32 - 0.38 i \quad (46)$$

The logarithm of the result naturally occurs in the form $x+iy$. Plotting this point on the paper and constructing from it a line parallel to λ_3 , we obtain the locus of

$$\log \frac{f_1(\lambda_3)L_0 + f_2(\lambda_3)N_0}{\lambda_3 F'(\lambda_3)} e^{\lambda_3 t}$$

for various values of t (see fig. 3). The angles of the final points are given by the ordinates of these logarithms and the absolute lengths by the antilogarithms of the abscissas. The final points are found to lie on a logarithmic spiral whose radius decreases with the time (time measured as angle) showing the damping of this component of the motion. The summation over the two conjugate roots λ_3 and λ_4 is accomplished without any further calculation by merely doubling the abscissas of the points plotted above, as has been pointed out. The values thus obtained are listed in the following table:

Table of values obtained from graphical construction

t (Seconds)	$\sum_{\lambda} \frac{f_1(\lambda)L_0 + f_2(\lambda)N_0}{\lambda F'(\lambda)} e^{\lambda t}$
	(For λ_3 and λ_4)
0	0.184
.2	.186
.4	.166
.6	.130
.8	.082
1.0	-.030
1.5	-.080
2.0	-.110

At the time $t=0$, $e^{\lambda t}$ will be unity so that the initial condition of zero rate of rolling should be given by the sum of its coefficients. The summation

$$-0.484 + 0.277 + 0.184 = -0.023$$

shows how nearly this condition is attained. Figure 6 shows the resultant rate of rolling and the components of the solution corresponding to each of the four roots, λ_n . In addition to the rolling curve obtained by the foregoing methods, other curves obtained by step-by-step integrations of the same equations of motion are given. In the calculation of these curves, steps of one-tenth and one-twentieth second were taken, which resulted in the differences shown.

ILLUSTRATION OF SOLUTION WITH VARIABLE DISTURBANCE TERMS

Example II, Sideslipping during 2-control turn maneuver:

(a) Assume the airplane to perform a specified banking maneuver by application of a variable rolling moment. If no yawing moments (from either rudder or

aileron) are applied, the natural stability of the airplane will cause it to turn in a direction appropriate to the direction banked. Such a turn is called a "2-control turn," inasmuch as only two (aileron and elevator) of the three available controls are used. Since there will not be a very perfect coordination between the banking and yawing, some sideslip will result. It is of interest to know the approximate amount of this

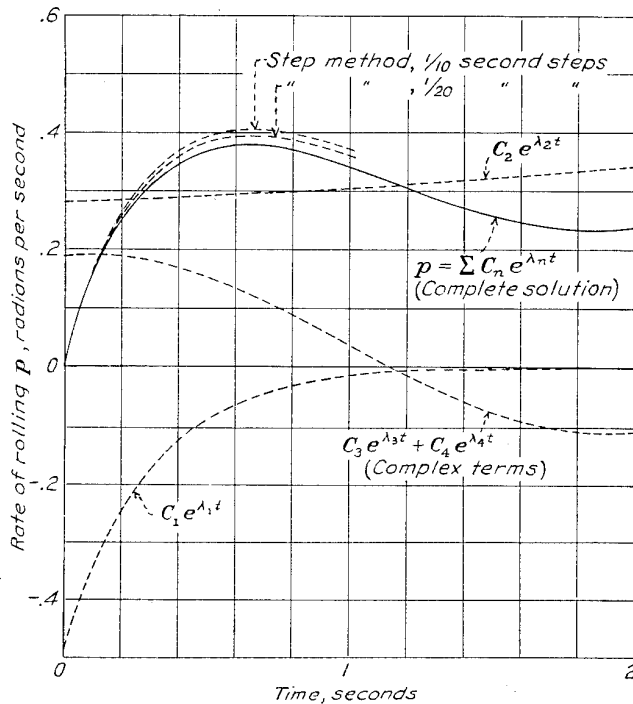

FIGURE 6.—Result of sample computation compared with step-by-step integrations; example I. Rolling motion following sudden deflection of ailerons. Typical 1,600-pound airplane. $C_1=1.0$; $C_2=0.04$; $C_3=-0.01$.

sideslip during such a turn in studying the practicability of 2-control operation.

(b) The first step in this problem is the determination of a suitable expression for the banking part of the maneuver. It was considered that the pilot would naturally conform his use of the control to the desired motion of the airplane rather than move the control in a predetermined way and accept whatever motion of the machine followed. Hence it seems more logical to specify the banking motion itself rather than to try to predetermine a law of application of rolling moment.

The airplane is thus assumed to be constrained in banking by the aileron control so as to follow a well-executed bank maneuver and recovery. The usual procedure in making a turn is to bank the machine up to a definite angle, holding this angle steadily for a short time while in the steady part of the turn, and then to recover to level flight on the completion of the desired angle of turn. A curve representing such a relation of bank angle against time may be represented by a series of only two cosine terms with a constant defining the

initial and terminal conditions of level flight, or zero bank angle. (See fig. 7.) For a fairly sharp turn with this small airplane the time required will be about 6 seconds if the maximum angle of bank is 30° . The specification decided on is:

$$\text{Bank angle, } \varphi = 0.327 - 0.262 [\cos t + \frac{1}{4} \cos 2t] \quad (47)$$

which reaches a steady value of 30° , and gives level flight at $t=0$ and $t=2\pi$ seconds. The rate of rolling is the rate of change of this angle of bank; or

$$p = \frac{d\varphi}{dt} = 0.262 \sin t + 0.131 \sin 2t \quad (48)$$

A constraint of the machine in one of its degrees of freedom having thus been specified, it is only necessary to consider the equations for free motion in the remaining two degrees. As before, the lateral motion will be assumed to be independent of the longitudinal. There remain only the sideslipping and yawing motions to be considered. Their equations are:

$$\left. \begin{aligned} \frac{dv}{dt} &= g\varphi - rU_0 \\ \frac{dr}{dt} &= vN_v + pN_p + rN_r \end{aligned} \right\} \quad (49)$$

Although the equations contain the rate of rolling and the angle of bank, these are to be considered as known

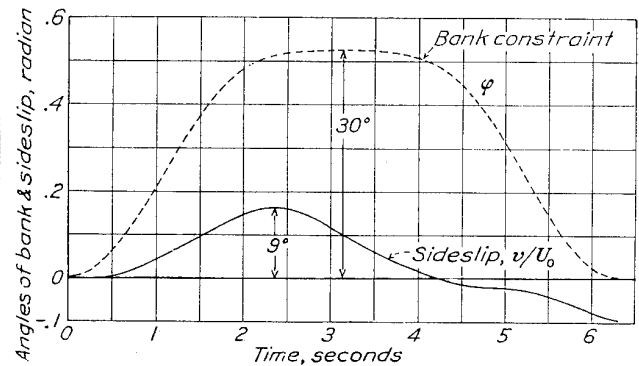

FIGURE 7.—Result of computation; example II. Sideslip during a 2-control turn maneuver.

from equations (29) and (30) and are, in fact, to be used as the disturbance terms. Calling

$$\left. \begin{aligned} Y_0 &= \frac{g}{U_0} \varphi \\ N_0 &= pN_p \end{aligned} \right\} \quad (50)$$

and rearranging the equations as in the other problems:

$$\left. \begin{aligned} D \frac{v}{U_0} + r &= Y_0 \\ -U_0 N_v \frac{v}{U_0} + (D - N_r) r &= N_0 \end{aligned} \right\} \quad (51)$$

Solving algebraically for v/U_0 :

$$\frac{v}{U_0} = \frac{\begin{vmatrix} Y_0 & 1 \\ N_0 & (D-N_r) \end{vmatrix}}{\begin{vmatrix} D & 1 \\ -U_0 N_v & (D-N_r) \end{vmatrix}} \quad (52)$$

or

$$\frac{v}{U_0} = \frac{f_1(D)}{F(D)} Y_0 + \frac{f_2(D)}{F(D)} N_0 \quad (52a)$$

where

$$\left. \begin{aligned} f_1(D) &= D - N_r \\ f_2(D) &= -1 \\ F(D) &= D^2 - N_r D + U_0 N_v \end{aligned} \right\} \quad (53)$$

If the airplane is to maintain its altitude while turning, the speed must be adjusted to give a higher lift than that at an equal lift coefficient in level flight. At an assumed lift coefficient of 1 the speed necessary to maintain altitude while turning at 30° bank is found to be 95 feet per second. Actually, if this speed is held throughout the specified maneuver, the longitudinal path will be accelerated somewhat; this condition will be neglected in the present problem. The necessary stability derivatives calculated for the new condition are:

$$\left. \begin{aligned} N_r &= -0.712 \\ U_0 N_v &= 2.40 \\ N_p &= -0.323 \end{aligned} \right\} \quad (54)$$

The "disturbance effects" Y_0 and N_0 are (see equations (46), (47), and (49))

$$\left. \begin{aligned} Y_0 &= 0.111 - 0.0888 \cos t - 0.0222 \cos 2t \\ N_0 &= -0.0846 \sin t - 0.0423 \sin 2t \end{aligned} \right\} \quad (55)$$

and, finally,

$$\begin{aligned} \frac{v}{U_0} &= 0.111 \frac{f_1(D)}{F(D)} - 0.0888 \frac{f_1(D)}{F(D)} \cos t \\ &\quad - 0.0222 \frac{f_1(D)}{F(D)} \cos 2t - 0.0846 \frac{f_2(D)}{F(D)} \sin t \\ &\quad - 0.0423 \frac{f_2(D)}{F(D)} \sin 2t \end{aligned} \quad (56)$$

For the expansion of these terms in the integration equations (6), (8), and (9), it is necessary to know the roots of $F(D) = 0$. These are

$$\left. \begin{aligned} \lambda &= \frac{N_r \pm \sqrt{N_r^2 - 4U_0 N_v}}{2} \\ \lambda &= -0.356 \pm 1.51i \end{aligned} \right\} \quad (57)$$

Since both these roots are complex, the operations indicated in the integration equations were performed graphically in the manner previously shown.

The results of these calculations are shown in figure 7. The fact that the error in meeting the zero sideslip condition at the start of the maneuver was very small (even though the graphical construction of several terms was required) gives an indication of the accuracy of the calculation.

LANGLEY MEMORIAL AERONAUTICAL LABORATORY,
NATIONAL ADVISORY COMMITTEE FOR AERONAUTICS,
LANGLEY FIELD, VA., February 19, 1936.

APPENDIX

EVALUATION OF ELEMENTARY OPERATORS

A simple differential equation may be used to illustrate briefly Heaviside's method of evaluating more elementary operational forms. Consider the case of an airplane executing pure rolling motion under the influence of a suddenly applied rolling moment of magnitude $mk_x^2 L_0$, which produces the impulsive acceleration L_0 in roll. The equation of motion may be written:

$$\frac{dp}{dt} = pL_p + L_0 \quad (58)$$

in which both p and L_0 are supposed to have the value zero at the time $t=0$.

The solution of this equation as ordinarily found will consist of two parts, one of which is a solution of

$$\frac{dp}{dt} - pL_p = 0 \quad (59)$$

the "complementary equation." In effect, Heaviside wrote both equations, (58) and (59), as one by introducing a discontinuous function of t into (58). Thus, (substituting the usual D)

$$Dp - L_p p = 1(t)L_0 \quad (60)$$

where the symbol $1(t)$ is termed the "unit function," and is supposed to have the value zero until the time $t=0$ and to take the value 1 thereafter. The algebraic solution of (60) is then written

$$p = \frac{1}{D - L_p} 1(t)L_0 \quad (60a)$$

and it is required to evaluate the form

$$\frac{1}{D - L_p} 1(t)$$

The procedure is to expand the fraction by the binomial theorem in ascending powers of L_p , thus,

$$(D - L_p)^{-1} = D^{-1} + D^{-2}L_p + D^{-3}L_p^2 + \dots + \text{etc.} \quad (61)$$

Since

$$D^{-1}1(t) = \int 1(t)dt = 1(t)t$$

$$D^{-2}1(t) = \iint 1(t)dt dt = 1(t)\frac{t^2}{2!}; \text{ etc.,} \quad (62)$$

performing the indicated integrations results in

$$(D - L_p)^{-1}1(t) = 1(t)\left(t + \frac{L_p t^2}{2!} + \frac{L_p^2 t^3}{3!} + \dots + \text{etc.}\right) \quad (63)$$

If this series is multiplied throughout by L_p it becomes identically the series for $e^{L_p t}$ except for the term 1, that is

$$[L_p(D - L_p)^{-1} + 1]1(t) = 1(t)e^{L_p t} \quad (64)$$

or

$$(D - L_p)^{-1}1(t) = \frac{1(t)}{L_p}(e^{L_p t} - 1) \quad (65)$$

The final solution of the original equation (1) follows as

$$p = 1(t)\frac{L_0}{L_p}(e^{L_p t} - 1) \quad (66)$$

Such forms as the left side of equation (60), involving the symbol D , are termed "operators." Equations (6) to (9) of the text are to be considered as evaluations of the more complex operators $f(D)/F(D)$ along the above-indicated lines. The evaluation of a number of such forms is given in reference 5.

Equation (6) of the text is a shorthand method of arriving at the foregoing solution. For the present problem this formula is:

$$p = \frac{f(D)}{F(D)}1(t)L_0 = 1(t)\left[\frac{f(0)}{F(0)}L_0 + \sum_{\lambda} \frac{f(\lambda)L_0}{\lambda F'(\lambda)} e^{\lambda t}\right] \quad (67)$$

and the various terms are:

$$\left. \begin{aligned} f(D) &= 1 \\ F(D) &= D - L_p \\ f(0) &= 1 \\ F(0) &= -L_p \\ \lambda &= L_p \\ f(\lambda) &= 1 \\ F'(\lambda) &= 1 \end{aligned} \right\} \quad (68)$$

The substitution of these terms in (67) results in

$$p = 1(t)\frac{L_0}{L_p}(e^{L_p t} - 1) \quad (69)$$

as before.

REFERENCES

1. Wilson, Edwin Bidwell: Theory of an Aeroplane Encountering Gusts. T. R. No. 1, Part 2, 1915; II, T. R. No. 21, 1917; and III, T. R. No. 27, N. A. C. A., 1918.
2. Bryant, L. W., and Williams, D. H.: The Application of the Method of Operators to the Calculation of the Disturbed Motion of an Aeroplane. R. & M. No. 1346, British A. R. C., 1931.
3. Routh, E. J.: Advanced Rigid Dynamics, vol. II. The MacMillan Company, 1905.
4. Goursat, Edouard: Functions of a Complex Variable. Translated by E. R. Hedrick and Otto Dunkel, Ginn & Co., 1916.
5. Bush, V.: Operational Circuit Analysis. John Wiley and Sons, Inc., 1929.

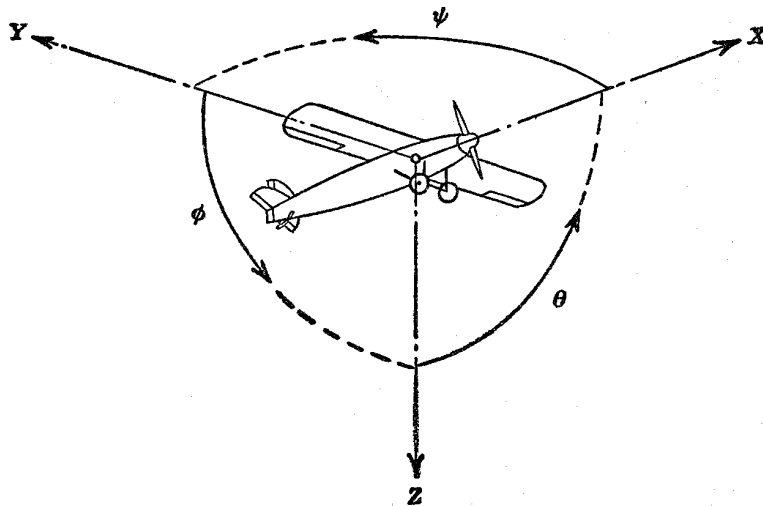

Positive directions of axes and angles (forces and moments) are shown by arrows

Axis		Force (parallel to axis) symbol	Moment about axis			Angle		Velocities	
Designation	Sym- bol		Designation	Sym- bol	Positive direction	Designa- tion	Sym- bol	Linear (comp- nent along axis)	Angular
Longitudinal	X	X	Rolling	L	Y → Z	Roll	φ	u	p
Lateral	Y	Y	Pitching	M	Z → X	Pitch	θ	v	q
Normal	Z	Z	Yawing	N	X → Y	Yaw	ψ	w	r

Absolute coefficients of moment

$$C_l = \frac{L}{qbS}$$

(rolling)

$$C_m = \frac{M}{qcS}$$

(pitching)

$$C_n = \frac{N}{qbS}$$

(yawing)

Angle of set of control surface (relative to neutral position), δ . (Indicate surface by proper subscript.)

4. PROPELLER SYMBOLS

D , Diameter

p , Geometric pitch

p/D , Pitch ratio

V' , Inflow velocity

V_{∞} , Slipstream velocity

T , Thrust, absolute coefficient $C_T = \frac{T}{\rho n^2 D^4}$

Q , Torque, absolute coefficient $C_Q = \frac{Q}{\rho n^2 D^5}$

P , Power, absolute coefficient $C_P = \frac{P}{\rho n^3 D^5}$

C_s , Speed-power coefficient = $\sqrt[5]{\frac{\rho V^5}{P n^2}}$

η , Efficiency

n , Revolutions per second, r.p.s.

Φ , Effective helix angle = $\tan^{-1} \left(\frac{V}{2\pi r n} \right)$

5. NUMERICAL RELATIONS

1 hp. = 76.04 kg-m/s = 550 ft-lb./sec.

1 metric horsepower = 1.0132 hp.

1 m.p.h. = 0.4470 m.p.s.

1 m.p.s. = 2.2369 m.p.h.

1 lb. = 0.4536 kg.

1 kg = 2.2046 lb.

1 mi. = 1,609.35 m = 5,280 ft.

1 m = 3.2808 ft.