

# Oil Exchange Between Ball Bearings and Cotton-Phenolic Ball-Bearing Retainers

15 September 1994

Prepared by

P. A. BERTRAND, D. J. CARRÉ, and R. BAUER  
Mechanics and Materials Technology Center  
Technology Operations

Prepared for

SPACE AND MISSILE SYSTEMS CENTER  
AIR FORCE MATERIEL COMMAND  
2430 E. El Segundo Boulevard  
Los Angeles Air Force Base, CA 90245



19950828 008

Engineering and Technology Group

APPROVED FOR PUBLIC RELEASE;  
DISTRIBUTION UNLIMITED

DTIC QUALITY INSPECTED 5

This report was submitted by The Aerospace Corporation, El Segundo, CA 90245-4691, under Contract No. F04701-93-C-0094 with the Space and Missile Systems Center, 2430 E. El Segundo Blvd., Los Angeles Air Force Base, CA 90245. It was reviewed and approved for The Aerospace Corporation by S. Feuerstein, Principal Director, Mechanics and Materials Technology Center.

This report has been reviewed by the Public Affairs Office (PAS) and is releasable to the National Technical Information Service (NTIS). At NTIS, it will be available to the general public, including foreign nationals.

This technical report has been reviewed and is approved for publication. Publication of this report does not constitute Air Force approval of the report's findings or conclusions. It is published only for the exchange and stimulation of ideas.

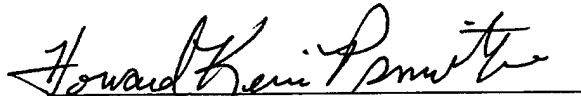
  
K. Psmithe, Capt. USAF  
SMC/CI

**REPORT DOCUMENTATION PAGE**Form Approved  
OMB No. 0704-0188

Public reporting burden for this collection of information is estimated to average 1 hour per response, including the time for reviewing instructions, searching existing data sources, gathering and maintaining the data needed, and completing and reviewing the collection of information. Send comments regarding this burden estimate or any other aspect of this collection of information, including suggestions for reducing this burden to Washington Headquarters Services, Directorate for Information Operations and Reports, 1215 Jefferson Davis Highway, Suite 1204, Arlington, VA 22202-4302, and to the Office of Management and Budget, Paperwork Reduction Project (0704-0188), Washington, DC 20503.

1. AGENCY USE ONLY (Leave blank)		2. REPORT DATE 15 September 1994	3. REPORT TYPE AND DATES COVERED	
4. TITLE AND SUBTITLE Oil Exchange Between Ball Bearings and Cotton-Phenolic Ball-Bearing Retainers			5. FUNDING NUMBERS F04701-93-C-0094	
6. AUTHOR(S) Bertrand, P. A.; Carré, D. J.; and Bauer, R.				
7. PERFORMING ORGANIZATION NAME(S) AND ADDRESS(ES) The Aerospace Corporation Technology Operations El Segundo, CA 90245-4691			8. PERFORMING ORGANIZATION REPORT NUMBER TR-94(4935)-4	
9. SPONSORING/MONITORING AGENCY NAME(S) AND ADDRESS(ES) Space and Missile Systems Center Air Force Materiel Command 2430 E. El Segundo Boulevard Los Angeles Air Force Base, CA 90245			10. SPONSORING/MONITORING AGENCY REPORT NUMBER SMC-TR-95-27	
11. SUPPLEMENTARY NOTES				
12a. DISTRIBUTION/AVAILABILITY STATEMENT Approved for public release; distribution unlimited			12b. DISTRIBUTION CODE	
13. ABSTRACT (Maximum 200 words)  Experiments have been performed that determine for the first time the transfer of oil between cotton-phenolic ball-bearing retainers and operating ball bearings. A full retainer exchanges oil with the metal parts of the bearing, probably by diffusional mixing. There is no net delivery of oil from the retainer to the metal parts of the bearing. A partially filled retainer (such as one that has been incompletely impregnated) absorbs oil from the bearing even during operation, thus drying the bearing. A fully-impregnated retainer does not deliver any significant amount of additional oil to the metal parts of a poorly lubricated bearing. The retainer will not prevent lubricant degradation and premature bearing failure under the conditions of these experiments.				
14. SUBJECT TERMS Lubrication, Cotton-Phenolic, Ball-bearings			15. NUMBER OF PAGES 25	
			16. PRICE CODE	
17. SECURITY CLASSIFICATION OF REPORT UNCLASSIFIED	18. SECURITY CLASSIFICATION OF THIS PAGE UNCLASSIFIED	19. SECURITY CLASSIFICATION OF ABSTRACT UNCLASSIFIED	20. LIMITATION OF ABSTRACT	

# Preface

The authors thank G. A. To for performing the infrared analyses. Support for the work was provided under Contract No. F04701-93-C-0094 with the Air Force Space and Missile Systems Center, 2430 E. El Segundo Blvd., Los Angeles Air Force Base, CA 90245.

Accession For	
NTIS GRA&I	<input checked="" type="checkbox"/>
DTIC TAB	<input type="checkbox"/>
Unannounced	<input type="checkbox"/>
Justification	
By _____	
Distribution _____	
Availability Codes	
Dist	Avail and/or Special
A-1	

## Contents

1. Introduction.....	1
2. Experimental.....	3
2.1 Oils and Oil Impregnation .....	3
2.2 IR Method and Calibration .....	5
2.3 Experimental Procedure .....	7
3. Results and Discussion.....	11
3.1 Full Retainers/Well-Lubricated Bearings.....	11
3.2 Partially Filled Retainers/Well-Lubricated Bearings.....	16
3.3 Full Retainers/Poorly Lubricated Bearings.....	20
4. Conclusions.....	23
References.....	25

## Figures

1. Oil absorption into 106 retainers.....	4
2. Infrared spectra for several calibration standards.....	6
3. IR calibration curve .....	7
4. Bearing test apparatus.....	8
5. Infrared spectra for heptane extract of retainers from static oil bath tests.....	13
6. Oil exchange between fully impregnated retainers and static oil bath .....	14
7. Oil exchange between fully impregnated retainers and oil in operating bearing .....	14
8. Oil exchange between fully impregnated retainers and oil in operating bearing .....	15
9. Oil exchange between partially impregnated retainers and static oil bath.....	18
10. Oil exchange between partially impregnated retainers and oil in operating bearing.....	19

## Tables

1. Full Retainer Oil Weights. (Tests with Well-Lubricated Bearings or Oil Baths) .....	11
2. Oil Composition After Tests. (Retainer Originally Full, Well-Lubricated Bearings) .....	15
3. Partially Filled Retainer Oil Weights. (Tests with Well-Lubricated Bearings or Oil Baths).....	17
4. Oil Composition After Test. (Retainer Originally Partially Full, Well-Lubricated Bearings) .....	18
5. Retainer Oil Weights. (Tests with Poorly Lubricated Bearings) .....	20
6. Oil Composition After Test. (Retainer Originally Full, Poorly Lubricated Bearings) .....	20

## 1. Introduction

Liquid lubricated ball bearings are used in many moving mechanical assemblies in spacecraft. Some specific applications are momentum- or reaction-wheel spin bearings, sensor support and scan bearings, and harmonic-drive bearings. Most of these systems are required to provide 5 to 7 years of on-orbit life with only the lubricant with which they are supplied at assembly. This requirement is one of the driving factors in the choice of lubricant (low vapor pressure to reduce evaporative losses), sealing strategies, and the use of porous ball retainers (to supply additional oil).

Cotton phenolic material is often used in ball retainers (also called "cages" or "separators"). The material is manufactured as tubes by winding cotton cloth containing resin precursors on a mandrel, then curing at high temperatures. It is structurally anisotropic—the threads run in two perpendicular directions. One set of threads runs the length of the tube, the other runs in a spiral fashion around the tube. The material is porous—there are capillary-like voids associated with the threads, and, in some cases, there are voids in the phenolic resin matrix also.

In general, cotton-phenolic retainers are filled with oil using a procedure called vacuum impregnation. In this process, the retainer is held above a container of warm oil in a chamber that is then evacuated. The retainer is immersed into the oil and allowed to soak for a period of time, varying from a few hours to a few days. A logical concern is that an incompletely impregnated retainer will continue to absorb oil from the bearing metal parts until the retainer is full, leading to an oil-deficient bearing surface. Another concern is whether even fully impregnated cotton-phenolic retainers deliver oil to bearings. Oil circulation has been observed for sintered nylon retainers,<sup>1</sup> but this material is much more porous than cotton-phenolic and has a three-dimensional network of pores instead of the laminar structure of cotton-phenolic.

In previous work,<sup>2</sup> we determined the mechanism by which oil enters cotton-phenolic material. The absorption is a two-step process in which the first step is filling the capillaries associated with the cotton threads. This step proceeds fairly rapidly and depends on the geometry of the piece of cotton-phenolic, which determines the lengths of the capillaries. Some of the wedge-shaped samples used in the previous work required 16 days for capillary filling; typical ball-bearing retainers complete this step in seven to ten days. The second step of oil absorption can be modeled by diffusion of oil from the capillaries into the bulk phenolic resin. This proceeds very slowly, perhaps taking over a year before completion. We determined a diffusion coefficient for this step of  $3 \times 10^{-12}$  cm<sup>2</sup>/s, similar to that of other large molecules into polymers. Another important result of the previous work was determination that the absorption of oil is not merely a surface property—the entire piece of material fills with oil.

However, even when porous cotton-phenolic separators, impregnated with oil, are used in satellite bearing systems, anomalous bearing behavior traceable to poor lubricant supply can be found.<sup>3</sup> One example is the failure in test of a prototype control moment gyroscope. The grease with which it had been lubricated was depleted in oil by a non-evaporative process, perhaps creep or absorption into the cotton-phenolic separators.<sup>4</sup> In this case, the cotton-phenolic separator was not supplying sufficient oil for trouble-free operation. Lack of oil at the ball-retainer interface

can cause retainer instability, leading to increased torque and torque noise and eventual failure of the bearing.<sup>5,6</sup> There is evidence that a constant supply, or even an occasional resupply, of oil to the critical interfaces will eliminate the instability and prolong life.<sup>7</sup>

In another example,<sup>8</sup> the torque of liquid-lubricated instrument bearings on a scanning sensor mechanism increased on orbit and also in test. The metal parts of the system had been treated with tricresyl phosphate (an antiwear additive), and the cotton-phenolic cages had been impregnated with a perfluoropolyalkylether oil. No additional oil was supplied to the bearing. When the test unit was analyzed, no transfer of oil from the cage to the metal parts was found.

The objectives of the experiments reported here were to determine whether oil from a running bearing can be absorbed by its cotton-phenolic separator, and whether oil from inside the separator can exit to provide lubricant to a running bearing. Two spectroscopically distinguishable oils were used in the bearings: one on the metal parts, and the other in the retainer. After each bearing was operated for a specific time, it was disassembled, and the oil was analyzed. If oil left the retainer, it would be detected in the oil rinsed from the parts; if oil were absorbed by the retainer, it would be detected in the oil extracted from the retainer. The retainers were also weighed at certain points in the procedure to determine net absorption or delivery of oil. In this way, we can determine whether cotton-phenolic ball separators act as oil sources or sinks during ball bearing operation.

## 2. Experimental

The tests were conducted using 30-mm bore, 440C stainless-steel angular contact bearings. The metal parts were not pretreated with phosphate esters, as is sometimes done to increase their wear resistance.

### 2.1 Oils and Oil Impregnation

Two oils that are distinguishable by infrared (IR) spectroscopy were used in these experiments: a poly- $\alpha$ -olefin (PAO) oil and a polyol ester (POE) oil. The two oils have the following IR spectral characteristics: the PAO is a hydrocarbon, with typical hydrocarbon absorption bands including C-H absorption bands at about  $2920\text{ cm}^{-1}$ , while the POE contains the carbonyl (C = O) functional group with an absorption band at about  $1740\text{ cm}^{-1}$  as well as the typical hydrocarbon absorption bands. The oils chosen for these experiments have the same viscosity, 57 centistokes at  $38^\circ\text{C}$ , and vapor pressures less than  $1 \times 10^{-4}\text{ Pa}$  ( $1 \times 10^{-6}\text{ torr}$ ) at room temperature. The oils each contained antiwear additives: the POE contained 1% tricresyl phosphate, and the PAO contained 1% of a synthetic phosphate ester mixture. The additives are in the same chemical family and are compatible.

In each experiment, one oil was impregnated into the retainer, while the other was used on the metal bearing parts. To eliminate any possible effects on the transfer process due to the different chemical natures of the two lubricants, half the experiments had POE impregnated into the retainer and PAO on the metal parts. In the remaining experiments, the oils were switched.

The retainers were cleaned by Soxhlet extraction in heptane overnight. They were then baked at  $100^\circ\text{C}$  in a vacuum oven at reduced pressure for three days, cooled, removed from the vacuum oven, and weighed. They were impregnated with oil by submersion in a room-temperature bath of the appropriate oil. The time the retainers spent in air was minimized because absorption of water from the air into the retainers interferes with oil absorption.<sup>2,9</sup> The oil baths were kept in desiccators using  $\text{CaSO}_4$  drying agent. The retainers were removed from the baths, centrifuged to remove excess surface oil, and weighed to determine the amount of oil impregnated into them. Initially, the retainers were removed from their baths and weighed every day to determine the oil absorption kinetics for retainers of this size.

Figure 1 shows the absorption kinetics for these retainers in the PAO and POE oils. They are similar to those we have found before.<sup>2</sup> For the retainers, the initial fast-absorption step is over before seven days have passed; to produce "full" retainers, we allowed a 7-day soak following our recommended procedures. To obtain partially filled retainers, we soaked dry retainers for about 15 min, which led to retainers filled to about 60% of their impregnation capacity (based on capillary fill).

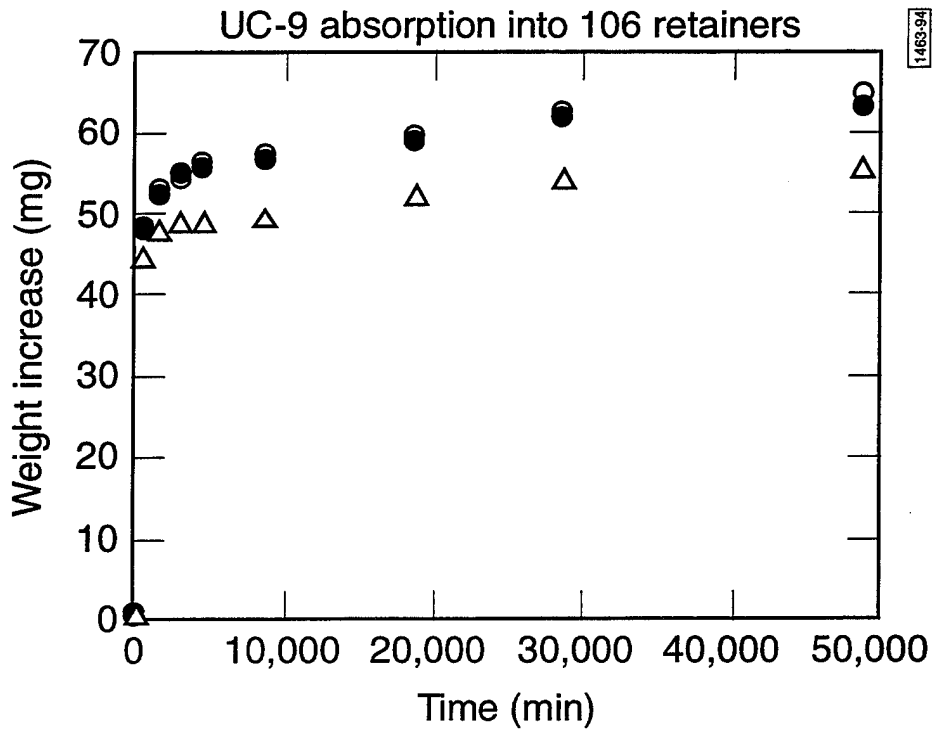
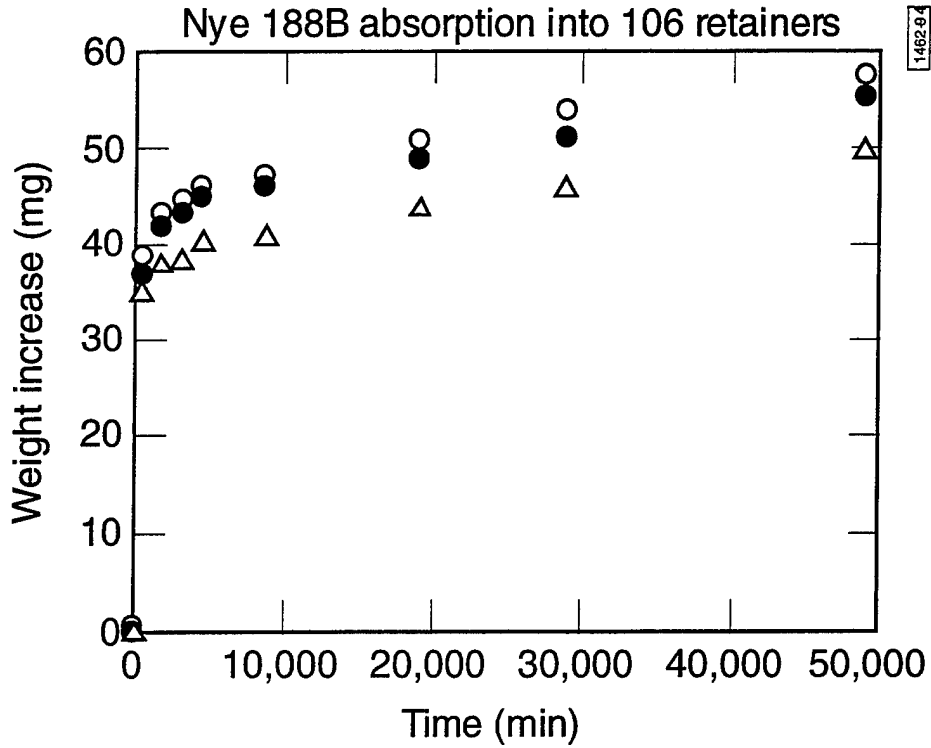

Figure 1. Oil absorption into 106 retainers. Each symbol represents a different retainer. 7 days  $\approx$  10,000 min. (a) Nye 188B, the PAO oil. (b) UC-9, the POE oil.

## 2.2 IR Method and Calibration

IR spectroscopy was used to determine the ratio of POE to PAO oil. Since small quantities of oil were involved (generally less than 60 mg), attenuated total reflectance (ATR) in the absorbance mode was used. In this method, a solution of the sample in a volatile solvent (heptane) was placed on the surface of an ATR plate. After evaporation of the solvent, the plate was subjected to IR analysis in the internal reflection mode. The fact that many reflections are possible increases the signal due to the very small sample. However, with the ATR technique (unlike transmission IR), the relative intensities of the peaks depend on the thickness of the sample layer on the plate surface as well as the concentration of species within the layer. It is very important to have the same sample thickness in all the samples and in the calibration standards.

The calibration standards were a series of known solutions of POE and PAO in heptane in which the ratio of the components was varied. Spectra were collected for increasing dilutions of the oils in heptane to determine a working range in which the variation of peak intensities due to sample thickness was not too great. Three different sets of diluted standards were used, and thus three different sample thicknesses were obtained on the plate: about  $1 \times 10^{-7}$ ,  $1 \times 10^{-8}$ , and  $1 \times 10^{-9}$  L of oil on the plate. Figure 2 shows spectra for solutions of 100% PAO, 90% PAO + 10% POE, 10% PAO + 90% POE, and 100% POE in heptane, for the case of about  $1 \times 10^{-8}$  L of oil on the plate. We measured the peak intensities of the  $1740 \text{ cm}^{-1}$  (ester) and  $2920 \text{ cm}^{-1}$  (ester + hydrocarbon) peaks for each spectrum and calculated their ratio. Figure 3 shows the value of this ratio, R, as a function of solution composition for the three dilution sets. All the results except those of the thickest films (the most concentrated solutions) fall on the same curve. We used this curve for our calibration since it was less sensitive to sample thickness variation (variation of the concentration of oil in heptane). Each sample from an experiment was diluted until the absorbance of the  $1740 \text{ cm}^{-1}$  peak was between 0.01 and 1, and the absorbance of the  $2920 \text{ cm}^{-1}$  peak was between 0.02 and 0.08. This procedure ensured that the oil concentration in heptane, and thus the oil thickness on the ATR plate, was sufficiently similar to the calibration standards that the calibration curve would be applicable.

The calibration curve is very flat for percentages of ester less than 20. This means that there is very little accuracy in determining the composition of solutions with such small amounts of POE oil, and any results that are less than 20% POE should be viewed as "almost no POE." In addition, there is a small amount of an ester contaminant in the solvent used in these experiments. When the relatively large amounts of solvent (50 to 600 ml of solvent, and about 50  $\mu\text{l}$  of oil) are evaporated, this ester contaminant remains and is detected in the IR analysis. Several tests were performed to estimate the amount of ester contaminant in the heptane washes, in which PAO was used in both the retainer and on the metal parts. The amount of ester compared to the PAO amount detected by IR was about 10% in the retainer extracts and 15% or less in the metal part washes, depending on whether the parts were well lubricated or poorly lubricated. This percentage of ester contaminant is <20%; therefore, we considered it to be in the "almost no POE" range and not to affect the results and conclusions.

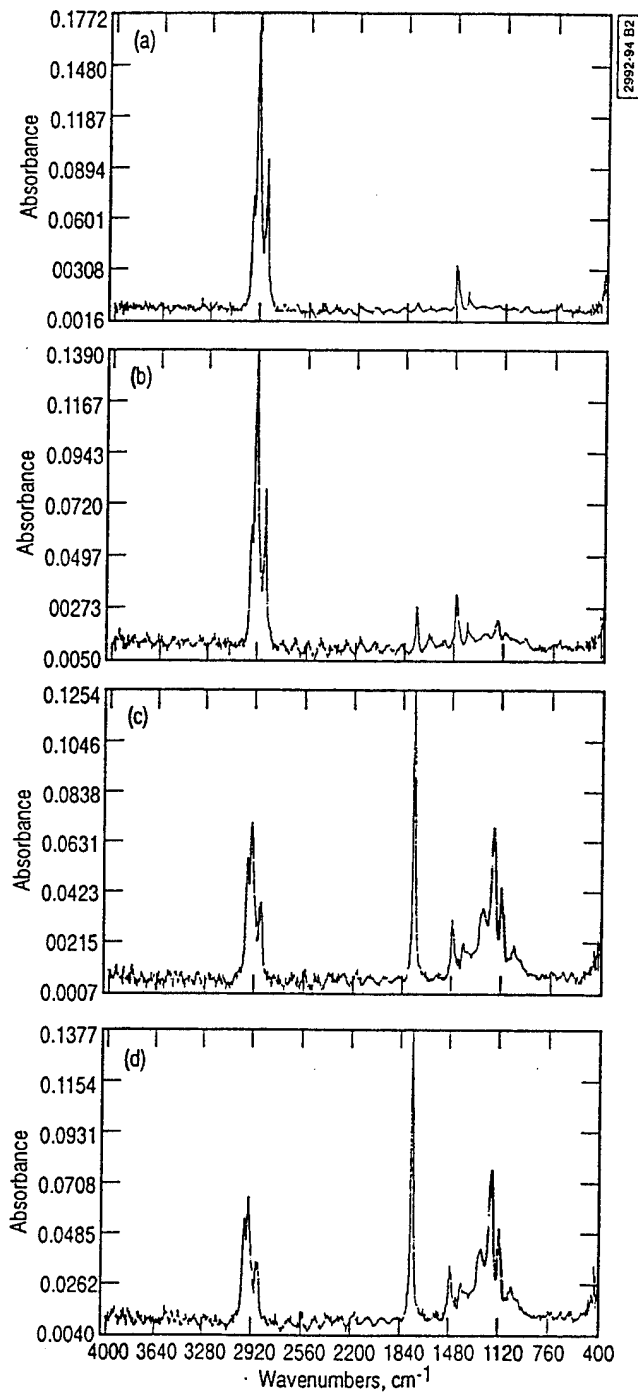

Figure 2. Infrared spectra for several calibration standards. The calibration procedure requires the ratio of peak intensities of the ester peak ( $1740 \text{ cm}^{-1}$ ) and the hydrocarbon peak ( $2920 \text{ cm}^{-1}$ ). All spectra are from solutions that placed about  $1 \times 10^{-8}$  L of oil on the ATR plate. (a) 100% PAO. (b) 90% PAO + 10% POE. (c) 10% PAO + 90% POE. (d) 100% POE.

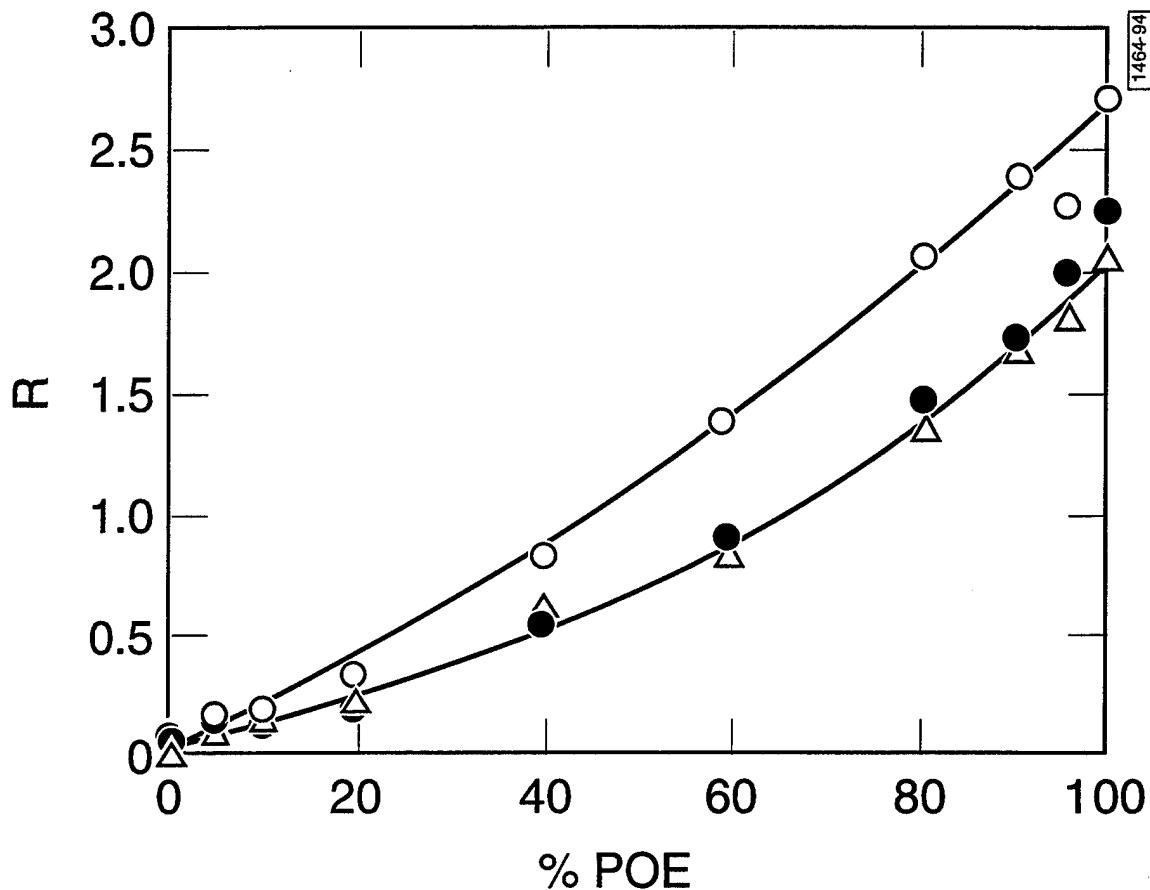

Figure 3. IR calibration curve. Each symbol represents a different concentration of oil in heptane:  $\circ$  corresponds to about  $1 \times 10^{-7}$  L of oil on the plate;  $\bullet$  corresponds to about  $1 \times 10^{-8}$  L of oil; and  $\Delta$  corresponds to about  $1 \times 10^{-9}$  L of oil.  $R$  is the ratio of peak intensities of the  $1740 \text{ cm}^{-1}$  and  $2920 \text{ cm}^{-1}$  absorbances.

### 2.3 Experimental Procedure

Four types of experiments were performed. In one type, fully impregnated retainers and well-lubricated bearings were used (tests T-1 through T-4 and T-17 through T-22). In another type, partially impregnated retainers and well-lubricated bearings were used (tests T-5 through T-16). In a third type, fully impregnated retainers and poorly lubricated metal parts were used (tests T-23 through T-38). In the fourth type, some retainers (both fully and partially impregnated) were stored in oil baths (tests B-1 through B-22).

The separators were cleaned and impregnated according to the procedure described above. Some were placed in room-temperature baths of the oil with which they were not impregnated. The baths were stored in desiccators with  $\text{CaSO}_4$  drying agent to minimize water absorption. These tests are referred to below as "static tests." Other separators were assembled into bearings.

To replace the original retainer in a bearing with the fully or partially impregnated retainer requires that the bearing be disassembled. Bearing disassembly is accomplished by heating the outer race to  $\sim 200^{\circ}\text{C}$  for  $\sim 45$  seconds in a special fixture in a dry-nitrogen atmosphere. Heating the outer race increases the clearance between the outer and inner races so that only a small amount of force need be applied to the inner race to cause the bearing components to separate. To reassemble the bearing (with the impregnated cage), the outer race is again heated and "snapped" into place with the other components.

To produce well-lubricated bearings, oil was applied to each bearing ball (there is a total of 14 balls) after assembly. We estimated that the sum of oil added in this manner was  $30 \pm 15$  mg by weighing several sets of similar drops added to a previously weighed dish. To produce poorly lubricated bearings, the metal parts (inner and outer rings and balls) were dipped in a solution of the oil in heptane. The heptane was allowed to evaporate before assembly. We determined that a 4% v/v solution would coat the parts with an oil layer approximately  $3 \mu\text{m}$  thick. This is about the thickness of the oil layer expected in many lightly lubricated spacecraft moving mechanical assemblies<sup>10</sup> (2 to  $5 \mu\text{m}$ ) and is approximately 10 mg of oil on the balls and in the raceways.

The Bearing Test Apparatus (BTA), shown in Figure 4, was used to test the bearings containing the impregnated retainers at a rotational speed of  $3000 \pm 200$  rpm. These are referred to below as

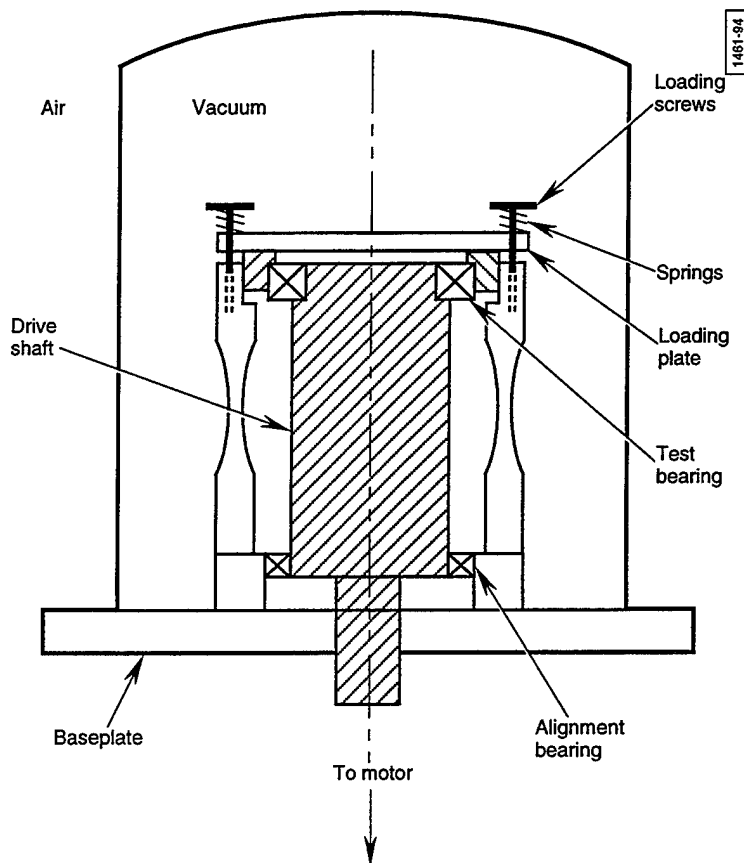

Figure 4. Bearing test apparatus.

"running tests." The test bearing was loaded to ~134 N (~30 lb.) (0.45 GPa mean Hertzian stress) via the loading screws, springs, and loading plate. All the tests were run in vacuum, with the pressure  $< 4 \times 10^{-5}$  Pa ( $3 \times 10^{-7}$  torr). The temperature of the bearings was not monitored. After a predetermined number of revolutions, the motor was stopped and the bearing was allowed to cool to room temperature in vacuum before removal from the BTA and disassembly.

In some experiments, the bearing was assembled, turned several times by hand, then disassembled. This procedure took about 2 hr due to the heating and subsequent cooling required for assembly and disassembly.

The metal parts were rinsed with heptane, and the heptane rinse was saved for IR analysis. The metal parts were reused in subsequent tests when no damage was observed. Three bearings were used in the tests. One of these was used in tests T-1 through T-23. Another was used in test T-24. The third was used in tests T-25 through T-38.

The retainers (from both the running and static-bath tests) were wrapped in lint-free cloths and centrifuged to remove excess surface oil, then weighed. They were Soxhlet-extracted overnight in heptane, and the heptane extract was saved for IR analysis. Six retainers were used in the experiments. They were inspected visually and extracted after each use. If they had not changed appearance or dry weight, they were reused. In fact, none of the retainers were rejected in the course of the experiments. Even those from tests that exhibited lubricant degradation were unchanged in appearance or dry weight. The dry weights were reproducible within several mg, or about 0.1 % w/w. The extraction process removed all the oil, and no apparent loss of material by wear was observed.

The heptane solutions from the parts rinses and retainer extractions were concentrated by evaporation in a room-temperature, dry-nitrogen stream and analyzed by IR spectroscopy. No contaminants identifiable as coming from the phenolic resin were found. The collected oil residues were not weighed because reliable values could not be obtained due to sample loss during handling.

### 3. Results and Discussion

#### 3.1 Full Retainers/Well-Lubricated Bearings

The results of these experiments show that there is no net transfer of oil from a full retainer to the metal parts of a well-lubricated bearing. There is exchange of oil between the retainer and the oil applied to the metal parts, which can be accounted for by diffusional mixing of the two oils.

The weight of oil in each retainer before and after each test is listed in Table 1. There is no major change in oil weight during the tests, for either the running or static tests. This is expected since the long-term absorption of oil by cotton-phenolic material is slow. From Figure 1, we can estimate a weight increase of about 5–8 mg due to long-term absorption during our longest experiments, which is only slightly larger than our experimental error in the measurements. The retainers impregnated with POE seem to lose oil, and those impregnated with PAO seem to gain oil. No such difference in behavior is observed in the tests using poorly lubricated metal parts.

Table 1. Full Retainer Oil Weights. (Tests with Well-Lubricated Bearings or Oil Baths)

Sample Number*	Original Retainer Oil	Time	Oil Weight (mg)		
			Before ( $\pm 3$ mg)	After ( $\pm 3$ mg)	Change ( $\pm 4$ mg)
B-1	POE	1 hr	56	56	0
B-2	POE	5 hr	60	56	-4
B-3	POE	1 day	63	60	-3
B-4	PAO	5 hr	54	59	+5
B-5	PAO	1 day	54	62	+8
B-6	PAO	1 hr	45	49	+4
B-17	PAO	1 day	57	62	+5
B-18	PAO	6 days	60	67	+7
B-19	PAO	3 hr	53	57	+4
B-20	POE	1 day	63	60	-3
B-21	POE	1 hr	71	67	-4
B-22	POE	11 days	62	59	-3
T-1	POE	4 hr	54	n. m. <sup>†</sup>	n. m.
T-2	POE	8 days	50	n. m.	n. m.
T-3	PAO	4 hr	48	n. m.	n. m.
T-4	PAO	8 days	51	n. m.	n. m.
T-17	PAO	2 days	54	58	+4
T-18	PAO	6 days	57	62	+5
T-19	PAO	18 hr	49	54	+5
T-20	POE	3 days	74	70	-4
T-21	POE	1 day	76	72	-4
T-22	POE	11 days	65	61	-4

\* Sample designations beginning with B are static oil-bath tests; those beginning with T are operating-bearing tests. Times given for operating-bearing tests are time within the bearing, most of which is spent in operation.

<sup>†</sup>n. m. means "not measured."

As mentioned above, the amount of oil applied to the parts in the running tests is highly variable ( $30 \pm 20$  mg), and neither the bearings nor the residues were weighed. However, we can estimate that there was no major loss of oil from the parts as a function of time because the amount of dilution needed to bring the IR absorbances into the correct range for analysis was essentially the same for all the parts residues, and was about the same as needed for the retainer residues. In fact, this observation leads us to conclude that the amount of oil added to the parts errs on the high rather than the low side, and that the amount of oil applied to the parts was coincidentally similar to that in the full cages.

Figure 5 shows typical IR spectra obtained from the heptane extracts of cages in the static tests, in which fully impregnated cages were kept in room-temperature baths of the oil with which they were not impregnated. The ratio of ester to hydrocarbon peak intensities shows mixing of PAO and POE in the extracted oil. The results for all of the static tests are given in Figure 6 and Table 2. The fraction of oil originally impregnated into the retainer (called "retainer oil" in Figures 3, and 5-8) decreases the longer the retainer is stored in the oil bath. The oil in the cage goes from 100% retainer oil to about 40% retainer oil and 60% bath oil in about 12 days. This result is found whether the POE or the PAO is the original retainer oil. The data suggest that the POE may not transfer as well as the PAO, but the differences are well within the experimental scatter. The bath oil is replacing the original retainer oil, but there is no large increase in the weight of oil within the cage. The error bars on the points are those for the IR ratio measurement. There is more scatter in the data than can be accounted for by the IR measurement itself. This indicates additional sources of experimental error, such as varying amounts of ester contamination from the heptane solvent. The curves are meant to guide the eye only, and are not fit to the data.

Most of the exchange happens quickly, within a day or two. This is consistent with diffusional mixing of the two oils. The diffusion coefficients of these oils into the oil in the capillaries can be estimated to be  $1 \times 10^{-7}$  cm<sup>2</sup>/s. (The diffusion of oil into the phenolic resin itself is much slower.) The half-time for diffusion through distances comparable to the lengths of the capillaries in the separators is a few hours to a few days, similar to our experimental results. The diffusion of one oil through the other in the capillaries cannot be modeled accurately because of the complicated shape of ball-bearing retainers, which present a variety of paths of different lengths to a diffusing molecule. Also, the level of precision of these experiments does not warrant a detailed analysis.

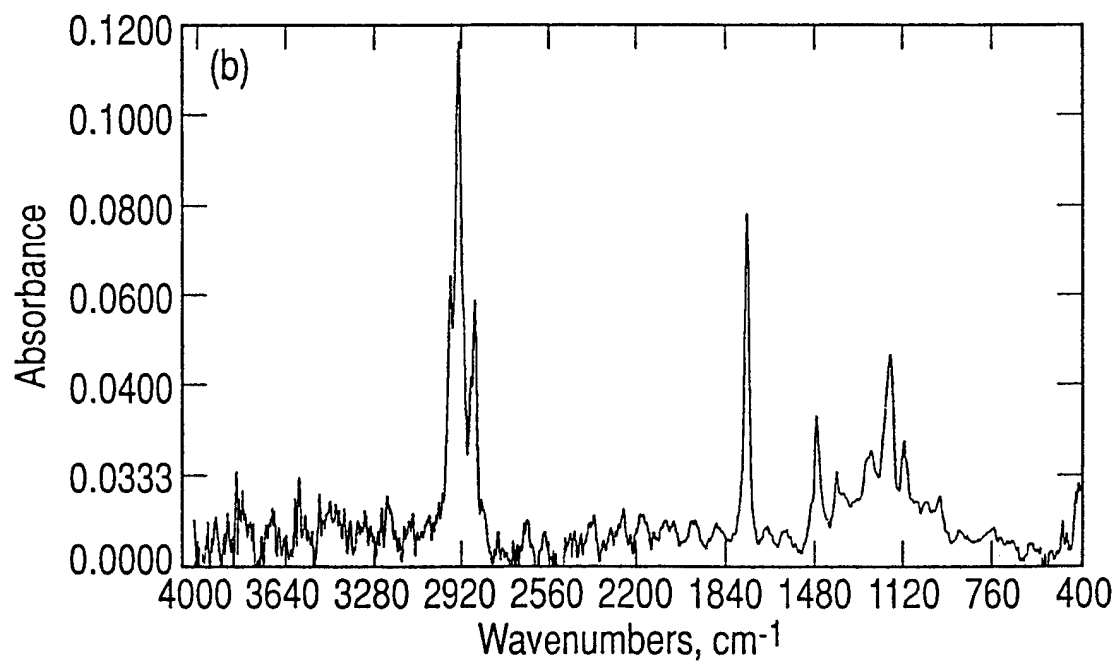
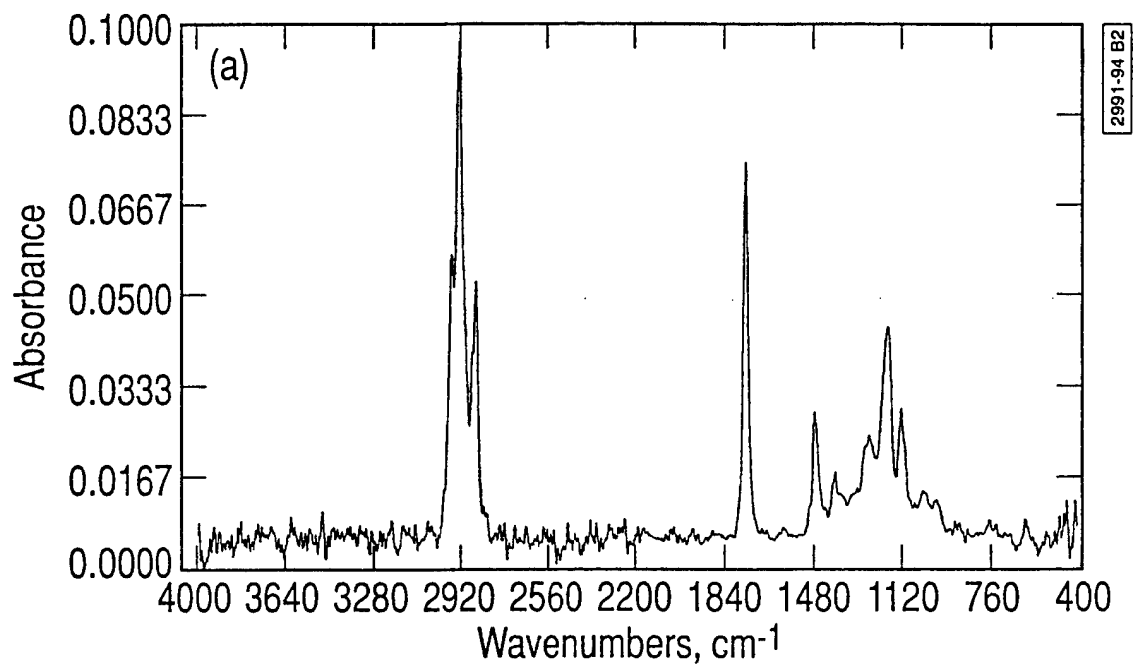

Figure 5. Infrared spectra for heptane extract of retainers from static oil bath tests. (a) Test B-3, in which a cage containing POE was placed in a PAO bath for 1 day. (b) Test B-22, in which a cage containing POE was placed in a PAO bath for 11 days.

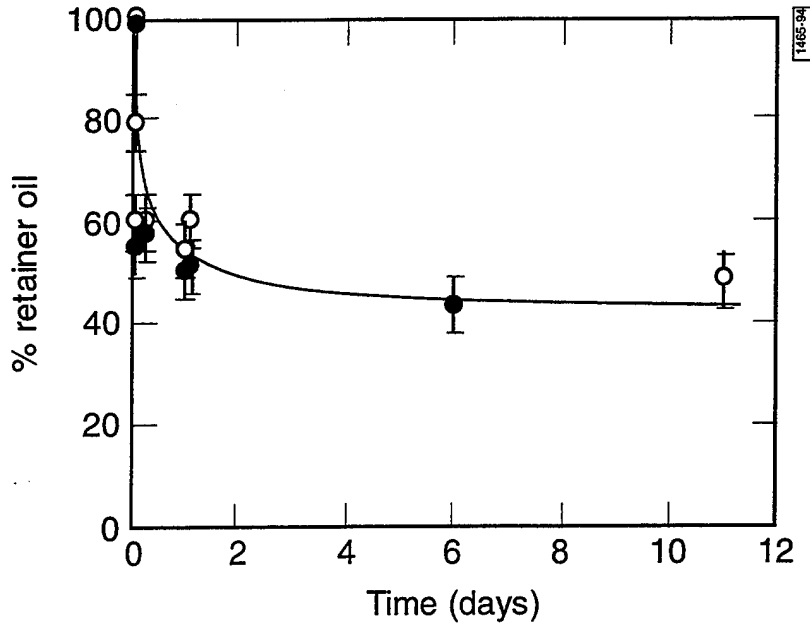

Figure 6. Oil exchange between fully impregnated retainers and static oil bath. "Retainer Oil" is the oil originally impregnated into the retainer.  $\circ$  is data for POE retainer oil;  $\bullet$  is data for PAO retainer oil. Retainers originally contain 100% retainer oil; this quantity decreases as bath oil mixes with the oil in the retainer. Error bars represent errors in IR analysis only.

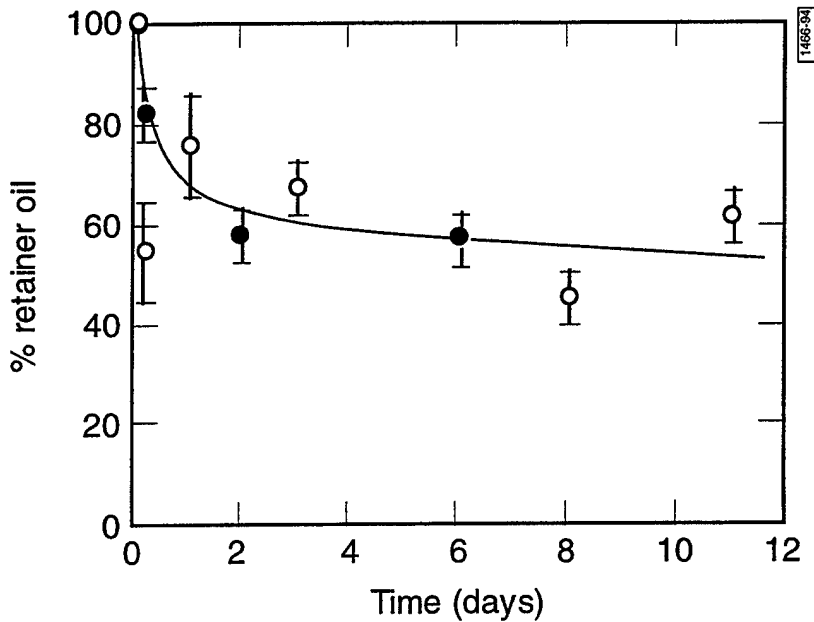

Figure 7. Oil exchange between fully impregnated retainers and oil in operating bearing: oil residue from retainer. "Retainer Oil" is the oil originally impregnated into the retainer.  $\circ$  is data for POE retainer oil;  $\bullet$  is data for PAO retainer oil. Retainers originally contain 100% retainer oil; this quantity decreases as oil from the metal parts mixes with oil in the retainer. Error bars represent errors in IR analysis only.

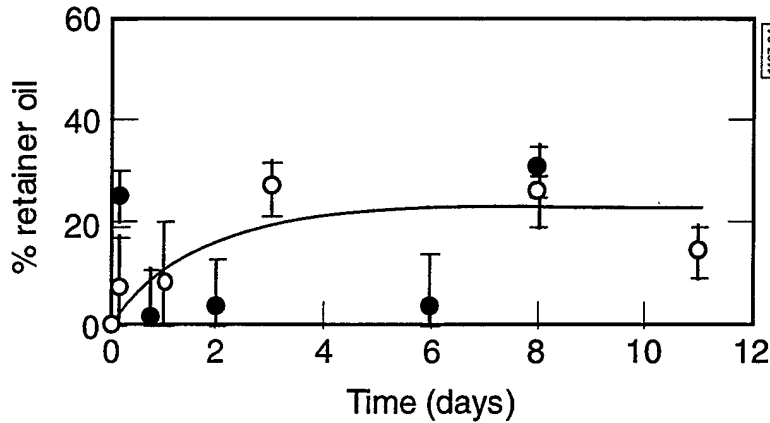

Figure 8. Oil exchange between fully impregnated retainers and oil in operating bearing: Oil residue from parts. "Retainer Oil" is the oil originally impregnated into the retainer. O is data for POE retainer oil; ● is data for PAO retainer oil. Parts originally contain 0% retainer oil; this quantity increases as oil from the retainer mixes with the oil on the parts. Error bars represent errors in IR analysis only.

The exchange of oil between metal parts and separators in operating bearings is shown in Figures 7 and 8 and Table 2. The cages absorb oil from the parts (Figure 7) in the running tests, just as they do in the static tests. The process is slower and less extensive in the running tests, which could be due to the smaller amount of parts oil present in the running tests compared to the amount of bath oil present in the static tests. In the static tests, the retainers are submerged in baths containing several grams of oil, all readily available to the retainer surfaces. At thermodynamic equilibrium, there will be a uniform concentration of the two oils in the bath (or on the

Table 2. Oil Composition After Tests. (Retainer Originally Full, Well-Lubricated Bearings)

Original Retainer Oil POE			Original Retainer Oil PAO		
Time/Test	% POE (retainer)	% POE (parts)	Time/Test	% POE (retainer)	% POE (parts)
1 hr/bath	60	--	1 hr/bath	45	--
1 hr/bath	76	--	3 hr/bath	75	--
4 hr/brg	55	< 10	4 hr/brg	17	74
5 hr/bath	60	--	5 hr/bath	49	--
1 d/bath	55	--	1 d/bath	49	--
1 d/bath	61	--	1 d/bath	48	--
1 d/brg	76	< 10	1 d/brg	contam.	98
3 d/brg	68	27	2 d/brg	41	97
8 d/brg	46	25	6 d/bath	55	--
11 d/bath	48	--	6 d/brg	42	96
11 d/brg	63	15	8 d/brg	29	70

\*"bath" means static bath test; "brg" means operating bearing test.

parts) and cage; the amount of cage oil left in the cage will then be very small. The amount of parts oil in the running tests, however, is comparable to the amount of cage oil. Therefore, the amount of retainer oil left in the cage will always be higher in the running tests than the static tests. In addition, all of the parts oil in the running tests is not readily available to exchange into the cage: some is on the raceways and lands of the bearing and only slowly delivered to the actively absorbing retainer surfaces (if at all).

Oil from the retainer is found in the oil washed from the parts in the running tests (Figure 8). This is expected since there is no measurable increase in oil weight contained in the retainer. The fraction of retainer oil found on the parts is low, and the data are very scattered in these experiments. The ester contaminant in the solvent has very little effect on these results because the amount of solvent used in the washes is much smaller than that used in the extractions. Several wipes in which the separators were wrapped during centrifugation were extracted before and after use, and the residues obtained after use were analyzed by IR. They contain both parts and retainer oil, with a slightly higher ratio of retainer to parts oil than present in the parts rinse residues. This indicates that most of the exchange involves the oil on the surface of the cages, and the mixing of parts oil far from the cage with parts oil near the cage during bearing operation is not rapid.

The time scale for oil exchange between the retainer and metal parts in operating bearings is about the same as in the static oil bath. Thus, diffusional mixing, slowed by oil transport to the active surfaces, is a sufficient explanation for the process, and other effects, such as centrifugal forces or other consequences of bearing action, do not need to be invoked.

These experiments clearly show that under operating conditions with a fully impregnated separator and a well-lubricated bearing, there is exchange between the oil originally impregnated into the separator and the oil applied to the metal parts. However, there is no measurable net delivery of oil from the cage to the parts, and simple diffusional mixing can describe the observed time dependence of the process. This is different from the experiments on oil circulation in bearings with sintered nylon retainers, in which oil was found to mix on a time scale of hours,<sup>1</sup> faster than expected for diffusion.

### **3.2 Partially Filled Retainers/Well-Lubricated Bearings**

For partially filled retainers in a well-lubricated bearing, there is net transfer of oil from the metal parts to the retainer. There is probably also some diffusional mixing of the two oils, but the general effect is absorption of oil into the retainer.

The weight of oil in each cage increases during each test (Table 3). This is true for both the static-bath tests and the operating-bearing tests, and for both POE and PAO oils originally impregnated into the cages.

The amount of oil residue collected from the metal parts after each test was not measured, but can be assumed to be less than that in the tests that were run with full separators. The amount of dilution required to bring the IR absorbances into the correct range for analysis was generally less

Table 3. Partially Filled Retainer Oil Weights. (Tests with Well-Lubricated Bearings or Oil Baths)

Sample Number*	Original Retainer Oil	Time	Oil Weight (mg)		
			Before (±3 mg)	After (±3 mg)	Change (± 4 mg)
B-7	PAO	1 day	32	52	+20
B-8	POE	1 day	35	47	+12
B-9	POE	6 days	35	51	+16
B-10	PAO	6 days	34	70	+36
B-11	POE	1 day	40	55	+15
B-12	POE	1 hr	39	46	+7
B-13	POE	8 days	37	57	+20
B-14	PAO	49 days	35	75	+40
B-15	PAO	1 day	30	59	+29
B-16	PAO	1 hr	29	42	+14
T-5	PAO	4 hr	33	50	+17
T-6	PAO	1 day	31	48	+17
T-7	POE	1 day	37	47	+10
T-8	PAO	9 days	34	61	+27
T-9	POE	7 days	38	54	+16
T-10	POE	4 hr	38	55	+17
T-11	POE	2 days	41	64	+23
T-12	POE	7 days	39	57	+18
T-13	POE	3 days	41	60	+19
T-14	PAO	49 days	35	61	+26
T-15	PAO	1 day	30	53	+23
T-16	PAO	4 hr	29	45	+16

\* Sample designations beginning with B are static oil-bath tests, those beginning with T are operating-bearing tests. Times given for operating bearing tests are time within the bearing, most of which is spent in operation.

than that needed in the full-retainer tests, and less than that needed for the retainer residues in the partially filled retainer tests. Thus, there is probably less oil on the parts after the tests than in the cage.

Figure 9 and Table 4 show the mixing of the two oils in partially filled retainers kept in room-temperature baths of the oil with which they were not impregnated. The amount of original retainer oil decreases with increasing storage time, from 100% to about 20% over eight days. This is a much larger and faster change than in the tests with full retainers. Diffusional mixing is probably occurring in the partially filled retainer tests as in the full-retainer tests, but the overwhelming effect is the continued filling of the capillaries in the cotton-phenolic material with the available bath oil.

This absorption of oil from sources exterior to the retainer into partially filled retainers occurs even in an operating bearing, as shown in Figure 10 and Table 4. The fraction of oil originally

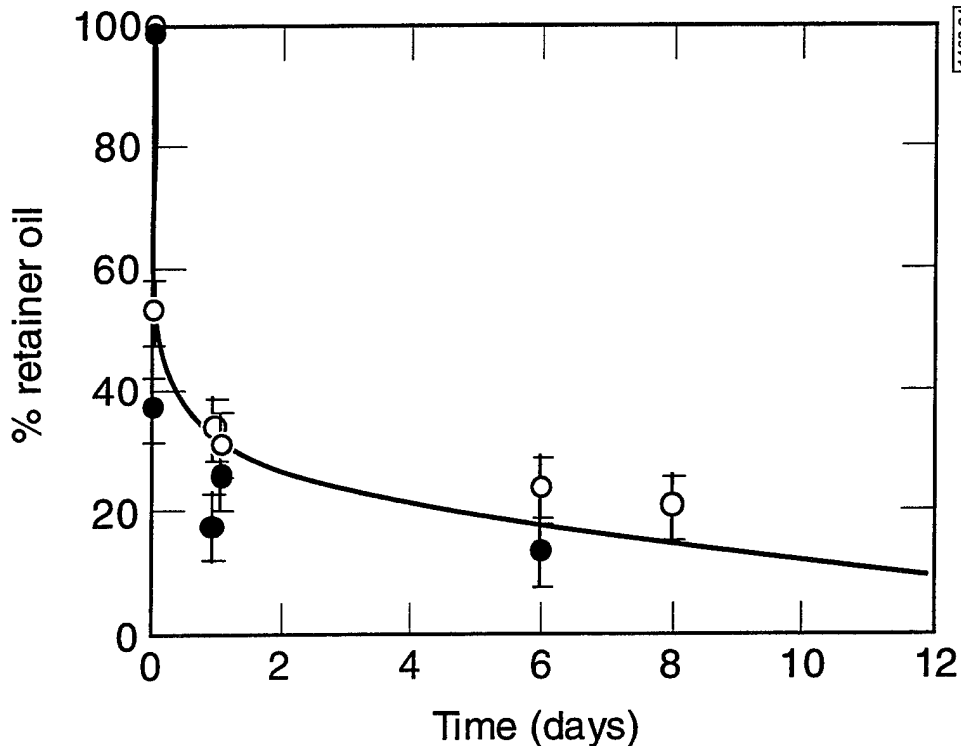

Figure 9. Oil exchange between partially impregnated retainers and static oil bath. "Retainer Oil" is the oil originally impregnated into the retainer. ○ is data for POE retainer oil; ● is data for PAO retainer oil. Retainers originally contain 100% retainer oil(although the retainers are not fully impregnated, what oil they do contain is 100% retainer oil); this quantity decreases as bath oil is absorbed into the retainer. Error bars represent errors in IR analysis only.

Table 4. Oil Composition After Test. (Retainer Originally Partially Full, Well-Lubricated Bearings)

Original Retainer Oil POE			Original Retainer Oil PAO		
Time/Test	% POE (retainer)	% POE (parts)	Time/Test	% POE (retainer)	% POE (parts)
1 hr/bath	53	--	1 hr/bath	62	--
4 hr/brg	58	8	1 hr/brg	53	79
1 d/bath	31	--	1 hr/brg	53	100
1 d/bath	34	--	1 d/bath	74	--
1 d/brg	48	13	1 d/bath	82	--
2 d/brg	53	13	1 d/brg	60	98
3 d/brg	48	10	1 d/brg	61	100
5 d/bath	24	--	6 d/bath	86	--
7 d/brg	39	14	9 d/brg	68	97
7 d/brg	48	13	49 d/bath	93	--
8 d/bath	20	--	49 d/brg	56	91

\*"bath" means static bath test; "brg" means operating bearing test.

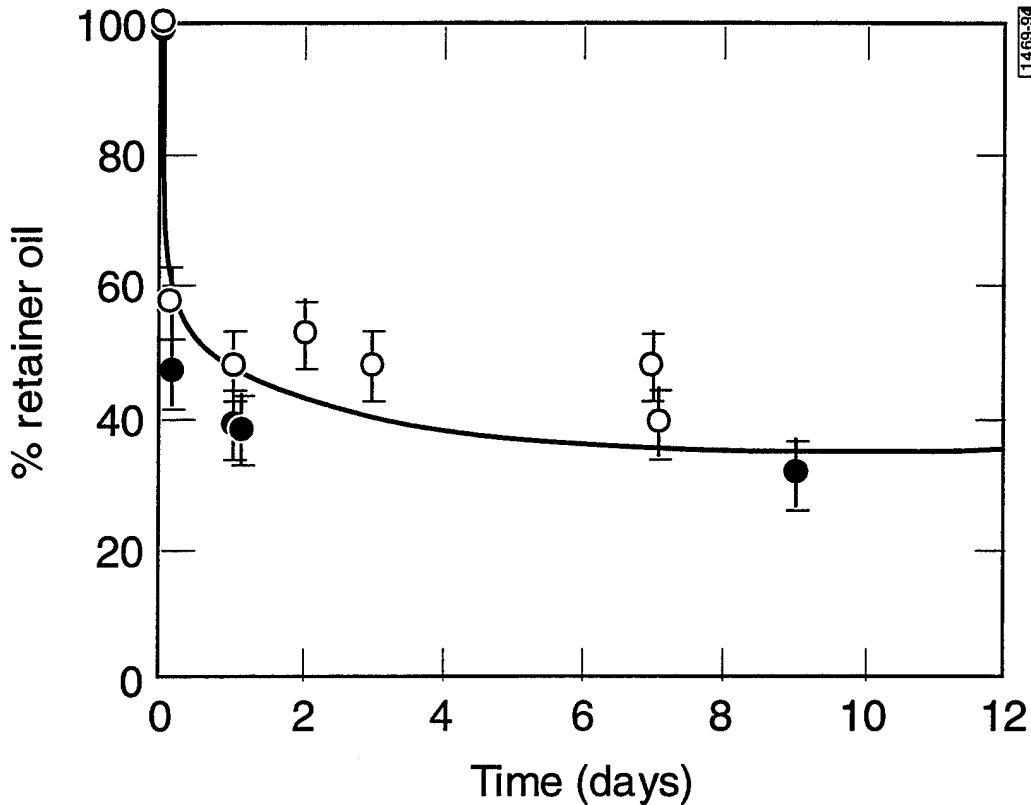

Figure 10. Oil exchange between partially impregnated retainers and oil in operating bearing. "Retainer Oil" is the oil originally impregnated into the retainer. ○ is data for POE retainer oil; ● is data for PAO retainer oil. Retainers originally contain 100% retainer oil (although the retainers are not fully impregnated, what oil they do contain is 100% retainer oil); this quantity decreases as oil from the parts is absorbed into the retainer. Error bars represent errors in IR analysis only.

impregnated into the cage decreases the longer the cage is in contact with the other oil, indicating a change in composition. After about six days, the oil in the cage has become 40% original retainer oil and 60% oil from the metal parts. The absorption of oil by the cage in the operating bearing (both the net absorption and the mixing) is less extensive and slower than in the static bath because of the difference in availability of the oil to the retainer, as discussed above for the full-retainer experiments. The partially full retainers contain less original retainer oil and more parts oil at any given time than do the full retainers because the partially full retainers are absorbing oil from the parts to completely fill their internal capillaries.

The residues from the parts rinses and the wipe extractions had only a few percent retainer oil. This amount could not be measured accurately in these experiments, and should be thought of as almost zero. Very little oil is leaving the partially filled retainer by diffusional mixing. Thus, a partially filled retainer absorbs oil from the metal parts of a bearing until the cage is full. There is probably a small amount of diffusional mixing of the oils, but there is no net delivery of oil to the metal parts, only a withdrawal.

### 3.3 Full Retainers/Poorly Lubricated Bearings

The experiments reported here show that there is no significant delivery of oil from the fully impregnated retainer to the metal parts of a poorly lubricated bearing, which causes the oil on the metal parts to degrade leading to damage to the metal parts.

The weight of oil in each cage before and after each test is listed in Table 5. As can be seen, there is no major change in retainer oil weight during the tests.

The oil samples retrieved from the originally full retainers contain almost no oil from the parts (Table 6). In fact, the amount of ester seen in the oil samples from retainers that had been originally filled with PAO can be accounted for as ester contaminant from the solvent. The 2-hr tests, in which only a few rotations by hand were given to the bearings, can be used as an illustration of transfer of oil between the **surfaces** of the parts and separators since 2 hr is not enough time for

Table 5. Retainer Oil Weights. (Tests with Poorly Lubricated Bearings)

Sample Number	Original Retainer Oil	Time	Oil Weight (mg)		
			Before ( $\pm 3$ mg)	After ( $\pm 3$ mg)	Change ( $\pm 4$ mg)
T-23	POE	1 day	72	70	-2
T-24	POE	7 days	69	66	-3
T-25	PAO	2 days	55	55	0
T-26	PAO	11 days	60	60	0
T-27	PAO	2 hr	61	n.m.*	--
T-30	PAO	2 hr	54	55	+1
T-32	POE	2 hr	71	71	0
T-33	POE	2 hr	75	76	+1
T-35	PAO	2 days	62	63	+1
T-36	PAO	8 days	59	59	0
T-37	POE	2 days	74	75	+1
T-38	POE	8 days	80	81	+1

\* n.m. means "not measured"

Table 6. Oil Composition After Test. (Retainer Originally Full, Poorly Lubricated Bearing)

Original Retainer Oil POE			Original Retainer Oil PAO		
Time	% POE (retainer)	% POE (parts)	Time	% POE (retainer)	% POE (parts)
2 hr	100	31	2 hr	0	97
2 hr	100	24	2 hr	3	100
1 day	97	53	2 days	*	68
2 days	100	55	2 days	8	70
7 days	100	53	8 days	12	60
8 days	100	60	11 days	10	68

\* oils contaminated

much transfer of oil to or from the interior of the separators. These retainers contain no detectable oil that was originally placed on the parts. There is no significant difference between the composition of the oil samples in the tests that ran for several days and the tests that were rotated by hand. The retainers originally filled with POE still contain 100% POE. The retainers originally filled with PAO have < 20% POE, which, as explained above, should be viewed as almost no ester. These results show that the full cages have absorbed almost no oil from the lightly lubricated bearings under the conditions of these tests.

The full retainers have not delivered any significant amount of oil to the lightly lubricated metal parts. The oil composition results for the oil collected from the parts are complicated by the presence of the ester impurity in the solvent, which can account for up to a value of 15% POE in the parts washes from poorly lubricated bearings. Thus the 2-hr tests show essentially no oil from the retainer in the parts washes. The parts washes from the tests that ran several days have approximately 50% retainer oil after correcting for the ester contaminant. This is only about 5 mg of oil. This amount of loss from the cage is close to the detectability limit for oil loss from the retainer in these experiments, and was not detected. In the experiments reported above using well-lubricated bearings, there appeared to be a preferential loss of POE and gain of PAO by full retainers. No such preferential behavior was seen in the experiments using poorly lubricated bearings.

Three of the eight tests in which the bearings were run exhibited lubricant degradation, and in one of these tests, the metal parts were lightly banded. The retainers in all cases were lubricated with POE, while the parts were lubricated with PAO. The tests were T-23 (one day), T-24 (seven days), and T-38 (eight days). There was black debris, probably degraded lubricant, present in the raceways and on the balls, and the balls in test T-24 were lightly banded. The full retainers had not prevented damage to the bearings; they did not supply sufficient oil for normal bearing operation.

No strong conclusions should be drawn from the fact that only tests in which the metal parts had been coated with a minimal amount of PAO showed degradation. It is possible that the POE and its antiwear additive are more effective under the conditions of our tests than the PAO and its antiwear additives. However, it may be that the amount of oil applied to the parts is variable enough that with such a small number of tests (only eight) it is coincidence that this grouping of results took place.

#### 4. Conclusions

These experiments profile for the first time the transfer of oil between cotton-phenolic ball separators and the metal parts of operating ball bearings. A full retainer exchanges oil with a well-lubricated bearing, probably by diffusional mixing. There is no net delivery of oil from the retainer to the metal parts of the bearing. A partially filled retainer (such as one that has been incompletely impregnated) absorbs oil from a well-lubricated bearing even during operation, thus drying the bearing. A full retainer does not exchange a significant amount of oil with a poorly lubricated bearing. This could have serious consequences for lightly lubricated systems such as are found in some spacecraft, i.e., rate gyroscopes and some reaction/momentum wheels. At most, only a few milligrams of oil were delivered to the metal parts from a retainer of this size, which is insufficient for a bearing under the conditions of these tests, and lubricant degradation occurred in some tests. Cotton-phenolic retainers should not be expected to provide oil to an operating bearing; either a sufficient amount of lubricant for the projected system life should be provided initially (and this lubricant should be constrained from leaving the bearing), or a different oil delivery mechanism should be provided.

## References

1. Martin Roberts, "A Study of Oil Circulation in the R4 Spin-Axis Bearing with Sintered Nylon Ball Retainer," *Proc. Gyro Spin-Axis Hydrodynamic Bearing Symp., Vol. II*, Cambridge MA, Dec. 1966.
2. P. A. Bertrand, "Oil Absorption into Cotton-Phenolic Material," *J. Mater. Sci.*, 8(7), 1749 (1993).
3. P. D. Fleischauer and M. R. Hilton, "Assessment of the Tribological Requirements of Advanced Spacecraft Mechanisms," *Mater. Res. Soc. Symp.* 140, 2 (1989).
4. D. J. Carré, R. Bauer, and P. D. Fleischauer, "Chemical Analysis of Hydrocarbon Grease from Spin Bearing Tests," *ASLE Trans.* 26(4), 475 (1983).
5. P. M. Gupta, "Frictional Instabilities in Ball Bearings," *Tribol. Trans.* 31, 258(1988).
6. S. Lowenthal, E. A. Boesinger, and A. D. Donley, "Observations of Cage Instability," DOD/Instrument Bearing Working Group International Rolling Element Bearing Symposium, Boston, MA, April, 1991.
7. E. P. Kingsbury, "Stable Ball Bearings for Control Moment Gyro Service," *Space Tech. Proc. of the Conf. and Exp.*, Sept. 1985. Dearborn, Mich., Soc. of Man. Eng., 1985, pp. 5-35-5-45.
8. W. Morales, W. R. Jones, Jr., and D. H. Buckley, "Analysis of a Spacecraft Instrument Ball Bearing Assembly Lubricated by a Perfluoroalkylether," NASA Technical Memorandum 87260, March, 1986.
9. C. H. Hannan, "Observations of Oil and Water Absorption Characteristics of Spin Axis Bearing Retainers," *Proc. Gyro Spin-Axis Hydrodynamic Bearing Symposium, Vol. II*, Cambridge MA, Dec. 1966.
10. A. A. Fote, R. A. Slade, and S. Feuerstein, "Thermally Induced Migration of Hydrocarbon Oil," *J. Lubr. Technol.* 99, 158 (1977).

## TECHNOLOGY OPERATIONS

The Aerospace Corporation functions as an "architect-engineer" for national security programs, specializing in advanced military space systems. The Corporation's Technology Operations supports the effective and timely development and operation of national security systems through scientific research and the application of advanced technology. Vital to the success of the Corporation is the technical staff's wide-ranging expertise and its ability to stay abreast of new technological developments and program support issues associated with rapidly evolving space systems. Contributing capabilities are provided by these individual Technology Centers:

**Electronics Technology Center:** Microelectronics, solid-state device physics, VLSI reliability, compound semiconductors, radiation hardening, data storage technologies, infrared detector devices and testing; electro-optics, quantum electronics, solid-state lasers, optical propagation and communications; cw and pulsed chemical laser development, optical resonators, beam control, atmospheric propagation, and laser effects and countermeasures; atomic frequency standards, applied laser spectroscopy, laser chemistry, laser optoelectronics, phase conjugation and coherent imaging, solar cell physics, battery electrochemistry, battery testing and evaluation.

**Mechanics and Materials Technology Center:** Evaluation and characterization of new materials: metals, alloys, ceramics, polymers and their composites, and new forms of carbon; development and analysis of thin films and deposition techniques; nondestructive evaluation, component failure analysis and reliability; fracture mechanics and stress corrosion; development and evaluation of hardened components; analysis and evaluation of materials at cryogenic and elevated temperatures; launch vehicle and reentry fluid mechanics, heat transfer and flight dynamics; chemical and electric propulsion; spacecraft structural mechanics, spacecraft survivability and vulnerability assessment; contamination, thermal and structural control; high temperature thermomechanics, gas kinetics and radiation; lubrication and surface phenomena.

**Space and Environment Technology Center:** Magnetospheric, auroral and cosmic ray physics, wave-particle interactions, magnetospheric plasma waves; atmospheric and ionospheric physics, density and composition of the upper atmosphere, remote sensing using atmospheric radiation; solar physics, infrared astronomy, infrared signature analysis; effects of solar activity, magnetic storms and nuclear explosions on the earth's atmosphere, ionosphere and magnetosphere; effects of electromagnetic and particulate radiations on space systems; space instrumentation; propellant chemistry, chemical dynamics, environmental chemistry, trace detection; atmospheric chemical reactions, atmospheric optics, light scattering, state-specific chemical reactions and radiative signatures of missile plumes, and sensor out-of-field-of-view rejection.