

ARMY RESEARCH LABORATORY



# Engineering Design of a Throat Valve Experimental Facility

Irving B. Osofsky  
Duane T. Hove  
William C. Derbes

ARL-CR-229

June 1995

prepared by

SPARTA, Inc.  
615 Nash Street, Suite 202  
El Segundo, CA 90245

under contract

DAAL02-90-C-0073

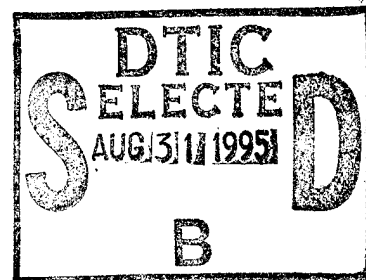

APPROVED FOR PUBLIC RELEASE; DISTRIBUTION IS UNLIMITED.

19950830 080

DTIC QUALITY INSPECTED 6

## **NOTICES**

Destroy this report when it is no longer needed. DO NOT return it to the originator.

Additional copies of this report may be obtained from the National Technical Information Service, U.S. Department of Commerce, 5285 Port Royal Road, Springfield, VA 22161.

The findings of this report are not to be construed as an official Department of the Army position, unless so designated by other authorized documents.

The use of trade names or manufacturers' names in this report does not constitute endorsement of any commercial product.

REPORT DOCUMENTATION PAGE			Form Approved OMB No. 0704-0188	
Public reporting burden for this collection of information is estimated to average 1 hour per response, including the time for reviewing instructions, searching existing data sources, gathering and maintaining the data needed, and completing and reviewing the collection of information. Send comments regarding this burden estimate or any other aspect of this collection of information, including suggestions for reducing this burden, to Washington Headquarters Services, Directorate for Information Operations and Reports, 1215 Jefferson Davis Highway, Suite 1204, Arlington, VA 22202-4302, and to the Office of Management and Budget, Paperwork Reduction Project(0704-0188), Washington, DC 20503.				
1. AGENCY USE ONLY (Leave blank)		2. REPORT DATE June 1995	3. REPORT TYPE AND DATES COVERED Final, Jul 93 - Dec 93	
4. TITLE AND SUBTITLE Engineering Design of a Throat Valve Experimental Facility			5. FUNDING NUMBERS C: DAAL02-90-C-0073	
6. AUTHOR(S) Irving B. Osofsky, Duane T. Hove, and William C. Derbes			Task 93-9273	
7. PERFORMING ORGANIZATION NAME(S) AND ADDRESS(ES) SPARTA, Inc. 615 Nash Street, Suite 202 El Segundo, CA 90245			8. PERFORMING ORGANIZATION REPORT NUMBER	
9. SPONSORING/MONITORING AGENCY NAMES(S) AND ADDRESS(ES) U.S. Army Research Laboratory ATTN: AMSRL-WT-NC Aberdeen Proving Ground, MD 21005-5066			10. SPONSORING/MONITORING AGENCY REPORT NUMBER  ARL-CR-229	
11. SUPPLEMENTARY NOTES Technical point of contact for this work is Audrey Mihalcin, U.S. Army Research Laboratory, ATTN: AMSRL-WT-NC, Aberdeen Proving Ground, MD 21005-5066.				
12a. DISTRIBUTION/AVAILABILITY STATEMENT  Approved for public release; distribution is unlimited.			12b. DISTRIBUTION CODE	
13. ABSTRACT (Maximum 200 words)  This report covers the design of a gas dynamic test facility. The facility studied is a medium-scale blast simulator. The primary use of the facility would be to test fast-acting, computer-controlled valves. The valve would be used to control nuclear blast simulation by controlling the release of high pressure gas from drivers into an expansion tunnel to form a shock wave. The development of the valves themselves is reported elsewhere. The facility is composed of a heated gas supply, driver tube, expansion tunnel, reaction pier, piping, sensors, and controls. The driver tube and heated gas supply are existing components. The expansion tunnel, piping, sensors, and controls are all new components. Much of the report is devoted to the design of the reaction pier and the development of heat transfer relations used in designing the piping and controls.				
14. SUBJECT TERMS  heat exchange, soil loading, shock tubes, blast simulation, test facilities			15. NUMBER OF PAGES 110	
			16. PRICE CODE	
17. SECURITY CLASSIFICATION OF REPORT UNCLASSIFIED	18. SECURITY CLASSIFICATION OF THIS PAGE UNCLASSIFIED	19. SECURITY CLASSIFICATION OF ABSTRACT UNCLASSIFIED	20. LIMITATION OF ABSTRACT  UL	

INTENTIONALLY LEFT BLANK.

## FOREWORD

The facility design effort reported here was performed under contract DAAL02-90-C-0037 to assist in the development of a Throat Valve Experimental Facility. Related design and installation activities were performed under contract DAAA15-87-C-0096 to support the design and implementation of a Pebble Bed Heater to fill the 1/6th Scale Test Bed driver. The civil and mechanical engineering design work of consultant Dr. Jerome Burns is gratefully acknowledged.

Accession For	
NTIS GRA&I	<input checked="" type="checkbox"/>
DTIC TAB	<input type="checkbox"/>
Unannounced	<input type="checkbox"/>
Justification	
By	
Distribution/	
Availability Codes	
Dist	Avail and/or Special
A-1	

INTENTIONALLY LEFT BLANK.

# TABLE OF CONTENTS

	<u>Page</u>
FOREWORD .....	iii
LIST OF FIGURES .....	vii
LIST OF SYMBOLS .....	ix
1. INTRODUCTION .....	1
2. BACKGROUND .....	2
2.1 TVEF Facility Description .....	2
2.2 Design Requirements .....	5
2.3 Site Soil Properties .....	6
3. CONCEPT TRADE STUDIES .....	7
3.1 Early Design Studies .....	7
3.2 Alternate Facility Configurations .....	8
3.2.1 100,000 lb Pad Supported Concept .....	8
3.2.2 100,000 lb Piggyback Concept .....	10
3.2.3 100,000 lb Side by Side Concept .....	10
3.2.4 100,000 lb Upgradable Pad Concept .....	14
3.2.5 400,000 lb Pad Supported Concept .....	14
3.3 Concept Selection .....	17
4. ENGINEERING DESIGN .....	18
4.1 Facility Design .....	18
4.1.1 Site Plan .....	18
4.1.2 Pier, Driver and Expansion Tube Overall Views .....	20
4.1.2.1 Concrete & Rails .....	21
4.1.2.2 Expansion Tube Supports, Rings & Longerons .....	22
4.1.2.3 Driver Thrust Frame .....	22
4.1.3 Driver Gas Supply System .....	23
4.1.4 Electrical Power System .....	25
4.1.5 Instrumentation and Control System .....	26

	<u>Page</u>
4.2 Facility Installation .....	27
4.3 Facility Operation .....	29
5. ESTIMATED COST AND SCHEDULE .....	34
6. SUMMARY .....	36
6.1 Conclusions .....	36
6.2 Recommendations .....	36
7. REFERENCES .....	39
APPENDIX A: Design Calculations .....	41
APPENDIX B: Heat Transfer Models .....	91
DISTRIBUTION LIST .....	103

## LIST OF FIGURES

<u>Figure</u>		<u>Page</u>
1.	Existing Driver Section .....	3
2.	Pebble Bed Heater Schematic - Not the 1/6th Scale Design .....	4
3.	100,000 lb Pad Supported Concept .....	9
4.	100,000 lb Piggy Back Concept .....	11
5.	Mobile Work Platform and Sliding Expansion Tube Detail .....	12
6.	100,000 lb Side by Side Concept .....	13
7.	Upgradable 100,000 lb Pad Supported Concept .....	15
8.	400,000 lb Pad Supported Concept .....	16
9.	Effect of Fill Tube Heating on Driver Gas Inlet Temperature .....	24
10.	Estimate of TVEF Driver Gas Fill Time .....	30
11.	Effect of Heat Transfer to the Driver Wall .....	31
12.	Effect of Terminating Driver Gas Filling .....	32
13.	Extending Test Time by Driver Gas Venting .....	33
14.	TVEF Completion Schedule .....	35

INTENTIONALLY LEFT BLANK.

## LIST OF SYMBOLS

### English

A	area
$C_p$	specific heat at constant pressure
$C_v$	specific heat at constant volume
$C_1$	constant defined in Reference 2
D	diameter
e	specific energy
E	energy
g	gravity
h	specific enthalpy
$h_c$	heat transfer coefficient
k	conductivity
$K_i$	constants
m	mass
Nu	Nussult number
P	pressure
Pr	Prandtl number
Q	heat transferred to the wall
R	gas constant
Ra	Raleigh number
t	time
T	temperature
V	volume

### Greek

$\gamma$	ratio of specific heats
$\mu$	viscosity
$\nu$	kinematic viscosity ( $\mu/\rho$ )
$\rho$	density
T	filling time

### Subscripts

a	ambient
i	into the driver
v	venting out of the driver
T	throat
W	wall
0	initial condition

INTENTIONALLY LEFT BLANK.

X

## 1. INTRODUCTION

As part of an ongoing effort to improve nuclear blast simulation techniques, the US Army Research Laboratory (ARL) has been studying the use of computer controlled throat valves to replace conventional diaphragms used in shock tubes. Diaphragms are consumed in testing and are costly and difficult to mount in large sizes. Throat valves would be reusable, easy to set up and operate and have the potential for eliminating the requirement for heating the driver gas to achieve high fidelity nuclear waveforms.

Throat valve studies and related research efforts have been aimed at providing the Defense Department with the capacity to conduct nuclear blast and thermal survivability testing on full scale tactical vehicles in the Large Blast/Thermal Simulator being built in White Sands, New Mexico. In support of this objective, a 1/6th Scale Test Bed (Test Bed) has been assembled as a technology demonstrator and is currently undergoing characterization testing at Aberdeen Proving Ground. Both the LB/TS and the Test Bed employ heated nitrogen driver gas with double diaphragms to produce nuclear weapon waveforms in the expansion tubes. Heated driver gas is required to remove a density (and therefore, dynamic pressure) discontinuity at the interface between the driver and driven gas. Controlled metering of ambient temperature driver gas has been shown by computation to achieve the same effect. If throat valves prove successful, considerable cost savings will be realized and test preparation time reduced.

A Throat Valve Experimental Facility (TVEF) is planned to develop the computer controlled throat valves without interfering with ongoing Test Bed technology development research. The TVEF is to be located on Spesutie Island, Aberdeen Proving Grounds in the immediate vicinity of the Test Bed and will make maximum use of existing equipment including the Test Bed driver gas supply system.

Section 2 provides background information including design requirements. Section 3 summarizes the concept design trade studies performed and the selection of the baseline facility configuration. A preliminary facility design is presented in Section 4 and Section 5 provides a cost estimate for the remaining design work and the facility fabrication and installation. Section 6 summarizes the study results and Section 7 lists the references.

## 2. BACKGROUND

This section provides a general description of the TVEF, the requirements upon which the designs were based and a summary of the soil properties at the Spesutie Island site.

### 2.1 TVEF Description

The TVEF consists of a pressure vessel called a shock tube driver, an expansion tube, a reinforced concrete pad to support the driver and expansion tube and react the axial load when the throat valve is tested, a heated gas supply system and an instrumentation and control system.

The TVEF driver is being adapted from hardware available through a previous BRL project (Figure 1). The 3.66 m (144 in) long driver was formed of three identical sections. A 0.36 m (29.5 in) diameter 1500 lb weld neck flange is welded to each end of a 0.61 m (24 in) long tube with a 0.29 m (11.5 in) I.D. and a 0.032 m (1.25 in) wall thickness. The three sections are each bolted together with sixteen 2 1/4 inch bolts. The upstream end of the driver is closed by a 0.36 m diameter 1500 lb blind flange. The interior volume of the driver is 0.25 m<sup>3</sup> (15000 in<sup>3</sup>) and the wall area is 3.37 m<sup>2</sup> (5200 in<sup>2</sup>).

An existing expansion tube is a welded steel pipe 30.5 m (100 ft) long with a 0.76 m (30 in) I.D. and a 0.0035 m (0.137 in) thick wall. The tube is presently cut into four sections and is badly rusted.

The Test Bed driver is pressurized with heated gas by a unique SPARTA designed and installed gas supply system (c.f., Figure 2). A constant volume cryogenic pump supplies up to 1.6 kg (32 GPM) of Liquid Nitrogen (LN<sub>2</sub>) at a constant flow rate independent of backpressure; lower flow rates are achieved by venting part of the LN<sub>2</sub> after it leaves the pump. The LN<sub>2</sub> is vaporized and heated in a single pass through an electrically preheated Pebble Bed Heater (PBH). A remotely controlled LN<sub>2</sub> bypass system provides positive control of the PBH outlet gas temperature by mixing selected amounts of LN<sub>2</sub> with the heated nitrogen gas. The PBH mixer is designed for a maximum metal temperature of 670 °K (750 °F) and a maximum pressure of 153 atmospheres (2250 psig).

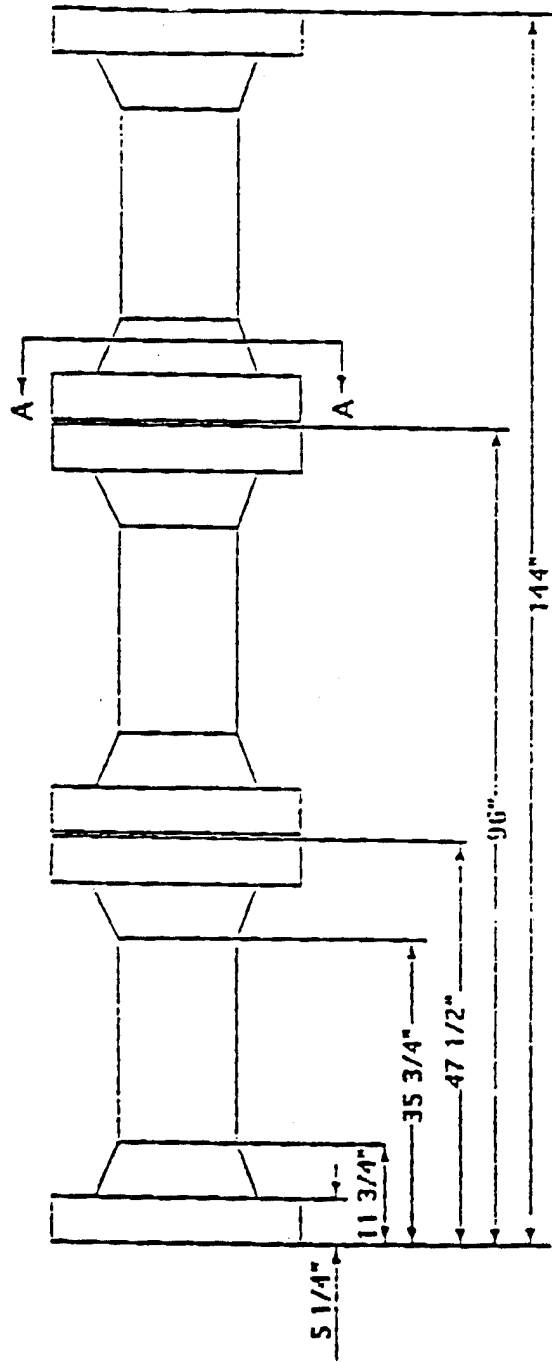

3

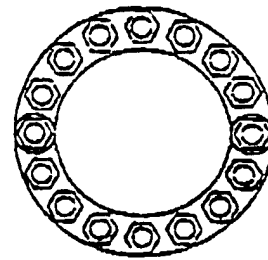

Standard 1500 lb Welding Neck Flange

29 1/2 in OD

16 - 2 1/4 in bolts

Section A-A

Figure 1. Existing Driver Section

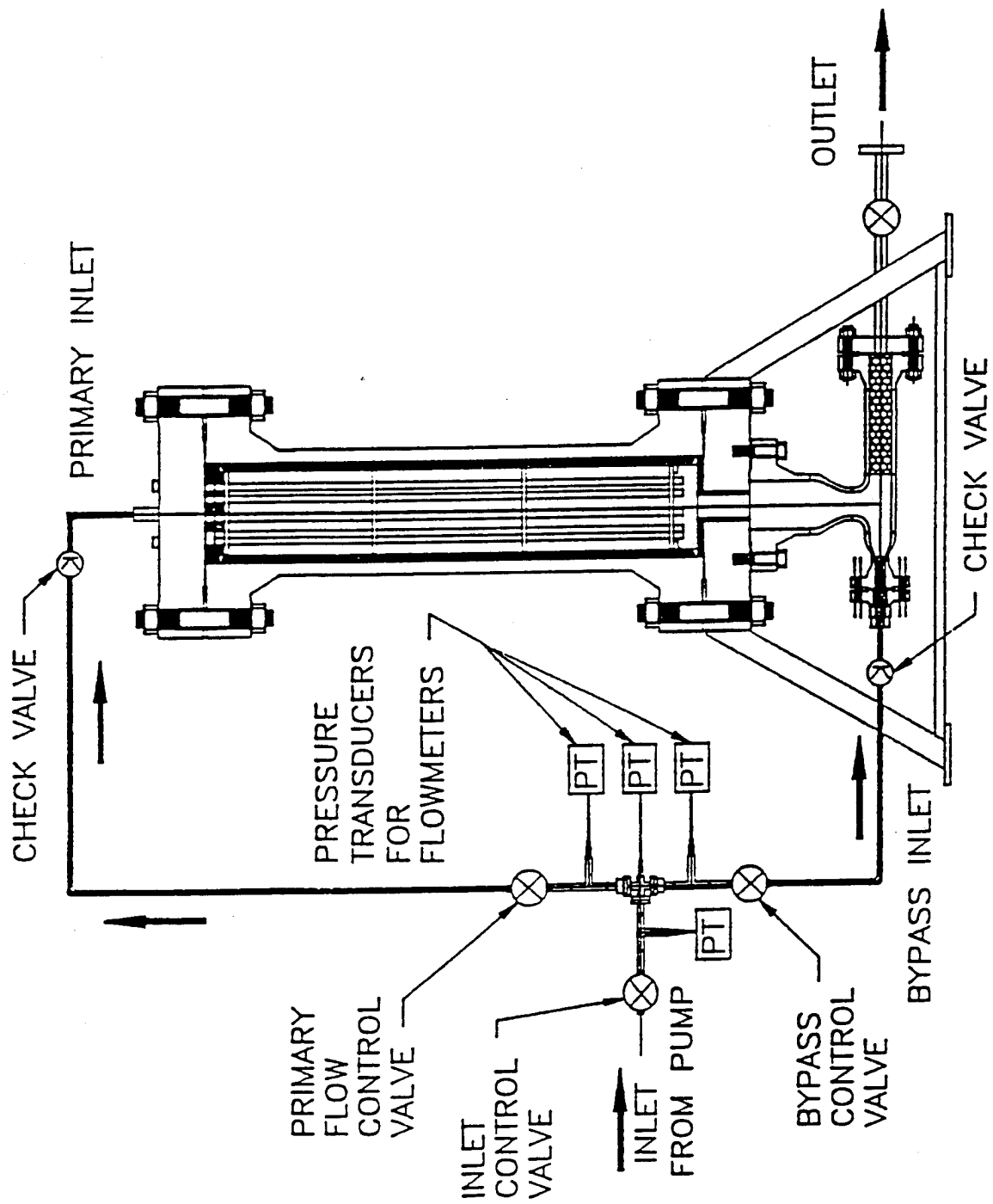

FIGURE 2. Pebble Bed Heater Schematic - Not the 1/6th Scale Design

Three phase 460 volt power is available at the PBH and 110 volt power is available throughout the test site. Space is available in the Test Bed control bunker to locate a Data Acquisition and Control System. An oxygen depletion alarm system is in place along with portable oxygen systems to prevent operator exposure to asphyxiation should a large nitrogen gas cloud form.

## **2.2 TVEF Design Requirements**

The TVEF must be located so as to not interfere with ongoing operations. Specifically, a keep out zone 6 m (20 ft) long was established at the Test Bed diaphragm area. The TVEF expansion tube is to be 30.5 m (100) feet long.

The driver is required to meet ASME Division II Boiler Code standards. Safety is a primary concern because people will be exposed to high pressure, high temperature piping and pressure vessels. The control bunker would afford only negligible protection if the heavy driver section failed.

The driver gas specifications are ambient to 126 atm (1850 psi) pressure and ambient to 644 °K (700 °F) temperature. Accuracy requirements are  $\pm 5$  percent on both temperature and pressure. The driver gas must be heated, the driver filled and the test conducted in a short enough time that the driver gas temperature does not decrease below the design point due to convective heat transfer to the driver wall.

The driver design thrust was originally 92,000 lbs. During preliminary design this design criteria was changed to 400,000 pounds to accommodate future expansion. The design crosswind criterion is 30 MPH.

Originally, the Army specified that the fill tube installation be designed in accordance with ANSI and/or ASME Boiler Code Division 2 piping standards. With Army approval SPARTA changed the design to be consistent with aircraft/missile design standards because the driver fill tube on the SPARTA pebble-bed heater was designed in this manner. ASME Boiler Code materials properties were used in the original fill tube design and were used in the design for the TVEF. The deviation takes place in the use of commercial Swagelock compression fittings in the original 8 ft driver facility

and the use of commercial stainless steel Parker-Hannafin flare fittings in the TVEF fill line. Swagelock has lowered the operating temperature of their presently manufactured fittings to a value which is unsuitable for this application.

The heavy wall SAE-4130 steel tubing and stainless steel Parker-Hannafin flare type fittings can be used to temperatures of 1,000° F. For temperatures above 1,000° F at pressures of interest, SPARTA believes that the fill lines must be redesigned in superalloy and special welded/screwed fittings must be designed.

The maximum TVEF fill temperature is presently structurally limited to 750° F by the pebble-bed mixer and the 2 inch diameter fill line.

### **2.3 Site Soil Properties**

The soil consists of 3 feet of sandy clay or silt overlying sandy silt with the water table at 3.5 to 5 feet (Reference 1). The coefficient of friction used during original shock tube design was 0.33 and a safety factor of 2 was recommended by the 1966 shock tube foundation design report (Reference 2). The maximum bearing pressure is 2600 psf for 1 inch settlement and a safety factor of 2 was recommended in the report.

### **3. CONCEPT TRADE STUDIES**

Design concepts were developed in accordance with the design requirements and trade studies were performed to select viable approaches. Early design studies examined issues which could be quickly resolved and therefore devote a majority of the resources toward fruitful design activities.

#### **3.1 Early Design Studies**

The use of an existing diesel engine mount as part of the thrust reaction mass was quickly discarded. Examination and calculation showed that its use was not feasible because:

- The number of reinforcing bars is negligible and the concrete would probably break up under the shock loading experienced in responding to the thrust of a driver.
- The rebars that are in place according to available data are longitudinal with no provision for transverse loads.
- The stability of the block was insufficient to prevent rollover due to transverse loads and the transverse load would cause allowable soil pressure to be exceeded resulting in motion and sinking of the block.

SPARTA examined the existing TVEF shock tube driver and recommended that the driver be disassembled, refurbished, reassembled with new spiral wound 316 stainless steel seals, hydrotested and recertified in accordance with the ASME Boiler Code. After passing the ASME hydrotest, the driver should be coated with protective marine environment paint on all exterior exposed surfaces. The interior should be protected with nickel plating, phosphate or high temperature primer and paint. It is probable that corroded sealing surfaces will require machining and the interior will require grit blasting. If the driver bolts and nuts cannot be identified as having the proper strength and being made of approved materials, they should be replaced with proper fasteners.

Use of the existing expansion tube sections was discarded because of their poor physical condition (rusted throughout), because the rust would have to

be removed in order to weld stiffeners onto the exterior and because they can be replaced with more substantial sections relatively inexpensively.

Alternate siting arrangements were studied for a concrete pad supported facility. A location next to the Test Bed was selected on the basis of convenience and affordability.

The existing LN<sub>2</sub>/Pebble Bed Heater gas supply system was found to be easily capable of meeting the TVEF requirements. Also, a single heated gas supply system arrangement was found to be compatible with each of the candidate facility configurations and is described in Section 4.1.2.

### **3.2 Alternate Facility Configurations**

Five basic facility configurations were examined during the concept phase. Sufficient engineering design analyses were performed to establish feasibility, to size the structures and to differentiate their costs and operational features. A configuration designed to accommodate the original axial thrust requirement is designated as a 100,000 lb design and a configuration sized to meet the final, expanded capability is designated as a 400,000 lb design.

#### **3.2.1 100,000 lb Pad Supported Concept**

The TVEF driver tube and expansion tube will be mounted on a reinforced concrete support structure with integral tie down rails (Figure 3). A steel driver support truss transfers the axial thrust to the 3000 psi concrete reaction pier; the pier is 70 feet long by 8 feet wide and the shear keys are 5 feet deep. A sliding expansion tube section allows access to the throat valve test section and a steel thrust stand accommodates the (small) expansion tube thrust load. Commercially available rollers with height adjustment bolts support the driver and the expansion tube.

A smaller free standing concrete pier is used to support the aft end of the expansion tube. This pier takes only vertical load.

The expansion tube is a 1/4 inch wall low carbon steel 30 inch diameter tube. Two axial opposing WF beams welded to the sides increase its

bending stiffness so that only two expansion tube supports are required.

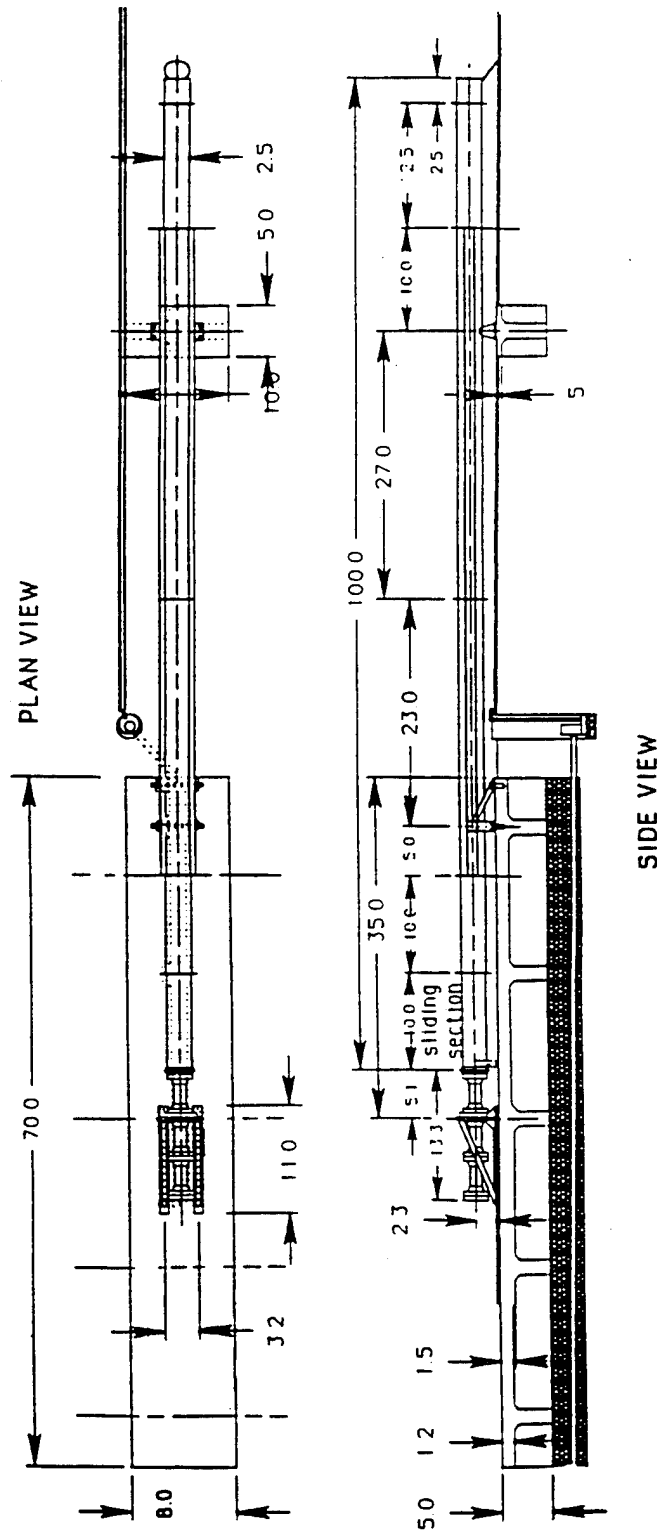

Figure 3 100,000 LB Pad Supported Concept

The tube is also reinforced with spaced circular rings to prevent local crippling due to bending. Free thermal expansion is enabled by axial sliding bearings installed on the aft mount.

### **3.2.2 100,000 lb Piggyback Concept**

Recognizing that the cost and excavation for a new facility could present problems, SPARTA prepared an alternate design concept which piggy backs on the existing Eight Foot Shock Tube. The estimated costs are significantly lower than for the baseline design concept since no reaction pad and no new excavation is required.

The TVEF driver and expansion tube are mounted on top of the existing Eight Foot Shock Tube (Figure 4). Steel trusses transfer the driver thrust axial load to the shock tube walls fore and aft of the primary reaction pier; a smaller truss work transfers the expansion tube axial load to the Eight Foot Shock Tube wall forward of the shock tube test section. The TVEF driver and expansion tube are mounted on roller bearings as in the baseline design and the bearings are supported by steel truss works welded to the shock tube walls. A steel framework secures the end of the TVEF expansion tube.

The expansion tube would be sectioned and fitted with a strong back so that the portion over the shock tube test section can be lifted out to clear the area. Because the TVEF will be about 17 feet above the ground, standard mobile work platforms would be used for access (Figure 5).

### **3.2.3 100,000 lb Side by Side Concept**

To avoid having operating personnel working on an elevated facility, Sparta designed a 100,000 lb rated TVEF driver/expansion unit to be installed on the side of the 8 ft diameter shock tube (Figure 6). The centerline of the side mounted TVEF was approximately 4 ft off the ground for ease of access without ladders and stools. The design kept clear a 20 ft wide access way to the 8 ft shock tube nozzle area.

A horizontal steel truss mounted on the 8 ft shock tube reaction block supported the TVEF driver and expansion tube and transferred thrust and moments directly to the reaction block of the 8 ft diameter shock tube.

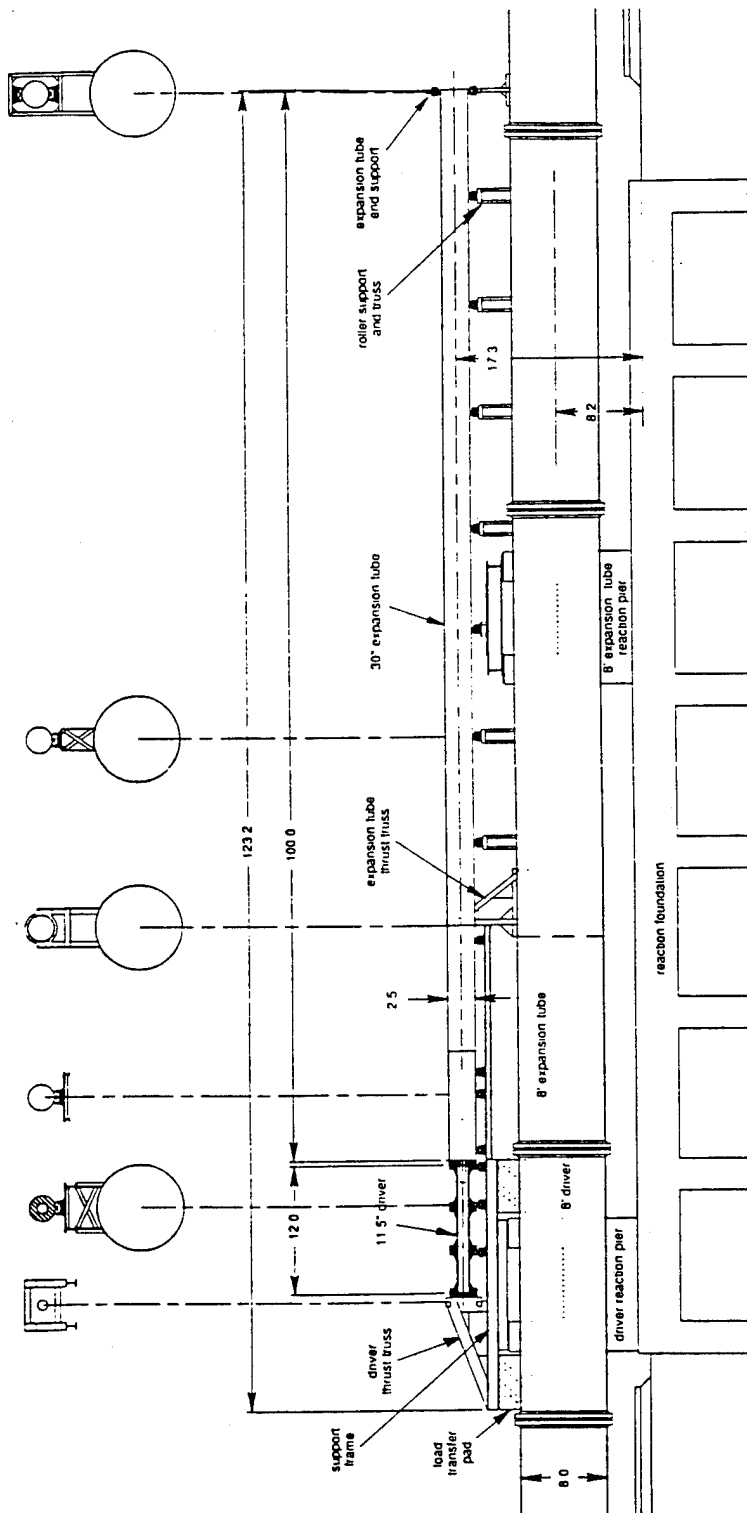

Figure 4 100,000 LB Piggy Back Concept

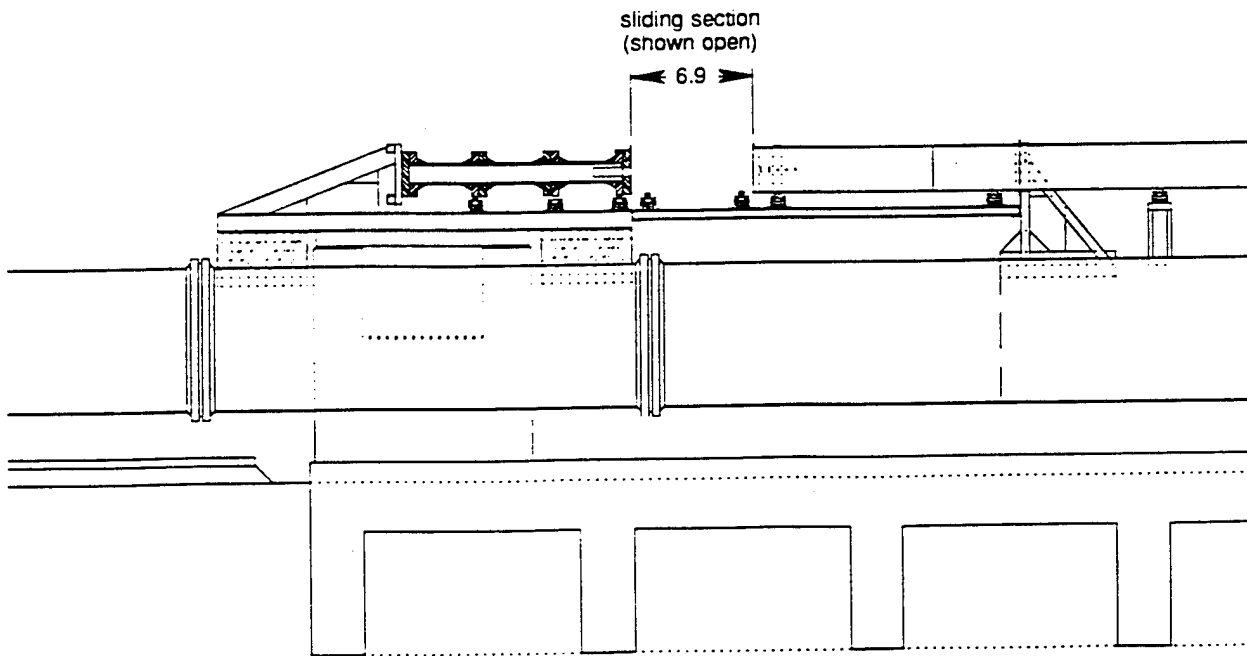
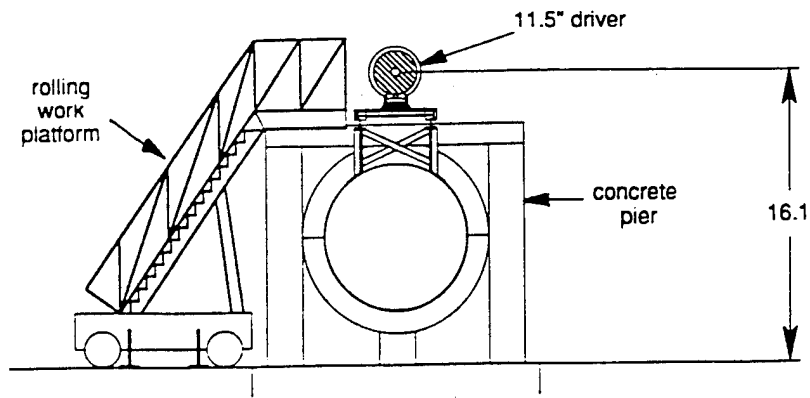

Figure 5. Mobile Work Platform and Sliding Expansion Tube Detail



### **3.2.4 100,000 lb Upgradable Pad Concept**

Consideration was given to building a 100,000 lb pad which would be upgradable to a 400,000 lb pad at a later date (Figure 7). Significant complexity and cost is required to do this. Specifically:

- 400,000 lb thrust reaction rails are integrated with the 100,000 lb reaction rails
- the concrete pad width is increased to 10 feet to accommodate the 400,000 lb rails
- the concrete pad shear keys are increased to 6 foot deep
- 400,000 lb pier rebar patterns are added to the 100,000 lb pad envelope, bent 90 degrees at the pad sides and ends and covered with a six inch concrete layer which would be removed when the expansion construction took place.

The balance of the 100,000 lb pad supported concept remained the same.

### **3.2.5 400,000 lb Pad Supported Concept**

The final candidate configuration assumed that the 400,000 lb pad would simply be built now to accommodate both facilities. Further concrete pad design optimization produced a 15 foot wide by 85 foot long concrete pad (Figure 8) which allowed the reduction of the number of shear keys from 7 to 6. In addition, it is no longer necessary to re-excavate, remove the concrete facing from the pad sides and ends, construct forms, extend the rebar and concrete pad, backfill and remove debris.

The balance of the design remained the same the same as the 100,000 lb upgradable design.

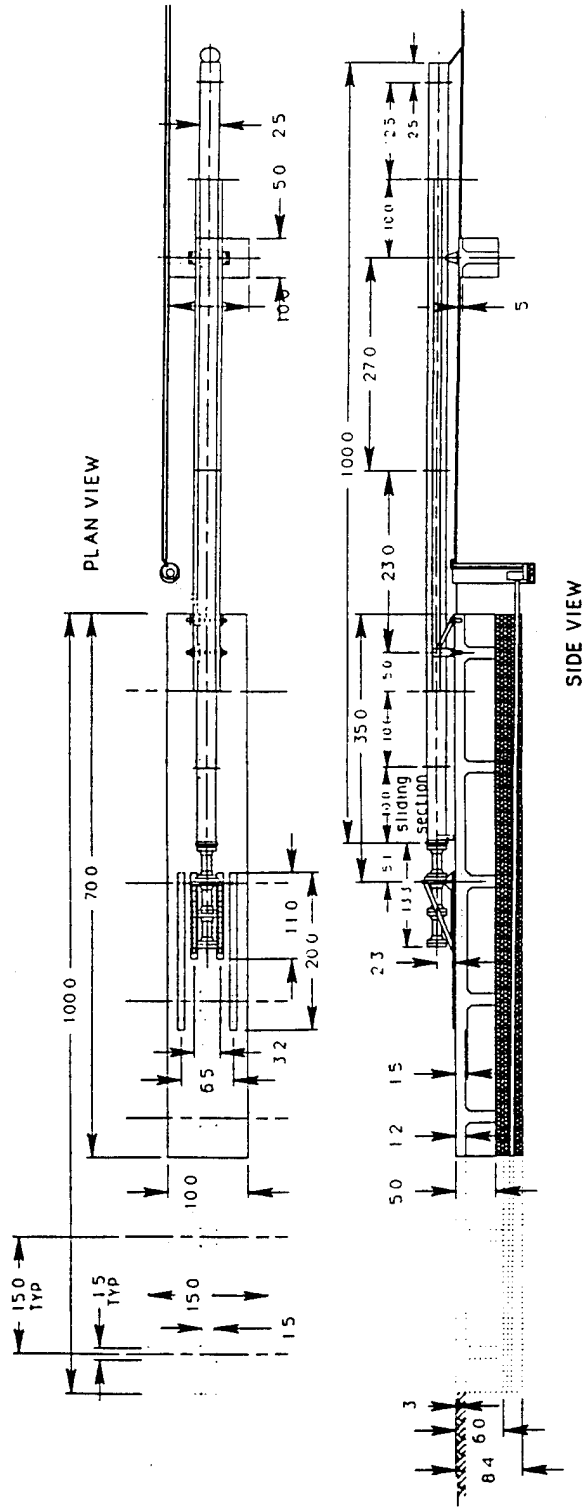

Figure 7. Upgradable 100,000 LB Pad Supported Concept

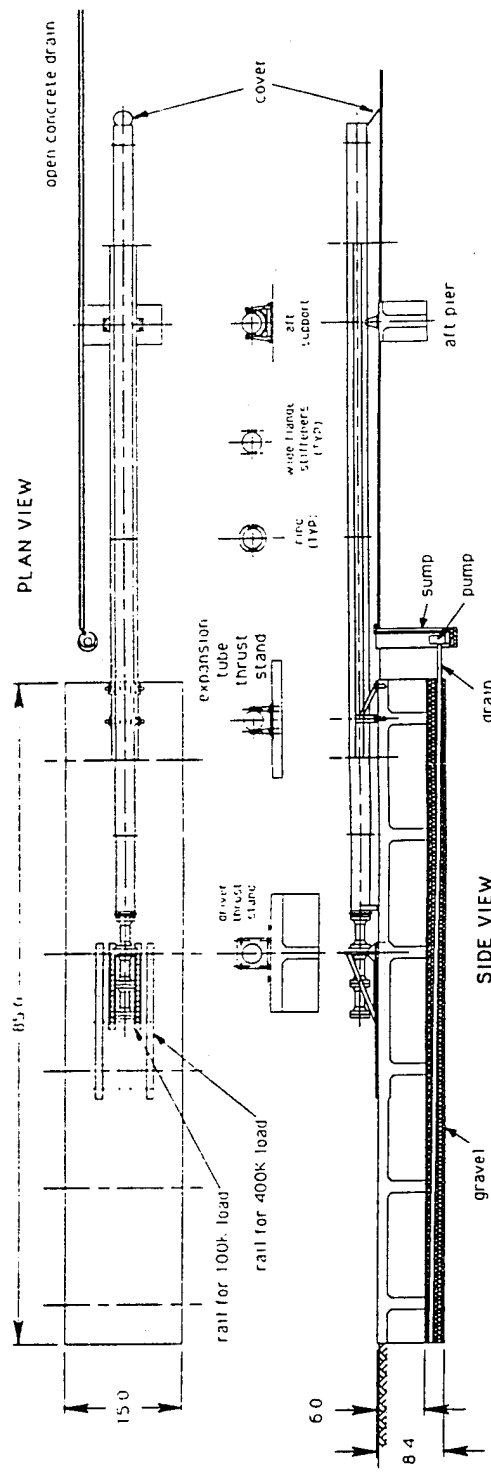

Figure 8. 400,000 LB Pad Supported Concept

### 3.3 Concept Selection

All of the concept configurations were judged to be feasible and can be constructed in approximately the same time frame. Concept selection was made in the following fashion:

- The 100,000 lb pad supported concept was eliminated because of the desire to expand the facility at a later date.
- The piggyback concept was eliminated because of excessive interference with existing operations and because of a desire not to expose workers to unnecessary risks by operating at 16 foot heights.
- The side by side concept was eliminated because expansion to a 400,000 lb capability was considered dubious.

This left a choice of building an upgradable 100,000 lb pad supported design or building a 400,000 lb pad supported design now.

Consultation with a Professional Civil Engineer produced estimates that 30 percent of the cost of the reinforced concrete support pad could be saved if the 400,000 lb pad were simply built now. Further, construction of the upgrade to the 100,000 lb reaction pad would result in significant down time for the facility. Therefore, SPARTA recommended building the 400,000 lb pad now. Army Research Laboratory personnel agreed with SPARTA's recommendation and directed that engineering design activities proceed with the 400,000 lb concept.

## **4. ENGINEERING DESIGN**

Preliminary engineering designs were developed for the site layout and the components of the 400,000 lb pad supported concept. A facility design description is provided here along with installation and operation procedures.

### **4.1 Facility Design**

Engineering design calculations are summarized in Appendix A and the heat transfer models used to size valves and develop operating procedures are documented in Appendix B.

#### **4.1.1 Site Plan**

The TVEF will be located in close proximity to the 1/6th Scale Test Bed (also referred to as the Eight Foot Shock Tube). The shock tube is oriented at an angle 71 degrees clockwise from north. Essentially all of the building fronts, sidewalks, roads and installations are parallel to this direction.

#### **Existing Features**

The diaphragm changing/compressor building is approximately 41 feet from the centerline of the 8 ft diameter shock tube. Electrical power for the gas supply system originates in this building. The control bunker is adjacent to the diaphragm changing/compressor building and east of it. The bunker houses the test personnel, test data acquisition systems, valve controls systems and power switching. An unused diesel engine mount east of the bunker is oriented orthogonal to the 8 ft diameter shock tube; a wooden foot bridge spans the diesel engine mount in line with a sidewalk leading to the diaphragm changing/compressor building.

The Test Bed heated driver gas supply system is located near the downstream end of the driver. Included are the Pebble Bed Heater (PBH), the cryogenic pump, the liquid nitrogen cryogenic storage tank and the gas supply electrical control boxes. A 2 inch O.D. line transfers heated gas to the test bed driver. The cryogenic pump is a constant displacement pump

which has a rated capacity of 1.6 kgm/s (32 GPM). The PBH is preheated by electrical resistance heaters using 460 volt, three phase power drawing a maximum of 324 amps (150 Kw) plus 30 amps at 120 volts for switching (4 Kw); the cryogenic pump draws a maximum of 105 amps (48 Kw). A switching system prevents the PBH and pump from being operated simultaneously.

A sump and sump pump used for draining the foundation of the existing shock tube is located behind the liquid nitrogen storage tank and a runoff drainage ditch is located in front of the diaphragm change building and bunker. Left over concrete piers from earlier diesel engine tests must be removed.

### **TVEF Features**

The TVEF driver will be mounted on a reinforced concrete pad via rails embedded in the concrete. Two sets of rails are provided, one for the present 100,000 lb thrust requirement and one for the future 400,000 lb thrust requirement. The expansion tube will be mounted on the pad at the upstream end and on an a support pier on the downstream end. The TVEF reinforced concrete base will be alongside and parallel to the existing shock tube and approximately twenty feet east of the driver flange. The shock tube and ancillary buildings will not be affected by the TVEF installation other than replacing underground electrical conduits which will be severed while excavating for concrete forms. The TVEF driver is located east of the control bunker so that radially expelled debris will not enter the building (in the event of driver structural failure). When completed, the TVEF concrete base will provide a smooth walkway for personnel.

The TVEF will have a drainage system connected to the existing sump from which the drainage will be pumped to a field north of the shock tube.

The TVEF will be pressurized by the existing Test Bed gas supply system via a new heated gas transfer line. A new 3 way manual valve will be installed in the present Test Bed fill line to provide safe, positive control of the heated gas transfer process. The TVEF driver gas transfer line will be electrically heated with the 460 volt, three phase power coming from the PBH power line. A vent valve located at the upstream end of the TVEF

driver will be used to control the driver pressure; exhaust gas will exit via a 10 foot tall exhaust stack.

A remote Data Acquisition and Control System (DACS) will be located near the driver to keep instrumentation lines short. Facility control and data processing will be provided by a PC located in the bunker. Communication between the DACS and the PC is via 150 feet of interface cable protected by six inch diameter Schedule 80 PVC pipe.

#### **4.1.2 Pier, Driver and Expansion Tube Overall Views (TVEF-1.1)**

A 12 feet wide by 93 feet long reinforced concrete reaction pad supports the 6 ton TVEF driver and one end of the 7 ton expansion tube assembly and reacts 400,000 lbs of axial thrust. Six transverse shear keys and a single vertical stem with footings on each were sized to transfer the loads to the soil and to resist bending moments. The footings were added to the original concept designs because it is assumed that excavation and forming is required; therefore, footings are used to provide additional shear area for transferring thrust loads to the soil, additional compression area for negative moments and additional area for steel rebar to resist positive moments at the most effective location.

The 3000 psi concrete pad is heavily reinforced with A-615 grade 40 steel re-bars oriented to distribute shear key and thrust loads into the concrete mass. A system of steel tee sections is cast into the concrete to accommodate expected driver/expansion tube configurations.

A porous gravel bed is installed under the central spine of the reaction pad. It runs the full length of the reaction pad and encloses a 4 inch diameter perforated drain pipe. The perforated drain pipe slopes downward from the exhaust direction of the expansion tube to the upstream end of the driver and pipes drainage into a vertical sump formed from 30 inch diameter concrete pipe. A submersible float actuated electric sump pump is used to pump accumulated water through an underground pvc pipe to the existing Test Bed sump.

A 9 foot wide by 5 foot long free standing reinforced concrete pier similar to the main reaction pier is used to support the aft end of the expansion tube.

The pier takes loads only in a transverse vertical plane as the expansion tube is allowed to slip axially. Provision is made to shim and re-position the expansion tube if earth movement takes place over time. The expansion tube aft mount restrains the tube about a vertical plane but allows free thermal expansion in the axial direction. The aft mount is fabricated by welding from low carbon steel plate and painted with marine paint after completion.

#### **4.1.2.1 Concrete & Rails**

The reaction pad concrete slab and the vertical keel are 16 inches thick; the transverse shear keys are 18 inches thick. The footings are 12 inches thick by 36 inches wide. Steel re-bars (#6 except where noted) are preformed and inserted into the concrete forms prior to filling with concrete. The re-bar pattern is as follows:

**Top Slab:**

Longitudinal Bars on 8 inch centers (top layer #8)  
Transverse Bars on 10 inch centers

**Transverse Keys:**

Transverse Bars on 8 inch centers  
Vertical Bars on 8 inch centers

**Longitudinal Stem:**

Vertical Bars (#4) on 10 inch centers  
Longitudinal Bars (#4) on 8 inch centers

**Longitudinal Footing:**

Six #11 Bars

After most of the re-bars are in place, the driver reaction rails are aligned and installed, the expansion tube reaction rails are aligned and installed and the remaining re-bars are threaded through the rails and installed.

The driver and expansion tube thrust stand consist of four 18 foot long WT 13.5x47 T section rails held in place by two 2 inch diameter crossbars. Thirty six headed studs 0.5 x 6 inches anchor each rail to the concrete;

eighteen 1 1/4 inch holes allow the rebars to pass through each rail. Twelve 1 1/2 inch holes are drilled into each of the inner rails to accommodate the driver and expansion tube thrust stand.

The expansion tube end support concrete form is a 16 inch thick horizontal top slab over two 12 inch orthogonal vertical keys along with 12 inch thick footings. Rebar are on 1 foot centers in single curtains.

#### **4.1.2.2 Expansion Tube, Supports, Rings & Longerons (TVEF-1.1.2)**

The expansion tube is a 1/4 inch thick low carbon steel 30 inch diameter tube welded on opposing sides to two axial opposing WF beams which increase its bending stiffness (see recommendation to minimize stiffener length) so that only two expansion tube supports are required. The tube is also reinforced with spaced circular rings to prevent local crippling due to bending. Free thermal expansion is enabled by axial sliding bearings installed on the aft mount. The assembly has a 6 ft long, 30 inch diameter removable section along with a 5 ft long, 28 inch diameter sliding section on the upstream end to allow access to the TVEF test valve. The expansion tube assembly will be hot galvanized at the factory except for the local areas to be welded in the field. These welds will be protected with cold galvanize.

The 30 inch diameter, 100 ft long expansion tube assembly is fastened to the inboard pair of the four aft reaction rails embedded in the concrete base pad. The aft end of the expansion tube assembly is fastened to a sliding support mounted to the aft concrete support pedestal.

#### **4.1.2.3 Driver Thrust Frame (TVEF 1.1.3)**

The TVEF driver thrust stand is a welded triangular steel trusswork supporting a six inch thick vertical steel plate. This plate is bored out to 30 inch diameter so as to accommodate the 29 1/2 inch diameter driver flanges. The driver is bolted to the thrust stand through a central spacer plate which is bored out to 11 1/2 inches. The spacer plate/flange joint is sealed with the same type gasket presently used. The thrust stand is bolted to the reaction rails with specified torques. After assembly, SPARTA has recommended that the installer paint all bolts, washers, exposed threads and nuts with rust inhibiting paint and plug all holes in the driver.

### 4.1.3 Driver Gas Supply System (TVEF-1.2)

Heated Nitrogen gas will be pumped from the Pebble Bed Heater to the TVEF driver through 100 feet of 1.5 inch I.D./0.188 inch wall SAE 4130 alloy steel tubing. A three way 2500 lb Globe valve is fitted into the Test Bed fill line. On one position, this valve allows full flow to the Test Bed driver and shuts off flow to the TVEF. When switched to the alternate position, this valve shunts the full flow to the TVEF and shuts off flow to the large driver. The valve is rated at 1,850 psig at a temperature of 1,000° F.

If the fill tube temperature is substantially less than the gas temperature, the gas will lose significant thermal energy through convective heat transfer to the tube wall. Driver inlet gas temperatures were calculated using the heat transfer model described in Appendix B.1; initial tube wall temperatures of 300 K and 450 K were considered. In neither case did the gas temperature reach the desired inlet temperature of 650 K in the proposed TVEF driver filling time of several tens of seconds (Figure 9). Further, 63 percent and 38 percent of the gas thermal energy was lost to the tube wall respectively during the calculated times. Therefore, the fill tube wall will be pre-heated to the desired inlet gas temperature.

The fill tube is heated by a pair of resistance strip heaters that are fastened to opposing sides of the fill tube by a series of stainless steel clamps. The strip heaters come in 50 ft lengths which are controlled by an individual power supply/controller. Thermocouples spaced at 10 ft intervals feed back temperature data to the controller. Heater power is taken directly from the main pebble-bed power supply.

The fill tube assembly including heater strips and fittings is insulated by preformed cylindrical foamglass insulation. This insulation was chosen because it is impervious to moisture and prevents corrosion of stainless steel fittings exposed to salt air from the nearby Chesapeake Bay. The preformed insulation blocks are cemented together by high temperature cement and are covered with a stainless steel protective covering. The outer covering is cemented in place and all joints are sealed. During the TVEF fill process, the exterior surface temperature of the fill pipe will not pose a safety hazard. Substantial thermal energy remains in the fill tube which will diffuse to the surface but the temperature is not expected to be high.

# FILL GAS EXIT TEMPERATURE

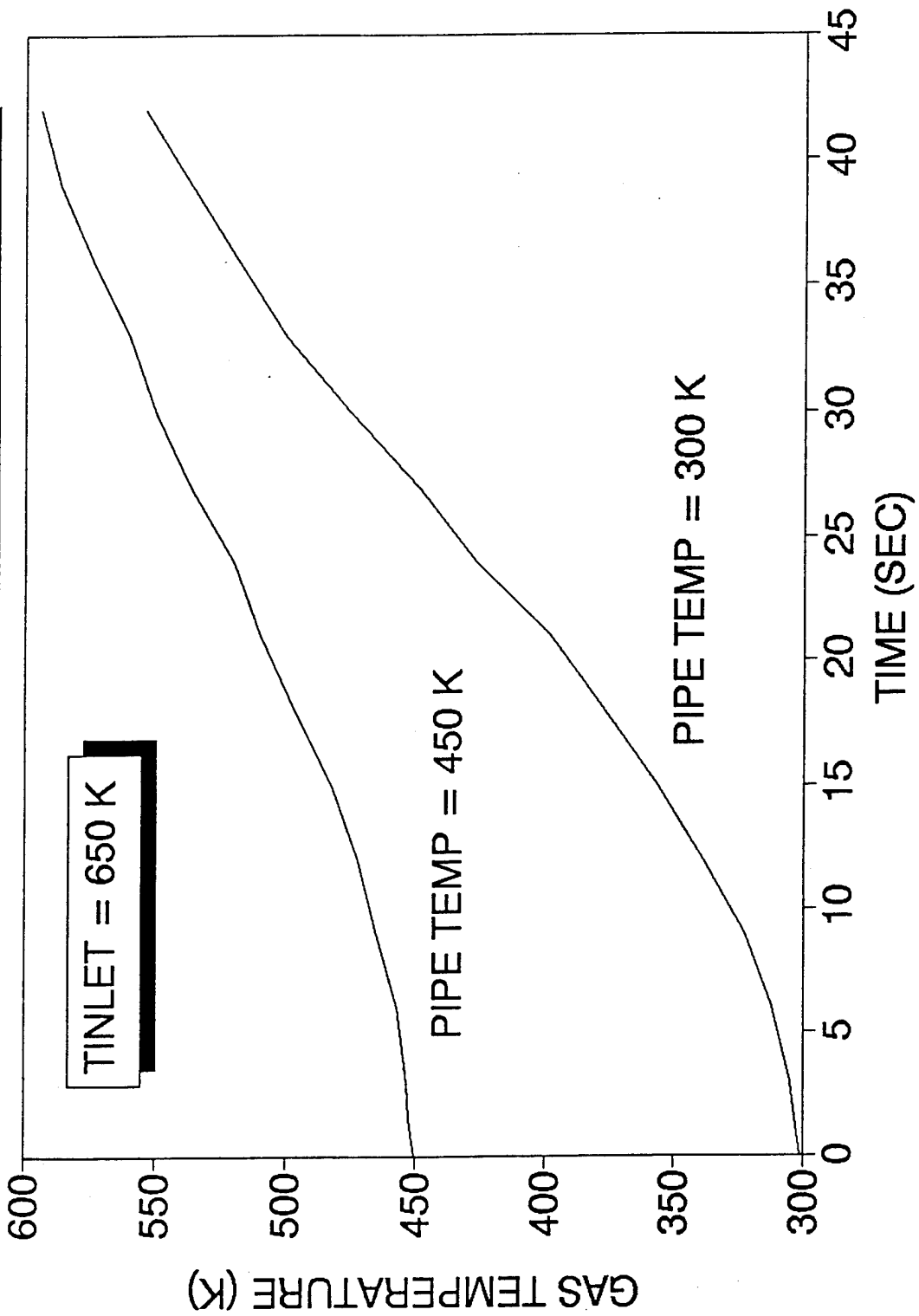

9/29/93

Figure 9. Effect of Fill Tube Heating on Driver Gas Inlet Temperature

A 1 1/2 inch remotely controlled vent valve is added to the upstream end of the TVEF driver to control the driver pressure during operation and to provide a method of bleeding down the driver gas if a throat valve malfunction occurs. The pneumatic control valve is operated by a solenoid valve which energizes a diaphragm operator which in turn actuates the valve pintle on command. The solenoid valve will be operated by a 28 VDC signal from the control system in the bunker. The vent valve pneumatic control gas supply consists of a 2200 psi nitrogen storage bottle connected to a two stage Airco regulator which reduces the input pressure to approximately 40 psig. In parallel with the solenoid valve is a small accumulator which furnishes required high flow rates upon demand independent of the supply line and regulator size. A bleed valve vents the pneumatic control system when it is shut down.

Connected in series with the vent valve is a variable area manual ball valve which provides a adjustable orifice in the vent line to tune the system for various test conditions. Operating procedures are described in section 4.3. A 1900 psig pressure relief valve assures that the driver will not be overpressurized.

The exhaust from an open vent valve would be very noisy and is potentially hazardous so the flow is directed into a vertical 6 inch diameter exhaust stack approximately 10 feet high. The upper two feet of the steel pipe are perforated with 1/8 th inch diameter drilled holes which reduce the noise signature. Each end of the pipe is capped and a single 1/8 th inch diameter drilled hole in the stack bottom drains condensate. The exhaust stack and transfer line are electroless nickel plated during fabrication.

#### **4.1.4 Electrical Power System (TVEF-1.3)**

In the present 1/6th Scale Test Bed, 460 volt 3 phase power is provided to the Pebble Bed Heater (PBH) and cryogenic pump via underground cable directly from the compressor building. A four way switch in the control bunker selects between AIR/PBH/LN/OFF but the power still routes through the compressor building. A 3 phase power junction box is located on the Test Bed concrete apron directly across from the compressor building.

460 volt 3 phase power from the junction box goes to a switch box with 200

amp circuit breakers and a lockable manual lever arm. Power lines exiting the switch box go to the heater rod power distribution box. PBH heater elements are thermostatically controlled from a control box located in front of the PBH and can be individually switched out by setting a low set point temperature. 460 volt 3 phase power also goes from the junction box to a separate manual switch box and on to the control box located in front of the cryogenic pump.

110 volt single phase power from a junction box located directly across from the control bunker provides control system power to the remote valves. Instrumentation lines are routed through a conduit parallel to the 110 volt power line conduit. These two conduits will be disrupted during TVEF construction.

460 volt 3 phase power will be tapped off of the PBH power circuit after the manual switch box and into the fill tube heater system control box. Thus, the fill tube heaters will be switched off when the pump is switched in. In the switch box the power is stepped down to 240 volts and routed to two heater control units each of which supply power to two 50 foot long tube heating units. Five thermostat circuits provide distributed temperature control for each tube heater unit. The desired fill tube temperature is manually set in the heater control units and left on throughout.

#### **4.1.5 Instrumentation and Control System (TVEF-1.3)**

Facility instrumentation will include 12 thermocouples, 1 pressure gauge and one valve position indicator. The thermocouples are chromel alumel with a 1/8th inch sheath and have time constant less than 0.1 seconds. The pressure transducer is a strain gauge type with an accuracy of  $\pm 0.2$  percent of span; the transducer will be mounted at the end of a standoff tube to isolate its face from the hot driver gas. Limit switches indicate whether the vent valve is open or closed. A sealed six inch Schedule 80 PVC conduit will carry instrumentation and control lines from the TVEF to the control bunker. This prevents damage to the lines and wires by weather, by people and by vehicles. The conduit enters the control bunker through an existing port on the north wall.

TVEF operation requires a PC based Data Acquisition and Control System;

a remote DACS will be located at the TVEF facility to keep instrumentation lines short whereas the PC will be located in the control bunker approximately 50 feet away. The DACS contains 12 bit D/A and A/D boards, a 16 channel thermocouple board, a power supply and the communication boards. The PC is a 33 Mhz 486 system with 4 MB of RAM, a 170 MB hard drive and six 16 bit ISA expansion slots. The Paragon Control Software package already in use for the Test Bed will be adapted to control the TVEF as well. The PC will be used to input the driver pressure set point to open the vent valve (a manual override provides backup) and to record and display process valve position, gas pressure and gas temperature. A data sampling rate of 10 Hz is more than adequate to capture the TVEF filling process time history. Digital readout process indicators will display the driver gas temperature and pressure for operator convenience.

## **4.2 Facility Installation**

Initially, the site is excavated as necessary, forms are installed, re-bars are placed, severed cable ways replaced, and the reinforced concrete pad poured. After the concrete has cured for 30 days, the following assembly steps are taken:

1. The TVEF driver thrust stand is bolted to the reaction rails with code specified (e.g., 1000 ft lb) torques. All bolts, washers, exposed threads and nuts are painted with rust inhibiting paint.
2. The hydrotested TVEF driver assembly including seals, spacer plate and end flanges is bolted to the TVEF driver thrust stand. All bolts, washers, exposed threads and nuts are painted with rust inhibiting paint.
3. The expansion tube (with sliding section installed) is aligned with the TVEF driver and bolted to the concrete pad and aft support pad. All bolts, washers, exposed threads and nuts are painted with rust inhibiting paint.
4. The vent valve system is installed on the forward driver header and connected to its pneumatic power supply and electrical

power supply. All bolts, washers, exposed threads and nuts are painted with rust inhibiting paint.

5. The existing 2 inch diameter Test Bed driver fill line is cut and a the manual 2 inch three way valve is installed so that flow can be diverted to the TVEF as required.
6. A 2 inch to 1.5 inch reducer is installed in one port of the 3 way valve and the 1.5 inch line is connected to the TVEF driver using the proper fittings.
7. Strip heaters are fitted to the 1.5 inch tube and fitting assembly using stainless steel hose clamps.
8. The strip heaters are wired to their control boxes and thermocouples are installed every ten feet on the fill line with connections to the control boxes.
9. The strip heater control boxes are wired to the pebble-bed heater power supply.
10. The fill tube insulation is installed after checkout of the strip heater system.
11. Scientific instrumentation is installed on the fill line, driver and valves. Transmission lines to the PC in the control bunker are installed and all ground leads are connected to an approved grounding stake.
12. Ground fault interrupter circuit breakers are installed on all primary power leads connected to the TVEF system.
13. Covered tapered wooden cable crossovers are installed to protect all top of slab wiring from contact with people, equipment and vehicles.

### 4.3 Facility Operation

As heated nitrogen gas is pumped into the TVEF driver, the gas temperature is increased by compression heating but is simultaneously decreased by heat transfer to the driver wall and by driver venting. The driver gas filling process was analyzed using the thermodynamic and heat transfer model found in Appendix B.2. Procedures described here are for the maximum driver gas test condition of 644 °K temperature and 118 atmospheres pressure (referred to as Test Point 7).

The existing ARL 1/6th Scale Test Bed gas supply system is capable of delivering 1.6 kgm/sec (32 GPM) of heated gas to the TVEF driver. However, because of the TVEF driver's relatively small volume, the driver would be filled in times on the order of 5 to 7 seconds if there were no heat transfer to the driver walls (Figure 10). Halving the flow rate doubles the driver fill time to 10 to 14 seconds and reducing the flowrate by a factor of 4 brings the fill time up to 20 to 30 seconds. For practical operating control, a flow rate of 0.8 kgm/sec (16 GPM) is chosen.

Even at times as short as a few tens of seconds, heat transfer to the wall has a significant effect on driver gas filling (Figure 11). Approximately 5 additional seconds are required to fill the driver to Test Point 7 (118 atm pressure) and the driver gas temperature is several hundred degrees K cooler than it would have been without heat transfer. At 0.8 kgm/sec of 675 °K gas, the driver fill time is about 17 seconds when convective heat transfer is included in the analysis.

If the driver filling process were to continue, the pressure in the driver would continue to build linearly. Terminating the driver filling is not an acceptable solution because the driver temperature and pressure drop rapidly providing a few second test window (Figure 12). Venting the driver gas through a constant vent valve area of  $3.3E-5 \text{ m}^2$  (1/4 inch diameter port) provides the required Test Point 7 driver gas conditions for a reasonable test period (Figure 13). The adjustable area manual vent valve provides the capability to achieve intermediate driver gas test conditions without an elaborate and expensive feedback control system.

# TVEF DRIVER FILLING ESTIMATE

NO HEAT LOSS

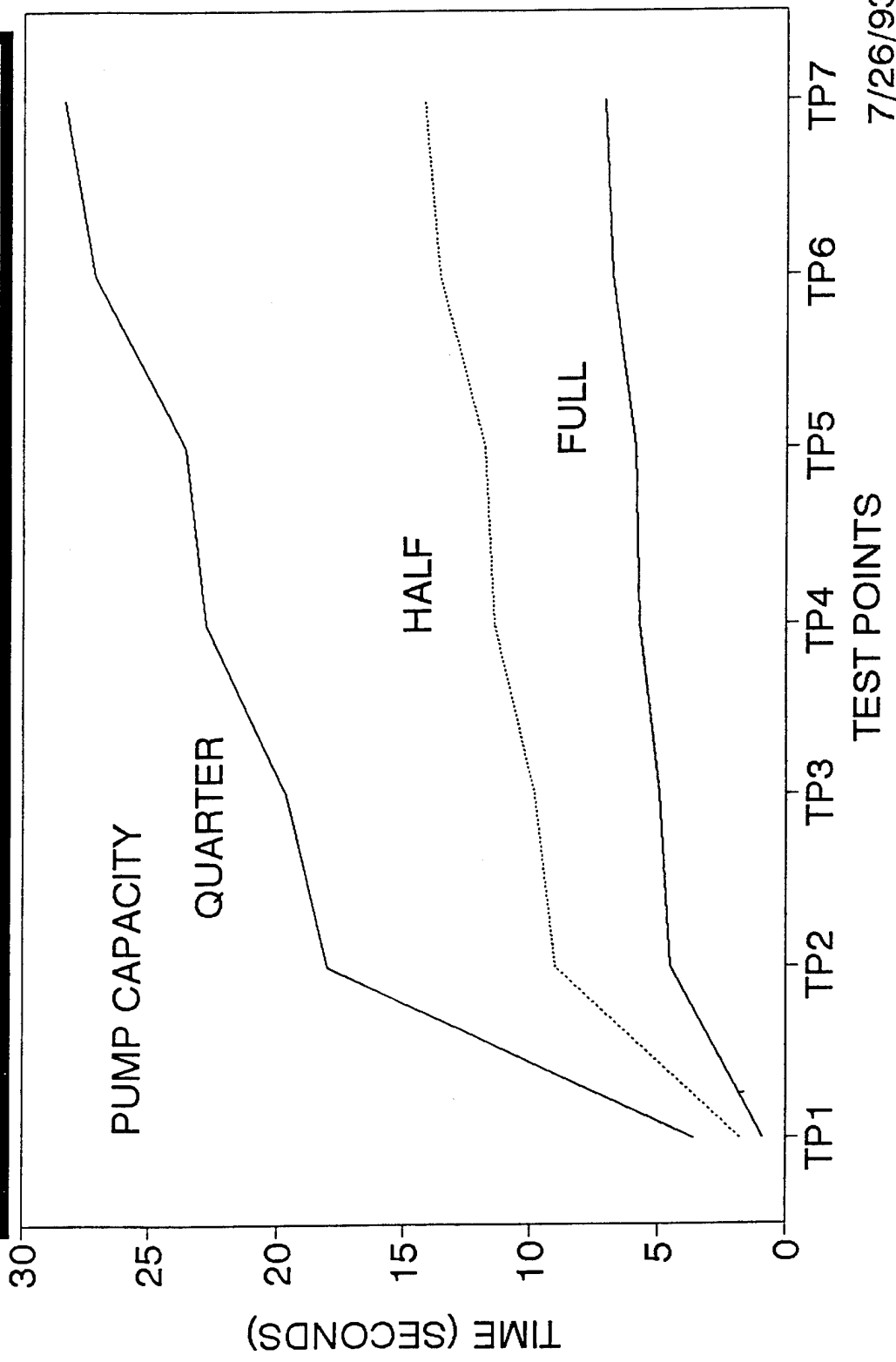

7/26/93

Figure 10. Estimate of TVEF Driver Gas Fill Time

# TVEF DRIVER GAS

EFFECT OF HEAT LOSS - TP7

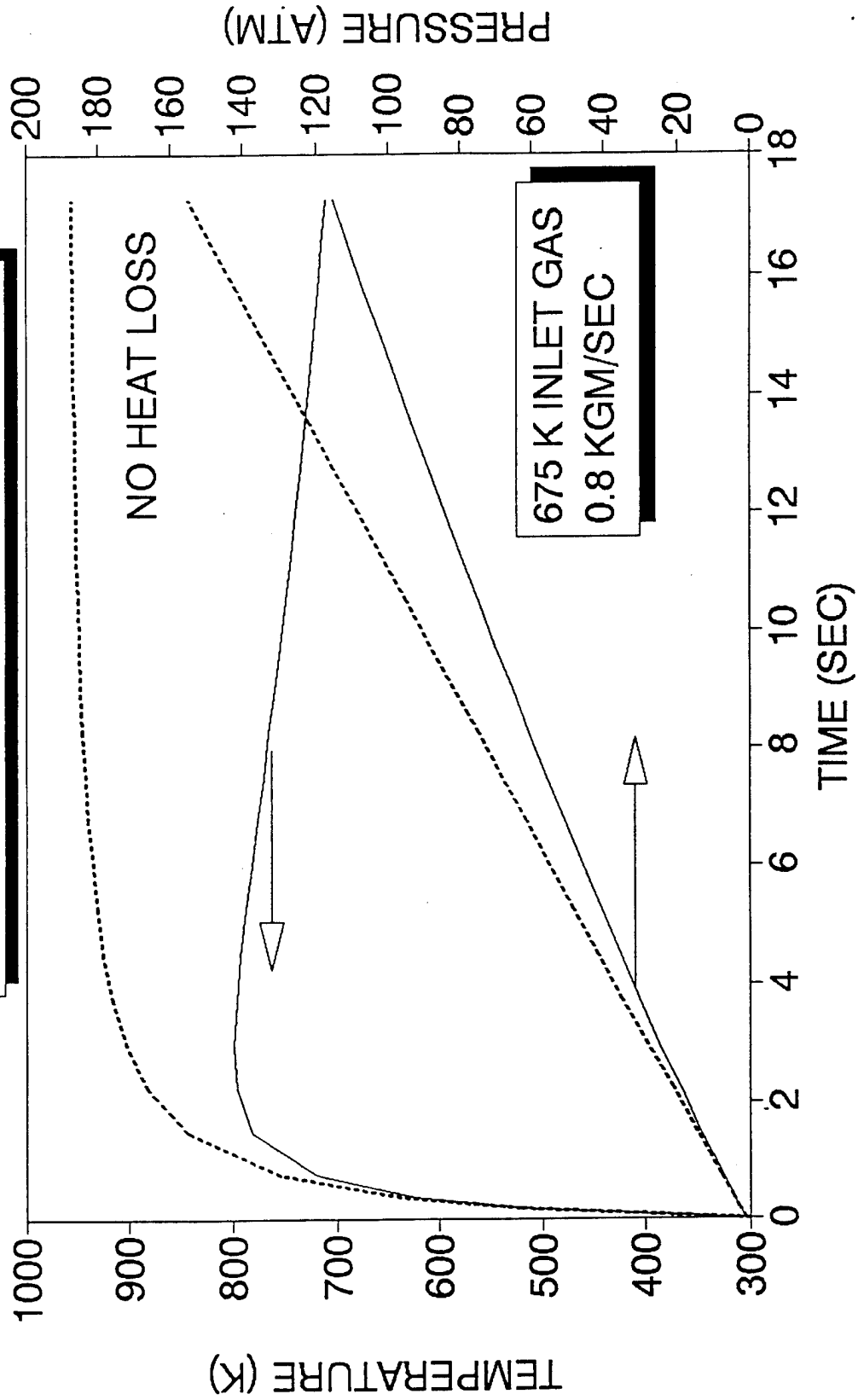

10/15/93

Figure 11. Effect of Heat Transfer to the Driver Wall

# TVEF DRIVER GAS

INFLOW 0.8 KG/M/SEC STOPPED AT FILL

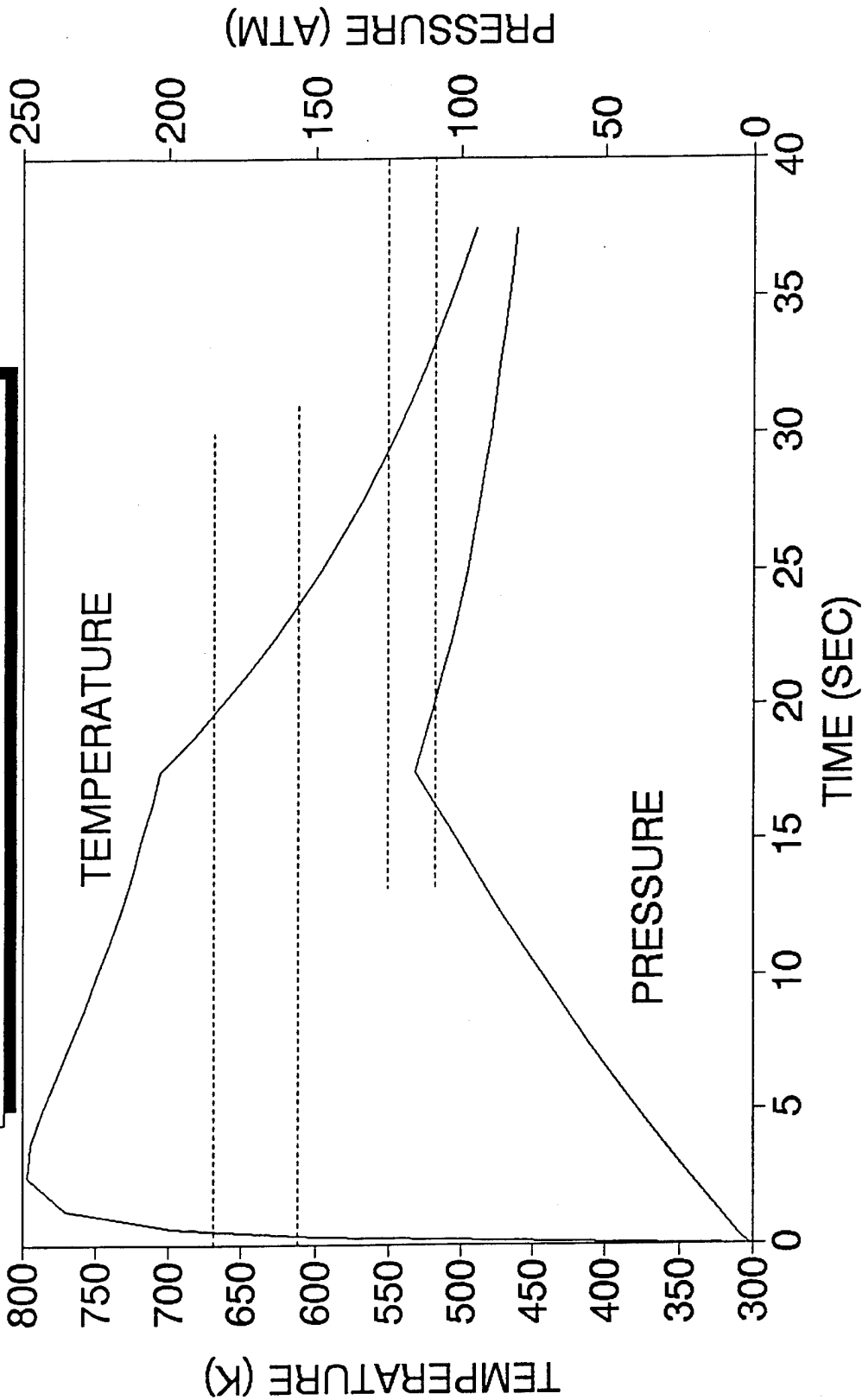

10/19/93

Figure 12. Effect of Terminating Driver Gas Filling

# TVEF DRIVER GAS

0.8 GPM IN - VENT WHEN PRESSURIZED

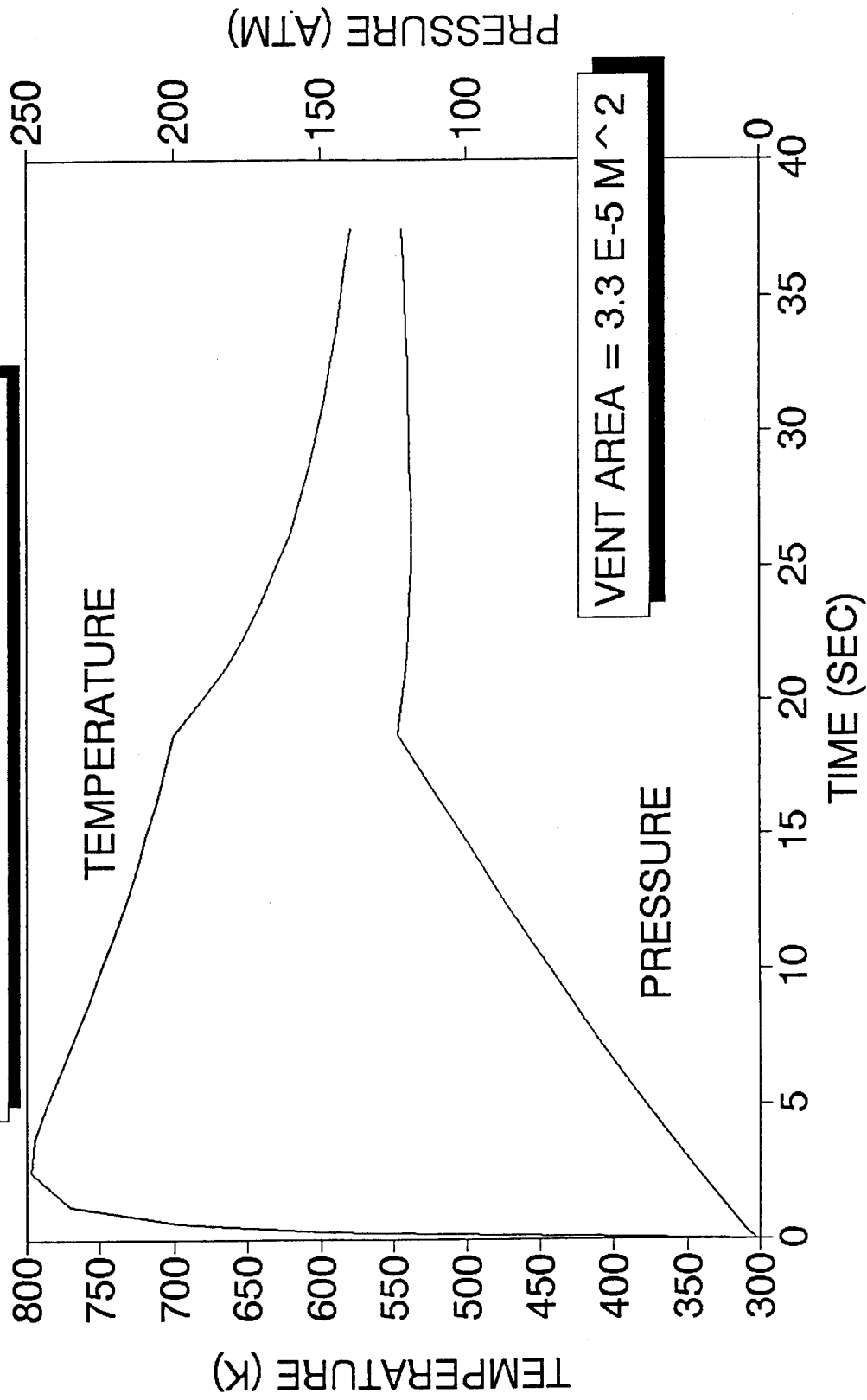

11/4/93

Figure 13. Extending Test Time by Driver Gas Venting

## 5. ESTIMATED SCHEDULE AND COST

Cost estimates were made by defining and scheduling the tasks (Figure 14), identifying the engineering services necessary to complete the design as well as overseeing fabrication and construction and by itemizing purchased parts and services. Purchased part costs were estimated from catalog items, vendor quotes and engineering estimates. Fabrication and site construction costs were developed from responses to RFQs.

Major cost items are:

Engineering Services	\$436,000
Facility Hardware	\$102,000
Gas Supply Hardware	\$ 43,000
Instrumentation and Control	\$ 17,000
Purchased Services	\$ 27,000
Site Construction & Installation	\$246,000
Total	\$871,000

All estimates are in 1993 dollars. No spares or contingencies have been included and no consideration has been given to satisfying Government regulations such as environmental impact statements, site specific approvals and facility procurement procedures.

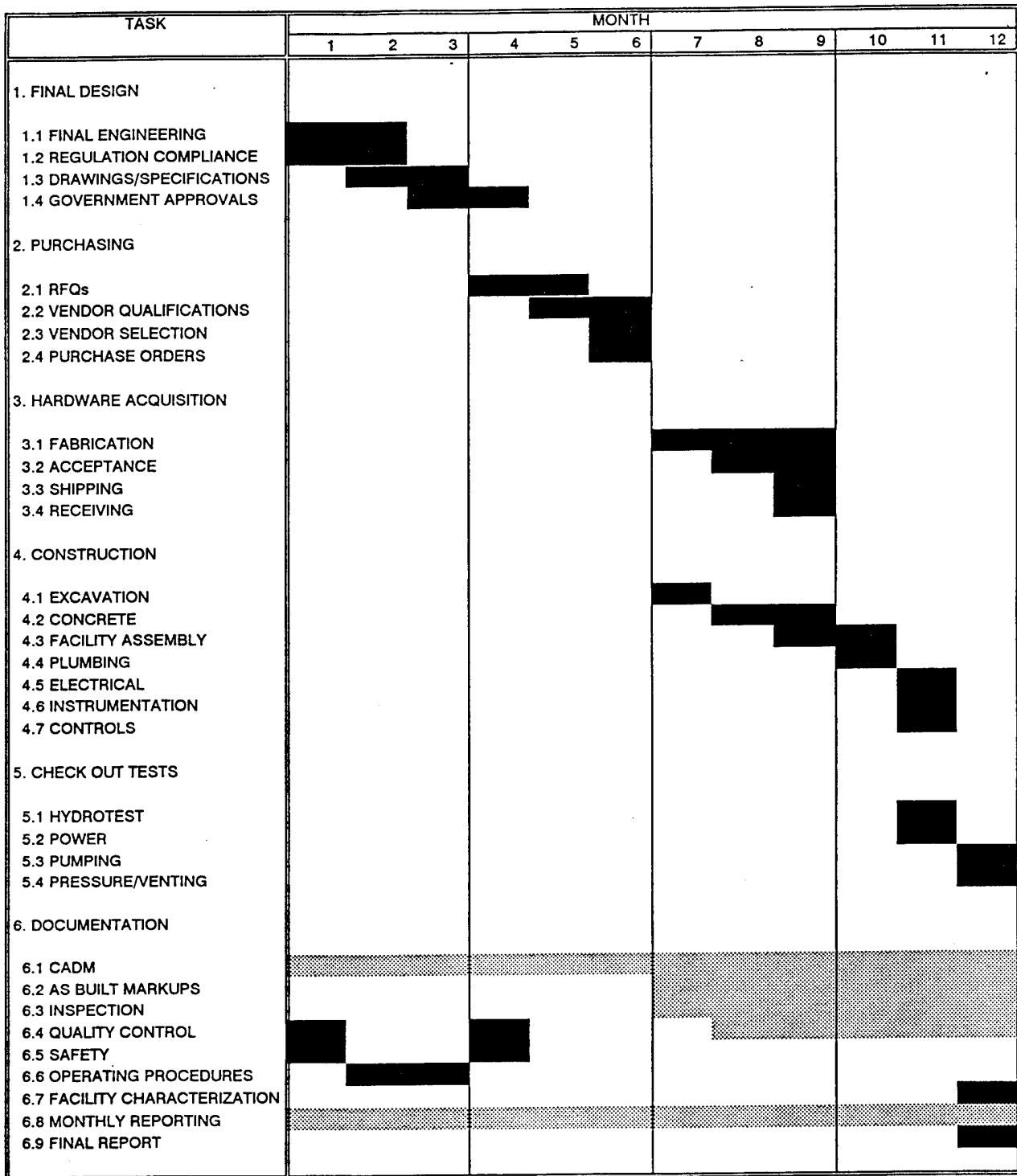

Figure 14. TVEF Completion Schedule

## **6. SUMMARY**

### **6.1 Conclusions**

The following conclusions are drawn as a result of the design study:

- The TVEF is technically feasible and can be designed and constructed with a high degree of confidence. Preliminary engineering design is complete.
- The TVEF can be constructed in closed proximity to the existing facilities without interference and can share the use of the 1/6th Scale Test Bed heated driver gas supply system, electrical system and control bunker.
- Within the uncertainties in the data set taken by ARL in its initial shakedown run, the coded driver filling model reproduces the measured temperature and pressure time histories reasonably well thereby validating the ad hoc heat transfer correlation.
- Sufficient heated gas supply and control authority are available to provide design test conditions for test times adequate to initiate Throat Valve tests. Heat transfer has a significant effect on the driver gas temperature and pressure even at the short times necessary to fill the TVEF driver. Preheating of the driver gas fill line to the design temperature is required.
- Venting a controlled amount of driver gas after the driver is filled while continuing the fill gas supply is an effective means of extending the test time. Appropriate driver gas venting can be achieved with a simple constant area vent valve thereby relieving the need for an expensive feedback control system.

### **6.2 RECOMMENDATIONS**

The following recommendations are made as a result of the design study:

- The TVEF facility final design and construction should proceed as

soon as funds are available.

- The TVEF site should be surveyed by a licensed land surveyor to develop maps with true dimensions, land elevations, and site details including the pebble-bed heater, cryogenic pump, NEMA boxes, electrical junction boxes, diaphragm building and control bunker.
- Soil tests shall be made at the TVEF site to obtain current soil properties to a minimum depth of 10 feet.
- The existing 1/6th Scale Test Bed drainage system should be inspected and serviced so that it can accommodate the TVEF.
- The existing TVEF driver must be refurbished, reassembled and hydrotested to ASME standards to assure safe operation.
- Final engineering can achieve additional simplifications. For example, it appears that the expansion tube stiffeners are only required near the support locations.
- The TVEF driver thrust stand, expansion tube, expansion tube thrust stand, mounting rail assemblies and expansion tube aft support structure should be prefabricated and shipped to the site for installation by a construction contractor.
- The present driver gas filling model should be used to design definitive 1/6th Scale Test Bed driver filling experiments which encompass various processes included in the model. In particular, careful experiments should be defined to test the validity of the heat transfer correlation over a wide range of Raleigh numbers of interest to TVEF filling strategies.
- Alternate driver filling methods should be developed to minimize driver gas stratification if it proves to be detrimental to throat valve performance and shock waveform formation.
- Fast response (time constant less than 0.1 seconds) thermocouples must be used to measure the TVEF driver gas temperature.

INTENTIONALLY LEFT BLANK.

## **7. REFERENCES**

**1. Soils, Geology, Foundations and Pavement Design Data for the NIKE-X Shock Tube Facility, Black and Veatch Consulting Engineers, August 1966.**

**2. Design Analysis Calculations - NIKE-X Shock Tube Facility, Black and Veatch Consulting Engineers, September 1966**

INTENTIONALLY LEFT BLANK.

## **APPENDIX A DESIGN CALCULATIONS**

**A Reaction Pad Soil Loading**

**B Reaction Pad Loads and Stress Resultants (N, V & M)**

**C Reaction Pad Stresses**

**D Reaction Pad Universal Mounting Rails**

**E Reaction Truss Loads, Stress Resultants and Stresses**

**F Expansion Tube Loads, Stress Resultants and Stresses**

**G Heated Fill Tube Stresses**

INTENTIONALLY LEFT BLANK.



PROJECT TVEF

BY AD  
193/11 1 OF

SUBJECT REACTION PAD SOIL LOADING

CKD — A

PASSIVE SOIL PRESSURE RESISTANCE FORCES & SOIL FRICTIONAL RESISTANCE FORCES AVAILABLE TO REACT AGAINST REACTION PAD SURFACES.

ASSUME: COHESIONLESS SOIL (SANDY SILT/SILTY SAND):

$C = 0$  SOIL COHESION (INTERPARTICLE ATTRACTION)  
 $\phi = 30^\circ$  SOIL ANGLE OF INTERNAL FRICTION  
 $\mu = .33 (-)$  COEFFICIENT OF FRICTION  
 $W = 115 \# / F_t^2$  NOMINAL WEIGHT OF SOIL (ABOVE WATER TABLE)  
 $W_b = 65 \# / F_t^2$  BUOYED WEIGHT OF SOIL (BELOW WATER TABLE)  
 $d_w = 4 F_t$  DEPTH TO WATER TABLE LEVEL

THAT THE PASSIVE (AND ACTIVE) SOIL PRESSURES WILL OCCUR IN THE SOIL ACCORDING TO THE RANKINE\* THEORY (AND/OR THE COULOMB\* THEORY, WHICH GIVES IDENTICAL RESULTS IN THIS CASE).

THEN: \* REFERENCE: BOWLES (1988) "FOUNDATION ANALYSIS AND DESIGN" MCGRAW HILL

THE COEFFICIENT OF PASSIVE SOIL PRESSURE IS:

$$K_p = \frac{1 + \sin \phi}{1 - \sin \phi} \equiv \tan^2 \left( 45^\circ + \frac{\phi}{2} \right)$$

$$K_p = \tan^2 \left( 45^\circ + \frac{30^\circ}{2} \right) = \tan^2 60^\circ = \boxed{3 = K_p}$$

THE COEFFICIENT OF ACTIVE SOIL PRESSURE IS:

$$K_A = \frac{1 - \sin \phi}{1 + \sin \phi} \equiv \tan^2 \left( 45^\circ - \frac{\phi}{2} \right)$$

$$K_A = \tan^2 \left( 45^\circ - \frac{30^\circ}{2} \right) = \tan^2 30^\circ = \boxed{1/3 = K_A} \quad (\text{REF})$$



PROJECT IVEF

BY LD  
93/11

2  
OF

SUBJECT REACTION PAD SOIL LOADING

CKD

A

REACTION PAD CROSS-SECTION:

(PAD LENGTH = 93')

FREE FIELD NET  
BUOYED EFFECTIVE  
SOIL PRESSURE  
GRADIENT.

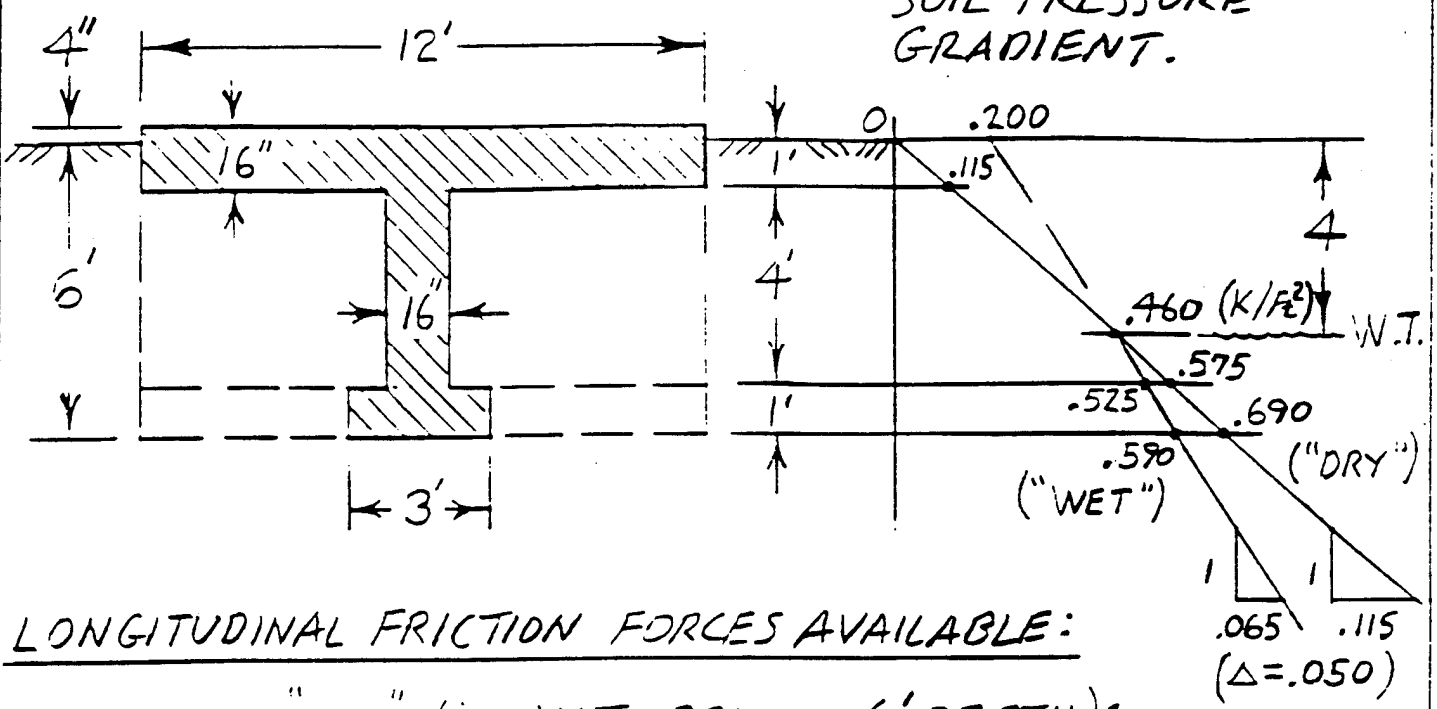

LONGITUDINAL FRICTION FORCES AVAILABLE:

IF SOIL IS "DRY" (ie. W.T. BELOW 6' DEPTH):

FRICTION ON SIDES:

$$F_{m_s} = 2 \left( \frac{.690}{2} \times 6 \right) \times 93 \times .33 = 127.0 \text{ K } (\text{@ } 4' \text{ DEPTH}) \quad \textcircled{1}$$

FRICTION ON FOOTING:

(ON TOP SURFACE OF FOOTING)

$$F_{m_{ft}} = \left( .575 \times \frac{20}{12} \right) \times 93 \times .33 = 29.4 \text{ K } (\text{@ } 5' \text{ DEPTH}) \quad \textcircled{2}$$

(ON BOTTOM SURFACE OF FOOTING)

$$F_{m_{fb}} = (.690 \times 3) \times 93 \times .33 = 63.5 \text{ K } (\text{@ } 6' \text{ DEPTH}) \quad \textcircled{3}$$

FRICTION ON BOTTOM OF SLAB:

$$F_{m_{sb}} = (.115 \times 10.67) \times 93 \times .33 = 37.6 \text{ K } (\text{@ } 1' \text{ DEPTH}) \quad \textcircled{4}$$



PROJECT TVEF

BY LD  
1/93/11 3 OF

SUBJECT REACTION PAD SOIL LOADING

CKD — A

$z$  (5) DISTRIBUTED  $z$  (7)  
TOTAL LONGITUDINAL FRICTION FORCE AVAILABLE:

$$\begin{array}{rcl}
 37.6 \text{ K} & \times 1 F_t & = 37.6 F_t \cdot \text{K} \\
 127.0 & \times 4 & = 508.2 \\
 29.4 & \times 5 & = 147.1 \\
 63.5 & \times 6 & = 381.2
 \end{array}$$

$$257.6 \text{ K} @ 4.169' = 1074.1 F_t \cdot \text{K}$$

DISTRIBUTED LONGITUDINAL FRICTION FORCE AVAILABLE:

$$f = \frac{F}{L} = \frac{257.6}{93} = 2.770 \text{ K} / F_t @ 4.169 F_t \text{ DEPTH}$$

ADDITIONAL LONGITUDINAL DISCRETE FRICTION FORCES ON THE FOOTINGS OF THE KEYS:

(ON BOTTOM SURFACE OF FOOTING OF EACH KEY)

$$\bar{F}_{K, F_0} = (.690 \times 3) \times (12-3) \times .33 = 6.15 \text{ K} (@ 6' \text{ DEPTH})$$

ADDITIONAL FORCE ON ALL SIX KEYS (TOTAL):

$$36.9 \text{ K} @ 6' = 221.3 F_t \cdot \text{K}$$

TOTAL LONGITUDINAL FRICTION FORCE AVAILABLE:

$$294.5 \text{ K} @ 4.398 F_t = 1295.4 F_t \cdot \text{K}$$

PROJECT TVEFBY CKD  
93/11 4  
OFSUBJECT REACTION PAD SOIL LOADINGCKD      AIF WATER TABLE IS @ 4 FOOT DEPTH:REDUCTION IN FRICTION FORCES ON SIDES:

$$\Delta F_{M_S} = -2 \left( \frac{.1}{2} \times 2 \right) \times 93 \times .33 = -6.1 \text{ K} \quad (\text{@ } 5.333' \text{ DEPTH})$$

(11)

REDUCTION IN FRICTION FORCES ON FOOTING:

(ON TOP SURFACE OF FOOTING)

$$\Delta F_{M_{Ft}} = - \left( .050 \times \frac{20}{12} \right) \times 93 \times .33 = -2.6 \text{ K} \quad (\text{@ } 5' \text{ DEPTH})$$

(12)

(ON BOTTOM SURFACE OF FOOTING)

$$\Delta F_{M_{Fb}} = - \left( .100 \times 3 \right) \times 93 \times .33 = -9.2 \text{ K} \quad (\text{@ } 6' \text{ DEPTH})$$

(13)

TOTAL REDUCTION IN FRICTION FORCE AVAILABLE:

$$-6.1 \text{ K} \times 5.333' = -32.7 \text{ Ft} \cdot \text{K}$$

$$-2.6 \quad \times 5 \quad = -12.8$$

$$-9.2 \quad \times 6 \quad = -55.2$$

$$-17.9 \text{ K @ } 5.629' = -100.8 \text{ Ft} \cdot \text{K}$$

(15)

(16)

(17)

NOTE THAT THE  
PRESENCE OF WATER  
REDUCES THE  
AVAILABLE FRICTION  
FORCE BY 6.9%

TOTAL DISTRIBUTED LONGITUDINAL FRICTION FORCE AVAILABLE:

$$257.5 \text{ K} \times 4.169' = 1074.1 \text{ Ft} \cdot \text{K} \quad (\text{AVAILABLE IF DRY})$$

$$-17.9 \quad \times 5.629 = -100.8 \quad (\text{-BUOYANT LOSS})$$

$$239.7 \text{ K @ } 4.060' = 973.3 \text{ Ft} \cdot \text{K} \quad (\text{NET AVAILABLE IF WET})$$

(25)

(26)

(27)

DISTRIBUTED LONGITUDINAL FRICTION FORCE AVAILABLE:

$$f = \frac{F}{L} = \frac{239.7}{93} = 2.577 \text{ K/Ft} \quad \text{@ } 4.06 \text{ Ft DEPTH}$$

(29)

(VERIFY THESE "WET" VALUES BY DIRECT CALCULATION)



PROJECT	1 VEF	BY	<del>165</del> 93/11	5 OF
SUBJECT	REACTION PAD SOIL LOADING	CKD	—	A

$$F_{MSB} = (.115 \times 10.667) \times 93 \times .33 = 37.6 \text{ K} \times 1' = 37.6 \text{ Ft-K}$$

$$\left\{ 2 \left( \frac{.460}{2} \times 4 \right) \times 93 \times .33 = 56.5 \times 2.667 = 150.6 \right.$$

$$F_{MS} = \left\{ 2 (.460 \times 2) \times 93 \times .33 = 56.5 \times 5 = 282.3 \right.$$

$$\left. 2 (.065 \times 2) \times 93 \times .33 = 8.0 \times 5.333 = 42.6 \right.$$

$$F_{M_{\pm}} = .525 \times \left( \frac{20}{12} \right) \times 93 \times .33 = 26.9 \times 5 = 134.3$$

$$F_{M_{fb}} = .590 \times 3 \times 93 \times .33 = 54.3 \times 6 = 325.9$$

DIRECT CALCULATION CHECK  $239.7 \text{ K} @ 4.060' = 973.3 \text{ Ft-K}$  ←

(25)

(26)

(27)





PROJECT	DATE	BY	1/
		93/11	OF
SUBJECT	REACTION PAD SOIL LOADING	CKD	A

TOTAL LONGITUDINAL FORCES AVAILABLE:

FRICTION FORCE (p3) :  $294.5 \text{ K} @ 4.398' = 1295.4 \text{ Ft}\cdot\text{K}$

PASSIVE SOIL FORCE (p6) :  $380.7 \text{ K} @ 4.018' = 1529.5 \text{ Ft}\cdot\text{K}$

TOTAL FORCE AVAILABLE:  $675.2 \text{ K} @ 4.184' = 2825.0 \text{ Ft}\cdot\text{K}$

(41)

(42)

(43)

APPLIED LOAD:

$400 \text{ K} @ 5' ** = 2000 \text{ Ft}\cdot\text{K}$

NOTE THAT:

**\*\* ABOVE GRADE**

- SOIL FRICTION FURNISHES SLIGHTLY LESS THAN HALF OF THE AVAILABLE REACTIVE FORCE,  $\approx 44\% \left( \frac{294.5}{675.2} \right)$ .
- SOIL PASSIVE PRESSURE RESISTANCE FURNISHES SLIGHTLY MORE THAN HALF OF THE AVAILABLE REACTIVE FORCE,  $\approx 56\% \left( \frac{380.7}{675.2} = .5638\% \right)$ .
- ABOUT 60%  $\left( \frac{400}{675.2} = .5924\% \right)$  OF THE AVAILABLE REACTIVE FORCE IS USED TO REACT THE 400 K REACTION LOAD.

IN ORDER TO INVESTIGATE THE REACTION PAD, ITS AVAILABLE SOIL LOADING WILL BE PRORATED DOWN TO REACTIVE SOIL LOADING THAT EQUILIBRATES THE APPLIED 400 K LOADING. THAT IS, 56.38% OF THE AVAILABLE REACTIVE SOIL FORCES WILL BE APPLIED TO THE REACTION PAD.

**\* VERY CONSERVATIVE ESTIMATE**



PROJECT	1 VEF	BY	1/2B 1/93/11	8 OF
SUBJECT	REACTION PAD SOIL LOADING	CKD		A

SUMMARY OF EQUILIBRATING SOIL REACTIVE LOADING:

FORCE IN TERMS OF SOIL DEPTH W.R.T. SLAB-STEM INTERFACE

DISTRIBUTED LONGITUDINAL FRICTION FORCE:  $5.2006 \frac{Ft \cdot K}{Ft}$  (45)

152.62 K @ 4.169' 636.28 Ft·K @ 3.169' 483.66 Ft·K

DISCRETE FRICTION FORCE ON BOTTOM OF EACH KEY: (51) (52) (53)

3.64 K @ 6 Ft 21.85 Ft·K @ 5 Ft 18.21 Ft·K

TOTAL DISCRETE FRICTION FORCE ON BOTTOM OF ALL KEYS: (54) (55) (56)

21.85 K @ 6 Ft 131.11 Ft·K @ 5 Ft 109.26 Ft·K

TOTAL REACTIVE SOIL FRICTION FORCE: (57) (58) (59)

174.47 K @ 4.398 Ft 767.39 Ft·K @ 3.398 Ft 592.91 Ft·K

PASSIVE SOIL PRESSURE FORCE AGAINST END SURFACE: (61) (62) (63)

7.87 K @ 3.899 Ft 30.68 Ft·K @ 2.899 Ft 22.81 Ft·K

PASSIVE SOIL PRESSURE FORCE AGAINST EACH KEY: (64) (65) (66)

36.28 K @ 4.022 Ft 145.90 Ft·K @ 3.022 Ft 109.62 Ft·K

TOTAL PASSIVE PRESSURE FORCE AGAINST ALL KEYS: (67) (68) (69)

217.66 K @ 4.022 Ft 875.40 Ft·K @ 3.022 Ft 657.74 Ft·K

TOTAL REACTIVE SOIL PASSIVE PRESSURE FORCE: (71) (72) (73)

225.53 K @ 4.018 Ft 906.07 Ft·K @ 3.018 Ft 680.55 Ft·K

TOTAL LONGITUDINAL SOIL REACTIVE FORCE: (74) (75) (76)

400 K @ 4.184 Ft 1673.46 Ft·K @ 3.184 Ft 1273.46 Ft·K

(77) (78) (79)



PROJECT	1 V - 1	BY	CKD	9
			1/93/11	OF
SUBJECT	REACTION PAD SOIL LOADING	CKD		A

VERTICAL REACTIVE SOIL LOADING TO RESIST OVERTURNING MOMENT ON REACTION PAD.

ASSUME THAT THE **400 K** LOADING OCCURS **56 INCHES** ABOVE THE TOP OF THE PAD.  
(I.E. 6 FT ABOVE THE SLAB-STEM INTERFACE).

THE 400 K INDUCED OVERTURNING MOMENT IS:

$$M = 400 \times 6 + 1273.46 \stackrel{(79)}{=} 400 \times (6 + 3.184) = 3673.46$$
$$M = 3673.46 \text{ Ft}\cdot\text{K} \quad * (9.184')$$

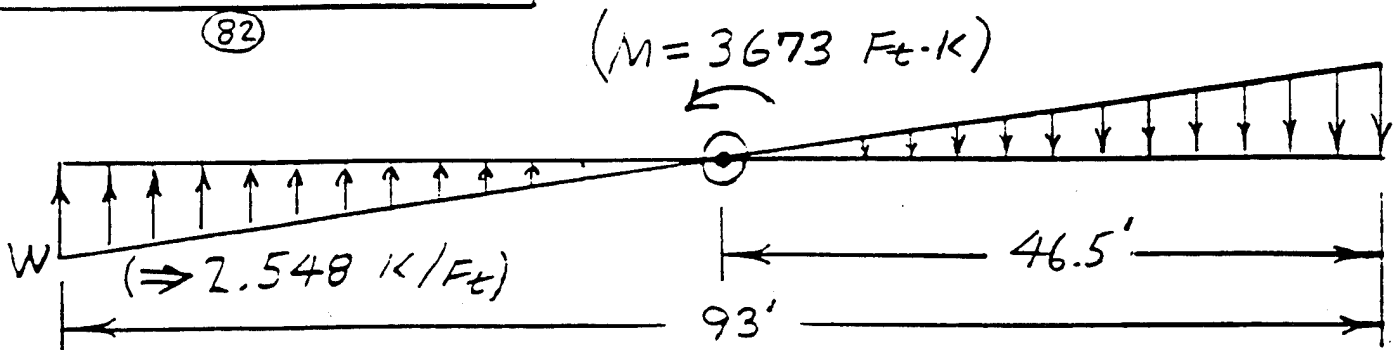

$$\left(\frac{W \times 46.5}{2}\right) \left(\frac{2}{3} \times 46.5\right) = \frac{M}{2}$$

$$W = \frac{3}{2} \frac{M}{46.5^2} = \frac{1.5 \times 3673.5}{46.5^2} = 2.548,36 \text{ K/Ft}$$

$$W = 2.548 \text{ K/Ft}$$

(83)

(NOTE THAT THIS OVERTURNING MOMENT INDUCES VERY LOW SOIL PRESSURES)

\* NOTE THAT 9.184 FT IS THE EFFECTIVE ECCENTRICITY IN THE MORE SEVERE "DRY SOIL" CASE.

THE EFFECTIVE ECCENTRICITY AND CORRESPONDING VERTICAL SOIL LOADING ARE REDUCED IN THE LESS ECCENTRICALLY SEVERE SUBMERGED SOIL CASE.





PROJECT 1 V L F

BY UCD  
93/11

2  
OF

SUBJECT REACTION PAD LOADS  
AND STRESS RESULTANTS (N, V, & M)

CKD

B

57.151 59.249

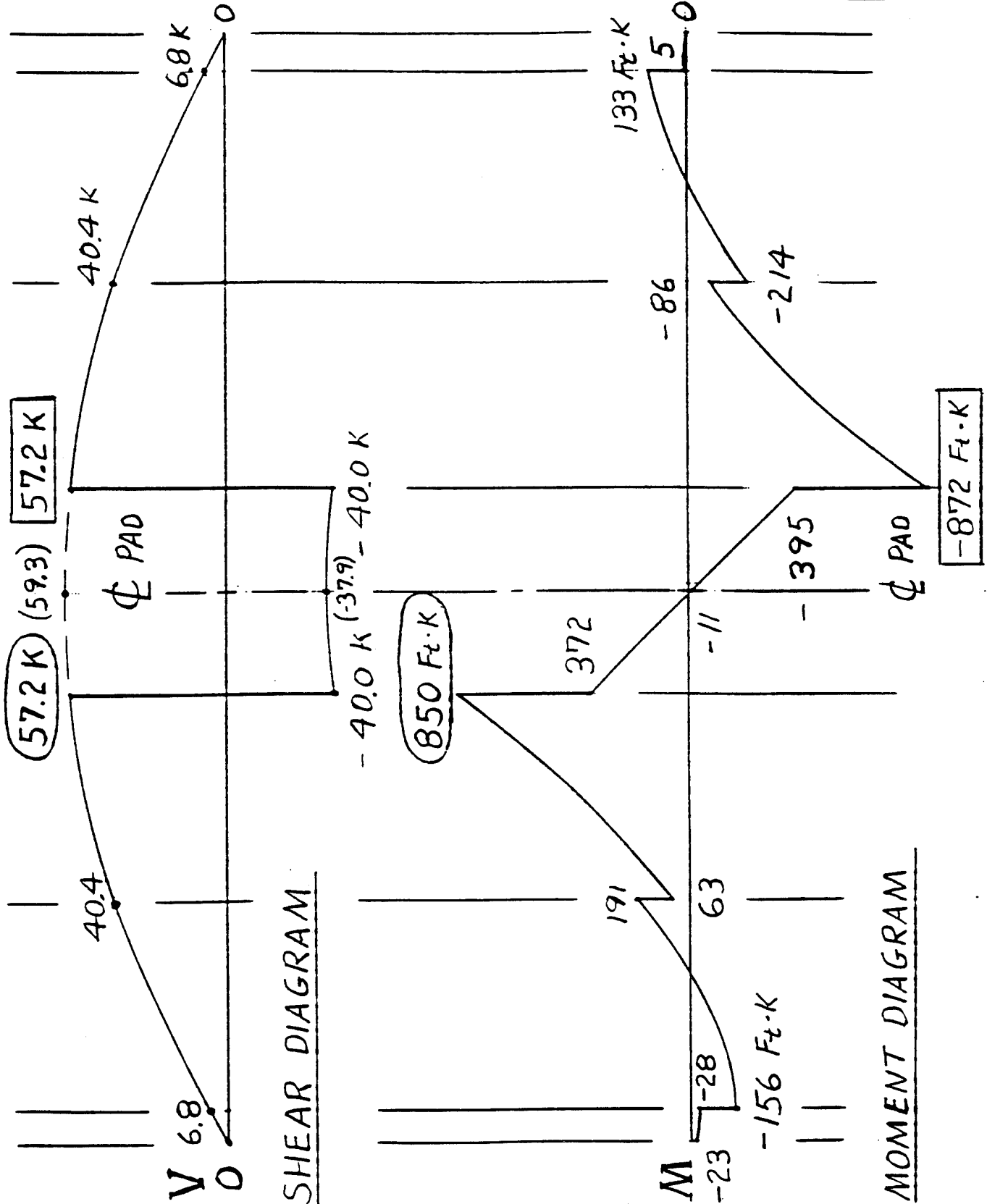



PROJECT <u>1 VEF</u>	BY <u>[Signature]</u>	3 OF 3
SUBJECT <u>REACTION PAD LOADS AND STRESS RESULTANTS (N, V, &amp; M)</u>	CKD <u>    </u>	B

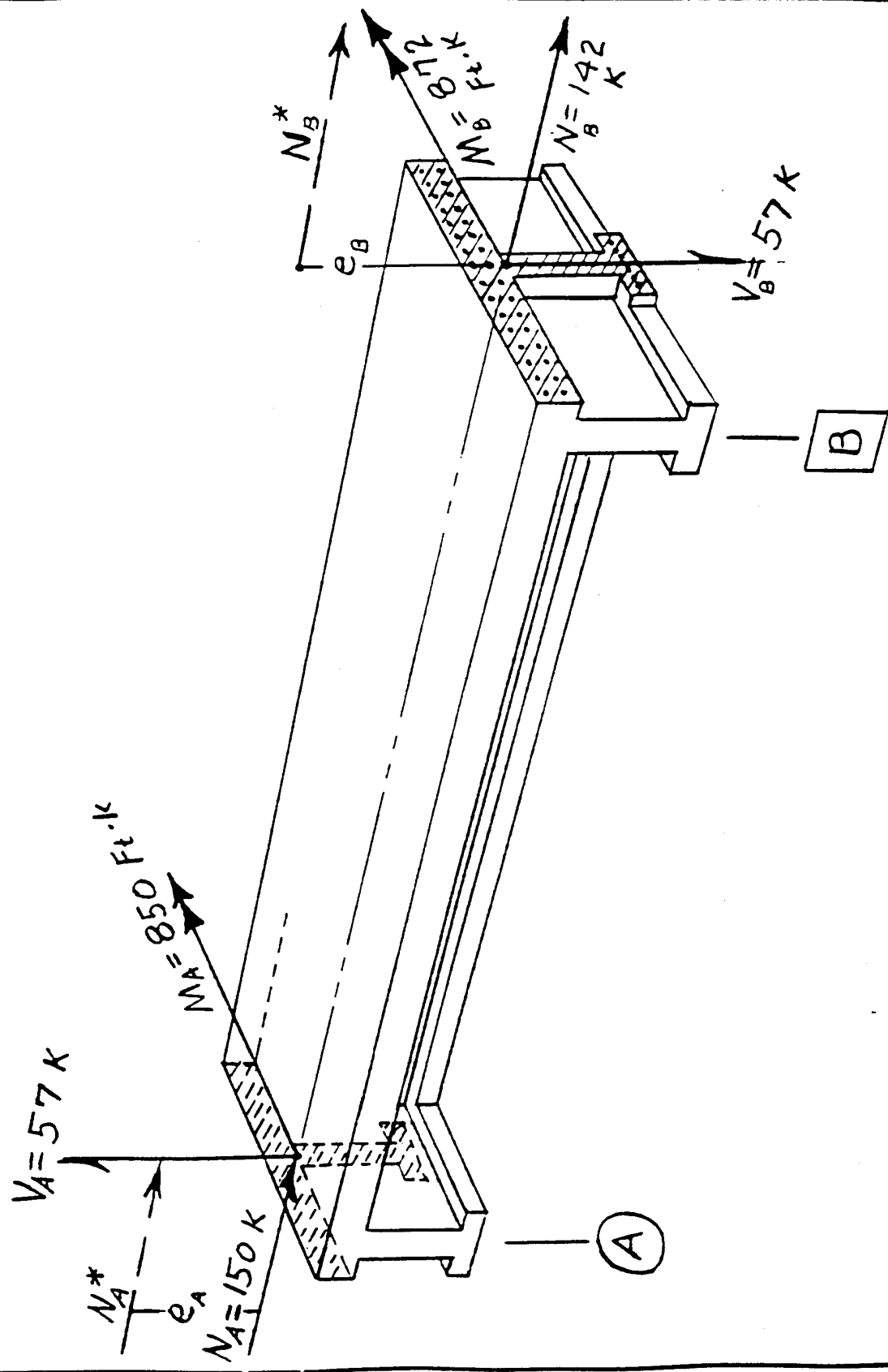

REACTION PAD STRESS RESULTANTS (A) & (B)



PROJECT I VET

BY [Signature]  
/93/11 4 OF

SUBJECT REACTION PAD LOADS AND STRESS RESULTANTS (N, V, & M)

CKD — B

STRESS RESULTANTS IN KEY FOOTING:

ASSUME THAT THE RELATIVE STIFFNESSES ARE SUCH THAT THE "SHEAR INFLECTION LINE" (ZERO SHEAR) OCCURS IN THE KEY WALL 6" ABOVE THE TOP OF THE FOOTING.

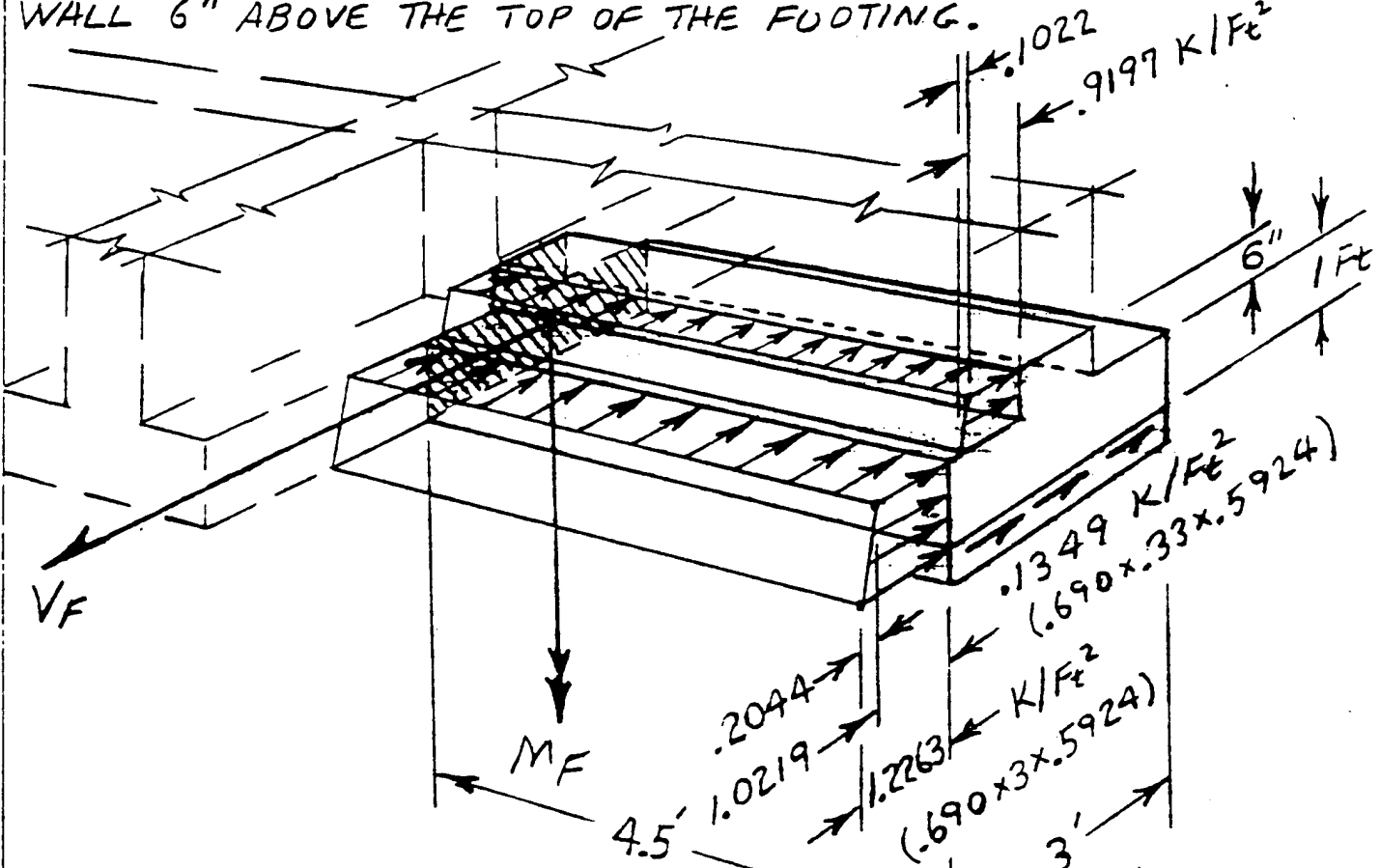

LOAD

$\frac{V_F}{\Sigma (123)}$

$\frac{M_F}{\Sigma (124)}$

$\frac{1}{2} (.9197 + 1.0219) \times .5 \times 4.5 = 2.184 \text{ K} \times \frac{1}{2} (4.5) = 4.915 \text{ Ft} \cdot \text{K}$

$\frac{1}{2} (1.0219 + 1.2263) \times 1 \times 4.5 = 5.058 \times 2.25 = 11.382$

$(.1349) \times 3 \times 4.5 = 1.821 \times 2.25 = 4.097$

$9.064 \text{ K} @ 2.25' = 20.394 \text{ Ft} \cdot \text{K}$   
(27")

$V_F = 9.1 \text{ K}$   
 $M_F = 20.4 \text{ Ft} \cdot \text{K}$

(NOTE THAT  $V_F$  &  $M_F$  MAY VARY ACCORDING TO WHERE THE ACTUAL ZERO SHEAR LINE (CURVED) OCCURS IN THE KEY WALL.)



PROJECT 7 VEF

BY KP  
193/11

5  
OF

SUBJECT REACTION PAD LOADS  
AND STRESS RESULTANTS (N, V, & M)

CKD —

B

STRESS RESULTANTS IN (UNIT WIDTH OF) KEY WALL  
AND IN TOP SLAB AS INDUCED BY KEY WALL:

UNIT (ONE FOOT) WIDTH OF SLAB JUST ABOVE KEY WALL:

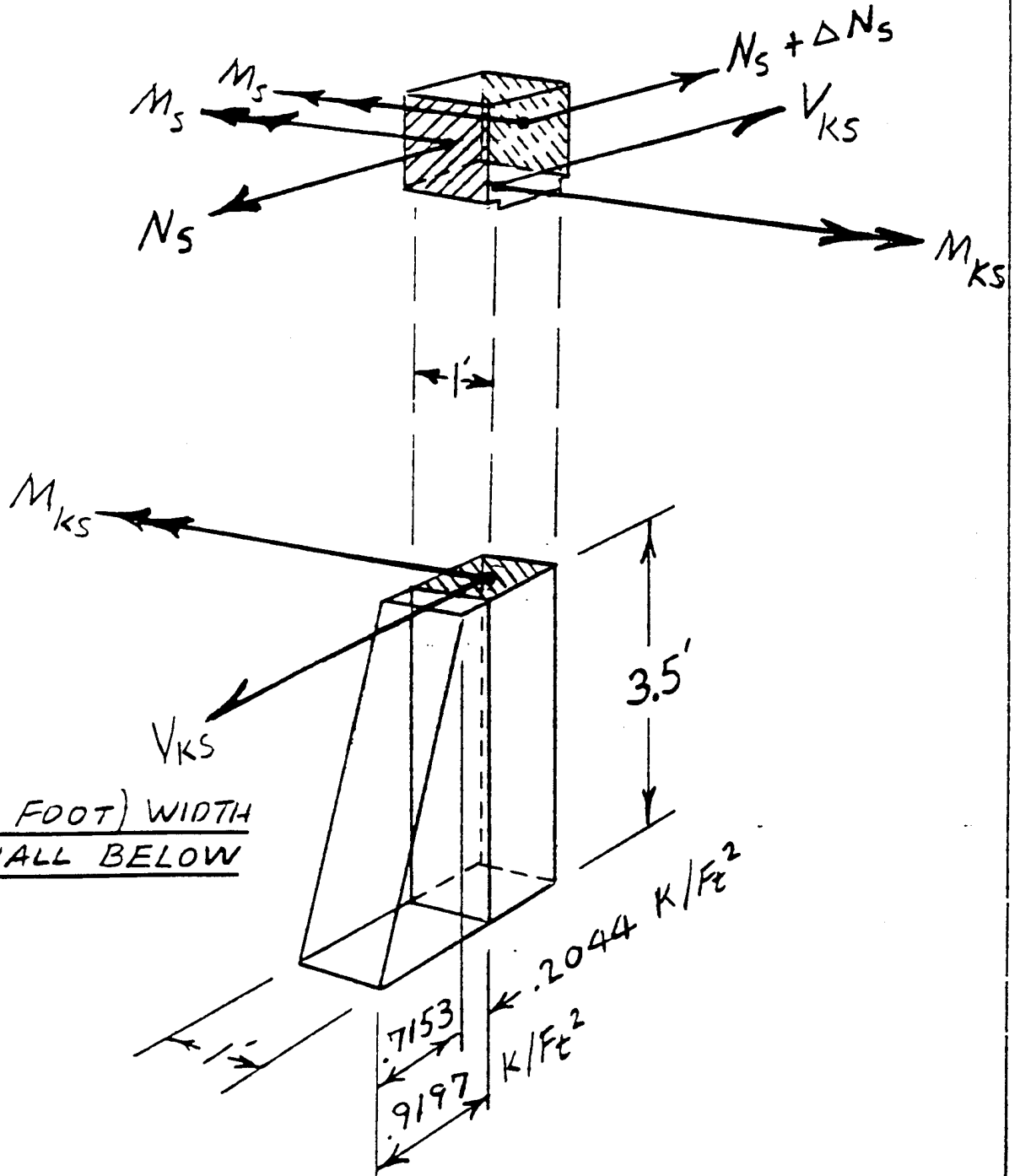

UNIT (ONE FOOT) WIDTH  
OF KEY WALL BELOW  
SLAB:

PROJECT I V E TBY 10/27  
093/116  
OFSUBJECT REACTION PAD LOADS  
AND STRESS RESULTANTS (N, V, & M)CKD     

B

IN THE KEY WALL:

<u>LOAD</u>	$\frac{V_{KS}}{\Sigma (123)}$	$\frac{M_{KS}}{\Sigma (124)}$
$\frac{1}{2} (.7153) \times 1 \times 3.5 = 1.252 \text{ K} \times \frac{2}{3} \times 3.5 = 2.921 \text{ Ft}\cdot\text{K}$		
$.2044 \times 1 \times 3.5 = \underline{.715}$		$\times \frac{1}{2} \times 3.5 = \underline{1.252}$
	$1.967 \text{ K} @ 2.121' = 4.173 \text{ Ft}\cdot\text{K}$	
	(25.5")	

$$V_{KS} = 2.0 \text{ K}$$

$$M_{KS} = 4.2 \text{ Ft}\cdot\text{K}$$

IN THE SLAB ABOVE THE KEY WALL:

$$2 M_S = M_{KS} + \left(\frac{8}{12}\right) V_{KS}$$

$$M_S = \frac{1}{2} \left( 4.17 + \frac{2}{3} 1.97 \right) = 2.74 \text{ Ft}\cdot\text{K}$$

$$M_S = 2.8 \text{ Ft}\cdot\text{K}$$

PROJECT LVFFBY AD  
1/93/111  
OFSUBJECT REACTION PAD STRESSES

CKD

C

REBAR STEEL: ASSUME THAT IT WILL BE BILLET STEEL (ie A 615) WHICH IS THE MOST READILY AVAILABLE.

GRADE	40	60	(EITHER OR BOTH GRADES MAY BE USED AS APPLICABLE.)
$F_u =$	70	90	TENSILE STRENGTH (KSI)
$F_y =$	40	60	YIELD STRENGTH (KSI)

\* ALTERNATES INCLUDE THE RAIL AND AXLE STEELS:

A-617 WHICH HAS IDENTICAL TENSILE STRENGTHS, YIELD STRENGTHS, AND ELONGATIONS IN GRADE 40 AND IDENTICAL TENSILE STRENGTHS AND YIELD STRENGTHS IN GRADE 60 (AND ONLY SLIGHTLY REDUCED ELONGATIONS IN THE SMALLER BAR SIZES).

A-616 WHICH HAS IDENTICAL TENSILE STRENGTHS AND YIELD STRENGTHS (BUT SIGNIFICANTLY REDUCED ELONGATIONS) IN GRADE 60.

NOTE THAT IT HAS NO GRADE 40, BUT IT HAS AN INTERMEDIATE GRADE 50 (80 & 50 KSI).

FOR ALL STEEL (INCLUDING RE-BAR AND STRUCTURAL ROLLED SHAPES, PLATE, BAR, TUBE, ETC.) ASSUME:

$E = 29 \times 10^3$  (KSI) MODULUS OF ELASTICITY

$\nu = .3$  (-) POISSON'S RATIO

$\gamma = 490$  ( $\#/Ft^3$ ) WEIGHT DENSITY

$\alpha = 6.5 \times 10^{-6}$  ( $1/^\circ F$ ) COEFFICIENT OF THERMAL EXPANSION

\* NOTE THAT THESE ALTERNATE RAIL AND AXLE STEELS ARE NOT GENERALLY READILY AVAILABLE.



PROJECT

BY LDD

2

93/11

OF

SUBJECT

REACTION PAD STRESSES

CKD

C

CONCRETE:

ASSUME THAT IT WILL BE 3000 PSI CONCRETE:

 $f'_c = 3000$  (psi) ULTIMATE 28 DAY COMPRESSIVE STRENGTH $E_c = 3200$  (ksi) MODULUS OF ELASTICITY ( $E_c = 33 W_c^{1.5} \sqrt{f'_c}$ ) $\nu_c = .2$  (-) POISSON'S RATIO (= 3,156,000 psi) $W_c = 145$  (#/ft<sup>3</sup>) WEIGHT DENSITY $\alpha_c = 5.5 \times 10^{-6}$  (/°F) COEFFICIENT OF THERMAL EXPANSION $n = 9$  (-) RATIO OF MODULI OF ELASTICITY ( $\frac{29}{3.2} = 9.06$ )



PROJECT	1-1-1	BY	V/DJ (193/11)	3 OF
SUBJECT	REACTION PAD STRESSES	CKD		C

@ SECTION A: (SEE p. B-1, 2, & 3)

NOTE THAT THIS IS THE CRITICAL SECTION FOR MAXIMUM POSITIVE MOMENT THAT INDUCES THE MAXIMUM TENSILE LOAD IN THE RE-BARS THAT ARE IN THE STEM (I.E., THE LONGITUDINAL RE-BARS IN THE FOOTING).

THEREFORE, THIS SECTION GOVERNS THE MAXIMUM AMOUNT OF STEM RE-BAR STEEL IN THE REACTION PAD. THE LOCATIONS OF THE "CUT-OFF" POINTS WHERE THE STEM RE-BAR AREA MAY BE REDUCED MAY BE OBTAINED DIRECTLY FROM THE MOMENT DIAGRAM.

THE MAXIMUM SHEAR ALSO OCCURS AT THIS SECTION (AS WELL AS AT SECTION B). THIS MAXIMUM SHEAR GENERATES THE MAXIMUM SHEAR STRESS IN THE STEM. THEREFORE, THESE SECTIONS GOVERN THE THICKNESS OF THE STEM IN THE REACTION PAD.

ALSO NOTE THAT THE MAXIMUM AXIAL NORMAL COMPRESSIVE STRESS RESULTANT (N) ALSO OCCURS AT THIS SECTION. THIS MAXIMUM N (IN CONJUNCTION WITH THE MAXIMUM POSITIVE MOMENT) GENERATES THE MAXIMUM COMPRESSIVE STRESS IN THE CONCRETE IN THE FLANGE (SLAB). HOWEVER, THIS IS OF ACADEMIC INTEREST ONLY BECAUSE THE REACTION PAD WILL INHERENTLY BE HIGHLY UNDER REINFORCED DUE TO THE MASSIVENESS OF THE CONCRETE, HENCE, THE CONCRETE STRESSES WILL INHERENTLY BE VERY LOW.



		BY <u>U/93/11</u>	4 OF
SUBJECT	REACTION PAD STRESSES	CKD	C

BECAUSE THE CONCRETE STRESSES ARE VERY LOW, A "CRACKED-SECTION" LINEAR ELASTIC ANALYSIS GIVES A REASONABLY GOOD REPRESENTATION OF THE STRUCTURAL ACTION. CONSEQUENTLY, THIS SECTION WILL BE ANALYSED USING THE ALTERNATE DESIGN METHOD (i.e. WORKING STRESS DESIGN) RATHER THAN THE STRENGTH DESIGN METHOD (i.e., ULTIMATE STRENGTH DESIGN). (REF. ACI 318 CODE).

FURTHER, THE COMPRESSION STEEL WILL BE CONSIDERED TO BE EFFECTIVE DIRECTLY WITH THE MODULAR RATIO (THAT IS STRAIN COMPATIBILITY WITHOUT LONG TERM CREEP SLIPPAGE). THIS IS BECAUSE IN THE REACTION PAD THE VERY SHORT TERM LIVE LOAD STRESSES GREATLY DOMINATE OVER THE LONG TERM DEAD LOAD STRESSES. THIS CONTRASTS TO USUAL CONCRETE STRUCTURES IN WHICH THE STEADY STATE LONG TERM GRAVITY INDUCED DEAD LOAD STRESSES DOMINATE OVER THE TRANSIENT LIVE LOAD STRESSES. TO ACCOUNT FOR LONG TERM CREEP IN THE CONCRETE TRANSFERRING LOAD TO THE STEEL FROM THE CONCRETE (i.e. ESSENTIALLY RELAXATION OF DISPLACEMENT COMPATIBILITY BETWEEN THE CONCRETE AND THE STEEL) ACI RECOMMENDS (AND USES IN ALL THEIR EQUATIONS - BOTH ADM AND SDM) DOUBLING THE STRESS LEVEL IN THE COMPRESSION STEEL FROM THAT WHICH WOULD OCCUR BASED ON COMPATIBILITY.

CONSEQUENTLY, THE TRANSFORMED SECTION AREA OF COMPRESSION STEEL WILL BE BASED ON  $n$  (AS IT IS FOR TENSILE STEEL) INSTEAD OF  $2n$  [OR  $(2n-1)$ ] AS IT IS IN THE ACI CODE. HENCE, THE CODE GENERATED EQUATIONS UTILIZING COMPRESSION STEEL CANNOT BE USED DIRECTLY WITHOUT MODIFICATION.



PROJECT	IVER	BY	JOS 93/11	5 OF
SUBJECT	REACTION PAD STRESSES	CKD		C

THE 850  $F_t \cdot K$  MOMENT @ SECTION A IS EQUIVALENT TO A COUPLE CONSISTING OF A PAIR OF EQUAL AND OPPOSITE FORCES  $5.667 F_t \Rightarrow 68$  INCHES APART  $\left(\frac{850}{15.4}\right)$ .

ASSUME INITIALLY THAT THE COMPRESSIVE FORCE IN THE CONCRETE (C) ACTS AT A DISTANCE 4 INCHES BELOW THE TOP SURFACE OF THE CONCRETE REACTION PAD. HENCE, THE COMPRESSIVE FORCE IN THE TOP LAYER OF STEEL IN THE FLANGE (SLAB) (C') IS COINCIDENT WITH THE FORCE IN THE CONCRETE (C). FURTHER, THE BOTTOM LAYER OF STEEL IN THE FLANGE (SLAB) IS COINCIDENT WITH THE NEUTRAL AXIS (WHICH IS AT A DEPTH (kd) OF 12 INCHES) SO THAT THERE ARE NO TENSILE OR COMPRESSIVE FORCES IN IT.

NOTE THAT THIS ASSUMED LOCATION OF (C) BOTH SIMPLIFIES THE INITIAL ANALYSIS CALCULATION AND IS A VERY RATIONALLY ASSUMED LOCATION. THAT IS, FOR A BEAM SUBJECTED TO PURE FLEXURE (WITH NO ADDITIONAL TENSILE OR COMPRESSIVE AXIAL LOADS) AND WITH NORMAL MODERATE UNDERREINFORCEMENT THIS DISTANCE  $\left[\frac{1}{3}(kd)\right]$  WOULD BE ABOUT 4" TO 10" (i.e. NOMINALLY ABOUT  $\left[\frac{1}{8}70 = 8.75\right]$ ) (WHERE NOMINALLY:  $k = \frac{3}{8}$ ,  $\left(\frac{1}{3}k\right) = \frac{1}{8}$ , AND  $j = \left(1 - \frac{1}{3}k\right) = \frac{7}{8}$ ).

- A DECREASE IN REINFORCEMENT AND/OR THE ADDITION OF AN AXIAL TENSILE LOAD TENDS TO REDUCE THESE DISTANCE [OF (C) & (NA)] BELOW TOP SURFACE.
- AN INCREASE IN REINFORCEMENT AND/OR THE ADDITION OF AN AXIAL COMPRESSIVE LOAD TENDS TO INCREASE THESE DISTANCES BELOW THE TOP SURFACE.

HERE IN THE REACTION PAD, THE UNDERREINFORCEMENT DOMINATES OVER THE COMPRESSIVE FORCE (N) AND THE 4" ASSUMPTION IS GOOD.



PROJECT IVER

BY 105  
93/11 6  
OF

SUBJECT REACTION PAD STRESSES

CKD — C

HENCE, AT SECTION A:

(BASED ON THE ASSUMPTION THAT THE NEUTRAL AXIS IS LOCATED 12" BELOW THE TOP SURFACE. ( $\xi_c @ 4$ "))

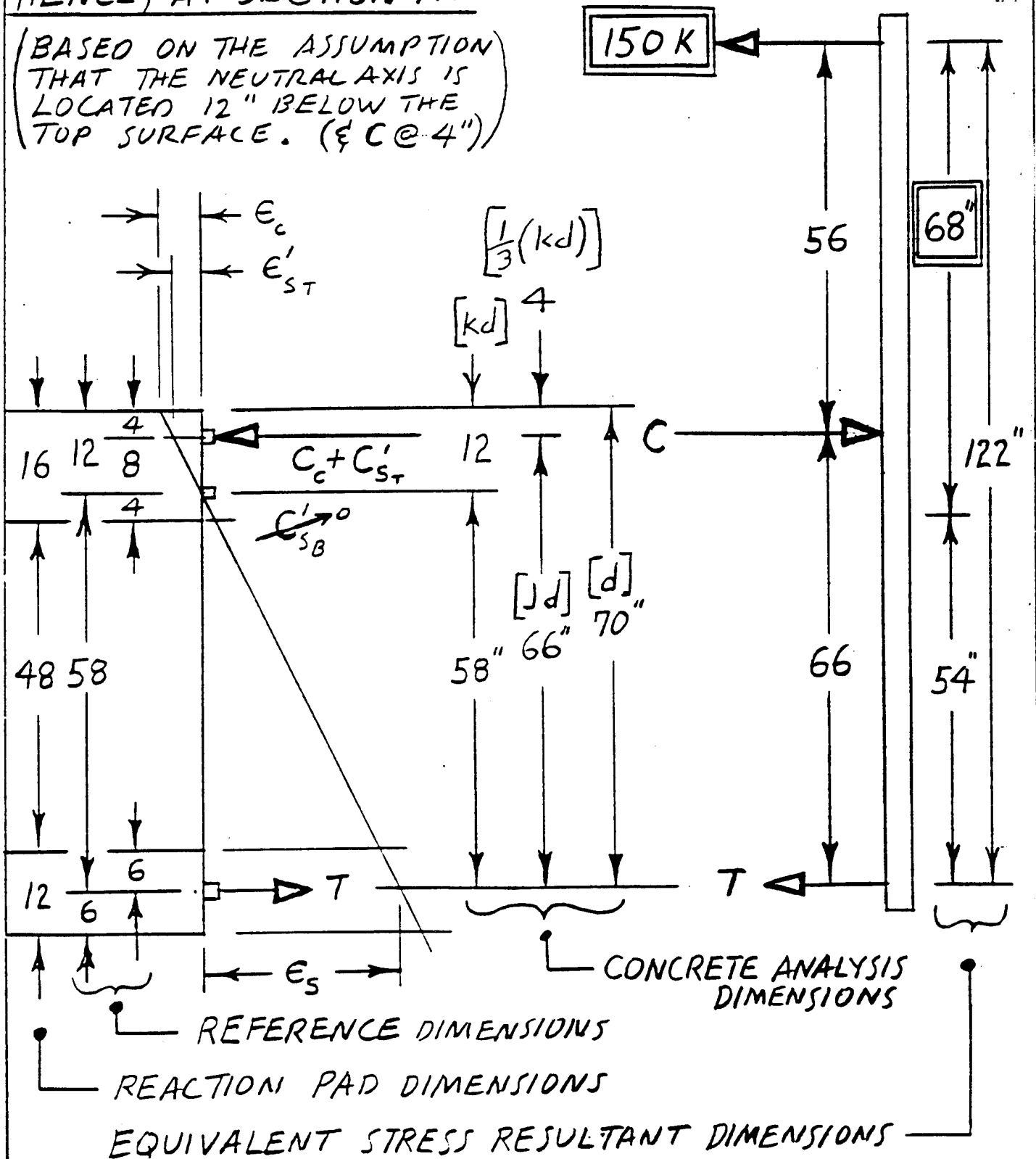

PROJECT IVCFBY [Signature]  
9/3/11

7

OF

SUBJECT REACTION PAD STRESSES

CKD

C

HENCE, IN TENSILE STEEL IN STEM (FOOTING):

$$T = T = \frac{56}{66} \times 150 = 127.3 \text{ K} \quad \textcircled{1}$$

TENSILE LOAD

$$A_s = 6 \times 1.56 \text{ IN}^2 = 9.36 \text{ IN}^2 \quad \textcircled{2}$$

AREA (6 #11 REBARS)

$$f_s = \frac{T}{A_s} = \frac{127.3}{9.36} = 13.60 \text{ KSI} \quad \textcircled{3}$$

TENSILE STRESS

$$\epsilon_s = \frac{f_s}{E_s} = \frac{13.6}{29 \times 10^3} = .000,469 \text{ IN/IN} \quad \textcircled{4}$$

ELONGATIONAL STRAIN

AND IN FLANGE (SLAB):

$$C = 150 + 127.3 = 277.3 \text{ K} \quad \textcircled{5}$$

TOTAL COMPRESSIVE FORCE

$$\frac{1}{2} f_c \times 12 \times 144 = C_c = C - C'_{ST}$$

CONCRETE STRESS VOLUME

$$f_c = \frac{C_c}{6 \times 144} \approx \frac{253.5 \text{ K}}{864 \text{ IN}^2} = .293 \text{ KSI} \quad \textcircled{6}$$

MAX CONCRETE STRESS (@ SURFACE)  
ASSUMING  $C'_{ST}$  IS SMALL ( $\approx 23.8 \text{ K}$ )

$$\epsilon_c = \frac{f_c}{E_c} = \frac{f_c}{3.2 \times 10^3} = .000,091,68 \text{ IN/IN} \quad \textcircled{7}$$

MAX CONCRETE STRAIN

$$\epsilon'_{ST} = \frac{8}{12} \epsilon_c = \frac{2}{3} \textcircled{7} = .000,061,12 \text{ IN/IN} \quad \textcircled{8}$$

MIN STEEL STRAIN

$$f'_{ST} = E_s \epsilon'_{ST} = 1.772 \text{ KSI} \quad \textcircled{9}$$

STEEL STRESS

$$A'_{ST} = 17 \times .79 = 13.43 \text{ IN}^2 \quad \textcircled{10}$$

STEEL AREA (17 #8)

$$C'_{ST} = f'_{ST} \times A'_{ST} = 23.8 \text{ K} \quad \textcircled{11}$$

COMPRESSIVE STEEL FORCE

CHECK THE ASSUMPTION THAT (C) IS LOCATED @ 4 IN.

$$k = \frac{\epsilon_c}{\epsilon_{ST} + \epsilon_c} = \frac{\textcircled{7}}{\textcircled{4} + \textcircled{8}} = .163,55 (-) \quad \textcircled{12}$$

$$kd = .163,55 \times 70 = 11.448'' \quad \text{VS ASSUMED } 12'' \text{ LOCATION}$$

$$[\frac{1}{3}(kd)] = 3.816'' \quad \text{VS ASSUMED } 4'' \text{ LOCATION}$$

HENCE, THE 4" ASSUMPTION WAS VERY CLOSE AND ITERATIVE REFINEMENT IS NOT NECESSARY. HOWEVER, ONE ITERATION WILL BE DONE FOR REFERENCE INFORMATION.



PROJECT IVCFBY [Signature]  
9/3/119  
OFSUBJECT REACTION PAD STRESSES

CKD

C

HENCE, IN TENSILE STEEL IN STEM (FOOTING):

$$T = T = \frac{56 \cdot 55.9}{66 \cdot 66.1} \cdot 150 = \frac{126.85}{1} K$$

TENSILE LOAD

$$A_s = 6 \times 1.56 \text{ IN}^2 = 9.36 \text{ IN}^2$$

AREA (6 #11 REBARS)

$$f_s = \frac{T}{A_s} = \frac{127.3}{9.36} = 13.60 \text{ KSI}$$

TENSILE STRESS

$$e_s = \frac{f_s}{E_s} = \frac{13.6}{29 \times 10^3} = .000469 \text{ IN/IN}$$

ELONGATIONAL STRAIN

AND IN FLANGE (SLAB):

$$C = 150 + \frac{126.85}{11.7} = 276.85 K$$

TOTAL COMPRESSIVE FORCE

$$\frac{1}{2} f_c \times 12 \times 144 = C_c = C - C'_{ST} + C'_{SB}$$

CONCRETE STRESS VOLUME

$$f_c = \frac{C_c}{6 \times 144} = \frac{253.3}{864 \text{ IN}^2} = .293 \text{ KSI}$$

MAX CONCRETE STRESS (@ SURFACE)  
ASSUMING,  $C'_{ST}$  IS SMALL ( $\approx 23.8 K$ )  
AND  $C'_{SB}$  IS VERY SMALL ( $\approx .52 K$ )

$$e_c = \frac{f_c}{E_c} = \frac{.293}{3.2 \times 10^3} = .00009168 \text{ IN/IN}$$

MAX CONCRETE STRAIN

$$e'_{ST} = \frac{8.77}{12 \cdot 11.7} e_c = .00006112 \text{ IN/IN}$$

TOP LAYER:  $\Sigma = 23.57 K$   
STEEL STRAIN (NOTE NEAR INVARIANCE)

$$f'_{ST} = E_s e'_{ST} = 1.77 \text{ KSI}$$

STEEL STRESS

$$A'_{ST} = 17 \times .79 = 13.43 \text{ IN}^2$$

STEEL AREA (17 #8)

$$C'_{ST} = f'_{ST} \times A'_{ST} = 23.8 K$$

COMPRESSIVE STEEL FORCE

$$e'_{SB} = \frac{3}{11.7} e_c = .00000241 \text{ IN/IN}$$

BOTTOM LAYER:  
STEEL STRAIN

$$f'_{SB} = E_s e'_{SB} = .07 \text{ KSI}$$

STEEL STRESS

$$A'_{SB} = 17 \times .44 = 7.48 \text{ IN}^2$$

STEEL AREA (17 #6)

$$C'_{SB} = f'_{SB} \times A'_{SB} = .52 K$$

TENSILE STEEL FORCE

CHECK THE FORCE IN THE CONCRETE.

$$C_c = C - C'_{ST} - C'_{SB} = 276.85 - 24.09 + .52 = 253.3 K \quad \checkmark \text{ } \approx \text{ } OK$$



PROJECT IVERBY 605  
93/1111  
OFSUBJECT REACTION PAD STRESSES

CKD

C

@ SECTION B: (SEE p. B-1, 2, & 3)

THIS IS THE CRITICAL SECTION FOR MAXIMUM NEGATIVE MOMENT THAT INDUCES THE MAXIMUM TENSILE LOAD IN THE RE-BARS THAT ARE IN THE FLANGE (i.e., THE LONGITUDINAL RE-BARS IN THE SLAB).

THE MAXIMUM AXIAL NORMAL TENSILE STRESS RESULTANT ( $M$ ) ALSO OCCURS SIMULTANEOUSLY AT THIS SECTION. THIS INDUCES ADDITIONAL TENSILE STRESSES IN ALL OF THE RE-BARS.

HENCE, AT THIS SECTION, THE SIMULTANEOUS COMBINATION OF MAXIMUM ( $M$ ) AND MAXIMUM ( $N$ ) GENERATES THE MAXIMUM TENSILE STRESS IN THE UPPER LAYER OF THE LONGITUDINAL RE-BARS IN THE FLANGE (SLAB).

THEREFORE, THIS SECTION GOVERN THE MAXIMUM AMOUNT OF FLANGE RE-BAR STEEL IN THE REACTION PAD. THE LOCATIONS OF THE "CUTOFF" POINTS WHERE THE FLANGE RE-BAR AREA MAY BE REDUCED MAY BE OBTAINED DIRECTLY FROM THE MOMENT DIAGRAM.

THE MAXIMUM COMPRESSIVE STRESS IN THE CONCRETE OCCURS IN THE STEM (FOOTING) AT THIS SECTION DUE TO THE MAXIMUM NEGATIVE MOMENT. NOTE THAT THE MAXIMUM TENSILE ( $N$ ) WILL TEND TO REDUCE THESE CONCRETE COMPRESSIVE STRESSES SOMEWHAT, BUT THEY WILL STILL BE MAXIMUM HERE.

THE MAXIMUM SHEAR ALSO OCCURS AT THIS SECTION (AS WELL AS AT SECTION A). HOWEVER, IT WILL BE MORE CRITICAL IN THE STEM AT SECTION A. SEE SECTION A DISCUSSION FOR ITS EFFECTS.



PROJECT \_\_\_\_\_

BY WJ

12

/93/11

OF

SUBJECT REACTION PAD STRESSES

CKD \_\_\_\_\_

C

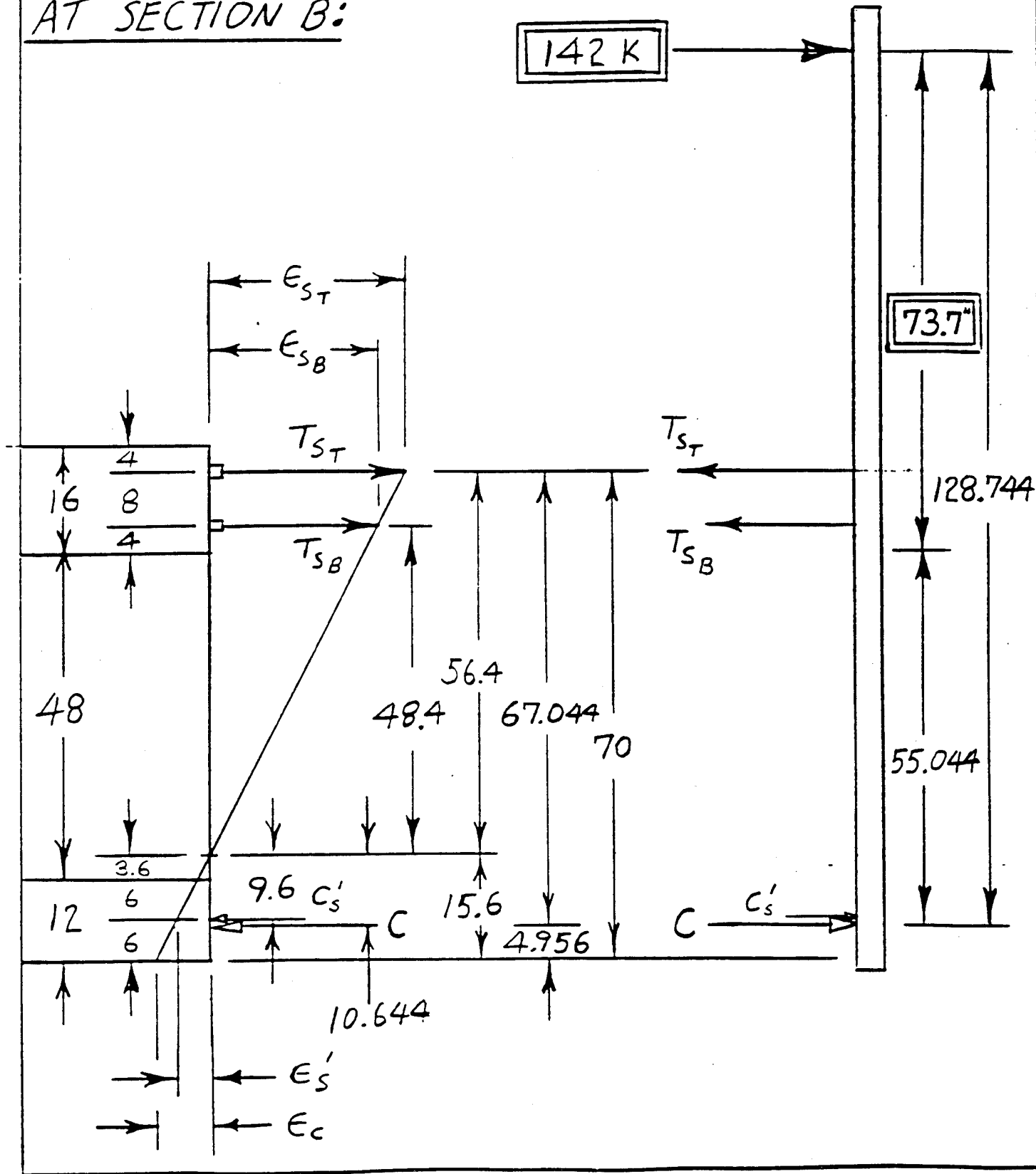
AT SECTION B:



PROJECT	I VEF	BY	10/11 (193/11)	13 OF
SUBJECT	REACTION PAD STRESSES	CKD		C

CONCRETE COMPRESSIVE STRESS VOLUME DIAGRAM:

$$\begin{aligned}
 \text{VOL} \times \text{DIST} &= \text{MOM} \\
 \Sigma (123) & \quad \Sigma (124) \\
 \frac{1}{2} \times 3.6 \times 3.6 \times 16 &= 104 \times 13.2 = 1369 \\
 3.6 \times 12 \times 36 &= 1555 \times 6 = 9331 \\
 \frac{1}{2} \times 12 \times 12 \times 36 &= 2592 \times 4 = 10,368 \\
 4251 @ 4.956 &= 21,068
 \end{aligned}$$

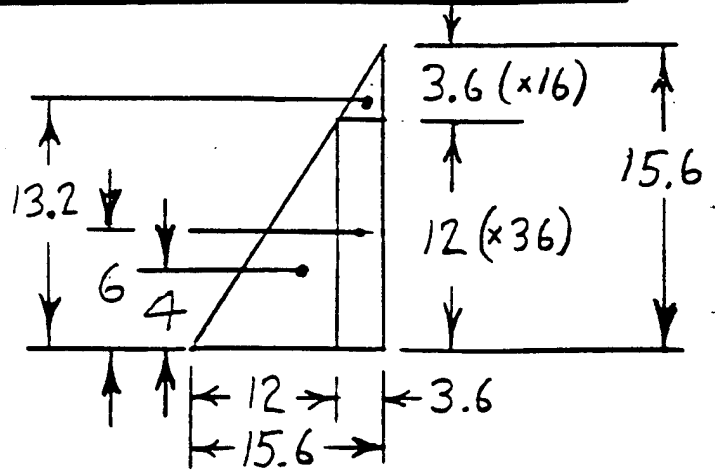

EXPRESS ALL STEEL FORCES IN TERMS OF  $T_{ST}$ :

$$T_{SB} = \left( \frac{48.4}{56.4} \right) \left( \frac{17 \times .44}{17 \times .79} \right) T_{ST} = .477,96 T_{ST} \quad (61)$$

$$C'_S = \left( \frac{9.6}{56.4} \right) \left( \frac{6 \times 1.56}{17 \times .79} \right) T_{ST} = .118,63 T_{ST} \quad (62)$$

$$\Sigma M_c = 0:$$

$$67.044 T_{ST} + 59.044 T_{SB} - 1.044 C'_S = 142 \times 128.744$$

$$[67.044 + 59.004 \times .477,96 - 1.044 \times .118,63] T_{ST} = 142 \times 128.744$$

$$\Sigma F_x = 0: \quad T_{ST} = 192.15^+ K \quad (63)$$

$$T_{ST} = 192.15 K \div (17 \times .79) = 14.31 \text{ Ksi} = f_{ST} \div 29,000 = .000,493,4 = \epsilon_{ST} \quad (67)$$

$$+T_{SB} = 91.84 K \div (17 \times .44) = 12.28 \text{ Ksi} = f_{SB} \div 29,000 = .000,423,4 = \epsilon_{SB} \quad (64)$$

$$-C'_S = -22.79 K \div (6 \times 1.56) = 2.44 \text{ Ksi} = f'_S \div 29,000 = .000,084,0 = \epsilon'_S \quad (65)$$

$$C = 119.2 K \quad (C \text{ BASED ON EQUILIBRIUM}) \quad (66)$$

(C BASED ON STRESS BLOCK VOLUME)

$$\left( \frac{15.6}{56.4} \right) \epsilon_{ST} = .000,136,5 = \epsilon_c \times 3200 = .4367 \text{ Ksi} = f_c \times \left( \frac{4251}{15.6} \right) = 119.0 K = C \quad (68)$$



PROJECT		BY	14
		193/11	OF
SUBJECT	REACTION PAD STRESSES	CKD	C

THERE IS EXCELLENT AGREEMENT BETWEEN THE CONCRETE COMPRESSIVE FORCE (C) BASED ON EQUILIBRIUM AND THAT BASED ON STRESS BLOCK VOLUME. THEREFORE, THE NEUTRAL AXIS IS AT ITS PROPER LOCATION AND ALL THE CALCULATED VALUES ARE VALID.

NOTE THAT IF THE COMPRESSIVE FORCE (C) BASED ON STRESS BLOCK VOLUME WAS LARGER THAN THAT NECESSARY FOR EQUILIBRIUM IT WOULD MEAN THE CONCRETE STRAINS AND STRESSES WERE TOO LARGE BECAUSE THE NEUTRAL AXIS WAS TOO FAR FROM THE CONCRETE COMPRESSIVE SURFACE. CONSEQUENTLY, THE NEUTRAL AXIS SHOULD BE SHIFTED NEARER TO THE CONCRETE SURFACE. VICE-VERSA IF THE STRESS VOLUME (C) IS SMALLER THAN THE EQUILIBRIUM (C).

### IN SUMMARY (@ SECTION B):

THE STRESS IN THE CONCRETE IS ABOUT:

$$f_c = 440 \text{ psi} \quad \% \text{ OK } \left( \approx 32\% \text{ OF THE ACI ALLOWABLE} \right. \\ \left. \text{STRESS OF } .45 f'_c = 1350 \text{ psi} \right)$$

THE STRESS IN THE TENSILE RE-BAR STEEL IS ABOUT:

$$f_s = 14.3 \text{ ksi} \quad \% \text{ OK } \left( \approx 72\% \text{ OF } 20 \text{ ksi } (F_y \text{ FOR GRADE 40}) \right. \\ \left. \approx 60\% \text{ OF } 24 \text{ ksi } (F_y \text{ FOR GRADE 60}) \right)$$

THE STRESS IN THE COMPRESSION STEEL IS ABOUT:

$$f'_s = 2.4 \text{ ksi} \quad \% \text{ OK } \left( \text{NO CONCERN ABOUT LATERAL} \right. \\ \left. \text{RESTRAINT.} \right)$$

PROJECT IVCFBY [Signature] 15  
9/3/11 OFSUBJECT REACTION PAD STRESSES

CKD C

## STRESSES IN KEY FOOTING: (SEE p B-4)

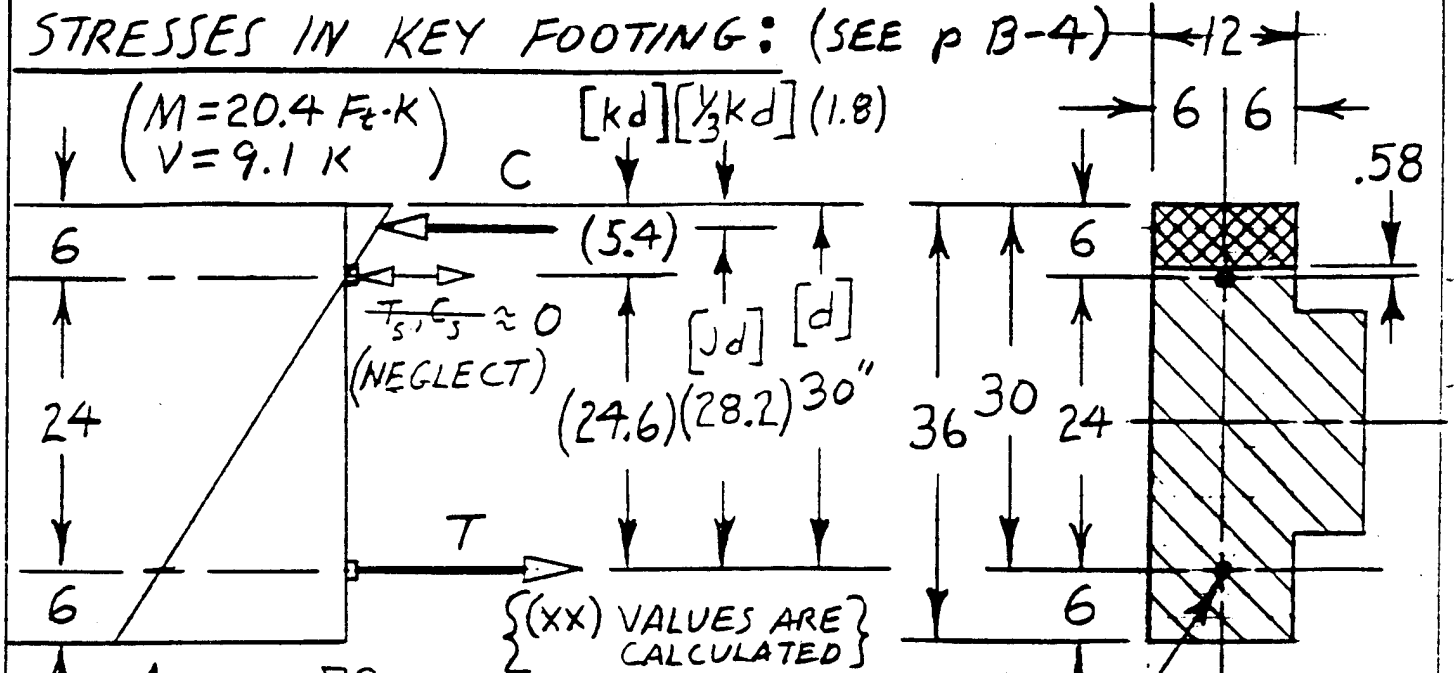

$$P = \frac{A_s}{bd} = \frac{.79}{12 \times 30} = .00219 (-) \text{ STEEL RATIO} \quad \textcircled{91}$$

$$n = \frac{E_s}{E_c} = \frac{29,000}{3,200} = 9.0625 (-) \text{ MODULAR RATIO} \quad \textcircled{92}$$

$$pn = \textcircled{91} \times \textcircled{92} = .01989 (-) \text{ STIFFNESS RATIO} \quad \textcircled{93}$$

$$k = \sqrt{2(pn) + (pn)^2} - (pn) = .1805 (-) \quad kd = 5.416 \text{ IN} \quad \textcircled{94} \quad \textcircled{95}$$

$$\left[ \frac{k}{3} \right] = .0602 (-) \quad \frac{1}{3} kd = 1.805 \text{ IN} \quad \textcircled{96} \quad \textcircled{97}$$

$$J = 1 - \frac{k}{3} = .9398 (-) \quad Jd = 28.195 \text{ IN} \quad \textcircled{98} \quad \textcircled{99}$$

$$T = \frac{M}{Jd} = \frac{20.4 \times 12}{28.195} = 8.683 \text{ K} \quad \textcircled{100}$$

$$f_s = \frac{T}{A_s} = \frac{8.683}{.79} = 11.0 \text{ KSI} = f_s \quad \textcircled{101} \quad \textcircled{\circ} \text{ OK} \quad \left( \begin{array}{l} \approx 55\% \text{ OF } 20 \text{ KSI FOR } 6040 \\ \approx 46\% \text{ OF } 24 \text{ KSI FOR } 6060 \end{array} \right)$$

$$f_c = \frac{2P}{k} f_s = 267 \text{ PSI} = f_c \quad \textcircled{102} \quad \textcircled{\circ} \text{ OK} \quad (\approx 20\% \text{ OF } 1350 \text{ PSI})$$

$$v = \frac{V}{bJd} = \frac{9,100}{12 \times \textcircled{99}} = 27 \text{ PSI} = v \quad \textcircled{103} \quad \textcircled{\circ} \text{ OK}$$



PROJECT

DATE 9/93/11

10 OF

SUBJECT REACTION PAD STRESSES

CKD

C

## STRESSES IN KEY WALL: (SEE PB-6)

$$\begin{aligned} (M &= 4.2 \text{ Ft}\cdot\text{K}) \\ (V &= 2.0 \text{ K}) \end{aligned}$$

$$[kd] [\frac{1}{3} kd] (1.0)$$

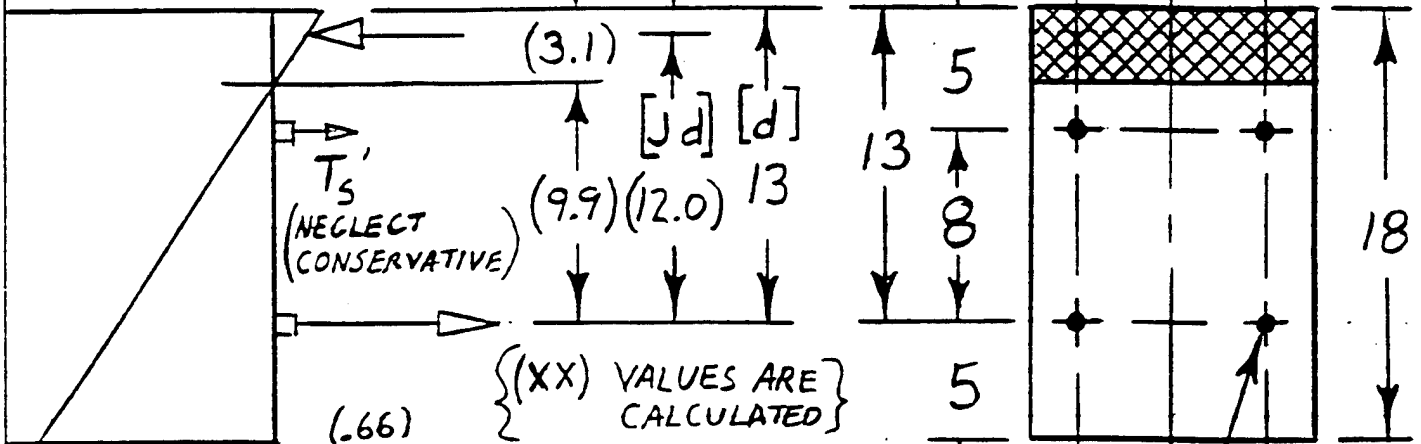

$$\rho = \frac{A_s}{bd} = \frac{(\frac{12}{8}) \times 44}{12 \times 13} = .004, 23 \text{ (-) STEEL RATIO} \quad \#6 @ 8''$$

$$n = \frac{E_s}{E_c} = \frac{29,000}{3200} = 9.0625 \text{ (-) MODULAR RATIO}$$

$$\rho n = .038, 34 \text{ (-) STIFFNESS RATIO}$$

$$k = \sqrt{2(\rho n) + (\rho n)^2} - (\rho n) = .2412 \text{ (-) } kd = 3.136 \text{ IN}$$

$$[k/3] = .0804 \text{ (-) } \frac{1}{3} kd = 1.045 \text{ IN}$$

$$j = 1 - \frac{k}{3} = .9196 \text{ (-) } jd = 11.955 \text{ IN}$$

$$T = \frac{M}{jd} = \frac{4.2 \times 12}{11.955} = 4.216 \text{ K}$$

$$f_s = \frac{T}{A_s} = \frac{4.22}{.66} = 6.4 \text{ KSI} = f_s \quad \text{OK } (\approx 32\% \text{ OF } 20 \text{ KSI } 6040)$$

$$f_c = \frac{2P}{k} f_s = 224 \text{ PSI} = f_c \quad \text{OK } (\approx 17\% \text{ OF } 1350 \text{ PSI})$$

$$v = \frac{V}{bdj} = \frac{2000}{12 \times .99} = 14 \text{ PSI} = v \quad \text{OK}$$



PROJECT	IVET	BY	DD 193/11	1 OF
SUBJECT	REACTION PAD UNIVERSAL MOUNTING RAILS	CKD		D

FOR USUAL CONCRETE STRUCTURES IN WHICH THE RE-BAR STEEL IS EMBEDDED IN THE CONCRETE, AND HENCE AT THE SAME TEMPERATURE AS THE CONCRETE, THERE ARE NO PROBLEMS WITH DIFFERENTIAL THERMAL EXPANSION BETWEEN THE STEEL AND THE CONCRETE BECAUSE THE STEEL AND THE CONCRETE HAVE ABOUT THE SAME COEFFICIENT OF THERMAL EXPANSION.

HOWEVER, THE UNIVERSAL MOUNTING RAILS IN THE REACTION PAD HAVE EXPOSED FLANGES THAT CAN BE AT A SIGNIFICANTLY DIFFERENT TEMPERATURE THAN THE CONCRETE. PARTICULARLY ON A BRIGHT SUNNY DAY. THE TEE BEAM FLANGE CAN GET MUCH HOTTER THAN THE CONCRETE IN WHICH IT IS EMBEDDED, HENCE, THE TEE BEAM WANTS TO EXPAND LONGITUDINALLY (AND BOW UPWARD AT THE CENTER) WITH RESPECT TO THE CONCRETE IN WHICH IT IS EMBEDDED. NOTE THIS IS NO PROBLEM FOR NORMAL RAILS IN/ON CONCRETE BECAUSE THE RAILS ARE SIMPLY HELD IN PLACE BY CLEATS WHICH ALLOW THE RAILS TO SLIP LONGITUDINALLY BUT PREVENT THE RAILS FROM BOWING VERTICALLY. HOWEVER, THIS IS NOT ADMISSIBLE FOR THE RAILS CAN NOT SLIP AXIALLY BECAUSE THEIR FUNCTION IS TO TRANSFER LONGITUDINAL LOADING ON THE RAILS DIRECTLY INTO THE CONCRETE REACTION PAD.

TO SECURELY ANCHOR THE RAILS IN THE CONCRETE AND ASSURE STRAIN COMPATIBILITY (NO DIFFERENTIAL DISPLACEMENT BETWEEN THE RAIL AND THE CONCRETE) EACH RAIL MUST BE SECURELY ANCHORED AT ITS ENDS.

THIS REQUIRED END ANCHORAGE IS FURNISHED BY THE 2 INCH DIAMETER BARS AT THE END OF EACH RAIL. THIS ANCHORS THE RAILS FOR UP TO ABOUT A 70 °F  $\Delta T$ .



PROJECT IVEF

BY UOT  
93/112  
OFSUBJECT REACTION PAD UNIVERSAL  
MOUNTING RAILS

CKD

D

IN ADDITION TO THE 2 $\phi$  BARS AT EACH END OF EACH RAIL TO ANCHOR THE RAILS TO THE CONCRETE TO PREVENT RELATIVE LONGITUDINAL DISPLACEMENT BETWEEN THE RAILS AND THE CONCRETE WHEN THE RAILS AND THE CONCRETE ARE AT DIFFERENT TEMPERATURES THERE ARE HEADED STUDS ALONG THE RAIL TO TRANSFER SHEAR BETWEEN THE RAILS AND THE CONCRETE.

THERE ARE 18 PAIRS OF 3/4 $\phi$  x 6" STUDS ALONG EACH RAIL ON 10 INCH CENTERS. THE ACI ALLOWABLE SHEAR LOAD PER PAIR OF SUCH HEADED STUDS IS 23 K.

THEREFORE, THE SHEAR LOAD TRANSFER AVAILABLE PER RAIL IS  $18 \times 23 = 414$  K THROUGH THE LUGS ALONE (ADDITIONAL CAPACITY IS AVAILABLE THROUGH THE 2 $\phi$  END BARS AND BOND BETWEEN THE STEEL STEM AND THE CONCRETE, ETC.).

THE DISTRIBUTION OF SHEAR TRANSFER FOR THE 400 K REACTION TRUSS IS, OF COURSE, DESIGN SPECIFIC, BUT THESE SHEAR LUG CONNECTORS SHOULD BE ADEQUATE.

NOTE THAT THE LARGER 7/8 $\phi$  x 6" SHEAR LUG CONNECTORS COULD BE USED AS WELL AS ALTERNATE SPACINGS. THESE LARGER LUGS HAVE A CAPACITY OF 31 K PER PAIR OF CONNECTORS. THIS WOULD RESULT IN AN AVAILABLE SHEAR CAPACITY OF  $18 \times 31 = 558$  K PER RAIL AT THE SAME 10" SPACING.



PROJECT LEVEL

BY YDS  
93/11

1  
OF

SUBJECT REACTION TRUSS LOADS,  
STRESS RESULTANTS, AND STRESSES

CKD

E

LOADS AND STRESS RESULTANTS:

NORMALIZE THE REACTION LOAD TO 100 K:

(50 K PER SIDE)

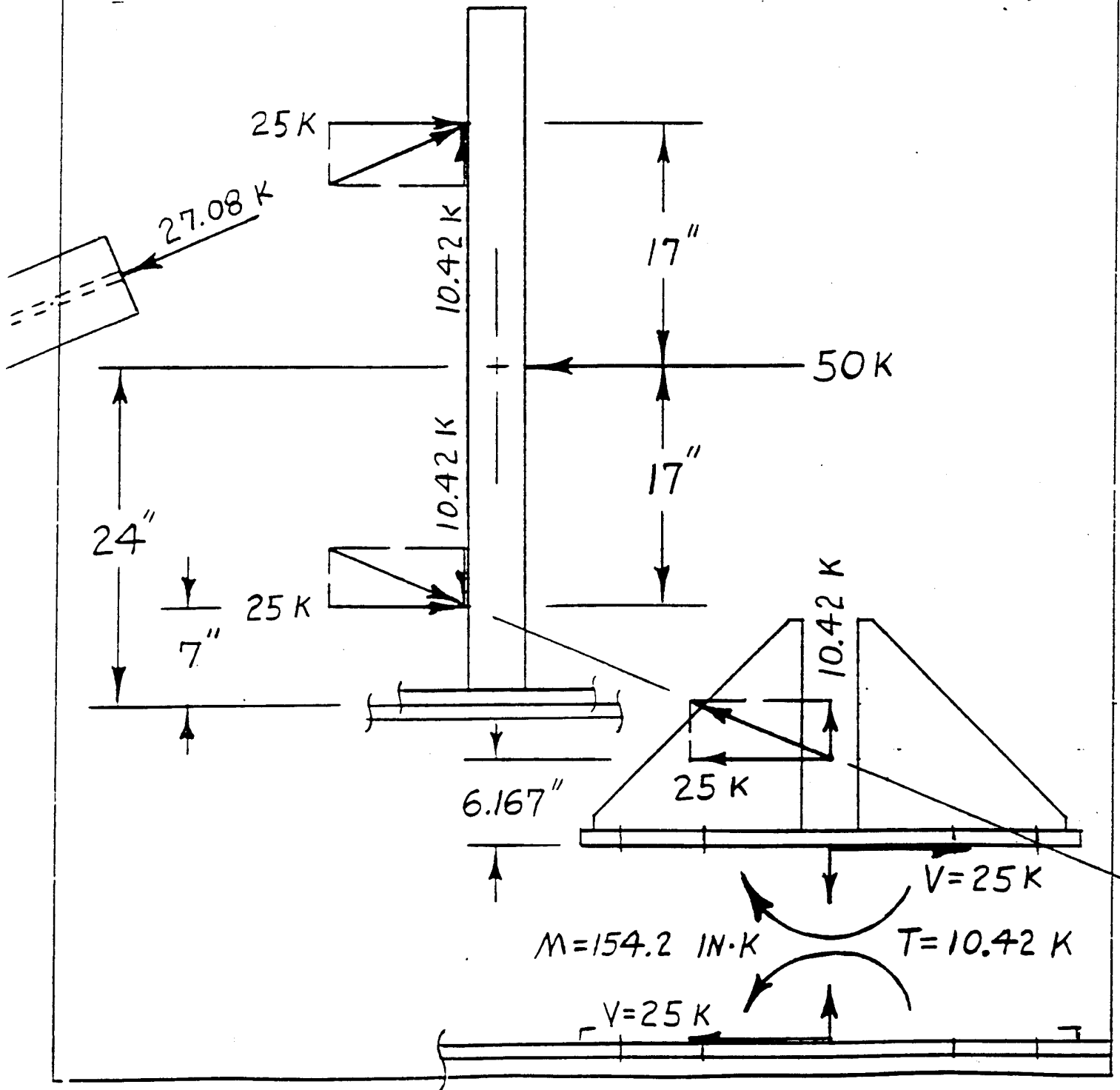



PROJECT TVEF

BY YDP 2 OF  
9/3/11

SUBJECT REACTION TRUSS LOADS,  
STRESS RESULTANTS, AND STRESSES

CKD — E

### REACTION TRUSS LOADS:

NORMALIZE THE TRUSS REACTION LOAD TO 100 K.  
(DUE TO VERTICAL LONGITUDINAL PLANE OF SYMMETRY, HALF THE LOAD IS SUPPORTED BY EACH SIDE.)

- THE NOMINAL MAXIMUM THRUST LOAD IS 92 K
- THE EXTREME MAXIMUM THRUST LOAD IS 300 K

### DIAGONAL STRUT IN REACTION TRUSS:

THE APPLIED AXIAL COMPRESSIVE INTERNAL LOAD (STRESS RESULTANT (N)) IS

- 27.1 K @ NORMALIZED 100 K LOAD
- 24.9 K @ 92 K THRUST LOAD
- 81.3 K @ 300 K THRUST LOAD

### THE DIAGONAL STRUT IS A W 6x25:

THE ALLOWABLE COLUMN LOAD IS BASED ON AISC'S ALLOWABLE LOADS BASED ON THE EFFECTIVE COLUMN SLENDERNESS RATIOS ( $\frac{KL}{r}$ ) FOR EACH OF THE TWO ORTHOGONAL PRINCIPAL AXES (XX & YY).

THE AXIS WHICH HAS THE LARGEST SLENDERNESS RATIO ( $\frac{KL}{r}$ ) HAS THE LOWEST ALLOWABLE AXIAL COMPRESSIVE LOAD AND THEREFORE GOVERNS THE ALLOWABLE LOAD.

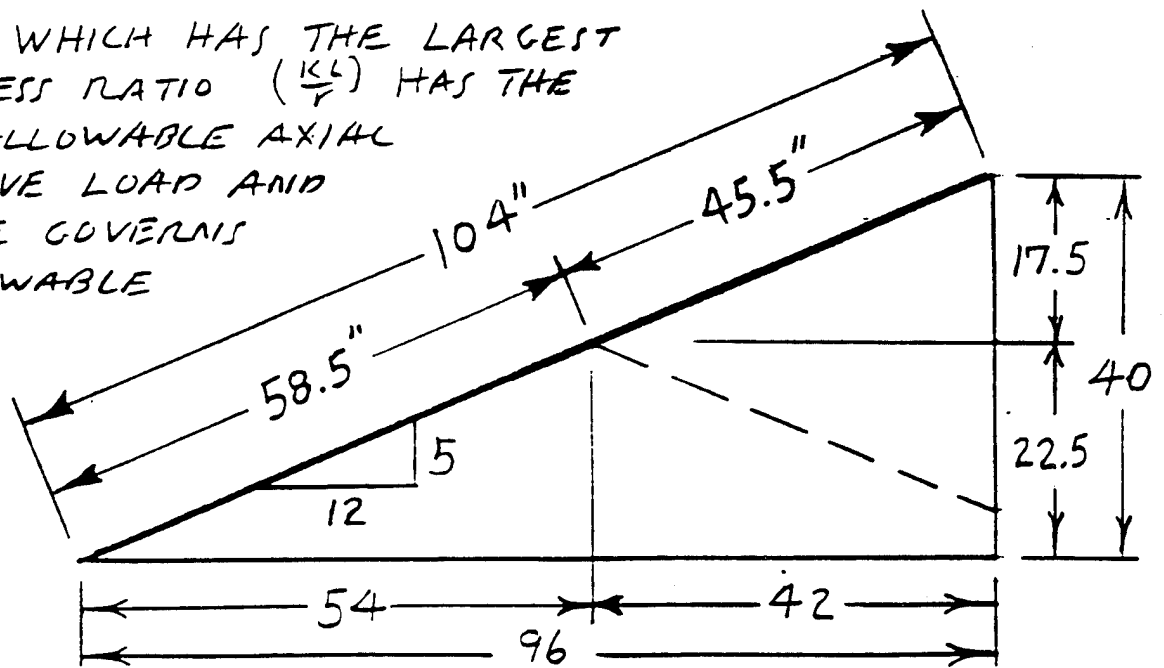



PROJECT TVEF

BY YJS  
9/3/113  
OFSUBJECT REACTION TRUSS LOADS,  
STRESS RESULTANTS, AND STRESSES

CKD

E

ABOUT THE STRONG (XX) AXIS ( $\frac{KL}{r}$ ) WILL NOT EXCEED:

$$\left(\frac{KL}{r}\right) = \frac{.6 \times 104}{2.70} = 23.1$$

ABOUT THE WEAK (YY) AXIS ( $\frac{KL}{r}$ ) WILL NOT EXCEED:

$$\left(\frac{KL}{r}\right) = \frac{.8 \times 58.5}{1.52} = 30.8$$

THE (YY) AXIS GOVERNS. SO THE MAXIMUM ALLOWABLE AXIAL COMPRESSIVE STRESS IS:

$$F_a = \left\{ \begin{array}{l} 19.9 \text{ ksi (FOR A-36 STEEL)} \\ 27.1 \text{ ksi (FOR 50 KSI STEELS)} \end{array} \right\}$$

USING A-36 STEEL THE ALLOWABLE LOAD IN THE STRUT IS:

$$P_a = A \times F_a = 7.34 \text{ in}^2 \times 19.9 \text{ k/in}^2 = 146 \text{ k}$$

$$P_a = 146 \text{ k}$$

HENCE THE COMPRESSIVE LOAD IN THE STRUT IS:

17 % OF THE ALLOWABLE (AT THE NOMINAL LOAD OF 92K)

19 % OF THE ALLOWABLE (AT THE NORMALIZED LOAD OF 100K)

56 % OF THE ALLOWABLE (AT THE MAXIMUM LOAD OF 300K)



PROJECT TVEF

BY AB 4  
93/11 OF

SUBJECT REACTION TRUSS LOADS,  
STRESS RESULTANTS, AND STRESSES.

CKD      E

SHEAR STANCHION:

1 1/8" BOLTS WILL BE PLACED IN OVERSIZED HOLES (e.g., 1 7/16" HOLES) SO THAT THE LOADS WILL BE TAKEN IN DIRECT TENSION AND SHEAR FRICTION. THE BOLT PRELOAD TENSION WILL BE GREAT ENOUGH THAT THE CLAMPED FRICTION PREVENTS ANY RELATIVE MOVEMENT. THIS IS STANDARD PRACTICE IN AISC BOLTED FRICTION JOINTS. USING STANDARD STRUCTURAL BOLTS (IE. A325 OR A490).

A325	A490	TYPE OF STRUCTURAL BOLT
56 K	80K	MINIMUM REQUIRED BOLT PRELOAD TENSION.
15 K	19 K	MINIMUM ALLOWABLE SHEAR FRICTION LOAD

SERVICE LOADS:

SHEAR: (EIGHT BOLTS & NORMALIZED 100 K THRUST)

$V = \frac{25}{8} = 3.125$

$V = 3.1 K \approx OK$

(@ NORMALIZED 100 K THRUST)

}	19%	@ 92K	} A 325 BOLTS
	21% OF ALLOWABLE	@ 100K	
}	63%	@ 300K	} A 490 BOLTS
	15%	@ 92K	
}	17% OF ALLOWABLE	@ 100K	}
	50%	@ 300K	

USE 1 1/8" A 325 BOLTS

APPLY A MINIMUM PRELOAD TENSION OF 56 K/BOLT. (e.g., TORQUE TO ABOUT 1000 Ft.-#)

NOTE THAT:

A 325 STRUCTURAL BOLTS ARE ABOUT GRADE 5  
A 490 STRUCTURAL BOLTS ARE ABOUT GRADE 8



PROJECT TVEF

BY NB  
198/11

5  
OF

SUBJECT REACTION TRUSS LOADS,  
STRESS RESULTANTS, AND STRESSES

CKD

E

TENSION & MOMENT COMBINATION:

TENSION:

$$T_p = \frac{T}{8} = \frac{10.42}{8} = 1.302 \text{ K} \quad (7)$$

$$T_p = 1.302 \text{ K}$$

MOMENT:

$$15 \times 4 T_{M_o} + 9 \times 4 T_{M_i} = 154.2$$

$$60 T_{M_o} + 36 \left(\frac{9}{15} T_{M_o}\right) = 154.2$$

$$T_{M_o} = \frac{154.2}{60 + 21.6} = 1.889 \text{ K} \quad (8)$$

$$T_{M_i} = \frac{9}{15} T_{M_o} = 1.134 \text{ K} \quad (9)$$

$$T_{M_o} = 1.889 \text{ K}$$

$$T_{M_i} = 1.134 \text{ K}$$

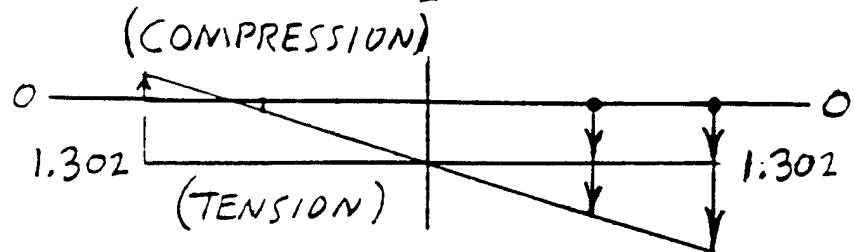
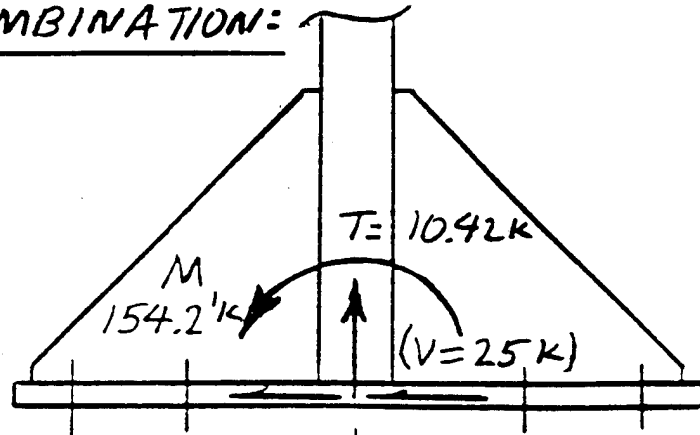

BOLT TENSION DUE TO T                      1.302   1.302                      1.302   1.302

BOLT TEN/COMP DUE TO M                -1.889 -1.134                      +1.134 + 1.889

CHANGE IN BOLT SYSTEM                - .587 + 0.169                      + 2.436 + 3.191 K

LOAD DUE TO THRUST LOAD                (10) (11)                      (12) (13)  
(SMALL COMPARED TO MIN PRELOAD OF 56 K)

IN ANY BOLT SYSTEM (CONSISTING OF A BOLT CLAMPING SURROUNDING MATERIAL) A CERTAIN PORTION OF THE APPLIED LOAD IS CARRIED BY THE SURROUNDING MATERIAL (NOMINALLY 90% TO 70%) AND THE REMAINDER (NOMINALLY 10% TO 30%) IS CARRIED BY THE BOLT ITSELF. THE LOAD DISTRIBUTION IS A FUNCTION OF THE RELATIVE STIFFNESS BETWEEN THE TWO. FOR EXAMPLE, IN A WELL DESIGNED SYSTEM (IN THE ABSENCE OF PRYING) THE BOLT ITSELF SHOULD TAKE ONLY ABOUT 10% OF THE VARIATIONAL LOAD. (BEWARE OF PRYING THAT CAN MAGNIFY BOLT LOADING).

PROJECT TVEFBY WJ  
9/3/111  
OFSUBJECT EXPANSION TUBE LOADS,  
STRESS RESULTANTS, & STRESSES

CKD. \_\_\_\_\_

F

BASIC TUBE: (30" OD x .25 WALL)AREA: ( $A = \pi(r_o^2 - r_i^2) \equiv \pi(D-t)t$ ) WEIGHT PER FT.

$$A = \pi(29.75) \cdot 25 = \boxed{23.37 \text{ IN}^2 = A} \times 3.4 = \boxed{79.44 \#/\text{FT} = W_t}$$

MOM. OF INERTIA: ( $I = \frac{\pi}{4}(r_o^4 - r_i^4)$ ) SECTION MODULUS

$$I = \frac{\pi}{4}(15^4 - 14.75^4) = \boxed{2585.2 \text{ IN}^4 = I} \div 15 = \boxed{172.35 \text{ IN}^3 = S}$$

\*

REACTION FRAME LONGERONS: (PAIR OF W12x26 ON 34" CENTER)FOR LOADING IN THE VERTICAL PLANE:

$$I_x = 2I_{xx} = 2 \times 204 = \boxed{408 \text{ IN}^4 = I_x} \quad 2 \times 26 = \boxed{52 \#/\text{FT} = W_w}$$

$$\text{TOTAL} \leq \boxed{2993 \text{ IN}^4 = I_{xx}} \quad \boxed{132 \#/\text{FT} = W_s}$$

FOR LOADING IN THE HORIZONTAL PLANE:

$$I_y = 2[I_{yy} + Ad^2]$$
$$= 2[17.3 + 7.65 \times 17^2] = \boxed{4456 \text{ IN}^4 = I_y}$$

$$\text{TOTAL} \leq \boxed{7041 \text{ IN}^4 = I_{yy}}$$

$$\text{NOTE: } \sigma_{\text{WALL}} = \frac{Pr}{t} = \frac{35 \times 15}{0.25} = 2100 \text{ (VERY LOW)}$$

\* NOTE THAT THE ADDITION OF THESE LONGERONS IS NOT REALLY NECESSARY. THE 1/4" WALL PIPE IS ITSELF ADEQUATE IF PROPER ATTENTION IS PAID TO THE DETAILS OF THE SUPPORTS.  
o COMPLETE CALCULATIONS WITHOUT THESE LONGERONS.



PROJECT \_\_\_\_\_

BY UOY  
U93/11

2  
OF

SUBJECT EXPANSION TUBE LOADS,  
STRESS RESULTANTS, AND STRESSES

CKD \_\_\_\_\_

F

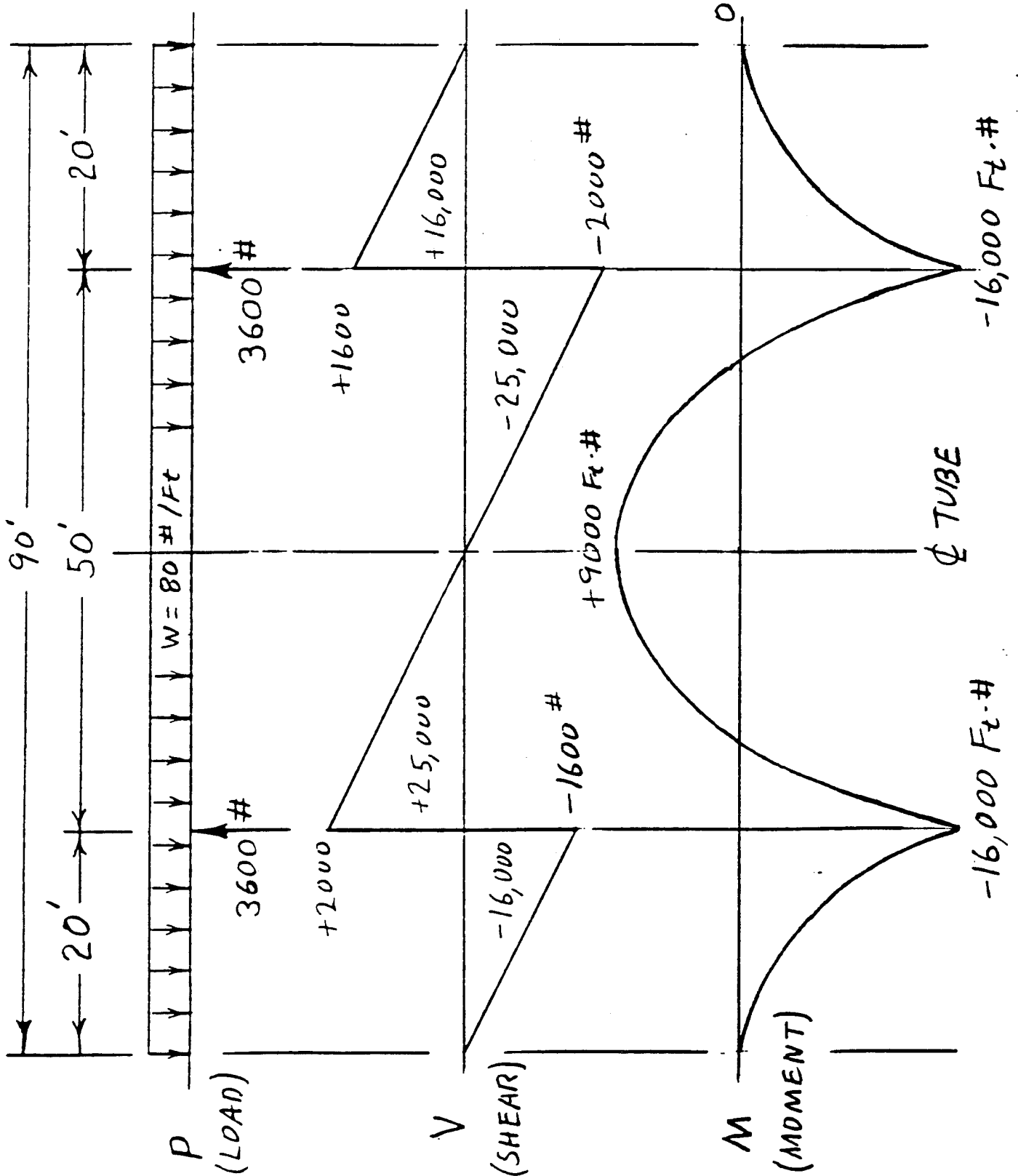

PROJECT TVEFBY AB

3

93/11

OF

SUBJECT EXPANSION TUBE LOADS  
STRESS RESULTANTS AND STRESSES

CKD

F

WIND LOADING:MAXIMUM WIND VELOCITY:

$$V_{\max} = 30 \text{ MPH} = 44 \text{ FPS}$$

REYNOLDS NUMBER:

$$R_e = \frac{\rho V L}{\mu} = \frac{.002378 (\text{SLUGS}/\text{FT}^3) \times 44 (\text{FT}/\text{SEC}) \times 2.5 (\text{FT})}{39.16 \times 10^{-8} (\text{SLUGS}/\text{FT} \cdot \text{SEC})}$$

$$R_e = 6.68 \times 10^5$$

AT THIS REYNOLDS NUMBER THE DRAG COEFFICIENT IS "DOWN IN THE NOTCH" FOR CIRCULAR CYLINDERS. THEREFORE USE A DRAG COEFFICIENT OF

$$C_D = .5 (-) \quad (\text{DRAG COEFFICIENT})$$

DRAG FORCE:

$$F = C_D \frac{\rho V^2 A}{2} = \frac{.5}{2} .002378 \times 44^2 \times (2.5 \times 1) = 2.88 \text{ \#/FT}$$

$$F = 3 \text{ \#/FT} \quad (\text{VERY LOW - ABOUT 3.6\% OF THE DEAD WEIGHT LOADING})$$

HENCE, FOR THE WIND LOADING JUST USE 3.6% OF THE DEAD WEIGHT:

- LOADING
- STRESS RESULTANTS
- STRESSES

AS THE CORRESPONDING WIND INDUCED ITEMS ACTING IN ORTHOGONAL PLANES.

PROJECT TVEFBY AB  
9/3/114  
OFSUBJECT EXPANSION TUBE LOADS,  
STRESS RESULTANTS, AND STRESSES

CKD

F

CALCULATE CRITICAL BUCKLING STRESS IN TUBE WALL

$$\sigma_{cr} = \frac{E}{(1-\nu^2)\pi} \left( \frac{t}{r} \right) = \frac{29,000}{(1-.3^2)\pi} \left( \frac{.25}{15} \right) = 169 \text{ ksi}$$

$$\sigma_{cr} = 169 \text{ ksi} \quad \text{OK} \quad \left( \begin{array}{l} \text{ALMOST 5 TIMES YIELD OF 36 OR 35} \\ \text{ALMOST 8 TIMES MAX ALLOWABLE} \end{array} \right)$$

CALCULATE THE DEFLECTIONS AT MIDSPAN:

$$\delta = \frac{5}{384} \frac{WL^4}{EI} - \frac{(M_1)_L^2}{8EI} \quad M_1 = \frac{W(\frac{2}{3}L)^2}{2} \Rightarrow \frac{2}{25} WL^2 \frac{L^2}{8EI} \frac{48}{48}$$
$$= \left( 5 - \frac{96}{25} \right) \frac{1}{384} \frac{WL^4}{EI} = \frac{29}{9600} \frac{WL^4}{EI}$$

$$\delta = \frac{29}{9600} \frac{WL^4}{EI} = \frac{29}{9600} \frac{(80/12) \#/\text{IN} \times (50 \times 12)^4 \text{ IN}^4}{29 \times 10^6 \#/\text{IN}^2 \times 2585 \text{ IN}^4} = .0348''$$

$$\delta = .035 \text{ IN}$$

DEFLECTION @ MIDSPAN DUE TO DEAD LOAD WEIGHT.



PROJECT TVEF

BY 1/10/93  
1/93/11

5  
OF

SUBJECT EXPANSION TUBE LOADS,  
STRESS RESULTANTS, & STRESSES

CHKD

F

STRESSES AT MIDSPAN:

$$f_b = \frac{M}{S} = \frac{9000 \times 12 \text{ IN}^\#}{172 \text{ IN}^3} = 627 \text{ psi} = .63 \text{ ksi}$$

$f_b = 627 \text{ psi}$  GRAVITY LOADING  
 $23 \text{ psi}$  WIND LOADING

STRESSES AT SUPPORTS:

$$f_b = \frac{M}{S} = \frac{16,000 \times 12}{172} = 1114 \text{ psi} = 1.11 \text{ ksi}$$

$f_b = 1114 \text{ psi}$  GRAVITY LOADING  
 $40 \text{ psi}$  WIND LOADING

SUMMARY OF STRESSES IN TUBE:

AT MIDSPAN: (psi)      AT SUPPORTS:

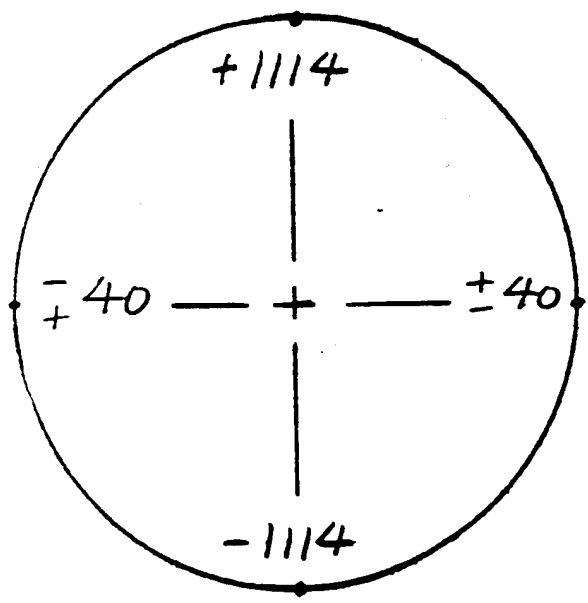
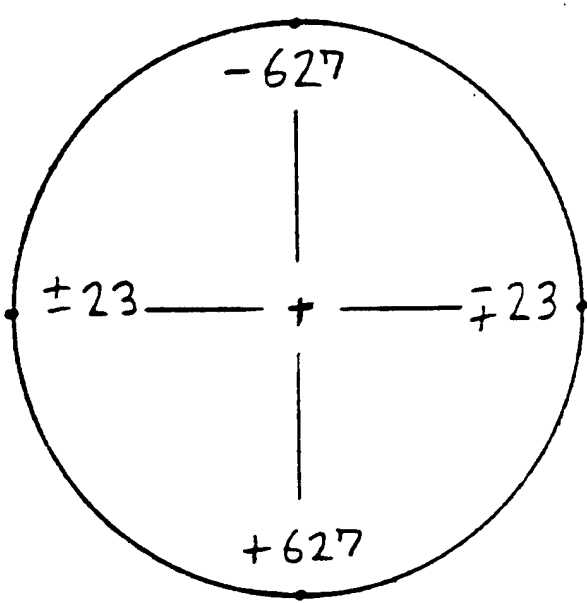

**DESIGN  
CALCULATIONS**



BY 130 DATE 10/15/93 SUBJECT FILL LINE SHEET 1 OF 5  
 CHKD DTA DATE 11/11/93 TUEF WALL JOB NO. LAB 22  
STRESS

D:\BAVE\WK\BURL-NEW\FILLTUBE.WG1

MATERIAL	TEMP DEG F	Sty PSI	Stu PSI	WORKING STRESS F/S = 3	I INCHES	OUTER DIA INCHES	PRESSURE PSI	STRESS I PSI	F/S
SAE 4130 ANNEALED	100	78000		25000	0.1875	1.5	1680	8890	12.8
	200	74800		24833				8890	13.4
	300	73800		24500				8890	13.2
	400	72500		24187				8890	13.1
	500	71000		23667				8890	12.8
	600	70000		23333				8890	12.8
	700	68800		22833				8890	12.3
	800	68000		22000				8890	11.9
	900	64000		21333				8890	11.8
	1000	69000		19667				8890	10.8
	1100	60000		18487				8890	9.0
	1200	39000		13000				8890	7.0
	1300	30000		10000				8890	5.4
	1400	22000		7333				8890	4.0
	1500	15000		5000				8890	2.7
316 SS ANNEALED	100	36900	60800	12300				5550	6.8
	200	32700	75800	10900				5550	5.9
	300	29700	74100	9900				5550	6.4
	400	28600	72500	8867				5550	4.8
	500	25100	72900	8367				5550	4.8
	600	23800	73900	7967				5550	4.3
	700	22800	72500	7800				5550	4.1
	800	22400	71800	7467				5550	4.0
	900	22000	69100	7333				5550	4.0
	1000	21700	66000	7233				5550	3.9
	1100	20800	69100	6967				5550	3.6
	1200	20800	61800	6433				5550	3.8
	1300	19400	43300	6467				5550	3.8
	1400	18300	34200	6067				5550	3.3
	1500	16300	25000	5433				5550	2.9

MATERIAL	TEMP DEG F	Sty PSI	Stu PSI	E PSI	I INCHES	OUTER DIA INCHES	PRESSURE PSI	STRESS I PSI	F/S
SAE 4130 ANNEALED	100	78000			0.1875	2	1680	8017	9.4
	200	74800						8017	9.3
	300	73500						8017	9.2
	400	72500						8017	9.0
	500	71000						8017	8.8
	600	70000						8017	8.7
	700	68800						8017	8.5
	800	68000						8017	8.2
	900	64000						8017	8.0
	1000	69000						8017	7.4
	1100	60000						8017	6.2
	1200	39000						8017	4.8
	1300	30000						8017	3.7
	1400	22000						8017	2.7
	1500	15000						8017	1.9
316 SS ANNEALED	100	36900						8017	4.8
	200	32700						8017	4.1
	300	29700						8017	3.7
	400	28600						8017	3.3
	500	25100						8017	3.1
	600	23800						8017	3.0
	700	22800						8017	2.8
	800	22400						8017	2.8
	900	22000						8017	2.7
	1000	21700						8017	2.7
	1100	20800						8017	2.6
	1200	20800						8017	2.6
	1300	19400						8017	2.4
	1400	18300						8017	2.3
	1500	16300						8017	2.0

**DESIGN  
CALCULATIONS**



BY \_\_\_\_\_ DATE \_\_\_\_\_ SUBJECT \_\_\_\_\_ SHEET 2 OF 5  
 CHK \_\_\_\_\_ DATE \_\_\_\_\_ JOB NO. \_\_\_\_\_

**STRENGTH VS TEMPERATURE  
TYPE-316 STAINLESS STEEL**

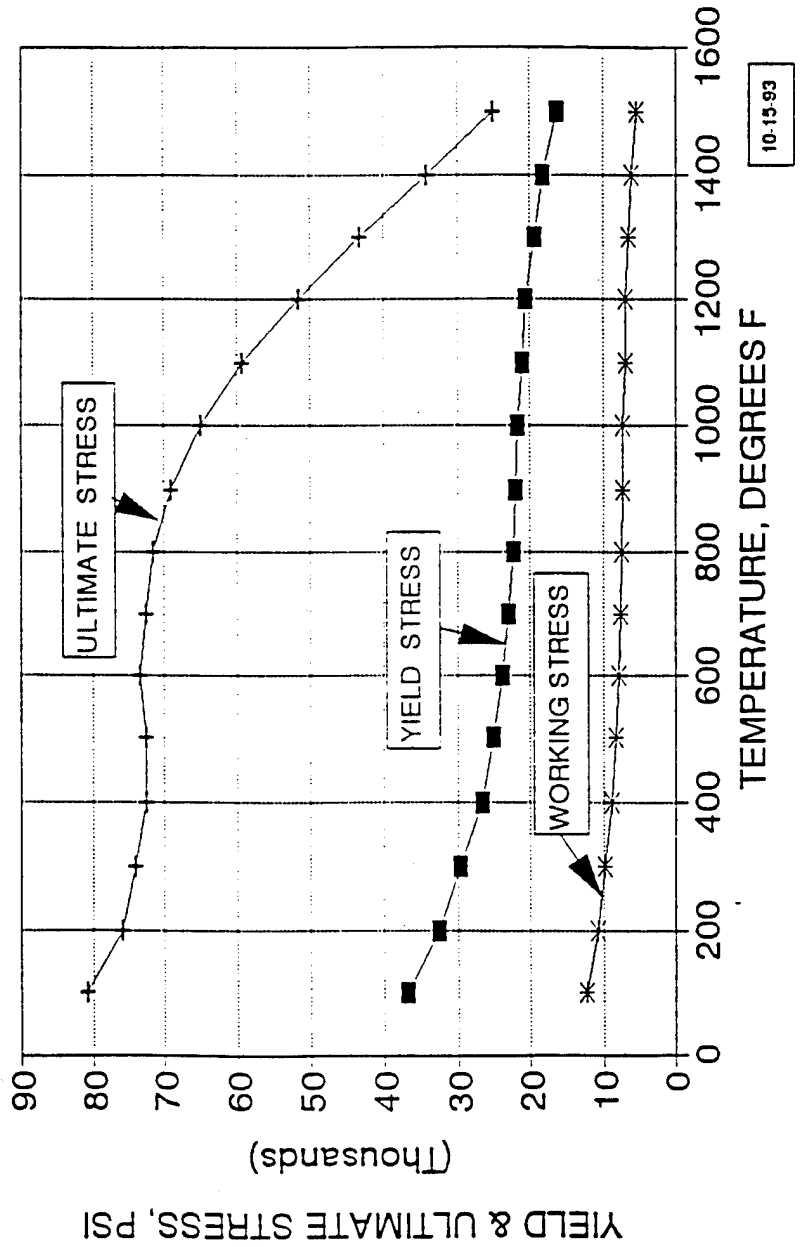

DESIGN  
CALCULATIONS



BY \_\_\_\_\_ DATE \_\_\_\_\_ SUBJECT \_\_\_\_\_ SHEET 4 OF 5  
 CHK \_\_\_\_\_ DATE \_\_\_\_\_ JOB NO. \_\_\_\_\_

**FACTOR OF SAFETY VS TEMPERATURE**  
 1.5 & 2 INCH DIA - 0.188 INCH WALL

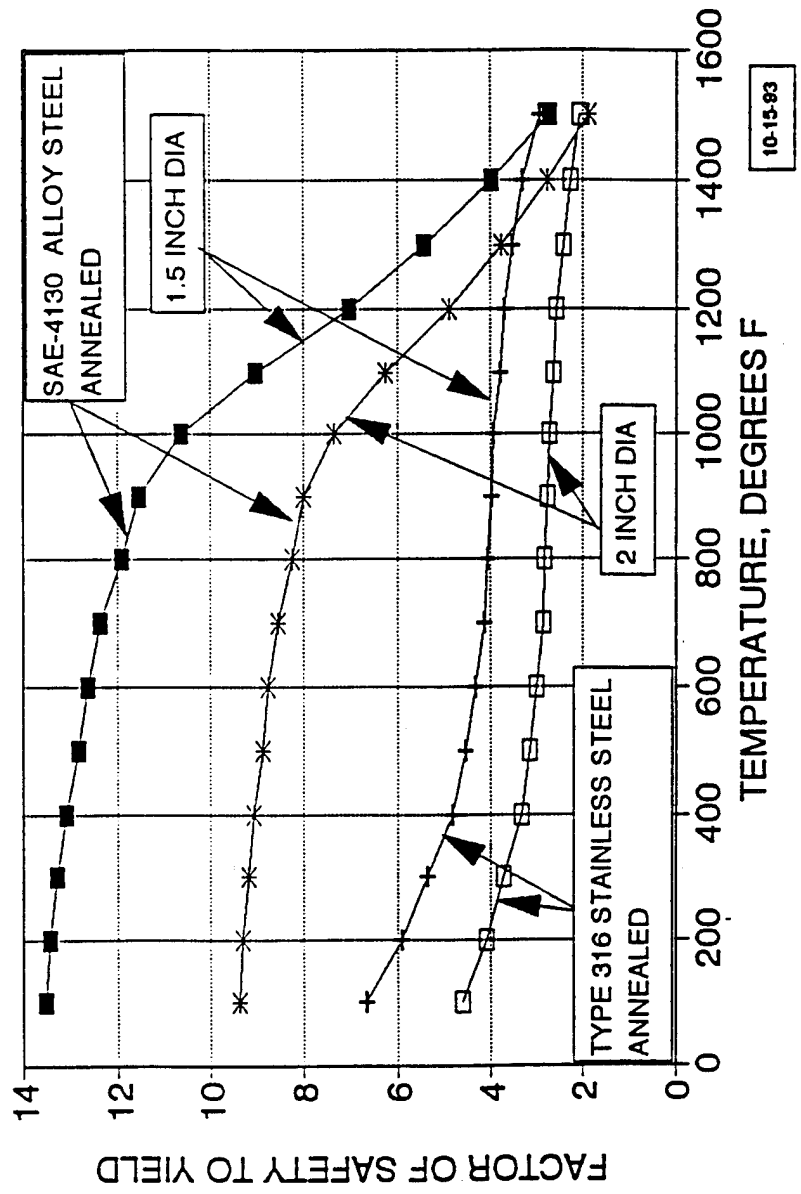

10-15-93

DESIGN  
CALCULATIONS



BY \_\_\_\_\_ DATE \_\_\_\_\_ SUBJECT \_\_\_\_\_ SHEET 5 OF 5  
CHK \_\_\_\_\_ DATE \_\_\_\_\_ JOB NO. \_\_\_\_\_

**STRESS VS TEMPERATURE**  
SAE-4130 ALLOY

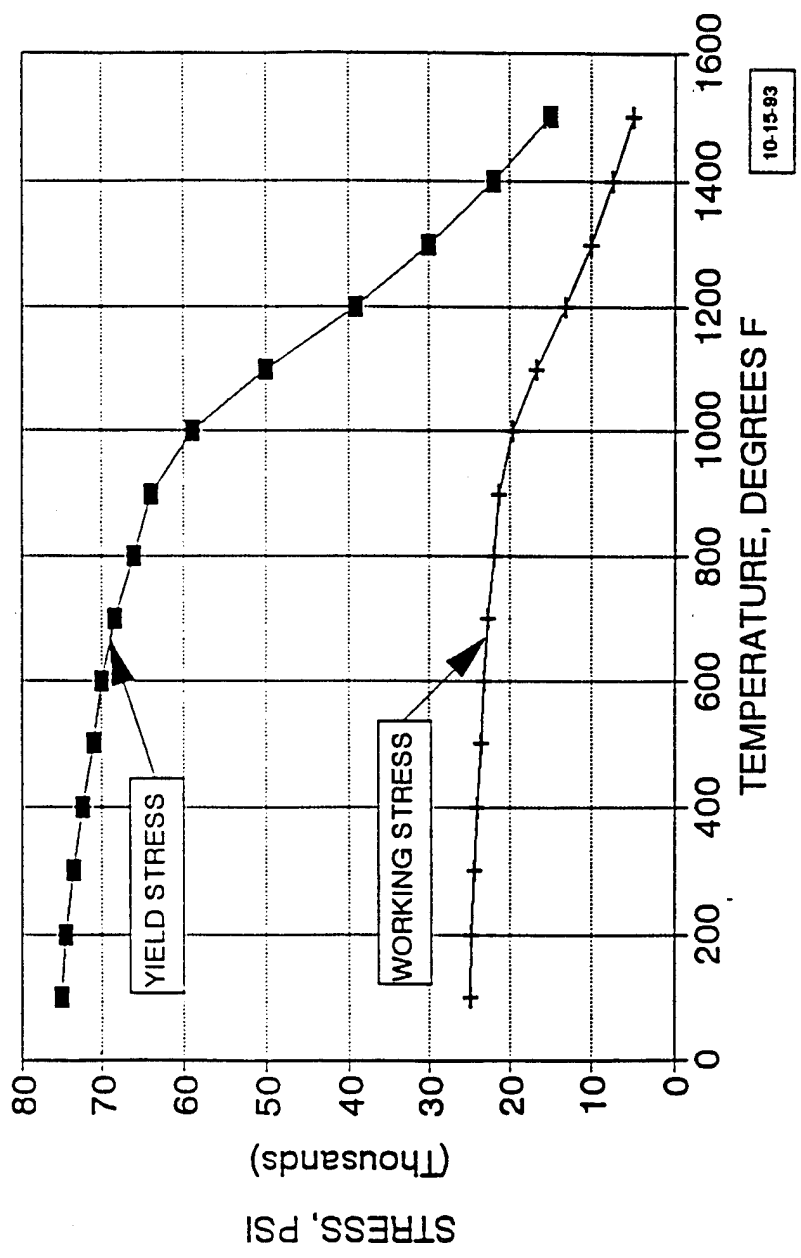

INTENTIONALLY LEFT BLANK.

## APPENDIX B HEAT TRANSFER MODELS

INTENTIONALLY LEFT BLANK.

## B.1 Heat Loss in the TVEF Driver Gas Fill Line

Heat transfer to the fill line wall was modeled in the same manner as the Pebble Bed Heater heat transfer. That is, two simultaneous ordinary differential equations are solved subject to appropriate boundary conditions. The solution is available in Reference B.1 in tabular form (Figure B.1) in terms of the nondimensional temperature

$$T_f = \frac{t_f - t_0}{t_{fi} - t_0}$$

where  $t_f$  is the fluid temperature,  $t_0$  is the ambient temperature and  $t_{fi}$  is the inlet fluid temperature.

The nondimensional distance

$$\xi = \frac{h A_w x}{\dot{m} C_{pf} L}$$

where  $h$  is the heat transfer coefficient,  $A_w$  is the pipe wall area,  $\dot{m}$  is the fluid mass flow rate and  $C_{pf}$  is the fluid specific heat.

The nondimensional time

$$\eta = \frac{h A_w t}{m_w C_{pw}}$$

where  $m_w$  is the pipe wall mass and  $C_{pw}$  is the pipe wall material specific heat.

The necessary parameters are

diameter	0.038	m
wall thickness	0.005	m
steel density	7800	kgm/m <sup>3</sup>
mass flow	1.6	kgm/sec
length	30	m

Nondimensional Time, $\tau$	Nondimensional Distance, $\xi$																			
	1	2	3	4	5	6	7	8	9	10	11	12	13	14	15	16	17	18	19	20
0	0.3679	0.1353	0.0569	0.0207	0.0075	0.0027	0.0010	0.0004	0.0001	0.0000	0.0000	0.0000	0.0000	0.0000	0.0000	0.0000	0.0000	0.0000	0.0000	0.0000
1	0.6543	0.3943	0.2248	0.1233	0.0656	0.0340	0.0173	0.0087	0.0043	0.0021	0.0010	0.0005	0.0002	0.0001	0.0000	0.0000	0.0000	0.0000	0.0000	0.0000
2	0.8174	0.6035	0.4146	0.2700	0.1685	0.1017	0.0596	0.0341	0.0191	0.0105	0.0059	0.0031	0.0016	0.0008	0.0004	0.0002	0.0001	0.0000	0.0000	0.0000
3	0.9063	0.7531	0.5833	0.4269	0.2982	0.2003	0.1302	0.0823	0.0507	0.0306	0.0174	0.0100	0.0060	0.0034	0.0019	0.0011	0.0006	0.0002	0.0001	0.0000
4	0.9529	0.8520	0.7170	0.5702	0.4339	0.3174	0.2247	0.1537	0.1026	0.0669	0.4401	0.3323	0.2432	0.1730	0.1200	0.0854	0.0616	0.0448	0.0331	0.0250
5	0.9767	0.9140	0.8150	0.6919	0.5628	0.4401	0.3323	0.2432	0.1730	0.1200	0.4441	0.3441	0.2587	0.1894	0.1350	0.0984	0.0727	0.0544	0.0418	0.0321
6	0.9887	0.9513	0.8828	0.7871	0.6747	0.5774	0.5532	0.4487	0.3537	0.2717	0.7659	0.6615	0.5497	0.4518	0.3618	0.2826	0.2143	0.1566	0.1103	0.0797
7	0.9945	0.9730	0.9278	0.8573	0.7659	0.6615	0.5532	0.4487	0.3537	0.2717	0.8363	0.7488	0.6509	0.5469	0.4544	0.3726	0.2947	0.2283	0.1712	0.1243
8	0.9974	0.9853	0.9565	0.9070	0.8385	0.7815	0.7346	0.6879	0.6469	0.6118	0.9408	0.8720	0.8185	0.7742	0.7326	0.6944	0.6603	0.6283	0.5983	0.5703
9	0.9988	0.9921	0.9744	0.9408	0.8885	0.8485	0.8074	0.7742	0.7426	0.7123	0.9631	0.9257	0.8900	0.8574	0.8266	0.7972	0.7699	0.7433	0.7182	0.6943
10	0.9994	0.9958	0.9852	0.9631	0.9257	0.8900	0.8574	0.8266	0.7972	0.7699	0.9690	0.9404	0.9118	0.8844	0.8587	0.8346	0.8119	0.7903	0.7697	0.7500
11	0.9997	0.9978	0.9989	0.9974	0.9958	0.9944	0.9926	0.9911	0.9895	0.9885	0.9879	0.9874	0.9870	0.9866	0.9862	0.9858	0.9854	0.9850	0.9846	0.9842
12	0.9999	0.9999	0.9999	0.9999	0.9999	0.9999	0.9999	0.9999	0.9999	0.9999	0.9999	0.9999	0.9999	0.9999	0.9999	0.9999	0.9999	0.9999	0.9999	0.9999
13	1.0000	1.0000	1.0000	1.0000	1.0000	1.0000	1.0000	1.0000	1.0000	1.0000	1.0000	1.0000	1.0000	1.0000	1.0000	1.0000	1.0000	1.0000	1.0000	1.0000
14	1.0000	1.0000	1.0000	1.0000	1.0000	1.0000	1.0000	1.0000	1.0000	1.0000	1.0000	1.0000	1.0000	1.0000	1.0000	1.0000	1.0000	1.0000	1.0000	1.0000
15	1.0000	1.0000	1.0000	1.0000	1.0000	1.0000	1.0000	1.0000	1.0000	1.0000	1.0000	1.0000	1.0000	1.0000	1.0000	1.0000	1.0000	1.0000	1.0000	1.0000
16	1.0000	1.0000	1.0000	1.0000	1.0000	1.0000	1.0000	1.0000	1.0000	1.0000	1.0000	1.0000	1.0000	1.0000	1.0000	1.0000	1.0000	1.0000	1.0000	1.0000
17	1.0000	1.0000	1.0000	1.0000	1.0000	1.0000	1.0000	1.0000	1.0000	1.0000	1.0000	1.0000	1.0000	1.0000	1.0000	1.0000	1.0000	1.0000	1.0000	1.0000
18	1.0000	1.0000	1.0000	1.0000	1.0000	1.0000	1.0000	1.0000	1.0000	1.0000	1.0000	1.0000	1.0000	1.0000	1.0000	1.0000	1.0000	1.0000	1.0000	1.0000
19	1.0000	1.0000	1.0000	1.0000	1.0000	1.0000	1.0000	1.0000	1.0000	1.0000	1.0000	1.0000	1.0000	1.0000	1.0000	1.0000	1.0000	1.0000	1.0000	1.0000
20	1.0000	1.0000	1.0000	1.0000	1.0000	1.0000	1.0000	1.0000	1.0000	1.0000	1.0000	1.0000	1.0000	1.0000	1.0000	1.0000	1.0000	1.0000	1.0000	1.0000
0	0.0000	0.0000	0.0000	0.0000	0.0000	0.0000	0.0000	0.0000	0.0000	0.0000	0.0000	0.0000	0.0000	0.0000	0.0000	0.0000	0.0000	0.0000	0.0000	0.0000
1	0.0010	0.0005	0.0002	0.0001	0.0000	0.0000	0.0000	0.0000	0.0000	0.0000	0.0000	0.0000	0.0000	0.0000	0.0000	0.0000	0.0000	0.0000	0.0000	0.0000
2	0.0057	0.0031	0.0016	0.0008	0.0004	0.0002	0.0001	0.0001	0.0001	0.0001	0.0001	0.0001	0.0001	0.0001	0.0001	0.0001	0.0001	0.0001	0.0001	0.0001
3	0.0181	0.0105	0.0060	0.0034	0.0019	0.0011	0.0006	0.0003	0.0002	0.0001	0.0001	0.0001	0.0001	0.0001	0.0001	0.0001	0.0001	0.0001	0.0001	0.0001
4	0.0427	0.0267	0.0165	0.0100	0.0060	0.0035	0.0020	0.0012	0.0007	0.0004	0.0002	0.0001	0.0001	0.0001	0.0001	0.0001	0.0001	0.0001	0.0001	0.0001
5	0.0814	0.0541	0.0353	0.0226	0.0143	0.0089	0.0054	0.0033	0.0020	0.0012	0.0007	0.0004	0.0002	0.0001	0.0001	0.0001	0.0001	0.0001	0.0001	0.0001
6	0.1355	0.0948	0.0650	0.0438	0.0290	0.0189	0.0122	0.0077	0.0048	0.0030	0.0023	0.0015	0.0009	0.0006	0.0004	0.0003	0.0002	0.0001	0.0001	0.0001
7	0.2037	0.1493	0.1072	0.0755	0.0523	0.0356	0.0239	0.0158	0.0103	0.0066	0.0052	0.0035	0.0022	0.0015	0.0010	0.0007	0.0005	0.0003	0.0002	0.0001
8	0.2828	0.2161	0.1617	0.1187	0.0855	0.0606	0.0422	0.0290	0.0196	0.0131	0.0096	0.0066	0.0042	0.0029	0.0020	0.0014	0.0010	0.0007	0.0005	0.0003
9	0.3686	0.2924	0.2271	0.1729	0.1292	0.0949	0.0686	0.0488	0.0342	0.0237	0.0166	0.0113	0.0077	0.0053	0.0037	0.0026	0.0019	0.0014	0.0010	0.0007
10	0.4566	0.3745	0.3009	0.2369	0.1831	0.1390	0.1038	0.0763	0.0553	0.0395	0.0282	0.0196	0.0131	0.0096	0.0066	0.0042	0.0029	0.0020	0.0014	0.0010
11	0.5424	0.4585	0.3797	0.3083	0.2458	0.1924	0.1482	0.1123	0.0838	0.0616	0.0458	0.0321	0.0220	0.0156	0.0103	0.0077	0.0053	0.0037	0.0026	0.0019
12	0.6228	0.5406	0.4602	0.3843	0.3151	0.2538	0.2010	0.1566	0.1202	0.0909	0.0686	0.0500	0.0361	0.0253	0.0177	0.0122	0.0087	0.0061	0.0043	0.0031
13	0.6953	0.6179	0.5391	0.4617	0.3884	0.3211	0.2611	0.2089	0.1646	0.1278	0.0984	0.0742	0.0544	0.0395	0.0282	0.0196	0.0131	0.0096	0.0066	0.0042
14	0.7585	0.6882	0.6136	0.5376	0.4630	0.3921	0.3266	0.2679	0.2162	0.1720	0.1350	0.1026	0.0754	0.0544	0.0395	0.0282	0.0196	0.0131	0.0096	0.0066
15	0.8121	0.7501	0.6819	0.6097	0.5364	0.4642	0.3954	0.3316	0.2739	0.2230	0.1730	0.1302	0.0984	0.0727	0.0544	0.0395	0.0282	0.0196	0.0131	0.0096
16	0.8563	0.8032	0.7425	0.6761	0.6062	0.5352	0.4653	0.3985	0.3362	0.2796	0.2200	0.1730	0.1302	0.0984	0.0727	0.0544	0.0395	0.0282	0.0196	0.0131
17	0.8919	0.8475	0.7950	0.7355	0.6708	0.6030	0.5342	0.4663	0.4013	0.3403	0.2826	0.2283	0.1772	0.1350	0.0984	0.0727	0.0544	0.0395	0.0282	0.0196
18	0.9199	0.8837	0.8393	0.7874	0.7291	0.6660	0.6001	0.5332	0.4672	0.4039	0.3441	0.2887	0.2372	0.1894	0.1441	0.1026	0.0754	0.0544	0.0395	0.0282
19	0.9415	0.9126	0.8760	0.8317	0.7804	0.7232	0.6616	0.5974	0.5323	0.4681	0.4077	0.3500	0.2966	0.2466	0.1994	0.1544	0.1118	0.0844	0.0616	0.0448
20	0.9579	0.9353	0.9056	0.8686	0.8245	0.7738	0.7177	0.6575	0.5949	0.5315	0.4700	0.4111	0.3544	0.2999	0.2499	0.2022	0.1566	0.1131	0.0854	0.0616

Figure B.1 Nondimensional Fluid Temperature

$C_{pf}$	1050	J/kgm/K
$C_{pw}$	460	J/kgm/K
$T_i$	650	K

The calculated nondimensional distance at the driver inlet (where we care the most about the gas temperature) is  $\xi = 6.5$ . Figure B.2 plotted from Figure B.1 was helpful in interpolating values of  $T_f$ .

## B.2 Heat Loss in the TVEF Driver

The driver gas temperature is time dependent because the driver is being pressurized (compression heating), because thermal energy is lost to the driver wall and because driver gas is selectively vented.

### Thermodynamic Model

The driver tube is an open thermodynamic system with mass entering and leaving thereby adding and subtracting enthalpy. The driver walls are rigid so no work is done by the system but thermal energy is lost to the walls by heat transfer. The time dependent thermal energy in the system is

$$\dot{E} = \dot{m}_i h_i - \dot{m}_v h_v - \dot{Q}$$

where  $m$  is the driver gas mass,  $h$  is specific enthalpy,  $Q$  is thermal energy transferred to the wall, the subscripts  $i$  and  $v$  denote flow into and vented out of the driver respectively and the dot symbol indicates a time derivative.

The thermal energy in the system at any time  $t$  is

$$E = m C_v T$$

where  $C_v$  is the gas specific heat at constant volume. The enthalpy

$$H = m C_p T$$

where  $C_p$  is the gas specific heat at constant pressure. By integrating the mass and enthalpy entering and leaving the system over time and averaging over the instantaneous mass in the system

# GRAPHICAL INTERPOLATION

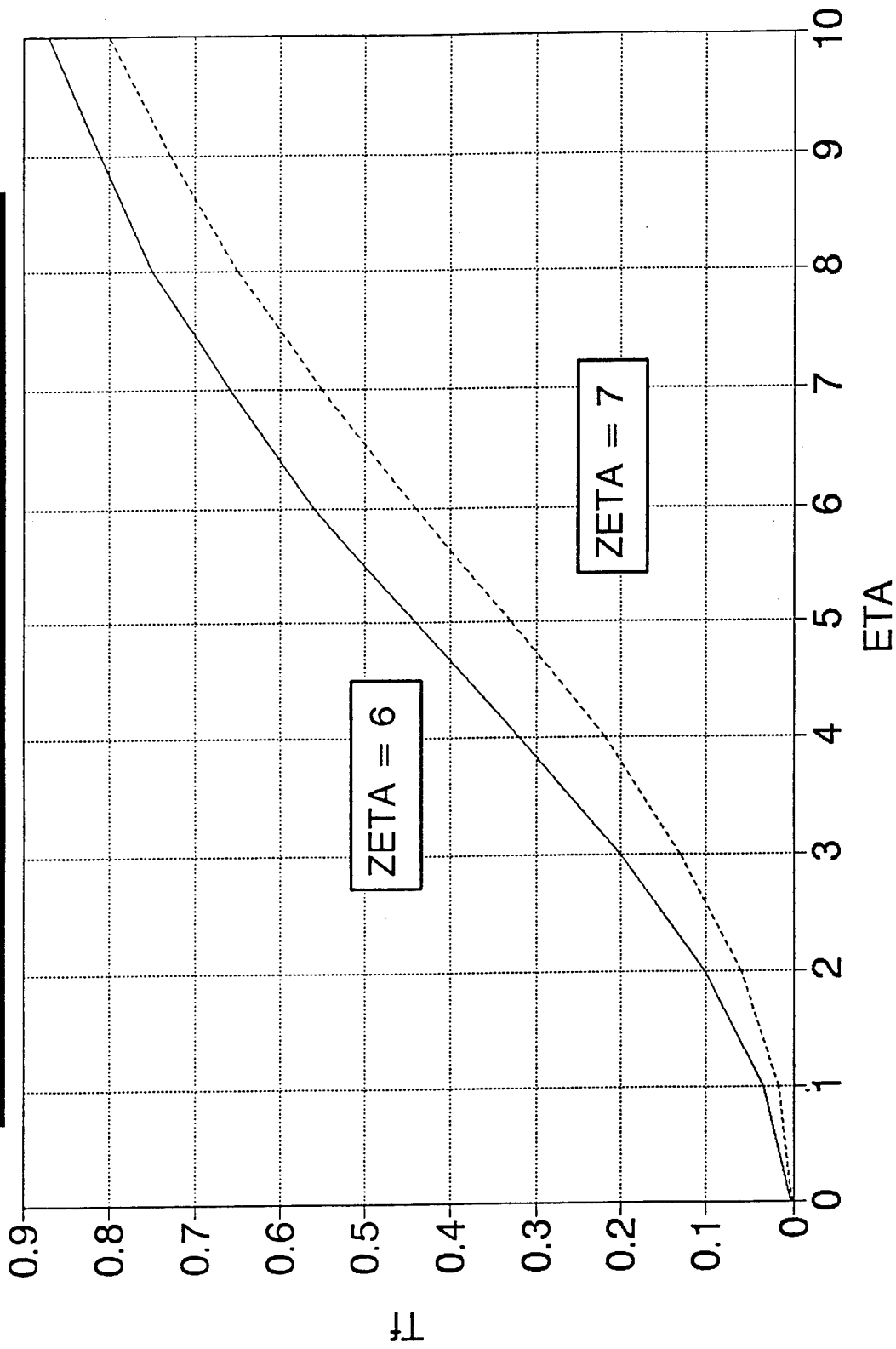

Figure B.2 Graphical Interpolation of Figure B.1

$$T = m^{-1} [ m_0 T_0 + \int_0^t [ \gamma ( \dot{m}_i T_i - \dot{m}_v T_v ) - C_V^{-1} \dot{Q} ] dt ]$$

where  $\gamma$  is the ratio of specific heats and

$$m = m_0 + \int_0^t ( \dot{m}_i - \dot{m}_v ) dt$$

The driver gas pressure is obtained from the perfect gas law.

For choked flow venting through a constant area port the mass flow rate out

$$\dot{m}_v = C_1 A_T \frac{P}{\sqrt{T}}$$

where

$$C_1 = \left[ \frac{\gamma}{R} \left( \frac{2}{\gamma + 1} \right)^{\frac{\gamma + 1}{\gamma - 1}} \right]^{\frac{1}{2}}$$

and R is the gas constant.

To account for temperature effects on the gas properties, the nitrogen gas viscosity and conductivity were approximated by

$$\mu = \mu_a \left( \frac{T}{T_a} \right)^{0.75}$$

and

$$k = k_a [ 1 + 0.0024 ( T - 300 ) ]$$

### Heat Transfer Model

Heat transfer to the wall is dominated by free convection; complex circulatory flow fields driven by buoyancy provide a mechanism for establishing a thermal boundary layer next to the wall. In this work a steady state empirical

correlation of the form

$$Nus = A Ra^B$$

is used where Nus is the nondimensional Nussult number, Ra is the nondimensional Rayleigh number and the geometry dependent coefficients A and B are historically determined from test data (or more recently numerical solutions of the Navier Stokes equations). Using the steady state correlation implies that the driver flowfield adjusts to the changing driver gas thermal conditions within the time step used in the analysis.

The Rayleigh number is the ratio of the gas buoyancy forces to viscous forces

$$Ra = \frac{\Delta \rho}{\rho} \frac{g D^3}{\nu^2} Pr$$

where g is the acceleration of gravity,  $\rho$  is the average gas density,  $\Delta \rho$  is the gas density gradient at the wall, D is the driver diameter,  $\nu$  is kinematic viscosity and Pr is the Prandtl number.

The maximum Rayleigh number occurs at the peak driver gas conditions for which the normalized density gradient is about 1 and the kinematic viscosity is about 5.E-7 giving a Rayleigh number of 1.E12. This is two orders of magnitude beyond the range of any substantiated heat transfer data.

The nondimensional Nussult number is

$$Nus = \frac{h_c D}{k}$$

where  $h_c$  is a film coefficient and k is the thermal conductivity of the gas.

Finally, the heat transfer rate to the wall is

$$\dot{Q} = h_c A_w (T - T_w)$$

where  $A_w$  is the driver wall area and T is the average driver gas temperature.

No heat transfer correlations are available for the geometry and flow conditions of interest (Reference B.2). In order to make engineering predictions for the driver filling strategies, it was assumed that the driver cross section is square and free convection heat transfer correlations were examined for free standing walls and upward and downward facing flat plates (Reference B.3). These were averaged to obtain the correlation

$$Nus = 0.1 Ra^{0.33}$$

This approach will be less accurate as time progresses and the flow in the driver stratifies. However, the driver gas cannot be allowed to cool substantially so the approach should provide reasonable estimates for the allowable deviations from design conditions.

### **Model Validation**

Prior to recent driver filling experiments conducted by ARL in the 1/6th Scale Test Bed, suitable test data simply did not exist to validate the heated driver gas filling model. Early test data from the shakedown test were generously made available by ARL without editing or caveating for comparison with the driver filling model; subsequent ARL tests will benefit from improved test procedures so the present comparison should not be viewed as the final word.

The 1/6th Scale Test Bed driver was instrumented with 3 thermocouples distributed along the top of the driver, 3 thermocouples along the bottom of the driver, a rake of 15 thermocouples near the center of the tube, one thermocouple at the gas inlet and one pressure gauge; the liquid nitrogen supply rate to the PBH was measured with a turbine flowmeter.

Heated gas was supplied to the driver by the PBH at a variable rate starting with 0.25 kgm/sec (5 GPM) at 200 seconds, increasing to 1 kgm/sec (20 GPM) at 325 seconds, increasing to 1.35 kgm/sec (27 GPM) at 690 seconds and ceasing at 850 seconds. An 0.025 m (1 inch) diameter vent valve was initially open and was closed at 500 seconds. After making certain adjustments to the test data (reducing the mass flow rate by 15 percent and delaying the rake temperature record start up time by 150 sec.), a model calculation using the test parameters was compared to the measured gas

temperature (Figure B.3).

Model calculations provide a mass averaged temperature. A simple average of the 3 upper and 3 lower thermocouple measurements did not agree well with the calculation. On the other hand, temperature measurements from a thermocouple located on the rake centerline agreed very well with the model calculations including a rapid rise to peak temperature. It was subsequently learned that the rake thermocouples have a much faster response time (10 msec compared with 6 and 11 sec) than the 6 thermocouples; however, it is difficult to imagine that difference accounting for discrepancies at times on the order of 100s of seconds into the fill cycle. It is important to note that once the gas supply is shut off, the model does an excellent job of calculating the driver gas cooling. The temperature record from the rake centerline is chosen as representative.

## References

B.1 Schmidt, F. and Willmott, A., **Thermal Energy Storage and Regeneration**, Hemisphere Publishing Corporation, 1981.

B.2 Hove, D. and Osofsky, I., **An Analytical Design Model for the BRL Heated Driver Gas Supply System**, Twelfth International Symposium on Military Applications of Blast Simulation, September 1991.

B.3 Personal Communication, Sadik Kakic, Editor, **Handbook of Single Phase Convective Heat Transfer**, Wiley Interscience, 1987.

B.4 Holman, J., **Heat Transfer**, Fourth Edition, McGraw-Hill Book Company

# 1/6TH SCALE DRIVER FILLING

RAW TEST DATA ADJUSTED

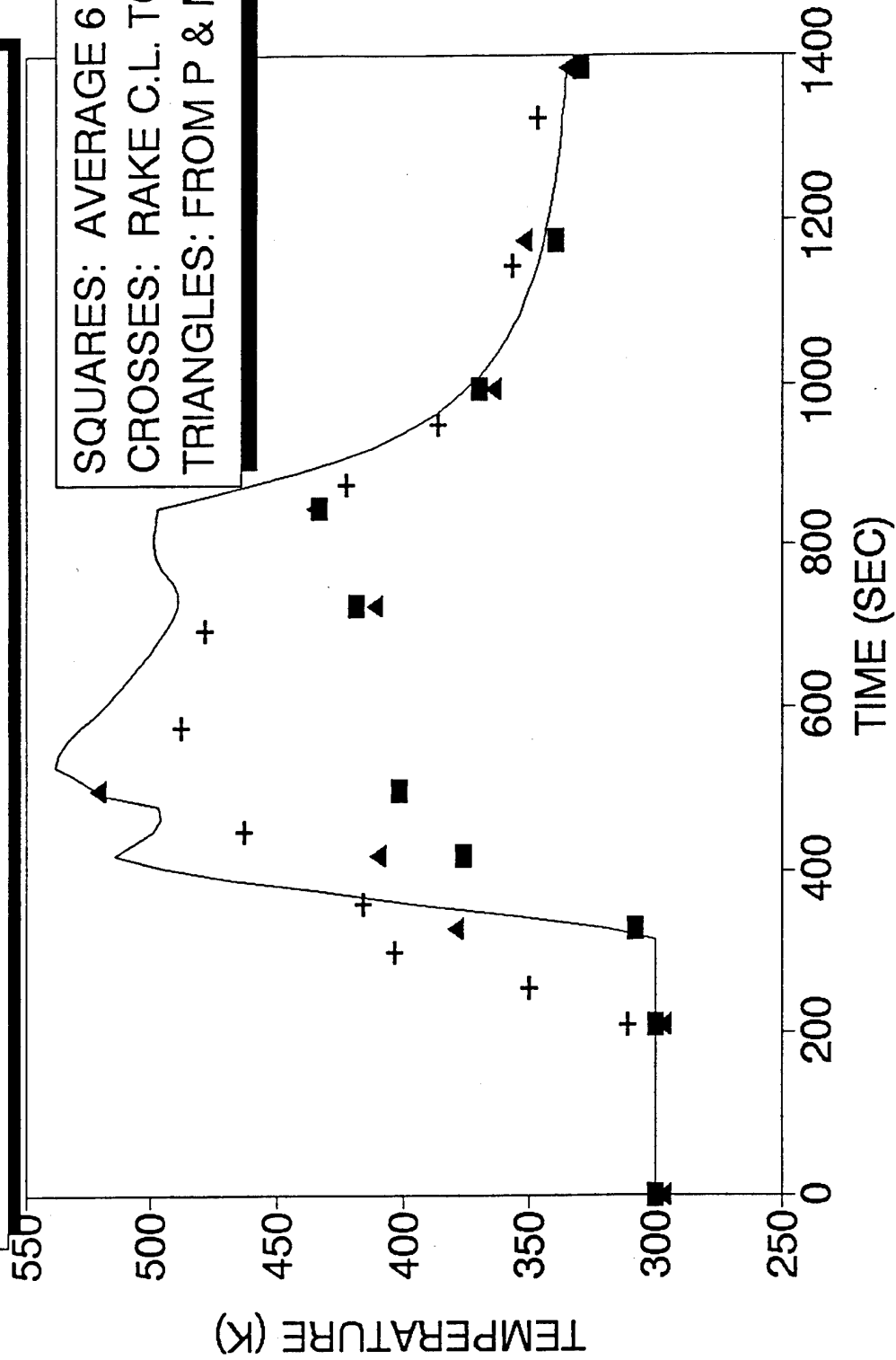

10/14/93

Figure B.3 Comparison of Model with Early Test Results

## ADDENDUM TO APPENDIX B

The simultaneous first order differential equations governing the heat transfer in the fill pipe are:

$$\frac{dT_f}{d\xi} = T_m - T_f \quad \frac{dT_m}{d\eta} = T_f - T_m$$

where  $T_m$  is the pipe material (wall) temperature. The boundary conditions are:

$$\xi = 0 \quad T_f = 1 \quad T_m = 1 - e^{-\eta}$$

$$\eta = 0 \quad T_m = 0$$

These equations can be evaluated at any distance  $x$  along a pipe of length  $L$ . Of most interest is the end of the pipe where  $x/L = 1$ . For the present TVEF peak driver fill conditions, the heat transfer coefficient  $h = 4004$  Watts/m<sup>2</sup>/°K.

NO. OF  
COPIES      ORGANIZATION

2      ADMINISTRATOR  
ATTN DTIC DDA  
DEFENSE TECHNICAL INFO CTR  
CAMERON STATION  
ALEXANDRIA VA 22304-6145

1      DIRECTOR  
ATTN AMSRL OP SD TA  
US ARMY RESEARCH LAB  
2800 POWDER MILL RD  
ADELPHI MD 20783-1145

3      DIRECTOR  
ATTN AMSRL OP SD TL  
US ARMY RESEARCH LAB  
2800 POWDER MILL RD  
ADELPHI MD 20783-1145

1      DIRECTOR  
ATTN AMSRL OP SD TP  
US ARMY RESEARCH LAB  
2800 POWDER MILL RD  
ADELPHI MD 20783-1145

ABERDEEN PROVING GROUND

5      DIR USARL  
ATTN AMSRL OP AP L (305)

<u>NO. OF COPIES</u>	<u>ORGANIZATION</u>	<u>NO. OF COPIES</u>	<u>ORGANIZATION</u>
2	HQDA ATTN SARD TR MS K KOMINOS DR R CHAIT WASHINGTON DC 20310-0103	1	CHAIRMAN JOINT CHIEFS OF STAFF ATTN J5 R&D DIVISION WASHINGTON DC 20301
2	HQDA ATTN SARD TT MS C NASH DR F MILTON WASHINGTON DC 20310-0103	2	DA DCSOPS ATTN TECHNICAL LIBRARY DIR OF CHEM & NUC OPS WASHINGTON DC 20310
2	DIRECTOR FEDERAL EMERGENCY MNGMNT AGENCY ATTN PUBLIC RELATIONS OFFICE TECHNICAL LIBRARY WASHINGTON DC 20472	3	COMMANDER FIELD COMMAND DNA ATTN FCPR FCTMOF NMHE KIRTLAND AFB NM 87115
1	CHAIRMAN DOD EXPLOSIVES SAFETY BOARD ROOM 856 C HOFFMAN BLDG 1 2461 EISENHOWER AVENUE ALEXANDRIA VA 22331-0600	1	U S ARMY RESEARCH DEVELOPMENT AND STANDARDIZATION GROUP UK ATTN DR ROY E REICHENBACH PSC 802 BOX 15 FPO AE 09499-1500
1	DIRECTOR OF DEFENSE RESEARCH AND ENGINEERING ATTN DD TWP WASHINGTON DC 20301	10	CENTRAL INTELLIGENCE AGENCY DIR DB STANDARD ATTN GE 47 HQ WASHINGTON DC 20505
1	DIRECTOR DEFENSE INTELLIGENCE AGENCY ATTN DT 2 WPNS & SYS DIVISION WASHINGTON DC 20301	1	DIRECTOR ADVANCED RESEARCH PROJECTS AGENCY ATTN TECHNICAL LIBRARY 3701 NORTH FAIRFAX DRIVE ARLINGTON VA 22203-1714
1	ASSISTANT SECRETARY OF DEFENSE ATOMIC ENERGY ATTN DOCUMENT CONTROL WASHINGTON DC 20301	2	COMMANDER US ARMY NRDEC ATTN AMSNA D DR D SIELING STRNC UE J CALLIGEROS NATICK MA 01762
9	DIRECTOR DEFENSE NUCLEAR AGENCY ATTN CSTI TECHNICAL LIBRARY DDIR DFSP NANS OPNA SPSD SPTD DFTD TDTR WASHINGTON DC 20305	2	COMMANDER US ARMY CECOM ATTN AMSEL RD AMSEL RO TPPO P FT MONMOUTH NJ 07703-5301
		1	COMMANDER US ARMY CECOM R&D TECHNICAL LIBRARY ATTN ASQNC ELC IS L R MYER CTR FT MONMOUTH NJ 07703-5000

<u>NO. OF COPIES</u>	<u>ORGANIZATION</u>	<u>NO. OF COPIES</u>	<u>ORGANIZATION</u>
1	MIT ATTN TECHNICAL LIBRARY CAMBRIDGE MA 02139	3	COMMANDER US ARMY NUCLEAR & CHEMICAL AGENCY 7150 HELLER LOOP SUITE 101 SPRINGFIELD VA 22150-3198
1	COMMANDER US ARMY NGIC ATTN RESEARCH & DATA BRANCH 220 7TH STREET NE CHARLOTTESVILLE VA 22901-5396	1	COMMANDER US ARMY CORPS OF ENGINEERS FT WORTH DISTRICT ATTN CESWF PM J PO BOX 17300 FT WORTH TEXAS 76102-0300
1	COMMANDER US ARMY ARDEC ATTN SMCAR FSM W BARBER BLDG 94 PICATINNY ARSENAL NJ 07806-5000	1	DIRECTOR TRAC FLVN ATTN ATRC FT LEAVENWORTH KS 66027-5200
1	DIRECTOR US ARMY TRAC FT LEE ATTN ATRC L MR CAMERON FT LEE VA 23801-6140	1	COMMANDER US ARMY RESEARCH OFFICE ATTN SLCRO D PO BOX 12211 RESEARCH TRIANGLE PARK NC 27709-2211
1	US ARMY MISSILE & SPACE INTELLIGENCE CENTER ATTN AIAMS YDL REDSTONE ARSENAL AL 35898-5500	1	COMMANDER NAVAL ELECTRONIC SYSTEMS COMMAND ATTN PME 117 21A WASHINGTON DC 20360
1	COMMANDING OFFICER CODE L51 NAVAL CIVIL ENGINEERING LABORATORY ATTN J TANCRETO PORT HUENEME CA 93043-5003	1	DIRECTOR HQ TRAC RPD ATTN ATRC RPR RADDA FT MONROE VA 23651-5143
2	COMMANDER US ARMY STRATEGIC DEFENSE COMMAND ATTN CSSD H MPL TECH LIB CSSD H XM DR DAVIES PO BOX 1500 HUNTSVILLE AL 35807	2	OFFICE OF NAVAL RESEARCH ATTN DR A FAULSTICK CODE 23 800 N QUINCY STREET ARLINGTON VA 22217
3	COMMANDER US ARMY CORPS OF ENGINEERS WATERWAYS EXPERIMENT STATION ATTN CEWES SS R J WATT CEWES SE R J INGRAM CEWES TL TECH LIBRARY PO BOX 631 VICKSBURG MS 39180-0631	1	DIRECTOR TRAC WSMR ATTN ATRC WC KIRBY WSMR NM 88002-5502
1	COMMANDER US ARMY ENGINEER DIVISION ATTN HNDED FD PO BOX 1500 HUNTSVILLE AL 35807	1	COMMANDER NAVAL SEA SYSTEMS COMMAND ATTN CODE SEA 62R DEPARTMENT OF THE NAVY WASHINGTON DC 20362-5101

<u>NO. OF</u> <u>COPIES</u>	<u>ORGANIZATION</u>	<u>NO. OF</u> <u>COPIES</u>	<u>ORGANIZATION</u>
1	COMMANDER US ARMY WSMR ATTN STEWS NED DR MEASON WSMR NM 88002-5158	1	COMMANDER NAVAL WEAPONS EVALUATION FAC ATTN DOCUMENT CONTROL KIRTLAND AFB NM 87117
2	CHIEF OF NAVAL OPERATIONS DEPARTMENT OF THE NAVY ATTN OP 03EG OP 985F WASHINGTON DC 20350	1	RADC EMTLD DOCUMENT LIBRARY GRIFFISS AFB NY 13441
1	COMMANDER DAVID TAYLOR RESEARCH CENTER ATTN CODE 522 TECH INFO CTR BETHESDA MD 20084-5000	1	AEDC ATTN R MCAMIS MAIL STOP 980 ARNOLD AFB TN 37389
1	OFFICER IN CHARGE CODE L31 CIVIL ENGINEERING LABORATORY NAVAL CONSTRUCTION BATTALION CTR ATTN TECHNICAL LIBRARY PORT HUENEME CA 93041	1	AFESC RDCS ATTN PAUL ROSENGREN TYNDALL AFB FL 32403
1	COMMANDING OFFICER WHITE OAK WARFARE CENTER ATTN CODE WA501 NNPO SILVER SPRING MD 20902-5000	1	OLAC PL TSTL ATTN D SHIPLETT EDWARDS AFB CA 93523-5000
1	COMMANDER CODE 533 NAVAL WEAPONS CENTER ATTN TECHNICAL LIBRARY CHINA LAKE CA 93555-6001	1	AFIT ENY ATTN LTC HASEN PHD WRIGHT PATTERSON AFB OH 45433-6583
1	COMMANDER DAHLGREN DIVISION NAVAL SURFACE WARFARE CENTER ATTN CODE E23 LIBRARY DAHLGREN VA 22448-5000	2	AIR FORCE ARMAMENT LABORATORY ATTN AFATL DOIL AFATL DLYV EGLIN AFB FL 32542-5000
1	COMMANDER NAVAL RESEARCH LABORATORY ATTN CODE 2027 TECHNICAL LIBRARY WASHINGTON DC 20375	1	DIRECTOR IDAHO NATIONAL ENGINEERING LAB ATTN SPEC PROGRAMS J PATTON 2151 NORTH BLVD MS 2802 IDAHO FALLS ID 83415
1	OFFICER IN CHARGE WHITE OAK WARFARE CTR DETACHMENT ATTN CODE E232 TECHNICAL LIBRARY 10901 NEW HAMPSHIRE AVENUE SILVER SPRING MD 20903-5000	3	PHILLIPS LABORATORY AFWL ATTN NTE NTED NTES KIRTLAND AFB NM 87117-6008
1	AL LSCF ATTN J LEVINE EDWARDS AFB CA 93523-5000	1	DIRECTOR LAWRENCE LIVERMORE NATIONAL LAB ATTN TECH INFO DEPT L 3 PO BOX 808 LIVERMORE CA 94550
		1	AFIT ATTN TECHNICAL LIBRARY BLDG 640 B WRIGHT PATTERSON AFB OH 45433

<u>NO. OF COPIES</u>	<u>ORGANIZATION</u>
1	DIRECTOR NATIONAL AERONAUTICS & SPACE ADMIN ATTN SCIENTIFIC & TECH INFO FAC PO BOX 8757 BWI AIRPORT BALTIMORE MD 21240
1	FTD NIIS WRIGHT PATTERSON AFB OH 45433
3	KAMAN SCIENCES CORPORATION ATTN LIBRARY PA ELLIS FH SHELTON PO BOX 7463 COLORADO SPRINGS CO 80933-7463
4	DIRECTOR IDAHO NATIONAL ENGINEERING LAB EG&G IDAHO INC ATTN R GUENZLER MS 3505 R HOLMAN MS 3510 R A BERRY W C REED PO BOX 1625 IDAHO FALLS ID 83415
5	DIRECTOR SANDIA NATIONAL LABS ATTN DOC CONTROL 3141 C CAMERON DIV 6215 A CHABAI DIV 7112 D GARDNER DIV 1421 J MCGLAUN DIV 1541 PO BOX 5800 ALBUQUERQUE NM 87185-5800
2	DIRECTOR LOS ALAMOS NATIONAL LABORATORY ATTN TH DOWLER MS F602 DOC CONTROL FOR REPORTS LIBRARY PO BOX 1663 LOS ALAMOS NM 87545
1	BLACK & VEATCH ENGINEERS ARCHITECTS ATTN HD LAVERENTZ 1500 MEADOW LAKE PARKWAY KANSAS CITY MO 64114

<u>NO. OF COPIES</u>	<u>ORGANIZATION</u>
1	DIRECTOR SANDIA NATIONAL LABORATORIES LIVERMORE LABORATORY ATTN DOC CONTROL FOR TECH LIB PO BOX 969 LIVERMORE CA 94550
1	DIRECTOR NASA AMES RESEARCH CENTER APPLIED COMPUTATIONAL AERO BRANCH ATTN DR T HOLTZ MS 202 14 MOFFETT FIELD CA 94035
1	DIRECTOR NASA LANGLEY RESEARCH CENTER ATTN TECHNICAL LIBRARY HAMPTON VA 23665
2	APPLIED RESEARCH ASSOCIATES INC ATTN J KEEFER NH ETHRIDGE PO BOX 548 ABERDEEN MD 21001
1	ADA TECHNOLOGIES INC ATTN JAMES R BUTZ HONEYWELL CENTER SUITE 110 304 INVERNESS WAY SOUTH ENGLEWOOD CO 80112
1	ALLIANT TECHSYSTEMS INC ATTN ROGER A RAUSCH MN48 3700 7225 NORTHLAND DRIVE BROOKLYN PARK MN 55428
1	CARPENTER RESEARCH CORPORATION ATTN H JERRY CARPENTER 27520 HAWTHORNE BLVD SUITE 263 PO BOX 2490 ROLLING HILLS ESTATES CA 90274
1	AEROSPACE CORPORATION ATTN TECH INFO SERVICES PO BOX 92957 LOS ANGELES CA 90009
1	GOODYEAR CORPORATION ATTN RM BROWN BLDG 1 SHELTER ENGINEERING LITCHFIELD PARK AZ 85340

<u>NO. OF COPIES</u>	<u>ORGANIZATION</u>
1	THE BOEING COMPANY ATTN AEROSPACE LIBRARY PO BOX 3707 SEATTLE WA 98124
2	FMC CORPORATION ADVANCED SYSTEMS CENTER ATTN J DROTLEFF C KREBS MDP 95 BOX 58123 2890 DE LA CRUZ BLVD SANTA CLARA CA 95052
1	CALIFORNIA RES & TECH INC ATTN M ROSENBLATT 20943 DEVONSHIRE STREET CHATSWORTH CA 91311
1	SVERDRUP TECHNOLOGY INC SVERDRUP CORPORATION AEDC ATTN BD HEIKKINEN MS 900 ARNOLD AFB TN 37389-9998
2	DYNAMICS TECHNOLOGY INC ATTN D T HOVE G P MASON 21311 HAWTHORNE BLVD SUITE 300 TORRANCE CA 90503
1	KTECH CORPORATION ATTN DR E GAFFNEY 901 PENNSYLVANIA AVE NE ALBUQUERQUE NM 87111
1	EATON CORPORATION DEFENSE VALVE & ACTUATOR DIV ATTN J WADA 2338 ALASKA AVE EL SEGUNDO CA 90245-4896
2	MCDONNELL DOUGLAS ASTRONAUTICS CORP ATTN ROBERT W HALPRIN KA HEINLY 5301 BOLSA AVENUE HUNTINGTON BEACH CA 92647

<u>NO. OF COPIES</u>	<u>ORGANIZATION</u>
4	KAMAN AVIDYNE ATTN R RUETENIK 2 CP S CRISCIONE R MILLIGAN 83 SECOND AVENUE NORTHWEST INDUSTRIAL PARK BURLINGTON MA 01830
1	MDA ENGINEERING INC ATTN DR DALE ANDERSON 500 EAST BORDER STREET SUITE 401 ARLINGTON TX 07601
2	PHYSICS INTERNATIONAL CORPORATION PO BOX 5010 SAN LEANDRO CA 94577-0599
2	KAMAN SCIENCES CORPORATION ATTN DASIAC PO DRAWER 1479 816 STATE STREET SANTA BARBARA CA 93102-1479
1	R&D ASSOCIATES ATTN GP GANONG PO BOX 9377 ALBUQUERQUE NM 87119
1	LOCKHEED MISSILES & SPACE CO ATTN J J MURPHY DEPT 81 11 BLDG 154 PO BOX 504 SUNNYVALE CA 94086
2	SCIENCE CENTER ROCKWELL INTERNATIONAL CORP ATTN DR S CHAKRAVARTHY DR D OTA 1049 CAMINO DOS RIOS THOUSAND OAKS CA 91358
1	ORLANDO TECHNOLOGY INC ATTN D MATUSKA 60 SECOND STREET BLDG 5 SHALIMAR FL 32579

<u>NO. OF COPIES</u>	<u>ORGANIZATION</u>
3	S CUBED A DIVISION OF MAXWELL LABS INC ATTN TECHNICAL LIBRARY R DUFF K PYATT PO BOX 1620 LA JOLLA CA 92037-1620
2	THE RALPH M PARSONS COMPANY ATTN T M JACKSON LB TS PROJECT MANAGER 100 WEST WALNUT STREET PASADENA CA 91124
1	SAIC ATTN J GUEST 2301 YALE BLVD SE SUITE E ALBUQUERQUE NM 87106
1	SUNBURST RECOVERY INC ATTN DR C YOUNG PO BOX 2129 STEAMBOAT SPRINGS CO 80477
1	SAIC ATTN N SINHA 501 OFFICE CENTER DRIVE APT 420 FT WASHINGTON PA 19034-3211
1	SVERDRUP TECHNOLOGY INC ATTN RF STARR PO BOX 884 TULLAHOMA TN 37388
2	S CUBED A DIVISION OF MAXWELL LABS INC ATTN C E NEEDHAM L KENNEDY 2501 YALE BLVD SE ALBUQUERQUE NM 87106
3	SRI INTERNATIONAL ATTN DR GR ABRAHAMSON DR J GRAN DR B HOLMES 333 RAVENWOOD AVENUE MENLO PARK CA 94025

<u>NO. OF COPIES</u>	<u>ORGANIZATION</u>
1	TRW BALLISTIC MISSILE DIVISION ATTN H KORMAN MAIL STATION 526 614 PO BOX 1310 SAN BERNADINO CA 92402
1	BATTELLE TWSTIAC 505 KING AVENUE COLUMBUS OH 43201-2693
1	THERMAL SCIENCE INC ATTN R FELDMAN 2200 CASSENS DRIVE ST LOUIS MO 63026
2	DENVER RESEARCH INSTITUTE ATTN J WISOTSKI TECHNICAL LIBRARY PO BOX 10758 DENVER CO 80210
1	STATE UNIVERSITY OF NEW YORK MECHANICAL & AEROSPACE ENGINEERING ATTN DR PEYMAN GIVI BUFFALO NY 14260
2	UNIVERSITY OF MARYLAND INSTITUTE FOR ADV COMPUTER STUDIES ATTN L DAVIS G SOBIESKI COLLEGE PARK MD 20742
2	THINKING MACHINES CORPORATION ATTN G SABOT R FERREL 245 FIRST STREET CAMBRIDGE MA 02142-1264
1	NORTHROP UNIVERSITY ATTN DR FB SAFFORD 5800 W ARBOR VITAE STREET LOS ANGELES CA 90045
1	CALIFORNIA INSTITUTE OF TECHNOLOGY ATTN T J AHRENS 1201 E CALIFORNIA BLVD PASADENA CA 91109

<u>NO. OF COPIES</u>	<u>ORGANIZATION</u>	<u>NO. OF COPIES</u>	<u>ORGANIZATION</u>
1	STANFORD UNIVERSITY ATTN DR D BERSHADER DURAND LABORATORY STANFORD CA 94305		<u>ABERDEEN PROVING GROUND</u>
1	UNIVERSITY OF MINNESOTA ARMY HIGH PERF COMP RES CTR ATTN DR TAYFUN E TEZDUYAR 1100 WASHINGTON AVE SOUTH MINNEAPOLIS MN 55415	1	CDR USATECOM ATTN AMSTE TE F L TELETSKI
1	UNIVERSITY OF MINNESOTA ARMY HIGH PERF COMP RES CTR ATTN DR TAYFUN E TEZDUYAR 1100 WASHINGTON AVE SOUTH MINNEAPOLIS MN 55415	1	CDR USATHAMA ATTN AMSTH TE
1	UNIVERSITY OF MINNESOTA ARMY HIGH PERF COMP RES CTR ATTN DR TAYFUN E TEZDUYAR 1100 WASHINGTON AVE SOUTH MINNEAPOLIS MN 55415	1	CDR USATC ATTN STEC LI
3	SOUTHWEST RESEARCH INSTITUTE ATTN DR C ANDERSON S MULLIN A B WENZEL PO DRAWER 28255 SAN ANTONIO TX 78228-0255	26	DIR USARL ATTN AMSRL SC C H BREAUX AMSRL SC CC C NIETUBICZ C ELLIS D HISLEY N PATEL T KENDALL R SHEROKE AMSRL SC I W STUREK AMSRL SC AE M COLEMAN AMSRL SC S R PEARSON AMSRL SL CM E FIORVANTE AMSRL WT N J INGRAM AMSRL WT NA R KEHS AMSRL WT NC R LOTTERO B MCGUIRE A MIHALCIN P MULLER R LOUCKS S SCHRAML AMSRL WT ND J MILETTA AMSRL WT NF L JASPER AMSRL WT NG T OLDHAM AMSRL WT NH J CORRIGAN AMSRL WT PB P WEIHNACHT B GUIDOS AMSRL WT TC K KIMSEY
2	COMMANDER US ARMY NRDEC ATTN SSCNC YSD J ROACH SSCNC WST A MURPHY KANSAS STREET NATICK MA 10760-5018		

USER EVALUATION SHEET/CHANGE OF ADDRESS

This Laboratory undertakes a continuing effort to improve the quality of the reports it publishes. Your comments/answers to the items/questions below will aid us in our efforts.

1. ARL Report Number ARL-CR-229 Date of Report June 1995

2. Date Report Received \_\_\_\_\_

3. Does this report satisfy a need? (Comment on purpose, related project, or other area of interest for which the report will be used.) \_\_\_\_\_  
\_\_\_\_\_  
\_\_\_\_\_

4. Specifically, how is the report being used? (Information source, design data, procedure, source of ideas, etc.) \_\_\_\_\_  
\_\_\_\_\_  
\_\_\_\_\_

5. Has the information in this report led to any quantitative savings as far as man-hours or dollars saved, operating costs avoided, or efficiencies achieved, etc? If so, please elaborate. \_\_\_\_\_  
\_\_\_\_\_  
\_\_\_\_\_

6. General Comments. What do you think should be changed to improve future reports? (Indicate changes to organization, technical content, format, etc.) \_\_\_\_\_  
\_\_\_\_\_  
\_\_\_\_\_

CURRENT ADDRESS

\_\_\_\_\_  
Organization  
\_\_\_\_\_  
Name  
\_\_\_\_\_  
Street or P.O. Box No.  
\_\_\_\_\_  
City, State, Zip Code

7. If indicating a Change of Address or Address Correction, please provide the Current or Correct address above and the Old or Incorrect address below.

OLD ADDRESS

\_\_\_\_\_  
Organization  
\_\_\_\_\_  
Name  
\_\_\_\_\_  
Street or P.O. Box No.  
\_\_\_\_\_  
City, State, Zip Code

(Remove this sheet, fold as indicated, tape closed, and mail.)  
(DO NOT STAPLE)

---

DEPARTMENT OF THE ARMY

OFFICIAL BUSINESS

**BUSINESS REPLY MAIL**  
FIRST CLASS PERMIT NO 0001,APG,MD

POSTAGE WILL BE PAID BY ADDRESSEE

DIRECTOR  
U.S. ARMY RESEARCH LABORATORY  
ATTN: AMSRL-WT-NC  
ABERDEEN PROVING GROUND, MD 21005-5066

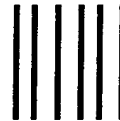

NO POSTAGE  
NECESSARY  
IF MAILED  
IN THE  
UNITED STATES

