

MAILED

MAR 28 1936

To: *Robert C. Platt*

541

NATIONAL ADVISORY COMMITTEE FOR AERONAUTICS

REPORT No. 541

AERODYNAMIC CHARACTERISTICS OF WINGS WITH CAMBERED EXTERNAL-AIRFOIL FLAPS, INCLUDING LATERAL CONTROL WITH A FULL-SPAN FLAP



By ROBERT C. PLATT



DISTRIBUTION STATEMENT A
Approved for public release
Distribution Unlimited

1935

DTIC QUALITY INSPECTED 5

For sale by the Superintendent of Documents, Washington, D. C. Subscription price \$3 per year Price 10 cents

19950829 087

PROPELLER LABORATORY

AERONAUTIC SYMBOLS

1. FUNDAMENTAL AND DERIVED UNITS

	Symbol	Metric		English	
		Unit	Abbreviation	Unit	Abbreviation
Length.....	<i>l</i>	meter.....	m	foot (or mile).....	ft. (or mi.)
Time.....	<i>t</i>	second.....	s	second (or hour).....	sec. (or hr.)
Force.....	<i>F</i>	weight of 1 kilogram.....	kg	weight of 1 pound.....	lb.
Power.....	<i>P</i>	horsepower (metric).....		horsepower.....	hp.
Speed.....	<i>V</i>	kilometers per hour.....	k p.h.	miles per hour.....	m.p.h.
		meters per second.....	m.p.s.	feet per second.....	f.p.s.

2. GENERAL SYMBOLS

- | | |
|--|--|
| <p><i>W</i>, Weight = mg</p> <p><i>g</i>, Standard acceleration of gravity = 9.80665 m/s² or 32.1740 ft./sec.²</p> <p><i>m</i>, Mass = $\frac{W}{g}$</p> <p><i>I</i>, Moment of inertia = mk^2. (Indicate axis of radius of gyration <i>k</i> by proper subscript.)</p> <p><i>μ</i>, Coefficient of viscosity</p> | <p><i>ν</i>, Kinematic viscosity</p> <p><i>ρ</i>, Density (mass per unit volume)</p> <p>Standard density of dry air, 0.12497 kg·m⁻³·s² at 15° C. and 760 mm; or 0.002378 lb.-ft.⁻³·sec.²</p> <p>Specific weight of "standard" air, 1.2255 kg/m³ or 0.07651 lb./cu.ft.</p> |
|--|--|

3. AERODYNAMIC SYMBOLS

- | | |
|--|---|
| <p><i>S</i>, Area</p> <p><i>S_w</i>, Area of wing</p> <p><i>G</i>, Gap</p> <p><i>b</i>, Span</p> <p><i>c</i>, Chord</p> <p><i>b²/<i>S</i></i>, Aspect ratio</p> <p><i>V</i>, True air speed</p> <p><i>q</i>, Dynamic pressure = $\frac{1}{2}\rho V^2$</p> <p><i>L</i>, Lift, absolute coefficient $C_L = \frac{L}{qS}$</p> <p><i>D</i>, Drag, absolute coefficient $C_D = \frac{D}{qS}$</p> <p><i>D_o</i>, Profile drag, absolute coefficient $C_{D_o} = \frac{D_o}{qS}$</p> <p><i>D_i</i>, Induced drag, absolute coefficient $C_{D_i} = \frac{D_i}{qS}$</p> <p><i>C</i>, Cross-wind force, absolute coefficient $C_C = \frac{C}{qS}$</p> <p><i>R</i>, Resultant force</p> | <p><i>i_w</i>, Angle of setting of wings (relative to thrust line)</p> <p><i>i_t</i>, Angle of stabilizer setting (relative to thrust line)</p> <p><i>Q</i>, Resultant moment</p> <p><i>Ω</i>, Resultant angular velocity</p> <p>$\frac{Vl}{\nu}$, Reynolds Number, where <i>l</i> is a linear dimension (e.g., for a model airfoil 3 in. chord, 100 m.p.h. normal pressure at 15° C., the corresponding number is 234,000; or for a model of 10 cm chord, 40 m.p.s. the corresponding number is 274,000)</p> <p><i>C_p</i>, Center-of-pressure coefficient (ratio of distance of c.p. from leading edge to chord length)</p> <p><i>α</i>, Angle of attack</p> <p><i>ε</i>, Angle of downwash</p> <p><i>α_o</i>, Angle of attack, infinite aspect ratio</p> <p><i>α_i</i>, Angle of attack, induced</p> <p><i>γ</i>, Flight-path angle</p> |
|--|---|

REPORT No. 541

**AERODYNAMIC CHARACTERISTICS OF WINGS WITH
CAMBERED EXTERNAL-AIRFOIL FLAPS, INCLUDING
LATERAL CONTROL WITH A FULL-SPAN FLAP**

By **ROBERT C. PLATT**
Langley Memorial Aeronautical Laboratory

1

Accession For	
NTIS	CRA&I <input checked="" type="checkbox"/>
DTIC	TAB <input type="checkbox"/>
Unannounced <input type="checkbox"/>	
Justification	
By	
Distribution /	
Availability Codes	
Dist	Avail and/or Special
A-1	

NATIONAL ADVISORY COMMITTEE FOR AERONAUTICS

HEADQUARTERS, NAVY BUILDING, WASHINGTON, D. C.

LABORATORIES, LANGLEY FIELD, VA.

Created by act of Congress approved March 3, 1915, for the supervision and direction of the scientific study of the problems of flight. Its membership was increased to 15 by act approved March 2, 1929. The members are appointed by the President, and serve as such without compensation.

JOSEPH S. AMES, Ph. D., *Chairman*,
President, Johns Hopkins University, Baltimore, Md.
DAVID W. TAYLOR, D. Eng., *Vice Chairman*,
Washington, D. C.
CHARLES G. ABBOT, Sc. D.,
Secretary, Smithsonian Institution.
LYMAN J. BRIGGS, Ph. D.,
Director, National Bureau of Standards.
BENJAMIN D. FOULLOIS, Major General, United States Army,
Chief of Air Corps, War Department.
WILLIS RAY GREGG, B. A.,
Chief, United States Weather Bureau.
HARRY F. GUGGENHEIM, M. A.,
Port Washington, Long Island, N. Y.
ERNEST J. KING, Rear Admiral, United States Navy,
Chief, Bureau of Aeronautics, Navy Department.

CHARLES A. LINDBERGH, LL. D.,
New York City.
WILLIAM P. MACCRACKEN, Jr., Ph. B.,
Washington, D. C.
AUGUSTINE W. ROBINS, Brig. Gen., United States Army,
Chief, Matériel Division, Air Corps, Wright Field, Dayton,
Ohio.
EUGENE L. VIDAL, C. E.,
Director of Air Commerce, Department of Commerce.
EDWARD P. WARNER, M. S.,
Editor of Aviation, New York City.
R. D. WEYERBACHER, Commander, United States Navy,
Bureau of Aeronautics, Navy Department.
ORVILLE WRIGHT, Sc. D.,
Dayton, Ohio.

GEORGE W. LEWIS, *Director of Aeronautical Research*

JOHN F. VICTORY, *Secretary*

HENRY J. E. REID, *Engineer in Charge, Langley Memorial Aeronautical Laboratory, Langley Field, Va.*

JOHN J. IDE, *Technical Assistant in Europe, Paris, France*

TECHNICAL COMMITTEES

AERODYNAMICS
POWER PLANTS FOR AIRCRAFT
AIRCRAFT STRUCTURES AND MATERIALS

AIRCRAFT ACCIDENTS
INVENTIONS AND DESIGNS

Coordination of Research Needs of Military and Civil Aviation

Preparation of Research Programs

Allocation of Problems

Prevention of Duplication

Consideration of Inventions

LANGLEY MEMORIAL AERONAUTICAL LABORATORY
LANGLEY FIELD, VA.

Unified conduct, for all agencies, of scientific research on the fundamental problems of flight.

OFFICE OF AERONAUTICAL INTELLIGENCE
WASHINGTON, D. C.

Collection, classification, compilation, and dissemination of scientific and technical information on aeronautics.

REPORT No. 541

AERODYNAMIC CHARACTERISTICS OF WINGS WITH CAMBERED EXTERNAL-AIRFOIL FLAPS, INCLUDING LATERAL CONTROL WITH A FULL-SPAN FLAP

By ROBERT C. PLATT

SUMMARY

The results of a wind-tunnel investigation of the N. A. C. A. 23012, the N. A. C. A. 23021, and the Clark Y airfoils, each equipped with a cambered external-airfoil flap, are presented in this report. The purpose of the research was to determine the relative merit of the various airfoils in combination with the cambered flap and to investigate the use of the flap as a combined lateral-control and high-lift device.

Each of the three airfoils was tested in combination with a flap having a chord 20 percent of the main wing chord. The airfoil giving the best characteristics was then tested in combination with a 30-percent-c flap. A satisfactory flap hinge-axis location was selected from the data already obtained and final force and lateral-control tests were made with the 20-percent-c flap hinged at this point. In the lateral-control tests, the flap was cut at the center line of the model so that the semispan flaps could be deflected as ailerons with respect to each other. The flap was also cut at points one-half the semispan from each tip, permitting use of 25 percent of the span on each tip as a combined aileron and flap, the center 50 percent of the span being used solely as a flap.

INTRODUCTION

The increasing benefit to be derived from high-lift devices with improvement in airplane performance has led to a consistent demand for research on methods of obtaining higher maximum lift coefficients without adversely affecting any major items of performance, stability, or control. Various experimental investigations of such devices as pilot planes, slots, and slotted flaps have indicated that airfoils working in juxtaposition may benefit considerably by mutual interference, especially if their relative setting may be varied in such a way as to obtain the optimum interference for each desired characteristic. A fundamental investigation of the foregoing concept (reference 1) has indicated that positions of an auxiliary airfoil

near the leading or trailing edge of a main airfoil offer possibilities of a considerable increase in maximum lift coefficient without adverse effect on other desirable characteristics. In general, users of high-lift devices have tended to favor those near the wing trailing edge, although the practice of placing a true airfoil in this region to get high lift has been confined almost exclusively to Junkers airplanes produced in Germany since 1925. Trailing-edge devices, however, have usually caused the wings to suffer a loss of possible performance through the necessity for lateral control, which has normally been provided by reducing the span of the lift-increasing member to leave room for ailerons at the wing tips. Several devices intended to compensate for this deficiency, such as upper-surface, external, and retractable ailerons, have been investigated but apparently none has yet proved entirely satisfactory in service. Commercial use of Junkers airplanes having the tip portions of the external airfoil capable of deflection as ailerons has shown the practicability of an external-airfoil device combining the functions of ailerons and flaps.

The tests described in the present report were made at the request of the Bureau of Aeronautics, Navy Department. They were intended to provide sufficient information for the design of a full-scale wing embodying the external-airfoil flap as a combined high-lift and lateral control device to be tested in flight. It was further desired to obtain an arrangement sufficiently near the optimum to indicate the true potentialities of this device as compared with others already in use or under development.

Thus far, published results of tests of the external-airfoil type of flap (references 1, 2, 3, and 4) have been more suitable as a guide to possible applications of the device than for use in actual design calculations. Data from a recent investigation of the Fowler flap (reference 5) have served as a useful guide in selecting a desirable size and shape of airfoil section, and a desirable hinge location for the flap, thus permitting

considerable reduction in the research necessary for approximate determination of the maximum capabilities of the device. On the basis of these data, flap chords of 20 percent and 30 percent of the main wing chord were selected as offering the greatest promise of a satisfactory flap arrangement giving both high lift and lateral control. Comparison of the data with those of reference 1 indicates that a cambered (Clark Y) flap has characteristics more favorable to airplane performance than one of symmetrical section. The information on flap loads was judged adequate for the design of the external-airfoil flap structure and controls.

In order to obtain an estimate of the effect of cross-sectional shape and thickness of the main wing, three basic sections were used in the present tests. In addition to the Clark Y, two members of the N. A. C. A. 230 family of airfoils (reference 6), which may be taken as representative of the best airfoils now available for use in conventional airplanes, were selected for testing. From the results obtained, it should be possible to find whether the benefits derived from changing the cross section of a plain wing are equally obtainable from the same change of section of a wing with an external-airfoil flap.

MODELS

Wings.—Three mahogany wing models, each having a span of 60 inches and a chord of 10 inches, were used in the tests. The airfoil sections were the Clark Y, the N. A. C. A. 23021, and the N. A. C. A. 23012, the ordinates of which are subsequently given. (See figs. 24, 25, and 26.) Set into the lower surface near the trailing edge of each model were seven metal strips providing attachments for flap supports and dividing the span into six equal sections.

Flaps.—The two flaps used were made of duralumin and were shaped to the Clark Y profile. They had chords of 2 inches (20 percent of wing chord) and 3 inches and spans of 60 inches. These flaps were hinged to fittings attached to the metal strips in the wing, a series of fittings giving the desired variation of flap position. The term "flap position" is used to designate the location of the flap hinge axis with respect to the main wing. The hinge axis was located at the center of the leading-edge arc of the flap. Flap-angle adjustment was provided by slotted quadrants attached to the flap; the flap could be pivoted about the hinge on the flap-support fittings or locked to the fittings at the desired flap angle by means of set screws through the slots in the quadrants.

TESTS

The tests were made in the N. A. C. A. 7- by 10-foot wind tunnel at Langley Field. Standard force

tests were made on the following series of wing-flap combinations:

1. Clark Y, N. A. C. A. 23012, and N. A. C. A. 23021 wings without flaps.
2. Clark Y wing with 20-percent-*c* Clark Y flap.
3. N. A. C. A. 23012 wing with 20-percent-*c* Clark Y flap.
4. N. A. C. A. 23021 wing with 20-percent-*c* Clark Y flap.
5. N. A. C. A. 23012 wing with 30-percent-*c* Clark Y flap.
6. N. A. C. A. 23012 wing with 20-percent-*c* Clark Y flap cut at the center of the span, each half being deflected as ailerons (semispan ailerons).
7. N. A. C. A. 23012 wing with 20-percent-*c* Clark Y flap cut at the midpoint of each semispan, one-quarter of the span on each tip being deflected as ailerons, the center half span deflected only as a flap (semispan flap, quarterspan ailerons).

The first five sets of tests in the series were made to determine characteristics affecting airplane performance. The maximum lift coefficient of each combination was obtained by taking data at a series of flap positions below the wing trailing edge, at flap angles of 20°, 30°, and 40°, and in one case 60°. A range of flap positions sufficient to determine the one giving maximum lift of each wing-flap combination was covered. The minimum drag coefficients were obtained by taking data for a range of flap angles from 0° to -8°, in 2° steps, at the same positions for which maximum lift was determined.

The sixth and seventh sets of tests were intended to provide data on which to base the selection of an optimum arrangement of the external airfoils as flaps and ailerons. For these tests, a new hinge-axis location was selected and was not varied throughout the tests. Lift, drag, and pitching-moment data were taken at a series of flap angles representing neutral settings from which the ailerons could be deflected. Two types of aileron deflection—equal up-and-down and a typical differential system—were investigated. In addition to the regular lift, drag, and pitching-moment measurements, rolling- and yawing-moment data were obtained at a sufficient number of aileron settings to determine the characteristics given by the two types of deflection from several neutral flap and/or aileron settings. A few tests were made to find the effect of an end plate between the flap and quarterspan ailerons. Hinge-moment data were obtained by measuring the twist of a calibrated torque rod required to balance the flap or aileron at the angle in question. Figures 1 and 2 show the plan and profile arrangements and the hinge positions of the

combinations listed as applied to the N. A. C. A. 23012 wing.

The N. A. C. A. 7- by 10-foot wind tunnel, together with associated apparatus and standard force-test procedure, is described in reference 7. All tests were run at a dynamic pressure of 16.37 pounds per square foot, corresponding to a speed of 80 miles per hour in standard air. The Reynolds Number of the tests, based on the 10-inch chord of the main airfoil, was approximately 609,000.

PRECISION

Thus far, most of the results obtained in the 7- by 10-foot wind tunnel have been intended primarily for comparison among themselves. For this reason no

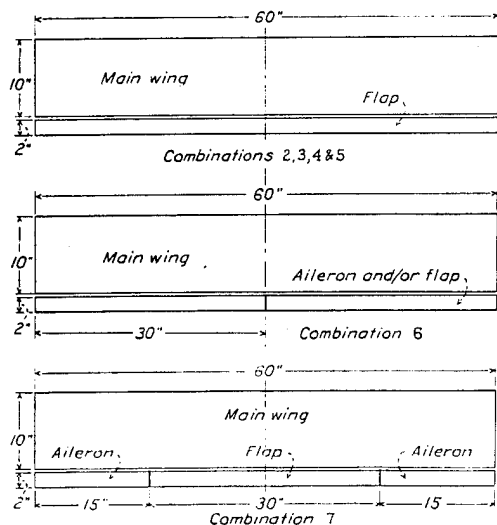

FIGURE 1.—Flap and aileron combinations.

corrections for consistent wind-tunnel errors have been applied to results previously published. Since the present tests involved a departure from the use of the Clark Y section in standard testing in the 7- by 10-foot tunnel, it was considered desirable to make as complete correction for consistent errors as possible in order that the results might be directly comparable with other available airfoil data. The four major sources of consistent discrepancy in the tunnel, as compared with characteristics of full-scale airplane wings, are jet-boundary effect, longitudinal static-pressure gradient, turbulence, and scale. Other sources of consistent error in wind-tunnel tests, such as model

deflection under air load, errors in measurement of tare forces and support interference, and errors in velocity measurement, appear to be of minor importance in the 7- by 10-foot tunnel as compared with the four major sources of consistent errors previously mentioned.

The standard jet-boundary corrections,

$$\Delta\alpha = \delta_a S / C C_L \times 57.3, \text{ degrees}$$

$$\Delta C_D = \delta_D S / C C_L^2$$

where S is the total wing area ($S_w + S_f$), and C the jet cross-sectional area, were used in correcting the test results. The values of the correction factors $\delta_a = \delta_D = -0.165$ are taken as most nearly representative of the boundary effect in this tunnel. The static-pressure gradient produces an additional downstream force on the model, corresponding to a ΔC_D of 0.0015

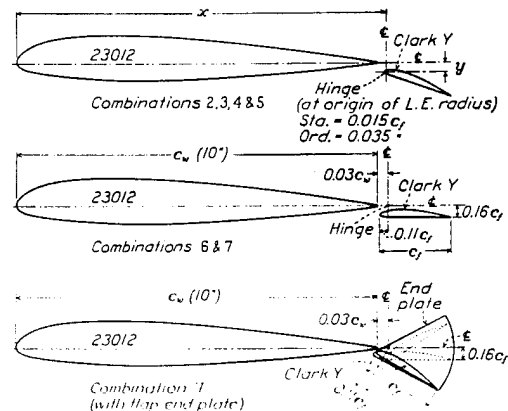

FIGURE 2.—Profiles of flap and aileron combinations.

on 12-percent- c thick rectangular airfoils of the size tested, and ΔC_D of 0.0029 on 21-percent- c thick airfoils. These values were obtained in accordance with the methods given in reference 8. No complete satisfactory corrections for scale and turbulence are at present available, although unpublished data on the turbulence existing in the tunnel indicate its effect on measured airfoil characteristics to be small as compared with the other consistent errors. Reference 6 indicates that the turbulence correction may, in fact, be regarded as approximately equivalent to a scale correction.

A conservative estimate is given in the following table of the accidental errors in the tests, obtained principally from comparison of data taken at intervals

over a period of several years on a duralumin wing model:

- $\alpha \pm 0.10^\circ$
- $C_{L_{max}} \pm 0.05$
- $C_{m_{a.c.}} \pm 0.008$
- $C_D(C_L=0) \pm 0.001$
- $C_D(C_L=1) \pm 0.004$
- $C_D(C_L=2) \pm 0.008$
- $C_H \pm 0.0002$
- Flap angle $\pm 0.25^\circ$
- Flap position $\pm 0.0015c_w$

RESULTS AND DISCUSSION

Form of presentation of results.—All test results have been reduced to standard nondimensional coefficient form, based on the total area (plan area of wing + plan area of flap). This convention is based on the concept that the nominal wing area of an airplane is the area used for normal cruising flight.

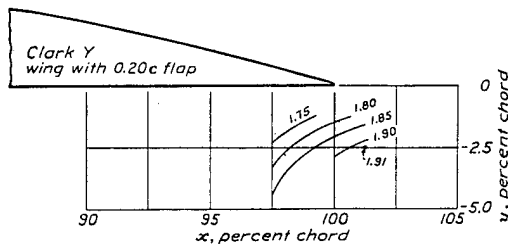

FIGURE 3.—Contours showing variation of $C_{L_{max}}$ with flap position. $\delta_f = 20^\circ$
Plain wing $C_{L_{max}} = 1.300$.

The coefficients are defined as follows:

subscript w refers to the main airfoil

subscript f refers to the flap

$$C_L = \text{Lift}/q (S_w + S_f)$$

$$C_D = \text{Drag}/q (S_w + S_f)$$

$$C_m = \text{Pitching moment}/q (S_w + S_f) (c_w + c_f)$$

$$C_l' = \text{Rolling moment}/q (S_w + S_f) b_w$$

$$C_n' = \text{Yawing moment}/q (S_w + S_f) b_w$$

$$C_H = \text{Flap or aileron hinge moment}/q (S_w + S_f) (c_w + c_f)$$

$$CF = \text{Control-stick hinge moment}/q C_L (S_w + S_f) (c_w + c_f)$$

or $CF = (\delta/25^\circ) \times (C_H/C_L)$, where δ is the angular deflection of the aileron drive crank.

δ_f , flap deflection, degrees.

δ_{AR} , right aileron deflection, degrees.

δ_{AL} , left aileron deflection, degrees.

The sign conventions used for flap angle and hinge-moment coefficient are the same as the standard conventions for angle of attack and pitching-moment coefficient, respectively. The flap angle is measured between the wing and flap chord lines. It should be noted that the rolling- and yawing-moment coefficients, C_l' and C_n' , refer to wind axes. The flap

hinge-moment coefficient C_H is based on total wing area and total chord (main wing plus flap) rather than on flap area and chord so that the present results may be directly comparable with published data on stickforce coefficients to which subsequent reference is made.

In order that the final lift and drag characteristics of the selected wing-flap combination may be directly comparable with similar plain airfoil data, the results of the tests on the wing-flap combinations have been corrected to an aspect ratio of 6. Since the coefficients for the airfoil with a 20-percent- c flap are based on a span of 60 inches and a chord of 12 inches, the test aspect ratio of the combination was 5, but this discrepancy with the plain airfoil tests has been eliminated from the final lift and drag data.

The pitching-moment coefficients in the final airfoil data are referred to the aerodynamic center, about which the value of C_m is sensibly constant throughout the range from zero to maximum lift. In the case of the airfoils with flap deflected, however, the pitching-moment coefficients are referred to the aerodynamic center for the flap neutral setting. This method avoids the use of a varying aerodynamic center for a wing with a flap but, of course, the value of $C_{m_{a.c.}}$ is no longer constant in the specified range with the flap deflected from the neutral setting.

Determination of optimum flap arrangement.—The purpose of the initial series of tests, comprising the first five groups previously listed, was to find which of several airfoil sections would give the best combination with a cambered external-airfoil flap. For the selection, factors affecting only airplane performance were used as criterions.

Contours showing the variation of each of several airfoil characteristics with the location of the flap hinge axis are plotted for the Clark Y wing with 0.20c flap in figures 3 to 7, for the N. A. C. A. 23021 with 0.20c flap in figures 8 to 12, and for the N. A. C. A. 23012 with 0.20c and 0.30c flaps in figures 13 to 23, inclusive. The value of any characteristic shown at a certain point with respect to the wing trailing edge was that obtained with the flap hinge axis located at that point. The hinge axis was located at the center of the leading-edge arc on the flap. Airfoil characteristics considered in this way are $C_{L_{max}}$, $C_{D_{min}}$, and a speed-range index, $C_{L_{max}}/C_{D_{min}}$. The contours of $C_{L_{max}}$ are confined to constant flap angle, the data for different flap angles being shown in different figures. The flap angle for minimum C_D was within $\pm 1^\circ$ of -5° in all cases. $C_{L_{max}}/C_{D_{min}}$ is plotted as independent of flap angle, the values of $C_{L_{max}}$ and $C_{D_{min}}$ being selected at the optimum angle for each, at the flap position in question.

Complete aerodynamic characteristics of the three model airfoils without flaps are given in figures 24, 25,

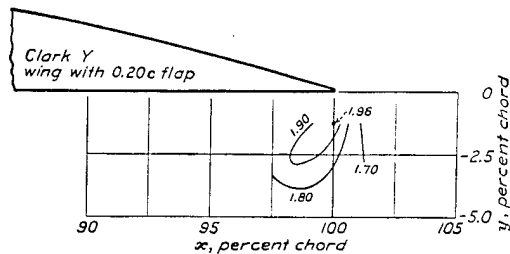

FIGURE 4.—Contours showing variation of $C_{l_{max}}$ with flap position. $\delta_f=30^\circ$. Plain wing $C_{l_{max}}=1.300$.

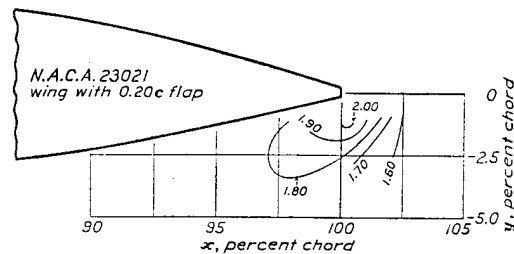

FIGURE 9.—Contours showing variation of $C_{l_{max}}$ with flap position. $\delta_f=30^\circ$. Plain wing $C_{l_{max}}=1.208$.

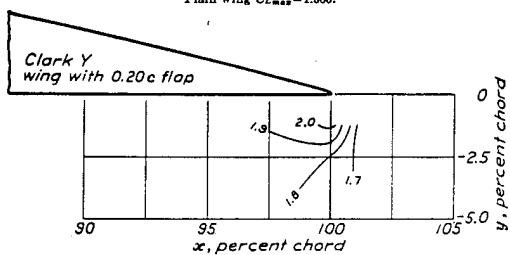

FIGURE 5.—Contours showing variation of $C_{l_{max}}$ with flap position. $\delta_f=40^\circ$. Plain wing $C_{l_{max}}=1.300$.

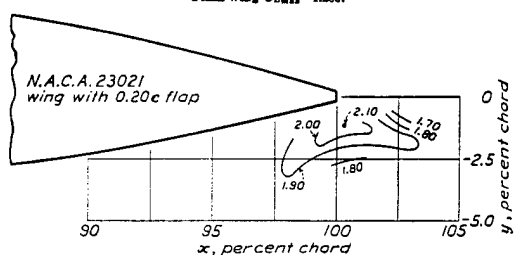

FIGURE 10.—Contours showing variation of $C_{l_{max}}$ with flap position. $\delta_f=40^\circ$. Plain wing $C_{l_{max}}=1.208$.

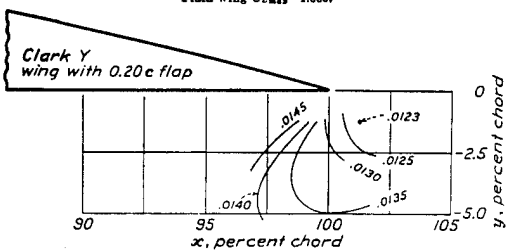

FIGURE 6.—Contours showing variation of $C_{d_{min}}$ with flap position. Plain wing $C_{d_{min}}=0.0145$.

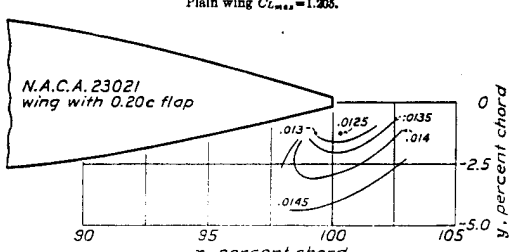

FIGURE 11.—Contours showing variation of $C_{d_{min}}$ with flap position. Plain wing $C_{d_{min}}=0.0153$.

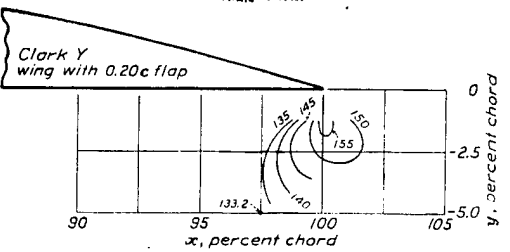

FIGURE 7.—Contours showing variation of $C_{l_{max}}/C_{d_{min}}$ with flap position. Plain wing $C_{l_{max}}/C_{d_{min}}=89.6$.

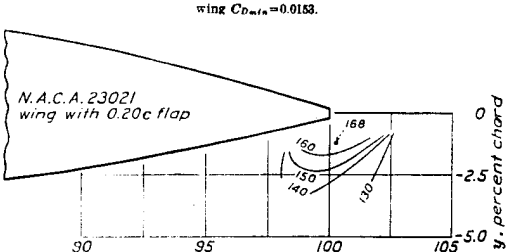

FIGURE 12.—Contours showing variation of $C_{l_{max}}/C_{d_{min}}$ with flap position. Plain wing $C_{l_{max}}/C_{d_{min}}=78.8$.

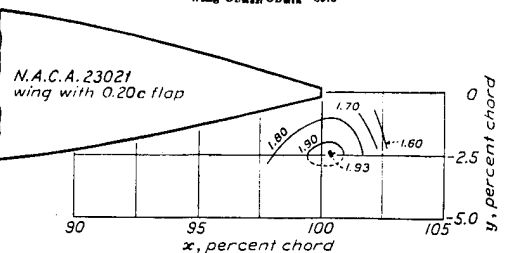

FIGURE 8.—Contours showing variation of $C_{l_{max}}$ with flap position. $\delta_f=20^\circ$. Plain wing $C_{l_{max}}=1.208$.

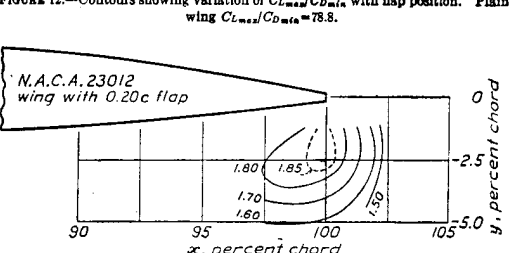

FIGURE 13.—Contours showing variation of $C_{l_{max}}$ with flap position. $\delta_f=20^\circ$. Plain wing $C_{l_{max}}=1.145$.

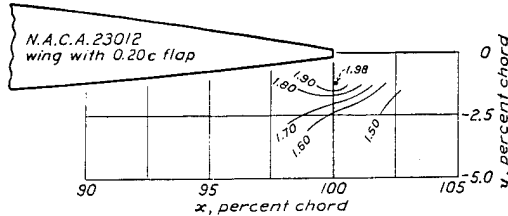

FIGURE 14.—Contours showing variation of Cl_{max} with flap position. $\delta_f=30^\circ$. Plain wing $Cl_{max}=1.145$.

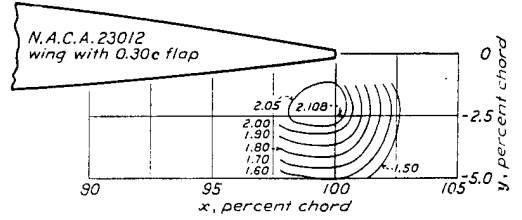

FIGURE 19.—Contours showing variation of Cl_{max} with flap position. $\delta_f=30^\circ$. Plain wing $Cl_{max}=1.145$.

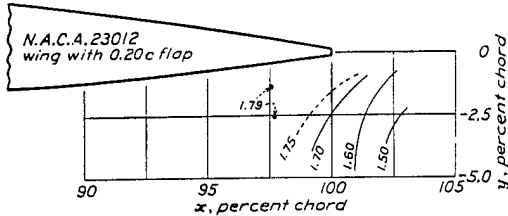

FIGURE 15.—Contours showing variation of Cl_{max} with flap position. $\delta_f=40^\circ$. Plain wing $Cl_{max}=1.145$.

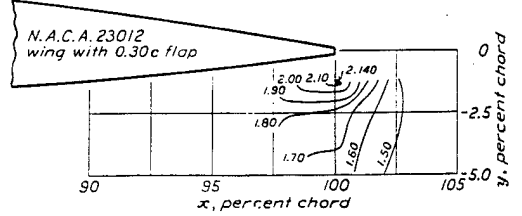

FIGURE 20.—Contours showing variation of Cl_{max} with flap position. $\delta_f=40^\circ$. Plain wing $Cl_{max}=1.145$.

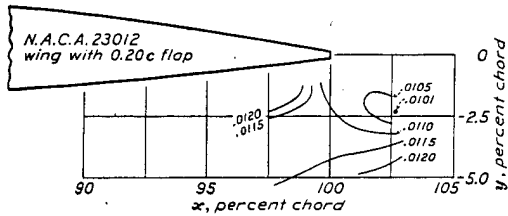

FIGURE 16.—Contours showing variation of Cb_{min} with flap position. Plain wing $Cb_{min}=0.0105$.

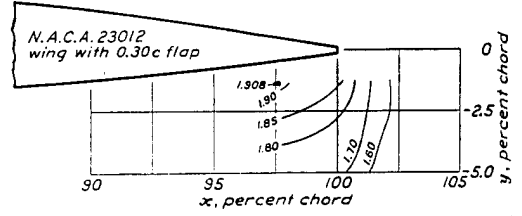

FIGURE 21.—Contours showing variation of Cl_{max} with flap position. $\delta_f=60^\circ$. Plain wing $Cl_{max}=1.145$.

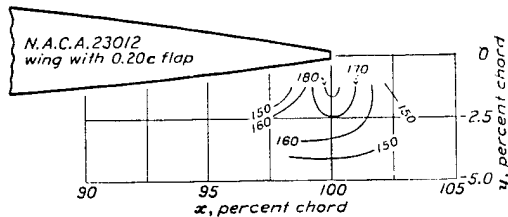

FIGURE 17.—Contours showing variation of $Cl_{max}/C_{b_{min}}$ with flap position. Plain wing $Cl_{max}/C_{b_{min}}=109.0$.

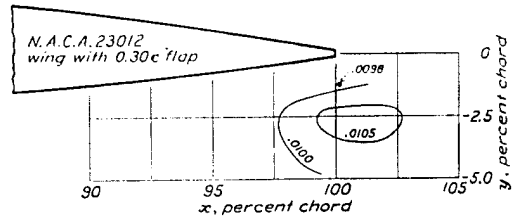

FIGURE 22.—Contours showing variation of Cb_{min} with flap position. Plain wing $Cb_{min}=0.0105$.

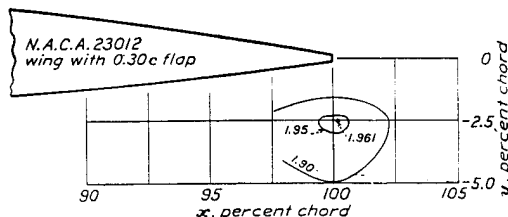

FIGURE 18.—Contours showing variation of Cl_{max} with flap position. $\delta_f=20^\circ$. Plain wing $Cl_{max}=1.145$.

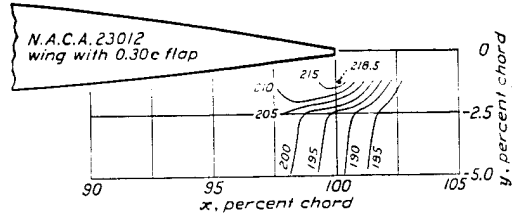
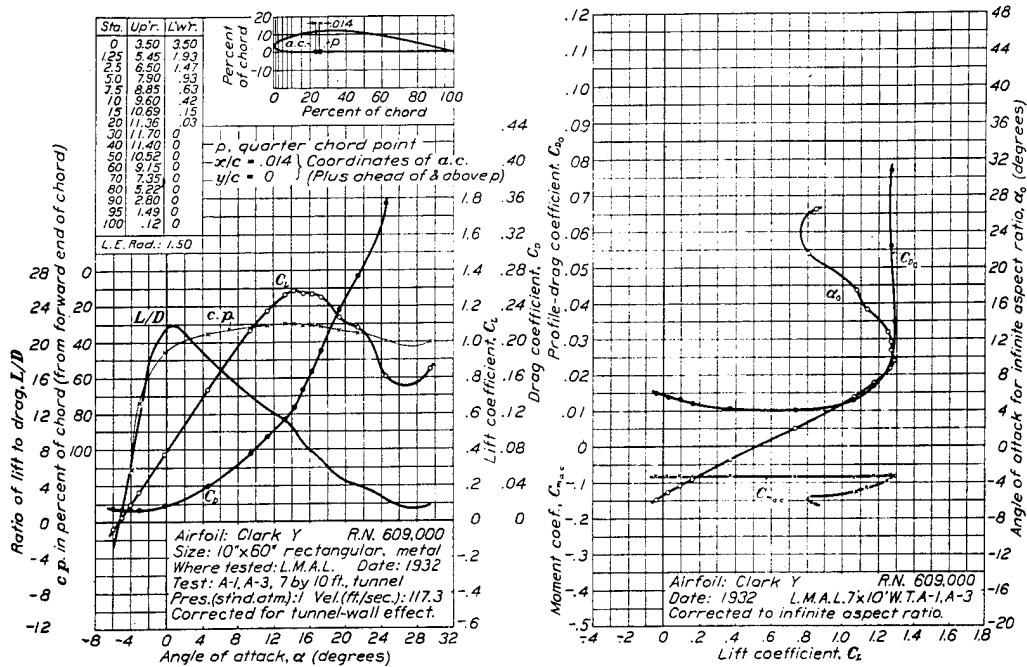
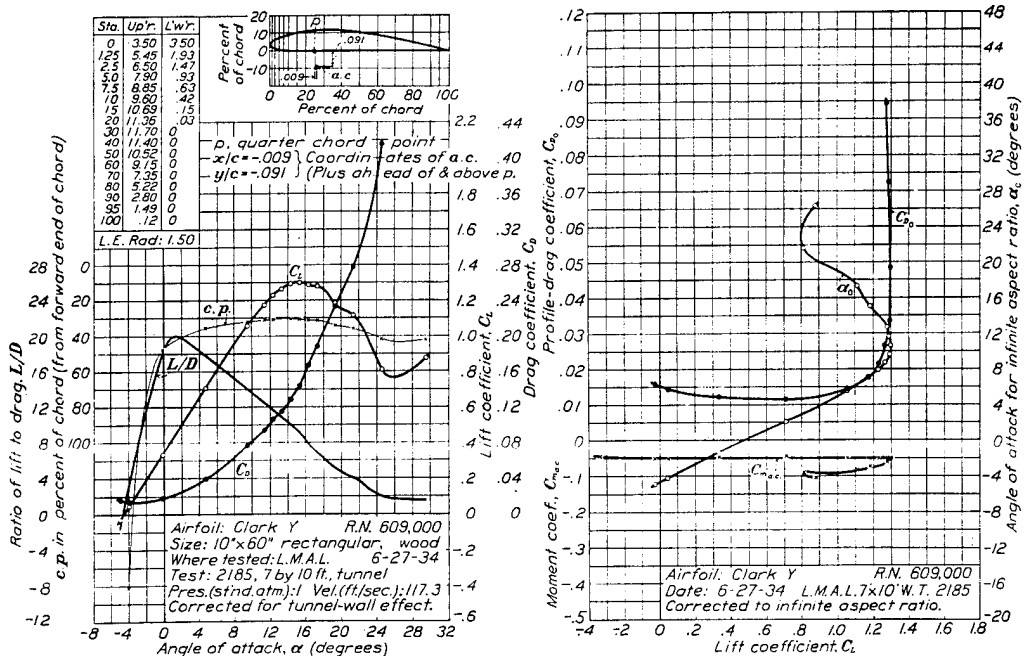

FIGURE 23.—Contours showing variation of $Cl_{max}/C_{b_{min}}$ with flap position. Plain wing $Cl_{max}/C_{b_{min}}=109.0$.



(a) Metal airfoil



(b) Wooden airfoil

FIGURE 24.—The Clark Y airfoil.

and 26. Figure 24 (a) shows data for a standard duralumin Clark Y airfoil model used in checking tunnel calibration and figure 24 (b) shows data for the wooden Clark Y model actually used with the external-airfoil flaps. The difference in characteristics is ascribed to the use of blocks inserted under a sheet-metal upper surface to form the rear portion of the wooden model, which appears to have a smaller camber near the trailing edge than the duralumin model. For comparison with other airfoil data, those given in figure 24 (a) are considered more representative of results in the 7- by 10-foot tunnel. For estimation of the effect of adding an external-airfoil flap to a Clark Y wing, the data of figure 24 (b) should be used, since the same model was used for the tests with the flaps. The foregoing discrepancy in the plain Clark Y airfoils does not exist in the case of the N. A. C. A. 23012 and N. A. C. A. 23021 plain airfoil models. These models were shaped to the correct profile within the limits of accuracy normally specified for models used in the 7- by 10-foot tunnel.

Comparison of the contours of $C_{L_{max}}/C_{D_{min}}$ for the different airfoils with a 20-percent-*c* flap indicates that the N. A. C. A. 23012 wing offers the greatest possible improvement for the combinations tested. Some tests in the full-scale and variable-density wind tunnels (reference 6) indicate that the N. A. C. A. 23012 airfoil alone has a greater $C_{L_{max}}$ than the Clark Y in the normal full-scale range of Reynolds Numbers, although the reverse is true at the Reynolds Number of the present tests. Some existing experimental evidence indicates this scale-effect relation to apply with flaps on the airfoils, as well as without. It seems reasonable to expect, therefore, that in the full-scale range the N. A. C. A. 23012 with an external flap has an even greater advantage over the Clark Y with an external flap than is indicated by the present tests. The N. A. C. A. 23012 was therefore chosen as representative of the optimum airfoil for combination with an external-airfoil flap. Of the other two airfoils tested, the N. A. C. A. 23021 appears the better. The probability of encountering excessive control forces led to the selection of the 0.20*c* flap for use in combination with the N. A. C. A. 23012 airfoil in the final series of tests; an extensive investigation to reduce the flap hinge moments to a minimum did not seem justified at the present stage of development.

Selection of optimum flap hinge axis.—Since the location of the hinge axis in the leading edge of the flap is not practicable because of the large operating forces required, it was necessary to select a more suitable hinge-axis location for low hinge moments before proceeding with the lateral control tests. Inasmuch as the Fowler type of flap when extended shows characteristics very similar to those of the external-airfoil flap, it was considered reasonable to base the selection of the hinge-axis location on the flap-load data of reference 5. The most forward position of the resultant-force vector

on the flap was taken as the optimum line on which to locate the hinge with respect to the flap. The contours in figures 13 to 17 were then used to determine the most favorable position of the flap leading edge with respect to the wing at each of several flap angles over the desired range. From the foregoing information, a compromise location of the hinge with respect to both wing and flap was chosen, which was expected to give good over-all characteristics throughout a range of flap angles from -5° to 30° . The profile of this arrangement, including hinge-axis position, is that shown in figure 2 for combinations 6 and 7.

Aerodynamic characteristics of the wing-flap combination with the flap at angles of -5° , 20° , and 30° , using the selected hinge-axis location, are given in figures 27, 28, and 29. These angles were used as neutral settings, from which the ailerons were deflected to obtain rolling- and yawing-moment data. A test of a neutral setting with the semispan flap at an angle of 30° and the quarterspan ailerons at 10° showed this arrangement to have essentially the same lift and drag characteristics as the arrangement with both flap and ailerons set at 20° . Lift and drag data for a neutral setting of flap angle 30° and aileron angle of 20° were obtained by interpolation.

Results of lateral control tests.—In order to reduce the number of tests required, it was assumed that the rolling- and yawing-moment coefficients produced by a given deflection of one aileron were independent of the setting of the other aileron. Preliminary tests indicated the assumption to be sufficiently accurate to satisfy the purpose of the present investigation. Representative curves are shown in figure 30.

Results of several tests made to determine the effect of an end plate between the flap and the quarterspan ailerons are shown in figures 31 and 32 as rolling- and yawing-moment coefficients of three aileron combinations with and without an end plate. As the end plate apparently produced a negligible effect, it was eliminated from further tests.

The lateral control tests of combination 6 (fig. 1) with each aileron covering the wing semispan gave the results shown in figures 33 and 34. Figure 33 shows the rolling-moment coefficients produced by various deflections of the left aileron, with the right aileron at an angle of -5° . The rolling-moment coefficient produced by any combined deflection may then be found by the method used in the following example: For a setting of right aileron at -20° , left aileron at 20° , C_l' is equal to the algebraic difference between C_l' for $\delta_{AL}=20^\circ$, $\delta_{AR}=-5^\circ$, and C_l' for $\delta_{AL}=-20^\circ$, $\delta_{AR}=-5^\circ$. Using data for $\alpha=10^\circ$ from figure 33:

$$\begin{aligned} C_l'(\delta_{AL}=20^\circ, \delta_{AR}=-5^\circ) &= 0.0735 \\ C_l'(\delta_{AL}=-20^\circ, \delta_{AR}=-5^\circ) &= -0.0300 \\ C_l'(\delta_{AL}=20^\circ, \delta_{AR}=-20^\circ) &= 0.0735 - (-0.0300) \\ &= 0.1035 \end{aligned}$$

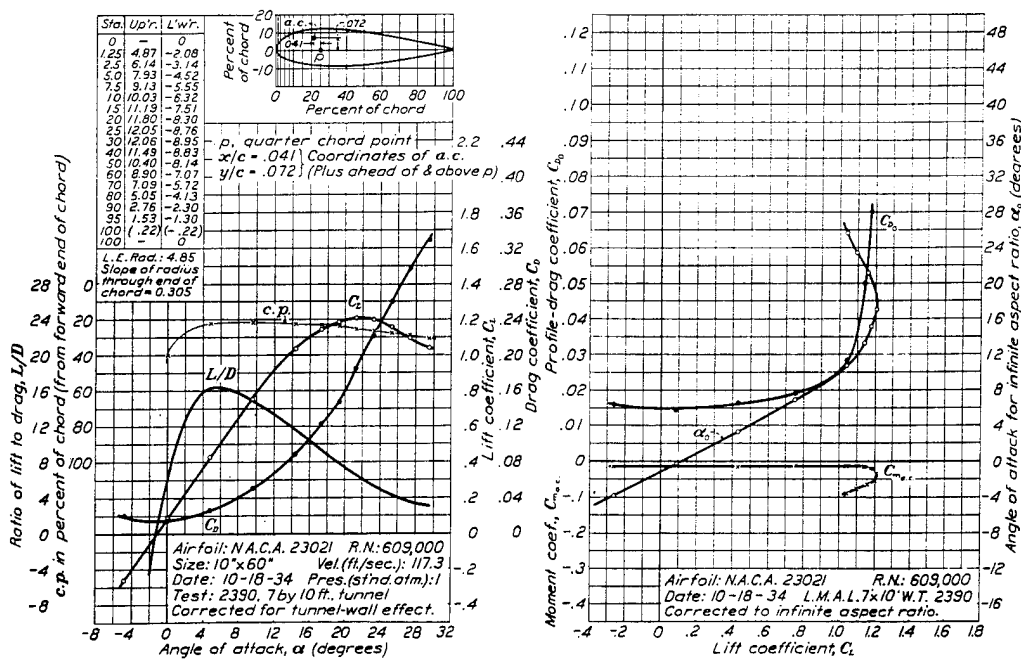

FIGURE 25.—The N. A. C. A. 23021 airfoil.

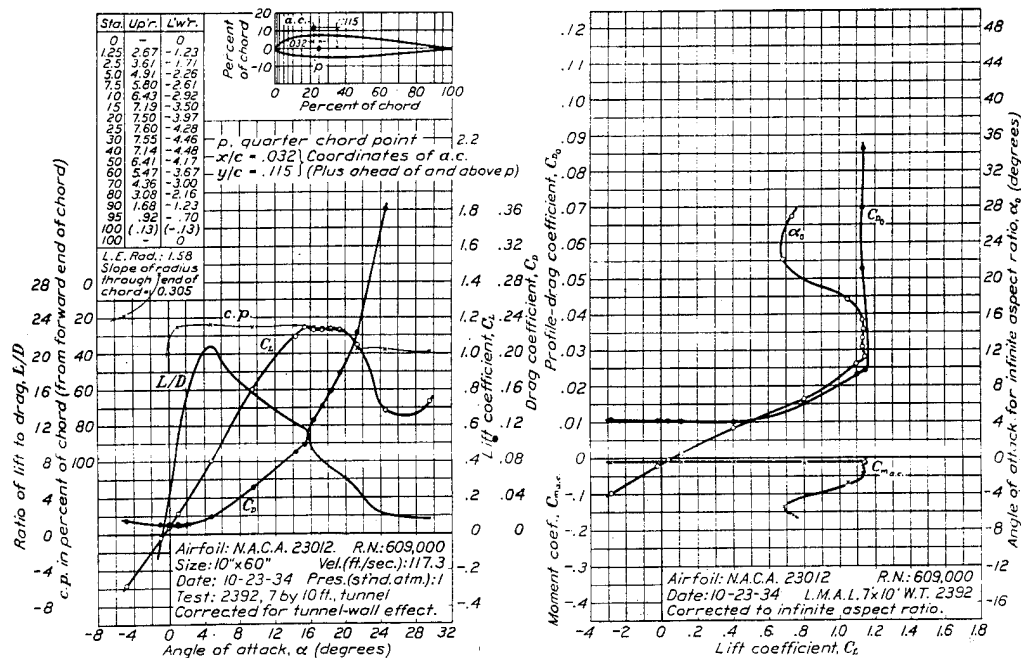

FIGURE 26.—The N. A. C. A. 23012 airfoil.

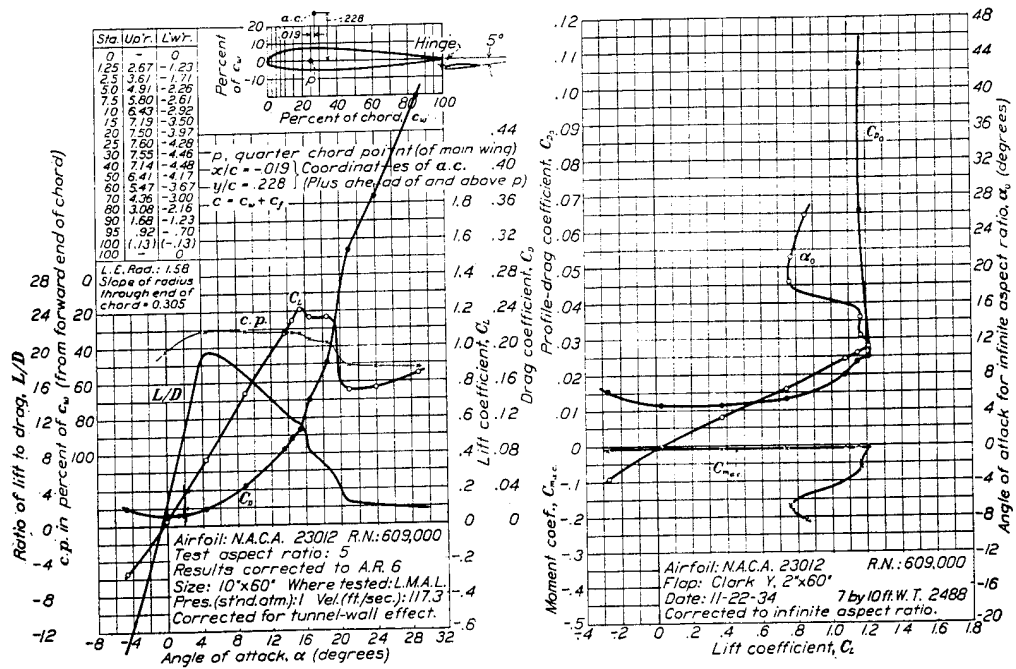

FIGURE 27.—The N. A. C. A. 23012 airfoil with 0.20 c Clark Y flap, $\delta_f = 5^\circ$.

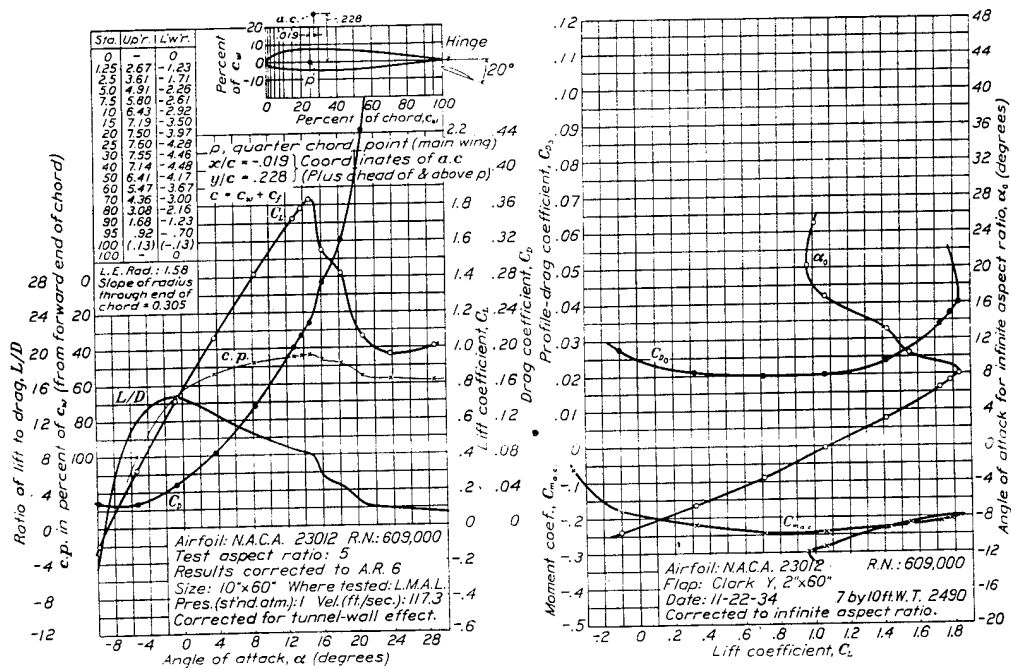

FIGURE 28.—The N. A. C. A. 23012 airfoil with 0.20 c Clark Y flap, $\delta_f = 20^\circ$.

Corresponding values of yawing-moment coefficient may be obtained from figure 34, using the same method.

The tests of combination 7 (fig. 1), quarterspan ailerons and semispan flap, gave the results shown in figures 35 to 40. These figures show rolling- and yawing-moment coefficients as a function of left aileron angle (δ_{AL}) for three settings of the flap and right aileron. Control given by any assumed combination may be computed as previously explained, using the flap and right aileron setting most nearly corresponding to the assumed arrangement.

Hinge-moment coefficients as a function of angular deflection are shown in figure 41 for a semispan flap or aileron. The coefficients refer to moments measured on an aileron having a span equal to one-half the

same deflection of the semispan aileron. From the magnitudes of C_H obtained on the flap with the finally selected hinge position, it appears that the method of selection employed was conservative and that the hinge axis might be located somewhat farther back on the flap without involving overbalance in any part of the operating range.

Determination of optimum lateral control arrangement.—A number of possible arrangements were compared in selecting the final one recommended as a promising high-lift and lateral control device. The following combinations were investigated:

1. Semispan ailerons, equal up-and-down deflection. Neutral setting, 20°.

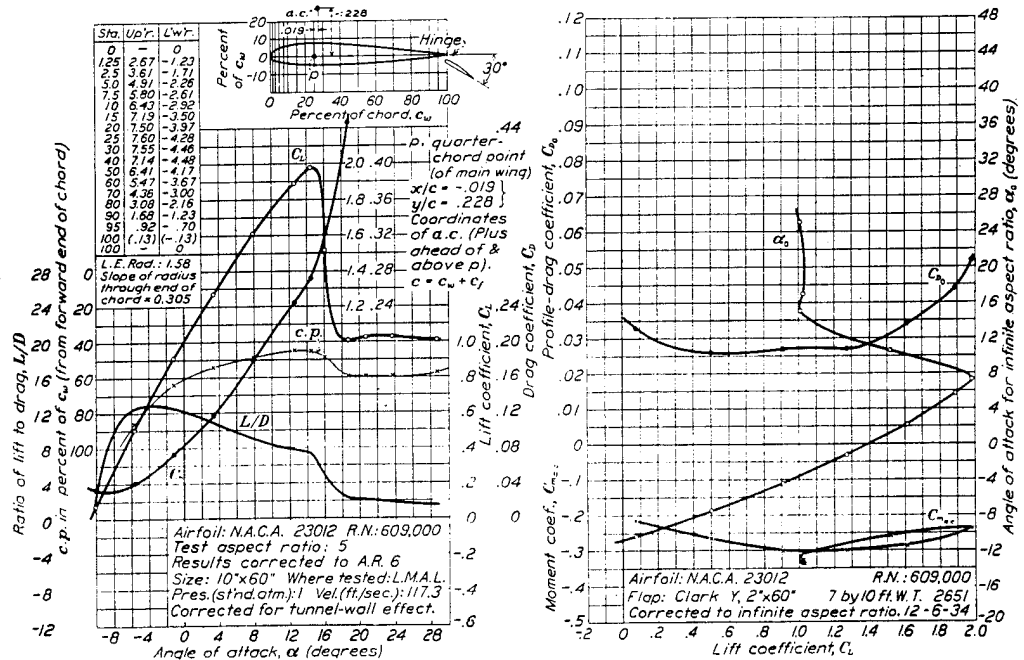

FIGURE 20.—The N. A. C. A. 23012 airfoil with 0.20 c Clark Y flap, $\delta_f = 30^\circ$.

wing span. The value of C_H for a setting $\delta_{AR} = -20^\circ$, $\delta_{AL} = 20^\circ$ is then the algebraic difference between C_H for $\delta_A = 20^\circ$ and C_H for $\delta_A = -20^\circ$, at the angle of attack in question, on the semispan ailerons. When computing the values of the control-force criterion (CF) of the differential deflection described later, the values of C_H for each of the ailerons at its deflected position must be obtained separately and be divided by the mechanical advantage of the differential linkage at the deflected position of the aileron before they are added to obtain the total C_H . For a given deflection of a quarterspan aileron, C_H is equal to half that for

2. Quarterspan ailerons, equal up-and-down deflection. Neutral setting 20°, flap 20°.
3. Quarterspan ailerons, equal up-and-down deflection. Neutral setting 10°, flap 30°.
4. Quarterspan ailerons, equal up-and-down deflection. Neutral setting 20°, flap 30°.
5. Semispan ailerons, equal up-and-down deflection. Neutral setting 30°.
6. Semispan ailerons, differential deflection. Neutral setting 20°.
7. Semispan ailerons, differential deflection. Neutral setting 30°.

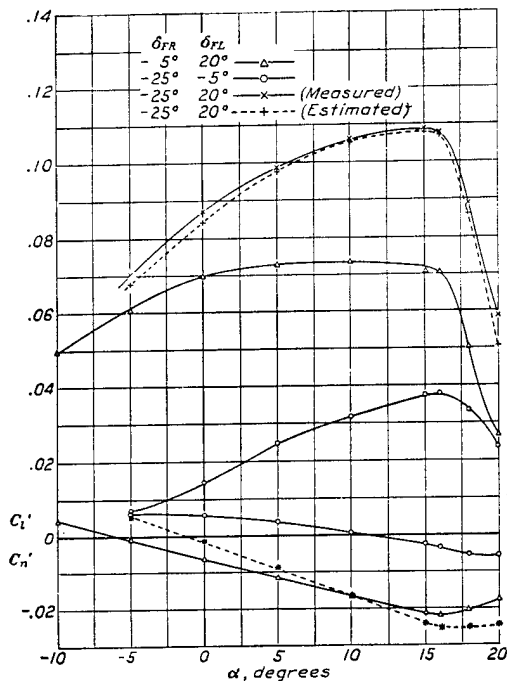

FIGURE 30.— C_l and C_n , 0.20 c Clark Y flaps on N. A. C. A. 23012 wing. Semispan ailerons deflected separately and together.

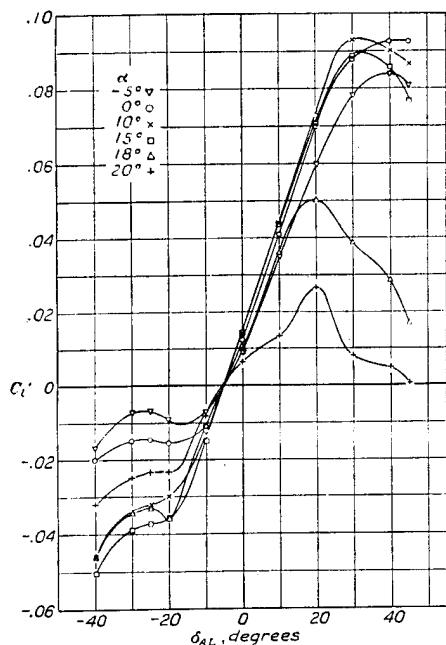

FIGURE 33.— C_l , N. A. C. A. 23012 wing with external-airfoil flaps and ailerons (0.20 c flap). $\delta_{AR} = -5^\circ$. Aileron span = $b/2$.

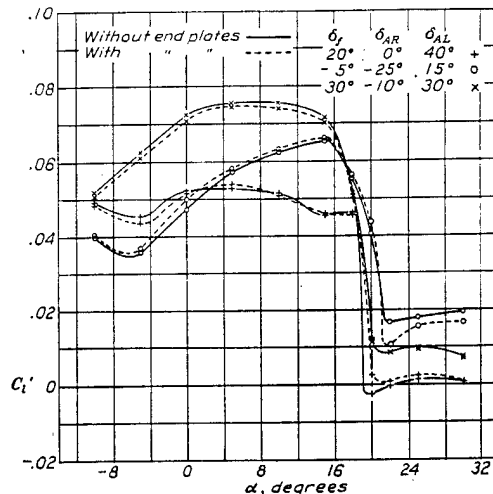

FIGURE 31.— C_l , N. A. C. A. 23012 wing with external-airfoil flaps and ailerons (0.20 c flap). Aileron span = $b/4$.

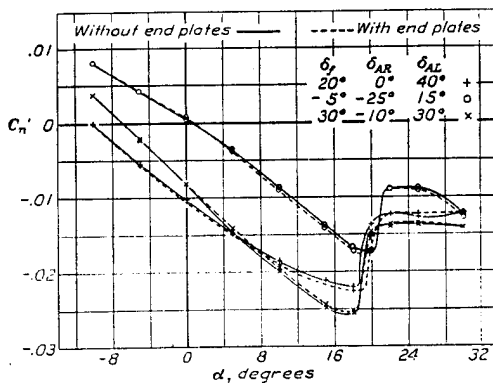

FIGURE 32.— C_n , N. A. C. A. 23012 wing with external-airfoil flaps and ailerons (0.20 c flap). Aileron span = $b/4$.

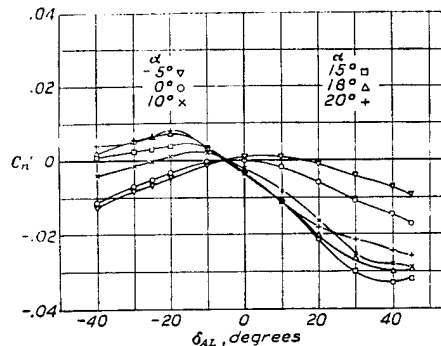

FIGURE 34.— C_n , N. A. C. A. 23012 wing with external-airfoil flaps and ailerons (0.20 c flap). $\delta_{AR} = -5^\circ$. Aileron span = $b/2$.

- 8. Quarterspan ailerons, differential deflection. Neutral setting 30°, flap 30°.
- 9. Quarterspan ailerons, differential deflection. Neutral setting 20°, flap 30°.
- 10. Quarterspan ailerons, differential deflection. Neutral setting 10°, flap 30°.

The criteria used in comparison, together with appropriate values for the various combinations, appear in table I.
The tabulated item C_l' ($C_L=1.0, 1.7; \delta_A=40^\circ$ difference) is taken as a measure of the rolling-moment coefficient obtainable at normal gliding speeds with a

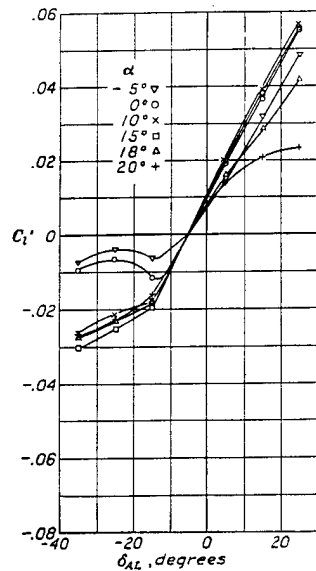

FIGURE 35.— C_l' , N. A. C. A. 23012 wing with external-airfoil flaps and ailerons (0.20 c flap). $\delta_f = -5^\circ; \delta_{AR} = -5^\circ$; aileron span = $b/4$.

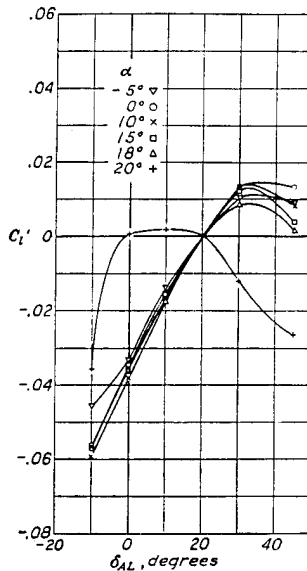

FIGURE 37.— C_l' , N. A. C. A. 23012 wing with external-airfoil flaps and ailerons (0.20 c flap). $\delta_f = 20^\circ; \delta_{AR} = 20^\circ$; aileron span = $b/4$.

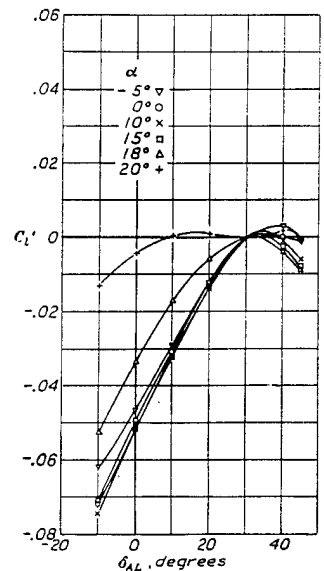

FIGURE 39.— C_l' , N. A. C. A. 23012 wing with external-airfoil flaps and ailerons (0.20 c flap). $\delta_f = 30^\circ; \delta_{AR} = 30^\circ$; aileron span = $b/4$.

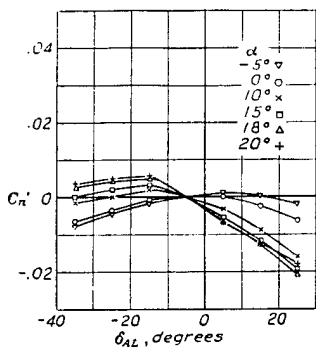

FIGURE 36.— C_n' , N. A. C. A. 23012 wing with external-airfoil flaps and ailerons (0.20 c flap). $\delta_f = -5^\circ; \delta_{AR} = -5^\circ$; aileron span = $b/4$.

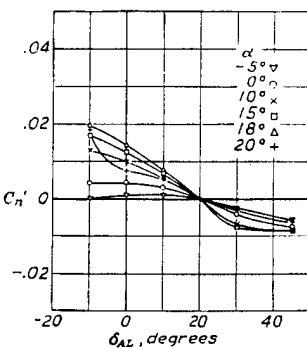

FIGURE 38.— C_n' , N. A. C. A. 23012 wing with external-airfoil flaps and ailerons (0.20 c flap). $\delta_f = 20^\circ; \delta_{AR} = 20^\circ$; aileron span = $b/4$.

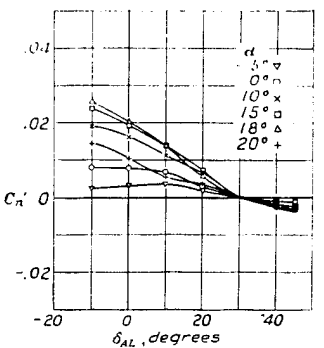

FIGURE 40.— C_n' , N. A. C. A. 23012 wing with external-airfoil flaps and ailerons (0.20 c flap). $\delta_f = 30^\circ; \delta_{AR} = 30^\circ$; aileron span = $b/4$.

- 11. Semispan ailerons, equal up-and-down deflection. Neutral setting -5° .
- 12. Semispan ailerons, differential deflection. Neutral setting -5° .
- 13. Quarterspan ailerons, equal up-and-down deflection. Neutral setting -5° , flap -5° .
- 14. Quarterspan ailerons, differential deflection. Neutral setting -5° , flap -5° .

reasonable deflection of the ailerons. The expression $\delta_A = 40^\circ$ difference signifies an equal up-and-down neutral setting of 20° from neutral and a differential setting such that the angle between the ailerons is 40° .
The essential features of the differential linkage are shown in figure 42. This linkage is designated "differential no. 2" in reference 9. The computations of CF were made in accordance with the system

used in reference 9 and give comparable results. The values of CF given compare directly the lateral stick forces required to give a certain value of the rolling-moment coefficient at a certain lift coefficient with the same lateral stick position.

The tabulated item C_H' is the yawing-moment coefficient accompanying the rolling-moment coefficient

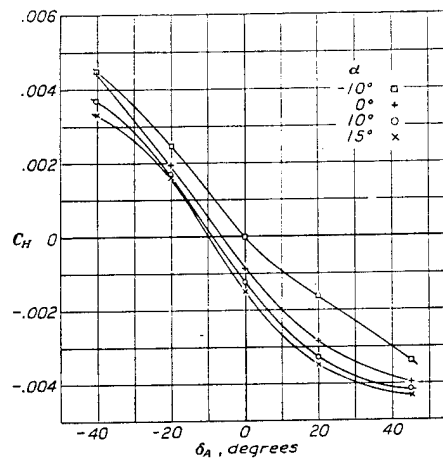

FIGURE 41.— C_H' against δ_A , N. A. C. A. 23012 wing with a 0.20 c external-airfoil flap deflected as an aileron. Aileron span = $b/2$.

at each condition for which CF was computed. The yawing moments were adverse in all cases, the term "adverse" being used to signify a negative yawing moment accompanying a positive rolling moment, or vice versa.

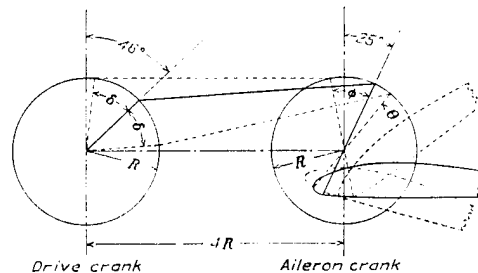

FIGURE 42.—Differential linkage (see reference 9). N. A. C. A. 23012 wing with 0.20 c chord external-airfoil flaps and ailerons.

Drive crank angle, up and down, δ (degrees)	Aileron crank angle down, θ (degrees)	Aileron crank angle, up ϕ , (degrees)	K' Aileron down	K' Aileron up
0	0	0	0.70	0.70
10	5.5	7.5	.59	.81
20	10.4	16.0	.42	.90
30	13.0	23.5	0	.97
40	13.1	35.5	-.08	1.02

Mechanical advantage of drive crank, $1/K$.

It appears at once from inspection of the table that most of the differential arrangements cannot be used in the conventional manner on account of the overbalance encountered at high and even medium lift coefficients. From the usable arrangements, nos. 10 and 3 may be selected as the most promising lateral control devices, in the order named. They give as large maximum available rolling moments as the best other arrangements, excluding overbalance, and have smaller adverse yawing moments than any others which have nearly as much rolling power. Of the two, no. 10 is considered better because of the considerably lower operating forces required. The sole disadvantage of these two arrangements consists of their effect on the maximum lift coefficient, the maximum value being 1.80, as compared with the maximum obtainable value of 1.98 for this type of flap.

Several features of the differential arrangements that become overbalanced indicate the desirability of investigating them further. No. 6, for example, gives greater rolling power than any other arrangement and very small values of CF , and no. 7 gives the full obtainable maximum lift coefficient with apparently usable, though not good, lateral control. If the overbalance could be eliminated, both of these arrangements should be of considerable interest.

The source of the overbalance lies in the tendency of the ailerons to float at a large negative angle from their neutral setting (when the neutral setting is 20° or 30° down). As an example of what occurs, it will be seen that when the down-going aileron drive crank reaches dead center, the aileron produces no restoring moment at the stick and, if the up-going aileron has not yet reached its floating angle, the system is overbalanced.

It appears that the application of springs to make each aileron float down from its normal floating position, or the provision of a return spring in the operating system, can be used to eliminate the overbalance. Since the degree of overbalance decreases with lift coefficient, it is evident that the maximum spring force is required at the minimum air speed, and the controls will tend to stiffen with increasing air speed in a normal manner. Proper selection of a spring can thus be made to give almost zero stick forces at minimum speed, and small stick forces throughout the flight range.

Comparison of external-airfoil ailerons with ordinary ailerons.—Some calculated values of rolling-moment, yawing-moment, and stick-force coefficients for small and large deflections of external-airfoil and ordinary ailerons are shown in the following table. Data for semispan external-airfoil ailerons with the wing at lift coefficients of 1.0 and 1.7 were used, an equal up-and-down deflection from a neutral setting of 20° being assumed. Data for 15-percent- c by 60-percent- $b/2$ ordinary ailerons having an equal up-and-down deflection were obtained from reference 9. No at-

tempt has been made to correct for differences in chord and span of the two types of aileron, the comparison being made directly between the actual sizes and types tested.

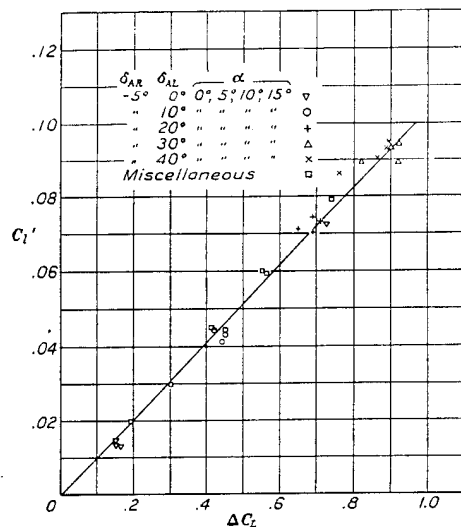

FIGURE 43.— C_l' against ΔC_L , N. A. C. A. 23012 wing with 0.20 c Clark Y external-airfoil flaps deflected as ailerons. Aileron span = $b/2$.

COMPARISON OF EXTERNAL-AIRFOIL AND ORDINARY AILERONS

	δ_A (Dif- fer- ence)	C_l'	C_d'	CF	$\frac{C_l'}{C_l}$	$\frac{CF}{CF}$
External ailerons.....	0	0.028	-0.004	0.00014	-0.15	0.0054
$C_L=1.0$	40	.079	-.015	.0024	-.19	.030
$C_L=1.7$	10	.024	-.009	.00008	-.37	.0033
	40	.071	-.023	.0014	-.32	.020
Ordinary ailerons.....	10	.039	-.009	.00012	-.23	.0031
$C_L=1.0$	40	.093	-.020	.0019	-.22	.020

Comparison of the ordinary and external-airfoil ailerons at a lift coefficient of 1.0 shows the ordinary ailerons to be somewhat worse in respect to adverse yawing moment per unit of rolling moment and superior in respect to stick force required per unit of rolling moment. At a lift coefficient of 1.7 the external-airfoil ailerons are worse than the ordinary ailerons at a lift coefficient of 1.0 in respect to adverse yawing moments and are approximately equal in respect to stick forces. In general, the external-airfoil ailerons appear to be slightly inferior at values of lift coefficient that would give comparable speeds near the minimum obtainable with the types of wing involved.

Application of results of full-span flap tests to lateral-control analysis.—The coordination of tests

of a full-span lift-increasing device with lateral control tests on semispan and quarterspan ailerons of the same type has suggested a possible method of estimating the control obtainable from similar use of other devices. The method contemplates the estimation of the control obtainable from similar use of other devices. The method contemplates the estimation of the control obtainable from similar use of other devices. The method contemplates the estimation of the control obtainable from similar use of other devices.

In accordance with the foregoing concept, representative data from the tests of the semispan ailerons have been plotted in figures 43 and 44, and data from the quarterspan aileron tests in figures 45 and 46, against values of ΔC_L and ΔC_D obtained from the lift and drag tests with ailerons neutral and flap deflected. It is apparent that a linear variation results in each case, although the scattering of the yawing-moment coefficient points indicates the possibility of a comparatively large error in estimating C_n' in individual cases. The variation may be expressed as

$$C_l' = K \Delta C_L$$

$$C_n' = K' \Delta C_D$$

where ΔC_L and ΔC_D are the differences in lift and drag coefficients of the full-span flaps produced by the assumed angular deflection at the angle of attack in question. Values of K and K' are found to vary with aileron span as shown in figure 47. No attempt has been made to establish a sign convention, since the sense of rolling and yawing moments resulting from an increase of lift or drag on a wing tip is perfectly clear. All yawing-moment coefficients shown here are adverse, resulting from the large drag increment produced by the down-going aileron.

CONCLUSIONS

1. As regards aerodynamic characteristics, the N. A. C. A. 23012 airfoil is superior to the Clark Y when they are compared either as plain airfoils or as airfoils equipped with external-airfoil flaps.
2. When external-airfoil flaps are added to the N. A. C. A. 23012 and the N. A. C. A. 23021 airfoils, the resulting improvement of the speed-range index is greater for the N. A. C. A. 23021 than for the N. A. C. A. 23012.
3. From an analysis of certain selected lateral control arrangements, it appears that usable lateral control can be obtained from external airfoils when they are deflected as full-span flaps, provided that the comparatively large values of adverse yawing moment per unit rolling moment are acceptable.

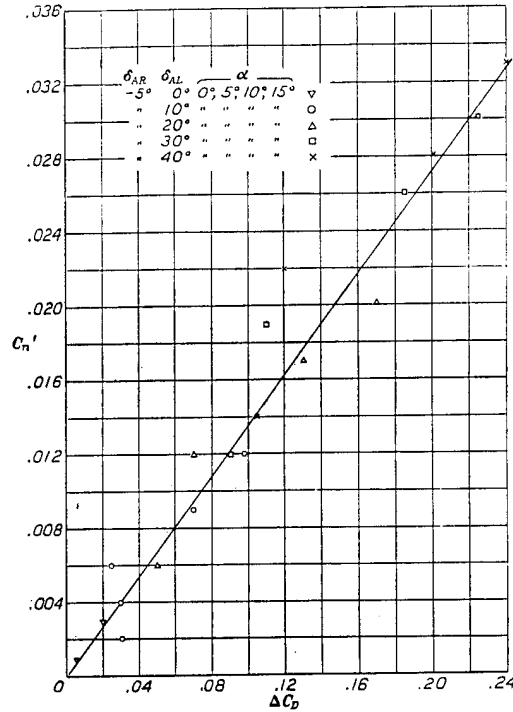

FIGURE 44.— C_n' against ΔC_D , N. A. C. A. 23012 wing with 0.20 c Clark Y external-airfoil flaps deflected as ailerons. Aileron span = $b/2$.

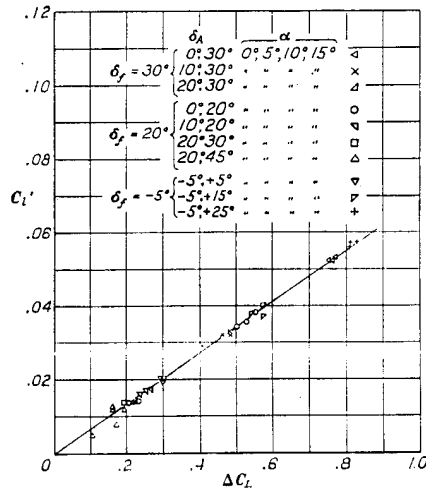

FIGURE 45.— C_l' against ΔC_D , N. A. C. A. 23012 wing with 0.20 c Clark Y external-airfoil flaps deflected as ailerons. Aileron span = $b/4$.

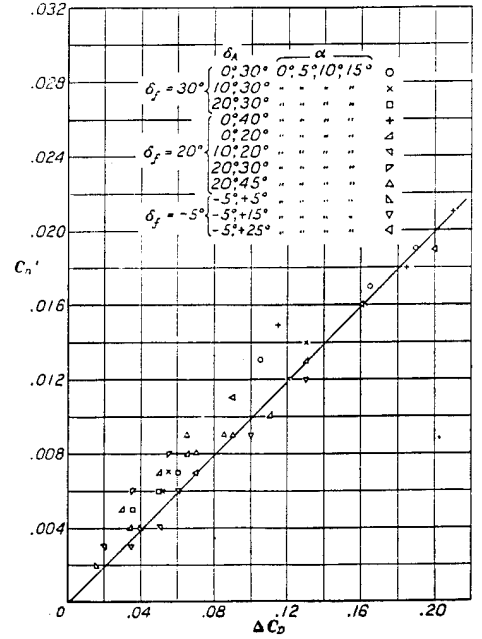

FIGURE 46.— C_n' against ΔC_D , N. A. C. A. 23012 wing with 0.20 c Clark Y external-airfoil flaps deflected as ailerons. Aileron span = $b/4$.

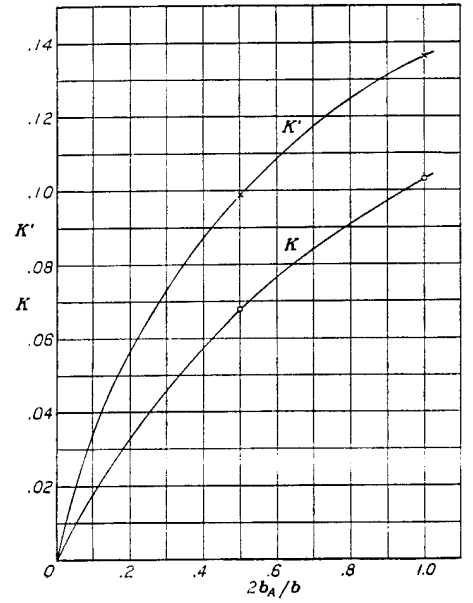

FIGURE 47.—Constants for computing rolling- and yawing-moment coefficients of ailerons from lift and drag data on full-span flaps. $C_l' = K \Delta C_L$; $C_n' = K' \Delta C_D$.

LANGLEY MEMORIAL AERONAUTICAL LABORATORY,
NATIONAL ADVISORY COMMITTEE FOR AERONAUTICS,
LANGLEY FIELD, VA., June 14, 1935.

REFERENCES

1. Weick, Fred E., and Noyes, Richard W.: Wind-Tunnel Research Comparing Lateral Control Devices, Particularly at High Angles of Attack. XIII—Auxiliary Airfoils Used as External Ailerons. T. R. No. 510, N. A. C. A., 1935.
2. Billeb, E.: Der Junkers-Doppelflügel. Luftwissen, January 1935. (Translated in The Aeroplane, March 6, 1935, pp. 269-271.)
3. LePage, W. L.: Further Experiments on Tandem Aerofoils. R. & M. No. 866, British A. R. C., 1923.
4. Bradfield, F. B., and Wood, W. E.: Wind Tunnel Tests on Junker Type Ailerons. R. & M. No. 1583, British A. R. C., 1934.
5. Platt, Robert C.: Aerodynamic Characteristics of a Wing with Fowler Flaps Including Flap Loads, Downwash, and Calculated Effect on Take-Off. T. R. No. 534, N. A. C. A., 1935.
6. Jacobs, Eastman N., and Clay, William C.: Characteristics of the N. A. C. A. 23012 Airfoil from Tests in the Full-Scale and Variable-Density Tunnels. T. R. No. 530, N. A. C. A., 1935.
7. Harris, Thomas A.: The 7 by 10 Foot Wind Tunnel of the National Advisory Committee for Aeronautics. T. R. No. 412, N. A. C. A., 1931.
8. Glauert, H.: Wind Tunnel Interference on Wings, Bodies, and Airscrews. R. & M. No. 1566, British A. R. C., 1933.
9. Weick, Fred E., and Wenzinger, Carl J.: Wind-Tunnel Research Comparing Lateral Control Devices, Particularly at High Angles of Attack. I—Ordinary Ailerons on Rectangular Wings. T. R. No. 419, N. A. C. A., 1932.

TABLE I.—COMPARISON OF VARIOUSAILERON ARRANGEMENTS

Arrangement→ Criterion ↓	Semi-span equal up-and-down from 20°	Quar-terspan equal up-and-down from 20° Flap 19°	Quar-terspan equal up-and-down from 20° Flap 30°	Quar-terspan equal up-and-down from 20° Flap 30°	Semi-span equal up-and-down from 30°	Semi-span differential from 20°	Semi-span differential from 30°	Quar-terspan differential from 30° Flap 30°	Quar-terspan differential from 20° Flap 30°	Quar-terspan differential from 10° Flap 30°	Semi-span equal up-and-down from -5°	Semi-span differential from -5°	Quar-terspan equal up-and-down from -5° Flap -5°	Quar-terspan differential from -5° Flap -5°
	1	2	3	4	5	6	7	8	9	10	11	12	13	14
C_L	1.83	1.83	1.80	1.90	1.98	1.83	1.98	1.98	1.90	1.80	1.21	1.21	1.21	1.21
C_D ($C_L=1.0$, $\delta_A=40^\circ$ difference).....	.079	.052	.074	.052	.049	.092	.072	.044	.065	.072	.094	.079	.063	.054
C_D ($C_L=1.7$, $\delta_A=40^\circ$ difference).....	.071	.044	.071	.050	.038	.092	.063	.040	.063	.069
C_F ($C_L=1.0$, $C_F=0.05$).....	.00119	.00175	.00263	.00190	.00193	.00304	-.00031	-.00035	.00019	.00030	.0009	.00100	.00129	.00154
C_F ($C_L=1.0$, $C_F=0.06$).....	-.013	-.013	-.009	-.009	-.018	-.011	-.013	-.011	-.012	-.009	-.010	-.009	-.010	-.008
C_F ($C_L=1.7$, $C_F=0.05$).....	.00085	.00164	.00069	.00120	-.00006	-.00071	-.00055	-.00002	.00019
C_F ($C_L=1.7$, $C_F=0.06$).....	-.020	-.023	-.017	-.020	-.018	-.022	-.020	-.019	-.016
Drive crank angle, degrees ($C_L=1.0$).....	11	19	13	20	20	14.5	23	34	23.5	21
Drive crank angle, degrees ($C_L=1.7$).....	12	24	14	20	14.5	27	36.2	24.5	20	9	14	15	27
Up aileron angle, degrees.....	9	1	-3	0	10	9	11	7	1	-6.5
Down aileron angle, degrees.....	31	39	23	40	50	28	41.5	43.7	31	20.5
Up aileron angle, degrees.....	8	-4	-4	0	9	8	-1.5	0	-5.5
Down aileron angle, degrees.....	32	44	24	40	28	43	45.7	32	20.0

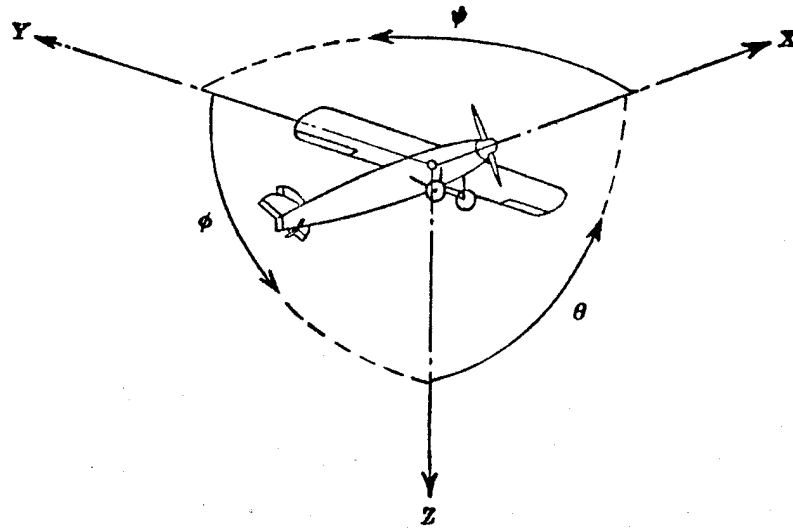

Positive directions of axes and angles (forces and moments) are shown by arrows

Axis		Force (parallel to axis) symbol	Moment about axis			Angle		Velocities	
Designation	Sym- bol		Designation	Sym- bol	Positive direction	Designa- tion	Sym- bol	Linear (compo- nent along axis)	Angular
Longitudinal.....	X	X	Rolling.....	L	Y → Z	Roll.....	φ	u	p
Lateral.....	Y	Y	Pitching.....	M	Z → X	Pitch.....	θ	v	q
Normal.....	Z	Z	Yawing.....	N	X → Y	Yaw.....	ψ	w	r

Absolute coefficients of moment

$$C_l = \frac{L}{qbS}$$

(rolling)

$$C_m = \frac{M}{qcS}$$

(pitching)

$$C_n = \frac{N}{qbS}$$

(yawing)

Angle of set of control surface (relative to neutral position), δ. (Indicate surface by proper subscript.)

4. PROPELLER SYMBOLS

D, Diameter

p, Geometric pitch

p/D, Pitch ratio

V_i, Inflow velocity

V_∞, Slipstream velocity

T, Thrust, absolute coefficient $C_T = \frac{T}{\rho n^2 D^4}$

Q, Torque, absolute coefficient $C_Q = \frac{Q}{\rho n^2 D^5}$

P, Power, absolute coefficient $C_P = \frac{P}{\rho n^3 D^5}$

C_s, Speed-power coefficient = $\sqrt{\frac{\rho V^5}{P n^2}}$

η, Efficiency

n, Revolutions per second, r.p.s.

Φ, Effective helix angle = $\tan^{-1} \left(\frac{V}{2\pi r n} \right)$

5. NUMERICAL RELATIONS

1 hp. = 76.04 kg-m/s = 550 ft-lb./sec.

1 metric horsepower = 1.0132 hp.

1 m.p.h. = 0.4470 m.p.s.

1 m.p.s. = 2.2369 m.p.h

1 lb. = 0.4536 kg.

1 kg = 2.2046 lb.

1 mi. = 1,609.35 m = 5,280 ft.

1 m = 3.2808 ft.