

**IMPACT OF PIPE LENGTH ON HORIZONTALLY PLACED INJECTION  
WELLS: A CASE STUDY ON BIOVENTING AT NAVAL AIR ENGINEERING  
STATION, LAKEHURST, NEW JERSEY.**

by

Nickolas Fidel Florez, B.S. Mining Engineering, University of Arizona, 1987

Departmental Report

Presented to the Faculty of the Environmental and  
Water Resources Engineering Program,  
Civil Engineering Department,  
University of Texas at Austin  
in Partial Fulfillment  
of the Requirements  
for the Degree of

Master of Science in Engineering

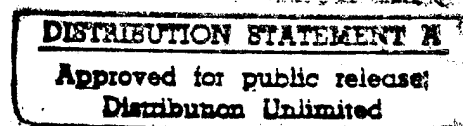

The University of Texas at Austin  
August 1995

19950913 037

DTIC QUALITY INSPECTED 5

**IMPACT OF PIPE LENGTH ON HORIZONTALLY PLACED INJECTION  
WELLS: A CASE STUDY ON BIOVENTING AT NAVAL AIR ENGINEERING  
STATION, LAKEHURST, NEW JERSEY.**

Accession For	
NTIS CRA&I	<input checked="" type="checkbox"/>
DTIC TAB	<input type="checkbox"/>
Unannounced	<input type="checkbox"/>
Justification .....	
By .....	
Distribution / .....	
Availability Codes	
Dist	Avail and/or Special
A-1	

APPROVED BY

SUPERVISORY COMMITTEE:

*Raymond C. Loehr*  
Raymond C. Loehr

*David E. Daniel*  
David E. Daniel

# TABLE OF CONTENTS

<b>LIST OF FIGURES</b> -----	<b>II</b>
<b>LIST OF TABLES</b> -----	<b>IV</b>
<b>ACKNOWLEDGEMENTS</b> -----	<b>V</b>
<b>1.0 INTRODUCTION</b> -----	<b>1</b>
<b>2.0 BIOVENTING FUNDAMENTALS</b> -----	<b>5</b>
2.1 TECHNOLOGY DESCRIPTION-----	5
2.2 CONTAMINANTS MOST SUITABLE TO BIOVENTING APPLICATIONS-----	9
2.3 IMPORTANT SITE CHARACTERISTICS-----	10
2.4 PERFORMANCE AND COST-----	13
2.5 MAJOR ADVANTAGES AND DISADVANTAGES-----	14
<b>3.0 SITE INVESTIGATIONS AND FEASIBILITY STUDIES</b> -----	<b>16</b>
3.1 1990 BENCH SCALE BIOLOGICAL TREATABILITY STUDIES-----	16
3.2 SOIL CHARACTERIZATION-----	16
3.3 FLASK STUDIES-----	17
3.4 TRAY STUDIES-----	17
3.5 DISCUSSION - 1990 TEST RESULTS-----	18
3.6 SOIL GAS PERMEABILITY TESTING-----	20
3.7 IN-SITU RESPIRATION TESTS-----	22
3.8 DISCUSSION - 1994 TESTS RESULTS-----	26
3.9 CONCLUSIONS AND RECOMMENDATIONS FOR FUTURE FEASIBILITY STUDIES-----	32
<b>4.0 SITE DESCRIPTION AND DESIGN LAYOUT</b> -----	<b>33</b>
4.1 NAEC DESCRIPTION AND HISTORY-----	33
4.2 SITE 16 CHARACTERISTICS-----	36
4.3 DESIGN LAYOUT-----	36
4.4 BIOVENTING SYSTEM OPERATION AND MONITORING-----	41
4.5 DISCUSSION - SITE CHARACTERIZATION AND SAMPLING PROTOCOL-----	46
4.5.1 Site characterization-----	46
4.5.2 Sampling protocol-----	47
4.6 DESIGN COMMENTS-----	48
4.7 DESIGN AND SAMPLING PROTOCOL CONCLUSIONS AND RECOMMENDATIONS-----	49
<b>5.0 INITIAL SOIL AND SOIL GAS SAMPLING DATA</b> -----	<b>51</b>
5.1 SOIL SAMPLING DATA-----	51
5.2 SOIL GAS DATA-----	52
5.3 CONCLUSIONS AND RECOMMENDATIONS-----	56
<b>6.0 SUMMARY CONCLUSIONS AND RECOMMENDATIONS</b> -----	<b>58</b>
6.1 FEASIBILITY STUDIES-----	58
6.2 SYSTEM DESIGN AND SAMPLING PROTOCOL-----	59
6.3 SYSTEM OPERATION AND EFFECTIVENESS-----	60
<b>APPENDIX A - IN-SITU RESPIRATION RESULTS</b> -----	<b>61</b>
<b>REFERENCES</b> -----	<b>67</b>
<b>VITA</b> -----	<b>69</b>

## LIST OF FIGURES

FIGURE 1.1 NPL SITE 16 .....	3
FIGURE 1.2 HORIZONTAL PIPING LAYOUT DIAGRAM.....	4
FIGURE 2.1 BIOVENTING INJECTION/EXTRACTION COMBINATION .....	7
FIGURE 2.1 BIOVENTING INJECTION/EXTRACTION COMBINATION .....	7
FIGURE 2.2 EFFECT OF AIR EXTRACTION RATE ON BIOREMEDIATION VERSUS VOLATILIZATION .....	7
FIGURE 2.2 EFFECT OF AIR EXTRACTION RATE ON BIOREMEDIATION VERSUS VOLATILIZATION .....	7
FIGURE 2.3 PROVIDING OXYGEN BY AIR INJECTION FOR REDUCED EMISSION OF VOLATILE COMPOUNDS	8
FIGURE 2.3 PROVIDING OXYGEN BY AIR INJECTION FOR REDUCED EMISSION OF VOLATILE COMPOUNDS	8
FIGURE 2.4 EFFECT OF AIR INJECTION RATE ON BIOREMEDIATION VERSUS VOLATILIZATION.....	8
FIGURE 2.4 EFFECT OF AIR INJECTION RATE ON BIOREMEDIATION VERSUS VOLATILIZATION.....	8
FIGURE 2.5 INITIAL SOIL MOISTURE CONTENT AT AIR FORCE BIOVENTING TEST SITES .....	11
FIGURE 2.6 COMPARATIVE COSTS OF SEVERAL CONTAMINATED SOIL REMEDIATION TECHNOLOGIES..	14
FIGURE 3.1 TOTAL PETROLEUM HYDROCARBON VS. TIME (TRAY STUDY).....	18
FIGURE 3.2 LOCATION DIAGRAM OF INJECTION WELL AND MONITORING POINTS.....	20
FIGURE 3.3 RESPIRATION RESULTS FOR BACKGROUND WELL .....	24
FIGURE 3.4 RESPIRATION RESULTS FOR MONITORING POINT 1 - 3.5.....	24
FIGURE 3.5 RESPIRATION RESULTS FOR MONITORING POINT 2 - 1.5.....	25
FIGURE 3.6 RESPIRATION RESULTS FOR MONITORING POINT 2 - 3.5.....	25
FIGURE 3.7 RESPIRATION RESULTS FOR MONITORING POINT 3 - 1.5.....	26
FIGURE 3.8 SAMPLE CALCULATION OF OXGEN UTILIZATION RATE .....	30
FIGURE 4.1 VICINITY MAP.....	34
FIGURE 4.2 NPL SITE 16.....	35
FIGURE 4.3 TPH CONCENTRATIONS (MG/KG) DRY WEIGHT .....	37
FIGURE 4.4 BIOVENTING DESIGN LAYOUT DIAGRAM .....	38
FIGURE 4.5 TYPICAL CROSSECTION OF INJECTION PIPING.....	39
FIGURE 4.6 HORIZONTAL INJECTION PIPING DIAGRAM.....	40

**FIGURE 4.7 TYPICAL MONITORING POINT CONFIGURATION .....42**  
**FIGURE 4.8 SOIL SAMPLING LOCATION PLAN NPL SITE 16.....43**  
**FIGURE 4.9 AVERAGE TPH CONCENTRATIONS AS A FUNCTION OF DEPTH.....47**

## LIST OF TABLES

TABLE 2.1	APPLICABILITY OF BIOVENTING TO ORGANIC CONTAMINENTS -----	9
TABLE 2.2	AIR PERMEABILITY(K) IN RELATION TO SOIL TYPE (DARCY)-----	10
TABLE 2.3	COMPOSITION OF THE MICROBIAL CELL-----	12
TABLE 2.4	SUMMARY OF REPORTED BIODEGRADATION RATES-----	13
TABLE 3.1	TPH REDUCTION RESULTS -----	18
TABLE 3.2	PRESSURE CHANGES DURING AIR PERMEABILITY TEST -----	21
TABLE 3.3	AIR PERMEABILITY TEST, O <sub>2</sub> AND CO <sub>2</sub> MEASUREMENTS -----	22
TABLE 3.4	CALCULATED BIODEGRADATION RATES -----	30
TABLE 4.1	SAMPLING PROTOCOL -----	45
TABLE 5.1	PRESTART-UP SOIL TPH CONCENTRATIONS-----	51
TABLE 5.2	PRESTART-UP SOIL GAS SAMPLING RESULTS-----	52
TABLE 5.3	SOIL GAS SAMPLING RESULTS AFTER ONE WEEK OF OPERATION-----	54
TABLE 5.4	OXYGEN CONCENTRATIONS AFTER 1 WEEK OF BIVENTING AND ASSOCIATED INJECTION WELL PIPE LENGTH-----	55

## ACKNOWLEDGEMENTS

There are many people who have provided support both directly and indirectly during the development of this report and throughout a rather intense year of Graduate School study that deserve formal recognition and my sincere thanks.

First, I would like to express my greatest appreciation to my best friend, closest advisor and loving wife, Virginia, who has not only suffered along with me during Graduate School, but has endured my undergraduate engineering education as well. Her patience, gentle encouragement and constant support have been instrumental during the entire educational process. My daughters, Misty and Autumn have also contributed greatly with their patience and understanding while Dad spent many hours away. They always seemed to know when I needed to spend time at school, but also knew when I needed to be reminded of what was really important.

Of course, I owe a great debt of gratitude to Dr. Raymond Loehr, my advisor. The report could not have been completed without the direction, insightful suggestions, and draft reviews that he provided. Despite a tremendous work load, he always had time to discuss any problems that developed and always had an answer for even the most difficult of circumstances. I would also like to thank Dr. David E. Daniel who served as the secondary reader and provided input that increased the overall quality of the report. I also wish to add a special thanks to Dorothy Fonteix, the on site project environmental engineer, who helped conceive of the study and provided most of the site information.

Most importantly, no acknowledgment would be complete without giving thanks to he whom all things have been made possible. In the words of Paul the Apostle, I also wish to "...give thanks always and for everything in the name of our Lord Jesus Christ to God the Father" (Ephesians 5:20).

## 1.0 INTRODUCTION

The Naval Air Engineering Center (NAEC) at Lakehurst, New Jersey is a 7,400 acre facility with the primary mission of conducting programs of research, development and engineering support for aircraft-platform interface systems. NAEC Lakehurst is an eighty year old complex that has, over the years, developed a number of environmental problems similar to that of most mini-industrial complexes. Among the sites to be remediated include several that are on the National Priority List (NPL), including Site 16, which is the test site for this report.

Site 16 is located adjacent to the former Naval Air Technical Training Center's fire fighting training area (Figure 1.1). The training area includes two unlined fire fighting pits that were commonly filled with six inches of water prior to the addition of two inches of aircraft fuel that were set on fire during training exercises. The lagoon, located within Site 16, was used to capture runoff during training exercises. Soil testing at various depths ranging from 1 to 6 feet revealed total petroleum hydrocarbon (TPH) concentrations as high as 29,000 mg/kg (dry weight). The site has been permitted for soil remediation of petroleum hydrocarbons within the vadose zone by bioventing, utilizing horizontal injection wells. At the beginning of this study (April, 1995), the piping, blower system, and monitoring wells had been installed (Figure 1.2). Commencement of system operation was awaiting final approval by the Navy and other regulatory agencies.

The dashed lines on Figure 1.2 indicate the horizontal length of injection piping to be utilized for bioventing of Site 16. A single blower located at the trailer will provide air via the delivery line (solid line perpendicular to the dashed lines) which will in turn be distributed to the slotted piping (dashed lines) for bioventing of the contaminated area. The slotted piping runs are rather lengthy and vary in size from approximately 170 feet to 300 feet in length. The NAEC project engineer expressed some concern that the longer piping runs may not receive sufficient air flow due to excessive head losses along the

slotted piping and therefore reduce the effectiveness of the air delivery system and subsequent bioremediation.

The objective of this study is to determine what impact the length of the horizontal piping runs have on the performance of the remediation effort. Secondary objectives will be to provide recommendations for corrective action if inadequate air flow is determined to be significant, evaluate the effectiveness of the remediation effort in general and finally to provide recommendations to enhance future feasibility studies and bioventing designs for similar Navy applications. System operation and sampling will be performed by the contractor who installed the system with laboratory analyses accomplished by an independent laboratory. It is noted here that the contractor is not tasked to evaluate system performance with respect to pipe length, therefore this analysis is not only independent of the contractor's data analysis, but should also be of practical use if and when the system's operation is modified. The evaluation of overall system effectiveness will be independently assessed in this report based on results of soil gas sampling provided by the independent laboratory.

It is also noted that the monitoring system, specifically the location, number, and sampling frequency of the monitoring wells, was not specifically designed for this type of analysis. However, the monitoring system as installed should allow for accomplishment of the stated objectives. Remediation of Site 16 also includes a small air-sparging system within the lagoon area. The air-sparging component is important for remediation of saturated zone soils, but otherwise is separate from the horizontal bioventing application. The air-sparging operation is not expected to have a significant impact the bioventing results, however, the design will be included in this report and any impact to the bioventing system or the remediation effort of vadose zone soils within Site 16 will be discussed.

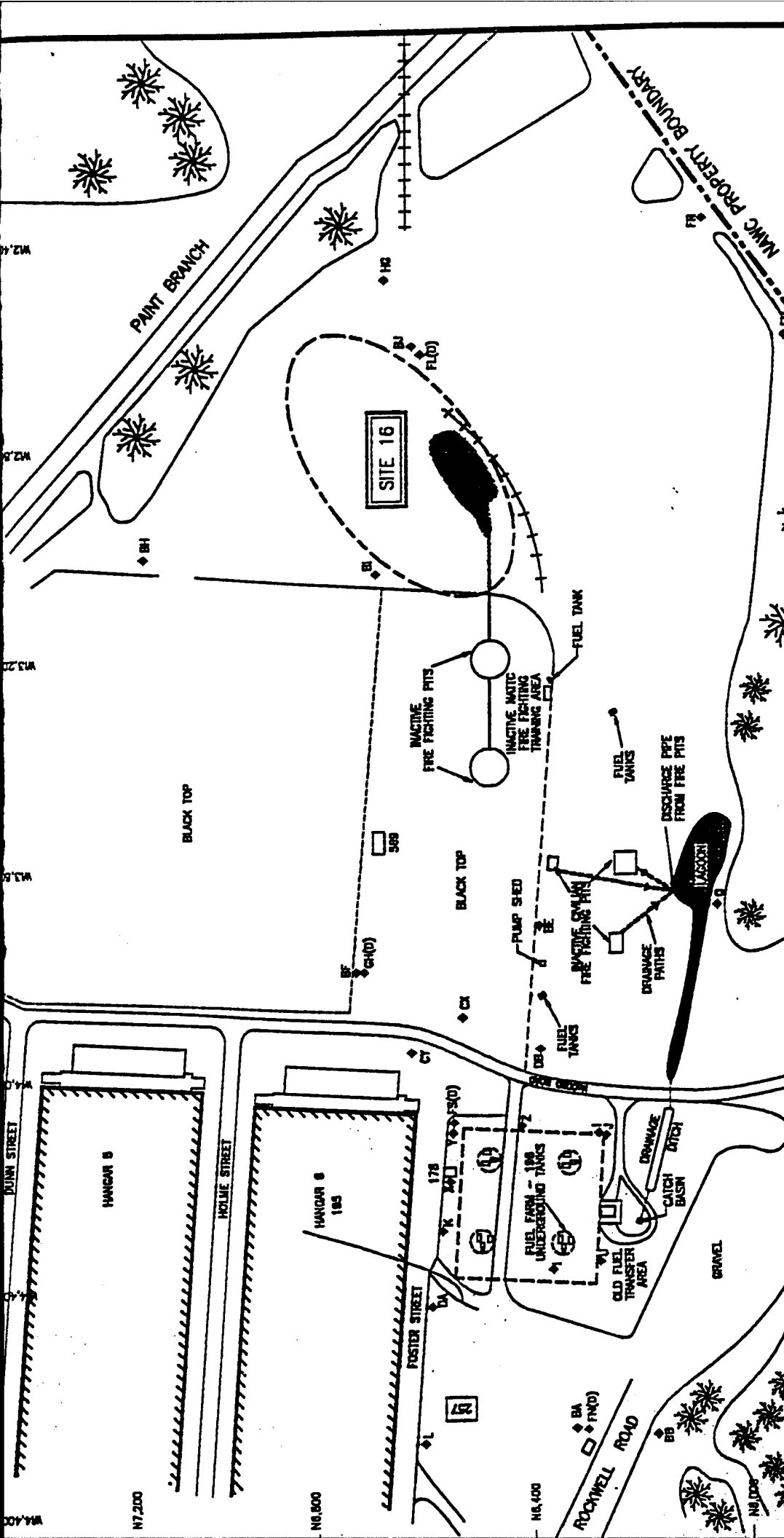

5/10/85 | PMgr: JHH | D:\JH\94432SITE | LAYER: SITE16

Figure 1.1  
NPL SITE #16

Prepared For:  
NAVAL AIR WARFARE CENTER  
AIRCRAFT DIVISION  
LAKEHURST, NEW JERSEY  
AQUATEX PROJECT No. 94432A

P.O. Box 1204  
Hammoncton, NJ  
(609) 587-8280

**Aquod-tex**

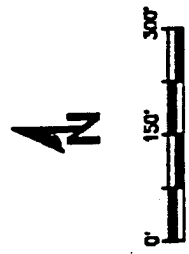

LEGEND:  
◆ BI MONITORING WELL LOCATION (D= DEEP)

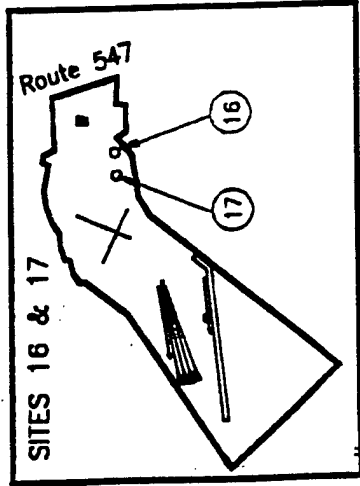

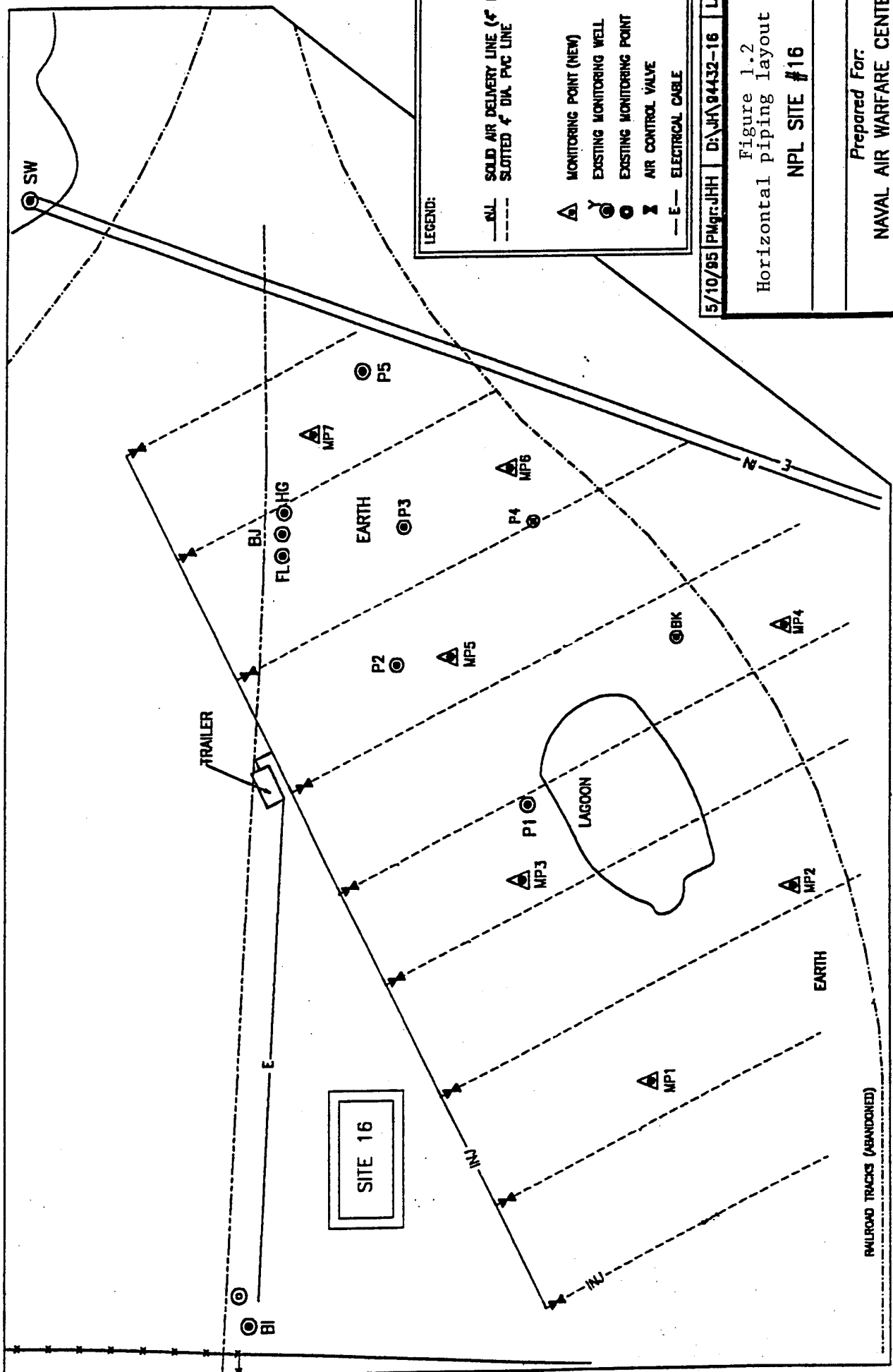

**LEGEND:**

- SOLID AIR DELIVERY LINE (4" PVC)
- - - - - SLOTTED 4" DIA. PVC LINE
- ▲ MONITORING POINT (NEW)
- EXISTING MONITORING WELL
- EXISTING MONITORING POINT
- ⊗ AIR CONTROL VALVE
- E - ELECTRICAL CABLE

5/10/95 PMgr:JHH | D:\JH\94432-16 | LAYER: 0

Figure 1.2  
Horizontal piping layout diagram

**NPL SITE #16**

Prepared For:  
**NAVAL AIR WARFARE CENTER**  
**AIRCRAFT DIVISION**  
**LAKEHURST, NEW JERSEY**  
**AQUATEX PROJECT No. 94432A**

**Aquod-tex**  
 P.O. Box 1204  
 Hammonton, NJ  
 (809) 587-8280



## **2.0 BIOVENTING FUNDAMENTALS**

Bioventing applications, as with all bioremediation processes, must fulfill several critical requirements for successful biodegradation to occur. Of primary importance are; i) the availability of microorganisms that will degrade the contaminants of concern, ii) provision of an energy source (usually carbon) and iii) availability of electron acceptors (Cookson, 1995). Also necessary are the proper environmental conditions that are conducive to microbial growth ie. soil moisture content, nutrient availability, and suitable pH and temperature conditions. Section 2.3 of this chapter (Important site characteristics) discusses these requirements in relation to bioventing applications. This chapter also provides a basic description of bioventing technology, a description of contaminants most suitable to bioventing applications, performance and cost data for typical systems, and the major advantages and disadvantages of the technology.

### ***2.1 Technology Description***

Bioventing is the process of providing the electron acceptor, oxygen in the form of air, to the vadose zone in order to enhance aerobic biodegradation of a contaminant. For most bioremediation applications, the indigenous microorganisms are adequate (Cookson, 1995) and the contaminant acts as the carbon or energy source, completing the three critical requirements for bioremediation. Bioventing is applicable to any contaminant that is aerobically biodegradable, however, some contaminants are more suitable than others (see Section 2.2). Air can be supplied either by injection wells or extraction wells, or in combination. The process is similar to soil vapor extraction (SVE) in that the process involves the transfer of air through the soil. However, the mechanism for removal of contaminants is very different. In SVE, air is pulled from the surface and through the contaminated zone utilizing extraction wells. The low pressure air stream vaporizes volatile organic compounds (VOCs) that are ultimately exhausted into the

atmosphere. Typical SVE systems require off gas treatment of VOCs prior to release into the atmosphere. In contrast, bioventing is typically accomplished by air injection at much lower air flow rates than for SVE. The intent is to provide only enough oxygen to maximize microbial activity yet minimize volatilization. While air injection systems are most common, bioventing systems can also be designed with extraction wells or a combination of injection/extraction wells. When properly designed, off-gas treatment for bioventing systems should not be required. Figures 2.1 - 2.4 show the process schematics for bioventing systems utilizing an air injection and air injection/extraction combination. As shown, extraction systems will likely always have a volatilization component, while injection only systems can be designed to maximize biodegradation and still produce minimal volatilization.

Figure 2.1 Bioventing injection/extraction combination . (Cookson, 1995).

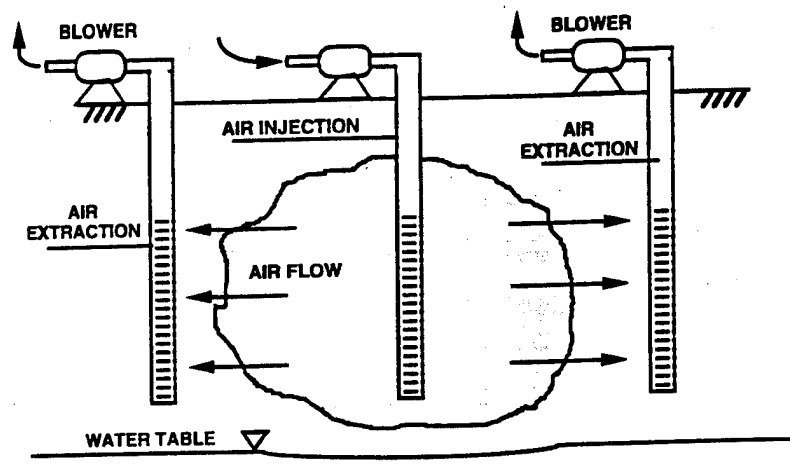
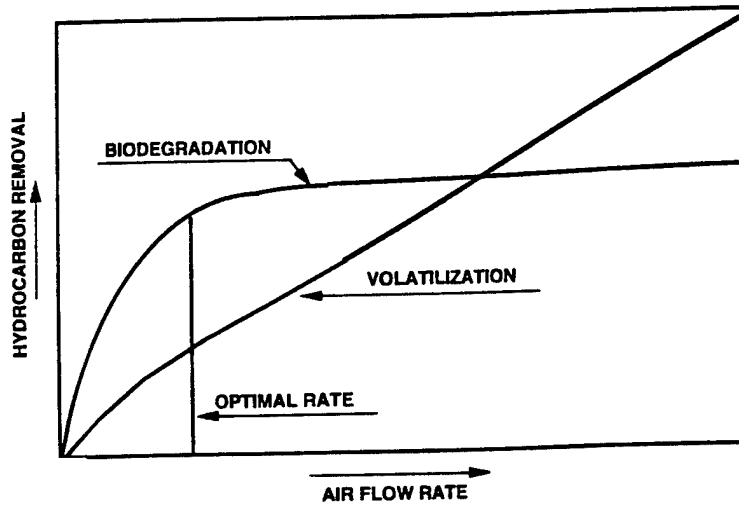
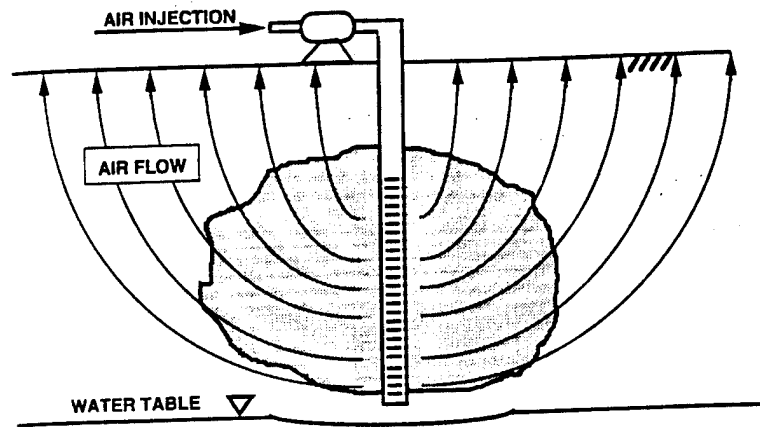

Figure 2.2 Effect of air extraction rate on bioremediation versus volatilization. (Hinchee, 1993b).



**Figure 2.3** Providing oxygen by air injection for reduced emission of volatile compounds. (Cookson, 1995).



**Figure 2.4** Effect of air injection rate on bioremediation versus volatilization. (Hinchee, 1993).

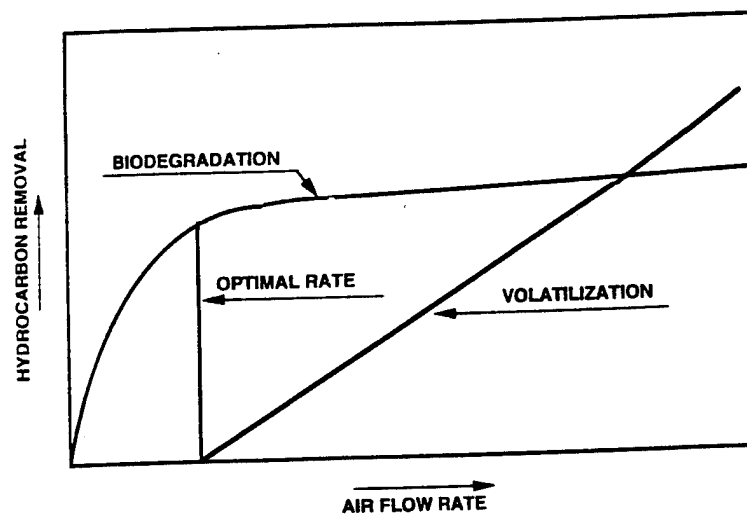

## 2.2 Contaminants most suitable to bioventing applications

To date, most bioventing applications have been to soils containing petroleum hydrocarbons (Hoeppe et al., 1991). Bioventing is also applicable to any aerobically biodegradable organic contaminant, however, those contaminants with high volatility will be more susceptible to loss by volatilization. This is particularly true when low pressure extraction wells are utilized. In general, contaminants with a vapor pressure above 760 mm Hg are gases at ambient temperatures and volatilize too rapidly to be biodegraded in a bioventing system. Contaminants with vapor pressures between 1 and 760 mm Hg are amenable to both volatilization and biodegradation including many contaminants of interest to regulatory agencies, such as benzene, toluene, and the xylenes. Contaminants below 1mm Hg cannot be removed by volatilization but can be biodegraded. Table 2.1 lists the relative suitability of remediating some of the most important contaminants of concern.

**Table 2.1 Applicability of bioventing to organic contaminants**

Rank*	Compound	Applicability**
1	Trichloroethylene	M
2	Toulene	G
3	Benzene	G
4	PCBs	P
5	Chloroform	M
6	Tetrachloroethylene	P
7	Phenol	G
8	1,1,1-Trichloroethane	M
9	Ethylbenzene	G
10	Xylene	G
11	Methylene chloride	M
12	<i>trans</i> -1,2-Dichloroethylene	M
13	Vinyl chloride	M
14	1,2-Dichloroethane	M
15	Chlorobenzene	M

SOURCE: INET, 1993

\* Rank is the USEPA listing for contaminants most frequently reported at superfund sites.

\*\* G, M, and P refer to good, moderate, and poorly suited for bioventing.

### **2.3 Important site characteristics**

Among the most important site characteristics for bioventing applications are soil gas permeability and moisture content. Of the two, soil gas permeability is likely the most important (Norris et al., 1994). Soil gas permeability can be defined as a soil's capacity for gas flow. It is a function of grain size, soil uniformity, porosity and moisture content. Typically, permeability in excess of 1 Darcy ( $1 \times 10^{-8} \text{ cm}^2$ ) is adequate for successful bioventing applications. It is noted however, that some success has been reported in low permeability soils (Downey et al., 1992). Table 2.2 illustrates the range of typical air permeability (k) values expected for different soil types.

**Table 2.2 Air permeability(k) in relation to soil type (darcy)**

Soil type	k in Darcy
Coarse sand	100 - 1000
Medium sand	1 - 100
Fine sand	0.1 - 1.0
Silts/clays	< 0.1

Source: Johnson et al., 1990

As stated above, soil moisture content also plays a key role in bioventing applications. Excessive soil moisture content hinders gas transfer for oxygen and significantly reduces aerobic activity. At 55 percent water saturation, gaseous permeability is decreased by approximately 80 percent (Cookson, 1995). Inadequate moisture content restricts bacterial activity by limiting cellular movement and metabolic reactions. A moisture content of about 15 percent by weight has been reported as

optimum for bioremediation of soil (English and Loehr, 1991). Figure 2.5 shows initial soil moisture content values found at 69 Air Force bioventing test sites located throughout the United States. As shown, most sites are within a 10% - 20% water content range, in close agreement with that considered optimum by English and Loehr (1991). It is interesting to note that many applications do have an initial water content somewhat higher than optimum, however, the venting process tends to lower the moisture content during system operation and therefore does not pose significant long term operational problems. Several test sites in semi-arid locations have sustained biodegradation rates with a moisture content as low as 3 - 5 percent by weight.

**Figure 2.5 Initial soil moisture content at Air Force bioventing test sites.**

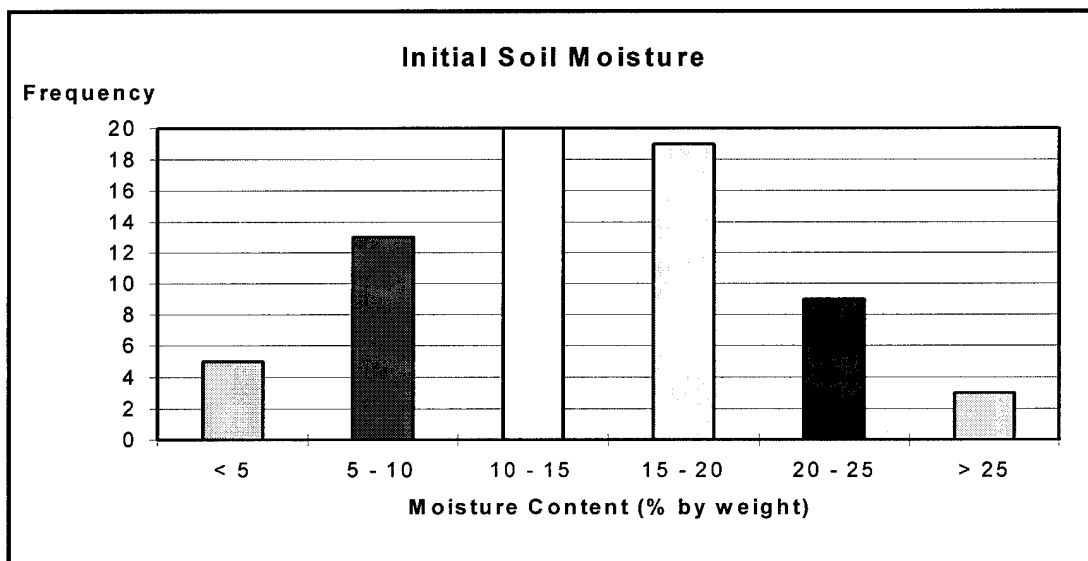

Source: AFCEE, 1994

Microorganisms require nutrients for growth and therefore nutrients must be provided in sufficient amounts if not already present. Microbial requirements for nutrients are approximately the same as the composition of their cells (Table 2.3). In

bioventing applications, carbon is generally provided by the contaminant source, hydrogen is provided by water, and air provides the oxygen source. Nitrogen and phosphorus are naturally found in soil and groundwater, but depending on contaminant concentrations, could be a limiting factor for biodegradation. At present, however, the benefits of adding nutrients for bioventing applications have yet to be demonstrated (Hinchee, 1990). Natural nutrient levels as low as 20 mg/kg total kjeldahl nitrogen (TKN) and 3 mg/kg total phosphorus have been found to be adequate to sustain biological respiration when the most limiting element, oxygen, was provided (AFCEE, 1994). The remaining elements, potassium, manganese, calcium, iron, cobalt, copper, and zinc are all provided in the form of inorganic salts and are present in adequate concentrations in most soil systems (Cookson, 1995).

**Table 2.3 Composition of the microbial cell**

Element	Percentage of dry weight
Carbon	50
Oxygen	20
Nitrogen	14
Hydrogen	8
Phosphorus	3
Sulfur	1
Potassium	1
Sodium	1
Calcium	0.5
Magnesium	0.5
Chlorine	0.5
Iron	0.2
All others	0.3

Source: Stanier et al., 1986

Soil temperature and pH also affect the microorganism's ability to conduct cellular functions. Most bacteria grow best at neutral to slightly alkaline pH. Generally, pH should be near 7 and within the range of 4 to 10. Temperature has a direct effect on the

rate of biodegradation. A rise of 10° C in temperature will approximately double the speed of reaction. Microorganisms commonly found effective in bioremediation perform over a temperature range of 10° - 40° C.

## 2.4 Performance and cost

Performance as measured by the rate of contaminant biodegradation has been reported to range from 1 - 21 mg TPH/kg soil/day. Table 2.4 provides a summary of several reported studies.

**Table 2.4 Summary of reported biodegradation rates**

Site	Scale of application	Contaminant	Estimated biodegradation rate (mg of TPH/kg of soil/day)
Hill AFB, Utah	Full scale, 2 years	JP-4 jet fuel	Up to 10 <sup>a,b</sup>
Tyndall AFB, Florida	Field pilot, 1 year	JP-4 jet fuel	2 - 20
The Netherlands	Undefined	Undefined	2 - 5 <sup>b</sup>
The Netherlands	Field pilot, 1 year	Diesel	8
Patuxent R. NAS, Md.	In-situ respiration test	JP-5 jet fuel	3
Fallon NAS, Nevada	In-situ respiration test	JP-5 jet fuel	5
Eielson AFB, Alaska	In-situ respiration test	JP-4 jet fuel	1 - 10
Kenai, Alaska	In-situ respiration test	Crude Petro	21
Tinker AFB, Oklahoma	In-situ respiration test	JP-4+others	2.7 - 18

Source: Hinchee et al., 1994

<sup>a</sup> Rates were first order with respect to oxygen; for comparison, these have been converted to zero order with respect to hydrocarbons at an assumed oxygen concentration of 10%.

<sup>b</sup> Rates were reported as oxygen consumption rates; these have been converted to hydrocarbon degradation rates assuming a 3:1 oxygen to hydrocarbon ratio.

Bioventing has been estimated to cost 65 percent less than soil vapor extraction. The treatment of 2500 yd<sup>3</sup> of petroleum contaminated soil is projected at \$47.20 per yd<sup>3</sup> compared with \$72.80 per yd<sup>3</sup> for soil vapor extraction (Hinchee, 1993b). For comparison, Figure 2.6 provides the estimated costs of several technologies commonly used to remediate fuel contaminated soils. Costs are based on the following scenarios; a) two years of in-situ bioventing, b) excavation and one year of land farming with leachate

controls, c) one year of soil vapor extraction with thermal treatment, and d) excavation followed by low-temperature thermal desorption. As indicated by Figure 2.6, bioventing is generally always less expensive than SVE and is the least expensive of the technologies described when greater than 2000 yd<sup>3</sup> are to be treated.

**Figure 2.6 Comparative costs of several contaminated soil remediation technologies.**

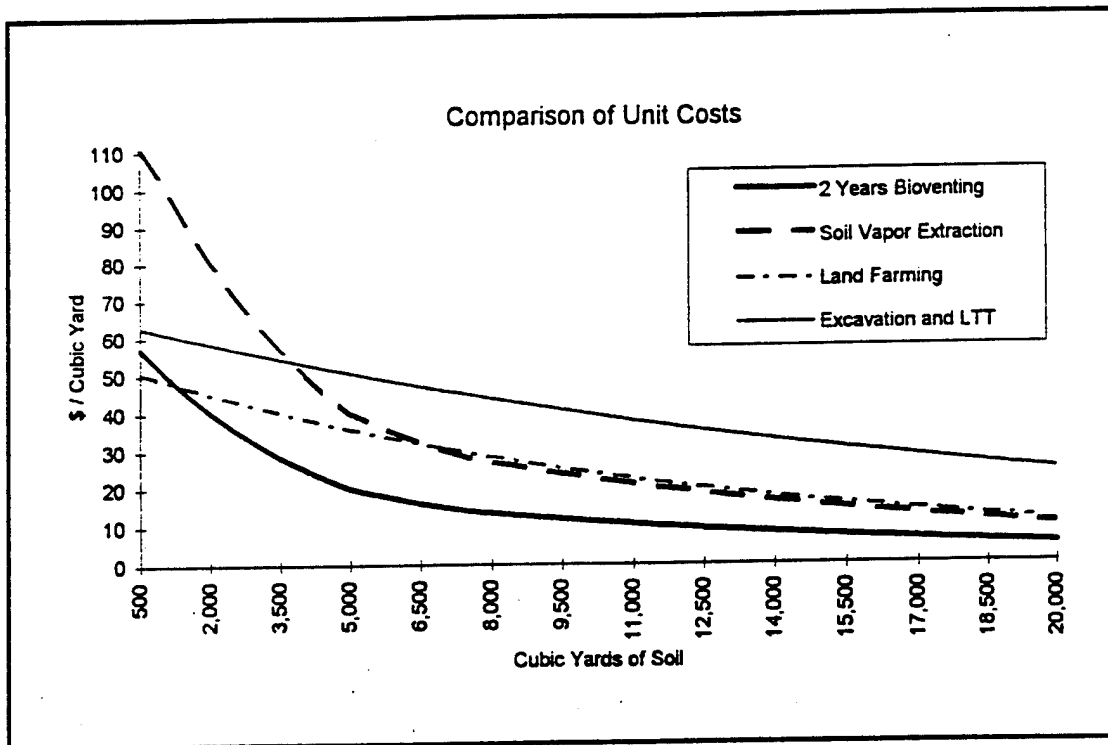

Source: AFCEE, 1994

### **2.5 Major advantages and disadvantages**

Bioventing is a relatively new technology having commonly been used, although not well understood, in combination with soil vapor extraction since the late 1980s.

Currently, however, as more is known about the technology, many more applications are

being sought that maximize biodegradation and minimize or eliminate the volatilization component. This is due primarily to the potentially significant cost savings that can be achieved compared to alternative technologies. To date, bioventing has been applied to more than 1000 sites worldwide (Norris et al., 1994). The following briefly describes the major advantages and disadvantages of bioventing technology.

#### ADVANTAGES

- ◆ Biodegradation processes (including bioventing) destroy the contaminant, not simply transfer the contaminant to another media.
- ◆ Bioventing is an in-situ process, generally with low capital and operating costs. It is particularly useful for remediation of petroleum contaminated sites.
- ◆ Bioventing can be useful for remediation of soil contamination underneath buildings or other structures.
- ◆ Bioventing is well suited for BETX reduction, therefore ideal for risk based remediations.
- ◆ Bioventing can be used exclusively or in combination with other remediation technologies such as SVE, air sparging, and bioslurping.

#### DISADVANTAGES

- ◆ Bioventing is slower than SVE, typically requiring two or more years for remediation.
- ◆ Bioventing is applicable primarily to highly permeable soils with biodegradable organic contaminants.
- ◆ Bioventing is not yet fully accepted by regulatory agencies.
- ◆ Little is known about the effectiveness of bioventing when applied to non-petroleum hydrocarbons.

### **3.0 SITE INVESTIGATIONS AND FEASIBILITY STUDIES**

Early soil sampling of Site 16 indicated average TPH concentrations of 18,000 mg/kg (dry weight). In 1990, NAEC initiated a remedial investigation to assess the possibility of landfarming as a potential remediation approach. The investigation consisted of several bench scale treatability studies. The results confirmed that landfarming was a suitable option, but recommended further study into bioventing as a potentially lower cost alternative. In 1994, NAEC initiated a bioventing feasibility study consisting of soil gas permeability and in-situ respiration tests. The following sections briefly describe the methodology and results of both the 1990 and 1994 testing, along with comments on the results and the suitability of bioventing at Site 16.

#### ***3.1 1990 bench scale biological treatability studies***

In February of 1990, biotreatability tests were carried out by Environmental Remediation, Inc. (ERI) of Baton Rouge, Louisiana. The objective of this treatability study was to assess the feasibility of bioremediation of hydrocarbon contaminated soil utilizing landfarming techniques. The work was conducted in three parts: 1) soil characterization, 2) quick (seven day) flask studies and 3) tray studies. Each is described below.

#### ***3.2 Soil characterization***

Soil collected at random from the site was separated into three batches and identified as T16A, T16B and T16C to indicate samples to be used as the control, nutrient amended and nutrient with inoculum samples respectively. The samples were initially characterized with regard to composition and physical properties. The characterization consisted of physical screening to remove over-sized debris, chemical analysis for TPH,

and determination of moisture content. The initial TPH concentrations averaged 14,800 mg/kg (dry weight) and initial moisture content averaged 8.6% by weight.

### **3.3 *Flask studies***

Seven-day flask studies were used to determine if useful indigenous microorganisms are present, and if so, whether or not they could be stimulated to mineralize the hydrocarbons, and if not, would a commercially available inoculum work? Three 2-liter flasks were used. The flasks contained 150 grams of soil plus: (1) water only; (2) water and nutrients; and (3) water, nutrients and a commercial inoculum manufactured by Microbe Masters. All flasks showed increases in microbial activity of several orders of magnitude and all reached about the same equilibrium level, including the control flask, where only water was added. The results indicated that an environment conducive to bioremediation already existed in these soils.

### **3.4 *Tray studies***

Tray studies were used to verify the flask study results and to simulate a full-scale landfarming operation. The tests were at the same conditions (water, nutrients, and nutrients + inoculum) as the flask studies described in Section 3.3. TPH analysis was conducted according to method 3550, 3630/EPA 418.1 (U.S. EPA, 1986) by an outside laboratory on samples for weeks 0 (initial characterization), 2, 5 and 7 (final characterization). The initial moisture content averaged 8.6 % by weight but was maintained between 10% and 20 % during the seven weeks by adding water as necessary. TPH values during the seven week test are presented in Table 3.1 and plotted on Figure 3.1.

**Table 3.1 TPH reduction results (tray study)**

Sample	Initial TPH (mg/kg)	Final TPH (mg/kg)	% TPH reduction
T16A	14600	5050	66
T16B	16200	2290	86
T16C	13500	2880	79

Source: Dames & Moore, 1990

A = control

B = Nutrient amended

C = Nutrient amended and inoculated

**Figure 3.1 Total petroleum hydrocarbon vs. Time (tray study)**

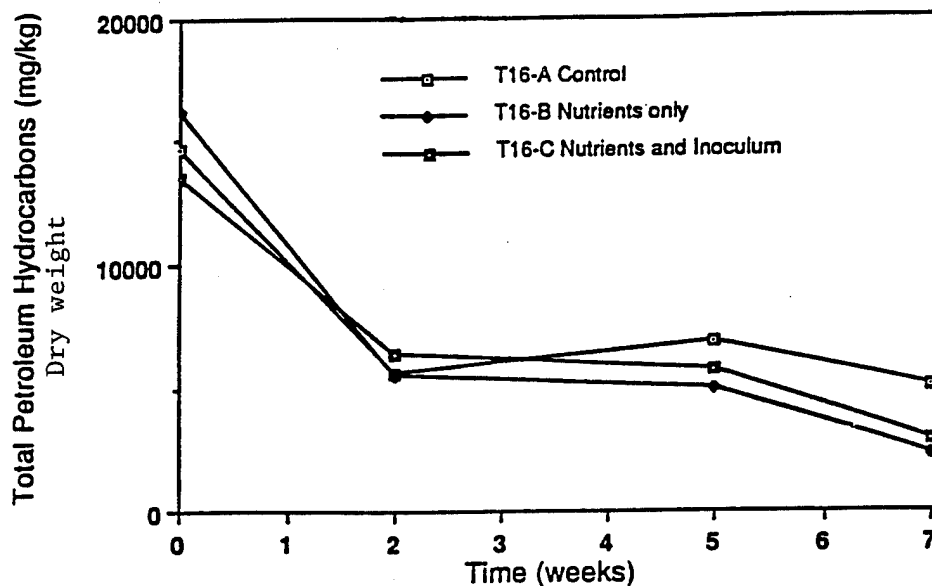

Source: Dames & Moore, 1990

Extrapolated results of the control samples showed that a reduction in TPH to a target of 100 ppm could be achieved in about 33 weeks. This period would be reduced to five months with the addition of nutrients. As with the shake flask studies, the addition of commercial inoculum had no affect, and may have actually inhibited the process.

### **3.5 Discussion - 1990 Test Results**

The initial soil moisture content, measured at an average of 8.6 %, is slightly lower than the considered optimum (15%) for bioremediation of petroleum contaminated soil. However, it is certainly within acceptable limits. During the bioventing operation, the moisture content is likely to fluctuate significantly due to an average precipitation rate of 40 inches per year in the Lakehurst area and due to the drying effect of the "venting" process. As discussed in Chapter 2, soil moisture content is of critical importance to bioventing applications. Too much moisture will decrease soil permeability and restrict air flow, while too little moisture will limit metabolic reactions. Therefore, to improve operational efficiency, consideration should be given to possible system shutdown during periods of heavy rainfall and then restarting after a couple of nonrainy days or until the moisture content reaches below 25 %. If there are months with little or no rainfall, it may also be beneficial to utilize a low tech lawn sprinkler system, particularly if the moisture content falls much below 8%.

The measured TPH reduction is encouraging from a qualitative sense, in that significant biodegradation was realized and that use of indigenous microorganisms seemed sufficient. However, quantitative biodegradation rates calculated from the tray studies cannot be directly applied to what might be expected in a bioventing application. The flask studies clearly showed that indigenous microorganisms were present, could be readily stimulated and will degrade hydrocarbons present in the soil.

Although the 1990 test work was oriented around determining the feasibility of landfarming, the results indicated that in-situ bioremediation could be a preferred alternative, due to potentially lower costs. The estimated volume of contaminated soil is

approximately 9040 yd<sup>3</sup>, therefore, a cost comparison with other soil remediation technologies, as shown in Figure 2.6, suggested bioventing as a possible lowest cost alternative. A feasibility study was therefore recommended, and in 1994, initiated. The study consisted of soil gas permeability and in-situ respiration tests.

### 3.6 Soil gas permeability testing

One horizontal injection well was installed at Site 16 (Figure 3.2). The well was constructed using a 5 foot length of 2" PVC well screen placed in a 4 foot deep trench. The well screen was connected by an elbow to a 2" PVC pipe extending above grade level. The surface soil above the well screen was then backfilled and compacted. Three monitoring boreholes were installed using hand augering at distances of 5, 10 and 20 feet

**Figure 3.2 Location diagram of injection well and monitoring points**

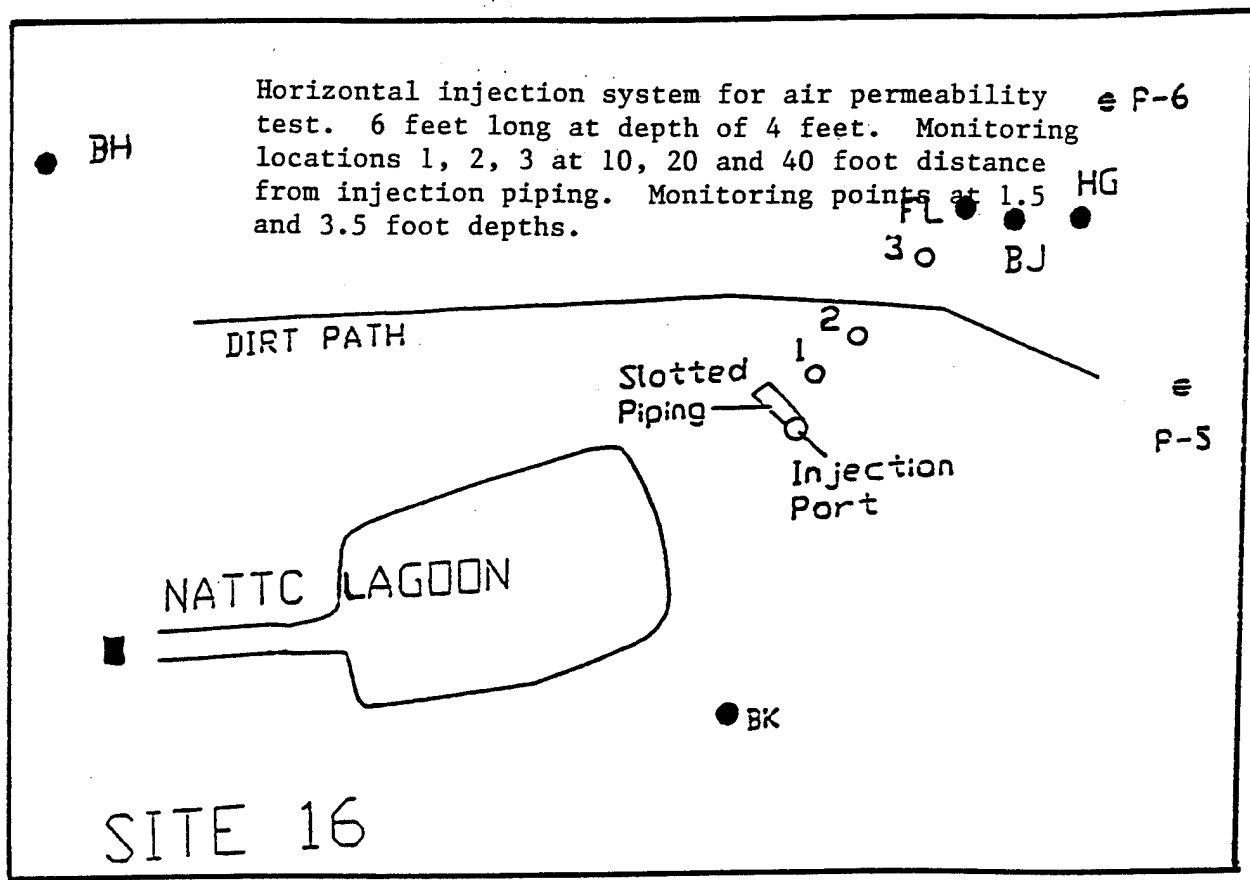

Source: Aguliar Consultants & Associates Inc., 1994

from the injection well. The borehole depths were 4 feet and each borehole contained two monitoring points, installed at 3.5 and 1.5 feet below grade. Thermocouples were installed at the deepest and shallowest monitoring point in the monitoring point borehole closest to the injection wells.

The soil gas permeability test was performed using a blower rated at 100 cfm for air injection. Air was injected into the formation at a measured rate with pressure changes measured in the adjacent monitoring points. O<sub>2</sub> and CO<sub>2</sub> measurements were made prior to the test (background) and throughout the test.

Pressures observed during the air permeability test are shown in Table 3.2. Since essentially no changes in pressure were observed after 1 minute of air injection, the data has not been graphed. CO<sub>2</sub> and O<sub>2</sub> measurements before and after these tests are shown in Table 3.3. Actual calculation of air permeability is discussed in Section 3.8.

**Table 3.2 Pressure changes during air permeability test**

Monitoring point	1 - 3.5	1 - 1.5	2 - 3.5	2 - 1.5	3 - 3.5
Distance from vent wall (ft)	9.9	9.9	19.7	19.7	39.3
Elapsed time (min)	Pressure, inches of H <sub>2</sub> O above ambient				
0	0	0	0	0	0
1	0.40	0.3	0.05	0.03	0
2	0.45	0.3	0.05	0.03	0
3	0.45	0.3	0.04	0.03	0
4	0.45	0.3	0.04	0.03	0
5	0.45	0.3	0.04	0.03	0
6	0.45	0.3	0.04	0.02	0
7	0.45	0.3	0.04	0.02	0
8	0.45	0.3	0.03	0.02	0
9	0.45	0.3	0.03	0.02	0
10	0.45	0.3	0.03	0.02	0
20	0.45	0.3	0.03	0.02	0
30	0.50	0.3	0.03	0.03	0
40	0.45	0.3	0.03	0.03	0
50	0.50	0.3	0.04	0.03	0
62	0.50	0.3	0.03	0.03	0

Source: Aguilar Associates & Consultants, Inc., 1994

**Table 3.3 Air permeability test, O<sub>2</sub> and CO<sub>2</sub> measurements**

Monitoring Point	Pre test		Post test	
	CO <sub>2</sub> (%)	O <sub>2</sub> (%)	CO <sub>2</sub> (%)	O <sub>2</sub> (%)
1 - 3.5	9.7	4.0	4.0	18.8
1 - 1.5	1.7	18.6	0.5	20.9
2 - 3.5	4.0	16.3	3.9	18.1
2 - 1.5	2.5	17.9	2.5	18.6
3 - 3.5	3.7	16.3	3.6	17.6
3 - 1.5	6.9	12.1	6.8	13.8

Source: Aguilar Associates & Consultants, Inc., 1994

### **3.7 In-situ respiration tests**

Air with a 1% to 2% helium content was injected into the 4 monitoring points for a minimum of 24 hours. The monitoring points used at each site for injection were selected based on high CO<sub>2</sub> and low O<sub>2</sub> values with the goal of obtaining a wide spatial distribution. This was followed by monitoring the changes in O<sub>2</sub>, CO<sub>2</sub> and helium concentrations and temperature in those monitoring points for 120 hours. Prior to air injection, O<sub>2</sub> and CO<sub>2</sub> concentrations were measured in all the monitoring points.

The air and helium flows were combined in a manifold with outlets connected to the 4 monitoring points. The helium concentration in the air/helium mixture was measured prior to the start of the injection process. At the end of the air/helium injection period, the system was disconnected and measurements of the O<sub>2</sub>, CO<sub>2</sub> and helium content was conducted at the 4 monitoring points. These measurements were made at approximately 1/2 hour, 1 hour, 4 hours, 6 hours, and 9 hours, after the air/helium injection was stopped and then every 6 hours. The total duration of the measurement

program was 120 hours. In some cases, it was apparent after 48 hours that concentration changes were occurring slowly and the measurement schedule was changed to every 8 hours. The actual time of measurement was recorded to the nearest minute. All concentration readings reported have been adjusted using the instrument calibration curves developed each day. Air/helium injection into the background well was done separately because of the distance between the background wells and their corresponding sites. Results are presented in Figures 3.3 to 3.7. Appendix A contains the tabularized data.

Figure 3.3 Respiration results for background well

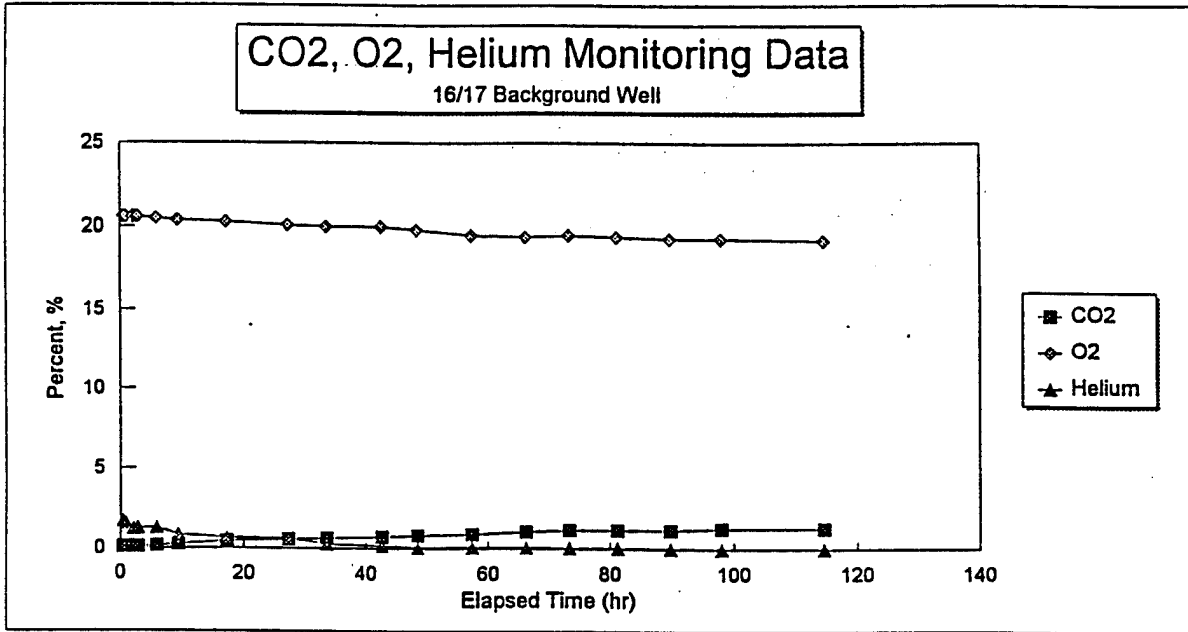

Figure 3.4 Respiration results for monitoring point 1 - 3.5

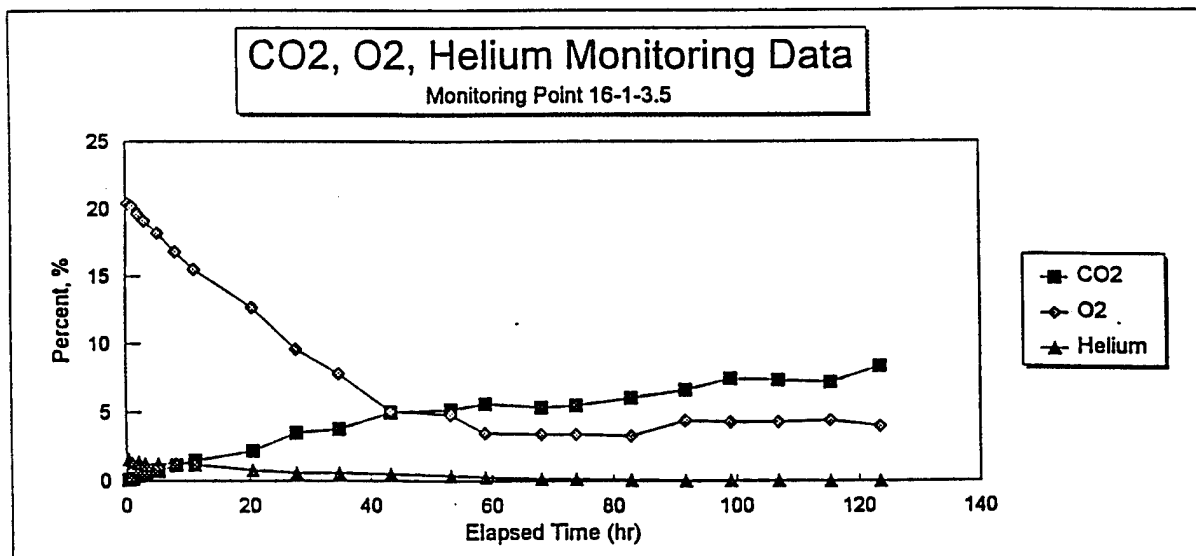

Figure 3.5 Respiration results for monitoring point 2 - 1.5

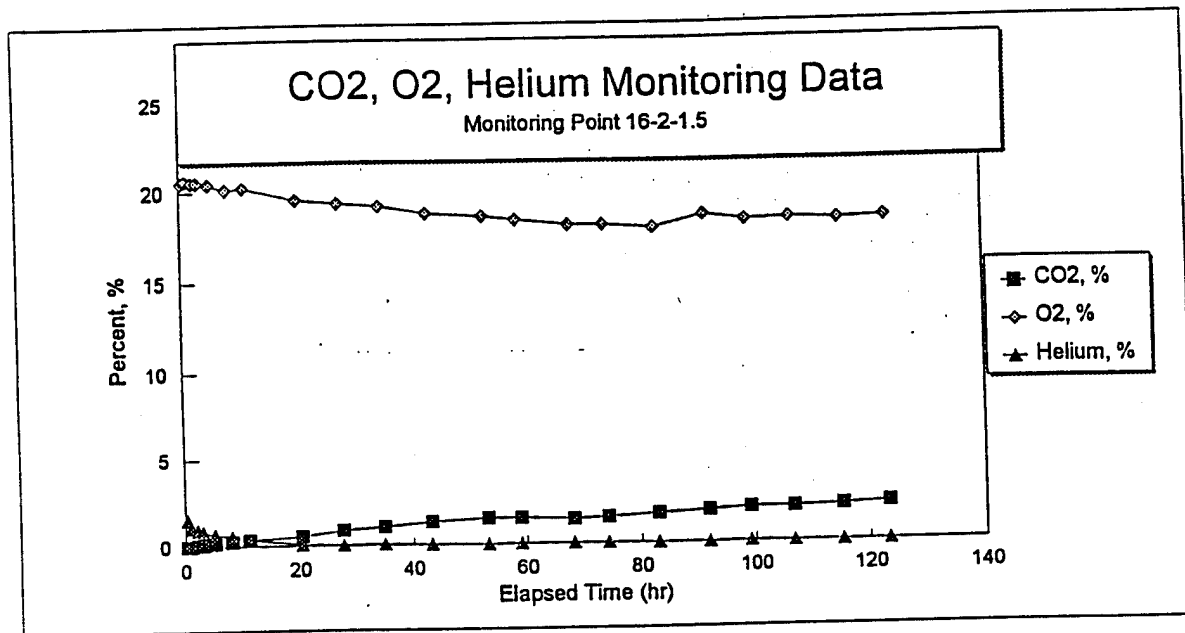

Figure 3.6 Respiration results for monitoring point 2 - 3.5

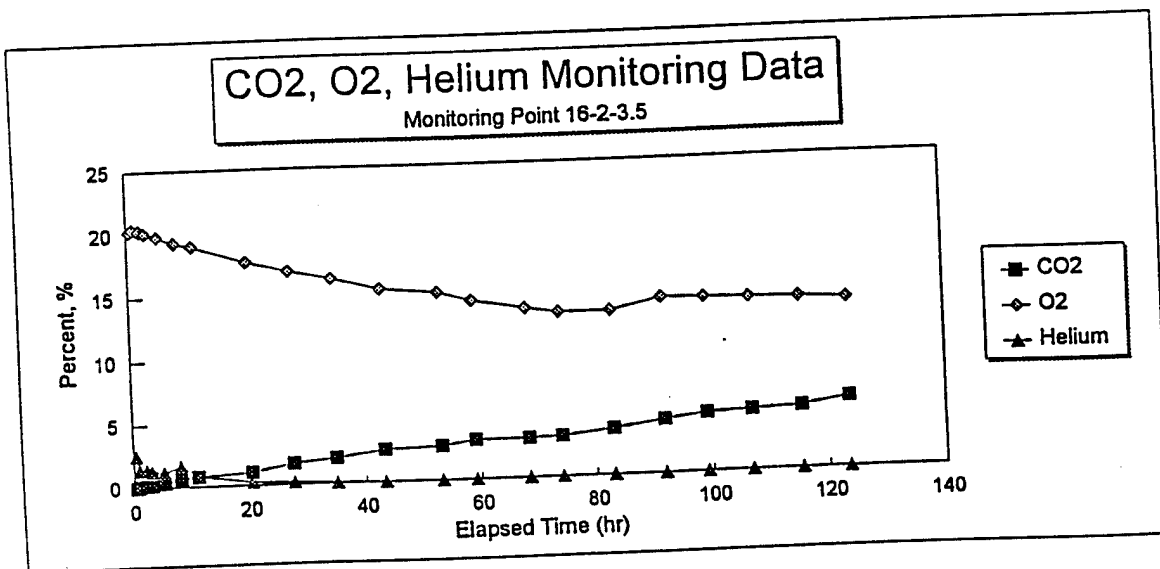
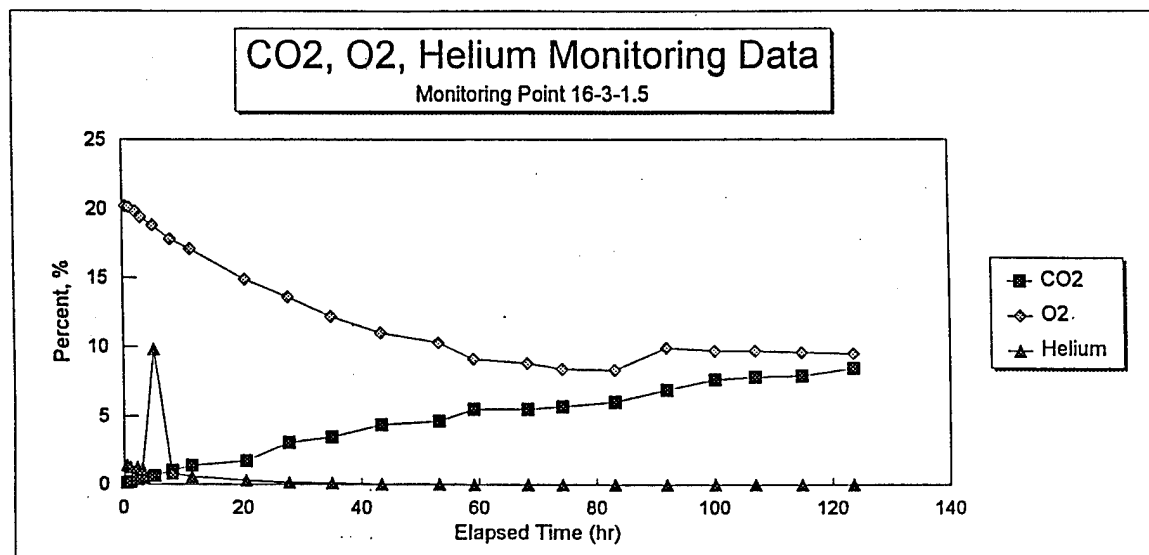

Figure 3.7 Respiration results for monitoring point 3 - 1.5



Source: Aguliar Consultants & Associates Inc., 1994

### 3.8 Discussion - 1994 Tests Results

The respiration results shown on Figures 3.3 - 3.7 provide a strong indication that biodegradation is indeed occurring. This is most obvious by comparing the uncontaminated background well, shown in Figure 3.3, with the monitoring well shown in Figure 3.4. The background well showed very little O<sub>2</sub> utilization or CO<sub>2</sub> production, however the opposite was true for the monitoring well. Oxygen utilization rates from jet fuel contaminated sites of between 0.05 to 1.0 % O<sub>2</sub>/hour, and significantly greater than background, demonstrate sufficient evidence that some microbial activity is occurring and that the addition of O<sub>2</sub> will enhance biodegradation (Hinchey et al., 1992). Calculated biodegradation rates are discussed next.

Both the air permeability and the in-situ respiration tests were conducted closely following the standard protocol developed by the Air Force. The final report presented by Aguliar Associates & Consultants, Inc. (1994), did not provide an interpretation of the data or make any recommendations. However, the data can be interpreted in the following manner using readily available sources of information.

Using the EPA's recommended method for steady-state conditions (Johnson et al., 1990), soil gas permeability (k), can be estimated by the following equation:

$$k = \frac{Q\mu \text{Ln}(R_w/R_I)}{H\pi P_w [1 - (P_{\text{atm}}/P_w)^2]} \quad (1)$$

Where:

\*Q = Volumetric flow rate from the vent well (cm<sup>3</sup>/s) = 4.72 x 10<sup>4</sup> cm<sup>3</sup>/s

μ = Viscosity of air = 1.8 x 10<sup>-4</sup> g/cm-s

R<sub>w</sub> = radius of the vent well = 2.54 cm

R<sub>I</sub> = Maximum radius of influence at steady state = 304.8 cm

H = Depth of screen = 121.9 cm

\*P<sub>w</sub> = Absolute pressure at the vent well = 8.16 x 10<sup>5</sup> g/cm-s<sup>2</sup>

P<sub>atm</sub> = ambient pressure = 1.013 x 10<sup>6</sup> g/cm-s<sup>2</sup>

\* These parameters were estimated based on maximum blower capacity.

By calculation then;

$$k = \frac{(4.72 \times 10^4)(1.8 \times 10^{-4}) \text{Ln}(2.54/304.8)}{(121.9)(3.14)(8.16 \times 10^5) [1 - (1.013 \times 10^6 / 8.16 \times 10^5)^2]}$$

$$= 2.4 \times 10^{-7} \text{ cm}^2 \text{ or } 24 \text{ Darcy}$$

Based on Table 2.2, an air permeability of 24 Darcy is typical for medium grained sandy soils, which is descriptive of the soil at Site 16. This calculation also confirms that the air permeability at the Site is suitable for bioventing applications. During future air permeability tests, actual measurement of pressure and air flow rates within the vent well is recommended to allow more precise determination of soil gas permeability.

Table 3.2 indicates that the radius of influence, identified as the distance from the vent well to the point that a measurable increase in pressure can be obtained, was slightly beyond the location of the second monitoring point of 19.7 feet. The design of the bioventing system, to be described in more detail in the next section, uses a 30 foot radius of influence (assumed by placement of horizontal injection wells approximately 60 feet apart). However, the radius of the vent well is also double in size as compared to that used during the permeability testing. Inspection of Equation 1 shows that a simple way to increase the radius of influence would be to increase the radius of the vent well by the same factor. By doubling the vent well radius, the radius of influence would then be 40 feet (2 X 20) and therefore placement of wells 60 feet apart would be appropriate with a small factor of safety.

Small concentrations of helium (1% - 2%) are typically included in soil respiration tests as an inert tracer gas to assess the extent of diffusion of soil gases within the aerated zone. A rapid drop in helium concentration indicates possible short-circuiting at that specific monitoring point (Hinchee et al., 1992). A rule of thumb, suggested by Hinchee (1992), is a fractional loss of no greater than 40% is acceptable over a 100 hour period. In this case, three of the four monitoring points experienced a 100% loss of helium within a 100 hour period. This result is likely due to improper well installation by failing to adequately seal the well. It is evident from the obvious decreases in O<sub>2</sub> and coinciding increases in CO<sub>2</sub>, that biodegradation was occurring. However, the apparent leakage of helium prevents determination of biodegradation rates with a high level of

confidence and the calculated biodegradation rates must be taken with some skepticism for accuracy.

With concerns about the soil respiration noted, a biodegradation rate can be estimated with the data provided. This is done by using the stoichiometric relationship below for oxidation of hexane as the representative hydrocarbon.

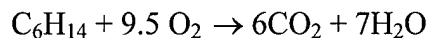

The biodegradation rate in terms of mg of hexane-equivalent per kg of soil can be estimated using the following equation:

$$K_B = K_0 A D_0 C / 100 \quad (2)$$

Where:

$K_B$  = Biodegradation rate (mg/kg-day)

$K_0$  = Oxygen utilization rate (%/day)

$A$  = Volume of air/kg of soil (l/kg)

$D_0$  = density of oxygen gas (mg/l)

$C$  = mass ratio of hydrocarbon to oxygen required for mineralization

Using assumptions of porosity = 0.3, soil density of  $1,440 \text{ kg/m}^3$ ,  $D_0 = 1,330 \text{ mg/l}$  and a hydrocarbon to oxygen ratio of 1:3.5 based on the stoichiometric relationship described above, the resulting biodegradation rate as a function of the oxygen utilization rate becomes:

$$K_B = 0.8 K_0 \quad (3)$$

Using Equation 3, the calculated biodegradation rates for the four monitoring points is shown on Table 3.4.

**Table 3.4 Calculated biodegradation rates**

Monitoring point	O <sub>2</sub> utilization rate(% O <sub>2</sub> /hr)	K <sub>0</sub> (%/day)	K <sub>B</sub> (mg/kg/day)
1 - 3.5	0.359	8.62	6.89
2 - 1.5	0.036	0.86	0.69
2 - 3.5	0.101	2.42	1.94
3 - 1.5	0.157	3.77	3.01

The O<sub>2</sub> utilization rates shown in Figure 3.8 were calculated from the tabulated data in Appendix A. The utilization rate was determined by plotting the O<sub>2</sub> utilization rate versus time and then calculating the slope of a best fit line (% O<sub>2</sub>/hr). K<sub>0</sub> was obtained by multiplying the utilization rate by 24 hr/day. K<sub>B</sub> was then obtained by use of Equation 3. An example is provided in Figure 3.8.

Figure 3.8 Sample calculation of oxygen utilization rate.

Monitoring point 1 - 3.5	
Time (hours)	% O <sub>2</sub> /hr utilized
0.3	20.4
1	20.2
2	19.6
3	19.1
5.1	18.2
8.1	16.8
11.1	15.5
20.4	12.7
27.6	9.6
34.7	7.8
43.3	5.1

slope = -0.359

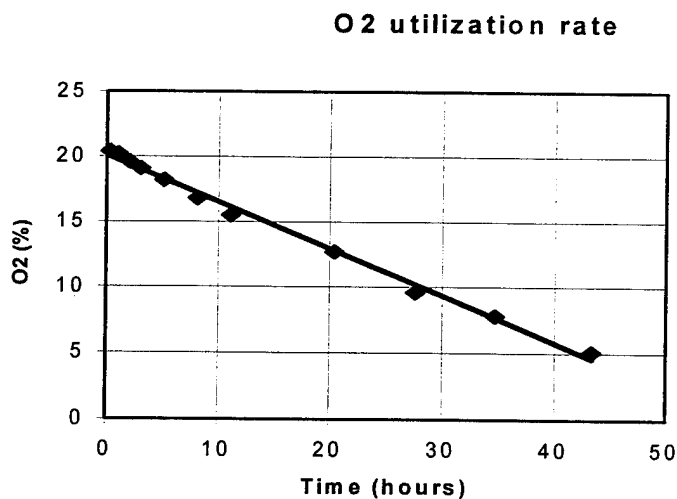

The following equations indicate how the oxygen utilization rate (K<sub>0</sub>) and the biodegradation rate (K<sub>B</sub>) can be calculated using the slope of 0.359 obtained from the sample data shown in Figure 3.8.

$$K_0 = 0.359 \% O_2/hr \times 24 \text{ hr/day} = 8.62 \% O_2/day$$
$$K_B = 0.8 K_0 = 0.8 \times 8.64 \% O_2/day = 6.89 \text{ mg/kg/day}$$

Biodegradation rates can vary considerably depending on actual site conditions. For comparison, the biodegradation rate at 61 different Air Force sites ranged from less than 0.82 to more than 24.66 mg/kg/day, dry weight (AFCEE, 1994). The calculated biodegradation rate for Site 16 fell well within this range except for monitoring point 2 - 1.5. Hinchee and Ong (1992) have reported O<sub>2</sub> utilization rates measured from active treatment areas to be nearly identical to those measured by in-situ respiration tests.

It is noted that the oxygen concentrations taken from soil gas measurements prior to the air permeability test (Table 3.3) were generally high enough to be considered nonlimiting, and therefore natural attenuation should have been considered as a possible preferred alternative. Hinchee states that oxygen concentrations above 5 % indicate that microbial activity is not oxygen limited (Hinchee et al., 1992). A soil gas survey would help provide the information necessary to make this determination. This survey would also be beneficial in determining the areal extent of the contamination and aid in the design of a bioventing system, if selected as the treatment method.

It is also noted that only four of the six installed monitoring points for the air permeability test were actually monitored. The selection of the four was based on the monitoring points with the highest CO<sub>2</sub> and lowest O<sub>2</sub> concentrations found during the pre test. This procedure is unfortunate due to the loss of easily obtained data from the already installed, but unmonitored, points.

### ***3.9 Conclusions and recommendations for future feasibility studies***

The in-situ respiration tests showed a rapid drop in helium concentrations at all monitoring points, indicating possible short circuiting due to improper monitoring point installation. It is therefore recommended that a performance requirement be included in future contracts to indicate that a fractional loss of helium concentration cannot exceed 40% of in a 100 hour period.

Measurements of vent well air flow and pressure were not included during the air permeability tests, requiring these parameters to be estimated. It is recommended that these measurements be included as part of the contract requirements for air permeability tests to allow more accurate calculation of soil permeability.

During the in-situ respiration tests, only four of the six installed monitoring points were utilized during data collection. It is recommended that all installed monitoring points be utilized during data collection.

Natural attenuation was never eliminated as a possible preferred alternative. The air permeability tests gave no indication that oxygen was indeed limiting and therefore further investigation was warranted. It is therefore recommended that a soil gas survey be included as part of future bioventing feasibility studies. A soil gas survey will show if natural attenuation is a possible alternative, will assist in defining the extent of contamination and will aid in bioventing system design, should bioventing be necessary.

## **4.0 SITE DESCRIPTION AND DESIGN LAYOUT**

This section provides a detailed description of the NAEC area and history, Site 16 characteristics, and the bioventing system design and monitoring plan.

### ***4.1 NAEC description and history***

NAEC is located in Jackson and Manchester Townships, Ocean County, New Jersey, approximately 14 miles inland from the Atlantic Ocean. NAEC encompasses approximately 7,400 acres and is bordered by Route 547 to the east, Fort Dix Military Reservation to the west, woodland to the north, and the town of Lakehurst and woodland to the south (Figure 4.1). The boundaries of the base loosely resemble the stock of a shotgun. NAEC and the surrounding area are located within the Pinelands National Reserve, the most extensive undeveloped land tract of the Mid-Atlantic Seaboard. The climate is hot and humid in the summer and cool in the winter with temperature ranges of 72° - 92° F and 22° - 46° F, respectively. Annual precipitation averages 40 inches per year. Surface elevations at NAEC range from a low of approximately 60 feet above mean sea level in the east central part of the base, to a high of approximately 190 feet above mean sea level in the southwestern part of the base. Surface slopes are generally less than five percent.

The history of the base dates back to 1916, when the Eddystone Chemical Company leased the property from the Manchester Land Development Company to develop an experimental firing range for the testing of chemical artillery shells. In 1919, the U.S. Army assumed control of the site and named it Camp Kendrick. Camp Kendrick was turned over to the Navy and formally commissioned Naval Air Station (NAS) Lakehurst, New Jersey on June 28, 1921. The Naval Air Engineering Center (NAEC) was moved from the Naval Base, Philadelphia to Lakehurst in December 1974. At that time, NAEC became the host activity, thus, the new name NAEC.

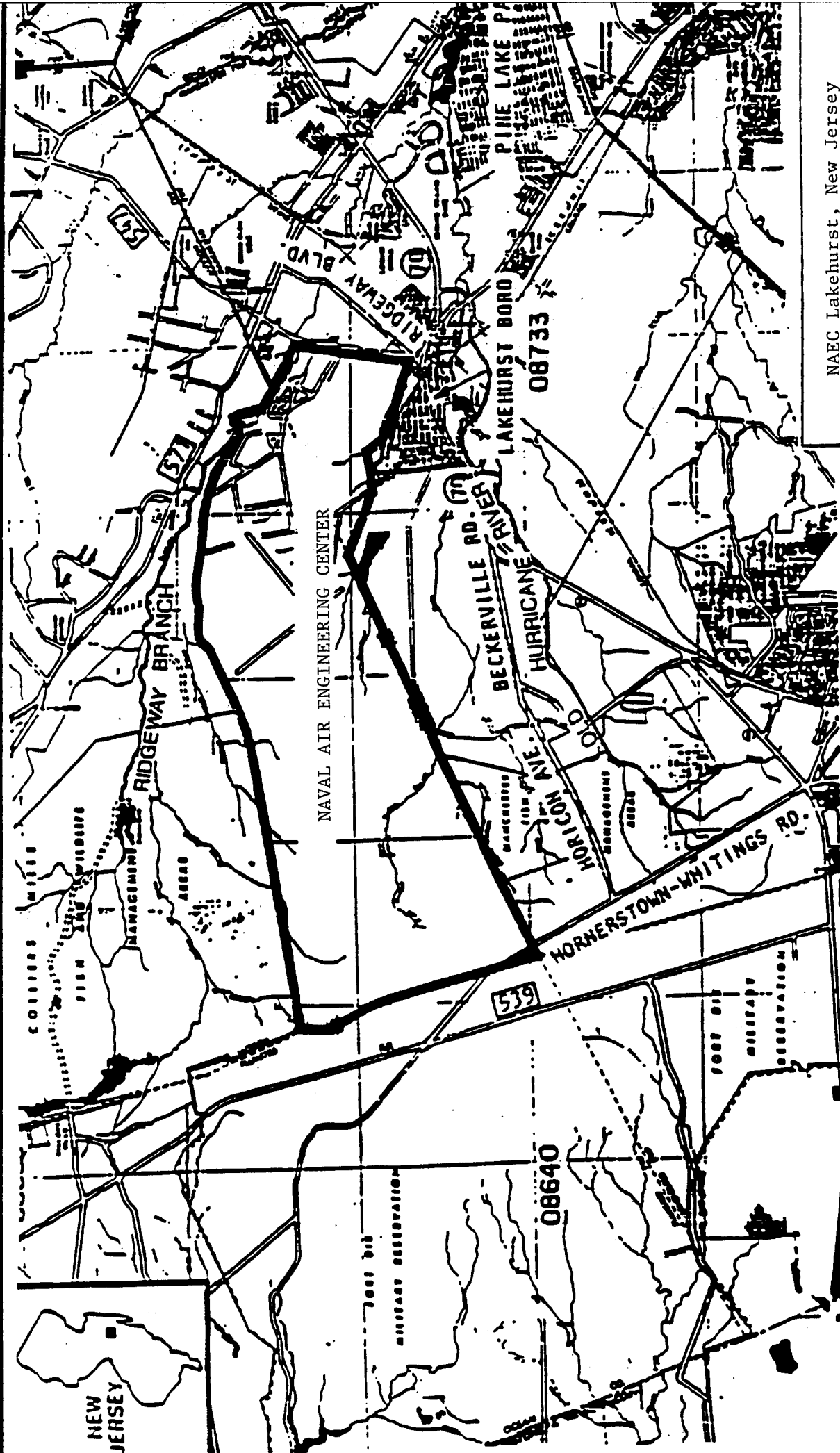

NAEC Lakehurst, New Jersey

Figure 4.1 Vicinity map



REFERENCE:  
 HAGSTROM MAP OF  
 OCEAN COUNTY, NEW JERSEY



## **4.2 Site 16 characteristics**

Site 16 is located adjacent to two abandoned fire fighting training pits (Figure 4.2). The unlined fire fighting pits were commonly filled with six inches of water prior to the addition of two inches of aircraft fuel, which were set on fire during training exercises. The lagoon, located within Site 16, was used to capture runoff during training exercises. Fire fighting training is no longer conducted at the site and the lagoon is normally dry, except immediately after a rain shower.

The contamination at Site 16 forms roughly a triangular shaped area with a length of about 400 feet along the longest axis and a maximum width of about 245 feet perpendicular to the long axis (Figure 4.3). The depth of the vadose zone is approximately 5 feet, for an estimated volume of 9042 yd<sup>3</sup> of contaminated soil within the vadose zone. Soil sampling at various depths, ranging from 1 to 6 feet, showed a wide variation in TPH concentrations ranging from 0 to 29,000 mg/kg dry weight (Figure 4.3).

## **4.3 Design Layout**

The bioventing system design has been configured with horizontal piping, due to a very shallow water table at approximately 5 feet. A 500 foot long, solid 4 inch diameter PVC air supply line has been installed parallel to the long axis of the contaminated zone and functions as the main air distribution line. A set of nine, 4 inch diameter, slotted PVC air injection lines are connected perpendicular to the main air distribution line. The air injection lines vary in length from about 160 feet at both ends of the system to approximately 300 feet at the center (Figure 4.4). The air injection lines are spaced at 60



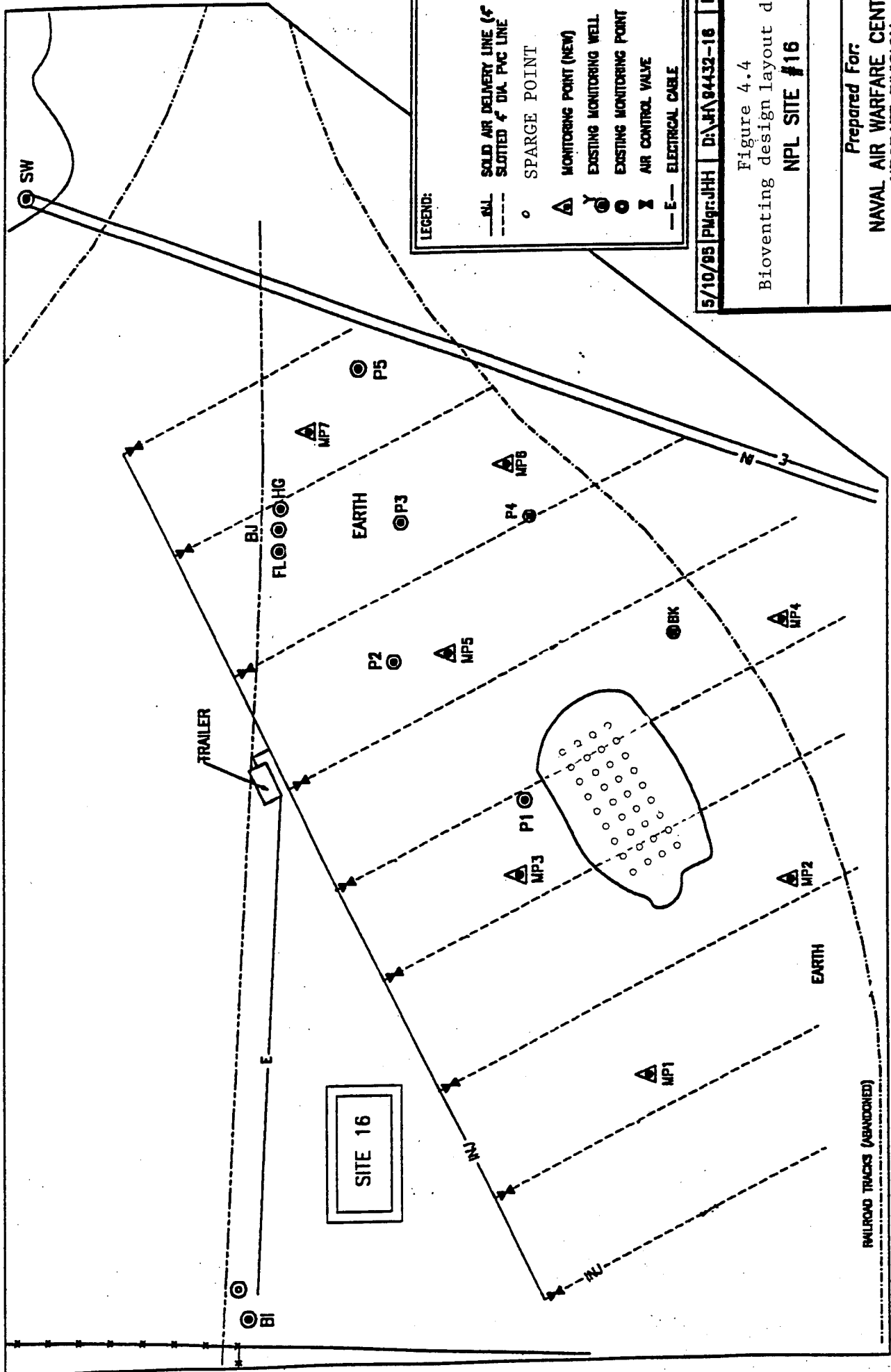

**LEGEND:**

- SOLID AIR DELIVERY LINE (4" PVC)
- - - - - SLOTTED 4" DIA. PVC LINE
- SPARGE POINT
- △ MONITORING POINT (NEW)
- ⊙ EXISTING MONITORING WELL
- ⊙ EXISTING MONITORING POINT
- ⊗ AIR CONTROL VALVE
- - - - - ELECTRICAL CABLE

5/10/95 PMgr:JHH | Dr:JH 94432-16 | LAYER: 0

Figure 4.4  
 Bioventing design layout diagram  
 NPL SITE #16

Prepared For:  
 NAVAL AIR WARFARE CENTER  
 AIRCRAFT DIVISION  
 LAKEHURST, NEW JERSEY  
 AQUATEX PROJECT No. 84432A

**Aquod-tex**  
 P.O. Box 1204  
 Hammonton, NJ  
 (809) 587-8280

Figure 4.5 Typical crosssection of injection piping

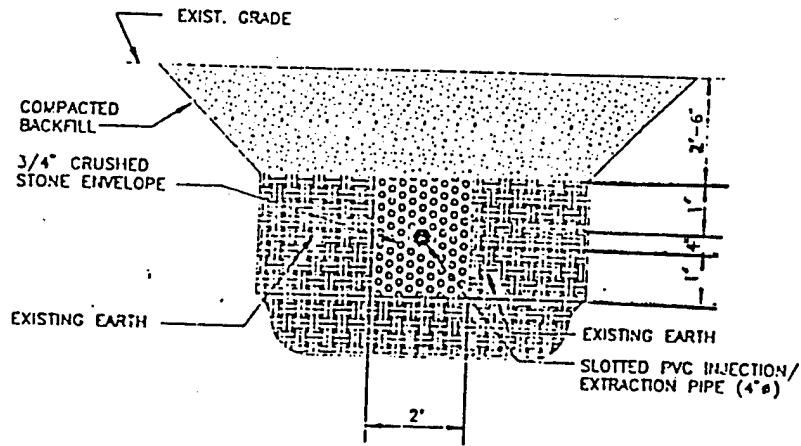
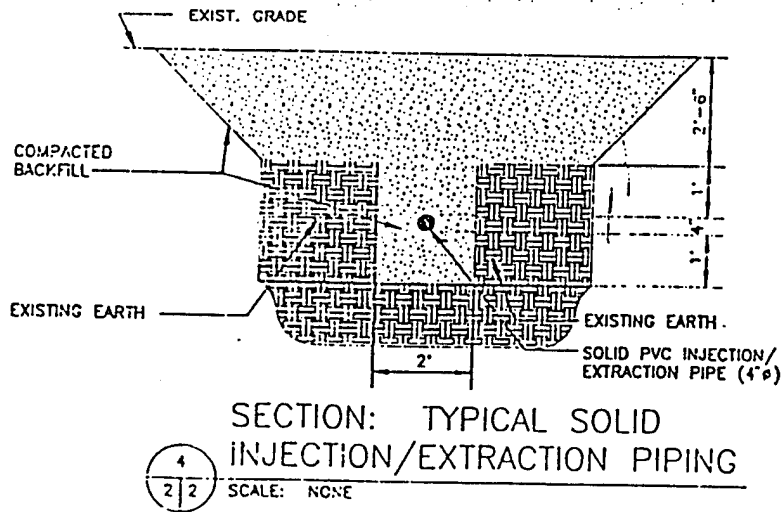

SLOTTED PVC INJECTION/EXTRACTION PIPING SHALL BE CAPPED OR PLUGGED AT ALL END POINTS.

Figure 4.6 Horizontal injection piping diagram

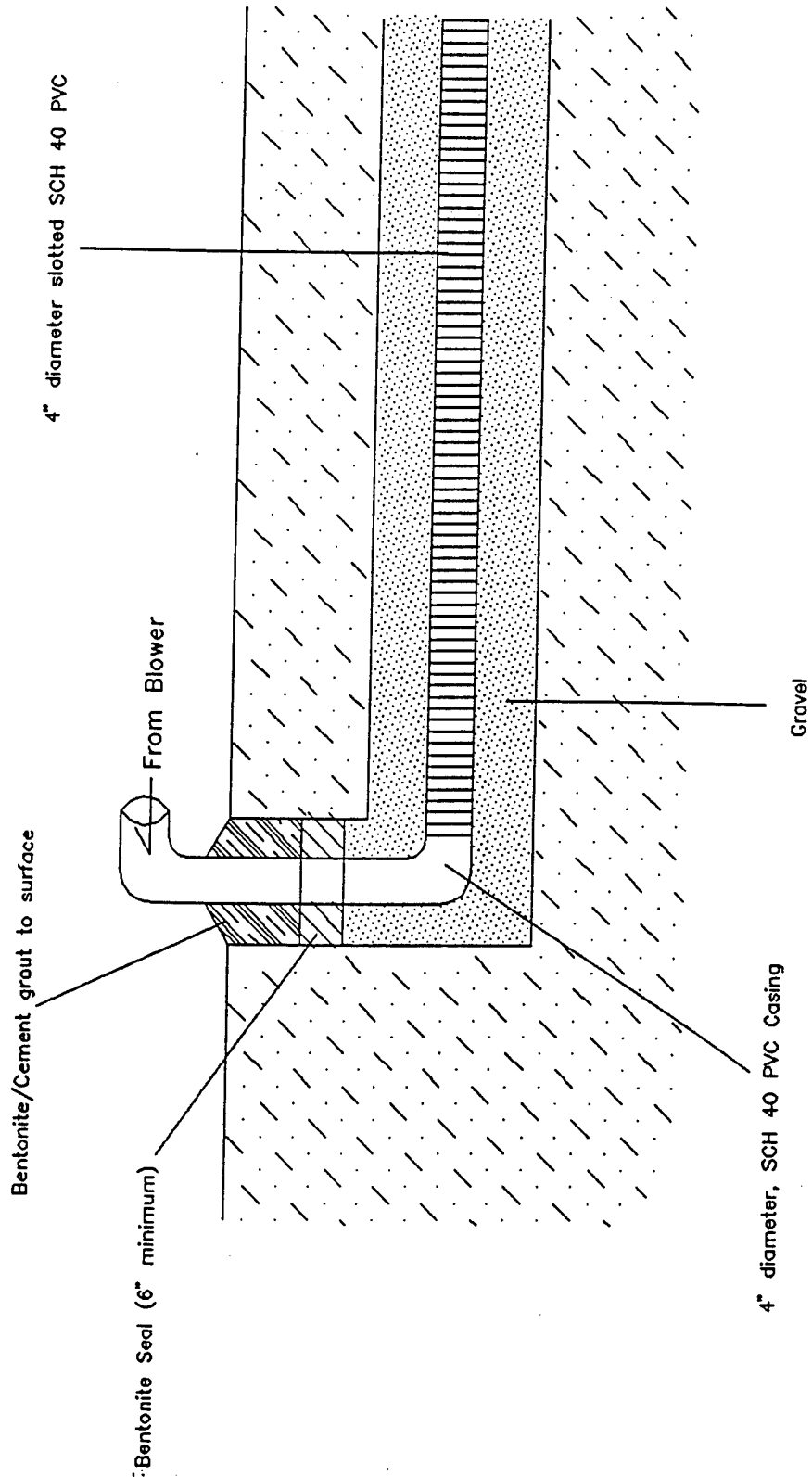

(Note: All mechanical joints, no glue permitted)

foot intervals and are at a depth of 3 1/2 feet. Figures 4.5 and 4.6 provide more details of the system.

A set of seven soil gas monitoring points, identified as MP1 - MP7, have been installed at various locations as shown in Figure 4.4. A typical monitoring point configuration is shown in Figure 4.7. Note that the gas probe screen has been placed at a depth of 3.5 ft.

As noted in the introduction, a small air sparge system has been installed within the lagoon area for remediation of saturated zone soils. This system consists of a group of 36 sparge points placed at 10 foot intervals within a 80ft x 30ft grid (Figure 4.4). Each sparge point is 10 feet deep and is constructed out of 1/4 inch diameter PVC piping. Due to the small radius of influence (5 feet) and distance to the nearest soil gas monitoring point (40 feet), no effect should be detected by the monitoring points.

#### ***4.4 Bioventing system operation and monitoring***

The bioventing system is provided with air by a single 3 horsepower blower rated at 50 standard cubic feet per minute and at a pressure of 100 inches of H<sub>2</sub>O. During system operation, the blower will be operated at full capacity and at a constant air flow rate. Initial operation of the system will only include six of the nine air injection lines. Three of the air injection lines will be closed off due to concerns that the blower may not be able to provide sufficient air flow to the entire system. The closed injection lines will be those located at the ends of the contaminated zone, two at the far west end and one at the far east end of the system. Operation in this manner will bias data from MP-1, since the monitoring point is located outside the radius of influence of the nearest operating air injection line.

Figure 4.7 TYPICAL MONITORING POINT CONFIGURATION

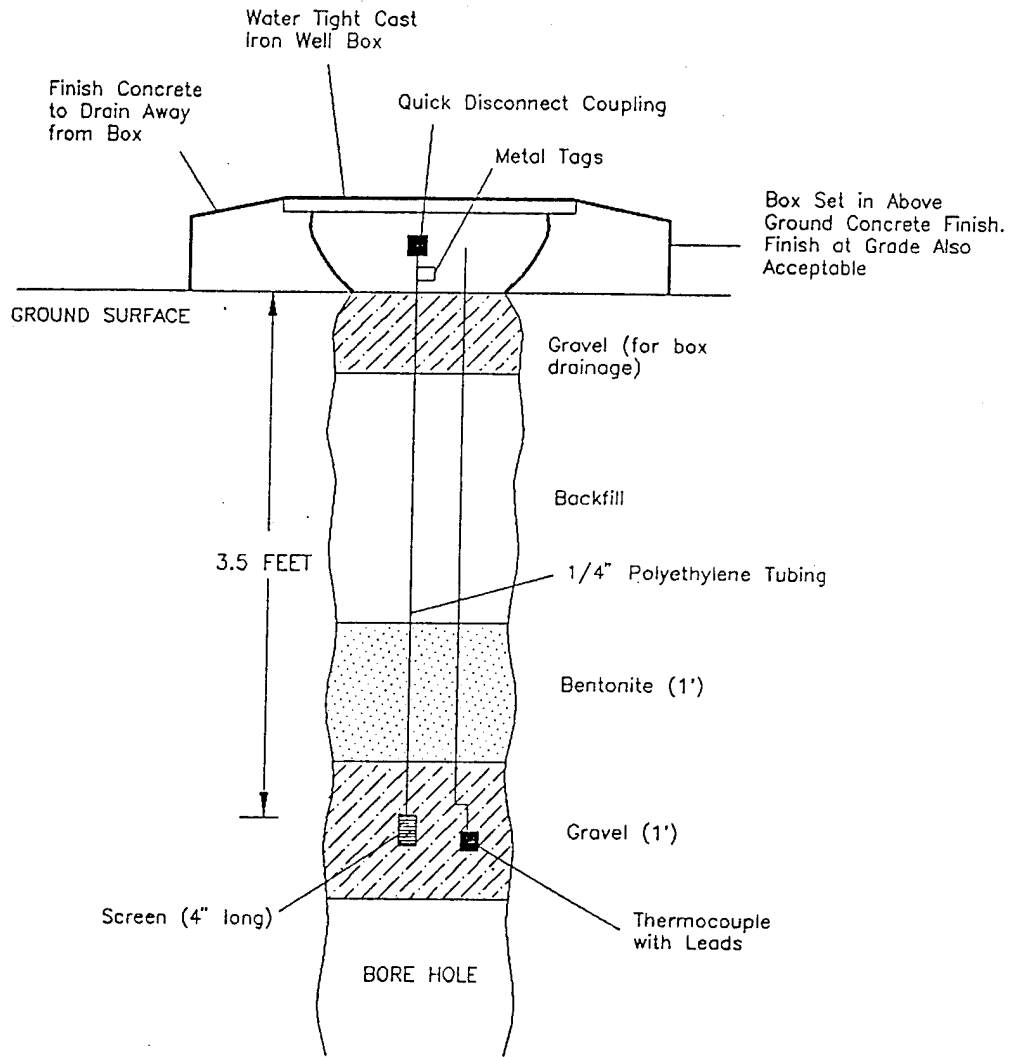

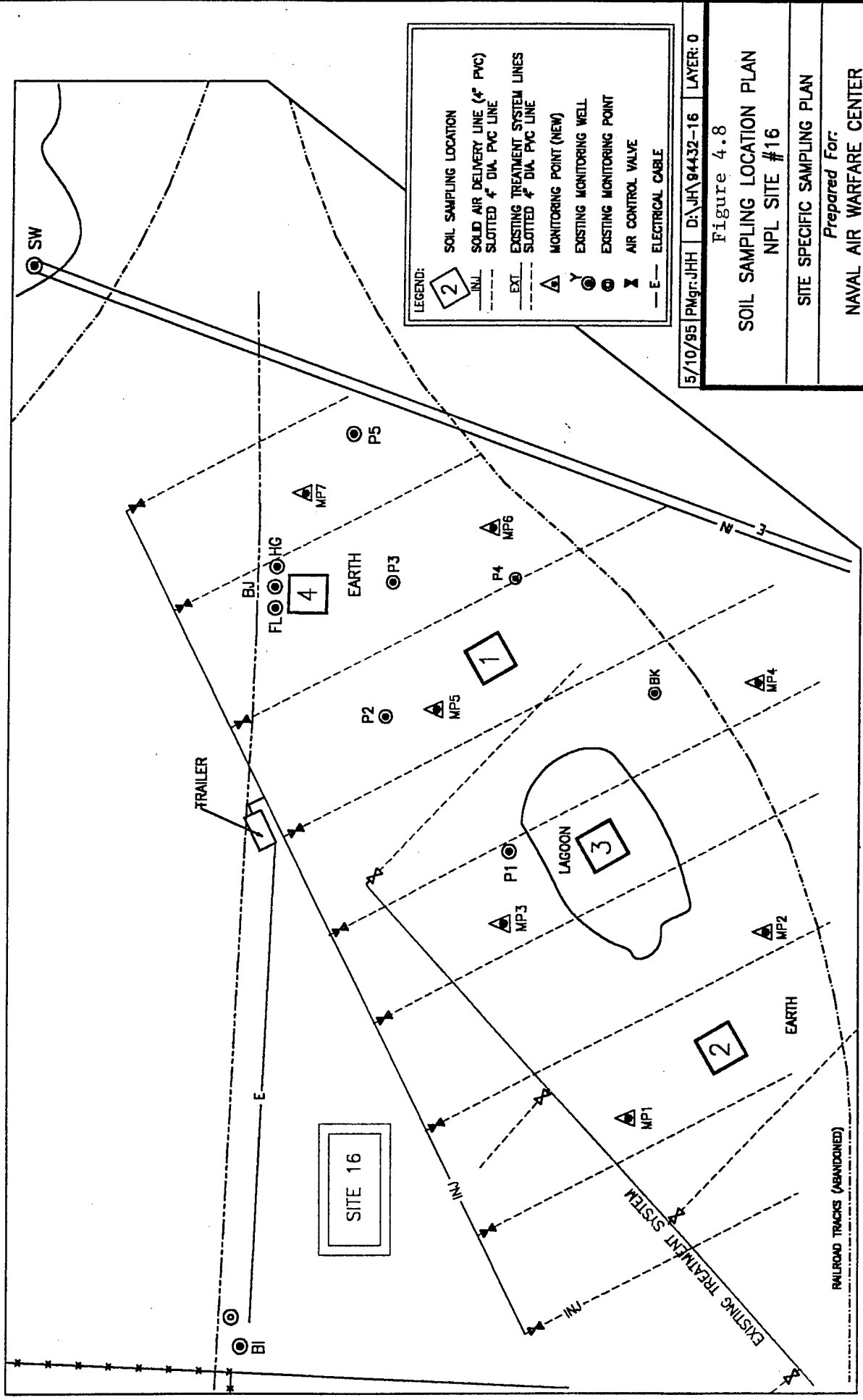

5/10/95 PMgr:JHH D:\JH\94432-16 LAYER: 0

Figure 4.8

SOIL SAMPLING LOCATION PLAN  
NPL SITE #16

SITE SPECIFIC SAMPLING PLAN

Prepared For:  
NAVAL AIR WARFARE CENTER  
AIRCRAFT DIVISION  
LAKEHURST, NEW JERSEY  
AQUATEX PROJECT No. 94432A

**Aquatex**  
P.O. Box 1204  
Hammonton, NJ  
(609) 567-8280

Several types of samples will be collected during planned sampling activities. These include: pre-treatment (baseline) soil samples, post-treatment soil samples, air quality samples and soil gas samples. Soil sampling will be performed at four designated study areas (Figure 4.8). Baseline soil sampling was performed prior to system start-up, with additional sampling to be performed after 3 and 6 months of operation, for a total of three sampling events. All soil samples collected from the four study areas will be collected at both three and five feet below grade, with the exception of the lagoon, where samples will be collected at one and three feet below grade.

Each soil sampling event will consist of a total of eight samples, with two samples being collected from each of the four study areas. Prior to sampling initiation, each designated sampling area will be divided into sixteen grids. Soil samples will be collected from two randomly selected grids at each study area. Once a grid location is sampled, it shall be marked and no additional samples will be collected from that grid. Sampling in this manner will allow for comparison of soil results within sample areas and between sample areas, allowing for the determination of the effectiveness of each in-situ bioremediation system. All soil samples will be analyzed for TPH, volatile organic compounds (VOCs) and semi volatile organic compounds (SVOCs).

Soil gas will be monitored at each of the seven soil gas monitoring points and at one existing background monitoring point. Soil gas monitoring will be performed on a bi-weekly basis beginning prior to start-up. Parameters for soil gas monitoring will include oxygen (O<sub>2</sub>), carbon dioxide (CO<sub>2</sub>) and VOCs. All soil gas samples will be analyzed using a calibrated analyzer.

Sampling of ambient air for VOCs will be performed during each of the bi-weekly soil gas monitoring events. The sampling will be performed to determine possible release of VOCs into the atmosphere. Ambient VOC measurements will be performed using a calibrated photo-ionization detector (PID) with a 10.2 eV lamp. Calibration will be against 100 ppm isobutylene and away from known sources of hydrocarbon for background. PID readings will be recorded at approximately three feet above grade at each of the soil gas monitoring points and directly above the horizontal air injection lines. Readings will be made prior to opening the monitoring point manholes. Obtaining repeat measurements at fixed locations will allow for comparison of results through time. In addition, the PID will be operated during the entire soil gas sampling procedure, with any areas away from the monitoring point experiencing elevated levels (above background) of VOCs noted. Table 4.1 provides a summary of the sampling protocol.

**Table 4.1 Sampling protocol**

Parameter	Matrix	Frequency	# of samples per event
VOCs	Soil	Background, 3 mo, 6 mo	16 soil samples
SVOCs	Soil	Background, 3 mo, 6 mo	16 soil samples
TPH	Soil	Background, 3 mo, 6 mo	16 soil samples
VOCs	Soil Vapor	Background, 3 mo, 6 mo	7 soil vapor samples
O <sub>2</sub>	Soil Vapor	Bi-weekly	7 monitoring points
CO <sub>2</sub>	Soil Vapor	Bi-weekly	7 monitoring points
VOCs	Ambient air	Bi-weekly	7 monitoring points
Temperature	Soil	Bi-weekly	7 monitoring points

Source: Aqua-tex, 1995

## **4.5 Discussion - site characterization and sampling protocol**

### **4.5.1 Site characterization**

The soil sampling results generally show that the highest TPH concentrations are found at the greater depths (3 - 4 ft) with lower concentrations found near the surface (1 - 2 ft). Since higher TPH concentrations allow for more degradation to occur, this could explain why Monitoring Well #2 of the respiration test showed much more activity at the 3.5 ft level than at the 1.5 ft level (see Figures 3.5 and 3.6).

The results also show a great variation in TPH concentrations in both the horizontal and vertical extent of the Site. To help visualize TPH concentrations as a function of depth, the average concentrations were calculated and plotted in Figure 4.9. The average TPH concentrations at the 3 - 4 ft. depth are about twice that at both the 1 - 2 and 5 - 6 ft. levels. Soils located within the A horizon (closest to the surface) typically have the highest microbial populations and availability of diffused oxygen. This allows for better conditions for natural attenuation than the deeper soils and could explain the lower TPH concentrations at the 1 - 2 ft. depths. The lower concentrations at the 5 - 6 ft. depths are not as straightforward, but a reasonable explanation does exist. Typically, most residue from fuel contaminated sites exists in the unsaturated zone soils in the capillary fringe (Hinchee and Miller, 1990). In this case the capillary fringe exists at about the 3 1/2 to 4 1/2 ft levels and is reflected in the highest concentrations at the 3 - 4 ft. levels. In addition, groundwater movement over a long period of time could have transported some of the contamination down gradient as well as providing dissolved

oxygen for bioremediation, possibly resulting in the lower TPH concentrations within the saturated zone (below 5ft.). This would be a slow process, but the Site is decades old.

**FIGURE 4.9 AVERAGE TPH CONCENTRATIONS AS A FUNCTION OF DEPTH**

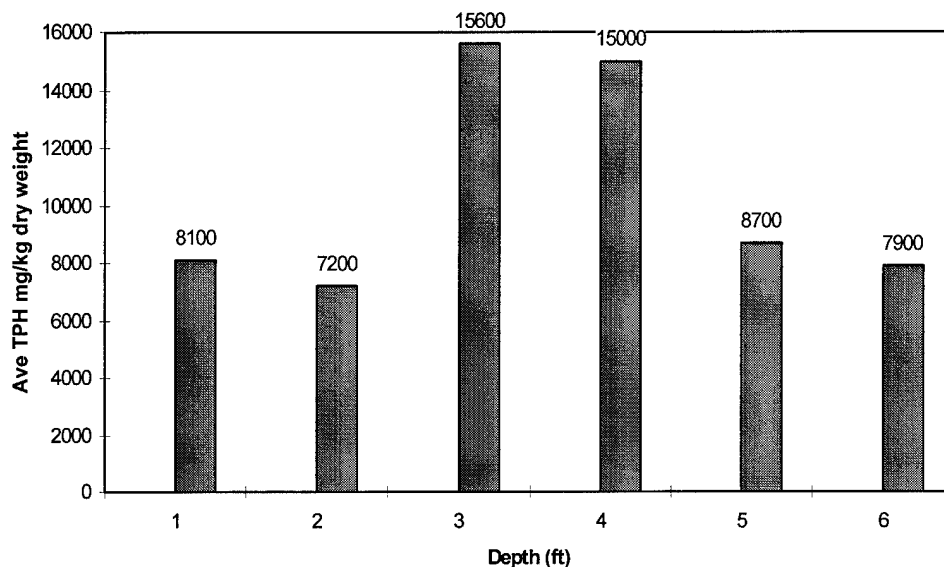

#### 4.5.2 Sampling protocol

The sampling protocol calls for soil sampling to be taken from four separate 25 ft. x 25 ft. grids, with two samples from each grid. Given the size of the soil sampling grids (625 ft<sup>2</sup>) and the vast heterogeneity of contamination, it will be difficult to determine if changes in the TPH concentrations are the result of biodegradation or just reflect the known Site heterogeneity. In addition, the frequency of sampling is to be at 0, 90, and 120 days from system start-up. Even at the highest calculated degradation rate of 6.89 mg/kg/day (Table 3.8), the expected reductions would only be 620 and 1240 mg/kg at 90 and 120 days respectively. These small reductions probably cannot be distinguished from the large heterogeneities that exist. In any case, it has not been shown that the soil

sampling protocol has been designed for statistical determination of actual remediation with any sort of confidence level.

On the other hand, the sampling protocol makes extensive use of soil gas sampling. This type of sampling is very important, particularly given the wide heterogeneity of the Site. Soil gas data represents the average chemistry of several cubic feet of soil as compared to only a few cubic inches for a discrete soil sample. Therefore, soil gas sampling will be more reflective of actual biodegradation and can be used to calculate the reductions in TPH concentrations. The soil gas sampling frequency of every two weeks is, however, much more than suggested by Hinchee, who recommends quarterly sampling (Hinchee, 1992). It is therefore recommended that the sampling frequency be extended based on the rate of changes experienced from the first few months of data. Sampling is only necessary when changes in the data can be reasonably expected.

#### ***4.6 Design comments***

The horizontal design layout is a very appropriate choice for this application due to the shallow water table in the area. In fact, horizontal wells are becoming increasingly common at sites with shallow contamination and large areal extent (Lewis, 1993). The injection well spacings at 60 ft intervals are consistent with the radius of influence obtained from the air permeability study. However, the the large horizontal spacings coupled with the shallow depths of the inection wells does raise a point of concern. There does not appear to be anything to prevent air flow from moving preferentially toward the surface, rather than in a horizontal direction. Air pressure will be lower at the surface

than within the soil matrix during venting, therefore the flow of air toward the surface is likely. It is not known if this issue was considered during design.

The injection well diameter was increased in size from 2 inches, used during the permeability study, to 4 inches for the actual system. This was presumably done to increase the radius of influence of the injection wells and thereby decrease the number of well installations required. The blower size, however, has a maximum design capacity of 200 CFM and may be undersized to accommodate oxygen demand. Hinchee recommends the blower to be sized to provide oxygen at a rate that exceeds the highest oxygen utilization rate. In this case, the highest utilization rate calculated from the in-situ respiration tests was 0.359 % O<sub>2</sub>/hr. The air flow required to meet this demand is 22 CFM. Assuming the design flow of 200 CFM is equally distributed among the nine injection wells, this will allow a flow rate of 22 CFM at each well. This rate, however, assumes an efficiency rate of 100%, and such will not be the case. Efficiency factors are likely to be on the order of 10%, requiring 10 times the amount of air flow presently available.

#### ***4.7 Design and sampling protocol conclusions and recommendations***

All soil sampling results have shown a wide variation in TPH concentrations. This variability, coupled with the relatively small reductions that can be expected at the scheduled sampling frequency and the lack of a statistical basis for comparative reductions in TPH concentrations, limits the usefulness of the sampling data. It is recommended that monitoring personnel rely on soil gas sampling to determine system efficiency and calculate TPH reductions. Also, the soil sampling should not occur until

the soil gas CO<sub>2</sub> concentration approaches background levels. A statistical approach should be used to determine contaminant concentrations with specified confidence levels.

The sampling protocol calls for bi-weekly sampling of soil gas concentrations which is much more frequent than necessary. It is recommended that the soil gas sampling frequency be reduced to a schedule where changes can be reasonably expected to be noticeable, based on how quickly changes are noted during the first few months.

Other than oxygen delivery, soil moisture content is likely to be the most critical element of concern during the life of the operating system. It is recommended that the soil moisture content be monitored if conditions appear to be too dry and that water be added if it falls below 8 %. The system can also be shut down during extended periods heavy rainfall.

## 5.0 Initial soil and soil gas sampling data

This report intended to use several months of soil gas testing and at least one set of post start-up soil sampling results to describe system performance and determine the impact of head losses along the length of the horizontal injection wells. However due to extended contractual delays between the Navy and the contractor performing the work, only one set of post start-up soil gas data was available within the timeframe allowed for completion of this report. The data available, however, does provide good preliminary information and is discussed below.

### 5.1 Soil sampling data

Prestart-up soil sampling was performed on 20 July, 1995. Results are shown in Table 5.1. For soil grid locations, refer to Figure 4.8.

**Table 5.1 Prestart-up soil TPH concentrations**

Grid #	Sample depth (ft)	TPH mg/kg dry weight
1	3	4260
1	5	2270
2	3	14800
2	5	2400
3	1	9200
3	3	4240
4	3	462
4	5	3930

The results of the soil sampling continue to show a wide variation in TPH concentrations over the areal and vertical extent of the Site, varying by as much as two orders of magnitude. This is similar to previous soil testing data and, again, highlights the difficulty that will be encountered in determining actual TPH reductions by sampling

in this manner at the 90 and 180 day sampling dates. The maximum concentration of 14,800 mg/kg (dry weight) is only about half the maximum concentration of 29,000 mg/kg previously reported but is not unusual given the limited number of samples taken coupled with the large area (49,000 ft<sup>2</sup>) and vast heterogeneity of soil contamination throughout the site. The TPH concentrations did show higher concentrations at the three foot level on two of the four grids, similar to earlier soil sampling results as discussed in Section 4.5. However, a definite trend cannot be determined, given the number of samples taken.

### 5.2 Soil gas data

Prestart-up soil gas samples were taken on 3 August, 1995. Results are provided in Table 5.2.

**Table 5.2 Prestart-up soil gas sampling results**

Monitoring point	O <sub>2</sub> (%)	CO <sub>2</sub> (%)	<sup>1</sup> VOCs (ppmv)	<sup>2</sup> VOCs (ppmv)
MP1	3.4	15.6	140	0.0
MP2	0.0	15.9	481	0.0
MP3	0.0	14.1	475	0.0
MP4	8.4	8.9	474	0.0
MP5	0.0	14.0	386	0.0
MP6	0.0	10.4	29	0.0
MP7	9.4	7.1	109	0.0

<sup>1</sup> VOCs sampled within monitoring point

<sup>2</sup> VOCs ambient air sampled @ 3 ft. above injection well

The soil gas sampling results show that O<sub>2</sub> levels are completely depleted at Monitoring Points 2, 3, 5 and 6, indicating that natural diffusion is not meeting the biological oxygen demand of fuel degrading microorganisms at these locations. These

locations also show elevated concentrations of CO<sub>2</sub>, as compared to previously measured background levels of about 1%, indicating that this primary biodegradation by-product is also being produced. Hinchee describes oxygen concentrations to be limiting at levels below 2% and nonlimiting at concentrations above 5% (Hinchee et al. 1992). Monitoring Point 1, while not depleted of oxygen, is at a low level and probably indicates oxygen limitations since CO<sub>2</sub> production is at similar levels as Monitoring Points 2, 3, 5, and 6, where O<sub>2</sub> is completely depleted. Monitoring Points 4 and 7 show reduced concentrations of oxygen, but remain at concentrations sufficient to be nonlimiting. The CO<sub>2</sub> concentration is about half that of the other Monitoring Points, showing reduced levels of microbial activity. Since Monitoring Points, 4 and 7 are located on the outside fringe of the contaminated zone, the reduced microbial activity in a non-oxygen limiting environment indicates reduced contaminant concentrations. All samples showed relatively low levels of VOCs within the Monitoring Wells indicating that the petroleum contamination is somewhat weathered which is expected due to the age of the site. VOCs were not detected above the monitoring points, also as expected, due to the low concentrations found within the monitoring points and the lack of a transport mechanism.

Poststart-up soil gas sampling was performed after one week of continuous operation. The first poststart-up soil gas samples, originally scheduled to be taken after two weeks of operation, were taken earlier after consideration was given to how quickly the Site equilibrated during the respiration and air permeability tests and the desire identify problems and make system adjustments as early as possible. The results are presented in Table 5.3.

**Table 5.3 Soil gas sampling results after one week of operation**

Monitoring point	O <sub>2</sub> (%)	CO <sub>2</sub> (%)	<sup>1</sup> VOCs (ppmv)	<sup>2</sup> VOCs (ppmv)
*MP1	0	25	85	0
MP2	8.5	9	373	0
MP3	0	25	292	0
MP4	2	19	229	0
MP5	19	1	238	0
MP6	0	21	281	0
MP7	0	20	181	0

<sup>1</sup> VOCs sampled within monitoring point

<sup>2</sup> VOCs ambient air sampled @ 3 ft. above injection well

\* MP1 is outside the radius of influence of the nearest operating injection well

While some of the individual monitoring points gave conflicting results, such as decreases in O<sub>2</sub> concentration after system start up, the limited data does provide useful information. In general, oxygen concentrations remained limiting at five of the seven monitoring points suggesting that adequate delivery of air is not being provided throughout most of the system. This supports the previous discussion that the blower may be undersized to meet the oxygen demand, particularly in light of the fact that only six of the nine injection wells are operating. In addition, since no detectable VOCs are present above the monitoring points, airflow rates at current levels are not producing the volatilization of organics that would be indicative of excessive airflow. Therefore, early indications suggest that the airflow delivery is inadequate. Several more weeks of soil gas testing could confirm this suggestion. It is noted here that monitoring of VOCs should be monitored in locations where they are most likely to occur. In this regard,

above the sparging points would be an likely choice since this process strips volatiles from the saturated soils and a vapor extraction system is not present to capture them. Another reasonable sampling location is at the beginning of the injection wells, where flow rates will be the highest.

Increased levels of CO<sub>2</sub> concentrations within most of the monitoring points does indicate that the airflow that is being provided has resulted in increased microbial activity. Therefore, the bioventing system is enhancing biodegradation of peroleum contamination.

It is evident from the high oxygen concentrations at monitoring point 5, that it is receiving more airflow than are the other monitoring points. The reason for this does not appear to be head losses at the other monitoring points along the length of the slotted injection wells. Table 5.4 shows oxygen concentrations after one week of bioventing and the length of the slotted injection piping closest to the monitoring points. The Monitoring Points are listed in order of shortest to longest.

**Table 5.4 Oxygen concentrations after 1 week of biventing and associated injection well pipe length**

Monitoring Point	O <sub>2</sub> (%)	length (ft)
MP3	0	91
MP7	0	96
MP5	19	109
MP6	0	182
MP2	8.5	218
MP4	2	274

As is shown from the Table, the monitoring points initially showed that oxygen delivery does not appear to be a function of injection well pipe length. At the current

time however, it is not possible to determine if air flow rates or pressure changes are significant based on these oxygen concentrations. The system has not yet been in operation long enough and at high enough flow rates to link potential head losses along the length of the injection wells to oxygen concentrations at the Monitoring Points. Ideally, installation of pressure gauges at the beginning and ends of the injection wells would provide the most accurate information for this type of analysis. However, long term soil gas monitoring at higher air flow rates should be suitable to at least qualitatively determine if head losses or reductions in air flow rates are significant.

### ***5.3 Conclusions and recommendations***

Oxygen concentrations are still limiting at most monitoring locations after one week of system operation, therefore soil gas testing should be continued to confirm if oxygen concentrations remain at limiting levels. If the concentrations continue to remain low, only one vent well should be operated until soil gas concentrations stabilize. Then additional vent wells can be added until oxygen levels fall below 5 %. A new blower can be added based on the number of non-operating wells remaining.

CO<sub>2</sub> increases in most monitoring wells indicates an increased level of microbial activity due to the addition of air by the bioventing system but contaminant degradation still appears to be oxygen limiting. Therefore an attempt should be made to maximize microbial production by increasing flow to the Site.

VOCs are not being produced and are not detected in the air above the monitoring points. Therefore VOC monitoring should be continued, but to locations above the

beginning of the injection wells and above the sparge points, as that is where VOCs are most likely to be generated.

## **6.0 SUMMARY CONCLUSIONS AND RECOMMENDATIONS**

The conclusions and recommendations presented in the preceding chapters are summarized here in terms of 1) feasibility studies, 2) system design and sampling protocol, and 3) system operation and effectiveness.

### ***6.1 Feasibility Studies***

The in-situ respiration tests showed a rapid drop in helium concentrations at all monitoring points, indicating possible short circuiting due to improper monitoring point installation. It is therefore recommended that a performance requirement be included in future contracts to indicate that a fractional loss of helium concentration cannot exceed 40% of in a 100 hour period.

Measurements of vent well air flow and pressure were not included during the air permeability tests, requiring these parameters to be estimated. It is recommended that these measurements be included as part of the contract requirements for air permeability tests to allow more accurate calculation of soil permeability.

During the in-situ respiration tests, only four of the six installed monitoring points were utilized during data collection. It is recommended that all installed monitoring points be utilized during data collection.

Natural attenuation was never eliminated as a possible preferred alternative. The air permeability tests gave no indication that oxygen was indeed limiting and therefore further investigation was warranted. It is therefore recommended that a soil gas survey be included as part of future bioventing feasibility studies. A soil gas survey will show if

natural attenuation is a possible alternative, will assist in defining the extent of contamination and will aid in bioventing system design, should bioventing be necessary.

## ***6.2 System Design and Sampling Protocol***

All soil sampling results have shown a wide variation in TPH concentrations. This variability, coupled with the relatively small reductions that can be expected at the scheduled sampling frequency and the lack of a statistical basis for comparative reductions in TPH concentrations, limits the usefulness of the sampling data. It is recommended that monitoring personnel rely on soil gas sampling to determine system efficiency and calculate TPH reductions. Also, the soil sampling should not occur until the soil gas CO<sub>2</sub> concentration approaches background levels. A statistical approach should be used to determine contaminant concentrations with specified confidence levels.

The sampling protocol calls for bi-weekly sampling of soil gas concentrations which is much more frequent than necessary. It is recommended that the soil gas sampling frequency be reduced to a schedule where changes can be reasonably expected to be noticeable, based on how quickly changes are noted during the first few months.

Other than oxygen delivery, soil moisture content is likely to be the most critical element of concern during the life of the operating system. It is recommended that the soil moisture content be monitored if conditions appear to be too dry and that water be added if it falls below 8 %. The system can also be shut down during extended periods heavy rainfall.

### **6.3 System Operation and Effectiveness**

Oxygen concentrations are still limiting at most monitoring locations after one week of system operation, therefore soil gas testing should be continued to confirm if oxygen concentrations remain at limiting levels. If the concentrations continue to remain low, only one vent well should be operated until soil gas concentrations stabilize. Then additional vent wells can be added until oxygen levels fall below 5 %. A new blower can be added based on the number of non-operating wells remaining.

CO<sub>2</sub> increases in most monitoring wells indicates an increased level of microbial activity due to the addition of air by the bioventing system but contaminant degradation still appears to be oxygen limiting. Therefore an attempt should be made to maximize microbial production by increasing flow to the Site.

VOCs are not being produced and are not detected in the air above the monitoring points. Therefore VOC monitoring should be continued, but to locations above the beginning of the injection wells and above the sparge points, as that is where VOCs are most likely to be generated.

## **APPENDIX A**

In-situ respiration results

**In Situ Respiration Test**

**Lakehurst, NJ**

**Site: 16 Date: 14 June 1994**

**Monitoring Point: 16/17 Background Well**

**O2 Meter MSA Model No. 1072**

**CO2 Meter No. 0004003 Riken RI-411**

**Shut down date/time: 15 June 1994 1405 hrs**

Date	Time	Elapsed Time (hr)	CO2 %	O2 %	Helium	Temp deg Cel.
15-Jun-94	1433	0.5	0.09	20.6	1.71	22.4
15-Jun-94	1500	0.9	0.09	20.6	1.56	21.6
15-Jun-94	1613	2.1	0.09	20.6	1.2	21.4
15-Jun-94	1700	2.9	0.09	20.6	1.26	21.1
15-Jun-94	2001	5.9	0.18	20.5	1.26	20.3
15-Jun-94	2326	9.4	0.27	20.4	0.85	20.7
16-Jun-94	725	17.3	0.45	20.3	0.64	20.7
16-Jun-94	1715	27.2	0.55	20.1	0.62	20.9
16-Jun-94	2333	33.5	0.64	20	0.28	20.6
17-Jun-94	844	42.6	0.73	20	0.18	20.6
17-Jun-94	1435	48.5	0.82	19.8	0.08	20.4
17-Jun-94	2331	57.4	0.91	19.5	0.12	20.8
18-Jun-94	818	66.2	1.09	19.4	0.12	20.6
18-Jun-94	1530	73.4	1.18	19.5	0.06	20.8
18-Jun-94	2317	81.2	1.18	19.4	0.08	20.9
19-Jun-94	754	89.8	1.18	19.3	0.04	20.7
19-Jun-94	1602	98.0	1.27	19.3	0.01	20.9
20-Jun-94	844	114.5	1.27	19.2	0	20.8

In Situ Respiration Test

Lakehurst, NJ

Site: 16 Date: 13 June 1994

Monitoring Point: 16-1-3.5

O2 Meter MSA Model No. 1072

CO2 Meter No. 0004003 Riken RI-411

Shut down date/time: 14 June 1994 1220 hrs

Date	Time	Elapsed Time (hr)	CO2 %	O2 %	Helium	Temp1* deg Cel.	Temp2** deg Cel.
14-Jun-94	1240	0.3	0.09	20.4	1.56	NT	NT
14-Jun-94	1320	1.0	0.18	20.2	1.3	18.6	21.4
14-Jun-94	1426	2.0	0.35	19.6	1.36	18.5	21.7
14-Jun-94	1522	3.0	0.44	19.1	1.2	19.2	22.3
14-Jun-94	1728	5.1	0.70	18.2	1.24	19.2	22.5
14-Jun-94	2025	8.1	1.14	16.8	1.29	18.9	23.4
14-Jun-94	2327	11.1	1.49	15.5	1.16	19.7	24.3
15-Jun-94	845	20.4	2.19	12.7	0.77	18.8	22.9
15-Jun-94	1555	27.6	3.51	9.6	0.58	20.2	26.9
15-Jun-94	2309	34.7	3.77	7.8	0.58	20	25
16-Jun-94	735	43.3	5.00	5.1	0.5	20	24.3
16-Jun-94	1730	53.2	5.18	4.8	0.38	20.2	23.8
16-Jun-94	2313	58.9	5.61	3.5	0.28	20.1	23.7
17-Jun-94	831	68.2	5.35	3.4	0.16	20.2	23.1
17-Jun-94	1415	73.9	5.53	3.4	0.15	19.1	22.5
17-Jun-94	2315	82.9	6.05	3.3	0.08	20.6	24.7
18-Jun-94	805	91.8	6.64	4.4	0.02	20.4	23.8
18-Jun-94	1519	99.0	7.45	4.3	0.04	20.9	24.1
18-Jun-94	2302	106.7	7.36	4.3	0.02	20.7	24
19-Jun-94	734	115.2	7.18	4.4	0.01	21	24.9
19-Jun-94	1549	123.5	8.36	4	0.01	21.2	25.4

\* Temp1 from point 16-1-3.5

\*\* Temp2 from point 16-1-1.5

**In Situ Respiration Test**

Lakehurst, NJ

Site: 16 Date: 13 June 1994

Monitoring Point: 16-2-1.5

O2 Meter MSA Model No. 1072

CO2 Meter No. 0004003 Riken RI-411

Shut down date/time: 14 June 1994 1220 hrs

Date	Time	Elapsed Time (hr)	CO2 %	O2 %	Helium
14-Jun-94	1246	0.4	0.00	20.5	1.56
14-Jun-94	1325	1.1	0.00	20.6	1.1
14-Jun-94	1432	2.2	0.09	20.5	0.95
14-Jun-94	1528	3.1	0.09	20.5	0.83
14-Jun-94	1733	5.2	0.18	20.4	0.67
14-Jun-94	2029	8.1	0.26	20.1	0.56
14-Jun-94	2332	11.2	0.35	20.2	0.37
15-Jun-94	845	20.4	0.53	19.5	0.06
15-Jun-94	1601	27.7	0.88	19.3	0.03
15-Jun-94	2315	34.9	1.05	19.1	0.04
16-Jun-94	738	43.3	1.32	18.7	0.02
16-Jun-94	1730	53.2	1.49	18.5	0
16-Jun-94	2322	59.0	1.49	18.3	0.03
17-Jun-94	834	68.2	1.40	18	0.02
17-Jun-94	1430	74.2	1.49	18	0.02
17-Jun-94	2321	83.0	1.67	17.8	0
18-Jun-94	811	91.8	1.82	18.5	0
18-Jun-94	1523	99.0	2.00	18.2	0.02
18-Jun-94	2308	106.8	2.00	18.3	0
19-Jun-94	741	115.3	2.09	18.2	0
19-Jun-94	1553	123.4	2.18	18.3	0

**In Situ Respiration Test**

Lakehurst, NJ

Site: 16 Date: 13 June 1994

Monitoring Point: 16-2-3.5

O2 Meter MSA Model No. 1072

CO2 Meter No. 0004003 Riken RI-41

Shut down date/time: 14 June 1994 1220 hrs

Date	Time	Elapsed Time (hr)	CO2 %	O2 %	Helium
14-Jun-94	1243	0.4	0.00	20.2	2.57
14-Jun-94	1323	1	0.09	20.4	1.42
14-Jun-94	1430	2.2	0.18	20.3	1.42
14-Jun-94	1526	3.1	0.18	20.1	1.31
14-Jun-94	1730	5.2	0.35	19.8	1.19
14-Jun-94	2031	8.2	0.61	19.3	1.7
14-Jun-94	2330	11.2	0.79	19	0.85
15-Jun-94	845	20.4	1.05	17.7	0.26
15-Jun-94	1557	27.6	1.67	16.9	0.15
15-Jun-94	2317	35	2.02	16.2	0.06
16-Jun-94	740	43.3	2.54	15.3	0.02
16-Jun-94	1730	53.2	2.72	14.9	0.02
16-Jun-94	2324	59.1	3.16	14.2	0
17-Jun-94	836	68.3	3.16	13.5	0
17-Jun-94	1425	74.1	3.25	13.1	0.02
17-Jun-94	2319	83	3.68	13.1	0.02
18-Jun-94	809	91.8	4.27	14	0.02
18-Jun-94	1523	99	4.73	13.9	0
18-Jun-94	2306	106.8	4.82	13.8	0.02
19-Jun-94	739	115.3	5.00	13.7	0.02
19-Jun-94	1555	123.6	5.64	13.5	0.02

**In Situ Respiration Test**

Lakehurst, NJ

Site: 16 Date: 13 June 1994

Monitoring Point: 16-3-1.5

O2 Meter MSA Model No. 1072

CO2 Meter No. 0004003 Riken RI-411

Shut down date/time: 14 June 1994 1220 hrs

Date	Time	Elapsed Time (hr)	CO2 %	O2 %	Helium
14-Jun-94	1250	0.5	0.09	20.2	1.42
14-Jun-94	1328	1.1	0.18	20.1	1.25
14-Jun-94	1433	2.2	0.35	19.8	1.25
14-Jun-94	1531	3.1	0.44	19.4	1.12
14-Jun-94	1736	5.1	0.61	18.8	9.8
14-Jun-94	2024	8.1	1.05	17.8	0.83
14-Jun-94	2337	11.3	1.40	17.1	0.6
15-Jun-94	845	20.4	1.75	14.9	0.28
15-Jun-94	1605	27.7	3.07	13.6	0.16
15-Jun-94	2321	35.0	3.51	12.2	0.09
16-Jun-94	743	43.4	4.39	11	0.04
16-Jun-94	1730	53.2	4.65	10.3	0.03
16-Jun-94	2327	59.1	5.53	9.1	0
17-Jun-94	839	68.3	5.53	8.8	0
17-Jun-94	1435	74.2	5.70	8.4	0
17-Jun-94	2325	83.1	6.05	8.3	0
18-Jun-94	814	91.9	6.91	9.9	0
18-Jun-94	1626	100.1	7.64	9.7	0
18-Jun-94	2311	106.9	7.82	9.7	0
19-Jun-94	747	114.8	7.91	9.6	0
19-Jun-94	1557	123.6	8.45	9.5	0

## REFERENCES

AFCEE, Bioventing Performance and Cost Summary, prepared by the Air Force Center for Environmental Excellence (AFCEE), Brooks AFB, Texas, July 1994.

Aguilar Associates & Consultants, Inc., Report of Findings, "Treatability Testing for Bioventing at NPL Sites 13, 16, and 17", prepared for Naval Air Engineering Station, Lakehurst, New Jersey, 1994.

Aqua-tex, Quality Assurance/Quality Control and Site Specific Sampling and Analysis Plan, prepared for Naval Air Engineering Station, Lakehurst, New Jersey, 8 May, 1995.

Cookson, J.T., Bioremediation Engineering, Design and Application, McGraw-Hill Inc., 1995.

Dames & Moore, Navy Assessment and Control of Installation Pollutants, Remedial Investigation - Phase III, prepared for Naval Air Engineering Center, Lakehurst, New Jersey, July 1990.

Downey, D.C., Hall, J.F., Mikdisi, R.S., Baskin, D., "Results of Bioventing Test in Clay Soils", Proceedings of Emerging Technologies for Hazardous Waste Management, ACS Special Symposium, Atlanta, GA, 1992.

Downey, D.C., Hall, J.F., Addendum One to Test Plan and Technical Protocol for a Field Treatability Test for Bioventing - Using Soil Gas Surveys to Determine Bioventing Feasibility and Natural Attenuation Potential, prepared for US Air Force, February 1994.

English, C. W., and Loehr, R. C., "Degradation of Organic Vapors in Unsaturated Soils", Bioremediation Fundamentals and Effective Application, Proceedings of the 3rd Annual Symposium at the Gulf Coast Hazardous Substance Research Center, pp. 65-74, February, 1991.

ERI, Feasibility Study for Land Treatment of Hydrocarbon Contaminated Soil at the Naval Engineering Center in Lakehurst, New Jersey, prepared by Environmental Remediation, Inc. (ERI), June 1990.

Hinchee, R. E. and M. F. Arthur, "Bench-scale Studies on the Soil Aeration Process for Bioremediation of Petroleum-Contaminated Soils", Journal of the Applied Biochemistry and Biotechnology, 28/29:901-906, 1990.

Hinchee, R.E., Ong, S.K., Miller, R.N., Downey D.C., Frandt R. Test Plan and Technical Protocol for a Field Treatability Test for Bioventing, prepared for the U.S. Air Force, May 1992.

Hinchee, R.E., Bioventing: Principles, Applications and Case Studies, Training Program of International Network for Environmental Training, Potomac, Md., 1993b.

Hoepfel, R.E., Hinchee, R.E., and Arthur, M.R., "Bioventing Soils Contaminated with Petroleum Hydrocarbons", Journal of Industrial Microbiology, Vol 8, 1991.

INET, "Bioventing : Principles, Applications and Case Studies", Training Program Manual, International Network for Environmental Training, Inc., Potomac, Md., pp 7.1-7.26, 1993.

Johnson, P.C., M.W. Kemblowski, and J.D. Colthart "Quantitative Analysis for the Cleanup of Hydrocarbon - Contaminated Soils by In - Situ Soil Venting", Ground Water, 28(3), May - June, 1990.

Lewis, W., "Horizontal Wells Can Lower Costs of Remediating Soil", Oil and Gas Journal, Nov. 29, 1993, V91, n48.

New American Standard Bible, Book of Ephesians, Chapter 5, Verse 20, Foundation Press, 1973.

Norris, Hinchee, Brown, McCarty, Semprini, Wilson, Kampbell, Reinhard, Bouwer, Borden, Vogel, Thomas and Ward, Handbook of Bioremediation, Lewis Publishers, 1994.

Stanier, R. Y., Ingraham, J. L., and Painter, P.R., The Microbial World, 5th edition, Prentice-Hall, Englewood Cliffs, N.J., 1986.

U.S. EPA, Test Methods for Evaluating Solid Wastes, 3rd edition SW 846, 1986.

## VITA

Nickolas Fidel Florez, the second child of Linda and Richard Florez, was born in Ajo, Arizona on September 11, 1959. He attended Camelback High School in Phoenix, Arizona where he graduated in 1978. After several years working in the mining and construction industry, he attended the University of Arizona where he received his Bachelor of Mining Engineering degree in December of 1987. After graduation, he joined the Civil Engineer Corps of the U.S. Navy. In 1994, still with the Navy, he entered the Graduate School of the University of Texas at Austin.

Permanent address:                   6602 N 7th Ave  
  Phoenix, AZ 85013

This report was typed by Virginia Florez.