

RL-TR-95-101
Final Technical Report
June 1995

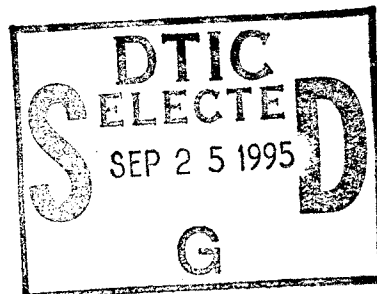

MODELOCKING AND WAVEGUIDE AMPLIFIERS USING Cr: FORSTERITE AND Cr: YAG

Cornell University
Clifford R. Pollock



APPROVED FOR PUBLIC RELEASE; DISTRIBUTION UNLIMITED.

19950919 208

Rome Laboratory
Air Force Materiel Command
Griffiss Air Force Base, New York

DTIC QUALITY INSPECTED 8

This report has been reviewed by the Rome Laboratory Public Affairs Office (PA) and is releasable to the National Technical Information Service (NTIS). At NTIS it will be releasable to the general public, including foreign nations.

RL-TR-95-101 has been reviewed and is approved for publication.

APPROVED:



STEVEN T. JOHNS
Project Engineer

FOR THE COMMANDER:



FRED J. DEMMA
Acting Director
Surveillance & Photonics Directorate

If your address has changed or if you wish to be removed from the Rome Laboratory mailing list, or if the addressee is no longer employed by your organization, please notify RL (OCPA) Griffiss AFB NY 13441. This will assist us in maintaining a current mailing list.

Do not return copies of this report unless contractual obligations or notices on a specific document require that it be returned.

REPORT DOCUMENTATION PAGE

Form Approved
OMB No. 0704-0188

Public reporting burden for this collection of information is estimated to average 1 hour per response, including the time for reviewing instructions, searching existing data sources, gathering and maintaining the data needed, and completing and reviewing the collection of information. Send comments regarding this burden estimate or any other aspect of this collection of information, including suggestions for reducing this burden, to Washington Headquarters Services, Directorate for Information Operations and Reports, 1215 Jefferson Davis Highway, Suite 1204, Arlington, VA 22202-4302, and to the Office of Management and Budget, Paperwork Reduction Project (0704-0188), Washington, DC 20503.

1. AGENCY USE ONLY (Leave Blank)		2. REPORT DATE June 1995		3. REPORT TYPE AND DATES COVERED Final Jan 94 - Jan 95	
4. TITLE AND SUBTITLE MODELOCKING AND WAVEGUIDE AMPLIFIERS USING Cr:FORSTERITE AND Cr:YAG				5. FUNDING NUMBERS C - F30602-94-C-0030 PE - 62702F PR - 4600 TA - P1 WU - PZ	
6. AUTHOR(S) Clifford R. Pollock					
7. PERFORMING ORGANIZATION NAME(S) AND ADDRESS(ES) Cornell University School of Electric Engineering Ithaca NY 14853				8. PERFORMING ORGANIZATION REPORT NUMBER N/A	
9. SPONSORING/MONITORING AGENCY NAME(S) AND ADDRESS(ES) Rome Laboratory (OCPA) 25 Electronic Pky Griffiss AFB NY 13441-4515				10. SPONSORING/MONITORING AGENCY REPORT NUMBER RL-TR-95-101	
11. SUPPLEMENTARY NOTES Rome Laboratory Project Engineer: Steven T. Johns/OCPA/(315) 330-4456					
12a. DISTRIBUTION/AVAILABILITY STATEMENT Approved for public release; distribution unlimited.				12b. DISTRIBUTION CODE	
13. ABSTRACT (Maximum 200 words) Solid state laser based on Cr:YAG and Cr:Forsterite have been investigated. Self mode-locking has been achieved in both systems with a limited tuning range in the Cr:YAG system. Nanocrystals of Cr:Foresterite suspended in an index-matching polymer have been produced and spun onto a glass slide. The 1 um thick layer has produced a significant amount of fluorescent emission but low loss waveguides were impossible to fabricate due to surface imperfections. A similar waveguide based on evanescent wave coupling into the Cr:Forsterite polymer has been built and tested.					
14. SUBJECT TERMS Cr:Forsterite, Cr:YAG, Laser, Modelocking, Waveguides				15. NUMBER OF PAGES 20	
				16. PRICE CODE	
17. SECURITY CLASSIFICATION OF REPORT UNCLASSIFIED		18. SECURITY CLASSIFICATION OF THIS PAGE UNCLASSIFIED		19. SECURITY CLASSIFICATION OF ABSTRACT UNCLASSIFIED	
				20. LIMITATION OF ABSTRACT U/L	

Final Report

Contract F30602-94-C-0030

Modelocking and Waveguide Amplifiers Using Cr:Forsterite and Cr:YAG

Table of Contents

1. Introduction	Page 1
2. Laser Research Results	Page 1
2.1 Thermal Transfer Improvements	Page 2
2.2 Cr:YAG Modelocking Attempts	Page 3
3. Thin Film Amplifier Research	Page 4
4. Conclusion	Page 6

Accession For	
NTIS CRA&I	<input checked="" type="checkbox"/>
DTIC TAB	<input type="checkbox"/>
Unannounced	<input type="checkbox"/>
Justification _____	
By _____	
Distribution /	
Availability Codes	
Dist	Avail and/or Special
A-1	

Final Report

Contract F30602-94-C-0030

Modelocking and Waveguide Amplifiers Using Cr:Forsterite and Cr:YAG

Clifford R. Pollock
School of Electrical Engineering
Cornell University
Ithaca, New York 14853
607-255-5032; email:cpollock@ee.cornell.edu

1. Introduction

Two initiatives were begun in this effort. First, we attempted to transfer the technology of modelocking a Cr:YAG laser to the Rome Labs team, and second, we began investigating new forms of waveguide amplifiers based on index matched nanocrystals of Cr:forsterite and Cr:YAG.

In the modelocking effort, we successfully demonstrated the first Kerr-lens modelocking of a Cr:YAG laser in our lab at Cornell. Over the period of this contract we worked with the staff at Rome Labs to transfer the techniques for modelocking to their laser. We interacted with Steve Johns, Mark Krol, and Mike Hayduk at Rome Labs in the construction of a similar laser. Pollock made several trips to Rome Labs during the year to help get the Cr:YAG laser operating in the cw mode. While there, continuous wave powers of over one half watt of power were developed from the Cr:YAG laser, and subsequently the Rome Lab team was able to increase the power to over one watt. Following the methods described by Pollock's graduate students and their publications, the Rome Labs members have attempted to modelock the Cr:YAG laser, but have as yet had no success. Steve Johns and Mike Hayduk came to Cornell in April 1994 to see the modelocked laser and to discuss with graduate student Alphan Sennaroglu different techniques for modelocking.

In the thin film amplifier work, graduate student Duane Barber has been investigating the emission properties of thin films made from powder composites of Cr:forsterite, and Cr:YAG. The composite films consist of nanocrystals of Cr-doped particles suspended in a refractive index-matching polymer, spun onto a glass slide. The film thicknesses are one the order of one micron. Even with such a thin sample, Barber has observed significant fluorescent emission from the films, and can characterize their emission lifetime as well. The passive loss of these waveguides was determined to be approximately 6 dB/cm.

2.0 Laser Research

A schematic of Cr:YAG laser cavity is shown below in Fig. 1. The crystal is located at the focus of a z-folded optical resonator. The optical cavity design is relatively straightforward. The critical aspects of the laser are the temperature control of the crystal, and

the optical system used to couple the pump beam into the laser crystal. The crystal in all systems we worked with was mounted on a thermoelectric cooler so that the temperature could be actively maintained below room temperature. We found performance improved with both host materials (forsterite and YAG) as the temperature decreased, but that below about 3 C the optical surfaces became fogged with condensed water from the air. We compromised between cooling the crystal for better power and yet not fogging the crystal surface by operating with crystal temperatures in the 8-12 °C range.

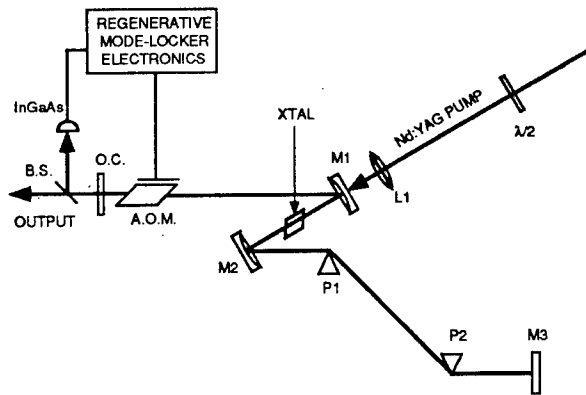

Fig. 1. Schematic of the modelocked solid state laser.

2.1 Thermal transfer improvements

One of our key discoveries we made this year was that the transverse size of the laser crystal could be reduced, with a dramatic increase in the laser output power. This was discovered by accident. We inadvertently damaged the face of a Cr:forsterite crystal with dimensions 5 x 5 x 20 mm. We sliced the crystal into four pieces, each 2 x 2 x 20 mm, and found that the damage was localized to only one piece. Using one of the remaining sound crystal pieces, we constructed a laser, and found the output power to be almost double that of previous results. We believe the reason for this is due to the reduced path that heat must flow to leave the crystal. The total thermal resistance between the pumped region of the crystal and the copper heat sink is reduced by approximately a factor of four with the smaller dimensions. Therefore the pumped region can operate at a cooler temperature while being pumped at the same powers we used for the large crystal. A second benefit of this discovery is that we can now make several lasers from one purchased crystal, and get better performance at the same time. While our initial results were obtained from using forsterite, they should be directly transferable to the Cr:YAG system. We are pursuing that at the present time.

A recent result we are just beginning to test is the use of indium solder to create the thermal bond between the copper heat sink and the laser crystal. Typically we have placed 0.005" indium foil between the crystal and copper heat sink to act as a compliant thermal transfer medium to allow for better contact between the crystal and heat sink, and to provide some ability for the crystal to expand without danger of cracking. The problem with the indium foil is that it tends to form an oxide on the surface, and the bond between the crystal and indium is not intimate. This dramatically increases the thermal resistance of the interface. We have recently mastered the art of soldering the crystal directly to

the copper heat sink using a hot plate, some soldering flux ("Stay-Clean"), and a clean laser crystal. Initial thermal measurements show that the heat transfer is approximately a factor of 2 better than our standard indium foil technique. Figure 2 shows preliminary data on the crystal cooling efficiency. We are in the process of testing this method for laser operation. If it works as well as anticipated, we may see a further increase in laser performance when operated as before (at 5 C), or we may find that we can eliminate the need to a TE cooler on the laser. Either result would be an advance.

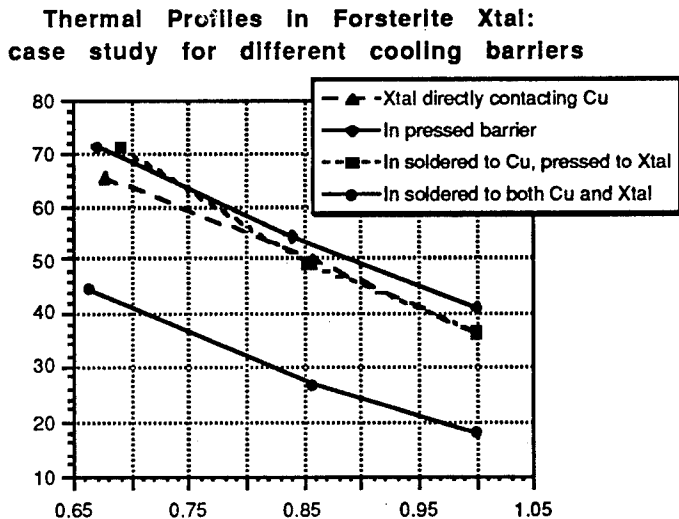

Fig. 2. Thermal energy transfer from a forsterite crystal using four different bonding techniques. The soldering technique is dramatically better for heat removal.

2.2 Cr:YAG Modelocking Attempts

We had found in previous work that modelocking the Cr:YAG laser was impossible when we operated at a wavelength near the peak of the output power curve for the laser (1.45 μm), which happens to coincide with the strong atmospheric absorption due to water. The absorption primarily introduces a strong dispersion into the cavity which cannot be compensated or overcome with bulk optics. Modelocking was only possible at wavelengths greater than 1.5 μm . However, in interacting with the Rome Labs group, we found that their crystal would not tune out to wavelengths much beyond 1.52 μm , which made the prospects for modelocking poor. Several attempts were made to fix this problem, including replacing all the optics in their cavity with mirrors we had successfully used here at Cornell. Subsequent to one of Pollock's visits to Rome Labs, it was determined that the absorption of the Cr:YAG crystal at the pump wavelength was significantly less than that observed by the Cornell group. A new crystal was obtained with specifications that the small signal absorption of the pump power exceed certain values.

The new crystal was tested, and initially there was not much improvement over the original tuning range. However, after much iteration, replacement of mirrors, new tuning elements, etc., the Rome Labs group was able to get the new crystal to tune out to beyond 1.57 μm . This problem seems to be solved.

After several trips to Rome by Pollock, there still has been no successful modelocking of the Cr:YAG laser. However, concurrent work on Cr:forsterite at Cornell by graduate student Martin Jaspin finally led to the discovery of a successful, and repeatable, method to modelock these lasers. The technique critically relies on observing the spatial mode structure of the laser. As the spacing between the two curved mirrors is changed, the normal Gaussian shaped mode begins to acquire significant higher-order mode structure. When these higher order spatial modes appear, the laser will generally modelock, with 50 fsec pulses. Fig. 3 shows the amplitude autocorrelation of the Cr:forsterite laser during modelocking, and Figure 4 shows the output spectrum. The output of this laser is very quiet and reliable. We are in the process of transferring this technology to Rome Labs for the Cr:YAG laser research.

Modelocked Forsterite Autocorrelation

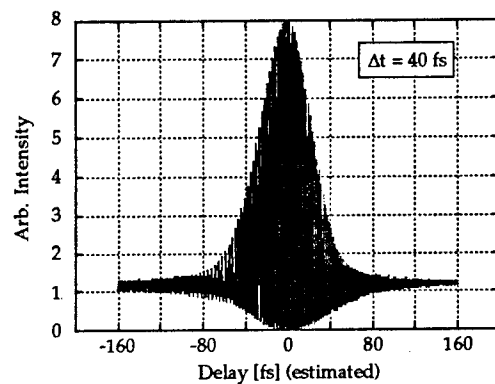

Fig. 3. Autocorrelation of the modelocked output of the Cr:forsterite modelocked laser.

Modelocked Forsterite Spectrum

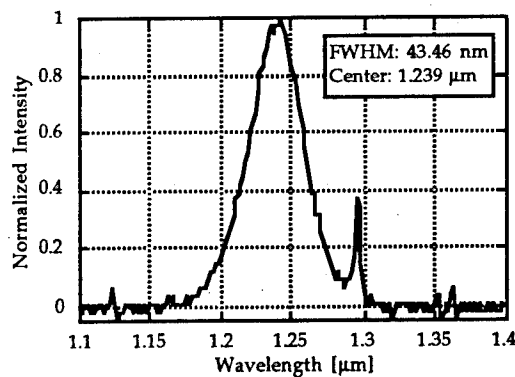

Fig. 4. Spectral content of the modelocked Cr:Forsterite laser. (The spectrum shown here does not correspond to the temporal pulse shown in Fig. 3).

3. Thin Film Amplifier Research

Our previous work on thin film amplifiers relied on depositing films of Cr:forsterite on glass using a sol-gel deposition technique which involved spinning on the sol, baking it dry at 600 C, then spinning on another coat, etc. After ten coatings, the film could be

built up to approximately 1 μm in thickness, but unfortunately it was heavily fractured due to residual stress caused by the difference in thermal expansion coefficients of the thin film material and the glass substrate. To counter this, we began exploring the use of nanocrystals embedded in an index matching matrix made of polymer or glass. Forsterite particles approximately 50-150 nm in diameter were formed by sintering a sol under the proper pressure and temperature conditions. Powder samples were measured for absorption, emission, and emission lifetime, and were found to be consistent with bulk Cr:forsterite.

Graduate student Duane Barber collaborated with Prof. Chris Ober of the Material Science and Engineering Department, and Prof. Jim Burlitch of Chemistry, to do the index matching of these particles in polymer and glass hosts. The first work was done using nanocrystals of Cr-doped forsterite suspended in a refractive index-matching polymer, and spun onto a glass slide. The films he obtained were approximately 1 μm thick. Even with such a thin sample, Barber has observed significant fluorescent emission from the films, and can characterize their emission lifetime as well. A sample of the emission obtained from a Cr:forsterite sample is shown in Fig. 5. The data is notable due to the lack of significant emission from Cr^{3+} , even though green light from an argon ion laser is used to excite the sample. The emission peak shown is characteristic of the Cr^{4+} transition.

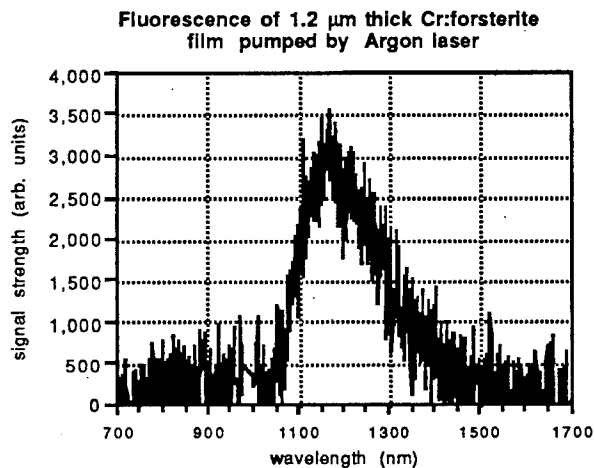

Fig. 5. Spectral emission profile from a Cr:forsterite thin film, pumped by an argon laser

Because forsterite is a biaxial crystal, it is impossible to perfectly index match it in an isotropic medium. Therefore, we can expect that there will be scattering losses associated with the randomly oriented particles in a index-matched host medium. The Rayleigh scattering due to these particles (assuming the particle density is below the percolation point) is given by

$$\frac{P_{scat}}{P_0} = \rho \frac{(n' - n)^2 V^2}{n^2 \lambda^4} 24\pi^4$$

where ρ is the number of nanocrystals per unit volume, n' is the index of refraction of the scatterers, n is the index of refraction of the host material, V is the volume of a single scatterer, and λ is the wavelength of light. Making the particle size small reduces the

loss due to scattering. Assuming a power gain as high as 50% per cm for forsterite, the trade-off between loss and gain can be evaluated. We have numerically determined that particles on the order of 100-200 nm are the optimum size for this system.

The surfaces of the spun-on polymer films were found to be much too rough to create a low loss waveguide. Losses on the order of 10 dB/cm were measured at a wavelength of 633 nm. Furthermore, once the polymer refractive index matrix had been properly processed to create the nanocrystals, the one micron thickness was too thin to conveniently couple energy into it. With such a high excess loss due to the surface, it is unlikely that we would be able to generate net gain from a thin-film waveguide amplifier. Based on this and discussions with Prof. Chris Ober of the Material Science and Engineering Department, we decided to try building an evanescently coupled amplifier based on nanoparticle composites. A thin film waveguide has been constructed using $\text{SiO}_2/\text{TiO}_2$ glass on a glass waveguide. This waveguide is approximately $1\ \mu\text{m}$ thick, and can support one mode. On top of this waveguide, we coated a $10\ \mu\text{m}$ thick layer of refractive index matched polymer filled with Cr:forsterite nanoparticles. The evanescent wave of the the guided mode couples to the gain medium, but does not extend far enough into the gain medium to 'see' the rough top surface. Initial measurements of the scattering loss from this structure show that it falls in the 5-8 dB range. We attribute some of this to input scattering at the end-fire input and exit planes of the waveguide. We have not yet been able to identify the source of the rest of the loss. A plot of the loss data, obtained by measuring the scattered light from above the waveguide as it propagates along the waveguide, is shown in Fig. 6.

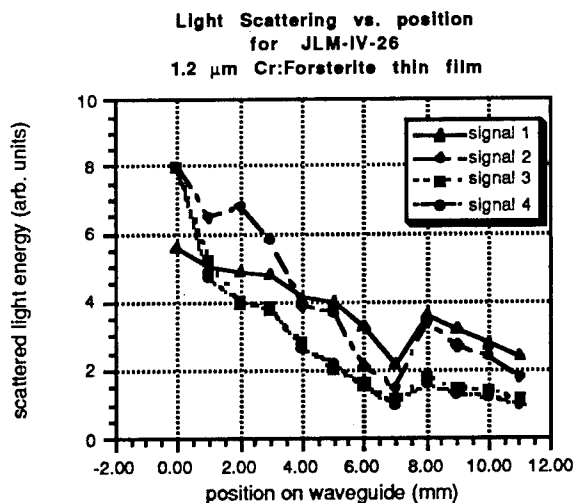

Fig. 5. Plot of the amount of light left in the thin-film waveguide as a function of distance along the waveguide.

4. Conclusion

In this work, we have interacted closely with the group at Rome Labs to get a Cr:YAG laser operational and modelocked. While we have obtained good operating power from this laser, we were unable to successfully transfer the techniques of femtosecond modelocking to the Labs, but we were able to transfer the technology for operating and maintaining

power cw lasers based on Cr:YAG.

The thin film waveguide research demonstrated the concept of using optical nanocomposites in real devices. This has, to our knowledge, never been tried before. Our first results demonstrated that waveguiding can be achieved in nanocomposite materials, and that the losses are not unreasonable for a first effort.

Rome Laboratory
Customer Satisfaction Survey

RL-TR-_____

Please complete this survey, and mail to RL/IMPS,
26 Electronic Pky, Griffiss AFB NY 13441-4514. Your assessment and
feedback regarding this technical report will allow Rome Laboratory
to have a vehicle to continuously improve our methods of research,
publication, and customer satisfaction. Your assistance is greatly
appreciated.
Thank You

Organization Name: _____ (Optional)

Organization POC: _____ (Optional)

Address: _____

1. On a scale of 1 to 5 how would you rate the technology
developed under this research?

5-Extremely Useful 1-Not Useful/Wasteful

Rating _____

Please use the space below to comment on your rating. Please
suggest improvements. Use the back of this sheet if necessary.

2. Do any specific areas of the report stand out as exceptional?

Yes ___ No _____

If yes, please identify the area(s), and comment on what
aspects make them "stand out."

3. Do any specific areas of the report stand out as inferior?

Yes___ No___

If yes, please identify the area(s), and comment on what aspects make them "stand out."

4. Please utilize the space below to comment on any other aspects of the report. Comments on both technical content and reporting format are desired.

MISSION
OF
ROME LABORATORY

Mission. The mission of Rome Laboratory is to advance the science and technologies of command, control, communications and intelligence and to transition them into systems to meet customer needs. To achieve this, Rome Lab:

- a. Conducts vigorous research, development and test programs in all applicable technologies;
- b. Transitions technology to current and future systems to improve operational capability, readiness, and supportability;
- c. Provides a full range of technical support to Air Force Materiel Command product centers and other Air Force organizations;
- d. Promotes transfer of technology to the private sector;
- e. Maintains leading edge technological expertise in the areas of surveillance, communications, command and control, intelligence, reliability science, electro-magnetic technology, photonics, signal processing, and computational science.

The thrust areas of technical competence include: Surveillance, Communications, Command and Control, Intelligence, Signal Processing, Computer Science and Technology, Electromagnetic Technology, Photonics and Reliability Sciences.