

# NATIONAL ADVISORY COMMITTEE FOR AERONAUTICS

REPORT 967

## ELASTIC AND PLASTIC BUCKLING OF SIMPLY SUPPORTED SOLID-CORE SANDWICH PLATES IN COMPRESSION

By PAUL SEIDE and ELBRIDGE Z. STOWELL

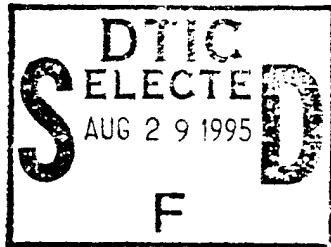

AIR FORCE RESEARCH SECTION  
SCIENTIFIC DIVISION  
AERONAUTICAL ENGINEERING DEPARTMENT  
OFFICE OF THE SECRETARY OF THE AIR FORCE  
WASHINGTON, D. C.

JAN 25 1951

DISTRIBUTION STATEMENT A  
Approved for public release  
Distribution Unlimited

1950

For sale by the Superintendent of Documents, U. S. Government Printing Office, Washington 25, D. C. Yearly subscription, \$3.50; foreign, \$4.00; single copy price varies according to size. Price 70 cents

19950825 114

DTIC QUALITY INSPECTED 3

U3628

# AERONAUTIC SYMBOLS

## 1. FUNDAMENTAL AND DERIVED UNITS

	Symbol	Metric		English	
		Unit	Abbreviation	Unit	Abbreviation
Length.....	<i>l</i>	meter.....	m	foot (or mile).....	ft (or mi)
Time.....	<i>t</i>	second.....	s	second (or hour).....	sec (or hr)
Force.....	<i>F</i>	weight of 1 kilogram.....	kg	weight of 1 pound.....	lb
Power.....	<i>P</i>	horsepower (metric).....		horsepower.....	hp
Speed.....	<i>V</i>	kilometers per hour.....	kph	miles per hour.....	mph
		meters per second.....	mps	feet per second.....	fps

## 2. GENERAL SYMBOLS

<i>W</i>	Weight = $mg$	<i>v</i>	Kinematic viscosity
<i>g</i>	Standard acceleration of gravity = 9.80665 m/s <sup>2</sup> or 32.1740 ft/sec <sup>2</sup>	$\rho$	Density (mass per unit volume)
<i>m</i>	Mass = $\frac{W}{g}$		Standard density of dry air, 0.12497 kg-m <sup>-3</sup> -s <sup>2</sup> at 15° C and 760 mm; or 0.002378 lb-ft <sup>-3</sup> sec <sup>2</sup>
<i>I</i>	Moment of inertia = $mk^2$ . (Indicate axis of radius of gyration <i>k</i> by proper subscript.)		Specific weight of "standard" air, 1.2255 kg/m <sup>3</sup> or 0.07651 lb/cu ft
$\mu$	Coefficient of viscosity		

## 3. AERODYNAMIC SYMBOLS

<i>S</i>	Area	<i>i<sub>w</sub></i>	Angle of setting of wings (relative to thrust line)
<i>S<sub>w</sub></i>	Area of wing	<i>i<sub>t</sub></i>	Angle of stabilizer setting (relative to thrust line)
<i>G</i>	Gap	<i>Q</i>	Resultant moment
<i>b</i>	Span	$\Omega$	Resultant angular velocity
<i>c</i>	Chord	<i>R</i>	Reynolds number, $\rho \frac{Vl}{\mu}$ where <i>l</i> is a linear dimension (e.g., for an airfoil of 1.0 ft chord, 100 mph, standard pressure at 15° C, the corresponding Reynolds number is 935,400; or for an airfoil of 1.0 m chord, 100 mps, the corresponding Reynolds number is 6,865,000)
<i>A</i>	Aspect ratio, $\frac{b^2}{S}$	$\alpha$	Angle of attack
<i>V</i>	True air speed	$\epsilon$	Angle of downwash
<i>q</i>	Dynamic pressure, $\frac{1}{2} \rho V^2$	$\alpha_0$	Angle of attack, infinite aspect ratio
<i>L</i>	Lift, absolute coefficient $C_L = \frac{L}{qS}$	$\alpha_i$	Angle of attack, induced
<i>D</i>	Drag, absolute coefficient $C_D = \frac{D}{qS}$	$\alpha_a$	Angle of attack, absolute (measured from zero-lift position)
<i>D<sub>0</sub></i>	Profile drag, absolute coefficient $C_{D_0} = \frac{D_0}{qS}$	$\gamma$	Flight-path angle
<i>D<sub>i</sub></i>	Induced drag, absolute coefficient $C_{D_i} = \frac{D_i}{qS}$		
<i>D<sub>p</sub></i>	Parasite drag, absolute coefficient $C_{D_p} = \frac{D_p}{qS}$		
<i>C</i>	Cross-wind force, absolute coefficient $C_C = \frac{C}{qS}$		

---

---

# REPORT 967

---

## ELASTIC AND PLASTIC BUCKLING OF SIMPLY SUPPORTED SOLID-CORE SANDWICH PLATES IN COMPRESSION

By PAUL SEIDE and ELBRIDGE Z. STOWELL

Langley Aeronautical Laboratory  
Langley Air Force Base, Va.

---

---

1

<b>Accession For</b>	
NTIS CRA&I	<input checked="" type="checkbox"/>
DTIC TAB	<input type="checkbox"/>
Unannounced	<input type="checkbox"/>
Justification .....	
<b>By</b> .....	
<b>Distribution /</b> .....	
Availability Codes	
<b>Dist</b>	Avail and/or Special
A-1	

# National Advisory Committee for Aeronautics

*Headquarters, 1724 F Street NW., Washington 25, D. C.*

Created by act of Congress approved March 3, 1915, for the supervision and direction of the scientific study of the problems of flight (U. S. Code, title 50, sec. 15). Its membership was increased from 12 to 15 by act approved March 2, 1929, and to 17 by act approved May 25, 1948. The members are appointed by the President, and serve as such without compensation.

JEROME C. HUNSAKER, Sc. D., Massachusetts Institute of Technology, *Chairman*

ALEXANDER WETMORE, Sc. D., Secretary, Smithsonian Institution, *Vice Chairman*

DETLEV W. BRONK, Ph. D., President, Johns Hopkins University.

JOHN H. CASSADY, Vice Admiral, United States Navy, Deputy Chief of Naval Operations.

EDWARD U. CONDON, Ph. D., Director, National Bureau of Standards.

HON. THOMAS W. S. DAVIS, Assistant Secretary of Commerce.

JAMES H. DOOLITTLE, Sc. D., Vice President, Shell Union Oil Corp.

R. M. HAZEN, B. S., Director of Engineering, Allison Division, General Motors Corp.

WILLIAM LITTLEWOOD, M. E., Vice President, Engineering, American Airlines, Inc.

THEODORE C. LONNQUEST, Rear Admiral, United States Navy, Deputy and Assistant Chief of the Bureau of Aeronautics.

DONALD L. PUTT, Major General, United States Air Force, Director of Research and Development, Office of the Chief of Staff, Matériel.

ARTHUR E. RAYMOND, Sc. D., Vice President, Engineering, Douglas Aircraft Co., Inc.

FRANCIS W. REICHELDERFER, Sc. D., Chief, United States Weather Bureau.

HON. DELOS W. RENTZEL, Administrator of Civil Aeronautics, Department of Commerce.

HOYT S. VANDENBERG, General, Chief of Staff, United States Air Force.

WILLIAM WEBSTER, M. S., Chairman, Research and Development Board, Department of Defense.

THEODORE P. WRIGHT, Sc. D., Vice President for Research, Cornell University.

HUGH L. DRYDEN, Ph. D., *Director*

JOHN W. CROWLEY, JR., B. S., *Associate Director for Research*

JOHN F. VICTORY, LL. D., *Executive Secretary*

E. H. CHAMBERLIN, *Executive Officer*

HENRY J. REID, D. Eng., Director, Langley Aeronautical Laboratory, Langley Air Force Base, Va.

SMITH J. DEFRAANCE, B. S., Director Ames Aeronautical Laboratory, Moffett Field, Calif.

EDWARD R. SHARP, Sc. D., Director, Lewis Flight Propulsion Laboratory, Cleveland Airport, Cleveland, Ohio

## TECHNICAL COMMITTEES

AERODYNAMICS

POWER PLANTS FOR AIRCRAFT

AIRCRAFT CONSTRUCTION

OPERATING PROBLEMS

INDUSTRY CONSULTING

*Coordination of Research Needs of Military and Civil Aviation*

*Preparation of Research Programs*

*Allocation of Problems*

*Prevention of Duplication*

*Consideration of Inventions*

LANGLEY AERONAUTICAL LABORATORY,  
Langley Air Force Base, Va.

LEWIS FLIGHT PROPULSION LABORATORY,  
Cleveland Airport, Cleveland, Ohio

AMES AERONAUTICAL LABORATORY,  
Moffett Field, Calif.

*Conduct, under unified control, for all agencies, of scientific research on the fundamental problems of flight*

OFFICE OF AERONAUTICAL INTELLIGENCE,  
Washington, D. C.

*Collection, classification, compilation, and dissemination of scientific and technical information on aeronautics*

## REPORT 967

# ELASTIC AND PLASTIC BUCKLING OF SIMPLY SUPPORTED SOLID-CORE SANDWICH PLATES IN COMPRESSION

By PAUL SEIDE and ELBRIDGE Z. STOWELL

### SUMMARY

A solution is presented for the problem of the compressive buckling of simply supported, flat, rectangular, solid-core sandwich plates stressed either in the elastic range or in the plastic range. Charts for the analysis of long sandwich plates are presented for plates having face materials of 24S-T3 aluminum alloy, 75S-T6 Alclad aluminum alloy, and stainless steel.

A comparison of computed and experimental buckling stresses of square solid-core sandwich plates indicates fair agreement between theory and experiment.

### INTRODUCTION

The necessary condition that the wing surfaces of modern high-speed aircraft remain smooth under high loads has led to the use of the sandwich plate as a substitute for sheet-stringer construction. Sandwich plates consist of two thin sheets of metal separated by a low-density, low-stiffness core which, though contributing little to the strength of the plate, serves to increase tremendously the flexural stiffness of the load-carrying faces. The increase in flexural stiffness is somewhat offset, however, by deflections due to shear which become appreciable because of the low stiffness of the core.

Several papers, which extend ordinary plate theory to take into account deflections due to shear, have appeared recently in this country. The extension is made approximately in reference 1 by means of the assumption that any line in the core that is initially straight and normal to the middle surface of the core will remain straight after deformation but will deviate from the normal to the deformed middle surface by an amount that is proportional to the slope of the plate surface, the proportionality factor being the same throughout the plate. The theory is used to obtain approximate criteria for the compressive buckling of plates with various edge-support conditions. The criteria are corrected for the effects of plasticity by replacing the Young's modulus of the face material everywhere it appears in the buckling formulas by a reduced modulus, this method of correction being partly justified by the consideration of its theoretical effectiveness in connection with the plastic buckling of simply supported sandwich columns. Reference 2 presents a small-deflection theory for elastic bending and buckling of orthotropic sandwich plates which considers shear deformations in a more refined manner. Reference 3

presents a large-deflection analysis of elastic isotropic sandwich plates and reduces the equations to small-deflection form to solve the problem of the compressive buckling of simply supported sandwich plates. The theories of references 2 and 3 can be shown to reduce to that of reference 1 in the case of the problem of the compressive buckling of simply supported plates.

In the present report the theory of reference 2 is applied to the problem of the compressive buckling of simply supported solid-core sandwich plates. The particular sandwich considered (fig. 1) is one for which face-parallel stresses in the core may be neglected so that all the applied load is carried by the faces. Furthermore, the faces are assumed to be very thin compared with the core. The stability criterion obtained is similar to those given in references 1 and 3. The theory is also extended to the plastic range in much the same manner as was done in reference 4 for solid plates and is used to determine the plastic compressive buckling stress of simply supported solid-core sandwich plates. Charts for the analysis of long sandwich plates stressed in the elastic range or in the plastic range are presented for plates having face materials of 24S-T3 aluminum alloy, 75S-T6 Alclad aluminum alloy, and stainless steel.

The theory is checked by a comparison of computed and experimental results for square sandwich plates with 24S-T Alclad aluminum-alloy faces and end-grain balsa cores. The experimental results were obtained from reference 5. Fair agreement is found between theory and experiment.

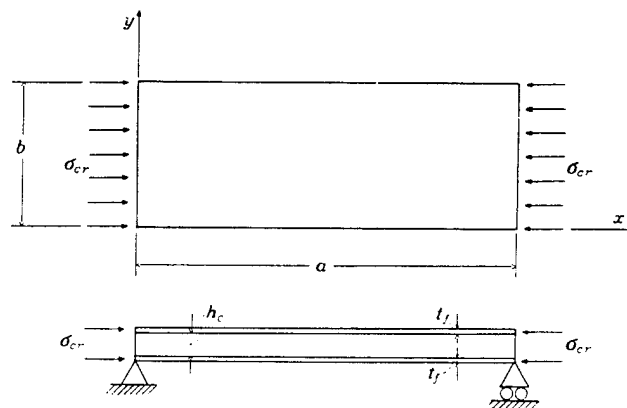

FIGURE 1.—Simply supported solid-core sandwich plate under compression.

## SYMBOLS

$x, y$	coordinate axes (fig. 1)
$E_f$	Young's modulus for face material
$E_s$	secant modulus for face material
$E_T$	tangent modulus for face material
$C_1 = \frac{1}{4} + \frac{3}{4} \frac{E_T}{E_s}$	
$\psi = \frac{E_s}{E_f}$	
$\mu_f$	Poisson's ratio for face material
$G_c$	shear modulus of core material
$t_f$	face thickness
$h_c$	core thickness
$D$	flexural stiffness per unit width of sandwich plate $\left( \frac{E_f t_f (h_c + t_f)^2}{2(1 - \mu_f^2)} \right)$
$B$	flexural stiffness per unit width of sandwich beam $\left( \frac{E_f t_f (h_c + t_f)^2}{2} \right)$
$a$	plate length
$b$	plate width
$\beta$	plate aspect ratio ( $a/b$ )
$\sigma_{cr}$	buckling stress
$k$	elastic-buckling-stress coefficient $\left( \frac{2b^2 \sigma_{cr} t_f}{\pi^2 D} \right)$
$k'$	elastic-buckling-stress coefficient based upon $\mu_f = \frac{1}{2} \left( \frac{3}{2} \frac{b^2 \sigma_{cr} t_f}{\pi^2 B} \right)$
$k_{pi}$	plastic-buckling-stress coefficient $\left( \frac{2b^2 \sigma_{cr} t_f}{\pi^2 D} \right)$
$k'_{pi}$	plastic-buckling-stress coefficient based upon $\mu_f = \frac{1}{2} \left( \frac{3}{2} \frac{b^2 \sigma_{cr} t_f}{\pi^2 B} \right)$
$r$	core shear-stiffness parameter for sandwich plate $\left( \frac{\pi^2 D}{b^2 G_c h_c} \right)$
$s$	core shear-stiffness parameter for sandwich column $\left( \frac{\pi^2 B'}{b^2 G_c h_c} \right)$
$m$	number of half-waves in buckled plate deflection surface in direction of loading

## RESULTS AND DISCUSSION

Compressive buckling formulas for simply supported flat rectangular solid-core sandwich plates are derived in the appendixes for buckling in either the elastic range or in the plastic range. The equation for compressive buckling in the elastic range is obtained in appendix A by use of the theory developed in reference 2. The theory is modified in appendix B to obtain the equation for compressive buckling in the plastic range.

**Elastic range.**—For finite plates the buckling-stress coefficient is given by equation (A7) of appendix A as follows:

$$k = \frac{\left( \frac{m}{\beta} + \frac{\beta}{m} \right)^2}{1 + r \left( 1 + \frac{m^2}{\beta^2} \right)} \quad (1)$$

Consecutive integral values of  $m$  are substituted into equation (1) until a minimum value of the buckling coefficient is obtained for given values of  $\beta$  and  $r$ . For infinite plates the coefficient reduces to

$$k = \frac{4}{(1+r)^2} \quad (r \leq 1) \quad (2)$$

and

$$k = \frac{1}{r} \quad (r \geq 1) \quad (3)$$

When the core shear stiffness is infinite ( $r=0$ ), equations (1) and (2) reduce to the well-known buckling criteria for isotropic plates with deflections due to shear neglected.

Equations (1) to (3) are presented graphically in figures 2 and 3. Figure 2 shows that the effect of finite core shear stiffness is not only to decrease the buckling stress but also to increase the number of half-waves in the buckled plate. If the core shear-stiffness parameter is equal to or less than 1.0, the wave length of buckle becomes infinitely small, in

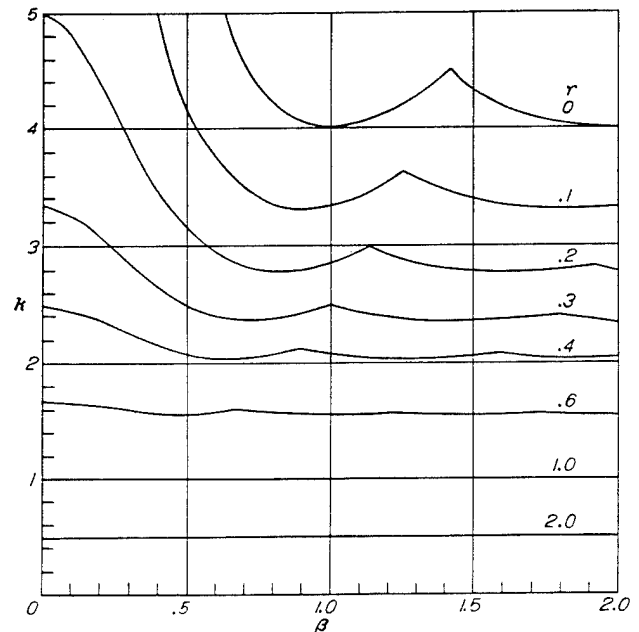

FIGURE 2.—Compressive-buckling coefficients for finite solid-core sandwich plates stressed in the elastic range.

which case the restraint to buckling offered by the side supports has no effect. The buckling-stress coefficient is then independent of the plate aspect ratio  $\beta$  and is determined by the shear strength of the core.

**Plastic range.**—When the buckling stress is in the plastic range the buckling coefficients are given by the appropriate one of equations (B10) to (B13) of appendix B. Since the buckling coefficient is given by these equations as a function of the buckling stress, a graphical method must be used to analyze a given plate. The buckling coefficient given by equations (B10) to (B13) is defined as

$$k'_{pi} = \frac{3}{2} \frac{b^2 \sigma_{cr} t_f}{\pi^2 B} \quad (4)$$

Equation (4) can be rearranged to give

$$\frac{\pi^2 B}{b^2 t_f} = \frac{3}{2} \frac{\sigma_{cr}}{k'_{pi}} \quad (5)$$

so that  $\frac{\pi^2 B}{b^2 t_f}$  is now given in terms of the buckling stress, the shear-stiffness parameter  $\frac{\pi^2 B}{b^2 G_c h_c}$  and the plate aspect ratio  $\beta$ , all of which are contained in  $k'_{pi}$ . For a given value of  $\beta$ , curves of  $\frac{\pi^2 B}{b^2 t_f}$  against buckling stress can be plotted for various values of the shear-stiffness parameter  $\frac{\pi^2 B}{b^2 G_c h_c}$ . Then for a given plate,  $\frac{\pi^2 B}{b^2 t_f}$  and  $\frac{\pi^2 B}{b^2 G_c h_c}$  are defined by the plate dimensions and material properties and the buckling stress may then be obtained from the appropriate curve.

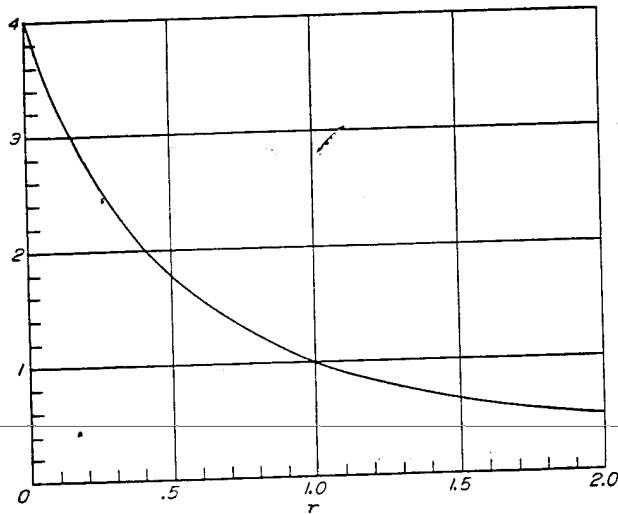

FIGURE 3.—Compressive-buckling coefficients for infinitely long solid-core sandwich plates stressed in the elastic range.  $k = \frac{4}{(1+r)^2}$  for  $r \leq 1$ ;  $k = \frac{1}{r}$  for  $r \geq 1$ .

Since equations (B10) to (B13) are valid only for plates with a Poisson's ratio of  $\frac{1}{2}$ , the buckling stresses computed by the foregoing method from those equations are in error for plates having other Poisson's ratios and must be corrected. The correction process used in the present report is the following: For a given plate, the plastic buckling stress based on a Poisson's ratio of  $\frac{1}{2}$  is computed by the foregoing method. The buckling stress for a perfectly elastic plate is also computed by using the appropriate one of equations (B14) to (B16) which are also based upon a Poisson's ratio of  $\frac{1}{2}$ . It is assumed that for given values of  $\frac{\pi^2 B}{b^2 t_f}$  and  $\frac{\pi^2 B}{b^2 G_c h_c}$  the ratio of the plastic and elastic stresses is independent of Poisson's ratio. Then for any other value of Poisson's ratio the corrected buckling stress is given by:

$$\begin{aligned} \sigma_{cr} &= \eta \times \text{Elastic buckling stress for actual value of } \mu_f \\ &= \eta \frac{\pi^2 B}{2b^2 t_f} \frac{k}{1-\mu_f^2} \end{aligned} \quad (6)$$

where  $\eta$  is the ratio of the plastic and elastic buckling stresses computed on the basis of  $\mu_f = \frac{1}{2}$  and  $k$  is determined from equations (1) to (3) for finite plates as

$$k = \frac{\left(\frac{m}{\beta} + \frac{\beta}{m}\right)^2}{\frac{\pi^2 B}{b^2 G_c h_c} \left(1 + \frac{m^2}{1-\mu_f^2}\right)} \quad (7)$$

and for infinitely long plates as

$$k = \frac{4}{\left(\frac{\pi^2 B}{b^2 G_c h_c}\right)^2} \left(\frac{\pi^2 B}{b^2 G_c h_c} \leq 1-\mu_f^2\right) \quad (8)$$

$$k = \frac{1-\mu_f^2}{\left(\frac{\pi^2 B}{b^2 G_c h_c}\right)} \left(\frac{\pi^2 B}{b^2 G_c h_c} \geq 1-\mu_f^2\right) \quad (9)$$

Curves of  $\frac{\pi^2 B}{b^2 t_f}$  against the corrected buckling stress for various values of  $\frac{\pi^2 B}{b^2 G_c h_c}$  may now be drawn. Different sets of curves are obtained for different values of  $\mu_f$ .

Charts for the analysis of infinitely long sandwich plates were constructed by the foregoing method for face materials of 24S-T3 aluminum alloy, Alclad 75S-T6 aluminum alloy, and stainless steel and are presented, together with the typical

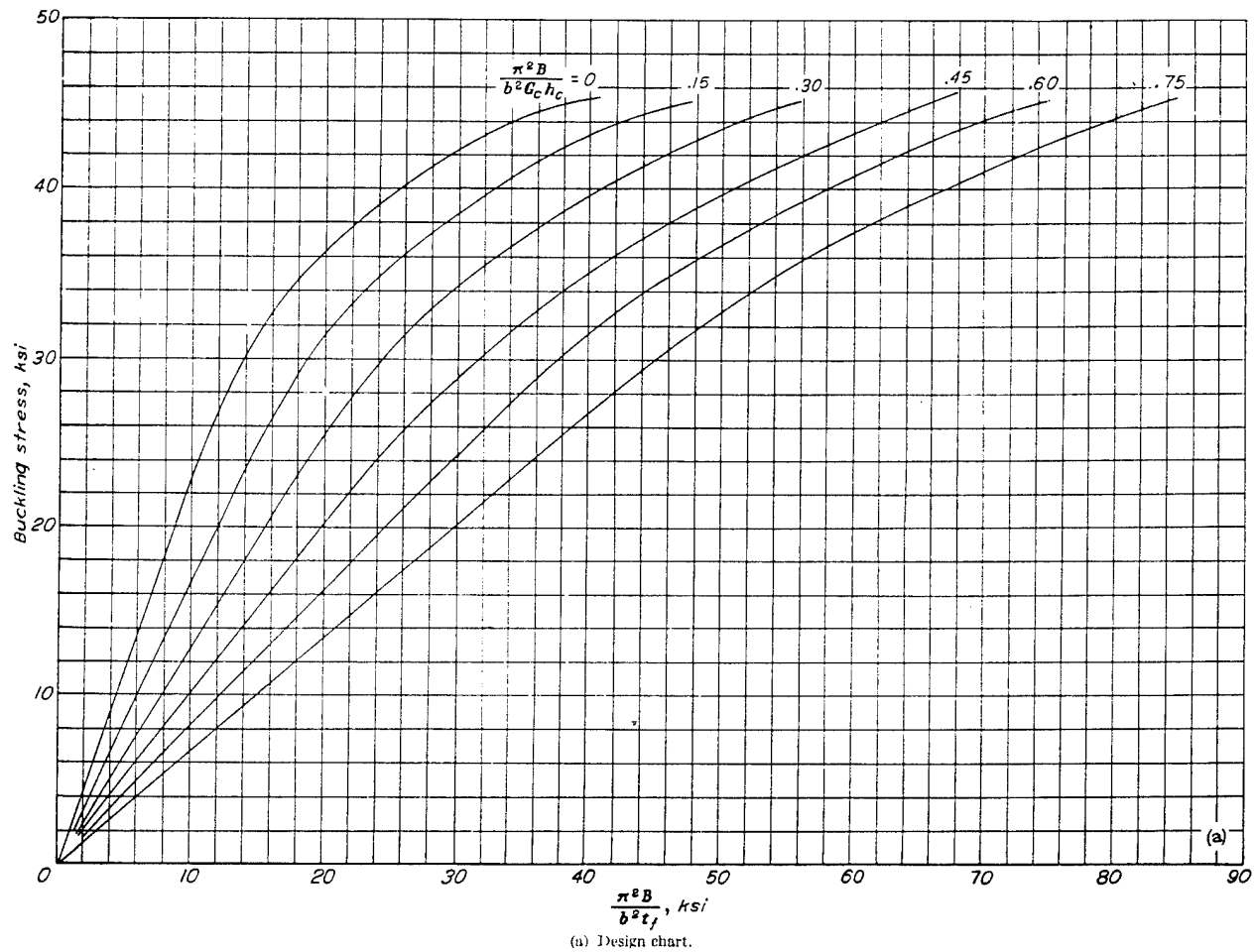

FIGURE 4.—Charts for long solid-core sandwich plates with 24S-T3 aluminum-alloy faces.  $\mu_f = \frac{1}{3}$ .

stress-strain curves on which they are based, as figures 4, 5, and 6, respectively. In each case  $\mu_f$  was taken as  $\frac{1}{3}$ . Since the equations used do not depend on the stress-strain curve itself but upon its shape as given by the curves of  $E_s/E_f$  and  $E_T/E_f$  as functions of stress (figs. 4(b), 5(b), and 6(b)), solid-core sandwich plates having faces of any material for which curves of  $E_s/E_f$  and  $E_T/E_f$  against stress are similar to those used may be analyzed by means of the corresponding chart.

The charts of figures 4, 5, and 6 for infinitely long sandwich plates may be used with little error for finite plates, the aspect ratios of which are greater than 3. An extension of the curves of figure 2 would indicate that in this range of aspect ratio the buckling coefficient is essentially given by that for the infinitely long plate, especially if the core shear stiffness is low.

**Comparison of theory and experiment.**—An experimental check of the equations derived in this report for the compressive buckling of simply supported solid-core sandwich plates was obtained by a comparison of computed and experimental buckling stresses of square plates having 24S-T Alclad aluminum-alloy faces and end-grain-balsa cores of various thicknesses (fig. 7). The experimental results were obtained from reference 5.

The computations involved in the determination of the theoretical stresses were shortened by using the typical stress-strain curve of figure 4(b) for 24S-T3 aluminum

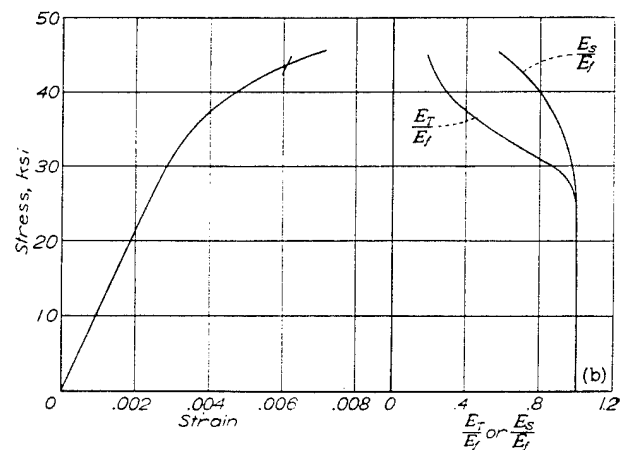

FIGURE 4.—Concluded.

alloy instead of the stress-strain curves presented in reference 5 for 24S-T Alclad aluminum-alloy sheet of various thicknesses. The stress-strain curve used is approximately the average of the actual stress-strain curves.

As indicated by figure 7 the agreement between computed and experimental stresses is fair, the computed stresses being on the average 8 percent higher than the experimental stresses. In individual cases, however, the deviation is as

## APPENDIX A

### DERIVATION OF COMPRESSIVE BUCKLING EQUATION FOR SIMPLY SUPPORTED SOLID-CORE SANDWICH PLATES STRESSED IN THE ELASTIC RANGE

The compressive buckling criterion for simply supported solid-core sandwich plates (fig. 1) stressed in the elastic range may be derived by means of equations (5a) to (6c) of reference 2. In the equations seven physical constants of sandwich plates (two Poisson's ratios, two flexural stiffnesses, a twisting stiffness, and two shear stiffnesses) must be specified. In order to determine the physical constants, the following assumptions are made in the present report:

1. The faces and core are isotropic.
2. Face-parallel stresses in the core may be neglected so that the applied loads are carried only by the faces.
3. Vertical shear forces are carried only by the core and are distributed uniformly across the thickness of the core.
4. The faces are assumed to be very thin compared to the core so that the variation of face-parallel stresses across the thickness of the faces may be neglected.

Under these assumptions the physical constants of solid-core sandwich plates are

$$\left. \begin{aligned} \mu_x = \mu_y = \mu_f \\ D_x = D_y = (1 + \mu_f) D_{xy} = \frac{E_f t_f (h_c + t_f)^2}{2} \\ D_{Q_x} = D_{Q_y} = G_c h_c \end{aligned} \right\} \quad (A1)$$

Equations (5a) to (6c) of reference 2 may then be written as

$$M_x = -D \left[ \frac{\partial}{\partial x} \left( \frac{\partial w}{\partial x} - \frac{Q_x}{G_c h_c} \right) + \mu_f \frac{\partial}{\partial y} \left( \frac{\partial w}{\partial y} - \frac{Q_y}{G_c h_c} \right) \right] \quad (A2a)$$

$$M_y = -D \left[ \frac{\partial}{\partial y} \left( \frac{\partial w}{\partial y} - \frac{Q_y}{G_c h_c} \right) + \mu_f \frac{\partial}{\partial x} \left( \frac{\partial w}{\partial x} - \frac{Q_x}{G_c h_c} \right) \right] \quad (A2b)$$

$$M_{xy} = \frac{1 - \mu_f}{2} D \left[ \frac{\partial}{\partial x} \left( \frac{\partial w}{\partial y} - \frac{Q_y}{G_c h_c} \right) + \frac{\partial}{\partial y} \left( \frac{\partial w}{\partial x} - \frac{Q_x}{G_c h_c} \right) \right] \quad (A2c)$$

$$\frac{\partial^2 M_x}{\partial x^2} - 2 \frac{\partial^2 M_{xy}}{\partial x \partial y} + \frac{\partial^2 M_y}{\partial y^2} = 2 \sigma_{c,t_f} \frac{\partial^2 w}{\partial x^2} \quad (A2d)$$

$$Q_x = -\frac{\partial M_{xy}}{\partial y} + \frac{\partial M_x}{\partial x} \quad (A2e)$$

$$Q_y = -\frac{\partial M_{xy}}{\partial x} + \frac{\partial M_y}{\partial y} \quad (A2f)$$

where  $M_x$ ,  $M_y$ ,  $M_{xy}$  are the bending and twisting moments,  $Q_x$ ,  $Q_y$  are the shear forces, and  $w$  is the middle-surface deflection at the point  $(x, y)$  in the sandwich plate. Equations (A2) constitute the six fundamental differential equations for elastic buckling of solid-core sandwich plates.

An equation in terms of the middle-surface deflection  $w$  alone can be obtained. Substitution of the expressions for

$M_x$ ,  $M_y$ , and  $M_{xy}$  given in equations (A2a) to (A2c) into equation (A2d) yields

$$-D \nabla^4 w + \frac{D}{G_c h_c} \nabla^2 \left( \frac{\partial Q_x}{\partial x} + \frac{\partial Q_y}{\partial y} \right) - 2 \sigma_{c,t_f} \frac{\partial^2 w}{\partial x^2} = 0 \quad (A3)$$

But, from equations (A2d) to (A2f),

$$\frac{\partial Q_x}{\partial x} + \frac{\partial Q_y}{\partial y} = 2 \sigma_{c,t_f} \frac{\partial^2 w}{\partial x^2} \quad (A4)$$

Hence equation (A3) reduces to

$$\nabla^4 w + \left( 1 - \frac{D}{G_c h_c} \right) \frac{2 \sigma_{c,t_f}}{D} \frac{\partial^2 w}{\partial x^2} = 0 \quad (A5)$$

Equation (A5) is identical with equation (71) of reference 3 for a plate under compression in one direction.

Since the plate is simply supported on all edges, the deflection surface may be taken as

$$w = A \sin \frac{m\pi x}{a} \sin \frac{\pi y}{b} \quad (A6)$$

yielding the stability criterion

$$k = \frac{\left( \frac{m}{\beta} + \frac{\beta}{m} \right)^2}{1 + r \left( 1 + \frac{m^2}{\beta^2} \right)} \quad (A7)$$

The value of  $m$  to be used in equation (A7) is that which yields the lowest value of  $k$  for given values of  $r$  and  $\beta$ .

Equations for elastic buckling of infinitely long simply supported sandwich plates under compression are obtained by minimizing equation (A7) with respect to  $\beta/m$ . This procedure yields

$$\left. \begin{aligned} \frac{\beta}{m} &= \sqrt{\frac{1-r}{1+r}} \\ k &= \frac{4}{(1+r)^2} \end{aligned} \right\} \quad (r \leq 1) \quad (A8)$$

and

$$\left. \begin{aligned} \frac{\beta}{m} &= 0 \\ k &= \frac{1}{r} \end{aligned} \right\} \quad (r \geq 1) \quad (A9)$$

The buckling coefficient given by equation (A9) corresponds to failure of the core material under the action of the core shear forces.

Equations (A7) to (A9) are similar to equations (76), (79), and (79a) of reference 3.

## APPENDIX B

### DERIVATION OF COMPRESSIVE BUCKLING EQUATION FOR SIMPLY SUPPORTED SOLID-CORE SANDWICH PLATES STRESSED IN THE PLASTIC RANGE

When the faces of sandwich plates are stressed in the plastic range, the buckling theory used in appendix A is no longer applicable. The equations of equilibrium, equations (A2d) to (A2f), remain unchanged but the deformation equations, (A2a) to (A2c), must be modified to include plastic effects. This modification may be readily made by means of the plastic buckling theory of reference 4 which is based on the plastic stress-strain relations characteristic of the deformation theory of plasticity. The stress-strain relations involve the assumptions that the plate material is isotropic and incompressible and that no part of the plate unloads during buckling.

Since in the sandwich plates considered in this report the applied forces are assumed to be carried only by the faces and the stresses arising from these forces are assumed to be distributed uniformly across the thickness of the faces, the bending and twisting moments are given by the equations

$$\left. \begin{aligned} M_x &= (\delta\sigma_x^U - \delta\sigma_x^L) \frac{t_f(h_c + t_f)}{2} \\ M_y &= (\delta\sigma_y^U - \delta\sigma_y^L) \frac{t_f(h_c + t_f)}{2} \\ M_{xy} &= -(\delta\tau_{xy}^U - \delta\tau_{xy}^L) \frac{t_f(h_c + t_f)}{2} \end{aligned} \right\} \quad (B1)$$

where  $\delta\sigma_x$ ,  $\delta\sigma_y$ ,  $\delta\tau_{xy}$  are small variations of the average stresses in the faces when buckling occurs from their values before buckling. The superscripts *U* and *L* refer to the upper and lower faces, respectively. The positive direction of  $M_{xy}$  is taken in accordance with that given in reference 1 and is the negative of that given in reference 2.

Expressions for the variations of the average stresses in the faces may be obtained from the general treatment of reference 2. For the case of a plate compressed in the *x*-direction, these equations are

$$\left. \begin{aligned} \delta\sigma_x &= \frac{4}{3} E_s \left\{ \left[ \epsilon_1 + \frac{1}{2} \epsilon_2 - \frac{3}{4} \left( 1 - \frac{E_T}{E_s} \right) \chi_1 z_0 \right] \mp \left( \frac{h_c + t_f}{2} \right) \left( C_1 \chi_1 + \frac{1}{2} \chi_2 \right) \right\} \\ \delta\sigma_y &= \frac{4}{3} E_s \left[ \left( \epsilon_2 + \frac{1}{2} \epsilon_1 \right) \mp \left( \frac{h_c + t_f}{2} \right) \left( \chi_2 + \frac{1}{2} \chi_1 \right) \right] \\ \delta\tau_{xy} &= \frac{2}{3} E_s \left[ \epsilon_3 \mp \left( \frac{h_c + t_f}{2} \right) \chi_3 \right] \end{aligned} \right\} \quad (B2)$$

where

$\epsilon_1, \epsilon_2, \epsilon_3$  variations of middle-surface strains  
 $\chi_1, \chi_2, \chi_3$  parts of plate bending and twisting curvatures that cause stresses in the faces  
 $z_0$  coordinate of neutral surface of plate  
 The upper and lower signs refer to the upper and lower faces of the plate, respectively.

The deformations due to vertical shear consist merely of a sliding of the plate cross sections with respect to one another and hence do not contribute to the face stresses. The curvatures due to shear deflections therefore must be subtracted from the total plate curvatures to give the curvatures used in equations (B2). Then, if the core is assumed to be stressed in the elastic range,

$$\left. \begin{aligned} \chi_1 &= \frac{\partial}{\partial x} \left( \frac{\partial w}{\partial x} - \frac{Q_x}{G_c h_c} \right) \\ \chi_2 &= \frac{\partial}{\partial y} \left( \frac{\partial w}{\partial y} - \frac{Q_y}{G_c h_c} \right) \\ \chi_3 &= \frac{1}{2} \left[ \frac{\partial}{\partial y} \left( \frac{\partial w}{\partial x} - \frac{Q_x}{G_c h_c} \right) + \frac{\partial}{\partial x} \left( \frac{\partial w}{\partial y} - \frac{Q_y}{G_c h_c} \right) \right] \end{aligned} \right\} \quad (B3)$$

The substitution of equations (B2) and (B3) into equations (B1) yields the modified deformation equations

$$\left. \begin{aligned} M_x &= -\frac{4}{3} \psi B \left[ C_1 \frac{\partial}{\partial x} \left( \frac{\partial w}{\partial x} - \frac{Q_x}{G_c h_c} \right) + \frac{1}{2} \frac{\partial}{\partial y} \left( \frac{\partial w}{\partial y} - \frac{Q_y}{G_c h_c} \right) \right] \\ M_y &= -\frac{4}{3} \psi B \left[ \frac{\partial}{\partial y} \left( \frac{\partial w}{\partial y} - \frac{Q_y}{G_c h_c} \right) + \frac{1}{2} \frac{\partial}{\partial x} \left( \frac{\partial w}{\partial x} - \frac{Q_x}{G_c h_c} \right) \right] \\ M_{xy} &= \frac{1}{3} \psi B \left[ \frac{\partial}{\partial y} \left( \frac{\partial w}{\partial x} - \frac{Q_x}{G_c h_c} \right) + \frac{\partial}{\partial x} \left( \frac{\partial w}{\partial y} - \frac{Q_y}{G_c h_c} \right) \right] \end{aligned} \right\} \quad (B4)$$

Equations (B4) together with equations (A2d) to (A2f) of appendix A constitute the six fundamental differential equations for plastic compressive buckling of solid-core sandwich plates. Equations (A2d) to (A2f) are

$$\left. \begin{aligned} \frac{\partial^2 M_x}{\partial x^2} - 2 \frac{\partial^2 M_{xy}}{\partial x \partial y} + \frac{\partial^2 M_y}{\partial y^2} &= 2\sigma_{cr} t_f \frac{\partial^2 w}{\partial x^2} \\ Q_x &= -\frac{\partial M_{xy}}{\partial y} + \frac{\partial M_x}{\partial x} \\ Q_y &= -\frac{\partial M_{xy}}{\partial x} + \frac{\partial M_y}{\partial y} \end{aligned} \right\} \quad (B5)$$

Unlike the elastic buckling theory, the theory for plastic buckling does not yield a single equation in the middle-surface deflection  $w$ . The number of equations necessary for the determination of the compressive buckling load may be reduced to three if equations (B4) are substituted into equations (B5), so that

$$\left. \begin{aligned} \frac{\partial Q_x}{\partial x} + \frac{\partial Q_y}{\partial y} - 2\sigma_{ctf} \frac{\partial^2 w}{\partial x^2} &= 0 \\ \left( \frac{1}{4} \frac{\partial^2}{\partial y^2} + C_1 \frac{\partial^2}{\partial x^2} - \frac{3}{4} \frac{G_c h_c}{\psi B} \right) \frac{Q_x}{G_c h_c} + \frac{3}{4} \frac{\partial^2}{\partial x \partial y} \frac{Q_y}{G_c h_c} - \\ \frac{\partial}{\partial x} \left( \frac{\partial^2}{\partial y^2} + C_1 \frac{\partial^2}{\partial x^2} \right) w &= 0 \\ \frac{3}{4} \frac{\partial^2}{\partial x \partial y} \frac{Q_x}{G_c h_c} + \left( \frac{1}{4} \frac{\partial^2}{\partial x^2} + \frac{\partial^2}{\partial y^2} - \frac{3}{4} \frac{G_c h_c}{\psi B} \right) \frac{Q_y}{G_c h_c} - \\ \frac{\partial}{\partial y} \left( \frac{\partial^2}{\partial x^2} + \frac{\partial^2}{\partial y^2} \right) w &= 0 \end{aligned} \right\} \quad (\text{B6})$$

The conditions that must be satisfied at the edges of a simply supported sandwich plate are

$$\left. \begin{aligned} v = M_x = \frac{Q_y}{G_c h_c} &= 0 & (\text{at } x=0, a) \\ w = M_y = \frac{Q_x}{G_c h_c} &= 0 & (\text{at } y=0, b) \end{aligned} \right\} \quad (\text{B7})$$

Solutions of equations (B6) that satisfy these boundary conditions are

$$\left. \begin{aligned} w &= A_1 \sin \frac{m\pi x}{a} \sin \frac{\pi y}{b} \\ \frac{Q_x}{G_c h_c} &= A_2 \cos \frac{m\pi x}{a} \sin \frac{\pi y}{b} \\ \frac{Q_y}{G_c h_c} &= A_3 \sin \frac{m\pi x}{a} \cos \frac{\pi y}{b} \end{aligned} \right\} \quad (\text{B8})$$

Substitution of equations (B8) in equations (B6) yields the set of equations

$$\left. \begin{aligned} \frac{m\pi}{a} \left[ \left( \frac{\pi}{b} \right)^2 + C_1 \left( \frac{m\pi}{a} \right)^2 \right] A_1 - \left[ \frac{1}{4} \left( \frac{\pi}{b} \right)^2 + C_1 \left( \frac{m\pi}{a} \right)^2 + \frac{3}{4} \frac{G_c h_c}{\psi B} \right] A_2 - \frac{3}{4} \frac{m\pi}{a} \frac{\pi}{b} A_3 &= 0 \\ \frac{\pi}{b} \left[ \left( \frac{\pi}{b} \right)^2 + \left( \frac{m\pi}{a} \right)^2 \right] A_1 - \frac{3}{4} \frac{m\pi}{a} \frac{\pi}{b} A_2 - \left[ \frac{1}{4} \left( \frac{m\pi}{a} \right)^2 + \left( \frac{\pi}{b} \right)^2 + \frac{3}{4} \frac{G_c h_c}{\psi B} \right] A_3 &= 0 \\ \frac{2\sigma_{ctf}}{B} \frac{B}{G_c h_c} \left( \frac{m\pi}{a} \right)^2 A_1 + \frac{m\pi}{a} A_2 + \frac{\pi}{b} A_3 &= 0 \end{aligned} \right\} \quad (\text{B9})$$

Since  $A_1$ ,  $A_2$ , and  $A_3$  must have values other than zero, setting the determinant of the coefficients of  $A_1$ ,  $A_2$ , and  $A_3$  equal to zero yields the stability criterion

$$k'_{pi} = \psi \frac{\left( \frac{\beta}{m} \right)^6 \left( 1 + \frac{1}{3} \psi s \right) + \left( \frac{\beta}{m} \right)^4 \left[ 2 + \frac{1}{3} \psi s (4C_1 - 1) \right] + \left( \frac{\beta}{m} \right)^2 \left[ C_1 + \frac{1}{3} \psi s (5C_1 - 2) \right] + \frac{1}{3} C_1 \psi s}{\left( \frac{\beta}{m} \right)^4 \left( 1 + \frac{5}{3} \psi s + \frac{4}{9} \psi^2 s^2 \right) + \left( \frac{\beta}{m} \right)^2 \left[ \frac{1}{3} \psi s (4C_1 + 1) + \frac{8}{9} \psi^2 s^2 (2C_1 - 1) \right] + \frac{4}{9} C_1 \psi^2 s^2} \quad (\text{B10})$$

The plastic compressive buckling load of infinitely long sandwich plates may be obtained by minimizing equation (B10) with respect to  $\beta/m$ . This procedure yields

$$\left( \frac{\beta}{m} \right)^8 \left[ \left( 1 + \frac{1}{3} \psi s \right) \left( 1 + \frac{4}{3} \psi s \right) \right] + \left( \frac{\beta}{m} \right)^6 \left\{ \frac{2}{3} \psi s \left( 1 + \frac{1}{3} \psi s \right) \left[ 1 + 4C_1 + \frac{8}{3} \psi s (2C_1 - 1) \right] \right\} + \left( \frac{\beta}{m} \right)^4 \left[ \frac{8}{27} \psi^3 s^3 (8C_1^2 - 7C_1 + 2) + \frac{1}{9} \psi^2 s^2 (16C_1^2 + 15C_1 - 7) + \frac{2}{3} \psi s (2 - C_1) - C_1 \right] + \left( \frac{\beta}{m} \right)^2 \left\{ \frac{2}{3} C_1 \psi s \left[ \frac{8}{9} \psi^2 s^2 (2C_1 - 1) + \psi s - 1 \right] \right\} + \frac{1}{9} C_1 \psi^2 s^2 \left( \frac{4}{3} C_1 \psi s - 1 \right) = 0 \quad (\text{B11})$$

Equations (B10) and (B11) then determine the compressive buckling load of infinitely long sandwich plates. For any given values of the buckling stress and the shear stiffness parameter  $s$ , equation (B11) is used to find the value of  $\beta/m$  that yields the minimum value of  $k'_{pi}$ . This value of  $\beta/m$  is then substituted in equation (B10) to determine  $k'_{pi}$ . If all the values of  $\beta/m$  given by equation (B11) are imaginary; that is, if

$$s > \frac{3}{4} \frac{1}{C_1 \psi} \quad (\text{B12})$$

$\beta/m$  must be taken equal to zero in equation (B10), which becomes

$$k'_{\text{pl}} = \frac{1}{4s/3} \quad (\text{B13})$$

which is identical with equation (A9) if Poisson's ratio is taken equal to  $\frac{1}{2}$  in equation (A9).

If the buckling stress is in the elastic range,  $C_1$  and  $\psi$  are equal to unity and the equations for compressive buckling of finite solid-core sandwich plates reduce to

$$k' = \frac{\left(\frac{m}{\beta} + \frac{\beta}{m}\right)^2}{1 + \frac{4}{3}s\left(1 + \frac{m^2}{\beta^2}\right)} \quad (\text{B14})$$

and for compressive buckling of infinitely long sandwich plates,

$$\left. \begin{aligned} k' &= \frac{4}{\left(1 + \frac{4}{3}s\right)^2} \\ \frac{\beta}{m} &= \sqrt{\frac{1 - \frac{4}{3}s}{1 + \frac{4}{3}s}} \end{aligned} \right\} \left(s \leq \frac{3}{4}\right) \quad (\text{B15})$$

and

$$\left. \begin{aligned} k' &= \frac{1}{4s/3} \\ \frac{\beta}{m} &= 0 \end{aligned} \right\} \left(s \geq \frac{3}{4}\right) \quad (\text{B16})$$

Equations (B14) to (B16) are identical with equations (A7) to (A9) if Poisson's ratio in equations (A7) to (A9) is taken to be  $\frac{1}{2}$ .

#### REFERENCES

1. March, H. W.: Effects of Shear Deformation in the Core of a Flat Rectangular Sandwich Panel. Rep. No. 1583, Forest Products Lab., U. S. Dept. Agric., May 1948.
2. Libove, Charles, and Batdorf, S. B.: A General Small-Deflection Theory for Flat Sandwich Plates. NACA Rep. 899, 1948.
3. Reissner, Eric: Finite Deflections of Sandwich Plates. Jour. Aero. Sci., vol. 15, no. 7, July 1948, pp. 435-440.
4. Stowell, Elbridge Z.: A Unified Theory of Plastic Buckling of Columns and Plates. NACA Rep. 898, 1948.
5. Boller, K. H.: Buckling Loads of Flat Sandwich Panels in Compression. The Buckling of Flat Sandwich Panels with Edges Simply Supported. Rep. No. 1525-A, Forest Products Lab., U. S. Dept. Agric., Feb. 1947.

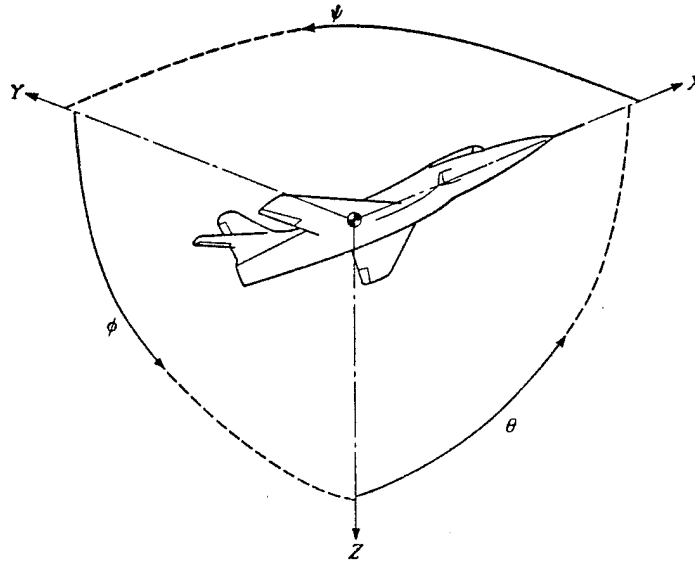

Positive directions of axes and angles (forces and moments) are shown by arrows

Axis		Force (parallel to axis) symbol	Moment about axis			Angle		Velocities	
Designation	Sym- bol		Designation	Sym- bol	Positive direction	Designa- tion	Sym- bol	Linear (compo- nent along axis)	Angular
Longitudinal.....	X	X	Rolling.....	L	Y → Z	Roll.....	φ	u	p
Lateral.....	Y	Y	Pitching.....	M	Z → X	Pitch.....	θ	v	q
Normal.....	Z	Z	Yawing.....	N	X → Y	Yaw.....	ψ	w	r

Absolute coefficients of moment

$$C_l = \frac{L}{qbS} \quad C_m = \frac{M}{qcS} \quad C_n = \frac{N}{qbS}$$

(rolling)      (pitching)      (yawing)

Angle of set of control surface (relative to neutral position),  $\delta$ . (Indicate surface by proper subscript.)

#### 4. PROPELLER SYMBOLS

$D$	Diameter	$P$	Power, absolute coefficient $C_P = \frac{P}{\rho n^3 D^5}$
$p$	Geometric pitch	$C_s$	Speed-power coefficient = $\sqrt{\frac{\rho V^3}{P n^2}}$
$p/D$	Pitch ratio	$\eta$	Efficiency
$V'$	Inflow velocity	$n$	Revolutions per second, rps
$V_s$	Slipstream velocity	$\phi$	Effective helix angle = $\tan^{-1} \left( \frac{V}{2\pi r n} \right)$
$T$	Thrust, absolute coefficient $C_T = \frac{T}{\rho n^2 D^4}$		
$Q$	Torque, absolute coefficient $C_Q = \frac{Q}{\rho n^2 D^5}$		

#### 5. NUMERICAL RELATIONS

1 hp = 76.04 kg-m/s = 550 ft-lb/sec  
 1 metric horsepower = 0.9863 hp  
 1 mph = 0.4470 mps  
 1 mps = 2.2369 mph

1 lb = 0.4536 kg  
 1 kg = 2.2046 lb  
 1 mi = 1,609.35 m = 5,280 ft  
 1 m = 3.2808 ft