

U-9977

NATIONAL ADVISORY COMMITTEE FOR AERONAUTICS

DTIC
SELECTED
SEP 06 1995
S **D**
F

REPORT No. 919

ACCURACY OF AIRSPEED MEASUREMENTS AND FLIGHT CALIBRATION PROCEDURES

By WILBER B. HUSTON

FILE COPY
NAVY RESEARCH SECTION
SCIENCE DIVISION
LIBRARY OF CONGRESS
TO BE RETURNED



NAVY RESEARCH SECTION
SCIENCE DIVISION
REFERENCE DEPARTMENT
LIBRARY OF CONGRESS

DISTRIBUTION STATEMENT A
Approved for public release
Distribution Unlimited

APR 4 1950

Copy #2

1948

For sale by the Superintendent of Documents, U. S. Government Printing Office, Washington 25, D. C. Yearly subscription, \$3; foreign, \$4.50; single copy price varies according to size. Price 25 cents

19950831 104

DTIC QUALITY INSPECTED 5

AERONAUTIC SYMBOLS

1. FUNDAMENTAL AND DERIVED UNITS

	Symbol	Metric		English	
		Unit	Abbrevia- tion	Unit	Abbreviation
Length.....	<i>l</i>	meter.....	m	foot (or mile).....	ft (or mi)
Time.....	<i>t</i>	second.....	s	second (or hour).....	sec (or hr)
Force.....	<i>F</i>	weight of 1 kilogram.....	kg	weight of 1 pound.....	lb
Power.....	<i>P</i>	horsepower (metric).....		horsepower.....	hp
Speed.....	<i>V</i>	kilometers per hour.....	kph	miles per hour.....	mph
		meters per second.....	mps	feet per second.....	fps

2. GENERAL SYMBOLS

<p><i>W</i> Weight = mg</p> <p><i>g</i> Standard acceleration of gravity = 9.80665 m/s^2 or 32.1740 ft/sec^2</p> <p><i>m</i> Mass = $\frac{W}{g}$</p> <p><i>I</i> Moment of inertia = mk^2. (Indicate axis of radius of gyration <i>k</i> by proper subscript.)</p> <p><i>μ</i> Coefficient of viscosity</p>	<p><i>ν</i> Kinematic viscosity</p> <p><i>ρ</i> Density (mass per unit volume) Standard density of dry air, $0.12497 \text{ kg-m}^{-3}\text{-s}^2$ at 15° C and 760 mm; or $0.002378 \text{ lb-ft}^{-3}\text{-sec}^2$</p> <p>Specific weight of "standard" air, 1.2255 kg/m^3 or 0.07651 lb/cu ft</p>
---	--

3. AERODYNAMIC SYMBOLS

<p><i>S</i> Area</p> <p><i>S_w</i> Area of wing</p> <p><i>G</i> Gap</p> <p><i>b</i> Span</p> <p><i>c</i> Chord</p> <p><i>A</i> Aspect ratio, $\frac{b^2}{S}$</p> <p><i>V</i> True air speed</p> <p><i>q</i> Dynamic pressure, $\frac{1}{2}\rho V^2$</p> <p><i>L</i> Lift, absolute coefficient $C_L = \frac{L}{qS}$</p> <p><i>D</i> Drag, absolute coefficient $C_D = \frac{D}{qS}$</p> <p><i>D₀</i> Profile drag, absolute coefficient $C_{D_0} = \frac{D_0}{qS}$</p> <p><i>D_i</i> Induced drag, absolute coefficient $C_{D_i} = \frac{D_i}{qS}$</p> <p><i>D_p</i> Parasite drag, absolute coefficient $C_{D_p} = \frac{D_p}{qS}$</p> <p><i>C</i> Cross-wind force, absolute coefficient $C_c = \frac{C}{qS}$</p>	<p><i>i_w</i> Angle of setting of wings (relative to thrust line)</p> <p><i>i_t</i> Angle of stabilizer setting (relative to thrust line)</p> <p><i>Q</i> Resultant moment</p> <p><i>Ω</i> Resultant angular velocity</p> <p><i>R</i> Reynolds number, $\rho \frac{Vl}{\mu}$ where <i>l</i> is a linear dimension (e.g., for an airfoil of 1.0 ft chord, 100 mph, standard pressure at 15° C, the corresponding Reynolds number is 935,400; or for an airfoil of 1.0 m chord, 100 mps, the corresponding Reynolds number is 6,865,000)</p> <p><i>α</i> Angle of attack</p> <p><i>ε</i> Angle of downwash</p> <p><i>α₀</i> Angle of attack, infinite aspect ratio</p> <p><i>α_i</i> Angle of attack, induced</p> <p><i>α_t</i> Angle of attack, absolute (measured from zero-lift position)</p> <p><i>γ</i> Flight-path angle</p>
--	--

REPORT No. 919

ACCURACY OF AIRSPEED MEASUREMENTS AND FLIGHT CALIBRATION PROCEDURES

By WILBER B. HUSTON

Langley Memorial Aeronautical Laboratory
Langley Field, Va.

Accession For	
NTIS CRA&I	<input checked="" type="checkbox"/>
DTIC TAB	<input type="checkbox"/>
Unannounced	<input type="checkbox"/>
Justification	
By	
Distribution /	
Availability Codes	
Dist	Avail and/or Special
A-1	

National Advisory Committee for Aeronautics

Headquarters, 1725 F Street NW, Washington 25, D. C.

Created by act of Congress approved March 3, 1915, for the supervision and direction of the scientific study of the problems of flight (U. S. Code, title 50, sec. 151). Its membership was increased to 17 by act approved May 25, 1948. Public Law 549, 80th Congress. The members are appointed by the President, and serve as such without compensation.

JEROME C. HUNSAKER, Sc. D., Cambridge, Mass., *Chairman*

ALEXANDER WETMORE, Sc. D., Secretary, Smithsonian Institution, *Vice Chairman*

HON. JOHN R. ALISON, Assistant Secretary of Commerce.	EDWARD M. POWERS, Major General, United States Air Force, Assistant Chief of Air Staff-4.
DELEA W. BRONK, Ph. D., President, Johns Hopkins University.	JOHN D. PRICE, Vice Admiral, United States Navy, Deputy Chief of Naval Operations - Air.
KARL T. COMPTON, Ph. D., Chairman, Research and Development Board, National Military Establishment.	ARTHUR E. RAYMOND, M. S., Vice President, Engineering, Douglas Aircraft Co., Inc.
EDWARD U. CONDON, Ph. D., Director, National Bureau of Standards.	FRANCIS W. REICHELDERFER, Sc. D., Chief, United States Weather Bureau.
JAMES H. DOOLITTLE, Sc. D., Vice President, Shell Union Oil Corp.	HON. DELOS W. RENTZEL, Administrator of Civil Aeronautics, Department of Commerce.
R. M. HAZEN, B. S., Director of Engineering, Allison Division, General Motors Corp.	HOYT S. VANDENBERG, General, Chief of Staff, United States Air Force.
WILLIAM LITTLEWOOD, M. E., Vice President, Engineering, American Airlines, Inc.	THEODORE P. WRIGHT, Sc. D., Vice President for Research, Cornell University.
THEODORE C. LONNQUEST, Rear Admiral, United States Navy, Assistant Chief for Research and Development, Bureau of Aeronautics.	

HUGH L. DRYDEN, Ph. D., *Director of Aeronautical Research*

JOHN F. VICTORY, LL.M., *Executive Secretary*

JOHN W. CROWLEY, JR., B. S., *Associate Director of Aeronautical Research*

E. H. CHAMBERLAIN, *Executive Officer*

HENRY J. E. REID, Eng. D., Director, Langley Aeronautical Laboratory, Langley Field, Va.

SMITH J. DEFRANCE, B. S., Director, Ames Aeronautical Laboratory, Moffett Field, Calif.

EDWARD R. SHARP, Sc. D., Director, Lewis Flight Propulsion Laboratory, Cleveland Airport, Cleveland, Ohio

TECHNICAL COMMITTEES

AERODYNAMICS
POWER PLANTS FOR AIRCRAFT
AIRCRAFT CONSTRUCTION

OPERATING PROBLEMS
INDUSTRY CONSULTING

Coordination of Research Needs of Military and Civil Aviation

Preparation of Research Programs

Allocation of Problems

Prevention of Duplication

Consideration of Inventions

LANGLEY AERONAUTICAL LABORATORY,
Langley Field, Va.

LEWIS FLIGHT PROPULSION LABORATORY,
Cleveland Airport, Cleveland, Ohio

AMES AERONAUTICAL LABORATORY,
Moffett Field, Calif.

Conduct, under unified control, for all agencies, of scientific research on the fundamental problems of flight

OFFICE OF AERONAUTICAL INTELLIGENCE,
Washington, D. C.

Collection, classification, compilation, and dissemination of scientific and technical information on aeronautics

CONTENTS

	Page		Page
SUMMARY.....	1	LAG IN PRESSURE-MEASURING SYSTEMS—Continued	
INTRODUCTION.....	1	Determination of Lag Constant by Experimental Methods—Continued	
SYMBOLS.....	1	Procedure for use with photographic records.....	19
PRECISION OF AIRSPEED MEASUREMENTS.....	2	Corrections of Flight Data for Lag.....	19
Precision of Mach Number.....	3	Pressure-altitude and static-pressure measurements.....	19
Precision of Temperature.....	4	Impact-pressure measurements.....	20
Precision of True Airspeed.....	4	Methods for Reducing Lag.....	23
Effect of Humidity.....	4	Criterion for Avoiding Lag Corrections.....	23
CHARACTERISTICS OF TOTAL- AND STATIC-PRESSURE HEADS.....	5	PRESSURE INSTRUMENTS.....	23
Total-Pressure Heads.....	5	The Airspeed Indicator.....	25
Effect of angle of attack, Mach number, and orifice diameter.....	5	The Altimeter.....	25
Effect of turbulence.....	6	NACA Instruments.....	26
Effect of drain holes.....	6	TEMPERATURE MEASUREMENTS.....	26
Static-Pressure Heads.....	6	Sources of Error.....	26
Effect of dimensions and design.....	6	Velocity effects.....	26
Effect of Mach number and angle of attack.....	7	Lag errors.....	27
Effect of small changes in configuration.....	7	Other errors.....	27
Effect of Reynolds number.....	7	Location of Temperature Probe.....	28
Service Pitot-Static Tubes.....	7	Evaluation of Free-Air Temperature.....	28
THE FIELD OF FLOW ABOUT AN AIRFOIL.....	9	FLIGHT CALIBRATION OF AIRSPEED AND TEMPERATURE INSTALLATIONS.....	28
Location of Static Head.....	9	Airspeed Installation.....	28
Location of Total-Pressure Head.....	12	Total-pressure error.....	31
Location of Static Vents.....	13	Static-pressure error.....	31
LAG IN PRESSURE-MEASURING SYSTEMS.....	13	Temperature Installation.....	34
Mathematical Theory.....	13	REFERENCES AND BIBLIOGRAPHY.....	34
Values of lag constant at sea level.....	15	General.....	34
Variation of lag constant with altitude.....	17	Pitot-Static Tubes.....	34
Determination of Lag Constant by Experimental Methods.....	17	Field of Flow Around an Airplane.....	35
Laminar-flow condition.....	17	Pressure Lag.....	35
Theoretical basis for measurement.....	17	Aircraft Instruments.....	35
Procedure for use with indicating instruments.....	19	Temperature Measurement.....	35
		Method of Measuring Airspeed.....	36

REPORT No. 919

ACCURACY OF AIRSPEED MEASUREMENTS AND FLIGHT CALIBRATION PROCEDURES

By WILBER B. HUSTON

SUMMARY

The sources of error that may enter into the measurement of airspeed by pitot-static methods are reviewed in detail together with methods of flight calibration of airspeed installations. Special attention is given to the problem of accurate measurements of airspeed under conditions of high speed and maneuverability required of military airplanes.

The accuracy of airspeed measurement is discussed as limited by errors in each of the quantities that is directly measured in flight. Existing data on the errors at the total- and static-pressure openings associated with the geometry of pitot-static tubes are summarized, followed by charts and a qualitative description of the errors caused by operation within the pressure field of the airfoil. The errors introduced at the measuring end of the system due to lag in pressure transmission are reviewed and some new material on this subject is included along with methods and charts for making appropriate lag corrections to airspeed measurements.

A brief discussion is given of the magnitude and type of error introduced by the mechanical and elastic characteristics of the conventional airspeed indicator and altimeter. Similar material is given for typical NACA pressure-recording instruments. Since knowledge of true airspeed is dependent upon a temperature measurement, existing material on the accuracy with which temperature can be measured with various types of probes is summarized and discussed. Methods used by the National Advisory Committee for Aeronautics in flight calibrations of airspeed and temperature installations are outlined.

The present report has been arranged in such a way that each section may be read independently of the others. An attempt has been made to consider all factors that limit the accuracy with which airspeed may be determined by the usual pitot-static methods.

INTRODUCTION

Accurate determination of Mach number and true airspeed is of fundamental importance in the flight testing of aircraft. Although the increasing demand for greater speed, altitude, and maneuverability has brought about refinements in measuring technique, the differential pressure indicator or recorder connected to sources of total and static pressure remains the standard means of measuring airspeed up to a Mach number of about 0.95.

The determination of Mach number and true airspeed by means of pitot-static arrangements is limited in accuracy by errors which may be separated into the following five broad categories:

- (1) Errors associated with the geometry of the pitot-static tube
- (2) Errors induced by the field of flow about the airfoil
- (3) Errors caused by lag in the tubing which connects the pitot-static tube with the indicating or recording mechanism
- (4) Errors due to the indicating or recording mechanism
- (5) Errors in the determination of free-air temperature

The purposes of the present report are to bring together from many different papers the results of investigations of these errors and to present this information in a form suitable for convenient use. The published results of these investigations have been combined with unpublished results obtained at the Langley Memorial Aeronautical Laboratory of the NACA in such a manner as to be useful to those who plan airspeed instrumentation and interpret data obtained in flight. Each section is independent of the others and may, therefore, be read separately.

Special attention has been given to the magnitude or importance of the various errors and to methods of correcting them. Cognizance has been taken of those conditions under which rates of change of speed or altitude are high such as maneuvers required of some military airplanes.

The supplementary tables required in determining Mach number, the speed of sound, and the properties of the U.S. standard atmosphere are given in reference 10.

An extensive bibliography covering all material reviewed and judged to be of interest, with the exception of several valuable British papers of limited distribution, has been prepared.

SYMBOLS

<i>A</i>	area, feet ²
<i>a</i>	speed of sound in dry air, feet per second
<i>a_w</i>	speed of sound in moist air, feet per second
<i>B</i>	volume coefficient of elasticity, equation (20), feet ³ per pound
<i>C</i>	capacitance of a container defined by equation (18), feet ³ /(lb/ft ²)

C_L	airplane lift coefficient
c	airfoil chord, feet
c_l	airfoil section lift coefficient
c_p, c_v	specific heats at constant pressure and volume, respectively, Btu per pound °F
D	diameter, feet
e/p	ratio of partial pressure of water vapor in atmosphere to static pressure
g	acceleration due to gravity (32.1740 ft/sec ² for U.S. standard atmosphere)
H	total pressure, pounds per foot ²
h	absolute altitude, feet; surface heat-transfer coefficient, Btu/(sec) (ft ²) (°F)
h_p	pressure altitude, feet
i	impact orifice diameter, feet
K	temperature recovery factor defined by equation (46); pitot-static-tube calibration factor
k	thermal conductivity, Btu/(sec) (ft ²) (°F/ft)
L	length, feet; constant, equation (47)
m	equivalent mass, (slugs/ft ³)/foot
M	Mach number (V/a)
n	load factor; constant, equation (47)
Pr	Prandtl number ($c_p \mu g/k$)
p	static pressure, pounds per foot ² or inches of water
p_0	sea-level pressure in standard atmosphere (2116.229 lb/ft ² or 407.2 in. water)
q	dynamic pressure, pounds per foot ² $\left(\frac{1}{2} \rho V^2; \frac{\gamma}{2} p M^2\right)$
q_c	impact pressure, difference between total pressure and static pressure, pounds per foot ²
q_c/p	compression ratio
R	constant in perfect gas law $\frac{p}{\rho} = RgT$; resistance to fluid flow defined by equation (17), pound-seconds per foot ⁵
Re	Reynolds number ($VD\rho/\mu$)
T	temperature of free stream, °F absolute
T_0	temperature at sea level in standard atmosphere, 518.4°F absolute or 59°F
T_t	theoretical temperature of a flat plate, °F absolute
T_r	total temperature defined by equation (43), °F absolute
t	time, seconds
v	volume, feet ³
v_0	volume of elastic container with no load, feet ³
V	true airspeed, feet per second
V_i	indicated airspeed, feet per second
W/S	wing loading, pounds per foot ²
x_N, x_C, x_S	distance between static orifices and nose, collar, and stem, respectively, in diameters of pitot-static tube
α	angle of attack
γ	ratio of specific heats, taken as 1.4 for air in standard tables (c_p/c_v)

Δ	error in a quantity (indicated value minus true value)
Δp_λ	error in pressure due to lag
θ	dive angle, measured from horizontal, degrees
λ	lag constant, seconds
λ_H	lag constant of total-pressure system, seconds
λ_p	lag constant of static-pressure system, seconds
μ	coefficient of viscosity, slugs per foot-second
ν	kinematic viscosity, feet ² per second (μ/ρ)
ρ	density, slugs per foot ³
ρ_0	sea-level density of dry air in standard atmosphere (0.002378 slug/ft ³)
τ	acoustic lag due to finite speed of sound, seconds
ζ	local angle of flow relative to airfoil chord, degrees
Superscripts and subscripts:	
'	measured or indicated quantity
0	sea-level conditions in the U.S. standard atmosphere
a	aneroid capsule
c	instrument case
cr	critical
d	difference
e	equivalent
obs	observed
r	reference airplane
t	connecting tubing

PRECISION OF AIRSPEED MEASUREMENTS

In this section the general equations are given relating Mach number and airspeed to the directly measurable quantities, static pressure, impact pressure, and indicated free-air temperature. An investigation is made of the error in M , T , and V (see list of symbols for definitions) resulting from an error in the pertinent measurements. The effects of humidity are evaluated and shown to be small.

Total or pitot pressure as developed at the pitot orifice of a pitot-static tube is the sum of two components: free-stream static pressure and impact pressure. The relationship between the total pressure, the true free-stream static pressure, and the speed of flow is given in the following equation which is based on the Bernoulli relation for adiabatic compressible flow:

$$H = q_c + p$$

$$= p \left(1 + \frac{\gamma-1}{2} M^2 \right)^{\frac{\gamma}{\gamma-1}} = p \left(1 + \frac{\gamma-1}{2} \frac{V^2}{a^2} \right)^{\frac{\gamma}{\gamma-1}} \quad (1)$$

where $M < 1$ and the speed is expressed in terms of Mach number

$$M = \frac{V}{a} \quad (2)$$

and

$$a = \sqrt{\gamma p / \rho}$$

$$= \sqrt{\gamma R g T} \quad (3)$$

These relationships show that Mach number can be derived from two measurable quantities: the static pressure p and the differential or impact pressure q_c . The pressures may be measured either by instruments calibrated in units such as inches of water which are convenient for measuring pressure directly or by flight instruments calibrated in miles per hour and feet of pressure together with suitable computers, charts, or tables. (See references 5, 7, and 10.)

If the value 1.4 is used for γ , equations (1) and (3) are especially convenient for the routine analysis of flight data. Equation (1) can be reduced to

$$M = \sqrt{5 \left[\left(\frac{q_c}{p} + 1 \right)^{2/7} - 1 \right]} \quad (4)$$

A tabular expression of equations (3) and (4) is given in reference 10. By use of such tables the compression ratio q_c/p yields M directly. The true airspeed V can be derived from measured values of the air temperature and Mach number; the dynamic pressure q can be obtained from the relation

$$q = \frac{\gamma}{2} \rho M^2 \quad (5)$$

Pressure or pressure difference is seldom determined in flight research with an over-all precision greater than that corresponding to ± 0.5 inch of water. In the measurement of static pressure p a precision of ± 0.5 inch of water represents an error of only 0.5/400 or 0.125 percent at low altitudes; whereas the error is 2 percent at 65,000 feet. For values of q_c obtained at low speeds, such as those encountered in stall testing, a precision of ± 0.5 inch of water represents a large error, which may often be improved, however, by special instrumentation. For large values of q_c obtained at altitude, the error is smaller although dependent on altitude.

In pitot-static installations the total pressure H is usually developed to a high degree of accuracy. An error in the differential pressure Δq_c usually exists because of Δp , an error in the static-pressure system; thus, the precision with which static pressure is developed is a limiting factor in the accuracy with which differential pressure is known and is a critical factor in Mach number determination.

PRECISION OF MACH NUMBER

Mach number errors are customarily expressed in any of the following forms: ΔM (which equals $M' - M$), $\frac{\Delta M}{M}$, or $100 \frac{\Delta M}{M}$. The effect of errors in q_c , p , and H on the magnitudes of both ΔM and $\Delta M/M$ through large ranges of Mach number and altitude is illustrated in figure 1, based on the result of differentiating equation (4):

$$\frac{dM}{M} = \frac{M^2 + 5}{7M^2} \left(\frac{q_c}{p} + 1 \right)^{-1} \left(\frac{dq_c}{p} - \frac{q_c}{p} \frac{dp}{p} \right) \quad (6)$$

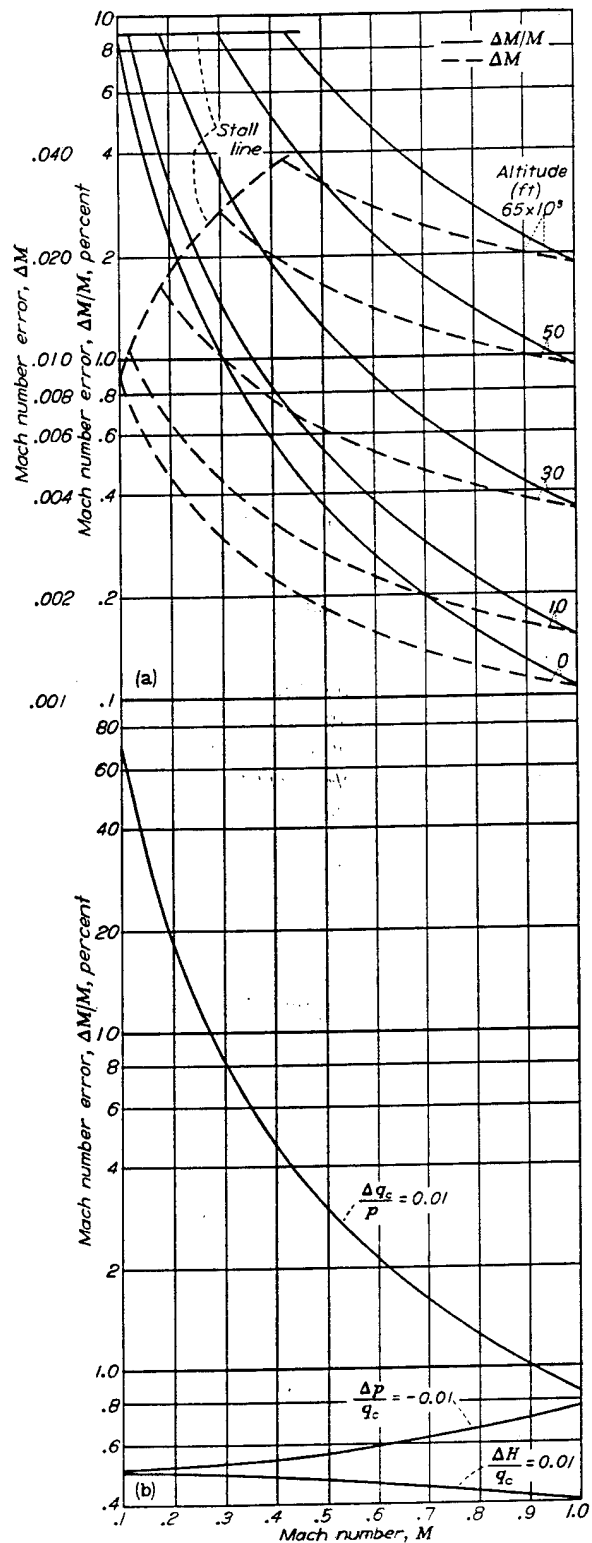

(a) Error in q_c and p of 0.5 inch of water.
 (b) Error in H , q_c , and p of 1 percent.
 FIGURE 1.—Mach number error corresponding to various errors in pressure measurement.

In figure 1 (a) the effect is shown of an error Δq_c of 0.5 inch of water which exists because of an equivalent error, $\Delta p = -0.5$ inch of water, in the static-pressure system. The curves of this figure are based on the following equation, which can be obtained from equation (6) when the measurement of H is considered exact and thus $dq_c = -dp$:

$$\begin{aligned} \frac{\Delta M}{M} &= \frac{M^2 + 5}{7M^2 p} \Delta q_c \\ &= -\frac{M^2 + 5}{7M^2} \frac{\Delta p}{p} \end{aligned} \quad (6a)$$

The curves have not been extended beyond a "stall line" which is arbitrarily based on the assumption that the Mach number for stall at any altitude is given by $M_{stall} = 0.1 \sqrt{p_0/p}$. Figure 1 (a) shows that except at very high altitudes or at low Mach numbers a precision either of ± 1 percent or of ± 0.01 in the Mach number is achieved if an error of only ± 0.5 inch of water exists in q_c and p . Errors inherent in the measurement process itself, however, may introduce inaccuracies which materially increase the value of ± 0.5 inch of water.

The precision of M corresponding to a 1-percent value of pressure defect is given in figure 1 (b). A pressure defect as used in this paper is the pressure error expressed in non-dimensional form, as $\Delta p/p$, $\Delta p/q_c$, and so forth. The curves for $\Delta H/q_c$ (p , exact) and $\Delta p/q_c$ (H , exact) are useful in the interpretation of calibration curves of pitot-static tubes. The curve for $\Delta q_c/p$ (H , exact) represents an error in q_c which exists because of 1-percent error in p . In order to determine the effect on M of errors in static pressure alone ($\frac{\Delta p}{p} = 0.01$; q_c , exact), the curve for $\Delta H/q_c$ may be used since a 1-percent error in either the numerator or the denominator of the compression ratio q_c/p results in the same magnitude of error in M .

Figures 1 (a) and 1 (b) can be used to determine the error in M for other conditions since ΔM and $\Delta M/M$ are directly proportional to the error in H , p , or q_c . They may also be used to estimate the precision necessary in pressure measurement to achieve a desired minimum error in M .

PRECISION OF TEMPERATURE

The temperature of the free air T is not indicated by a thermometer moving at speed M relative to the free stream but must be computed from the relation

$$T = \frac{T'}{1 + \frac{\gamma - 1}{2} KM^2}$$

where the temperature recovery factor K may have a value varying between 0.3 and 1.0 for different installations. The value of T used in equation (3) may, therefore, be in error because of limitations in the precision with which the values

of T' , K , and M may be determined. Based on a value of $\gamma = 1.4$, this error may be expressed by the root-mean-square of the contributing errors:

$$\frac{\Delta T}{T} = \pm \sqrt{\left(\frac{\Delta T'}{T'}\right)^2 + \left(\frac{0.2KM^2}{1 + 0.2KM^2}\right)^2 \left[\left(\frac{2\Delta M}{M}\right)^2 + \left(\frac{\Delta K}{K}\right)^2\right]} \quad (7)$$

In many installations, the value of K may not be known with a precision greater than ± 10 percent. At Mach numbers less than 0.3 although $\Delta M/M$ is as large as ± 10 percent, T may easily be determined with a precision greater than ± 1 percent. As M approaches 1, however, in order to achieve an accuracy in T of ± 1 percent when M is known to ± 1 percent, T' must be known with a precision greater than ± 1 percent and K , with a precision greater than ± 5 percent. For high-speed aircraft, especially those for navigational or research purposes, therefore, a thermometer installation with an accurately known value of recovery factor is essential.

PRECISION OF TRUE AIRSPEED

From equations (2) and (3), the root-mean-square error in true airspeed may be expressed as

$$\frac{\Delta V}{V} = \pm \sqrt{\left(\frac{\Delta M}{M}\right)^2 + \left(\frac{1}{2} \frac{\Delta T}{T}\right)^2} \quad (8)$$

In order to obtain the true airspeed to within an accuracy of 1 percent, the errors must be less than 1 percent for M and less than 2 percent for T , as indicated by equation (8).

At low speeds, at which $\frac{1}{2} \frac{\Delta T}{T}$ is usually much less than $\frac{\Delta M}{M}$, the precision of V is almost entirely dependent on the value of ΔM , and $\Delta V \approx 700 \Delta M$ (where V is given in mph).

The precision acceptable for V varies with the purpose of the measurements. Although airspeed indicators may be graduated in 1-mile-per-hour units and Mach numbers are often given to three significant figures, precision as high as such numbers indicate is contingent upon the ability to maintain or improve the accuracy of ± 0.5 inch of water in pressure measurements.

EFFECT OF HUMIDITY

Values of M and V computed by means of the tables or formulas for M and a are usually based on dry air and $\gamma = 1.4$. These values of M are accurate within 0.1 percent and for V within 0.4 percent at temperatures of 68° F or less. In warm summer weather under conditions of high humidity, requirements of high precision may indicate the need for a humidity correction. Since moist air is less dense than dry air at the same temperature and pressure, complete correction involves not only a change in the value of M as determined by equation (4) but also a correction for both γ and density in determining the speed of sound from equation (3).

The variation of γ with atmospheric conditions is given in the following table furnished by the National Bureau of Standards. (See reference 8.)

Temperature		γ for dry air		γ for saturated air	
°C	°F	760 mm Hg	0 mm Hg	760 mm Hg	0 mm Hg
40	104	1.4012	1.3998	1.3963	1.3935
20	68	1.4020	1.4003	1.3989	1.3965
0	32	1.4028	1.4007	1.4000	1.3983
-20	-4	1.4037	1.4010	1.4010	1.3994
-40	-40	1.4046	1.4012	1.4020	1.4004

Since $1.39 < \gamma < 1.41$, a simple linear correction can be applied to values of M derived from equation (4). The variation of M with γ for a range of q_c/p is shown in the following table, in which the change in M is only approximately ± 0.3 percent for a change of ± 0.01 in γ .

q_c/p	Mach number		
	$\gamma=1.39$	$\gamma=1.40$	$\gamma=1.41$
0.01	0.1198	0.1194	0.1189
.10	.3728	.3715	.3702
.20	.5183	.5171	.5153
.40	.7126	.7103	.7081
.60	.8502	.8477	.8452
.80	.9559	.9562	.9534

The speed of sound a_w in moist air of temperature T and partial vapor pressure e may be computed from the speed of sound a in dry air of the same temperature as given in standard tables in reference 10 (or by use of equation (3) with $\gamma=1.4$) by the following formula based on ordinary thermodynamic considerations:

$$a_w = \sqrt{\frac{1.4RgT}{(1-0.3783 \frac{e}{p})} \frac{\gamma}{1.4}} = a \sqrt{\frac{\gamma}{1.4(1-0.3783 \frac{e}{p})}} \quad (9)$$

The aforementioned data indicate that for dry air the standard tables give values of M that are slightly too large; whereas values of a are small in almost exactly the same proportion, the net error being less than 0.02 percent. For fully saturated air above freezing, values of both M and a are too small when computed from the standard tables. The resultant error in V is 0.4 percent at 68° F, although it increases to 1.4 percent at 104° F. Under most conditions in the temperature range of the standard atmosphere, therefore, no improvement in the precision of airspeed measurement in flight is gained by correcting for the effects of humidity.

CHARACTERISTICS OF TOTAL- AND STATIC-PRESSURE HEADS

In this section the discussion is limited to the isolated pitot-static device, unaffected by the interference effects of

fuselage or wing which may be present in a practical installation. The results of tests of a number of different pitot-static tubes are used to show the influence of the geometry of the head, angle of attack, Mach number, Reynolds number, turbulence, and drain holes on the development of total and static pressures. Calibration curves of standard pitot-static tubes are included.

TOTAL-PRESSURE HEADS

In accordance with the Bernoulli relation, the total-pressure H in the impact orifice of a pitot-static or total, pressure tube at a given airspeed is not affected by small changes in the local velocity due to the presence of the tube itself or of the airplane provided that the direction of flow is parallel to the axis of the head. Potential flow, free from circulation losses, is thus implied together with the further assumption that as the air comes to rest compression takes place adiabatically without sensible heat transfer.

The results of reference 22 indicate that when the axis of the head is parallel to the flow direction the value of H is given correctly by equation (1) for values of M as large as 0.995. Results contained in reference 1 indicate that for values of impact orifice diameter i ranging from 5 inches to 0.0097 inch and for small tubes at low velocity (Reynolds number greater than 30) H is independent of orifice diameter within 0.0002 inch of water.

Effect of angle of attack, Mach number, and orifice diameter.—The total-pressure defect $(H'-H)/q_c$ increases in magnitude as the angle of attack α increases from zero, decreases as M increases, and decreases as the ratio of impact orifice diameter to tube diameter i/D approaches 1.0. The magnitude of these effects for a tube with a hemispherically shaped nose is illustrated in figure 2. Figure 2 (a) was obtained by cross-plotting and extrapolating to $\frac{i}{D}=0.125$ the data in reference 20 which were obtained at a value of q of 3 inches of water in an open-jet tunnel (that is, $M \approx 0.1$). At $\alpha=24^\circ$ the defect is still zero for $\frac{i}{D}=1.0$.

The total-pressure defect for values of α from 0° to 20° in the region $0.57 < M < 0.995$ is illustrated in figure 2 (b), which is derived from reference 22. This tube, a Prandtl-type laboratory instrument, has a ratio i/D of 0.3, for which, in tubes of this type, the variation of total- and static-pressure errors with angle of attack is such as to give a nearly correct value of q_c . For given values of i and D if the nose shape is elongated (for example, semielliptical or ogival) the elongation is equivalent to an effective increase in the value of i/D , and the magnitude of the total-pressure defect at a given angle of attack will be less than is indicated by figure 2.

Investigation of the total-pressure defect for $0.3 < M < 0.9$ and angles of attack up to 180° (reference 24) shows that the defect $(H'-H)/q_c$ increased in magnitude to (approx.) -2.0 at about $\alpha=87^\circ$ and then decreased for values of $\alpha > 87^\circ$.

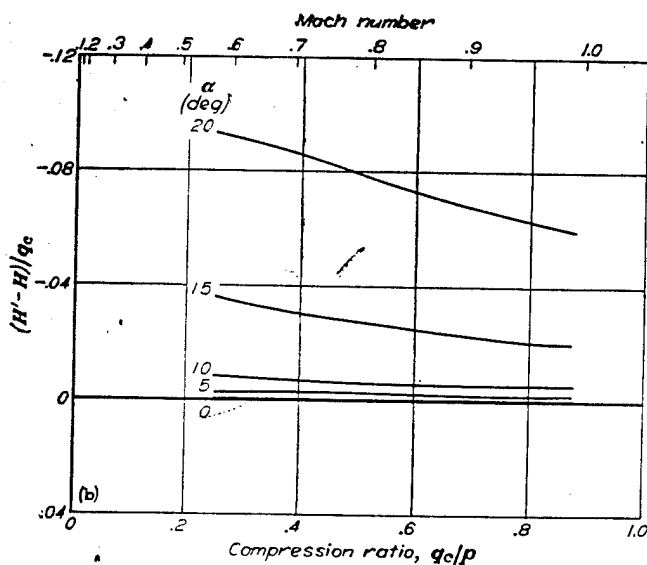
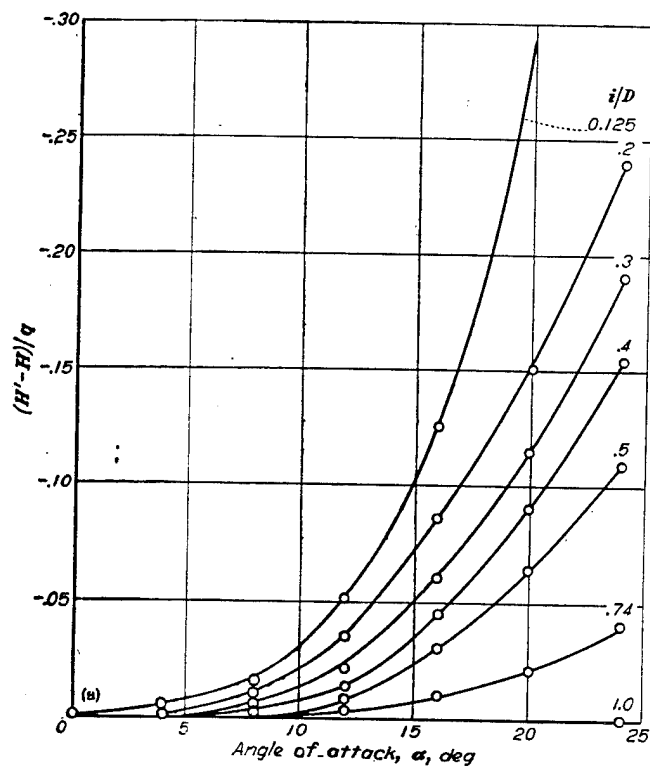

(a) Variation with orifice ratio and angle of attack. Data from reference 20.

(b) Variation with Mach number and angle of attack; $\frac{i}{D} = 0.3$. Data from reference 22.

FIGURE 2.—Total-pressure defect for hemispherical nose.

For applications in which a large change in angle of attack of the pitot head is expected and especially for research purposes, shielded total-pressure heads, which give zero total-pressure defect up to angles of attack of 35° , are available (reference 19). For many uses a simpler form of tube would be suitable; that is, one that makes use of the small rate of increase of total-pressure defect with angle of attack as i/D approaches 1, as shown in figure 2 (a).

Effect of turbulence.—Reference 15 indicates that the presence of turbulence in the air stream causes values of H' to be less than the true value H . As turbulence may be considered, in part, as a change in the local angle of flow, the data of references 15 and 20 indicate that the total-pressure error would decrease with an increase in the ratio i/D . Although often important in wind tunnels, such turbulence is not a source of error in airspeed measurements.

Effect of drain holes.—The error in total-pressure measurements as a result of drain holes depends on the size and location of the holes. References 23 and 25 show that the error introduced by such holes can be about $\frac{1}{2}$ percent at low speeds and decreases with an increase in speed.

STATIC-PRESSURE HEADS

The static orifices in the wall of a pitot-static tube do not, in general, develop the true static pressure at the head location because of disturbances associated with the flow over the head. The error is closely associated with the dimensions and design of the head, Mach number, angle of attack, changes in configuration during use, and Reynolds number.

Effect of dimensions and design.—Theoretical analysis for incompressible flow (reference 18), confirmed by experiment (reference 14), indicates that the local static pressure is less than free-stream pressure for a distance of about 16 diameters back of the nose. Use is often made of the interference of a supporting streamline strut or of a collar back of the orifices to increase the pressure at the static holes. The strut or collar is an integral part of the head and is so proportioned that true static pressure is more nearly approached. The effectiveness of such compensation may vary with Mach number, and new designs should always be tested in a wind tunnel over the maximum Mach number range for which they will be used.

Early investigations of the effect of dimensions (references 14, 15, and 20) have been extended by the British to Mach numbers of 0.95 and are summarized in figure 3. Figure 3 (a) shows the pressure at static orifices located at a distance x_N back of an ogival nose over a range of Mach number from 0.3 to 0.95. Figure 3 (b) shows the effect of a 43-percent collar at a point x_C behind the static holes, and figure 3 (c) shows the effect of placing a mounting stem of thickness $D_s = 0.9D$ at various distances x_S behind the static holes.

Cross-plotting of the data of figures 3 (a), 3 (b), and 3 (c) shows that at constant values of M the effect of orifice location relative to both nose and collar varies directly with $(1/x_n)^2$ and $(1/x_c)^2$, respectively, and the effect of a stem varies directly with $1/x_s$.

Effect of Mach number and angle of attack.—Figure 3 (d) and figure 3 (f) illustrate the complexity of the interaction of changing direction of flow and the effects of high-speed flow. The pressure increase at Mach numbers larger than 0.8 exhibited by the Prandtl-type tube in figure 3 (d) is associated with shock due to flow over the nose (first evidenced in schlieren photographs at $M=0.7$), but the drop at $M=0.97$ is associated with the fact that the shock wave moves to a location behind the static orifices. Theory (reference 21) indicates that, by use of the nose shape known as a Rankine ovoid, the effects of shock displayed in the head, the characteristics of which are given in figure 3 (d), are delayed to larger values of free-stream Mach number.

Change of static defect with angle of attack is in part a function of the diameter of the static orifices and of any interior constrictions which may be built into the static-pressure head. Common procedure is to have the static orifices open into a small settling chamber in which any turbulence or random changes of equilibrium associated with flow through the orifices when the direction of flow is not parallel to the axis of the head may be neutralized. The tube for transmitting the static pressure opens into this chamber. In such designs, if the static orifices are less than 0.20 inch in diameter, the energy losses tend to diminish the static-pressure errors due to the angle of attack. The orifices of the tube for which curves are plotted in figure 3(d) are in the form of a circumferential slot of width $0.1D$; whereas the twenty orifices of the tube for which curves are plotted in figure 3(f) are holes of 0.025-inch diameter. For service tubes exposed to spray, circumferential slots are often used since their larger dimension reduces the tension for rupture of any water films that form.

Unless the static orifices are symmetrically placed and at least eight in number, the static-pressure error will vary with the plane of the inclined flow (reference 20). For a static-pressure head with the static orifices concentrated on the upper and lower surfaces, the static-pressure error is substantially constant over a range of pitch of $\pm 7.4^\circ$ but is not constant for an equivalent range of yaw.

When airspeed is measured under laboratory conditions under which the angle of attack of the head can be controlled, calibration curves such as are shown in figure 3 are of use but in flight they do not dispense with the necessity of making a flight calibration when the angles of attack and yaw and body interference effects are not known. The use of free-swiveling static heads does not eliminate the necessity of calibrating for interference effects.

Effect of small changes in configuration.—The tube must be smooth and free from burrs in the vicinity of the static orifices. For two tubes of the same manufacture which differed only in that some of the metal plate near the static orifices of one had been stripped, the tests of reference 23 indicate a change in static defect from 4 percent to 2 percent (a 2:1 ratio) over the entire speed range. Small changes in configuration which may occur during use can, therefore, have a marked effect on the calibration of a static-pressure head.

Effect of Reynolds number.—Tests (reference 17) have shown that a Reynolds number greater than 2300 (when the linear dimension is the diameter of the static head) is essential if the measured static pressure is not to be subject to scale effects. This fact is shown in figure 3 (e) where the cross-hatched area represents the region of scatter in the values of static defect apparently associated with some instability of flow. In figure 3 (e) the data as given in reference 17 for tube calibration factor K , which equals q/q' have been replotted by means of the relation $\frac{p'-p}{q} = \frac{K-1}{K}$. The variation of static defect with Reynolds number indicates a lower limit at high altitude for the diameter of static heads and rakes for wake surveys.

SERVICE PITOT-STATIC TUBES

With commercially available pitot-static tubes, differential or impact pressure could be measured with great accuracy if interference effects of the airplane and lag and instrument errors were not present. Pressure defects obtained in calibrations at zero angle of attack of two standard pitot-static tubes (reference 23) are given in figure 4. In figure 4 the total-pressure defect is entirely due to the drain holes.

The defects at other angles of attack can be expected to vary from those given in figure 4. Since these tubes have ratios i/D of about 0.3, the defect in H would be negligible (less than $\frac{1}{2}$ percent) for angles of attack up to at least 6° or 8° . Since the nose shapes are elongated, the total-pressure defect at greater angles of attack would undoubtedly be smaller than the data for hemispherical noses would indicate (fig. 2), but published detailed calibrations are lacking. Errors in total pressure can be expected with these heads, however, when used in a leading-edge position.

Uniform static defect over a wide range of Mach number results from the addition of a collar or fin that compensates for the negative defect associated with flow over the nose; the resultant positive static defect amounts to 2 or 3 percent of q_c . Although this defect could introduce an error of 1 to 1.5 percent in Mach number, the corrections described in the section entitled "Flight Calibration of Airspeed and Temperature Installations" allow for it.

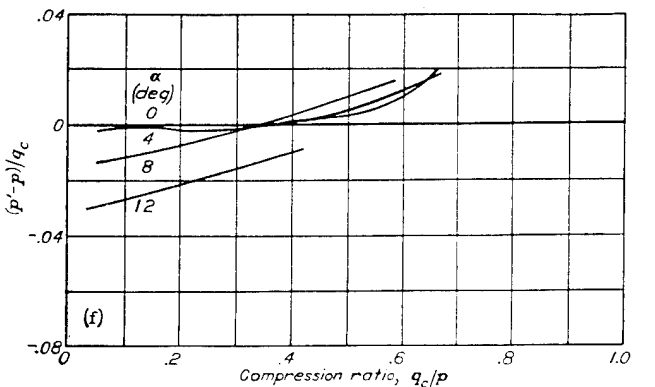
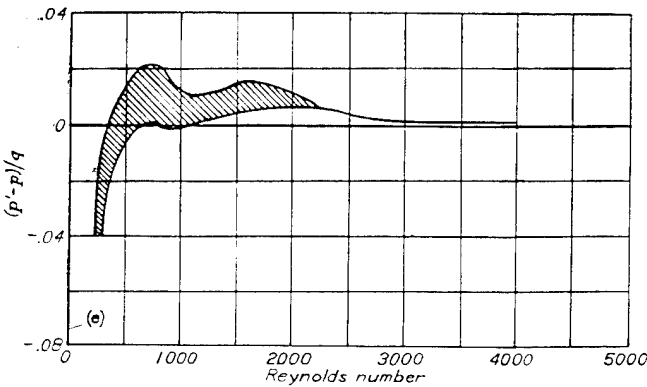
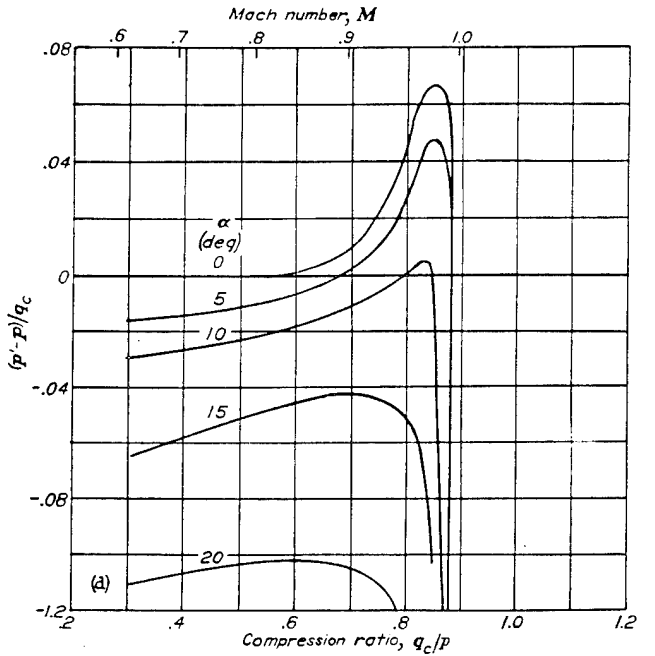
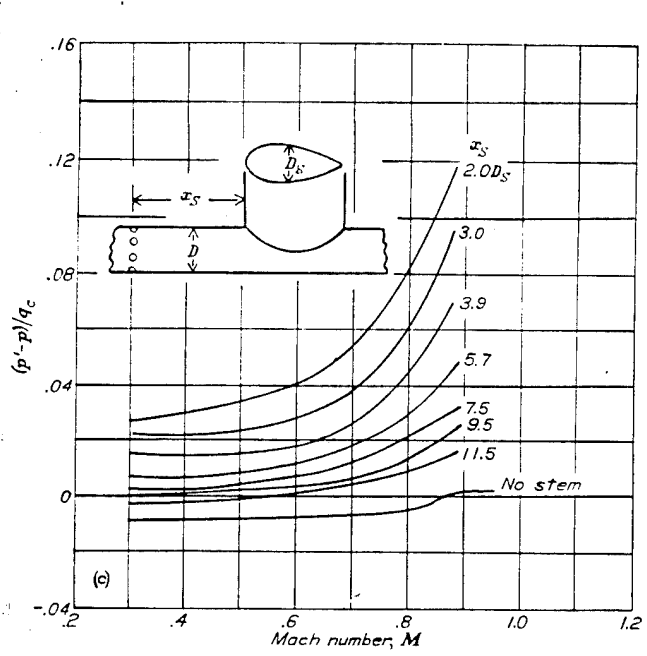
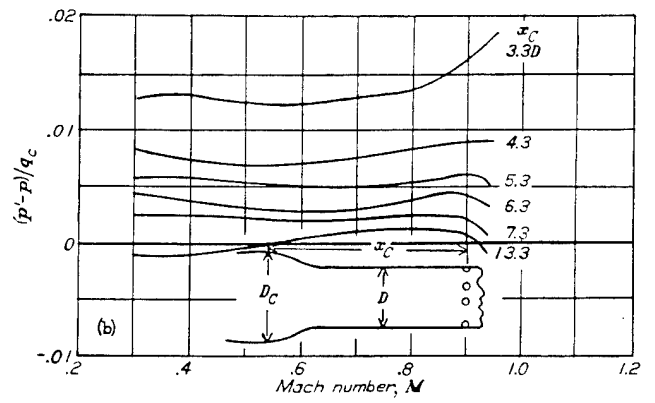
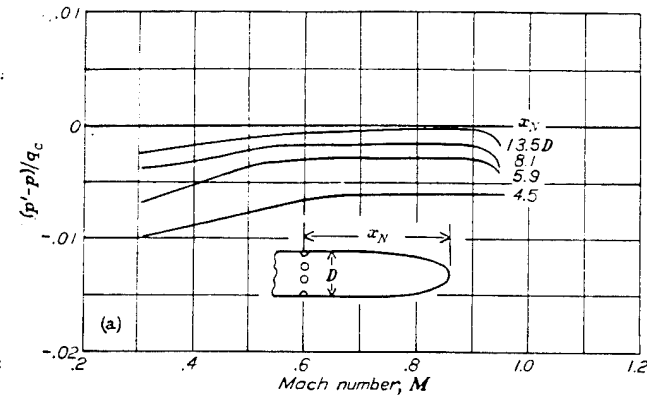

(a) Static orifices at distance x_N behind orignal nose.
 (c) Mounting stem at distance x_S behind static orifices. $x_N=3.4D$; stem thickness $D_S=0.9D$.
 (e) Reynolds number. Reference 17.
 (b) Collar at distance x_C behind static orifices. $D_C=1.43D$; $x_N=13.8D$.
 (d) Angle of attack for hemispherical nose. Prandtl-type tube. $x_N=3D$; $x_S=10D_S$; reference 22.
 (f) Angle of attack for semiellipsoidal nose. $x_N=3.5D$; $D_S=0.25D$; $x_S=20D_S$; reference 23.

FIGURE 3.—Variation of static-pressure defect of pitot-static tubes with tube construction, Mach number, angle of attack, and Reynolds number. All dimensions are based on tube diameter.

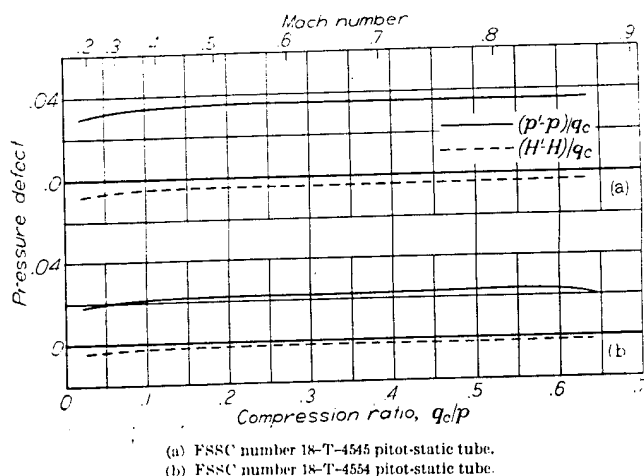

(a) FSSC number 18-T-4545 pitot-static tube.
 (b) FSSC number 18-T-4554 pitot-static tube.
 FIGURE 4.—Typical total- and static-pressure defects of two airspeed heads at zero angle of attack. Data from reference 23.

THE FIELD OF FLOW ABOUT AN AIRFOIL

The accuracy required in each of several measured quantities in order to achieve a specified accuracy in airspeed has been discussed. This discussion was followed by a summary of the available material on the deviations in pressure measurement to be expected from the isolated total- or static-pressure head. In the following section the field of flow about an airfoil is discussed and available data are summarized in order that qualitative estimates may be made of the errors from this cause that must be expected and allowed for when pitot-static devices are attached to an airplane.

The direction and velocity of the flow about an airfoil vary, in general, from point to point with the shape and thickness ratio of the airfoil, with the lift coefficient, and with the Mach number. As a result of these variations, the static-pressure error associated with the flow can be expected to vary; in addition, both static- and total-pressure heads may be in error because of inclination of the flow with respect to the head.

The results of a number of theoretical and experimental investigations of the flow in the vicinity of airfoils are available in references 26 to 29 and in reference 31. These results are based on the theory of incompressible flow and low-speed wind-tunnel tests and are summarized in figures 5 and 6 to which are added unpublished results from an investigation at the Langley Laboratory of the flow in the vicinity of a Joukowski airfoil for a range of values of c_l from 0.2 to 0.8. The data presented in references 26 to 28 in terms of the ratio of the local velocity v to the free-stream velocity V and the local direction of flow relative to the wind direction or tunnel axis have been modified in figures 5 and 6 as follows:

(a) Values of $\frac{\Delta p}{q} = 1 - \left(\frac{v}{V}\right)^2$ have been substituted for the velocity ratio on the velocity contours.

(b) The angle of attack to the nearest degree has been added to the angle of flow to give the angle ξ between the local flow at any point and the airfoil chord.

(c) Some contours have been omitted for clarity.

Some variation is to be expected in the value of $\Delta p/q$ with Mach number. The results of reference 34 show, however, that ahead of the wing the variation is small and also that at a point 1.3c ahead of a 15-percent-thick high-speed airfoil section the value of $\Delta p/q_c$ is within the limits of experimental error for $M \leq 0.8$.

LOCATION OF STATIC HEAD

The ideal location for the static head would be one for which no installation correction is necessary throughout the flight range. A good practical location is one with a small constant installation error. Figures 5 and 6 show that no such location exists in the underwing region. It is more nearly approached for wings with a convex lower surface, but the effects of shock, including a large increase in static pressure, have indicated the need for other locations for the static- and total-pressure orifices. For research testing, a boom-mounted static head in front of the leading edge of the wing approaches the characteristics of the ideal location most closely. Even with a boom of 1 chord, however, some variation of local static pressure with c_l may be expected. Although variations of $\Delta p/q$ and angle of flow with c_l may be small and decrease with increasing length of boom, some control of the static defect is possible by choice of the vertical displacement of the static head relative to the chord extension. If, for example, a location is chosen which has zero defect at a high value of c_l , the magnitude of $\Delta p/q$ increases at a low value of c_l . Since low values of c_l are ordinarily associated with high speed and high values of q , the actual departure from free-stream static pressure expressed in inches of water or feet of pressure altitude may be large. On the other hand, if the static head is located so that $\frac{\Delta p}{q} = 0$ at $c_l = 0$, small departures from free-stream values result even though $\Delta p/q$ may increase at larger values of c_l .

Spanwise location of the static head is in part determined by structural considerations, a location between 0.2 and 0.5 semispan inboard of the wing tip usually being chosen. This choice is based partly on the general requirement that the measuring head should be so located as to be free of the effects of a source of energy such as the propeller, and on the fact that the boom can be shorter when located farther outboard on a tapered wing. There is evidence in reference 29 that a location ahead of and 0.043 semispan outboard of the wing tip would also give satisfactory results with a still shorter boom.

Flight calibration of the airspeed installation is needed regardless of the location selected for the static head. The variation of $\Delta p/q_c$ in the field of flow about a wing is such that this calibration is greatly simplified, however, if a static head and its associated mount are used that have an inherent static-pressure defect $(p' - p)/q_c$ which, if not zero, is essentially small and constant over the entire range of Mach number for which they will be used. Use of such a head allows more simple and precise extension of airspeed calibrations secured in level flight to high speed, high lift, and high load factor.

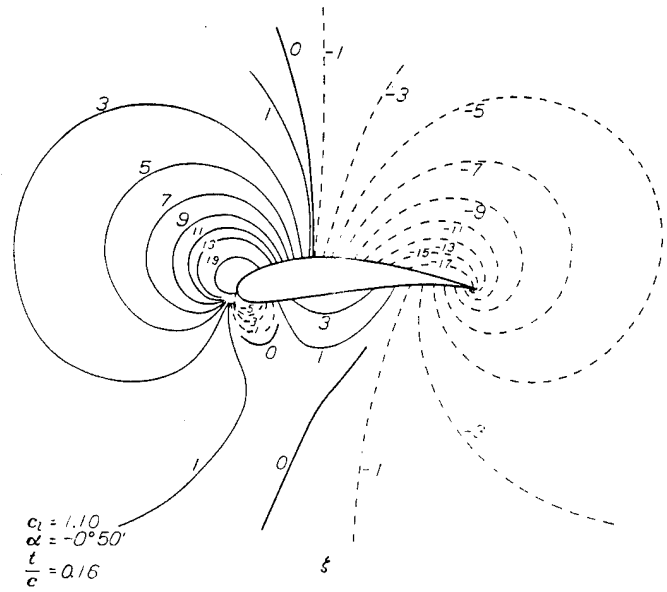
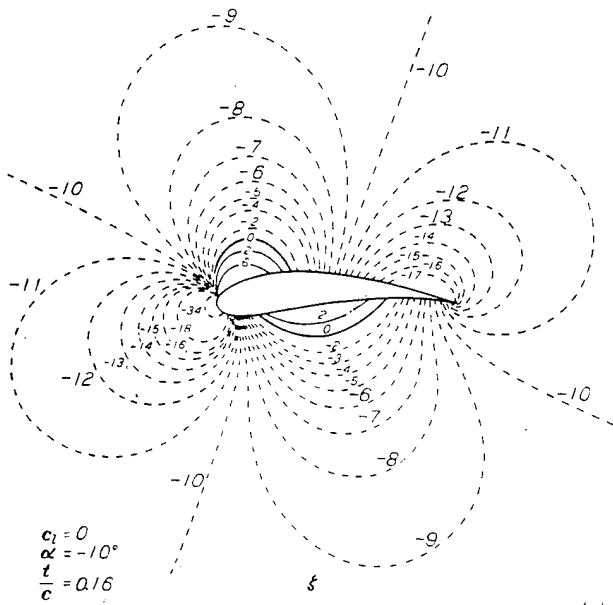
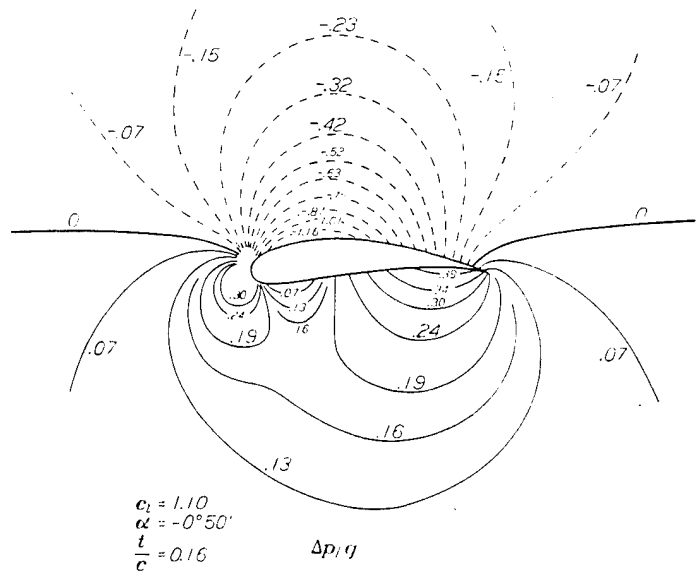
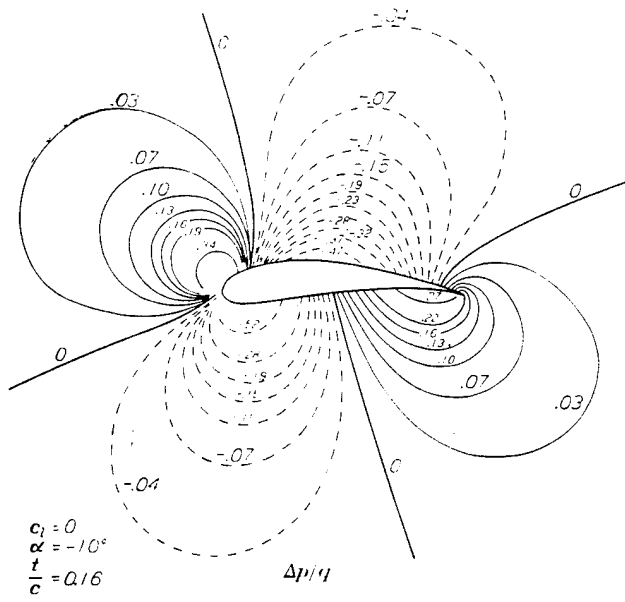

(a)

(a) Contours of equal static-pressure defect $\Delta p/q$ and equal angle of flow relative to airfoil chord ξ . Data from reference 28.
 FIGURE 5.—The field of flow about a Joukowski airfoil from calculations. Variation with c_l .

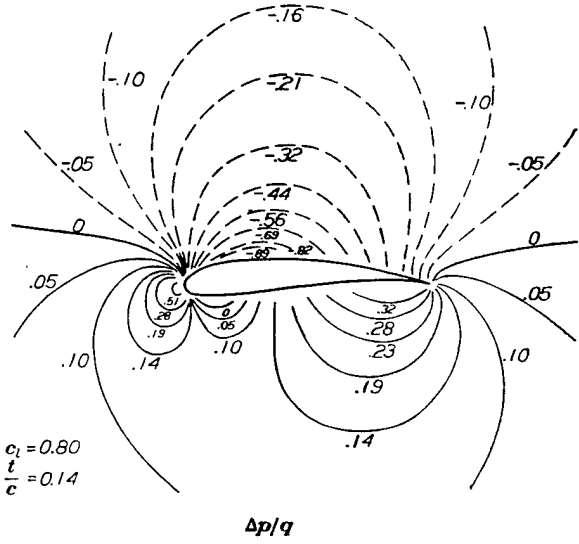
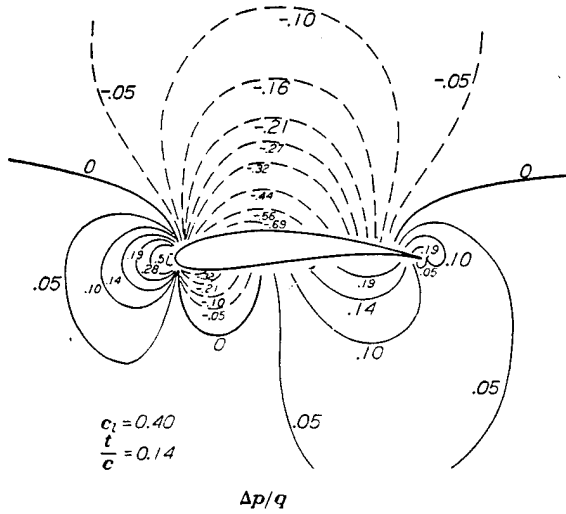
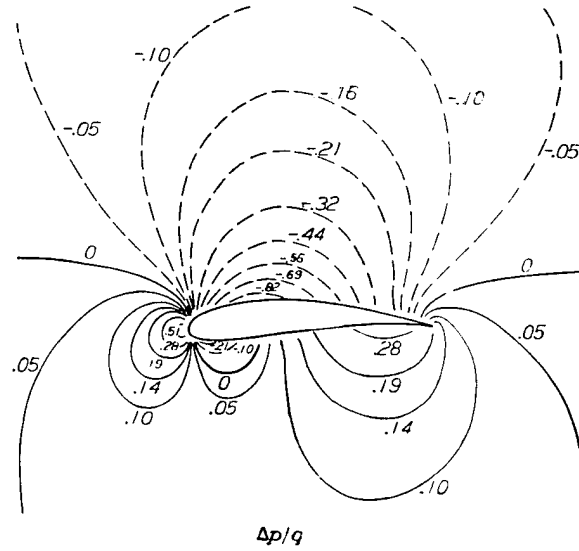
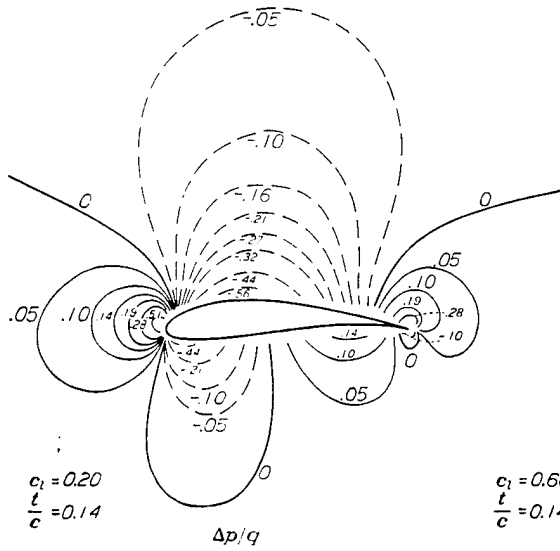

(b)

(b) Contours of equal static-pressure defect $\Delta p/q$.
FIGURE 5.—Concluded.

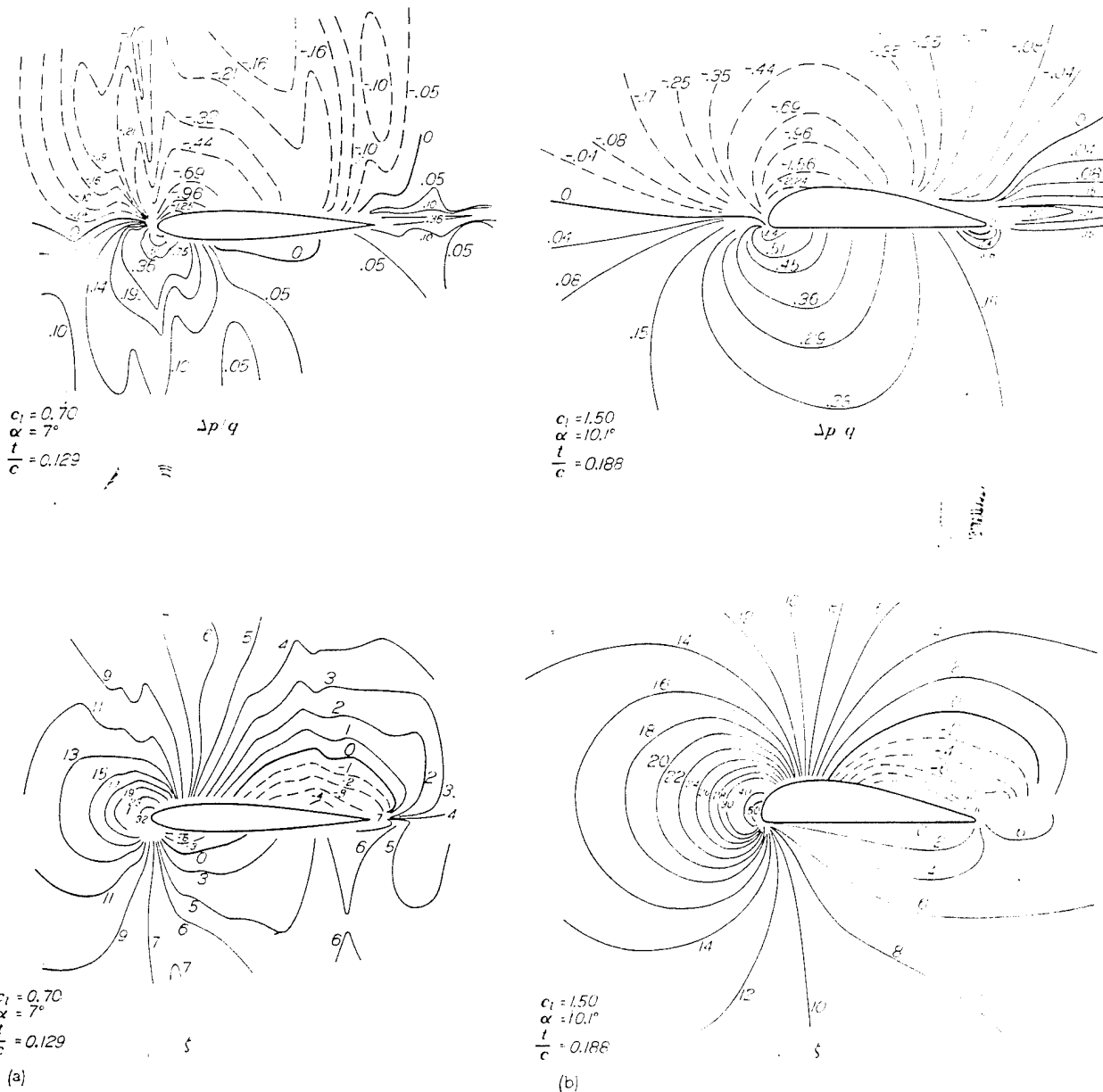

(a) RAF 30 symmetrical airfoil (reference 27).
(b) Nonsymmetrical airfoil (reference 26).
FIGURE 6.—Contours of equal static-pressure defect $\Delta p/q$ and angle of flow relative to airfoil chord ξ from measurements.

LOCATION OF TOTAL-PRESSURE HEAD

Total-pressure heads should be located outside a region of energy change such as the slipstream or wake. For multi-engine airplanes a location at the nose is satisfactory. An underwing location is especially suitable when large changes in c_l are encountered since, as shown in figures 5 and 6, the change in angle of flow at the head is small. The underwing of a typical high-speed fighter airplane is, however, subject to shock at high values of Mach number and, as shown in reference 36, the resulting loss of total pressure extends a

considerable distance below the wing surface. Although the head could be placed forward of the shock location, if the speed of sound is exceeded locally shock occurs at the total-pressure orifice and the assumption of accurate total pressure is no longer justified. Since total-pressure values, when in error, are too small, they will tend to cause the indications of both airspeed and Mach number to be too small. Since the effects of shock on total pressure do not extend upstream, a location forward of the leading edge is desirable for any airfoil for which the local flow velocity exceeds the speed of sound.

Large changes in angle of flow may be encountered in the region forward of the wing leading edge. Total-pressure heads for this location must, therefore, be designed for satisfactory operation at large angles of attack in order to be a reliable source of total pressure under all conditions of flight. As shown in figures 5 and 6, at the station $0.1c$ ahead of the leading edge the change in angle of flow for a change in c_l from 0 to 1.0 is of the order of 40° to 50° and decreases to 17° at $0.55c$ and 13° at $1.0c$. The angle of flow relative to the orifice of a leading-edge total-pressure head may also be estimated by the following relation based on the flow around a flat plate:

$$\zeta = \frac{90C_L}{\pi^2} \sqrt{\frac{1 + \frac{L}{c}}{\frac{L}{c}}} \quad (10)$$

where ζ is the local angle of flow relative to the chord at a point L/c chords ahead of the leading edge along the chord extension, and C_L may be considered the airplane lift coefficient.

LOCATION OF STATIC VENTS

For flight research, a suitably located and calibrated static head is the standard source of free-stream static pressure. A frequently used auxiliary or alternate source of static pressure is the static vent (flush static-pressure orifice). A static vent must be calibrated against a standard source in flight, but once a suitable location is found, identical installations on other airplanes of the same type usually have the same calibration. For the convenience of the pilot it is customary in service installations to select a location giving constant indicated-airspeed error, that is, one for which to a first approximation

$$\frac{p' - p}{\sqrt{2\rho_0 q}} = \Delta V_i = \text{Constant}$$

A promising location for the static vent may often be found by wind-tunnel tests of a model of a new airplane; the final location must be selected by trial-and-error test in flight. For conventional airplanes a suitable location is usually found near the geometric center line of the fuselage, forward of the leading edge of the horizontal stabilizer a distance equal to 0.1 to 0.2 of the over-all length of the airplane. Locations on opposite sides of the fuselage, not necessarily symmetrical because of slipstream effects, should be used if possible, and the static-pressure line should be connected to the midpoint of a line connecting both vents. Such a dual-vent system is less subject to sideslip and slipstream effects. Checks should be made for the effect of flaps and for freedom from the effects of movable armament. For multiengine airplanes, a dual-vent system can sometimes be located on the nose, forward of the propeller plane.

LAG IN PRESSURE-MEASURING SYSTEMS

In addition to the pressure deviations at the pressure-measuring instrument due to the geometry of the pitot-static arrangement and interference from neighboring bodies,

errors due to lag may occur. When changing pressures are involved, both the finite speed of pressure propagation and the pressure drop associated with flow through the tubing introduce a lag in pressure at the indicating or recording end of the measuring system. In some instances the error can be serious. In dives, for example, lag tends to make the pressure altitude at any time too large, whereas the airspeed may be made either too large or too small in accordance with the relative amounts of lag in the total-pressure and static-pressure systems. Furthermore, airspeed errors throughout a dive and pull-out may not always be in the same direction.

As long as lag errors are smaller than the other possible errors in the instrumentation, recorded or indicated pressure may be assumed equal to actual pressure in the interpretation of flight data. On the other hand, in attempts to attain greater altitude, speed, and acceleration, lag errors which are too large to be acceptable may be encountered.

The purposes of this section are: to discuss the errors which can be introduced by pressure lag, to summarize the methods for evaluating the lag constant, to establish criteria and methods for minimizing the errors due to lag, and to outline a method for correcting flight records for the effects of lag, should that be necessary.

MATHEMATICAL THEORY

A general mathematical treatment of the response of a pressure capsule and its connecting tubing to a pressure change includes simultaneous second-order partial differential equations involving the physical properties of the air in the measuring system, the viscous damping at the walls of the tubing, and the characteristics of the measuring instrument. Even when the system is simplified by neglecting the mechanical parts of the instrument, the mathematical treatment is not simple. In many respects, however, the performance of a typical airspeed system is similar to that of a damped oscillator of one degree of freedom in that there are conditions under which resonance may take place (system underdamped) and other conditions under which it is not possible for resonance to occur (system critically damped or overdamped). The mathematics of such systems is well-known. Reference 42, in which a generalized recording instrument is considered, lists solutions for equations of the type

$$m \frac{d^2 p'}{dt^2} + R \frac{dp'}{dt} + \frac{p'}{C} = \frac{p(t)}{C} \quad (11)$$

for typical values of the equivalent mass m , viscous damping R , and elastic constant $1/C$, and for different types of forcing function $p(t)$. Although such solutions cannot be easily used to find the true pressure from the indicated pressure, they are useful in showing the general nature of the response of an airspeed system under different operating conditions.

Airspeed systems may be resonant (underdamped) when tubing is short and the altitude low. If buffeting or oscillatory pressures are being measured, an underdamped system will exaggerate the amplitude of the oscillation although

mean values are usually given correctly. Whenever the value of a steady pressure changes to some other value, a damped transient oscillation is introduced. Solutions of equation (11) indicate, however, that for pressures changing at a constant rate the rate of pressure change is reproduced correctly after the transient is damped out and the indicated pressure lags behind the true pressure by a time dependent upon the product of R and C for the system.

For most conditions under which airspeed is measured, the system is critically damped or overdamped. In these instances too, for constant rates of pressure change after the transient has died out, the indicated pressure lags behind the true pressure by an amount determined by the product RC . Thus in all cases, for constant rates of pressure change, the system behaves as if the mass were zero and could be described by the relation

$$RC \frac{dp'}{dt} + p' = p(t) \quad (12)$$

The assumption that equation (12) can be applied to an airspeed system for conditions other than constant rates of change leads to a simple method of correcting pressure data. This method depends only on the indicated pressure p' , the rate of change of indicated pressure, and the product RC which is the "lag constant" λ .

Another factor which is often important in airspeed measurements may be termed the "acoustic lag" τ . A pressure disturbance at one end of a tube does not reach the other end until a time has elapsed equal to the length of the tube divided by the speed of pressure propagation (sound) in the tube. Thus, in general,

$$\tau = \frac{L}{a} \quad (13)$$

A satisfactory approximation for $\frac{3}{16}$ -inch inside-diameter rubber tubing is that $a = 1000$ feet per second.

The acoustic lag acts simply as a shift in phase; therefore, a more generally applicable form of equation (12) is

$$p(t) = p'(t + \tau) + \lambda \frac{dp'(t + \tau)}{dt} \quad (14)$$

Equation (14) states that the true pressure at any time t is equal to the indicated pressure at the corresponding time $t + \tau$ plus the product of λ and the rate of change of indicated pressure at the time $t + \tau$.

The applicability of the approximations involved in equation (14) to pressure measurements in flight is illustrated by an extreme case in figure 7. The lower solid line is the recorded pressure $p'(t)$ during a pressure surge of 60 inches of water per second or a simulated dive at a rate of 11,000 feet per second from a base pressure altitude of 35,000 feet as recorded by an NACA airspeed recorder through 80 feet of $\frac{3}{16}$ -inch inside-diameter rubber tubing. The upper solid line is the true pressure $p(t)$ as measured simultaneously by a similar recorder with no tubing. Note that the indicated-pressure rise began τ seconds after the start of the

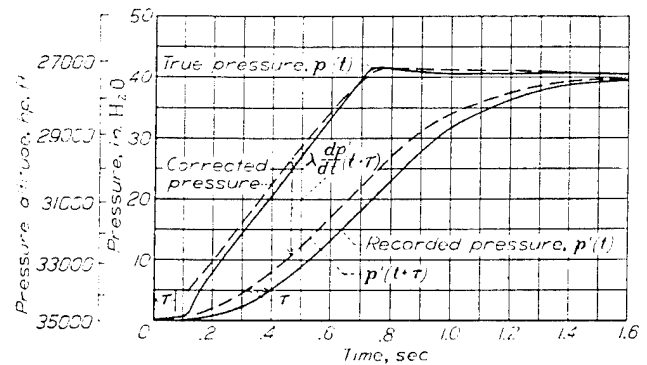

FIGURE 7.—Difference due to lag between true and recorded pressure and result of making correction for lag by use of equation (14).

true-pressure rise. The curve labeled $p'(t + \tau)$ represents the indicated pressure shifted in phase τ seconds toward the origin. The curve labeled corrected pressure was obtained by adding $\lambda \frac{dp'(t + \tau)}{dt}$ to $p'(t + \tau)$, the value of λ being determined by the methods outlined in the section entitled "Determination of Lag Constant by Experimental Methods." The nature of the original pressure change has been determined with satisfactory precision from the recorded pressure and a knowledge of the system. If the acoustic lag is small, the phase shift represented by the dashed line could be omitted and equation (14) becomes (as in references 40 and 46)

$$p(t) = p'(t) + \lambda \frac{dp'(t)}{dt} \quad (15)$$

As shown in reference 46, equation (12) or (15) can be derived and the lag constant λ can be simply computed on the basis of the assumptions that pressure changes take place according to the adiabatic law, that the Hagen-Poiseuille law describes the viscous forces (and thus the flow is laminar), that the distributed resistances and volumes of the system can be lumped together in a total resistance R and a total capacitance C , and that m and τ may be ignored. The following relations then apply:

$$\lambda = RC \quad (16)$$

$$R = \frac{32\mu L}{D^2 A} \quad (17)$$

$$C_{\text{rigid}} = \frac{V}{\gamma p} \quad (18)$$

$$C_{\text{elastic}} = \frac{c_0 + B\gamma p}{\gamma p} = \frac{V'}{\gamma p} \quad (18a)$$

Equation (18) applies to rigid containers and equation (18a) applies to elastic containers such as aneroid capsules for which the volume may be taken as a linear function of the pressure:

$$v = v_0 + p \frac{dv}{dp} = v_0 + Bp$$

The equivalent rigid volume—that is, the volume of a rigid container having the same capacitance as the elastic container—can be expressed as follows:

$$v_c = v_0 + B\gamma p \tag{19}$$

Since

$$B = \frac{dv}{dp} \tag{20}$$

in the limiting case, equation (18a) reduces to equation (18) as B approaches zero.

In the application of relations for R and C to a particular installation, values of p and μ should be used which correspond to the pressure and temperature at which measurements are made. For comparison of pressure-measuring systems it is convenient to use values of p and μ corresponding to sea-level conditions in the standard atmosphere, in which case the lag constant is denoted by λ_0 . A consistent system of units must be used. Where necessary to distinguish between dimensions of tubing and aneroid capsule, the subscripts t and a , respectively, are used and the subscript c refers to the air space in the case surrounding the capsule.

The constant γ is included in equations (18), (18a), and (19) through the assumption that pressure changes take place adiabatically. In the absence of experimental data on the speed of sound in tubing of small diameter, the isothermal relation—that is, $\gamma = 1$ (as used in reference 40)—which makes use of a diminished speed of sound, can be assumed to apply to such tubing since the amount of gas next to the inner surface is a large proportion of the total amount. With tubing of $\frac{3}{16}$ -inch inside diameter, unpublished tests at the Langley Laboratory indicate that the adiabatic relation more nearly applies for the pressure changes encountered in airspeed measurement.

For a pressure measuring instrument and the connecting tubing, the general relation $\lambda = RC$ becomes

$$\lambda = R_t(C_t + C_a) = \frac{32\mu L}{D^2 A} \left(\frac{v_t + v_a}{\gamma p} \right) \tag{21}$$

In the development given in reference 40, v_t has been neglected as being small compared with v_a . This solution leads to an expression in which λ varies inversely as the fourth power of the tubing diameter. Such an expression does not apply to typical NACA recording instruments or others of small volume or to standard panel instruments with long connecting tubing.

Substituting LA for v_t and $v_a LA/A$ for v_a in equation (21) results in the following equation for use with aircraft instruments:

$$\lambda = \frac{32\mu L^2}{D^2 \gamma p} \left(1 + \frac{v}{LA} \right) \tag{22}$$

In the application of equation (22), since v/A has the dimension length, the instrument volume can be conveniently

expressed as v/A feet of equivalent tube length. For instruments of small volume a convenient approximation for equation (22) is obtained by ignoring the parenthetical part of the expression and substituting for L^2 the value $\left(L + \frac{v}{A} \right)^2$.

(See reference 46.) The value v should be determined by equation (19) with allowance for the elasticity of the capsule. Often, as stated in reference 40, no allowance need be made for elasticity, but for capsules of high sensitivity the increase in effective volume due to the term $B\gamma p$ may be large as shown in the following table:

Rated capsule sensitivity (in. H ₂ O)	Equivalent rigid volume at sea level (ft ³)	Equivalent rigid volume at 30,000 ft (ft ³)	Equivalent tube length at sea level (ft of $\frac{3}{16}$ -in. I. D. tubing)	Equivalent tube length at 30,000 ft. (ft of $\frac{3}{16}$ -in. I. D. tubing)
5	27.5 × 10 ⁻⁴	9.0 × 10 ⁻⁴	14.4	4.7
10	14.3	5.1	7.5	2.7
20	7.8	4.1	4.1	2.1
30	5.6	2.5	2.9	1.3
50	3.8	2.0	2.0	1.0
75	3.0	1.7	1.6	.9
100	2.5	1.6	1.3	.8

Values in the foregoing table were computed from equation (19). The constant B is computed from the capsule diameter ($1\frac{1}{16}$ in.) on the assumption that the rated pressure corresponding to a deflection of 0.040 inch at the center of the capsule causes it to expand as a cone. The value 1.2×10^{-4} feet³ for the volume v_0 is applicable to NACA instrument capsules. For the case surrounding the capsule $v_0 = 7.5 \times 10^{-4}$ feet³.

Values of lag constant at sea level.—The value of λ under sea-level conditions for a number of instruments and instrument combinations has been plotted in figure 8 as a function of length of $\frac{3}{16}$ -inch inside-diameter tubing. Values of λ for NACA recording instruments are derived from equation (22) by use of representative values for v_a/A of 1 foot and for v_c/A of 4 feet for the capsule and case, respectively. Values used for the volume of the standard panel instruments are as follows:

Instrument	Volume (cu ft)
Altimeter.....	80 × 10 ⁻⁴
Airspeed indicator:	
Total-pressure side.....	10
Static-pressure side.....	55
Mach meter—static-pressure side.....	100

Approximate values of λ_0 for other tube diameters D can be found by multiplying values of λ_0 (from fig. 8) by the ratio $\left(\frac{3/16}{D} \right)^2$ where the value of D is given in inches.

For use in determining the acoustic lag τ for any length of tubing, the diagonal straight line has been included in figure 8. Values of τ are based on the approximation that the speed of sound in $\frac{3}{16}$ -inch inside-diameter tubing is 1000 feet per second.

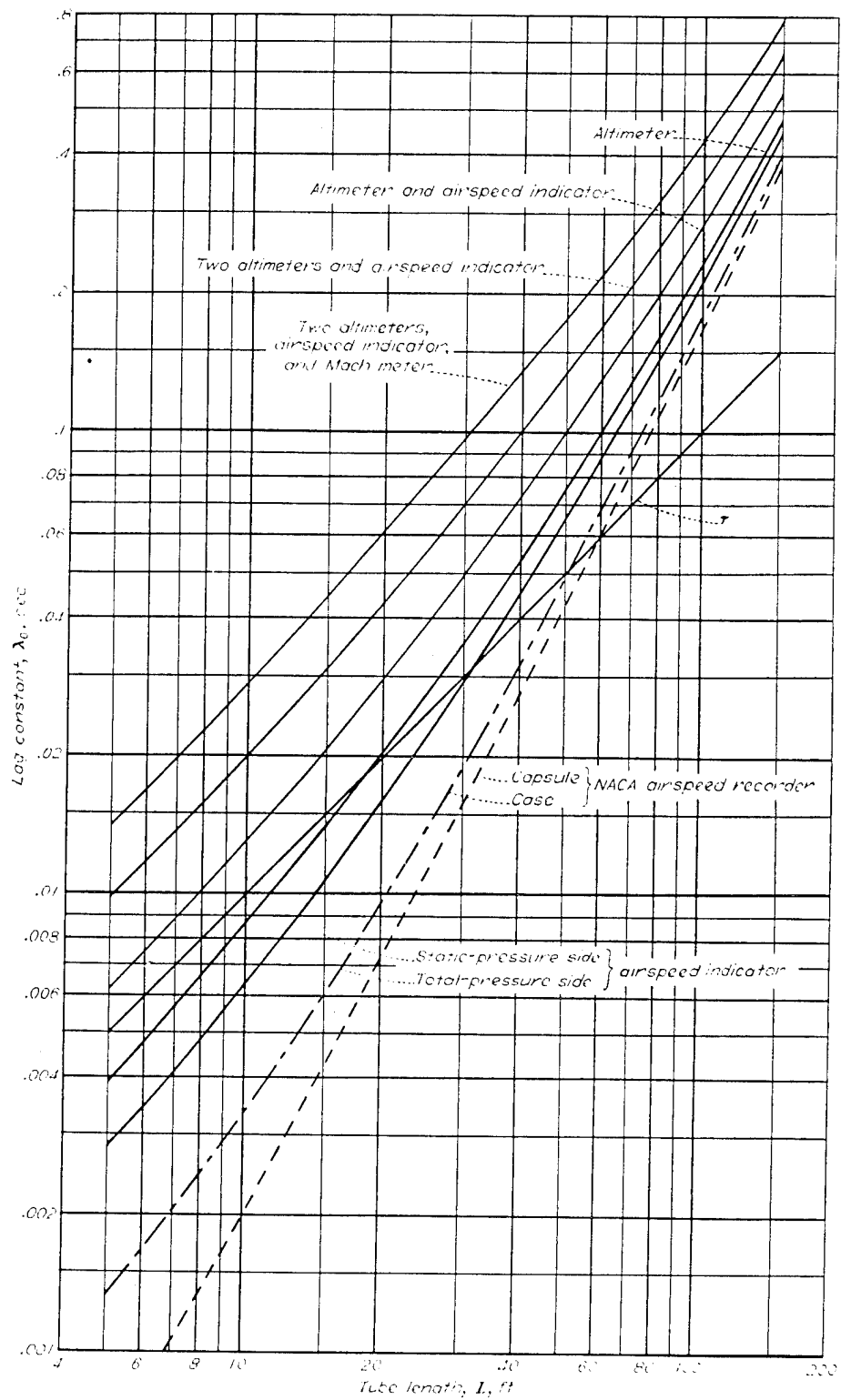

FIGURE 8.—Lag-constant variation with length of 3/16-inch inside-diameter tubing. Sea-level conditions.

Although values of λ_0 for a particular installation as determined from figure 8 may not be directly applicable to surges when the installation is in an underdamped condition, they will be applicable to steady changes of pressure after the transient oscillation has died out. When the value of λ_0 is corrected for the variation of p and μ with altitude, for most airspeed systems $\lambda \geq \tau$; thus the system is either critically damped or overdamped and this corrected value of λ may be applied directly to flight data through use of equations (14) or (15).

Variation of lag constant with altitude.—Equations (17) and (18) for R and C indicate that λ will increase with increasing altitude (decreasing pressure) and that it will decrease with decreasing viscosity (decreasing temperature). Most experimental methods for measuring λ that simulate different pressure altitudes do not involve changes in temperature. The relation between values of λ obtained under such conditions of simulated pressure altitude and the value of λ under standard sea-level conditions can be expressed as

$$\lambda = \lambda_0 \frac{p_0}{p} \quad (23)$$

For flight conditions the relation is

$$\lambda = \lambda_0 \frac{p_0 \mu}{p \mu_0} \quad (24)$$

Values of λ/λ_0 from equations (23) and (24) have been plotted in figure 9 as functions of pressure altitude for the standard atmosphere by using values of viscosity taken from reference 10.

DETERMINATION OF LAG CONSTANT BY EXPERIMENTAL METHODS

Although the lag constants of a total- or static-pressure installation may be calculated with satisfactory accuracy when the geometry of the system and the reference pressure are known, it is often desirable to determine λ by experiment. Methods are available that depend upon measurements of the response when an instantaneous pressure change (step function) of magnitude $|\Delta p|$ takes place or when the rate of pressure change can be controlled. Since λ increases markedly with altitude, laboratory tests are best made under conditions of simulated pressure altitude corresponding to the highest altitude at which flight tests will be made.

Laminar-flow condition.—In the measurement of λ , the basic assumption that the flow is laminar should not be violated. As shown in reference 40 the relation between pressure drop, Reynolds number, and the dimensions of the tubing may be expressed as

$$\frac{D^3 \Delta p}{L} = \frac{32 \mu^2}{\rho} Re \quad (25)$$

Since laminar flow in a straight tube cannot be assumed for

values of Re much greater than 2000, equation (25) may be written as a condition for laminar flow:

At sea level,

$$\frac{|\Delta p|}{L} \leq \frac{7.2 \times 10^{-7}}{D^3} \quad (\text{in. H}_2\text{O/ft}) \quad (26a)$$

At 50,000 feet,

$$\frac{|\Delta p|}{L} \leq \frac{30 \times 10^{-7}}{D^3} \quad (\text{in. H}_2\text{O/ft}) \quad (26b)$$

For $\frac{3}{16}$ -inch (0.0156 ft) inside-diameter tubing the requirement therefore is that the step function *should not exceed 0.19 inch of water per foot of tubing at sea level or 0.8 inch of water per foot at 50,000 feet.*

The limitation expressed in equation (25) can be extended to an arbitrary pressure variation by using the value of Δp from equation (15), by making the conservative substitution of dp/dt for dp'/dt , and by using the value of λ from equation (22) as follows:

$$\frac{dp}{dt} \leq \frac{2000 \mu a^2 A}{D(v+LA)} \quad (27)$$

Whence, at sea level,

$$\frac{dp}{dt} \leq \frac{180 A}{D(v+LA)} \quad (\text{in. H}_2\text{O/sec}) \quad (27a)$$

and for a small capsule volume for which $v \ll LA$,

$$\frac{dp}{dt} \leq \frac{180}{LD} \quad (\text{in. H}_2\text{O/sec}) \quad (27b)$$

In the determination of λ by methods (2) and (3) of the following section, much higher values of dp/dt than those encountered in flight may be used without exceeding conditions for laminar flow.

Theoretical basis for measurement.—Three simple methods of measuring λ are based on the solution of equation (15) for different initial conditions and on the assumption that equation (15) applies exactly to the particular installation. In the measurement of pressure differences or elapsed times it will usually be necessary to allow for τ as outlined in connection with the discussion of figure 7 in the section entitled "Mathematical Theory." The three methods are as follows:

(1) When the applied pressure is changed instantaneously from p_1 to p_2 (step function), the indicated pressure changes as an exponential function of time:

$$\frac{p_2 - p'}{p_2 - p_1} = e^{-t/\lambda}$$

or

$$\frac{p' - p_1}{p_2 - p_1} = 1 - e^{-t/\lambda} \quad (28)$$

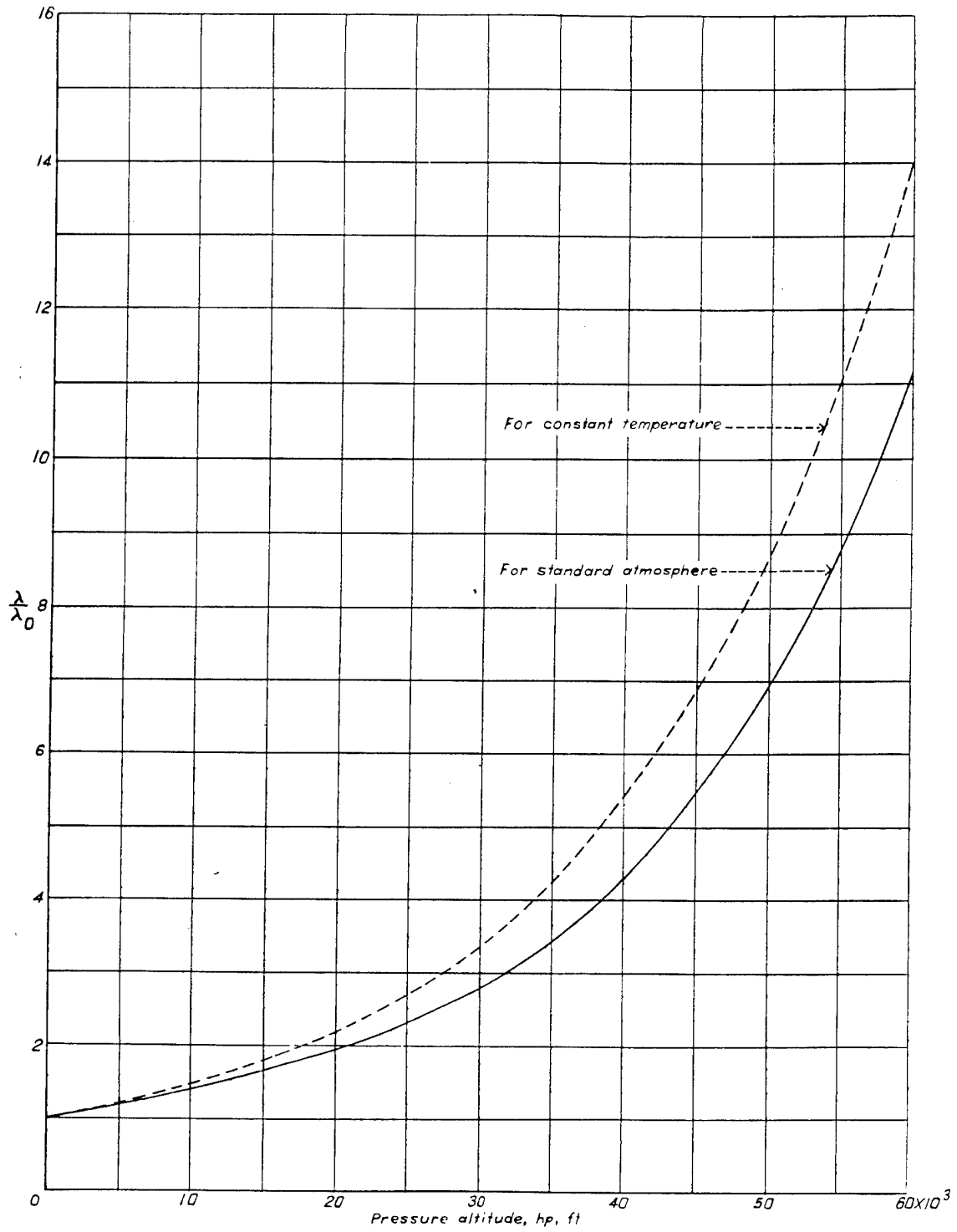

FIGURE 9—Variation of lag in pressure transmission with pressure altitude.

When the applied pressure is change instantaneously, therefore, λ is the number of seconds in which the difference between the indicated and applied pressures is reduced to $1/e$ (0.368) times its initial value.

(2) Solution of equation (15) for a constant rate of change of pressure (references 40 and 42) shows that, when the applied pressure has been changing at a constant rate for a time long enough for conditions to become steady, λ is the number of seconds between the time when the applied pressure attains a given value and the time when the indicated pressure reaches this value.

(3) Equation (15) provides the basis for a method of determining λ ; that is, when the applied pressure is any arbitrary function of time, λ is the difference between applied and indicated pressures divided by the rate of change of indicated pressure $\left(\lambda = \frac{p - p'}{dp'/dt}\right)$.

Any value of lag constant determined on the basis of the foregoing methods is applicable for the temperature and base pressure of the test but should be corrected to sea-level conditions by means of either equation (24) or figure 9 in order to obtain a value of λ_0 for use in the analysis of flight data. All the methods are subject to the limitations that the equivalent mass and acoustic lag of the system have been ignored and that equation (15) has been applied to a system that is a damped oscillatory system. Although usually justified as a practical step in airspeed measurement, the assumption of the applicability of equation (15) is not valid for the transient oscillation observed when a step function is applied to an underdamped system ($\lambda < \tau$). Although a value of lag constant λ can be determined from the oscillation by other methods (see reference 42) it would not differ greatly from a value obtained from equation (22) or figure 8. If, for such a system, lag cannot be ignored as a source of error, either the step function should be applied at a pressure altitude sufficiently great to make the system critically damped or overdamped or method (2) should be used.

Procedure for use with indicating instruments.—For the static line and connected instruments, the lag constant λ_p may be determined by applying a step function Δh_p to the altimeter system and by timing the change in indicated altitude with a stop watch to $1/e$ (0.368) times the initial step value. If Δh_p is 500 feet, λ_p is the time required for a decrease of 316 feet. Alternatively, if sufficient suction is applied at the static orifices to give a reading of 100 miles per hour at the airspeed indicator, λ_p is the time required for a decrease to 61 miles per hour, or one-half the time for a decrease to 37 miles per hour when the suction is suddenly released. For a group of instruments connected by short tubes and then to a common orifice, the volumes are additive, and λ_p determined from any instrument applies to all.

For the total-pressure system, the lag constant λ_H may similarly be found by applying a pressure to the pitot orifice sufficient to give a reading of 100 miles per hour at the airspeed indicator and by timing the change in indication as for the static line. Because of the small volume of the airspeed capsule, λ_H ordinarily is much less than λ_p .

For instruments of small volume with short lines, a step function large enough to ensure accurate measurements sometimes cannot be applied without violating the Reynolds number criterion of equation (26). In such cases, several different step functions can be used and a plot of λ against the size of the step, when extrapolated to zero step, gives a usable result (reference 47).

Procedure for use with photographic records.—The basic procedure for determining λ is to apply to the open end of the system a known suction, to release it, and to determine from the film record the time required for the initial difference to fall to $1/e$ (0.368) times its initial value, or one-half the time to fall to 13 percent of the initial value. The film speed should be as high as possible and provision should be made for placing timing impulses on the record. When necessary, λ may be determined for a range of step function, and extrapolated to zero step.

Use of an arbitrary pressure variation for determining λ requires two instruments that may record either on one film or on separate films with simultaneous time records. The two instruments should be connected to the same source of pressure variation through a Y-connector. One connection, as short as possible, is assumed to measure the true pressure at any instant; the other instrument and connecting line show the effects of both pressure and acoustic lag. Time histories of the two records give values of p , p' , and dp'/dt ; these values substituted in equation (14) or (15) yield values of λ .

CORRECTIONS OF FLIGHT DATA FOR LAG

Pressure-altitude and static-pressure measurements.—During a change of altitude a time record is secured of p' , the measured static pressure. The error due to lag Δp_λ in assuming that p' is equal to p , the pressure at the static pressure orifices, may be written

$$p' - p = -\lambda_p \frac{dp'}{dt} = -\lambda_p \frac{\lambda}{\lambda_0} \frac{dp'}{dt} = \Delta p_\lambda \tag{29}$$

Equation (29) shows that the error is directly proportional to dp'/dt and increases with altitude. In the evaluation of Δp_λ for the correction of pressure data, the rate of pressure change dp'/dt along with p' is determined from the flight records. Values of λ/λ_0 (fig. 9) corresponding to p' instead of to p may usually be used without introducing errors greater than the uncertainty in the correction itself. Sometimes a method of successive approximations must be used.

A chart such as figure 10 offers a simple method of evaluating equation (29). The lines that represent the term λ/λ_0 in equation (29) have been labeled with the value of pressure altitude to which they are applicable.

The error due to lag in static-pressure or pressure-altitude determination for a particular rate of descent may be determined in advance. The basic differential relation between pressure and altitude in the atmosphere $dp = -\rho g dh$ may be written by means of the gas laws in terms of rate of change as

$$\frac{1}{p} \frac{dp}{dt} = -\frac{1}{RT} \frac{dh}{dt} \quad (30)$$

In terms of sea-level temperature T_0 and any other temperature, equation (30) is equivalent to

$$\frac{1}{p} \frac{dp}{dt} = -\frac{1}{RT_0} \frac{T_0}{T} \frac{dh}{dt} = -3.616 \times 10^{-5} \frac{T_0}{T} \frac{dh}{dt} \quad (31)$$

Substituting values of λ and dp/dt from equations (24) and (31), respectively, in equation (29) gives

$$p' - p = 1.47 \times 10^{-2} \lambda_{p_0} \frac{\mu T_0}{\mu_0 T} \frac{dh}{dt} \quad (\text{in. H}_2\text{O}) \quad (32)$$

Since $\mu T_0/\mu_0 T$ in the standard atmosphere varies between 1.0 and 1.05, the error in static pressure at any altitude may be approximated by

$$p' - p \approx 0.015 \lambda_{p_0} \frac{dh}{dt} \quad (\text{in. H}_2\text{O}) \quad (33)$$

where dh/dt will have negative values during a dive.

Since the magnitude of dh/dt for a fighter airplane rarely exceeds 800 feet per second during a dive, equation (33) may be written as

$$\lambda_{p_0} \leq \frac{p' - p}{12}$$

This equation indicates a maximum value for λ_{p_0} of 0.04 if the error in static pressure is to be limited to 0.5 inch of water during very high speed dives.

For standard altimeters, the error in pressure altitude is

$$h_p' - h_p = -\lambda_{p_0} \frac{\lambda}{\lambda_0} \frac{dh_p}{dt} \quad (34)$$

Equation (34) indicates that for a constant rate of descent the error due to lag increases with altitude; for example, the value at 30,000 feet is 2.8 times as large as the sea-level value and at 60,000 feet is 11.1 times as large. (See fig. 9.)

Impact-pressure measurements.—In reference 40 approximate equations for the effect of lag on the readings of an air-speed indicator are developed. These equations show that the error is a resultant of two terms—a climb term, chiefly a function of changes of static pressure, and an acceleration term associated with changes in speed. Since precise evaluation of flight data involves the determination of the impact pressure q_c and the static pressure p and, from the ratio q_c/p , the Mach number, a more detailed analysis is needed to show under what conditions corrections to flight pressure data may be necessary on account of lag. This analysis also gives a basis for planning an instrument setup to minimize the errors due to lag.

Let p denote the static pressure at the static orifices, and let $II = p + q_c$ denote the total pressure. At the differential pressure recorder a record of q_c' is made for which

$$q_c' = II' - p' \quad (35)$$

At the same time, the altitude record of p' is made independently, usually on the same film strip or with an adjacent altimeter. Applying equation (15) to equation (35) gives

$$q_c' = II' - p - \lambda_H \frac{dII'}{dt} + \lambda_p \frac{dp'}{dt} \quad (35a)$$

No record of II' is made; but, since at any time,

$$II' = q_c' + p'$$

then

$$\frac{dII'}{dt} = \frac{dq_c'}{dt} + \frac{dp'}{dt}$$

and equation (35a) becomes

$$q_c' = II' - p + \lambda_p \frac{dp'}{dt} - \lambda_H \frac{dp'}{dt} - \lambda_H \frac{dq_c'}{dt} \quad (35b)$$

But $II' - p = q_c$, the true impact pressure, and except for corrections due to the flow about the static head which can be made independently, the usual assumption that $q_c' = q_c$ therefore involves an error due to lag

$$q_c' - q_c = \lambda_p \frac{dp'}{dt} - \lambda_H \frac{dp'}{dt} - \lambda_H \frac{dq_c'}{dt} \quad (36)$$

The pressure in the total-pressure line is greater than that in the static line by an amount equivalent to q_c or q_c' . The lag constant of the static-pressure system may be expressed as the following modification of equation (24):

$$\lambda_p = \lambda_{p_0} \frac{\mu p_0}{\mu_0 p} = \lambda_{p_0} \frac{\lambda}{\lambda_0}$$

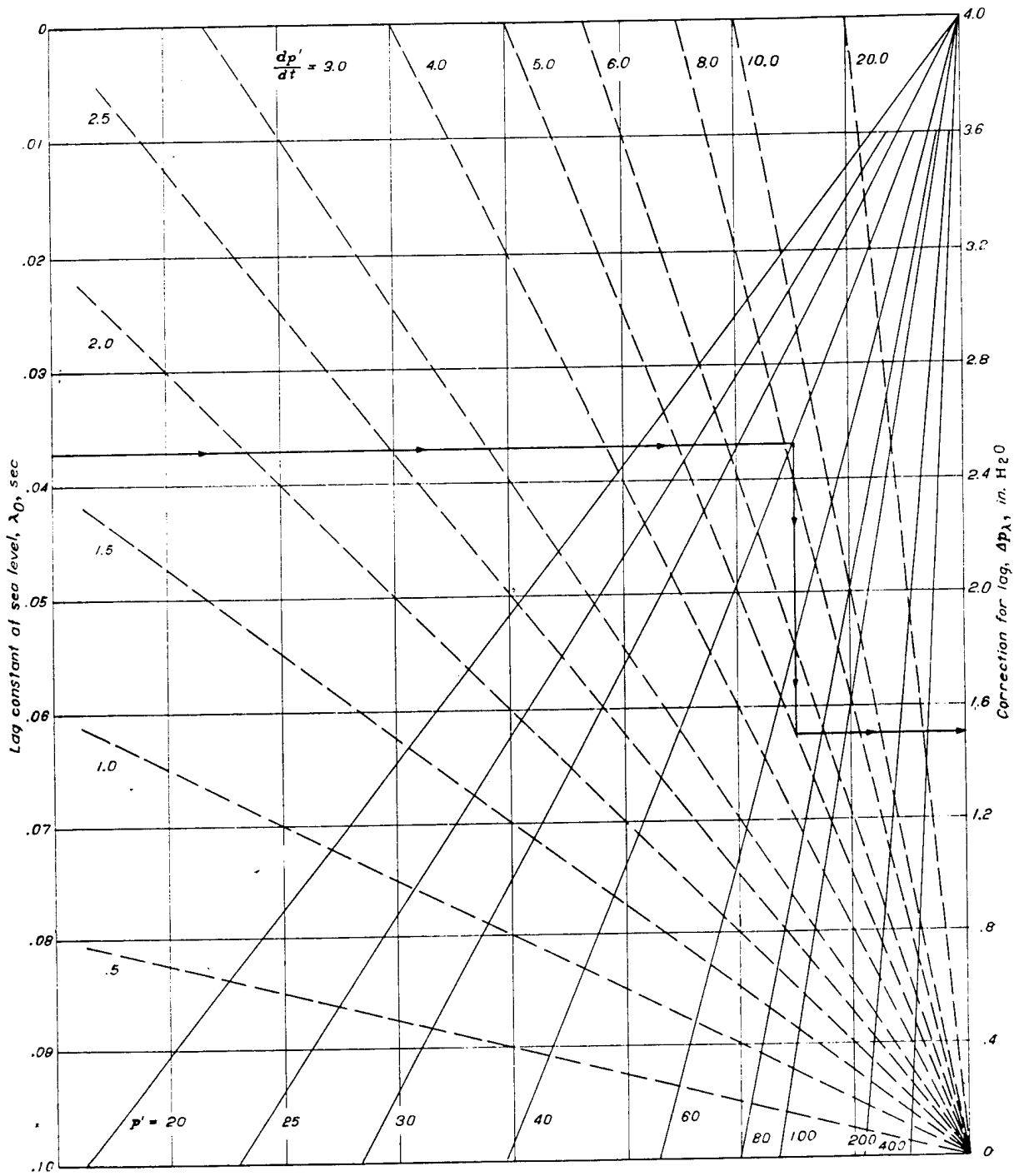

FIGURE 10.—Chart to correct measured pressures for lag. dp'/dt , inches H₂O per second; p', inches H₂O.

For the total-pressure system if second-order effects are disregarded, the corresponding expression is

$$\begin{aligned} \lambda_H &= \lambda_{H_0} \frac{\mu}{\mu_0} \frac{p_0}{H'} \\ &= \lambda_{H_0} \frac{\mu}{\mu_0} \frac{p_0}{\frac{q_c'}{\rho'} + \frac{p'}{\rho'}} \\ &= \lambda_{H_0} \frac{\lambda}{\lambda_0} \frac{1}{1 + \frac{q_c'}{p'}} \end{aligned} \quad (37)$$

The true impact pressure q_c may, therefore, be derived from flight records by the following relationship involving measurable quantities:

$$q_c = q_c' + \left[\frac{\lambda_{H_0}}{1 + \frac{q_c'}{p'}} \left(\frac{dp'}{dt} + \frac{dq_c'}{dt} \right) - \lambda_{p_0} \frac{dp'}{dt} \right] \frac{\lambda}{\lambda_0} \quad (38)$$

The variation of λ/λ_0 with pressure altitude in the standard atmosphere may be obtained from figure 9.

The rates of pressure change in equation (38) can be expressed in terms of M , dM/dt , h_p , and dh_p/dt . In the resulting expression the term containing dM/dt is multiplied by a factor $\frac{7\mu}{\mu_0(M^2+5)}$ which is approximately equal to 1 at high-speed and altitude, the condition under which lag is of most significance. Equation (38) may therefore be expressed as

$$q_c' - q_c \approx \left[\underbrace{-0.015 \left(1 - \frac{\lambda_{H_0}}{\lambda_{p_0}} \right) \frac{dh_p}{dt}}_{\text{Climb term}} - \underbrace{p_0 \frac{\lambda_{H_0}}{\lambda_{p_0}} M \frac{dM}{dt}}_{\text{Acceleration term}} \right] \lambda_{p_0} (\text{in. H}_2\text{O}) \quad (39)$$

Equation (39) can be used to find out in advance whether for any planned maneuver the error in q_c due to lag will exceed any specified standard of accuracy.

The ratio $\lambda_{H_0}/\lambda_{p_0}$ is significant in determining the relative magnitudes of climb and acceleration terms. Equation (39) shows that in rate-of-climb testing since dM/dt may be ignored, zero impact-pressure error due to lag may be achieved by balancing the lines, that is, by increasing λ_{H_0} until $\frac{\lambda_{H_0}}{\lambda_{p_0}} = 1$. During dive testing, however, balancing the lines can result in larger lag errors than those that were present before balancing. During a dive, $q_c' = \frac{q_c}{p}$ at the peak Mach number ($\frac{dM}{dt} = 0$) if $\frac{\lambda_{H_0}}{\lambda_{p_0}} = 1 + \frac{q_c}{p}$, a characteristic of the instrumentation which may be desirable under some conditions.

The Mach number error $M' - M$ which would result from the evaluation of q_c'/p' for any specified maneuver without correction for lag can be computed from equations (39), (33),

and (4). The error in M that would result from the use of such uncorrected data is shown in figure 11 as the time history of ΔM during a dive to a Mach number of 0.8, a dive that is representative of the performance of high-speed fighter airplanes. The error is shown for a static-pressure system with $\lambda_{p_0} = 0.1$ which is representative of panel-type instruments in airplanes of fighter size, and for four different values of $\lambda_{H_0}/\lambda_{p_0}$ which range from the limiting minimum of zero to a maximum of 1.5, the value for which the error in Mach number should be zero when $M = 0.8$ and $\frac{dM}{dt} = 0$. The time histories of ΔM for the dive and recovery show large changes in magnitude and also changes in sign. In general, if this dive had been performed at a different altitude, the error would have varied approximately inversely with the static pressure. For example, if the altitude had been about 65,000 feet, the errors would have been about seven times as great. The Mach number error is also directly proportional to λ_{p_0} , as is shown by the dotted-line curve for $\frac{\lambda_{H_0}}{\lambda_{p_0}} = 0.5$, $\lambda_{p_0} = 0.5$, the ordinates for which are approximately five times as great as for the solid-line curve for $\frac{\lambda_{H_0}}{\lambda_{p_0}} = 0.5$, $\lambda_{p_0} = 0.1$.

The lag errors shown in figure 11 for the condition for $\frac{\lambda_{H_0}}{\lambda_{p_0}} = 0.5$ could usually be ignored if $\lambda_{p_0} \leq 0.1$. For most practical installations, as shown by figure 8, the use of $\frac{3}{16}$ -inch inside-diameter tubing is required to obtain values of $\lambda_{p_0} \leq 0.1$. Higher speeds and altitudes, however, necessitate corrections or special care in keeping the lag constant small.

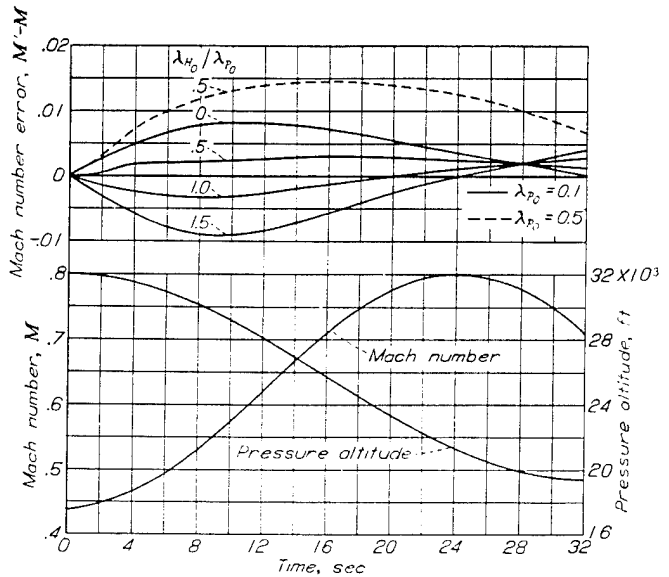

FIGURE 11.—Time history of Mach number error due to lag for representative values of lag constant during typical dive and recovery of a high-speed fighter airplane.

METHODS FOR REDUCING LAG

Since correction of flight data for lag effects may involve considerable labor, the lag constants of the total- and static-pressure systems should be reduced so that no corrections are necessary. In order to reduce the length of tubing it may be necessary to relocate instruments. Photo-observers or automatic-recording instruments may be located in a wing to eliminate a long line from a total- or static-pressure head. For research purposes separate installations for the pilot's indicating instruments and the instruments installed in a photo-observer are often desirable in order to reduce the volume of instruments attached to one line. Extra volume in instrument cases may be reduced with fillers.

For rate-of-climb or glide testing it may be desirable to make the lag constants of the total- and static-pressure systems equal. In practical applications it is usually necessary to increase the lag constant of the total-pressure system. Either length or volume may be added, but additional volume in the system does not increase the value of τ . A quick check for balance is to apply a pressure from a single source to both static- and total-pressure orifices. When this pressure is suddenly released, the differential-pressure indication is not steady if the lines are unbalanced. Little or no advantage is obtained by balancing the lines for high-speed dive tests.

The fact that the increased accuracy that corresponds to low values of λ may be offset by the presence of surges and transients in an underdamped system must be considered in the design of airspeed systems. Whether a particular installation is underdamped can be determined by a comparison of values of τ from figure 8 with values of λ obtained from the product $\lambda_0(\lambda/\lambda_0)$ from figures 8 and 9. The relation for critical damping $\lambda = \tau$ (reference 46) may be written by use of equations (13) and (22) as

$$L_{cr} = \frac{D^2 a}{32\nu} \left(\frac{1}{1 + \frac{v}{LA}} \right) \quad (40)$$

Systems with tubing shorter than that given by equation (40) are underdamped; those with longer tubing are over-damped. The length of tubing for critical damping decreases rapidly with an increase in altitude and is 54, 18, and 4 feet at sea level, 35,000 and 65,000 feet, respectively. These values apply to $\frac{3}{16}$ -inch inside-diameter tubing and are based on the assumption that v may be neglected in equation (40).

Because of the small values of L_{cr} at high altitudes, resonant effects are not a problem with the usual airspeed system. For flight at low altitudes, in gusts or turbulent air, and under landing conditions, critical damping or over-damping of both total-pressure and static-pressure systems may be desirable since the correction for lag is then not complicated by oscillations that are recorded but not present in the applied pressure.

CRITERION FOR AVOIDING LAG CORRECTIONS

A simple measure of the error in Mach number resulting from lag errors can be based on equations (33) and (39). Since the chief source of lag error in the value of q_c'/p' as determined from flight data is the climb term of equations (33) and (39) and since the number and volume of instruments on the static-pressure line are usually much greater than those on the total-pressure line, λ_{p_0} is much smaller than λ_{p_0} . A convenient approximation is, therefore,

$$\frac{q_c'}{p'} = \frac{q_c + 15 \times 10^{-3} \lambda_{p_0} \left(-\frac{dh}{dt} \right)}{p - 15 \times 10^{-3} \lambda_{p_0} \left(-\frac{dh}{dt} \right)} \quad (41)$$

The ratio of the climb term to the static pressure determines $M' - M$, the amount that the measured Mach number varies from the correct Mach number. If the rate of altitude change is expressed in terms of Mach number, speed of sound, and dive angle $\left(\frac{dh}{dt} = Ma \sin \theta \right)$, then from equation (6a) the following relation can be obtained:

$$\Delta M < 2.15 \times 10^{-3} \frac{a}{p} (M^2 + 5) \lambda_{p_0} \sin \theta$$

where a is in feet per second and p is in inches of water.

The error in Mach number depends only slightly on the absolute value of M . An average high-speed value of 0.8 may therefore be used. Since this expression for ΔM gives a maximum value for Mach number error and the effect of acceleration is to reduce the magnitude or to change the sign, the following expression may be written for the maximum error in Mach number due to lag during a dive:

$$\Delta M < \frac{12a \times 10^{-3}}{p} \lambda_{p_0} \sin \theta \quad (42)$$

Equation (42) is shown graphically in figure 12 for a range of pressure altitude from 0 to 60,000 feet and for four different values of dive angle.

A quick estimate of the need for lag corrections can be made as follows: Select from figure 8 a value of λ_0 applicable to the instrument installation. With this value of λ_0 and with maximum values for pressure altitude and dive angle, a value of Mach number error ΔM can be obtained from figure 12. If this value of ΔM is smaller than the desired precision for the contemplated flight-test program, corrections for lag may be omitted in the analysis of flight data. If the value of ΔM is too large and a more detailed analysis made by using equations (33) and (39) gives errors that are too large, the lag constants of the system can be reduced.

PRESSURE INSTRUMENTS

The instruments used in recording or indicating the pressures of a pitot-static arrangement are subject to a variety of

mechanical errors, many of which may be large in comparison with the precision of airspeed and Mach number measurement that is desirable in research. In this section, the sources and magnitudes of these errors are discussed together with methods for their reduction or elimination.

Since the operation of these instruments is based on the elastic properties of metal capsules, a main source of error is the property of elastic lag common to all stressed materials that makes the deflection for any pressure change depend on the magnitude, direction, and rate of the change, as well as upon the direction, magnitude, and rate of previous changes. All the effects of this property are defined in terms of the experiments by which they are measured and are usually known as hysteresis, after effect, recovery, and drift.

Hysteresis is the difference between the instrument readings for a given pressure cycle when a given pressure is reached by increasing the pressure and when that pressure is reached by decreasing it. Linkage friction present must be eliminated by vibration. The difference remaining immediately upon return to the initial pressure is called *after effect*. The after effect decreases with time; this change is called *recovery*. If an instrument is subjected to a change of pressure and the

new pressure is held constant, the reading of the instrument, in general, varies with time. This change in reading is called *drift*. The drift is positive if the reading continues to change in the same direction as during the pressure change. The *local sensitivity* of an instrument is the change in reading with respect to a change in pressure.

Temperature error is the change in the indication of the instrument due solely to a change in instrument temperature. In instruments not compensated for temperature, the error is only secondarily due to a change in size of the parts and is the result chiefly of change in the elastic modulus of the diaphragm material (reference 52). This error in indication is about 0.02 percent per °F for most metallic diaphragm materials. Temperature compensation is built into modern instruments, and the residual error varies for individual instruments.

Friction error is the change in indication when the instrument is tapped after a change of pressure in the absence of vibration. It is a measure of any binding or sticking of the instrument parts.

Acceleration error is the change in indication per g of acceleration. This error is usually greatest in a direction normal to the plane of the instrument diaphragm. A special case of acceleration error is sometimes called *position error*, the difference between the reading of the instrument when held in any one position and tapped and the reading at any other position. It is a measure of both play in the parts and static unbalance.

Vibration error, as considered in the present report, is the change in reading resulting from a shift in the midpoint of the indicator oscillation due to instrument-panel vibration. It is evidence of nonlinearity in a system.

Zero shift is the change in the zero point of the calibration due to the gradual release of fiber stress in the diaphragm material. In a well-made instrument, this effect is small and normally does not change the shape of the calibration curve. With instrument use there may also be zero shift due to wear of the component parts.

In instrument manuals the quantity called scale error usually refers to an over-all measure of both hysteresis and the adjustment of the linkage with which the proper relation between diaphragm deflection and pointer deflection is secured. By proper calibration the hysteresis and the correction for linkage adjustment can be determined. Scale error therefore is not considered in the aforementioned sense in the present report.

An instrument is said to be *rested* if it has, for all practical purposes, been subjected to no pressure change in the previous 24 or more hours. An instrument is put into the *cyclic state* (reference 55) by subjecting it to a number of cycles (about 5) of pressure change. The magnitude of the cycle defines the range of pressure for which the cyclic state exists. The effect of the cyclic state lasts about 1 hour.

Although all pressure instruments for aircraft are subject to these errors to some extent, the property of elastic lag is a more serious source of error in altimeters than in airspeed indicators because of the large mechanical multiplication in altimeters between capsule and pointer deflection.

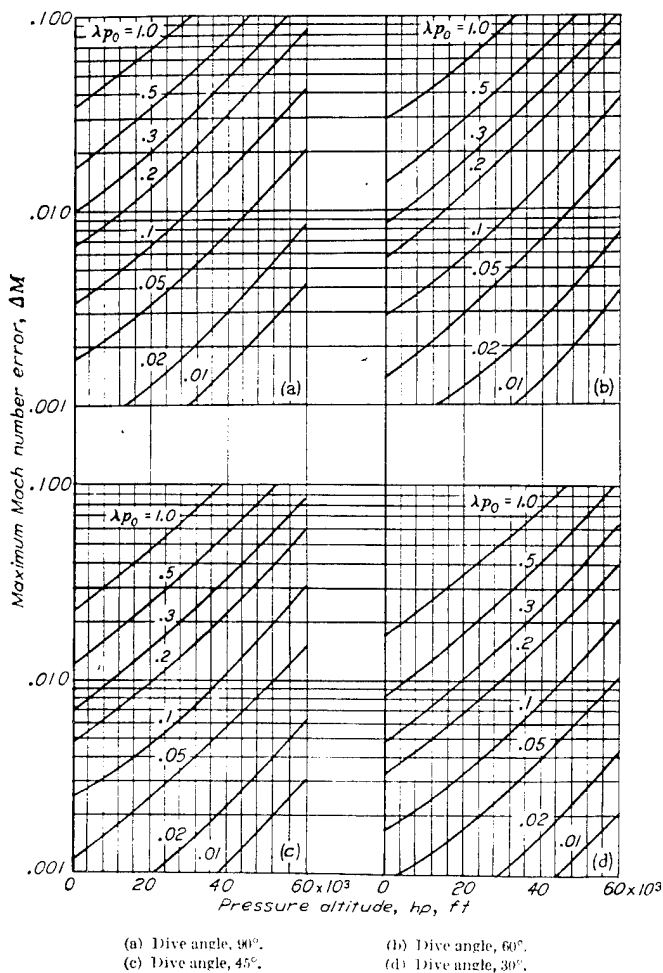

FIGURE 12.—Maximum Mach number error due to lag in dives.

THE AIRSPEED INDICATOR

In accordance with the formula by which airspeed indicators are calibrated (see references 10 and 51) a change in indication of 1 mile per hour corresponds to a change in impact pressure (sensitivity measured in inches of water) as given for various indicated airspeeds in the following table:

Indicated airspeed, mph	100	200	300	400	500	600	700
Δq , in. H ₂ O	0.10	0.21	0.32	0.45	0.60	0.79	1.03

The possible magnitude of errors that may be encountered in airspeed indicators in service together with methods for their elimination or reduction is given in table I, which is based on values from instrument handbooks and specifications. Although available commercial instruments are likely to be more accurate than the values in table I indicate, careful instrument selection and calibration at frequent intervals are necessary if a precision of ± 0.5 inch of water is to be achieved in the measurement of differential pressure.

TABLE I.—INSTRUMENT ERRORS—AIRSPEED INDICATORS

Type	Magnitude	Method of correction or elimination
Hysteresis	3 mph to 0.2 mph	Select instrument with low hysteresis.
Friction	± 3.5 mph	Provide sufficient instrument-panel vibration.
Position and acceleration	Up to 3 mph per g	Calibrate over range of indicated airspeed and g; mount so that axis of high sensitivity to acceleration is axis of small airplane acceleration.
Temperature	± 3.5 mph for 80° C (144° F) temperature change	Calibrate at temperatures of expected use or over range of temperature and interpolate.
Readability	± 0.5 mph	Check for excessive instrument-panel vibration; adjust exposure time of photo recorders to include at least one complete oscillation of needle.
Vibration	± 2.5 mph	

THE ALTIMETER

Aircraft altimeters are calibrated in accordance with the relation between pressure altitude and static pressure expressed in standard tables such as those in reference 4 or 10. Errors of ± 100 feet or ± 0.5 inch of water at different altitudes correspond to errors in pressure or altitude, respectively, as shown in the following table:

Pressure altitude, h, (ft)	$\frac{\Delta p}{p}$ for $\Delta h_p = \pm 100$ ft (percent)	$\frac{\Delta h_p}{h}$ for $\Delta p = \pm 0.5$ in. H ₂ O (ft)
0	± 0.36	± 31
5,000	$\pm .37$	± 39
10,000	$\pm .39$	± 46
20,000	$\pm .42$	± 64
30,000	$\pm .45$	± 91
40,000	$\pm .47$	± 140
50,000	$\pm .47$	± 220
60,000	$\pm .47$	± 300
70,000	$\pm .47$	± 580

The possible magnitude of errors that may be encountered in sensitive altimeters in service is given in table II (adapted from reference 52).

TABLE II.—INSTRUMENT ERRORS—SENSITIVE ALTIMETERS

Type	Magnitude	
	50,000-foot altimeters	35,000-foot altimeters
Hysteresis, ft		
For 32,000 ft pressure cycle at 1,000 ft/min		
At 20,000 ft	250	150
At 12,000 ft	200	100
For 300 ft deviations from sea level	30	50
Drift at 32,000 ft, ft		
In 30 sec	25	10
From 30 sec to 10 min	15	10
From 30 sec to 5 hr	40	40
After effect, ft	90	65
Recovery, ft		
During 30 sec	25	15
During 1 hr	40	25
During 5 days	55	40
During 21 days	75	55
Friction and vibration, ft	Up to ± 20	Up to ± 20
Zero shift, in 50 days, ft	-10	-10
Readability, ft	± 5	± 5
Acceleration, ft/g	Up to ± 10	Up to ± 10
Temperature		
At sea level, ft/°F	± 0.5	± 0.4
At an altitude above 5,000 ft, ft/ft °F	± 0.00015	± 0.00007

The elastic-lag errors in table II are based on unpublished results of tests at the National Bureau of Standards; in these tests pressure and deflection are measured without interrupting the change to make the measurement, thus conditions of actual use are more nearly realized. The hysteresis errors are about twice as large as expected on the basis of previous test methods. The values of hysteresis, drift, after effect, and recovery are based on the average of four rested altimeters of each of the two altitude ranges for a pressure cycle of 32,000 feet at 1000 feet per minute, with a drift period of approximately 5 hours at 32,000 feet. These values are given to show order of magnitude and should not be used as corrections since individual instruments may show irregular departures from the average of as much as 35 percent.

For precision airspeed measurements and especially in flight calibration of airspeed installations by fly-by methods, utmost care is both essential and justified in the preparation and use of altimeter calibrations.

Temperature error may be eliminated by selection of a temperature-compensated instrument with very small residual error. Except for elastic-lag effects, most of the errors can be readily allowed for or can be reduced by careful instrument adjustment and selection.

Since elastic-lag errors depend so greatly on previous instrument history, a calibration can be used with more confidence if there is a similarity between conditions of use and of calibration. If a rested instrument is used, successive hysteresis loops will not be identical, and calibrations can be obtained accordingly. Since the hysteresis, drift, after effect, and recovery, in general, increase with the range of pressure change, the range of the calibration can be adjusted to the maximum pressure altitude of any planned flight or series of flights. If small changes in altitude indication are important, as in runs past a reference landmark, a special calibration should be made since for small changes in pressure individual altimeters often exhibit marked variations in local sensitivity. If the altimeter is in the cyclic state both

for calibration and flight test, hysteresis can be reduced about 50 percent and after effect, about 75 percent. (See reference 55.)

For some purposes measurements of pressure altitude must be converted to true altitude. True altitude can be derived from pressure altitude if corrections are made for ground temperature, departure from the constant lapse rate, moisture content of the air, and the mean local value of gravity. Methods of making these corrections are outlined in reference 55.

NACA INSTRUMENTS

The pressure-recording instruments used at the laboratories of the NACA are much like those shown in figure 23 of reference 51, except that a corrugated metal capsule has been substituted for the stretched diaphragm. The capsule deflection is multiplied by a stylus-hairspring-mirror arrangement and readings are made of the record of a light trace on a moving photographic film. A wide range of sensitivities is available, so that the instrument range can be adapted to the maximum pressure to be measured. Multiple-mirror instruments are available to expand the scale. The pressures in two or more cells may be recorded on the same film. A reference line is recorded on the film by means of an auxiliary fixed mirror which eliminates shifts in the film drum as a source of error. Several instruments are correlated by means of a time signal recorded on each film. The natural frequency of the mechanical parts is 100 cycles per second or more so that inertia effects may be ignored. Hysteresis is made small by selection of capsules with favorable elastic-lag properties. Temperature-compensated instruments are available. By individual calibration of each capsule in an airspeed installation, errors from hysteresis, temperature, and acceleration effects may be either made negligible or allowed for in evaluating data.

TEMPERATURE MEASUREMENTS

Temperature measurements are essential in the conversion of pitot-static pressure data to true airspeed. Since instruments which measure directly the true free-air temperature in flight are not available, this quantity must be computed. The accuracy of the result is governed by the accuracy with which the recovery factor of the temperature probe is known, the accuracy of the Mach number, and the calibration of the indicating or recording instrument. In this section the sources and magnitudes of errors and the evaluation of temperature data are discussed.

SOURCES OF ERROR

Important sources of error in free-air temperature measurement are:

(a) Variation in the recovery factor of the temperature probe due to the incomplete conversion of kinetic energy into thermal effects as affected by

- (1) Probe design
- (2) Local velocity
- (3) Local angle of flow
- (4) Free-stream velocity

(b) Errors due to lag

(c) Errors of the measuring apparatus caused by

- (1) Temperature effects on springs, resistances, bearings, and magnets
- (2) Acceleration error, zero shift, vibration error, friction error, and hysteresis
- (3) Electrical effects such as changes in voltage, contact or lead resistance, and local magnetic field

(d) Radiation to or from surroundings or sun

(e) Conduction to or from surroundings

Other errors such as those due to heating caused by electric-current flow, probe contamination, and so forth are generally small and may be neglected.

Velocity effects.—Sources of error due to velocity effects may be the largest and most difficult to remove by calibration. As shown by a number of investigators, the temperature T' indicated by a thermometer in a gas stream of relative velocity V is larger than the true free-stream temperature T . For a thermometer that brings the air to rest at a stagnation point without heat transfer the indicated temperature is the total temperature of the gas T_T and the thermometer registers the full adiabatic rise:

$$T_T - T = \frac{\gamma - 1}{2\gamma Rg} V^2 = \frac{\gamma - 1}{2} TM^2 = 0.2 TM^2 \quad (43)$$

Equation (43) is not limited to $M \leq 1.0$ but is applicable to supersonic flight speeds.

Thermometer probes of the stagnation type have been developed that register the full adiabatic rise, or very nearly all of it (references 65 and 80). Many of the thermometers in use on aircraft, however, are not of the stagnation type. On the basis of theoretical considerations references 62 and 71 show that for laminar flow over a thin plate parallel to the air stream, in which case the air is brought to rest by friction at the plate surface, the temperature rise is, to a close approximation,

$$T_T - T = \frac{\gamma - 1}{2\gamma Rg} V^2 (Pr)^{1/2} \quad (44)$$

The Prandtl number Pr has a theoretical value of $\frac{4\gamma}{9\gamma - 5}$. For air under standard conditions ($\gamma = 1.4$), $Pr = 0.737$ and equation (44) can be written

$$T_T - T = 0.858 \frac{\gamma - 1}{2\gamma Rg} V^2 = 0.858 (0.2 TM^2) \quad (45)$$

Within the limits of experimental error, equation (45) is confirmed by wind-tunnel tests (references 69 and 80) as applicable to an object of small diameter such as a thermometer bulb parallel to the air stream under conditions of a laminar boundary layer. When temperature is measured in flight, however, the numerical factor in equation (45) may be subject to considerable variation. In order to have a convenient basis for comparison, a temperature recovery factor K based on equations (43) and (44) has been defined as

$$K = \frac{T' - T}{T_T - T} \quad (46)$$

The temperature recovery factor is a measure of the ability of a particular probe, under particular conditions of flow, to develop the total temperature of the gas stream. Values of K between 1.0 and 0.3 have been reported for different probes, high values applying to those of the stagnation type. Reported values frequently show a variation with velocity, and wind-tunnel values may differ from values determined in flight. The reason undoubtedly lies in one or several of the factors in the following discussion.

For probes of the plate type, the theoretical value of $K = (Pr)^{1/2}$, which should be nearly independent of speed and atmospheric conditions, is only applicable to conditions of laminar flow. The results of theoretical calculations (reference 70) show that for turbulent flow, $Re > 5 \times 10^5$, K increases with Re and is between $(Pr)^{1/2}$ and 1.0. (This result is applicable to the temperature of a wing or fuselage in flight, as is shown in reference 66.) When K is a function of Re , it will vary with both speed and altitude. For cylindrically shaped probes mounted transversely to the air stream (references 63 and 70), there are large variations of local velocity over the probe, and K varies between 0.56 and 0.83. The minimum value occurs when a local Mach number of 1 is reached at the cylinder surface (about $M = 0.5$) and is due to the effect of shock. Because the variation in K is large, transverse mounting of temperature probes is not suitable for high-speed flight. In supersonic flow, plate-type probes would be in a region influenced by shock, and the value of K would be expected to differ from that at low speeds. Local variations of the velocity field about an airplane may be quite large and can cause an apparent variation in the value of K , since local temperature changes in this field take place with full adiabatic efficiency but the change from kinetic to thermal energy at the probe does not. Apparent variations may also be caused by radiation effects, local sources of heat, and changes in airplane configuration.

Probes of the stagnation type, with housings shaped like conventional total-pressure heads, show a variation of K with angle of flow and ratio i/D similar to the variation of total-pressure defect with angle of flow. (See fig. 2 (a).) Such probes are, however, little subject to apparent changes in the value of K due to local variations in the velocity field. Radiation and conduction errors may be made smaller and, since these probes measure total temperature, the measurement is not affected by shock.

Lag errors.—Temperature measurements in flight under conditions of changing temperature indication, as in a dive or sudden change of speed, are in error by an amount determined by the lag constant of the thermometer. The lag constant may be defined as the time for a suddenly applied temperature difference to fall to 36.8 percent ($1/e$) of its initial value. Because most thermometers are of composite construction and some parts take longer to reach their final temperature than others, a value of 1 percent of the initial value is sometimes given, but 36.8 percent is used in the present paper because of its correspondence with the value used for pressure lag in the section entitled "Determination of Lag Constant by Experimental Methods."

Theoretically, temperature data may be corrected for lag

on the basis of a relation analogous to equation (15). (See reference 42.) In practice, except for small thermocouples under carefully controlled conditions, the correction is complicated not only by the correction for speed (equations (43), (44), and (45)) but also by uncertainty in the value of λ which is a function of V . As shown in references 59, 61, and 68, λ may be considered to vary directly as the effective volume, density, and specific heat of the thermometer materials and inversely as the exposed area and surface heat-transfer coefficient h between the gas and the probe. As shown in reference 74, for turbulent flow of air transverse to a metal cylinder, an average value for h can be written in the notation of the present report as

$$\frac{hD}{k} = 0.26 (Re)^{0.6} (Pr)^{0.3}$$

A similar relation applies for flow parallel to streamline shapes. Over a wide range of Re the exponent 0.6 can be expected to vary; thus, to a first approximation for a limited range of temperature

$$\lambda = \frac{L}{(\rho V)^n} \quad (47)$$

where L is a constant for the particular probe concerned and n has a value between 0.35 and 0.85, this value averaging about 0.6 for a range of Re from 1,000 to 50,000.

Thermometers of the plate type will usually have lower values of λ than the stagnation type and are therefore commonly used in applications where low lag is important. The common metal-to-metal contact between the probe and the metal parts of the airplane should be eliminated. An idea of the order of magnitude of the errors in temperature measurement due to lag may be gained from unpublished tests at the Langley Laboratory; these tests indicate that for a resistance-type cylindrical probe, of a sort commonly used on airplanes, mounted transversely to the air flow the value of λ is 13 seconds at 350 miles per hour at sea level. Such a probe would be useful therefore only for determining temperatures under steady conditions.

Other errors.—Failure to provide adequate radiation shielding can cause a thermometer to read as much as 6° F. to 8° F. too high. (See reference 75.) The shield should be of highly polished metal, unpainted, insulated from the bulb, and may well be incorporated in a ventilated housing for the conventional resistance bulb or other temperature sensitive element. Radiation shielding is of less importance when an underwing mounting is used since sunlight strikes the bulb only when the sun is near the horizon. The effect of solar radiation may vary for flight into and away from the sun and with the intensity of the radiation. The effect is smaller at high speeds or high atmospheric densities.

Fluctuations in the free-air temperature are frequently large at any one altitude below 20,000 feet, although their existence may be masked by the lag of instrument installations. At 5,000 feet, variations of 5° F. have been observed in one locality, the variations dropping at 10,000 feet to 2° F. These variations can be a source of error in calibration and in temperature data drawn from temperature-altitude surveys.

In electrical methods a milliammeter is used to measure the degree of unbalance in the bridge circuit. The possible existence of errors in this measurement due to changing voltage supply, cockpit temperature, or acceleration should be checked by calibration since the rated scale error of even a well-designed instrument may be as much as ± 2 percent of the midscale absolute temperature.

LOCATION OF TEMPERATURE PROBE

Most of the considerations governing the proper location of the total-pressure head also apply to the temperature element. If a probe of unit recovery factor is available, an underwing position free from the effects of slipstream, engine exhaust, and de-icer heating is satisfactory. If the recovery factor of the probe is less than unity, departures of the local velocity from the free-stream value should be reduced by mounting the probe well in front of the leading edge of the wing. If direct indication, as with a bimetallic probe, is needed, the front tip of the nose of two- and four-engine airplanes is usually a satisfactory location.

Whatever the location selected for the thermometer probe, more accurate values of free-air temperature can be obtained if a value of recovery factor K is used which has been previously obtained by a flight calibration under conditions of use, as outlined in the section entitled "Temperature Installation."

EVALUATION OF FREE-AIR TEMPERATURE

If the recovery factor is known, the true free-air temperature may conveniently be determined from flight measurements of Mach number and indicated temperature by means of the chart (fig. 13) that is a graphical solution of equation (46). If true airspeed is required, the indicated temperature and Mach number may be used directly in the equation:

$$V = \frac{M\sqrt{\gamma RgT'}}{\sqrt{1+0.2KM^2}} \quad (48)$$

for which the solution is given in figure 14.

FLIGHT CALIBRATION OF AIRSPEED AND TEMPERATURE INSTALLATIONS

In the previous sections, material has been given concerning the errors which may be present in the determination of airspeed by pitot-static arrangements. Some of the sources of error encountered are inherent in the instruments and may be eliminated or allowed for by instrument selection and calibration. Although the errors caused by lag cannot be entirely removed by these means, a method has been given for making corrections when such corrections are necessary. There remain, however, possible errors in both the total and static pressures due to the location of the pitot-static device in the field of flow. These errors can best be determined by flight tests. Since the field of flow about an airplane varies with angle of attack and Mach number, the errors in both total pressure and static pressure

vary with the magnitude of these quantities. Similar conditions apply to the determination of true temperature from the value of the temperature recovery factor and Mach number.

AIRSPEED INSTALLATION

Methods used to calibrate airspeed installations may be divided into groups which may be loosely termed:

(a) The speed-course method in which time to cover a given distance is measured

(b) The suspended-head method in which readings of the airspeed system under calibration are referred to those of a suspended static or pitot-static head which is either free from error or has known errors

(c) The pacing method in which the airplane with the installation to be calibrated is flown in formation with one which has an airspeed installation already calibrated by method (a), (b), or (d)

(d) The altimeter method in which errors are determined from the difference between recorded and known pressure heights

Some advantages and disadvantages of each of these methods have been discussed and the methods described in detail in reference 92. The speed-course method is simple when used near the ground but is hazardous under these conditions, particularly at speeds near the stall. The range of calibration is limited by the top speed in level flight. Attempts to reduce the hazard of the speed-course method by testing at higher altitudes generally necessitate the use of elaborate timing and tracking methods. Corrections for wind and deviations in course are necessary and the airspeed obtained is, at best, only an average value.

The suspended-head method (references 85 and 96) is more accurate than the speed-course method and is especially applicable to stall testing. It is the preferred method for low and medium speeds but the obtainable range is limited by instability of the trailing head. For the NACA trailing airspeed head this limit is about 275 miles per hour. Because of pressure lag in the long connecting tubing the method is not suitable for maneuvers. For single-seat airplanes an automatic reel that simplifies the handling problem is available. This method may be used to obtain a direct measurement of the errors at the total- and static-pressure openings. Instruments of high sensitivity may be used for this measurement; thus, results of high precision are given. The induced velocity in the field beneath and behind the airplane must be allowed for when a suspended total-pressure head is used. Tests should be performed in stable, smooth air to avoid errors caused by turbulence and wind gradients.

The pacing method is relatively simple and removes the hazard of low-level flying. The calibration is less accurate, however, than the calibration of the reference airplane; the speed range is limited by the speed range of the reference airplane; and the practical difficulties increase when attempts are made to increase the speed range of the calibration by performing dives.

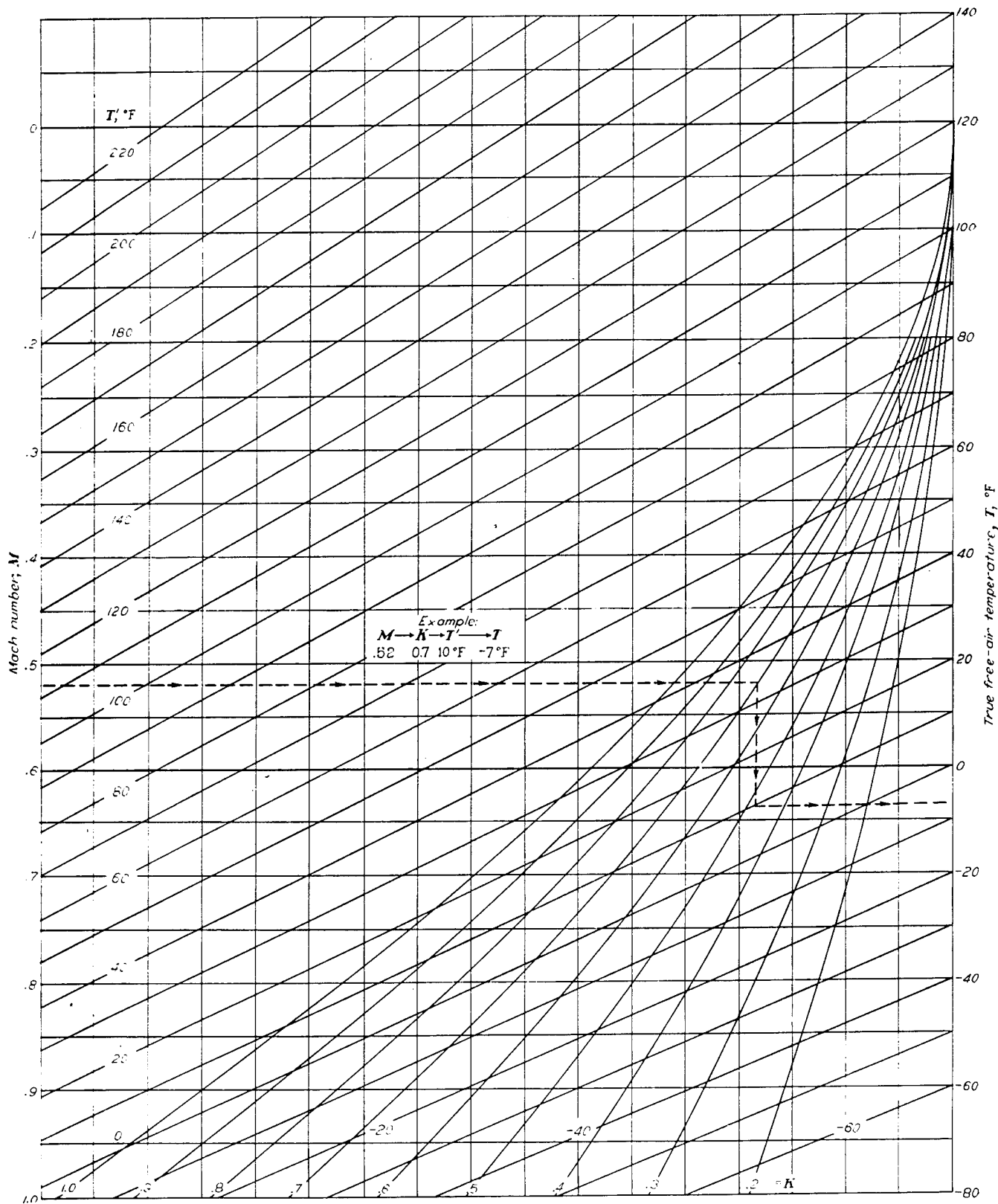

FIGURE 13.—True free air temperature as a function of Mach number, recovery factor, and indicated temperature.

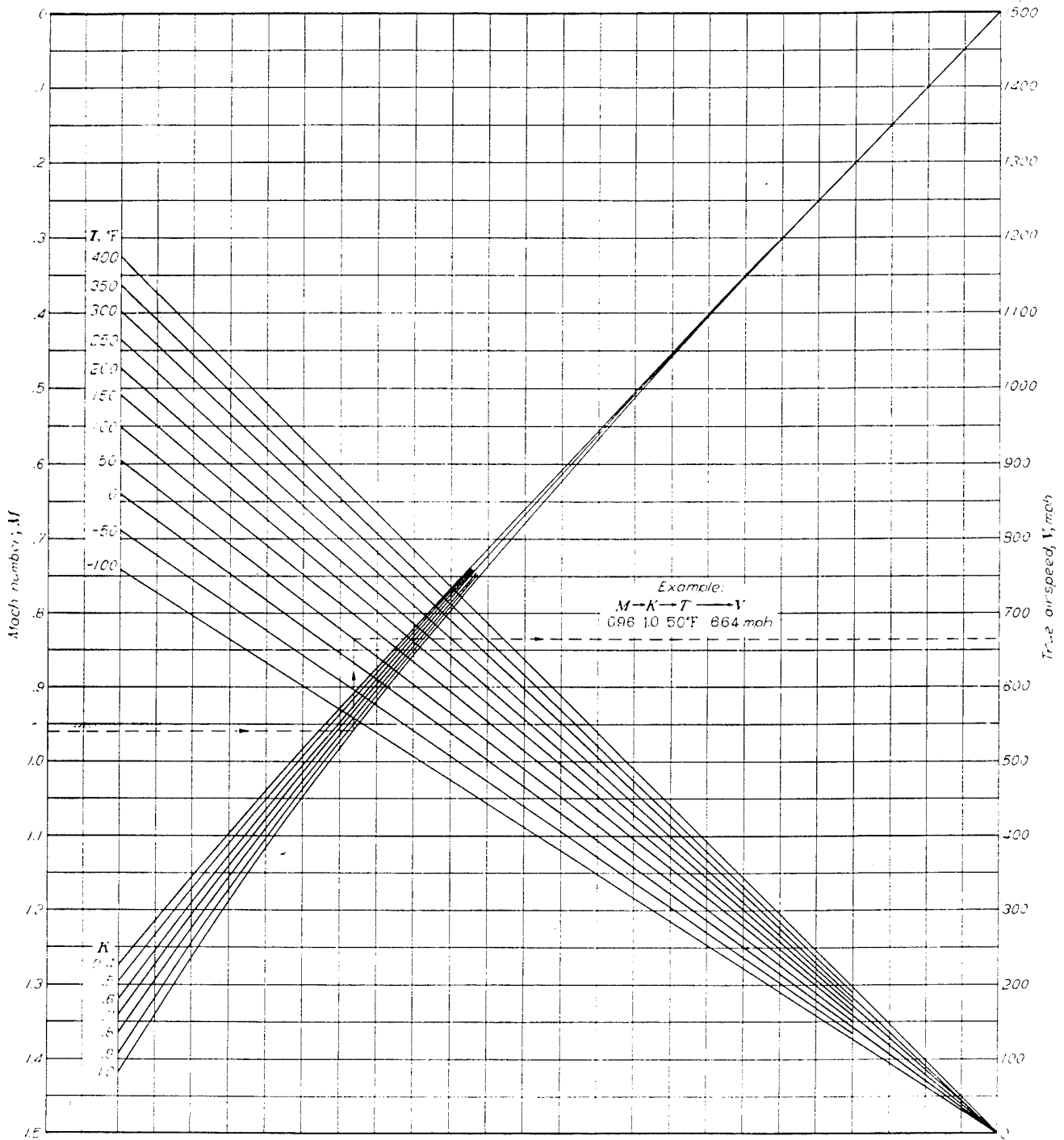

FIGURE 14.—True airspeed as a function of Mach number, recovery factor, and indicated temperature.

Because of the wide applicability of the altimeter method, especially at high speeds, the remainder of this section will be confined to a description of this method, and its variations, for the determination of errors in the total and static pressures. The altimeter method may conveniently be subdivided into four principal variations:

(1) Fly by a reference landmark. This variation is inherently simplest and most accurate, requiring measurement of the fewest quantities, but is limited to the speeds of level flight.

(2) Fly by a reference airplane. The possible hazard of flight near the ground is eliminated, and the calibration can be made at higher values of Mach number.

(3) Dive by a reference airplane. Calibration at speeds up to the terminal velocity of the airplane is possible, but elaborate instrumentation is required.

(4) Establish reference altitude by radar. Calibration is possible at values up to the terminal velocity and at lift coefficients associated with high accelerations.

Each of variations (2), (3), and (4) is dependent on the existence and precision of a basic calibration secured by flight past a reference landmark (variation (1)) or by some other method. At the Langley Laboratory variation (1) is used, supplemented, when necessary, by a combination of radar and phototheodolite (variation (4)).

Since errors in total and static pressures vary with the field of flow, for a given installation—that is, airfoil section, type of head, and location of head—the error would be expected to vary with Mach number and lift coefficient or angle of attack. A complete flight calibration for experimental purposes therefore involves determination of the errors throughout the maneuver envelope. A more limited but frequently adequate calibration consists only of calibrating in steady flight at 1 *g*. Position of flaps, landing gear, and movable armament, the power-on and power-off conditions can each make enough change in the lift characteristics of the wing to necessitate special calibration under some conditions.

Since the purpose of an airspeed calibration is to provide a means of correcting data obtained in flight, it is desirable to determine the pressure errors in a ratio form to be used in the following equations:

$$q_c = q_c' \left(1 - \frac{\Delta H}{q_c'} + \frac{\Delta p}{q_c'} \right) \quad (49)$$

$\underbrace{q_c}_{\substack{\text{True} \\ \text{impact} \\ \text{pressure}}}$	$=$	$\underbrace{q_c'}_{\substack{\text{Measured} \\ \text{impact} \\ \text{pressure}}}$	$\left(1 - \right.$	$\underbrace{\frac{\Delta H}{q_c'}}_{\substack{\text{Total} \\ \text{pressure} \\ \text{defect}}}$	$+ \left. \frac{\Delta p}{q_c'} \right)$	(49)
---	-----	--	----------------------	--	--	--------

$$p = p' - \left(\frac{\Delta p}{q_c'} \right) q_c' \quad (50)$$

$\underbrace{p}_{\substack{\text{True} \\ \text{static} \\ \text{pressure}}}$	$=$	$\underbrace{p'}_{\substack{\text{Measured} \\ \text{static} \\ \text{pressure}}}$	$-$	$\left(\frac{\Delta p}{q_c'} \right)$	q_c'	(50)
---	-----	--	-----	--	--------	--------

Measured values of total-pressure error ΔH and static-pressure error Δp are correlated by plots of total-pressure defect $\Delta H/q_c'$ and static-pressure defect $\Delta p/q_c'$ as functions of airplane lift coefficient C_L with uncorrected Mach number as a parameter. The correct values of Mach number, true airspeed, and dynamic pressure may then be determined by inserting the values of q_c and p as obtained from equations (49) and (50), respectively, into appropriate equations such as equations (2), (4), and (5), or by using the convenient tables and graphs given in reference 10.

Total-pressure error.—The total-pressure error, in general, is small and may usually be neglected. The necessity for a calibration of this error can usually be determined from a visual inspection of the pitot tube to determine: (a) the ratio of impact orifice diameter i to tube diameter D , (b) the possible angle of flow relative to the tube, and (c) whether the tube is located in a region where energy changes are introduced by shock or the slipstream. When, on the basis of equation (10) and figure 2, a calibration is deemed necessary, it is most conveniently performed by balancing the tube under calibration against one which has negligible error and by measuring the pressure difference. A tube with negligible error is one such as is described in reference 19 mounted on a boom at least $\frac{1}{8}$ chord in front of the airfoil and parallel to the airfoil chord. In the absence of a shielded total-pressure head, a tube with a large ratio i/D or a conventional pitot-static tube on a free-swivel mount such that the tube faces the relative wind may also be used, but stability at high speeds is difficult to achieve with this latter arrangement.

The instrumentation required in determining total-pressure error is relatively simple as it involves only the measurement of acceleration, altitude, and impact pressure in addition to the total-pressure difference. The flights required consist of a series of steady turns or slow pull-ups at various speeds in order to cover as wide a range of lift coefficient as possible.

Static-pressure error.—The principal error in most pitot-static installations is due to pressure defect at the static openings. An accurate static-pressure system depends, therefore, on a static-pressure head which does not introduce serious or indeterminate errors over the range of Mach number for which flight is contemplated. Since the geometry of the head influences to so great an extent the magnitude of the static-pressure defect, this information should always be determined for a new design by wind-tunnel tests, and the heads should be so installed that unnecessary changes in the calibration are not introduced by mounting studs, screws, and so forth.

The altimeter method of determining static-pressure defect is fundamentally a method in which the defect is determined from the difference in static pressure measured at the static orifices and the known pressure at a point of reference outside the pressure field of the airplane, which reference point the airplane either flies by or dives by.

The essentials of the altimeter method are illustrated in figure 15. A point of reference is established by an airplane of either known or unknown airspeed calibration that is flying at a slow constant indicated airspeed V_{i_1} and at constant value of indicated pressure altitude p'_{r_1} . In general this reference airplane has a static-pressure defect at the static orifices, so that although the instruments show a pressure altitude h'_{p_r} corresponding to the static pressure p'_{r_1} , the airplane is flying at a true pressure altitude h_{p_r} corresponding to $p'_{r_1} - \Delta p_r$. The airplane to be calibrated is first flown in formation with the reference airplane and the readings on both altimeters as well as the distance of the airplane above or below the reference airplane are noted. After this initial run the airplane is flown past the reference airplane at increasingly higher speeds (V_2, V_3, \dots, V_n) and instantaneous notations or recordings are made in both airplanes of pressure altitude, observed relative heights, differential pressure q_c (indicated airspeed), and acceleration n . The altitude differences obtained $(h'_{p_r} - h'_{p_r})_d$ and $(h - h_r)_{obs}$ are converted to pressure errors Δp_d and Δp_{obs} by means of the equation

$$\Delta p = -\rho g \Delta h \quad (51)$$

For altitude differences obtained from altimeters, ρ is the density of the standard atmosphere at the indicated pressure altitude; whereas for observed altitude differences, ρ is the density applicable to the pressure and temperature conditions of the test. The value of ρ may be approximate. When the pressure error of the reference airplane Δp_r is known from a prior calibration, the required static-pressure error Δp may be obtained directly from the equation

$$\Delta p = \Delta p_r + \Delta p_d - \Delta p_{obs} \quad (52)$$

where the signs are consistent with the definition of error used in the present report, as shown in figure 15.

If Δp_r , the error in the reference pressure, is not known by prior calibration, it may be determined from at least one known point on the calibration curve of the airplane being calibrated; such a point can be established by flying past a landmark such as a tower of known pressure height. Accuracy is improved if several runs past the landmark are made at the same or at different speeds through the range. Alternatively, if it is not desirable or possible to fly the airplane being calibrated past the landmark, the reference airplane may be flown past at the same indicated speed V_{i_1} that was used in the calibration and Δp_r determined from the difference between indicated and true pressure height. Accuracy is sacrificed when this latter means is adopted.

In figure 15 and equation (52) when the fly-by reference altitude is established relative to a fixed landmark, or what is essentially equivalent, by some triangulation method as with the dual sighting stand (reference 92), the pressure

altitude of the reference may be considered as known and the value of Δp_r is zero. If a captive balloon of known pressure height were used, Δp_r would also be zero.

Since the value of $\Delta p/q_c$ established by the altimeter method is dependent on the precision with which pressure or altitude differences are observed, the following equation may be derived from equation (51) and the definition of q_c :

$$\Delta h = -\frac{\Delta p}{q_c} \frac{V^2}{2g} = -\frac{\Delta p}{q_c} \frac{M^2 a^2}{2g}$$

In order to establish a value of $\Delta p/q_c$ (or $\Delta p/q_c$) with a precision of ± 0.01 , therefore, the altitude difference Δh at Mach numbers of 0.1, 0.3, 0.7, and 1.0 must be established to ± 2 , ± 20 , ± 100 , and ± 200 feet, respectively, at sea level. These values would be decreased by 25 percent at altitudes above 35,000 feet. Since the altimeter method is limited in the lower speed range, at the Langley Laboratory better results have been secured when photo-observers were used to record altimeter readings and the relative height of airplane and reference landmark.

The procedure outlined in connection with figure 15 is particularly adapted to tests in which calibrations are required only in the lift-coefficient range associated with flight near 1 g . When calibrations outside this range of lift coefficient at high Mach number are deemed necessary, the Langley Laboratory has used a combination radar-photo-theodolite method to establish the pressure height variation during calibration maneuvers. In this method, records are taken on the ground of the range measured by the radar unit and the elevation angle of the airplane measured by the phototheodolite in order to determine the geometric height during a constant-speed climb or glide over a range of altitude. Simultaneous values of pressure altitude, acceleration, and indicated airspeed are obtained in the airplane, correlation being secured by means of a radio signal. From these data a curve of the variation of airplane pressure height with radar height is established for the particular indicated airspeed of the climb. After the constant-speed climb or glide, dives, pull-ups, turns, or pull-outs are performed to cover as much of the maneuver envelope as may be required. During the maneuvers, simultaneous records are made at the ground and in the airplane, and the records are correlated by means of the timing impulses transmitted from the airplane.

The pressure difference (Δp_d of fig. 15) is determined from the difference between the pressure altitude recorded during the maneuver and the pressure altitude which was recorded in the climb for the particular height indicated by the ground station. The pressure difference at the reference speed of climb Δp_r is determined by a subsequent fly-by test or other tests considered adequate. The radar is thus used to establish the reference height rather than true airspeed so that wind velocities need not be taken into account. An example of the use of radar in establishing a reference height is given in reference 94.

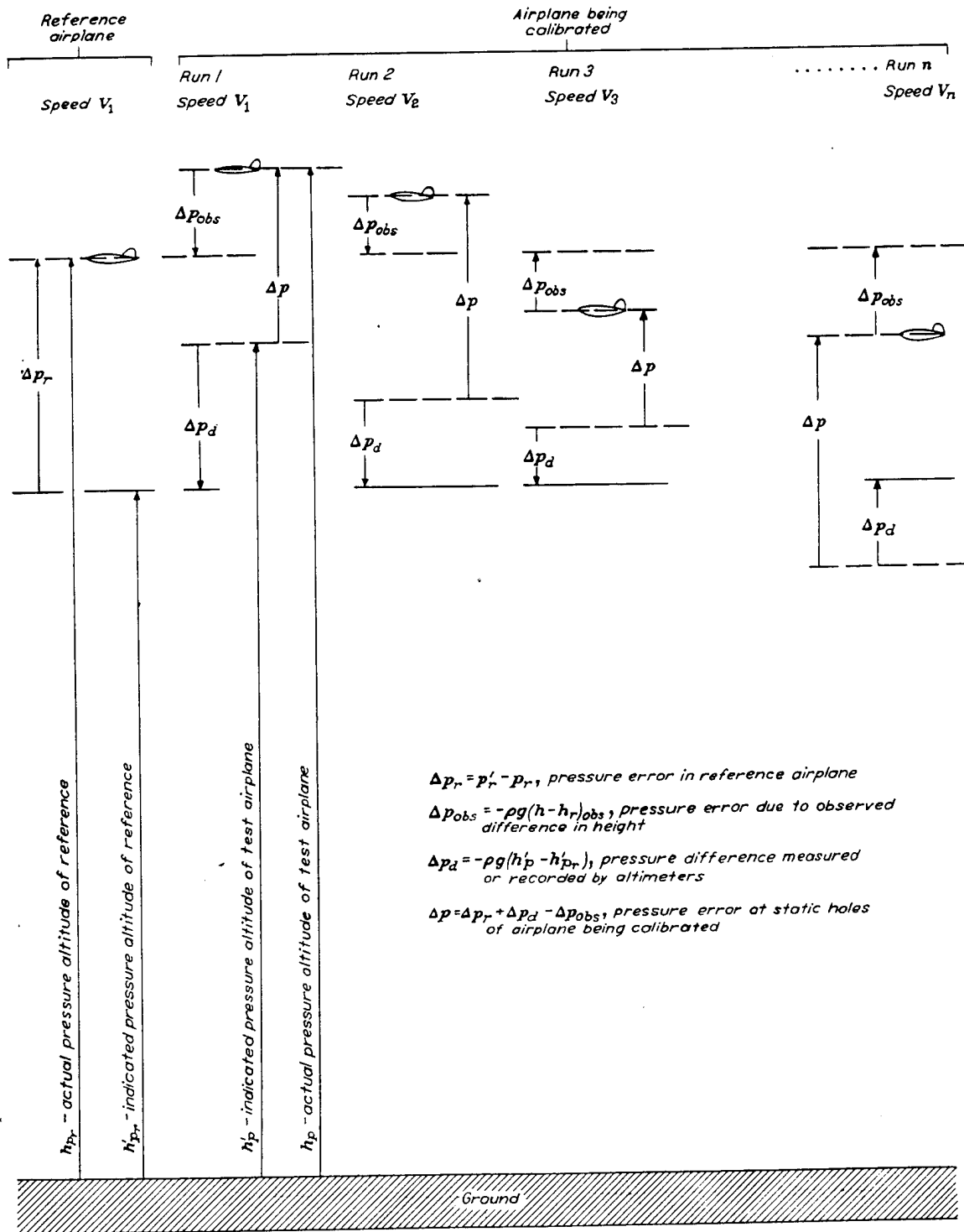

FIGURE 15.—Diagrammatic sketch showing essentials for determining static-pressure error by altimeter method.

The accuracy obtainable with the particular modification described is at present better than that obtained in flying by a reference airplane and about as good as that obtained in flying past a reference landmark. In order to obtain this accuracy, however, corrections for pressure lag, acceleration effects on instruments, the curvature of the earth, and refraction effects in the optical path are sometimes necessary in establishing geometric height. Care must be taken to have the radar scales horizontal. With corrections taken into account, the slant range is known to within ± 15 yards and the elevation angle to about $\frac{1}{2}$ mil. At a range of 10,000 yards, the total error in height is limited to approximately ± 20 feet, which is equivalent to a pressure error of about 0.2 inch of water at an altitude of 10,000 feet.

TEMPERATURE INSTALLATION

The calibration of a temperature installation consists, essentially, of the determination of a temperature-recovery factor K as defined by equation (46). If the error in true airspeed determination due to temperature error is to be less than $\pm \frac{1}{4}$ percent, the temperature measurement must be within $\pm 2^\circ$ F or about $\frac{1}{2}$ percent of its absolute value. (See equation (8).) This specification requires that for high speeds the recovery factor K and its variations with Mach number and lift coefficient be established to an accuracy better than ± 5 percent.

The flight procedure for calibrating a temperature installation is similar to that for calibrating an airspeed installation by the altimeter method; in fact, the calibrations may be made at the same time. An adequate procedure in most cases consists of flying the airplane being calibrated past a landmark at a series of speeds and either noting or recording the temperatures at the instant of passing the reference point. In the first series of tests the fly-by's should be made at the same heading (preferably away from the sun) and in as small an elapsed time as possible. Some fly-by runs should be made, if possible, on a heading such as to obtain the maximum effects of solar radiation. Knowledge of radiation effects may be required subsequently in evaluating data.

The true temperature at the landmark is obtained from a calibrated temperature installation shielded from solar radiation, such as the standard weather shelter (Stevenson screen). Small corrections are made to this temperature in order to account for any differences in height between the landmark and the airplane as it flies by. If a calibrated temperature installation is not available, T may often be determined by a plot of T' against M^2 . Equation (46) shows that for constant values of K and T such a plot should be a straight line, which when extrapolated to $M=0$ gives the true free-air temperature to be used. The differences between recorded airplane temperature and the corrected landmark temperature are then plotted against the quantity $0.2TM^2$. The slope of this curve represents the recovery factor; the difference between two curves obtained for headings into

and away from the sun is a measure of the effect of solar radiation. A considerable variation of slope along the curve may signify that the recovery factor varies with changes in the flow-field pattern, in which case a more complete calibration with Mach number and lift coefficient as variables may be required.

LANGLEY MEMORIAL AERONAUTICAL LABORATORY,
NATIONAL ADVISORY COMMITTEE FOR AERONAUTICS,
LANGLEY FIELD, VA., May 16, 1946.

REFERENCES AND BIBLIOGRAPHY

GENERAL

1. Zahn, A. F.: Pressure of Air on Coming to Rest from Various Speeds. NACA Rep. No. 247, 1926.
2. Moss, Sanford A., and Smith, Chester W.: Engineering Computations for Air and Gases. Trans. A.S.M.E., vol. 52, no. 15, May-Aug. 1930, pp. 93-102.
3. Moss, Sanford A.: Fundamental Constants for Engineering Computations with Air. Gen. Elec. Rev., vol. 34, no. 8, Aug. 1931, pp. 474-476.
4. Diehl, Walter S.: Standard Atmosphere—Tables and Data. NACA Rep. No. 218, 1925. (Reprint 1940.)
5. Koteher, Ezra: The Compressibility Factor in Converting Indicated to True Air Speed. ACTR No. 4515, Matériel Div., Army Air Corps, Feb. 29, 1940.
6. Heck, Robert C. H.: The New Specific Heats. Mech. Eng., vol. 62, no. 1, Jan. 1940, pp. 9-12; Addenda to and Discussion of Paper, vol. 63, no. 2, Feb. 1941, pp. 126-135.
7. Baals, Donald D., and Ritchie, Virgil S.: A Simplified Chart for Determining Mach Number and True Airspeed from Airspeed-Indicator Readings. NACA RB, March 1943.
8. Schoenfeld, L. I.: Report on Airspeed Tables. Rep. No. NAES-INSTR-38-45, Naval Aircraft Modification Unit, Bur. Aero., Aug. 1, 1945.
9. Keenan, Joseph H., and Kaye, Joseph: Thermodynamic Properties of Air. John Wiley & Sons, Inc., 1945.
10. Aiken, William S., Jr.: Standard Nomenclature for Airspeeds with Tables and Charts for Use in Calculation of Airspeed. NACA Rep. No. 837, 1946.
11. Warfield, Calvin N.: Tentative Tables for the Properties of the Upper Atmosphere. NACA TN No. 1200, 1947.

PITOT-STATIC TUBES

12. Buckingham, E.: Investigation of Pitot Tubes. Part 2.—The Theory of the Pitot and Venturi Tubes. NACA Rep. No. 2, 1915.
13. Barker, Muriel: On the Use of Very Small Pitot-Tubes for Measuring Wind Velocity. Proc. Roy. Soc. (London), ser. A, vol. 101, no. 712, Aug. 1, 1922, pp. 435-445.
14. Ower, E., and Johansen, F. C.: The Design of Pitot-Static Tubes. R. & M. No. 981, British A.R.C., 1926.
15. Kumbrecht, H.: Pitot-Static Tubes for Determining the Velocity of Air. NACA TM No. 303, 1925.
16. Eshbaugh, J. E.: Performance of Air-Speed Tubes Exposed to Rain Drops and Freezing Rain. A.S.I.C., vol. VI, no. 549, Matériel Div., Army Air Corps, 1926.
17. Ower, E., and Johansen, F. C.: On a Determination of the Pitot-Static Tube Factor at Low Reynolds Numbers, with Special Reference to the Measurement of Low Air Speeds. R. & M. No. 1437, British A.R.C., 1932.

18. Prandtl, L., and Tietjens, O. G.: Applied Hydro- and Aeromechanics. McGraw-Hill Book Co., Inc., 1934, pp. 120 and 230.
19. Kiel, G.: Total-Head Meter with Small Sensitivity to Yaw. NACA TM No. 775, 1935.
20. Merriam, Kenneth G., and Spaulding, Ellis R.: Comparative Tests of Pitot-Static Tubes. NACA TN No. 546, 1935.
21. Lock, C. N. H., and Hilton, W. F.: Calibration of Standard Pitot-Static Heads in the High Speed Tunnel. R. & M. No. 1752, British A.R.C., 1936.
22. Walchner, O.: The Effect of Compressibility on the Pressure Reading of a Prandtl Pitot Tube at Subsonic Flow Velocity. NACA TM No. 917, 1939.
23. Hensley, Reece V.: Calibrations of Pitot-Static Tubes at High Speeds. NACA ACR, July 1942.
24. Humphreys, Milton D.: Effects of Compressibility and Large Angles of Yaw on Pressure Indicated by a Total-Pressure Tube. NACA RB No. L5C30, 1945.
25. Lindsey, W. F.: Calibrations of Service Pitot Tubes in the Langley 24-Inch High-Speed Tunnel. NACA MR No. L6A08, 1946.
40. Wildhack, W. A.: Pressure Drop in Tubing in Aircraft Instrument Installations. NACA TN No. 593, 1937.
41. Draper, C. S., and Schliestett, G. V.: Dynamic Errors of the Rate-of-Climb Meter. Jour. Aero. Sci., vol. 5, no. 11, Sept. 1938, pp. 426-430.
42. Draper, C. S., and Schliestett, G. V.: General Principles of Instrument Analysis. Instruments, vol. 12, no. 5, May 1939, pp. 137-142.
43. Johnson, Daniel P.: Aircraft Rate-of-Climb Indicators. NACA Rep. No. 666, 1939.
44. Weidemann, Hans: Inertia of Dynamic Pressure Arrays. NACA TM No. 998, 1941.
45. Kennedy, Charles: Measuring the Coulomb and Viscous Components of Friction. Instruments, vol. 15, no. 10, Oct. 1942, pp. 404-406 and 408-410.
46. De Juhasz, Kalman J.: Graphical Analysis of Delay of Response in Air-Speed Indicators. Jour. Aero. Sci., vol. 10, no. 3, March 1943, pp. 91-97.
47. Head, Richard M.: Lag Determination of Altimeter Systems. Jour. Aero. Sci., vol. 12, no. 1, Jan. 1945, pp. 85-93.

FIELD OF FLOW AROUND AN AIRPLANE

26. Bryant, L. W., and Williams, D. H.: An Investigation of the Flow of Air around an Aerofoil of Infinite Span. R. & M. No. 989, British A.R.C., 1924.
27. Tanner, T.: The Two-Dimensional Flow of Air around an Aerofoil of Symmetrical Section. R. & M. No. 1353, British A.R.C., July 1930.
28. Weing, F.: Geschwindigkeit und Richtung der Strömung um ein Tragflügelprofil. Luftfahrtforschung, Bd. 12, Nr. 7, Nov. 28, 1935, pp. 222-228.
29. Parsons, John F.: Full-Scale Wind-Tunnel Tests to Determine a Satisfactory Location for a Service Pitot-Static Tube on a Low-Wing Monoplane. NACA TN No. 561, 1936.
30. Gates, S. B., and Cohen, J.: Note on the Standardization of Pitot-Static Head Position on Monoplanes. R. & M. No. 1778, British A.R.C., 1937.
31. Delano, James B., and Wright, Ray H.: Investigation of Drag and Pressure Distribution of Windshields at High Speeds. NACA ARR, Jan. 1942.
32. Scherrer, Richard, and Rodert, Lewis A.: A Flight Investigation of Fuselage Static-Pressure-Vent, Airspeed Installations. NACA ARR No. 3K16, 1943.
33. Schoenfeld, L. I., and Harding, G. A.: Instructions for the Location, Installation and Calibration of Flush Static Vents. Rep. No. NAES-INSTR-15-44, NAF, Philadelphia Navy Yard, Bur. Aero., July 15, 1944.
34. Lindsey, W. F.: Effect of Mach Number on Position Error as Applied to a Pitot-Static Tube Located 0.55 Chord ahead of an Airplane Wing. NACA CB No. L4E29, 1944.
35. Zaloveik, John A., and Daum, Fred L.: Flight Investigation at High Mach Numbers of Several Methods of Measuring Static Pressure on an Airplane Wing. NACA RB No. L4H10a, 1944.
36. Stack, John: Compressible Flows in Aeronautics. Jour. Aero. Sci., vol. 12, no. 2, April 1945, pp. 127-143.
48. Hersey, M. D.: Diaphragms for Aeronautic Instruments. NACA Rep. No. 165, 1923.
49. Kimnard, I. F., and Faus, H. T.: A Self-Compensating Temperature Indicator. Trans. A.I.E.E., vol. XLIX, July 1930, pp. 949-951.
50. Theodorsen, Theodore: Investigation of the Diaphragm-Type Pressure Cell. NACA Rep. No. 338, 1931.
51. Beij, K. Hilding: Aircraft Speed Instruments. NACA Rep. No. 420, 1932.
52. Brombacher, W. G.: Measurement of Altitude in Blind Flying. NACA TN No. 503, 1934.
53. Peterson, John B., and Womack, S. H. J.: Electrical Thermometers for Aircraft. NACA Rep. No. 606, 1937.
54. Wildhack, W. A., and Goerke, V. H.: Corrugated Metal Diaphragms for Aircraft Pressure-Measuring Instruments. NACA TN No. 738, 1939.
55. Brombacher, W. G.: Altitude by Measurement of Air Pressure and Temperature. Jour. Washington Acad. Sci., vol. 34, no. 9, Sept. 15, 1944, pp. 277-299.
56. Anon.: Handbook of Instructions with Parts Catalog. Ratio Resistance Type Thermometers. T.O. No. 05-40B-1, Army Air Forces, Air Service Command (Patterson Field, Ohio), Oct. 1, 1943. (Revised March 15, 1944.)
57. Anon.: Overhaul Instructions for Sensitive Altimeters. T.O. No. 05-30-17, Army Air Forces and Bur. Aero., March 15, 1946. (Revised July 8, 1946.)
58. Anon.: Handbook of Instructions with Parts Catalog for Sensitive Air Speed Indicators. AN 05-10-3, Army Air Forces, Bur. Aero., and Air Council of United Kingdom, June 25, 1943. (Revised May 10, 1945.)

TEMPERATURE MEASUREMENT

PRESSURE LAG

37. Simmons, L. F. G., and Johansen, F. C.: Experiments on the Transmission of Air Waves through Pipes. R. & M. No. 957, British A.R.C., 1925.
38. Hemke, Paul E.: The Measurement of Pressure through Tubes in Pressure Distribution Tests. NACA Rep. No. 270, 1927.
39. Weems, W. R.: The Effect of Tubing on the Indications of an Airspeed Meter. Jour. Aero. Sci., vol. 3, no. 5, March 1936, pp. 165-167.
59. Harper, D. R., 3d: Thermometric Lag. Sci. Paper No. 185, Bur. Standards, 1912.
60. Henrickson, H. B.: Thermometric Lag of Aircraft Thermometers, Thermographs, and Barographs. Res. Paper No. 222, Bur. Standards Jour. Res., vol. 5, no. 3, Sept. 1930, pp. 695-709.
61. Bailey, Neil P.: The Response of Thermocouples. Mech. Eng., vol. 53, no. 11, Nov. 1931, pp. 797-804.
62. Fluid Motion Panel of the Aeronautical Research Committee and Others: Modern Developments in Fluid Dynamics. Vol. II, S. Goldstein, ed., The Clarendon Press (Oxford), 1938, pp. 628-630.
63. Hilton, W. F.: Thermal Effects on Bodies in an Air Stream. Proc. Roy. Soc. (London), ser. A, vol. 168, no. 932, Oct. 10, 1938, pp. 43-56.

64. Fishenden, M., and Saunders, O. A.: The Errors in Gas Temperature Measurement and Their Calculation. *Jour. Inst. Fuel*, vol. 12, no. 64, March 1939, pp. 5-14.
65. Franz, A.: Pressure and Temperature Measurement in Supercharger Investigations. NACA TM No. 953, 1940.
66. Kantrowitz, Arthur: Aerodynamic Heating and the Deflection of Drops by an Obstacle in an Air Stream in Relation to Aircraft Iceing. NACA TN No. 779, 1940.
67. Van der Maas, H. J., and Wynia, S.: Corrections on the Thermometer Reading in an Air Stream. NACA TM No. 956, 1940.
68. Beck, Rudolf: Thermometric Time Lag. *Trans. A.S.M.E.*, vol. 63, no. 6, Aug. 1941, pp. 531-538. (See also Discussion by L. M. K. Boelter and R. C. Martinelli, pp. 540-541.)
69. Eckert, E.: Temperature Recording in High-Speed Gases. NACA TM No. 983, 1941.
70. Eckert, E., and Weise, W.: The Temperature of Unheated Bodies in a High-Speed Gas Stream. NACA TM No. 1000, 1941.
71. Emmons, H. W., and Brainerd, J. G.: Temperature Effects in a Laminar Compressible-Fluid Boundary Layer along a Flat Plate. *Jour. Appl. Mech.*, vol. 8, no. 3, Sept. 1941, pp. A-105 - A-110.
72. Rolnick, H. A.: Pressure-Transmission Lag in Remote-Indicating Pressure-Spring Thermometers. *Instruments*, vol. 14, no. 4, April 1941, pp. 91-92.
73. Wimmer, W.: Stagnation Temperature Recording. NACA TM No. 967, 1941.
74. McAdams, William H.: Heat Transmission. Second ed., McGraw-Hill Book Co., Inc., 1942, pp. 222 and 236.
75. Marcus, L., and Harding, G. A.: Report on Determination of the Effect of Speed on Measurement of Free Air Temperature for Various Installations. Rep. No. IDS-38-42, NAF, Philadelphia Navy Yard, Bur. Aero., Sept. 28, 1942.
76. Zucrow, Maurice J.: Thermometric Lag Determination for Cylindrical Primary Elements. *Instruments*, vol. 15, no. 10, Oct. 1942, pp. 399-400, 402, and 442.
77. Noyes, Bradford: The Stem Lag of Industrial Thermometers. *Instruments*, vol. 15, no. 11, Nov. 1942, pp. 449-452, 454, 456, 457, and 492.
78. Fairchild, C. O.: The Pitfalls of Temperature Measurement. *Instruments*, vol. 15, no. 12, Dec. 1942, pp. 498-499 and 542-544.
79. King, W. J.: Measurement of High Temperatures in High-Velocity Gas Streams. *Trans. A.S.M.E.*, vol. 65, no. 5, July 1943, pp. 421-431.
80. Hottel, H. C., and Kalitinsky, A.: Temperature Measurements in High-Velocity Air Streams. *Jour. Appl. Mech.*, vol. 12, no. 1, March 1945, pp. A-25 - A-32.
81. Goodwin, W. N., Jr.: Response Time and Lag of a Thermometer Element Mounted in a Protecting Case. *Elec. Eng., Trans. Section*, vol. 64, no. 9, Sept. 1945, pp. 665-670.
82. Miller, N. P.: Heat-Flow Effects in a Resistance-Type Thermometer. *Elec. Eng., Trans. Section*, vol. 64, no. 10, Oct. 1945, pp. 678-685.

METHOD OF MEASURING AIRSPEED

83. Thompson, F. L.: Procedure for Determining Speed and Climbing Performance of Airships. NACA TN No. 564, 1936.
84. Koning, C., and DeHaas, T. P.: The Critical Velocity of a Body Towed by a Cable from an Airplane. NACA TM No. 832, 1937.
85. Thompson, F. L.: The Measurement of Air Speed of Airplanes. NACA TN No. 616, 1937.
86. Brombacher, W. G., and Houseman, M. R.: Stratosphere Balloon Altitude, Barometric and Photogrammetric. *Jour. Aero. Sci.*, vol. 5, no. 9, July 1938, pp. 355-359.
87. Danielzig, Helmut: Behavior of Static Pressure Heads at High Speeds. NACA TM No. 865, 1938.
88. Kiel, George: Measurement of the True Dynamic and Static Pressures in Flight. NACA TM No. 913, 1939.
89. Johnson, Clarence L.: A Simple Method of Measuring Landing and Take-Off Speed. *Jour. Aero. Sci.*, vol. 7, no. 2, Dec. 1939, pp. 75-76.
90. Nosker, Paul W.: Photographic Recording of Airplane Flight Demonstrations. MR No. EXP-M-51/MS97, Materiel Center, Army Air Forces, Aug. 3, 1942.
91. Schieferdecker, A., and Gebhardt, W.: Findings Obtained in Flight Measurements with the "Raethjen" Cine-Theodolite Apparatus of the German Research Institute for Soaring Flight. Translation No. 380, Materiel Command, Army Air Forces, Nov. 17, 1944.
92. Schoenfeld, L. I., and Harding, G. A.: Report on the Dual Sighting Stand and Other Methods of Calibrating Altimeter and Airspeed Installations. Rep. No. NAES-INSTR-16-44, NAF, Philadelphia Navy Yard, Bur. Aero., Aug. 15, 1944. (Issued July 1, 1945.)
93. Di Jorio, Mario: Determinazione dell'assetto di un aereo mediante l'aerofotogrammetria. *Atti di Guidonia* No. 43, 1941. (Available as R.T.P. Translation No. 1489, British Ministry of Aircraft Production, 1941.)
94. Zaloveik, John A., and Wood, Clotaire: Static-Pressure Error of an Airspeed Installation on an Airplane in High-Speed Dives and Pull-Outs. NACA RB No. L5K29a, 1946.
95. Schack, V. J.: Trailing Airspeed Bomb Checks Pitot-Static Data. *Aero Digest*, vol. 51, no. 3, Nov. 1945, p. 96.
96. Head, Richard M.: Effect of Pressure Variations on Speed Runs. *Jour. Aero. Sci.*, vol. 12, no. 3, July 1945, pp. 311-312 and 319.
97. Graham, Ernest W., and Luskin, Harold: The Determination of the Stalling Speed and the Maximum Lift Coefficient in Flight. *Jour. Aero. Sci.*, vol. 13, no. 2, Feb. 1946, pp. 95-107.

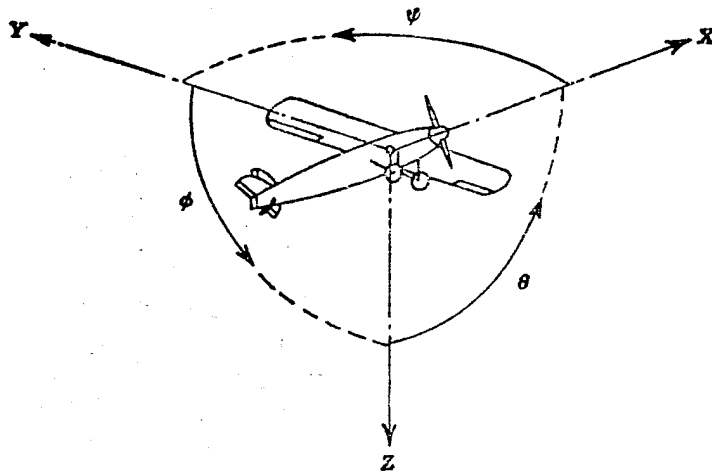

Positive directions of axes and angles (forces and moments) are shown by arrows

Axis		Force (parallel to axis) symbol	Moment about axis			Angle		Velocities	
Designation	Symbol		Designation	Symbol	Positive direction	Designation	Symbol	Linear (component along axis)	Angular
Longitudinal.....	X	X	Rolling.....	L	Y → Z	Roll.....	φ	u	p
Lateral.....	Y	Y	Pitching.....	M	Z → X	Pitch.....	θ	v	q
Normal.....	Z	Z	Yawing.....	N	X → Y	Yaw.....	ψ	w	r

Absolute coefficients of moment

$$C_l = \frac{L}{qbS} \quad C_m = \frac{M}{qcS} \quad C_n = \frac{N}{qbS}$$

(rolling) (pitching) (yawing)

Angle of set of control surface (relative to neutral position), δ . (Indicate surface by proper subscript.)

4. PROPELLER SYMBOLS

D Diameter
 p Geometric pitch
 p/D Pitch ratio
 V' Inflow velocity
 V_s Slipstream velocity

T Thrust, absolute coefficient $C_T = \frac{T}{\rho n^2 D^4}$
 Q Torque, absolute coefficient $C_Q = \frac{Q}{\rho n^2 D^5}$

P Power, absolute coefficient $C_P = \frac{P}{\rho n^3 D^5}$

C_s Speed-power coefficient $= \sqrt{\frac{\rho V'^5}{P n^3}}$

η Efficiency

n Revolutions per second, rps

Φ Effective helix angle $= \tan^{-1} \left(\frac{V}{2\pi r n} \right)$

5. NUMERICAL RELATIONS

1 hp = 76.04 kg-m/s = 550 ft-lb/sec
 1 metric horsepower = 0.9863 hp
 1 mph = 0.4470 mps
 1 mps = 2.2369 mph

1 lb = 0.4536 kg
 1 kg = 2.2046 lb
 1 mi = 1,609.35 m = 5,280 ft
 1 m = 3.2808 ft