

*R. J. McQuinn*

# NATIONAL ADVISORY COMMITTEE FOR AERONAUTICS

REPORT No. 369

## MANEUVERABILITY INVESTIGATION OF THE F6C-3 AIRPLANE WITH SPECIAL FLIGHT INSTRUMENTS

By C. H. DEARBORN and H. W. KIRSCHBAUM

168103

DTIC  
SELECTED  
AUG 28 1995  
S D  
F



DISTRIBUTION STATEMENT A  
Approved for public release  
Distribution Unlimited

1930

19950823 047

## AERONAUTICAL SYMBOLS

### 1. FUNDAMENTAL AND DERIVED UNITS

	Symbol	Metric		English	
		Unit	Symbol	Unit	Symbol
Length.....	<i>l</i>	meter.....	m	foot (or mile).....	ft. (or mi.)
Time.....	<i>t</i>	second.....	sec	second (or hour).....	sec. (or hr.)
Force.....	<i>F</i>	weight of one kilogram.....	kg	weight of one pound	lb.
Power.....	<i>P</i>	kg/m/sec.....		horsepower.....	HP.
Speed.....		km/hr.....		mi./hr.....	M. P. H.
		m/sec.....		ft./sec.....	f. p. s.

### 2. GENERAL SYMBOLS, ETC.

<p><i>W</i>, Weight, = <math>mg</math></p> <p><i>g</i>, Standard acceleration of gravity = 9.80665 m/sec.<sup>2</sup> = 32.1740 ft./sec.<sup>2</sup></p> <p><i>m</i>, Mass, = <math>\frac{W}{g}</math></p> <p><math>\rho</math>, Density (mass per unit volume). Standard density of dry air, 0.12497 (kg-m<sup>-3</sup> sec.<sup>2</sup>) at 15° C and 760 mm = 0.002378 (lb.-ft.<sup>-3</sup> sec.<sup>2</sup>).</p> <p>Specific weight of "standard" air, 1.2255 kg/m<sup>3</sup> = 0.07651 lb./ft.<sup>3</sup></p>	<p><math>mk^2</math>, Moment of inertia (indicate axis of the radius of gyration, <i>k</i>, by proper subscript).</p> <p><i>S</i>, Area.</p> <p><i>S<sub>w</sub></i>, Wing area, etc.</p> <p><i>G</i>, Gap.</p> <p><i>b</i>, Span.</p> <p><i>c</i>, Chord length.</p> <p><i>b/c</i>, Aspect ratio.</p> <p><i>f</i>, Distance from <i>c. g.</i> to elevator hinge.</p> <p><math>\mu</math>, Coefficient of viscosity.</p>
--	--

### 3. AERODYNAMICAL SYMBOLS

<p><i>V</i>, True air speed.</p> <p><i>q</i>, Dynamic (or impact) pressure = <math>\frac{1}{2} \rho V^2</math></p> <p><i>L</i>, Lift, absolute coefficient <math>C_L = \frac{L}{qS}</math></p> <p><i>D</i>, Drag, absolute coefficient <math>C_D = \frac{D}{qS}</math></p> <p><i>C</i>, Cross-wind force, absolute coefficient <math>C_c = \frac{C}{qS}</math></p> <p><i>R</i>, Resultant force. (Note that these coefficients are twice as large as the old coefficients <i>L<sub>c</sub></i>, <i>D<sub>c</sub></i>.)</p> <p><i>i<sub>w</sub></i>, Angle of setting of wings (relative to thrust line).</p> <p><i>i<sub>s</sub></i>, Angle of stabilizer setting with reference to thrust line.</p>	<p><math>\gamma</math>, Dihedral angle.</p> <p><math>\frac{Vl}{\mu}</math>, Reynolds Number, where <i>l</i> is a linear dimension. e. g., for a model airfoil 3 in. chord, 100 mi./hr. normal pressure, 0° C: 255,000 and at 15° C., 230,000; or for a model of 10 cm chord 40 m/sec, corresponding numbers are 299,000 and 270,000.</p> <p><i>C<sub>p</sub></i>, Center of pressure coefficient (ratio of distance of <i>C. P.</i> from leading edge to chord length).</p> <p><math>\beta</math>, Angle of stabilizer setting with reference to lower wing, = (<i>i<sub>t</sub></i> - <i>i<sub>w</sub></i>).</p> <p><math>\alpha</math>, Angle of attack.</p> <p><math>\epsilon</math>, Angle of downwash.</p>
--	---

E R R A T A

NATIONAL ADVISORY COMMITTEE FOR AERONAUTICS

TECHNICAL REPORT NO. 369

MANEUVERABILITY INVESTIGATION OF THE F6C-3 AIRPLANE  
WITH SPECIAL FLIGHT INSTRUMENTS

Page 19: Strike out title "Appendix" and insert it on page 21,  
above the title "Specifications of F6C-3 Airplane."

Page 19, Table I: Change "rad./sec.<sup>1</sup>" to  
rad./sec.<sup>2</sup>

Page 19, Table I: Strike out footnote "Measured with load car-  
ried in this investigation," and insert it  
as footnote No. 2, on page 21, under the  
table of specifications.

Accession For	
NTIS CRA&I	<input checked="" type="checkbox"/>
DTIC TAB	<input type="checkbox"/>
Unannounced	<input type="checkbox"/>
Justification .....	
By .....	
Distribution/	
Availability Codes	
Dist	Avail and/or Special
A-1	

---

---

**REPORT No. 369**

---

**MANEUVERABILITY INVESTIGATION  
OF THE F6C-3 AIRPLANE WITH SPECIAL FLIGHT  
INSTRUMENTS**

**By C. H. DEARBORN and H. W. KIRSCHBAUM  
Langley Memorial Aeronautical Laboratory**

## NATIONAL ADVISORY COMMITTEE FOR AERONAUTICS

NAVY BUILDING, WASHINGTON, D. C.

---

(An independent Government establishment, created by act of Congress approved March 3, 1915, for the supervision and direction of the scientific study of the problems of flight. Its membership was increased to 15 by act approved March 2, 1929 (Public, No. 903, 70th Congress). It consists of members who are appointed by the President, all of whom serve as such without compensation.)

---

JOSEPH S. AMES, Ph. D., *Chairman*,  
President, Johns Hopkins University, Baltimore, Md.  
DAVID W. TAYLOR, D. Eng., *Vice Chairman*,  
Washington, D. C.  
CHARLES G. ABBOT, Sc. D.,  
Secretary, Smithsonian Institution, Washington, D. C.  
GEORGE K. BURGESS, Sc. D.,  
Director, Bureau of Standards, Washington, D. C.  
WILLIAM F. DURAND, Ph. D.,  
Professor Emeritus of Mechanical Engineering, Stanford University, California.  
JAMES E. FECHET, Major General, United States Army,  
Chief of Air Corps, War Department, Washington, D. C.  
HARRY F. GUGGENHEIM, M. A.,  
The American Ambassador, Habana, Cuba.  
WILLIAM P. MACCRACKEN, Jr., Ph. B.,  
Washington, D. C.  
CHARLES F. MARVIN, M. E.,  
Chief, United States Weather Bureau, Washington, D. C.  
WILLIAM A. MOFFETT, Rear Admiral, United States Navy,  
Chief, Bureau of Aeronautics, Navy Department, Washington, D. C.  
HENRY C. PRATT, Brigadier General, United States Army,  
Chief, Matériel Division, Air Corps, Wright Field, Dayton, Ohio.  
S. W. STRATTON, Sc. D.,  
Massachusetts Institute of Technology, Cambridge, Mass.  
J. H. TOWERS, Captain, United States Navy,  
Assistant Chief, Bureau of Aeronautics, Navy Department, Washington, D. C.  
EDWARD P. WARNER, M. S.,  
Editor "Aviation," New York City.  
ORVILLE WRIGHT, Sc. D.,  
Dayton, Ohio.

---

GEORGE W. LEWIS, *Director of Aeronautical Research.*

JOHN F. VICTORY, *Secretary.*

HENRY J. E. REID, *Engineer in Charge, Langley Memorial Aeronautical Laboratory, Langley Field, Va.*

JOHN J. IDE, *Technical Assistant in Europe, Paris, France.*

---

### EXECUTIVE COMMITTEE

JOSEPH S. AMES, *Chairman.*

DAVID W. TAYLOR, *Vice Chairman.*

CHARLES G. ABBOT.

GEORGE K. BURGESS.

JAMES E. FECHET.

WILLIAM P. MACCRACKEN, Jr.

CHARLES F. MARVIN.

WILLIAM A. MOFFETT.

HENRY C. PRATT.

S. W. STRATTON.

J. H. TOWERS.

EDWARD P. WARNER.

ORVILLE WRIGHT.

JOHN F. VICTORY, *Secretary.*

# REPORT No. 369

## MANEUVERABILITY INVESTIGATION OF THE F6C-3 AIRPLANE WITH SPECIAL FLIGHT INSTRUMENTS

By C. H. DEARBORN and H. W. KIRSCHBAUM

### SUMMARY

*This investigation was made for the purpose of obtaining information on the maneuverability of the F6C-3 fighter airplane. The tests were conducted by the National Advisory Committee for Aeronautics at Langley Field, Va., at the request of the Bureau of Aeronautics, Navy Department. It is the first in a series of similar investigations to be conducted on a number of military airplanes for the purpose of comparing the abilities of these airplanes to maneuver, and also to establish a fund of quantitative data which may be used in formulating standards of comparison for rating the maneuverability of any airplane. A large part of this initial investigation was necessarily devoted to the development and trial of methods suitable for use in subsequent investigations of this nature.*

*Air speed, angular velocity, linear acceleration, and position of the control surfaces were measured by instruments in the airplane during loops, push-downs, pull-outs from dives, pull-ups from level flight, barrel rolls, and spins. The coordinates of the flight paths were deduced from the data whenever possible, and were checked in some cases by the use of a camera obscura. The results are given in curves showing the variation of the measured quantities with respect to time, and maximum values are tabulated.*

### INTRODUCTION

At the time that this work was started, the rating of an airplane with regard to its ability to maneuver was based largely upon individual opinions rather than upon definitely established accomplishments. Not only was there a lack of quantitative data which could be used in comparing the maneuverability of different airplanes, but there was also considerable uncertainty as to which quantities best express maneuverability. It was desirable, therefore, that a method be developed by means of which a comprehensive investigation of the various phases of the maneuverability of a number of airplanes could be made. From a collection of quantitative data obtained by this means, it should not only be possible to compare the merits of the airplanes investigated, but also to formulate a satisfactory criterion for

maneuverability and to draw definite conclusions regarding the factors which influence it.

The problem of the determination of maneuverability was attacked several years ago by recording angular velocities and linear accelerations incurred during maneuvers with a JN4-h airplane (References 1 and 2). Since then some additional data of interest on this subject have been obtained incidental to other researches. The above data, however, were not sufficiently comprehensive for the purposes outlined, and a thorough investigation of the maneuverability of a number of military airplanes has, therefore, been initiated by the National Advisory Committee for Aeronautics, at Langley Field, Va., at the request of the Bureau of Aeronautics, Navy Department.

The preliminary work in this series of investigations was conducted on an F6C-3 fighter airplane, and is reported herein. This work was devoted largely to the development and trial of methods to be employed in these tests. Instruments in the airplane were used to record linear accelerations along the three reference axes, angular velocities about these axes, the air speed, and the positions of the control surfaces throughout various types of maneuvers. From these data the flight paths of maneuvers in a vertical plane were deduced by integration. Some of the flight paths were also recorded directly by means of a camera obscura, which was fitted up for trial during the tests. This method of recording flight paths was not utilized to its best advantage, however, due to insufficient development of the camera-obscura equipment at the time of these tests.

### APPARATUS AND METHODS

#### APPARATUS

The airplane (Figure 1) used in this investigation is an F6C-3 fighter powered with a Curtiss D-12 engine rated at 425 horsepower. The principal specifications of this airplane are listed in the appendix. The gross weight of the airplane as prepared for tests was 2,920 pounds, which is 40 pounds less than the specified weight. The load carried during the tests was so distributed that the normal location of the *C. G.* of

the airplane was practically unchanged. In order to provide room for the recording instruments, it was necessary to remove the main gasoline tank and substitute a small 22-gallon underslung tank.

The instruments consisted of three angular-velocity recorders (turn meter), a performance recorder, a recording inclinometer, a 3-component recording accelerometer, and a timer. All instruments were of the

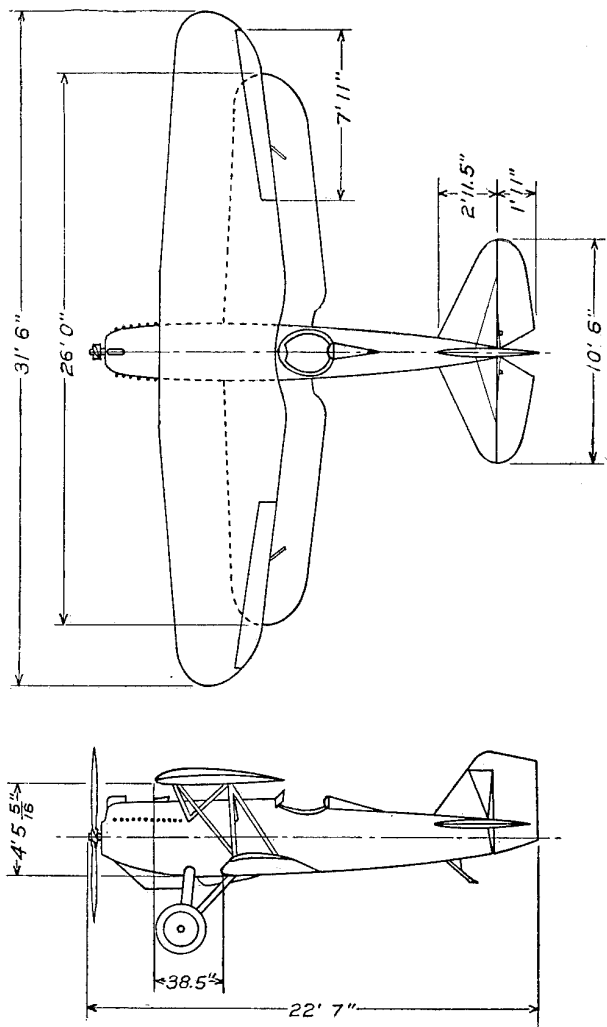

FIGURE 1.—Plan and elevation of the F6C-3 airplane

standard N.A.C.A. photographic recording type. They are described briefly below.

**Angular-velocity recorder (turn meter).**—This instrument is described in detail in Reference 1. Three of these recorders were used and so mounted in the airplane as to record the angular velocities about its three reference axes.

**Performance recorder.**—This instrument is the same as the recording air-speed meter described in Reference 3, except that altitude and temperature recording elements are incorporated in the same instrument. The air-speed diaphragm was connected to a swiveling Pitot-static head mounted on an outer

strut. The temperature recorder is of the electrical type, its operation depending upon the change of resistance of a length of wire with temperature change. The resistance wire was mounted on the under side of the lower wing near the interplane struts. The altitude element was of the usual aneroid type.

**Recording inclinometer.**—This instrument is of the oil damped pendulum type. It was installed in the airplane to record the angle between the *X* axis of the airplane and the horizontal during steady level flight preceding a maneuver.

**Three-component accelerometer.**—A description of this instrument is given in Reference 4. Linear accelerations along the three reference axes of the airplane were obtained by mounting this instrument at the *C. G.* of the airplane.

**Control-position recorder.**—This instrument, described in Reference 5, was connected to the controls to give a continuous record of their position during a maneuver.

**Timer.**—This instrument was used to synchronize, at 1-second intervals, records from the above instruments. It consists of a constant-speed motor actuating an electric interrupter through a worm gear drive. The interrupter controls the timing lights in the recording instruments. Lines produced by these timing lights are shown on a set of instrument records in Figure 2.

All instruments, with the exception of the control position recorder which was installed in the cockpit, were secured to a special mounting as illustrated in Figure 3. In order to make room for this installation and to allow for the placing of the accelerometer at the *C. G.*, the main gasoline tank had to be removed and a small specially constructed underslung tank substituted as shown on a view of the airplane in Figure 1. The instrument mounting was placed on blocks of sponge rubber to minimize the effect of vibration on the records. A master switch was located on top of the control stick for operating all instruments. The gyro motors in the angular-velocity recorders were on a separate circuit, allowing the pilot to bring them up to speed before starting the records.

Two camera-obscura installations were used in addition to the above instruments as a second method of obtaining flight paths. One of these, which was constructed under the roof of the N. A. C. A. hangar, is shown diagrammatically in Figure 4. It consists of a dark room about 6 feet square, a 46-inch focal length lens mounted in the roof at an angle of  $30^\circ$  to the horizontal, a drafting table on which film was placed, and a focal plane shutter attached to a large sheet of balloon cloth. This shutter is used to follow the airplane image and makes exposures at regular time intervals. (Reference 5.) This camera was used to photograph vertical plane maneuvers and spins. The other camera obscura with lens axis vertical was used

for determining the velocity of the wind. The same lens and shutter were used in both camera-obscura installations. Synchronization between the camera and instrument records was not attempted during this investigation.

#### METHOD OF TESTS

The flight program was drawn up to include the following maneuvers:

One low-speed and one high-speed loop.

Push-downs at 100 m. p. h. with variations of abruptness of control.

Pull-outs from dives at 140 m. p. h. with variations of abruptness of control.

Pull-ups from horizontal flight with variations of air speed and abruptness of control.

Rudder maneuvers.

mounted on frames. In executing the maneuver to be recorded, the pilot started the gyro motors in the angular-velocity recorders brought the airplane to a condition of level flight at a desired air speed, started the recording instruments, and about one second later started the maneuver. The entire maneuver was performed without changing the throttle setting, and continuous instrument and camera-obscura records were obtained, starting from the level flight condition. The same procedure, without the trial maneuver, was necessarily followed for all maneuvers whether performed before the camera obscura or not, except those performed for the determination of minimum radius of turn. In the latter case the airplane was held in a turn with full throttle setting until, in the opinion of the pilot, a condition of steady horizontal turning of minimum radius had been attained. Only a short

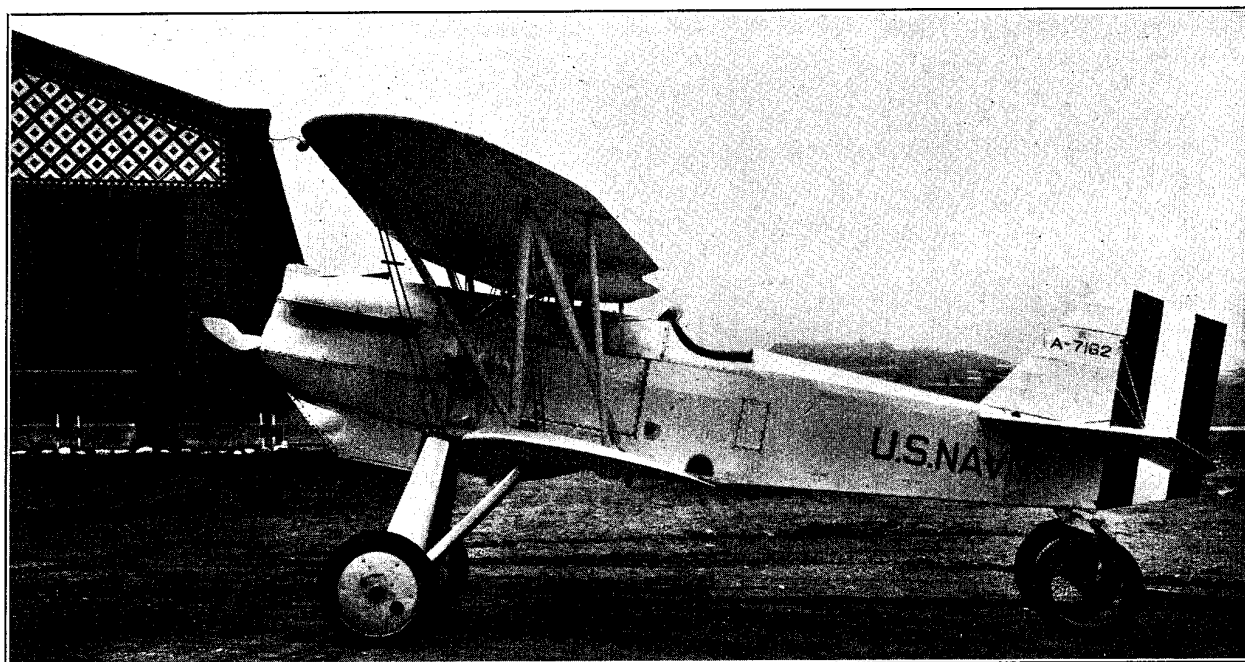

Photograph of the F6C-3

Steady horizontal turns at various air speeds for the determination of minimum radius of turn.

Right and left barrel-rolls.

Right and left spins.

Maneuvers were executed at various altitudes from approximately 3,000 to 20,000 feet, in an attempt to determine the effect of altitude on maneuverability. This attempt failed, however, to give any consistent results worthy of consideration, because of the effect at high altitudes of the low temperatures on the instruments.

When preparing to record a maneuver in the field of the camera obscura, the pilot first performed a trial maneuver during which he was guided into the camera field by ground signals employing large sheets of cloth

record was then taken, as this was sufficient for a determination of the instantaneous radius of turn. The use of a camera obscura was not feasible in this maneuver, because of the lack of a proper means of communication between the pilot and the ground station.

In connection with the use of the camera obscura it was necessary to determine accurately the direction and velocity of the wind. This was done immediately before camera-obscura records were to be taken. For this purpose another airplane was flown over the vertical camera obscura in three directions approximately 120° apart, at a constant air speed, and at the altitude in which the maneuvers were to be performed. The three paths traversed by this airplane were recorded by the camera obscura on photostat paper, and the

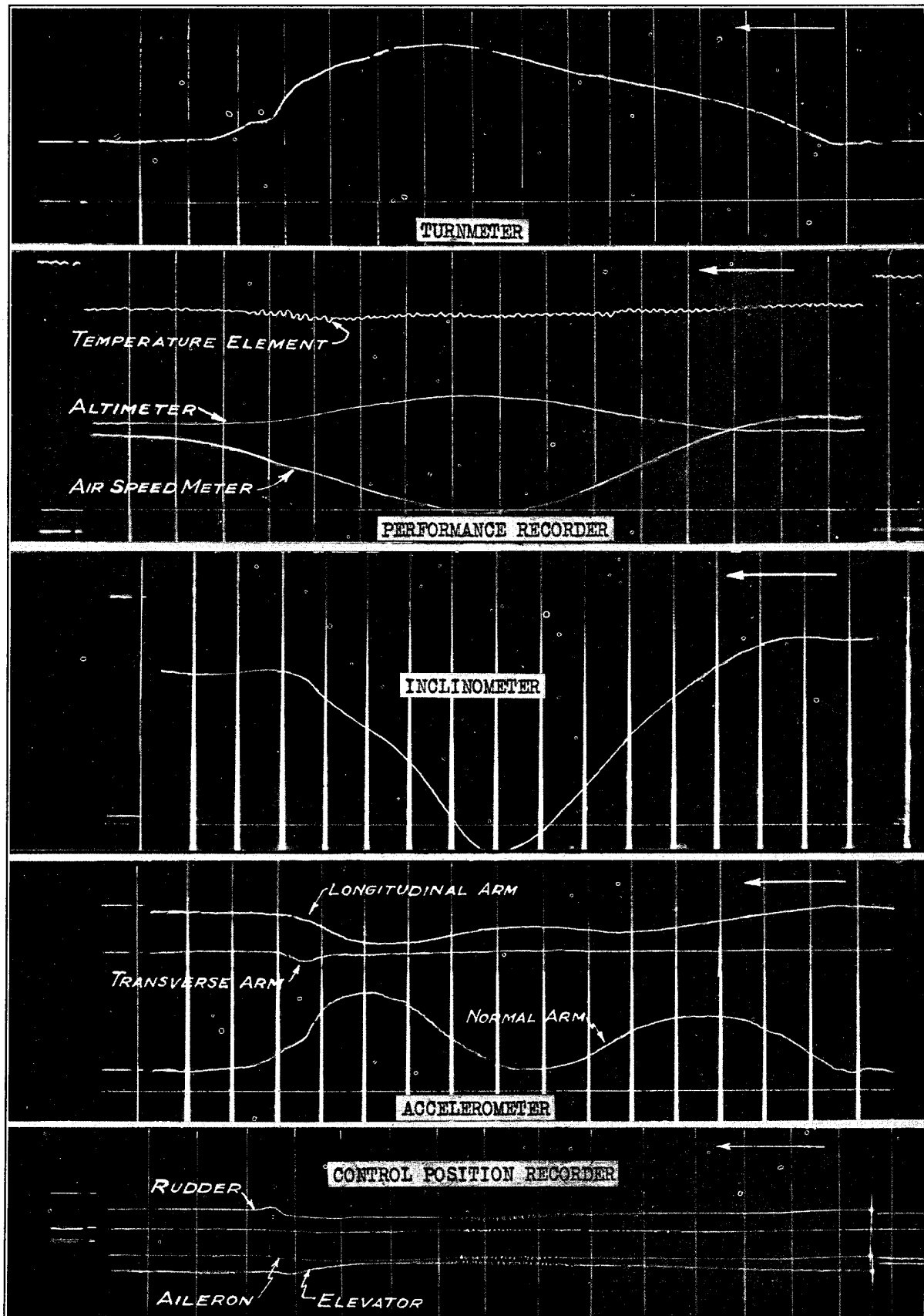

FIGURE 2.—Instrument records for a loop

wind vector was determined from these records. Since the accuracy of the camera-obscura method of determining flight path is directly dependent on the accuracy of the measured wind vectors, the camera obscura was not used when the wind was high or unsteady.

Curves showing angular velocities, linear accelerations, and control-surface position versus time were deduced directly from the records. The indicated air speed was corrected for interference, converted to true air speed, and was also plotted on the same time scale.

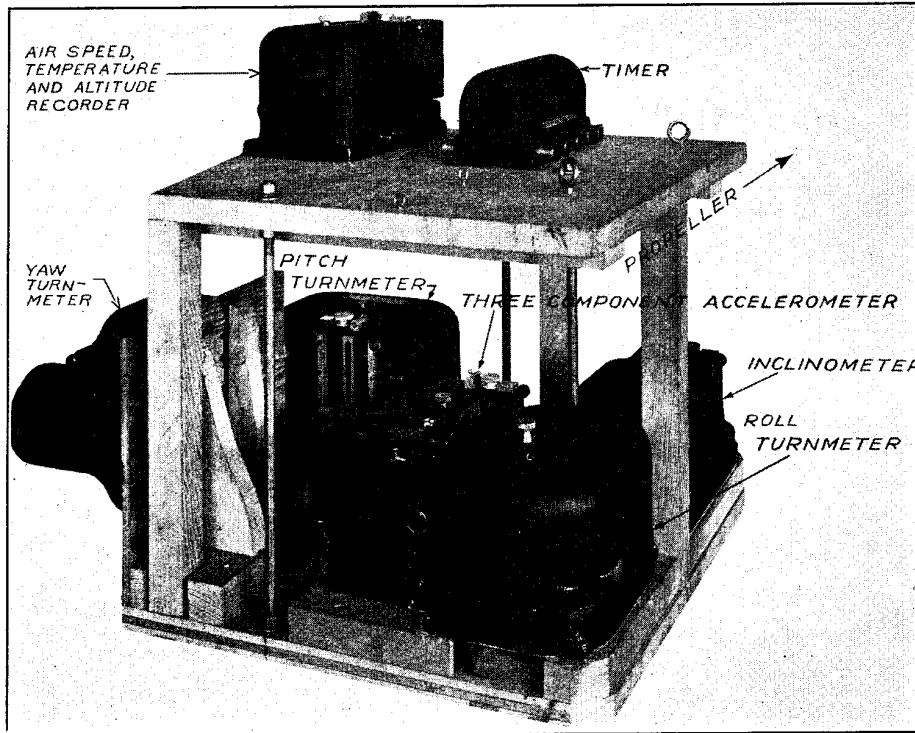

FIGURE 3.—Special instrument mounting

COMPUTATION OF RESULTS

Continuous records of the angular velocities about the three reference axes of the airplane, the linear accelerations along these axes, the air speed, the position of the three control surfaces, the air tempera-

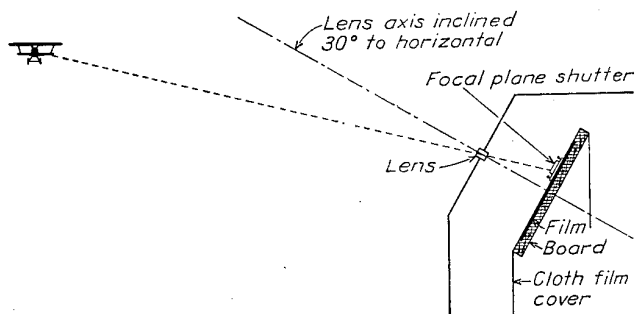

FIGURE 4.—General arrangement of oblique camera obscura

ture, and the air pressure were obtained in the various types of maneuvers. The attitude of the airplane in steady flight at the start or completion of a maneuver also was obtained by means of the recording inclinometer. During accelerated flight, however, this instrument does not give a correct indication of the airplane's attitude. Sample records obtained on the recording instruments in a loop are shown in Figure 2.

The correction for interference was found from speed course runs on a similar airplane and the factor for conversion from indicated to true air speed from the recorded air temperature and pressure.

The control position record showed the movement of the left aileron, and since the airplane was fitted with differential aileron control, a curve (Figure 5) showing the relative motion of the two ailerons has been included. Angular accelerations were found by a graphical differentiation of the angular velocity curves and were plotted on the time scale. The resultant angular velocity for maneuvers in which rotation occurred about more than one axis also was determined by adding the components vectorially and plotting versus time.

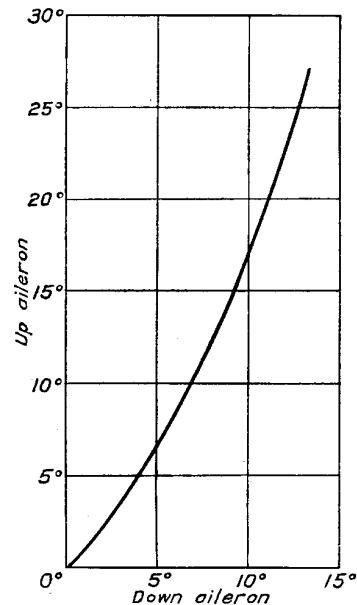

FIGURE 5.—Differential aileron action on F6C-3 airplane

The radius of horizontal turn and the corresponding air speed were computed from the recorded angular velocities and linear accelerations by means of the following equations for uniform circular motion:

$$R = \frac{a_n}{\omega_r^2} \quad (1)$$

$$V = R\omega_r \quad (2)$$

$$a_n = \sqrt{a_r^2 - g^2} \quad (3)$$

where

$R$  = Radius of turn.

$V$  = Air speed.

$a_r$  = Resultant of the three recorded accelerations.

$a_n$  = Component of acceleration due to rotation.

$\omega_r$  = Resultant angular velocity.

The acceleration,  $a_n$ , which is normal to the axis of turn was found by deducting vectorially the effect of

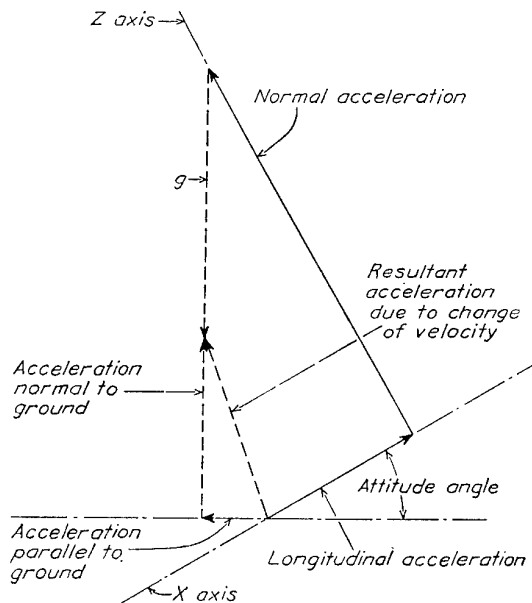

FIGURE 6.—Resolution of linear accelerations into horizontal and vertical components

gravity from the resultant recorded acceleration as indicated by equation (3). The minimum radius of turn of the airplane was determined from a curve in which the computed radii were plotted versus air speed.

Flight paths were determined from instrument records for vertical plane maneuvers in which all rotation occurred about an axis parallel to the  $Y$  axis of the airplane. The first step is the determination of angular displacement from the recorded angular velocity curves by integration. The integration was performed mechanically by means of an integrator run over photographic enlargements of the original angular

velocity records. The constants of integration were determined from the attitude of the airplane at the start of the maneuvers as recorded by the inclinometer. The attitude of the  $X$  axis at any instant was then found by adding this constant to the angle given by the ordinate of the integral curve for that instant. The vertical and horizontal components of the acceleration due to rotation and change in linear velocity were then found by graphical means, as illustrated in Figure 6. The recorded accelerations along the  $X$  and  $Z$  axes were added vectorially by laying off vectors in the directions of these axes at intervals throughout the maneuvers. A vertical acceleration of one  $g$  was then subtracted from the sum of these two vectors and the remaining vector divided into vertical and horizontal components. Curves of horizontal and vertical accelerations versus time were then obtained by plotting these values.

The second step in the determination of the flight path is the integration of the acceleration curves to obtain displacements. These acceleration curves were mechanically integrated twice by means of the integrator. The first integration gave the velocity components to which it was necessary to add the proper constants of integration. As the maneuvers were started from level flight, the horizontal constants were given by the true air speed at the start of the maneuvers and the vertical constants were zero. Horizontal and vertical displacement curves were then obtained from the velocity curves by a second integration.

The flight paths were plotted from the displacement curves thus obtained. The attitude of the airplane throughout the maneuvers was known from previous integration of the angular velocity curves. It was, therefore, possible to determine angles of attack by measuring the angles between the  $X$  axis and tangents to the flight path throughout the maneuvers.

True flight paths for vertical plane maneuvers recorded by the camera obscura were obtained graphically by applying a perspective correction and a wind correction to the recorded paths. The perspective correction is necessitated by the fact that the plane of the maneuvers was vertical while the film was placed at an angle of  $30^\circ$  to the vertical. The procedure is comparable to the construction of a map from an aerial photograph of level country, taken when the optical axis of the camera is inclined to the vertical.

The wind correction is required because the camera obscura records the path with respect to the ground, rather than the desired path with respect to the air. The wind velocities were determined graphically from the photographic records obtained in the wind runs made immediately before the maneuvers. The scales of the corrected paths were determined by the size of the airplane image.

**PRECISION OF RESULTS**

All instruments used during this investigation were calibrated at frequent intervals to minimize the error due to change of calibration. It was found that the deflections on most of the film records could be measured with a precision of 0.01 inch. The error in determining the final quantities, therefore, depends upon the sensitivity of the instruments, considered as the number of units per inch of deflection. With the sensitivities used throughout this investigation, linear accelerations are accurate to  $\pm 0.05g$ , control surface

the maneuvers. The principal error in flight paths deduced from the camera-obscure records is due to inaccuracy in the determination of the wind vectors. For the results included in this report, the total error due to this and other causes is believed to be of about the same magnitude as for the flight paths determined by the instrument method.

From the data obtained during the tests, the angles of attack in maneuvers could not be ascertained with any great degree of accuracy; therefore, the angle of attack curves presented for a number of the maneuvers

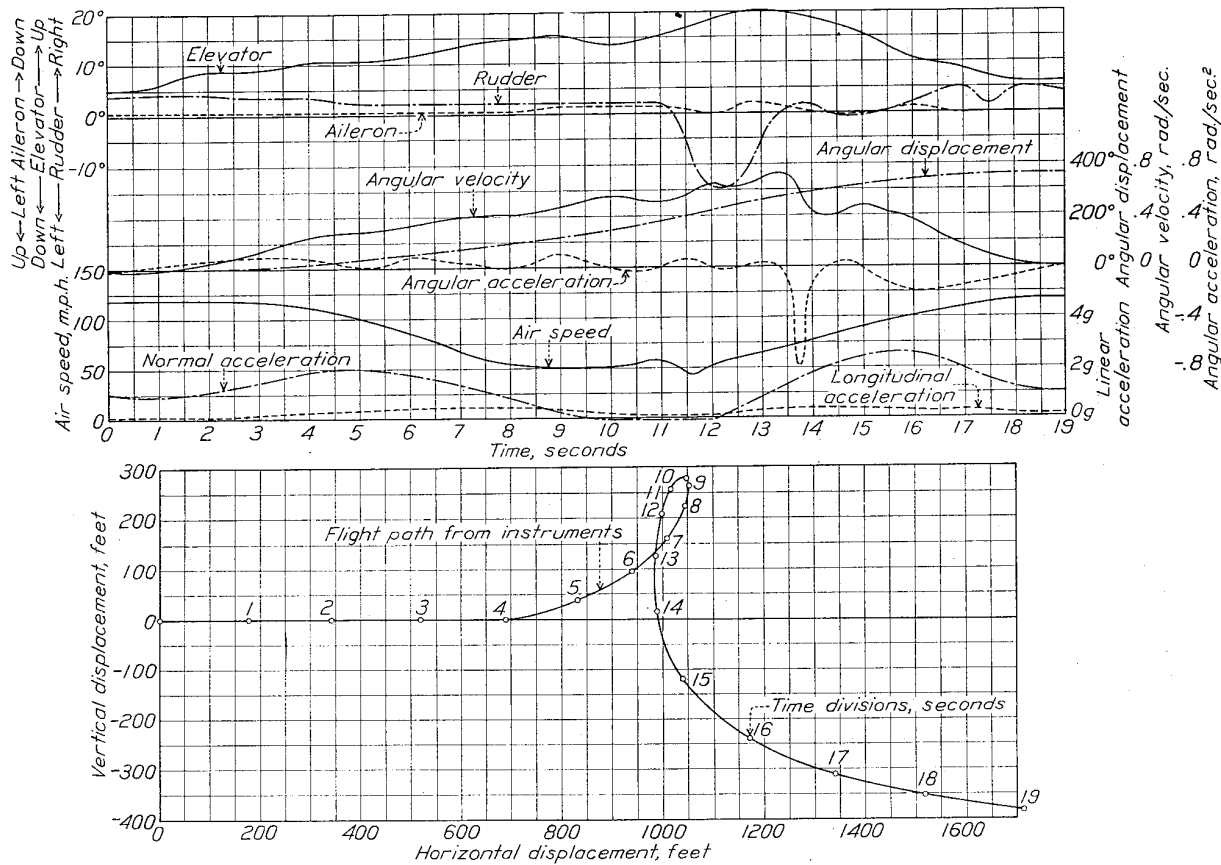

FIGURE 7.—Low-speed loop

angles to  $\pm 1^\circ$ , and inclinometer angles to  $\pm 0.25^\circ$  for steady flight. The error in the air speed is no greater than 2 per cent for unaccelerated flight. The air speed error is considerably higher for accelerated flight and apparently depends upon the violence of the maneuver. Bench angular-acceleration tests on the angular-velocity recorders would indicate that in the case of abruptly executed maneuvers the peak values are probably about 2 per cent low, and in addition to this magnitude error there is a slight time-lag error.

The instrument method of flight-path determination is subject to cumulative error in computation of results in addition to the errors in recorded values. It is considered that the flight path is accurate within 5 to 10 per cent, depending upon the length and abruptness of

should be treated only as indicative of the general trend.

**RESULTS**

Curves showing the variations of control position, angular velocity, angular acceleration, angular displacement, air speed, and linear accelerations with time are presented for each maneuver. Flight paths are included for vertical plane maneuvers. Data are presented in the following order:

- Loops—Figures 7 and 8.
- Push-downs—Figure 9.
- Pull-outs from dives—Figures 10 and 11.
- Pull-ups from horizontal flight—Figures 12 to 14, inclusive.
- Rudder maneuvers—Figure 15.

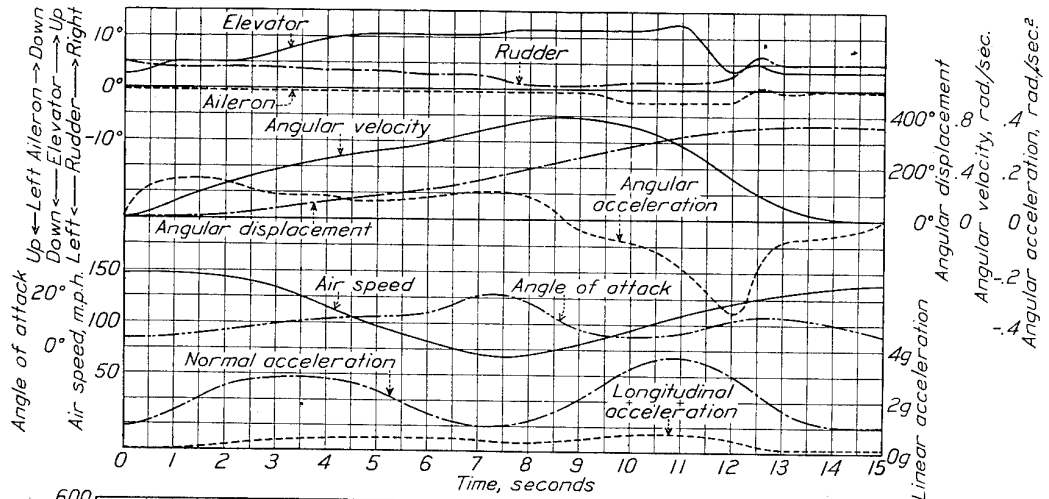

FIGURE 8.—High-speed loop

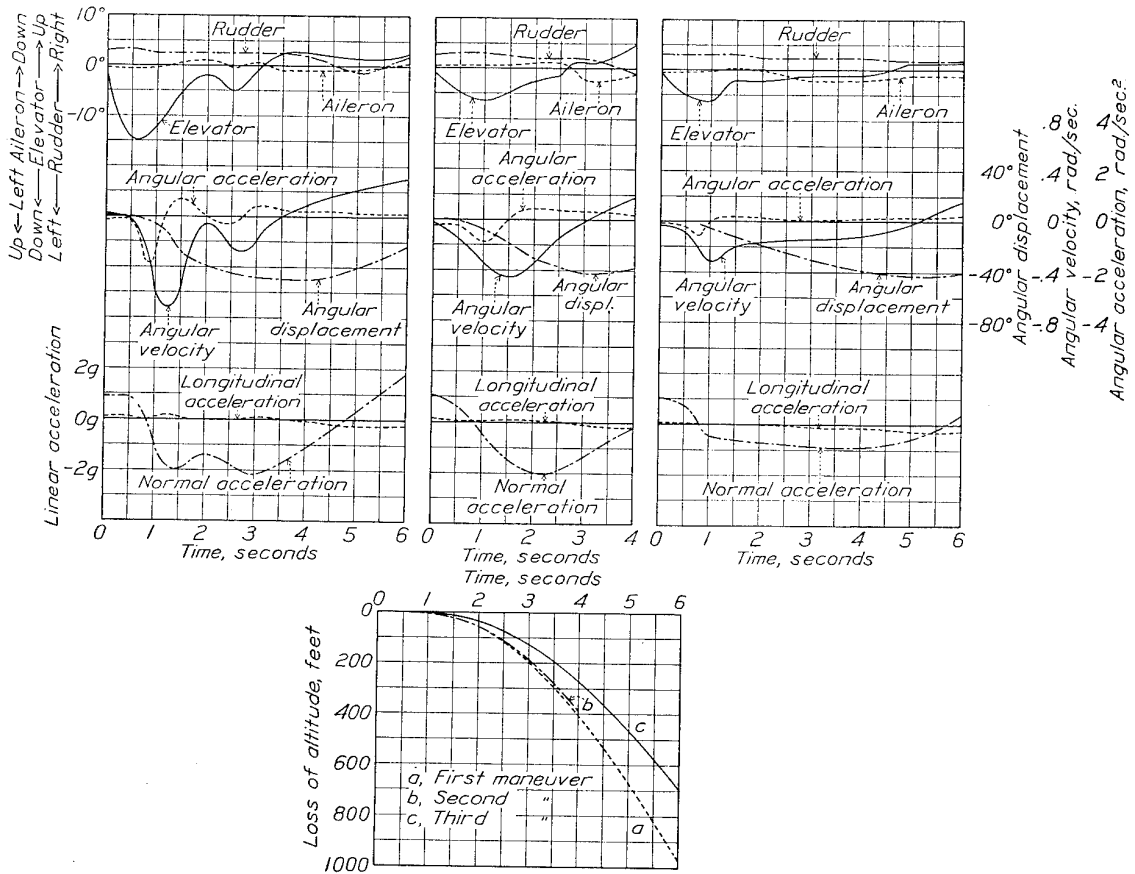
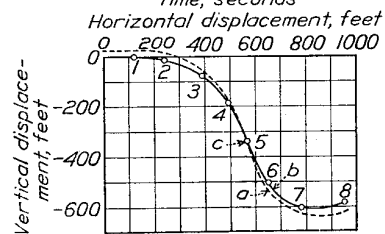
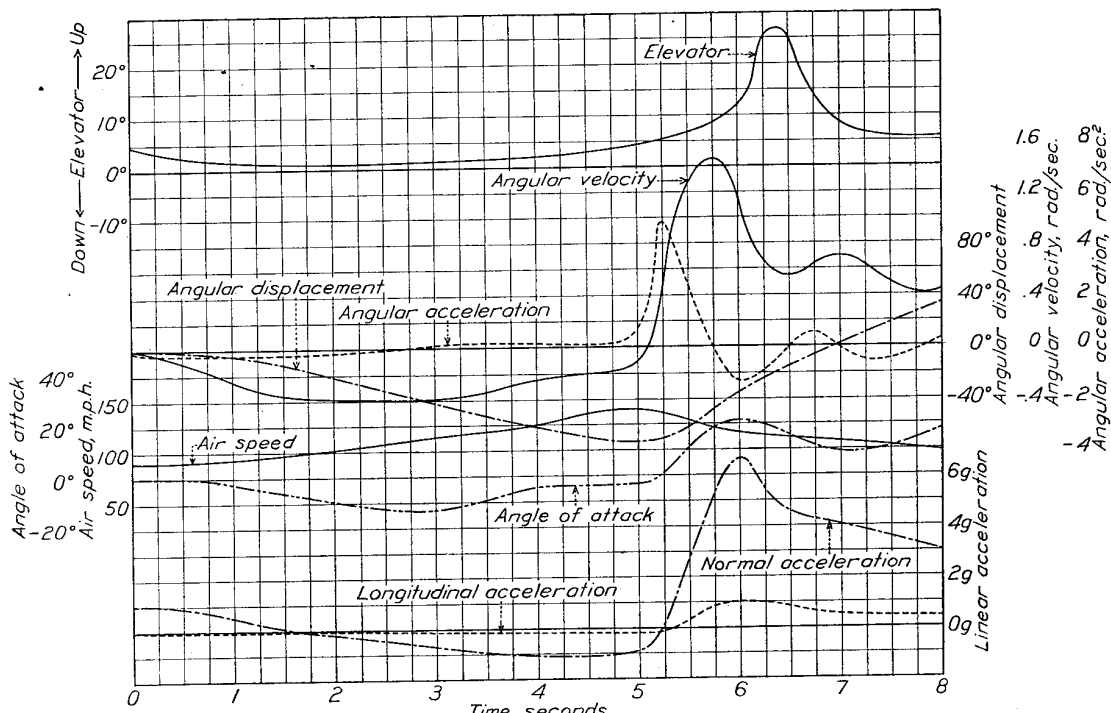

FIGURE 9.—Push-downs



- a, Flight path from camera obscura
- b, Flight path from instruments
- c, Time divisions, seconds

FIGURE 10.—First pull-out from dive

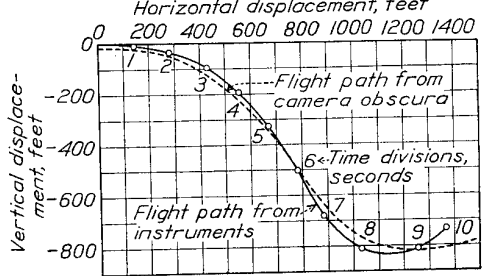
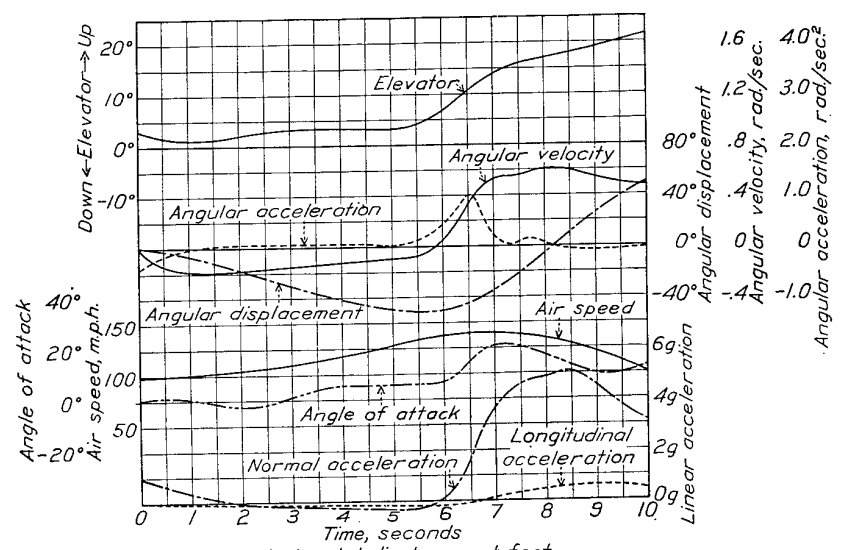

FIGURE 11.—Second pull-out from dive

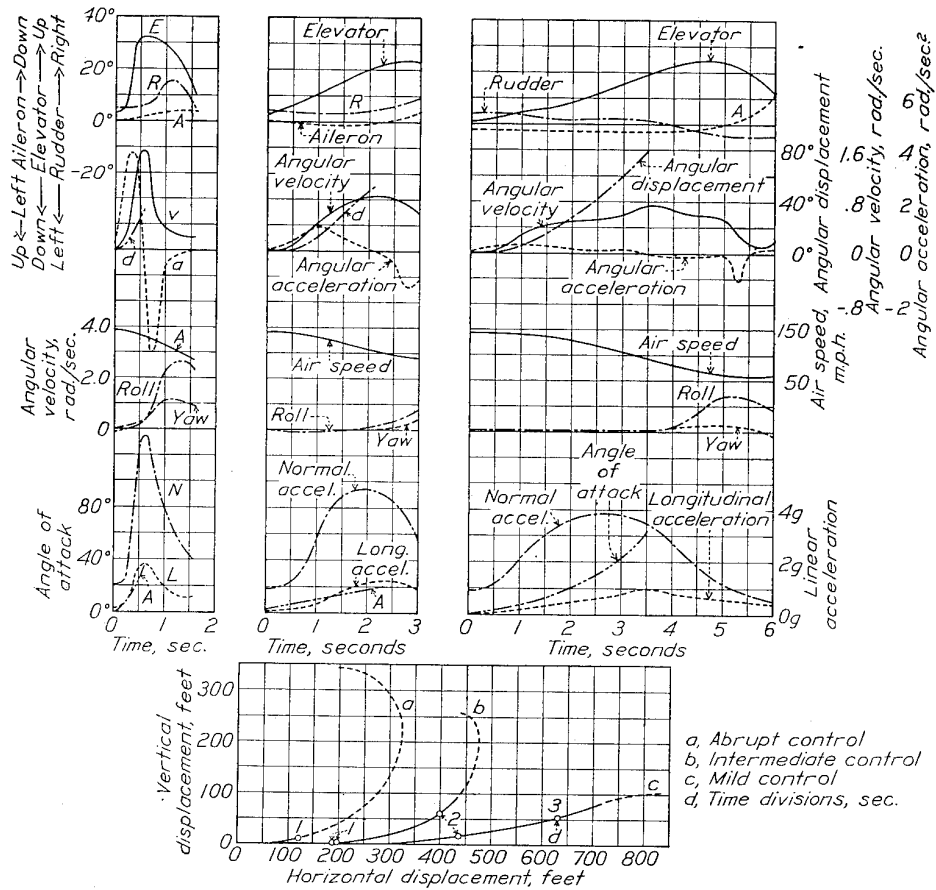

FIGURE 12.—140 m. p. h. pull-up maneuvers, three methods of control

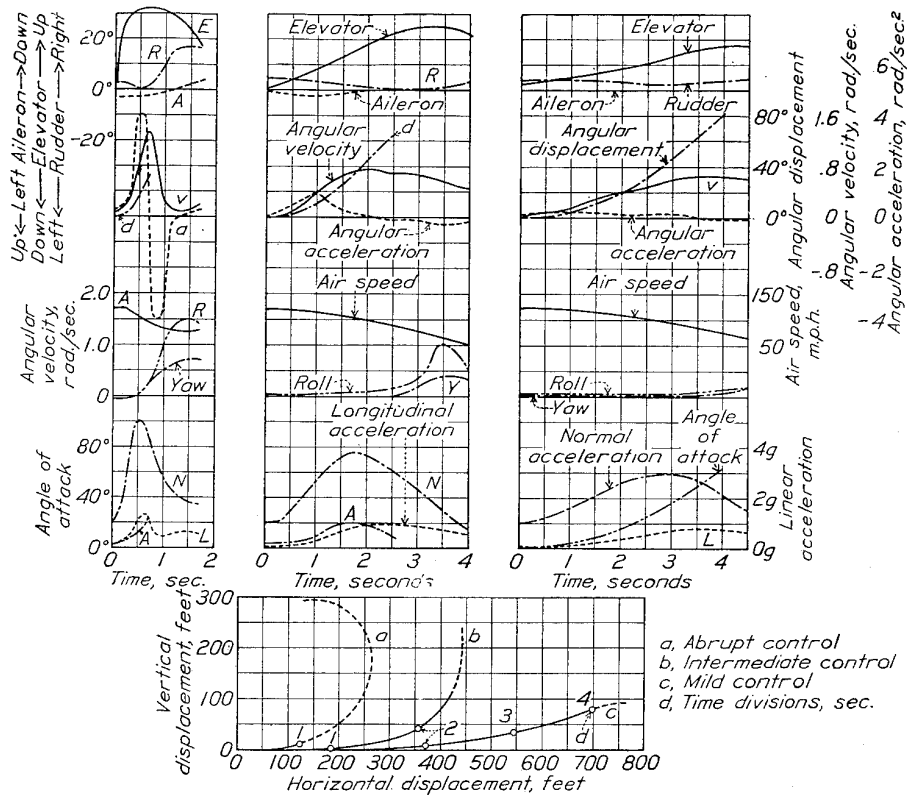

FIGURE 13.—120 m. p. h. pull-up maneuvers, three methods of control

Radius of turn—Figure 16.

Barrel-rolls—Figures 17 and 18.

Spins—Figures 19 to 21, inclusive.

The results obtained in the various types of maneuvers are described below.

**Loops.**—The two loops shown in Figures 7 and 8 were started at air speeds of 119 and 147 m. p. h.,

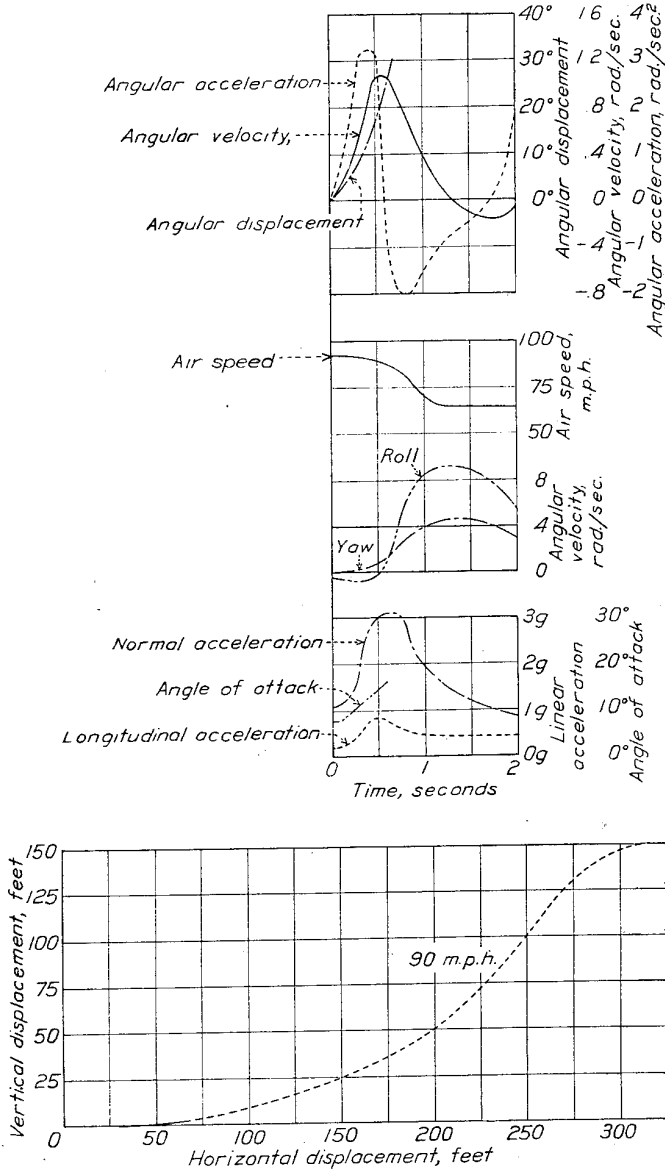

FIGURE 14.—90 m. p. h. abrupt pull-up maneuver

respectively. The elevator-deflection, angular-velocity, and angular-acceleration curves are noticeably more irregular throughout the low-speed maneuver, and the maximum elevator deflection is considerably greater at low speed. The flight paths show that the high-speed loop was executed without loss of altitude, whereas in the low-speed one level flight was regained about 380 feet below the initial position of the airplane. The normal-acceleration curves for both maneuvers

are similar in shape throughout, but the values are approximately 1g greater in the high-speed loop. A maximum value of 3.7g was attained. It occurred while leveling out near the end of the loop. Maximum

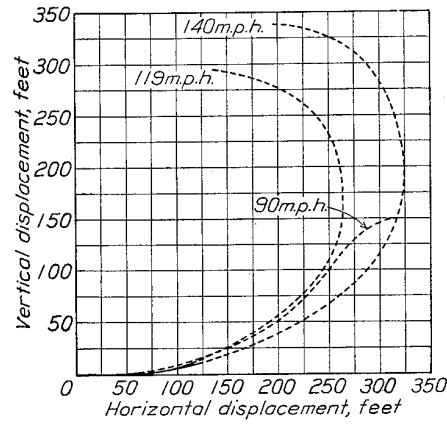

FIGURE 15.—Comparison of flight paths for abrupt pull-ups

values of angular velocity of the airplane about its lateral axis are 0.79 radian per second in the high-speed loop and 0.72 radian per second in the other case. The former value, however, occurred at the top of the loop and the latter about 3 seconds after the top.

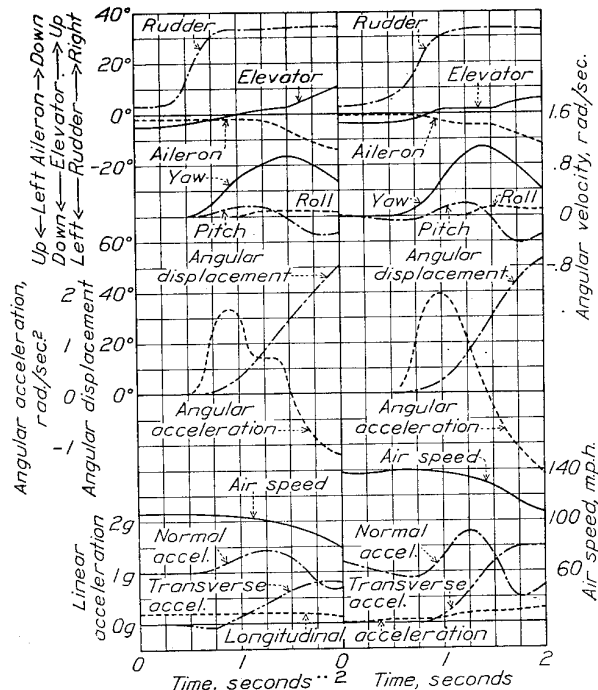

FIGURE 16.—Right rudder maneuvers

It has been previously stated that the interference correction for unaccelerated flight which has been applied to the recorded air speeds, apparently is not sufficient for conditions of accelerated flight. This is shown by the manner in which the air speed varies throughout the loops. The records in Figure 7 show

a uniform speed to be maintained from about 1½ seconds before reaching the top of the loop to the top

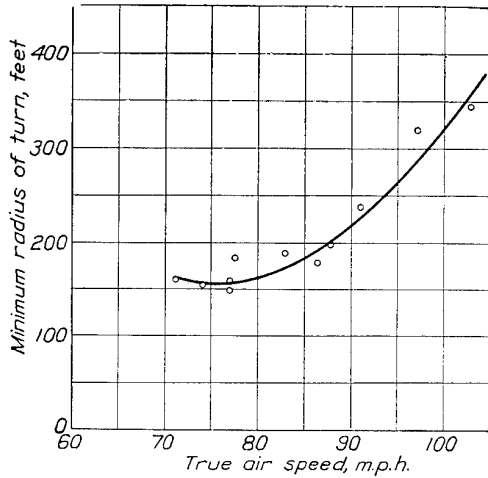

FIGURE 17.—Minimum radius of turn versus air speed

of the loop, and that a sharp irregularity occurs after the top of the loop is passed. It seems probable that the air speed actually decreases uniformly until the top of the loop is reached, and then begins to increase

of attack for a given air speed, whereas in level flight, which was used to determine the interference corrections, there is only one angle of attack for each speed.

In addition to the flight path determined from instrument records, that obtained by the camera obscura is also shown in Figure 8. Although the paths are not identical, the dimensions of the closed loop are nearly so, and the total gain and loss in altitude are in fair agreement.

**Push-downs.**—The curves in Figure 9 show the results obtained with different elevator movement in three push-downs started from a speed of approximately 100 m. p. h. The air-speed recorder failed in these maneuvers, and thus made it impossible to determine the actual flight paths. There are included, however, flight paths which were secured by assuming the air speed at the start of the maneuvers to be 100 m. p. h. for comparative purposes, showing the variations of altitude with time.

The first maneuver, which was executed by deflecting the elevator 15° abruptly, resulted in the greatest angular velocity and normal acceleration, -0.72 radian per second and -2.20g, respectively. It is interesting to note, however, that the maximum normal

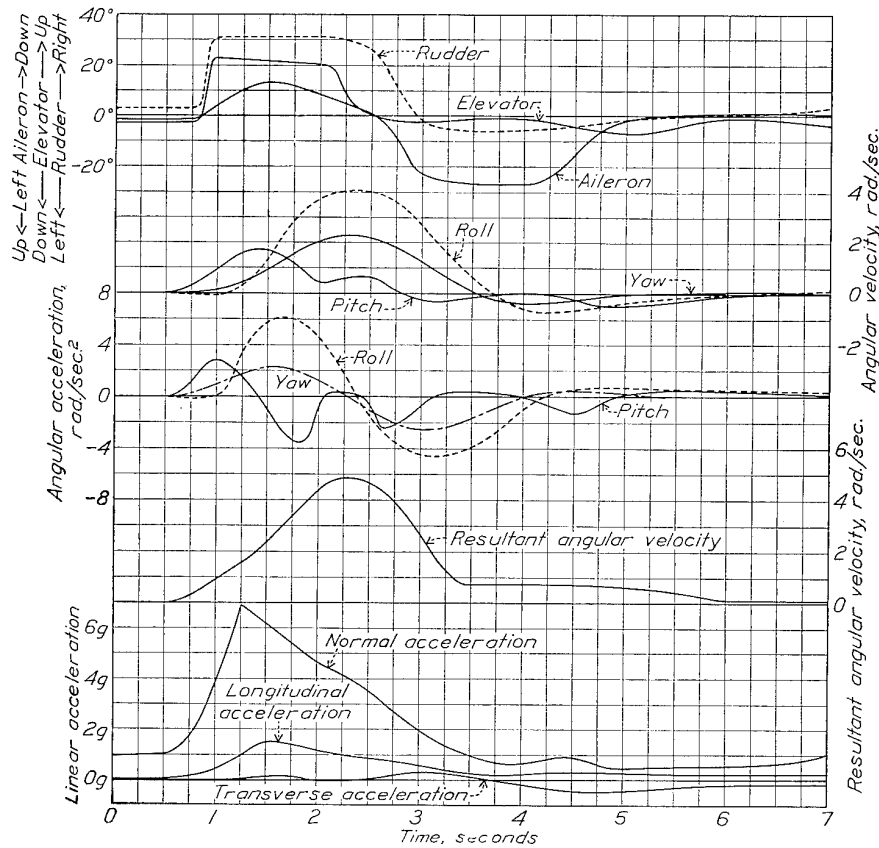

FIGURE 18.—Right barrel roll started at 147 m. p. h.

uniformly from this point to the level flight condition, and also that it does not reach as low a value as is indicated. This is based on the fact that in accelerated flight it is possible to have any number of angles

acceleration in the second maneuver was nearly as great as in the first one, although the elevator was not deflected nearly as far nor as abruptly as in the first case. With the abrupt control movement the air-

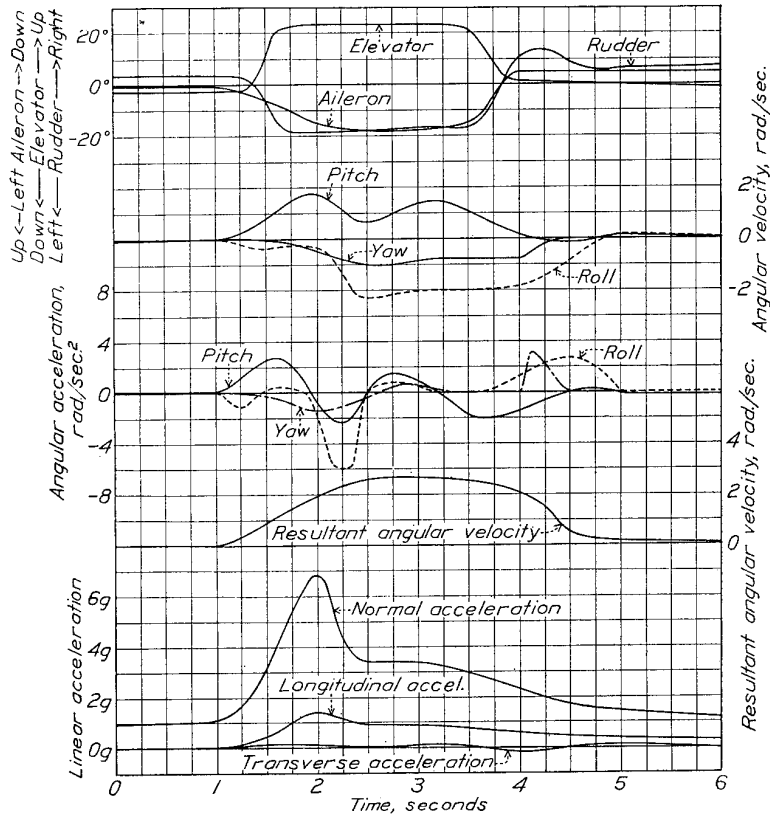

FIGURE 19.—Left barrel-roll started at 140 m. p. h.

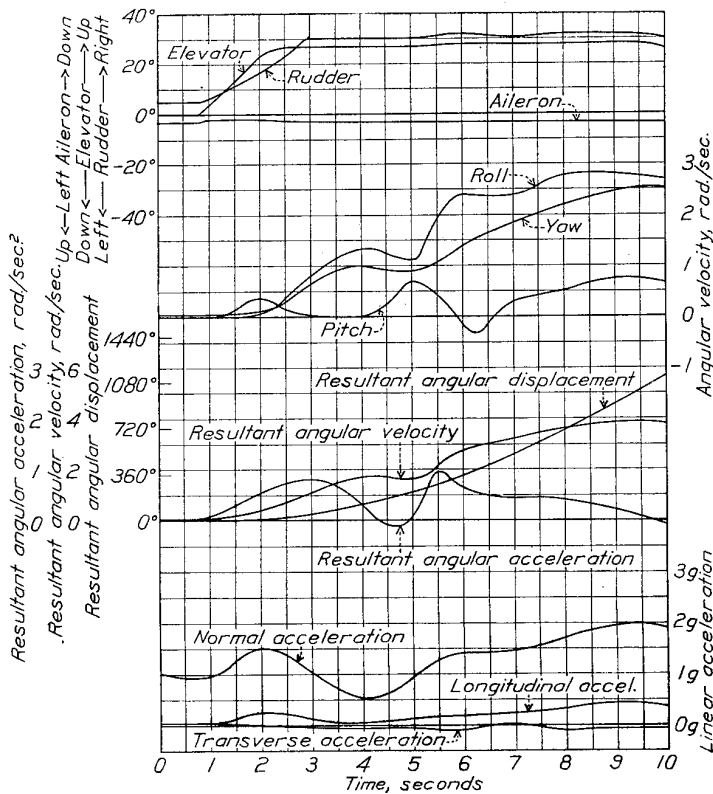

FIGURE 20.—Right spin

plane did not respond appreciably until one-half second after the control movement started, whereas the response was much quicker with the gradually applied elevator.

**Pull-outs from dives.**—Two pull-outs from dives (Figures 10 and 11) were recorded primarily to determine the altitude necessary for recovery from this type of maneuver. Controlling for leveling out from the dives was started when an air speed of about 140 m. p. h. was reached. The control movement for the first maneuver was more abrupt than for the second, and inclinations of flight paths to the horizontal at the time of controlling were about  $70^\circ$  and  $55^\circ$ , respectively. The instrument-record flight paths show losses of altitude in recovery of 310 feet in about 2.5 seconds for the first and 500 feet in 3.5 seconds for

The curves in Figures 12 and 13 show the results for the three methods of control at approximate speeds of 140 m. p. h. and 120 m. p. h., respectively. Figure 14 shows an abrupt pull-up at 90 m. p. h. Figure 15 gives a comparison of the flight paths for the abrupt maneuvers of Figures 12, 13, and 14. Control positions are not shown in Figure 14 because the recorder failed, but the elevator action is similar to that for the other abrupt maneuvers. The latter dotted portions of the flight-path curves in all three figures were determined from the camera obscura and the solid portions from instrument records. This was done because the rolling and yawing of the airplane during the latter parts of the maneuvers rendered the calculation of flight paths from instrument

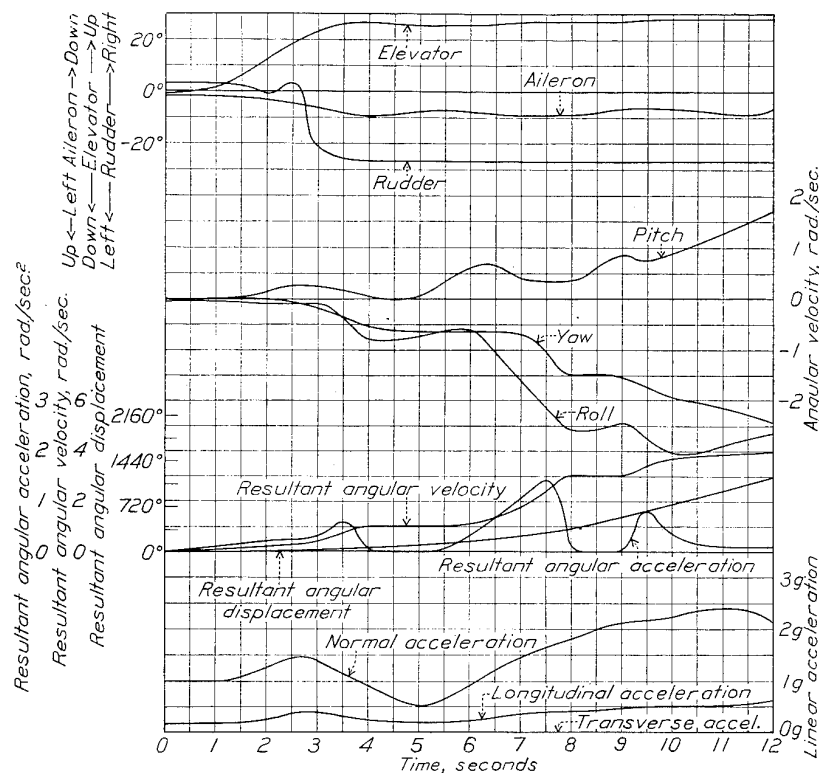

FIGURE 21.—First left spin

the second maneuver. Flight paths derived from the camera obscura are also presented. The maximum normal accelerations recorded were  $6.60g$  and  $5.05g$ , respectively. The maximum angular velocity was 1.45 radians per second for the first pull-out and 0.60 radian per second for the second pull-out.

**Pull-ups from horizontal flight.**—Data obtained in these maneuvers with three methods of elevator control at different speeds are shown in Figures 12, 13, and 14. The three methods of elevator control are termed "abrupt," "intermediate," and "mild." The abrupt method consisted in pulling the control stick all the way back as quickly as possible. The control movements were smaller and less rapid in the intermediate and mild maneuvers.

records impracticable. Since the camera-obscura records were not synchronized with instrument records, the joining of the curves was accomplished by superimposing the camera-obscura curves on the portions of the curves determined by instruments.

Figures 12 and 13 show that the effect of varying the method of control from abrupt to mild is a consistent variation in the altitude gained and the violence of the maneuvers. A comparison of the abrupt pull-ups at different speeds shows, however, that all the quantities measured did not vary in the same order as the speed. The three abrupt pull-ups were started from true air speeds of 142 m. p. h., 119 m. p. h., and 90 m. p. h., respectively. The greatest normal and longitudinal accelerations, the greatest

angular velocity, and the least time for a rotation of 30° in pitch occurred in the first maneuver. These values are 6.65g, 1.8g, 1.55 radians per second, and 0.55 second, respectively. The smallest values for these quantities occurred at the lowest speed. The maximum angular acceleration, however, is 4.0 radians per second<sup>2</sup> in the 119 m. p. h. pull-up, while the maximum values in the 142 m. p. h. and 90 m. p. h. maneuvers are 3.7 radians per second<sup>2</sup> and 3.2 radians per second<sup>2</sup>, respectively. A comparison of the flight paths for these three pull-ups (Figure 14) shows that vertical displacements varied in the same order as the speeds, but that the minimum horizontal displacement occurred in the 119 m. p. h. maneuver.

0.80g for the first and 1.50g for the second maneuver. The time for 45° displacement about the Z axis was 1.60 seconds for the first and 1.50 seconds for the last maneuver.

**Radius of turn.**—The results of a series of runs made to determine the minimum radius of turn are given in Figure 17. The minimum value from the average curve is 155 feet at an air speed of 76 m. p. h. The computed centrifugal acceleration for this turn is 2.5g, the angle of bank is 68° and the angle of attack which is the arctangent of the ratio of longitudinal and normal accelerometer readings was found to be 12°.

**Barrel rolls.**—The results obtained in two barrel-rolls are given in Figures 18 and 19. The maneuver of Figure 18 was a right roll started at a speed of 147

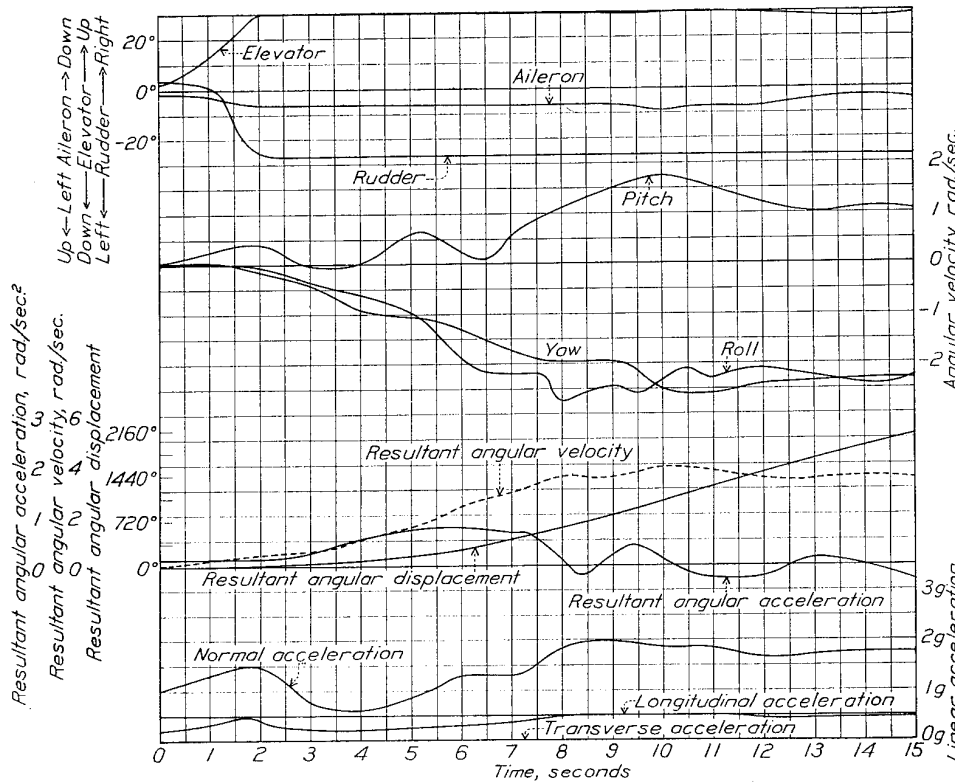

FIGURE 22.—Second left spin

**Rudder maneuvers.**—Two rudder maneuvers (Figure 16) are included primarily for the purpose of indicating the rate of change of attitude about the Z axis and the accompanying transverse acceleration produced by an abrupt movement of the rudder. The first maneuver was executed at 105 m. p. h. with a rudder movement of 33° in about 0.6 second, while the speed of the second maneuver was 141 m. p. h. with a rudder displacement of 33° in about 1 second. A maximum angular velocity about the Z axis of 0.95 radian per second for the first maneuver and 1.10 radians per second for the second were recorded with the corresponding angular accelerations of 1.7 radians per second<sup>2</sup> and 2.0 radians per second<sup>2</sup>, respectively. The maximum transverse accelerations recorded were

m. p. h., and that of Figure 19 a left roll started at a speed of 140 m. p. h. There was also a difference in the control movements. The rudder and elevator were applied more abruptly, and the rudder deflection was much greater in the right roll than in the left one. An angular velocity of 4.00 radians per second about the X axis and a resultant of 4.80 radians per second were attained in the first maneuver. The maximum angular velocities for the second maneuver were slightly more than one-half as great. There was but little difference in the maximum normal accelerations in the two maneuvers, however, as 6.90g was attained in the right roll and 6.80g in the left.

**Spins.**—Two right and two left spins were recorded. The data for only one right spin are included (Figure

20), as the results obtained in these two spins were practically identical. Data are included, however, for both left spins (Figures 21 and 22) as an appreciable difference was noted in the results. All the spins were started from level flight at about 78 m. p. h. with the engine throttled to give 800 to 900 r. p. m. during the resultant spins. In going into the spins the elevator and the rudder were moved simultaneously through large angles much in the same manner as for the barrel rolls. The ailerons either were not used or to a lesser

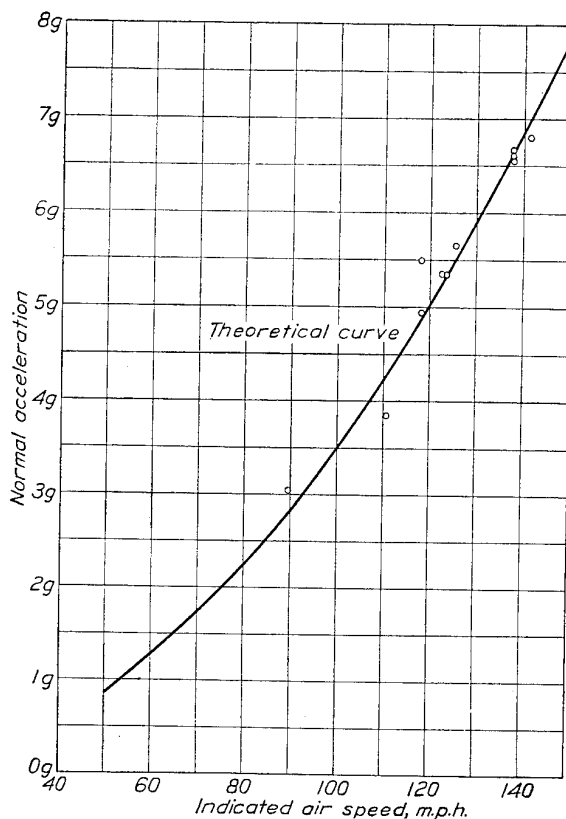

FIGURE 23.—Normal acceleration versus indicated air speed for abrupt pull-ups

extent than in the rolls. Angular velocity and linear acceleration values fluctuated considerably during the first part of the spins, but the records for the latter part of the spins indicated that nearly steady conditions were attained. The maximum angular velocities of 2.80 radians per second for the right spin, 3.05 radians per second for the first left spin, and 2.75 radians per second for the second left spin were recorded about the *X* axis with values about the *Z* axis of slightly less magnitude. The angular velocity curve for rotation about the *Y* axis indicates the least uniform rate of increase of velocity. A maximum normal acceleration of 2.40g was recorded during the first left spin, while 2.00g was reached in the other two spins. The radius of the spiral path determined from the camera obscura was found not to exceed 5 feet. It is probable that if these spins had been held for a longer duration of time, more uniform conditions would have been reached giving a closer agreement of data.

## SUMMARY OF RESULTS

Table I summarizes the principal results of this investigation. The times given in this table were measured from the instant the controls were moved from their normal positions. It may be seen that the greatest resultant angular velocity (4.80 radians per second) and the greatest normal acceleration (6.90g) occurred in the right barrel-roll at 147 m. p. h. The angular velocities attained in spins were also fairly large, and the normal accelerations in pull ups at about 140 m. p. h. were but little less than that attained in the barrel-roll.

Figure 23 shows the variation of maximum normal acceleration with air speed. The curve gives the theoretical relationship between velocity and normal acceleration. This is expressed by the formula  $a_n = \frac{V_o^2}{V_{min}^2}$ , in which  $a_n$  is the normal acceleration,  $V_o$  the initial air speed in an abrupt pull up, and  $V_{min}$  the stalling speed of the airplane. The experimental points are values measured in abrupt pull-ups, many of which are not otherwise given in this report. With a stalling speed of 53 m. p. h., the theoretical curve passes through the experimental points reasonably well.

LANGLEY MEMORIAL AERONAUTICAL LABORATORY,  
NATIONAL ADVISORY COMMITTEE FOR AERONAUTICS,  
LANGLEY FIELD, VA., May 23, 1930.

## REFERENCES AND BIBLIOGRAPHY

- Reference 1. Reid, H. J. E.: A Study of Airplane Maneuvers with Special Reference to Angular Velocities. N. A. C. A. Technical Report No. 155, 1922.
- Reference 2. Norton, F. H., and Brown, W. G.: Controllability and Maneuverability of Airplanes. N. A. C. A. Technical Report No. 153, 1922.
- Reference 3. Coleman, Donald G.: N. A. C. A. Flight-path-angle and Air-speed Recorder. N. A. C. A. Technical Note No. 233, 1926.
- Reference 4. Reid, H. J. E.: The N. A. C. A. Three-component Accelerometer. N. A. C. A. Technical Note No. 112, 1922.
- Reference 5. Ronan, K. M.: An Instrument for Recording the Position of Airplane Control Surfaces. N. A. C. A. Technical Note No. 154, 1923.
- Reference 6. Crowley, jr., J. W., and Freeman, R. G.: Determination of Turning Characteristics of an Airship by Means of a Camera Obscura. N. A. C. A. Technical Report No. 208, 1925.
- Norton, F. H., and Allen, E. T.: Accelerations in Flight. N. A. C. A. Technical Report No. 99, 1921.
- Francis, H. A.: The Comparison of the Maneuverability of Airplanes by the Use of a Cinematograph Camera. British Reports and Memoranda No. 851, December, 1922.
- Doolittle, J. H.: Accelerations in Flight. N. A. C. A. Technical Report No. 203, 1925.
- Von Baumhauer, A. G.: Photographic Time Studies of Airplane Paths. N. A. C. A. Technical Memorandum No. 345, 1926.
- Raethjen, P., and Knott, H.: Kinetographic Determination of Airplane Flight Characteristics. N. A. C. A. Technical Memorandum No. 409, 1927.

## APPENDIX

Table I

	Low-speed loop	High-speed loop	Push-down abrupt control	Pull-up from dive abrupt control	Pull-up from horizontal flight abrupt control	Pull-up from horizontal flight abrupt control	Pull-up from horizontal flight abrupt control	Right rudder maneuver	Right rudder maneuver	Right barrel-roll	Left barrel-roll	Right spin	First left spin	Second left spin
True air speed at start of maneuver in m. p. h.....	119	147	100	140	142	119	90	105	141	147	140	78	78	79
Maximum longitudinal acceleration, $g$ .....	.50	.70	-.25	1.00	1.80	1.30	.80	.20	.30	1.50	1.42	.45	.60	.50
Time, sec.....	7.50	10.50	5.00	1.00	.60	.55	.45	.20	1.75	.75	.75	8.50	11.00	8.50
Maximum transverse acceleration, $g$ .....								.80	1.50	1.50	4.00	2.75	5.00	
Time, sec.....								1.50	1.50	4.00	2.75	5.00		
Maximum normal acceleration, $g$ .....	2.65	3.75	-2.20	6.65	6.65	4.95	3.05	1.45	1.80	6.90	6.80	2.00	2.40	2.00
Time, sec.....	15.00	11.00	3.00	1.00	.60	.55	.55	1.00	1.00	4.00	4.00	2.80	-3.05	-2.75
Maximum angular velocity, X axis, rad./sec.....										1.70	1.25	8.00	9.25	8.00
Time, sec.....										1.70	1.75	8.75	1.70	1.75
Maximum angular velocity, Y axis, rad./sec.....	.72	.79	-.72	1.45	1.55	1.34	1.05			.65	.70	8.75	11.00	10.00
Time, sec.....	13.50	8.50	1.25	.75	.60	.70	.55			2.30	-1.05	2.55	-2.45	-2.60
Maximum angular velocity, Z axis, rad./sec.....								.95	1.10	1.60	1.30	9.00	11.00	10.80
Time, sec.....								1.25	1.10	6.20	-6.00			
Maximum angular acceleration, X axis, rad./sec. <sup>1</sup> .....										.90	1.00			
Time, sec.....										-3.50	2.70			
Maximum angular acceleration, Y axis, rad./sec. <sup>1</sup> .....	-.80	-.35	-1.80	4.80	3.70	3.95	3.20			1.05	.35			
Time, sec.....	13.75	12.00	.85	.50	.35	.55	.40			2.50	3.00			
Maximum angular acceleration Z axis, rad./sec. <sup>1</sup> .....								1.70	2.00	2.25	2.70			
Time, sec.....								.65	.75	4.80	2.65	3.80	3.95	3.90
Maximum resultant angular velocity, rad./sec.....										1.50	1.50	8.75	11.00	10.00
Time, sec.....												.95	1.40	.80
Maximum resultant angular acceleration, rad./sec. <sup>1</sup> .....												4.75	6.50	5.75
Time, sec.....														
Time to 30° displacement, sec.....			1.60		.55	.70	.75	1.25	1.25					
Time to 45° displacement, sec.....				1.90				1.60	1.50					
Time to 60° displacement, sec.....												1.55	1.55	1.95
Time to 360° displacement, sec.....	18.00	13.50												

<sup>1</sup> Measured with the load carried in this investigation.

### SPECIFICATIONS OF F6C-3 AIRPLANE <sup>1</sup>

Engine.....	Curtiss D-12.	Wing span.....	{ Upper 31.5 ft.
Horsepower.....	425 at 2,300 r. p. m.	Length.....	{ Lower 26 ft.
Full load.....	2,960 lb.	Height.....	22 ft. 7 $\frac{1}{16}$ in.
Weight per sq. ft.....	11.7 lb.	Gap.....	9.25 ft.
Weight per hp.....	6.98 lb.	Angle of incidence.....	4 ft. 5 $\frac{1}{16}$ in.
Maximum speed.....	165 m. p. h.	Stagger.....	-2°.
Service ceiling.....	22,700 ft.	Dihedral.....	38.5 in.
Wing area including ailerons.....	252 sq. ft.	Sweepback.....	{ Upper 0.
Aileron area.....	13.32 sq. ft.	Distance from leading edge lower wing	{ Lower 1 $\frac{1}{2}$ °.
Stabilizer area.....	18.13 sq. ft.	to rudder hinge.....	None.
Elevator area.....	14.78 sq. ft.	Distance forward from leading edge	
Fin area.....	4.67 sq. ft.	lower wing to <i>C. G.</i> <sup>2</sup> .....	13.5 ft.
Rudder area.....	10.8 sq. ft.		
Airfoil section.....	Clark Y.		2.9 in.

<sup>1</sup> From Table of Characteristics, Weights, and Performance of Training, Fighting, and Patrol Airplanes. Bureau of Aeronautics, Navy Department, June, 1927.

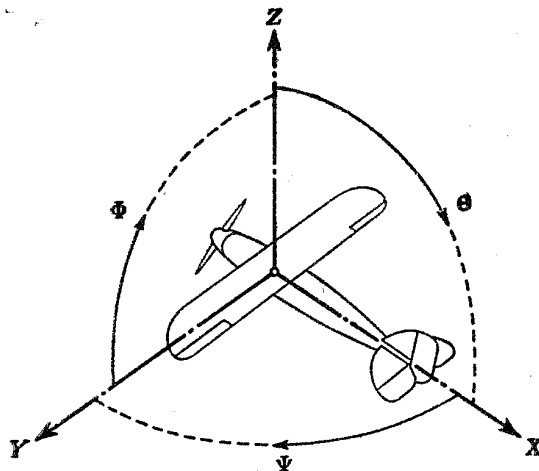

Positive directions of axes and angles (forces and moments) are shown by arrows

Axis		Force (parallel to axis) symbol	Moment about axis			Angle		Velocities	
Designation	Sym- bol		Designa- tion	Sym- bol	Positive direction	Designa- tion	Sym- bol	Linear (compo- nent along axis)	Angular
Longitudinal.....	X	X	rolling.....	L	Y → Z	roll.....	Φ	u	p
Lateral.....	Y	Y	pitching.....	M	Z → X	pitch.....	Θ	v	q
Normal.....	Z	Z	yawing.....	N	X → Y	yaw.....	Ψ	w	r

Absolute coefficients of moment

$$C_L = \frac{L}{q b S} \quad C_M = \frac{M}{q c S} \quad C_N = \frac{N}{q f S}$$

Angle of set of control surface (relative to neu-  
tral position),  $\delta$ . (Indicate surface by proper  
subscript.)

#### 4. PROPELLER SYMBOLS

$D$ , Diameter.  
 $p_e$ , Effective pitch  
 $p_g$ , Mean geometric pitch.  
 $p_s$ , Standard pitch.  
 $p_v$ , Zero thrust.  
 $p_a$ , Zero torque.  
 $p/D$ , Pitch ratio.  
 $V'$ , Inflow velocity.  
 $V_s$ , Slip stream velocity.

$T$ , Thrust.  
 $Q$ , Torque.  
 $P$ , Power.

(If "coefficients" are introduced all  
units used must be consistent.)

$\eta$ , Efficiency =  $T V/P$ .  
 $n$ , Revolutions per sec., r. p. s.  
 $N$ , Revolutions per minute., R. P. M.  
 $\Phi$ , Effective helix angle =  $\tan^{-1} \left( \frac{V}{2\pi r n} \right)$

#### 5. NUMERICAL RELATIONS

1 HP = 76.04 kg/m/sec. = 550 lb./ft./sec.  
 1 kg/m/sec. = 0.01315 HP.  
 1 mi./hr. = 0.44704 m/sec.  
 1 m/sec. = 2.23693 mi./hr.

1 lb. = 0.4535924277 kg.  
 1 kg = 2.2046224 lb.  
 1 mi. = 1609.35 m = 5280 ft.  
 1 m = 3.2808333 ft.