

California Institute of Technology

Active Control of Instabilities in Jet Engines

Final Report for ONR N0001492J1677

John C. Doyle
Caltech 116-81
Pasadena, CA 91125
(818) 395-4808

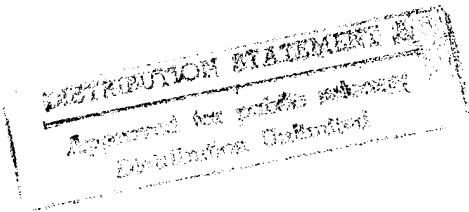

19950925 037

Active Control of Instabilities in Jet Engines

ONR N0001492J1677

Final Report

John Doyle

1 Summary

Advances in several areas of robust control theory and its applications were made during the extension of this program. Our emphasis has been in the development of computable measures of performance robustness for both linear and nonlinear systems, and in the development of computationally sound identification algorithms. In the following paragraphs we briefly discuss the main areas of our program. A detailed description of the results obtained and the future directions to be explored follows. In the detailed description, we will point to the different publications that resulted from this research.

Robust stability and performance analysis with real parametric uncertainty can be naturally formulated as a Structured Singular Value, or μ , problem, where the block structured uncertainty description is allowed to contain both real and complex blocks. It is now well known that computation for the general mixed μ problem is NP complete. Thus, to obtain acceptable computation, we do not attempt to solve the mixed μ problem exactly but rather to obtain good bounds. The key to obtaining a lower bound lies in the fact that the μ problem may be reformulated as a real eigenvalue maximization since for any $Q \in \mathbf{Q}$, $\rho_r(QM) \leq \mu(M)$. The computational complexity of this problem manifests itself in the fact that this function is non-convex and so it is difficult to find the global maximum. Any local maximum, however, is a lower bound to the global maximum. We are currently working on an efficient way to compute a local maximum of the this function using a simple power iteration. We describe this algorithm in more detail in Section 3.

For LTI systems, performance tests are normally posed and answered in the frequency domain, or equivalently on an infinite-time horizon. Although this is something of an artifice for LTI systems, the nature and computation of the tests are simplified as a result. However, when considering non-linear or time-varying systems it is both more natural and computationally convenient to set the performance specification and uncertainty descriptions in the time domain, over a finite horizon. By writing these requirements as quadratic constraints we can answer the analysis question: Is the performance condition met for all the plants in the uncertainty set?, by computing μ of a constant matrix, just as in the LTI infinite horizon case. The size of this μ test is proportional to the length of the horizon, making the computational complexity of the lower and upper bound algorithms an important issue in finite horizon tests. We have exploited the special structure of the matrix associated with the time domain test in order to modify the standard algorithms for the bounds and reduce the growth rate of computation time with the horizon length. This area of our research program is described in Section 4.

Experimental work was also carried out during the development of this project. Advanced control design techniques were applied to multimode stabilization of thermally induced oscillations inside a cavity. through this experimental work we tested the relevance of the different theoretical tools at our reach to practical problems

2 Preliminaries and Notation

The notation we use is as follows. $\mathcal{H}_2, \mathcal{H}_\infty$ denote the Hardy spaces of possibly vector- or matrix-valued functions with analytic continuation on the unit disc, and $\mathcal{L}_2, \mathcal{L}_\infty$ the corresponding Lebesgue spaces of functions square integrable and essentially bounded, respectively, on the unit circle, each with norms $\|\cdot\|_2, \|\cdot\|_\infty$. \mathcal{RH}_∞ and \mathcal{RL}_∞ are the subspaces of \mathcal{H}_∞ and \mathcal{L}_∞ whose elements are rational functions. We represent the integers by \mathbb{Z} , the time shift operator by z^{-1} , and the identity matrix by I , where the dimensions will be assumed to be clear from the context, or will otherwise be stated. The maximum singular value of A is denoted $\bar{\sigma}(A)$, and A^* denotes the complex conjugate transpose.

2.1 Linear Fractional Transformations (LFTs)

We use LFTs to represent uncertain systems as shown in Figure 1.

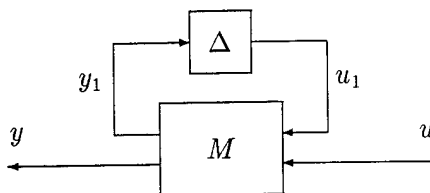

Figure 1: MD/Uncertain System

The frequency/uncertainty structure $\Delta \in \mathbf{\Delta}$ we consider is

$$\mathbf{\Delta} = \{\text{diag} [\delta_1 I_{n_1}, \dots, \delta_S I_{n_S}], \delta_i : \mathcal{L}_2 \rightarrow \mathcal{L}_2\} \quad (1)$$

$$\mathbf{B}\mathbf{\Delta} = \{\Delta \in \mathbf{\Delta} : \|\Delta\|_{\mathcal{L}_2 \rightarrow \mathcal{L}_2} \leq 1\} \quad (2)$$

We assume $M = \begin{bmatrix} A & B \\ C & D \end{bmatrix}$ is a given system realization matrix with A, B and C partitioned compatibly with the block structure $\mathbf{\Delta}$. The input/output mapping for this system is determined by

$$y = (\Delta \star M)u, \quad \Delta \in \mathbf{\Delta}$$

where

$$\Delta \star M = D + C\Delta(I - A\Delta)^{-1}B.$$

For	
<input checked="" type="checkbox"/>	
<input type="checkbox"/>	
<input type="checkbox"/>	
on	
by <i>perletter</i>	
Distribution/	
Availability Codes	
Dist	Avail and/or Special
<i>A-1</i>	

We refer to such system models by the pair (Δ, M) .

2.2 The structured singular value

For any square complex matrix M we denote the complex conjugate transpose by M^* . The largest singular value and the structured singular value are denoted by $\bar{\sigma}(M)$ and $\mu_{\mathcal{K}}(M)$ respectively. The spectral radius is denoted $\rho(M)$ and $\rho_R(M) = \max\{|\lambda| : \lambda \text{ is a real eigenvalue of } M\}$, with $\rho_R(M) = 0$ if M has no real eigenvalues. For any complex vector x , then x^* denotes the complex conjugate transpose, and $|x|$ the Euclidean norm.

The definition of μ is dependent upon the underlying block structure of the uncertainties, which is defined as follows. Given a matrix $M \in \mathbb{C}^{n \times n}$ and three non-negative integers m_r , m_c , and m_C with $m := m_r + m_c + m_C \leq n$, the block structure $\mathcal{K}(m_r, m_c, m_C)$ is an m -tuple of positive integers

$$\mathcal{K} = (k_1, \dots, k_{m_r}, k_{m_r+1}, \dots, k_{m_r+m_c}, k_{m_r+m_c+1}, \dots, k_m) \quad (3)$$

where we require $\sum_{i=1}^m k_i = n$ in order that the dimensions are compatible. This now determines the set of allowable perturbations, namely define

$$X_{\mathcal{K}} = \{ \Delta = \text{block diag}(\delta_1^r I_{k_1}, \dots, \delta_{m_r}^r I_{k_{m_r}}, \delta_1^c I_{k_{m_r+1}}, \dots, \delta_{m_c}^c I_{k_{m_r+m_c}}, \Delta_1^C, \dots, \Delta_{m_C}^C) : \delta_i^r \in \mathbb{R}, \delta_i^c \in \mathbb{C}, \Delta_i^C \in \mathbb{C}^{k_{m_r+m_c+i} \times k_{m_r+m_c+i}} \} \quad (4)$$

Note that $X_{\mathcal{K}} \in \mathbb{C}^{n \times n}$ and that this block structure is sufficiently general to allow for repeated real scalars, repeated complex scalars, and full complex blocks. The purely complex case corresponds to $m_r = 0$. Note also that the full complex blocks need not be square but we restrict them as such for notational convenience.

Definition 1 ([14]) *The structured singular value, $\mu_{\mathcal{K}}(M)$, of a matrix $M \in \mathbb{C}^{n \times n}$ with respect to a block structure $\mathcal{K}(m_r, m_c, m_C)$ is defined as*

$$\mu_{\mathcal{K}}(M) = \left(\min_{\mathbf{B}\Delta \in X_{\mathcal{K}}} \{ \bar{\sigma}(\mathbf{B}\Delta) : \det(I - \mathbf{B}\Delta M) = 0 \} \right)^{-1} \quad (5)$$

with $\mu_{\mathcal{K}}(M) = 0$ if no $\mathbf{B}\Delta \in X_{\mathcal{K}}$ solves $\det(I - \mathbf{B}\Delta M) = 0$.

In order to obtain a lower bound for μ we define the following sets of block diagonal matrices (which are also dependent on the underlying block structure).

$$\mathcal{Q}_{\mathcal{K}} = \{ \mathbf{B}\Delta \in X_{\mathcal{K}} : \delta_i^r \in [-1, 1], \delta_i^{c*} \delta_i^c = 1, \Delta_i^{C*} \Delta_i^C = I_{k_{m_r+m_c+i}} \} \quad (6)$$

$$\mathcal{D}_{\mathcal{K}} = \{ \text{block diag}(e^{j\theta_1} D_1, \dots, e^{j\theta_{m_r}} D_{m_r}, D_{m_r+1}, \dots, D_{m_r+m_c}, d_1 I_{k_{m_r+m_c+1}}, \dots, d_{m_C} I_{k_m}) : \theta_i \in [-\frac{\pi}{2}, \frac{\pi}{2}], 0 < D_i = D_i^* \in \mathbb{C}^{k_i \times k_i}, 0 < d_i \in \mathbb{R} \} \quad (7)$$

3 Improved μ Lower Bound Computation

Robust stability and performance analysis with real parametric uncertainty can be naturally formulated as a Structured Singular Value, or μ , problem, where the block structured uncertainty description is allowed to contain both real and complex blocks. For more engineering motivation of the use of these approaches, see [1, 16] and the references therein.

It is now well known that computation for the general mixed μ problem is NP complete [52, 13, 9]. It is still a fundamental open question in the theory of computational complexity to determine the exact consequences of a problem being NP complete, and we refer the reader to [21] for an in depth treatment of the subject. However, it is generally accepted that a problem being NP complete means that it cannot be computed in polynomial time in the worst case. It is important to note that being NP complete is a property of the problem itself, not any particular algorithm. The fact that the mixed μ problem is NP complete strongly suggests that given *any* algorithm to compute μ , there will be problems for which the algorithm cannot find the answer in polynomial time. Roughly speaking, this means that mixed μ cannot be computed exactly in the worst case without entirely unacceptable growth in computation cost with problem size. For all practical purposes even moderately large examples of such problems are computationally intractable. To obtain acceptable computation, we do not attempt to solve the mixed μ problem exactly but rather to obtain good bounds. Furthermore, [13] suggests that even approximate methods are also NP complete, so we will not expect good worst case behavior but rather aim for good typical behavior.

The key to obtaining a lower bound lies in the fact that the μ problem may be reformulated as a real eigenvalue maximization [66].

$$\max_{Q \in \mathbf{Q}} \rho_r(QM) = \mu(M) \quad (8)$$

Here ρ_r is the real spectral radius, and \mathbf{Q} is a set of matrices with appropriate structure. This immediately gives us a theoretical lower bound since we have that for any $Q \in \mathbf{Q}$, $\rho_r(QM) \leq \mu(M)$. The computational complexity of this problem manifests itself in the fact that this function is non-convex and so it is difficult to find the global maximum. Any local maximum, however, is a lower bound to the global maximum.

The idea then is to find an efficient way to compute a local maximum of the function $\rho_r(QM)$ over $Q \in \mathbf{Q}$. It turns out that this can be done by means of a simple power iteration. The iteration scheme usually converges fairly rapidly and each iteration of the scheme is very cheap, requiring only such operations as matrix-vector multiplications and vector inner products.

Unfortunately the lower bound power iteration is not always guaranteed to converge. Although one can still obtain a lower bound in this case, it may no longer correspond to a local maximum of the real spectral radius, and so the bound may be poor. While Branch and Bound techniques are an effective way of obtaining improved bounds, results in [41] strongly suggest that the quality of the upper and lower bounds for μ are critical to the performance of any Branch and Bound scheme to refine them. This means that any improvement in the lower (or upper) bound performance is highly desirable, whether one wishes to use the bounds

directly, or as part of a Branch and Bound scheme.

There is additional motivation for further development of the lower bound computation: there are important problems for which computation will require generalizations of the current lower bound algorithm and these generalizations are expected to be more difficult in the sense that it will be harder to converge to local maximums. One such problem is the Model Validation problem, where we wish to determine whether measured data (time histories) are consistent with a given robust control model with pre specified bounds on uncertainty operators and unknown noise. Another is the robust control ID problem. Here, we wish to determine parameters that best fit measured data in that they select a robust control model with (in some sense) minimal uncertainty or noise. Both of these problems are distinguished by the presence of known signals. Problems of this nature in general require an extension of the current lower bound computation. Note that the lower bound algorithm finds solutions to the associated loop equations and for the Model Validation problem and the ID problem these solutions include noise signals and/or parameters of the model.

The increased difficulties encountered in the mixed μ problem stem from a simple fact. In the complex only case, the real spectral radius maximization is equivalent to a spectral radius maximization. That is, if we maximize the spectral radius, then we can easily create a real eigenvalue equal to the spectral radius. Hence we may use an algorithm that generalizes the Rayleigh-Ritz method of finding the spectral radius. This is not the case in the general mixed μ problem. Here we wish to maximize the largest real eigenvalue even when the spectral radius is much larger. Consequently local maxima are not generally stable equilibria of the standard power iteration. This is because errors with a component in the direction of the eigenvector corresponding to the eigenvalue that achieves the spectral radius are amplified. A consequence of this is that the lower bound algorithm, as implemented in the μ -tools toolbox, fails to find a local maximum on a significant number of problems.

In [61] it is demonstrated that there is potential for substantial improvement over the standard algorithm. The present goal, and the focus of the lower bound work over the past year, is to develop an efficient algorithm that retains the performance of the current algorithm when this is satisfactory, and, when is it not, find a (large) local maximum as efficiently as possible.

One aspect of this research is the investigation and development of a shift and inverse algorithm. This is a generalization of shift and inverse algorithms for finding eigenvalues and eigenvectors. Observe that if $\lambda x = Mx$, then $(\lambda - \beta)x = (M - \beta I)x$ and $(\lambda - \beta)^{-1}x = (M - \beta I)^{-1}x$. If β is close enough to λ , then $|(\lambda - \beta)^{-1}|$ is equal to the spectral radius of $(M - \beta I)^{-1}$ and a power algorithm would tend to find the eigenvalue $(\lambda - \beta)^{-1}$ which is equivalent to finding the eigenvalue λ of M .

This technique has been used for the mixed μ lower bound real eigenvalue maximization problem. The idea is to chase an eigenvalue to a local maximum: we shift-and-inverse iterate to find an eigenvalue of $M\Delta$, then we update Δ (this is moving in the domain of optimization) based on the eigenvectors and repeat. The difficulty with this approach is that Δ must change slowly so that the next shift is close to the eigenvalue we are chasing. This necessitates many steps and the steps are not as cheap as we would like (the cost grows with the cube of the

size of M), so this method is less than ideal.

Another approach is based on the fact that the optimum over the parameters jointly is also an optimum over a subset of the parameters when the complement of the subset is held fixed at their optimal values. Now the optimum over the complex variables is quick and easy: this is the standard power algorithm on a strictly complex problem. The optimization over the real parameters may be approached with conventional optimization techniques as all the real blocks are scalar times identity blocks and thus there are relatively few real parameters. The drawback to this problem is that the conversion between the two optimization problems is not cheap, and conventional optimization techniques still may require many steps.

While the current implementation of these ideas results in an algorithm that is much better than the standard algorithm in that it finds much better solutions to most of the difficult problems reasonably quickly, we believe there is room for further substantial improvement. These improvements would come not only from refinements to the algorithms described above, but also from a careful combination of these algorithms and the standard power algorithm.

4 Finite Time Horizon Robust Performance Analysis

4.1 Introduction

For LTI systems, it is convenient to pose performance tests over an infinite horizon. This artifice, in this particular subset of systems, simplifies rather than complicates the nature and computation of the tests. However, if we want to work with non-linear or time-varying systems it is more natural, and computationally convenient, to set the performance specification and uncertainty descriptions in the time domain, over a finite horizon. As in the LTI infinite horizon case, when these requirements are written as quadratic constraints we can answer the analysis question: Is the performance condition met for all the plants in the uncertainty set?, by computing the structured singular value μ of a constant matrix. The size of the μ test required grows linearly with the length of the horizon, making the computational complexity of the lower and upper bound algorithms an important issue in finite horizon tests. By exploiting the special structure of the matrix associated with the time domain test, we can modify the standard algorithms for the bounds, to reduce the growth rate of computation time with the horizon length.

When the finite time tests are applied to LTI systems over increasing horizons, we would expect to recover the infinite horizon results. The connection between the exact tests is a previously established property of the structured singular value. By using losslessness of the S-Procedure theorem (see [37] and the references therein) we have extended these connections to the upper bounds of the finite time and frequency domain tests. We expect these connections to shed new light on the nature of both tests.

One of the most exciting applications of this theory is the analysis of non-linear systems. We can use the analysis tool for finite horizon linear time varying (FHLTV) systems as one step in an iterative procedure for analysis of non-linear systems along trajectories. This procedure, which alternates simulation of the nonlinear system, and linearization around a

perturbed trajectory can locally find worst case noise signals. Ongoing research is dedicated to the development of efficient and numerically sound algorithms for carrying out this procedure.

4.2 Problem Setup

4.2.1 Linear Time Varying Systems in Finite Horizon

LTI systems are normally described as transfer functions, namely a map from l_2 into l_2 . However, in order to derive computable tests we have to describe them in terms of constant matrices. This can be done either in state space, by incorporating the delay operator in the uncertainty, or in the frequency domain, by doing a search over frequency. The analysis at each frequency point reduces to a constant matrix problem. None of these approaches extends naturally to time varying systems considered over a finite time horizon. However, a FHLTV system can be represented as a finite dimensional map (i.e. a constant matrix) by mapping the time axis into a spatial axis. To illustrate this point let's consider a discrete time linear time varying system, over a time horizon of k steps. The system is described by the equations:

$$\begin{aligned} x_{i+1} &= A(i)x_i + B(i)u_i \\ y_i &= C(i)x_i + D(i)u_i \quad i = 0 \dots k-1 \end{aligned} \quad (9)$$

These equations can be rewritten as:

$$\begin{pmatrix} x_{i+1} \\ y_i \end{pmatrix} = M(i) \begin{pmatrix} x_i \\ u_i \end{pmatrix} \quad i = 0 \dots k-1 \quad (10)$$

We can define a map from the initial state and the time history of the inputs (from $t = 0$ to $t = k-1$), to the final state and the time history of the outputs (from $t = 0$ to $t = k-1$). We denote this mapping with the symbol $M_{[k]}$. (See Figure 2.) The system is now represented by a single constant matrix $M_{[k]}$, over which we can write our performance bounds. Note that the dimensions of the matrix $M_{[k]}$ grow linearly with the length of the time horizon. This requires that a strong emphasis be put on the development of efficient algorithms for the computation of the stability tests.

4.2.2 Time Domain Uncertainty - Performance Specifications

In finite time horizon problems, performance is the only relevant concept, since stability is just an artifact of infinite time. For this work we consider performance and uncertainty conditions which can be written as quadratic constraints in the variable:

$$z = (x_0 \ u_0 \ \dots \ u_{k-1} \ x_k \ y_0 \ \dots \ y_{k-1})^t$$

The uncertainty and performance constraints have the form:

$$\sigma_i(z) > 0 \quad (11)$$

Where $i = 0$ for the performance constraint, and $i = 1 \dots n$ for the uncertainty constraints. In defining these QCs we use the following conventions:

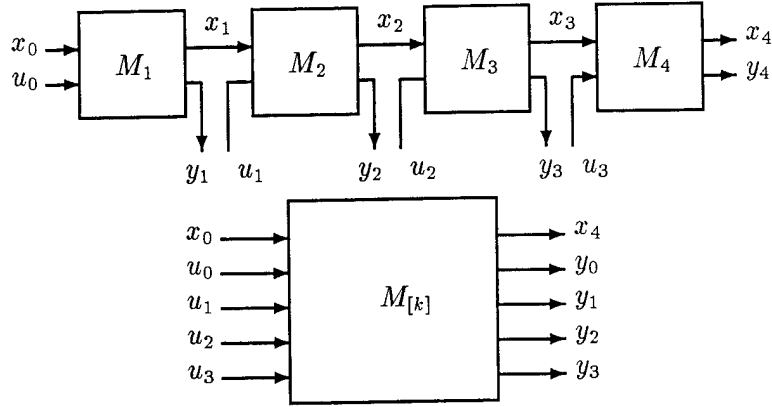

Figure 2: Finite time horizon system as a constant matrix transformation

- When the QC describes an uncertainty condition, $\sigma_i(z) > 0$ implies that there exists an instance of the uncertainty with the desired properties that can account for the data in z .
- When the QC describes the performance specification, $\sigma_0(z) > 0$ implies that the data does not meet the performance required.

As seen in [60] and [48], there is a Δ -structure associated with this uncertainty-performance description. We give two examples of how to convert from one representation to the other.

The performance quadratic constraint:

$$\sum_{i=0}^{k-1} \|u(i)\|^2 + \|x_0\|^2 > \sum_{i=1}^k \|y(i)\|^2 + \|x_k\|^2 \quad (12)$$

is met if the total energy at the output is smaller than the total energy at the input. The corresponding Δ structure for this QC is a map from the final state and the full time history of the output to the initial state and the full time history of the input as shown in Figure 3

If the uncertainty we wish to describe is a bounded varying gain, we use the QCs:

$$\|y(i)\|^2 - \|u(i)\|^2 > 0 \quad 0 < i < k - 1 \quad (13)$$

The associated uncertainty structure is block diagonal, as shown in Figure 4.

4.2.3 Time Domain μ

Using the setup described in the preceding section, it is easy to see that the time domain performance problem can be recast as a standard μ problem on the matrix $M_{[k]}$, with respect

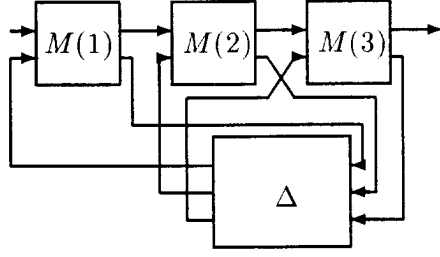

Figure 3: Total output energy to total input energy performance

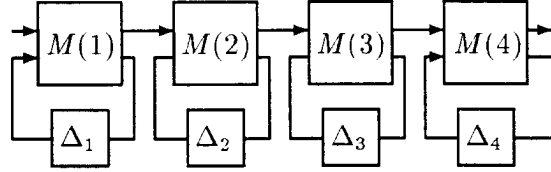

Figure 4: Instant by instant output energy to input energy uncertainty

to a block structure $[\Delta_u, \Delta_p]$ that can be derived from the preceding definitions. Therefore the performance specifications are met robustly whenever the following condition holds:

$$\mu_{[\Delta_u, \Delta_p]}(M[k]) < 1$$

where μ is the standard structured singular value as defined for example in [42].

Thus we have the following definition:

Definition 2 *Time domain μ* Given a system of the form (10), observed over a time horizon of k steps, and uncertainty specifications given by the quadratic constraints σ_i , $i = 0 \dots n$ then:

$$td\mu_{\{\sigma_i\}}(M(\cdot), k) := \mu_{\Delta_u, \Delta_p}(M[k])$$

4.3 Necessary and Sufficient Conditions

4.3.1 A Necessary condition for performance

If we scale the variable z to z_λ , i.e.,

$$z = (x_0 \ u_0 \ \dots \ u_{k-1} \ \lambda x_k \ \lambda y_0 \ \dots \ \lambda y_{k-1})^t$$

and write the performance-uncertainty QCs in z_λ , we will be relaxing the requirements: the bigger λ is the easier it is for the system to meet these requirements. Let λ_{\max} be the maximum value of λ for which the conditions are not met. A necessary condition for performance is $\lambda_{\max} < 1$. As shown in [44] $\lambda_{\max} = \max \rho(QM[k])$, where Q is unitary and has the same structure as $[\Delta_u, \Delta_p]$. We can not in general compute this value, but we can compute local maxima $\hat{\lambda}$ of $\rho(QM[k])$ along with the signals $(x_0 \ u_0 \ \dots \ u_{k-1})^t$ for which the conditions $\sigma_i(z_{\hat{\lambda}})$

fail. This not only gives us a way to compute a necessary condition for performance (v.z. $\hat{\lambda} < 1$), but it also gives us a way of finding worst case signals for the system. This fact will be important when applying this theory to the analysis of nonlinear systems (See Section 4.5).

Computationally sound algorithms have been developed (see [66] and references therein) to compute a lower bound for the maximum over Q of the spectral radius of QM . In order to apply this algorithm to our problem some modifications were made in order to exploit the structure of the matrix $M_{[k]}$ and avoid quadratic growth in computation time with the length of the horizon ([60]).

4.3.2 Sufficient conditions for performance

As with the necessary condition, we have derived a sufficient condition for robust performance from the constant matrix μ problem described in section 4.2.3.

Definition 3 *Time domain upper bound*

$$tdub_{\{\sigma_i\}}(M(\cdot), k) = ub_{[\Delta_u, \Delta_p]}(M_{[k]})$$

where ub denotes the standard μ upper bound.

It is immediate that $tdub_{\{\sigma_i\}}(M(\cdot), k) < 1$ is a sufficient condition for robust performance.

The same computational complexity problems arising in the lower bound arise in the computation of the upper bound. However, it is not as straightforward to use the structure in the matrix $M_{[k]}$ to reduce the growth of the computation time, when using current state of the art optimization algorithms for LMIs.

Using gradient search, we can develop an algorithm that is slower on small problems when compared to the LMI methods, but whose computation time doesn't degrade as much with the number of time samples. However our tests of this algorithm are still preliminary and more extensive experimentation and further research is being completed in this area.

4.4 Connections to the frequency domain tests

Assuming the system under consideration is LTI, the uncertainty description is repeated at each time instant and the performance condition is given as a full block mapping the final state to the initial state, we have developed connections between the time domain tests and the corresponding frequency domain tests. The following two theorems give an idea of the nature of this relationship.

Theorem 1 [44] *Given a system M an uncertainty structure Δ_u , and $\epsilon > 0$, then there exists $K > 0$ such that for all $k > K$, $td\mu(M(\cdot), k) < 1 + \epsilon$, if and only if $\mu_{\Delta}(M) < 1$*

When the system is a constant matrix, we use results on the losslessness of the S-procedure ([37], [6], [48]) to generalize the preceding result to the upper bounds in the frequency and time domains, respectively:

Theorem 2 Given a system M an uncertainty structure set Δ_u , and $\epsilon > 0$, then there exists $K > 0$ such that for all $k > K$, $tdub(M(\cdot), k) < 1 + \epsilon$ if only if $fdub_{\Delta_u}(M) < 1$

From these connections we expect to derive a better understanding of the nature of the frequency domain tests for LTI systems, especially in view of the results in [49] and [50].

4.5 Application to Non-Linear Systems

An exciting application of this theory is as part of an iterative algorithm to analyze the performance of discrete time non-linear systems. The state of the art for non-linear performance analysis is extensive simulation under different perturbations and uncertainty instances. We propose an iterative algorithm that can locally find worst case perturbations and uncertainty. This algorithm can be used to reduce the number of simulations needed in the analysis of the plant.

4.5.1 An iterative analysis tool

We consider a discrete time non-linear system described by the equations:

$$\begin{aligned} x_{i+1} &= A(x_i)x_i + B_1(x_i)u_i + B_2(x_i)w_i \\ y_i &= C(x_i)x_i + D_1(x_i)u_i + D_2(x_i)w_i \quad i = 1 \dots k \end{aligned} \quad (14)$$

We analyze this system along the trajectory generated by a previously specified input u . Our objective is to find the norm bounded disturbance signal w that locally maximizes the distance from the perturbed to the nominal trajectory measured in the 2-norm.

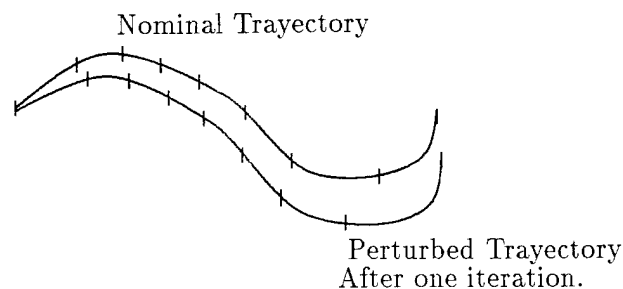

Figure 5: First step in Simulation

To start the procedure we simulate the nonlinear system along the nominal input, in the absence of noise. We then consider perturbations of the system along this trajectory caused by the disturbance w .

$$\begin{aligned} x_{i+1}^{[n]} + x_{i+1}^{[p]} &= A(x_i)x_i + B_1(x_i)u_i + B_2(x_i)w_i \\ y_i^{[n]} + y_i^{[p]} &= C(x_i)x_i + D_1(x_i)u_i + D_2(x_i)w_i \quad i = 1 \dots k \end{aligned} \quad (15)$$

where we have decomposed x and y into a nominal and perturbed component. The perturbations around the nominal will verify the following uncertain time varying linear equations:

$$\begin{pmatrix} y_1^{[p]} \\ \vdots \\ y_k^{[p]} \end{pmatrix} = \left(\Delta \star \begin{bmatrix} P_{11} & P_{12} \\ P_{21} & P_{22} \end{bmatrix} \right) \begin{pmatrix} w_1 \\ \vdots \\ w_k \end{pmatrix} \quad (16)$$

These equations have the form described in the preceding sections. We can thus use the $td\mu$ lower bound algorithms to obtain worst case perturbations for this system. We scale this perturbation to the predetermined noise size, and simulate the original non-linear system. Denote by w_0 the time history of the noise signal, w , and $y_0^{[p]}$ the time history of the perturbation around the nominal trajectory.

We can repeat the previous linearization around the perturbed trajectory. If we denote by $w + w_0$ and $y^{[p]} + y_0^{[p]}$ the total noise and total distance to the nominal, the equations for the new linearization are:

$$y^{[p]} = \left(\Delta \star \begin{bmatrix} P_{11} & P_{12} \\ P_{21} & P_{22} \end{bmatrix} \right) w \quad (17)$$

Our objective is now to find the perturbation w that maximizes the gain $\frac{\|y^{[p]} + y_0^{[p]}\|}{\|w + w_0\|}$, while fixing the size of the total noise $w + w_0$ and of the uncertainty. Although this appears to be of a somewhat different nature than the test in 16, we can rewrite it to put it in the same setup as before. This is made clear by the block diagram in Figure 6.

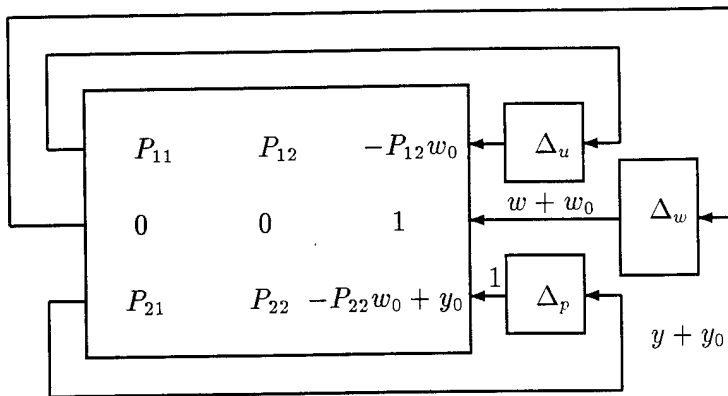

Figure 6: Setup for the second step in the simulation

In this new problem the sizes of Δ_u and Δ_w are fixed and we are trying to minimize the size of Δ_p .

After the second step we simulate the nonlinear system with the new perturbation. We check at this point if the linearization in the previous step is still valid in the new trajectory. If it is, we stop the algorithm; otherwise we repeat the second step.

4.5.2 Computational Aspects

Although most of the theoretical issues in the development of this algorithm have been completed, more research is needed to fully understand the behavior of the practical algorithms. The algorithms are of similar nature to the ones used in the usual performance analysis tests. However they are applied to a different set of matrices. We still do not have enough knowledge of the convergence characteristics of the algorithms over this new set. Our current efforts are in this direction.

5 Model Validation and System Identification

5.1 Introduction

The basic element of any quantitative approach to scientific and technological problems is a mathematical model. These models are typically obtained using some combination of first principles and identification from experimental data. First principles models build on scientific knowledge which is itself often the consequence of extensive experimentation. The most useful models would in principle arise from a judicious combination of first principles and system identification, with the measure of a model's usefulness being highly context dependent. In general, we might start with a model with some a priori structure (here we could use some first principles knowledge), and which includes some description of the a priori uncertainty (parameters, disturbances, etc.). After performing an experiment, we pose the mathematical problem of finding values of the uncertainty that fit our data.

An extensive field of research has been built in pursuing the answer to this problem; a standard reference is [28]. A canonical example of the methods of standard system identification, is the fitting of a parametric model by using prediction error methods (PEMs). We assume the following model structure,

$$y = G(\lambda, \theta)u + H(\lambda, \theta)n \quad (18)$$

where λ is the shift operator, θ is a vector of parameters, G and H are discrete time systems, and n is assumed to be noise. Given data for u, y , these methods attempt to find values of θ, n which explain the data; since many solutions typically exist, the standard approach is to choose the solution which minimizes some norm of n .

A related problem is the *model validation* question: given a model and data, does the model explain the data? In the previous example, the typical situation is that values of θ have already been chosen, and we wish to determine whether the model explains a set of data with a "plausible" instance of n . Although these two questions appear to be different from the point of view of classical system identification, if we consider the various forms of uncertainty in an equal footing, this distinction disappears, as will now be explained. The basic mathematical question that needs to be answered is the following:

Q: *Given an uncertain model and experimental data, do there exist values of the uncertainty such that the model fits the data?*

In the above example of system identification, the uncertainty used to explain the data is made up of real parameters and a disturbance, whereas in the model validation example only the disturbance is used; but the essence is the same, and one could think of including other descriptions of uncertainty (e.g. unmodeled dynamics) into the problem. In PEM, the only feature which is added to the previous question, is an optimization: among the possible combinations of parameters and noise that give an affirmative answer to **Q**, the minimization of the noise is desired. Also, parameters and noise are treated in the PEMs in a non-symmetric way: the parameter values obtained will be considered fixed in the resulting model, but not the actual values of the noise.

While this may be a reasonable procedure under many circumstances, it is not objectively clear that it is the best approach: conceivably, one could prefer a final model where some parametric uncertainty is left. These choices are up to the user, and more choices will arise as we include other sources of uncertainty. Also, we can imagine multiple experiments, where some of the uncertainty is fixed to have a common value across experiments, whereas other parts (e.g., noise, parametric variations due to changes in experimental conditions, unmodeled dynamics), is allowed to vary from one experiment to another.

Therefore, a general methodology for model validation and system identification should provide computational tools for answering the above general question **Q** for very rich uncertainty structures, including noise, unmodeled dynamics, and parameters. Even the parameters may have a variety of allowable variations across experiments or across time within one experiment. On top of this basic tool, one can think of superimposing other criteria to select the final model, or to perform the validation question iteratively on various structures and sizes of parameters to select the final model. We will concentrate in what follows on mathematical and computational machinery to address **Q**.

5.2 Model validation/ID in an LFT setting

5.2.1 An input-output approach

When the uncertainty entering a model is described in an LFT manner, techniques for robustness analysis can be adapted to answer the general model validation question **Q**. We begin by reviewing briefly the approach given in [40], to address this question, which involves a generalization of the structured singular value μ .

A model with incorporated uncertainty is illustrated in Fig. 7. For simplicity, there are no dynamics in this model, all the signals in the diagram are constant vectors, and P, W_n, Δ constant matrices. We can think of identifying a static map; also, in the case of system identification, there are ways of rewriting the equations with no explicit time horizon; this will be mentioned later.

The model, P , is given, as is the perturbation structure for Δ . The signals d and n represent unknown disturbances and noise respectively. The model carries with it, assumptions on the size of the unknown components. In particular it is assumed that $\Delta \in \mathbf{B}\Delta$, $\|d\| \leq 1$, and $\|n\| \leq 1$.

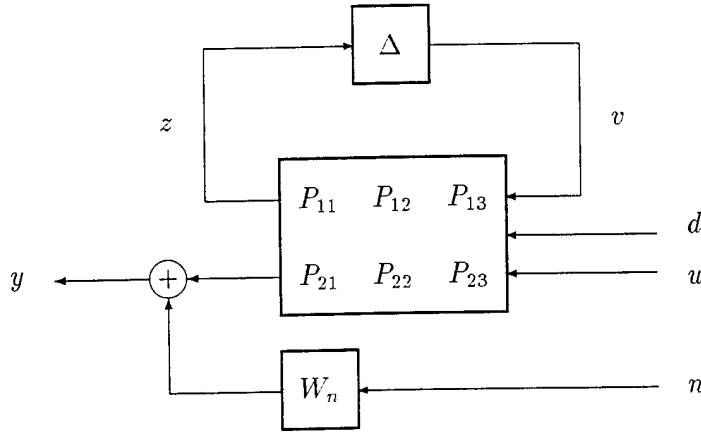

Figure 7: Block diagram of the model validation problem

The LFT form of the input-output description of this system is,

$$y + W_n n = \Delta \star P \begin{bmatrix} d \\ u \end{bmatrix}$$

The perturbation, Δ , has a prescribed block structure and norm bound: $\Delta \in \mathbf{B}\Delta$. We will assume that the models under consideration are well posed for all $\Delta \in \mathbf{B}\Delta$. Equivalently, $\mu(P_{11}) < 1$. This ensures that the inverse in the fractional equations is always well defined.

An input-output experiment has been run and a measured datum (y, u) is available. The model validation problem is to determine whether there is an element of the model set, which includes unknown perturbations and unknown noise and disturbance signals, such that the observed datum can be produced by the model. This is a necessary condition for the model to be able to describe the system. In the work presented here we will consider only the case where P and Δ are constant, complex valued matrices. Application to the more useful problem involving dynamic systems is given in [57]. The problem can be stated as follows.

Problem 3 (Model Validation) *Assume that $\mu(P_{11}) < 1$. Does there exist a $\Delta \in \mathbf{B}\Delta$, and signals d and n , satisfying $\|d\| \leq 1$ and $\|n\| \leq 1$, such that*

$$y + W_n n = \Delta \star P \begin{bmatrix} d \\ u \end{bmatrix}$$

Any (Δ, d, n) satisfying these conditions will be referred to as admissible. We will assume that W_n is invertible. This means that every measured output, y , is modeled as having some non-zero noise added to it. Again this is reasonable in any physically motivated problem. Note that if $y - P_{23}u = 0$ then the model validation problem is solved trivially. Assuming that this is not the case, the problem can be reduced to a generalized μ test:

Theorem 4 *There exists a $\Delta \in \mathbf{B}\Delta$, and signals d and n , with $\|d\| \leq 1$ and $\|n\| \leq 1$ satisfying*

$$y + W_n n = F_u(P, \Delta) \begin{bmatrix} d \\ u \end{bmatrix}$$

iff $\mu_g(\tilde{P}) \geq 1$.

In the theorem,

$$\tilde{P} = \begin{bmatrix} P_{11} & P_{12} & P_{13}u \\ 0 & 0 & 1 \\ W_n^{-1}P_{21} & W_n^{-1}P_{22} & W_n^{-1}(P_{23}u - y) \end{bmatrix}$$

is a matrix obtained from the model and the data, and $\mu_g(\cdot)$ is a matrix function which generalizes μ . We refer to [40] for the definition of this function and details of the proof of these results.

5.2.2 Model Validation as Behavioral analysis

A remarkable recent development [15] is that the behavioral robustness analysis framework provides an alternative (equivalent) way of posing this model validation question; since this framework is more closely related to the rest of our program we will concentrate in what follows on this new formulation.

Figure 8 shows a generic input-output Model Validation structure, slightly more general than Figure 7. z is a vector of unknown inputs, constrained by $\|z\| \leq 1$, which could encompass d and n in the previous structure. Δ varies in $\mathbf{B}\Delta$, and we assume $\mu(P_{11}) < 1$ as before. u, y are the measured inputs and outputs, (we assume that $y \neq P_{22}u$). The model validation question is, once more, to find values of (Δ, z) which account for u, y .

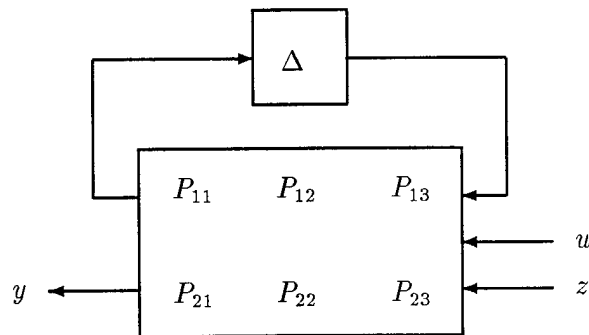

Figure 8: A standard input-output model validation setup.

In figure 9, the same equations are represented in output nulling form (see [12]). Combining u and y into a vector w (which includes all the observed data) gives the behavioral representation of figure 10. Note that the input-output partition has been eliminated from

the model; in fact, it could very well be that we wish to validate some model based on observations of a system where this distinction is not available to us, and we use a behavioral model as a starting point. We can now incorporate the data into the matrix in a similar manner to what was done in the input output setting, leading to figure 11. Up to this point, no special advantage was obtained by using the behavioral equations.

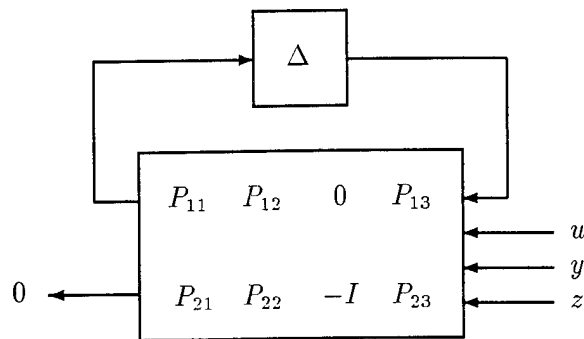

Figure 9: Reduction to behavioral form

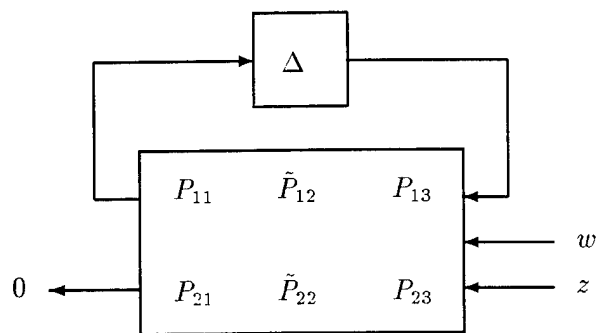

Figure 10: A standard behavioral model validation setup.

We have an analysis problem involving a constant matrix, but we must deal with the norm constraint on the disturbance z . At this point the behavioral framework gives us the possibility of expressing this constraint in GON form, in the same way as in the case of IQCs (see [48]). We enforce the constraint $\|z\| \leq 1$ by adding two equations to the diagram. (See Figure 12.) The first, $p = \Delta_p 1$, introduces a variable, p , used on the output side of a norm bounded block. The second ensures that $z = p$. With $\|\Delta_p\| \leq 1$, we now have that $\|z\| \leq 1$. In Figure 12 the global GON representation for the model validation problem is depicted. The fact that one signal is constrained to be 1 is irrelevant, since everything can be normalized by linearity. Therefore the model validation question reduces to the analysis

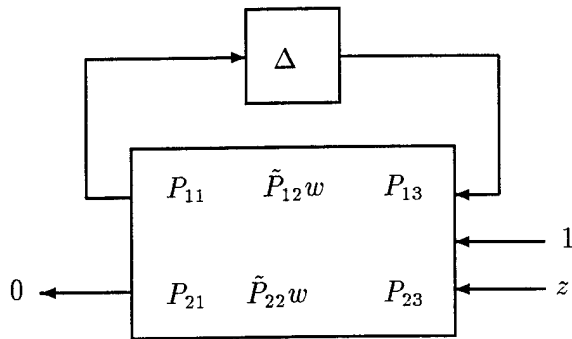

Figure 11: The model validation setup with no signal constraints.

question “do there exist nontrivial signals satisfying these GON equations for $\Delta \in \mathbf{B}\Delta$?”, which can be addressed using the machinery of [48]. In this case the D matrix of the GON representation is tall, and will be full column rank unless $\tilde{P}_{22}w = 0$, which is a trivial case because the nominal model satisfies the data. Therefore it can be reduced to the question $\text{Ker} \begin{bmatrix} I_n - \Delta A \\ C \end{bmatrix} = 0 \forall \Delta \in \mathbf{B}\Delta$.

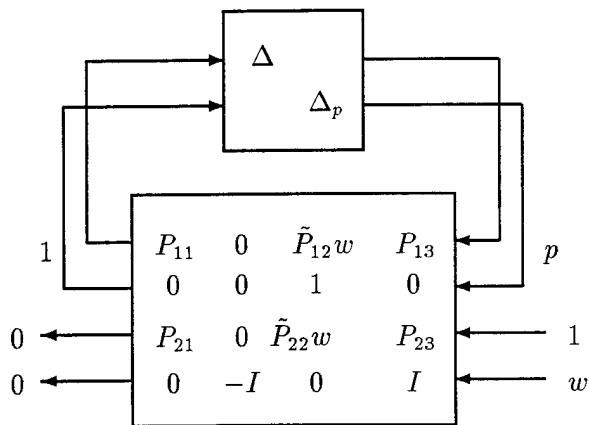

Figure 12: Model validation as an analysis problem

The LMI developed in [48] will be a sufficient condition for invalidating the model: no signals exist and therefore the data cannot be explained.

Necessary conditions, generalizing the lower bounds for μ , are yet to be developed and are an important element to be addressed in this program. In the case of the lower bounds for μ , the available algorithms search for a destabilizing perturbation; this would correspond in our

case to a value of Δ such that the previous kernel is nontrivial. If such a value is found in the unit ball, it would give (together with the disturbance signals obtained from the kernel) the values of uncertainty which account for the data.

This last point has an important implication: an extension of the μ lower bound algorithms not only contributes to the model validation problem, but also to system identification question: if some of the uncertainty in the Δ structure is real parametric, it would give the values of the parameters which are used to fit the data. This reinforces the argument that system identification and model validation are essentially equivalent problems.

5.2.3 Incorporating time domain data and dynamical models

The previous section was based on static representations for models and data, with no explicit time variable. *System Identification*, on the other hand, deals with dynamical models and observations of a given variable across time. However, since the horizon is finite it is a conceptually simple task to transform the time axis into a spatial axis, by writing vectors with the whole time history of a given variable, and large matrices which include the equations. More details of this procedure can be found in Section 4 and references therein. This, in principle transforms the dynamic problem to the static situation described before. However, computational difficulties arise from building these large problems, and efficiency considerations are dominant.

An alternative approach for LTI systems is to pose model validation problems in the frequency domain; this requires the availability of frequency domain data in the form of signal values at a number of frequency points. Since this is not usually available, a previous estimation of a number of frequency points from the time-domain data is required, and gives the results only approximate value. From this point onwards the problem can also be turned into a static one in the same way as before.

6 Experimental Work: Active Control of Combustion Instabilities

6.1 Introduction

Oscillations excited by heat release mechanisms inside combustion chambers are one of the factors affecting the performance of a diverse group of propulsion systems. In practice, instabilities are avoided by changes in the design of the combustion chamber, or by the use of passive stabilization at the expense of the efficiency of the combustion process.

Although the idea of actively controlling these instabilities has been proposed previously ([10], [19],[27]L), it has never been implemented in a practical system. Recent research efforts have applied the technique to small scale experimental combustors. However, this efforts are all restricted to controlling one mode of oscillation. The successful implementation of active instability suppression in cavities with complex geometries requires the ability to control several closely spaced resonance modes.

We concentrate our effort on the design of multi-mode controllers for oscillations in a Rijke tube. To achieve this we will use modern optimal controller design techniques to modify the linear acoustic dynamics of the tube.

6.2 Experimental Setup

The Rijke tube is one of the simplest experimental manifestations of thermally driven acoustic oscillations. It consists of a cylindrical tube fitted with a heating element. The heater is placed one quarter of the way along the tube, and its effective cross section covers most of the section of the tube. The tube is held horizontally, and a fan maintains an average air flow through it.

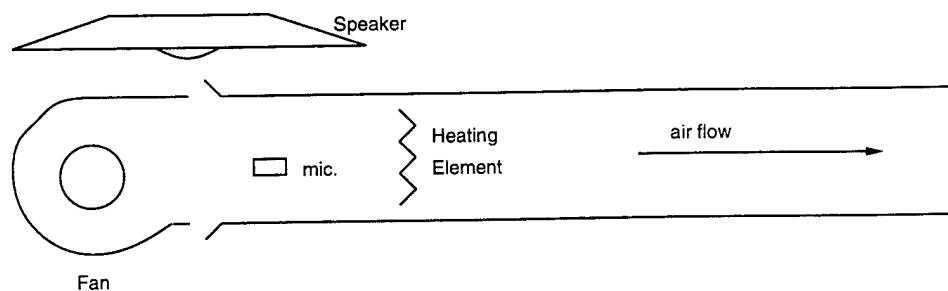

Figure 13: Description of the Experimental setup

A loudspeaker is used as actuator. It is placed with its main plane parallel to the tube axis, and its center aligned with the intake opening of the tube. The sensor used is a miniature, FET based microphone placed inside the tube. Both the sensor and the actuator are placed at the intake end of the tube to make controller design easier. Figure 13 gives a schematic diagram of the experimental setup.

Controllers are implemented using a real time computer. Analog to digital and digital to analog converters in the real time system are clocked at 10 kHz, and all sampled signals are low pass filtered at 3 kHz before sampling.

Both the mean air speed and mean heat input can be varied to allow for controller robustness measurements. Also, the tube has been built with an emphasis on the use of standard parts. This makes results obtained easier to reproduce and verify and will also help in establishing a meaningful benchmark for controller design techniques.

6.3 Proposed Model

For controller design purposes we assume that the acoustic dynamics of the tube are linear at the noise levels present. Three energy sources drive the pressure oscillations inside the tube: noise from the environment, the heat release at the heating element and the speaker. The heat release is a function of the acoustic speed at the position of the heating element. Since the heat release does not depend on the direction of the air flow, this driving is nonlinear.

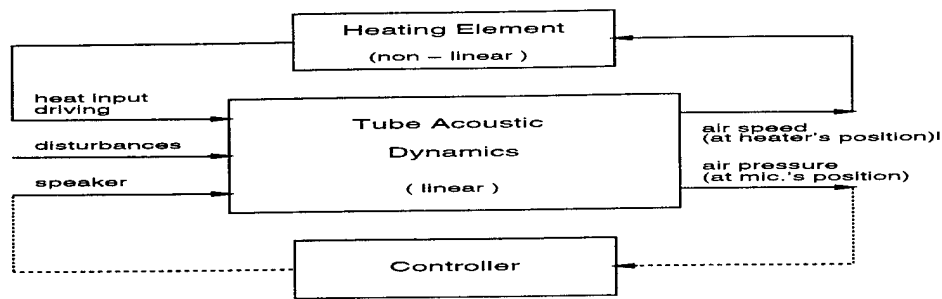

Figure 14: Proposed Model

The acoustic dynamics are passive and therefore stable, but under certain conditions the feedback provided by the heating element (thermo-acoustic feedback) makes the overall resulting system unstable. The inherent non-linearity of this feedback is one of the factors that will limit the amplitude of the oscillations established.

The objective of the controller is to prevent the thermo-acoustic feedback from shifting the system from a stable into an unstable one. This objective is accomplished by modifying the acoustic behavior of the tube.

Another approach to this problem is to act on the heat releasing element and modify the thermo-acoustic feedback characteristics, however this requires an accurate model of the underlying phenomena in the heat exchange process. The mechanical design of the actuators for this approach is also harder.

6.4 System Identification

As has been stated in the preceding section we only need a linear model for the acoustic dynamics of the system. We lump the dynamics of the amplifier, speaker, tube and microphone into a single system, and we measure its transfer function. This is done by applying a periodic chirp signal, with energy content in the relevant band, to the audio amplifier input (d), and measuring the output of the microphone (y). To obtain a better signal to noise ratio, we repeat the experiment 30 times and average the results.

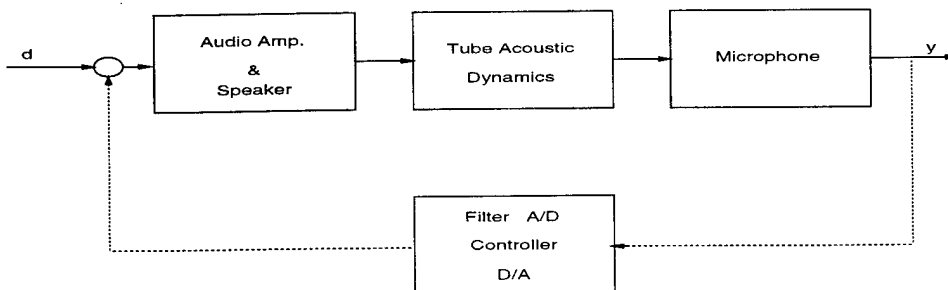

Figure 15: System I.D. and controller setup

For computational purposes we approximate this transfer function with a state space realization of the modal system:

$$\frac{y(s)}{d(s)} \approx H(s) := \sum_{n=1}^M \frac{b_n c_n}{s^2 + 2\delta_n \omega_n s + \omega_n^2}$$

Figure 16 compares the measured transfer function with this analytical approximation.

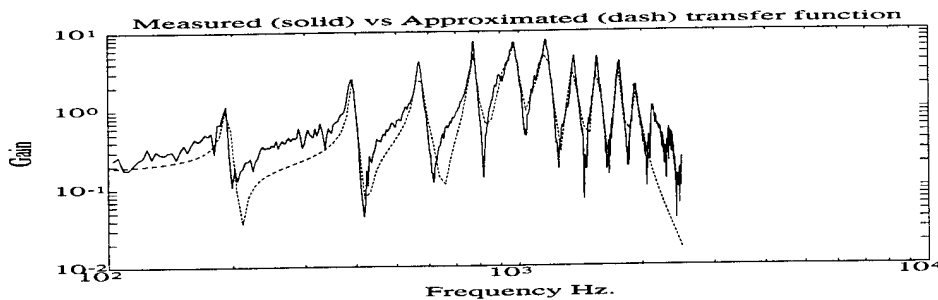

Figure 16: Measured transfer function and analytical approximation

In order to carry out these measurements, we need to place the system at a stable operating point. This is best achieved by using a higher air flow rate than the one at which the acoustics inside the tube are unstable. Figure 17 describes qualitatively this situation. This implies that the controller will be used on a system different than the one modelled, and therefore places an additional requirement on its robustness: the region in which the required performance is achieved has to include a neighborhood of the point o .

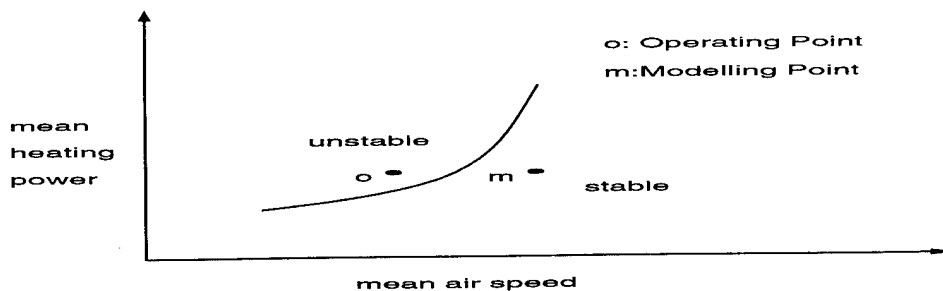

Figure 17: Qualitative description of robustness requirements

6.5 Controller Design

As can be seen in figure 16 the transfer function presents resonance modes with a high selectivity factor Q defined as:

$$Q := \frac{\omega_{max}}{\Delta\omega}$$

where ω_{max} is the frequency at which the relative maximum is achieved and $\Delta\omega$ is the 3dB bandwidth. (The relative value of Q can be estimated by the aspect of the peak: the sharper the peak, the higher the selectivity factor.)

In the modal representation of the system, a high selectivity factor of a resonance mode corresponds to a damping factor δ much smaller than one, or equivalently to poles close to the imaginary axis.

The performance objective of the controller is to simultaneously lower the Q factor of the first two resonance modes. We follow the Loop Shaping controller design procedure described in [34], which consists of 3 steps.

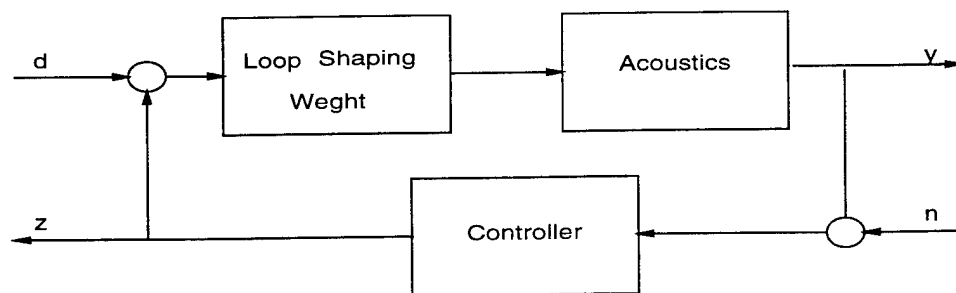

Figure 18: Loop Shaping design setup

First, we select the open loop loop-shape L needed to obtain our performance specification. In our case we require $L \gg 1$ over the frequency range we want to control, as this leads to a flat closed loop response in that range. Additional factors, e.g. the available bandwidth of the controllers, will restrict the achievable performance and have to be taken into account while designing the loop-shape. We then design a Loop-Shaping weight W_{LS} such that $L(s) = W_{LS}(s)H(s)$.

The loop shaping weight we use is:

$$W_{LS} = \frac{7}{(s + 1500)(s + 3000)^2}$$

Next, we design a compensator to make the closed loop system stable. The compensator design must also make sure that command efforts are kept within operational limits of the actuators. This is achieved by designing the controller which stabilizes the plant and minimizes $\|G\|_\infty$ where G is defined by (see figure 18) :

$$\begin{pmatrix} y \\ z \end{pmatrix} = G(s) \begin{pmatrix} d \\ n \end{pmatrix}$$

Finally the actual feedback controller is constructed by combining the Loop Shaping weight and the H_∞ compensator.

For our application we also reduce the order of the controller using balanced model reduction, and convert the continuous time controller into a discrete time controller. The controller we designed following this procedure has order 14.

6.6 Results

Figures 19 and 20 compare the open and closed loop transfer functions of the system. The Q factors of the first two modes were reduced from 34 and 42 to 10 and 20 respectively. This is enough to prevent the system from going into limit cycles. The controller can also bring the system back from unstable to stable operation.

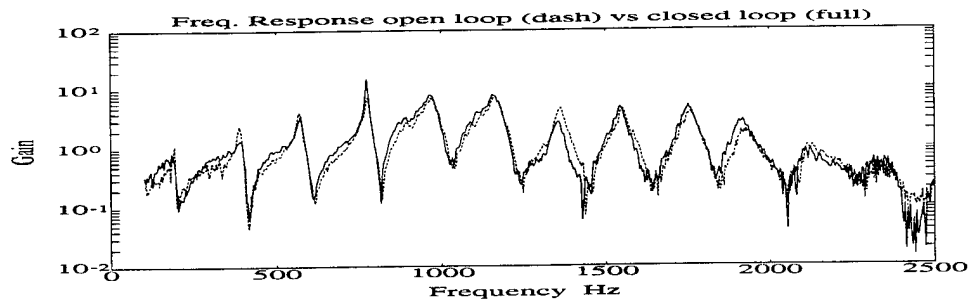

Figure 19: Comparison of open and closed loop transfer functions

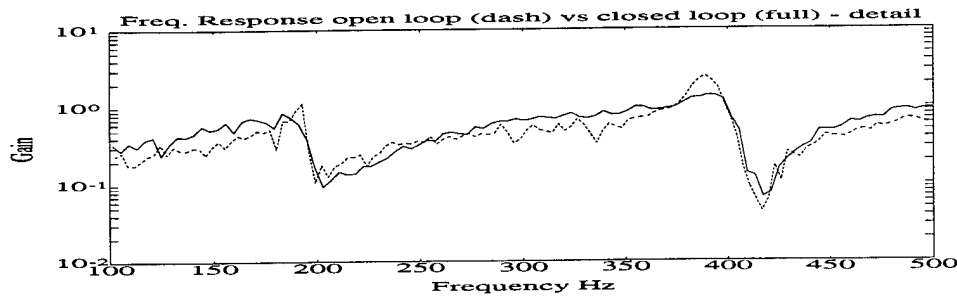

Figure 20: Comparison of open and closed loop transfer functions for the first two modes

Figure 21 shows a power spectrum of the pressure waves inside the tube when air flow and heat input mean values are set to an unstable operating point. When the controller is used the limit cycle power levels are reduced by at least 60db in the first two modes. In Figure 22 we show an interval of the time record of the output of the microphone for both the open and closed loop configuration.

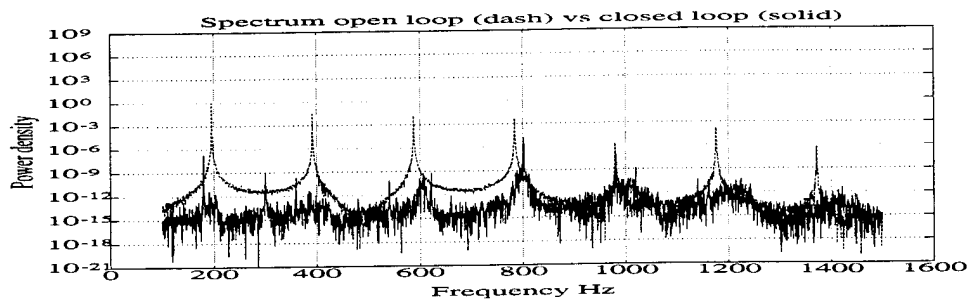

Figure 21: Comparison of open and closed Loop power spectrums

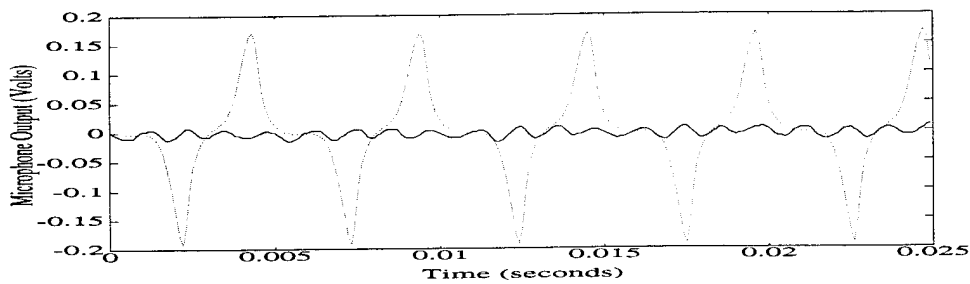

Figure 22: Comparison of open and closed Loop time records

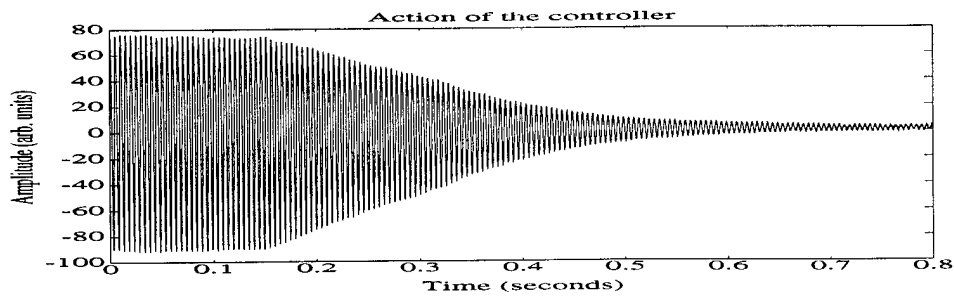

Figure 23: Action of the controller on the Limit Cycle

References

- [1] G. Balas, J. Doyle, K. Glover, A. Packard, and R. Smith, "The μ analysis and synthesis toolbox." MathWorks and MUSYN, 1991.
- [2] Beck, C., Doyle, J., and Glover, K., 1993, "Reducibility of Uncertain Systems", report in preparation
- [3] Beck, C., Doyle, J., 1994, "Realization Theory for Uncertain Systems", report in preparation
- [4] Beck, C., and Doyle, J., 1992 "Mixed μ upper bound computation," *1992 IEEE CDC*.
- [5] Beck, C., and Doyle, J., 1993 "Model Reduction of Behavioral Systems," *1993 IEEE CDC*.
- [6] H. Bercovici, C. Foias and A. Tannenbaum "Structured Interpolation Theory", in *Operator Theory: Advances and Applications* vol. 47 pp. 195 -220
- [7] Bernstein D.S, Haddad W.H., *LQG Control with an \mathcal{H}_∞ Performance Bound: A Riccati Equation Approach*, IEEE Trans. Automatic Control, Vol 34, 3, pp. 293-305, 1989.
- [8] Boyd, S., and El Ghaoui, L., 1993, "Method of Centers for Minimizing Generalized Eigenvalues", *Linear Algebra and its Applications*
- [9] Braatz, R., Young, P., Doyle, J., Morari, M., 1993 "Computational complexity of μ calculation", to appear in *IEEE Transactions on Automatic Control*.
- [10] Culick F., Lin W., Jahnke C., Sterling J. "Modeling for Active Control of Combustion and Thermally Driven Oscillations". *Proceedings of the 1991 American Control Conference* pp. 2939- 2947
- [11] D'Andrea R., Paganini F., Doyle J.C., *Uncertain Behavior*, Proceedings 1993 CDC, San Antonio, Texas, pp. 3891-3896.
- [12] D'Andrea R., Paganini F., *Interconnection of Uncertain Behavioral Systems for Robust Control*, Proceedings 1993 CDC, San Antonio, Texas, pp. 3642-3647.
- [13] J. Demmel, "The componentwise distance to the nearest singular matrix," *SIAM Journal on Matrix Analysis and Applications*, vol. 13, pp. 10-19, 1992.
- [14] J. Doyle, "Analysis of feedback systems with structured uncertainty," *IEE Proceedings, Part D*, vol. 129, pp. 242-250, Nov. 1982.
- [15] Doyle J., Newlin M., D'Andrea R., Paganini F., and Tierno J., *Unifying Robustness Analysis and System ID* Submitted to 1994 CDC, Orlando, Florida

- [16] J. Doyle, A. Packard, and K. Zhou, "Review of LFTs, LMIs and μ ," in *Proceedings of the 30th Conference on Decision and Control*, pp. 1227-1232, 1991.
- [17] Kavranoglu, D., and Bettayeb, M., 1992, "Optimal H_∞ General Distance Problem with Degree Constraint", preprint
- [18] Enns, D.F., 1984, *Model Reduction for Control System Design*, Ph.D. Dissertation, Stanford University.
- [19] Heckl M. "Active Control of the Noise from a Rijke Tube", *Journal of Sound and Vibration* (1988) **124**(1), pages 117-133.
- [20] Glover, K., 1984, "All optimal Hankel-norm approximations of linear multivariable systems and their L^∞ -error bounds", *Int. J. Control.*, Vol.39:1115-1193.
- [21] M. R. Garey and D. S. Johnson, *Computers and Intractability: A Guide to the Theory of NP Completeness*. New York: W. H. Freeman, 1979.
- [22] Hall S., How J., *Mixed \mathcal{H}_2/μ Performance Bounds using Dissipation Theory*, Proc. 1993 CDC, San Antonio, TX, pp 1536-1541.
- [23] Hinrichsen, D. and Pritchard, A.J., 1990, "An improved error estimate for reduced-order models of discrete-time systems", *IEEE Trans. on Auto. Control*, AC-35:317-320.
- [24] IEEE Proceeding, 1977, Special issue on multidimensional systems.
- [25] Khargonekar P., Rotea M., *Mixed $\mathcal{H}_2/\mathcal{H}_\infty$ Control: A convex Optimization Approach*, IEEE Trans. A.C., Vol 36, 7, pp. 824-837, 1991.
- [26] Kuijper M., *First-Order Representations of Linear Systems* Ph.D. Dissertation Thesis, University of Brabant, 1992.
- [27] Lang W., Poinot T., Candel S. "Active Control of Combustion Instabilities", *Combustion and Flame* vol. 70, 1987 pp.281-289.
- [28] Ljung L., *System Identification* Prentice Hall, 1987
- [29] Lu, W., and Doyle, J., 1992, " H_∞ control of LFT systems: an LMI approach," *1992 IEEE CDC*.
- [30] Lu, W., Zhou, K., and Doyle, J.C., 1993, "Stabilization of Linear Systems with Structured Perturbations", Technical Memorandum No. CIT-CDS 93-014, Calif. Inst. of Tech.
- [31] Lu, W.M. and J.C. Doyle (1992), " \mathcal{H}_∞ -Control of LFT Systems: An LMI Approach", *Proc. 31st IEEE CDC*, Tucson, AZ., pp. 1997-2001.
- [32] Lu, W.M. and J.C. Doyle (1993), " \mathcal{H}_∞ -Control of Nonlinear Systems: a Convex Characterization", *Caltech CDS Tech. Memo.*, No.CIT-CDS-93-020. also *Proc. 1994 ACC*, Baltimore, MD.

- [33] Lu, W.M. and J.C. Doyle (1994), "A State Space Approach to Robustness Analysis and Synthesis of Nonlinear Uncertain Systems", Submitted to *1994 IEEE CDC*.
- [34] McFarlane D.C., Glover K. "Robust Controller Design Using Normalized Coprime Factor Plant Descriptions", *Lecture Notes in Control and Information Sciences* Vol 138. Springer-Verlag 1989.
- [35] Megretski, A., 1993, "Necessary and Sufficient Conditions of Stability: A Multiloop Generalization of the Circle Criterion", *IEEE Trans. on Auto. Control*, Vol. 38, No. 5
- [36] Megretski A., *S-Procedure in Optimal Non-Stochastic Filtering*, Tech. Rep. Code Trita/Mat-92-0015, Royal Inst. of Tech., Sweden.
- [37] Megretski, A., and Treil, S., 1990-91, "S-Procedure and Power Distribution Inequalities: A New Method in Optimization and Robustness of Uncertain Systems", Mittag-Leffler Institute, Rep. No. 1
- [38] B.C. Moore, 1981, "Principal Component Analysis of Linear Systems: Controllability, Observability and Model Reduction", *IEEE Trans. Automat. Control*, Vol. 26, 17-32.
- [39] Newlin, M., *Model validation and generalized μ* PhD thesis, in preparation.
- [40] Newlin, M., Smith, R., "A Generalization of the Structured Singular Value and its Application to Robust Minimum Gain Problems and Model Validation" submitted to *IEEE Trans. Automat. Control*.
- [41] Newlin, M., and Young, P., "Mixed μ problems and Branch and Bound techniques," *32nd IEEE CDC*.
- [42] Packard, A., "Notes for LFT Optimal Control", University of California, Berkeley, Department of Mechanical Engineering Report, 1992
- [43] Paganini F., *Set Descriptions of White Noise and Worst Case Induced Norms*, Proceedings 1993 CDC, San Antonio, Texas, pp. 3658-3663.
- [44] A. Packard and J. C. Doyle, "The complex structured singular value" in *Automatica* Vol 29(1), pp. 71 -109, 1993
- [45] Packard A., Doyle J.C., Balas G., "*Linear, Multivariable Robust Control with a μ -Perspective*," *Journal of Dynamic Systems Measurement and Control-Transactions of the ASME*, Vol. 115, pp. 426-438, 1993.
- [46] Packard, A., K. Zhou, P. Pandey, and G. Becker (1991), "A Collection of Robust Control Problems Leading to LMIs", *Proc. of 1991 IEEE CDC*, Brighton, England, pp.1245 - 1250.
- [47] Paganini, F., 1993, "Set Descriptions of White Noise and Worst Case Induced Norm," *33rd IEEE CDC*.

- [48] Paganini, F., and Doyle, J., 1994, "Necessary Conditions for Analysis of Uncertain Behaviors", submitted to *33rd CDC*, Florida
- [49] Poola K, Tikku A., "Robust Performance against Time-Varying Structured Perturbations," submitted to *IEEE Transactions on Automatic Control*
- [50] A. Rantzer, "Uncertainties with Bounded Rates of Variation," *Proceedings of the American Control Conference*, pp. 29-30 1993.
- [51] Rantzer, A., and Megretski, A., 1994, "Integral Quadratic Constraints (IQC:s) as a Unifying Concept", submitted to *33rd CDC*, Florida
- [52] J. Rohn and S. Poljak, "Checking robust nonsingularity is NP-hard." to appear in *Mathematics of Control, Signals and Systems*.
- [53] Schumacher J.M., "*Linear System Representations*," Lecture Notes in Control and Information Sciences, Vol 135, pp. 382-408, Springer-Verlag, 1989.
- [54] Shamma, J., 1993, "Robust Stability with Time-Varying Structured Uncertainty", to appear *IEEE Trans. on Auto. Control*
- [55] Shamma, J.S. and R. Zhao (1993), "Fading Memory Feedback Systems and Robust Stability", *Automatica*, Vol.29, pp.191 - 200.
- [56] Weiland S., *Theory of Approximation and Disturbance Attenuation for Linear Systems* Ph.D. Dissertation Thesis, University of Groningen, 1991.
- [57] Smith, R., and Doyle, J., 1992, "Model validation: a connection between robust control and identification," , *IEEE T-AC*, July, 1992.
- [58] Stoorvogel A.A., *The Robust \mathcal{H}_2 Control Problem: A Worst-Case Design*, *IEEE Trans. A.C.*, Vol 38, 9,pp. 1358-1370, 1993.
- [59] Sznaier M., *An (Almost) Exact Solution to General SISO Mixed $\mathcal{H}_2/\mathcal{H}_\infty$ Problems via Convex Optimization*, *Proceedings 1993 ACC*, San Francisco, CA, pp. 250-254.
- [60] J. Tierno and J. C. Doyle, "Robustness Analysis in Finite Time Horizon" submitted to the *33rd IEEE Conference on Decision and Control*
- [61] J. E. Tierno and P. M. Young, "An improved μ lower bound via adaptive power iteration." 31st Conference on Decision and Control, 1992.
- [62] Verghese G.C. et al., "*A Generalized State-Space for Singular Systems*," *IEEE Transactions on Automatic Control*, Vol. 26, No. 4, pp. 811-830, 1981.
- [63] Wang, W., Doyle, J., Beck, C., and Glover, K., 1991, "Model Reduction of LFT Systems", *Proceedings, 30th CDC*, Brighton, England

- [64] Willems J.C., *Paradigms and Puzzles in the Theory of Dynamical Systems*, IEEE Trans. A.C., Vol. 36, pp. 259-294, 1991.
- [65] Willems J.C., "Feedback in a Behavioral Setting," *Systems, Models and Feedback: Theory and Applications*, pp.179-191, 1992.
- [66] P. M. Young and J. C. Doyle, "Computation of μ with real and complex uncertainties," *Proceedings of the 29th Conference on Decision and Control*, pp. 1230-1235, IEEE, 1990.
- [67] Young, P., Newlin, M., and Doyle, J., 1992 "Practical computation of the mixed μ problem," *1992 ACC*.
- [68] Young, P., Newlin, M., and Doyle, J., "Let's get real," *1992 ASME*.
- [69] Zhou, K. and Doyle, J., 1990, *Notes on MIMO Control Theory*, unpublished note.
- [70] Zhou K., Doyle J., Glover K., Bodenheimer, B., *Mixed \mathcal{H}_2 and \mathcal{H}_∞ Control*, Proc. 1990 ACC, San Diego, CA, pp 2502-2507.