

AL/CF-TR-1994-0163

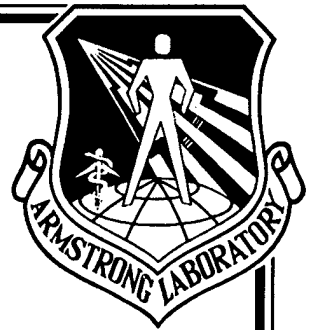

**ARMSTRONG
LABORATORY**

**CONTROLLER STUDIES FOR
DEXTEROUS HAND MANIPULATION**

Daniel W. Repperger

**CREW SYSTEMS DIRECTORATE
BIODYNAMICS AND BIOCOMMUNICATIONS DIVISION
WRIGHT-PATTERSON AFB OH 45433-7008**

19950928 003

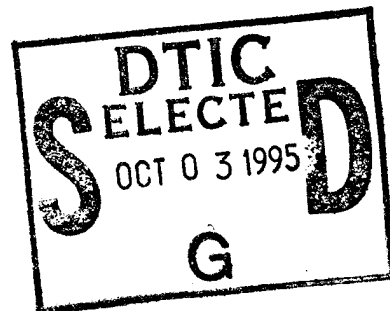

OCTOBER 1994

FINAL REPORT FOR THE PERIOD OCTOBER 1987 TO OCTOBER 1994

Approved for public release; distribution is unlimited

DTIC QUALITY INSPECTED 5

**AIR FORCE MATERIEL COMMAND
WRIGHT-PATTERSON AIR FORCE BASE, OHIO 45433-6573**

NOTICES

When US Government drawings, specifications, or other data are used for any purpose other than a definitely related Government procurement operation, the Government thereby incurs no responsibility nor any obligation whatsoever, and the fact that the Government may have formulated, furnished, or in any way supplied the said drawings, specifications, or other data, is not to be regarded by implication or otherwise, as in any manner licensing the holder or any other person or corporation, or conveying any rights of permission to manufacture, use, or sell any patented invention that may in any way be related thereto.

Please do not request copies of this report from the Armstrong Laboratory. Additional copies may be purchased from:

National Technical Information Service
5285 Port Royal Road
Springfield, Virginia 22161

Federal Government agencies registered with the Defense Technical Information Center should direct requests for copies of this report to:

Defense Technical Information Center
Cameron Station
Alexandria, Virginia 22314

TECHNICAL REVIEW AND APPROVAL

AL/CF-TR-1994-0163

This report has been reviewed by the Office of Public Affairs (PA) and is releasable to the National Technical Information Service (NTIS). At NTIS, it will be available to the general public, including foreign nations.

This technical report has been reviewed and is approved for publication.

FOR THE DIRECTOR



THOMAS J. MOORE, Chief
Biodynamics and Biocommunications Division
Armstrong Laboratory

REPORT DOCUMENTATION PAGE

Form Approved
OMB No. 0704-0188

Public reporting burden for this collection of information is estimated to average 1 hour per response, including the time for reviewing instructions, searching existing data sources, gathering and maintaining the data needed, and completing and reviewing the collection of information. Send comments regarding this burden estimate or any other aspect of this collection of information, including suggestions for reducing this burden, to Washington Headquarters Services, Directorate for Information Operations and Reports, 1215 Jefferson Davis Highway, Suite 1204, Arlington, VA 22202-4302, and to the Office of Management and Budget, Paperwork Reduction Project (0704-0188), Washington, DC 20503.

1. AGENCY USE ONLY (Leave blank)	2. REPORT DATE October 1994	3. REPORT TYPE AND DATES COVERED Final - October 1987 to October 1994	
4. TITLE AND SUBTITLE Controller Studies for Dexterous Hand Manipulator		5. FUNDING NUMBERS PE - 0601101F PR - 7231 TA - 38 WU - D3	
6. AUTHOR(S) D.W. Repperger		8. PERFORMING ORGANIZATION REPORT NUMBER AL/CF-TR-1994-0163	
7. PERFORMING ORGANIZATION NAME(S) AND ADDRESS(ES) Armstrong Laboratory, Crew Systems Directorate Biodynamics and Biocommunications Division Human Systems Center Air Force Materiel Command Wright-Patterson AFB OH 45433-7022		9. SPONSORING/MONITORING AGENCY NAME(S) AND ADDRESS(ES)	
10. SPONSORING/MONITORING AGENCY REPORT NUMBER		11. SUPPLEMENTARY NOTES	
12a. DISTRIBUTION/AVAILABILITY STATEMENT Approved for public release; distribution is unlimited		12b. DISTRIBUTION CODE	
13. ABSTRACT (Maximum 200 words) The UTAH/MIT dexterous hand is a robotic manipulator built to emulate the human tendon system. When using this robotic system, it was observed that when motion occurred at the lower joints, the upper joints moved through inertial coupling. The coupling was always from a proximal joint to a distal joint. It was desired to find a method to add a controller action such that additional joint inputs could be added to the upper joints and thus preclude the coupling effects induced as the joints rotate. A controller was designed and tested in a numerical simulation at Wright State University as part of a Masters of Science degree in Electrical Engineering. With the use of the controller, over 90% of the coupling effects could be reduced with the use of the algorithm developed.			
14. SUBJECT TERMS Robotic hand manipulator, Dexterous device			15. NUMBER OF PAGES 20
			16. PRICE CODE
17. SECURITY CLASSIFICATION OF REPORT UNCLASSIFIED	18. SECURITY CLASSIFICATION OF THIS PAGE UNCLASSIFIED	19. SECURITY CLASSIFICATION OF ABSTRACT UNCLASSIFIED	20. LIMITATION OF ABSTRACT UNLIMITED

THIS PAGE LEFT BLANK INTENTIONALLY.

PREFACE

An extremely dexterous robotic hand manipulator has been built by the University of Utah and is called the UTAH/MIT Dexterous Hand. This device was located in Building 441 of AL/CFBA and was the subject of several investigations related to the use of robotic manipulators in applications involving hazardous environments.

The UTAH/MIT Dexterous Hand was constructed in such a manner as to emulate human hand motion. It has tendon actuators which mimic those which appear in humans. Also analogous to a human system, the power that actuates the hand motion is produced at a remote location, distal from the actual hand. This centralization of the actuator power source is termed the "remotizer" and produces forces using a pneumatic system.

The Dexterous Hand, itself, consists of four fingers, each of which has three links. This design also has similarities to the human motor system. When dynamic tests were conducted at the Armstrong Laboratory on this robotic manipulator, coupling between the links was observed to occur when the lower joint (most proximal) was actuated by a sine wave signal. This inertial and friction coupling compromised performance of this device. This is true because if only one link was to be moved, the other two links would displace, thus precluding motion in only one link. This research effort focused on methods of designing a controller that would add input commands into the more distal joints, thus reducing the induced coupling that would occur. Consequently the Dexterous Hand could then be controlled for tasks requiring precise movement because more accurate positioning would then be obtained, independently, of each link.

Accession For	
NTIS CRA&I	<input checked="" type="checkbox"/>
DTIC TAB	<input type="checkbox"/>
Unannounced	<input type="checkbox"/>
Justification	
By	
Distribution /	
Availability Codes	
Dist	Avail and/or Special
A-1	

THIS PAGE LEFT BLANK INTENTIONALLY.

TABLE OF CONTENTS

	<u>Page</u>
PREFACE.....	iii
INTRODUCTION - AN AIR FORCE NEED.....	1
The Merlin 6500 System.....	4
The UTAH/MIT Dexterous Hand Manipulator.....	4
Kinematics and Dynamics (K&D) Properties.....	4
Kinematics and Dynamics of the Merlin 6500 System.....	4
Kinematics and Dynamics of The UTAH/MIT Hand Manipulator.....	5
Static and Dynamic Testing of the UTAH/MIT Hand.....	5
Part I - Static Calibration.....	5
Part II - Dynamic Describing Function Measurements.....	7
Controller Solution to the Coupling Problem.....	11
Controller Design to Mitigate Coupling Effects.....	12
Efficacy of the Controller Solution.....	13
SUMMARY AND CONCLUSIONS.....	13
REFERENCES.....	14

LIST OF FIGURES

<u>Figure</u>		<u>Page</u>
1	The Merlin 6500 Manipulator Frame Assignments - Side View.....	1
2	The Merlin 6500 Manipulator Frame Assignments - Plan View.....	2
3	The Utah/MIT Dexterous Hands - Plan View.....	2
4	The Utah/MIT Dexterous Hands - Elevation View.....	3
5	The Utah/MIT Dexterous Hand.....	3
6	The Hysteresis Curve - Elbow Joint = 180 Degrees.....	6
7	The Hysteresis Curve - Elbow Joint = 90 Degrees.....	7
8	The Details of Tendon Routing.....	9
9	Transfer Function (TF) of Joint 1 - Input on Joint 1.....	10
10	Coupled TF of Joint 2 - Input on Joint 1.....	10
11	Pneumatic Actuation System.....	11
12	Bandwidth Response of The Three Joints.....	12

LIST OF TABLES

<u>Table</u>		<u>Page</u>
1	Input-Output Measurements.....	8
2	Transfer Function Matrices.....	8

INTRODUCTION - AN AIR FORCE NEED

The Air Force has a need to maintain force survivability and base operability during wartime scenarios in chemical, biological, and radiological environments. Therefore, it is important to project human intelligence, perceptual capabilities, and motor skills into hostile environments using human driven robotic systems, thereby removing the human from the hazardous environment. Research needs to be accomplished on the feasibility of employing remote human-in-the-loop control of mobile dexterous robots to perform tasks such as aircraft inspection and servicing, explosive ordnance disposal, and environmental monitoring and decontamination. One such concept [1], termed, "robotic telepresence" projects human judgment, dexterity, and adaptability in real time into a lethal environment. The goal is to attach known robot manipulation systems in concatenation such that they may help augment the human's function in environments which may be hazardous. We discuss two such manipulation systems that may be used, in a synergistic manner with each other, to help increase the human's capability. The first system is the Merlin 6500 manipulator (Figures 1 & 2). This system is very similar to a Puma 560 robot commonly used in industry applications and can be considered very useful for the "gross motion control" aspect of manipulator movement. The second system utilized is the UTAH/MIT [2] Dexterous Hand (Figures 3-5). This second system is considered for the "fine motion control" problem. The key to success is to integrate these systems together to have both the benefits of gross and fine motion control. The desired scenario is to have the Merlin 6500 manipulator system secure and move the UTAH/MIT device. The UTAH/MIT device would perform the fine motion actions, and the Merlin 6500 would perform all necessary gross motions. We now describe, in greater detail, these two separate manipulator systems.

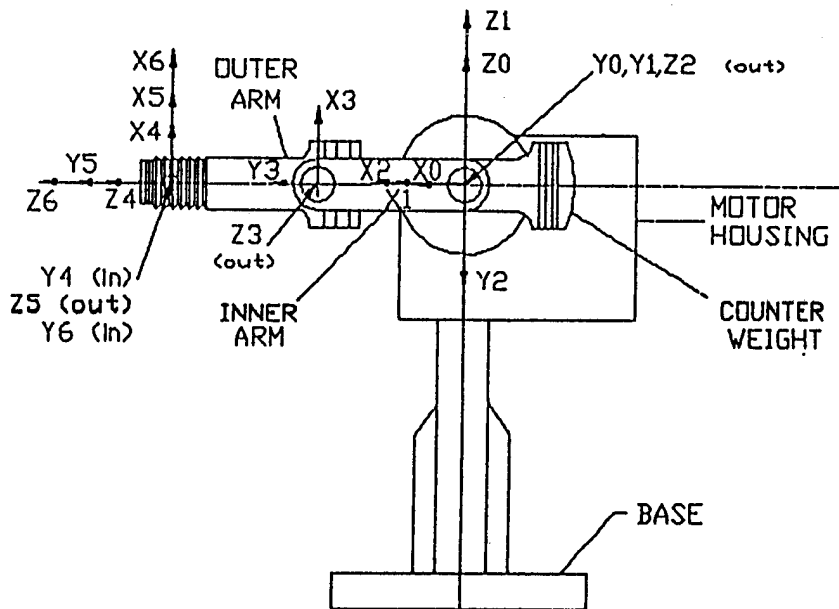

Figure 1. The Merlin 6500 Manipulator Frame Assignments - Side View

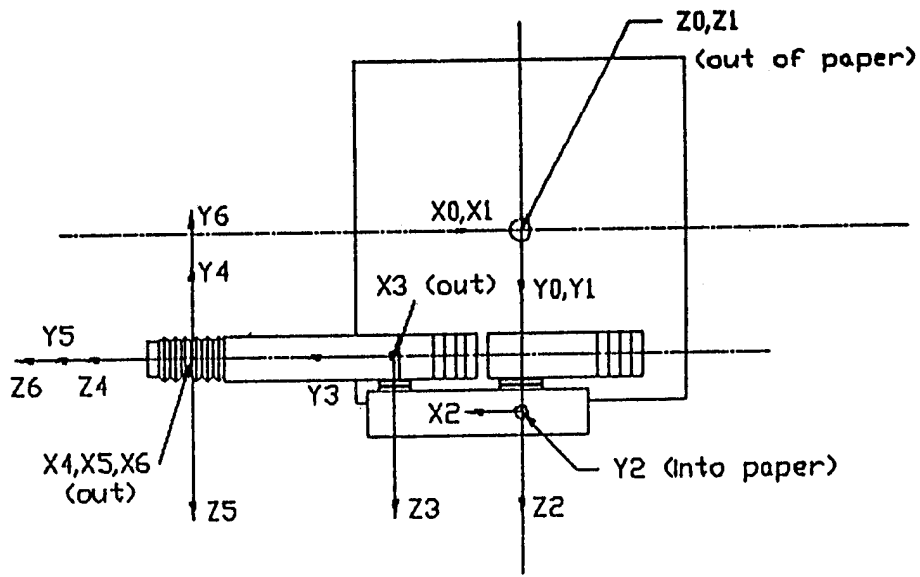

Figure 2. The Merlin 6500 Manipulator Frame Assignments - Plan View

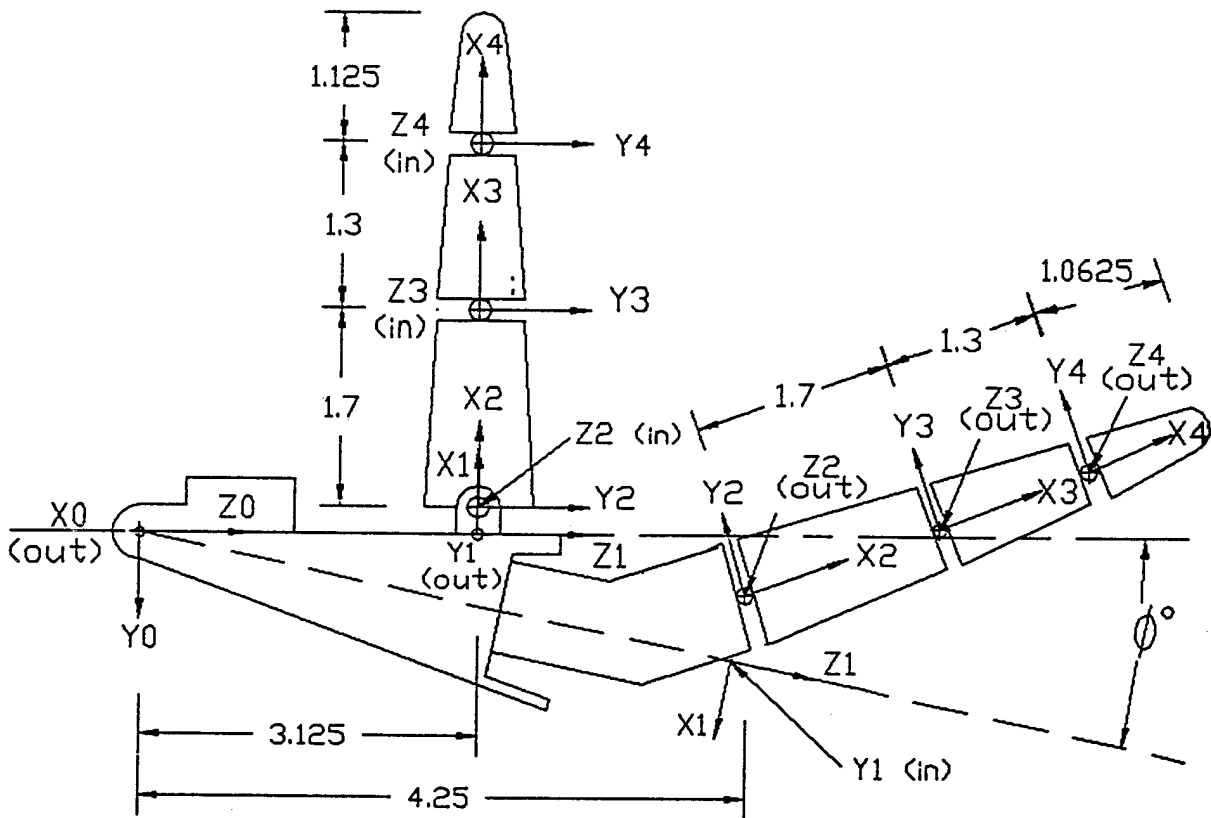

Figure 3. The Utah/MIT Dexterous Hands - Plan View

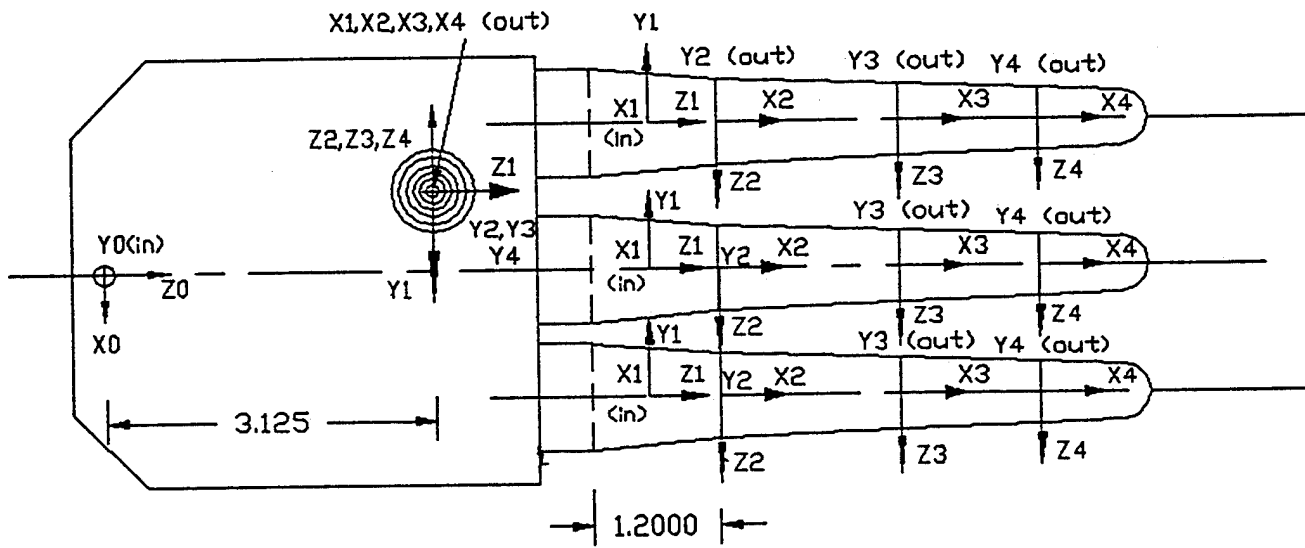

Figure 4. The Utah/MIT Dexterous Hands - Elevation View

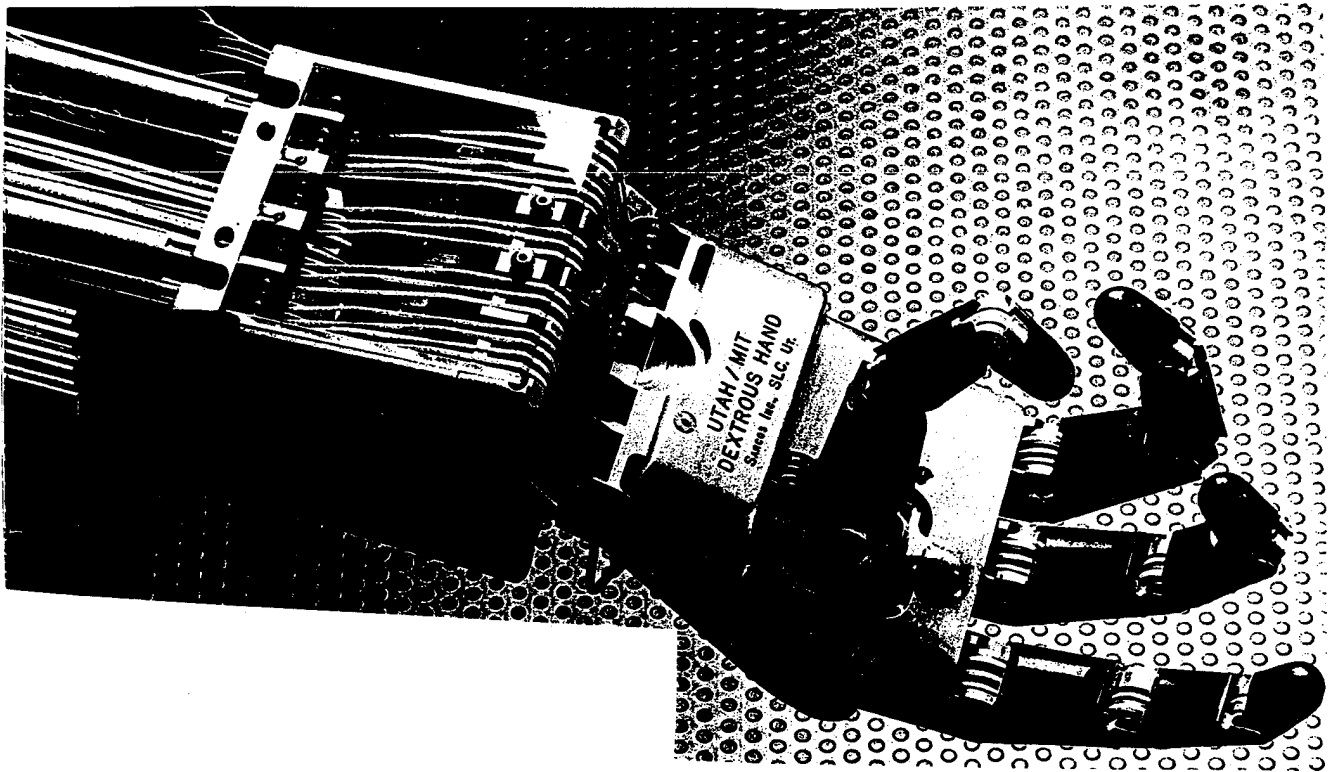

Figure 5. The Utah/MIT Dexterous Hand

The Merlin 6500 System

The Merlin 6500 System (Figures 1 & 2) is designed to emulate anthropomorphic motions made by humans. It is a six degree of freedom robotic manipulator. The first three degrees of freedom consist of position variables and emulate human waist motion, human shoulder motion, and elbow motion. The last three degrees of freedom are basically orientation variables and describe pitch, yaw, and roll properties of the end effector at the wrist. Even with these six degrees of freedom, they all fall into the category of "gross motion control." There is little opportunity to perform fine manipulation tasks with this device. Each joint is actuated by a DC stepper, torque motor which uses as position feedback, optical encoders. Since each joint is configured as a position control system, it has little opportunity to perform very fine motor control. The task of the fine manipulation, however, can be realized with the UTAH/MIT Dexterous Hand.

The UTAH/MIT Dexterous Hand Manipulator

The UTAH/MIT Dexterous Hand Manipulator [2] was developed from the need to perform research for comprehensive assembly tasks which require refined manipulation capability. By having a total of 16 degrees of freedom (defined within the context of robotic systems) at the end effector, one can focus this device on the "fine motion control" problem. It has applicability for both tactile sensing and dexterous manipulation. Since the power and force delivered to the end effector are actuated at a remote location (termed the "remotizer"), the weight of the actuators and other related problems are physically removed from the end effector, thus promoting its utility for the fine manipulation tasks.

The final objective of this type of research to satisfy Air Force needs would require the integration of these two systems. This integration is kinematically complex, especially in light of the fact that both these systems would partake as a major component of a remote teleoperation system. The first step necessary in getting these systems to work in concert is to obtain a complete description of the kinematics and dynamics of operation, individually, and then consider their interaction as a unit. It is, therefore, worthwhile to investigate individual operation of each manipulator system.

Kinematics and Dynamics (K&D) Properties

Starting first with the "gross motion control problem," the Merlin 6500 System is studied to investigate how it can best be controlled.

Kinematics and Dynamics of The Merlin 6500 System

As mentioned previously, the Merlin 6500 robotic system performs very similarly to both

human motion and also the Puma 560 robot which is commonly used in industry for pick and place operations. The forward and inverse kinematics of this device are so well-known that they are commonly used as classroom examples for undergraduate level courses in robotics [3,4]. It will not be the purpose here to describe these details. They are easily found in a number of well known textbooks. The kinematic and dynamic properties of the UTAH/MIT Hand Manipulator, however, are more difficult processes to describe.

Kinematics and Dynamics of The UTAH/MIT Hand Manipulator

When viewed within the context of a robotic system, this manipulator is considered to have 16 degrees of freedom (four joints with four degrees of freedom each). Hence, there are multiple solutions to both the forward and inverse kinematics problem for this device. An extended discussion was contained in [1] relation to the kinematics problem. This technical report will address some of the dynamics problems associated with this device.

Static and Dynamic Testing of the UTAH/MIT Hand

After the UTAH/MIT Dexterous Hand arrived at the Armstrong Laboratory, it was desired to first perform several tests on the device to better understand its static and dynamic characteristics. A two-part testing procedure was conducted. The first part consisted of static measurements [5] to check linearity and other properties of interest. After the static tests were conducted, dynamic tests [6] were then initiated to observe the use of this manipulator system in a changing motion environment. The first static test involved a calibration. The purpose of this initial examination was to inspect the device's inherent linearity in a static sense as an important property to understand before any dynamic measurements are taken.

Part I - Static Calibration

On 15 October 1987, a preliminary static calibration was conducted with the UTAH/MIT Dexterous Hand. Using the right hand, the first index finger and third joint (finger tip) were involved in a flexor test. Force inputs were applied to a tendon and the finger tip was constrained to not move. The following hypotheses were tested:

(1) Linearity: With the remotizer actuated and the elbow at a 180 degree angle, a force input was applied to a tendon. The Hall Effect sensor at the base of the Dexterous Hand measured the voltage felt at this point. The force input applied changed from 0 to 20 pounds and the linearity of this plot was the data of interest to be checked.

(2) Hysteresis: The force input in the linearity test in section (1) was then reduced from 20 pounds to zero pounds. If this curve did not retrace the prior curve, then a hysteresis

effect was noted to occur (much like human muscle) due to the fact that the tendon changes its characteristics after being stressed.

(3) Sections (1) and (2) were then repeated when the elbow joint was at a 90 degree angle as compared to the original 180 degree angle originally chosen.

Results of The Calibration: Figure 6 illustrates the hysteresis curve observed with the elbow joint in the 180 degree position. Figure 7 is the same plot for the 90 elbow position. Linearity was determined by how well the plots in Figures 6 & 7 follow a straight line of force input versus measured Hall Effect Sensor voltage produced as an output. The hysteresis was determined by the lack of repeatability of the curve in returning to the equilibrium point (0 pounds force, 0 volts) from the initial point (20 pounds of force). In summary:

(a) The force sensors are linear but exhibit a worst case of 10% hysteresis due to tendon stretching.

(b) The orientation of the elbow does not seem to affect either the linearity or the hysteresis.

Knowing that a hysteresis nonlinearity exists, dynamic measurements were still conducted.

The Remotizer in 180 Degree Orientation

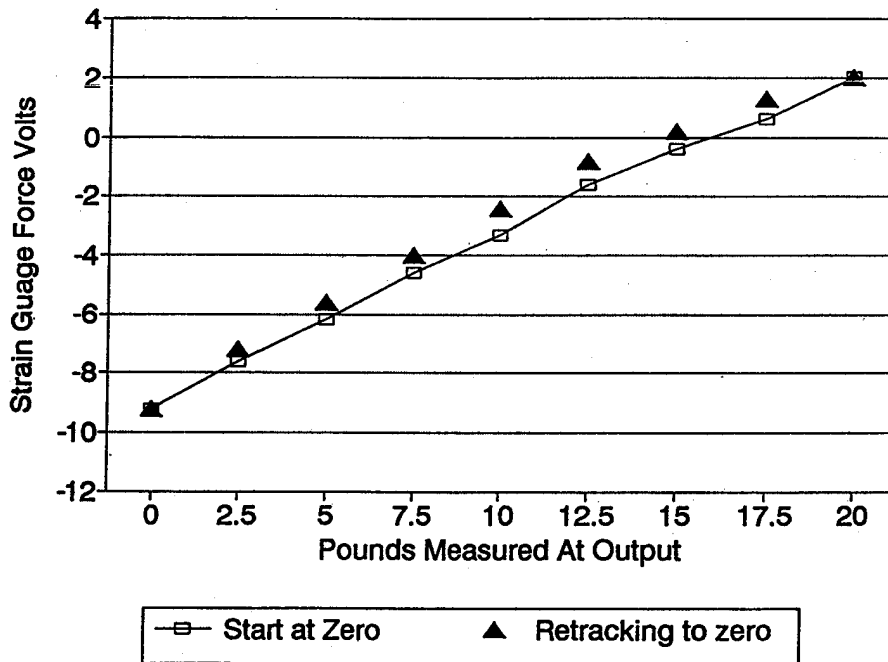

Figure 6. The Hysteresis Curve - Elbow Joint = 180 Degrees

The Remotizer in 90 Degree Orientation

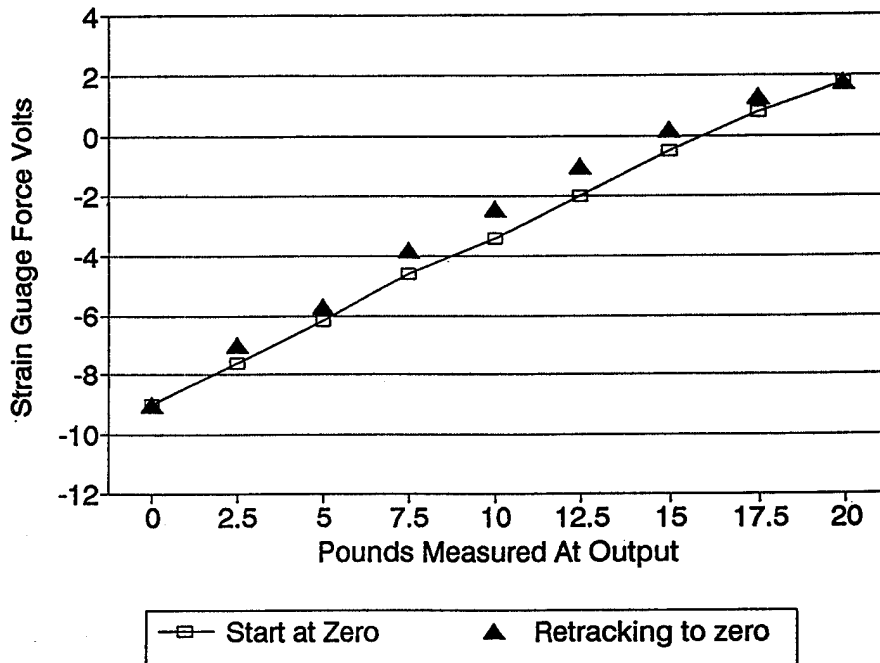

Figure 7. The Hysteresis Curve - Elbow Joint = 90 Degrees

Part II - Dynamic Describing Function Measurements

Even though the system in Part I is known to have hysteresis, it was desired to perform some describing function tests to get approximations for the transfer function characteristics of this device, for small sinusoidal disturbances. A describing function is a linear depiction of the input-output characteristics of the device in question about some operating point. The sinusoidal inputs must be small in amplitude to get approximations of transfer function characteristics. Since the system is known to be nonlinear, the resulting transfer function approximations are still useful to obtain. These characteristics, however, may be dependent (and change) with the amplitude of the input forcing function. Therefore, the following tests were conducted:

(1) At the following frequencies (0.2, 0.5, 3, 4, 5, 6, 7, 8, 9, 10, 11, 12, 15, 17, 19, 20, 25, 30, and 35 Hz) for one fixed amplitude input (± 7 volts peak to peak) voltage was applied to the control board of the remotizer for the joints described in Table I. The outputs observed are also detailed in Table I.

Table I. Input-Output Measurements

<u>Input Applied To:</u>	<u>Output Measured At:</u>
Joint 1, only	Joints 1, 2, and 3
Joint 2, only	Joints 1, 2, and 3
Joint 3, only	Joints 1, 2, and 3

Data were also collected with step function inputs to the joints described in the left most column of Table I. Table II describes the transfer function matrices obtained from these tests:

Table II. Transfer Function Matrices

Input Applied To Joint Number \longrightarrow

	Joint 1	Joint 2	Joint 3
Joint 1	$\frac{1}{(1 + s/(6*2 \text{ Pi}))^2}$	0	0
Joint 2	$\frac{Wn^2}{s^2 + 2 Z Wn s + Wn^2}$ Z= 0.1, Wn= 13 Pi	$\frac{1}{(1+ s/(16*Pi))^2}$	0
Joint 3	$\frac{Wn^2}{s^2 + 2 Z Wn s + Wn^2}$ Z= 0.08, Wn= 14 Pi	$\frac{(.06)(1+s/Pi)}{(1+s/6 \text{ Pi})(1+s/(20 \text{ Pi}))^3}$	$\frac{1}{(1+s/(14 \text{ Pi}))^2}$

Thus, from Table II it is seen that inputs applied to the lower joints always induce a coupling at the higher joints. Conversely, if inputs are applied to the higher joints, the lower joints may not experience the coupling effects. Figure 8 illustrates how this physical movement is transferred up the joints but not necessarily down the joints. To depict some of the relative transfer functions obtained from this effort, plots were made of the transfer functions of joint 1 when the input was applied at joint 1 in Figure 9. Figure 10 displays the coupling effects with the output response of joint 2 when only an input is applied to joint 1. From Figure 10, it is seen that the coupling is extensive and needs to be significantly diminished before using the UTAH/MIT Dexterous Hand for a fine manipulation task.

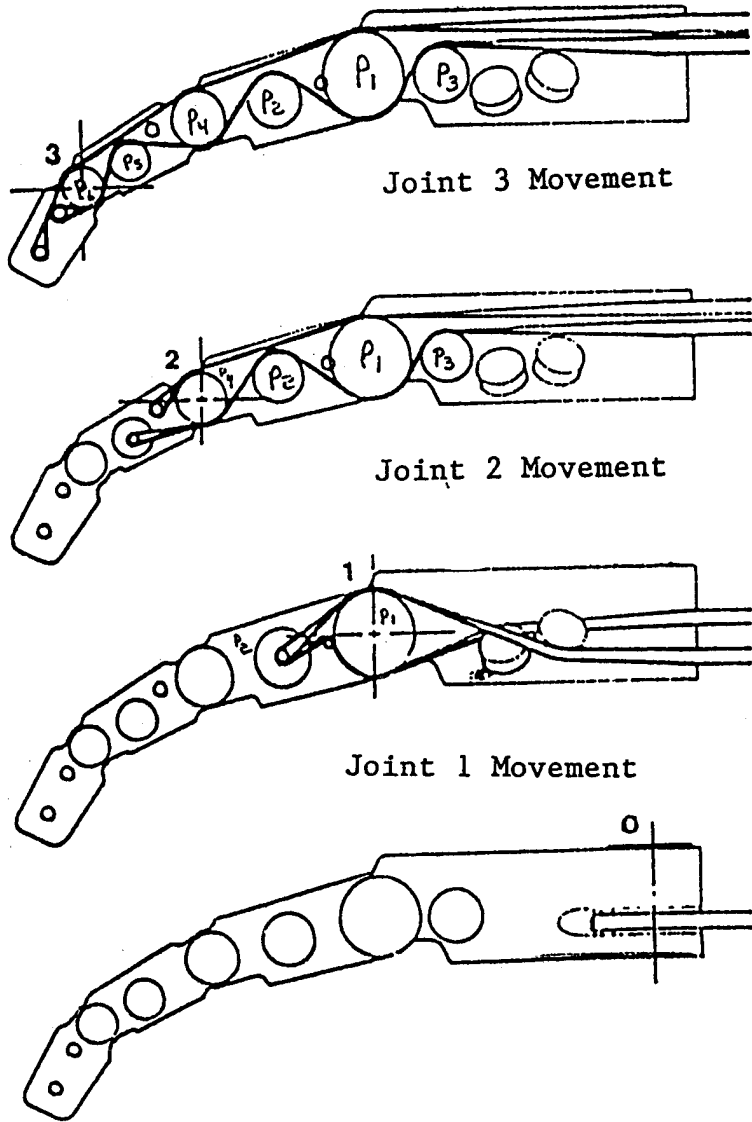

Figure 8. The Details of Tendon Routing

Transfer Function of DH

Input - Joint 1, Output Joint 1

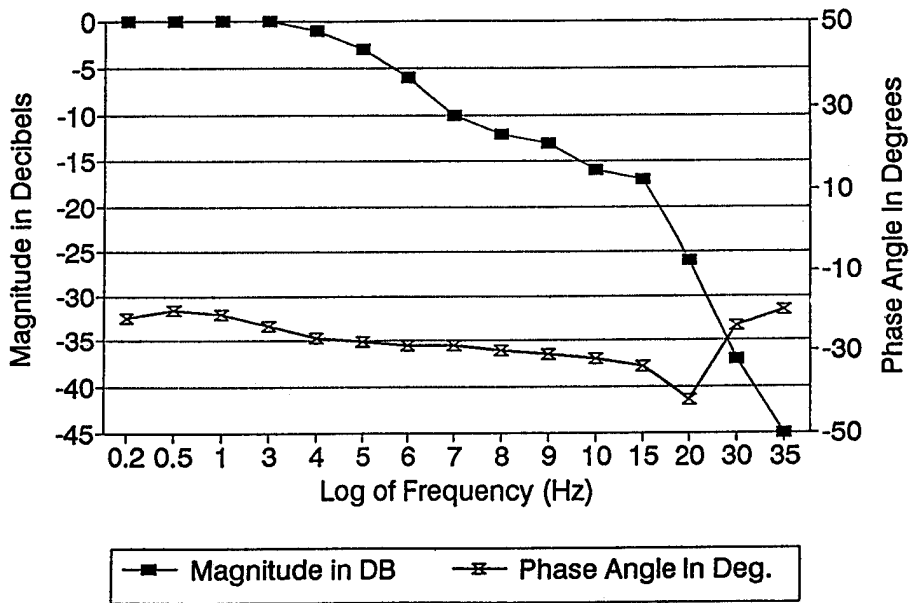

Figure 9. Transfer Function (TF) of Joint 1 - Input on Joint 1

Transfer Function of DH

Input - Joint 1, Output Joint 2

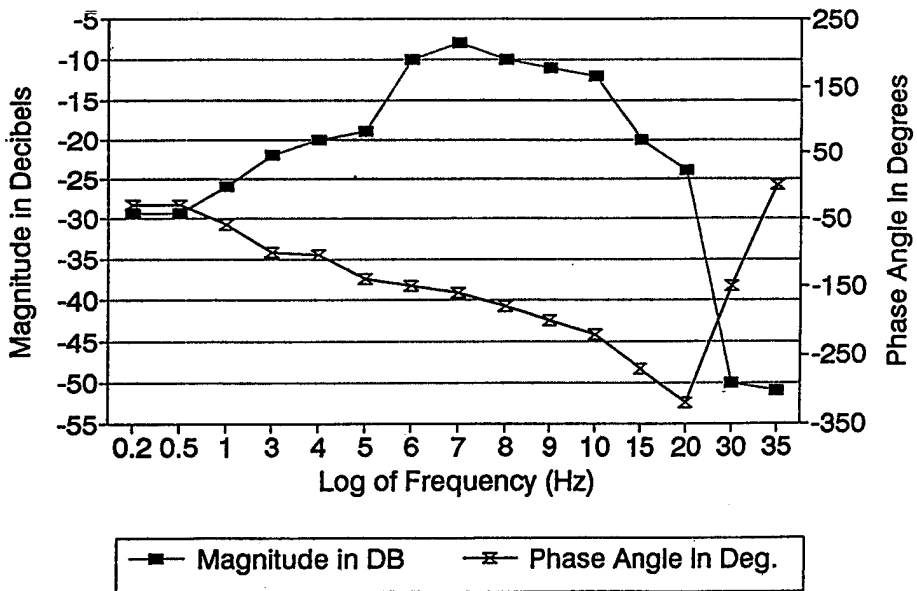

Figure 10. Coupled TF of Joint 2 - Input on Joint 1

Controller Solution to the Coupling Problem

Motivated by the laboratory tests conducted at AL/CFBA described previously, it was realized that an important problem that needs to be addressed is to develop methods of reducing coupling in the higher number joints when input commands were applied to the lower joints. At Wright State University, a Master's thesis in Electrical Engineering [1] was performed to address this problem. The results reported in the thesis were based on computer simulation only and no additional empirical data were collected from the UTAH/MIT Dexterous Hand.

A better understanding of the coupling problem can be obtained by observing Figures 11 & 12 from [7]. In Figure 11, the two tendons for each joint are actually in tension. The hysteresis effects noted previously in the Part I testing at the Armstrong Laboratory may be due to slightly different characteristics in the antagonist-agonist pair of actuators in Figure 11. This hysteresis could also be a consequence of a dead zone characteristic in the material used for the tendon (high strength polymeric material). It is noted that the mechanical configuration in Figure 11 with the pulley, allows for both high strength and low friction operation.

The impact of the coupling on dynamic response can easily be seen when one views a bandwidth plot (gain versus frequency where gain refers to the ratio of an output variable such as joint response to an input command consisting of a sine wave) for the three joints. In Figure 12 it is observed that coupling causes a severe degradation in the response of joint

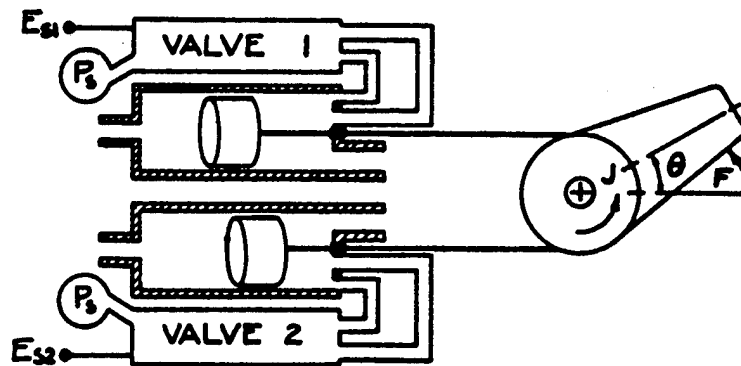

From [7] Each joint is operated by two tendons which are tensioned by actuators consisting of low stiction cylinders and pressure controlling valves.

Figure 11. Pneumatic Actuation System

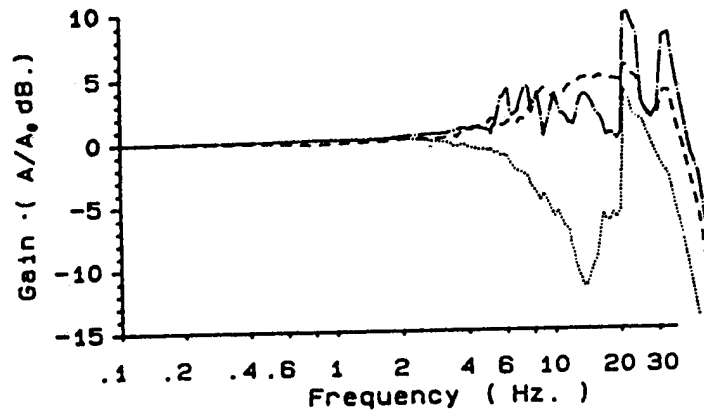

JOINT 1
 JOINT 2 - - - -
 JOINT 3 ———



From [7] Gain plot for an individual finger executing a forward running motion.

Figure 12. Bandwidth Response of the Three Joints

1 at or about 10 Hz. This is also consistent with the data obtained at AL/CFBS in Figure 10 where the coupling transfer function has a resonance at approximately 10 Hz. Thus, for both positioning and bandwidth improvement, a controller needs to be designed to compensate for this coupling.

Controller Design to Mitigate Coupling Effects

The design of a controller follows straight forwardly once the equations of motion of the device in question are derived. In [1] the approach was as follows:

(1) Knowing the Denavitt-Hartenburg transformation matrix describing the forward kinematic properties of this manipulator system, one could calculate the response of joints 2 and 3 when an input is applied only to joint 1. This can be written in vector form:

$$\underline{\Theta} = g(f(t), \Theta_1(t), \underline{\Theta}(t)) \quad (1)$$

where $f(t)$ is the input forcing function into joint 1, $\Theta_1(t)$ describes the position response of joint 1, and the 2×1 dimensional vector $\underline{\Theta}$ describing the position responses of joints 2 and 3

to these variables. If one now applied the negative of the signal in equation (1) to the respective joints, then the resulting signal at that joint should exhibit a value close to zero. This is actually equivalent to feeding back a position error signal where the reference input is zero describing the desired equilibrium point we wish to reach for this controller augmented system for the coupling problem considered herein.

Efficacy of the Controller Solution

The overall system was simulated with and without controller design using the Matrix x Control System package. The first joint was excited with a sinusoidal signal and the second and third joints exhibited responses as depicted by the transfer function matrix in Table II. When the negative error signal was added to the joint commands (as indicated in equation (1), the coupling effects were reduced over 90% [1]. Thus, the efficacy of this procedure was demonstrated. These results are reported in [1].

SUMMARY AND CONCLUSIONS

The control of a very dexterous manipulator, like the UTAH/MIT Dexterous Hand may be an extremely complex process. If a manipulator device is to have properties of dexterity, this may be traded off with the occurrence of nonlinear characteristics such as hysteresis affecting the positioning capabilities of the device. In addition, for the system considered herein, there exists coupling in the form of friction or inertial parameters which are physically a part of the mechanism under analysis. With a simple controller design consisting of the negative of the coupled joint motion fed directly back into the joints that are experiencing undesired motion, substantial reduction of this coupling can be achieved.

REFERENCES

1. M. Adapolli, "Design of a Controller for the UTAH/MIT Dexterous Hand," Master of Science Thesis, Wright State University, Department of Electrical Engineering, Dayton, Ohio, August 1989.
2. S. C. Jacobsen, I. D. McCammon, K. B. Biggers, and R. P. Phillips, "Design of Tactile Sensing Systems For Dexterous Manipulators," IEEE Control Systems Magazine, February 1988, pp. 3-13.
3. J. J. Craig, "Introduction To Robotics," Addison-Wesley Publishing Company, Inc., 1986.
4. C. S. G. Lee, "Robot Arm Kinematics, Dynamics, and Control," Computer, December 1982, pp. 62-79.
5. D. W. Repperger, "Results of A Calibration Study on October 15, 1987, Involving The UTAH/MIT Dexterous Hand," January 1988, Internal Memo.
6. D. W. Repperger, "Transfer Function Measurements of One Finger of The UTAH/MIT Dexterous Hand on January 22, 1988," February 1988, Internal Memo.
7. S. C. Jacobsen, E. K. Iversen, D. F. Knutti, R. T. Johnson, and K. B. Biggers, "Design of the UTAH/MIT Dexterous Hand," Proceedings of the IEEE International Conference on Robotics and Automation, San Francisco, California, April 7-10, 1986, pp. 1520-1531.