

Navy Personnel Research and Development Center

San Diego, California 92152-7250 TN-95-6 August 1995

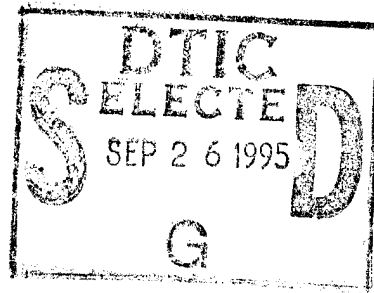

Design and Development of the Paperless Classroom



Barbara A. Morris
Janet Dickieson

19950922 107

DTIC QUALITY INSPECTED 1

Design and Development of the Paperless Classroom

Barbara A. Morris
Janet L. Dickieson

Reviewed by
C. A. Robinson

Accession For	
NTIS CRA&I	<input checked="" type="checkbox"/>
DTIC TAB	<input type="checkbox"/>
Unannounced	<input type="checkbox"/>
Justification	
By	
Distribution /	
Availability Codes	
Dist	Avail and/or Special
A-1	

Approved and released by
J. C. McLachlan
Director, Classroom and Afloat Training

REPORT DOCUMENTATION PAGE

Form Approved
OMB No. 0704-0188

Public reporting burden for this collection of information is estimated to average 1 hour per response, including the time for reviewing instructions, searching existing data sources, gathering and maintaining the data needed, and completing and reviewing the collection of information. Send comments regarding this burden estimate or any other aspect of this collection of information, including suggestions for reducing this burden, to Washington Headquarters Services, Directorate for Information Operations and Reports, 1215 Jefferson Davis Highway, Suite 1204, Arlington, VA 22202-4302, and to the Office of Management and Budget, Paperwork Reduction Project (0704-0188), Washington, DC 20503.

1. AGENCY USE ONLY (<i>Leave blank</i>)		2. REPORT DATE August 1995		3. REPORT TYPE AND DATE COVERED Final FY91-FY94	
4. TITLE AND SUBTITLE Design and Development of the Paperless Classroom				5. FUNDING NUMBERS Program Element: 0602233N Work Unit: RM33T23	
6. AUTHOR(S) Barbara A. Morris, Janet Dickieson					
7. PERFORMING ORGANIZATION NAME(S) AND ADDRESS(ES) Navy Personnel Research and Development Center San Diego, CA 92152-7250				8. PERFORMING ORGANIZATION REPORT NUMBER NPRDC-TN-95-6	
9. SPONSORING/MONITORING AGENCY NAME(S) AND ADDRESS(ES) AEGIS Training Center 5395 First Street Dahlgren, VA 22448-5190				10. SPONSORING/MONITORING AGENCY REPORT NUMBER	
11. SUPPLEMENTARY NOTES Functional Area: Training Systems Technology Product Line: Training Technology Effort: Paperless Classroom					
12a. DISTRIBUTION/AVAILABILITY STATEMENT Approved for public release; distribution is unlimited.				12b. DISTRIBUTION CODE A	
13. ABSTRACT (<i>Maximum 200 words</i>) <p>The Paperless Classroom project explored the use of advanced technology to design, develop, and demonstrate an interface to large amounts of technical information available in electronic form. Instructional materials and graphics were successfully authored and presented as electronic "books." Hypertext principles allowed for improved data retrieval by the instructor and students. Teaching was enhanced by the ability to display and zoom in on graphics as well as to display the images on student workstations. A new instructional environment was created by networking an instructor workstation with 12 student workstations. A prototype system was field-tested at the AEGIS Training Center, Dahlgren, VA.</p> <p>The objective of this report is to document the design and development of the Paperless Classroom system.</p>					
14. SUBJECT TERMS Paperless classroom, instructional technology, electronic instruction, hypertext, lecturing tools, Standard General Markup Language (SGML)				15. NUMBER OF PAGES 36	
				16. PRICE CODE	
17. SECURITY CLASSIFICATION OF REPORT UNCLASSIFIED	18. SECURITY CLASSIFICATION OF THIS PAGE UNCLASSIFIED	19. SECURITY CLASSIFICATION OF ABSTRACT UNCLASSIFIED	20. LIMITATION OF ABSTRACT UNLIMITED		

Foreword

This research and development effort was conducted under the exploratory development program element 0602233N, Personnel and Training Technology (NP2A), project number RM33T23. Sponsors included the Office of Naval Research and AEGIS Training Center. The objective of this project was to develop innovative and effective technologies to increase the efficiency and cost-effectiveness of training. The Paperless Classroom task was initiated in FY91 to explore, develop, and demonstrate an interface to large amounts of technical information available in electronic form. A prototype system was developed and field tested under this task. The objective of this report is to document the design and development of the Paperless Classroom.

J. McLACHLAN
Director, Classroom and Afloat Training

Summary

Problem

Information technology advances are changing the way Navy personnel operate and maintain equipment. Currently, Naval vessels are inundated with paper--mostly technical information and documentation required to support operation and maintenance of the equipment. In training, the problem of dealing with extensive technical documentation is at least as severe. Instructor and student curricular materials contain extensive cross-references to the technical publications and to other training materials or visual aids, such as audio-visual presentations and laboratory exercises. Our research focused on the feasibility of building an interface to this technical information and providing the instructor a tool to facilitate delivery of electronic instructional materials.

Objective

The objective of this project was to explore the use of advanced computer technology to design and develop an interface to technical information in electronic form.

Approach

The AEGIS Fundamentals course (CDP 034Z) was chosen as the first to receive automated instructional materials and student/instructor workstations. Phase I developed and validated one of the central curricular products used during lectures, the electronic Instructor Guide (IG). Phase II installed student workstations, developed the electronic Trainee Guide (TG), and improved the IG. A prototype system was delivered and tested during May 1994.

Results

A paperless classroom system was successfully developed using the most current hardware and software, resulting in an instructor workstation networked with 12 student workstations. The instructional materials and associated graphics were successfully authored and presented as electronic "books." Hypertext principles allowed for improved data retrieval by the instructor and students, and created a new instructional environment.

Conclusions

The Paperless Classroom system proved to be a very useful tool for the instructor to personalize the instructional materials and to access technical information in electronic form. The system was very reliable and easy to use by instructors and students. Teaching has been enhanced by the ability to display and zoom in on graphics as well as to display the images on student workstations. As instructors become more comfortable with the system, the value of having such a tool for course development and presentation will be more fully realized. Potential benefits of an electronic classroom are increased instructor and student productivity, better use of the physical plant (e.g., classrooms), easier integration of revised training materials, and printing and publishing cost savings.

Recommendations

It is recommended that the AEGIS Training Center:

- Consider additional courses for automation.
- Provide structured training for instructors who teach in automated classrooms.
- Link the Paperless Classroom to laboratory systems or other classrooms.
- Convert from Unix to a Windows product for PC computers.
- Enhance the present system with other modules.

It is recommended that system developers:

- Clearly define project requirements.
- Identify constraints early.

Contents

	Page
Introduction.....	1
Problem.....	1
Objective.....	1
Background.....	1
Related Studies.....	2
Approach.....	4
Course Selection.....	4
Compliance With Standards.....	4
Hardware and Software Selection.....	5
User Interface Design.....	5
Results.....	6
Course Selection.....	6
Compliance With Standards.....	6
Hardware and Software Selection.....	6
User Interface Design.....	9
General Design.....	11
Conclusions.....	13
Lessons Learned.....	13
Recommendations.....	14
References.....	17
Appendix A--Sample Instruction Sheets.....	A-0
Appendix B--Sample Graphics.....	B-0
Distribution List	

List of Figures

	Page
1. Hardware configuration.....	7
2. Software configuration.....	10
3. Screen display of instructor guide.....	12
4. Student classroom	13

Introduction

Problem

Information technology advances are changing the way Navy personnel operate and maintain equipment. Currently, Naval vessels are inundated with paper--mostly technical information and documentation required to support operation and maintenance of the equipment. For example, an AEGIS cruiser is said to ride seven feet lower in the water because of the paper on board. Sailors of the future will use Interactive Electronic Technical Manuals (IETMs) onboard ship. Major programs, such as Continuous Acquisition and Life-cycle Support (CALs), and the "Paperless Ship" initiative are addressing the electronic technical manual problem. Before they can use IETMs, Navy schoolhouses must incorporate them into their training curricula.

In training, the problem of dealing with extensive technical documentation is at least as severe. Instructor and student curriculum contain extensive cross-references to the technical publications and to other training materials or visual aids, such as audio-visual presentations and laboratory exercises. Our research focused on the feasibility of building an interface to this technical information and providing the instructor a tool to facilitate delivery of electronic instructional materials, while allowing for the eventual availability of IETMs.

Objective

The objective of this project was to explore the use of advanced computer technology to design and develop: (1) an electronic form of the Instructor Guide (IG), (2) a set of tools, which permit the instructors to electronically personalize the IG, (3) a presentation interface to the electronic IG, (4) an electronic technical publication interface, (5) a student workstation/interface; and (6) an electronic form of the Trainee Guide (TG).

Background

The Navy Personnel Research and Development Center (NPRDC) began working with the AEGIS Training Center during FY91 to develop an automated classroom. The NPRDC exploratory development project, Paperless Classroom, soon became part of the larger AEGIS Classroom of the Future effort. These projects are addressing issues associated with military downsizing and less available funding. Emphasis is placed on reviewing training methods and considering networking classrooms, laboratories, and remote sites to more efficiently use available resources.

During FY92, NPRDC was completing development of an automated system for paper-based curriculum preparation and maintenance, called Authoring Instructional Materials (AIM). AIM is now being widely distributed to Navy sites by an OPNAV Program Office in N7. The AEGIS Training Center was a member of the AIM Management Team, serving to oversee development of the system software. The AEGIS Training Center also served as a test site for AIM.

AIM uses a relational database to store course information so that the development and revision of training materials can be accomplished most efficiently. The AIM relational database provides cross-referencing to elements within the course and an audit trail for training requirements.

Because AIM provides a digitized version of instructional materials, it made logical sense to use AIM for the initial Paperless Classroom course development.

Technical training is presented in the IG and TG, which are paper-based documents containing several hundred pages. In addition, for even a short course, there may be large numbers of drawings, schematics, and tables. The IG is a detailed outline of instruction made up of discussion points with references to supporting technical publications and training aids, from which the instructor lectures. It is the instructor's responsibility to "personalize" the IG by including detailed information about each of the discussion points. The instructor may use films, transparencies, handouts, or technical manuals to illustrate discussion points during lecture. The TG contains Instruction Sheets, as presented in Appendix A, which provide students with more in-depth information about the topics discussed by the instructor. The TG may include several types of Instruction Sheets: Information, Diagram, and Problem. The Information Sheet, much like a book chapter, provides relevant information about a topic. Often a Diagram Sheet follows the Information Sheet to illustrate a topic. After students read the Information Sheet and study the Diagram, a Problem Sheet may follow to further increase understanding of the material.

Phase I developed and validated the electronic IG. A prototype system was delivered and tested during December 1992. Phase II installed student workstations, developed the electronic TG, and improved the IG. An enhanced prototype system was delivered and tested during May 1994. Paperless Classroom evaluation reports (Morris, 1993 & 1995) discuss the results of Phase I and II observations, surveys, and other methods of data collection.

Lessons learned from the design and development of the Paperless Classroom prototype system provided the basis for Classroom Automation, an advanced development follow-on project funded by the Office of Naval Research (ONR) and sponsored by the Chief of Naval Education and Training (CNET).

Related Studies

Designing a system for the Paperless Classroom required that we consider many important issues. A review of related research studies was conducted. Of particular interest were those related to designing an electronic classroom, presenting text and graphics on a computer system, learner control and guidance provided by the system, and how new lecturing tools can impact the classroom environment.

Norman (1990) discussed the need for a more integrated approach to developing an electronic classroom. He states that an interface should be built to facilitate the application of hypermedia by looking at instructional interaction among students, instructors, and the course material. From a basic model of this interaction, the designer then explores innovative technologies to support a wide range of instructional and classroom activities.

Kozma (1991) described the process of a student actively collaborating with a medium to construct knowledge as opposed to learning resulting from the instruction being "delivered" by some medium. Computers, for example, have the capability of creating a dynamic learning environment by connecting text, graphical representations, sound, and video to the real world

phenomena they represent. Students can manipulate these representations on the computer to perform procedures, solve problems, and improve their comprehension of the material.

The way in which text is represented on a computer affects how it can be used by the writer and the user. DeRose, Durand, Mylonas, and Renear (1990) state that the electronic document model has been lacking sophistication and sees emerging standards such as Standard Generalized Markup Language (SGML) a step in the right direction. Today's computer user wants portability, compatibility, easier retrieval of information, composition assistance tools, data sharing capability across platforms and applications, and hypertext documents. Hypertext, a term coined in the early sixties, is a method for presenting text on a computer in a non-linear manner (Smith, 1988; Tsai, 1988). The learner is presented with an established database, structured by the author, and is free to navigate the document as he/she wishes. Navigation techniques facilitate this environment as users proceed from one screen to another, call up windows to link to animation, a word processor, other software packages, or graphics.

Nielsen (1990) discussed navigation aids and screen design to create a dynamic learning environment. He concluded that hypertext can be very useful for many applications, but one problem to be solved has to do with the spatial display of information. He refers to the problem as "context-in-the-small." One solution he offers is to use larger computer screens to display schematic drawings and flowcharts, which would not be readily understood if they were split across screens.

A system designer should maintain consistent functional areas on the computer screen. This makes it easier for users to transition from one instructional unit to another, allowing them to focus on the subject matter rather than the medium being used (Heines, 1984). Orientation information is another important aspect to the display of text on a computer. Students want to know how far they have worked through the material. The computer program can track and display the current module and lesson name as students work through the lesson.

Wadlow (1990) developed a set of interface guidelines for the Andrew system, which is used by developers to build multimedia application programs. Consistency was a primary concern as the interface guidelines were developed for Andrew. The developers attempted to maintain consistency in the kinds of objects users saw on the screen, in kinds of operations possible within applications, as well as in methods used to pass information from user to machine and back. Other factors included predictability of responses from the system, locus of control placed on the user, visual appeal of screen layout, and a sense of the user manipulating "real" objects on the screen. Real objects may be buttons, menus, switches, data entry fields, or dialog boxes.

As we develop an electronic curriculum delivery system, we must consider the role of instructor. Bell and Elmquist (1992) stress the importance of encouraging instructors to use new technological innovations. By doing so, they will broaden their capabilities and have a real impact on the classroom of the future. They see technology as not replacing the instructor but providing a means for instructors to reform education. Eisner and Carter (1989) believe instructors face new challenges as their roles change to instructional designer/author and provider of learning resources. With lecturing facilities rapidly changing, instructors often feel the lack of support, equipment, and time to adjust to these changes. Presenting instructors with new lecturing methods can have a serious impact on their activities. Instructors should be included in the planning and

implementation of new technology, and should be given the necessary time and resources to learn how to best use these new methods. Sammons (1994) describes ways to motivate instructors to become involved in using multimedia lecturing tools. Important motivating strategies are: make equipment available, provide time for instructors to develop materials, provide support, and provide easy-to-use hardware and software.

Gist, Lorenzen, Swanson, McQuade, and Fuller (1989) discuss the development of a computer controlled instructor workstation for the Air Force Academy. Their goal was to develop a system that instructors could use, regardless of their experience with computers, to benefit classroom instruction. The system design requirements were ease of use, independence of pedagogy, flexibility, maintainability, adequacy of support systems, and utility or benefit to the educational process. They found that these design requirements led to an effective and useful system that can significantly enhance the use of computers in the classroom.

Apple Classrooms of Tomorrow (ACOT) is one example of a technology-rich environment for elementary through high school students to explore (Knapp, 1989). Instructors were encouraged to develop new lesson materials and methods of instruction to make use of the technology available. Two kinds of network-supported learning environments, self-paced and project-based, were established. The network system enabled instructors and students to share information, access information from multiple sources, link to a variety of storage devices, and communicate personally with others.

Lecturing technologies are rapidly developing and changing the way instructional materials are presented in the classroom. Lennon and Maurer (1994) see a single system in the future that integrates multimedia presentations, computer-assisted learning, computer conferencing, distance learning, and decision rooms. This single system will be the most powerful educational tool ever known.

Approach

Course Selection

Originally, the Prospective Commanding Officer/Prospective Executive Officer (PCO/PXO) course was selected for development during 1992 and the Fundamentals course for development during 1993. After we observed the PCO/PXO course, it became clear that it would be best to develop a prototype system using an unclassified course, with structured materials and higher student throughput. The decision was made to drop the PCO/PXO course and begin work with the Fundamentals course (CDP 034Z).

Compliance With Standards

In an effort to explore ways of applying advanced technology to make the process of personalizing and delivering a course more efficient, NPRDC chose to work with the electronic book concept. Applicable government initiatives, such as CALS and Paperless Ship, and the MIL-M-28001 standard were followed as the system design was formulated.

Hardware and Software Selection

A market survey was conducted of current hardware and software products to support our design. An evaluation of available peripheral equipment such as large screen monitors and projection systems, light pens, and remote control devices was completed by attending trade shows, inviting demos by vendors, talking to others who have used them, and reading trade journals.

User Interface Design

The Paperless Classroom system IS the user interface product. Our design philosophy was:

- The interface should be designed for the user and not constrained because of the software or challenge for the developer. Instructors and students are the users. It is important to obtain their feedback throughout system development.
- Identify expected "typical" users. This was accomplished by interacting with instructors and students.
- Create a design process to accommodate users' needs. Instructors provided suggestions for system development by describing how they lectured from paper-based instructional materials.
- Establish an interdisciplinary design team. The design team consisted of computer specialists, programmers, and instructional designers.
- Support building a modular, layered system design, which allows changes to the interface.
- Design interface to be the part of the system most open to change.

Once the course, equipment, and software products were selected, these steps were followed to develop the interface:

- Conduct a task analysis with users.
- Follow iterative process to gradually try design ideas with users.
- Include appropriate data hooks between text and graphics.
- Test prototype interface with users.
- Analyze users' subjective feedback and objective data.
- Redesign prototype interface to meet users' requirements and needs.
- Fine tune design by continuing to collect user's feedback on interface modifications.
- Observe interface performance in a real world setting.
- Use findings to apply to development of another system.

Results

Course Selection

Fundamentals, a two week course taught at the AEGIS Training Center, Dahlgren, VA, prepares students for advanced training in computer architecture. Students attend the AEGIS Weapons System (AWS), SPY Radar, Fire Control System/Operational Readiness Test System (FCS/ORTS), Display or Computer courses as follow-on to this course. Fundamentals is primarily an introductory course in digital circuits and computer system architecture. Over 400 printed pages for the IG, approximately 500 printed pages for the TG, and links to 200 transparencies of schematics, drawings, and tables were generated by AIM.

Compliance With Standards

The Paperless Classroom course was compliant with the Continuous Acquisition and Life-cycle Support (CALs) initiative by using Standard Generalized Markup Language (SGML) and compatible electronic book publishing software during development. CALs is a Department of Defense (DoD) strategy that will enable more effective creation, exchange and use of digital data. The goal of CALs is to establish an infrastructure within DoD to create, receive, store, and manage digital technical data with the notion that data will be created only once but could be shared for many uses.

SGML, an internationally accepted standard for electronic publishing, is an accepted CALs standard for text data exchange. SGML defines a document in terms of its hierarchical structure. It does not directly specify how to format or process a document, but describes the structure with "tags" that are given for content objects of the data. This method is very useful for storing and retrieving data as prescribed by the CALs strategy. Text processing systems are most useful for composition and production assistance, and facilitation of alternate uses for data. These are exactly the reasons we chose to use SGML to "tag" data to be presented on the Paperless Classroom system.

Hardware and Software Selection

A market survey was conducted of current hardware and software products to support our design. The Unix operating system was considered to be the optimal choice. Unix workstations provided tools, networking capability, and an environment well suited for this type of development. Additionally, it was important to be compatible with AIM and to use a CALs-compliant electronic book software. Figure 1 provides the hardware configuration.

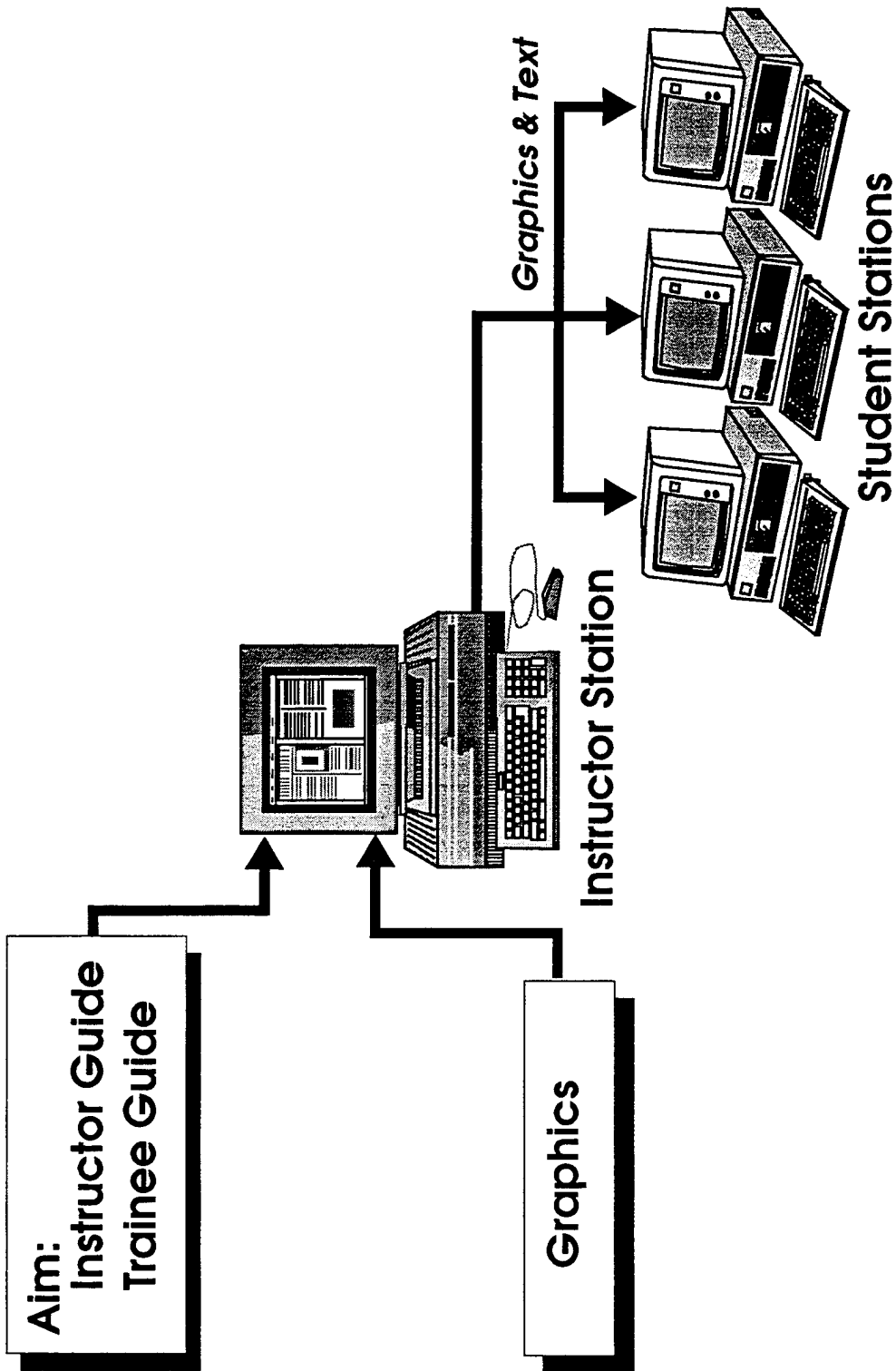

Figure 1. Hardware configuration.

Given the design criteria mentioned above, the resulting hardware configuration consisted of:

One Instructor Workstation

Sun SparcStation 10
64 Mb RAM
two 424 Mb Hard Disks
two 16" Color VGA Monitors, 1152 x 900 pixels resolution
track ball and mouse

Twelve Student Workstations

Sun SparcStation LX
24 Mb RAM
one 424 Mb Hard Disk
16" Color VGA Monitor, 1152 x 900 pixels resolution
one mouse

A Local Area Network (LAN) connection to link instructor and student workstations

It was found that none of the available large screen projection systems provided the high resolution needed to display the very detailed schematic drawings. Another factor, the preference for lighting to be ON in the classroom, caused too much glare on the large screens. Instructors asked for the IG to be displayed on monitors in the back of the room and light pens to change discussion points. These items were investigated but not incorporated in the classroom.

Commercial off-the-shelf software was used for most of the development. Exceptions to this were the use of AIM, text conversion, and networking software developed by NPRDC. Table 1 lists the software products required for development of the electronic book.

Table 1

Software Products Selected

Product	Source
AIM	Navy
Conversion Troff to SGML	Navy
DynaText	Electronic Book Technologies, Inc.
CorelDraw	Corel Systems Corp.
CADleaf Plus	Carberry Technology, Inc.
FrameMaker	Frame Technology Corp.
ArborText	Arbor Text Inc.

CorelDraw (graphics development program), CADleaf Plus (graphics conversion and viewing program), and DynaText (electronic book publishing program) were selected for this effort, because in combination they delivered the required viewing capabilities for text and graphics. DynaText features such as automatic tagging, complex table support, dynamic table of contents,

multiple style sheets, interface to AIM, full text indexing, and support for large documents made this the best available program for our system development. Curriculum changes made in AIM could be easily incorporated into the electronic formats by using DynaText. These products support industry standards and allowed NPRDC to maintain CALS compliance.

As shown in Figure 2, authoring the IG and TG in AIM (Oracle database) was the first step. Second, the IG/TG data were exported from AIM and converted to SGML (by a program written by NPRDC). The electronic book was completed and the instructor added personalization to the instructional materials using DynaText. Graphics were created using CorelDraw and saved in Computer Graphics Metafile (CGM) vector format. Having the graphics in vector format enabled users to zoom in or out on a detailed graphic. The two conversions, Encapsulated PostScript (EPS) and CGM, allowed the curriculum developers to meet a requirement for a printed course from AIM and an automated course from DynaText. The graphics had to be identified in AIM because the file information was stored in the database. This step was essential for Dynatext to make use of the data. See Appendix B for examples of the graphics displayed during this course.

User Interface Design

The off-the-shelf version of DynaText provided 90% of the required functionality. The DynaText library of nearly 300 functions in the Systems Integrator Toolkit allowed NPRDC software developers to program the rest.

Personalization. The process of annotating the IG is known as “personalization.” The IG is a basic outline, covering discussion points and related activities, that must be supplemented by the instructor's in-line annotations. As instructors prepare their lectures for a paper-based course, they are typically given several large binders containing the IG. The course content must be completed by the instructors who insert handwritten annotations, or “notes,” into the IG. Instructors teaching the Fundamentals course reported it took them as long as three weeks to personalize the IG. This was a substantial amount of time given the course is only two weeks long. As a newer version of the IG became available, instructors copied the personalization into the new IG, which took at least another week. The Paperless Classroom system provided instructors a tool for personalizing their lecture materials more efficiently. Personalization from one course revision to the next was saved in the database by software links to unchanged discussion points. The result was that there was no longer a need to copy annotations again and again as with printed materials.

Two major modifications to the system were made to accommodate personalization: (1) the format of annotations or notes instructors made to the IG and (2) the capability to use graphics as annotations, which is not standard for electronic books.

Formatting annotations or notes. The standard method for adding annotations in the electronic book is with an editor window opening in which the author enters text. The window is closed by the instructor and the text is saved. An icon is positioned at the appropriate place in the document to indicate that an annotation is present. For this course, the instructors made notes for almost every discussion point. It was clear that opening a window to display a note every few lines would be very inconvenient. The Electronic Book Technologies (EBT) programmers modified DynaText to give the instructors something closer to what they had on paper, with the note appearing “in-line” beneath each discussion point. The instructor still puts text in an editor window,

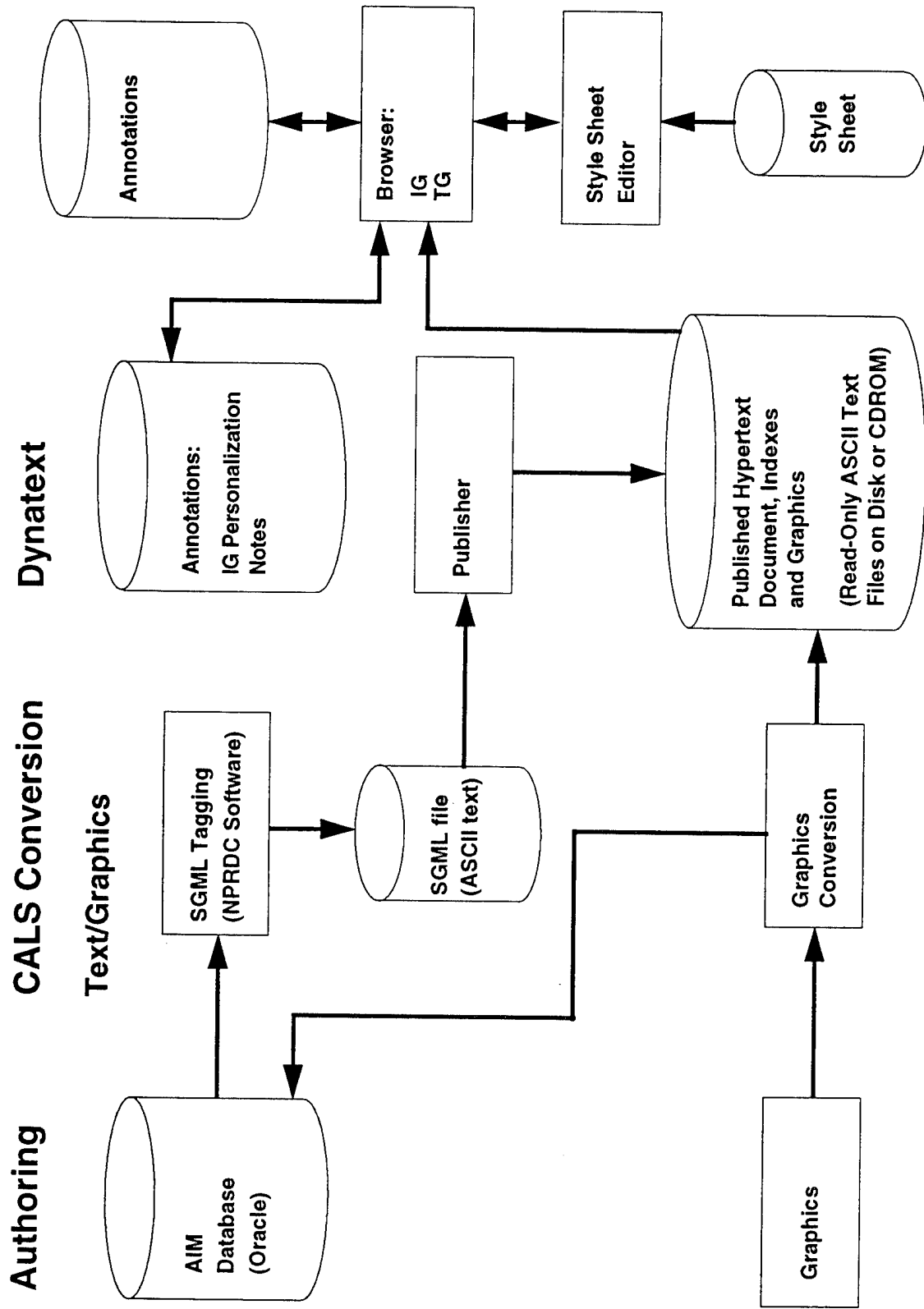

Figure 2. Software configuration.

but when the text is saved it is rendered in order directly in the document. One nice feature is that the outline is displayed in a different color from the annotations, making it easier for the instructor to see the annotations during lecture.

Capability to use graphics as annotations. The second modification was the capability to use graphics as annotations, which is not standard for electronic books. NPRDC customized DynaText to give instructors the ability to have more than one graphic linked with each annotation. Clicking on one icon can display several graphics. The instructor can also move, size, or zoom in and out on the graphics. Related work by Frey, Rouse, and Garris (1992) and Frey (1994) provided guidelines for displaying graphics on a computer monitor.

General Design

The user interface design was an iterative process. As instructors used the system, they provided designers with additional feedback. The result is a system with pull down menus, scroll bars for navigating through the document, annotation icons that are linked to text or graphic files, and a table of contents for easy navigation to topics, tables, and graphics. The IG is displayed in landscape format, as shown in Figure 3, much like it looks on paper. The notion was to develop the automated course in a "book" format. It was thought that the instructors and students could assimilate the information presented by a different media faster when they encounter a familiar format. With the electronic book format, we added another dimension of searching and non-linear navigation of the information. The search function allows the user to search through the document by keywords or phrases.

The sequence of information in the course was predetermined by curriculum developers using AIM. Instructors were given control over what they wanted to display to the students as they lectured. Student workstations were networked with the instructor workstation. NPRDC programmed the interface that allowed the instructor to send graphics to the student workstation. This replaced the need for an overhead transparency projector. The instructor could also release the control and allow students to navigate freely through the document during study periods.

The student workstation, as shown in Figure 4, has a retractable shelf for the keyboard and mouse. The monitor is below the desk surface, under a smoked glass top. The desk ergonomics allowed for good visibility across the room and eye contact between students and the instructor. The instructor workstation consisted of two computer monitors, one displayed the IG and the TG was displayed on the other. The instructor accessed the IG and TG with the keyboard, a mouse, or trackball.

- S-150-0240 AEGIS Fundamental
 - Front Matter
 - A002 Basic Electricity
 - T0007 Digital Systems
 - T0010 AEGIS Combat System
 - Back Matter

DISCUSSION POINT RELATED INSTRUCTION ACTIVITY

TOOLS

2. Digital Circuit Components

a. Gate Functions

a. Refer to Information T0007-1-1-2, paragraph 1.0.

(1)  Inverter
This is an example of inline

(2) AND

(2) Refer trainee to Information Sheet T0007-1-1-2, figure 1-2.

Search:

Figure 3. Screen display of instructor guide.

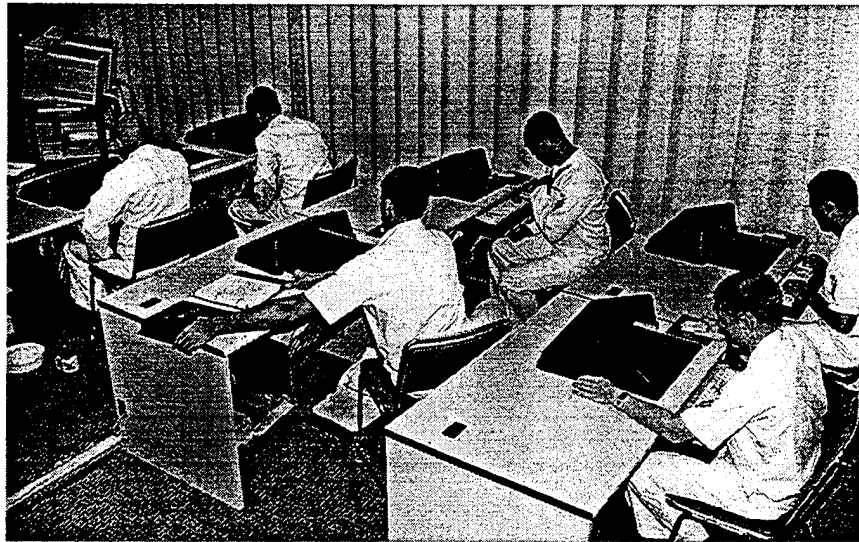

Figure 4. Student classroom.

Conclusions

Advances in technology have combined media so that information previously delivered by several devices is now integrated into one device. Computers play a central role in this environment. Text is displayed in one window and visuals such as graphics or video are displayed in another window. There is a collaboration between the user and the computer. As the computer processes information, the user makes navigation decisions and subsequent selections. With a collaborative environment in mind, the Paperless Classroom system was developed with the intent to improve delivery of technical information by using the latest technology. The Paperless Classroom system has been successful as a first attempt to provide instructors and students with a product useful for developing and displaying technical training materials in the classroom. Potential benefits of an electronic classroom are increased instructor and student productivity, better use of the physical plant (e.g., classrooms and laboratories), easier integration of revised training materials, and printing and publishing cost avoidance.

Lessons Learned

The Paperless Classroom research project was conducted under the Navy's "exploratory development" program. As such, we set out to design and develop a prototype system using the latest advances in technology. The nature of this type of work is to explore new products that will be useful for project development. We soon learned that different versions of a software product are not necessarily compatible. When this effort began, some of the software products were not very "mature" and we were basically testing the software. As a user, that is very frustrating and disconcerting when you are trying to produce a product in a timely manner. It took about a year to complete the process of authoring, revising, and converting the graphics to get them in a good form for computer display. From our experiences with various software packages, we learned that

“conversion” of graphics and text takes a major amount of effort, is costly, and very time consuming.

To implement graphics into the electronic book for the AEGIS Fundamental Course, the graphics were required to be in CGM format. At the start of this project CorelDraw was the only package supporting CGM. All of the original graphics were created with CorelDraw version 2.0 by a contractor. NPRDC purchased CorelDraw version 4.0 and later found incompatibilities between version 2.0 and 4.0. All of the graphics had to be modified. Developers chose to use FrameMaker to revise and size the graphics since AEGIS personnel were very experienced with FrameMaker and controlled course development and maintenance. The result was additional time consuming and tedious steps during the conversion process.

Another important issue is how to handle legacy data. In the past, instructional materials were developed using various word processing programs. Many of the major software companies are addressing the conversion of legacy data from a word processing format to SGML, but we did not find a suitable product. One alternative is to use an SGML editor and compatible graphics packages to re-author the materials. It is expensive to purchase the new software and to train authors and editors. Another alternative is to scan the text and graphics, but this often results in a product of lower quality. Because of the expense associated with handling legacy data, developers end up with two systems, the old and the new. Legacy data may be stored and retrieved as always done in the past and new technology will be used to handle present data. For the Paperless Classroom system, we chose to use the Navy tool, AIM, for developing the training materials. Customized software was developed by NPRDC to extract data from AIM (Unix Troff format) and convert it to SGML. This was an iterative process because we discovered complications with formatting tables, figures, and equations. At the same time this customized software was being written, the AEGIS curriculum developer was completing the authoring process in AIM. Neither the Instructor or Trainee Guides had been completed in AIM before this effort started.

Other problems resulted because of software products supporting different fonts and character representations. For instance, special characters, even common ones such as those required for equations, electrical and math symbols were not supported across the various software products. Many hours were spent locating the fonts and character sets, and adjusting the spacing and placement of these special characters.

Recommendations

It is recommended that the AEGIS Training Center:

- Consider additional courses for automation.

Additional courses should be automated to accommodate the Interactive Electronic Technical Manuals now being developed for fleet as well as classroom training.

- Provide structured training for instructors who teach in automated classrooms.

In the future electronic classrooms will become more prevalent. Instructors need to be prepared to teach using state-of-the-art facilities. One possible solution is to include training specific to this domain in the required Instructor Training course they now attend.

- Link the Paperless Classroom to laboratory systems or other classrooms.
- This capability will free laboratory space. Students would access laboratory exercises remotely from the classroom. Thus, others could use the laboratory spaces simultaneously. Networking other classrooms would provide for many students to be receiving the same instruction from one source.
- Convert from Unix to a Windows product for PC computers.

PC computers are now advanced enough to support sophisticated memory intensive programs. These computers are less expensive and more familiar to the average user.

- Enhance the present system with other modules.

Such enhancements could include a student administration and testing module, and annotation capability for student note taking.

It is recommended that system developers:

- **Clearly define project requirements**

Make it as clear as possible to developers what the required formats are for graphics and text to be compatible with the system being developed. The graphics developer should understand that certain fonts, sizing, type of graphics, etc. are necessary for compatibility with software for product development. Be consistent with font style, character size, line width on drawings, use of color, and button or icon representation. Use good quality control procedures throughout project development.

- **Identify constraints early**

One major constraint during this project development was the need for both paper-based and electronic training materials. Because of the authoring environment, there were many conversion steps required for the proper output. This resulted in two databases to maintain, which will present a problem in the future when changes are made to the training materials. Ensure that all software packages are fully compatible with each other and with the hardware operating system.

References

- Bell, T. H. & Elmquist, D. L. (1992, March). Technical interaction in the classroom. *Vocational Education Journal*, 22-24.
- Eisner, J., & Carter, T. (1989). University faculty teaching activities in an electronic curriculum. *Educational Technology*, 29(4), 17-22.
- DeRose, S. J., Durand, D. G., Mylonas, E., Renear, A. H. (1990). What is text, really? *Journal of Computing in Higher Education*, 1(2), 3-26.
- Frey, P. R. (1994). *Displaying computer graphics and text in the paperless classroom*. Norcross, GA: Search Technology.
- Frey, P. R., Rouse, W. B., & Garris, R. D. (1992). Big graphics and little screens: Designing graphical displays for maintenance tasks. *IEEE Transactions on Systems, Man, and Cybernetics*, 22(1), 10-20.
- Gist, T. E., Lorenzen, G. L., Swanson, R. E., McQuade, M. K., & Fuller, R. G. (1989). The Air Force Academy instructor workstation (IWS): I. Design and implementation. *Journal of Educational Technology Systems*, 17(4), 273-284.
- Heines, J. M. (1984). *Screen design strategies for computer-assisted instruction*. Bedford, MA: Digital Equipment Corporation.
- Knapp, L. (1989). *ACOT classroom networks: Today and tomorrow*. Cupertino, CA: Apple Computer, Inc.
- Kozma, R. B. (1991). Learning with media. *Review of Educational Research*, 61(2), 179-211.
- Lennon, J. & Maurer, H. (1994, April). Lecturing technology: A future with hypermedia. *Educational Technology*, 5-14.
- Morris, B. A. (1995). *Evaluation of the Paperless Classroom (NPRDC-TR-95-7)*. San Diego, CA: Navy Personnel Research and Development Center.
- Morris, B. A. (1993). *Paperless Classroom (Interim Letter Evaluation Report)*. San Diego, CA: Navy Personnel Research and Development Center.
- Nielsen, J. (1990). Through Hypertext. *Communications of the ACM*, 33(3), 297-309.
- Norman, K. L. (1990). The electronic teaching theater: Interactive hypermedia and mental models of the classroom. *Current Psychology: Research & Review*, 9(2), 141-161.
- Sammons, M. C. (1994, February). Motivating faculty to use multimedia as a lecture tool. *T.H.E. Journal*, 88-90.

- Smith, K. E. (1988). Hypertext--Linking to the future. *ONLINE*, 12(2), 32-40.
- Tsai, C. (1988). Hypertext: Technology, applications, and research issues. *Journal of Educational Technology Systems*, 17(1), 3-15.
- Wadlow, M. G. (1990). The Andrew System: The role of human interface guidelines in the design of multimedia applications. *Current Psychology: Research & Reviews*, 9(2), 181-191.

Appendix A
Sample Instruction Sheets

PROBLEM SHEET T0007-1-1-1

NUMBER SYSTEM CONVERSION

A. INTRODUCTION

This problem sheet is provided to assist you in reviewing and increasing your understanding of the fundamentals of number systems.

B. REFERENCES

1. Mano, M. Morris, Computer System Architecture
2. NAVEDTRA 172-13-00-86, Introduction to Number Systems, Boolean Algebra and Logic Circuits

C. PROBLEM

The computers in AEGIS, like all computers, are binary machines; but references to numbers are usually in octal, decimal, or hexadecimal, rather than binary. For example: $00010000_2 = 20_8 = 10_{16}$

Using prescribed methods, perform the conversions listed below:

1. Count in hexadecimal from 0 to 30_{10} .

_____	_____	_____
_____	_____	_____
_____	_____	_____
_____	_____	_____
_____	_____	_____
_____	_____	_____
_____	_____	_____
_____	_____	_____

2. Convert the following numbers from base 10 to base 16.
 - a. 2096
 - b. 1024
 - c. 100
 - d. 86

3. Convert the following numbers from hexadecimal to decimal.
 - a. 2000
 - b. AFDC
 - c. 1024
 - d. FFFF
 - e. 10000

4. Convert the following numbers from octal to hexadecimal.
 - a. 3456
 - b. 1001010

- c. 7777
 - d. 36
 - e. 5
5. Convert the following numbers from hexadecimal to octal.
- a. 4FE9
 - b. 7
 - c. 8
 - d. FFFF
 - e. A
 - f. C010

TABLE 1-1. Truth Table for Full-Adder

Inputs			Outputs	
x	y	z	C	S
0	0	0	0	0
0	0	1	0	1
0	1	0	0	1
0	1	1	1	0
1	0	0	0	1
1	0	1	1	0
1	1	0	1	0
1	1	1	1	1

Figure 1-4 Maps for full-adder.

1.2.2 The maps of Figure 1-4 are used to find algebraic expressions for each of the output variables. The 1's in the squares for the maps of S and C are determined directly from the minterms in the truth table. The squares with 1's for the S output do not combine in groups of adjacent squares. But since the output is 1 when an odd number of inputs are 1, S is an odd function, and represents the exclusive OR relation of the variables (see the discussion at Section 1.0.12). The squares with 1's for the C output may be combined in a variety of ways. One possible expression for C is:

$$C = xy + (x'y + xy'z)$$

Realizing that $x'y + xy' = x$ exclusively ORed with y, and including the expression for output S, we obtain the two functions for the full-adder:

$$S = x \text{ exclusively ORed with } y \text{ exclusively ORed with } z$$

$$C = xy + (x \text{ exclusively ORed with } y)z$$

1.2.3 The logic diagram for the full-adder is drawn in Figure 1-5(a). Note that the full-adder circuit consists of two half-adders and an OR gate.

Figure 1-5 Full-adder circuit.

1.2.4 The full-adder circuit is the most basic digital function for generating arithmetic operations in digital computers. When used in subsequent chapters, the full-adder circuit will be designated by a block diagram symbol as shown in Figure 1-5(b).

7.2.1 The microprogram listed in Table 7-2 specifies the word content of the control memory. When a ROM is used for the control memory, the microprogram binary list provides the truth table for fabricating the unit. This fabrication is a hardware process and consists of creating a mask for the ROM so as to produce the 1's and 0's for each word. The bits of ROM are fixed once the links are fused during the hardware production. The ROM is made of IC packages that can be removed if necessary and replaced by other packages. To modify the instruction set of the computer, it is necessary to generate a new microprogram and mask a new ROM. The old one can be removed and the new one inserted in its place.

Table 7-2. Binary Microprogram for Control Memory (Partial)

Micro Routine	Address		Micro-ops	Microinstruction			Micro-operations and Next Address
	Decimal	Binary		CD	BR	ADF	
ADD	0	0000000	000000000	01	01	1000011	If I = 1 go to 67, SBR ← 1 If I = 0 go to 1
	1	0000001	000100000	00	00	0000010	MBR ← M, go to 2
	2	0000010	001000000	00	00	1000000	AC ← AC + MBR, go to 64
BRANCH	3	0000011	000000000	00	00	1000000	Nothing, go to 64
	4	0000100	000000000	10	00	0000110	If AC(S) = 1 go to 6 If AC(S) = 0 go to 5
	5	0000101	000000000	00	00	1000000	Go to 64
	6	0000110	000000000	01	01	1000011	If I = 1 go to 67, SBR ← 7 If I = 0 go to 7
STORE	7	0000111	000000110	00	00	1000000	PC ← MBR (AD), go to 64
	8	0001000	000000000	01	01	1000011	If I = 1 go to 67, SBR ← 9 If I = 0 go to 9
	9	0001001	000101000	00	00	0001010	MBR ← AC, go to 10
	10	0001010	111000000	00	00	1000000	M ← MBR, go to 64

FETCH	64	1000000	110000000	00	00	1000001	MAR ← PC, go to 65
	65	1000001	000100101	00	00	1000010	MBR ← M, PC ← PC + 1, go to 66

DIAGRAM SHEET T0007-2-1-4

ATES FUNCTIONS

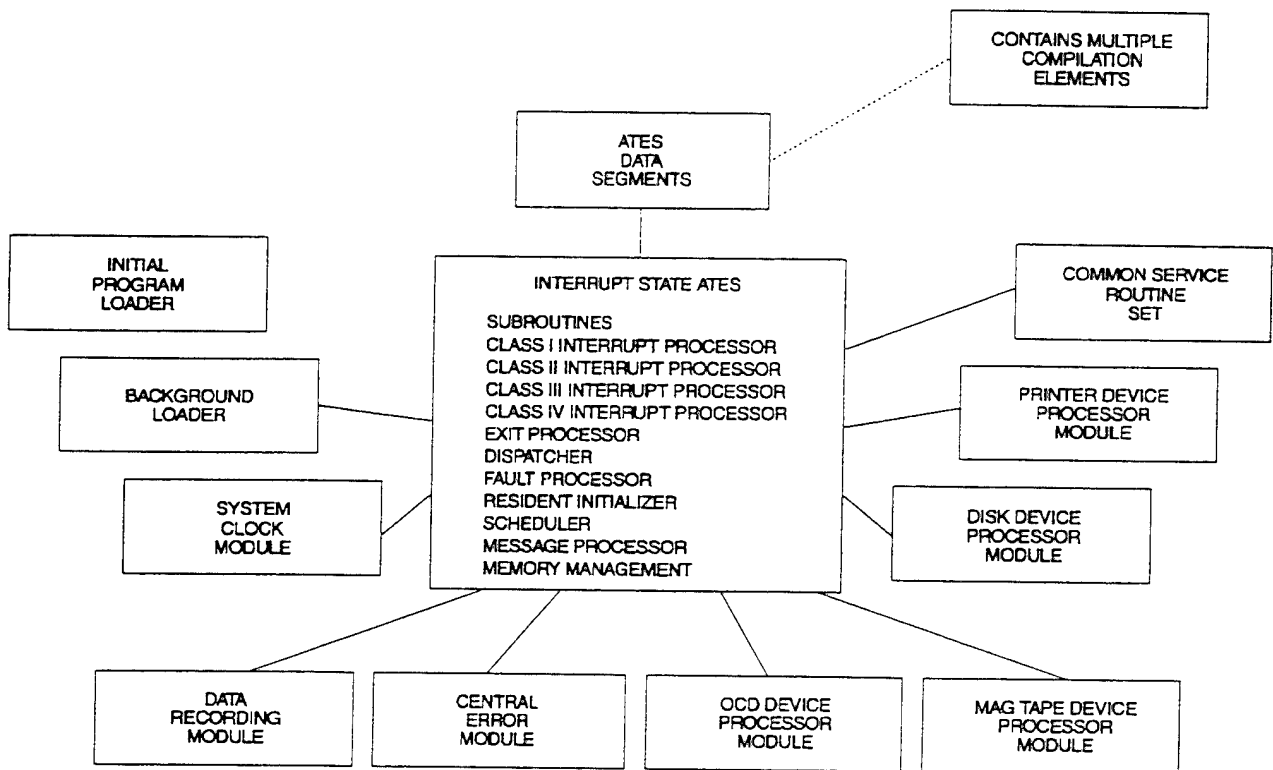

NOTE:
THE "INITIAL PROGRAM LOADER" IS A STAND-ALONE COMPONENT OF ATES AND OPERATES WITHOUT THE SUPPORT OF ATES.

Appendix B
Sample Graphics

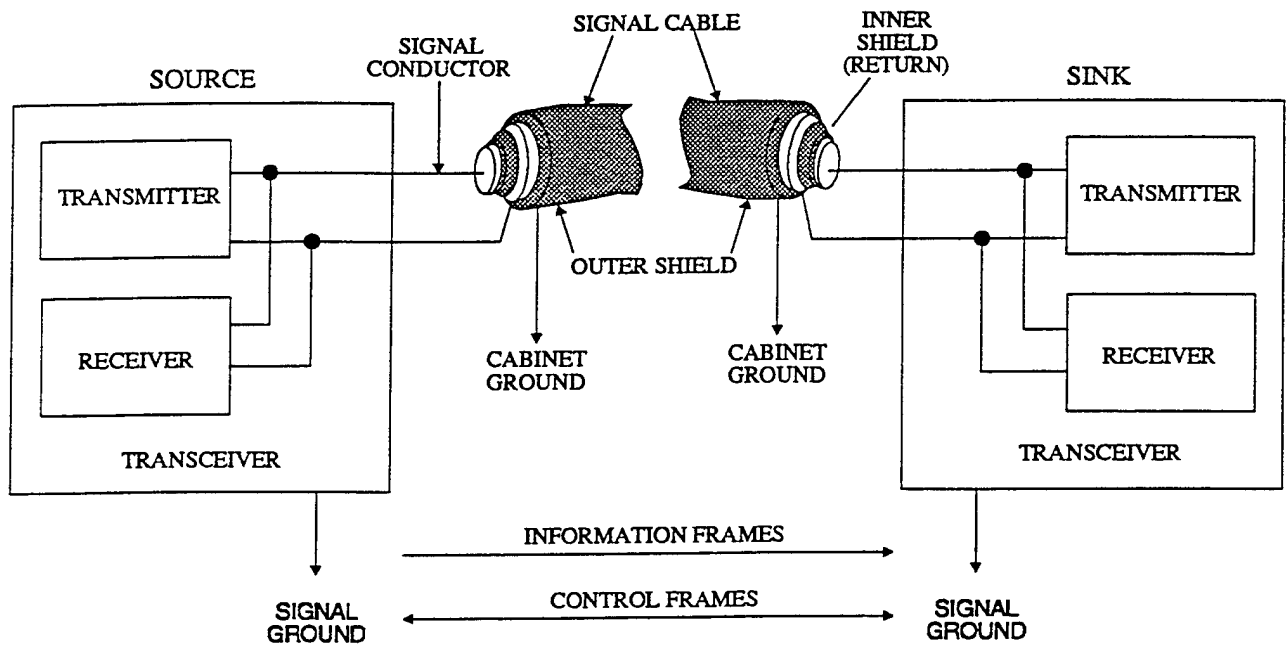

LOW LEVEL SERIAL COMMUNICATION

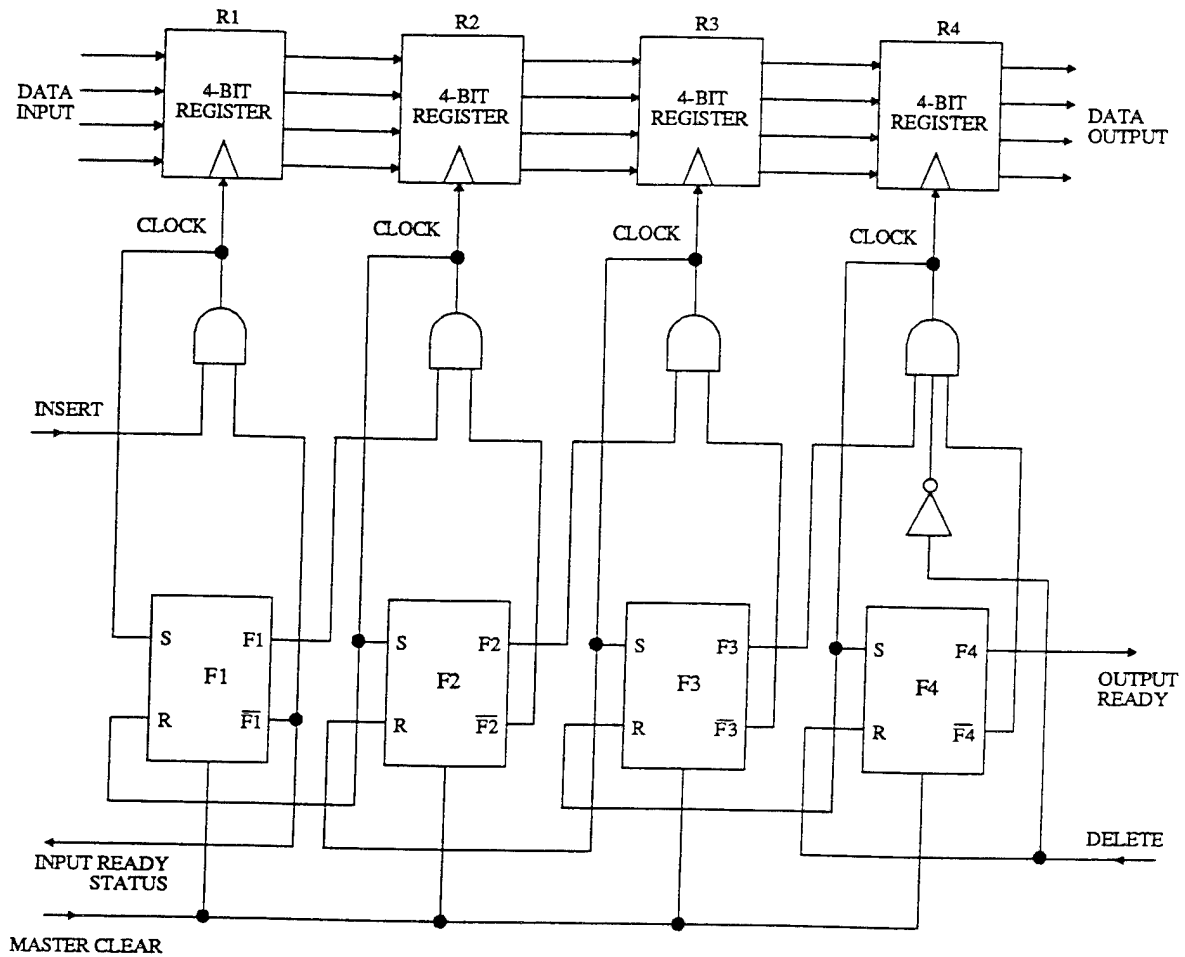

4 BIT BUFFER REGISTER

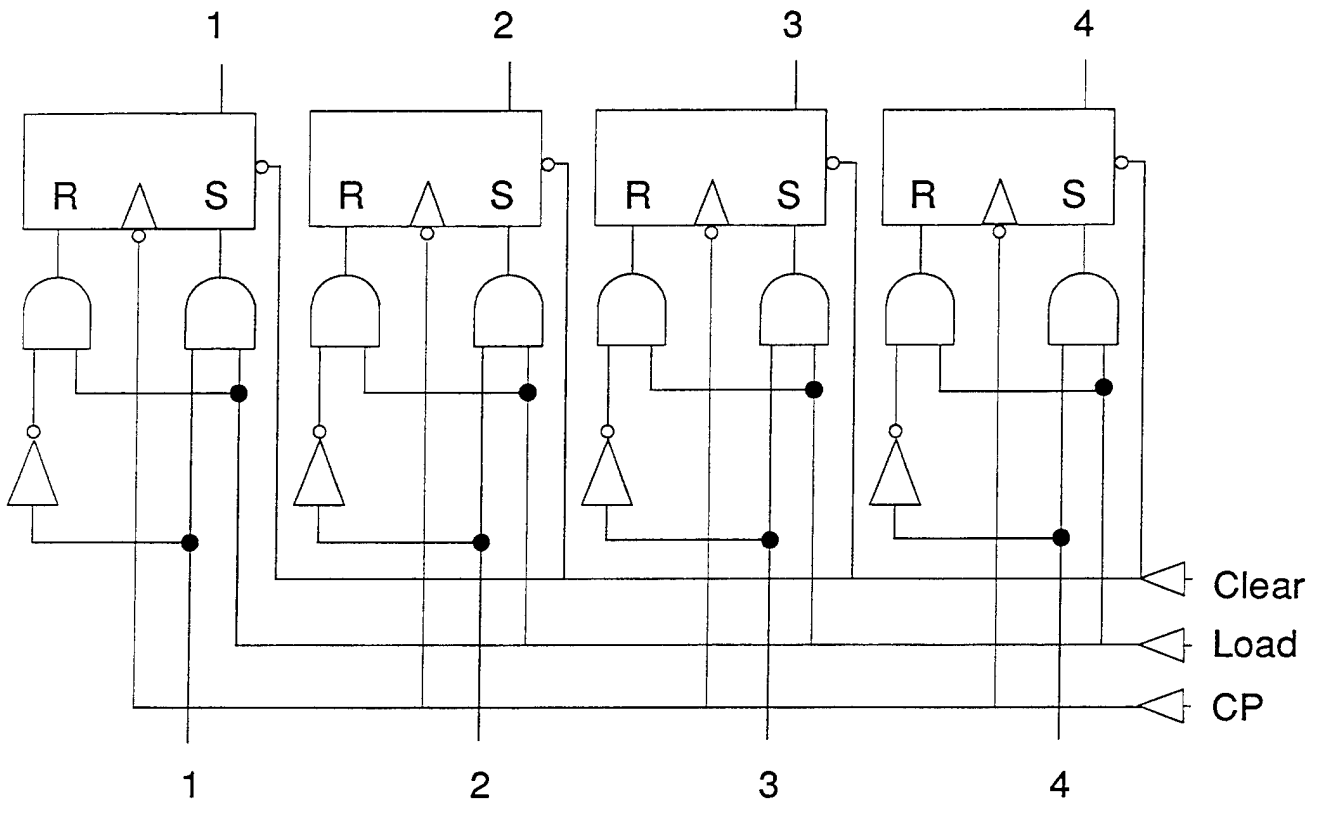

(a) Logic diagram

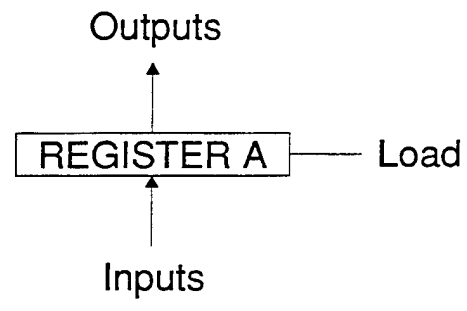

(b) Block diagram

Distribution List

Distribution:

Director, Chief of Naval Research (Code 01)

Director, Personnel/Training and Human Factors Division (Code 461)

Commanding Officer, AEGIS Training Center

Defense Technical Information Center (DTIC) (4)

Copy to:

Technical Director, AEGIS Training Center

Director of Training (N3), AEGIS Training Center

Deputy Director of Training (N3A), AEGIS Training Center

Director, Submarine Manpower and Training Requirements (N879C)

Chief of Naval Education and Training (L01)