



**US Army Corps
of Engineers**
Waterways Experiment
Station

Wetlands Research Program Technical Report WRP-SM-5

Construction and Monitoring of Water and Sediments in Wetlands Created in the Black Butte Reservoir Fluctuation Zone, Orland, California

by Charles W. Downer

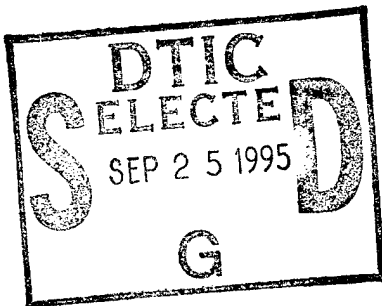

19950919 358



DTIC QUALITY INSPECTED 8



August 1995 – Final Report
Approved For Public Release; Distribution Is Unlimited

The following two letters used as part of the number designating technical reports of research published under the Wetlands Research Program identify the area under which the report was prepared:

	<u>Task</u>		<u>Task</u>
CP	Critical Processes	RE	Restoration & Establishment
DE	Delineation & Evaluation	SM	Stewardship & Management

The contents of this report are not to be used for advertising, publication, or promotional purposes. Citation of trade names does not constitute an official endorsement or approval of the use of such commercial products.



Construction and Monitoring of Water and Sediments in Wetlands Created in the Black Butte Reservoir Fluctuation Zone, Orland, California

by Charles W. Downer

U.S. Army Corps of Engineers
Waterways Experiment Station
3909 Halls Ferry Road
Vicksburg, MS 39180-6199

Accession For	
NTIS	CRA&I <input checked="" type="checkbox"/>
DTIC	TAB <input type="checkbox"/>
Unannounced <input type="checkbox"/>	
Justification	
By	
Distribution /	
Availability Codes	
Dist	Avail and/or Special
A-1	

Final report

Approved for public release; distribution is unlimited



**US Army Corps
of Engineers**
Waterways Experiment
Station

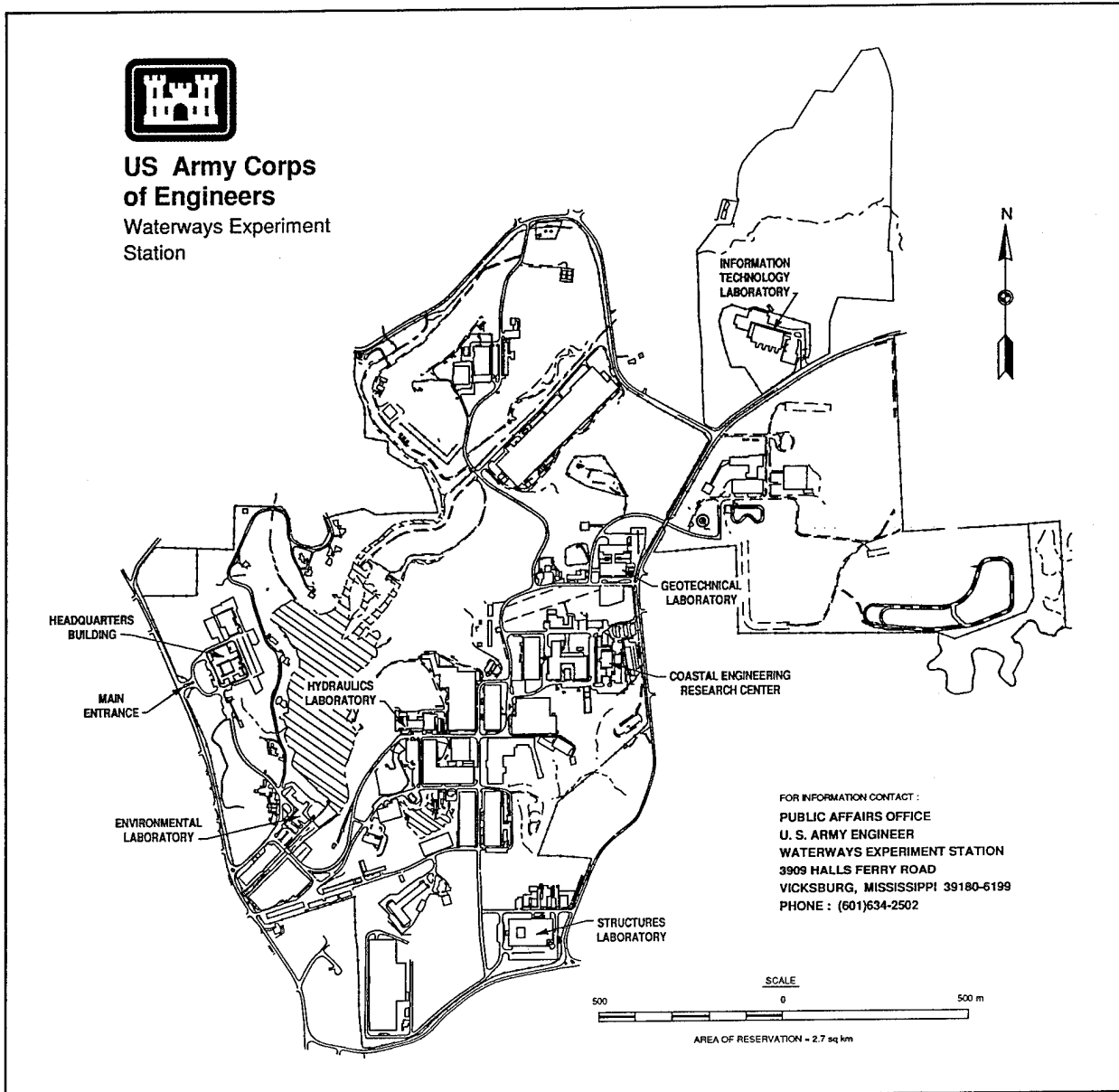

Waterways Experiment Station Cataloging-in-Publication Data

Downer, Charles Wayne.

Construction and monitoring of water and sediments in wetlands created in the Black Butte Reservoir fluctuation zone, Orland, California / by Charles W. Downer ; prepared for U.S. Army Corps of Engineers.

59 p. : ill. ; 28 cm. -- (Technical report ; WRP-SM-5) (Wetlands Research Program technical report ; WRP-SM-5)

Includes bibliographic references.

1. Constructed wetlands -- California. 2. Sedimentation and deposition -- California. 3. Water quality management. 4. Wetlands -- California. I. United States. Army. Corps of Engineers. II. U.S. Army Engineer Waterways Experiment Station. III. Wetlands Research Program (U.S.) IV. Title. V. Series: Wetlands Research Program technical report ; WRP-SM-5. VI. Series: Technical report (U.S. Army Engineer Waterways Experiment Station) ; WRP-SM-5.

TA7 W34 no. WRP-SM-5



Sedimentation in Constructed Wetlands

Construction and Monitoring of Water and Sediments in Wetlands Created in the Black Butte Reservoir Fluctuation Zone, Orland, California (TR WRP-SM-5)

ISSUE:

The U.S. Army Corps of Engineers owns and operates hundreds of reservoirs for flood control and water supply. Operation of the reservoirs for flood control and water supply typically calls for a fairly predictable fluctuation of water levels within the reservoir. This operation provides lake managers with an opportunity to construct wetlands in the fluctuation zone of the reservoir, that area of the reservoir between flood and conservation pool. These wetlands potentially provide both habitat and water quality functions.

RESEARCH:

The Sacramento District constructed six wetlands in the Black Butte Reservoir fluctuation zone in December of 1991. The Stewardship and Management Task Area of the Wetlands Research Program provided planning, oversight, monitoring, data analysis, and interpretation for the demonstration project. The wetlands were to demonstrate low-cost wetland construction techniques and the ability of constructed wetlands to capture and retain suspended sediments. The Sacramento District was responsible for construction of the wetlands. Monitoring of water levels, flows, suspended sediment concentrations, and sediment accumulation in the wetlands was conducted from the time of construction until June 1994.

SUMMARY:

Approximately eight acres of wetlands were created in the fluctuation zone of the Black Butte Reservoir at an estimated cost of less than \$20,000. Construction costs were kept to a minimum by carefully selecting appropriate sites. The wetlands proved to be effective sediment traps, retaining high percentages of incoming sediments, and accumulating sediments at a high rate. However, the establishment of wetland vegetation was hampered by sustained flooding of the reservoir and the inability of the wetlands to retain water once the lake receded.

AVAILABILITY OF REPORT:

The report is available on Interlibrary Loan Service from the U.S. Army Engineer Waterways Experiment Station (WES) Library, 3909 Halls Ferry Road, Vicksburg, MS 39180-6199, telephone (601) 634-2355.

To purchase a copy, call the National Technical Information Service (NTIS) at (703) 487-4650. For help in identifying a title for sale, call (703) 487-4780. NTIS report numbers may also be requested from the WES librarians.

About the Author:

Charles W. Downer is a research hydraulic engineer in the U.S. Army Engineer Waterways Experiment Station Hydraulics Laboratory. Point of contact is Mr. Downer at (601) 634-2473.

Contents

Preface	viii
Conversion Factors, Non-SI to SI Units of Measurement	x
1—Introduction	1
Purpose	2
Site Description	2
Reservoir Operation	3
Climate	4
2—Construction Process	6
Setting Objectives and Defining Functions	6
Site Selection	7
Simple, low-cost construction	7
Suspended sediments	7
Water balance	7
Hydraulic design	10
Compatibility with other lake functions	10
Final site selection	10
Construction Techniques	13
Construction Cost	15
3—Sampling Materials and Methods	17
Water	17
Wetland water level measurement	17
Lake water surface elevations	23
Wetland flows	23
Sediments	23
Suspended sediments	23
Sediment accumulation	24
Climate Data	25
Vegetation	25
4—Results and Discussion	26
Water Balance	26
Rainfall and evaporation	26
Reservoir flows, levels, and wetland inundation	26
Reservoir flows	26

Reservoir levels and wetland inundation	26
Wetland water levels and flows	29
Wetland 1	30
Wetland 2	30
Wetlands 3-6	32
Sediments	35
Suspended sediments	35
Sediment accumulation	36
1992 Sampling	36
1993 Sampling	39
Analysis and discussion	40
Differences between measurement techniques	45
Vegetation	46
5—Conclusions	47
References	49
SF 298	

List of Figures

Figure 1. Black Butte Reservoir location map	3
Figure 2. Rule curve for Black Butte Reservoir	4
Figure 3. Maximum monthly water surface elevations at Black Butte Reservoir	4
Figure 4. Exposed mud flats at Black Butte Reservoir	5
Figure 5. Example of possible wetland site	8
Figure 6. Erosion along lake boundary	9
Figure 7. Constructed wetlands locations	11
Figure 8. Construction of wetland dikes	14
Figure 9. Sampling locations	18
Figure 10. Sampling techniques in large wetlands	21
Figure 11. Crest gauge construction	22
Figure 12. Monthly rainfall at Black Butte Reservoir	27
Figure 13. Monthly pan evaporation at Black Butte Reservoir	27
Figure 14. Black Butte Reservoir inflows	28
Figure 15. Black Butte Reservoir outflows	28
Figure 16. Black Butte Reservoir water surface elevations	29
Figure 17. Wetland 1, 1994 water surface elevations	31

Figure 18.	Wetland 2, 1994 water surface elevations	31
Figure 19.	Wetland 3, 1994 water surface elevations	32
Figure 20.	Wetland 4, 1994 water surface elevations	33
Figure 21.	Wetland 5, 1994 water surface elevations	33
Figure 22.	Wetland 6, 1994 water surface elevations	34
Figure 23.	Data and regression from 1992 feldspar pad sampling of Wetlands 1 and 2	43
Figure 24.	All sediment accretion data from Wetlands 1-6, 1992 and 1993	44

List of Tables

Table 1.	Average Monthly Evaporation and Precipitation at Orland, California	5
Table 2.	Estimated Monthly Water Balance for Wetlands 1 and 2	12
Table 3.	Construction Specifications for Wetlands	15
Table 4.	Itemized Construction Costs	16
Table 5.	Inundation of Wetlands	30
Table 6.	Peak Water Surface Elevations and Flows, Wetlands 3-6	34
Table 7.	Suspended Sediment Concentrations from Grab Samples, 1993 and 1994	35
Table 8.	Sediment Accumulation Sampling Summary	36
Table 9.	Sediment Sampling Data	37
Table 10.	Sedimentation Patterns in Black Butte Reservoir	41
Table 11.	Elevation and Accretion/Accumulation Linear Regression Models	42

Preface

The work described in this report was authorized by Headquarters, U.S. Army Corps of Engineers (HQUSACE), as part of the Stewardship and Management Task Area of the Wetlands Research Program (WRP). The work was performed under Work Unit 32766, "Wetland Stewardship and Management Demonstration Areas," for which Mr. Chester O. Martin, U.S. Army Engineer Waterways Experiment Station (WES), was the Technical Manager. Ms. Denise White (CECW-ON) was the WRP Technical Monitor for this work.

Dr. David Mathis (CERD-C) was the WRP Coordinator at the Directorate of Research and Development, HQUSACE; Dr. William L. Klesch (CECW-PO) served as the WRP Technical Monitor's Representative; Dr. Russell F. Theriot, WES, was the Wetlands Program Manager. Mr. Martin was the Task Area Manager.

The work was performed under the direct supervision of Mr. Charles W. Downer, WES Hydraulics Laboratory (HL). The construction and monitoring of the Black Butte Lake wetland project was done in cooperation with the Sacramento District and the Black Butte Lake project staff. Mr. Mike Helm, Chief Operations Section, and Mr. Joe Holmberg, Chief Natural Resources Unit, provided managerial assistance in the construction of the project. Mr. Henry Hornsby, Black Butte Lake Project Manager, Mr. Brad Long, Senior Park Ranger, and Mr. Skip Sivertsen, Park Ranger, arranged for the construction of the project and assisted in the collection of field data. Additional field assistance was provided by Mr. Calvin Buie, HL. Ms. Laurin Yates, HL, assisted in the production of figures for this report. Technical review was provided by Dr. Lisa Roig, HL, and Mr. Tommy E. Myers, EL.

This report was written under the general direction of Mr. Glenn Pickering, Division Chief of the Hydraulic Structures Division and acting Branch Chief of the Reservoir Water Quality Branch, HL, Mr. Richard Sager, Assistant Director of HL, and Mr. Frank Herrmann, Director of HL.

At the time of publication of this report, Director of WES was Dr. Robert W. Whalin. Commander of WES was COL Bruce K. Howard, EN.

This report should be cited as follows:

Downer, C. W. (1995). "Construction and monitoring of water and sediments in wetlands created in the Black Butte Reservoir fluctuation zone, Orland, California," Technical Report WRP-SM-5, U.S. Army Engineer Waterways Experiment Station, Vicksburg, MS.

The contents of this report are not to be used for advertising, publication, or promotional purposes. Citation of trade names does not constitute an official endorsement or approval of the use of such commercial products.

Conversion Factors, Non-SI to SI Units of Measurement

Non-SI units of measurement used in this report can be converted to SI units as follows:

Multiply	By	To Obtain
acres	4,046.873	square meters
acre-feet	1,233.489	cubic meters
cubic feet	0.02831685	cubic meters
feet	0.3048	meters
inches	2.54	centimeters
miles (U.S. statute)	1.609347	kilometers
square miles	2.589998	square kilometers

1 Introduction

Realizing the many important functions that wetlands perform, wetlands are being constructed to perform these functions in the absence of natural wetland areas. One often overlooked opportunity for constructed wetlands is within the fluctuation zone of U.S. Army Corps of Engineers (USACE) reservoirs operated for flood control and water supply. The fluctuation zone of a reservoir is that area in the reservoir between conservation and flood pool elevations. Reservoirs for flood control and water supply are operated according to an operating curve, or rule curve. Large expanses of shallow areas may become exposed during drawdown. These areas, located in the fluctuation zone of the reservoir, are often devoid of vegetation. Because of this operation, an opportunity exists to establish vegetated wetlands upon these normally shallow areas. Though intermittently inundated, the wetlands would be capable of supporting several important wetland functions.

Wetlands located in the fluctuation zone of the reservoir can be used for sediment control and water quality enhancement by locating them to intercept high sediment concentration inflows. Along with sediments, toxic substances, such as pesticides and heavy metals, often associated with fine sediments, could be captured and detained. Establishing vegetated wetlands could help to reduce resuspension upon the shallow flats by providing wind breaks and binding bottom sediments. Halting resuspension increases water clarity and improves water quality. In addition to the water quality functions that the wetlands may perform, constructed wetlands have the potential to provide wildlife and fisheries habitat on an otherwise barren landscape. The wetlands may provide wildlife habitat during low-water periods when the wetlands are exposed. Vegetated wetlands provide a source of food, water, and shelter for visiting wildlife. The vegetation and control structures can provide fisheries habitat when the wetlands are inundated.

Much of once expansive wetlands in the Sacramento valley have been drained and converted to agricultural use, leaving the area lacking in natural wetlands. Because of this, the Sacramento District and Black Butte Lake personnel were very interested in developing a Wetlands Research Program (WRP) wetland demonstration site at Black Butte Reservoir. The WRP was interested in constructing wetlands in the Pacific northwest. Black Butte Reservoir, located in northern California, provided an opportunity to construct wetlands in the reservoir fluctuation zone because the operating curve of the

reservoir subjects the lake to large fluctuations in water-surface elevation. Six wetland areas were constructed in December 1992 in the fluctuation zone of Black Butte Reservoir. Construction was performed by the Sacramento District under the supervision of the WRP. The wetlands were monitored as a demonstration area under the Stewardship and Management Task Area of the WRP.

Purpose

Wetlands were constructed at Black Butte Reservoir to demonstrate several key points about created wetlands. The wetlands were to be constructed in the fluctuation zone of the reservoir. This area of the reservoir has great potential as a site for constructed wetlands. The wetlands were to be constructed using simple, low cost, construction techniques that could be effective in reservoir fluctuation zones. The wetlands were to be monitored to document the sediment-accumulating ability of the wetlands. The potential water quality benefits and the useful life of the wetlands for sediment control and other functions were estimated. Experiences gained from constructing and monitoring the demonstration project provided design information for constructing wetlands for sediment control at other reservoirs. The wetlands also provide wildlife and fisheries habitat at Black Butte Lake.

Site Description

Black Butte Lake is a flood control and water supply reservoir operated by the USACE in Northern California and lies in Glenn and Tehama counties. Figure 1 shows Black Butte Lake and its location. When full, the reservoir contains 144,000 acre-ft¹ of water with a surface area of 4,460 acres (USACE 1987). Drainage area for the lake is 741 square miles, and the average annual runoff is 418,600 acre-ft (USACE 1987).

Black Butte lake is located in the foothills of the Coast Range Mountains. The mountains range from elevation 1,200 to 7,500 ft. The foothills range in elevation from 200 to 2,000 ft. The area is made up of rolling, to steep hills and narrow valleys. Soils in the foothills are formed from hard sedimentary rock and are typically well drained and gravelly or calcareous (Begg 1968). Vegetation in the foothills consists primarily of annual grasses, blue oaks, and shrubs. Land in the area is primarily used for cattle range and timber production.

¹ A table of factors for converting non-SI units of measurement to SI units is presented on page x.

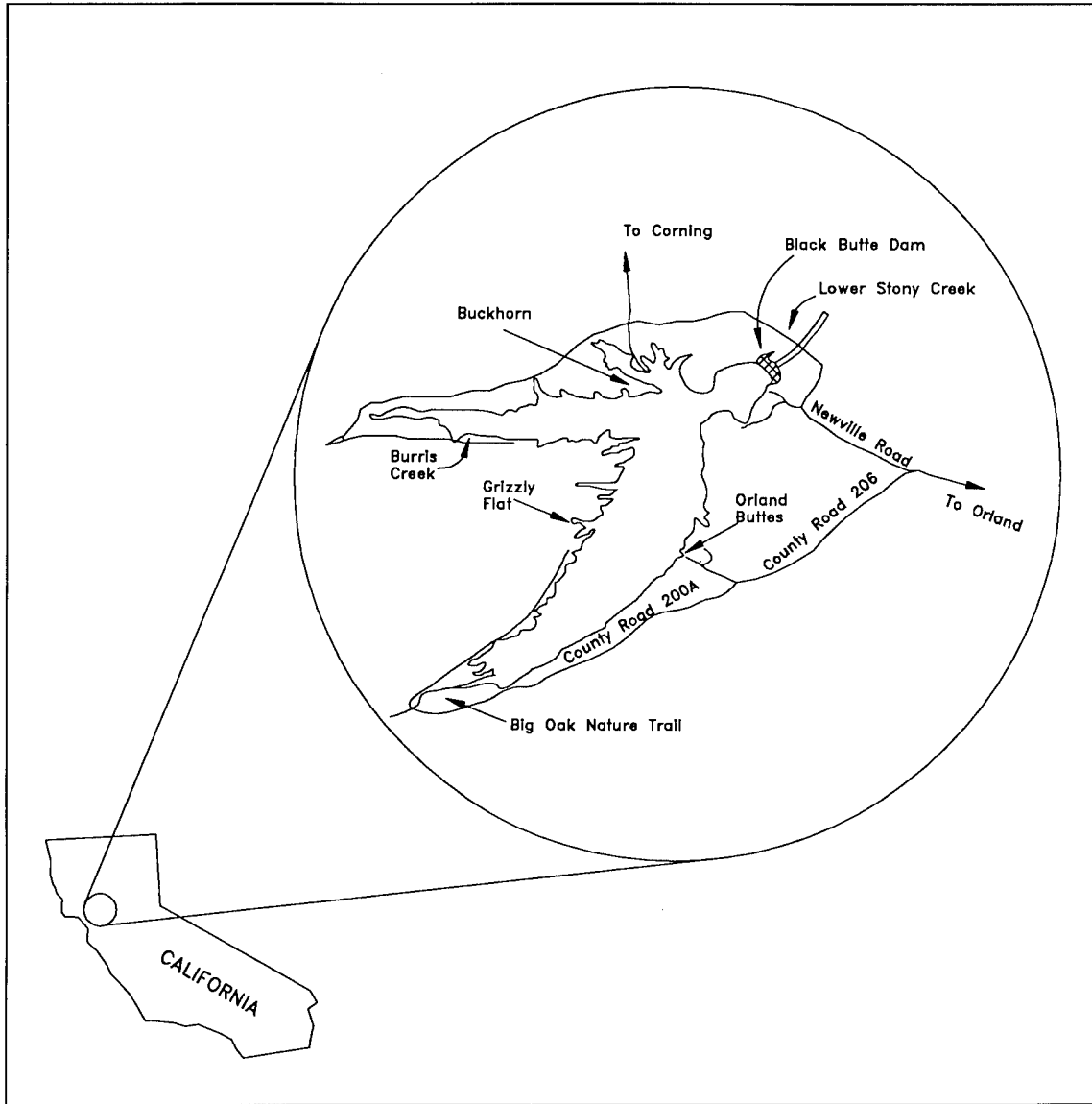

Figure 1. Black Butte Reservoir location map

Reservoir Operation

The lake is operated on the rule curve shown in Figure 2.¹ The actual recorded water levels for the period October 1975 to October 1991 are plotted in Figure 3.¹ The rule curve dictates a water level fluctuation of 30 ft during the year, but the actual variation during the year can be as much as 70 ft.

¹ Unpublished Data, 1992, U.S. Army Engineer District, Sacramento, Sacramento, CA.

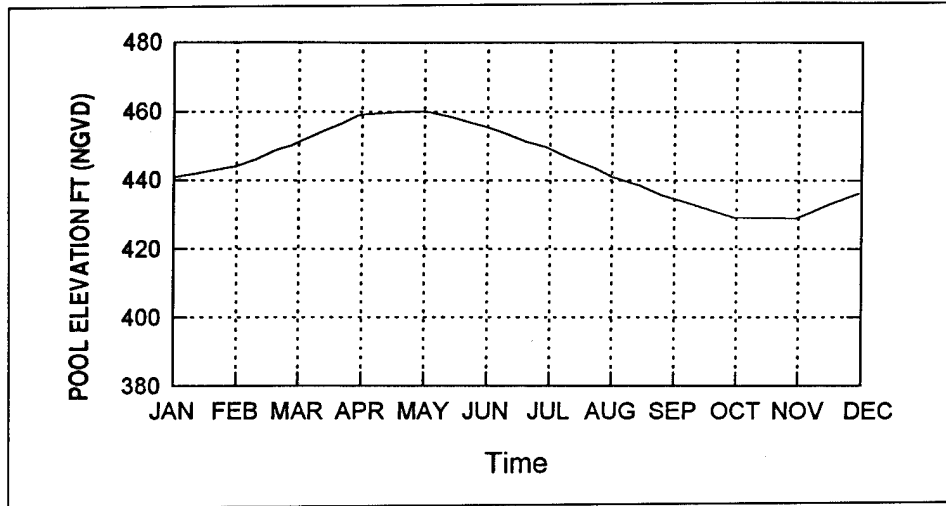

Figure 2. Rule curve for Black Butte Reservoir

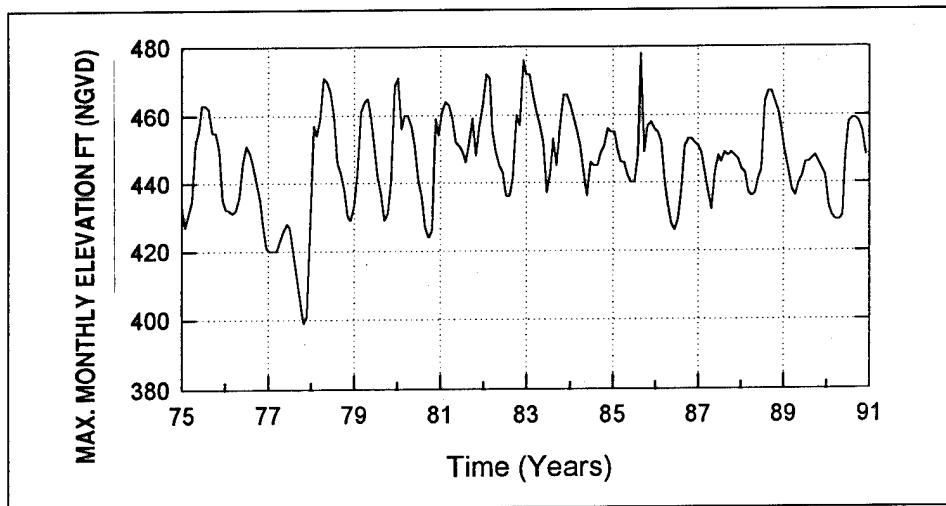

Figure 3. Maximum monthly water surface elevations at Black Butte Reservoir

This type of operation creates large mud flats in the reservoir during the summer and fall months. These mud flats are largely unvegetated or are covered by cockleburrs, with few desirable plants. See Figure 4.

Climate

Average annual rainfall is about 24 in., and average annual evaporation is approximately 74 in. (National Oceanic and Atmospheric Administration (NOAA) 1990). Most of the rainfall occurs in the November to April time frame, comprising approximately 87 percent of the annual precipitation. The



Figure 4. Exposed mud flats at Black Butte Reservoir

average monthly rainfall and evaporation distribution at Orland, CA, are shown in Table 1 (NOAA 1990). Flows into the lake are caused by heavy winter rains. The hydrographs have sharp, high peaks, are usually of short duration, have relatively small volumes, and can occur in rapid succession.

Table 1													
Average Monthly Evaporation and Precipitation at Orland, California													
Month	Jan	Feb	Mar	April	May	June	July	Aug	Sept	Oct	Nov	Dec	Total
Precipitation, in.	4.24	3.20	2.11	1.35	4.81	0.35	0.11	0.25	0.35	1.05	2.85	3.42	24.09
Evaporation, in.	2.10	2.26	4.07	6.85	8.71	10.62	12.14	10.06	7.23	5.31	2.69	2.40	74.44

2 Construction Process

The construction of any wetland project involves several steps, including setting objectives, defining functions, selecting sites, and the actual construction of the wetlands. Each of these steps should be coordinated with the others.

Setting Objectives and Defining Functions

Personnel at the Sacramento District, the Black Butte Lake manager, and the park rangers were primarily interested in wildlife habitat enhancement. They were working on a 5-year resource management plan at the reservoir that incorporates numerous waterfowl, fisheries, and wildlife enhancement features, such as limiting cattle grazing, creating rock jetties and piles, and planting willows. The lake manager did not want the wetlands project to interfere with other aspects of the resource management plan.

The research objectives were described in Chapter 1 and, although not necessarily conflicting, were different from the objectives of the lake management personnel. In addition, both Sacramento District and Black Butte Lake Project personnel did not think that suspended sediments were a real problem at this site.

Demonstration projects in the WRP were constructed and monitored on a cooperative basis between interested Districts and the WRP. At this site, the expense and details of construction were to be handled by the Black Butte Lake Project. The WRP would help select sites, do hydrologic analysis, provide design plans, oversee construction, and develop and implement monitoring plans. Differences in objectives would have to be resolved if the project was to proceed.

It was decided that the separate objectives could be accomplished by the same project if properly sited and designed. The constructed wetlands would then provide the functions of wildlife habitat, fisheries habitat, and water quality enhancement through the capture of suspended sediments and reduced resuspension of sediments.

Site Selection

The constructed wetlands had to perform their intended functions and fit both the research goals of the U.S. Army Engineer Waterways Experiment Station (WES) and the habitat goals of the project. This required careful consideration of possible construction sites. Possible wetland construction sites were judged upon the following criteria.

- a. The site must allow for simple, low-cost construction techniques.
- b. The wetland must be located where it has the opportunity to capture and detain suspended solids in inflows.
- c. The wetland must retain water for part of growing season to provide an opportunity for wetland plant growth and wildlife usage.
- d. The wetland construction must be compatible with existing activities and plans at the lake.

Simple, low-cost construction

The selected site had to allow for simple and low-cost construction to meet the research objectives. In order to do this, sites were selected that could easily be impounded by constructing dikes. This could be accomplished by damming natural drainage areas within the lake bed. Such areas appear as small indentations along the contour lines of topographical maps of the lake and allow for a maximum of wetland surface area to be impounded with minimal construction. An example of such a site is shown in Figure 5.

Suspended sediments

Creating wetlands by constructing dikes across small natural drainage basins assured the objective that an adequate suspended sediment load would be delivered to the wetlands. These small drainages carry concentrated flow from uplands around the lake to the conservation pool of the reservoir. Many of the upland areas in these basins are eroding (Figure 6); and the concentrated flow in these drainages has increased suspended sediment-carrying capacity.

Water balance

In order to determine if the wetland would retain enough water to support wetland vegetation, a water balance was constructed for sites that satisfied the first two criteria. Sources of water were rainfall, runoff, and reservoir flooding. Water sinks are evaporation and overflows. It was realized that seepage from the wetlands could be important; but seepage was not easily quantified.

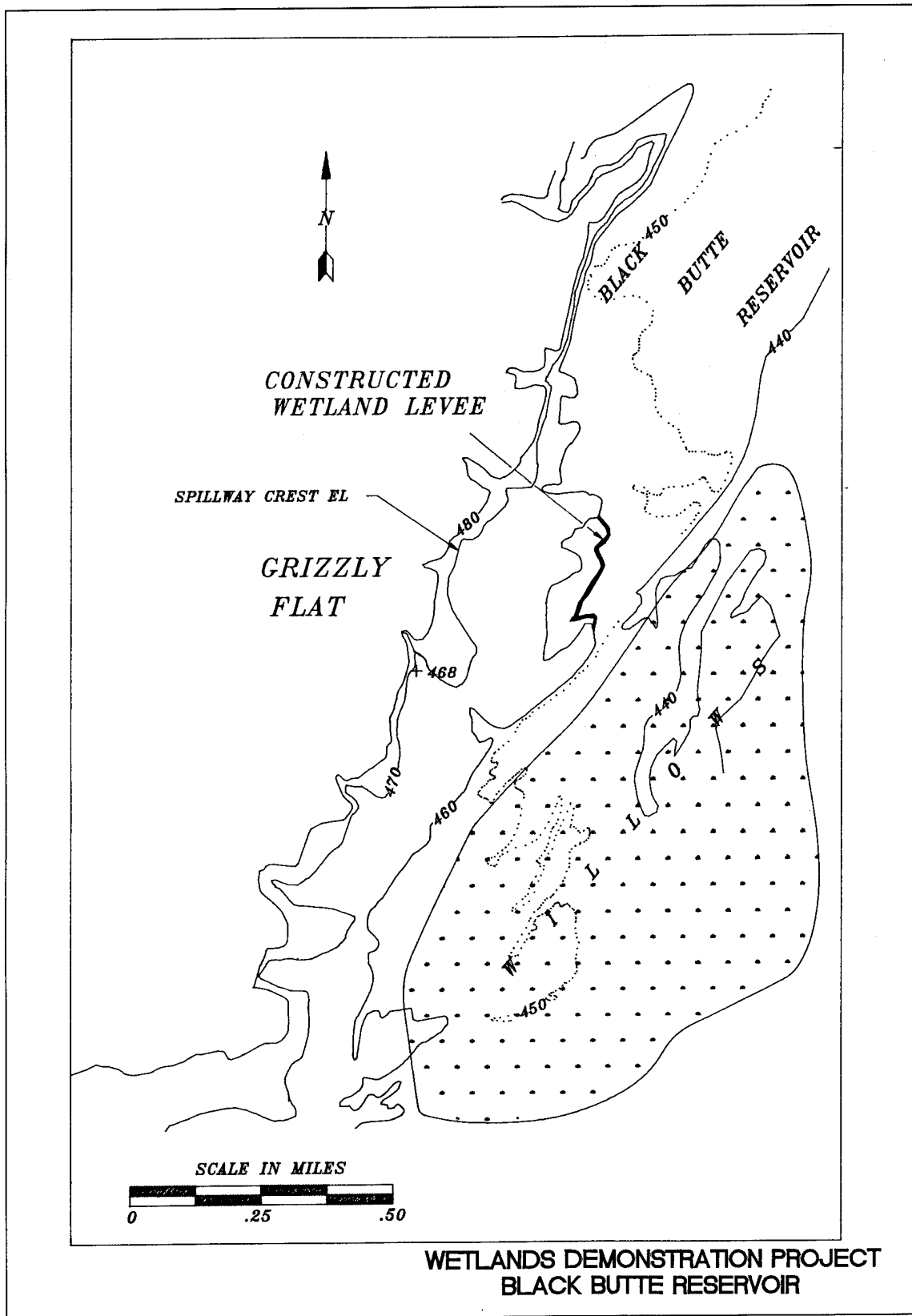

Figure 5. Example of possible wetland site

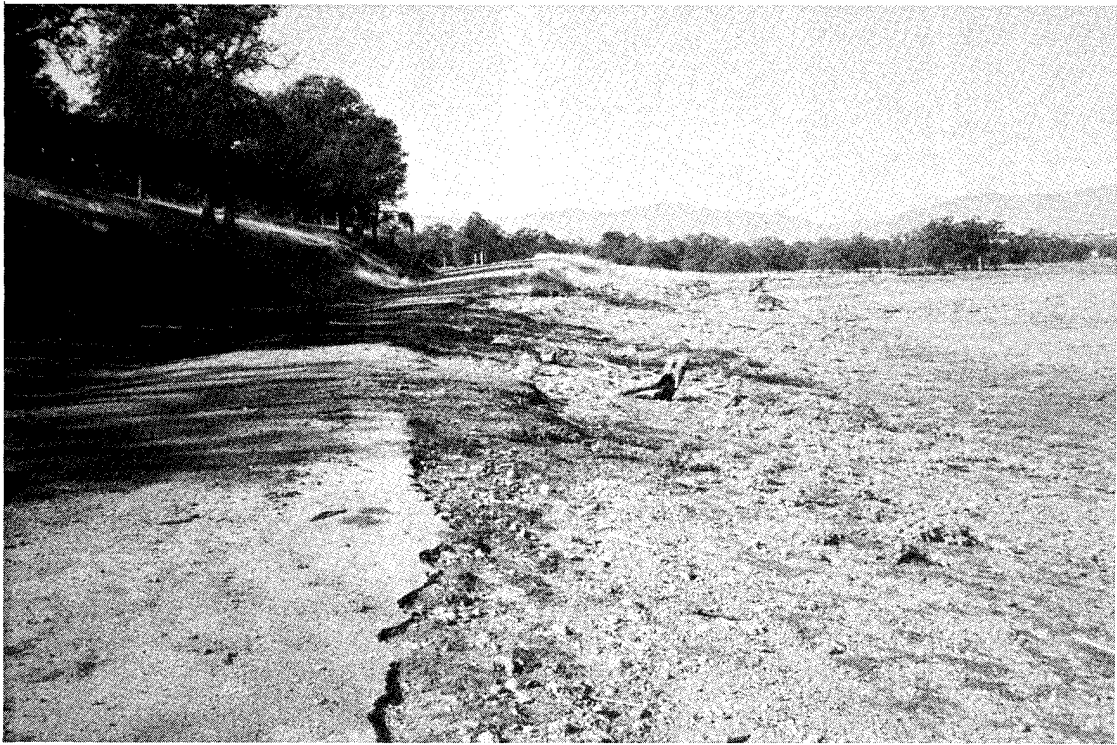

Figure 6. Erosion along lake boundary

Because of the timing and small volume of rainfall, high evaporation rates, and the reservoir operation, it quickly became apparent that to provide water in the wetland during part of the growing season would require that the wetland be inundated by the reservoir each year. Because of the normal operating curve, this would require that the wetlands be located between elevations 430 and 460. Although the reservoir is frequently operated outside the normal operating curve, locating the wetlands within this range provides the greatest inundation opportunity.

Hydraulic design

Along with the water balance, a preliminary hydraulic analysis of required outlet structures was performed. This analysis consisted of determining the drainage basin size of the proposed wetlands and applying a hypothetical rainfall event to the drainage basin to estimate peak flow over the structure. A rainfall intensity of 1 in. per hour was chosen, based on review of storm events in the area. Runoff from the drainage basin was estimated based on drainage basin characteristics and response of unregulated streams in the area. The analysis was intended to determine if a simple earthen structure with a sandbag or similar spillway could accommodate the estimated flow. This analysis was adequate for judging the feasibility of sites. Several potential sites were eliminated because the estimated flow would require more expensive control structures.

Compatibility with other lake functions

In addition to meeting the objectives and providing an opportunity for a simple, yet sound, design, the wetland location must not interfere with other lake uses or concerns. It was important that the wetlands not compete with reservoir water users. In order to simplify the Section 404 permitting process, earthwork was minimized. For these reasons, dike heights were kept 1 m or less. The wetlands could not be located in areas that were known, or thought, to have archeological significance. Finally, wetlands were located to provide maximum wildlife and/or fisheries habitat. Wetlands would be located where either such habitat was largely lacking or where the wetlands could be used as a bridge between two or more types of existing habitat, such as lake and upland.

Final site selection

Working within the framework described above, five wetland sites were selected in the Burris Creek area of the reservoir. The locations of the wetlands are shown in Figure 7. All of the wetlands could be constructed by building low dikes across natural drainage ways. All were located between elevations 430 and 460 ft (National Geodetic Vertical Datum (NGVD)). Sediment loads were anticipated to be high because of apparent erosion in the

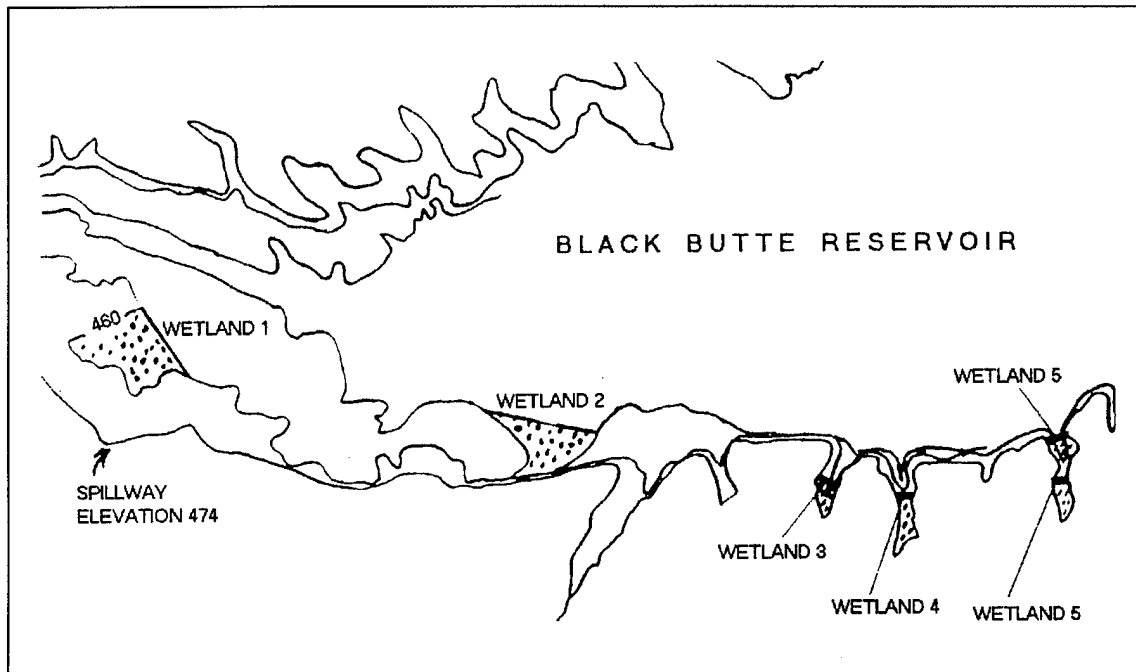

Figure 7. Constructed wetlands locations

surrounding uplands. Burris Creek has little wetland area and is generally lacking in adequate fish structure. Two large wetlands, designated as Wetlands 1 and 2 in Figure 5, were created along elevation lines 460 NGVD and 450 NGVD, respectively, and are located within the Burris Creek floodplain. These larger wetlands encompass an area of approximately 1.5 ha (4 acres) each. Wetlands 1 and 2 provide large areas of wetlands capable of capturing sediments and providing for both fish and wildlife habitat. The soil survey (Gowans 1967) indicated that soils under Wetland 1 would be from the Arbuckle series, are gravelly, and have moderate to moderately rapid permeability. Wetland 2 is located on Wyo series soils (Gowans 1967), which are more clayey and have lower permeability.

A simple hydrologic analysis of Wetland 1 indicated that the wetland had good potential to fulfill its intended functions. According to historic lake operation, the wetland would be inundated for a period of about 2 months per year. It was anticipated that once full, rainfall and runoff would keep the soils saturated for most of the year. A similar analysis of Wetland 2 indicated that the wetland would be completely inundated by the lake for a period of 4 months each year and that this wetland should hold moisture year round. These analyses included rainfall, runoff, evaporation, overflows from the wetland to the lake, overflows from the lake to the wetland, and inundation by the reservoir. Runoff was estimated from monthly rainfall values, estimated wetland drainage areas, and estimated infiltration. Wetlands 1 and 2 had estimated drainage areas of 13 and 9 ha (32 and 22 acres), respectively. These estimated water balances did not include seepage, which was potentially

high, especially in Wetland 1. These screening level analyses assumed normal lake operation and ignored seepage losses.

The water balances of Wetlands 1 and 2 are shown in Table 2. In the table, runoff (Run) and the summation of inputs and outputs (Sum) are depth of water (in inches). Sum is equal to the precipitation plus the runoff minus the evaporation. Negative values indicate a drop in the water level in the wetland. "Over" indicates that overflow from the wetland outlet will occur. "Filled" indicates that the wetland is inundated by the reservoir. "Dry" indicates that the wetland is completely dry.

	Jan	Feb	Mar	April	May	June	July	Aug	Sept	Oct	Nov	Dec
Pre in.	4.21	3.20	2.11	1.35	4.81	0.35	0.11	0.25	0.35	1.05	2.85	3.42
Evap in.	2.10	2.26	4.07	6.85	8.71	10.62	12.14	10.06	7.23	5.31	2.69	2.40
Run 1 in.	10.30	6.00	2.30	0.60	12.90	0.20	0.70	0.40	0.20	0.20	4.70	6.90
Sum 1 in.	12.50	7.00	0.40	-4.90	8.90	-10.00	-11.30	-9.40	-6.70	-4.00	-4.90	7.90
Elev 1	457.90	458.30	458.20	460.00	460.00	459.10	458.20	457.40	456.80	456.50	456.70	457.20
				filled	filled					dry		
Run 2 in.	6.30	3.60	1.40	0.30	7.90	0.10	0.40	0.20	0.10	0.10	2.90	4.20
Sum 2 in.	8.40	4.60	-0.53	-5.10	3.90	-10.10	-11.60	-9.60	-6.70	-4.10	3.00	5.20
Elev 2	449.70	450.10	455.00	460.00	455.00	450.00	450.00	449.20	448.60	448.30	448.60	449.00
		over	filled	filled	filled	filled						

Note: Pre - precipitation, inches; Evap - evaporation, inches; Run - runoff, inches; Sum - Pre + Run - Evap, inches; Elev - Elevation (NGVD) of wetland water surface.

In addition to Wetlands 1 and 2, four smaller wetland areas were created by constructing dikes 2 to 3 ft high across the mouths of three small embayments (Wetlands 3, 4, 5, and 6 in Figure 7). Two of the small wetland areas were created in series in one on the small embayments (Wetlands 5 and 6 in Figure 7). These small wetlands will function as sediment traps to improve reservoir water quality. In addition, once vegetated, these small wetlands will serve as corridors for animals moving between the upland areas and the reservoir. Such habitat is lacking at the project. These wetlands are located on Newvelle soils (Begg 1968), which are gravelly and silty loams. Slopes in these small wetlands are much steeper than in the larger wetlands. No

hydrologic analysis of these wetlands was performed. Because of their relatively low elevation, Wetlands 5 and 6 were predicted to be inundated longer than the other wetlands. All six of these wetlands would be exposed to high runoff as a result of storm events. Because the wetlands were known to be constructed on porous soils, they would only hold water for a short period of time after a rainfall event. It is hoped that these wetlands may develop a less permeable soil as they accumulate fine sediments.

Construction Techniques

The two large wetlands were constructed by building earthen dikes with a small bulldozer. The dams for both wetland areas were created to impound about 1 m of water at the deepest regions in the wetlands, excluding cut material. It was desirable to leave the natural sediments undisturbed in the bottom of the wetlands to reduce seepage and increase the time that the areas could hold moisture. Therefore, in Wetland 1, cut material for the dike was taken from the downstream side of the dike. However, Wetland 2 was much shallower and cut material was taken from both sides of the dike to increase the depth of this wetland.

The dike on Wetland 1 is approximately 157 m (514 ft) long, and the Wetland 2 dike is approximately 189 m (620 ft) feet long. A 15-m (50-ft) spillway, constructed of sandbags, was built into each dike. The spillways are approximately 0.15 m (0.5 ft) below the top of the wetland dikes. Dikes were covered with an erosion protection system consisting of netting and plantings of a mix of grasses. This work was completed in February 1992. Dike and spillway construction guidelines are shown in Figure 8. Dikes were surveyed during construction to ensure the proper height. Because of wave erosion, the sandbag dikes were later covered in shot-crete in November of 1993.

The original dikes on the four smaller wetlands were constructed from sandbags mixed with concrete. Because of wind and wave erosion, the dikes were later covered with air blown mortar. A subsurface pond liner was installed at the base of the dikes to inhibit seepage under the dikes and increase the length of time the small wetlands will hold water/moisture. The subsurface pond liner was buried to a depth of approximately 2 m at each of the three sites. Installation of the subsurface liners was completed during the period 9-13 December. Installation of the sandbag dikes was completed in February 1992. The dikes were covered with air-blown mortar in November 1993. The covered dikes also function as overflow structures. A bathymetric survey of the wetlands was conducted after construction was complete. One-half-foot (0.15-m) contour intervals were determined from the survey.

Construction details for the six wetlands are listed in Table 3. The spillway elevation for Wetlands 3-6 refers to the elevation at the center of the dike. There is no well-defined spillway for these dikes. The dikes are lowest in the middle and highest on the ends. The top of dike refers to the high

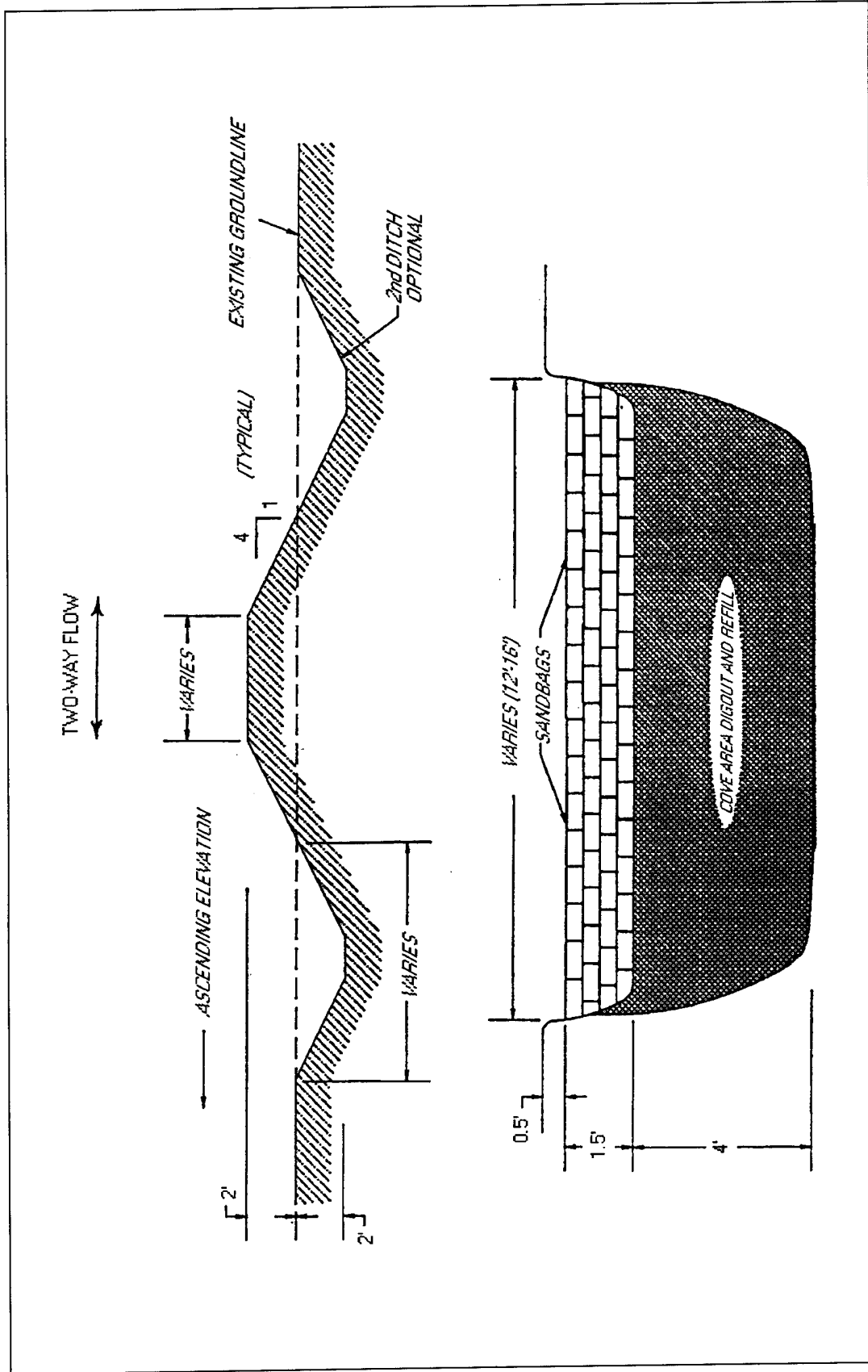

Figure 8. Construction of wetland dikes

Wetland Number	Base Elevation ft NGVD	Spillway Elevation ft NGVD	Top of Dike Elevation ft NGVD	Dike Length m (ft)	Spillway Length m (ft)	Area ha (acres)
1	457.1	458.8	459.8	157 (514)	12.5 (41)	1.42 (3.52)
2	449.5	451.6	451.9	189 (620)	19.8 (65)	1.61 (3.99)
3	458.1	460.8	461.5	11.3		0.041
4	454.6	455.9	459	18.9 (62)		0.054 (0.13)
5	444.6	447.6	451	16.5 (54)		0.047 (0.12)
6	451.0	453.1	454	10.4 (34)		0.013 (0.033)
Totals				403.1 (1,322)		3.19 (7.89)

elevation at the end of the dike. The base of the spillways on Wetlands 3-6 refers to the ground elevation at the time of survey. Significant accumulation of sediments had occurred near the dikes at the time of survey. The original base elevations were on the order of 1 m less than the spillway elevation.

Construction Cost

Because one of the objectives of this project was to demonstrate low-cost construction methods, all material and construction costs were carefully monitored. Total costs for construction of the wetlands was less than \$20,000. Labor costs were minimized by using park rangers and volunteer labor for most of the construction. The labor is valued at \$20,000, for a total wetland cost of \$40,000. This equates to a cost of approximately \$5,000.00 per acre of wetlands. Itemized costs are contained in Table 4 below.

Table 4 Itemized Construction Costs	
Construction Item	Costs
Earthwork - bulldozer backhoe	\$ 1,752.00 432.00
Sandbags	1,400.00
Erosion control material	350.00
Plastic liner	615.00
Air-blown mortar	11,577.00
Installation of monitoring equipment	1,450.00
Grass mix, miscellaneous	1,000.00
Total	\$18,576.00

3 Sampling Materials and Methods

Sediment accretion rates in the constructed wetlands were monitored and related to hydrologic conditions and sediment loads. This information will be used to help make decisions about how to best construct and manage wetlands at USACE projects.

Instrumentation and monitoring were concentrated on the two larger wetlands (Wetlands 1 and 2), which should have a larger impact on the reservoir. Measurements in the larger wetlands were made for water level, inflow, outflow, suspended sediments flux, as well as sediment aggregation. Measurement techniques were designed to minimize instrumentation and take advantage of personnel regularly assigned to monitor the area. Figures 9a-9c show the wetland sampling sites. Figure 9a shows sampling sites at Wetland 1. Figure 9b shows sampling sites at Wetland 2; and Figure 9c shows sampling sites at Wetland 3. Sampling locations in Wetland 3 are representative of sampling locations in each of the small wetlands.

Water

Wetland water level measurement

Figure 10 demonstrates the sampling techniques employed at the larger wetlands. Water depth/level of the wetlands was measured using a staff gauge located at the low point in the wetland. This staff gauge was sufficiently high to measure water depths one-half meter above the crest of the outflow weir. Staff gauges were read several times a week when the wetlands contained water. Steven's water level meters were also installed in the two larger wetlands. The water depth was measured using a Steven's differential pressure transducer and a Steven's data logger. The pressure probe has a range of 3.05 m and is accurate to 1 percent of full range. Water depth was registered every hour on a data card contained in the data logger. Information from the recorder was downloaded to a personal computer for analysis. This system was intended to collect more detailed information than daily observations. The Steven's water level meters had to be removed from the site when

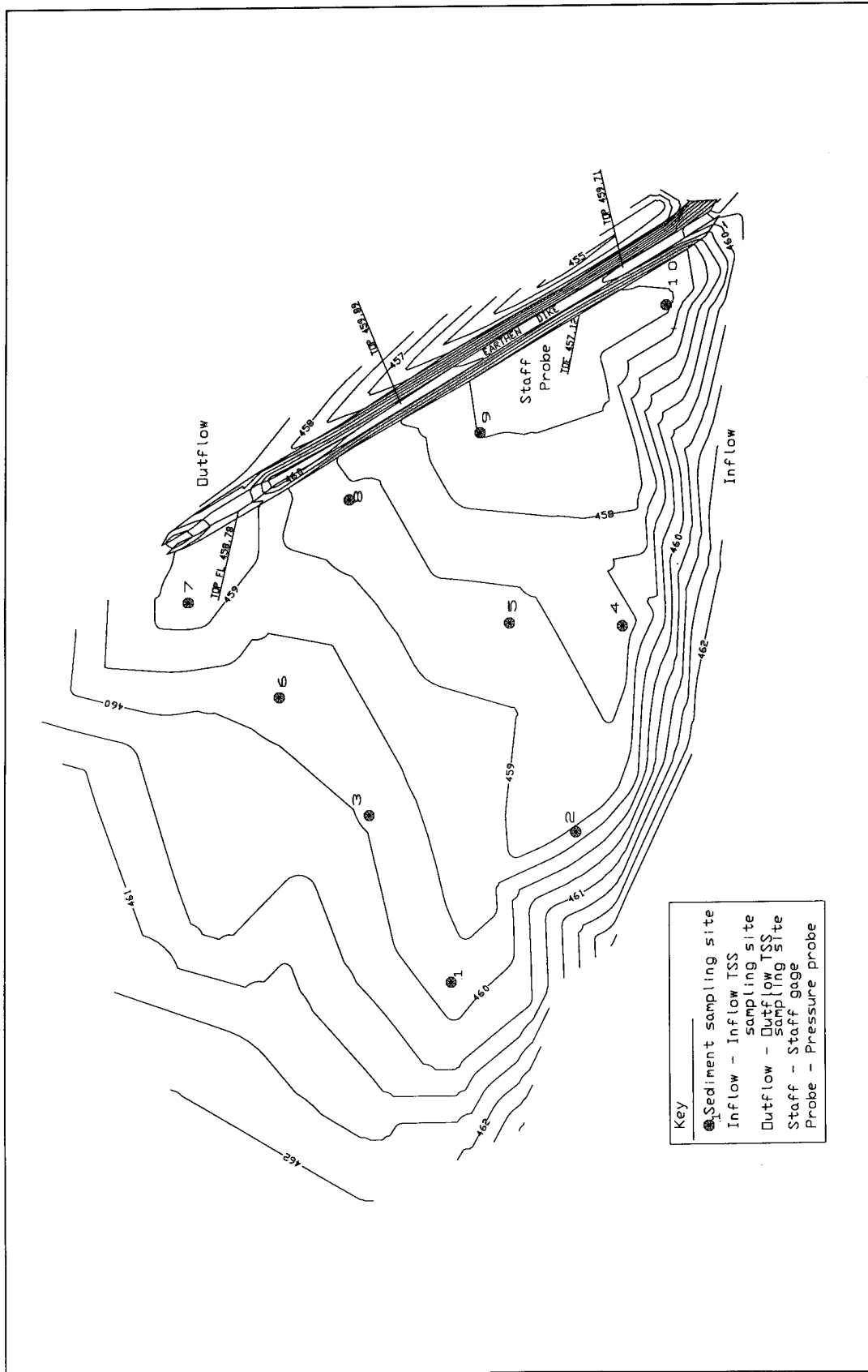

Figure 9. Sampling locations (Sheet 1 of 3)

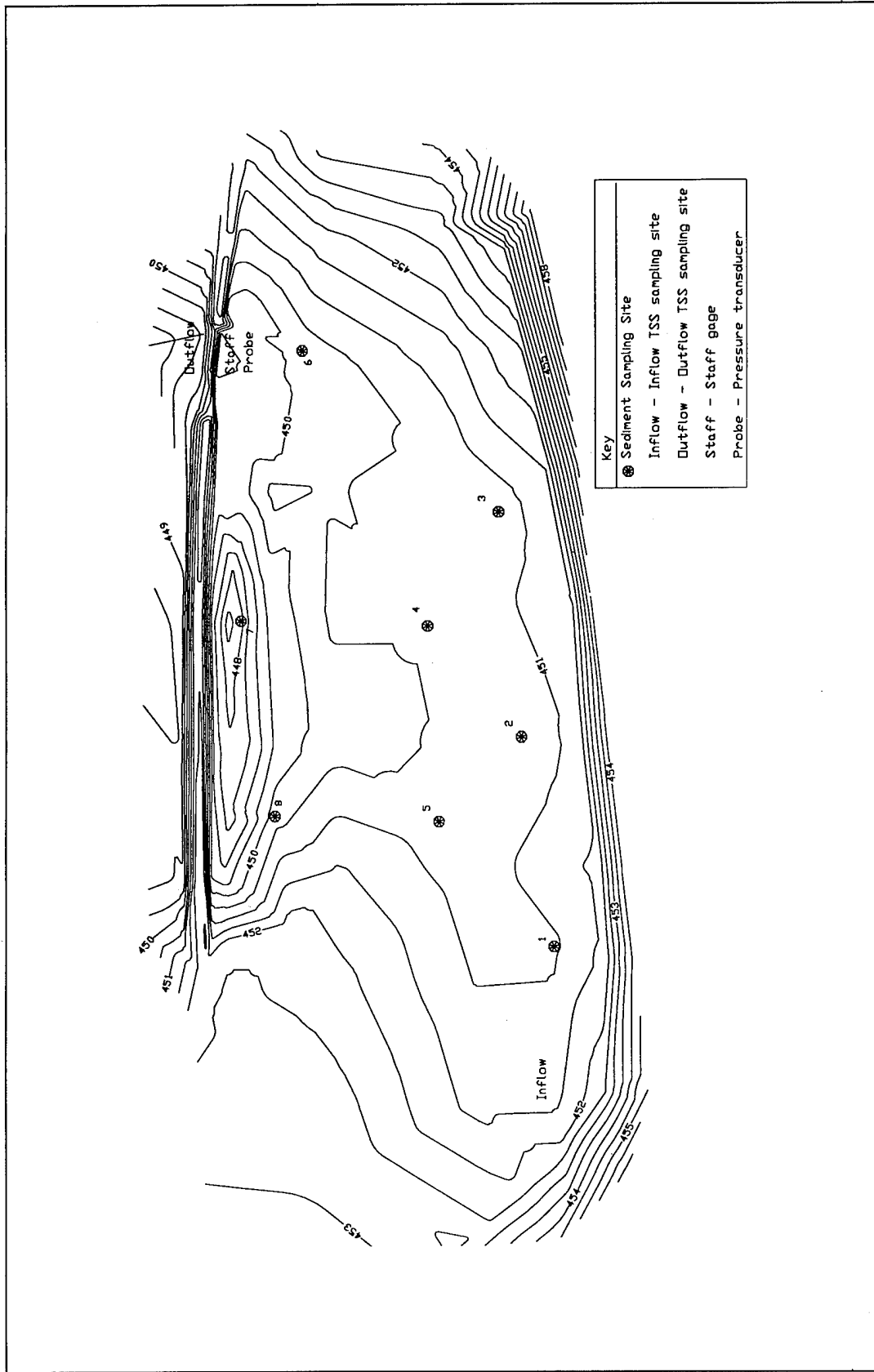

Figure 9. (Sheet 2 of 3)

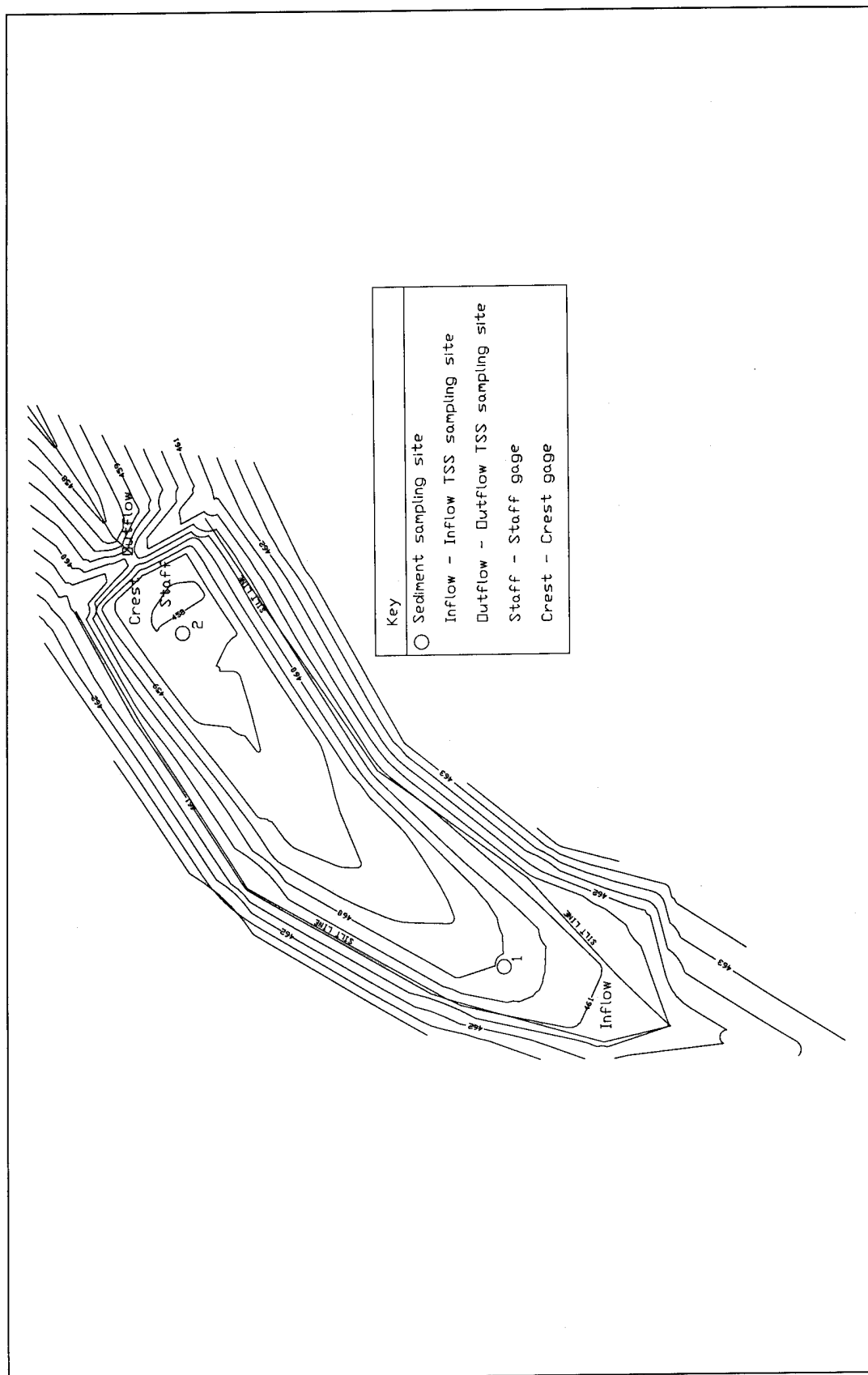

Figure 9. (Sheet 3 of 3)

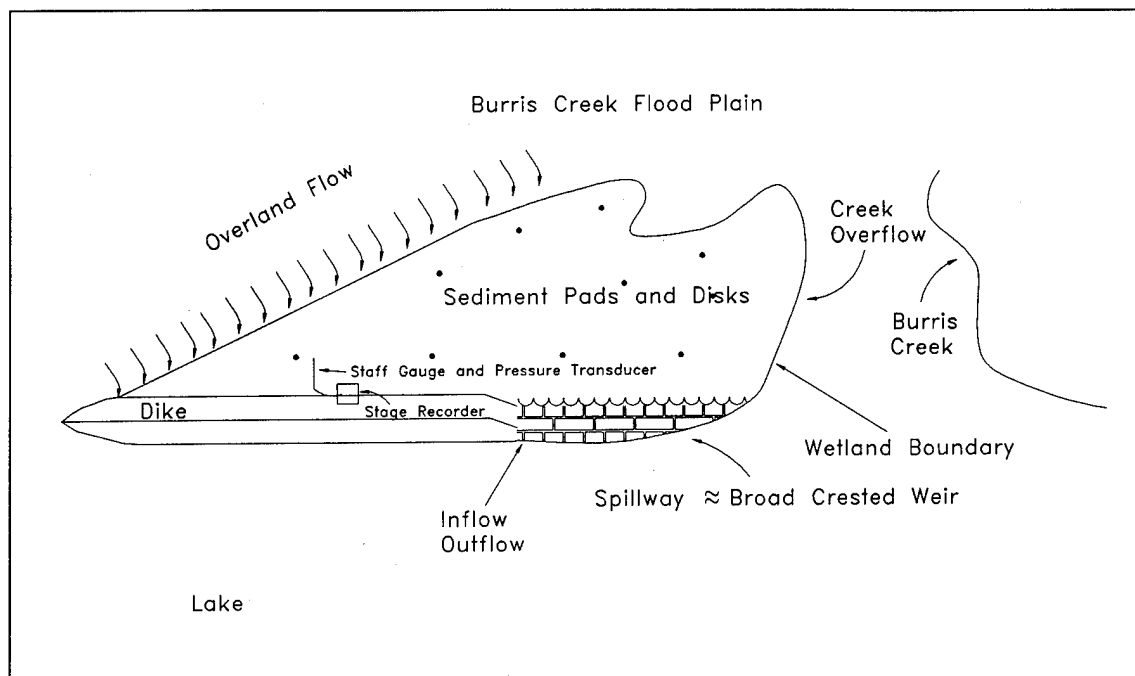

Figure 10. Sampling techniques in large wetlands

inundated by the lake. The location of sampling sites for each wetland area are described in detail in the following paragraphs. See Figure 7 for locations and numbering of wetland sites.

For Wetland 1, the sampling and instrumentation sites are shown in Figure 9a. The location of the pressure transducer (Probe) and staff gauge (Staff) was near the south side of the dike at the deepest area of the wetland (Figure 9a). The data logger was located on the southeast side of the dike.

In Wetland 2, the staff gauge (Staff) and pressure transducer (Probe) were located in front of the outlet weir (Figure 9b). The data logger was located on the northeast corner of the wetland.

Sampling locations in Wetland 3 are shown in Figure 9c. Sampling techniques in the other small wetlands was similar to Wetland 3. Water-level measurements in the smaller wetlands consisted of staff gauges and crest gauges. The staff gauges were identical to the ones installed in the larger wetlands. The staff gauges were set in front of and in the center of the out-flow weirs. Crest gauges were installed to measure peak discharges in the small wetlands after significant rainfall events. Because of the steep slopes in these wetlands, flows were flashy and peak flood heights could not be observed by lake rangers. The crest gauges were constructed of polyvinyl chloride (PVC) pipe, a wooden staff, and a screen wire cup that contained granules of cork. Crest-gauge construction is depicted in Figure 11. During a flow event, the cork would float out of the screen cup and would adhere to

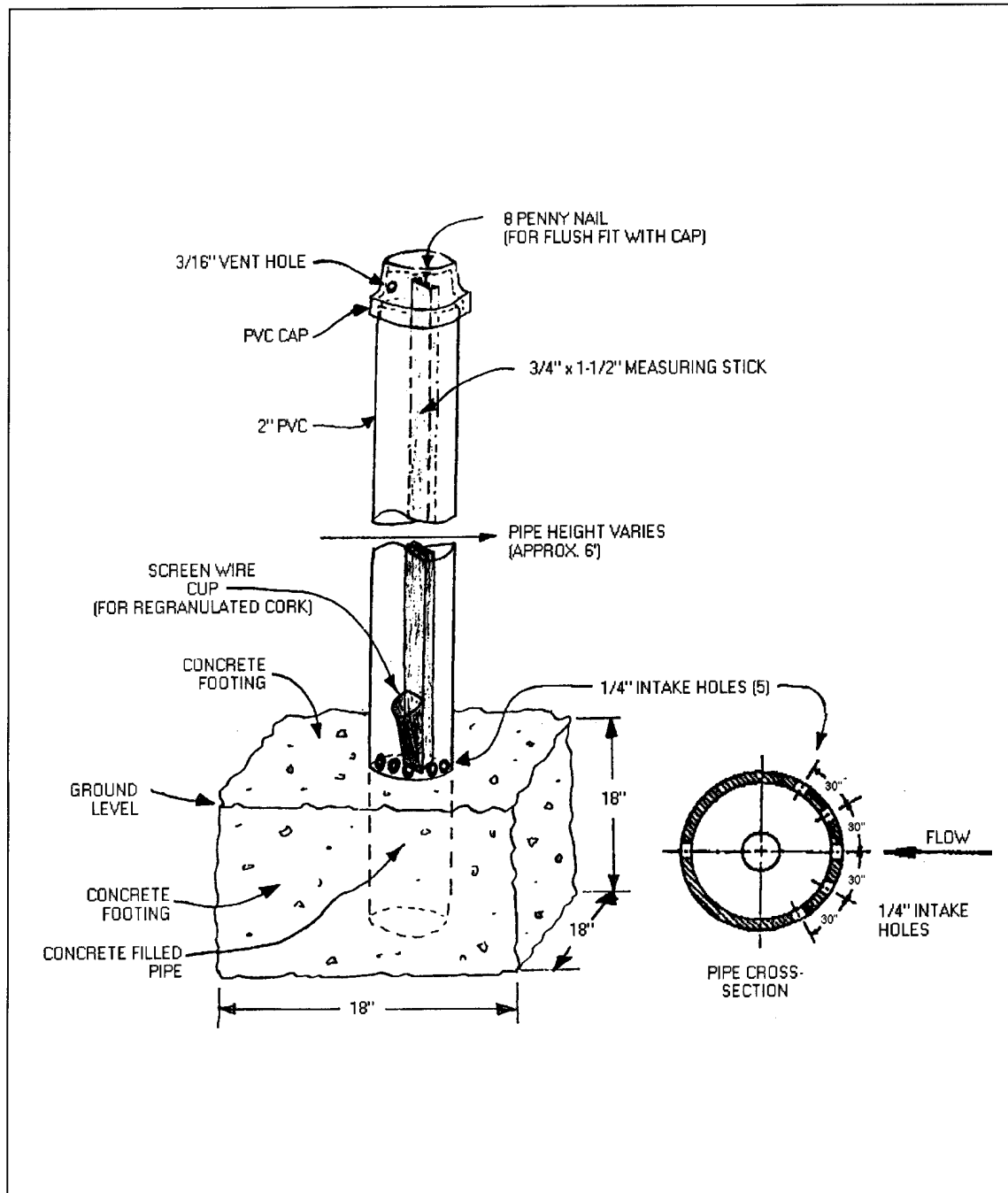

Figure 11. Crest gauge construction

the wooden staff at the peak water level. The crest gauges were set close to the dike and to one side of the dike to facilitate easy access. After a storm event, a ranger could read the peak water level and replace the cork in the screen cup. To deter theft, several holes were drilled in the PVC pipe used for construction of the crest gauges. The bottom of the crest gauges was installed 12 to 18 in. below the ground and cemented in place. The gauges were level and extended approximately 0.5 m above the crest of the dike.

Because of unusually high lake levels, water-level monitoring equipment was not installed until December of 1993, providing data for only the 1994 sampling period.

Lake water surface elevations

Instantaneous measurements of water-surface elevation are recorded every hour at the dam and are available from the Sacramento District.

Wetland flows

Peak flows from the wetlands were computed using the broad-crested weir equation (Chow 1959). Values for head came from the water-level measurements.

Sediments

Suspended sediments

Total suspended sediments (TSS) were monitored to estimate the wetlands' ability to remove suspended sediments from inflows during low-lake level periods. TSS samples were collected from Wetlands 1, 2, and 3. Two types of TSS measurements were made. Weekly samples were taken in the wetlands when water was available. Inflow/outflow events were also sampled when possible. After significant rainfall events, both runoff into the wetlands and weir overflow were sampled. Sampling consisted of grab samples, which are simply single measurements taken at a point in time. All water samples were duplicated. Suspended sediments were determined by Standard Methods Test 208 D. - Total Nonfilterable Residue Dried at 103 to 105 °C (Total Suspended Matter) (American Public Health Association (APHA 1975)). Suspended-sediment samples were collected in 1993 and 1994.

In Wetland 1, scheduled sampling took place at the overflow weir if water was present. As the water receded, samples were collected nearer the south side of the dike, which is deeper. Sampling locations are shown in Figure 9a. Outflow samples (Outflow), during overflow events, were also collected on the outflow weir. Samples were collected as near the center of the weir as safe and practical. Inflow samples (Inflow) were collected in a small drainage area that entered Wetland 1 near the south side of the dike (Figure 9a).

In Wetland 2, scheduled sampling took place from the overflow weir when water was present. As the water receded, samples were collected at a more westwardly location along the dike, which is deeper. Sampling locations are shown in Figure 9b. During overflow events, outflow samples were taken from the overflow weir as near the center of the weir as possible. Inflow samples were collected from the southwest corner of the wetland. Samples

were collected on the south side of the road, in the gully, or preferably on the north side of the road if channelized flow was present.

For Wetland 3, scheduled samples were taken from the center of the outflow weir. Sampling locations are shown in Figure 9c. Inflow samples were taken in the gully upstream of the wetland, and outflow samples were taken from the center of the outflow weir.

Sediment accumulation

Sediment accumulation in the wetlands was measured using two methods. Feldspar clay sediment pads were installed in each of the six wetland areas in December of 1992. Feldspar is a commercially available clay used in pottery. Pads were created by clearing an approximate 1-m square of vegetation and applying the clay powder to the area, approximately 1 to 2 cm thick. Once the feldspar is wet, it becomes cohesive and forms a solid white layer in the soil profile. This white layer is easily identifiable in cores taken from pads after they are covered in sediments. The pads were marked by carsonite markers located near the pads.

During the 1993 low-water period, plexiglass disks, 11 cm in diameter, were also placed in each of the wetlands. These disks were approximately 0.6 cm thick, with the surface roughened with sandpaper to mimic natural terrain (Kleiss 1993). The disks provided an alternative measurement to the feldspar pads. They also may be used in areas with potentially high velocities, such as the smaller wetlands, where the clay may be washed away before having a chance to solidify. It is also easier to estimate the mass accumulation of sediments with the disks. Where possible, the sediment disks were placed in the center of the feldspar pads in order to provide a comparison between the two measuring techniques. These disks were held in place and marked by driving a metal stake through a small hole, 1 cm in diameter, in the center of the disks. In total, 30 disks and 30 feldspar pads were placed.

Locations of the sediment accretion sampling sites are shown in Figure 9. There were 10 sampling sites in Wetland 1 (Figure 9a) and 2 control sampling sites located outside the wetland dike. These control sites were used to compare sediment accretion in the wetland with that in the lake bed outside the wetland. One of the control sites, Site 11, was located about 30 m to the east of the dike; the other site, Site 12, was located approximately halfway between the wetland and the Burris Creek channel. There were 10 sediment sampling sites at Wetland 2, 8 in the wetland (Figure 9b) and 2 control sites. Control site 9 was located approximately 40 m to the north of the dike, and control site 10 was located approximately 40 m to the east of the wetland. Sampling in Wetlands 3-6 consisted of placing an upstream sampling site at approximately the same elevation as the top of the dike and another in the low point of the wetland near the dike (Figure 9c). Wetland 4 had two sampling sites near the dike.

Pads and disks were sampled yearly during low-water periods, late fall when the wetlands were dry. The feldspar pads were sampled in October 1992 and November 1993. The feldspar pads were sampled by either collecting cores from the wetlands using a tin can corer or by removing a piece of the pad using a sharp knife. Depth above the pad was measured to the nearest 0.1 mm using a dial caliper. Three or more samples were taken from each pad, measured, and then averaged to determine the sediment accretion on the pad. Selected cores were collected in sample bags and later analyzed to determine mass accumulation and volatile (organic) content. After coring into the pad through the feldspar horizon, the portion of sediments above the feldspar was removed for this analysis. The soils naturally separated at the feldspar boundary, so that removing the accreted sediments was easily accomplished.

Typically, the pads were cracked because of drying; cocklebur and other vegetation were growing in the pad. Sampling generally was conducted by working around the vegetation. When necessary, the vegetation was carefully pulled by hand to avoid disturbing the pad. In many of the pads, the cracked soil parted at the feldspar horizon. Such pads could be sampled by gently prying a cracked piece of the pad loose and measuring the sediment depth. All pads were replenished after sampling.

Sediment disks were sampled in November 1993. The sediment accretion on each disk was measured in the field with a dial caliper to the nearest 0.1 mm. Several measurements were taken and averaged to estimate the accretion above the disks. Disks were then collected in sample bags and analyzed for dry weight and organic content at WES.

Selected samples were analyzed for Total Solids (TS), used to determine mass accumulation, and determined by oven-drying the samples at 105 °C; organic content, or Volatile Solids (VS), were determined by burning the samples in an oven at 550 °C.

Climate Data

A complete weather station was available at the Black Butte Reservoir field office, located approximately 2 miles from the wetland sites. Precipitation and pan evaporation data were collected every 15 min at this site.

Vegetation

Vegetation was not closely monitored, but the general vegetation composition in the wetland was observed and documented by taking pictures of the wetlands and of the vegetation at each of the sampling sites. This information was used to track vegetation in the wetlands.

4 Results and Discussion

Water Balance

The projected water balances for Wetlands 1 and 2, discussed in Chapter 2, proved to be inaccurate for two reasons. First, the lake inundated the wetlands for a much longer period than the normal period. Secondly, seepage from the wetlands was very high. The substrates for Wetlands 1 and 2 had a very high permeability. Once the lake water receded, the wetlands held water only several days. Runoff from storm events quickly seeped into the ground. Seepage losses accounted for this rapid loss of water. Losses because of evaporation (which was a major part of the preliminary water budget) proved to be minor.

Rainfall and evaporation

Monthly rainfall and evaporation levels are shown in Figures 12 and 13. Rainfall during the spring of 1992 and 1993 was well above normal. This produced a very large volume of runoff, which caused the reservoir to remain unusually high in these years. Although spring rainfall was very heavy, summer rainfall was actually below normal; there was no rainfall during the months of July, August, and September during either year. Rainfall patterns during 1994 were more near the normal levels. Pan evaporation measured at the site did not vary significantly from long-term levels. Pan evaporation rates were high, 20 to 33 cm per month, during late spring and summer when the wetlands contained water but were not inundated by the reservoir.

Reservoir flows, levels, and wetland inundation

Reservoir flows. Reservoir inflows and outflows are shown in Figures 14 and 15. Flows are in cubic meters/day. Heavy spring rains in 1992 caused significant inflows but little outflow (Figure 14). The heavy spring rains of 1993 produced very large inflows and considerable outflow (Figure 15).

Reservoir levels and wetland inundation. Water levels in Black Butte Lake from October 1991 through July 1994 are shown in Figure 16. The

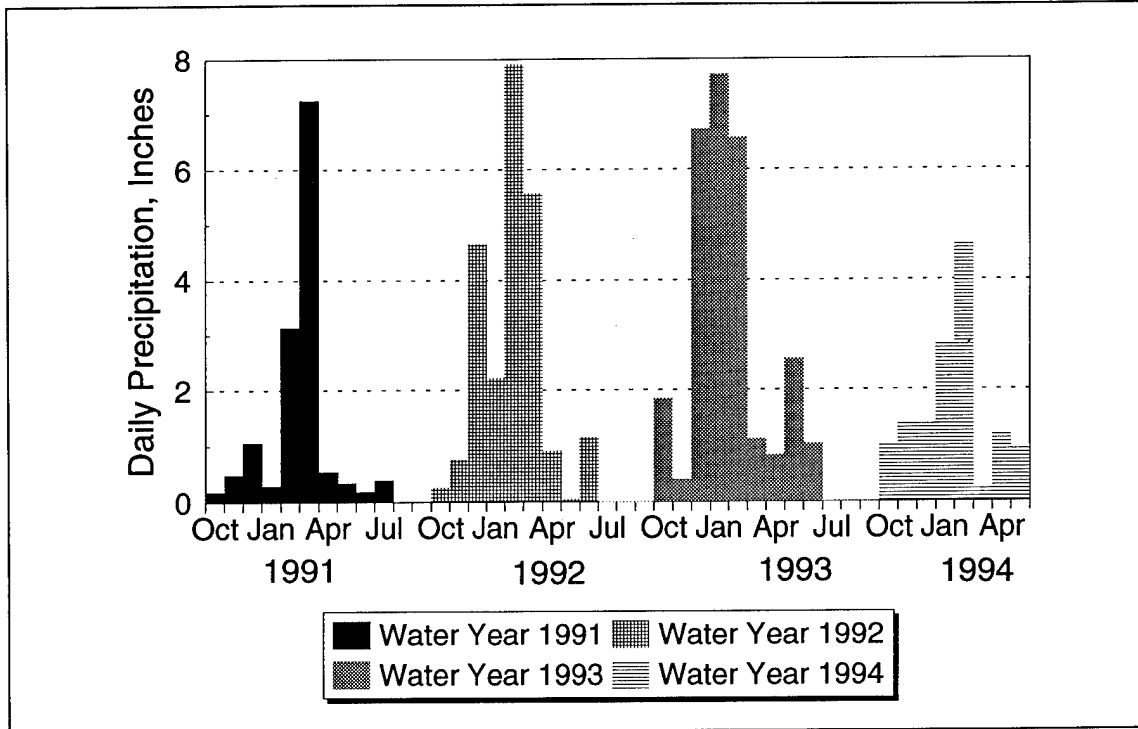

Figure 12. Monthly rainfall at Black Butte Reservoir

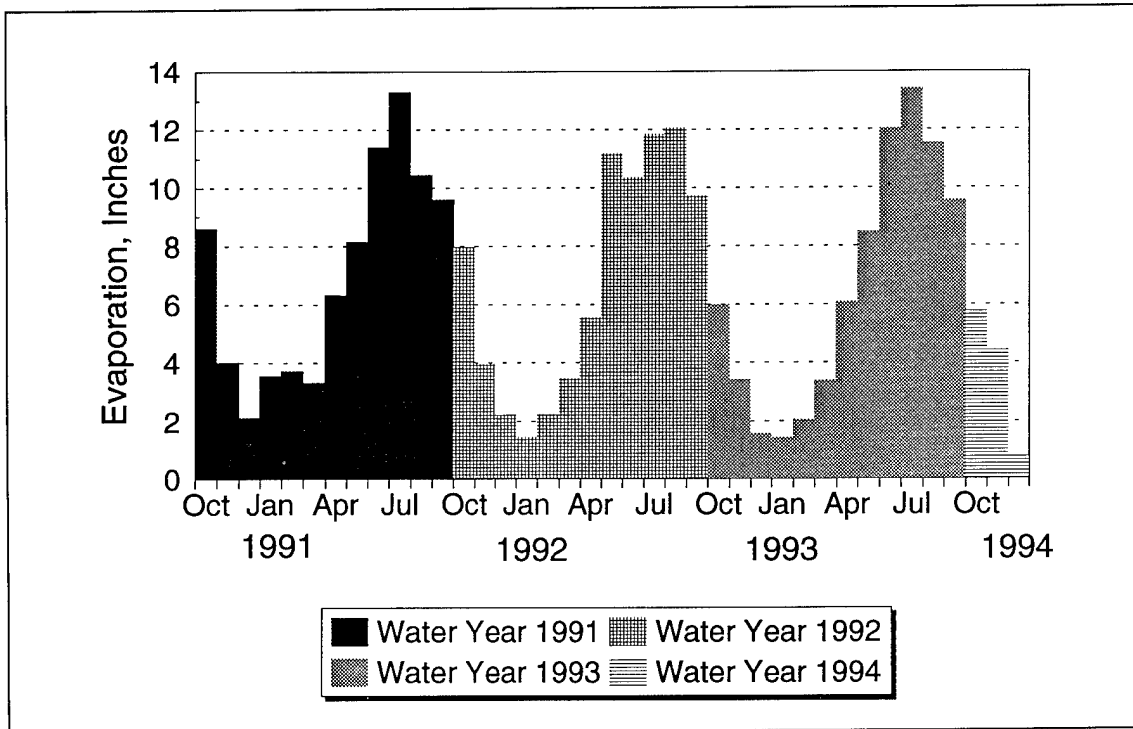

Figure 13. Monthly pan evaporation at Black Butte Reservoir

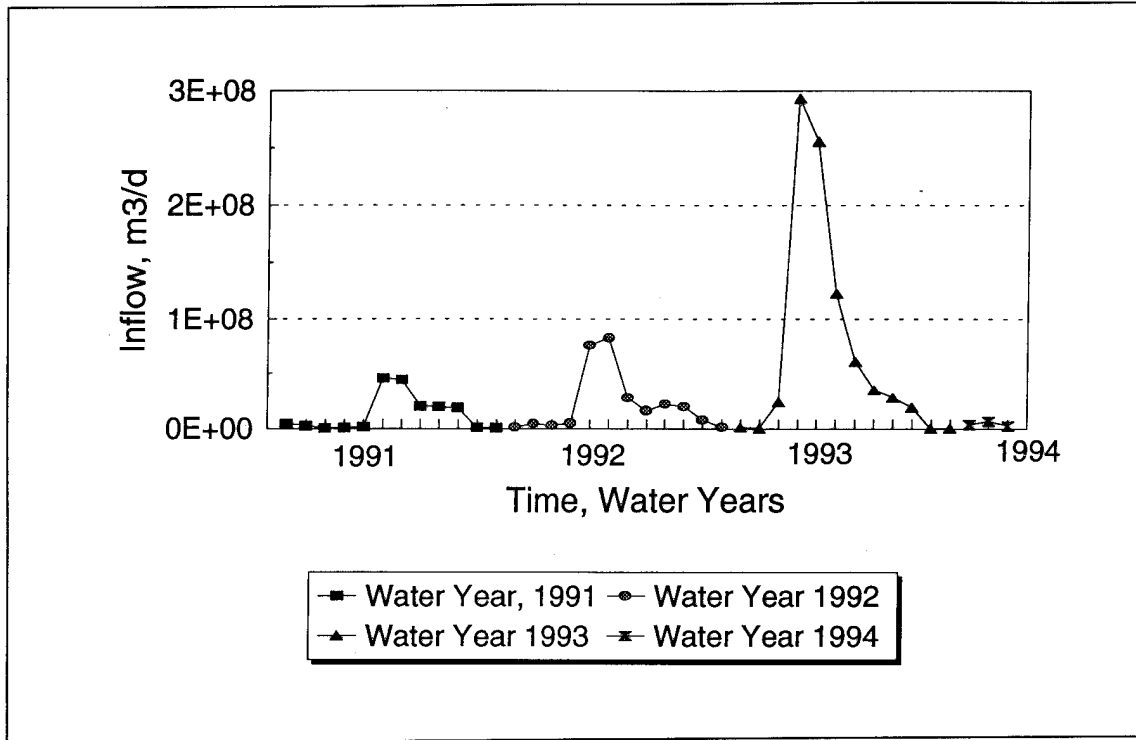

Figure 14. Black Butte Reservoir inflows

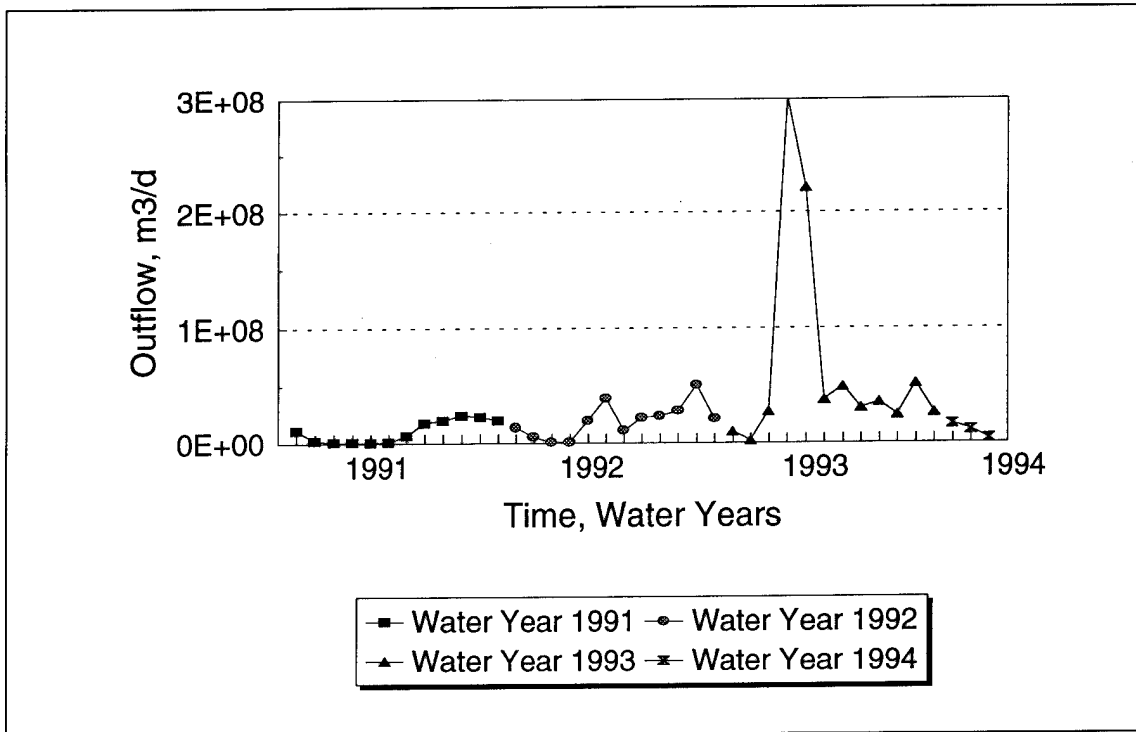

Figure 15. Black Butte Reservoir outflows

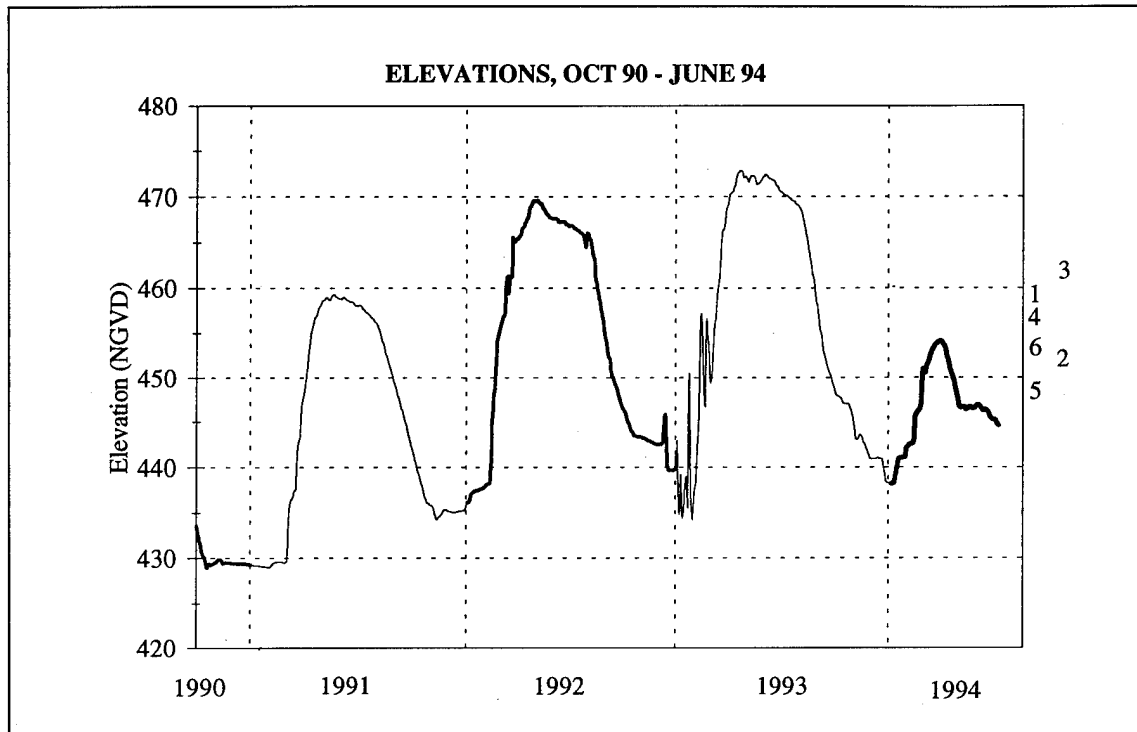

Figure 16. Black Butte Reservoir water surface elevations

elevation of the six wetlands are shown on the right-hand side of Figure 16. As described earlier, the wetland construction was complete in February 1992. Since their construction, the wetlands have been inundated much of the time. Unusually heavy rainfall and a resulting reduction in the need for irrigation water resulted in unusually high summer water levels. Because of this, the wetlands were inundated for much of the summer growing seasons in 1992 and 1993. Water levels in 1994 more closely mimicked "normal" pool operations. The water levels for 1994 were slightly below the rule curve. Only Wetlands 2 and 5 were inundated by the lake during 1994. The history of inundation of each of the wetlands is shown in Table 5. The wetland is considered inundated once the lowest place on the dike, the spillway, is below the reservoir water surface elevation.

Wetland water levels and flows

As previously described, water-level monitoring equipment was not installed in the wetlands until 1994. No detailed water level or flow data are available for 1992 and 1993. During these 2 years, the wetlands were inundated by the reservoir for much of the growing season (Figure 16, Table 4). Prior to inundation by the reservoir, the wetlands were filled with January precipitation and runoff. Significant overflows occurred during late January and February of 1993. Once the lake receded, after several months of inundation by the lake, the wetlands held water for only a few days. Although

Wetland	1992 Dates	1992 Number of Days	1993 Dates	1993 Number of Days	1994 Dates	1994 Number of Days	Total Number of Days
1	3/6 - 8/17	165	3/10 - 8/25	169	None	None	334
2	2/19 - 9/6	201	2/8 - 2/14 2/19 - 2/24 3/2 - 9/11	207	3/2 - 4/6	36	444
3	3/9 - 8/11	156	3/13 - 8/21	162	None	None	318
4	2/27 - 8/24	180	2/9 - 2/12 2/20 3/7 - 8/31	183	None	None	363
5	2/15 - 9/25	224	1/21 - 1/24 2/8 - 2/15 2/18 - 10/6	244	2/20 - 4/21	62	530
6	2/20 - 8/31	194	2/9 - 2/13 2/19 - 2/23 3/4 - 9/6	197	3/9 - 4/1	24	415

evaporative losses were high, on the order of 1 cm/day, they do not explain the rapid loss of water from the wetlands. Seepage losses must account for the additional water losses. Measured wetland water levels and flows for 1994 are discussed below.

Wetland 1. The 1994 water levels in Wetlands 1 are shown in Figure 17. Wetland 1 was not inundated by the reservoir during 1994. Heavy rainfall on February 6 and 7 caused enough runoff to nearly fill the wetland, leaving 0.304 m (1.0 ft) of water in the wetland. Because of large seepage losses, the wetland was dry by midday on February 8 (Figure 17). A similar rainfall event occurred on February 17, but again, large seepage losses left the wetland dry 2 days later. No significant rainfall events occurred after this date except in late April, which left water in the wetland for only a few days. The wetland was dry for the rest of the summer. No overflows from the wetland occurred during the 1994 monitoring period. Seepage losses from the wetland are estimated at 0.39 m/day (1.27 ft/day).

Wetland 2. Water surface elevations in Wetland 2 are shown in Figure 18. Wetland 2 was partially filled by early February rains. The rising lake water level kept seepage losses from Wetland 2 small during February. As described earlier, Wetland 2 was inundated by the reservoir from March 2 until April 4. Once the lake receded, water loss as a result of seepage began, slowly at first, and then faster as the lake receded. A late April rain delayed the eventual drying of the wetland. Wetland 2 held water until the first of May. There were no outflows from Wetland 2 in 1994. The peak seepage rate from the wetland is estimated at 0.064 m/day (0.21 ft/day).

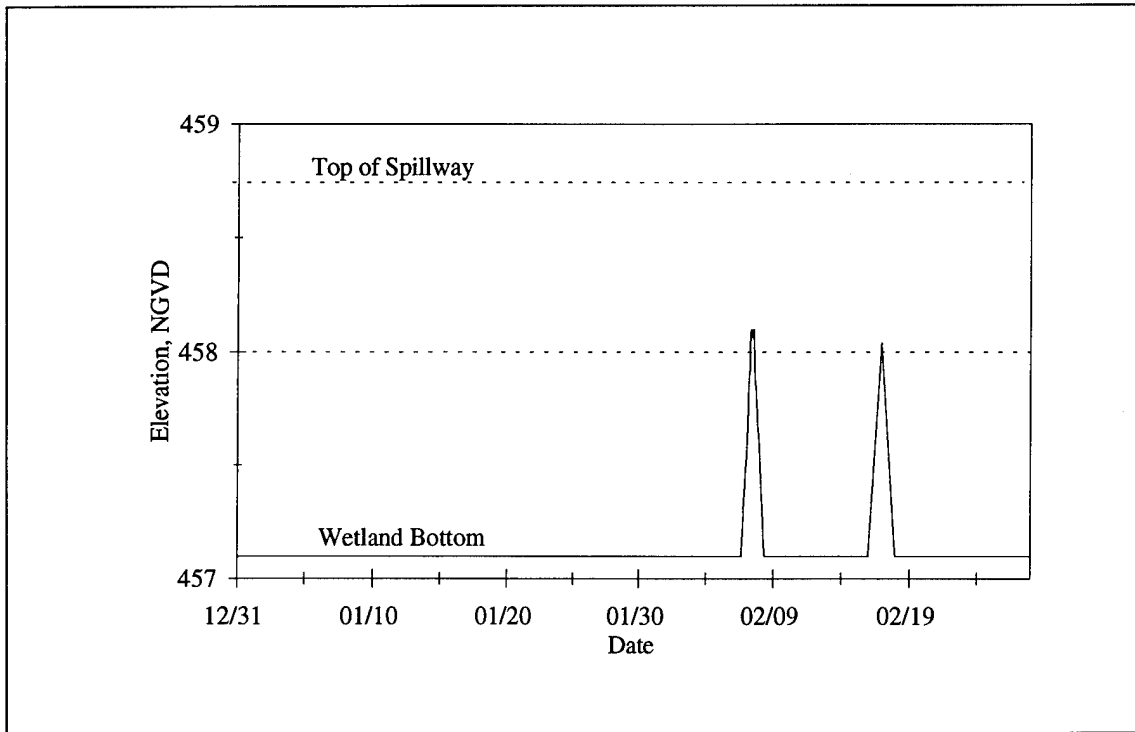

Figure 17. Wetland 1, 1994 water surface elevations

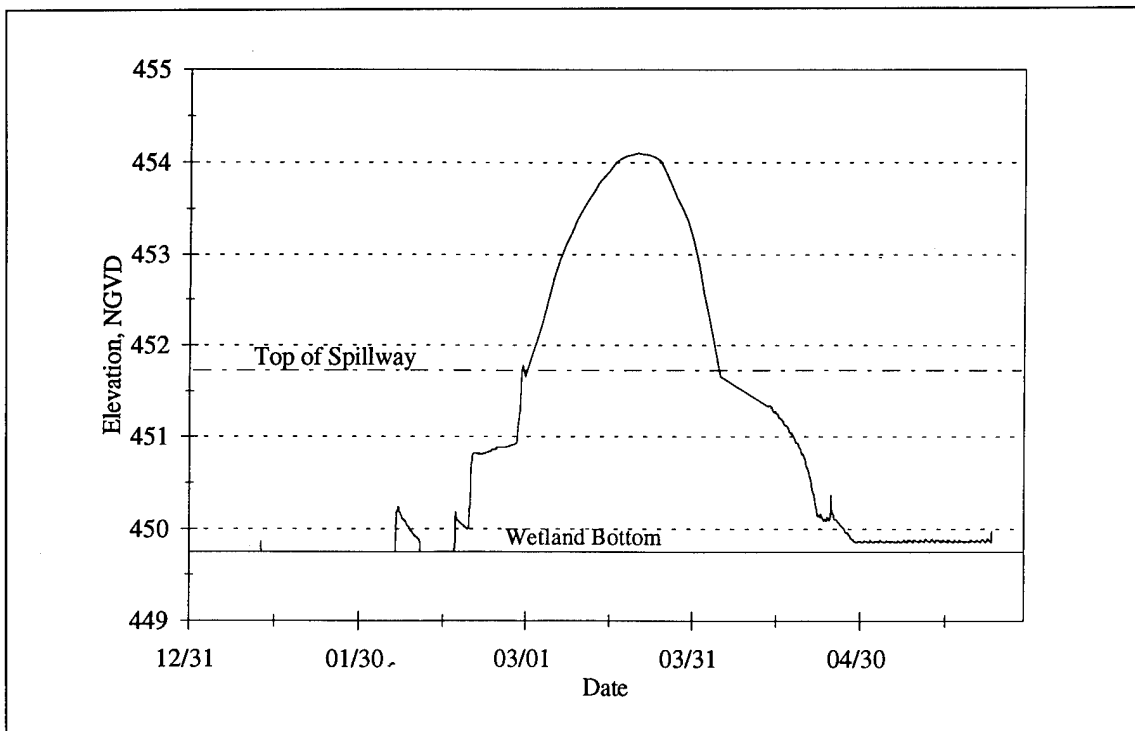

Figure 18. Wetland 2, 1994 water surface elevations

Wetlands 3-6. Observed wetland water surface elevations for Wetlands 3-6 are shown in Figures 19-22. The water levels in Wetlands 3, 4, and 6 followed a similar pattern. Late January precipitation filled the wetlands. Frequent rainfall events in February kept the wetlands full and caused small overflows from the wetlands. Once the frequency of rainfall lessened, the wetland water level quickly dropped; the wetlands were dry in early March. Seepage losses from Wetlands 3, 4, and 6 are estimated at 0.057 m/day (0.19 ft/day), 0.033 m/day (0.11 ft/day), and 0.042 m/day (0.14 ft/day), respectively. Wetland 5 was filled in late January, but was inundated by the lake from February 20 to April 21 (Figure 21).

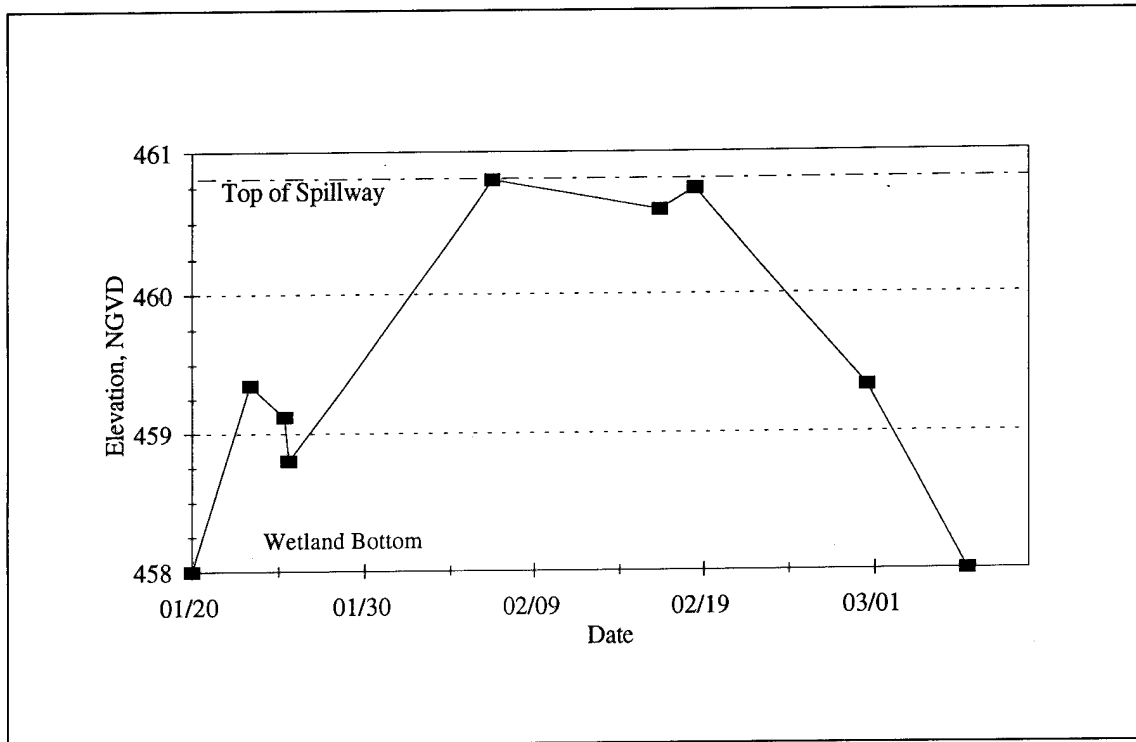

Figure 19. Wetland 3, 1994 water surface elevations

Peak crest gauge elevations and estimated flows from Wetlands 3-6 are shown in Table 6. Estimates of peak flows are crude but indicate the general magnitude of flows over the spillways. Peak flows were on the order of 0.1 to 0.2 m³/s (3.5 to 7.0 cfs).

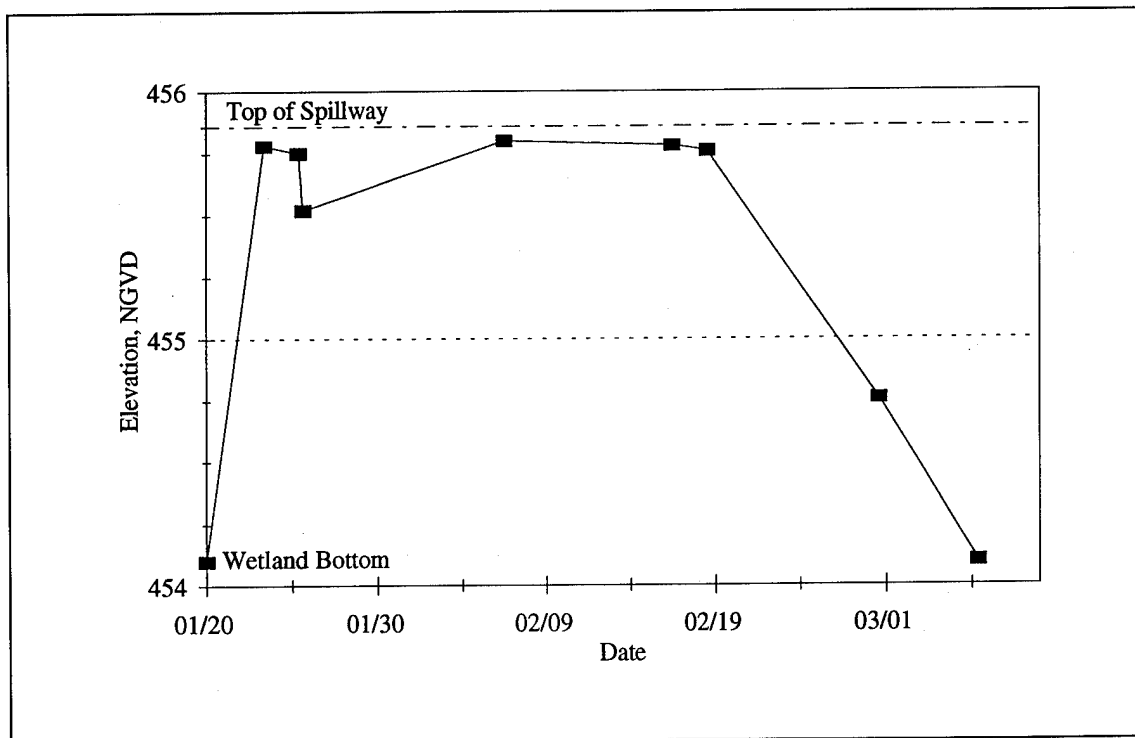

Figure 20. Wetland 4, 1994 water surface elevations

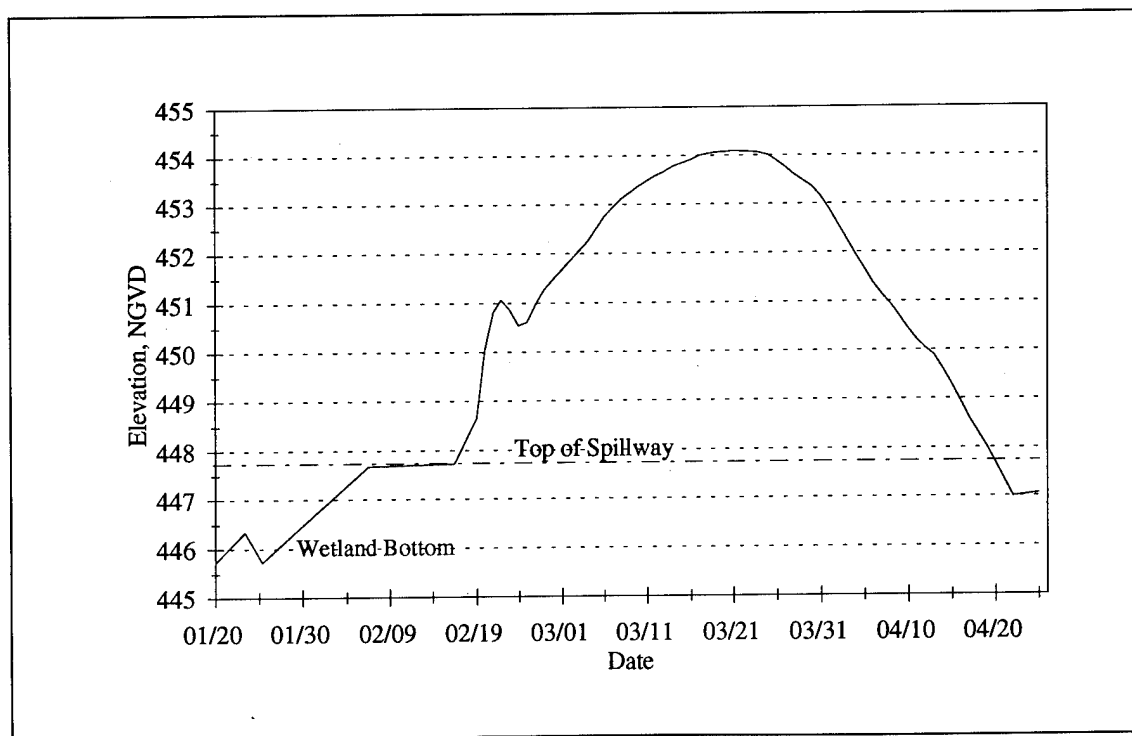

Figure 21. Wetland 5, 1994 water surface elevations

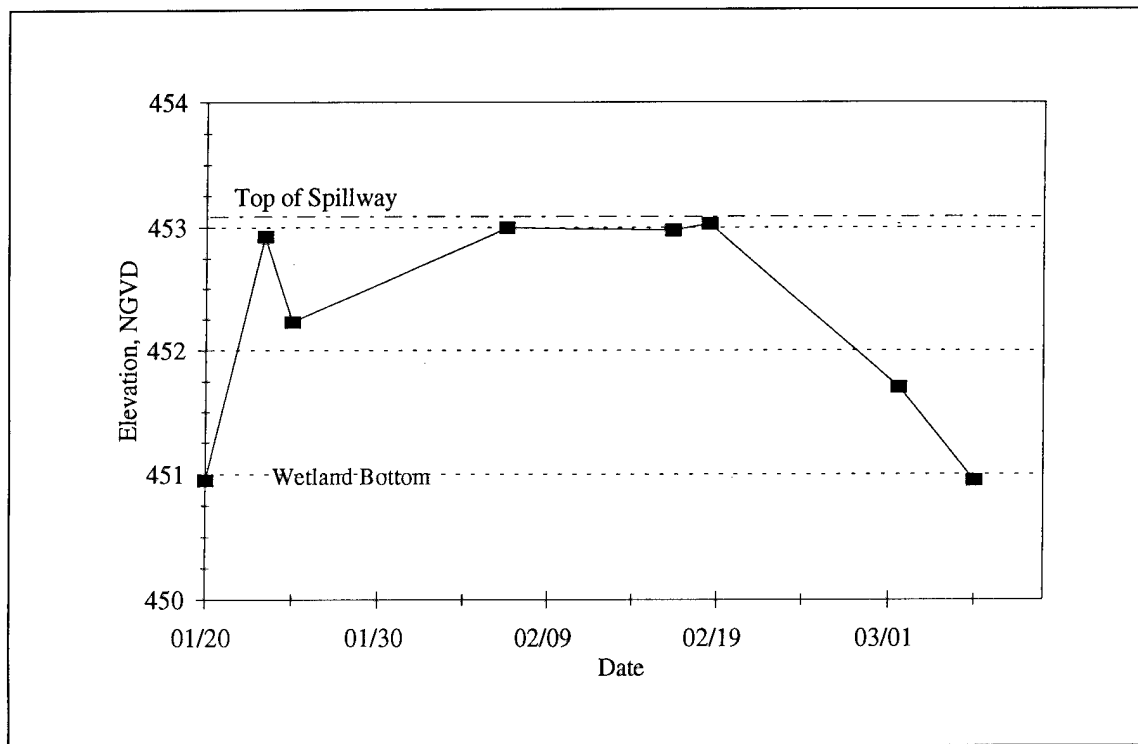

Figure 22. Wetland 6, 1994 water surface elevations

Table 6 Peak Water Surface Elevations and Flows, Wetlands 3-6								
Date	Wetland 3		Wetland 4		Wetland 5		Wetland 6	
	PWSE NGVD ft	Pflow m ³ /s	PWSE NGVD ft	Pflow m ³ /s	PWSE NGVD ft	Pflow m ³ /s	PWSE NGVD ft	Pflow m ³ /s
1/24	459.4	0	455.8	0	446.38	0	453.07	0
1/26	459.31	0						
2/7	460.83	0.05	455.97	0.2	448.01	0.2	453.20	0.1
2/17	460.68	0	455.88	0.05	447.81	0.1	453.12	0.05
3/1	460.94	0.1	455.92	0.1			453.20	0.1

Note: PWSE = peak water surface elevation; Pflow = peak flow.

Sediments

Suspended sediments

The results of TSS monitoring of wetland inflows, outflows, and standing water in Wetlands 1, 2, and 3 are shown in Table 7. Where only one concentration value is given, no outflow was occurring. As seen in Table 7, the wetlands were capable of significantly reducing the suspended sediment concentration of high TSS concentration inflows. Removal efficiencies were as high as 93 percent. As the wetland inflow TSS concentration was reduced, removal efficiency was reduced. At very low inflow concentrations, 10 mg/ℓ or less, no TSS removal occurred.

Sample Date	Wetland 1		Wetland 2		Wetland 3	
	Inflow Concentration (mg/ℓ)	Outflow Concentration (mg/ℓ)	Inflow Concentration (mg/ℓ)	Outflow Concentration (mg/ℓ)	Inflow Concentration (mg/ℓ)	Outflow Concentration (mg/ℓ)
1/07/93	270	20	40	30	290	60
1/13/93	10	10	140	60	10	50
1/20/93	20	10	140	80	20	50, 80
1/21/93	230	20	250	60	160	70
2/09/93	20	10	80	250	10	390
2/11/93	10	10	80	250	10	90
2/18/93	10	5	20	230	10	140
2/19/93	10	10	40	150	10	220
2/24/93	10	10	400	30	10	30
2/26/93	<5	50	80	30	<5	30
2/17/94			80		30	
2/23/94			50		20	
3/04/94			6		<5	
3/11/94			110		<5	

In Wetlands 2 and 3, erosion of the outlet spillways became a problem. This is reflected in the outflow TSS concentration data at these sites, which was collected from the wetland spillway. Flows began to erode the sandbag spillways. Erosion was greatest when inflows had low TSS concentrations, increasing the sediment carrying capacity of the flows. The increased sediment load at the outflow of these wetlands did not seem to be caused by the

scour of bottom sediments. Sediment accretion measurements also bear this out.

Sediment accumulation

A summary of results of sampling the feldspar pads and sediment disks in each of the wetlands is shown in Table 8 below. The data from each sampling station are shown in Table 9.

Wetland Number	1992 Average Pad Depth mm	1992 Average Areal Accumulation kg/m ²	1992 Average Volatile Fraction %	1992 Average Volatile Accumulation kg/m ²	1993 Average Pad Depth mm	1993 Average Disk Depth mm	1993 Average Areal Accumulation kg/m ²	1993 Average Volatile Fraction %	1993 Average Volatile Accumulation kg/m ²
1	23.0	24.3	9.3	2.24	22.4	14.9	10.9	11.2	1.78
2	31.2	38.7	7.1	2.52	34.6	24.8	23.1	8.2	1.52
3					14.5	5.6	2.02	7.5	0.19
4					14.9	39.8	2.12	8.2	0.17
5					50.7	45.5	42.5	7.5	4.5
6						89.2	3.26	7.0	0.23

1992 Sampling. For Wetland 1, measurements of depth of sediments on the feldspar pads ranged from 9 to 36 mm (Table 9). Two of the pads could not be found. The average sediment accumulation for Wetland 1 is 23 mm for the six pads located. Pads located on the very edge of Wetland 1, near the same elevation as the outlet weir, contained very little sediment. The two control pads for Wetland 1, located outside the wetland, could not be found. Areal sediment accumulation in Wetland 1 averaged 24.0 kg/m².

For Wetland 2, sediment depth measurements on the feldspar pads ranged from 25 to 40 mm with an average of 31 mm. There was no apparent correlation between sediment depth and pad elevation or position. The two control pads, 9 and 10, located outside the wetland, had sediment depths of 31 and 20 mm, respectively. Control 9 is closer to Burris Creek and at a lower elevation than the wetland. Control 10 is at a higher elevation and near the east end of the dike. Areal sediment accumulation average 39.5 kg/m² in Wetland 2.

The volatile organic portion of the sediments was 9.2 percent for Wetland 1 and 6.5 percent for Wetland 2. The mass accumulation of organic sediments was 2.24 kg/m² for Wetland 1 and 2.56 kg/m² for Wetland 2.

Table 9 Sediment Sampling Data												
Wetland Number	Sample Site	Elevation NGVD	1992 Feldspar Sediment mm	1992 Mass Accumulation g/m ²	1992 Volatile Fraction	1992 Mass Volatile Sediment g/m ²	1993 Feldspar Sediment mm	Old Pad Depth mm	1993 Disks Sediment mm	1993 Mass Accumulation g/m ²	1993 Volatile Fraction	1993 Mass Volatile Sediment g/m ²
1	1	459.71					26.6		21.5	16,134	12.9	2,081
1	2	459.50	19				15.7	29.6	8.4	4,923		
1	3	459.96							8.6	5,717		
1	4	458.00	20	15,941	0.09	1,479	29.8	46.3				
1	5	458.75					14.5		11.2	8,498	12.3	1,045
1	6	459.77							5.1	2,647		
1	7	458.68	36	27,157	0.11	2,971	18.7	35.5	9.4	5,292		
1	8	458.61	9				20.5	40.3	21.1	16,991		
1	9	457.47	26	28,170	0.09	2,394	30.8	53.6				
1	10	457.32	29	25,896	0.08	2,134		64.2	34.2	27,140	8.2	2,217
1	11	456.54										
2	1	450.92	25	31,665	0.07	2,239	26.1		16.4	12,003	8.6	1,035
2	2	450.56	40	47,077	0.07	3,291	45.3		40.7	35,335		

(Continued)

Table 9 (Concluded)

Wetland Number	Sample Site	Elevation NGVD	1992 Feldspar Sediment mm	1992 Mass Accumulation g/m ²	1992 Volatile Fraction	1992 Mass Volatile Sediment g/m ²	1993 Feldspar Sediment mm	Old Pad Depth mm	1993 Disks Sediment mm	1993 Mass Accumulation g/m ²	1993 Volatile Fraction	1993 Mass Volatile Sediment g/m ²
2	3	450.62	28	46,181	0.06	2,974	37.1		28.2	26,836		
2	4	450.54	30	35,543	0.07	2,317	23.7		16.3	11,842		
2	5	450.71	31	37,738	0.06	2,404	31.3		32.4	28,937		
2	6	450.18	29	33,199	0.06	2,025	37.8		14.3	14,707		
2	7	447.68	31				39.4		24.2	22,825		
2	8	450.28	35	39,949	0.06	2,417	36.4		25.8	25,580	7.8	2,005
2	9	449.03	31	44,267	0.06	2,824	32.2		15.3	3,494	7.6	265
2	10	453.93	20				23.0		6.9	16,652	9.0	1,502
3	1	460.2					10.7		6.2	1,513		
3	2	458.4					18.3		5.0	2,485	7.5	187
4	1	455.2					14.9		50.8			
4	2	455.2							5.0	2,118	8.2	174
4	3	455.7							63.5			
5	1	447.5					50.7		36.1	24,562	7.5	1,852
	2	444.8							54.8	60,384	7.5	4,523
6	1	453.4							7.0	3,262	7.0	227
	2	452.1							171.4			

1993 Sampling. For Wetland 1, 7 of the 10 feldspar pads and 8 of the 10 sediment disks were located. Average sediment accretion on the feldspar pads was 22.3 mm. The measurements ranged from 14.5 to 30.8 mm. Average sediment accretion on the plexiglass disks was 14.9 mm and ranged from 5.1 to 34 mm. Areal accumulation, as measured on the plexiglass disks, averaged 10.9 kg/m². The sediments were 11.2-percent organic material, equating to an organic areal sediment accumulation of 1.78 kg/m². Six of the old feldspar pads from 1991 were located under the newer pads. The average accumulation on these pads was 44.9 mm and ranged from 29.6 to 64.2 mm. Two control pads were located outside of the wetland. Of the two, only control site 9 was found. Sediment accretion at this site was measured as 33.7 mm on the feldspar pad and 30.2 mm on the plexiglass disk.

In Wetland 2, all eight of the sediment pads and disks were located. Average sediment accretion in Wetland 2 was 35.2 mm on the feldspar pads and 24.9 mm on the plexiglass disks. Measurements ranged from 24.7 to 45.3 mm on the feldspar pads and from 14.3 to 40.7 mm on the plexiglass disks. Areal accumulation on the plexiglass disks averaged 23.1 kg/m² in Wetland 2. Average organic content of these sediments was 8.2 percent. The areal accumulation of organic sediments on the plexiglass disk was 1.52 kg/m². Two control sites located outside of the wetland accumulated 27.6 mm on the feldspar pads and 11.1 mm of sediment on the plexiglass disks.

Two feldspar pads and sediment disks were placed in Wetland 3. The average depth on the pads was 14.5 mm, and the average depth on the disks was 6.1 mm. The average areal accumulation on the disks was 2.07 kg/m².

Three pads and disks were placed in Wetland 4. Only one of the pads, number 2, was located and it had a average accretion of 14.9 mm. The corresponding depth of sediments on the plexiglass disk was 5.0 mm. The other two disks, 1 and 3, were deeply buried under 2 and 2.5 in. (50.8 and 63.5 mm) of sediments, respectively. The disks could not be removed while retaining the sediments because the sediments were loose. The depth of sediments above each of these pads was measured with a ruler by pushing the ruler through the sediments until the ruler contacted the plexiglass disk and then reading the ruler at the ground surface. The sediments above disk 1 were loose, clumpy, and contained a lot of debris. The sediments on disk 1 appeared to be made of fine cohesive materials. However, on disk 3, the sediments consisted mostly of large sands and fine gravels.

Wetland 5 is located immediately downstream of Wetland 6. Two pads and disks were placed in this wetland. One of the pads and both of the disks were found. Pad 2 had 50.7 mm of accumulated sediments, whereas disks 1 and 2 had 36.1- and 54.8-mm accumulation, respectively. The average sediment accretion on the disks was 45.4 mm. On pad 1 and disk 1, located near the outlet dike, the sediments consisted of fine cohesive silts and clays. Below the dam, on the lake side, several feet of sand and gravel had accumulated. It appears that erosion from the steep banks surrounding the area is

being piled up at the entrance to the cove by wave action. The wetland dike is preventing the large particles from moving into the cove, but not the finer silts and clays. This may explain why large amounts of fine sediments have accumulated near the dike in the wetland. The fine sediments may also be washed down from Wetland 6 above.

Two disks were located in Wetland 6. Neither of the two feldspar pads could be located. Disk 6, near the upstream end, accumulated 7.0 mm of sediment. Disk 7, near the dike, accumulated 6.75 in. (171.4 mm) of sands and gravels, as measured with the ruler.

Analysis and discussion. Hydrologic conditions during 1992 and 1993 were nearly the same, with high spring rainfall and inflows and sustained inundation of the wetlands by the reservoir. Sediment accretion values as measured on the feldspar pads in Wetlands 1 and 2 did not vary significantly between years. Estimated areal sediment accumulation values were much lower for 1992 than for 1993. This is probably attributable to differences in measurements between the feldspar pads and the plexiglass disks. See discussion below on the differences between measurement techniques.

Sediment accretion/accumulation rates in the wetlands was much higher than values recorded in other freshwater and saltwater wetlands, which are typically less than 10 mm per year. In Johnston (1991), a compilation and analysis of sediment and nutrient retention data in freshwater wetlands, the highest recorded accretion rate was 2 cm/year, and the highest mass accumulation rate was 7.84 kg/m²/year. None of the wetlands reported in Johnston (1991) were located within the fluctuation zone of reservoirs, as are the wetlands at Black Butte Lake.

Wetlands located in the fluctuation zone of the reservoir are subjected to a variety of sediment sources. Sediment sources for Wetlands 1 and 2 are from runoff, Burris Creek overflow, and from lake backup. Sediment sources for Wetlands 3-6 are primarily from runoff and from lake inundation. The variety of sources of sediments complicates the sedimentation patterns in the wetlands. Sampling of inflows and outflows from Wetlands 1, 2, and 3 indicated that incoming sediment loads in runoff are potentially high with TSS concentrations as high as 400 mg/l, and that removal efficiencies are also high, up to 93 percent, during these high TSS loading events. Therefore, the runoff from the drainage basin above the lake represents a significant source of sediments to the wetlands. Erosion along the fringes of the lake may also contribute to this source and apparently is responsible for large volumes of coarse sediments being deposited in the smaller wetlands.

A summary of sedimentation patterns in Black Butte Lake, as determined by the May 1984 resurvey of the reservoir by the Sacramento district, is presented in Table 10 and represents sedimentation in the reservoir since its construction in 1963. The top of the spillway is at elevation 473.5 NGVD; the lowest elevation in the lake is at 374.5 NGVD. Total sediment accumulation in the lake since 1963 has been 770 acre-ft. As shown in Table 10

Table 10
Sedimentation Patterns in Black Butte Reservoir

Elevation ft NGVD	Area acres	Change in Area acres	% of Total Sediment	Sediment Volume acre-ft	Sediment Accretion cm	Accretion Rate mm/year
483.5	5,312	795	2	15	0.6	0.3
473.5	4,518	732	3	23	1.0	0.4
463.5	3,785	633	11	85	4.1	1.8
453.5	3,153	690	6	46	2.0	0.9
443.5	2,463	604	13	100	5.1	2.2
433.5	1,860	574	15	116	6.1	2.7
423.5	1,286	529	24	185	10.6	4.6
413.5	757	369	6	46	3.8	1.7
403.5	388	197	9	69	10.7	4.7
393.5	191	152	5	39	7.7	3.4
383.5	39	39	6	46	35.7	15.5
374.5	0	0				
Average					7.94	3.46

long-term sedimentation rates in the fluctuation zone of the reservoir have been on the order of 2 mm/year, an order of magnitude lower than the rate observed in Wetlands 1 and 2. This value represents the long-term average that includes many years of very little inflows. Thus many years of small sediment loading are included in this average. Since 1992 and 1993 were years of high inflows and sustained flooding, sediment deposition in the lake could have been much higher than the long-term average. The measurements from the control pads near Wetlands 1 and 2 seem to indicate that sedimentation in the reservoir was high during these years. Although limited data exist comparing the sedimentation rates in the wetlands to nearby lake sedimentation rates, these data suggest that little difference exists between the two. For Wetland 1, the one control point that could be located had significantly higher sediment accumulations than did the wetland as a whole. The control point was located in a low area where fill was taken to construct the dike. Comparisons with sampling sites 8, 9, and 10 (which also represent low spots in the wetland) are probably better and more closely approximate environmental conditions. These sites had approximately the same accumulation rates as the control pad.

For Wetland 2, the combined control average is significantly less than the wetland average. Site 9, at which the elevation more closely approximates that of the wetland, has the same approximate accumulation rate. Site 10,

located on a high area that is 1.9 ft higher than the dike, had an accumulation rate approximately 10 mm/year lower than the wetland average. This information suggests that local elevation changes had a greater effect on sedimentation than the dikes did.

To test the hypothesis that accretion rates of sediments at the sampling sites were related to elevation, several least-squares linear regression analyses of the data were conducted. Elevation (NGVD) was the independent variable for all regression analyses. Analyses were conducted using Quattro Pro 5.0 software.¹ A summary of these analyses are shown in Table 11 below.

Table 11 Elevation and Accretion/Accumulation Linear Regression Models				
Dependent Variable	Intercept	X	R²	Standard Error
1992 Sediment Accretion on Feldspar Pads, mm	490.52	-1.02	0.30	6.59
1993 Sediment Accretion on Feldspar Pads, mm	853.29	-1.82	0.64	6.63
1992 and 1993 Sediment Accretion on Feldspar Pads, mm	717.51	-1.52	0.51	6.68
1993 Sediment Accretion on Plexiglass Disks, mm	965.86	-2.07	0.08	32.27
1992 Sediment Accumulation on Feldspar disks, kg/m ²	953.64	-2.03	0.66	0.46
1993 Sediment Accumulation on Plexiglass Disks, kg/m ²	847.59	-1.83	0.41	10.99
1992 Organic Content on Feldspar Pads, %	-162.90	3.76	0.85	6.13
1993 Organic Content on Plexiglass Disks, %	-101.58	0.24	0.38	1.59
1992 Organic Areal Accumulation on Feldspar Pads, kg/m ²	20.47	-0.04	0.09	0.49
1993 Organic Areal Accumulation on Plexiglass Disks, kg/m ²	51.30	-0.11	0.18	1.19

Figure 23 shows sediment accretion on the feldspar pads for 1993 versus the elevation of the pads. The least squares fit linear regression line is also shown in the figure. The data and regression indicate a trend of increasing sediment accretion with decreasing elevation. The regression equation, as shown Table 10, was as follows:

$$\text{Sediment Accretion (mm)} = 853.29 - 1.82 \text{ Elevation (NGVD)}$$

¹ Quattro Pro 5.0 is a product of Borland, Scotts Valley, CA.

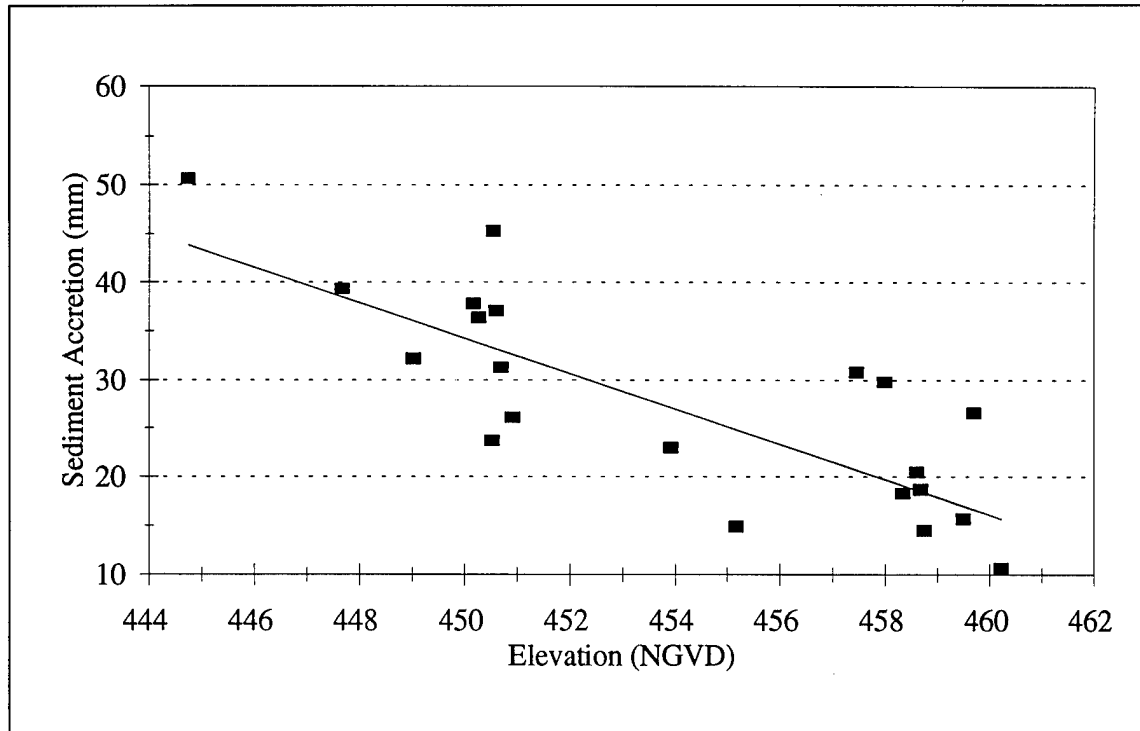

Figure 23. Data and regression from 1992 feldspar pad sampling of Wetlands 1 and 2

The Correlation Coefficient (R^2) value was 0.64, indicating that a trend in the data does exist. A regression of the 1992 data produced an R^2 value of only 0.30. All accretion/accumulation data showed similar trends of increasing sedimentation at lower elevations. The trend between mass accumulation on the feldspar pads and elevation for 1992 was stronger, $R^2 = 0.66$, than the trend for sediment accretion. A regression of all 31 data points of accretion (millimeters) on the feldspar pads from 1992 and 1993 versus elevation (NGVD) yielded an R^2 of 0.51, indicating a weak relation between sediment accretion and elevation. While this analysis indicates that sediment accumulation is increasing with decreasing elevation, many other variables such as drainage basin characteristics and time of inundation also influence the sedimentation process. A plot of all sediment accretion data is shown in Figure 24.

A trend between organic content and elevation was observed. Organic content increased with increasing elevation. For 1992, a strong relationship between organic content on the feldspar pads and elevation was determined, $R^2 = 0.85$. Organic content as measured on the plexiglass disks in 1992 also showed the same trend, but the relationship was not as strong, $R^2 = 0.38$. There was no trend between mass accumulation of organic content with elevation for 1992 or 1993, $R^2 = 0.07$ and 0.18, respectively.

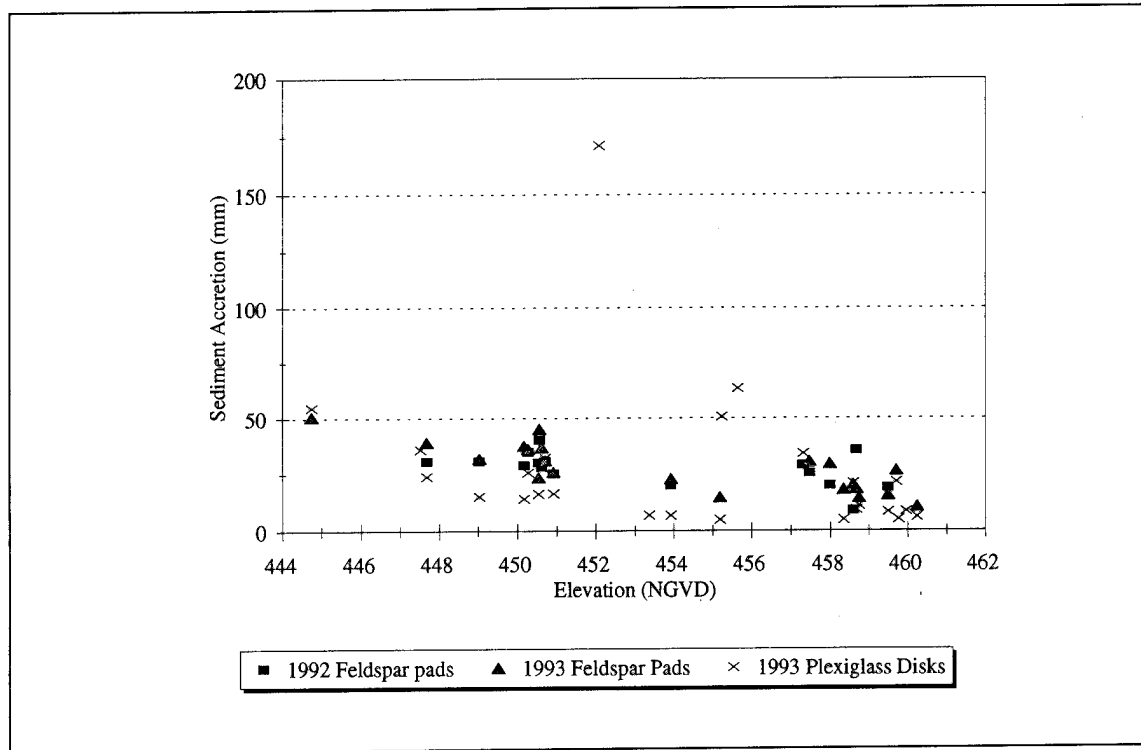

Figure 24. All sediment accretion data from Wetlands 1-6, 1992 and 1993

Differences in sediment accretion, accumulation, and organic content between different sites may be partially attributable to site differences between Wetlands 1 and 2, which are approximately 3 m different in elevation. Conducting Student's t-test to test the hypothesis that sediment accretion between Wetlands 1 and 2 was different indicated that the two accretion rates were significantly different at the 99-percent level on the feldspar pads for both 1992 and 1993. The Null Hypothesis (H_0) was that the two means were equal. The alternative hypothesis (H_A) was that the two means were different. The test was conducted using Quattro Pro software. The two-tailed significance levels (P) for 1992 and 1993 were 0.003 and 0.0013, respectively, indicating a less than 0.5-percent probability that the two data sets had the same mean. The differences in sediment accretion between the two wetlands as measured on the plexiglass disks were also significant, 0.0087.

Insufficient data were available to make meaningful statistical tests between the organic content of Wetlands 1 and 2, yet organic content was higher in Wetland 1 for both 1992 and 1993. Organic content also increased slightly in 1993, rising from 9.3 to 11.2 percent for Wetland 1 and 7.1 to 8.2 percent in Wetland 2. Wetland 1 had higher organic content than any of the other wetlands in 1993. Several reasons for the difference in organic content of the sediments between the wetlands could be hypothesized. Sources of sediments and vegetative composition are different at each site. Wetlands 2 through 6 are all located in regions of high bank erosion. This material is largely

inorganic. Wetland 1 has lush and more varied vegetation than the other wetlands.

Differences between measuring techniques. Measurements of sediment accretion at each site in 1993 were done with both feldspar pads and plexiglass disks. This was done to get a better measurement of sediment accretion and to compare measurements from the two techniques. As seen in Tables 7 and 8, measurements of sediment accretion on the plexiglass disks appear to be consistently lower than those made with the feldspar pads. A Student's-t test was conducted to test the hypothesis that the two measurement techniques yielded different results. In conducting the test, only data from sampling sites that had measurements from both feldspar pads and plexiglass disks were used. This resulted in paired data consisting of 19 sets. The mean value of measurements from the feldspar pads was 28 mm, and the mean value from the plexiglass disks was 19 mm. H_0 states that the two means were equal; H_A states that the two means were different, a two-tailed test. H_0 was rejected at the 99.9-percent significance level ($P = 0.00004$).

Observation indicates that measurements of sediment accretion or accumulation at identical sites using both feldspar pads and plexiglass disks are not the same. Standard statistical tests confirm this observation. The differences between the two measuring techniques probably account for most of the differences in estimated areal accumulations in Wetlands 1 and 2 between years 1992 and 1993. Areal accumulation was estimated from feldspar pad cores in 1992 and from plexiglass disks in 1993.

Several observations about the plexiglass disks were made during the 1993 sampling. The depth of sediments on the disks were higher on the edges than in the center. This effect seemed to be greatest for disks with high accumulation of very fine materials. In addition, disks with smaller amounts of sediments tended to lose part of the sediment after the sediment had dried and cracked. This was probably caused by wind and rain erosion of the sediments. The disks were slightly elevated above the natural ground surface. The problem may be partially alleviated by making the tops of the disks flush with the ground surface.

There were also problems in measuring sediment accretion on the feldspar pads. In pads located in Wetlands 1 and 2 with high accretion rates of fine materials, undulations occurred on the pads. The depth of sediments varied widely across these undulations, by more than a factor of two. In addition bioturbation caused significant blurring of the white marker horizon in many of the pads. This partially accounts for and contributes to the problems of local variations within the pads.

Given that there are problems in measuring sediment accretion with both techniques, it is difficult to determine which technique is best. In this study, it is believed that the feldspar pad measurements are more reliable because of the delay between drying of the ponds and sampling of the sites. The disks were more sensitive to this time lag because sediments on the disks are lost by

erosion once the disks are exposed. However, the disks provide a more reliable method for measuring sediment accretion in the small wetlands where high flow velocities cause the feldspar pads to be washed away.

Vegetation

No major vegetative changes occurred in the wetlands during the study. Wetland 1 had a mix of different grasses in the upper part of the wetland and was dominated by cocklebur near the dike. Wetland 2 was dominated by cocklebur over the entire wetland. Wetlands 3-6 were largely unvegetated, though some grasses and annual plants did occur. The dikes had little effect on this dominant vegetation. The combination of sustained flooding by the reservoir and rapid drying of the wetlands once the reservoir recedes prevents most wetland plants from occurring. Attempts to establish woody species that occur in other areas of the lake, such as black willow, were unsuccessful because of the sustained flooding during the study period. Plantings of such hearty species during years when the reservoir is operated closer to the rule curve may be more successful.

5 Conclusions

The wetlands constructed and monitored in this study demonstrate low-costs techniques to construct wetlands at USACE reservoirs. Constructing simple earthen dikes with passive outlet structures, as done on Wetlands 1 and 2, provides the most wetland area for the dollar. Protecting the outlet structures from wave erosion with air-blown mortar represented the bulk of the construction cost for these two wetlands. Not all projects will require such protection. Constructing protected dikes in gullies, as done for Wetlands 3-6, is less practical for creating large wetland areas because of the expense of protecting the dike from high-velocity overflows. Application of the techniques employed at this location should be tested at other USACE reservoirs.

Projected water balances in the wetlands were not achieved because of variations in operation of the reservoir and large seepage losses from the wetlands. Seepage rates may eventually slow in the larger wetlands. Water balances for proposed constructed wetlands should include accurate estimates of seepage if intended wetland functions are to be met. The failure to achieve the projected water balance is thought to be a primary reason for a lack of vegetation in the wetlands. The establishment of wetland vegetation may be more successful at other reservoirs with smaller and more predictable yearly water fluctuations.

The wetlands are effective sediment traps, capturing up to 93 percent of suspended sediments in inflows. The wetlands accreted several centimeters of sediment each year, far exceeding literature values for accretion of sediments in both constructed and natural wetlands.

Sediment accretion in the wetlands is thought to be highly dependent on reservoir conditions and operations. High sediment accretion in the wetlands is thought to be at least partially attributable to sustained inundation by the reservoir. Control sediment sites, located outside the wetlands, indicated that sediment accretion in the reservoir was also high. Differences in sediment accretion between the wetlands seem to be at least partially explained by the elevation of the wetland. Regression analysis yielded moderately strong relationships between sediment accretion and elevation of the sampling site. This relationship is probably due to frequency of inundation by the reservoir, which is dependent on elevation. In years where the reservoir is operated closer to the rule curve, the individual drainage basin of the wetlands will be

the primary sediment source, and sediment accumulation in the wetlands will be more dependent on drainage basin characteristics. Wetlands 3, 4, and 6, which accumulated large deposits of coarse material near the dikes, received most of their sediment load from their drainage basins.

Measurements of sediment accretion in 1993 using feldspar sediment pads and plexiglass disks were statistically different. The mean sediment accretions for paired data were 28 and 19 mm for the feldspar pads and plexiglass disks, respectively. Differences in the data sets are thought to be caused by losses of fine sediments from the disks after drying. The exposed sediments are subject to erosion from both wind and precipitation because the dry sediments do not adhere to the disks. Part of the problem may stem from the fact that the tops of the disks were slightly elevated above the ground surface. Measurements from the feldspar pads are thought to be better indicators of sediment accretion/accumulation in the large wetlands.

Vegetation composition in the wetlands did not change significantly over the life of the project. Attempts to establish willows and button brush in the wetlands failed because of sustained flooding. The wetlands should continue to be monitored to see that the habitat goals are met.

References

- American Public Health Association (APHA). (1975). *Standard methods for the examination of water and wastewater*. 14th ed., Washington, DC.
- Begg, E. L. (1968). *Soil survey of Glenn County, California*. United States Department of Agriculture, Soil Conservation Service, and Forest Service.
- Chow, V. T. (1959). *Open-channel hydraulics*. McGraw Hill Book Company, New York.
- Gowans, K. D. (1967). *Soil survey of Tehama County, California*. United States Department of Agriculture, Soil Conservation Service, and Forest Service.
- Johnston, C. A. (1991). "Sediment and nutrient retention by freshwater wetlands: Effects on surface water quality," CRC Critical Reviews in Environmental Control.
- Kleiss, B. A. (1993). "Methods for measuring sedimentation rates in bottomland hardwood (BLM) wetlands," WRP Technical Note SD-CP-4.1, U.S. Army Engineer Waterways Experiment Station, Vicksburg, MS.
- National Oceanic and Atmospheric Administration (NOAA). (1990). *Climatological data, annual summary, California 1990*. Volume 94, Number 13, Department of Commerce, National Oceanic and Atmospheric Administration, National Environmental Satellite, Data, and Information Service, National Climatic Data Center, Federal Building, Asheville, NC.
- United States Army Corps of Engineers (USACE). (1987). "Black Butte Lake," Orland, CA.

REPORT DOCUMENTATION PAGE

Form Approved
OMB No. 0704-0188

Public reporting burden for this collection of information is estimated to average 1 hour per response, including the time for reviewing instructions, searching existing data sources, gathering and maintaining the data needed, and completing and reviewing the collection of information. Send comments regarding this burden estimate or any other aspect of this collection of information, including suggestions for reducing this burden, to Washington Headquarters Services, Directorate for Information Operations and Reports, 1215 Jefferson Davis Highway, Suite 1204, Arlington, VA 22202-4302, and to the Office of Management and Budget, Paperwork Reduction Project (0704-0188), Washington, DC 20503.

1. AGENCY USE ONLY (Leave blank)		2. REPORT DATE August 1995	3. REPORT TYPE AND DATES COVERED Final report	
4. TITLE AND SUBTITLE Construction and Monitoring of Water and Sediments in Wetlands Created in the Black Butte Reservoir Fluctuation Zone, Orland, California			5. FUNDING NUMBERS	
6. AUTHOR(S) Charles W. Downer				
7. PERFORMING ORGANIZATION NAME(S) AND ADDRESS(ES) U.S. Army Engineer Waterways Experiment Station, 3909 Halls Ferry Road, Vicksburg, MS 39180-6199			8. PERFORMING ORGANIZATION REPORT NUMBER Technical Report WRP-SM-5	
9. SPONSORING/MONITORING AGENCY NAME(S) AND ADDRESS(ES) U.S. Army Corps of Engineers Washington, DC 20314-1000			10. SPONSORING/MONITORING AGENCY REPORT NUMBER	
11. SUPPLEMENTARY NOTES Available from National Technical Information Service, 5285 Port Royal Road, Springfield, VA 22161.				
12a. DISTRIBUTION/AVAILABILITY STATEMENT Approved for public release; distribution is unlimited.			12b. DISTRIBUTION CODE	
13. ABSTRACT (Maximum 200 words) Six wetland areas were constructed in the fluctuation zone of Black Butte Reservoir near Orland, CA, in November of 1991. The wetlands were to function as wildlife habitat and sediment traps. The wetlands ranged in size from less than 1 acre to approximately 3 acres for a total area of about 8 acres. The wetlands were constructed using simple low-cost techniques at an estimated cost of \$40,000 for materials and labor. Careful selection of sites aided in controlling construction costs. After construction, the wetland water levels and sediment accumulation were monitored. During the first 2 years of monitoring, the wetlands were inundated for much of the time, much longer than under normal conditions. During the last year of monitoring, the wetlands were inundated for a much shorter period, closer to normal conditions. Sediment accretion in all the wetlands was high, ranging from 5.6 to 89.2 mm/year (2.0 to 42.5 kg/m ²). Sediment accretion varied between wetlands, years, and measurement techniques. Sediment accretion in the wetlands also varied with elevation, with higher sediment accretion occurring at sites with lower elevations.				
14. SUBJECT TERMS Constructed wetlands Reservoir water quality Sedimentation			15. NUMBER OF PAGES 59	
			16. PRICE CODE	
17. SECURITY CLASSIFICATION OF REPORT UNCLASSIFIED	18. SECURITY CLASSIFICATION OF THIS PAGE UNCLASSIFIED	19. SECURITY CLASSIFICATION OF ABSTRACT UNCLASSIFIED	20. LIMITATION OF ABSTRACT	