

AL/EQ-TR-1994-0047



**FIELD EVALUATION OF AN ENVIREX GAC FLUID-BED BIOREACTOR
TREATMENT OF CHLOROBENZENE IN GROUNDWATER**

G.M. Klecka, S.G. McDaniel, P.S. Wilson, C.L. Carpenter, J.E. Clark

**Dow Chemical Company
Environmental Chemistry Research Laboratory
Health and Environmental Sciences
1803 Building
Midland MI 48674**

**ENVIRONICS DIRECTORATE
139 Barnes Drive, Suite 2
Tyndall AFB FL 32403-5323**

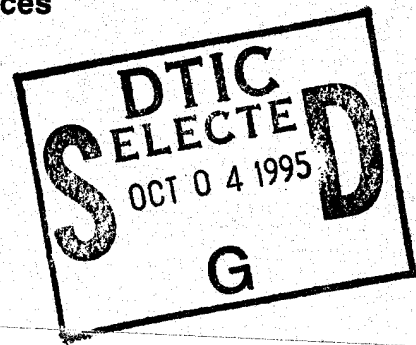

19950928 053

February 1995

Final Technical Report for Period June 1993 - February 1994

Approved for public release; distribution unlimited.

DTIC QUALITY INSPECTED 8

**AIR FORCE MATERIEL COMMAND
TYNDALL AIR FORCE BASE, FLORIDA 32403-5323**

**ARMSTRONG
LABORATORY**

NOTICES

This report was prepared as an account of work sponsored by an agency of the United States Government. Neither the United States Government nor any agency thereof, nor any employees, nor any of their contractors, subcontractors, or their employees, make any warranty, expressed or implied, or assume any legal liability or responsibility for the accuracy, completeness, or usefulness of any privately owned rights. Reference herein to any specific commercial products, process, or service by trade name, trademark, manufacturer, or otherwise, does not necessarily constitute or imply its endorsement, recommendation, or favoring by the United States Government or any agency, contractor, or subcontractor thereof. The views and opinions of the authors expressed herein do not necessarily state or reflect those of the United States Government or any agency, contractor, or subcontractor thereof.

When Government drawings, specifications, or other data are used for any purpose other than in connection with a definitely Government-related procurement, the United States Government incurs no responsibility or any obligation whatsoever. The fact that the Government may have formulated or in any way supplied the said drawings, specifications, or other data, is not to be regarded by implication, or otherwise in any manner construed, as licensing the holder or any other person or corporation; or as conveying any rights or permission to manufacture, use, or sell any patented invention that may in any way be related thereto.

This technical report has been reviewed by the Public Affairs Office (PA) and is releasable to the National Technical Information Service, where it will be available to the general public, including foreign nationals.

This report has been reviewed and is approved for publication.

ALISON THOMAS
Project Manager

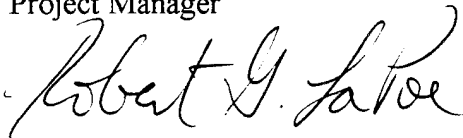
ROBERT G. LAPOE, Lt Col, USAF, BSC
Chief, Site Remediation Division

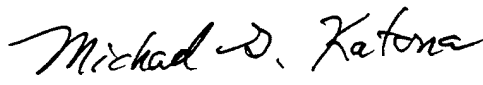
MICHAEL G. KATONA, PhD
Chief Scientist, Environics Directorate

NEIL J. LAMB, Colonel, USAF, BSC
Director, Environics Directorate

REPORT DOCUMENTATION PAGE**Form Approved
OMB No. 0704-0188**

Public reporting burden for this collection of information is estimated to average 1 hour per response, including the time for reviewing instructions, searching existing data sources, gathering and maintaining the data needed, and completing and reviewing the collection of information. Send comments regarding this burden estimate or any other aspect of this collection of information, including suggestions for reducing this burden, to Washington Headquarters Services, Directorate for Information Operations and Reports, 1215 Jefferson Davis Highway, Suite 1204, Arlington, VA 22202-4302, and to the Office of Management and Budget, Paperwork Reduction Project (0704-0188), Washington, DC 20503.

1. AGENCY USE ONLY (Leave blank)**2. REPORT DATE**
February 1995**3. REPORT TYPE AND DATES COVERED**
Final Report June 93 - February 94**4. TITLE AND SUBTITLE**

Field Evaluation of an Envirex GAC Fluid-Bed Bioreactor for Treatment of Chlorobenzene in Groundwater

5. FUNDING NUMBERS

Cooperative Research & Development Agreement (CRDA)

6. AUTHOR(S)

G.M. Klecka, S.G. McDaniel, P.S. Wilson, C.L. Carpenter and J.E. Clark

7. PERFORMING ORGANIZATION NAMES(S) AND ADDRESS(ES)Dow Chemical Company
Environmental Chemistry Research Laboratory
Health and Environmental Sciences
1803 Building
Midland MI 48674**8. PERFORMING ORGANIZATION
REPORT NUMBER**

N/A

9. SPONSORING/MONITORING AGENCY NAME(S) AND ADDRESS(ES)Armstrong Laboratory, Environics Directorate (AL/EQW)
139 Barnes Drive, Suite 2
Tyndall AFB FL 32404-5323**10. SPONSORING/MONITORING
AGENCY REPORT NUMBER**
AL/EQ-TR-1994-0047**11. SUPPLEMENTARY NOTES**

Availability of this Report is Specified on Reverse of Front Cover

12a. DISTRIBUTION/AVAILABILITY STATEMENT

Approved for Public Release

12b. DISTRIBUTION CODE**13. ABSTRACT (Maximum 200 words)**

Although granular activated carbon (GAC), fluidized-bed bioreactors have been widely used for treatment of groundwater containing readily biodegradable organic compounds, there is only limited experience with treatment of chlorinated organics found at many DOD and industrial sites. This report summarizes performance data from a field evaluation of an Envirex model 30 bioreactor operated at various chlorobenzene concentrations and organic loading rates over a 7-month period. The work was conducted under a collaborative research and development agreement between US Air Force Armstrong Laboratory and the Dow Chemical Company. Microorganisms used to seed the bioreactor were provided by activated sludge from the site, as well as indigenous chlorobenzene-degrading bacteria present in the groundwater. Removal efficiencies exceeding 99.99% were achieved at organic loading rates between 6 and 10 pounds of total oxygen demand (lb TOD) per 25 cubic feet per day and hydraulic residence times of 7 minutes. Influent chlorobenzene concentrations ranging from 100 to 170 ppm were consistently reduced to below the detection limit of 10 ppb. Additional studies conducted at loading rates in excess of 10 pounds TOD per 25 cubic feet per day were useful for identifying critical operating parameters and potential system improvements, but were not representative of performance at lower loadings. Economic evaluation suggested that groundwater treatment costs for the bioreactor were lower than other conventional technologies.

14. SUBJECT TERMS

fluid-bed bioreactor, chlorobenzene, biodegradation, groundwater, chlorinated solvents

15. NUMBER OF PAGES

91

16. PRICE CODE**17. SECURITY CLASSIFICATION
OF REPORT**

Unclassified

**18. SECURITY CLASSIFICATION
OF REPORT**

Unclassified

**19. SECURITY CLASSIFICATION
OF REPORT**

Unclassified

**20. LIMITATION OF
ABSTRACT**

UL

PREFACE

This report summarizes research activities conducted by Dow Chemical Company, Environmental Chemistry Research Laboratory with the Air Force Armstrong Laboratories Environics Directorate under a Cooperative Research & Development Agreement (CRDA) #93-03 "Field Evaluation of an Envirex GAC Fluid-Bed Bioreactor for Treatment of Chlorobenzene in Groundwater".

The work summarized in this report have been conducted by Gary M. Klecka (principal investigator), Steven G. McDaniel, Prentice S. Wilson, Constance L. Carpenter and James E. Clark of Dow Chemical Company, and Alison Thomas and Jim C. Spain of Armstrong Laboratory.

Accession For	
NTIS CRA&I	<input checked="" type="checkbox"/>
DTIC TAB	<input type="checkbox"/>
Unannounced	<input type="checkbox"/>
Justification	
By	
Distribution /	
Availability Codes	
Dist	Avail and/or Special
A-1	

(The reverse of this page is blank)

EXECUTIVE SUMMARY

Objective

The present study was conducted to evaluate the utility of an Envirex granular activated carbon (GAC), fluid-bed bioreactor to treat chlorobenzene-contaminated groundwater. Readily available sources of the microbial inoculum to be used during startup were identified. Performance of the bioreactor was examined over a range of operating conditions, including the effects of organic loading on effluent quality. Costs of groundwater treatment using the GAC fluid-bed bioreactor were compared with other conventional technologies.

Background

Bioreactors of this type are commercially available, and have been widely used for treatment of groundwater and process waters containing readily biodegradable aromatic hydrocarbons. Since pure oxygen is predissolved with the influent stream, such systems can be used to destroy volatile organic compounds because volatilization from the reactor is essentially eliminated. To date however, the application of bioreactors for treatment of chlorinated organic compounds has been limited, principally due to their perceived resistance to biodegradation. Recently, specialized microbial processes have been discovered, and it is now known that a variety of chlorinated aliphatic and aromatic hydrocarbons can be utilized by microorganisms as carbon sources for growth.

Scope

The work was conducted under a collaborative research and development agreement between the U. S. Air Force and The Dow Chemical Company. The field evaluation was conducted at an existing Dow manufacturing facility, where the groundwater has been previously shown to contain chlorobenzene, along with small amounts of aniline. During the field study, the GAC fluid-bed bioreactor was installed parallel to an existing air-stripper and thermal oxidizer system used for groundwater treatment.

Results

Performance of the reactor was examined over a 7-month period. Treatment efficiencies exceeding 99.99% were achieved at loading rates within the design capacity (6 to 10 pounds of total oxygen demand [lb TOD] per day) and hydraulic residence times of 7 minutes. Although chlorobenzene concentrations varied from 100 to 170 ppm, performance of the reactor was constant and effluent chlorobenzene concentrations were consistently reduced to below the detection limit of 10 ppb. At loading rates of 5 and 9 lb TOD/day, the ratio of oxygen consumption to the influent TOD concentration ranged from 0.93 to 0.99, suggesting that biodegradation was the principal removal mechanism. Volatilization from the reactor was negligible, as determined by periodic organic vapor analysis. Additional studies conducted at loading rates in excess of the design capacity were useful for identifying critical operating parameters and potential system improvements, but were not representative of performance at lower loadings.

Economic Analysis

A series of scenarios were developed for comparison of the costs of groundwater treatment using the GAC fluid-bed bioreactor with several conventional technologies, including liquid phase carbon adsorption, air stripping with vapor phase carbon adsorption, and air stripping with thermal oxidation. Of the technologies examined, the treatment costs for the bioreactor were generally lower. GAC fluid-bed bioreactor costs ranged from \$2.00 to \$13.00 per 1000 gallons and were dependent on the influent concentration, flow rate, and the possibility of additional charges for effluent disposal. Groundwater treatment by liquid-phase carbon adsorption was the most expensive (\$7.00 to \$27.00 per 1000 gallons) because of the costs for replacement and disposal of the spent carbon.

Conclusions

GAC fluid-bed bioreactors have been shown to achieve high treatment efficiencies and reliable performance. Although specialized strains of bacteria may be required in certain cases

during startup of a bioreactor, competent bacteria may be readily available at the site. The adsorption capacity of the biomass support serves to dampen the effects of load changes caused by moderate variability in groundwater composition or step changes in flow rate. However, performance of the system was affected by shock loading, resulting in transient excursions in effluent quality. The maximum organic loading capacity of the reactor is a function of the ability to provide sufficient oxygen for biodegradation. With the current injector, bubble trap and eductor system, the capacity is in the range of 6 to 10 lb TOD/day. A new bubble contactor, now being developed and tested by the manufacturer, may permit a 50 to 100% increase in loading.

Recommendations

GAC fluid-bed reactors have broad application for the treatment of groundwater and process waters containing a wide variety of organic compounds that can support microbial growth. In addition, specialized systems are currently being developed for treatment of nongrowth-supporting compounds. A number of minor improvements to the system were identified, many of which are currently available from the manufacturer.

(The reverse of this page is blank)

TABLE OF CONTENTS

SECTION	TITLE	PAGE
1.0	INTRODUCTION.....	1
1.1	Objectives	1
1.2	Background	1
2.0	ENVIREX BIOREACTOR DESIGN AND OPERATION.....	5
2.1	Process Fundamentals.....	5
2.2	System Components and Function.....	6
3.0	MATERIALS AND METHODS.....	10
3.1	Chemicals	10
3.2	Microbial Enrichment.....	10
3.3	Bioreactor Design and Operation.....	11
3.4	Analytical Methods.....	14
4.0	SITE DESCRIPTION.....	16
4.1	Current Site Remediation.....	16
4.2	Groundwater Characterization.....	17
5.0	RESULTS.....	19
5.1	Evaluation of Inoculum Sources.....	19
5.2	Bioreactor Performance Evaluation.....	22
	5.2.1 Startup.....	22
	5.2.2 Operation.....	23
5.3	Organic Loading and Treatment Efficiency.....	23
	5.3.1 Oxygen consumption and stoichiometry.....	28
	5.3.2 Nutrient requirements.....	32
	5.3.3 Growth and biomass yield.....	32
	5.3.4 pH control.....	34
	5.3.5 Volatile emissions.....	34
5.4	Effects of Shock Loading.....	36
5.5	Operation at Excess Loading.....	38
5.6	Effects of Temperature.....	42

SECTION	TITLE	PAGE
6.0	ECONOMIC ANALYSIS.....	45
6.1	Process Design	45
	6.1.1 Liquid-phase carbon adsorption.....	46
	6.1.2 Air stripping with vapor-phase carbon adsorption.....	46
	6.1.3 Air stripping with thermal oxidation	49
	6.1.4 GAC fluid-bed bioreactor treatment.....	51
6.2	Basis of Economic Analysis.....	51
6.3	Cost Categories.....	54
6.4	Treatment Costs.....	56
7.0	CONCLUSIONS.....	63
8.0	RECOMMENDATIONS	69
9.0	REFERENCES.....	72

APPENDIX

A	SUMMARY OF OPERATING PARAMETERS RECORDED DURING THE FIELD STUDY	79
---	--	----

LIST OF FIGURES

FIGURE	TITLE	PAGE
1.	Process flow diagram for the Envirex fluidized-bed bioreactor.....	7
2.	Enrichment of chlorobenzene-degrading bacteria from (A) activated sludge and (B) groundwater samples.....	20
3.	Kinetics of chlorobenzene degradation by (A) activated sludge and (B) groundwater enrichment cultures.....	21
4.	Reactor flow and organic loading rates.....	25
5.	Chlorobenzene concentrations in the (A) groundwater feed and (B) reactor influent (feed plus recycle).....	26
6.	Effluent chlorobenzene concentrations.....	27
7.	Comparison of oxygen (A) consumption and (B) influent total oxygen demand.....	29
8.	Relationship of oxygen applied vs. organic loading to the reactor.....	31
9.	Changes in carbon bed height during operation of the reactor.....	33
10.	Reactor influent and effluent pH.....	35
11.	Effects of shock loading on reactor performance.....	37
12.	Reactor temperature.....	43

FIGURE	TITLE	PAGE
13.	Process flow diagram for simulation of liquid-phase activated carbon adsorption.....	47
14.	Process flow diagram for simulation of air stripping with vapor-phase carbon adsorption.....	48
15.	Process flow diagram for simulation of air stripping with thermal oxidation.....	50
16.	Process flow diagram for simulation of the GAC fluid-bed bioreactor.....	52

LIST OF TABLES

TABLE	TITLE	PAGE
1.	Groundwater characteristics.....	18
2.	Summary of bioreactor performance data; effects of variation in organic loading (Day 0 to 113).....	24
3.	Summary of bioreactor performance data; operation at excess loading (Day 92 to 214).....	39
4.	Economic analysis of liquid-phase carbon adsorption.....	58
5.	Economic analysis of air stripping with vapor-phase carbon adsorption.....	59
6.	Economic analysis of air stripping with thermal oxidation.....	60
7.	Economic analysis of GAC-fluid bed bioreactor.....	61

(The reverse of this page is blank)

1.0 INTRODUCTION

1.1 Objectives

The present study involved a collaborative effort between research personnel at the Armstrong Laboratory, Environics Directorate, Tyndall Air Force Base and The Dow Chemical Company to develop additional data on the performance of bioreactors for treatment of groundwater contaminated with chlorinated aromatic compounds. The field work was performed at a Dow manufacturing site. Objectives of the study were as follows:

1. Evaluate potential sources of chlorobenzene-degrading bacteria from samples collected at the site to determine whether specialized strains or indigenous bacteria would be required as inoculum during startup of the bioreactor.
2. Evaluate the utility of an Envirex GAC fluid-bed bioreactor system to treat chlorobenzene-contaminated groundwater.
3. Evaluate performance over a range of operating conditions, i.e.,
 - a. Measure the effects of organic loading on effluent quality
 - b. Define oxygen uptake and utilization rates
 - c. Determine off-gas rates and quality
 - d. Determine effluent biomass concentrations.
4. Compare costs of groundwater treatment using the GAC fluid-bed bioreactor with other conventional groundwater treatment technologies, e.g. air-stripping, carbon adsorption, etc.

1.2 Background

Current practices to remediate contaminated groundwater beneath industrial sites frequently involve groundwater recovery and treatment. Installation of "pump-and-treat" systems has proven effective for achieving hydraulic containment of subsurface

contamination, thereby eliminating off-site migration. Technologies frequently used for groundwater treatment include phase separation, air- or steam-stripping and carbon adsorption. To avoid venting volatile organic compounds directly to the atmosphere, contaminants removed by air-stripping may be recovered on activated carbon or destroyed by thermal oxidation. Although biological processes have been used for many years for wastewater treatment, the application of biotechnology to groundwater treatment has often been limited by low concentrations of organic compounds, low microbial growth rates, and the inability to retain sufficient levels of active biomass in the reactors. However, recent advances in the understanding of biofilm processes (1-3), coupled with the development of fixed-film bioreactors have facilitated the application of biological processes to groundwater treatment (4-8).

Working in conjunction with Envirex Inc., Hickey and coworkers (7) have recently developed a granular activated carbon (GAC) fluidized-bed bioreactor for treatment of contaminated groundwater. The technology offers several advantages over other commercially available bioreactors:

- a) because pure oxygen is predissolved with the influent water, the bioreactor can be used to treat volatile organic compounds since volatilization from the reactor is essentially eliminated,
- b) low strength wastes can be treated effectively because of the ability to maintain high biomass concentrations,
- c) high removal efficiencies (low ppb effluents) can be achieved at short hydraulic residence times, and
- d) fluidized-bed reactors are less prone to fouling or plugging as compared to packed-bed systems.

Skid-mounted Envirex GAC fluid-bed bioreactors are commercially available and have been widely used for treatment of groundwater and process water containing readily biodegradable aromatic hydrocarbons, such as mixtures of benzene, toluene, ethylbenzene and xylene ([BTEX];9-12). Economic evaluation suggests that

biological treatment of BTEX-contaminated groundwater is cost-effective when compared with other conventional technologies such as air-stripping or carbon adsorption (12).

In contrast, substantial quantities of groundwater are contaminated with chlorinated organic compounds that have proven resistant to biodegradation. Extension of biological treatment technologies to such compounds will require that specialized microbial processes be discovered and refined. For example, until recently chlorinated benzenes were considered relatively resistant to biodegradation. Initial attempts to isolate bacteria capable of utilizing chlorobenzenes as sole carbon and energy sources frequently required extensive acclimation periods ranging from 6-12 months (13-15). Over the past few years, Spain and co-workers have reported isolation and characterization of several Pseudomonas species capable of growth on a variety of mono-, di- and trichlorobenzenes (16-19). One isolate, designated as strain JS150, was shown to have unique ability to biodegrade a broad spectrum of chlorinated aromatic solvents alone or in combination with non-chlorinated homologs (19).

Extensive research on strain JS150 to determine the biochemical pathways and reaction mechanisms allowed for development of a pilot-scale bioreactor that proved highly effective in field trials (20). During a 3-week demonstration conducted at Kelly Air Force Base, Texas, upflow fixed-film bioreactors were tested on groundwater containing a mixture of aromatic and chloroaromatic hydrocarbons. The reactors were capable of reducing the concentration of the groundwater contaminants from parts per million levels down to low parts per billion levels when operated at a hydraulic residence time of 40 minutes.

Microbiological analysis of the reactor during the field trial indicated that strain JS150 was eventually displaced by indigenous microorganisms present in the groundwater (21). This observation questions the need for specialized bacterial strains to be used as

inoculum during startup of bioreactors for treatment of chlorinated organic compounds. To address this issue, Nishino et al (21) have recently studied the distribution of chlorobenzene bacteria at contaminated sites. Chlorobenzene-degrading bacteria were readily isolated from contaminated wells, whereas attempts to isolate competent bacteria from noncontaminated wells were unsuccessful. These results suggest that indigenous bacteria from contaminated sites could be used to seed bioreactors during startup, if sufficient cell densities are available. For example, activated sludge obtained from the site has been frequently used as the inoculum source for startup of GAC fluid-bed bioreactors (22). However, the use of specialized bacterial strains may be necessary in situations involving recent releases of chlorinated organics, or when the water to be treated is essentially sterile (e.g. process wastes).

On the basis of the field trial, Pettigrew et al (20) recommended that biological treatment be considered for remediation of chlorobenzene-contaminated groundwater at Kelly Air Force Base. Additional field studies were recommended to compare fixed-film bioreactors with other conventional groundwater treatment technologies. Such efforts should examine reactor performance over a range of operating conditions (loading, residence time, etc), as well as determine treatment costs.

2.0 ENVIREX BIOREACTOR DESIGN AND OPERATION

2.1 Process Fundamentals

The fluidized-bed bioreactor is an attached-growth biological system in which the microorganisms used to treat the water are grown on a solid-support media, such as granular activated carbon (GAC). Because the microbes are retained in the system, the capacity of the reactor is a function of the amount of surface area available for growth. With fixed- or packed-bed systems, as growth occurs the system may eventually plug as the support media becomes packed with biomass. The fluidized-bed process overcomes this problem by providing a large surface area on the carbon support media. Bacterial growth develops on the external surface of the carbon and throughout the internal macropores. The carbon particles are fluidized in the reactor column by an upflow of water from the base, which is evenly distributed throughout the bed. Complete particle-to-particle separation maximizes the surface area available for growth. The thickness of the biofilm is mechanically controlled, thereby eliminating the potential plugging of the bed with biomass. The biofilm surface area provided by this technique is very large, and can easily exceed 10-times the amount on typical fixed packings (12).

As microbial growth occurs on individual carbon particles, the diameter of each particle increases, adding to the total height of the bed. In addition, as the film grows in thickness the density of the carbon particles decreases. This also results in expansion of the bed. To prevent overexpansion and eventual loss from the system, microbial growth must be controlled by wasting. With the Envirex system, a mechanical device intercepts the bed at the desired height to shear the biomass from the carbon. Excess cell material leaves the system with the effluent water, and the smaller carbon particles settle back to the base of the reactor.

2.2 System Components and Function

Components of the Envirex model 30 skid-mounted bioreactor include two fluidization pumps (one operating, one standby), an oxygen generation system, bubble contactor, nutrient feed system, pH control system, fluid-bed reactor and a biomass control system (23). A simplified flow diagram of the system is shown on Figure 1.

Influent water is initially passed through a duplex basket strainer and combined with the recycle flow to give a total flow to the reactor of approximately 27 to 30 gpm. The influent feed flow rate is controlled using a diaphragm valve and is measured with a magnetic flow meter. The combined stream enters the suction side of the fluidization pump, and the flow rate is controlled on the discharge side using a diaphragm valve. The fluidization flow rate is also measured with a magnetic flow meter, and both flows are displayed on the main electrical panel. Since the system is designed with an internal recycle system, the carbon bed is continuously fluidized at the design fluidization flow rate (30 gpm), which is independent of the influent feed flow rate. Should the influent feed completely shut down, the system will continue to operate on 100% recycle. Conversely, if the influent flow equals the fluidization flow, water passes through the system once with a hydraulic residence time of about 7 minutes. Influent flow is determined by the maximum loading rate to the reactor, which is based on the organic loading and the effluent requirements.

Oxygen is then injected in-line and the water flows through an eductor where the hydraulic pressure differential enhances oxygen dissolution. The oxygen gas stream is continuously generated and stored in a tank on the skid using a batch-type, pressure-swing-adsorption (PSA) system, which is supplied with dry, pressurized air from a compressor. The purity of the gas is typically 90-95% oxygen, with the remainder consisting of nitrogen and argon (23).

Figure 1. Process flow diagram for the Envirex fluidized-bed bioreactor.

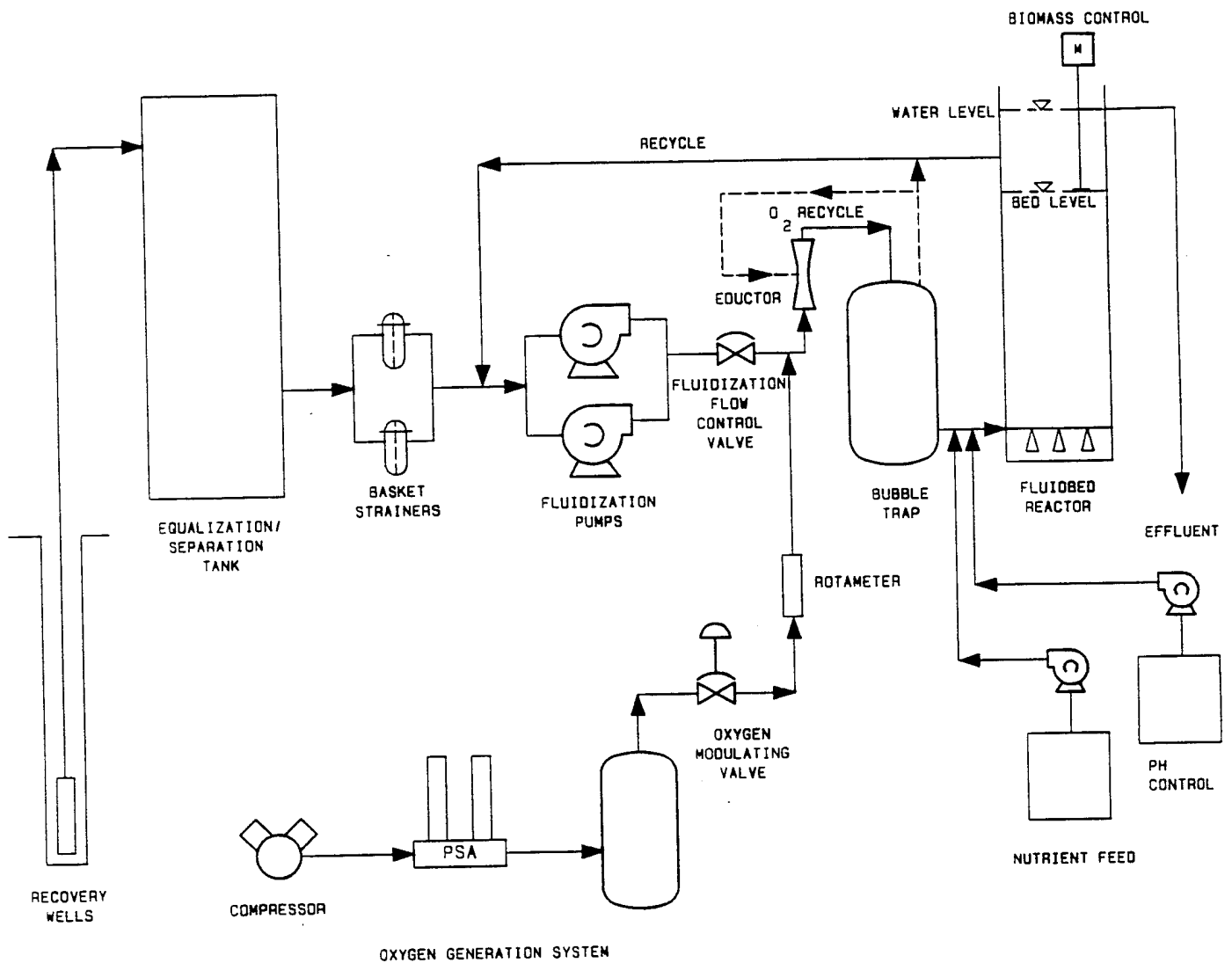

FLUIDIZED BED
PROCESS FLOW DIAGRAM

As the water enters the bubble trap, a decrease in the hydraulic velocity separates any undissolved gas (oxygen, nitrogen, argon) which are reintroduced at the eductor. Continuous monitoring allows for very close control of the bubble trap to maintain a minimum gas volume. When a bubble is created, a level control device in the tank opens a valve which purges the small quantity of gas to the atmosphere via the recycle line. Because this stream is untreated, a small carbon canister may be placed in the headspace above the recycle line to capture any potential volatile emissions. However, since the amount of untreated gas is very small, an exemption from air permit regulations may be negotiated. As the water exits the bubble trap, the dissolved oxygen (DO) concentration of the reactor influent is measured with an in-line DO probe, and is continuously displayed on the main electrical panel.

Inorganic nutrients (e.g., nitrogen, phosphorus) are fed into the system prior to the reactor by an electronic metering pump. The nutrient solution contains a mixture of urea and dibasic ammonium phosphate, which are added to the system based on the total oxygen demand (TOD) to satisfy a TOD:N:P ratio of 100:5:1 (24).

A pH control system is an optional feature present on some Envirex units. Electrodes mounted in-line and in the top of the reactor allow for continuous monitoring of influent and effluent pH levels. The pH of the reactor effluent is controlled to a set point programmed in the pH analyzer/controller on the main electric panel. Caustic (or acid) solution required to control the reactor pH is added to the system prior to the reactor inlet using an electronic metering pump.

All skid-mounted Envirex fluidized-bed bioreactors are equipped with a reactor column with a total height of 15 feet. To increase the bed volume, the diameter of the column is increased. The influent enters the base of the reactor through a series of distribution nozzles to achieve uniform fluidization of the carbon bed. As the organic constituents in the water flow through the carbon bed, biological respiration utilizes dissolved oxygen for

growth, yielding carbon dioxide, water and cell mass. The amount of oxygen required by the system is a function of the concentration of organic compounds entering the reactor. Dissolved oxygen measured in the effluent serves as the primary control parameter and is displayed on the main electrical panel. To insure adequate levels of dissolved oxygen are supplied to the reactor, a microprocessor controller maintains a residual dissolved oxygen level of 2 mg/L in the effluent. If the biological oxygen demand increases in response to a change in organic carbon concentration, the effluent dissolved oxygen level would be temporarily reduced, signaling for more oxygen to be delivered to the influent.

As microbial growth occurs in the reactor, the density of the carbon particles decreases, resulting in expansion of the bed. To prevent overexpansion and potential loss of carbon from the system, a growth-control mixer is installed in the top of the reactor to intercept the bed at the 11-foot level. Excess biomass sheared from the carbon leaves the system with the effluent water, and the carbon particles settle back to the base of the reactor.

3.0 MATERIALS AND METHODS

3.1 Chemicals

Chlorobenzene (HPLC grade; 99.9%) was obtained from the Aldrich Chemical Company, Milwaukee, WI. All other chemicals were of reagent grade or better and were from commercial sources.

3.2 Microbial Enrichment

Microorganisms were enriched from samples of activated sludge and contaminated groundwater collected at the study site. The samples were chilled on ice and shipped to the laboratory by overnight express carrier.

Portions (10-50 mL) of the sludge or groundwater were transferred to 2-liter flasks containing 500 mL of mineral salts medium (pH 7.1; [25]). Chlorobenzene was supplied to the cultures as the sole carbon source using vapor bulbs as previously described (26). The flasks were incubated on a rotary shaker at 200 rpm at ambient temperature (ca. 27°C). Samples were periodically removed from the cultures and analyzed for an increase in chloride concentration as described below. Microbial growth was also monitored by changes in optical density at 600 nm using a Bausch and Lomb Spectronic 20 spectrophotometer. The enrichment cultures were periodically transferred to fresh medium to eliminate non-chlorobenzene-degrading organisms. Individual isolates were obtained by plating on mineral salts agar and incubation in a desiccator with chlorobenzene vapors at 25°C.

The utilization of chlorobenzene by the enrichment cultures was quantitatively measured by gas chromatographic analysis. Cells grown in mineral salts medium with chlorobenzene as the sole carbon source were harvested by centrifugation (6000 rpm, 30 min), and the cell pellet was resuspended in fresh medium. Portions (1 mL) of this suspension were placed into serum bottles (160 mL)

containing 50 mL of mineral salts broth. To ensure maintenance of aerobic conditions, the bottles were purged with oxygen gas for 5 min. The cultures were then amended with varying concentrations of chlorobenzene (20 to 100 ppm; neat) and immediately sealed with Teflon[®]-faced silicon rubber septa and aluminum crimp caps. Uninoculated control bottles were also prepared to characterize any abiotic losses. The serum bottles were incubated on a rotary shaker at 200 rpm at 25°C. Portions of the cultures were periodically removed and analyzed for chlorobenzene and chloride concentrations as described below.

3.3 Bioreactor Design and Operation

The Envirex model 30 fluidized-bed bioreactor used for the field study included a skid-mounted column reactor and the supporting equipment. The reactor column was 15 feet tall and 20 inches in diameter, and had a working volume of 210 gallons. The reactor was designed for a total fluidization flow (forward feed plus recycle) of 25 to 30 gpm to allow for 50% expansion of the bed. Hydraulic residence time within the reactor was in the range of 7 to 8 minutes.

The bioreactor was installed parallel to an existing groundwater treatment system. During startup, the reactor was loaded with 350 pounds of Calgon type MRX-P 10 x 30 granular activated carbon (Calgon Carbon Corp., Pittsburg, PA). The unexpanded height of the carbon bed was 7 feet. The system was inoculated with 30 gallons of activated sludge obtained from the site wastewater treatment plant. The system was operated and maintained according to the operating discipline provided by the manufacturer (23).

Organic loading capacity of the unit was a function of the oxygen transfer capacity of the system. For the current design, the stated capacity is in the range of 250 to a maximum of 400 pounds of total oxygen demand (lb TOD) per 1000 cubic feet per day (23). Based on a working reactor volume of approximately 25 ft³, the equivalent

loading capacity for the model 30 ranges from 6 to 10 lb TOD per day. During the study, organic loading to the reactor was varied by adjusting the groundwater flow rate. Chlorobenzene loading was calculated using the equation:

$$\text{LOAD (lb/day)} = \text{FLOW (gpm)} * \text{CONC (ppm)} * 0.012$$

Note that the product of the groundwater flow rate and concentration are multiplied by a conversion factor of 0.012 to calculate the chlorobenzene loading in terms of pounds per day. Based on the stoichiometry, the TOD loading can then be calculated by multiplying the chlorobenzene loading by a factor of 2.

Influent and effluent dissolved oxygen concentrations were continuously monitored using a Great Lakes Instruments model 697D/5340D dissolved oxygen analyzer system. The influent dissolved oxygen sensor was located in-line prior to the reactor, while the effluent probe was located in the top of the reactor. The sensor probes were cleaned at least biweekly, depending on level of biomass fouling. The analyzers were calibrated monthly by comparison of the measured dissolved oxygen content of a water sample with another independently calibrated instrument (e.g., YSI model 58 dissolved oxygen meter). Dissolved oxygen concentrations in the reactor were controlled by the effluent probe and a Powers model 535 process controller to maintain 2.5 ppm of oxygen in the reactor outlet.

Comparison of the stoichiometry between oxygen consumption in the reactor and the total oxygen demand of the influent stream provided an indication of bioreactor performance. Oxygen consumption was routinely calculated from the difference between the influent and effluent dissolved oxygen concentrations. However, oxygen utilization was also estimated from the oxygen gas flow rate. Empirical observations by the manufacturer suggest that the oxygen consumption (in ppm) can be approximated by multiplying the gas flow rate by a factor of 10 (27). During the field study, values

calculated by the 2 methods were in general agreement (data not shown). The mass of oxygen supplied to the reactor was calculated using the equation:

$$\text{O}_2 \text{ (lb/day)} = \text{TOTAL REACTOR FLOW (gpm)} * \text{O}_2 \text{ CONSUMED (ppm)} * 0.012$$

An inorganic nutrient solution was continuously supplied to the reactor based on the organic loading to satisfy a TOD:N:P ratio of 100:5:1 (24). The solution was prepared by dissolving 9 pounds of Biotreatment Nutrient Mixture #36 (Milport Chemical Company, Milwaukee, WI) in 25 gallons of water. The mixture consisted of urea and diammonium phosphate (2:1). The flow rate of the nutrient pump was adjusted based on the organic loading according to vendor specifications. Samples of the effluent were collected weekly and analyzed for ammonium and phosphate levels as described below.

The influent and effluent pH levels were continuously monitored using Great Lakes Instruments model 672P pH analyzers and liquid crystal polymer-encapsulated sensors. The probes were calibrated weekly using a 2-point method (pH 7 and pH 4) as described by the manufacturer. The effluent controller was initially set to maintain the reactor pH in the range of pH 7.2 to 7.7. However, to avoid scaling due to calcium carbonate precipitation, the control set points were changed early in the study to maintain the reactor in the range of pH 6.6 and 6.8.

A variety of operating parameters were monitored throughout 214 days of the field study. Instruments on the control panel monitored the groundwater, recycle and oxygen flow rates, reactor influent and effluent pH, dissolved oxygen levels, and temperatures. Water level in the bubble trap was monitored using a sight glass mounted on the outside of the tank. The carbon bed height was measured by lowering a small bucket sampler into the reactor and collecting samples at various known depths. A 1-pound weight was used to periodically conduct bed soundings to detect clumping of the carbon particles. Chlorobenzene concentrations were monitored by taking

grab samples from sample ports located on the groundwater (forward feed) and reactor influent (feed + recycle) lines. Effluent chlorobenzene concentrations were measured in grab samples collected directly from the top of the reactor. The samples were collected in 40 mL vials containing 0.2 mL of dilute H₂SO₄ (1:1) as a stabilizer, and sealed with Teflon[®]-faced silicon rubber septa and screw caps. Effluent samples were also collected on a weekly basis for analysis of ammonia nitrogen, orthophosphate, total suspended solids and volatile suspended solids.

3.4 Analytical Methods

Bioreactor samples were analyzed by gas chromatography either at the study site or the laboratory in Midland, MI. Preliminary studies indicated that acidified samples were stable for 2 weeks when maintained at 4°C.

Aqueous samples (unfiltered) were routinely analyzed by direct injection using either a Varian model 3700 or a Hewlett-Packard model 5730A gas chromatograph equipped with a flame ionization detector. Separations were achieved with a column (120 cm x 3 mm i.d.) packed with Tenax[®] GC (60/80 or 80/100 mesh; Alltech Associates, Inc., Deerfield, IL) with a nitrogen carrier at a flow rate of 30 mL/min. The oven temperature was 190°C. Detector outputs were connected either to a PE Nelson Access Chrom GC/LC computer data system or a Hewlett-Packard model 3380 recording integrator. Chlorobenzene concentrations were calculated from peak area measurements by comparison with an external standard prepared in water. The detector response was linear over the concentration range of interest (0-200 ppm), with a detection limit of approximately 0.5 ppm.

To quantitate low levels of chlorobenzene, aqueous samples were also analyzed using a Hewlett-Packard model 19395A automated head-space sampler coupled to a model 5890A gas chromatograph equipped with a flame ionization detector. The head-space sampler

was operated at the following conditions: sample temperature, 60°C; equilibration time, 240 min; valve/loop temperature, 65°C; pressurization time, 5 sec; injection loop fill time, 10 sec; and injection time, 36 sec. Head space samples were injected using a split ratio of 2:1 at an injector temperature of 200°C with a continuous septum purge of 5 mL/min. Chromatography was performed using a GSQ megabore capillary column (30 m x 0.53 mm i.d.; J&W Scientific, Folsom, CA). Compounds were eluted using a nitrogen carrier at a flow rate of 25 mL/min at a head pressure of 10 psi. The oven temperature was programmed to increase from 170°C to 215°C at a rate of 4 C/min. Output of the flame ionization detector was connected to a PE Nelson computer data system as above. The detector response was linear over the concentration range of interest (10 to 500 ppb) with a quantitation limit of 10 ppb.

Volatile emissions from the bioreactor column were periodically monitored using a TLV Bacharach organic vapor analyzer (28). The instrument was calibrated before use with a methane/air mixture.

Aqueous samples were analyzed for a variety of conventional parameters, including chloride, ammonia, phosphate and total and volatile suspended solids. Chloride and ammonium ion concentrations were analyzed using Orion model 94-17 or model 95-12 ion selective electrodes, respectively, as described by the manufacturer (29). Ortho-phosphate was determined by the ascorbic acid method according to U.S. Environmental Protection Agency (EPA) method 365.2 (30). Total and volatile suspended solids were determined by gravimetric analysis (31). Additional groundwater samples were submitted to A&L Midwest Laboratories, Omaha, NE for inorganic analysis.

4.0 SITE DESCRIPTION

4.1 Current Site Remediation

The field test was conducted at an existing Dow manufacturing facility, where the groundwater has been previously shown to contain chlorobenzene, along with small amounts of aniline. Chlorobenzene concentrations are typically in the range of 100 to 170 ppm, while aniline levels are generally less than 5 ppm. To hydraulically control off-site migration, current remedial activities consist of groundwater recovery and treatment. Contaminated groundwater is recovered with a series of 25 wells and collected in a storage tank before treatment.

Volatile organic contaminants are removed from the groundwater using a packed-tower air stripper that is associated with manufacturing operations at the site. Average groundwater and air flow rates to the stripper are 30 gpm and 300 scfm, respectively. Since the water receives additional biological treatment, chlorobenzene concentrations in the effluent are controlled to below a detection limit of 1 ppm. The overheads from the stripper are treated by thermal oxidation.

During the field study, the Envirex fluidized-bed reactor was installed parallel to the existing system, which afforded the opportunity for comparison with conventional air-stripping technology. Based on the chlorobenzene concentration of the groundwater, the organic loading capacity for the bioreactor would be achieved at a flow rate of approximately 3.5 gpm. As a result, the higher levels afforded the ability to examine performance of the bioreactor over a wide range of influent loadings. Changes in organic loading to the system were accomplished by increasing the groundwater flow rate.

4.2 Groundwater Characterization

Before the study, a composite sample from the storage tank was submitted for analysis. Typical values for a number of conventional parameters are summarized in Table 1.

The groundwater was slightly alkaline (pH 7.7) with total dissolved solids concentration of 2022 ppm. The predominant cations were sodium, calcium and magnesium, while chloride and bicarbonate were the principle anions detected. Only trace amounts of inorganic nutrients such as nitrate and orthophosphate were present in the sample. The dissolved iron concentration of the groundwater was below the detection limit (<0.05 ppm).

Table 1. Groundwater characteristics.

Parameter	
pH	7.7
Conductivity (mmhos/cm)	3.1
Total dissolved solids (ppm)	2022
Sodium (ppm)	313
Potassium (ppm)	2
Calcium (ppm)	220
Magnesium (ppm)	52
Phosphate (ppm)	0.5
Nitrate (ppm)	0.4
Bicarbonate (ppm)	369
Sulfate (ppm)	29
Chloride (ppm)	846
Iron (ppm)	< 0.05
Manganese (ppm)	1.6
Copper (ppm)	< 0.01
Zinc (ppm)	0.03

5.0 RESULTS

5.1 Evaluation of Inoculum Sources

To determine if sources of chlorobenzene-degrading bacteria were readily available at the site, flasks containing mineral salts medium were inoculated with activated sludge or groundwater, and incubated with chlorobenzene as the sole carbon source. After 4 days, chlorobenzene degradation was indicated in the cultures by an increase in chloride concentration of the medium. Portions of the cultures were periodically subcultured to fresh media, and changes in chloride level and optical density were recorded as shown in Figure 2. Rates of chlorobenzene degradation (expressed as chloride released) were relatively constant in the cultures for each of three successive transfers. Degradation rates in activated sludge subcultures ranged from 11 to 14.1 mg chloride released per liter per day, and were similar to rates between 10.8 and 12.9 mg Cl⁻/L-day observed in flasks containing the groundwater inoculum. The rates of microbial growth, as indicated by changes in optical density, were also similar in both activated sludge and groundwater cultures. Considerable wall growth was also evident in all cultures, suggesting a preference for microbial attachment to surfaces.

Cells from each of the third subcultures were harvested and used as inoculum for batch kinetic tests. Serum bottles containing mineral salts medium were amended with varying chlorobenzene concentrations (20 to 100 ppm), and inoculated with either activated sludge or groundwater isolates. Initial cell densities in the batch tests, as measured by plate counts on mineral salts-chlorobenzene agar, were in the range of 6-9 x 10⁶ cells/mL. Chlorobenzene was readily degraded in all cultures with the stoichiometric release of chloride (data not shown). The initial rates of chlorobenzene removal were similar in all cultures, as shown in Figure 3. Degradation rates ranged from 3.5 to 6.7 mg/L-hour, suggesting that the kinetics of biodegradation are zero-order at concentrations above 20 mg/L. Chlorobenzene removal from the

Figure 2. Enrichment of chlorobenzene degrading bacteria from (A) activated sludge and (B) groundwater samples. Changes in optical density (—) and chloride concentration (---) in the first, second and third subcultures.

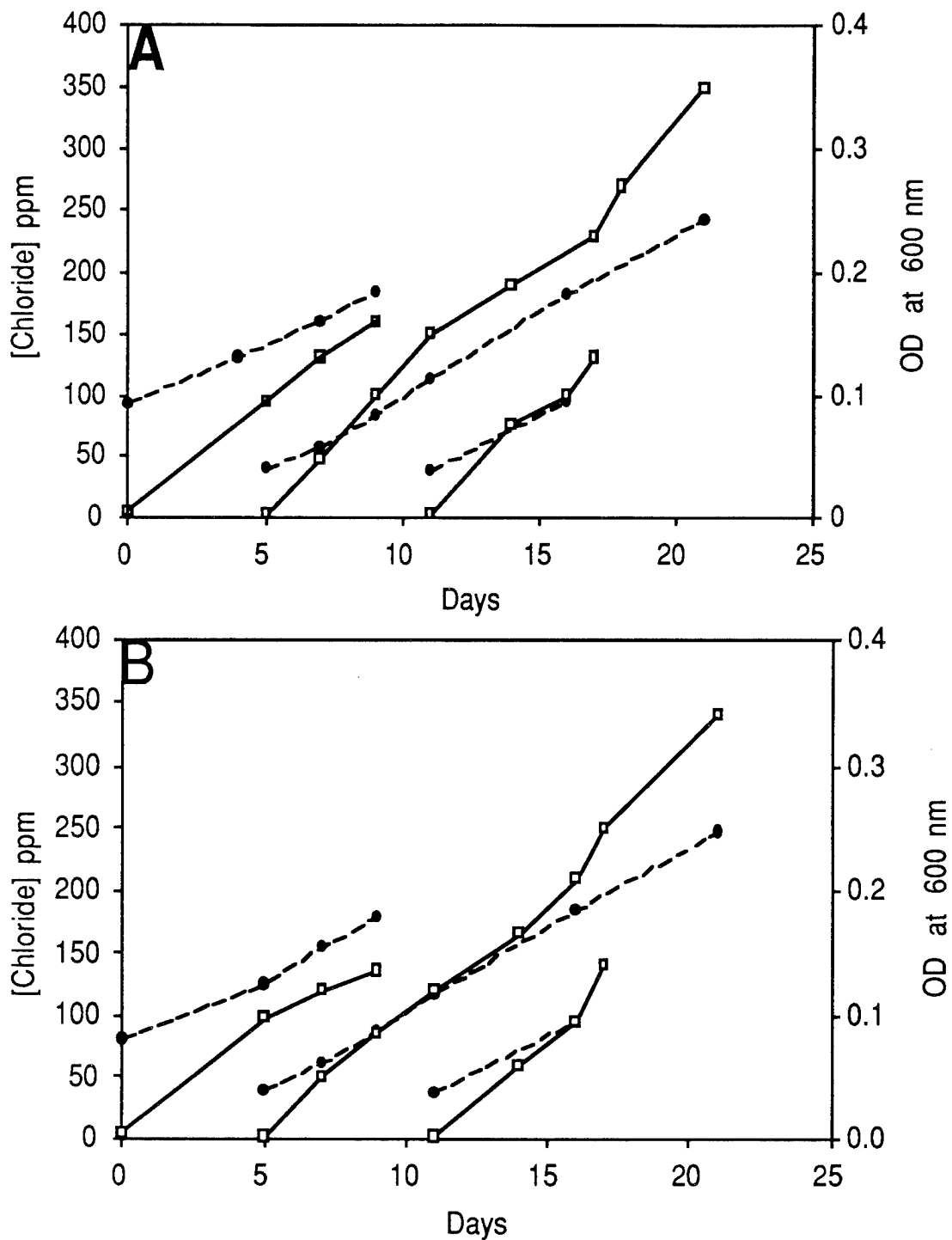
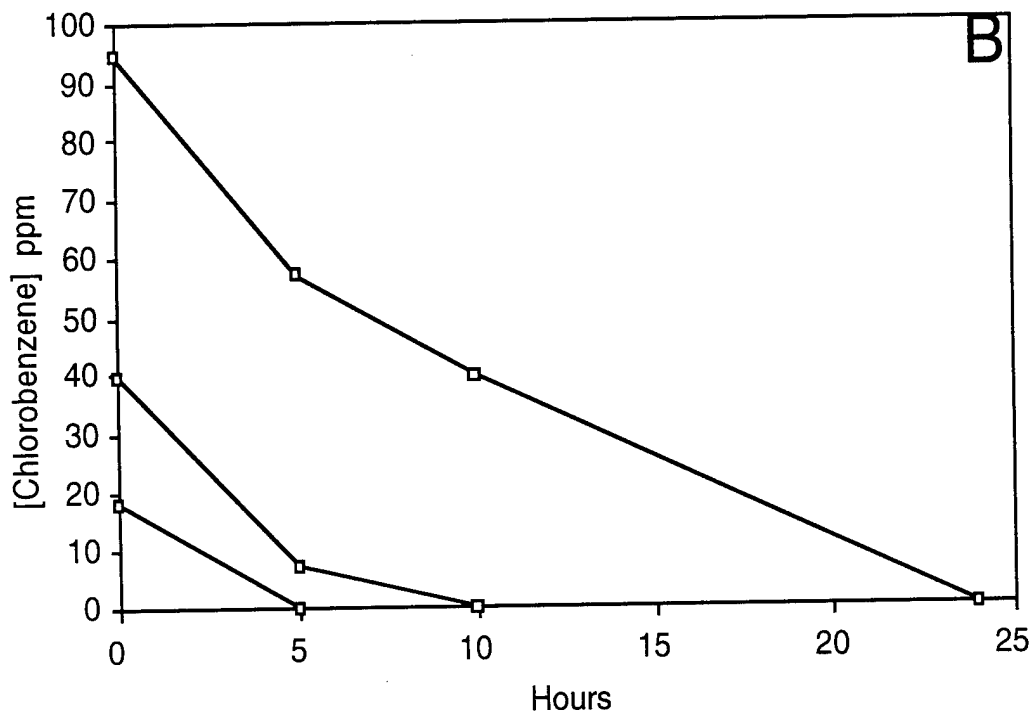
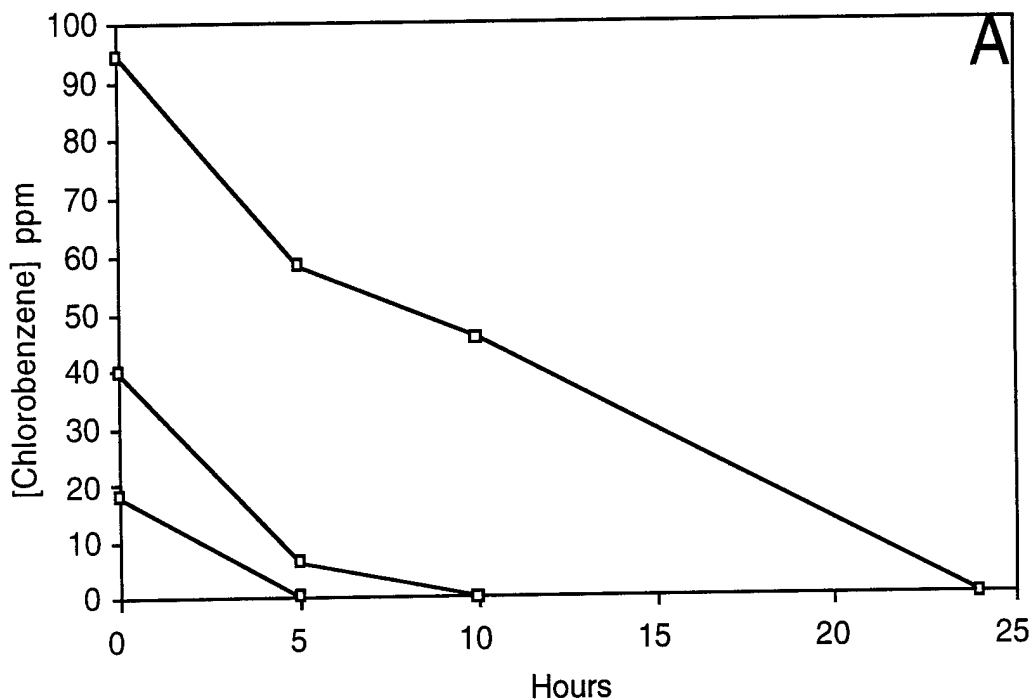

Figure 3. Kinetics of chlorobenzene degradation by (A) activated sludge and (B) groundwater enrichment cultures. Chlorobenzene losses from non-inoculated controls were negligible (data not shown).



bottles was due to biodegradation, since negligible losses were observed in non-inoculated controls (data not shown).

Mineral salts agar plates inoculated from the enrichment cultures were incubated with chlorobenzene as the sole carbon source. After 1 week, white, cream or yellow colonies were observed. Based on colony morphology alone, at least 6 distinct types of chlorobenzene-degrading bacteria were present in cultures enriched from activated sludge, while 2 distinct types were isolated from the groundwater. These results suggested that a specialized inoculum would not be required during startup of the bioreactor, but that activated sludge from the site could be employed. Because of the presence of chlorobenzene-degrading bacteria in the groundwater, it was anticipated that the activated sludge inoculum would eventually be displaced by the indigenous groundwater bacteria.

5.2 Bioreactor Performance Evaluation

5.2.1 Startup

Once the reactor was installed and hydraulically tested, 350 pounds of granular activated carbon were loaded into the reactor. Groundwater and fluidization flow rates were adjusted to 2 and 27 gpm, respectively, to preload the carbon with chlorobenzene. Automatic control of the oxygen delivery system maintained 2.5 ppm of dissolved oxygen in the effluent. After 2 days, the reactor was inoculated by the addition of 30 gallons of activated sludge obtained from the site wastewater treatment plant. The flow of groundwater to the reactor was temporarily stopped, nutrient addition was initiated, and the reactor was operated on internal recycle for 2 days. By Day 4, evidence of biological activity in the reactor was indicated by a difference between the influent and effluent dissolved oxygen concentrations.

5.2.2 Operation

Following startup, the bioreactor was operated for a total of 214 days. Parameters including groundwater, recycle and oxygen flows, influent and effluent dissolved oxygen concentrations, pH and temperatures, were measured daily according to the prescribed operating discipline. Key operating parameters recorded during the study are summarized in Appendix A.

5.3 Organic Loading and Treatment Efficiency

To examine the performance of the bioreactor over a range of operating conditions, the organic loading to the system was periodically increased by adjusting the groundwater flow rate. Performance data, divided on the basis of flow and organic loading are summarized in Table 2.

During the first 92 days, the reactor was operated for 3- to 7-week intervals at average groundwater flow rates of 1.6, 2.8 and 4.0 gpm, corresponding to organic loadings of approximately 5.0, 8.5 and 12.1 lb TOD per day, respectively (Figure 4). Although the groundwater flow rates (feed) were relatively constant during each period, organic loading varied, due to changes in the groundwater composition. Since chlorobenzene concentrations in the groundwater ranged from 100 to 170 ppm (Figure 5A), levels in the reactor influent (feed diluted with recycle; Figure 5B) varied daily. Influent chlorobenzene concentrations for each of the three loadings were as follows:

- a) Days 0 to 21 = 7.0 ± 3.5 ppm (mean \pm standard deviation)
- b) Days 21 to 43 = 11.9 ± 1.7 ppm
- c) Days 43 to 92 = 17.8 ± 3.6 ppm

In spite of the variation in loading, performance of the bioreactor was essentially constant, and effluent chlorobenzene concentrations (Figure 6) were generally below the detection limits of the analytical methods employed (<0.5 and <0.01 ppm). The transient increase in the effluent chlorobenzene concentrations, beginning at

Table 2. Summary of bioreactor performance data; effects of variation in organic loading (Day 0 to 113).

Days	Flow (gpm)	Recycle Flow (gpm)	Bed Height (ft)	Temp (°C)	TOD Loading (lb/Day)	Feed Cl-ben (ppm)	Influent Cl-ben (ppm)	Effluent Cl-ben (ppb)	Influent TOD (ppm)	D.O. Consumed (ppm)	DO/TOD (p/p)	Treatment Efficiency (% of Feed)
0-21	1.6	28.1	7.5	31.1	5.0	135.4	7.0	ND	14.0	13.8	0.99	>99.5 or >99.99
21-43	2.8	26.8	7.9	28.8	8.5	124.5	11.9	ND	23.8	22.2	0.93	>99.5 or >99.99
43-92	4.0	28.2	10.6	26.8	12.1	127.1	17.8	ND	35.6	27.9	0.78	>99.5 or >99.99
92-113	5.0	29.6	9.9	25.4	17.2	144.5	26.3	1087.0	52.6	22.2	0.42	99.25

Figure 4. Reactor flow (\diamond) and organic loading rates (\square).

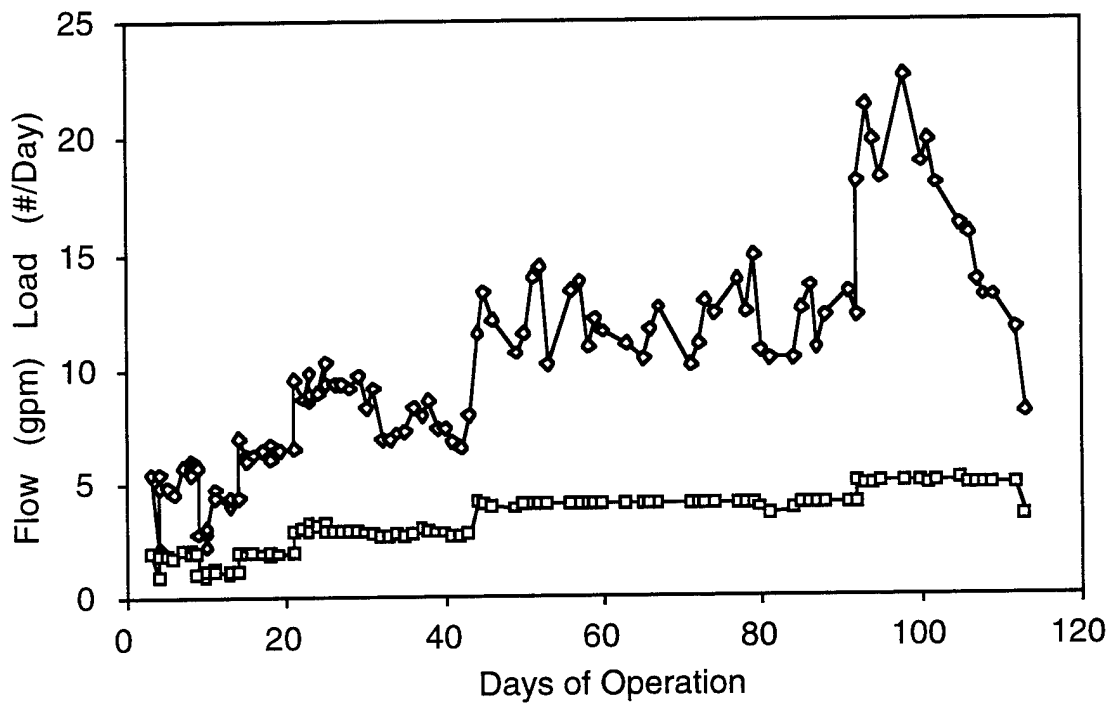

Figure 5. Chlorobenzene concentrations in the (A) groundwater feed and (B) reactor influent (feed plus recycle).

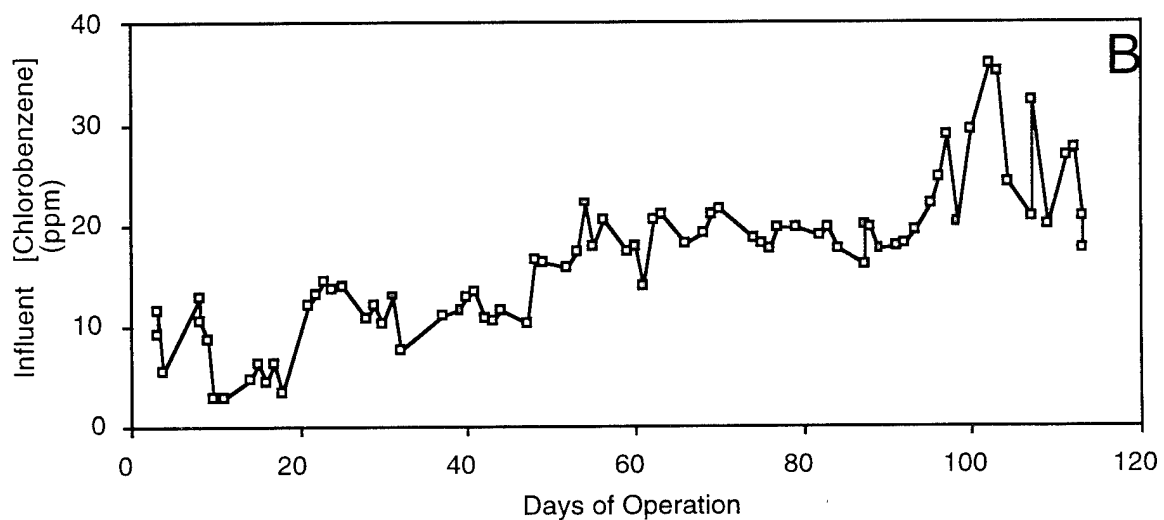
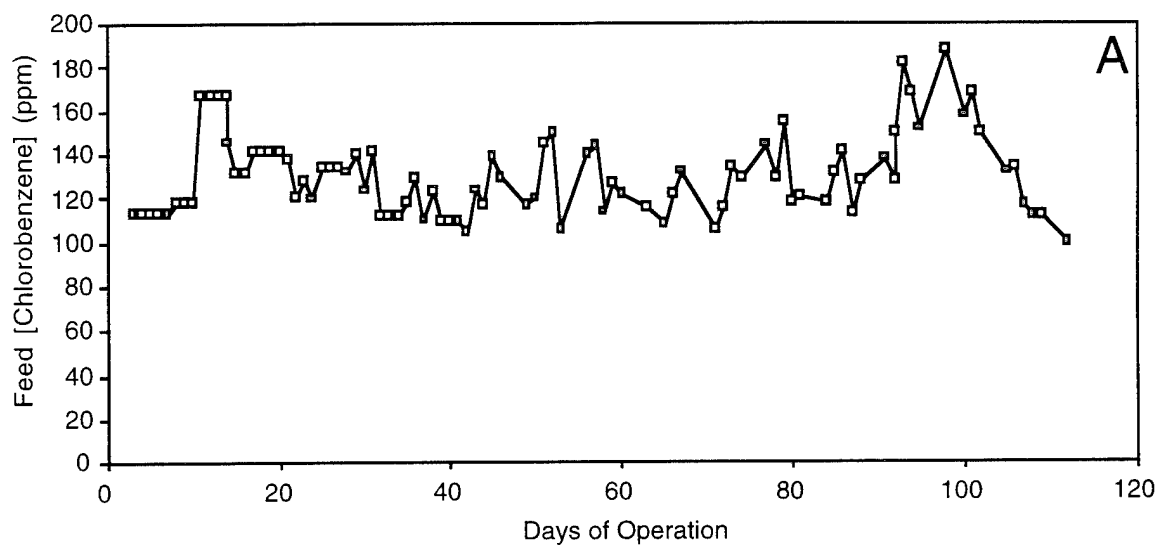
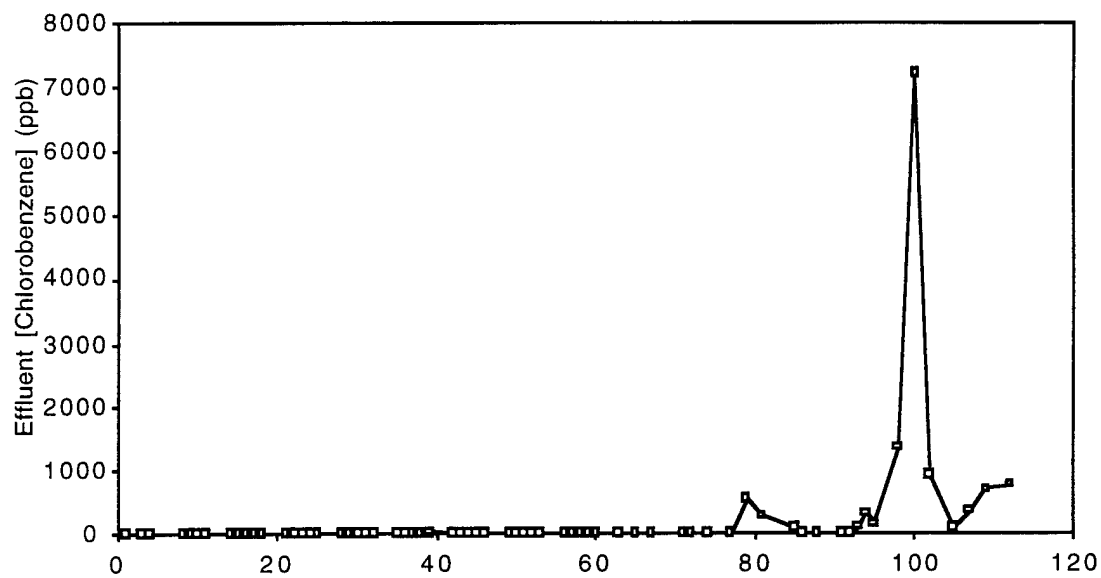

Figure 6. Effluent chlorobenzene concentrations.



Day 79, was apparently due to problems with the oxygen monitoring and delivery system. On the basis of the more sensitive analytical results, chlorobenzene treatment efficiencies during the initial 13-week period generally exceeded 99.99%.

On Day 92, the groundwater flow rate to the reactor was increased to an average of 5 gpm, thereby increasing the organic loading to about 17 lb TOD per day (Table 2). Performance during this period gradually declined, and effluent chlorobenzene concentrations ranged from nondetectable to as high as 7.2 ppm (Figure 6). Although the system was operated at an organic loading in excess of the design capacity (10 lb TOD/day), the average chlorobenzene removal efficiency exceeded 99% during this period. Extended operation at organic loadings in excess of the design capacity may have contributed to the eventual failure of the system. Performance data during this period (Days 113-155) are not included in the table, but are discussed in a subsequent section. While these data were useful for identifying critical operating parameters as well as potential improvements to the system, they were not representative of performance at loadings within the design capacity.

5.3.1 Oxygen consumption and stoichiometry

Comparison of the difference between influent and effluent dissolved oxygen (DO) concentrations and the total oxygen demand (TOD) of the influent stream was routinely used as an indication of bioreactor performance. As shown in Figure 7, when the reactor was operated near the design capacity (8.5 lb TOD/day; Days 21-43), oxygen consumption across the reactor generally agreed with the influent TOD. During this period, the average oxygen consumption and TOD values were 22.2 and 23.8 ppm, respectively (Table 2). The ratio of oxygen consumption to influent TOD ranged between 0.93 and 0.99 during the first 43 days of operation, suggesting that biodegradation was the principal removal mechanism.

Figure 7. Comparison of (A) oxygen consumption and (B) influent total oxygen demand.

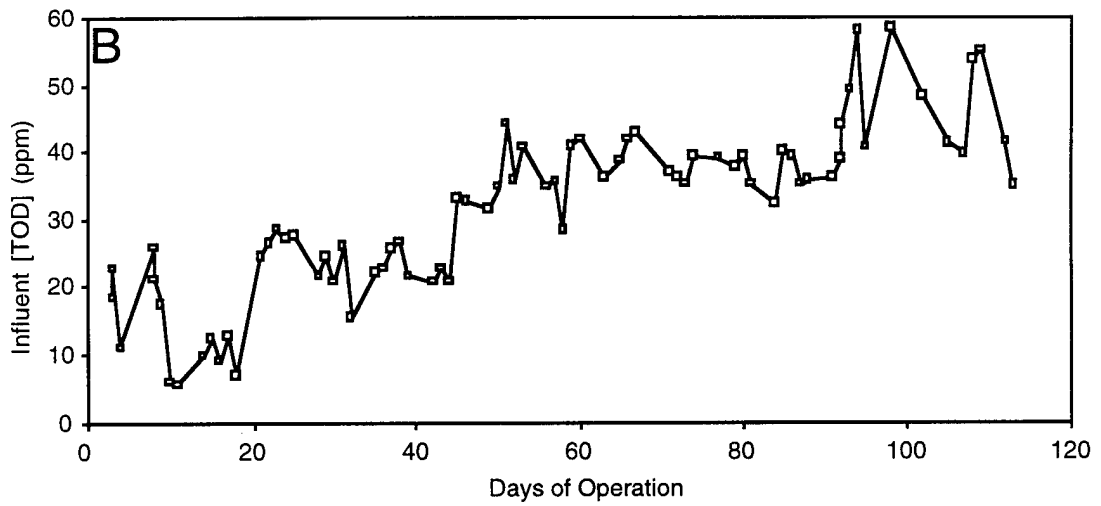
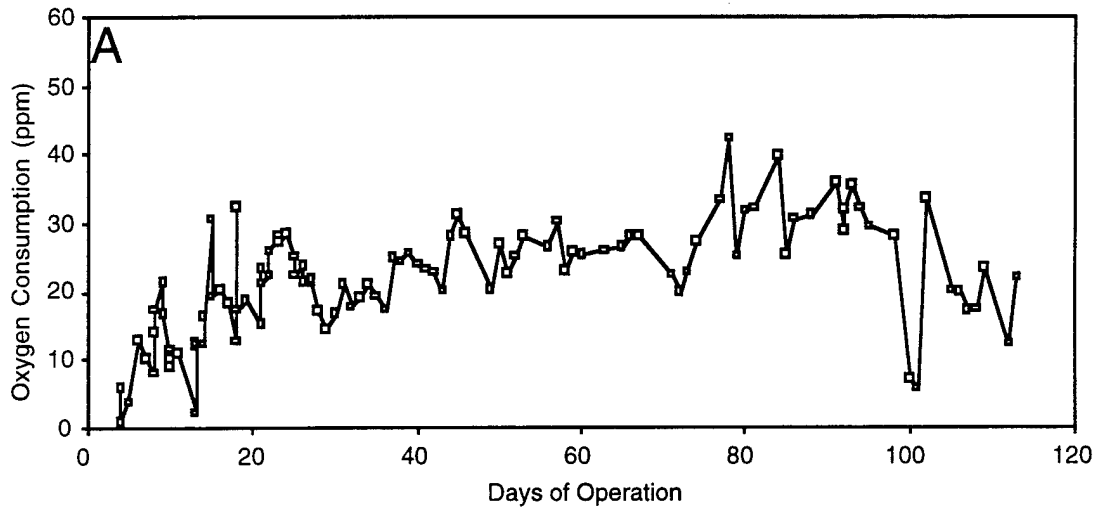

At loading rates in excess of 10 lb TOD/day, the ratio of oxygen consumption to the influent TOD concentration decreased, indicating the inability of the oxygen delivery system to satisfy the oxygen demand of the influent stream. From Days 43 to 92, the difference between dissolved oxygen levels across the reactor ranged from 19 to 42 ppm, while the influent TOD concentrations were between 28 and 44 ppm. The average DO/TOD ratio of 0.78 for this period was consistent with a reactor loading of 12 lb TOD/day. Although insufficient oxygen was available for biodegradation, chlorobenzene removal efficiencies exceeded 99.99%, suggesting that some treatment may have been due to adsorption of chlorobenzene onto the activated carbon media. From Days 92 to 113 the loading to the reactor was 17 lb TOD/day, and the DO/TOD ratio decreased to 0.42. While chlorobenzene biodegradation was substantially limited by the availability of dissolved oxygen during this period, the treatment efficiency remained as high as 99%.

The maximum organic loading capacity for the bioreactor is a function of the ability to deliver sufficient oxygen for biodegradation. Since the capacity to provide dissolved oxygen is controlled by the transfer efficiency of the eductor/bubble trap system and the recycle flow rate, oxygen concentrations in the reactor at excess loading can be used to define the actual operating capacity of the bioreactor. For Days 43 to 92, the organic loading of the reactor was 12 lb TOD per day, whereas the dissolved oxygen concentrations in the reactor ranged from 20 to 42 ppm (Figure 7). Based on an average dissolved oxygen concentration of 28 ppm and an average recycle flow rate of 28 gpm, the mass of oxygen delivered to the reactor was about 9.5 lb/day. Figure 8 compares the mass of oxygen applied (lb/day) versus the TOD loading of the reactor. For loadings greater than 8 lb TOD/day, the quantity of oxygen supplied to the reactor ranged from 4 to 15 lb O₂ per day. Although the data suggest that 10 to 15 lb O₂/day could be delivered, most of the values fell within 6 to 10 lb/day. Hence, the useful operating capacity of the system would appear to fall within this range, which is in agreement with the manufacturers specifications (23).

Figure 8. Relationship of oxygen applied vs organic loading to the reactor.

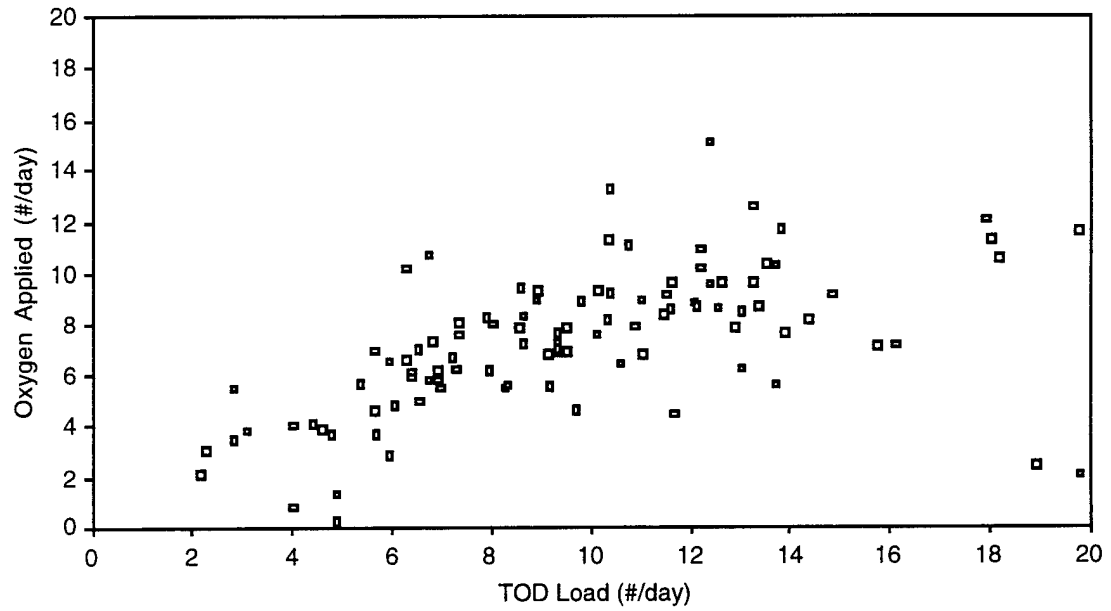

5.3.2 Nutrient requirements

Inorganic nutrients (urea and diammonium phosphate) were continuously added to the influent of the bioreactor based on the organic loading to satisfy a TOD:N:P ratio of 100:5:1. As the loading increased, the flow rate of nutrient solution was adjusted accordingly. Inorganic nutrient concentrations in the effluent were monitored weekly throughout the investigation; ammonium ion and orthophosphate concentrations ranged from 0.9 to 8.3 ppm, and 1.0 to 2.9 ppm, respectively (Appendix A).

Provision of sufficient levels of inorganic nutrients was shown to be important for maintaining high treatment efficiencies. On 2 occasions, transient excursions in effluent chlorobenzene concentrations may have been due to problems with the nutrient delivery system. For example, when the inlet filter plugged with an inorganic precipitate on Day 36, the effluent concentrations of ammonia and phosphate dropped below 0.2 ppm. Limiting nutrient conditions were likely responsible for a slight increase in effluent chlorobenzene concentration during this period.

5.3.3 Growth and biomass yield

Biological growth was monitored throughout the study by measuring changes in the bed height (Figure 9) as well as the effluent concentrations of total and volatile suspended solids. Expansion of the bed occurs when the density of the carbon particles decreases as a result of increases in the biofilm thickness. Based on previous experience (27), the rate of bed expansion varies with the organic carbon source and the growth rate of the microorganisms. Consequently, the gradual increase in bed height observed during the first 9 weeks of operation (Figure 9) may suggest a relatively slow growth rate for the chlorobenzene-degrading bacteria.

On Day 60, the bed height reached the 11-foot level and the biomass control system began operation, marking the beginning of "steady-

Figure 9. Changes in carbon bed height during operation of the reactor.

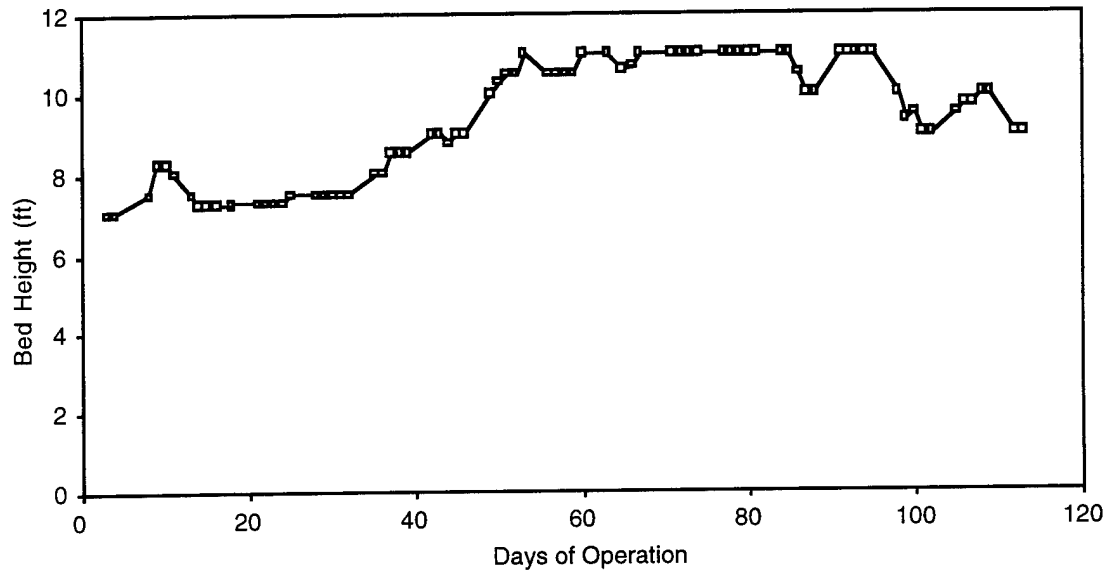

state" conditions in the reactor. Effluent samples were collected weekly and analyzed for suspended solids concentrations (Appendix A). The high proportion of volatile suspended solids as compared to the total solids indicates that the majority of the material was biological in nature. Total suspended solids levels ranged from 17 to 49 mg/L (mean = 34 mg/L) during the period from Day 60 to 92. Based on the average loss of 1.6 pounds of solids per day in the effluent, and a chlorobenzene loading of 6 lb/day, the cell yield was approximately 0.27.

5.3.4 pH control

The pH of the bioreactor increased slightly during startup (pH = 8.03), presumably due to adsorption of dissolved carbon dioxide on the activated carbon (22). Once biodegradation was noted in the system (Day 4), the pH gradually declined and 0.1 to 0.5N NaOH solution was automatically added to maintain the pH within control limits of pH 7.2 to 7.7. However, to minimize the potential for scaling due to the precipitation of calcium carbonate, the control set points were changed on Day 9 to the range of pH 6.6 to 6.8. Although some caustic solution was added to control pH from Day 9 to 15, further addition was not required beyond this point, and the pH of the reactor was relatively constant through Day 113 of operation. As shown in Figure 10, the influent pH varied between 5.7 and 6.3, while the effluent pH was relatively constant (ca. pH 6.9).

5.3.5 Volatile emissions

The air above the bioreactor was periodically monitored using an organic vapor analyzer to detect volatile losses of chlorobenzene from the system. Organic vapor concentrations ranged from trace to non-detectable levels, suggesting that biological treatment was the principal removal mechanism (data not shown).

Figure 10. Reactor influent (\square) and effluent pH (+).

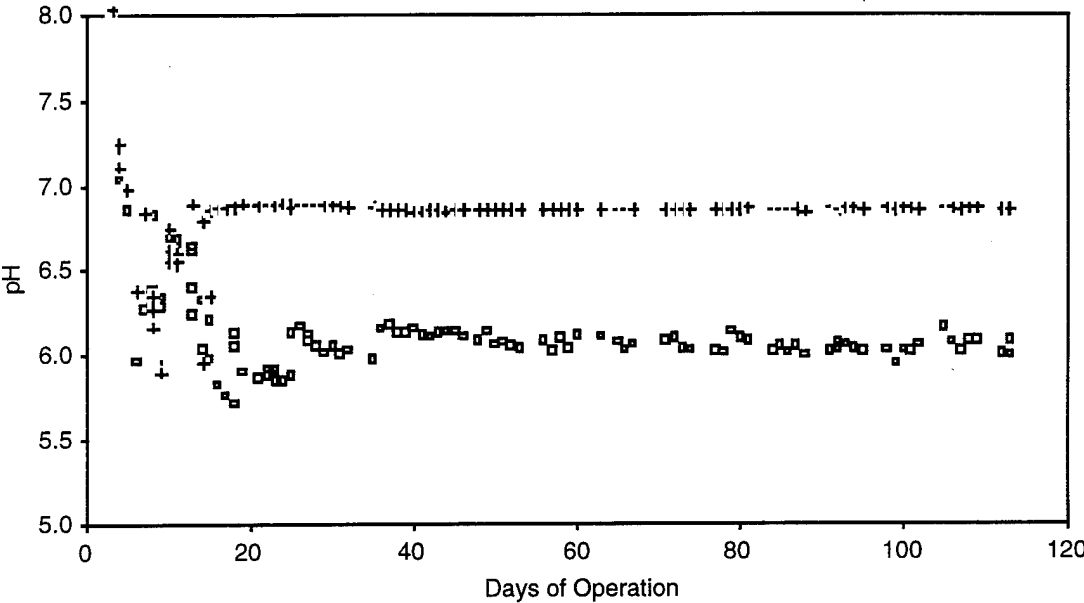

5.4 Effects of Shock Loading

Prior to the shock-loading experiment, the system exhibited stable performance at an influent flow rate of 4 gpm (Table 2). On Day 63, the groundwater flow was increased to 8 gpm, thereby doubling the organic loading to about 22.4 lb TOD/day (Appendix A). As shown in Figure 11, the effluent chlorobenzene concentrations rapidly increased from nondetectable to levels as high as 27.4 ppm during the shock. Based on the mean groundwater (115.2 ppm) and effluent (26.6 ppm) chlorobenzene concentrations, oxygen consumption in the reactor (29.7 mg/L), and the average groundwater (8 gpm) and recycle (28.4 gpm) flow rates, the mass balance for the system was as follows:

- a) Groundwater loading = 11.2 lb chlorobenzene/day
- b) Effluent losses = 2.6 lb chlorobenzene/day
- c) TOD consumption = 10.2 lb oxygen consumed/day
= 5.1 lb chlorobenzene degraded/day

During the peak of the excursion, about 45% of the chlorobenzene entering the reactor was removed by biodegradation, while 23% exited the system with the effluent. Hence, it is likely that adsorption accounted for approximately 32% of the removal observed during the experiment.

Once the flow rate was restored to 4 gpm, the levels of chlorobenzene in the effluent rapidly declined. Within 2 hours, the effluent concentrations dropped to 12 ppb, and within 2 days the levels were consistently below the detection limit of 10 ppb (Appendix A). To allow sufficient time for the reactor to recover prior to subsequent experiments, the system was operated from Day 65 to 92 at an influent flow rate of 4 gpm. Performance of the system during this period has been previously described.

Figure 11. Effects of shock loading on reactor performance. Changes in chlorobenzene concentration in the influent (\square -- \square) and effluent (\bullet -- \bullet) from the reactor.

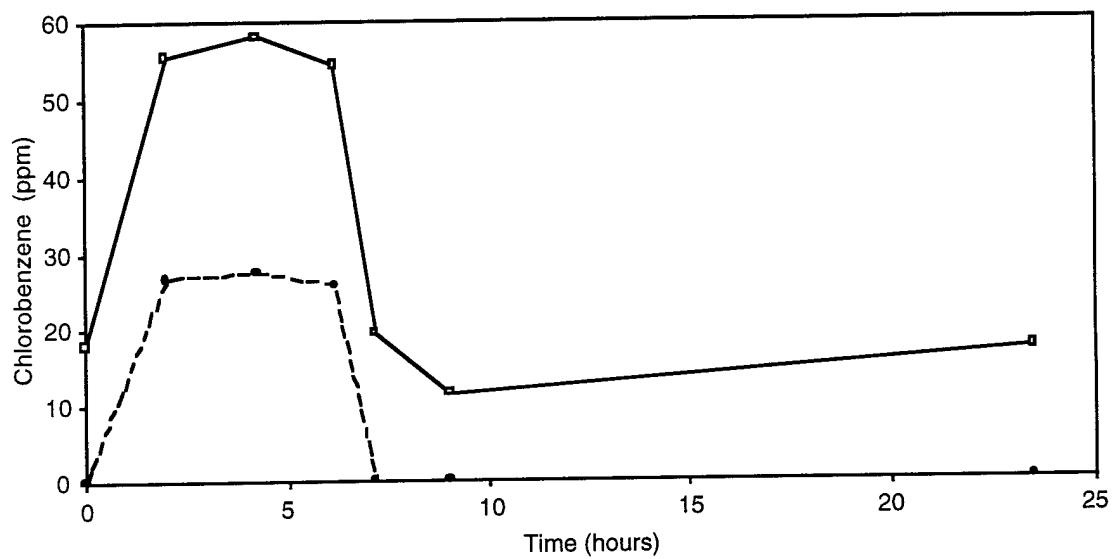

5.5 Operation at Excess Loading

To examine the effects of extended operation at organic loading rates exceeding the design capacity, the flow rate to the reactor was increased on Day 92 from 4 to 5 gpm, thereby increasing the organic loading to an average of 17.2 lb TOD per day. The study was conducted to push the unit to failure in an attempt to identify critical operating parameters as well as potential system improvements. Performance of the system gradually declined between Days 92 and 113 as indicated by oxygen limitations and increased levels of chlorobenzene in the effluent (Appendix A). However, the average treatment efficiency remained as high as 99%, as summarized in Table 3. Based on the mean concentrations of chlorobenzene in the groundwater (144.5 ppm) and the effluent (1.1 ppm), oxygen consumed in the reactor (22.2 mg/L), and the average influent (5 gpm) and recycle (29.6 gpm) flow rates, the mass balance for the system was as follows:

- a) Influent loading = 8.6 lb chlorobenzene/day
- b) Effluent losses = 0.1 lb chlorobenzene/day
- c) TOD consumption = 7.9 lb oxygen consumed/day
= 3.9 lb chlorobenzene degraded/day

Based on the influent loading, about 45% of the chlorobenzene entering the reactor was removed by biodegradation, while 1% exited with the effluent. These results suggest that approximately 54% (4.6 lb chlorobenzene per day) of the material was removed by adsorption, which would equate to about 101 lb of chlorobenzene adsorbed over the 22-day period. Since the reactor was initially loaded with 350 pounds of granular activated carbon, this amount is within the capacity of the adsorbant (32).

A variety of mechanical problems were encountered during operation under overloaded conditions and were primarily attributed to excessive biomass growth or oxygen limitations. A high degree of fouling of the effluent dissolved oxygen probe was experienced due to the increase in biomass, which necessitated daily cleaning. Measurements from the influent dissolved oxygen probe also became

Table 3. Summary of bioreactor performance data; operation at excess loading (Day 92 to 214).

Days	Flow (gpm)	Recycle Flow (gpm)	Bed Height (ft)	Temp (°C)	TOD Loading (lb/Day)	Feed Cl-ben (ppm)	Influent Cl-ben (ppm)	Effluent Cl-ben (ppb)	Influent TOD (ppm)	D.O. Consumed (ppm)	DO/TOD (p/p)	Treatment Efficiency (% of Feed)
92-113	5.0	29.6	9.9	25.4	17.2	144.5	26.3	1087.0	52.6	22.2	0.42	99.25
113-130	3.5	29.5	9.0	24.1	10.2	123.2	12.3	506.7	24.5	24.4	1.00	99.59
131-134	3.5	29.3	8.7	18.9	10.1	124.2	63.2	48000.0	126.4	28.1	0.22	61.35
135-155	1.2	31.1	7.6	23.1	4.0	112.3	11.6	1903.9	25.2	4.5	0.18	98.30
155-182	1.3	32.5	7.3	22.1	4.5	115.5	5.4	819.3	11.4	10.3	0.91	99.29
183-197	2.0	34.4	9.0	19.6	5.6	118.5	7.1	7.7	14.1	12.6	0.89	99.99
198-214	2.6	32.2	10.7	21.8	7.0	109.5	9.7	ND	19.4	18.2	0.94	>99.5 or >99.99

inconsistent when compared with the high oxygen flow rates (Appendix A). As a result, there is some uncertainty in the mass balance calculations previously described, although the magnitude of oxygen consumption in the reactor (7.9 lb/day) is within the expected operating capacity of the system. Because the inconsistency in the measurements did not appear to be caused by excessive biomass fouling of the influent probe, incompatibility of the sensor membrane with the higher influent chlorobenzene concentrations was initially suspected. The problem was later traced to the buildup of a thin film on the membrane which required more rigorous cleaning to remove.

The increased biomass also caused excessive clumping and packing of the carbon particles which appeared to create channels within the fluidized bed. To correct the problem, frequent bed soundings with a large weight were required to break up the clumps. In some cases, a length of plastic pipe was used to apply sufficient agitation to break up large clumps in the bed. It is likely that the increased extent and frequency of agitation of the bed resulted in significant losses of biomass from the system, and may account for the decline in the bed height noted from Days 98 to 113 (Figure 9). In addition, the loss of active biomass would be expected to contribute to lower treatment efficiency.

On Day 113, the flow rate to the reactor was decreased to 3.5 gpm, thereby lowering the organic loading to within the design capacity (Table 3). Over the next 18 days, performance of the system appeared to be returning to normal (Appendix A). The carbon bed expanded from 8 to 10 feet in height, consistent with microbial growth in the system. Effluent chlorobenzene concentrations were typically below the detection limit, and treatment efficiencies generally exceeded 99.5%. The ratio of oxygen consumption to the influent oxygen demand ranged from 0.6 to as high as 3.1, with an average of 1.0. The fact that the oxygen consumption frequently

exceeded the influent demand would be consistent with biological regeneration of the activated carbon (i.e., biodegradation of adsorbed materials).

During the early morning of Day 131, a cold front moved across the site, and the air temperature may have dropped to as low as -2°C . The impact on the reactor temperature is unknown. Because this change occurred over the weekend, the reactor continued operation unattended until the morning of Day 133. Observations recorded that morning indicated the system had experienced a severe upset, since levels of chlorobenzene in the effluent had increased to 31.8 mg/L (Appendix A). By Day 134, the effluent concentrations reached 64.3 mg/L. Due to the significant loss of performance, the reactor was operated at flow rates between 0 and 1 gpm over the next 3 weeks (Days 133 to 154). Attempts to increase the flow rate above this level generally resulted in elevated levels of chlorobenzene in the effluent, in spite of the fact that effluent dissolved oxygen concentrations were as high as 9.6 mg/L. During this period, a substantial decrease in the carbon bed height was also observed, and levels fluctuated between 7 and 8 feet. Although key components of system, including dissolved oxygen sensors, nutrient deliver equipment, etc., were checked and shown to be fully operational, attempts to restore performance of the system were unsuccessful.

On Day 155, the reactor was reseeded as before with 30 gallons of activated sludge. The system was operated on internal recycle for 3 days, and then the flow rate was increased to 1 gpm. After 6 days, oxygen consumption across the reactor was consistent with the influent TOD loading (Appendix A).

During the final 53 days, the reactor was operated for 2- to 4-week intervals at average groundwater flow rates of 1.3, 2 and 2.6 gpm, corresponding to organic loadings on the order of 4.5, 5.6 and 7 lb TOD per day, respectively (Table 3). Treatment efficiencies continued to improve during this period, and during the final 4 weeks of operation, met or exceeded 99.99%.

5.6 Effects of Temperature

Over the 214 day study, the operating temperature of the bioreactor varied in response to summer, fall and winter conditions (Figure 12 and Appendix A). Temperature was monitored at the inlet and outlet of the column, but was not controlled. During the initial startup, the morning temperatures were in the range of 28 to 31°C, and might climb to as high as 35°C by mid-day. Average operating temperatures during the first 92 days of operation decreased from 31.1 to 26.8°C, while treatment efficiencies generally exceeded 99.99% (Table 2). As the study continued into the fall and winter (Days 92 to 214), the operating temperatures continued to decline (Table 3). Although treatment efficiencies also decreased during this period, the relationship between temperature and performance is difficult to define, since other variables were involved. For example, while loading the bioreactor at 17 lb TOD per day (Days 92-113), the operating temperature of the system ranged from 22.2 to 29.5°C. Although the decline in treatment efficiency was likely the result of limiting dissolved oxygen concentrations, a number of mechanical problems may also have contributed. When the loading was returned to a range within design capacity (Days 113-130), the system appeared to recover and achieve high treatment efficiencies. Operating temperatures during this period ranged from 20.2 to 28.1°C.

Based on previous field experience, sudden large temperature decreases have been reported to have a significant impact on the performance of GAC-fluid bed bioreactors (33). A temperature drop may have caused the system failure which occurred between Days 131 and 133. No other explanations are evident at this point, since prior to failure, the system appeared to have recovered from the period of excess loading, and treatment efficiencies had increased to as high as 99.99%. Whatever caused the failure of the system on Day 131 appears to have had a significant detrimental effect on the microbial community, since attempts to restore operation by decreasing the organic loading were unsuccessful. In contrast,

Figure 12. Reactor temperature.

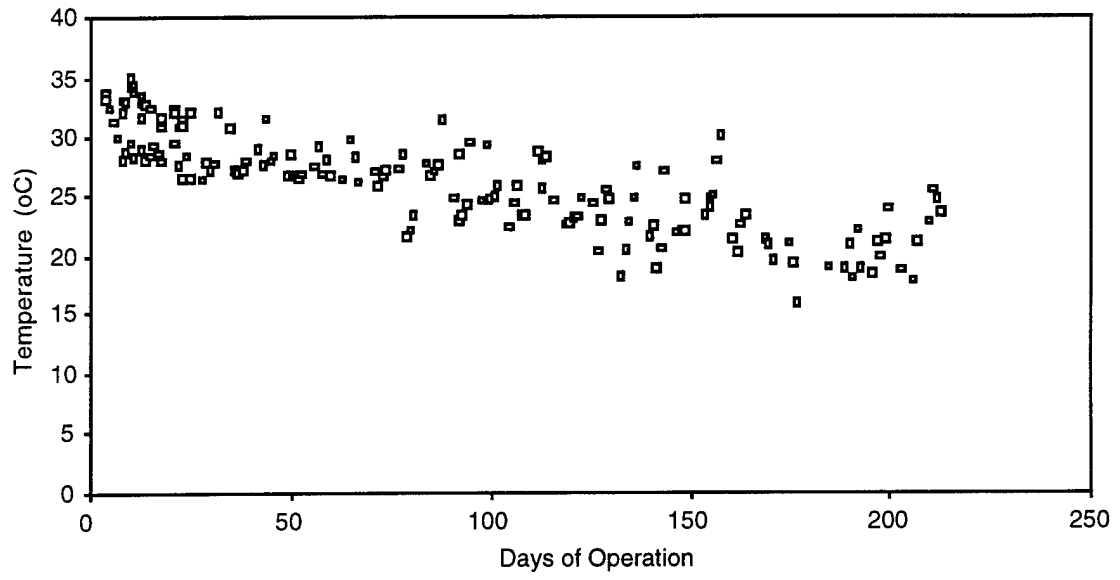

reactor performance was quickly re-established after reseeded with activated sludge. Although the average operating temperatures during this second startup (Days 155-214; 20 to 22°C) were lower than during the first (Days 1-43; 27 to 31°C), comparison of the data in Tables 2 and 3 suggests that the reactor performance was essentially the same.

6.0 ECONOMIC ANALYSIS

A series of scenarios were developed for comparison of the costs of groundwater treatment using the GAC fluid-bed bioreactor with a number of conventional technologies. A matrix of 4 case studies was developed on the basis of 2 flow rates and 2 groundwater concentrations as follows:

- Case 1. 30 gpm flow and 30 ppm chlorobenzene
- Case 2. 30 gpm flow and 150 ppm chlorobenzene
- Case 3. 150 gpm flow and 30 ppm chlorobenzene
- Case 4. 150 gpm flow and 150 ppm chlorobenzene

For each case, the capital, operating and maintenance costs for a number of groundwater treatment technologies were estimated. The treatment technologies included:

- A) Liquid-phase activated carbon adsorption
- B) Air stripping with vapor-phase carbon adsorption
- C) Air stripping with thermal oxidation
- D) GAC fluid-bed bioreactor

Each of the 4 treatment systems were functionally equivalent based on the ability to achieve an effluent discharge limit of 5 ppb.

6.1 Process Design

AspenPlus process simulation software was used to simulate the treatment process and determine the material and energy balance for each of the 16 technology and case study combinations. A general process schematic for each treatment technology is shown in Figures 13 to 16.

6.1.1 Liquid-phase activated carbon adsorption

Liquid-phase GAC adsorption was accomplished using 2 carbon beds in series (Figure 13). The third bed in the design is off-line to allow the spent carbon to be changed. The systems for treatment of 30 gpm flow rates consist of 5 foot tall by 5 foot diameter vessels filled with bulk carbon. The process design for 150 gpm flow rates required 6 foot tall by 6 ft diameter vessels. Carbon loading data was supplied by Calgon Carbon Corp. (34). Loading capacities for influent concentrations of 30 and 150 ppm were 62.5 and 83.3 mg chlorobenzene per gram of carbon, respectively.

6.1.2 Air stripping with vapor-phase carbon adsorption

Figure 14 shows the basic design of the system used for air stripping with vapor-phase carbon treatment. In designing the air stripper, the vapor-liquid equilibrium for chlorobenzene was predicted to be non-ideal, so the UNIQUAC activity coefficient equation was used (35). Binary interaction constants were estimated from the chemical structure. The size of the stripper tower varied depending on the groundwater flow rate and chlorobenzene concentration. The diameter of the column ranged from 1.2 to 2.6 feet for groundwater flow rates of 30 and 150 gpm, respectively. Similarly, the height of the column ranged from 34 to 40 feet for influent chlorobenzene concentrations of 30 and 150 ppm, respectively. The height of the packing was estimated using the procedure described by Treybal for calculating the number of overall liquid-phase mass transfer units (36). The stripper towers were packed with polypropylene packing.

The vapor phase was treated using a 2 carbon beds in series. Since humidity reduces adsorption capacity, an air blower was placed between the stripper and the carbon beds to raise the gas temperature by approximately 4 C, thereby lowering the relative humidity. For convenience, 55 gallon single-use canisters were used for the the cases with lower chlorobenzene loadings (Cases 1B and

Figure 13. Process flow diagram for simulation of liquid-phase activated carbon adsorption.

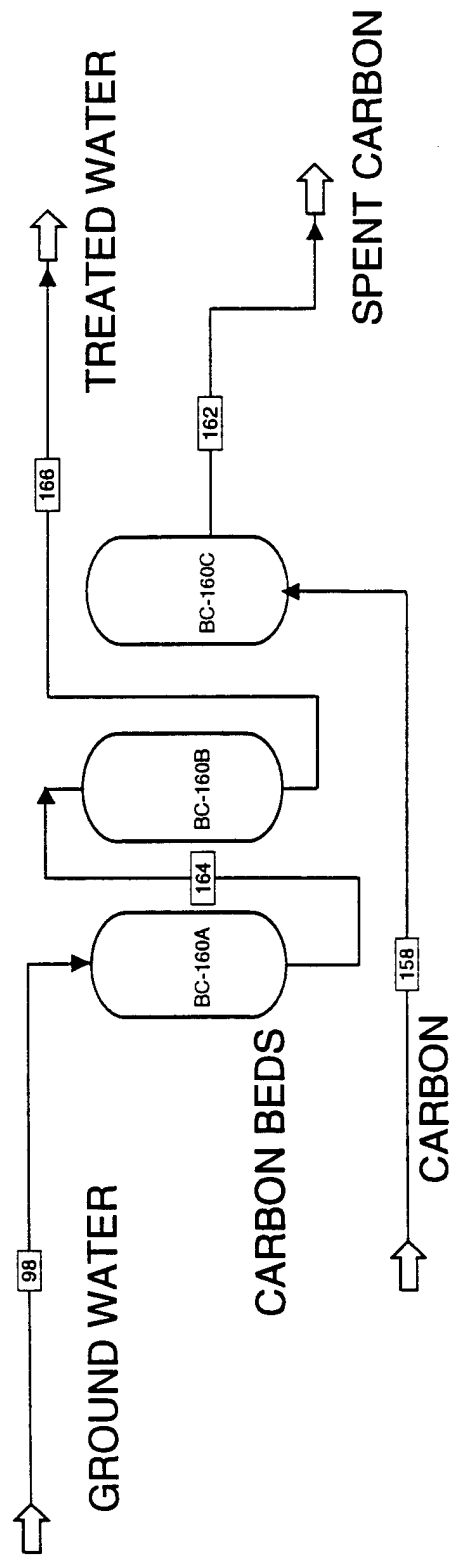

3B), whereas 8 foot tall by 8 foot diameter vessels filled with bulk carbon were used for cases with higher chlorobenzene concentrations (Cases 2B and 4B). Carbon loading data for vapor-phase treatment was supplied by Calgon (34). At partial pressures of 0.0017 and 0.0087 psia, chlorobenzene loadings were reported to be 32 and 42% by weight, respectively. These values were reduced by 50% to account for humidity and by a factor of 0.85 to account for efficiency. For influent chlorobenzene concentrations of 30 and 150 ppm, the vapor-phase loading capacities were 13.6 and 17.9% by weight, respectively.

6.1.3 Air stripping with thermal oxidation

As shown in Figure 15, chlorobenzene removed by air stripping was also treated using a thermal oxidizer. The system was designed with an economizer on the air side of the thermal oxidizer to recover heat, thereby minimizing fuel consumption. A forced draft fan pulls air through the stripper and pushes it into the thermal oxidizer. For safety, the concentration of combustible organics in the vapor phase from the stripper must be less than 25% of the lower explosive limit. An induced draft fan provides the required safe draft on the incinerator and pushes the flue gas through the air pollution control scrubber. The flue gas leaving the thermal oxidizer is scrubbed by contacting it with the treated groundwater.

The air stripper and the flue gas scrubber were designed using the same criteria as described above. The thermal oxidizer was sized using a factor of 200 standard cubic feet per minute of air per million BTU per hour and applying a safety factor of 30% to the air flow rate. The economizer was designed using an estimated heat transfer coefficient of 24 BTU per hour per square foot per degree-F and a safety factor of 50%.

Treated groundwater was used to scrub hydrogen chloride present in the flue gas to eliminate any additional hydraulic loading to the discharge. This would add approximately 10 ppm to 50 ppm of HCl to

Figure 15. Process flow diagram for simulation of air stripping with thermal oxidation.

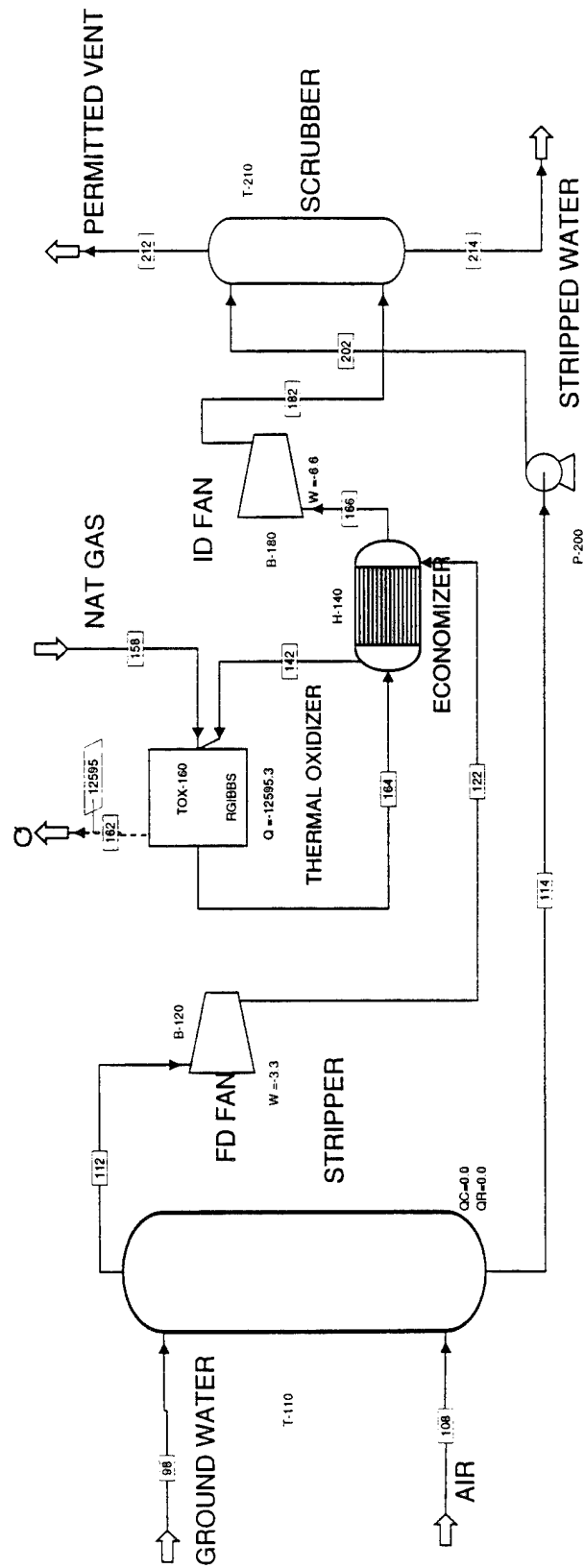

the discharge water depending on the initial chlorobenzene concentration. It was assumed that the groundwater would have sufficient buffering capacity to accommodate the acidity to avoid additional costs. When the alkalinity of the groundwater is low, additional neutralization may be required.

6.1.4 GAC fluid-bed bioreactor treatment

The design for the process simulation of the GAC fluid-bed bioreactor was based on the Envirex system (Figure 16). The height and diameter of the biological reactor were sized to achieve flux rates of 13 gpm per square foot and a hydraulic residence times of 7 minutes. For the process simulation, the diameter of the reactor vessel varied from 2.5 to 13 feet and the height from 16 to 21 feet depending on the flow rate and chlorobenzene concentration. The recycle flow rate was calculated from the greater of a) 30 gpm, b) 25% of the feed, or c) 2.9 gpm per pound of TOD per day. A minimum flow of 30 gpm through the bioreactor was assumed in order to fluidize the carbon bed. To buffer any potential step changes in the feed concentration, the system was designed with a minimum of 25% recycle. The organic loading capacity of the reactor was based on the solubility of oxygen in the reactor feed stream (32 ppm).

6.2 Basis of Economic Analysis

A number of factors are expected to influence the costs for treating groundwater with the various technologies. These include groundwater flow rate, nature and concentration of the contaminants, groundwater chemistry, physical site conditions, geographical location, size of the contaminant plume, and the treatment goals. In addition, the length of time that will be required to satisfactorily remove the contaminants adds considerable uncertainty to the remedial design. Because most pump-and-treat groundwater remediation projects are long term, the analysis assumes that the treatment project will last at least 10 years.

Figure 16. Process flow diagram for simulation of the GAC fluid-bed bioreactor.

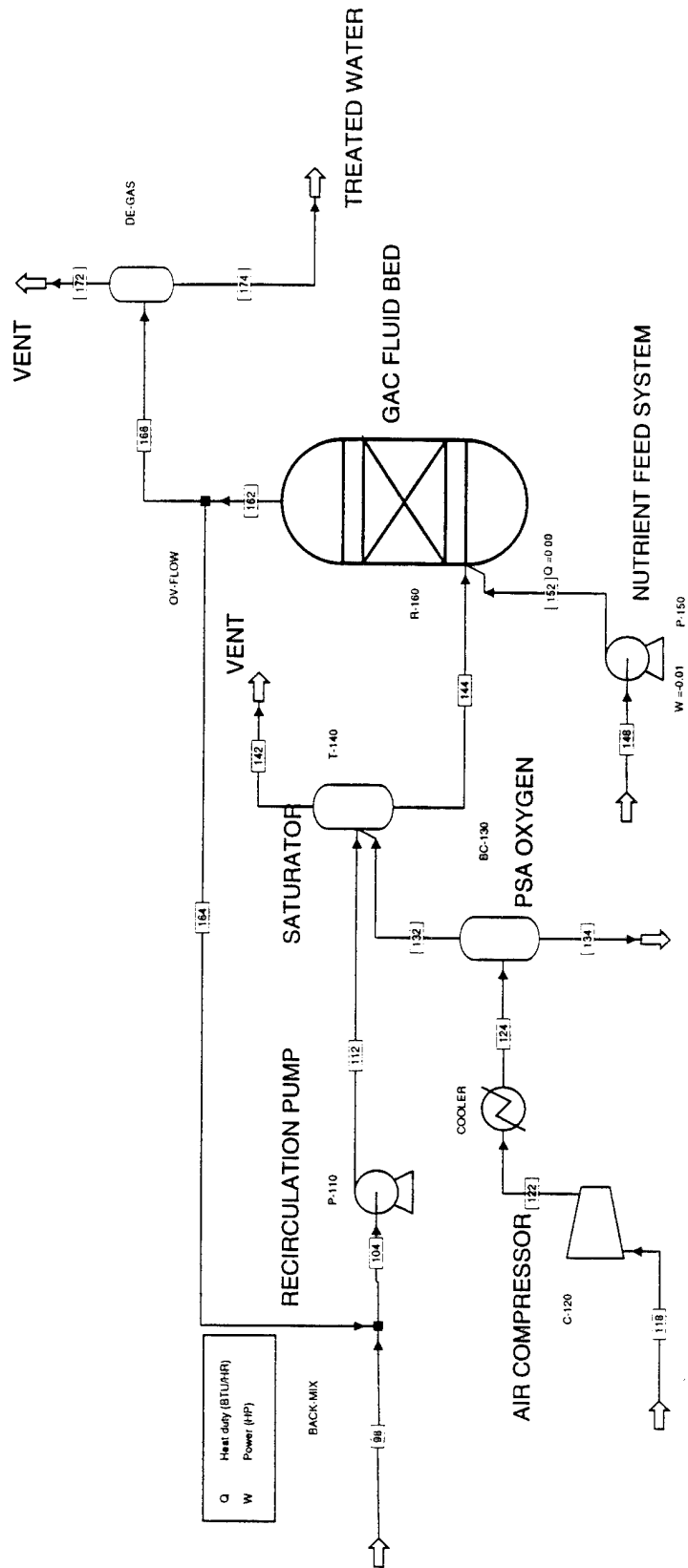

The economic analysis assumes that the contaminated groundwater will be pumped to the various treatment systems. Since the costs for installing extraction wells and delivery pipelines will be highly site dependent, they have not been considered. Discharge requirements are also expected to be site specific. For the present analysis, water treated by GAC adsorption or air stripping (coupled to either vapor-phase carbon adsorption or thermal oxidation) was assumed to be discharged to surface water at no cost. In contrast, due to the presence of suspended solids in the effluent from the GAC fluid-bed bioreactor, additional disposal costs may be incurred. For cases 1 and 3, effluent suspended solids concentrations in the range of 8 mg/L (based on 30 ppm chlorobenzene and a yield of 0.27) may be sufficiently low to permit direct discharge. In contrast, the levels of suspended solids resulting in cases 2 and 4 may warrant disposal of the effluent to a local publicly owned treatment works (POTW). Because of the uncertainty in discharge requirements, groundwater treatment costs for the bioreactor are presented with and without POTW disposal costs. For the present analysis, POTW charges were assumed to be \$3.00 per 1000 gallons.

The following assumptions were also made for each case in this analysis:

- The groundwater contains low levels of iron and manganese and will not require pretreatment other than coarse filtration
- Utilities, including natural gas and electricity, are readily available at the site
- The treatment system will operate automatically
- A part-time technician will be required to operate the equipment, collect all required samples, and perform equipment maintenance and minor repairs
- One treated water sample and one untreated water sample will be collected daily to monitor system performance

- Treated and untreated water samples will be collected monthly and analyzed by an independent laboratory
- Costs of major repairs are included
- Taxes and insurance costs have not been included.

6.3 Cost Categories

Groundwater treatment costs can be subdivided into a series of categories based on previous experience at Superfund and RCRA corrective action sites (37). For the economic analysis, costs were allocated for the following categories: (1) site preparation, (2) permitting and regulatory requirements, (3) capitalized equipment, (4) startup, (5) demobilization, (6) labor costs for both operating staff and any necessary training, (7) consumables and supplies, including activated carbon and inorganic nutrients, (8) natural gas and electric power utilities, (9) analytical services, and (10) maintenance. Costs associated with each category are discussed below.

Site preparation costs include administration, treatability studies, and engineering costs. For this analysis the costs are estimated to be a one-time charge of \$50,000. These costs are independent of the contaminant concentration and flow rate.

Permitting and regulatory costs are also assumed to be independent of the contaminant levels and flow rate. However, they will be highly dependent on whether treatment is performed at a Superfund or a RCRA corrective action site. For this analysis, these costs are estimated to be a one-time charge of \$50,000.

Capitalized equipment costs include purchasing and installing all treatment equipment. For this analysis, the costs of the equipment described in each process simulation (Figures 13 to 16) were estimated using the Dow Factored Cost Estimation Program (data not shown). Capital costs also include instrumentation, computer control, and minimum shelter for the computer and any sensitive

analytical equipment. When size permits, the process equipment will be pre-fabricated on skids and delivered to the site ready for start-up. Costs directly associated with equipment startup are included.

Expenses in the startup category include additional costs for developing a health and safety program for the site and one-time operator training costs. For this analysis, the startup costs are estimated to be \$4000.

Demobilization costs include shut-down, disassembly and disposal of the equipment at a facility for hazardous waste. This analysis assumes that the equipment will have no salvage value at the end of the project. The costs were calculated based on a fixed charge of \$7500 plus a variable 2% of the original capital cost. Since these costs will occur at the end of the project, they have been discounted to the present value.

Labor expenses are based on the assumption that each system will only require a part-time operator. Labor costs were estimated at \$40,000 plus \$3000 per year for annual health monitoring and safety training.

Consumables and supplies include personal protective equipment (e.g. steel-toed boots, full-face respirators and cartridges, gloves and safety glasses) that are predicted to cost \$600 per year. Groundwater filtration costs of \$50 per 300,000 gallons include purchase of new filter bags and associated disposal as hazardous waste. Miscellaneous expenses for oil, replacement gauges, pump seals and spare parts may also be incurred.

Activated carbon will be purchased either as 55-gallon single-use drums or in bulk. A single-use drum contains 200 pounds of carbon and costs \$1300, which includes delivery and reprocessing. Single-use drums were used only for air stripping cases 1B and 3B. Bulk carbon was used for all other applications. The cost of bulk carbon

for liquid-phase treatment was \$1.25 per pound which includes delivery and reprocessing. Bulk carbon for vapor phase treatment was \$1.75 per pound.

Nutrient costs were calculated from the stoichiometry of addition to satisfy a TOD:N:P ratio of 100:5:1. Based on the cost of the nutrient mixture, operating costs were estimated to be \$0.13 per pound of TOD.

Utility costs included natural gas at \$4.00 per thousand standard cubic feet (10^6 BTUs) and electricity at \$0.08 per kilowatt-hour.

Analytical services costs include daily analysis of treated and untreated water samples. In addition, one sample per month will be analyzed at an independent laboratory. The independent laboratory will prepare monthly reports and yearly summaries.

Maintenance costs for each case were calculated as a percentage of the capitalized equipment costs. Maintenance costs are likely to be low during the first year of operation, higher in the last year, and highly variable. For this analysis, the costs were estimated to be an average of 5% of the capitalized equipment costs per year.

6.4 Treatment Costs

Cost estimates for each of the 4 treatment technologies for the 4 cases are presented in Tables 4 to 7. The costs were projected over a 10-year period. The total one-time costs are those that occur only once during the life of the project and include site preparation, permitting and regulatory expenses, capitalized equipment, startup and demobilization. The one-time costs were divided equally over the 10-year life of the project and added to the total yearly operating and maintenance (O&M) costs (labor, consumables, utilities, analytical, etc) to calculate the total yearly costs. Treatment costs in dollars per 1000 gallons were calculated from the total yearly cost at the stated flow for 8000 hours per year.

This value was selected to accommodate any down time that may be required for maintenance or repair of either the groundwater recovery or treatment systems. All costs are presented in 1994 dollars and are considered to be order-of-magnitude estimates.

Comparison of the data presented in Tables 4 through 7 indicates that for a given flow rate, the cost of groundwater treatment (in \$/1000 gallons) generally increases as the concentration of the contaminants increases. However, economy of scale differences are also readily apparent, since unit treatment costs for the higher flow rates were generally cheaper than those for lower flows.

Of the 4 technologies examined, the costs for groundwater treatment using the GAC fluid-bed bioreactor were generally lower as compared to the more conventional methods. Bioreactor costs ranged from \$2.00 to \$13.00 per 1000 gallons, and were highly dependent on the influent concentration, flow rate and potential POTW disposal charges. Groundwater treatment by liquid-phase carbon adsorption was the most expensive (\$7.00 to \$27.00 per 1000 gallons), primarily because of the costs for replacement and disposal of the spent carbon. Air stripping with vapor-phase adsorption was more expensive than air stripping coupled to thermal oxidation. At the higher flow rates, the costs for the latter are estimated to be about half of those for systems with vapor-phase carbon treatment.

Additional differences between the 4 technologies are evident from a comparison of capital and yearly operating and maintenance costs. Capital costs for liquid-phase adsorption and air stripping with vapor-phase adsorption were among the lowest, ranging from \$280,000 to \$363,000 and from \$102,000 to \$640,000, respectively. In contrast, yearly operating and maintenance costs for these two methods were very high, ranging from \$150,000 to \$1,500,000, with the bulk of the expense associated with carbon replacement. Capital costs for GAC fluid-bed bioreactor were also relatively low, ranging from \$143,000 to \$607,000. Note that while these capital

Table 4. Economic analysis of liquid-phase carbon adsorption.

	Case 1A	Case 2A	Case 3A	Case 4A
Flow rate (gpm)	30	30	150	150
Chlorobenzene (ppm)	30	150	30	150
Site preparation	50000	50000	50000	50000
Permitting and regulatory	50000	50000	50000	50000
Capital equipment	280000	280000	363000	363000
Startup	4000	4000	4000	4000
Demobilization	13100	13100	14760	14760
Total one-time costs	397100	397100	481760	481760
Labor				
Operating staff	40000	40000	40000	40000
Training	3000	3000	3000	3000
Consumables/supplies	3000	3000	12600	12600
Activated carbon	72000	270000	360000	1352000
Nutrients				
Utilities				
Natural gas				
Electrical	1432	1432	1432	1432
Analytical services	24000	24000	24000	24000
Maintenance	14000	14000	18150	18150
Total annual O&M costs	157432	355432	459182	1451182
Total yearly costs (10 yr)	197142	395142	507358	1499358
Cost per 1000 gallons	13.69	27.44	7.05	20.82

Table 5. Economic analysis of air stripping with vapor-phase carbon adsorption.

	Case 1B	Case 2B	Case 3B	Case 4B
Flow rate (gpm)	30	30	150	150
Chlorobenzene(ppm)	30	150	30	150
Site preparation	50000	50000	50000	50000
Permitting and regulatory	50000	50000	50000	50000
Capital equipment	102000	190000	219000	640000
Startup	4000	4000	4000	4000
Demobilization	9540	11300	11800	20300
Total one-time costs	215540	305300	334880	764300
Labor				
Operating staff	40000	40000	40000	40000
Training	3000	3000	3000	3000
Consumables/supplies	3000	3000	12600	12600
Activated carbon	150800	144200	743600	722400
Nutrients				
Utilities				
Natural gas				
Electrical	1909	1909	3818	3818
Analytical services	24000	24000	24000	24000
Maintenance	5100	9500	10950	32000
Total annual O&M costs	227809	225609	837968	837818
Total yearly costs (10 yr)	249363	256139	871456	914248
Cost per 1000 gallons	17.32	17.79	12.10	12.70

Table 6. Economic analysis of air stripping with thermal oxidation.

	Case 1C	Case 2C	Case 3C	Case 4C
Flow rate (gpm)	30	30	150	150
Chlorobenzene(ppm)	30	150	30	150
Site preparation	50000	50000	50000	50000
Permitting and regulatory	50000	50000	50000	50000
Capital equipment	724000	736000	2197000	2223000
Startup	4000	4000	4000	4000
Demobilization	21980	22220	51440	51960
Total one-time costs	849980	862220	2352440	2378960
Labor				
Operating staff	40000	40000	40000	40000
Training	3000	3000	3000	3000
Consumables/supplies	3000	3000	12600	12600
Activated carbon				
Nutrients				
Utilities				
Natural gas	1659	929	8394	4470
Electrical	5011	5011	16942	16942
Analytical services	24000	24000	24000	24000
Maintenance	36200	36800	109850	111150
Total annual O&M costs	112870	112740	214787	212162
Total yearly costs (10 yr)	197868	198962	450031	450058
Cost per 1000 gallons	13.74	13.82	6.25	6.25

Table 7. Economic analysis of GAC fluid-bed bioreactor.

	Case 1D	Case 2D	Case 3D	Case 4D
Flow rate (gpm)	30	30	150	150
Chlorobenzene(ppm)	30	150	30	150
Site preparation	50000	50000	50000	50000
Permitting and regulatory	50000	50000	50000	50000
Capital equipment	143000	284000	284000	607000
Startup	4000	4000	4000	4000
Demobilization	10360	13180	13180	19640
Total one-time costs	257360	401180	401180	730640
Labor				
Operating staff	40000	40000	40000	40000
Training	3000	3000	3000	3000
Consumables/supplies	3000	3000	12600	12600
Activated carbon				
Nutrients	936	4680	4680	23400
Utilities				
Natural gas				
Electrical	4295	14795	14795	48202
Analytical services	24000	24000	24000	24000
Maintenance	7150	14200	14200	30350
Total annual O&M costs	82381	103675	113275	181552
Total yearly costs (10 yr)	108117	143793	153393	254616
Cost per 1000 gallons	7.51	9.99	2.13	3.54
With POTW disposal costs		12.99		6.54

estimates were derived from the process simulation and the individual component costs, they are comparable to the costs of commercially available skid mounted bioreactors. Of the technologies examined, capital costs for the air stripper and thermal oxidizer system were the most expensive, ranging from \$720,000 to \$2,200,000. However, the air stripper/thermal oxidizer and the GAC fluid-bed bioreactor both had lower yearly operating and maintenance costs.

7.0 CONCLUSIONS

The objective of this project was to evaluate the utility of an Envirex GAC fluid-bed bioreactor system to treat chlorobenzene contaminated groundwater. Reactors of this type are commercially available, and have been widely used for treatment of groundwater and process water containing readily biodegradable aromatic hydrocarbons, such as mixtures of benzene, toluene, ethylbenzene and xylene (BTEX; [9-12]). In contrast, the application of bioreactors for treatment of chlorinated organic compounds has been limited. Recently however, specialized microbial processes have been discovered, and it is now known that a variety of chlorinated aliphatic and aromatic hydrocarbons can be utilized by microorganisms as carbon sources for growth (13-21, 38-41). These discoveries expand the range of contaminants susceptible to biotreatment, thereby expanding the range of applications for this cost-effective treatment technology.

An important consideration before the field study was the identification of the source of inoculum to be used to seed the bioreactor. On the basis of previous work by Spain and co-workers (19-21), the initial plan was to use Pseudomonas strain JS150. During a 3-week demonstration conducted at Kelly Air Force Base, upflow fixed-film reactors inoculated with the organism were highly effective in treating groundwater containing a mixture of aromatic and chloroaromatic hydrocarbons (20). However, microbiological analysis of the reactor indicated that strain JS150 was eventually displaced by native microorganisms present in the groundwater (21). These results suggested that bacteria indigenous to contaminated sites could be used to seed a bioreactor, and prompted an investigation of the distribution of chlorobenzene bacteria at the present study site. Competent bacteria were readily isolated from enrichment cultures inoculated with either activated sludge or contaminated groundwater. Microbiological analysis of the cultures suggested that on the basis of colony morphology on solid media, at least 6 distinct chlorobenzene-degrading bacteria were

present in cultures inoculated with activated sludge, while 2 distinct types were isolated from the groundwater. As a result, activated sludge from the site was used to inoculate the reactor during startup. However, in view of the work of Nishino et al (21), since chlorobenzene-degrading bacteria were present in the groundwater it is likely that upon extended operation of the bioreactor, the organisms present in the inoculum were eventually displaced.

To evaluate performance over a range of operating conditions, organic loading to the reactor was periodically increased by adjusting the groundwater flow rate. Chlorobenzene treatment efficiencies exceeding 99.99% were achieved at loading rates within the design capacity (6-10 lb TOD/day) at a hydraulic residence time of 7 minutes. Although chlorobenzene concentrations in the groundwater varied from 100 to 170 ppm, performance of the reactor was essentially constant and effluent chlorobenzene concentrations were consistently below the detection limit. At loading rates of 5 and 9 lb TOD/day, the ratio of oxygen consumption to the influent TOD concentration ranged between 0.93 and 0.99, suggesting that biodegradation was the principal removal mechanism. Volatilization from the reactor was negligible, since periodic analysis of the organic vapor concentrations around the reactor revealed trace to nondetectable levels. These results are consistent with previous reports describing the performance of GAC fluid-bed bioreactors during full-scale evaluations (42). Removal efficiencies exceeding 99% have been frequently reported for treatment of groundwater containing mixtures of aromatic hydrocarbons resulting from fuel spills (9-11). Recently, Eckel et al (43) described similar performance for the biological treatment of groundwater containing a complex mixture of volatile and semivolatile organic compounds which included several chloroanilines and chloronitrobenzenes.

When the bioreactor was operated at organic loading rates in excess of the design capacity, adsorption also appeared to play a role in

maintaining high treatment efficiencies. At loading rates of 12 lb TOD/day, chlorobenzene removal efficiencies continued to exceed 99.99%, however, the ratio of oxygen consumption to the influent TOD concentration decreased to 0.78. The treatment efficiency decreased to an average of 99.3% when the reactor was operated at 17 lb TOD/day. A mass balance for the system at the higher loading suggested that approximately 45% of the chlorobenzene entering the reactor was removed by biodegradation, 54% was adsorbed, and 1% exited with the effluent. Adsorption capacity expended during operation at the higher loading was biologically regenerated as evident by the fact that oxygen consumption frequently exceeded the influent TOD concentration when the loading was decreased from 17 to 10 lb TOD/day. The adsorption capacity of the system also serves to dampen the effects of loading changes caused by variability in the groundwater composition. In addition, treatment efficiencies did not appear to be affected by step changes in groundwater flow rate, which increased loading to the reactor by 1.4-fold increments (e.g., 8.5 to 12 lb TOD/day). In contrast, the adsorption capacity of the carbon was ineffective in dampening the effects of a major shock load. When loading to reactor was doubled from 12 to 24 lb TOD per day, effluent chlorobenzene concentrations rapidly increased. However, the effects were temporary, since the effluent concentrations rapidly declined when the loading was restored to prior levels.

The maximum organic loading capacity of the bioreactor is a function of the ability to provide sufficient oxygen for biodegradation. Furthermore, the ability to satisfy the oxygen demand was shown to have the greatest effect on maintaining high treatment efficiencies. With the current design, the capacity to provide dissolved oxygen is controlled by the purity of oxygen gas produced by the oxygen generator and the transfer efficiency of the injection, bubble trap and eductor system. According to the manufacturer, the capacity of the current design is in the range of 6 to 10 lb O₂ per day (23). Although observations during the present study suggested that as high as 15 lb O₂ per day could be delivered,

the majority of the values fell below 10, consistent with manufacturers specifications. Recently, Envirex has developed and began testing a new pressurized bubble contactor which reportedly can achieve significantly higher oxygen transfer efficiencies (27). Preliminary indications suggest that with the new design, the loading capacity of the bioreactor can be increased by 50 to 100%.

A variety of problems were experienced during the field study, many of which occurred during the period of operation at excessive loading. Fouling of both the influent and effluent dissolved oxygen probes was a constant problem due to increased biomass production. The accumulation of a thin film on the sensor membranes was also noted, which required more rigorous cleaning to remove. During prolonged periods of operation, repeated problems with the oxygen sensors could have a significant impact on the reliability of a bioreactor. Since accurate oxygen measurements are critical for control of the delivery system, consideration of self-cleaning oxygen electrodes is highly recommended. Plugging of the nutrient delivery system also created problems and affected reactor performance. Because of the composition of the nutrient mixture and the inorganic ions present in the makeup water, an inorganic precipitate routinely accumulated in the nutrient solution storage tank. On at least 2 occasions, transient excursions in effluent quality were traced to nutrient limiting conditions caused by plugging of the delivery system. Precipitation in the nutrient storage tank could be avoided by evaluating alternative ways of providing inorganic nitrogen and phosphorus, or by examining different sources of makeup water.

Of the various types of fixed-film reactors, the GAC fluid-bed reactor offers several advantages over packed-bed units. With the latter, as growth occurs the system may eventually plug as the support media becomes packed with biomass. Plugging may also result due to precipitation and accumulation of calcium carbonate or ferric iron. This problem is eliminated by operating in a fluidized-bed manner. Furthermore, the fluid-bed process provides

substantially larger surface area for biofilm growth as compared to packed-bed units, which is consistent with the fact that high treatment efficiencies can be achieved at substantially shorter residence times. Based on the results of a field study, Miller (40) reported that the reduction of chlorobenzene concentrations to below the maximum contaminant level required hydraulic residence times in the range of 20 to 70 minutes, depending on the organisms used to inoculate the packed-bed reactor. In contrast, similar treatment efficiencies were achieved in the present study at hydraulic residence times of approximately 7 minutes.

Based on the results of the present study, chlorinated aromatic hydrocarbons can be effectively treated using GAC fluid-bed bioreactors. Although for many years, chlorinated organic compounds were considered to be relatively resistant to biodegradation, recent reports suggest that many can indeed support microbial growth. In addition to mono- and dichlorinated benzenes, a number of volatile chlorinated aliphatic compounds, including methylene chloride, ethylene dichloride, vinyl chloride and 2-chloroethylvinylether have been shown to serve as carbon sources for growth (38-41). Several of these have been shown to be effectively removed in laboratory- or pilot-scale biological treatment systems (45-47). In view of the many features of commercially available GAC fluid-bed bioreactors, particularly the in-line dissolution of pure oxygen, biological treatment of groundwater or process waters containing volatile chlorinated compounds represents an attractive and cost-effective alternative to conventional technologies.

In contrast, contaminated groundwaters are also known to contain chlorinated organic compounds which do not appear to support microbial growth. Extension of this technology for treatment of such compounds will require that additional specialized biological processes be discovered and refined. Many chlorinated compounds have been shown to be aerobically biodegraded by the process of co-oxidation. In such systems, oxidation of nongrowth substrates

occurs fortuitously while the microorganisms are grown at the expense of an alternate carbon and energy source. Recent work on the development of reactor systems based on the principles of co-oxidation of chlorinated aliphatic hydrocarbons in the presence of methane or certain aromatic compounds, appears to hold some promise (48-51). Alternatively, since many chlorinated hydrocarbons are known to undergo reductive dehalogenation to lower chlorinated homologs under anaerobic conditions (52), effective treatment may be achieved by combinations of anaerobic followed by aerobic biodegradation (53).

8.0 RECOMMENDATIONS

Based on the results of the field demonstration, GAC fluid-bed bioreactors are recommended for the treatment of groundwater and process wastewaters containing a wide variety of chlorinated and nonchlorinated organic compounds capable of supporting microbial growth. The units have been shown to achieve high treatment efficiencies (> 99.99%) and reliable performance when operated according to an established operating discipline. Economic evaluation suggested that groundwater treatment costs for the bioreactor were lower as compared to several conventional water treatment technologies.

A number of improvements to the existing system were identified during the field study. Many of these are now available from the manufacturer.

- The use of self-cleaning oxygen electrodes is highly recommended to improve reliability and system performance, since provision of adequate levels of dissolved oxygen was identified as the critical operating parameter.
- Redundancy of key control devices or the addition of a remote monitoring capability would increase reliability of the system.
- Changing to the new pressurized bubble contactor design is expected to increase the organic loading capacity of the current system by 50 to 100%.
- Substitution of stainless steel for the polyvinylchloride (PVC) piping would increase the durability of the system.
- Clumping of the carbon particles should be carefully monitored during operation to insure reliable performance. The frequency of bed soundings will need to be increased for operation at high organic loadings.

- The composition of the inorganic nutrient package (urea, diammonium phosphate) should be examined when excessive precipitation occurs in the nutrient storage tank. The addition of certain micronutrients (Fe, Cu, Mn, Mo, etc) should also be considered when the water being treated is essentially devoid of inorganic ions.
- Configuration of the ladder providing access to the top of the bioreactor column could be modified for added safety and convenience.
- A switch should be added to the top of the mixer motor to facilitate bed soundings.
- Provisions should be made to minimize sudden changes in operating temperatures. In northern climates, the bioreactor should be enclosed.

ACKNOWLEDGMENTS

The authors wish to thank C. Van Metre, R. Rickerman and D. Connealy for logistical support and prestartup considerations, P. Frame for engineering and installation design, D. Jelly for addressing permit issues, M. McDonough for technical assistance, and R. Watt, M. Matz and L. Robbins for reviewing the economic analysis. We thank S. Hansen, K. Mastaw, V. Buehler, R. Hines and J. Devine of Envirex Inc., for excellent technical assistance and advice throughout the field study. We also thank J. Spain, A. Thomas and C. Vogel of the Armstrong Laboratory, Tyndall AFB, for facilitating the cooperative agreement, numerous stimulating discussions during the project, and technical review, and D. Keidel and P. Goodwin for assistance in preparing the manuscript.

9.0 REFERENCES

1. Rittman, B. E. and P. L. McCarty. 1980. Evaluation of steady-state biofilm kinetics. *Biotech. Bioeng.* 22:2359-2374.
2. Mulcahy, L. T. 1981. Simplified mathematical models for a fluidized bed biofilm reactor. *Water - 1990*, American Institute for Chemical Engineers, Symposium Series 77:273-285.
3. Bouwer, E. J. and P. L. McCarty. 1982. Removal of trace chlorinated organic compounds by activated carbon and fixed-film bacteria. *Environ. Sci. Technol.* 16:836-843.
4. Sullivan, K. M., and G. J. Skladany. 1987. Decay theory biological treatment for low-level organic contaminated groundwater and industrial waste. *Proceedings, Annual Superfund Conference*. Washington, D.C.
5. van der Hoek, L. G., Urlings, C. M., and C. M. Grobber. 1989. Biological removal of polycyclic aromatic hydrocarbons, benzene, toluene, ethylbenzene, xylene, and phenolic compounds from heavily contaminated groundwater and soil. *Environ. Tech. Lett.* 10:184-194.
6. Miller, G. P., Portier, R. J., Hoover, D. G., Friday, D. O., and J. L. Sicard. 1990. Biodegradation of chlorinated hydrocarbons in an immobilized bed reactor. *Environ. Prog.* 9:161-164.
7. Hickey, R. F., Wagner, D. and G. Mazewski. 1990. Combined biological fluid bed-carbon adsorption system for BTEX contaminated groundwater remediation. *Proceedings, Fourth National Outdoor Action Conference on Aquifer Restoration, Groundwater Monitoring and Geophysical Methods*, May 14-17, Las Vegas, NV.

8. Mueller, G. R., Sun, P. T., and G. W. Edmunds. 1990. Treatment of groundwaters containing aromatic hydrocarbons in a GAC fluidized bed biological reactor. Proceedings, American Institute of Chemical Engineers, Summer National Meeting, August 19-22, San Diego, CA.
9. Gerbasi, P. J., Smith, K. J., and J. Fillos. 1991. Biological treatment of petroleum hydrocarbons. Proceedings, National Water Well Association/American Petroleum Institute Petroleum Hydrocarbons and Organic Chemicals in Ground water Conference, November 20-22, Houston, TX.
10. Mazewski, G., Tiffany, J., and S. Hansen. 1992. Experiences with GAC-fluid bed for bioremediation of BTEX contaminated groundwaters. Proceedings, Michigan Biotechnology Institute Symposium, September 15-16, Grand Rapids, MI.
11. Hickey, R. F., Sunday, A., Wagner, D., Heine, B., Groshko, V., Hayes, T. D. and G. Mazewski. 1993. Applications of the GAC-FBR to gas industry wastestreams. Proceedings, Sixth International IGT Symposium on Gas, Oil and Environmental Biotechnology, November 29 to December 1, Colorado Springs, CO.
12. Envirex, Inc. 1994. GAC fluid bed - efficient, economical bioremediation of BTEX groundwater. Technical Bulletin ENV LTD 200-R1. Envirex, Ltd., Waukesha, WI.
13. Reineke, W., and H. J. Knackmuss. 1984. Microbial metabolism of haloaromatics: isolation and properties of a chlorobenzene-degrading bacterium. *Appl. Environ. Microbiol.* 47:395-402.
14. de Bont, J. A. M., Vorage, M. J. A. W., Hartmans, S., and W. J. J. van den Tweel. 1986. Microbial degradation of 1,2-dichlorobenzene. *Appl. Environ. Microbiol.* 52:677-680.

15. Schraa, G., Boone, M. L., Jetten, M. S. M., Van Neerven, A. R. W., Colberg, P. J. and A. J. B. Zehnder. 1986. Degradation of 1,4-dichlorobenzene by Alcaligenes sp. strain A-175. Appl. Environ. Microbiol. 52:1374-1381.
16. Spain, J. C., and S. F. Nishino. 1987. Degradation of 1,4-dichlorobenzene by a Pseudomonas sp. Appl. Environ. Microbiol. 53:1010-1019.
17. Haigler, B. E., Nishino, S. F., and J. C. Spain. Degradation of 1,2-dichlorobenzene by a Pseudomonas sp. Appl. Environ. Microbiol. 54:294-301.
18. Nishino, S. F., Spain, J. C., Belcher, L. A., and C. D. Litchfield. 1992. Chlorobenzene degradation by bacteria isolated from contaminated groundwater. Appl. Environ. Microbiol. 58:1719-1726.
19. Haigler, B. F., Pettigrew, C. A., and J. C. Spain. 1992. Biodegradation of mixtures of substituted benzenes by Pseudomonas sp. strain JS150. Appl. Environ. Microbiol. 58:2237-2244.
20. Pettigrew, C. A., Spain, J. C., and C. M. Vogel. 1993. Biological treatment of groundwater contaminated with mixtures of aromatic compounds. Final report ESL TR-91-42. Air Force Civil Engineering Support Agency, Tyndall Air Force Base, FL.
21. Nishino, S. F., Spain, J. C., and C. A. Pettigrew. 1994. Biodegradation of chlorobenzene by indigenous bacteria. Environ. Toxicol. Chem. 13:871-877.
22. Hansen, S. 1994. Personal communication. Envirex Inc., Waukesha, WI.

23. Envirex, Inc. 1993. GAC fluid bed operating manual. Envirex, Inc., Waukesha, WI.
24. Metcalf and Eddy, Inc. 1979. Wastewater engineering: treatment, disposal, reuse. McGraw-Hill Book Co., New York, NY.
25. Stanier, R. Y., Palleroni, N. J., and M. Doudoroff. 1966. The aerobic pseudomonads: a taxonomic study. *J. Gen. Microbiol.* 43:159-271.
26. Claus, D., and N. Walker. 1964. The decomposition of toluene by soil bacteria. *J. Gen. Microbiol.* 36:107-122.
27. Mastaw, K. 1993. Personal communication. Envirex Inc., Waukesha, WI.
28. Bureau of National Affairs, Inc. 1992. Method 21 - determination of volatile organic compounds leaks. Bureau of National Affairs, Part 60, Appendix A, Method 21, Washington D.C.
29. Orion Research, Inc. 1978. Analytical methods guide. Orion Research, Inc., Cambridge, MA.
30. U.S. Environmental Protection Agency. 1979. Methods for chemical analysis of water and wastes, EPA-600/4-79-020, method 365.2. U.S. Environmental Protection Agency, Washington, D.C.
31. American Public Health Association. 1985. Standard methods for examination of water and wastewater, 16th ed. American Public Health Association, Washington, D.C.
32. Dobbs, R. A., and J. M. Cohen. 1980. Carbon adsorption isotherms for toxic organics, EPA-600/8-80-023. U.S. Environmental Protection Agency, Washington, D.C.

33. Hohl, H. 1994. Personal communication, Celgene Corp., Warren, NJ.
34. Stotka, L. 1995. Personal communication, Calgon Carbon Corp., Pittsburgh, PA.
35. Reid, R. C., Prausnitz, J. M., and B. E. Poling. 1987. The properties of gases and liquids, 4th edition. McGraw-Hill Book Co., New York, NY.
36. Treybal, R. E. 1980. Mass-transfer operations, 3rd edition. McGraw-Hill Book Co., New York, NY.
37. Evans, G. 1990. Estimating innovative technology costs for the SITE program. J. Air Waste Mgmt. Assoc.
38. Brunner, W., Staub, D., and T. Leisinger. 1980. Bacterial degradation of dichloromethane. Appl. Environ. Microbiol. 40:950-958.
39. Stucki, G., Krebsler, U., and T. Leisinger. 1983. Bacterial growth on 1,2-dichloroethane. Experientia 39:1271-1273.
40. Hartman, S., de Bont, J. A. M., Tramper, J., and K. C. A. M. Luyben. 1985. Bacterial degradation of vinyl chloride. Biotechnol. Lett. 7:383-388.
41. van den Winjgaard, A. J., Prins, J., Smal, A. J. A. C., and D. B. Janssen. 1993. Degradation of 2-chloroethylvinylether by Acylobacter aquaticus AD25 and AD27. Appl. Environ. Microbiol. 59:2777-2783.
42. McSherry, M. P., Davis, G. M. and R. J. Falco. 1992. Measurement of VOC emissions from wastewater treatability units.

Proceedings 85th Annual Meeting and Exhibition, Air and Waste Management Association, June 21-26, Kansas City, MO.

43. Eckel, J. A., Falco, R. J., and G. Mazewski. 1994. Groundwater treatment. *Indust. Wastewater* 2:24-29.
44. Miller, D.E. 1994. Chlorobenzene bioreactor demonstration project. Draft report. Air Force Civil Engineering Support Agency, Tyndall Air Force Base, FL.
45. Galli, R. 1987. Biodegradation of dichloromethane in wastewater using a fluidized bed bioreactor. *Appl. Microbiol. Biotechnol.* 27:206-213.
46. Stucki, G., Thuer, M. and R. Bentz. 1992. Biological degradation of 1,2-dichloroethane under groundwater conditions. *Wat. Res.* 26:273-278.
47. Gruber, W. 1993. Celgene's biotreatment technology. *El Digest*, November, pp. 17-20.
48. Phelps, T. J., Niedzielski, J. J., Schram, R. M., Herbes, S. E., and D. C. White. 1990. Biodegradation of trichloroethylene in continuous-recycle expanded-bed bioreactors. *Appl. Environ. Microbiol.* 56:1702-1709.
49. McFarland, M. J., Vogel, C. M., and J. C. Spain. 1992. Methanotrophic cometabolism of trichloroethylene (TCE) in a two stage bioreactor system. *Wat. Res.* 26:259-265.
50. Folsom, B. R., and P. J. Chapman. 1991. Performance characteristics of a model bioreactor for biodegradation of trichloroethylene by *Pseudomonas cepacia* G4. *Appl. Environ. Microbiol.* 57:1602-1608.

51. Folsom, B. 1993. Liquid-phase bioreactor for degradation of trichloroethylene and benzene. Final report ESL-TR-92-02. Air Force Civil Engineering Support Agency, Tyndall Air Force Base, FL.
52. Vogel, T. M., Criddle, C. S., and P. L. McCarty. 1987. Transformations of halogenated aliphatic compounds. *Environ. Sci. Technol.* 21:722-736.
53. Fathepure, B. Z., and T. M. Vogel. 1991. Complete degradation of polychlorinated hydrocarbons by a two-stage biofilm reactor. *Appl. Environ. Microbiol.* 57:3418-3422.

APPENDIX A

Summary of Operating Parameters Recorded During the Field Study

LAPORTE DEMONSTRATION - OPERATING DATA FOR ENVIREX GAC-BIOREACTOR

DAY	DATE	TIME	IN FLOW GPM	RC FLOW GPM	IN D.O. PPM	EF D.O. PPM	O2 FLOW CFH	BED FT	HT FT	FD MCB PPM	IN MCB PPM	EF MCB PPM	EF MCB PPB	IN pH	EF pH	EF TEMP C	EF NH3 PPM	EF PO4 PPM	EF TSS PPM	EF VSS PPM	
0	06-28-93																				
1	06-29-93																				
2	06-30-93																				
3	07-01-93	9:00	2.0	30.0	NA	NA		7.0		113.3	9.2	ND		8.03							
3	07-01-93	14:00	2.0							113.3	11.4	ND									
4	07-02-93	9:00	0.8	29.5	7.2	1.5	0.4	7.0		113.3	5.5	ND		7.11	7.23						
4	07-02-93	11:00	2.0							113.3											
4	07-02-93	15:00								113.3											
4	07-02-93	17:00	1.8	29.8	2.9	2.3	0.1			113.3				7.04	7.11	33.1					
5	07-03-93	18:30	1.8	28.6	6.4	2.8	0.5			113.3				7.04	7.25	33.6					
6	07-04-93	11:50	1.7	24.9	16.7	3.9	0.7			113.3				6.85	6.98	32.3					
7	07-05-93	20:00	2.1	29.6	12.4	2.3	0.8			113.3				5.96	6.38	31.2					
8	07-06-93	9:00	2.1	30.0	10.5	2.8	0.6	7.5		118.3	12.9	ND		6.27	6.83	29.9					
8	07-06-93	13:00	2.0	27.3	17.1	3.1	1.0			118.3				6.39	6.27	28.0					
8	07-06-93	17:00	1.9	27.1	20.8	3.6	1.2			118.3	10.6	ND		6.30	6.17	31.9					
9	07-07-93	8:00	2.0	27.0	26.0	4.7	1.5			118.3	8.7	ND		6.82	6.35	33.0					
9	07-07-93	10:00	1.0					8.3		118.3				6.34	5.94	28.6					
9	07-07-93	18:00	1.0	27.2	18.6	1.9	1.2			118.3				6.29	5.90	32.9					
10	07-08-93	8:00	1.0	27.8	13.0	2.9	0.7	8.3		118.3				6.69	6.75	29.4					
10	07-08-93	13:00	0.8	27.7	11.5	2.5	0.7			118.3	3.0	ND		6.69	6.62	34.1					
10	07-08-93	17:00	1.1	27.5	13.1	1.6	1.0			118.3				6.65	6.56	34.9					
11	07-09-93	7:30	1.2	27.7	13.2	2.5	0.8	8.0		167.3	2.8	ND		6.59	6.53	28.1					
11	07-09-93	12:30	1.1	30.1			0.0			167.3				6.68	6.60	33.6					
11	07-09-93	15:12	1.1	28.6	1.1	4.2	0.7			167.3				6.63	6.55	34.3					
11	07-09-93	21:00								167.3											
12	07-10-93									167.3											
13	07-11-93	9:00	1.0	30.2	17.2	15.2	0.0			167.3				6.61	6.90	28.8					
13	07-11-93	11:30	1.0	27.5	14.0	2.0	0.8			167.3				6.64	6.89	31.6					
13	07-11-93	13:00	1.1	27.5	14.8	2.5	0.8		7.5	167.3				6.40	6.89	32.9					
13	07-11-93	17:30	1.1	27.5	14.8	2.7	0.8			167.3				6.24	6.89	33.4					
14	07-12-93	7:30	1.1	27.6	14.1	2.0	0.8	7.3		167.3				6.04	6.79	28.0					
14	07-12-93	9:15	2.0	28.1	19.4	3.2	1.1			145.8	4.9	ND		6.32	5.95						
14	07-12-93	13:30					1.3														
15	07-13-93	9:00	2.0	27.6	37.3	6.8	2.5	7.3		131.0	6.2	ND		6.20	6.35	28.2					
15	07-13-93	18:00	1.9	28.1	21.1	1.8	1.5			131.0				5.98	6.85	32.4					
16	07-14-93	9:00	2.0	27.1	23.3	3.2	1.3	7.3		131.0	4.5	ND		5.82	6.86	29.2					
17	07-15-93	7:50	1.9	27.1	21.0	3.0	1.2			141.2	6.3	ND		5.76	6.86	28.5					
18	07-16-93	8:00	1.8	31.8	15.6	3.1	1.3			141.2				5.71	6.86	27.9					
18	07-16-93	13:30	2.0	27.5	32.8	0.4	3.3	7.3		141.2	3.4	ND		6.13	6.88	31.6					
18	07-16-93	16:00	2.0	27.9	20.5	3.3	1.1	7.3		141.2	3.4	ND		6.05	6.88	30.8					
19	07-17-93	9:30	1.9	27.3	22.0	3.5	1.3			141.2				5.90	6.89						
20	07-18-93									141.2											
21	07-19-93	10:45	2.0	27.2	18.4	3.3	1.3	7.3		137.4	12.2	ND		5.86	6.89	29.4					
21	07-19-93	14:00	2.9	27.8	24.1	0.7	2.5			137.4				5.85	6.88	32.4					
21	07-19-93	18:30	2.9	27.2	23.1	2.1	2.0			137.4				5.86	6.88	32.0					

DL = 0.5 DL = 5

LAPORTE DEMONSTRATION - OPERATING DATA FOR ENVIREX GAC-BIOREACTOR

DAY	DATE	TIME	IN FLOW GPM	RC FLOW GPM	IN D.O. PPM	EF D.O. PPM	O2 PPM	CFH	BED FT	HT FT	FD PPM	MCB IN PPM	EF MCB PPM	MCB PPB	IN pH	EF pH	C	TEMP	EF NH3 PPM	PO4 PPM	TSS PPM	EF VSS PPM	
22	07-20-93	7:30	3.0	26.8	24.3	2.1	1.9	7.3	120.5	13.2	ND	5.91	6.89	27.4	5.88	6.88	30.7	6.8	2.2	28.0			
22	07-20-93	13:30	3.0	26.6	28.2	2.3	2.0	7.3	120.5	14.3	ND	5.92	6.89	26.4	5.86	6.88	31.4						
23	07-21-93	7:53	3.2	26.6	29.4	1.7	2.0	7.3	128.1	14.3	ND	5.84	6.88	30.9	5.84	6.89	28.3						
23	07-21-93	13:00	2.8	28.0	28.7	0.7	2.2		128.1			5.84	6.88	30.9	5.84	6.89	28.3						
23	07-21-93	18:30	2.9	27.1	30.4	3.1	2.0		128.1			5.84	6.89	28.3	5.84	6.89	28.3						
24	07-22-93	7:30	3.1	27.1	31.7	3.2	2.0	7.3	120.2	13.6	ND	6.13	6.87	31.9	6.17	6.88							
25	07-23-93	7:30	3.2	26.9	27.8	2.8	2.1	7.5	134.7	13.8	ND												
25	07-23-93	16:00	2.9	27.0	24.6	2.4	2.4		134.7														
26	07-24-93	9:40	2.9	26.9	26.1	2.5	1.9		134.7														
26	07-24-93	16:00	2.9	26.9	24.0	2.6	2.0		134.7														
27	07-25-93	7:30	2.9	26.9	23.3	2.2	2.1		134.7														
27	07-25-93	15:00	2.9	26.9	24.0	2.3	2.0		134.7														
28	07-26-93	7:30	2.9	26.9	19.0	2.0	2.1	7.5	132.2	10.8	ND	6.05	6.88	26.3	6.12	6.88							
29	07-27-93	7:20	2.9	26.9	18.1	3.9	2.1	7.5	139.8	12.2	ND	<10;	11.5	6.01	6.88	27.7	5.8	2.3	26.0				
30	07-28-93	7:42	2.8	26.8	18.4	1.6	2.0	7.5	123.6	10.3	ND	< 5		6.05	6.88	27.1							
31	07-29-93	7:11	2.7	27.0	23.4	2.6	1.9	7.5	141.5	13.0	ND	6.00	6.88	27.6	6.00	6.88							
32	07-30-93	14:02	2.6	27.1	20.1	2.5	2.1	7.5	111.5	7.7	ND	< 5		6.03	6.87	31.9							
33	07-31-93	10:44	2.6	26.9	21.5	2.6	1.9		111.5														
34	08-01-93	8:48	2.7	26.7	24.0	3.2	2.2		111.5														
35	08-02-93		2.6	26.6	21.5	2.2	2.1	8.0	117.5	11.0	ND	<10;	13.0	5.97	6.87	30.6							
36	08-03-93		2.7	27.1	22.8	5.7	1.2	8.0	129.0	11.4	ND	6.15	6.85	27.1	6.18	6.85	26.8	0.1	0.2	18.0	11.0		
37	08-04-93	8:20	3.0	27.7	27.6	2.9	2.1	8.5	110.0	12.8	ND	12.0		6.13	6.85	27.1							
38	08-05-93	8:33	2.9	26.6	27.1	2.8	2.0	8.5	123.1	13.3	ND	32.5		6.13	6.85	27.8							
39	08-06-93	8:21	2.8	26.3	27.6	2.2	1.8	8.5	109.4	10.8	ND			6.15	6.84								
40	08-07-93	9:00	2.8	26.3	25.7	1.9	2.2		109.4					6.11	6.84								
41	08-08-93	11:00	2.6	26.3	27.3	4.2	2.2		109.4					6.10	6.85	28.8							
42	08-09-93	7:46	2.6	25.8	24.8	2.2	1.8	9.0	104.8	10.4	ND	<10 ; <5		6.13	6.85	27.4							
43	08-10-93	7:45	2.7	25.5	21.8	1.8	1.8	9.0	123.4	11.4	ND												
43	08-10-93	9:00	4.0																				
44	08-11-93	13:00	4.1	24.8	32.7	4.7	3.4	8.8	117.1	10.3	ND	< 5		6.14	6.84	31.4	8.3	2.9	18.0	11.0			
45	08-12-93	9:30	4.0	25.7	35.3	4.2	3.2	9.0	138.6	16.6	ND			6.14	6.85	27.8							
46	08-13-93	8:00	3.9	25.8	30.9	2.5	2.6	9.0	129.3	16.3	ND	< 5		6.10	6.85	28.3							
47	08-14-93																						
48	08-15-93	9:11	3.8	26.5	26.7	2.3	2.8							6.08	6.85								
49	08-16-93	6:30	3.8	26.3	23.1	2.9	2.3	10.0	116.7	15.8	ND	<10 ; <5		6.14	6.85	26.5							
50	08-17-93	8:30	4.0	28.2	29.6	2.8	2.5	10.3	120.1	17.4	ND			6.06	6.85	28.4							
51	08-18-93	7:00	4.0	28.1	25.4	2.9	2.7	10.5	145.2	22.1	ND	< 5		6.07	6.85	26.5	3.5	1.5	21.0	13.0			
52	08-19-93	6:45	4.0	27.1	27.6	2.7	2.9	10.5	150.2	17.9	ND			6.05	6.85	26.4							
53	08-20-93	7:40	4.0	27.6	30.0	2.0	2.9	11.0	106.0	20.4	ND	< 5		6.04	6.85	26.7							
54	08-21-93																						
55	08-22-93																						
56	08-23-93	8:10	4.0	27.3	28.9	2.6	2.9	10.5	139.7	17.3	ND	<10 ; <5		6.08	6.85	27.3							
57	08-24-93	7:19	4.0	28.4	32.6	2.6	3.3	10.5	143.2	17.8	ND			6.02	6.85	29.1							

LAPORTE DEMONSTRATION - OPERATING DATA FOR ENVIREX GAC-BIOREACTOR

DAY	DATE	TIME	IN FLOW RC	FLOW	IN D.O.	EF D.O.	O2 FLOW	BED	HT	FD	MCB	IN MCB	EF MCB	EF MCB	IN pH	EF pH	EF TEMP	EF NH3	EF PO4	EF TSS	EF VSS
			GPM	GPM	PPM	PPM	CFH	FT	PPM	PPM	PPM	PPM	PPM	PPB			C	PPM	PPM	PPM	PPM
58	08-25-93	7:11	4.0	28.7	25.0	2.2	2.5	10.5	113.9	14.1	ND	ND	< 5	6.09	6.85	26.7	2.1	1.0	33.0	25.0	
59	08-26-93	7:07	4.0	28.2	27.9	2.3	2.7	10.5	126.7	20.5	ND	ND	< 5	6.04	6.85	28.0					
60	08-27-93	7:11	4.0	28.2	27.9	2.8	2.7	11.0	121.2	20.9	ND	ND	< 5	6.11	6.85	26.6					
61	08-28-93																				
62	08-29-93																				
63	08-30-93	8:05	4.0	28.7	29.4	3.6	2.6	11.0	115.2	18.0	ND	ND		6.10	6.85	26.3	6.1	1.1	34.0	31.0	
																					(ABOVE DATA ACTUALLY FROM 8-3)
65	09-01-93	8:30	4.0	28.8	28.6	2.2	2.7	10.6	108.6	19.3	ND	ND	9.5	6.07	6.85	29.6					
66	09-02-93	8:30	4.0	28.5	30.4	2.4	3.3	10.7	121.5	20.9	ND	ND		6.03	6.85	28.1					
67	09-03-93	7:30	4.0	28.6	30.5	2.6	3.2	11.0	132.1	21.4	ND	ND	7.5	6.06	6.85	26.0					
68	09-04-93																				
69	09-05-93																				
70	09-06-93																				
71	09-07-93	8:00	4.0	28.3	24.8	2.6	2.7	11.0	105.5	18.5	ND	ND	3.0, 39.0	6.08	6.85	26.9	3.9	1.2	17.0	5.0	
72	09-08-93	8:00	4.0	28.5	22.2	2.6	2.5	11.0	115.3	18.0	ND	ND	<10	6.09	6.85	25.8					
73	09-09-93	7:45	4.0	28.5	25.1	2.4	3.1	11.0	134.6	17.6	ND	ND		6.04	6.85	26.6					
74	09-10-93	7:50	4.0	29.0	31.5	4.2	3.2	11.0	129.2	19.7	ND	ND	< 5	6.03	6.85	27.0					
75	09-11-93																				
76	09-12-93																				
77	09-13-93	8:05	4.0	29.3	38.3	5.1	2.8	11.0	144.3	19.5	ND	ND	7.0	6.02	6.85	27.2	1.7	1.1	35.0	26.0	
78	09-14-93	8:00																			
78	09-14-93	8:15	4.0	29.8	42.1	0.0	4.0	11.0	129.3	2.1	ND	ND		6.01	6.85	28.4					
79	09-15-93	8:25	4.0	30.4	25.1	0.2	2.1	11.0	155.1	18.9	*NQ	532.0		6.14	6.85	21.4					
80	09-16-93	8:46	3.8	29.2	35.0	3.5	2.1	11.0	118.3	19.7	ND	ND		6.09	6.85	22.1					
81	09-17-93	7:04	3.6	29.1	35.0	2.9	2.1	11.0	120.4	17.6	ND	ND	260.0	6.08	6.86	23.3					
82	09-18-93																				
83	09-19-93																				
84	09-20-93	8:30	3.7	27.8	42.4	2.8	3.2	11.0	117.5	16.1	ND	ND		6.02	6.85	27.6					
85	09-21-93	9:30	4.0	28.4	26.9	1.8	2.5	11.0	131.1	20.0	ND	ND	83.5	6.05	6.85	26.5	2.2	1.9	49.0	39.0	
86	09-22-93	6:45	4.0	28.2	32.5	2.1	3.1	10.5	141.4	19.7	ND	ND	< 5	6.01	6.85	26.9					
87	09-23-93	7:40	4.0	28.6	0.2	2.3	2.4	10.0	113.2	17.6	ND	ND		6.05	6.85	27.4					
87	09-23-93																				
88	09-24-93	15:00	4.0	29.1	33.8	2.6	3.1	10.0	127.5	17.9	ND	ND	7.0	5.99	6.84	31.3					
89	09-25-93																				
90	09-26-93																				
91	09-27-93	8:35	4.0	29.2	37.6	1.9	3.1	11.0	138.5	18.1	ND	ND	< 5	6.02	6.86	24.7					
92	09-28-93	8:30	4.0	29.4	30.8	2.1	2.4	11.0	127.5	19.4	ND	ND	26.5	6.07	6.86	22.9	0.6	2.4			
92	09-28-93	14:40	5.0	29.5	34.5	2.7	3.6	11.0	150.5	22.0	ND	ND	< 5	6.03	6.85	28.4					
93	09-29-93	8:30	4.9	29.4	36.5	1.2	3.8	11.0	181.5	24.6	ND	ND	104.5	6.06	6.86	23.3					
94	09-30-93	8:50	4.9	29.9	33.4	1.3	3.8	11.0	168.5	29.0	ND	ND	314.0	6.04	6.86	24.2					
95	10-01-93	12:00	5.0	30.0	30.4	1.2	3.9	11.0	151.9	20.3	ND	ND	146.5	6.02	6.85	29.5					
96	10-02-93																				
97	10-03-93																				
98	10-04-93	9:30	5.0	30.0	28.2	0.2	3.9	10.0	188.8	29.2	1.4	1364.0		6.03	6.86	24.4	1.1	2.3	56.0	52.0	
98	10-04-93																				

LAPORTE DEMONSTRATION - OPERATING DATA FOR ENVIREX GAC-BIOREACTOR

DAY	DATE	TIME	IN FLOW GPM	RC FLOW GPM	IN D.O. PPM	EF D.O. PPM	O2 FLOW CFH	BED HT FT	HT FD PPM	IN MCB PPM	EF MCB PPM	EF MCB PPB	IN pH	EF pH	EF TEMP C	EF NH3 PPM	EF PO4 PPM	EF TSS PPM	EF VSS PPM		
174	12-19-93																				
175	12-20-93	12:30	1.5	33.8	14.1	2.6	0.7	8.0	84.6	3.1	ND	5.5	6.36	6.88	20.8	5.7	2.6	22.0			
176	12-21-93	14:30	1.8	33.8	14.4	2.1	0.7	8.0	106.2	4.6	ND	7.0	6.34	6.88	19.1						
177	12-22-93	10:00	1.7	34.6	14.8	3.2	0.6	8.3	104.6	4.7	ND		6.42	6.88	15.8						
178	12-23-93								116.6	7.0	ND										
179	12-24-93																				
180	12-25-93	14:40																			
181	12-26-93																				
182	12-27-93	8:30	1.5						132.5	3.9	ND	< 5									
183	12-28-93																				
184	12-29-93																				
185	12-30-93	13:30	2.0	33.0	14.0	2.0	1.0	8.0	121.2	5.6	ND					6.4		25.0			
186	12-31-93																				
187	01-01-94																				
188	01-02-94																				
189	01-03-94	9:00	2.0	34.3	16.8	3.2	1.9	9.5	131.8	7.4	ND	9.5	6.06	6.45	18.8	2.2	2.3	24.0			
190	01-04-94	13:30	2.0	34.2	15.6	4.0	1.9						6.07	6.44	20.7						
191	01-05-94	8:01	2.1	34.9	20.3	6.3	1.8		122.1	6.8	ND		6.60	6.45	18.0						
192	01-06-94	7:50	1.9	33.3	18.2	2.3	1.9		106.2		ND		6.11	7.15	22.1						
193	01-07-94	8:00	1.9	36.6	14.3	4.5	1.9		118.3		ND		6.12	7.17	18.7						
194	01-08-94																				
195	01-09-94																				
196	01-10-94	9:15	1.9	37.2	9.1	4.1	1.5	9.5	101.3		ND		6.34	7.17	18.3						
197	01-11-94	9:30	1.9	33.7	19.2	3.1	2.0	9.5	116.1	7.7	ND	< 5	6.27	7.16	21.0	3.1	2.7	15.0	12.0		
198	01-12-94	15:30	2.5	32.8	22.4	2.0	2.6	10.0	119.3	10.0	ND		6.06	7.17	19.8						
199	01-13-94	15:00	2.6	31.1	28.8	6.5	2.3	10.0	116.7	12.2	ND	23.0	6.06	7.19	21.3						
200	01-14-94	15:00	2.5	31.7	19.5	2.4	1.9	10.5	110.4	8.3	ND		6.12	7.15	23.8						
201	01-15-94																				
202	01-16-94																				
203	01-17-94	10:30	2.5	31.6	25.8	3.1	2.8	11.0	112.8	10.5	ND	17.0	6.04	7.17	18.6	1.9	2.7	81.0			
204	01-18-94	14:00	2.5	35.5	19.2	14.0	2.0	11.0					6.65	7.19							
204	01-18-94																				
205	01-19-94																				
206	01-20-94	14:30	2.5	32.5	16.4	3.9	1.1	10.5	117.5	7.5	ND	152.0	6.39	7.17	17.7						
206	01-20-94																				
207	01-21-94	14:30	2.5	32.3	18.7	3.1	1.2	10.5	103.9	9.0	ND	7.0	6.16	7.16	21.0						
208	01-22-94																				
209	01-23-94																				
210	01-24-94	14:30	2.5	35.7	24.1	0.7	0.9	11.0	110.6	8.2	ND	21.0	6.06	7.15	22.7	3.0	4.0				
210	01-24-94																				
211	01-25-94	15:00	3.0	30.1	24.9	4.2	1.6	11.5	107.8	12.4	ND		6.12	7.14	25.4						
211	01-25-94																				
212	01-26-94	13:00	3.0	30.1	23.8	4.0	1.4	11.0	104.2	11.8	ND	< 5	6.11	7.15	24.5						
213	01-27-94	13:30	3.0	31.0	24.6	3.8	1.3	11.0	91.8	7.1	ND		6.10	7.15	23.5						

LAPORTE DEMONSTRATION - CALCULATED OPERATING PARAMETERS

DAY	IN FLOW GPM	TOD LOAD #/DAY	LOAD CAPACITY #/DAY	MEAS IN MCB PPM	CALC IN MCB PPM	MEAS IN TOD PPM	PROBE DLT D.O. PPM	O2 APPLIED #/DAY	PROBE DO MEAS TOD % DO/TOD	TREAT EFFIC % OF FD
0										
1										
2										
3	2.0	5.4	10.0	9.2	7.6	18.4				> 99.5
3	2.0	5.4	10.0	11.4		22.8				> 99.5
4	0.8	2.2	10.0	5.5	3.1	11.0	5.7	2.0	51.8	> 99.5
4	2.0	5.4	10.0							
4			10.0							
4	1.8	4.9	10.0		6.8		0.6	0.2		
5	1.8	4.9	10.0		7.1		3.6	1.2		
6	1.7	4.6	10.0		7.7		12.8	3.8		
7	2.1	5.7	10.0		8.0		10.1	3.6		
8	2.1	6.0	10.0	12.9	8.3	25.8	7.7	2.8	29.8	> 99.5
8	2.0	5.7	10.0		8.7		14.0	4.6		
8	1.9	5.4	10.0	10.6	8.3	21.2	17.2	5.6	81.1	> 99.5
9	2.0	5.7	10.0	8.7	8.8	17.4	21.3	6.9	122.4	> 99.5
9	1.0	2.8	10.0							
9	1.0	2.8	10.0		4.3		16.7	5.5		
10	1.0	2.8	10.0		4.3		10.1	3.4		
10	0.8	2.3	10.0	3.0	3.4	6.0	9.0	3.0	150.0	> 99.5
10	1.1	3.1	10.0		4.7		11.5	3.8		
11	1.2	4.8	10.0	2.8	7.2	5.6	10.7	3.6	191.1	> 99.5
11	1.1	4.4	10.0		6.1					
11	1.1	4.4	10.0		6.4					
11			10.0							
12			10.0							
13	1.0	4.0	10.0		5.5		2.0	0.7		
13	1.0	4.0	10.0		6.1		12.0	4.0		
13	1.1	4.4	10.0		6.7		12.3	4.1		
13	1.1	4.4	10.0		6.7		12.1	4.0		
14	1.1	4.4	10.0		6.7		12.1	4.0		
14	2.0	7.0	10.0	4.9	10.4	9.8	16.2	5.5	165.3	> 99.5
14			10.0							
15	2.0	6.3	10.0	6.2	9.5	12.4	30.5	10.1	246.0	> 99.5
15	1.9	6.0	10.0		8.9		19.3	6.5		
16	2.0	6.3	10.0	4.5	9.7	9.0	20.1	6.5	223.3	> 99.5
17	1.9	6.4	10.0	6.3	9.9	12.6	18.0	5.9	142.9	> 99.5
18	1.8	6.1	10.0		8.0		12.5	4.8		
18	2.0	6.8	10.0	3.4	10.3	6.8	32.4	10.7	476.5	> 99.5
18	2.0	6.8	10.0	3.4	10.1	6.8	17.2	5.8	252.9	> 99.5
19	1.9	6.4	10.0		9.8		18.5	6.1		
20			10.0							
21	2.0	6.6	10.0	12.2	10.1	24.4	15.1	4.9	61.9	> 99.5
21			10.0							
21	2.9	9.6	10.0		14.3		23.4	7.8		
21	2.9	9.6	10.0		14.6		21.0	6.9		

LAFORTE DEMONSTRATION - CALCULATED OPERATING PARAMETERS

DAY	IN FLOW GPM	TOD LOAD #/DAY	CAPACITY #/DAY	MEAS IN MCB PPM	CALC IN MCB PPM	MEAS IN TOD PPM	PROBE DLT D.O. PPM	O2 APPLIED #/DAY	PROBE DO MEAS TOD % DO/TOD	TREAT EFFIC % OF FD
22	3.0	8.7	10.0	13.2	13.5	26.4	22.2	7.1	84.1	> 99.5
22	3.0	8.7	10.0	13.6	13.6	25.9	25.9	8.3	96.9	> 99.5
23	3.2	9.8	10.0	14.3	15.4	28.6	27.7	8.8		
23	2.8	8.6	10.0	12.8	12.8		28.0	9.4		
23	2.9	8.9	10.0	13.7	13.7	27.3	27.3	8.9		
24	3.1	8.9	10.0	13.6	13.7	27.2	28.5	9.3	104.8	> 99.5
25	3.2	10.3	10.0	13.8	16.0	27.6	25.0	8.1	90.6	> 99.99
25	2.9	9.4	10.0	14.5	14.5	22.2	22.2	7.2		
26	2.9	9.4	10.0	14.5	14.5	23.6	23.6	7.6		
26	2.9	9.4	10.0	14.5	14.5	21.4	21.4	6.9		
27	2.9	9.4	10.0	14.5	14.5	21.1	21.1	6.8		
27	2.9	9.4	10.0	14.5	14.5	21.7	21.7	7.0		
28	2.9	9.2	10.0	10.8	14.3	21.6	17.0	5.5	78.7	> 99.5
29	2.9	9.7	10.0	12.2	15.1	24.4	14.2	4.6	58.2	> 99.99
30	2.8	8.3	10.0	10.3	12.9	20.6	16.8	5.4	81.6	> 99.99
31	2.7	9.2	10.0	13.0	14.2	26.0	20.8	6.7	80.0	> 99.5
32	2.6	7.0	10.0	7.7	10.7	15.4	17.6	5.7	114.3	> 99.99
33	2.6	7.0	10.0	10.8	10.8	18.9	18.9	6.1		
34	2.7	7.2	10.0	11.3	11.3	20.8	20.8	6.7		
35	2.6	7.3	10.0	11.0	11.5	22.0	19.3	6.2	87.7	> 99.99
36	2.7	8.4	10.0	11.4	12.9	22.8	17.1	5.6	75.0	> 99.5
37	3.0	7.9	10.0	12.8	11.9	25.6	24.7	8.2	96.5	99.989
38	2.9	8.6	10.0	13.3	13.4	26.6	24.3	7.8	91.4	> 99.5
39	2.8	7.4	10.0	10.8	11.6	21.6	25.4	8.0	117.6	99.970
40	2.8	7.4	10.0	10.8	11.6	23.8	23.8	7.5		
41	2.6	6.8	10.0	10.4	10.8	23.1	23.1	7.3		
42	2.6	6.5	10.0	10.4	10.6	20.8	22.6	7.0	108.7	> 99.99
43	2.7	8.0	10.0	11.4	13.1	22.8	20.0	6.1	87.7	> 99.5
43	4.0	10.0	10.0	10.3	19.4	20.6	28.0	8.3	135.9	> 99.99
44	4.1	11.5	10.0	16.6	21.6	33.2	31.1	9.6	93.7	
45	4.0	13.3	10.0	16.3	19.5	32.6	28.4	8.8	87.1	> 99.99
46	3.9	12.1	10.0	15.8	16.9	31.6	20.2	6.4	63.9	> 99.99
47	3.8	10.6	10.0	17.4	17.0	34.8	26.8	9.1	77.0	> 99.5
48	3.8	11.5	10.0	22.1	20.7	44.2	22.5	7.6	50.9	> 99.99
49	4.0	13.9	10.0	17.9	22.2	35.8	24.9	8.1	69.6	> 99.5
50	4.0	14.4	10.0	20.4	15.4	40.8	28.0	9.3	68.6	> 99.99
51	4.0	10.2	10.0	17.3	20.5	34.6	26.3	8.6	76.0	> 99.99
52	4.0	13.4	10.0	17.8	20.2	35.6	30.0	10.2	84.3	> 99.5
53	4.0	13.7	10.0							
54										
55										
56	4.0	13.4	10.0	17.3	20.5	34.6	26.3	8.6	76.0	> 99.99
57	4.0	13.7	10.0	17.8	20.2	35.6	30.0	10.2	84.3	> 99.5

LAVORTE DEMONSTRATION - CALCULATED OPERATING PARAMETERS

DAY	IN FLOW		TOD LOAD		LOAD CAPACITY		MEAS IN MCB		CALC IN MCB		MEAS IN TOD		DLT D.O.		APPLIED		PROBE DO		TREAT EFFIC		
	GPM	#/DAY	#/DAY	#/DAY	#/DAY	#/DAY	PPM	PPM	PPM	PPM	PPM	PPM	PPM	%	%	%	%	%	%	%	
58	4.0	10.9	10.0	10.0	14.1	15.9	28.2	22.8	7.9	80.9	> 99.99										
59	4.0	12.2	10.0	10.0	20.5	18.0	41.0	25.6	8.7	62.4	> 99.5										
60	4.0	11.6	10.0	10.0	20.9	17.2	41.8	25.1	8.5	60.0	> 99.99										
61			10.0																		
62			10.0																		
63	4.0	11.1	10.0	10.0	18.0	16.1	36.0	25.8	8.9	71.7	> 99.5										
65	4.0	10.4	10.0	10.0	19.3	15.1	38.6	26.4	9.1	68.4	99.991										
66	4.0	11.7	10.0	10.0	20.9	17.1	41.8	28.0	9.6	67.0	> 99.5										
67	4.0	12.7	10.0	10.0	21.4	18.5	42.8	27.9	9.6	65.2	99.994										
68			10.0																		
69			10.0																		
70			10.0																		
71	4.0	10.1	10.0	10.0	18.5	14.9	37.0	22.2	7.5	60.0	> 99.99										
72	4.0	11.1	10.0	10.0	18.0	16.2	36.0	19.6	6.7	54.4	> 99.99										
73	4.0	12.9	10.0	10.0	17.6	18.9	35.2	22.7	7.8	64.5	> 99.5										
74	4.0	12.4	10.0	10.0	19.7	17.8	39.4	27.3	9.5	69.3	> 99.99										
75			10.0																		
76			10.0																		
77	4.0	13.9	10.0	10.0	19.5	19.7	39.0	33.2	11.7	85.1	99.995										
78			10.0																		
78	4.0	12.4	10.0	10.0	2.1	17.4	4.2	42.1	15.1	1002.4	> 99.5										
79	4.0	14.9	10.0	10.0	18.9	20.4	37.8	24.9	9.1	65.9	99.657										
80	3.8	10.8	10.0	10.0	19.7	15.4	39.4	31.5	11.0	79.9	> 99.5										
81	3.6	10.4	10.0	10.0	17.6	14.9	35.2	32.1	11.2	91.2	99.784										
82			10.0																		
83			10.0																		
84	3.7	10.4	10.0	10.0	16.1	15.6	32.2	39.6	13.2	123.0	> 99.5										
85	4.0	12.6	10.0	10.0	20.0	18.5	40.0	25.1	8.6	62.8	99.936										
86	4.0	13.6	10.0	10.0	19.7	20.1	39.4	30.4	10.3	77.2	> 99.99										
87	4.0	10.9	10.0	10.0	17.6	15.8	35.2				> 99.5										
87			10.0																		
88	4.0	12.2	10.0	10.0	17.9	17.5	35.8	31.2	10.9	87.2	99.995										
89			10.0																		
90			10.0																		
91	4.0	13.3	10.0	10.0	18.1	19.0	36.2	35.7	12.5	98.6	> 99.99										
92	4.0	12.2	10.0	10.0	19.4	17.3	38.8	28.7	10.1	74.0	99.979										
92	5.0	18.1	10.0	10.0	22.0	25.5	44.0	31.8	11.3	72.3	> 99.99										
93	4.9	21.3	10.0	10.0	24.6	30.3	49.2	35.3	12.5	71.7	99.942										
94	4.9	19.8	10.0	10.0	29.0	27.6	58.0	32.1	11.5	55.3	99.814										
95	5.0	18.2	10.0	10.0	20.3	25.3	40.6	29.2	10.5	71.9	99.904										
96			10.0																		
97			10.0																		
98	5.0	22.7	10.0	10.0	29.2	31.5	58.4	28.0	10.1	47.9	99.278										
98			10.0																		

LAPORTE DEMONSTRATION - CALCULATED OPERATING PARAMETERS

DAY	IN FLOW GPM	TOD LOAD #/DAY	CAPACITY #/DAY	MEAS IN MCB PPM	CALC IN MCB PPM	MEAS IN TOD PPM	PROBE DLT D.O. PPM	O2 APPLIED #/DAY	PROBE DO MEAS TOD %/DO/TOD	TREAT EFFIC % OF FD
99	5.0	10.0	10.0							
100	5.0	19.0	10.0	35.9	27.1	71.8	6.8	2.4	9.5	95.430
101	4.9	19.8	10.0	35.2	28.2	70.4	5.6	2.0	8.0	99.996
102	5.0	18.0	10.0	24.1	25.0	48.2	33.5	12.1	69.5	99.392
103			10.0							
104			10.0							
105	5.1	16.2	10.0	20.6	22.7	41.2	20.0	7.1	48.5	99.942
106	4.9	15.8	10.0	32.2	22.1	64.4	19.6	7.0	30.4	> 99.5
107	4.9	13.8	10.0	19.9	21.1	39.8	17.0	5.5	42.7	99.697
108	4.9	13.1	10.0	26.9	18.2	53.8	17.1	6.2	31.8	> 99.5
109	4.9	13.1	10.0	27.6	18.2	55.2	23.3	8.4	42.2	99.373
110			10.0							
111			10.0							
112	4.9	11.7	10.0	20.7	16.1	41.4	12.1	4.4	29.2	99.228
113			10.0							
114	3.5	8.0	10.0	17.5	11.1	35.0	22.0	8.0	62.9	> 99.5
115	3.5	8.0	10.0	12.2	11.0	24.4	20.9	7.6	85.7	99.937
116	3.4	9.6	10.0	15.5	13.3	31.0	24.5	8.9	79.0	99.260
117			10.0							
118			10.0							
119	3.4	8.1	10.0	9.8	11.2	19.6	23.0	8.3	117.3	> 99.99
120	3.5	10.0	10.0	15.2	14.3	30.4	18.0	6.3	59.2	99.328
121	3.4	9.3	10.0	17.0	13.6	34.0	25.3	8.7	74.4	98.648
122	3.5	10.4	10.0	14.8	15.1	29.6	28.1	9.7	94.9	99.596
123	3.5		10.0							
124			10.0							
125			10.0							
126	3.5	12.0	10.0	9.7	17.1	19.3	26.0	9.1	134.6	> 99.5
127	3.4	12.1	10.0	13.3	17.3	26.6	29.4	10.3	110.5	> 99.5
128	3.5	11.6	10.0	11.5	16.2	22.9	29.1	10.4	127.0	> 99.5
129	3.5	12.5	10.0	4.2	17.7	8.4	26.3	9.3	311.6	> 99.5
130	3.3	10.7	10.0	6.5	15.1	13.0	20.4	7.2	156.9	> 99.5
131			10.0							
132			10.0							
133	3.5		10.0							
133	3.5		10.0							
133			10.0							

LAPORTE DEMONSTRATION - CALCULATED OPERATING PARAMETERS

DAY	IN FLOW GPM	TOD LOAD #/DAY	LOAD CAPACITY #/DAY	MEAS IN MCB PPM	CALC IN MCB PPM	MEAS IN TOD PPM	PROBE DLT D.O. PPM	O2 APPLIED #/DAY	PROBE DO MEAS TOD % DO/TOD	TREAT EFFIC % OF FD
134	3.4	10.1	10.0	63.2	14.3	126.4	28.1	9.9	22.2	48.253
134			10.0							
135	1.0		10.0	12.6		25.2	2.5	1.0	9.9	
136	1.0	3.0	10.0	0.0	3.6	0.0	3.1	1.3		98.144
137	2.0	5.8	10.0	23.3	6.8	46.5				83.098
138			10.0							
139			10.0							
140	1.9	5.0	10.0	8.5	6.1	16.9	3.9	1.6	23.1	96.034
141	2.9	8.9	10.0	33.5	10.9	66.9	1.5	0.6	2.2	81.041
142	0.0	0.0	10.0	0.0						> 99.5
143	1.0	2.6	10.0	0.0	3.8	0.0	1.9	0.7		98.541
144	1.0	2.4	10.0	0.0	3.6	0.0	0.6	0.2		99.274
145			10.0							
146			10.0							
147	0.9	3.5	10.0	0.0	5.3	0.0	1.0	0.3		99.427
148	0.9	3.2	10.0	0.0	4.8	0.0	2.2	0.7		> 99.5
149	1.9	5.5	10.0	33.6	7.5	67.2	3.5	1.3	5.2	70.362
149	2.1		10.0	27.3		54.6	7.1	2.5	13.0	
150			10.0							
151			10.0							
152			10.0							
153			10.0							
154	2.1		10.0				23.2	7.6		
155	0.0		10.0				2.8	1.2		
155	0.0		10.0				4.7	1.7		
155			10.0							
156	0.0		10.0				2.4	0.9		
157	0.0		10.0				3.0	1.1		
158	1.0		10.0				1.8	0.7		
159			10.0							
160			10.0							
161	0.9		10.0				10.7	3.5		
162	1.5	4.9	10.0	5.6	5.9	11.2	10.7	4.5	95.5	> 99.5
163	1.6	4.4	10.0	5.3	5.6	10.6	13.0	5.1	122.6	99.635
164	1.4	3.9	10.0	5.2	4.7	10.4	11.9	5.0	114.4	99.673
165			10.0	2.1		4.2				> 99.5
166			10.0							
167			10.0							
168			10.0	2.7						> 99.5
169	1.4	3.8	10.0	10.1	4.6	20.2	10.5	4.4	52.0	98.761
170	2.0	6.0	10.0	12.9	8.5	25.8	27.5	9.6	106.6	95.409
171	2.0	5.2	10.0	4.0	6.2	8.0	7.6	3.2	95.0	96.696
172	1.5		10.0							
173			10.0							

LAPORTE DEMONSTRATION - CALCULATED OPERATING PARAMETERS

DAY	IN FLOW GPM	TOD LOAD #/DAY	LOAD CAPACITY #/DAY	MEAS		CALC		MEAS IN TOD PPM	PROBE DLT D.O. PPM	O2 APPLIED #/DAY	PROBE DO MEAS TOD % DO/TOD	TREAT EFFIC % OF FD
				IN MCB PPM	IN MCB PPM	IN MCB PPM	IN MCB PPM					
174			10.0									
175	1.5	3.0	10.0	3.1	3.8	6.2	11.5	4.7	185.5		99.993	
176	1.8	4.6	10.0	4.6	5.7	9.2	12.3	5.0	133.7		> 99.5	
177	1.7	4.3	10.0	4.7	5.1	9.4	11.6	4.8	123.4		99.993	
178			10.0	7.0		14.0					> 99.5	
179			10.0									
180			10.0									
181			10.0									
182	1.5	4.8	10.0	3.9	7.8						> 99.99	
183	2.0	5.8	10.0	5.6	7.3	11.2	12.0	4.8	107.1		> 99.5	
184			10.0									
185	2.0	6.3	10.0	7.9	8.2	15.8	15.2	5.9	96.2		99.990	
186			10.0									
187			10.0									
188			10.0									
189	2.0	6.3	10.0	7.4	7.7	14.7	13.6	5.6	92.5		99.993	
190	2.0		10.0				11.6	4.8				
191	2.1	6.2	10.0	6.8	7.3	13.6	14.0	5.9	102.9		> 99.5	
192	1.9	4.8	10.0		6.1	15.9	15.9	6.4			> 99.5	
193	1.9	5.4	10.0		6.1		9.8	4.3			> 99.5	
194			10.0									
195			10.0									
196	1.9	4.6	10.0		5.2		5.0	2.2			> 99.5	
197	1.9	5.3	10.0	7.7	6.5	15.4	16.1	6.5	104.5		> 99.99	
198	2.5	7.2	10.0	10.0	9.1	20.0	20.4	8.0	102.2		> 99.5	
199	2.6	7.3	10.0	12.2	9.8	24.4	22.3	8.3	91.4		99.980	
200	2.5	6.6	10.0	8.3	8.7	16.6	17.1	6.5	103.0		> 99.5	
201			10.0									
202			10.0									
203	2.5	6.8	10.0	10.5	8.9	21.0	22.7	8.6	108.1		99.985	
204	2.5		10.0				5.2	2.2				
204			10.0									
205			10.0									
206	2.5	7.0	10.0	7.5	9.0	15.0	12.5	4.9	83.3		99.871	
206			10.0									
207	2.5	6.2	10.0	9.0	8.0	18.0	15.6	6.0	86.7		99.993	
208			10.0									
209			10.0									
210	2.5	6.6	10.0	8.2	7.7	16.4	23.4	10.0	142.7		99.981	
210			10.0									
211	3.0	7.8	10.0	12.4	10.7	24.8	20.7	7.5	83.5		> 99.5	
211			10.0									
212	3.0	7.5	10.0	11.8	10.4	23.5	19.8	7.2	84.3		> 99.99	
213	3.0	6.6	10.0	7.1	8.9	14.2	20.8	7.7	146.5		> 99.5	