

0613

# GRADUATE AERONAUTICAL CALIFORNIA INSTITUTE OF TECHNOLOGY

**GALCIT Report FM95-1**

**Chemical Reactions in Turbulent Mixing Flows**

Paul E. Dimotakis and Anthony Leonard

Air Force Office of Scientific Research  
Grant No. F49620-92-J-0290

Final Technical Report: Period ending 31 October 1994

not released

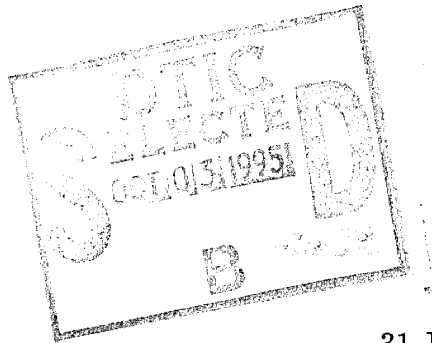

AIR FORCE  
NOTICE TO  
THIS  
APPROPRIATE  
DISTRIBUTION  
STANDARD

31 January 1995

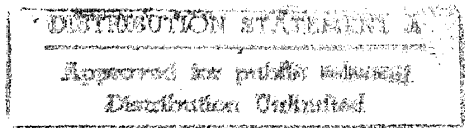

Firestone Flight Sciences Laboratory

Guggenheim Aeronautical Laboratory

Karman Laboratory of Fluid Mechanics and Jet Propulsion

1995

19951002 027

Pasadena

GRADUATE AERONAUTICAL LABORATORIES  
CALIFORNIA INSTITUTE of TECHNOLOGY  
Pasadena, California 91125

Chemical Reactions in Turbulent Mixing Flows

Paul E. Dimotakis\* and Anthony Leonard\*\*

Air Force Office of Scientific Research  
Grant No. F49620-92-J-0290

Final Technical Report: Period ending 31 October 1994

31 January 1995

---

\* Professor, Aeronautics & Applied Physics.

\*\* Professor, Aeronautics.

REPORT DOCUMENTATION PAGE			Form Approved OMB No. 0704-0188	
Public reporting burden for this collection of information is estimated to average 1 hour per response, including the time for reviewing instructions, searching existing data sources, gathering and maintaining the data needed, and completing and reviewing the collection of information. Send comments regarding this burden estimate or any other aspect of this collection of information, including suggestions for reducing this burden, to Washington Headquarters Services, Directorate for Information Operations and Reports, 1215 Jefferson Davis Highway, Suite 1204, Arlington, VA 22202-4302, and to the Office of Management and Budget, Paperwork Reduction Project (0704-0188), Washington, DC 20503.				
1. AGENCY USE ONLY (Leave blank)	2. REPORT DATE January, 1995	3. REPORT TYPE AND DATES COVERED Final Tech. Rept., period end 10/31/94		
4. TITLE AND SUBTITLE  Chemical Reactions in Turbulent Mixing Flows			5. FUNDING NUMBERS  PE - 61102F PR - 2308 SA - BS G - F49620-92-J0290	
6. AUTHOR(S)  Paul E. Dimotakis and Anthony Leonard				
7. PERFORMING ORGANIZATION NAME(S) AND ADDRESS(ES)  California Institute of Technology 1201 E. California Blvd. Pasadena, CA 91125			8. PERFORMING ORGANIZATION REPORT NUMBER  GALCIT Report FM95-1	
9. SPONSORING/MONITORING AGENCY NAME(S) AND ADDRESS(ES)  AFOSR/NA Building 410 Bolling AFB DC 20332-6448			10. SPONSORING/MONITORING AGENCY REPORT NUMBER	
11. SUPPLEMENTARY NOTES				
12a. DISTRIBUTION/AVAILABILITY STATEMENT  Approved for public release; distribution is unlimited			12b. DISTRIBUTION CODE	
13. ABSTRACT (Maximum 200 words)  This is the final report of our program on "Chemical Reactions in Turbulent Mixing Flows," supported under the AFOSR Grant No. F49620-92-J-0290, which was granted a no-cost extension to permit the completion of the Supersonic Shear Layer Facility upgrade that extended the operating envelope to higher Mach-number flows. As part of this upgrade, a variety of new diagnostic and safety features were also implemented in this unique facility.  The purpose of this program has been to conduct fundamental investigations of turbulent mixing, chemical reaction and combustion processes in turbulent, subsonic and supersonic flows. Scientific progress in these areas was documented in our most recent Annual Report (Dimotakis & Leonard 1994).				
14. SUBJECT TERMS Turbulent mixing, supersonic turbulence, shear layers, jets, chemical reaction, image correlation velocimetry, shock wave, turbulent diffusion flame			15. NUMBER OF PAGES 19	16. PRICE CODE
17. SECURITY CLASSIFICATION OF REPORT Unclassified	18. SECURITY CLASSIFICATION OF THIS PAGE Unclassified	19. SECURITY CLASSIFICATION OF ABSTRACT Unclassified	20. LIMITATION OF ABSTRACT UL	

### Abstract

This is the final report of our program on "Chemical Reactions in Turbulent Mixing Flows," supported under the AFOSR Grant No. F49620-92-J-0290, which was granted a no-cost extension to permit the completion of the Supersonic Shear Layer Facility upgrade that extended the operating envelope to higher Mach-number flows. As part of this upgrade, a variety of new diagnostic and safety features were also implemented in this unique facility.

The purpose of this program has been to conduct fundamental investigations of turbulent mixing, chemical reaction and combustion processes in turbulent, subsonic and supersonic flows. Scientific progress in these areas was documented in our most recent Annual Report (Dimotakis & Leonard 1994).

Accession For	
DTIC GRAZ	<input checked="" type="checkbox"/>
DTIC TAB	<input type="checkbox"/>
Unannounced	<input type="checkbox"/>
Justification	
By	
Distribution/	
Availability Codes	
Dist	Special
A-1	

## 1. Introduction

This is the final report for the work "Chemical Reactions in Turbulent Mixing Flows," supported under the AFOSR Grant No. F49620-92-J-0290 and performed at the Graduate Aeronautical Laboratories at the California Institute of Technology.

The work described here covers the completion of a major upgrade of the Supersonic Shear Layer (S<sup>3</sup>L) Facility, for which a no-cost extension was granted, beyond the originally-scheduled end of this effort (31 May 1994). Support for the upgrade of the Supersonic Shear Layer (S<sup>3</sup>L) Facility was also contributed under AFOSR sponsorship for our URI effort, "Interaction of Chemistry, Turbulence, and Shock Waves in Hypervelocity Flow," Grant No. F49620-93-1-0338, which cofunds parts of this effort.

The body and concluding documentation of the scientific work performed under this Grant was described in our most recent annual report (Dimotakis & Leonard 1994).

## 2. Supersonic Shear Layer Facility upgrade

A two-stage upgrade of the GALCIT Supersonic Shear Layer (S<sup>3</sup>L) Facility has recently been completed to allow the study of high-compressibility, chemically-reacting and nonreacting shear-layer flows. A third stage of this upgrade, involving the pre-heating of the top of the two freestreams, is still to be completed, pending the anticipated, higher Mach number flow, studies.

The specifications of the facility, at each stage in its evolution, are outlined in Table 1. An extensive documentation of the Mk. I Facility can be found in Hall & Dimotakis (1989) and Hall (1991). Additionally, a discussion of the special handling and safety concerns required in the use of the H<sub>2</sub>/F<sub>2</sub>/NO chemical system is available in Mungal (1983).

As indicated in Table 1, the second stage of the facility upgrade, to Mk. III status, completed in October 1994, allows operation at higher freestream Mach numbers and provides additional flow visualization capabilities. Experiments that exploit the full capabilities of the newly-expanded operating envelope of this Facility have not begun, as yet, pending an internal safety review by the Aeronautics Department, at Caltech. This is expected to be completed in the spring of 1995. The indicated completion date for the Mk. IV Facility upgrade represents a projection, at this writing.

**Table 1: Supersonic Shear Layer facility evolution**

For all facility configurations:

Top-stream gases:	H <sub>2</sub> , NO, He, Ar, N <sub>2</sub>
Bottom-stream gases:	F <sub>2</sub> , He, Ar, N <sub>2</sub>
Nominal run time:	3 sec
Nominal test-section (static) pressure:	1 atm

Status:	Mk. I	Mk. II	Mk. III	Mk. IV
Completion:	7/89	12/93	10/94	10/95
Freestream Mach numbers:	$M_1 \leq 2.5$	$M_1 \leq 2.5$	$M_1 \leq 3.2$	$M_1 \leq 3.2$
	$M_2 \leq 0.3$	$M_2 \leq 1.2$	$M_2 \leq 1.2$	$M_2 \leq 1.2$
Max. stagnation temp.:	300 K	300 K	300 K	600 K
Span-view optical access:	Y	Y	Y	Y
Plan-view optical access:	N	N	Y	Y
Flow-seeding capability:	N	N	Y	Y
Catch-bag enclosure:	N	N	Y	Y

The first stage of this upgrade rendered the facility capable of producing bi-supersonic shear-layer flows, *i.e.*, shear-layer flows with both freestreams supersonic. These modifications, co-sponsored by a AFOSR Aerothermochemistry URI program,<sup>†</sup> were completed in December 1993 and have since been employed in an initial study of the effect of the presence of elliptical-flow regions on supersonic shear layer flows. A presentation of the results of the first experiments to utilize this capability was made at the November 1994 Fluid Dynamics Division meeting (Atlanta, Georgia) of the American Physical Society (Slessor & Dimotakis 1994).

As part of the upgrade to Mk. III status, the splitter plate (see Figs. 1 and 2),

---

<sup>†</sup> Titled, "Interaction of Chemistry, Turbulence, and Shock Waves in Hypervelocity Flow," AFOSR Grant No. F49620-93-1-0338.

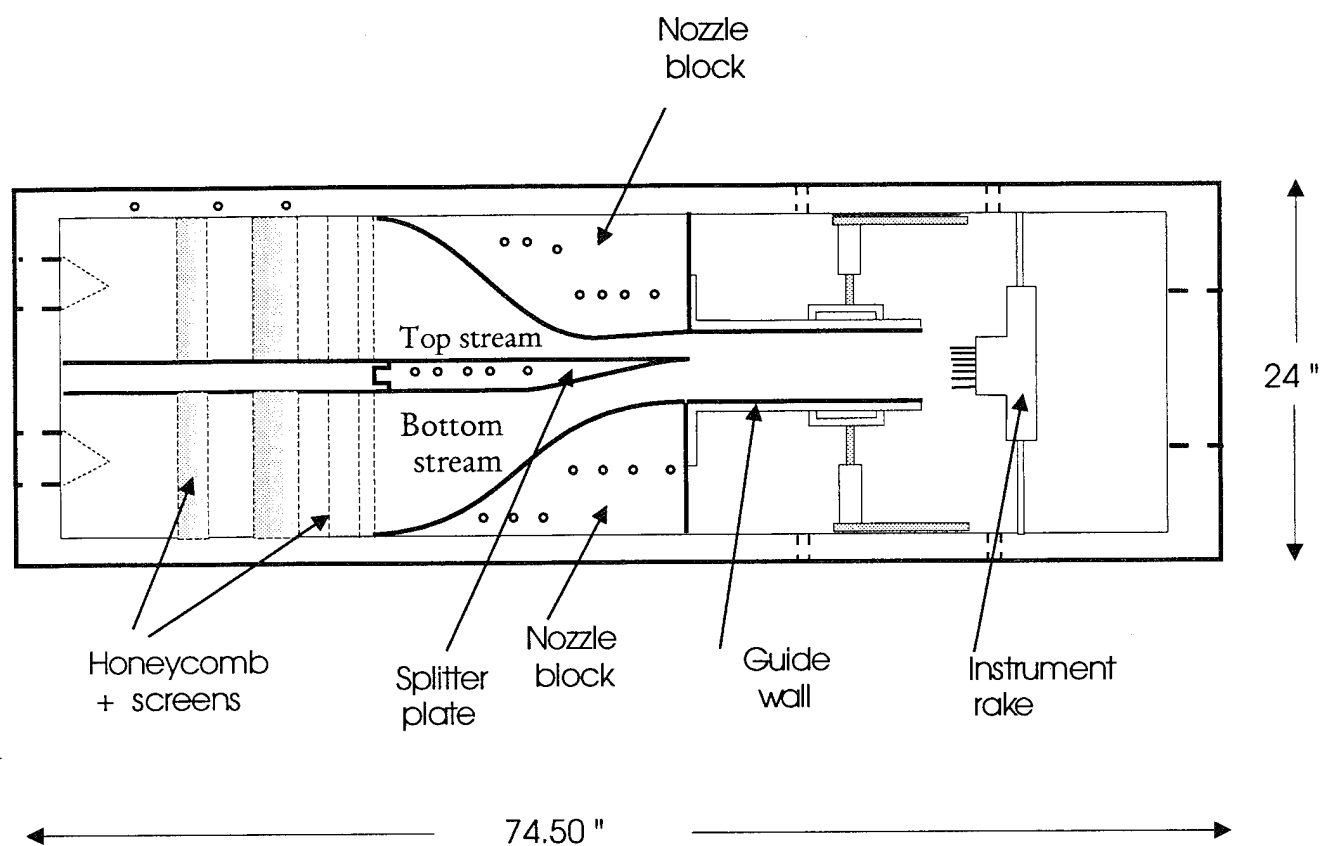

FIG. 1 Test section cutaway schematic (front guidewall removed).

which separates the freestreams in the upstream plenum, is now rigidly keyed to the test-section sidewalls. This locating system eliminates the splitter plate deflection which was observed in experiments conducted in the Mk. I and Mk. II Facility at high-pressure conditions. As part of this upgrade, optical access has also been provided to allow the spanwise view of the test section to be recorded, permitting (simultaneous) plan and spanwise visualizations of the shear layer. Access ports have also been added to the flow-delivery system, sufficiently upstream of the flow-management devices, to allow introduction of tracer gases to the flow, effectively "seeding" either, or both, of the two freestreams in anticipation of the utilization of laser diagnostics presently under development. Introduction of such tracers, *e.g.*, acetone, increases the number of flow visualization techniques available for use in this facility and will also allow a qualitative comparison with similar realizations obtained elsewhere, *e.g.*, Miller *et al.* (1993).

A major part of the second-stage upgrade was the construction of an enclosure

for a new, larger-capacity, gas containment and disposal catch bag.<sup>‡</sup> This gas containment bag, which holds all the substances used and/or produced in the course of an experimental run,<sup>‡</sup> was capable of capturing the gases employed in a run of the Mk. I/II Facility. The increased gas volume anticipated in future experiments in this Facility, however, dictated the larger catch bag. Additionally, the new bag is now enclosed in a fire-proof, acoustically-insulated structure, which serves three primary functions.

- a. The enclosure, which is open at the bottom and ventilated with two high-capacity fans, through a duct that projects 10' above the top of the building wall, will assist in the containment, monitoring, and disposal of any plausible breach of the integrity of the bag.
- b. The enclosing structure was designed to provide a significant amount of acoustic dampening, reducing the acoustic noise radiated to the surrounding environment by an estimated 15 – 20 dB.

Finally,

- c. the enclosure protects the bag material from the harmful effects of sunlight and wind, which are important factors to bag lifetime.

The third stage of the upgrade, *i.e.*, to Mk. IV status is expected to be completed in the latter portion of 1995. This work involves the installation and testing of a gas-heating system, to allow us to raise the stagnation temperature of the top freestream gas. This is necessary because, as the top freestream Mach number increases, the static temperature decreases in that stream. Our chemical-kinetic simulations of this condition indicate that an increase in stagnation temperature is necessary if we are to retain the ability to conduct experiments in the fast-kinetic regime at the higher Mach numbers the Facility has been upgraded for.

---

<sup>‡</sup> This was funded by the California Institute of Technology, in support of this effort. The cost for this project was slightly in excess of \$70,000.

<sup>‡</sup> Refer to Mungal (1983) and Hall (1991) for discussion of gas containment and disposal issues.

## 2.1 Stage 1: Mk. I to Mk. II transition

The first upgrade of this facility, from the Mk. I to the Mk. II configuration, extended the operating envelope to include a supersonic bottom freestream. This configuration allows the investigation of bi-supersonic shear layer flows, *i.e.*, shear-layer flows with two supersonic freestreams. In this case, the absence of an elliptical region in the flow admits the possibility that these flows may differ from their supersonic/subsonic counterparts, an issue that is currently under study as part of this effort. We should note that this upgrade does not remove the capability of returning the facility to a subsonic bottom freestream configuration, or to a subsonic top and bottom freestream configuration, as necessary.

These modifications, which preserve the modular nature of the Mk. I facility, permit transonic bottom freestream Mach numbers, *i.e.*,  $M_2 \leq 1.2$ . A new bottom freestream nozzle block, with a design Mach number of 1.13, was fabricated, in addition to a new bottom freestream metering valve, which provides the increased mass flux required for operation in the Mk. II configuration. As indicated above, these modifications are reversible, *i.e.*, a return to the Mk. I, or even all subsonic, configuration is easily realized.

## 2.2 Stage 2: Mk. II to Mk. III transition

This transition involves the splitter-plate modifications to allow the higher Mach-number runs to be realized, by increasing the maximum top-stream plenum pressure of the facility to 50 atm. Additionally, plan-view optical as well as tracer gas seeding access ports have been installed. These, as well as other operating-envelope and safety features comprising this configuration are discussed below.

### 2.2.1 Splitter plate modifications

In our first runs at  $M_1 = 2.5$ , a major design flaw in the Mk. I/II facility was exposed. The larger plenum pressures required in these runs ( $p_{01} \approx 20$  atm) caused the failure of a doweling alignment pin, which ended up serving as a load-bearing pin. While a minor redesign corrected the alignment-pin problem, we also measured a significant downward deflection of the splitter plate at these higher pressures. Following the pin failure, the original (Mk. I/II) splitter plate, a 17-4 stainless-steel machined part, was supported approximately 11" from the downstream end and acted as a cantilever beam from this point on, downstream. At the lower plenum pressures encountered in the  $M_1 = 1.5$  runs, the downward deflection of the splitter tip was insignificant, but at the plenum pressures required for the  $M_1 \approx 2.5$  flows, the splitter plate deflected as much as 0.070". This deflection effectively changed the supersonic nozzle contour, to a degree that affected the uniformity of the supersonic freestream flow at the inlet plane, as evident in schlieren photographs recorded during these runs.

The degradation of the flow quality at this condition and the even larger deflections anticipated at the plenum pressures required for the future  $M_1 = 3.2$  runs ( $p_{01} \approx 50$  atm), dictated a redesign of the splitter plate and its locating system. This new (Mk. III) splitter plate, shown in Fig. 2, is "keyed" to the sidewalls to within 3" of its downstream end (*vs.* 11" in Mk. I/II configuration), providing a virtually rigid structure, even at the maximum design plenum pressures. Simple beam theory analysis indicates that the downstream end, or tip, of the splitter plate would deflect less than 0.001" at the maximum loading of 50 atm. As a validation, the same analysis, when applied to the Mk. I/II configuration, reproduced the deflection of 0.070" measured for the  $M_1 = 2.5$  cases.

To accept the (male) keys on the sides of the splitter plate, a pair of (female) keyways, shown in Figs. 3 and 5, were designed as 3/8"-thick inserts to the Mk. I/II facility sidewalls, shown in Figs. 4 and 6. These inserts, fabricated from 15-5 stainless steel, are housed in machined cavities in the aluminum sidewalls. The location and orientation of these cavities in the sidewalls is of critical importance to the alignment of the test section, and consequently, the quality of flow produced in the Mk. III and Mk. IV facilities.

In order to ensure adequate overall alignment of the sidewalls/keyways, centerbody, and splitter plate (see Fig. 7), a set of steel locating pins and bushings were installed at opposite corners of the test section. When engaged, these pins locate

Tolerances for the upper and lower surfaces are given on the attached drawing, number S-1A.

Beveled edge is for ease of assembly.

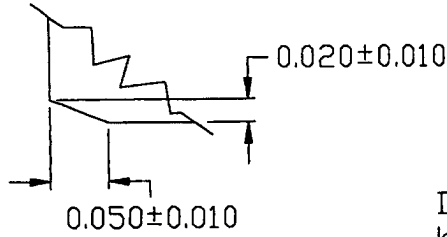

DETAIL C  
SCALE: 5X

6.012<sup>+0.000</sup><sub>-0.001</sub>

Double lines are the bevel in detail C (4 PLCS.)

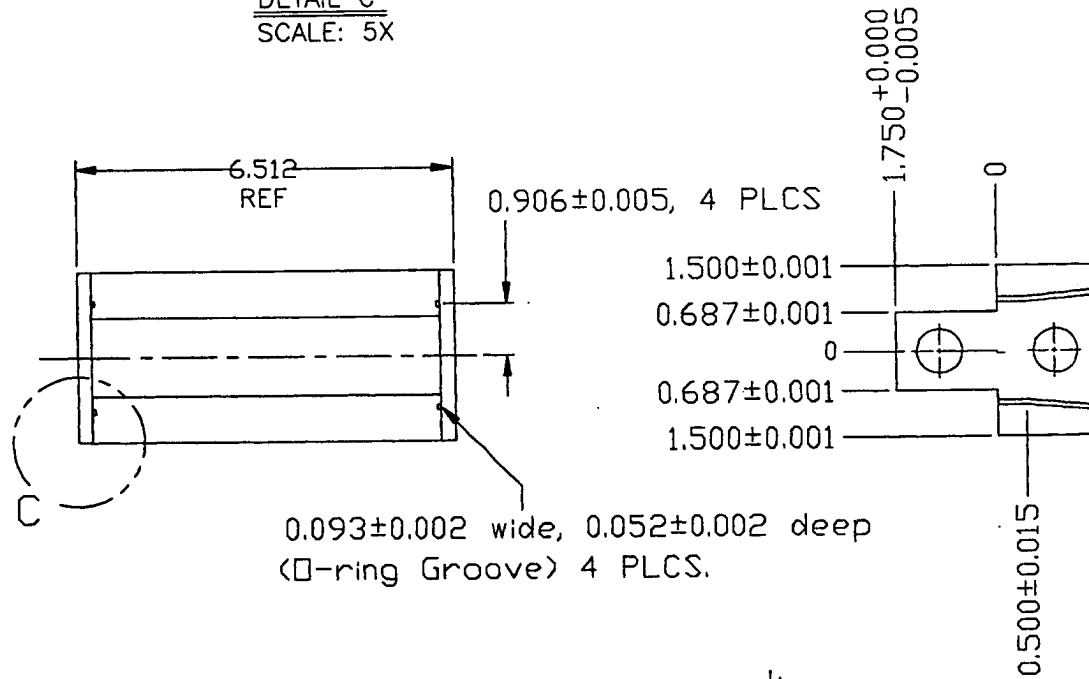

Lip outside □-ring groove

0.060<sup>+0.015</sup><sub>-0.000</sub>

17.717 REF

20.500 REF

0.250 REF

Radius to 0.250 ± 0.030  
Must match mating part

and lower  
attached

6.012<sup>+0.000</sup>  
-0.001

Mating surface for pt. K-2

Double lines are the  
level in detail C (4 PLCS.)

Mating surface for pt. K-1

0.06±0.005, 4 PLCS

1.500±0.001

0.687±0.001

0.687±0.001

1.500±0.001

0.052±0.002 deep  
4 PLCS.

0.500±0.015

Coordinates of lower surface  
are in file splat05.128  
(ASCII file, 128 pts/inch)

O-ring groove runs  
along edge (see  
Detail A) starting  
at 4.000 on lower side,  
6.000 on upper side

20.500  
REF

0.005 REF

DETAIL B  
SCALE: 5X

groove

17.717 REF

20.500  
REF

1.500 REF

0.250 REF

Radius to 0.250±0.030  
to match mating part

DETAIL "A"  
1/2 SCALE

1	S-1		17-4PH COND.
REQ	PART.NO.	DESCRIPTION	MATERIAL
			CALIFORNIA INSTITUTE
		DATE	SCALE 1/4
DRAWN BY	GMV	12/93	SPLITTER PLATE TEST SECTION
REVISED	CLB	6/17/94	

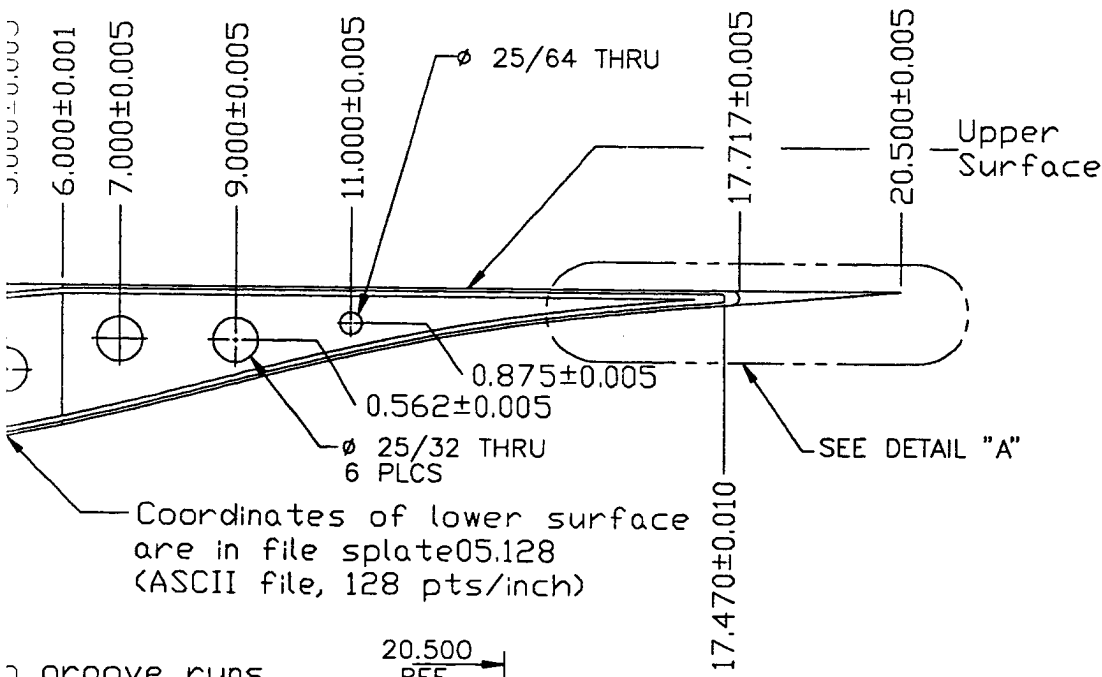
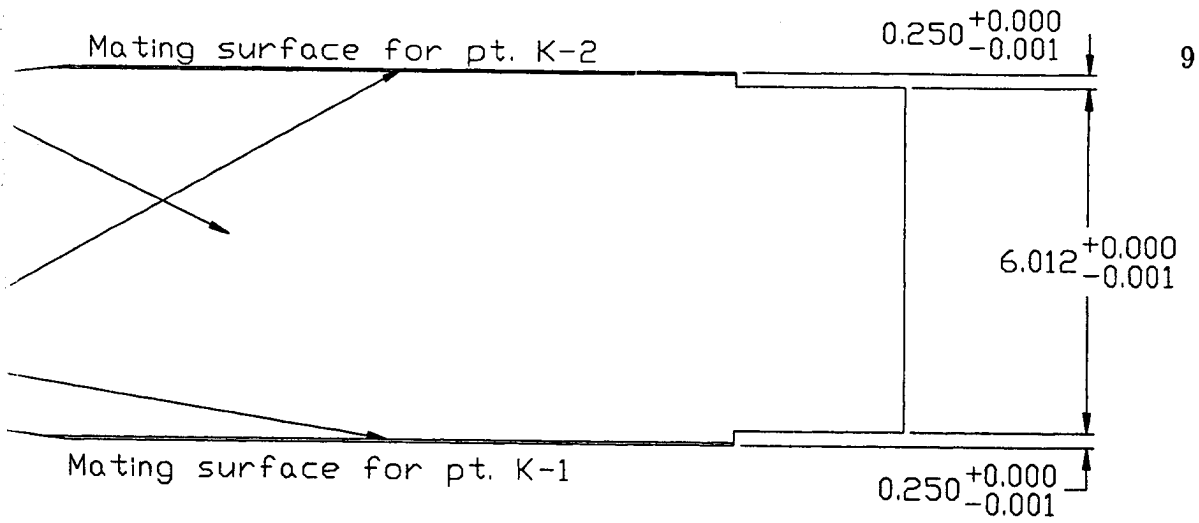

g groove runs  
edge (see  
(A) starting  
000 on lower side,  
on upper side

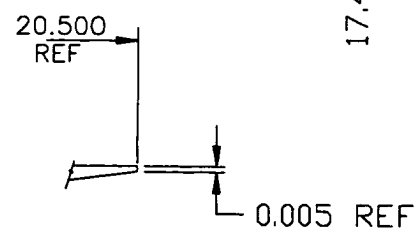

DETAIL B  
SCALE: 5X

500 REF

1	S-1		17-4PH COND. H900	1
REQ	PART.NO.	DESCRIPTION	MATERIAL	ITEM
			CALIFORNIA INSTITUTE OF TECHNOLOGY	
		DATE	SCALE 1/4	
DRAWN BY	GHY	12/93	SPLITTER PLATE TEST SECTION	DRAWING NO.
REVISED	CLB	6/17/94		S-1

FIG. 2 The modified splitter plate: fabrication drawing

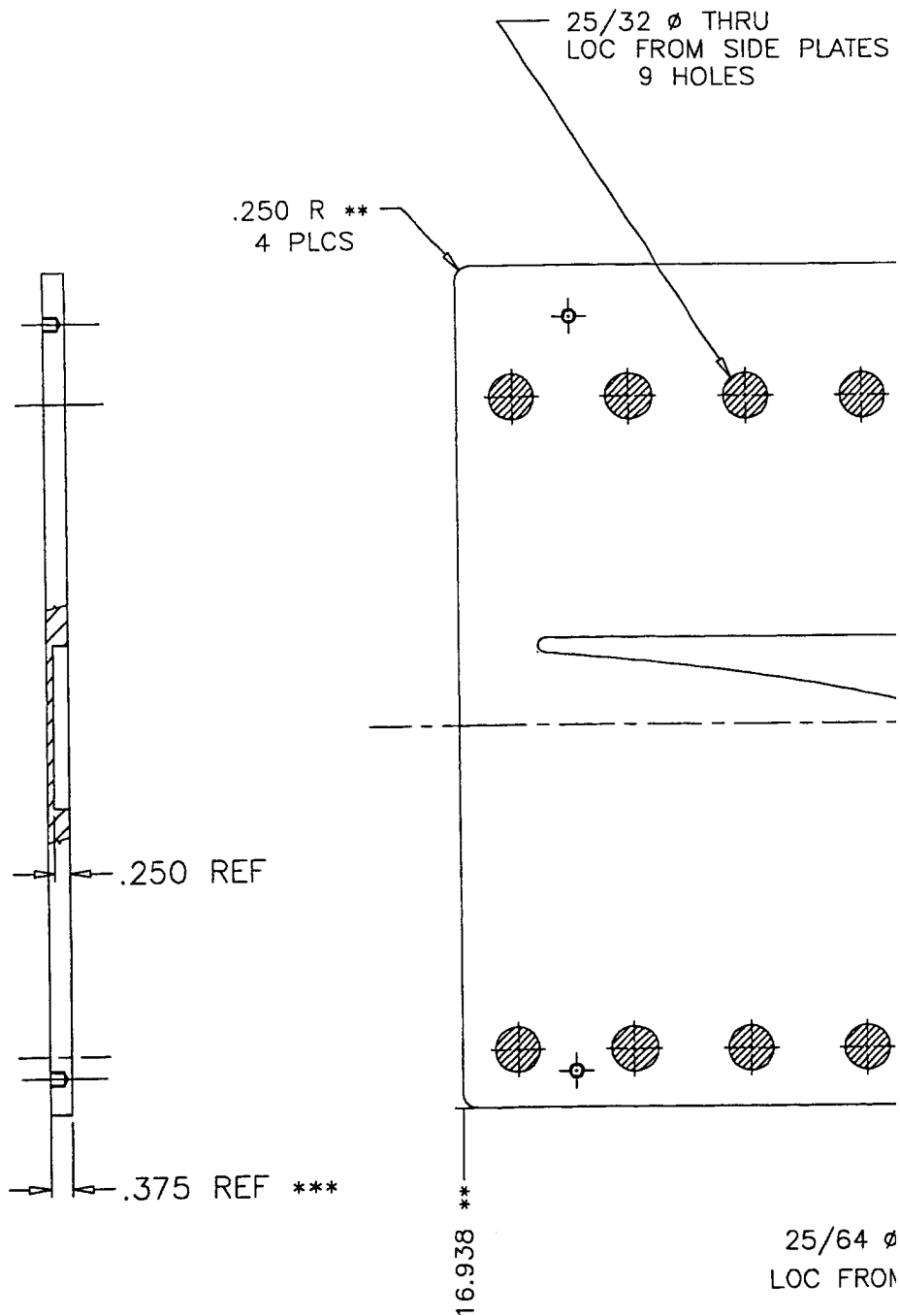

\*\* These are the nominal length and width. The actual dimensions need to be determined from the location and size of the actual pockets in the sideplates. The finished length and width of the keyways must be at least 0.004 inches and no more than 0.006 inches than the respective pockets.

\*\*\* The keyway must be no lower than 0.002 inches below the edge of the pocket and no higher than 0.001 inches above the edge of the pocket for the entire perimeter.

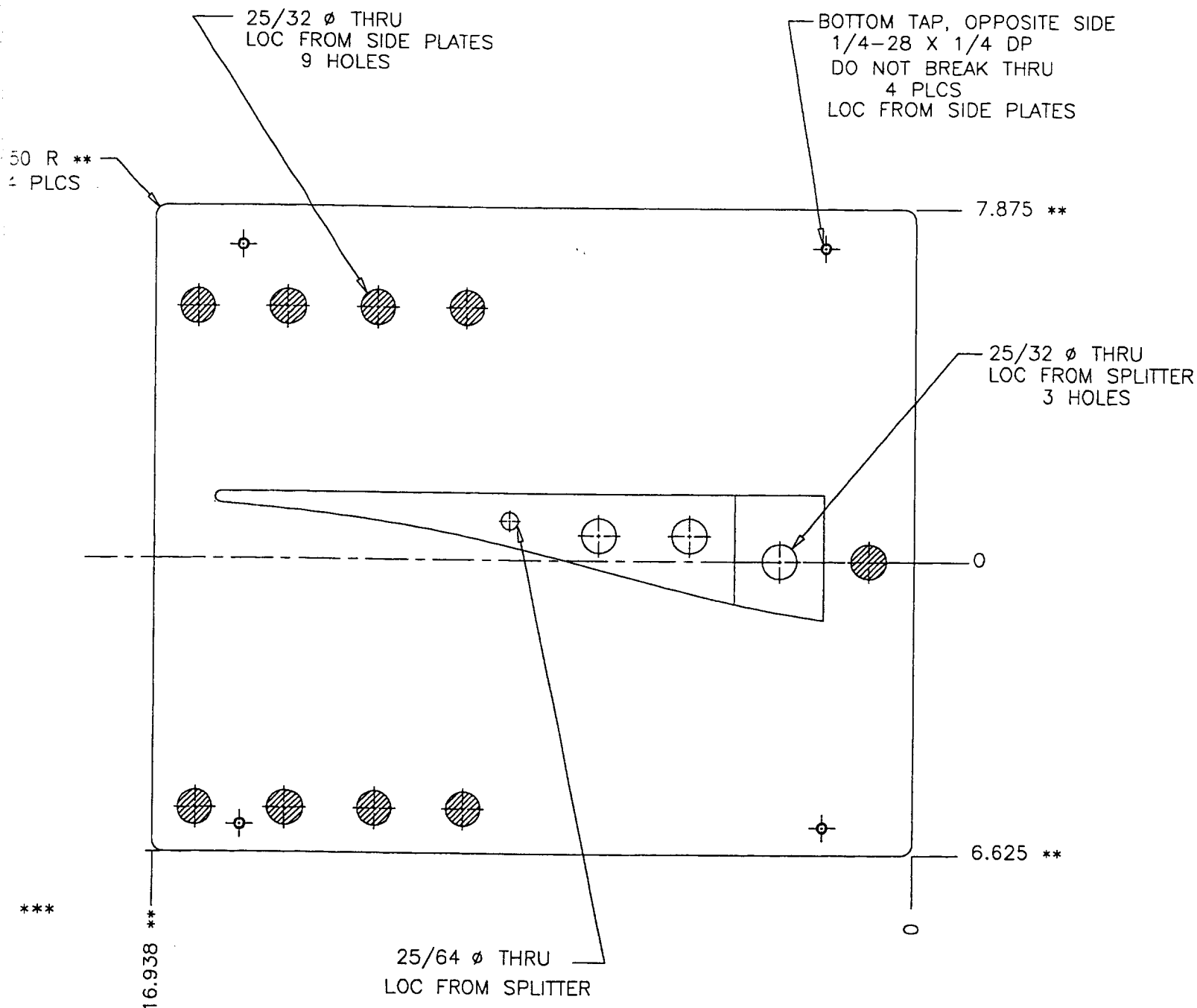

nominal length and width. The actual length and width to be determined from the location of the actual pockets in the sideplates. The nominal width of the keyways must be at least 0.002 inches and no more than 0.006 inches smaller than the nominal width of the pockets.

The depth of the pockets must be no lower than 0.002 inches below the nominal depth of the pocket and no higher than 0.001 inches above the nominal depth of the pocket for the entire perimeter.

1	K-1		15-5 PH COND. H90	
REQ	PART.NO.	DESCRIPTION	MATERIAL	
		W.O.	CALIFORNIA INSTITUTE OF TECHNOLOGY	
		DATE	SCALE	1/4
DRAWN BY	GMY	1/94	TITLE L.H. KEYWAY TEST SECTION	
REVISED	CLB	7/27/94	DWG. NO. K-1A	
NEXT ASSY				

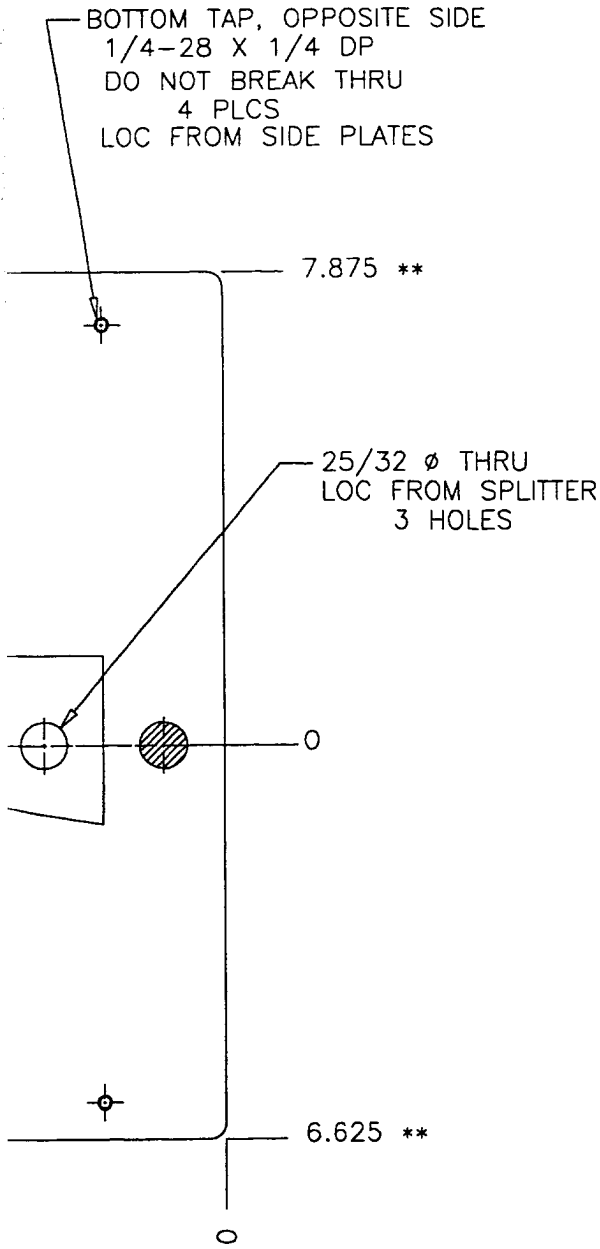
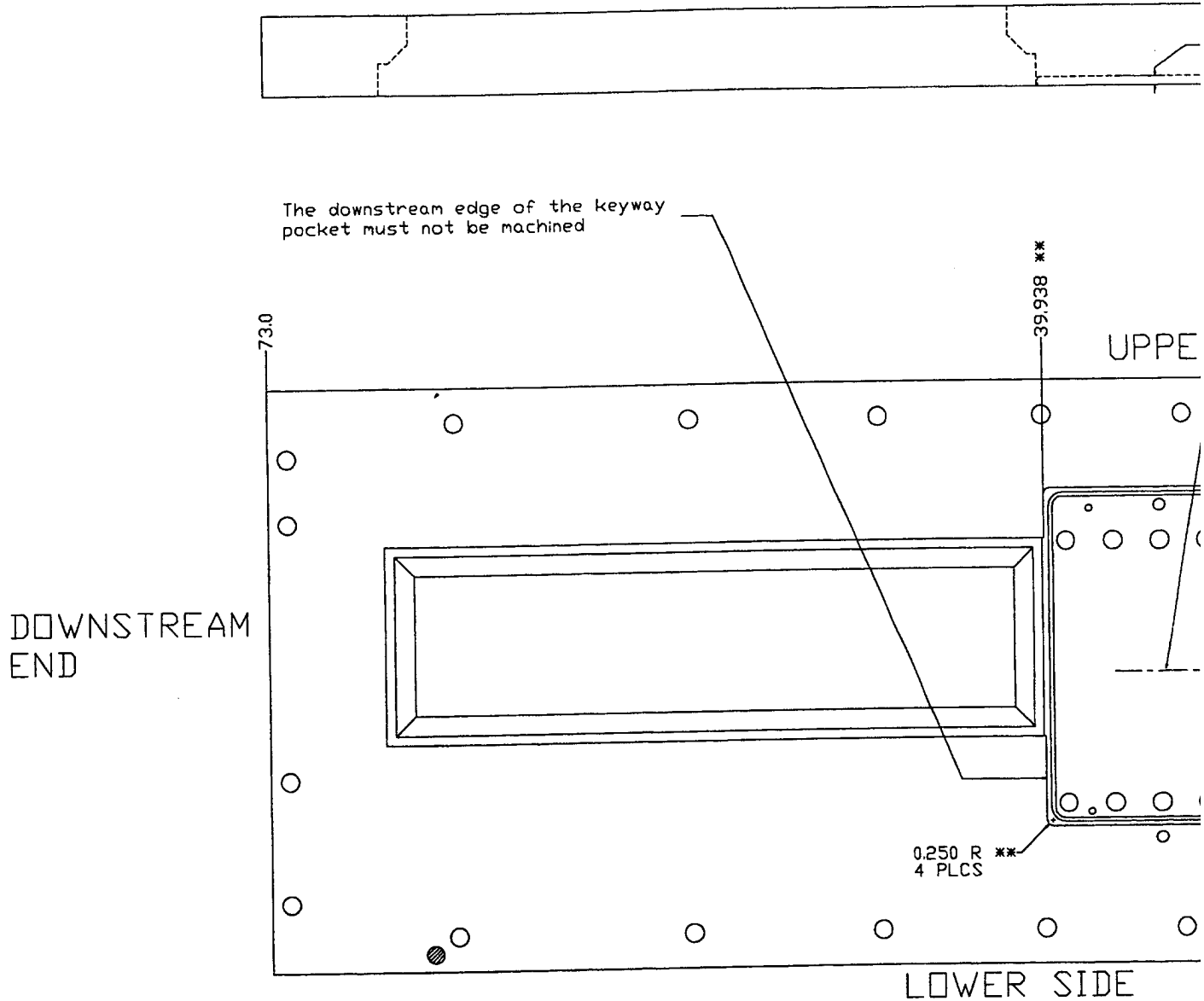

FIG. 3 The left-hand keyway insert: fabrication drawing

K-1				15-5 PH COND. H900	3
T.NO.	DESCRIPTION			MATERIAL	ITEM
	W.O.	CALIFORNIA INSTITUTE OF TECHNOLOGY			
	DATE	SCALE	1/4		
BY	1/94	TITLE		DWG. NO.	CHG.
LB	7/27/94	L.H. KEYWAY TEST SECTION		K-1A	



\*\* These measurements are the nominal measurements of the position of these pockets may differ.

The upper (flat) surface of the splitter plate (pt. S-1) (DATUM) of part SP-1 when the keyways are forced to fit.

The gap between the upstream (tongue) end of the splitter plate (pt. S-1) and the centerbody (pt. C-1) must be no more than 0.005 inches when the keyways are forced to fit the downstream side of the pockets.

See also Dwgs. A-1 and A-2.

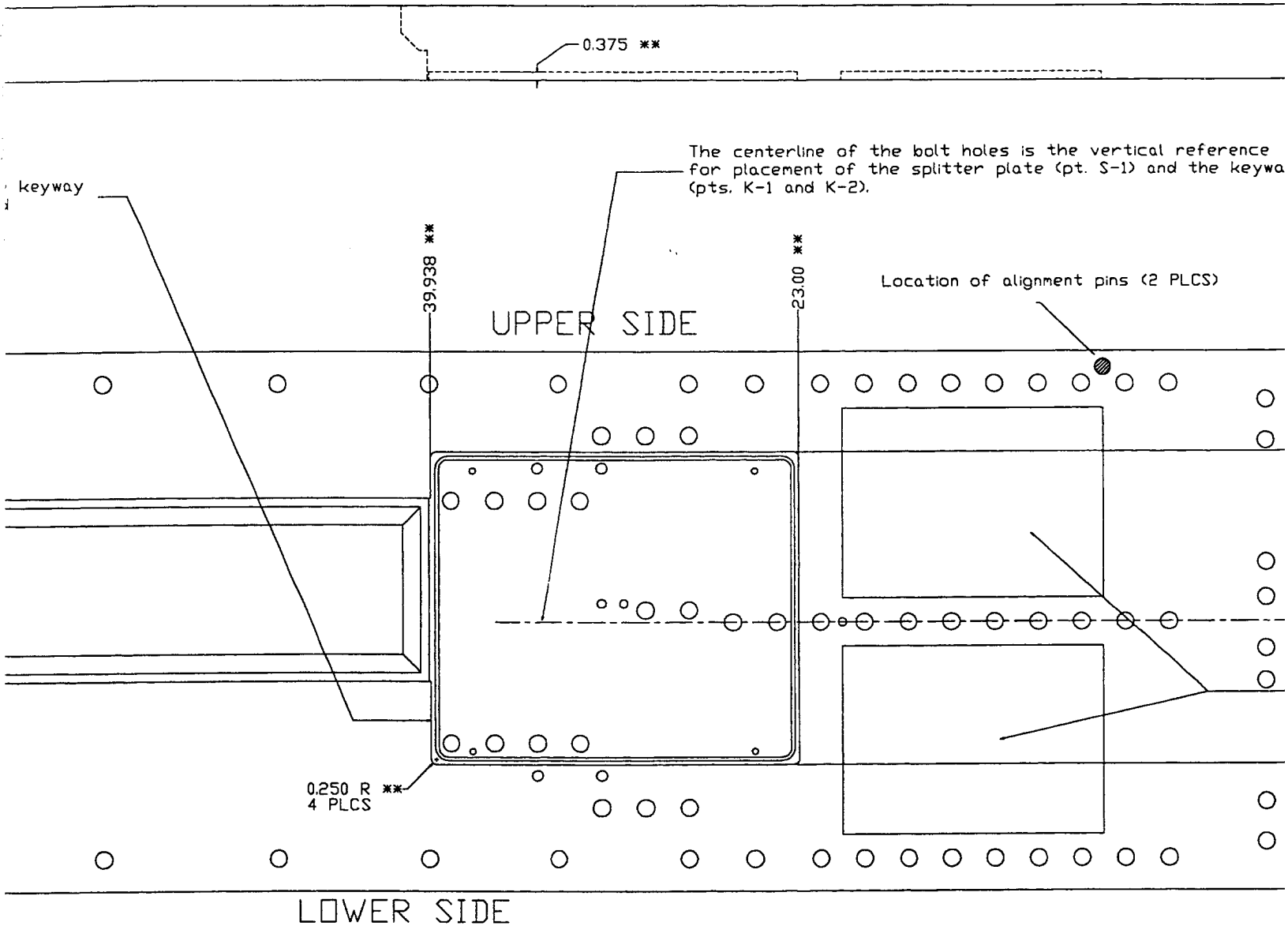

Dimensions are the nominal measurements of the existing keyway pockets. The actual size and shape of the keyway pockets may differ.

The splitter plate (pt. S-1) must be  $1.500 \pm 0.002$  inches above the top of the keyways are forced to the lower side of the pockets.

The chamfered (tongue) end of the splitter plate must be no more than 0.005 inches from the body (pt. C-1) must be no more than 0.005 inches from the keyways are forced to the lower side of the pockets.

	SP-1	Existing Part	
REQ.	PART NO.	DESCRIPTION	MATERIAL
SCALE = 1/10		CALIFORNIA INSTITUTE OF SUPERSONIC SHEAR LAYER	
DRAWN	CLB 7/27/94	TITLE L.H. SIDEPLATE	
REVISED	CLB 8/2/94		

The centerline of the bolt holes is the vertical reference for placement of the splitter plate (pt. S-1) and the keyways (pts. K-1 and K-2).

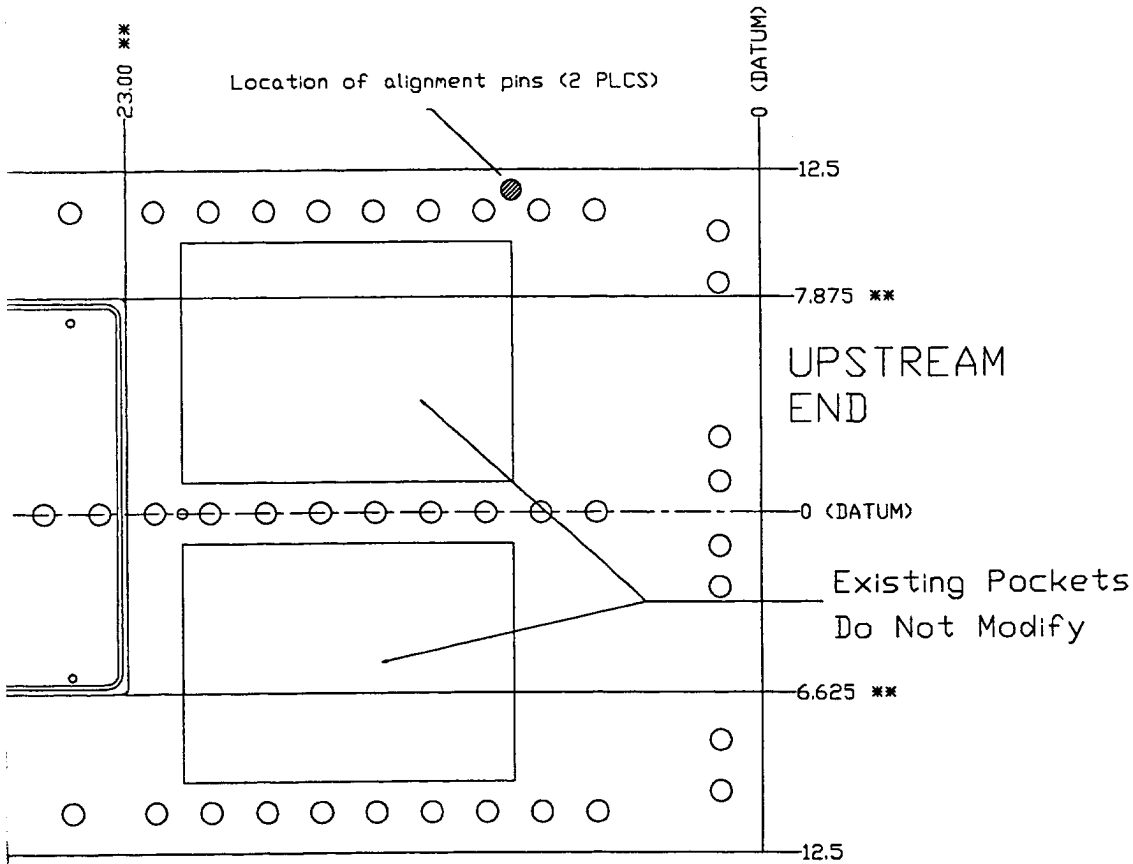

ing keyway pockets. The actual size and

be  $1.500 \pm 0.002$  inches above the centerline  
er side of the pockets.

FIG. 4 The left-hand sidewall: modification drawing

SP-1	Existing Part		
PART NO.	DESCRIPTION	MATERIAL	ITEM
SCALE= 1/10	CALIFORNIA INSTITUTE OF TECHNOLOGY SUPERSONIC SHEAR LAYER FACILITY		
DATE	TITLE	DWG. NO.	
CLB 7/27/94	L.H. SIDEPLATE	SP-1	
CLB 8/2/94			

BOTTOM TAP, OPPOSITE SIDE  
1/4-28 X 1/4 DP  
DO NOT BREAK THRU  
4 PLCS  
LOC FROM SIDE PLATES

7.875 \*\*

25/32  $\emptyset$  THRU  
LOC FROM SPLITTER  
3 HOLES

0

6.625 \*\*

0

\*\* These are nominal dimensions. The actual dimensions need to be determined from the location and size of the actual pockets in the sideplates. See drawing number K-1A for further details

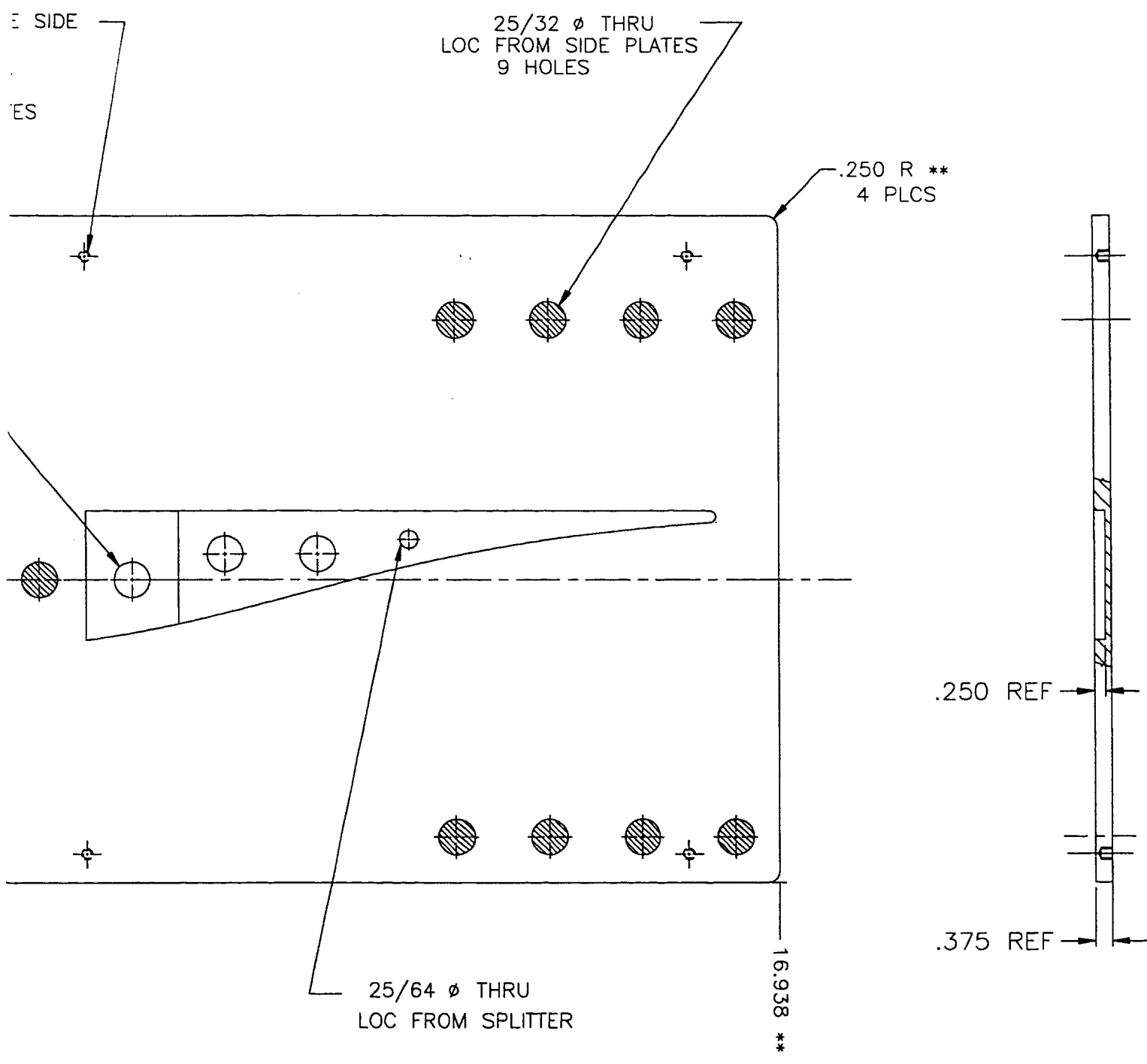

ons. The actual  
etermined from the location  
ockets in the sideplates.  
A for further details

1	K-2		15-5 PH COND. H900	2
REQ	PART.NO.	DESCRIPTION	MATERIAL	ITEM
		W.O.	CALIFORNIA INSTITUTE OF TECHNOLOGY	
		DATE	SCALE	1/4
DRAWN BY	GMV	1/94	TITLE	R.H. KEYWAY
REVISED	CLB	7/27/94		DWG. NO.
NEXT ASSY				K-2A
				CHG.

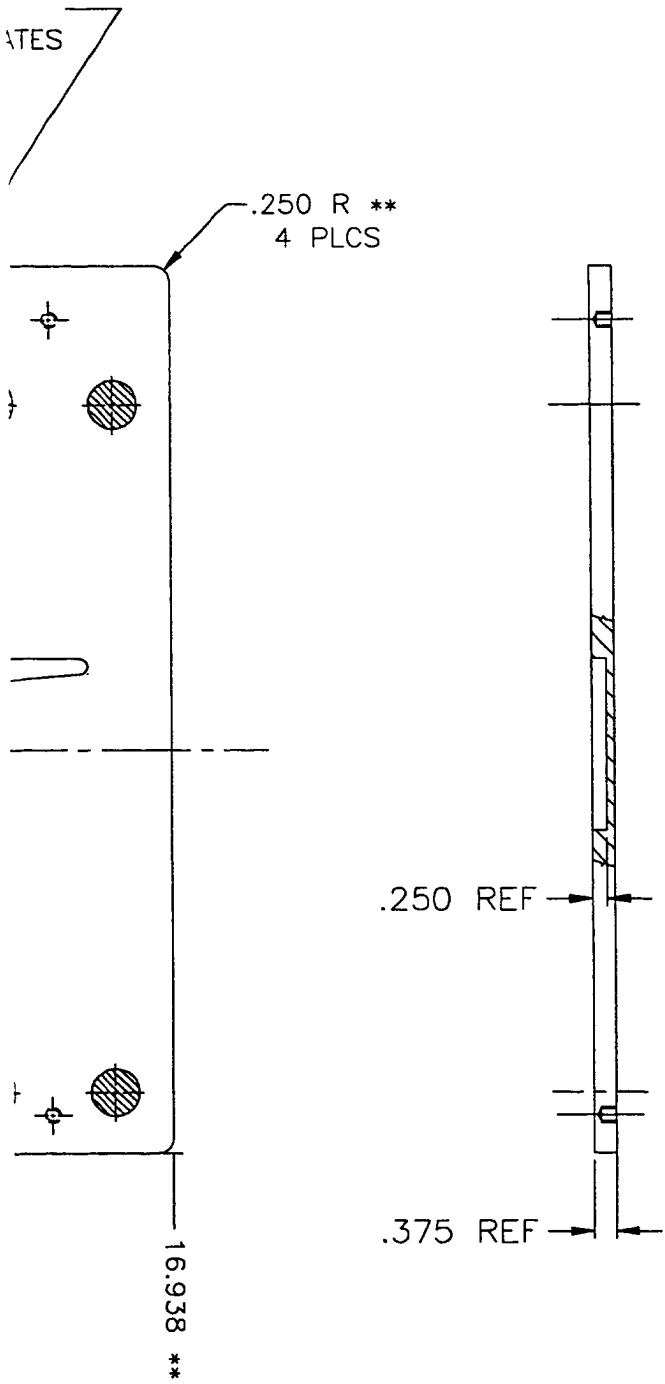
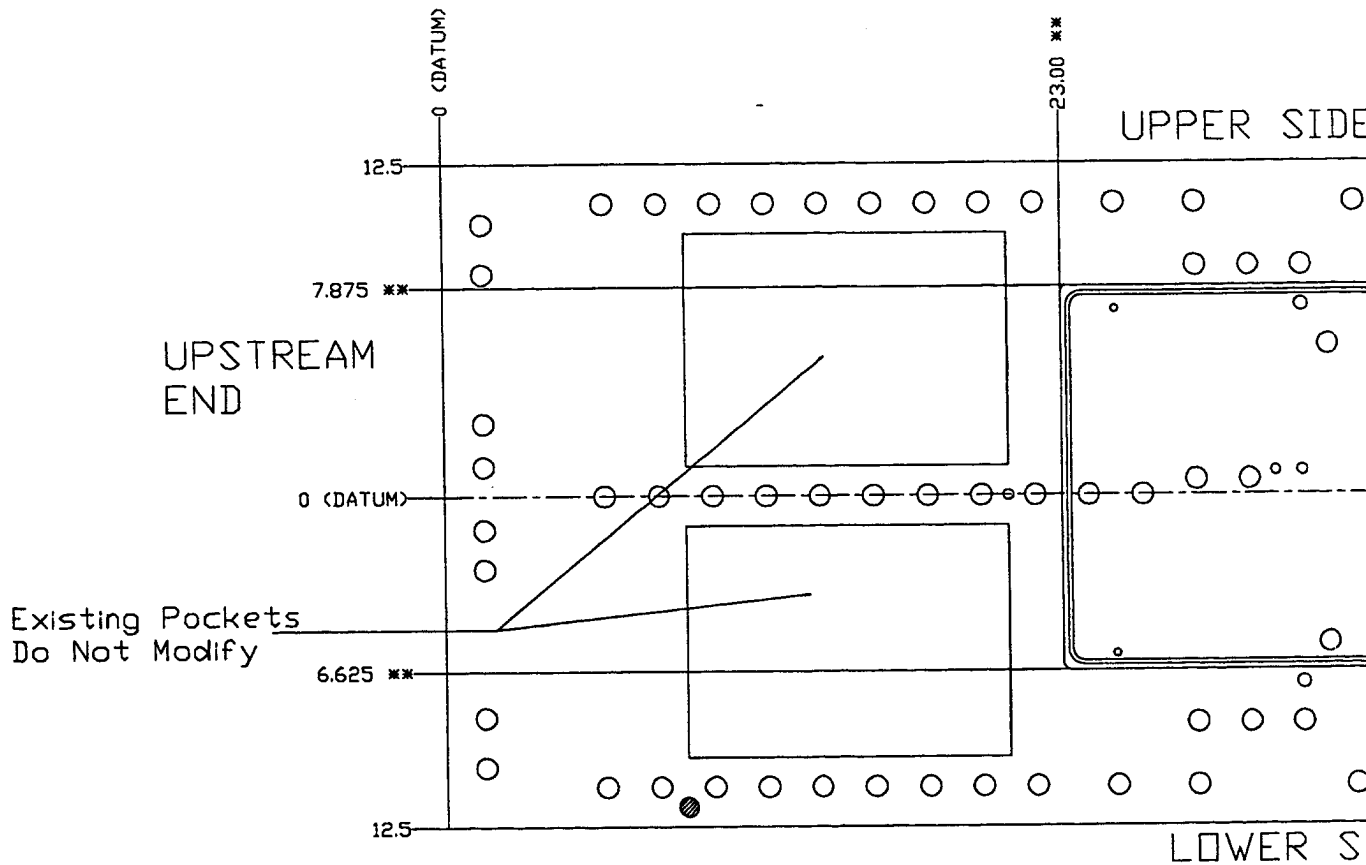
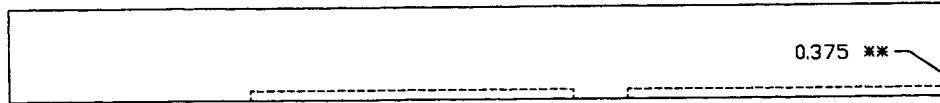
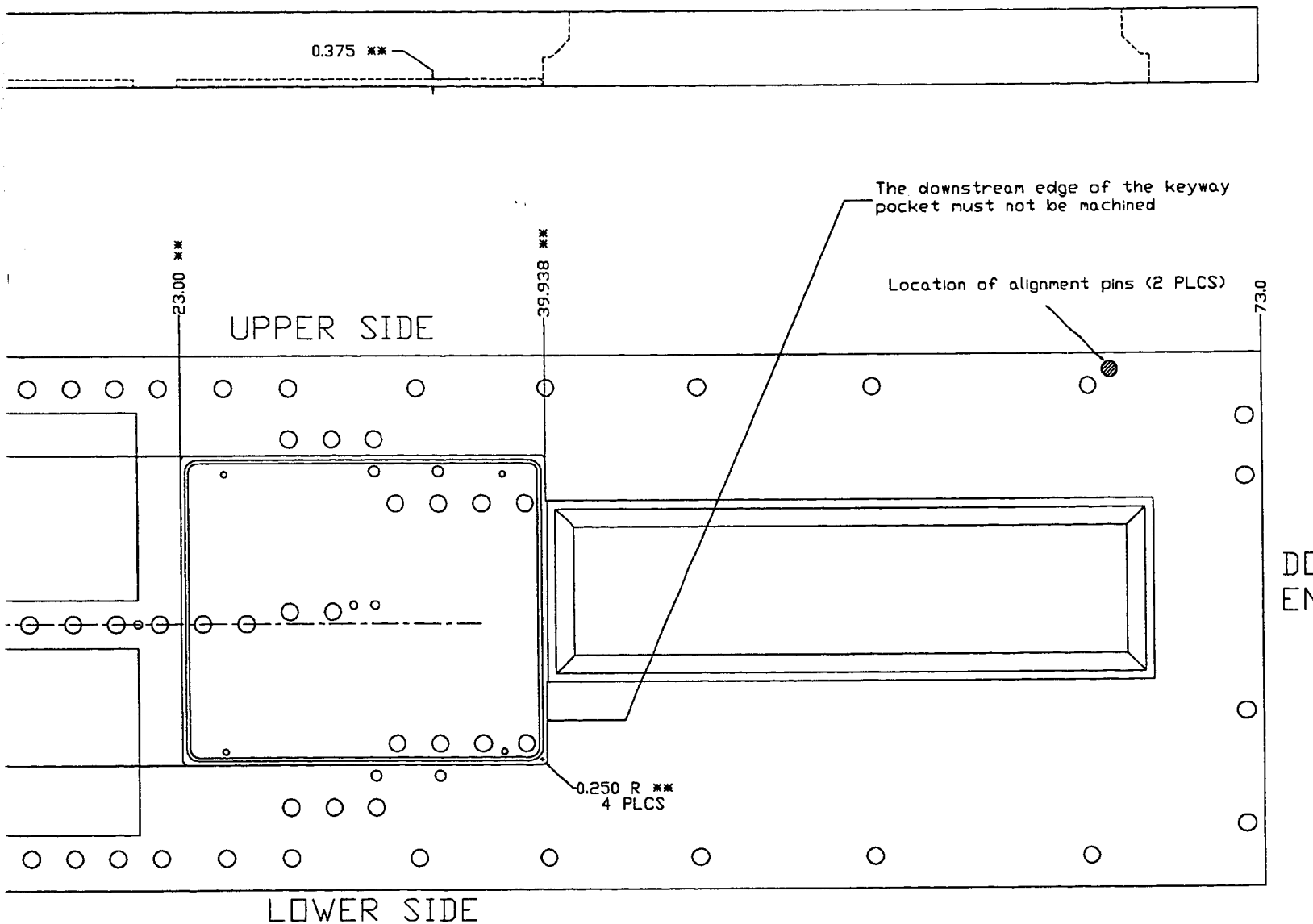

FIG. 5 The right-hand keyway insert: fabrication drawing

	15-5 PH COND. H900	2
DESCRIPTION	MATERIAL	ITEM
CALIFORNIA INSTITUTE OF TECHNOLOGY		
SCALE	1/4	
14 /94	TITLE R.H. KEYWAY TEST SECTION	DWG. NO. K-2A
		CHG.



\*\* These measurements are the nominal measurement position of these pockets may differ.



These are the nominal measurements of the existing keyway pockets. The actual size and locations of the keyway pockets may differ.

	SP-2	Existing Part		
REQ.	PART NO.	DESCRIPTION	MATERIAL	ITEM
SCALE = 1/10		CALIFORNIA INSTITUTE OF TECHNOLOGY SUPERSONIC SHEAR LAYER FACILITY		
DRAWN	CLB	7/26/94	TITLE	DWG. NO.
REVISED	CLB	8/2/94	R.H. SIDEPLATE	SP-2

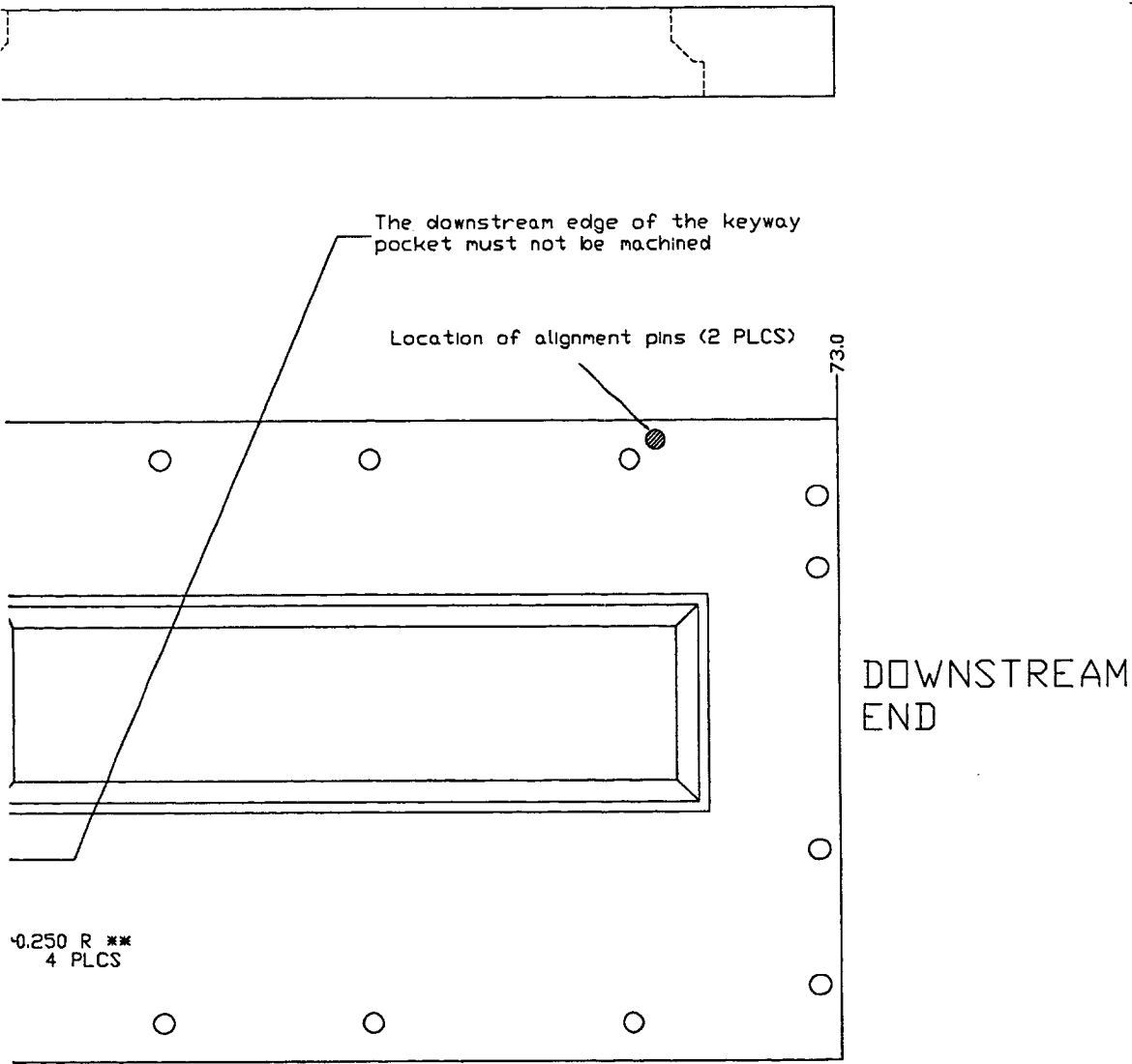

existing keyway pockets. The actual size and

FIG. 6 The right-hand sidewall: modification drawing

SP-2	Existing Part		
ITEM NO.	DESCRIPTION	MATERIAL	ITEM
1/10	CALIFORNIA INSTITUTE OF TECHNOLOGY SUPERSONIC SHEAR LAYER FACILITY		
B 7/26/94	TITLE	DWG. NO.	
B 8/2/94	R.H. SIDEPLATE	SP-2	

the sidewalls within 0.002" of a nominal position, producing the accurate alignment required for assembly of the splitter plate and keyway system.

These modifications to the Mk. I/II facility sidewalls required complete disassembly of the test section and transportation to a machine shop capable of performing precision work on large parts. Originally, the work was to have been done internally at Caltech, but the on-campus facilities proved incapable of meeting the new, tighter tolerances. As a result, estimates were solicited from twelve Southern California machine shops, experienced in similar work. Tri-Models, of Huntington Beach, California was selected to perform the machining described above, which has been successfully completed in the interim.

### 2.2.2 Plan-view optical access

In order to provide optical access to the plan view, *i.e.*, spanwise plane, of the shear layer flow, the top and bottom portions of the centerbody were modified to incorporate a window system. On both the top and bottom, a 2"-thick, BK-7 optical flat and a 1/8"-thick Pyrex sheet are held in a machined cavity by an aluminum clamping system. The Pyrex is used as sacrificial protection from the corrosive substances present in the test section for the costly, optical-quality BK-7 windows, in much the same fashion as it has been employed in the side-view windows (Hall & Dimotakis (1989)).

### 2.2.3 Other test-section modifications

Several other modifications were also made to the test section in the course of the second-stage upgrade. Access ports (1/2" NPT) were added to the inlet supply piping to the test section, providing the capability for the introduction of small amounts of (tracer) substances to each freestream and/or the addition of flow-monitoring instrumentation.

Two of these access ports were added to the length of pipe immediately upstream of the top freestream inlet flange. These ports are intended to house a thermocouple and provide access for tracer seeding. The thermocouple will be used to monitor the elevated top freestream stagnation temperature employed in the Mk. IV configuration. A single port was added to the bottom side freestream inlet flange, for the injection of tracers.

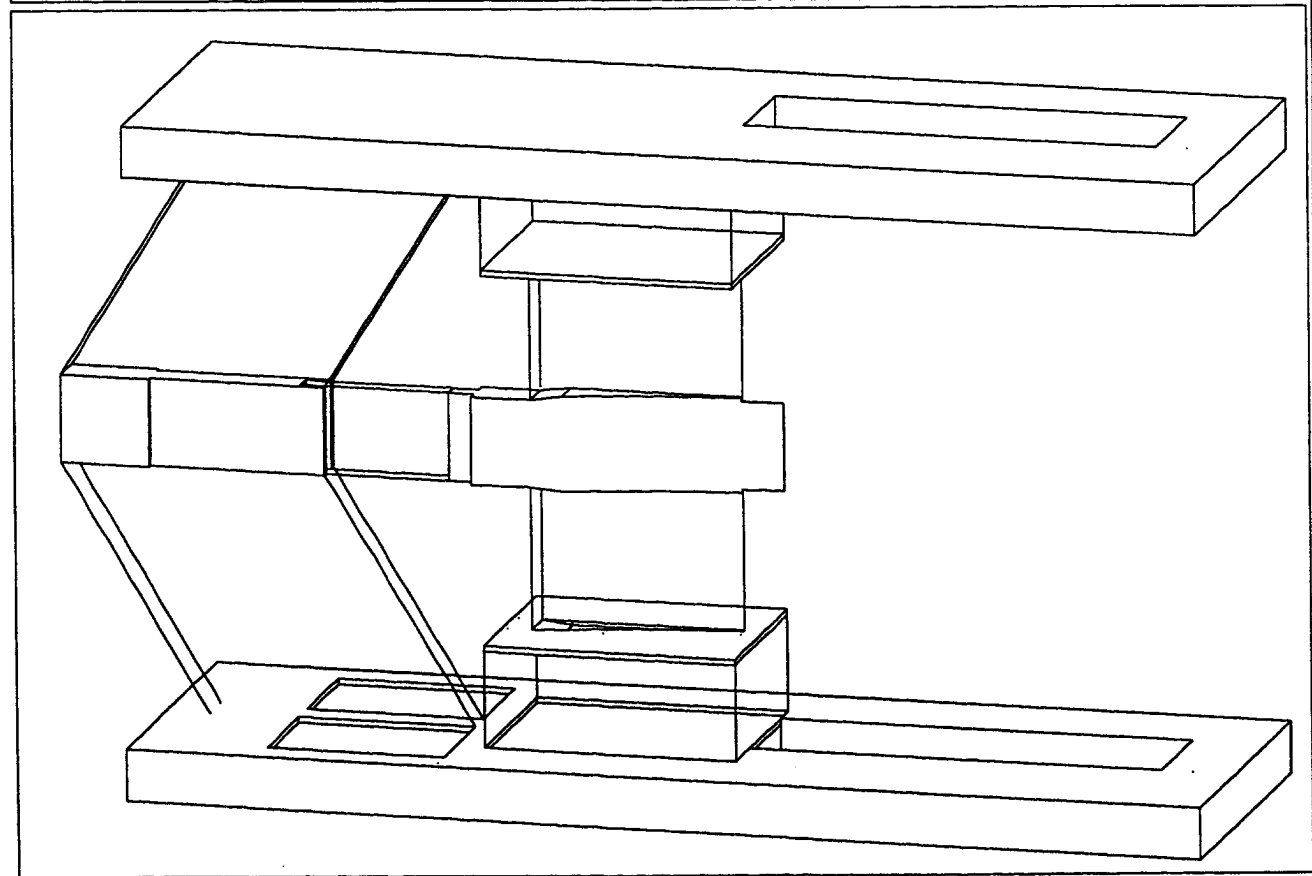
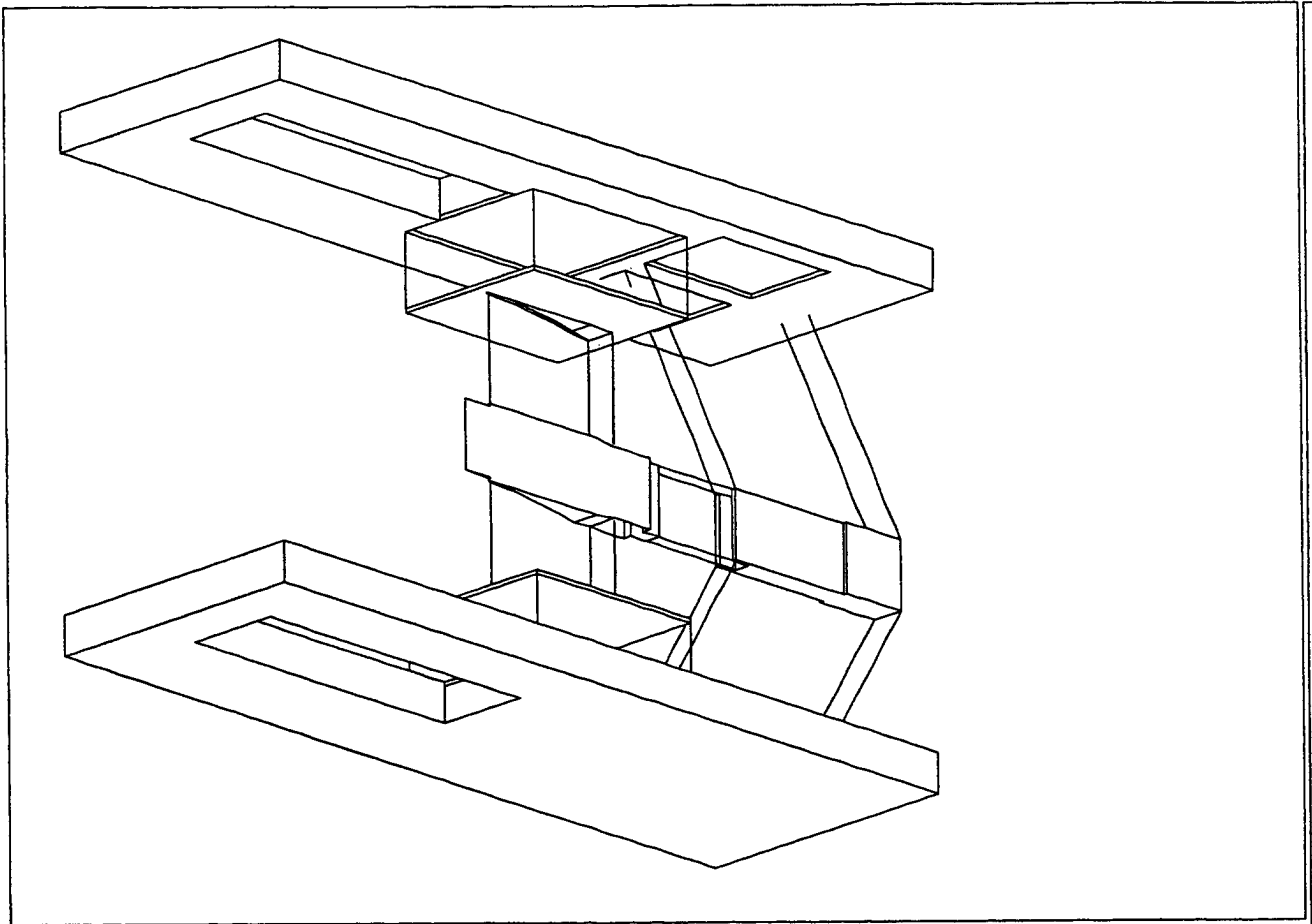

This view,  
Much  
The  
for

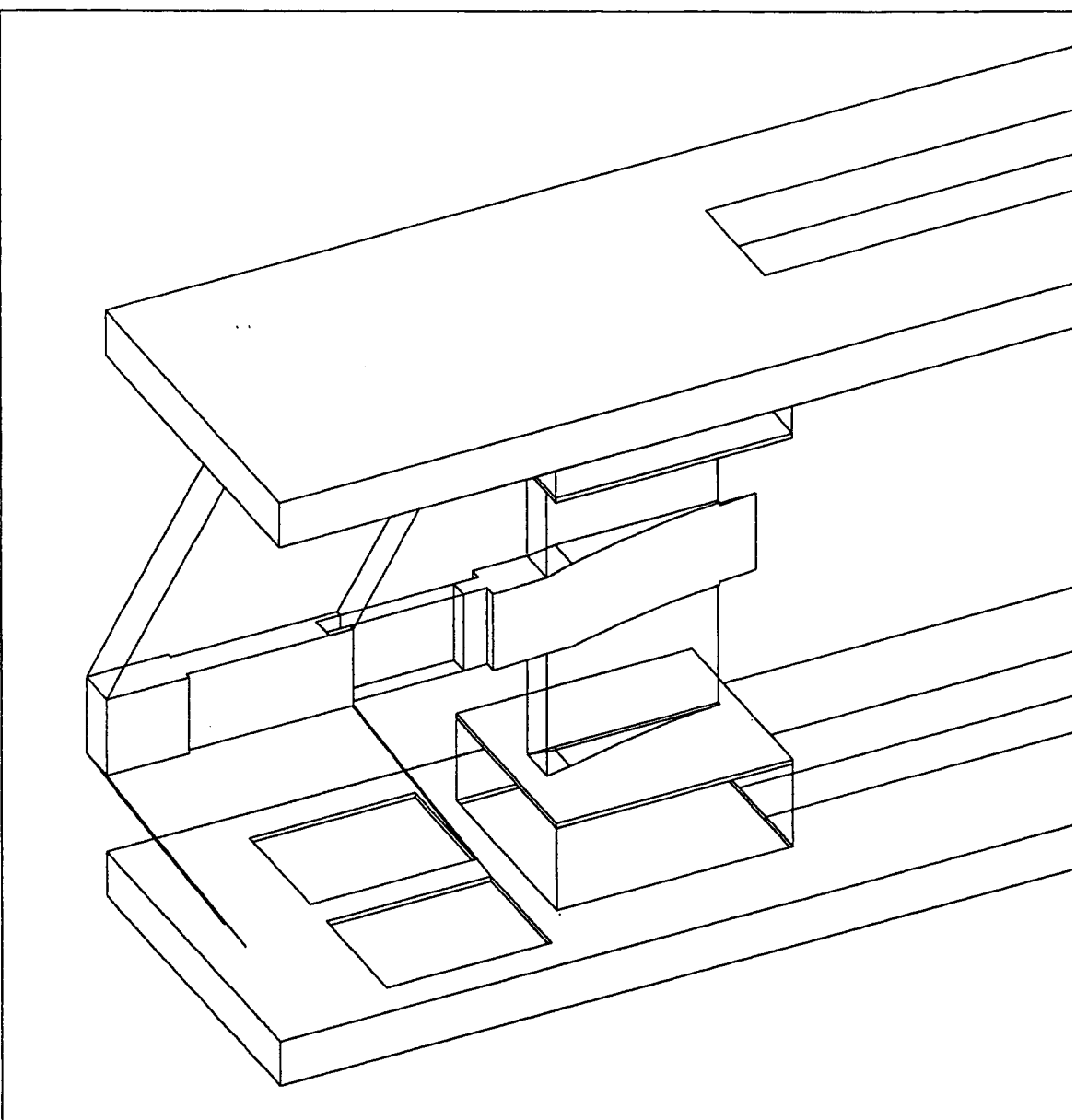
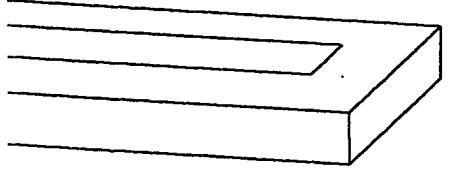
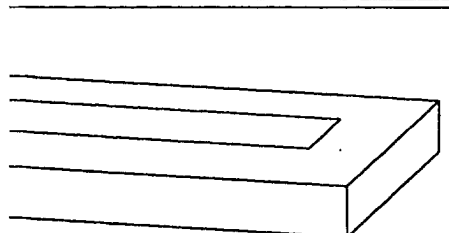

This drawing shows, from top to bottom view, parts SP-1, K-1, S-1 and C-1, K-2, and... Much detail has been omitted in favor of... The test section frame has also been... for clarity. See also Dwg. A-2.

REQ.	PART NO.	DESCRIPTION	MATERIAL
SCALE=VARIES		CALIFORNIA INSTITUTE OF SUPERSONIC SHEAR LAY	
DRAWN	CLB 7/27/94	TITLE ASSEMBLY DRAWING	
REVISED	CLB 8/2/94		

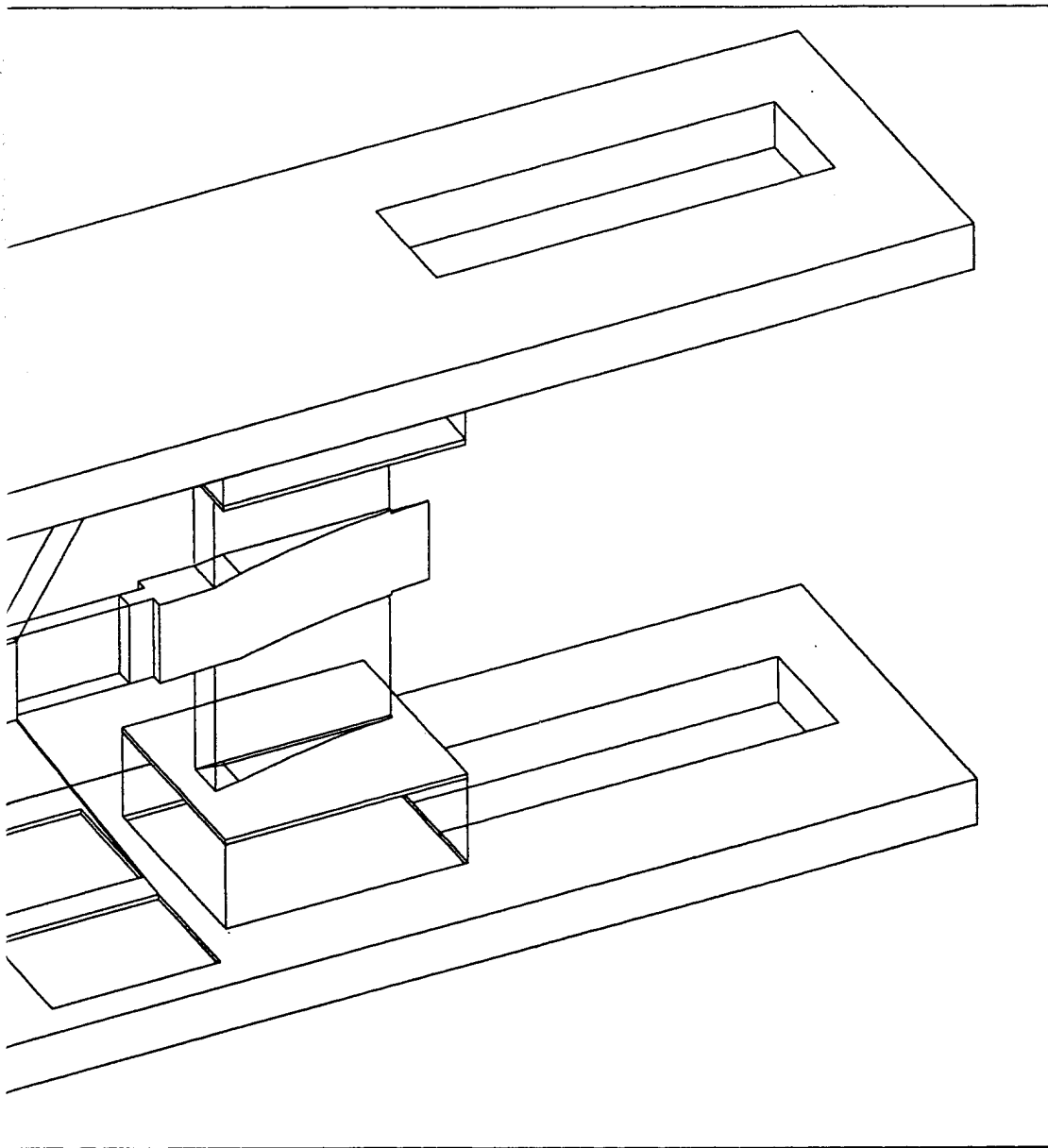

Fig. 7 Three-dimensional views of test section assembly

shows, from top to bottom in each SP-1,K-1,S-1 and C-1,K-2, and SP-2. has been omitted in favor of clarity. section frame has also been omitted See also Dwg. A-2.

REQ.	PART NO.	DESCRIPTION	MATERIAL	ITEM
SCALE=VARIES		CALIFORNIA INSTITUTE OF TECHNOLOGY SUPERSONIC SHEAR LAYER FACILITY		
DRAWN	CLB	7/27/94	TITLE	DWG. NO.
REVISED	CLB	8/2/94	ASSEMBLY DRAWING	A-1

### 2.2.4 Modifications to the top stream supply system

The top stream reactant tank pressure-relief system was redesigned to address several concerns and has subsequently been modified. The new system replaces the original, 4" diameter, burst diaphragm with a 1/2"-diameter burst diaphragm, followed by a pressure-relief valve. This diaphragm is thermally isolated from the reactant tank, to provide safe and reliable operation in the Mk. IV configuration. The relief valve is placed downstream of the burst diaphragm, is also thermally isolated as a consequence, and allows any over-pressure in the reactant tank, beyond the design limits of this vessel, to be vented without generating a shock wave, which might have damaged components in its exhaust path. Additionally, the pressure-relief valve in the new design will close after the tank pressure has fallen to below its set point, discharging a small amount of gas in the process and preventing the the entire contents of the high-pressure vessel to be exhausted in a time that would be very short. The reduced-diameter relief system (1/2" vs. 4") was the result of an internal design review, conducted in the process of the facility upgrade, in which it was decided that the original system was significantly larger than required and may have produced exhaust conditions beyond the capability of the original gas disposal system.

In the course of the test-section disassembly, much of the supply piping leading from the top stream reactant tank was removed. As part of the upgrade, the fasteners have been replaced with Grade B-7 fasteners, which provide more than adequate strength at the anticipated elevated temperatures. Therefore, much of the top stream supply system can now be heated to 600 K, as required for operation in the (future) Mk. IV configuration.

### 2.2.5 The gas-disposal catch bag

At the beginning of the upgrade to Mk. III status, the original catch bag, which holds the substances exhausted during a run, had reached the end of its specified four-year lifetime. The lifetime of the plastic laminate structure is specified by the manufacturer (Kepner Plastics of Torrance, California) and is primarily determined by exposure to ultraviolet radiation, *i.e.*, sunlight. A replacement bag, also manufactured by Kepner Plastics, has since been installed. The replacement catch bag has a larger volume than that of the original (5,400 ft<sup>3</sup>, vs. 4,000 ft<sup>3</sup>, respectively) and is capable of containing the exhaust gases at the highest freestream Mach number conditions attainable in this facility.

### 2.2.6 The gas-disposal catch bag enclosure

In order to upgrade the safety features of the S<sup>3</sup>L facility laboratory, an external enclosure for the catch bag was constructed. As previously discussed, this fire-proof enclosure serves to contain, monitor, and dispose any leaks from the catch bag; attenuate the considerable sound levels produced in high Mach number runs; and protect the bag from sunlight.

The constructed bag enclosure is a large (18'-high, 7.5'-deep, 32.5'-wide), stucco-exterior, steel-frame structure. Within the walls of the enclosure, fire-proof fiberglass insulation has been installed to provide (solar) heat insulation from the bag material and absorb the sound emitted from the facility when operating at high Mach number conditions. Two vertically-mounted, direct-drive, explosion-proof fans, each rated at 4,500 cfm, provide constant ventilation throughout the enclosure. These fans exhaust through a stack at the top of the enclosure, which extends 10' ( $\simeq$  3.3 m) above the roof of the adjacent building. This ventilation system is expected to remove any leaks, however unlikely, from the immediate vicinity of the laboratory and the surrounding structures and discharge them in the form of a momentum-dominated jet to substantially above the highest point in the building and, in particular, away from any of the building ventilation air intakes.

Two explosion-proof combustible-gas monitors are also mounted at the top of the enclosure, near the exhaust stack. These monitors, capable of detecting 400 ppm of H<sub>2</sub>, and comparable concentrations of other flammable gases, allow leaks in the catch bag to be detected. These monitors can also be used to detect leaks in the bag before reacting runs by filling it with a non-flammable mixture of H<sub>2</sub> and inert gases, *e.g.*, N<sub>2</sub>, He, Ar.

### 2.2.7 Gas-disposal catch bag shower system modifications

As part of the gas-disposal catch bag replacement, the showers which provide the scrubbing mixture of NaOH/H<sub>2</sub>O to the bag were inspected and replaced as required. Several shower heads were found to be clogged with fine particulates. A new filtering system has been installed to prevent similar problems in the future.

During construction of the enclosure, most of the supply plumbing for the shower system was removed so that the ground level could be surfaced with concrete. When replaced, this plumbing was upgraded for compatibility with the higher

scrubbing liquid temperatures expected during runs in the Mk. IV configuration. Additionally, an air-powered backup shower supply pump was installed, and the NaOH/H<sub>2</sub>O tanks were replaced. An air-powered pump, connected to a separate, compressed-air bottle, was selected as the backup system, to prevent a single-point failure in the unlikely event that electrical power is lost during the few seconds a run lasts.

### **2.3 Stage 3: Mk. III to Mk. IV transition**

As discussed above, as many of the elements that would have been required to allow the facility to attain Mk. IV status as feasible were included as part of the second-stage upgrade. As a consequence, we expect that this will permit the completion of the third-stage upgrade, to the Mk. IV configuration, within the calendar year. Nevertheless, a number of significant tasks must still be completed before Mk. IV-status operation can commence. Primarily, the top freestream supply tank and piping require the installation of the thermal system heaters and sensors, as well as insulation, to permit the temperature to be raised to as uniform a value along the extent of the top freestream supply system and to limit the heat transfer from the high-temperature system to the surrounding environment. Secondly, the heating elements sensors, and controllers need to be integrated into the system and thoroughly tested before high-pressure gas is introduced to the system. Finally, a set of high-temperature, but non-reacting runs are required as a test of the system before the chemically-reacting species are introduced to this environment.

### 3. References

- DIMOTAKIS, P. E. & LEONARD, A. 1994 "Chemical Reactions in Turbulent Mixing Flows," AFOSR F49620-92-J-0290 Final Technical Report (31 January 1995).
- HALL, J. L. 1991 *An Experimental Investigation of Structure, Mixing and Combustion in Compressible Turbulent Shear Layers*, Ph.D. thesis, California Institute of Technology.
- HALL, J. & DIMOTAKIS, P. E. 1989 "Design Overview of the Supersonic Hydrogen-Fluorine Facility (V4.0)," GALCIT Internal Report, 30 August 1989.
- MILLER, M. F., ISLAND, T. C., YIP, B., BOWMAN, C. T., MUNGAL, M. G. & HANSON, R. K. 1993 "An Experimental Study of the Structure of a Compressible Reacting Mixing Layer," 31st Aerospace Sciences Meeting and Exhibit, 11-14 Jan. 1993, Reno, NV.
- MUNGAL, M. G. 1983 *Experiments on Mixing and Combustion with Low Heat Release in a Turbulent Shear Flow*, Ph.D. thesis, California Institute of Technology.
- SLESSOR, M. D. & DIMOTAKIS, P. E. 1994 "Experiments on bi-supersonic turbulent shear layers," *Bull. Am. Phys. Soc.* **39**(9), 1880.