



**US Army Corps
of Engineers**
Waterways Experiment
Station

Technical Report REMR-CS-49
June 1995

Repair, Evaluation, Maintenance, and Rehabilitation Research Program

Applications of Precast Concrete in Repair and Replacement of Civil Works Structures

by *James E. McDonald, Nancy F. Curtis*

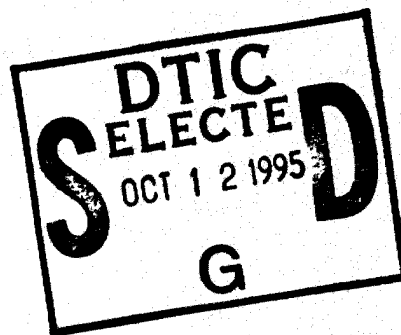

Approved For Public Release; Distribution Is Unlimited

19951011 016

DTIC QUALITY INSPECTED 5



Prepared for Headquarters, U.S. Army Corps of Engineers

The following two letters used as part of the number designating technical reports of research published under the Repair, Evaluation, Maintenance, and Rehabilitation (REMR) Research Program identify the problem area under which the report was prepared:

<u>Problem Area</u>		<u>Problem Area</u>	
CS	Concrete and Steel Structures	EM	Electrical and Mechanical
GT	Geotechnical	EI	Environmental Impacts
HY	Hydraulics	OM	Operations Management
CO	Coastal		

The contents of this report are not to be used for advertising, publication, or promotional purposes. Citation of trade names does not constitute an official endorsement or approval of the use of such commercial products.



PRINTED ON RECYCLED PAPER

Applications of Precast Concrete in Repair and Replacement of Civil Works Structures

by James E. McDonald, Nancy F. Curtis
U.S. Army Corps of Engineers
Waterways Experiment Station
3909 Halls Ferry Road
Vicksburg, MS 39180-6199

Accession For	
NTIS CRA&I	<input checked="" type="checkbox"/>
DTIC TAB	<input type="checkbox"/>
Unannounced	<input type="checkbox"/>
Justification	
By	
Distribution /	
Availability Codes	
Dist	Avail and/or Special
A-1	

Final report

Approved for public release; distribution is unlimited

Prepared for U.S. Army Corps of Engineers
Washington, DC 20314-1000

Under Work Unit 32636



**US Army Corps
of Engineers**
Waterways Experiment
Station

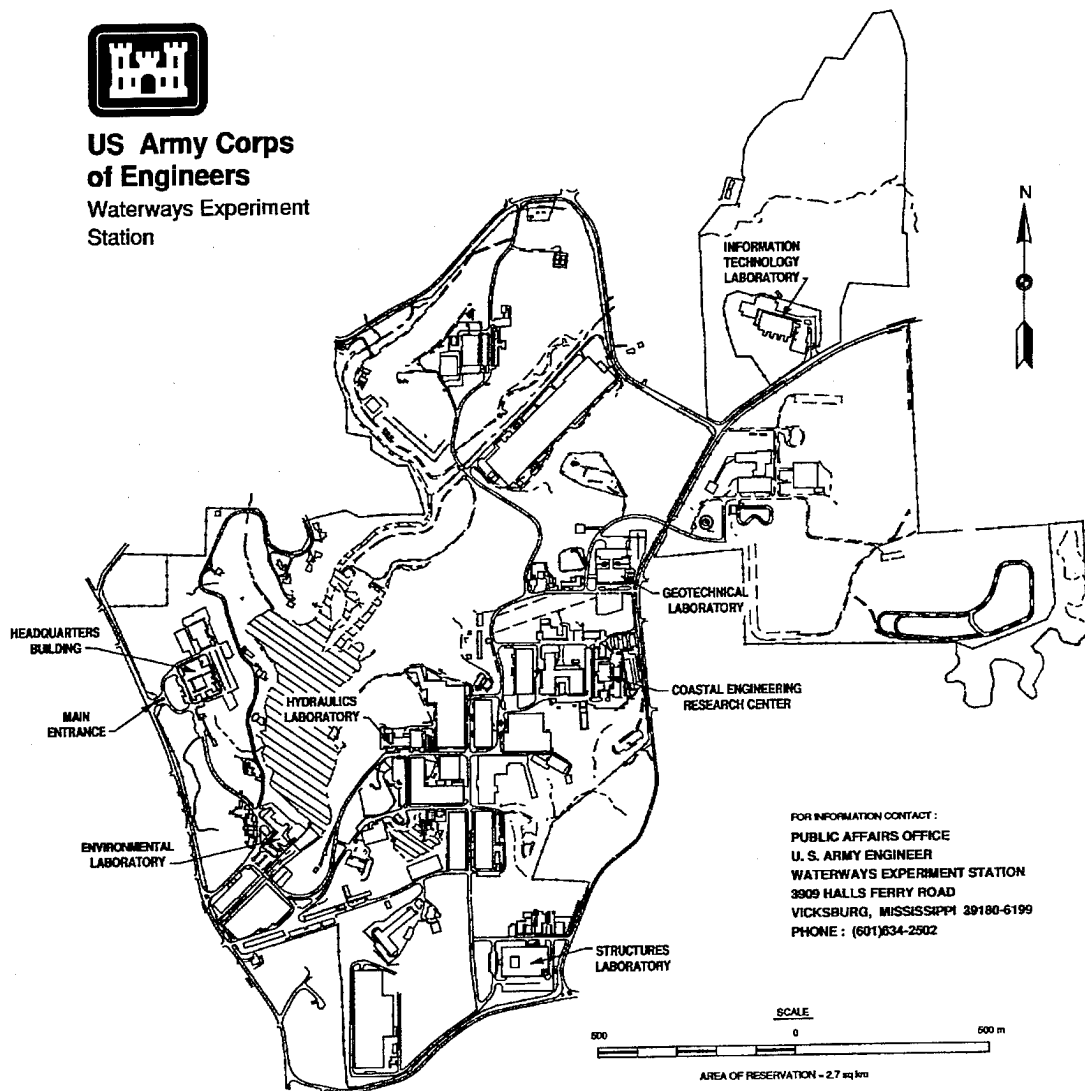

FOR INFORMATION CONTACT :
PUBLIC AFFAIRS OFFICE
U. S. ARMY ENGINEER
WATERWAYS EXPERIMENT STATION
3909 HALLS FERRY ROAD
VICKSBURG, MISSISSIPPI 39180-6199
PHONE : (601)634-2502

Waterways Experiment Station Cataloging-in-Publication Data

McDonald, J. E. (James E.)

Applications of precast concrete in repair and replacement of civil works structures / by James E. McDonald, Nancy F. Curtis ; prepared for U.S. Army Corps of Engineers.

298 p. : ill. ; 28 cm. — (Technical report ; REMR-CS-49)

Includes bibliographic references.

1. Precast concrete construction — Maintenance and repair. 2. Concrete construction — Maintenance and repair. 3. Public works — Maintenance and repair. 4. Precast concrete construction — Case studies — Analysis. I. Curtis, Nancy F. II. United States. Army. Corps of Engineers. III. U.S. Army Engineer Waterways Experiment Station. IV. Repair, Evaluation, Maintenance, and Rehabilitation Research Program. V. Title. VI. Series: Technical report (U.S. Army Engineer Waterways Experiment Station) ; REMR-CS-49.

TA7 W34 no.REMR-CS-49

Contents

Preface	xix
Conversion Factors, Non-SI to SI Units of Measurement	xx
1—Introduction	1
Background	1
Objective	1
Scope	2
2—Case Histories	3
Introduction	3
Navigation Locks	3
Lock 22	3
Troy Lock	11
Lockport Lock	24
Melvin Price Locks	27
Bonneville Lock	31
Dams	31
Barker Dam	32
Gibraltar Dam	37
Winchester Dam	38
Cuchillo Negro Dam	39
Northloop Flood Detention Dams	41
Gavins Point Dam	41
McClure Dam	46
Lake Sherburne Dam	47
Googong Dam	53
Blue Ridge Parkway Dams	60
Wilkerson Lake Dam	64
Vischer Ferry Dam	68
Chauncey Run Checkdams	71
C-1 Dam	73
Central and South Florida Flood Control Project	78
Fellows Lake Dam	84
Olmsted Dam	87
Deadwood Dam	88

Channels, Floodwalls, and Levees	91
Placer Creek Channel	91
Blue River Channel	93
Sydney Drainage Channels	96
El Dorado Flume	101
Mississippi River Channel	102
Mill Creek Channel	102
Joilet Channel Wall	104
West River Channel Wall	111
River des Peres Channel Wall	111
Bettendorf Floodwall	116
Hornell Floodwall	121
Pineville Floodwall	122
Chouteau Island Levee	125
Coastal and Offshore Structures	129
Fire Island Armor System	129
Skegness Shore Protection	131
Shell Island Erosion-Control System	131
Wallops Island Breakwater System	134
Avalon Beaches	136
Sargent Beach, Revetment	138
Pacifica Seawall	141
Cleveland Seawall	142
River Tawe Quay	143
Indian Ocean Reefs	144
Poole Bay Reefs	148
Newbiggin-by-the-Sea Protection Structures	149
Clyde Quay Wave Deflector	150
Chaffers Marina Floating Breakwater	152
New Zealand Salmon Raceways	153
Wallasey Cofferdam	155
Brandywine Shoal Lighthouse	158
Sydney Harbor	162
Corps of Engineers' Concrete Armor Systems	165
Roadway Bridges	165
Jediah Hill Covered Bridge	165
The Dublin Scioto Bridge	166
Maria Cristina Bridge	169
Rural Bridges in Oklahoma	171
Short-Span Bridges, Florida	174
The High Street Overhead	175
Woodrow Wilson Memorial Bridge	175
Fremont Street Bridge	181
The Fairbanks River Bridge	186
Connecticut and Chicopee River Bridges	187
Pennsylvania Turnpike	188
Krumkill Road	188
Kansas River Bridge	189
Ulsterville Bridge	189
The Colorado River	192

Wears Creek Bridge	193
Kent County Box-Arch Bridge	194
Pennsylvania Turnpike Median Barrier	197
Railroad Bridge Construction and Repair	198
The Santa Fe Railroad System	202
The Southern Pacific Railroad	205
Culverts and Tunnels	207
Minnesota	207
Fort Sill Army Base	207
North Dakota	208
New Jersey	209
Kentucky	209
Vancouver, B.C.	210
New York State Thruway	210
Holland Tunnel	211
St. Hubert Tunnel	212
Sumner Tunnel	213
Callahan Tunnel	215
Retaining Walls and Noise Barriers	216
Indianapolis Power & Light Company Coal Storage Facility	218
Massachusetts Shopping Mall	221
Pen-y-Clip Retaining Wall	223
Interstate Route 80, New Jersey	225
Kildonan Corridor Noise Attenuation Barrier	228
Precast Concrete Paving Blocks	231
Dallas-Fort Worth International Airport	232
Aberdeen Proving Ground	235
Ontario and North Carolina Study	238
3—Summary	242
Navigation Locks	242
Stay-in-place forms	242
Overlays	243
Guidewall units	244
Dams	245
Stay-in-place forms	245
Panel walls	246
Concrete mats	247
Gravity units and other components	248
Channels, Floodwalls, and Levees	249
Panels	249
Channel elements	251
Wall elements	252
Gatewell	253
Coastal and Offshore Structures	253
Modular armor systems	254
Erosion control systems	254
Precast panels	255
Artificial reefs	256

Precast components for berms, wave deflectors, and other components	256
Bridges, Culverts, and Tunnels	257
Aging structures	257
Short-span bridges	257
Precast concrete deck slabs	258
Bridge accoutrements	259
Railroad bridges	260
Culverts	260
Tunnels	261
Retaining Walls and Noise Barriers	262
Concrete Paving Blocks	264
4—Conclusions	266
References	268

List of Figures

Figure 1.	Typical condition of concrete prior to rehabilitation, Lock 22	4
Figure 2.	Typical lock wall repair section, Lock 22	6
Figure 3.	Condition of lock wall after removal of concrete. Precast panels on barges in lock chamber, Lock 22	7
Figure 4.	Panel installation, Lock 22	8
Figure 5.	Vertical alignment hardware, Lock 22	8
Figure 6.	Panel anchors welded to weld plates along top of panel, Lock 22	9
Figure 7.	Vertical expansion joint, Lock 22	9
Figure 8.	Precast panels and forms along bottom of panels in place and ready for placement of backfill grout, Lock 22	10
Figure 9.	Completed lock wall rehabilitation, Lock 22	12
Figure 10.	Typical ladder panel section, Troy Lock	14
Figure 11.	Panel storage in precast plant yard, Troy Lock	15
Figure 12.	Typical land wall repair section, Troy Lock	17

Figure 13.	Top of precast panel prior to placing infill concrete, Troy Lock	18
Figure 14.	Top of precast panel following placement of infill concrete, Troy Lock	18
Figure 15.	Heated enclosure for curing of infill concrete, Troy Lock	19
Figure 16.	Typical river wall repair section, Troy Lock	20
Figure 17.	River wall panel installation, Troy Lock	21
Figure 18.	Infill concrete placement and consolidation on river wall, Troy Lock	21
Figure 19.	Precast concrete panel installation completed, Troy Lock	23
Figure 20.	Typical cast-in-place concrete resurfacing of miter gate monoliths, Troy Lock	23
Figure 21.	Condition of river wall prior to repair, Lockport Lock	24
Figure 22.	Typical river wall section, Lockport Lock	25
Figure 23.	Precast base installation, Lockport Lock	26
Figure 24.	Placing precast panels, Lockport Lock	27
Figure 25.	Precast headcap installation at top of panels, Lockport Lock	28
Figure 26.	Completed river wall repair, Lockport Lock	28
Figure 27.	Precast concrete beams installed on downstream guidewall, Melvin Price Main Lock	29
Figure 28.	Offloading precast beams for Auxiliary Lock guidewall, Melvin Price Locks	30
Figure 29.	Precast concrete floating guidewall, Bonneville Lock . . .	31
Figure 30.	Upstream face of Barker Dam prior to rehabilitation . . .	32
Figure 31.	Footing and slab layout, south half of Barker Dam	34

Figure 32.	Portion of the upstream face of the Barker Dam with precast panels installed about three-fourths of its height	36
Figure 33.	RCC placement around lower drainage gallery panels, Gibraltar Dam	38
Figure 34.	Soldier beams being used to help position precast panels, Winchester Dam	40
Figure 35.	PVC-lined precast panels, Winchester Dam	40
Figure 36.	Rods used to anchor panels extend through bedding mixture into RCC, Winchester Dam	41
Figure 37.	Precast concrete stay-in-place forms on the upstream face of Cuchillo Negro Dam	42
Figure 38.	Typical cross section, Northloop Detection Dams	43
Figure 39.	Spall at draft tube portal, Gavins Point Dam	43
Figure 40.	Spall at south retaining wall, Gavins Point Dam	44
Figure 41.	Spall repair at draft tube portal, Gavins Point Dam	45
Figure 42.	Spall repair at south retaining wall, Gavins Point Dam	45
Figure 43.	Cross section of crest, McClure Dam	47
Figure 44.	Typical wall elevation and joint detail, McClure Dam	48
Figure 45.	Lake Sherburne Dam	49
Figure 46.	Conventional method of raising dam crest elevation, Lake Sherburne Dam	50
Figure 47.	Retaining wall method of raising dam crest elevation, Lake Sherburne Dam	51
Figure 48.	Cross section of Reinforced Earth retaining wall system, Lake Sherburne Dam	51
Figure 49.	Precast panels held in place by metal strips embedded in earth, Lake Sherburne Dam	53
Figure 50.	Lake Sherburne Dam following modifications	54

Figure 51.	Layout of dam and appurtenant structures, Googong Dam	55
Figure 52.	Typical section, Googong Dam modification	56
Figure 53.	Upstream and downstream footings for precast panels, Googong Dam	57
Figure 54.	First tier of panels, Googong Dam	58
Figure 55.	Precast panels clamped together during placement of granular fill, Googong Dam	59
Figure 56.	Schematic cutaway of cellular concrete mat system, Blue Ridge Parkway Dams	61
Figure 57.	CCM Anchor point and lateral seam between mats, Trout Lake Dam	63
Figure 58.	CCMs prior to placing topsoil cover, Trout Lake Dam	64
Figure 59.	Typical sections, Wilkerson Lake Dam	65
Figure 60.	CCM and geotextile filter fabric placed up to crest of dam, Wilkerson Lake Dam	67
Figure 61.	Placement of CCM along crest, Wilkerson Lake Dam	67
Figure 62.	Earth anchor installation on downstream slope, Wilkerson Lake Dam	68
Figure 63.	Completed CCM installation on crest of dam prior to placement of seeded topsoil, Wilkerson Lake Dam	69
Figure 64.	Plan and section view of precast pier nose, Vischer Ferry Dam	70
Figure 65.	Precast pier nose sections ready for installation, Vischer Ferry Dam	71
Figure 66.	Completed pier nose section, Vischer Ferry Dam	72
Figure 67.	Structural plan and elevation, Chauncey Run Checkdam No. 2	74
Figure 68.	Precast concrete checkdams, Chauncey Run, NY	75
Figure 69.	Isometric view of gate pier 6, C-1 Dam	76
Figure 70.	Precast nose unit, C-1 Dam	77

Figure 71.	Typical precast pier unit, C-1 Dam	77
Figure 72.	Positioning precast gate pier units, C-1 Dam	79
Figure 73.	Reinforcing for infill concrete, C-1 Dam	80
Figure 74.	Precast concrete gate piers, C-1 Dam	81
Figure 75.	Completed gate piers with gates installed, C-1 Dam	82
Figure 76.	Design details for precast concrete baffle blocks, S-65 and S-65A structures, Central and South Florida Flood Control Project	83
Figure 77.	Layout of Fellows Lake and Dam	85
Figure 78.	Precast concrete unit installed at Fellows Lake and Dam	86
Figure 79.	Concept for underwater installation of precast sill shells, Olmsted Dam	88
Figure 80.	Polymer concrete channel cladding, Deadwood Dam	90
Figure 81.	Parapet wall caps, Deadwood Dam	90
Figure 82.	Cracks at joints in parapet wall caps, Deadwood Dam	91
Figure 83.	Typical channel repair section, Placer Creek	92
Figure 84.	Cross section of precast low-flow channel, Blue River Channel	94
Figure 85.	Precast concrete low-flow sections, Blue River Channel	95
Figure 86.	Channel section delivery and installation, Blue River Channel	97
Figure 87.	Channel sections in place, Blue River Channel	98
Figure 88.	Diversion of river water through channel sections, Blue River Channel	99
Figure 89.	Precast box units, Sydney Drainage Channels	100
Figure 90.	L-shaped, precast channel units, Sydney Drainage Channels	101
Figure 91.	Precast concrete sections, El Dorado Flume	102

Figure 92.	Squares of precast concrete mats prior to sinking, Mississippi River	103
Figure 93.	Precast concrete mat-sinking operation, Mississippi River	103
Figure 94.	Typical concrete deterioration, Joliet Channel Wall	105
Figure 95.	Typical repair section, Joliet Channel Wall	106
Figure 96.	Footing detail, Joliet Channel Wall	107
Figure 97.	Placing insulation over first vapor barrier, Joliet Channel Wall	108
Figure 98.	Precast panels set into place on concrete footing, Joliet Channel Wall	109
Figure 99.	Joint detail, Joliet Channel Wall	110
Figure 100.	Top detail, Joliet Channel Wall	110
Figure 101.	Completed rehabilitation, Joliet Channel Wall	111
Figure 102.	Typical section, West River Channel Wall	112
Figure 103.	Completed project, West River Channel Wall	113
Figure 104.	Typical Doublewal precast concrete modules	114
Figure 105.	Typical precast concrete panels used in construction of mechanically stabilized backfill walls	115
Figure 106.	Lower wall section, Bettendorf Floodwall	117
Figure 107.	Typical wall section folded position, Bettendorf Floodwall	118
Figure 108.	Typical wall section with lower panel erected, Bettendorf Floodwall	119
Figure 109.	Typical wall section with upper and lower panels erected, Bettendorf Floodwall	120
Figure 110.	Precast cap detail, Hornell Floodwall	121
Figure 111.	Completed repair, Hornell Floodwall	123
Figure 112.	Closure structure, Pineville Levee and Floodwall	124

Figure 113.	Cross section showing sill beam installation, Pineville Levee and Floodwall	126
Figure 114.	Seal and deflector plate details, Pineville Levee and Floodwall	126
Figure 115.	Completed closure structure, Pineville Levee and Floodwall	127
Figure 116.	Two-section gateway, preassembled at precast yard, Chouteau Island Levee	128
Figure 117.	STA-PODS being used to help stabilize beach at Fire Island, New York	130
Figure 118.	STA-POD armor system applications	132
Figure 119.	Seabees being placed in an interlocking arrangement to prevent rock erosion on the sea defense slope at Skegness	133
Figure 120.	Beachcones arranged in triple pyramid	134
Figure 121.	Beachcones placed at Shell Island	135
Figure 122.	Beach Beam modules being installed for shoreline protection	135
Figure 123.	Typical precast concrete module used to create man-made reef	137
Figure 124.	Structure and effects of placement of Beachsaver reefs	137
Figure 125.	Beachsaver reefs being placed at Avalon Beach	138
Figure 126.	Typical cross section of concrete-block revetment for preventing erosion, Sargent Beach, Texas	140
Figure 127.	Precast tie-backs and panels used in seawall repair, California	142
Figure 128.	Rehabilitated Quayside Wall, River Tawe, Swansea	144
Figure 129.	Remaining rubble of a previously mined coral reef, Indian Ocean	145
Figure 130.	A SHED block, Indian Ocean	146
Figure 131.	Precast concrete cellular mattress, Indian Ocean	146

Figure 132.	Cellular mattress with transplanted coral, Indian Ocean	147
Figure 133.	Results of inspections of the artificial structures and control areas, Indian Ocean	148
Figure 134.	Cross section of sea-defense, coastal-protection structure at Newbiggin-by-the-Sea	150
Figure 135.	Precast units for lower berm, Newbiggin-by-the-Sea	151
Figure 136.	Completed section of lower berm, Newbiggin-by- the-Sea	151
Figure 137.	Precast wave deflector unit being placed by chain-block crane at Clyde Quay	152
Figure 138.	Precast concrete breakwater unit being towed to location at Chaffers Marina, New Zealand	154
Figure 139.	Completed precast concrete floating breakwater at Chaffers, New Zealand	154
Figure 140.	Smelt raceways at Southern Ocean Salmon. The walls are precast concrete tilt slabs	155
Figure 141.	Four precast units showing arrangement of columns, Wallasey Cofferdam	156
Figure 142.	Precasting sequences, Wallasey Cofferdam	157
Figure 143.	Erected units with lower joints grouted and temporary rock anchors installed, Wallasey Cofferdam	158
Figure 144.	Almost completed Wallasey Cofferdam	159
Figure 145.	Brandywine Lighthouse repairs	160
Figure 146.	First level precast concretes brackets, Brandywine Shoal Lighthouse	161
Figure 147.	Seawall beyond line of boardwalk at Pulpit Point, Australia	162
Figure 148.	Use of form liner to create visual interest at face of panel-flood-protecting wall	163
Figure 149.	Precast concrete units used to provide shore protection at Birchgrove	164

Figure 150.	Restoration plans for Jediah Hill Covered Bridge	166
Figure 151.	Dublin Scioto Bridge before rehabilitation	167
Figure 152.	Panel prestressing layout, Dublin Scioto Bridge	168
Figure 153.	Details of panel reinforcing for Dublin Scioto Bridge . . .	168
Figure 154.	Precast panel placement, Dublin Scioto Bridge	169
Figure 155.	Dublin Scioto Bridge after rehabilitation	170
Figure 156.	Details of transverse and longitudinal sections, Maria Christina Bridge	172
Figure 157.	Cross section of precast beam showing placement of steel reinforcing in short-span bridge	173
Figure 158.	Materials list for construction of two sets of forms for short-span bridges	174
Figure 159.	Panels for High Street Overhead were cast in right-of-way at jobsite	176
Figure 160.	Woodrow Wilson Memorial Bridge, a major traffic area for Washington, D.C., and surrounding areas	176
Figure 161.	Barrier relocated at night so work on the Woodrow Wilson Memorial Bridge could continue	177
Figure 162.	Bearing assembly, Woodrow Wilson Memorial Bridge . .	178
Figure 163.	Painted steel and forms for bearing pads placed on stringers in section where concrete has been removed, Woodrow Wilson Memorial Bridge	178
Figure 164.	Space between anchor panels allows for post- tensioning, Woodrow Wilson Memorial Bridge	180
Figure 165.	Typical segment joint, Woodrow Wilson Memorial Bridge	180
Figure 166.	Steel expansion joint assembly, Woodrow Wilson Memorial Bridge	181
Figure 167.	North elevation of Fremont Street Bridge	182
Figure 168.	Traffic lanes on one-half the Fremont Street Bridge were kept open during construction	183

Figure 169.	Cross section showing the floor-beam column bent for the Fremont Street Bridge	183
Figure 170.	Details of a floor-beam-to-column connection with a two-piece prestressed bar assembly, Fremont Street Bridge	184
Figure 171.	Layout of deck section with 10 precast slabs post-tensioned transversely, Fremont Street Bridge	185
Figure 172.	Detail of female shear key, Fremont Street Bridge	185
Figure 173.	Sketch showing location of leveling bolts and posttensioning ducts, Fremont Street Bridge	186
Figure 174.	Workers placing a precast edge panel with a safety parapet on the Kansas River Bridge	189
Figure 175.	Brackets attached to girders provide temporary support, Kansas River Bridge	190
Figure 176.	Top view of precast abutment prior to backfilling, Ulsterville Bridge	191
Figure 177.	Front view of precast abutment prior to placing concrete cap, Ulsterville Bridge	191
Figure 178.	Precast abutment and deck units, Ulsterville Bridge	192
Figure 179.	Precast arch sections being installed at Wears Creek	194
Figure 180.	Plan of precast arch-box end section. Headwall is cast as part of the section; precast wingwall is attached during installation	195
Figure 181.	Cast-in-place footing with shims installed for Kent County bridge construction	195
Figure 182.	Precast arch-box units being placed at Kent County bridge	196
Figure 183.	Joint wrap being applied to precast arch-box sections, Kent County	196
Figure 184.	Steel reinforcing forms an arch over inflatable forms used for jobsite precasting arch sections for bridges	197
Figure 185.	Cross section of precast concrete shell median barrier on Pennsylvania Turnpike	198

Figure 186.	Cross section of anchoring system for precast concrete barrier shell on Pennsylvania Turnpike	199
Figure 187.	Precast, reinforced-concrete T-girder stored beside track until needed	200
Figure 188.	Precast concrete pile caps for replacement spans beneath timber trestle	201
Figure 189.	Shear keys between box girders are filled with pea gravel and epoxy	201
Figure 190.	Corrosion of the top flange of a girder on the Santa Fe Railroad	202
Figure 191.	High-strength strands are pulled the length of the casting bed and tensioned with a hydraulic jacking system	203
Figure 192.	A bottom mat of mild steel reinforcing is tied to the strands of the Santa Fe Railroad	203
Figure 193.	Sand-epoxy grout was used to fill traverse joints between the slabs on the Santa Fe Railroad redecking	204
Figure 194.	Interior box girders placed on piers during Southern Pacific bridge replacement	206
Figure 195.	Precast 30-ft box girder approach span on precast bolster blocks, Southern Pacific Railroad	207
Figure 196.	Precast concrete box culvert, Minnesota	208
Figure 197.	Ceiling replacement design for Holland Tunnel	212
Figure 198.	Double arch tunnel system to be used in St. Hubert Tunnel	213
Figure 199.	Cross section of plan for rehabilitation of Sumner Tunnel, Boston	214
Figure 200.	Details of anchoring system for precast polymer concrete panels used in Sumner Tunnel, Boston	215
Figure 201.	A reflective acoustic barrier made of Hollowcore planks	217
Figure 202.	A dispersive acoustic barrier	217
Figure 203.	An absorptive acoustic barrier	218

Figure 204.	Precast concrete wall covered with absorptive material to create an absorptive acoustic barrier	218
Figure 205.	Diagram of Indiana Power & Light coal storage area	219
Figure 206.	Typical precast panel section for Wall A at Indiana Power & Light coal storage facility	220
Figure 207.	Typical precast panel section for Wall B at Indiana Power & Light coal storage facility	221
Figure 208.	Design for retaining-wall system used for shopping mall in Massachusetts; this wall supports panels to 16 ft high	222
Figure 209.	Close-up of the precast concrete panel wall at Pen-y-Clip Tunnel	224
Figure 210.	Precast concrete panel retaining wall at Pen-y-Clip Tunnel	225
Figure 211.	Section of precast concrete post and panel noise barrier wall installed along Interstate Route 80, New Jersey	226
Figure 212.	Concrete and steel structure used to support precast concrete panels along bridges on New Jersey Interstate Route 80	227
Figure 213.	Precast I-shaped posts and panels used to form noise barrier wall along New Jersey Interstate Route 80	228
Figure 214.	Precast concrete noise barrier with murals, Winnipeg, Canada	229
Figure 215.	Drawing that shows how columns were anchored to pile caps, Winnipeg	230
Figure 216.	Top view of panel-to-column installation of noise barrier, Winnipeg	231
Figure 217.	Completed precast concrete noise barrier with safety barrier and landscaping at Winnipeg, Canada	231
Figure 218.	Cross section of typical block pavement	233
Figure 219.	Examples of paving-block shapes	233

Figure 220.	Cross section of base for concrete paving blocks at Dallas Fort Worth International Airport	234
Figure 221.	Concrete paving blocks placed in herringbone pattern on taxiways at Dallas Fort Worth International Airport . .	235
Figure 222.	Intersection at Aberdeen Proving Ground before installation of concrete block pavement	236
Figure 223.	Fill being placed over geotextile fabric at Aberdeen Proving Ground	237
Figure 224.	Concrete paving blocks being placed by hand at Aberdeen Proving Ground	237
Figure 225.	Plate compactor being used to vibrate jointing sand into paving block joints at Aberdeen Proving Ground . . .	239
Figure 226.	An M-88 Tank Retriever tests the newly installed concrete block pavement at Aberdeen Proving Ground . .	239
Figure 227.	Close-up of concrete block pavement at Aberdeen Proving Ground after 1 year of service	240
Figure 228.	Precast concrete paving blocks on streets and sidewalks in North Bay, Ontario	240

Preface

The study reported herein was authorized by Headquarters, U.S. Army Corps of Engineers (HQUSACE), under Civil Works Research Work Unit 32636, "New Concepts in Maintenance and Repair of Concrete Structures," for which Mr. James E. McDonald, Structures Laboratory (SL), U.S. Army Engineer Waterways Experiment Station (WES), is the Principal Investigator. This work unit is part of the Concrete and Steel Structures Problem Area of the Repair, Evaluation, Maintenance, and Rehabilitation (REMR) Research Program.

The REMR Technical Monitor is Dr. Tony C. Liu, HQUSACE. Mr. William N. Rushing (CERD-C) is the REMR Coordinator at the Directorate of Research and Development, HQUSACE. Mr. James E. Crews (CECW-O) and Dr. Liu (CECW-EG) serve as the REMR Overview Committee. Mr. Williams F. McCleese, WES, is the REMR Program Manager. Mr. McDonald is the Problem Area Leader for Concrete and Steel Structures. This report was prepared by Mr. McDonald, Concrete Technology Division (CTD), SL, and Ms. Nancy F. Curtis, Contractor, under the general supervision of Mr. McCleese, Acting Chief, CTD; and Mr. Bryant Mather, Director, SL.

The authors would like to acknowledge the assistance of the following individuals who provided information for this report:

Mr. Kenneth P. Allen, Bergmann Associates, Rochester, NY
Mr. Ben Foreman, U.S. Army Engineer District (USAED), Savannah
Mr. Morris E. Ganaden, USAED, Kansas City
Mr. Norman J. Himsley, NSW Dams Safety Committee, Parramatta, Australia
Mr. William R. Miles, Bergmann Associates, Rochester, NY
Mr. George R. Powledge, GEI Consultants, Inc., Englewood, CO
Mr. Todd Rutenbeck, Bureau of Reclamation, Denver, CO
Mr. Peter J. Smith, The Fort Miller Co., Inc., Schuylerville, NY
Mr. Jerry Wickersham, USAED, Rock Island

At the time of publication of this report, Director of WES was Dr. Robert W. Whalin. Commander was COL Bruce K. Howard, EN.

The contents of this report are not to be used for advertising, publication, or promotional purposes. Citation of trade names does not constitute an official endorsement or approval of the use of such commercial products.

Conversion Factors, Non-SI to SI Units of Measurement

Non-SI units of measurement used in this report can be converted to SI units as follows:

Multiply	By	To Obtain
acres	4,046.873	square metres
acre-feet	1,233.489	cubic metres
cubic feet	0.02831685	cubic metres
cubic yards	0.7645549	cubic metres
degrees (angle)	0.01745329	radians
Fahrenheit degrees	5/9	Degrees Celsius or kelvins ¹
feet	0.3048	metres
gallons (US liquid)	3.785412	litres
horsepower (550 foot-pounds (force) per second)	745.6999	watts
inches	25.4	millimetres
kips (force)	4.448222	kilonewtons
kips (force) per square inch	6.894757	megapascals
miles	1.609347	kilometres
pints (US liquid)	0.4731765	litres
pounds (mass)	0.4535924	kilograms
pounds (force) per square inch	0.006894757	megapascals
pounds (mass) per cubic foot	16.01846	kilograms per cubic metre
pounds (mass) per cubic yard	0.5932764	kilograms per cubic metre
pounds (force) per square foot	47.88026	pascals
pounds (mass) per square yard	0.542492	kilograms per square metre
square feet	0.09290304	square metres
square yards	0.8361274	square metres
tons (force)	8.896444	kilonewtons
tons (mass)	907.1847	kilograms

¹ To obtain Celsius (C) temperature readings from Fahrenheit (F) readings, use the following formula: $C = (5/9)(F - 32)$. To obtain kelvin (K) readings, use $K = (5/9)(F - 32) + 273.15$.

1 Introduction

Background

A precast concrete stay-in-place forming system for lock wall rehabilitation was designed and demonstrated as part of the original Repair, Evaluation, Maintenance, and Rehabilitation (REMR) Research Program. This system has been used successfully by the Corps of Engineers and the private sector to rehabilitate a number of navigation lock structures including Lock 22, Mississippi River; Troy Lock, Hudson River; and Lock O-6, Oswego Canal. In each case, precast concrete proved to be an expedient and economical repair system.

Applications of precast concrete in rehabilitation of navigation locks have demonstrated that compared with cast-in-place concrete, precasting offers a number of advantages including minimal cracking, ease of construction, rapid construction, improved appearance, and future maintenance costs are expected to be low. Also, precasting minimizes the impact of adverse winter weather. Recent bid prices indicate that the cost of precast concrete is similar to that for cast-in-place concrete. However, as the number of qualified precast suppliers continues to increase and as contractors become more familiar with the advantages of precast concrete, it is anticipated that the costs of precast concrete will be reduced. Consequently, current REMR research is directed toward development of additional applications for precast concrete in repair or replacement of civil works structures. Case histories of precast concrete applications in repair or replacement of navigation locks, dams, channels, floodwalls, levees, coastal structures, marine structures, bridges, culverts, tunnels, retaining walls, noise barriers, and highway pavement are included in this report.

Objective

The objective of this study was to develop, review, and analyze selected case histories involving applications of precast concrete in repair or replacement of civil works structures.

Scope

Input on applications of precast concrete in repair of Corps structures was solicited by a letter from the principal investigator to each Division and District office. Information obtained from the responding offices varied widely in content and detail. The information was checked for completeness, and in some cases, follow-up contact was made to obtain missing data or to clarify information. Additional information on applications of precast concrete in repair or replacement of civil works structures was obtained through (a) literature searches; (b) discussions with designers, precasters, and contractors; (c) visits to project sites; and (d) discussions with project personnel.

The information available from the various sources differed widely; however, attempts were made to obtain (a) a description of the project, (b) the cause and extent of the deficiency that necessitated repair or replacement, (c) design details, (d) descriptions of materials and precasting procedures, (e) construction techniques, (f) costs, and (g) performance to date of the precast concrete. Case histories were prepared for those projects where sufficient information was obtained. Based on a review and analysis of these case histories, recommendations for future applications of precast concrete were developed, and areas which could benefit from research were identified.

2 Case Histories

Introduction

Precast concrete has been used in repair or replacement of a wide variety of civil works structures. The case histories reported herein are generally grouped according to either the type of structure (locks, dams, bridges, etc.) or the intended function of the precast concrete (erosion control, noise barriers, etc.).

Navigation Locks

Precast concrete panels were used as stay-in-place forming systems for resurfacing of the lock chambers at Lock 22, Mississippi River, and Troy Lock, Hudson River. Also, precast concrete panels were used as rigid overlays on the back side of the river walls at Lockport Lock, Illinois Waterway, and Troy Lock. These overlays were used in lieu of deteriorated concrete removal and replacement. Large precast concrete sections were used in construction of guidewalls at Melvin Price Locks, Mississippi River, and Bonneville Lock, Columbia River.

Lock 22

Lock and Dam 22 is located on the Mississippi River downstream from Hannibal, MO. The lock is 110 ft wide and 600 ft¹ long with a 10.5-ft lift. The lock was constructed during the early 1930's.

In 1986, the Rock Island District performed a condition survey of the lock and dam that included a review of the construction history, a comprehensive visual examination, sounding the surfaces with a steel hammer, and a coring and testing program. Cracks, drummy areas, and other distresses were noted on sketches to determine the areal extent of the deterioration. A megascopic and a petrographic examination of the cores provided information on the depth

¹ A table of factors for converting non-SI units of measurement to SI units is presented on p xx.

and cause of the deterioration. Results of compressive strength tests were used to evaluate the quality of the underlying concrete.

The findings of the condition survey are summarized as follows: the lock was constructed before the common usage of intentionally air-entrained concrete; there were extensive areas of deteriorated concrete as a result of 50 plus years of cycles of freezing and thawing and impact and abrasion from barges and ice. In general, the deterioration extended about 10 ft down from the top of the lock wall and was approximately 6 in. deep in localized areas (Figure 1). The compressive strength of the underlying concrete averaged 6,180 psi, indicating its strength and quality were satisfactory. The recommended method of repair was to remove and replace the deteriorated concrete with air-entrained concrete.

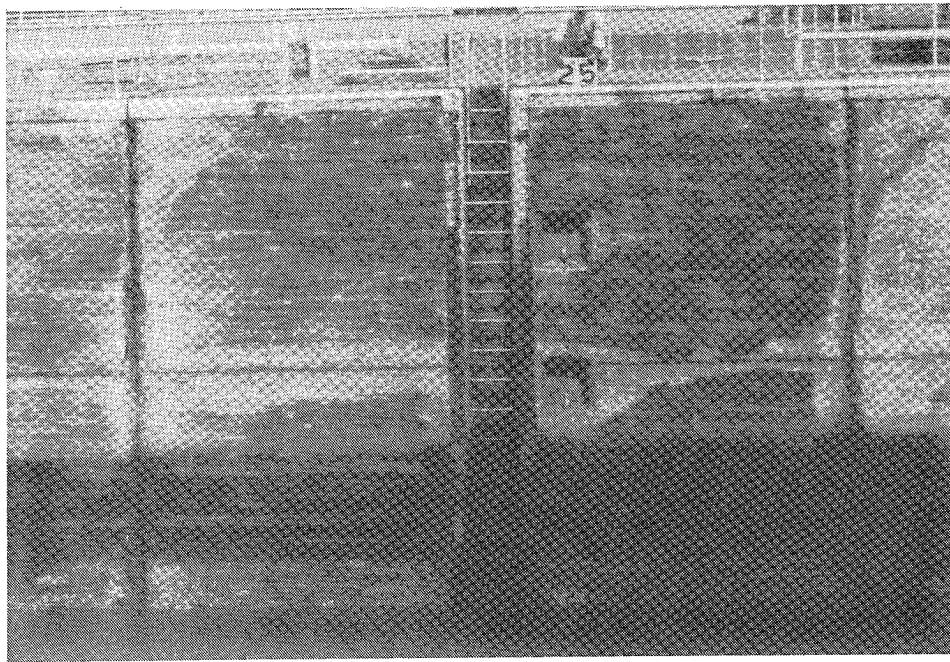

Figure 1. Typical condition of concrete prior to rehabilitation, Lock 22

Several factors had to be considered in the selection of a repair method:

- (a) Lock walls repaired with conventional cast-in-place concrete have had recurring problems with thermal and shrinkage cracking of the new concrete.
- (b) The repair would have to be accomplished during a short, 60-day shut-down period.
- (c) The lock wall repairs would have to be integrated with other required work, such as installation of bulkheads and the poiree dam, dewatering of the lock, removal of silt and debris from the bottom of the lock, removal and replacement of concrete around the miter gates and within the chamber, repair of the upper and lower guide walls, and replacement of the lock's electrical and mechanical systems. To keep disruption of navigation to a minimum, workers would have to perform the repair during January and February when the weather is cold.

A precast concrete stay-in-place forming system for lock wall rehabilitation, developed as part of the original REMR program (ABAM 1987a and 1987b, McDonald 1987a), offered several advantages over conventional repair with cast-in-place concrete. Those advantages included a reduction of cracking in the replacement concrete, a reduction in cold-weather concrete-placement costs, and a reduction of the shutdown period. The precast-panel method of repair was selected because of these advantages.

The repairs extended 13 ft down from the top of the lock wall (Figure 2). The lower 10.5 ft of the lock wall was to be repaired with precast panels; the upper 2.5 ft, with cast-in-place concrete. The general construction procedure included removal of concrete, fabrication of panels, installation of anchors, setting and alignment of panels, and filling the void between the lock wall and the precast panel.

Concrete removal began with an 8.5-in.-deep sawcut at the bottom of the repairs. Line drilling, which was accomplished prior to shutdown, and blasting techniques were used to remove from 8.5 to about 10.5 in. of concrete from the face of the lock walls. There were some areas of overbreak below the 8.5-in.-deep sawcut. Final cleanup was accomplished with hand-held chipping hammers, wet sandblasting, and a final wash with water (Figure 3).

The precast panels were fabricated about 200 river-miles upstream. Each panel was 10.5 ft high by 6.5 in. thick. Panel lengths ranged from 19 to 35 ft; however, most panels were 30 ft long. The length of the panels was matched to the existing monolith joints in the lock wall. The precast panels were reinforced as shown in Figure 2. Other embedded items included weld plates on 2-ft centers at the top and bottom of the panel, leveling inserts on 5-ft centers along the bottom, and stripping and erection handles. Two sets of forms were used; a total of 41 panels were cast in approximately 50 calendar days.

An air-entrained concrete mixture proportioned for a compressive strength of 6,500 psi at 28 days was used to precast the panels. The concrete contained a water reducer/retarder and a high-range water reducer. The approximate mixture proportions for 1 cu yd of concrete were as follows:

Portland cement	710 lb
Fine aggregate (natural sand)	1,320 lb
Coarse aggregate (crushed limestone, 3/4 in. max)	1,626 lb
Water	267 lb

Average compressive strengths of cylinders were 5,600, 6,800, and 7,800 psi at 3, 7, and 28 days, respectively.

The panels were loaded onto trucks and shipped about 2 miles to a river terminal. From the terminal, they were transported to the site by barges.

Anchors were installed in the lock wall. Panel anchors were No. 8, weldable-grade reinforcing steel, conforming to the requirements of American

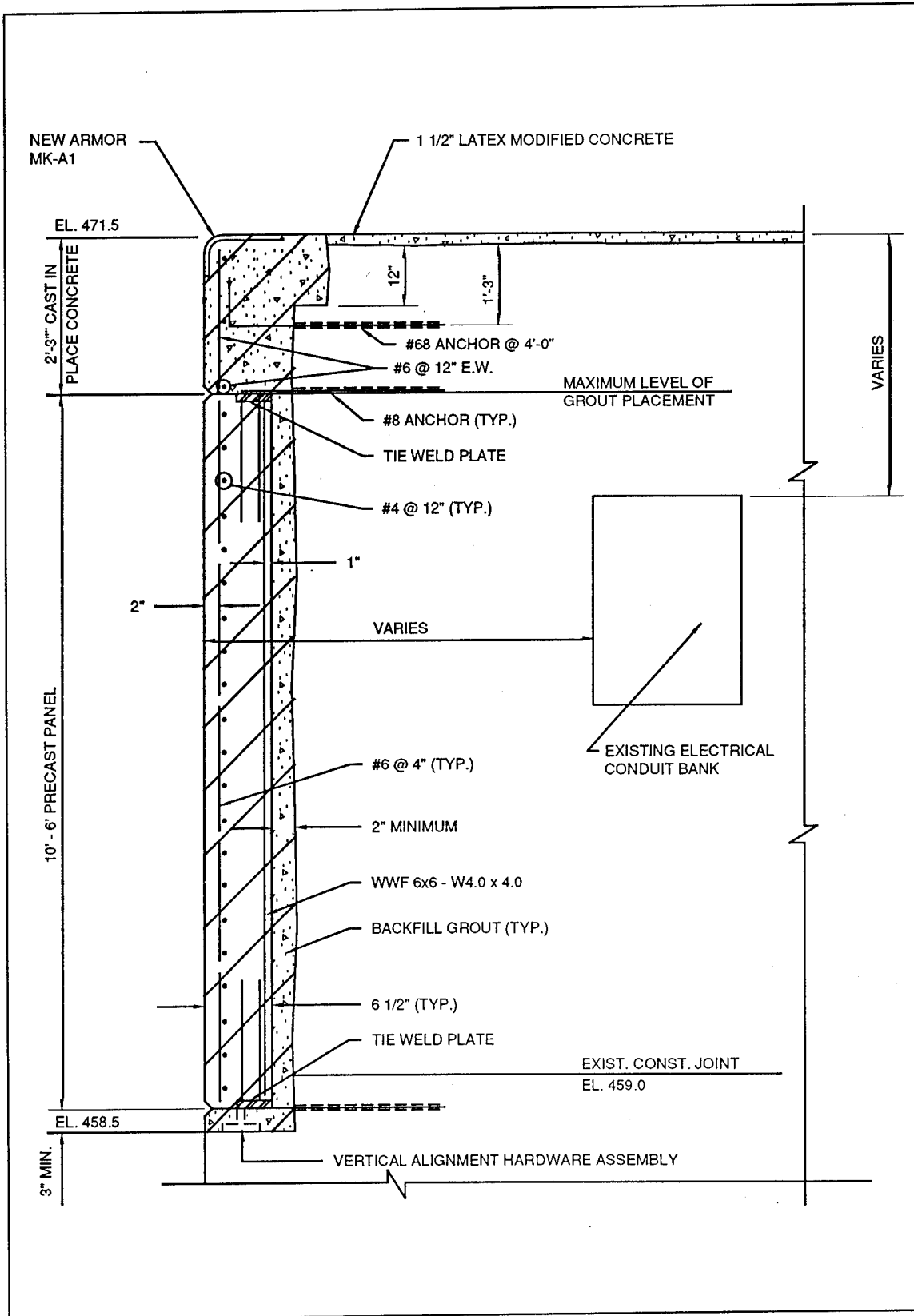

Figure 2. Typical lock wall repair section, Lock 22

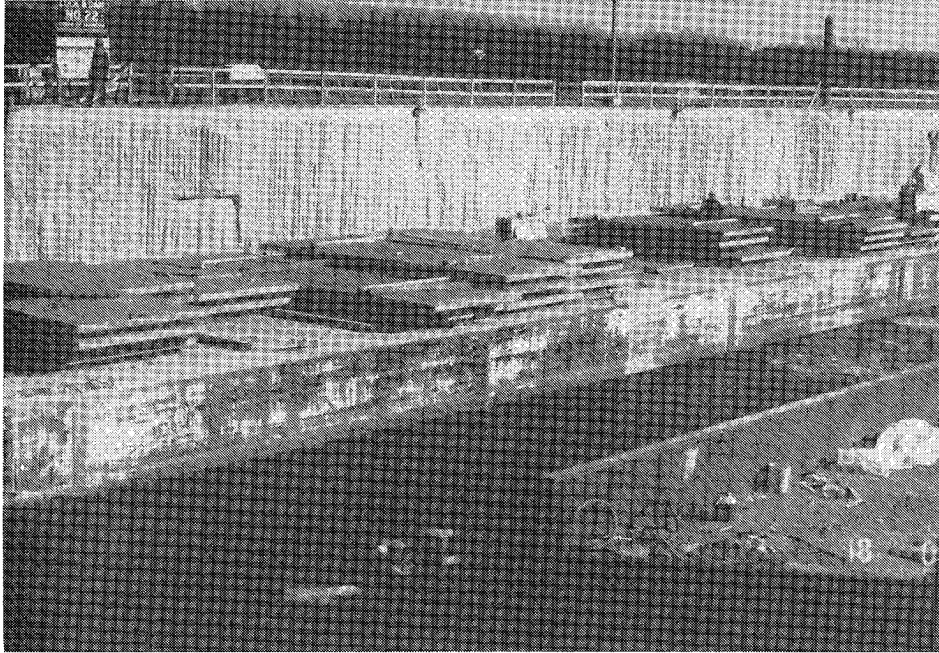

Figure 3. Condition of lock wall after removal of concrete. Precast panels on barges in lock chamber, Lock 22

Society for Testing and Materials (ASTM) A 706, Grade 60 (1988). The anchors were embedded in the original concrete to a depth of 2.5 ft and were located on 2-ft centers along the bottom of the panels. A polyamine epoxy mixed at the nozzle of a pneumatic hand-held gun was used to embed the anchors in the lock wall.

The panels were lifted into position with a crane (Figure 4) and held on the 8.5-in.-deep sawcut ledge while they were leveled with the vertical alignment hardware (Figure 5). The bottom panel anchors were welded to the weld plates embedded in the panels. Temporary mechanical anchors were installed at the top of the panels. The top panel anchors, No. 8 weldable bars on 2-ft centers, were then embedded in the wall and welded to the embedded weld plates (Figure 6). Each panel was aligned and welded in 2 to 3 hr. A compressible, asphalt-impregnated, open-cell foam was used to fill the vertical joints between the panels (Figure 7). A silicone joint filler was used to help hold the open-cell foam in place.

Forms were set along the bottom of the panel (Figure 8). Any overbreak areas below the removal line were saw cut and chipped to a depth of about 4 in. These areas were then formed. The formed overbreak areas and the space between the panel and lock wall were filled with nonshrink cementitious grout. The air-entrained grout was placed in two lifts to minimize deflection of the panel. Approximate mixture proportions for 1 cu yd of non-shrink grout were as follows:

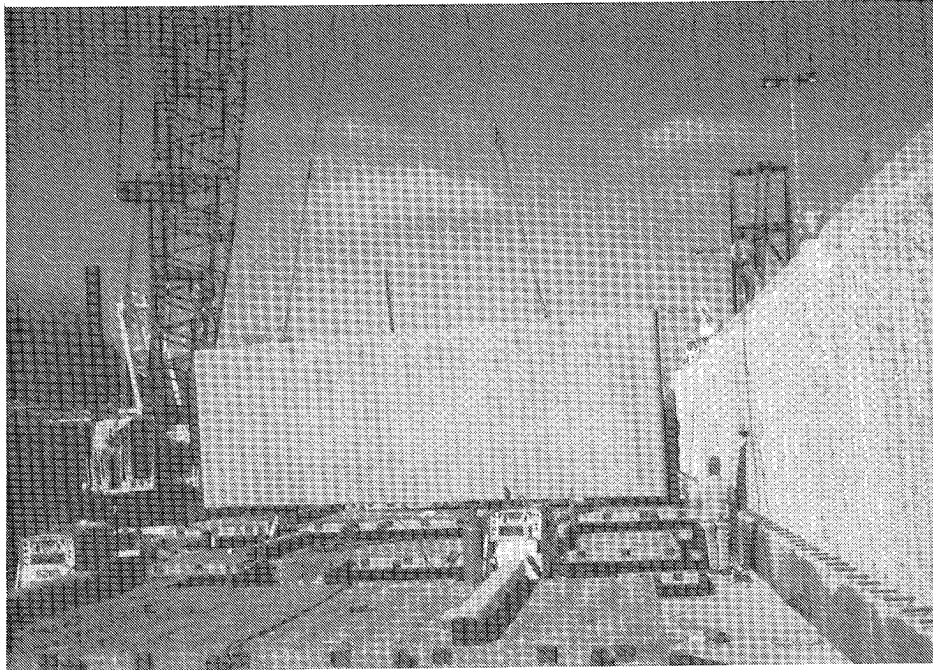

Figure 4. Panel installation, Lock 22

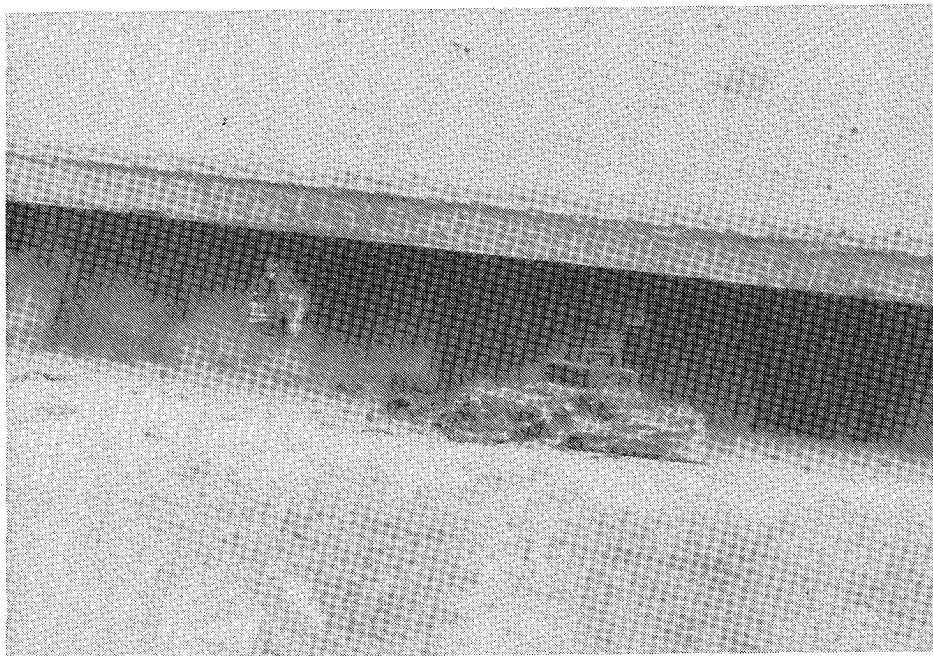

Figure 5. Vertical alignment hardware, Lock 22

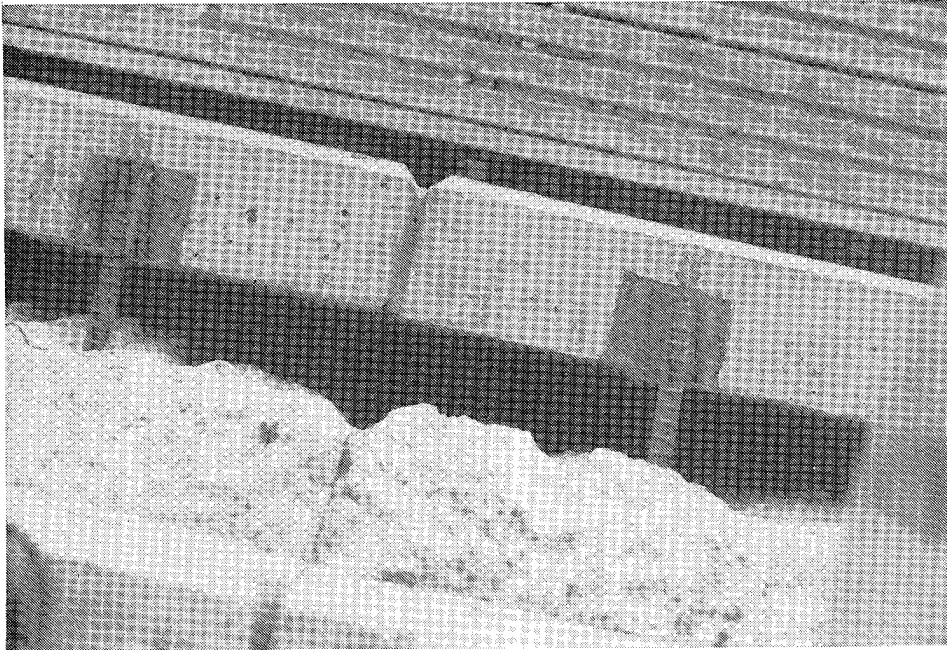

Figure 6. Panel anchors welded to weld plates along top of panel, Lock 22

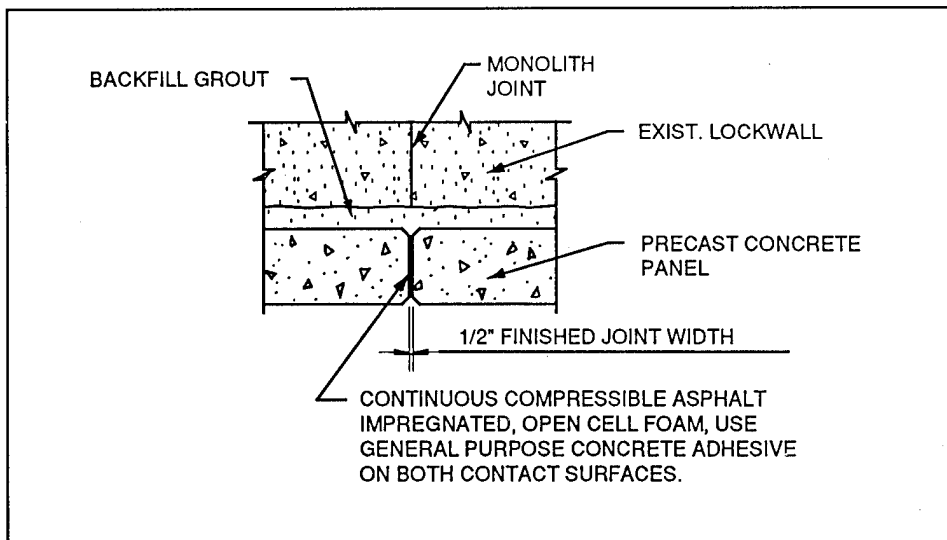

Figure 7. Vertical expansion joint, Lock 22

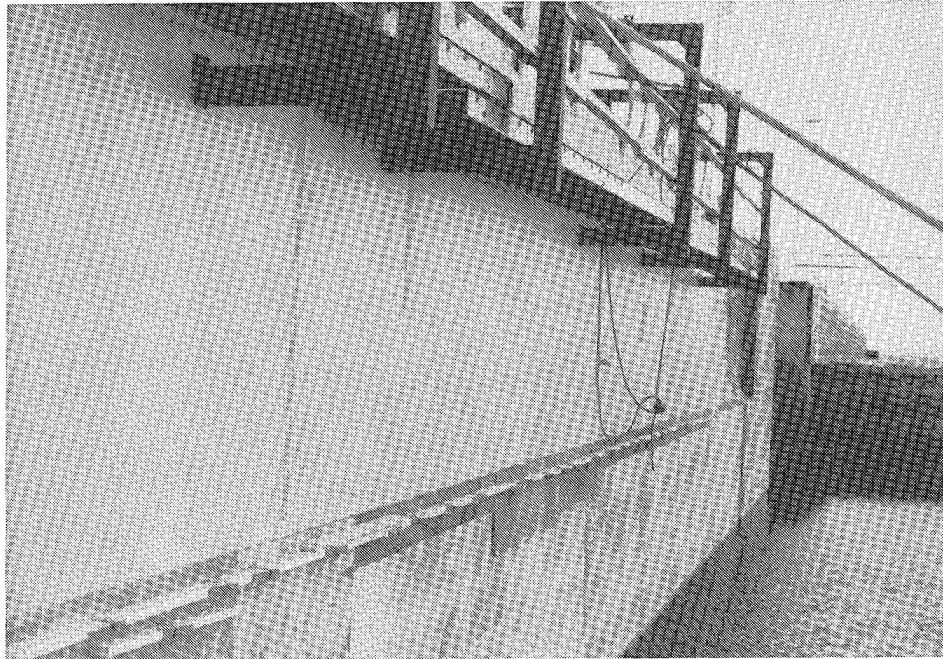

Figure 8. Precast panels and forms along bottom of panels in place and ready for placement of backfill grout, Lock 22

Cement	1,075 lb
Fly ash	225 lb
Sand (masons sand)	1,675 lb
Water	400 lb

Estimated quantities and bid prices (1987 dollars) for the precast panel repair were as follows:

Concrete removal	7,670 cu ft	\$ 345,150
Panel anchors	1,660 each	91,300
Precast panels	11,500 sq ft	506,000
Backfill grout	11,700 sq ft	105,300

		\$1,047,750

These costs do not include the cast-in-place concrete used in the upper 2.5 ft of the lock wall. Bid prices for this initial application of the precast concrete stay-in-place forming system for lock wall rehabilitation were somewhat higher than anticipated. However, the rehabilitation went very smoothly, despite severe winter weather conditions, and the precast panels were installed in about one-half the time that would have been required for cast-in-place concrete.

After the lock was reopened to navigation, the vertical monolith joints began to exhibit abrasion damage. The joints were subsequently repaired by tapering them 1 in. in 1 ft each way from the joint.

To eliminate protruding edges at joints, workers cut the panels with a diamond saw. The cuts were started at a 5-deg angle to the chamber face and 12 in. outside of the joints to produce a 1-in.-deep recess at the joints. This was the first time a cut at an angle this extreme had been done. The first two cuts were made with a 24-in. diamond blade; the final two, with a 30-in. blade. Uncut portions at panel corners were saw cut normally to the surface and then chipped and ground to complete the taper.

The blades were specially manufactured for this project. The 24-in. blade cost approximately \$1,000, and the 30-in. blade, \$1,500. A 53-hp Cushion saw motor and 17.5-gpm capacity Homelite pump were used. Cutting time per joint was estimated to be 2.5 hr, including the time required for moving equipment.

Spalled areas were removed with a chipping hammer and joints formed with styrofoam-type insulation boards. Latex was used to dry pack the spalled areas, and primer was placed on the concrete. Grout for the repair was mixed with 50-percent-by-volume, 3/8-in. maximum size aggregate plus equal volumes of water and latex. The grout was placed in 3/8-in.-thick layers. Aggregate was not used in the outer, or finishing, layer. Grout was finished with a steel trowel.

Electric heating blankets covered with polyethylene were mounted to 2- by 4-in. wooden frames to maintain temperature overnight. Curing time was estimated at 8 hr. Cured surfaces were roughened with a 6,000-psi water jet and then covered with a sealant.

Concrete removal was bid at \$138,600 (subcontract for saw cutting was \$81,100) and joint restoration at \$18,000 for the first 30 cu ft and \$6,000 for the next 15 ft of dry packing. There were 43 joints. Approximately 3 joints were sawed, and 2.6 cu ft of dry pack was placed per day.

Cores were taken through the precast panels to evaluate the abrasion damage. The cores exhibited good bond between the lock wall and the grout and good bond between the precast panel and the grout. The panels have been in place since February 1989 and are performing satisfactorily (Figure 9).

Troy Lock

Troy Lock and Dam is located on the Hudson River in Troy, NY. The original facilities were constructed in 1915 and opened for navigation in the spring of 1916, replacing a State of New York facility located 1,400 ft downstream. The lock chamber is 492.5 ft long, 44.4 ft wide, and 14 ft deep. The lock links the Port of Albany to the Village of Waterford, NY.

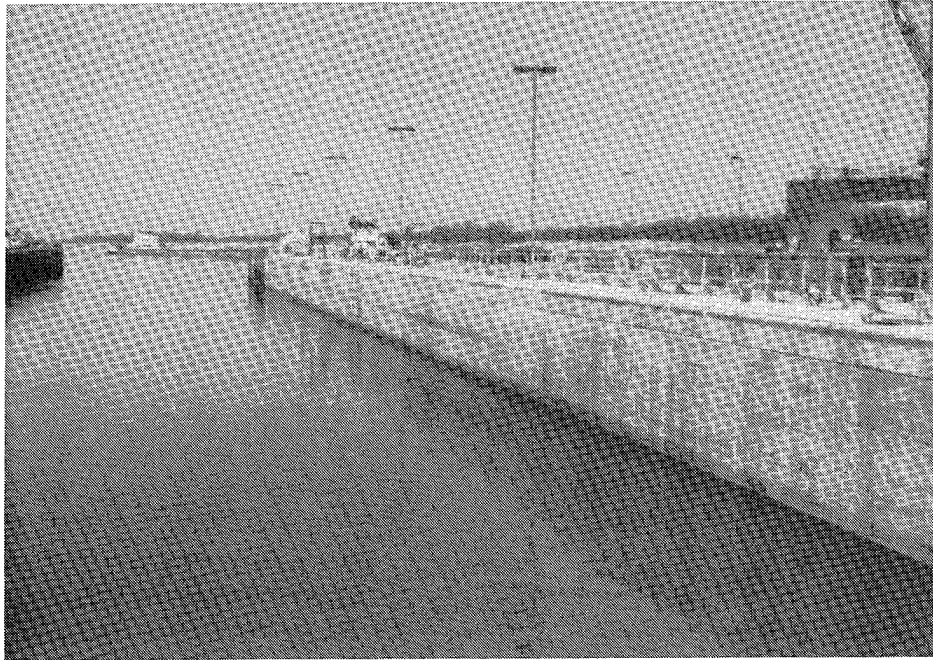

Figure 9. Completed lock wall rehabilitation, Lock 22

After approximately 60 years in service, the condition of the lock and dam was evaluated by the U.S. Army Engineer Waterways Experiment Station (WES). Rehabilitation of the lock and dam was recommended after a review of the results of an engineering condition survey (Pace 1978) and a structural evaluation (Pace, Campbell, and Wong 1981). Later work by Bergmann Associates, Rochester, NY, verified the need for remedial actions.

In 1987, Bergman Associates designed an interim repair program for the lock. This program included repair of the lock wall monoliths adjacent to the upstream and downstream miter gates, lock operating house, culverts, and valves. The miter gate monoliths were resurfaced with cast-in-place concrete. This work was completed in 1990.

Prior to the next phase of repair, the New York District and Bergmann Associates conducted a study to determine the relative merits of cast-in-place concrete and precast panels for resurfacing the remaining lock wall monoliths. This study included an evaluation of previous lock wall repairs with cast-in-place concrete and development of a preliminary design for precast panels with revised anchor details to simplify fabrication and erection. Constructibility, schedule, cost, and estimated service life of each repair method were compared in an effort to determine which method was most suitable to the site-specific conditions at Troy Lock. The study (Radley 1990) concluded that precast concrete was the superior repair method because it would provide a more attractive and durable repair for essentially the same cost as cast-in-place concrete. This conclusion was based upon the following:

- a. Total cost estimates for each method were approximately equal.

- b. The precast panels would make construction easier: the need for formwork and elaborate heated enclosures would be eliminated and the amount of quality control in the field would be reduced.
- c. Panels precast in a plant with a controlled environment would have higher quality concrete with higher compressive strength, abrasion resistance, and impermeability.
- d. Precast panels would be more durable because of their minimal cracking which reduces the potential for moisture penetration.
- e. The higher compressive strength and resultant increased abrasion resistance typical of precast panels would provide a more attractive and durable wall surface.

The second phase of the repairs, designed by Bergmann and constructed by Jackie Bombard, Inc., was completed in the fall of 1992. These repairs included (a) removal of deteriorated concrete from lock chamber monoliths and replacement with precast concrete stay-in-place panels and concrete infill, (b) installation of new ladders and line posts in the lock chamber, (c) resetting of existing snubbing posts, (d) removal of loose concrete from the backside of the river wall monoliths and installation of precast concrete jacketing with concrete infill, and (e) removal of deteriorated surface concrete on apron areas and replacement with cast-in-place concrete (Miles 1993).

Based on the experience gained at Lock 22, a number of revisions were incorporated into the design of the precast panel system used at Troy Lock. These revisions included new lifting, alignment, anchorage, and joint details. Also, the design was based on an allowable crack width of 0.006 in. compared to 0.01 in. at Lock 22.

Both a finite element model (STAAD--III) and conventional concrete design methods were used in designing the precast concrete panels. Because the panels would be subjected to two major load types, handling and infill concrete placement, these loads were evaluated and used in the design phase. Panel design details are described by Miles (1993) and summarized in the following.

Typical lock chamber panels were 7-1/2 in. thick and 11 ft 10 in. high. Panel lengths varied to align with existing monolith joints and ranged from approximately 6 to 21 ft. The panels were reinforced with No. 5 bars at 6 and 12 in. on center each way on the front and rear face, respectively. Two in. of concrete cover was provided on all faces. Lock chamber panels were precast with a 1- by 12-in. taper and a 1-in. chamfer along vertical joints to minimize spalling. Special panels were required at line pole and ladder locations in the lock chamber (Figure 10).

River wall panels were 5-1/2 in. thick with a typical length of 20 ft. Panels in the bottom row were 5 ft high for constructibility reasons in the tidal zone; those in the other two rows were 10 ft high. The panels were

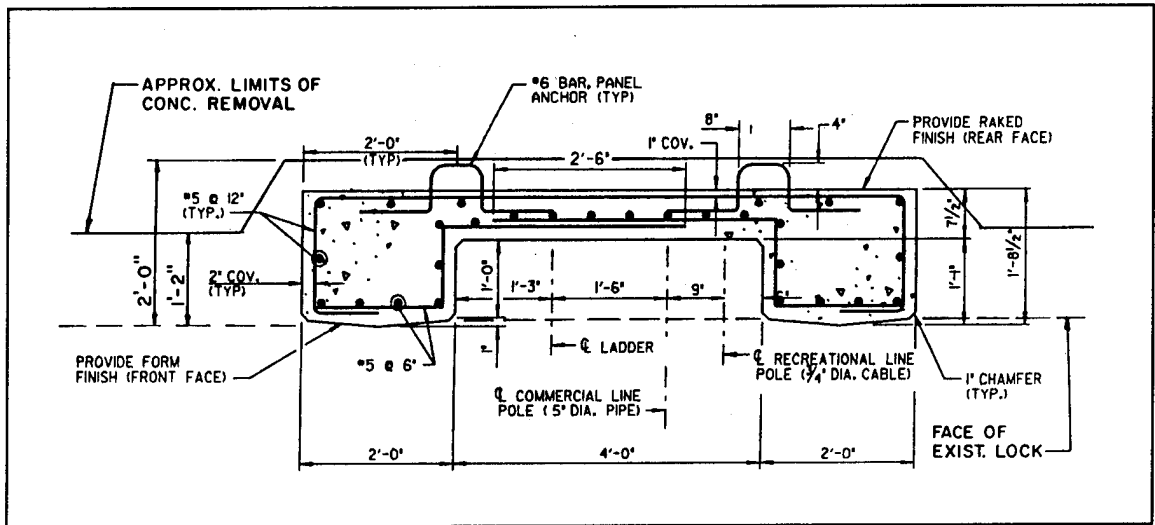

Figure 10. Typical ladder panel section, Troy Lock (from Miles 1993)

reinforced with a layer of No. 5 bars at 6 in. on center each way located 2 in. from the front face and a layer of welded wire fabric located 3/4 in. from the rear face. The panels were precast with a 1-in. chamfer on all exposed edges. Holes for shebolt anchors were preformed in the river wall panels.

Anchor details were similar for all panels, but the vertical spacing varied. Panel anchors consisted of a No. 6 hoop-shaped reinforcing bar which extended 4 in. from the rear face of the panels. Anchors were located at 4-ft horizontal spacing to match dowel spacing and at vertical spacings ranging from 3 ft 6 in. to 5 ft 4 in. Two 8-ton erection anchors were embedded in the top of each precast panel for lifting and handling.

The precast panels were fabricated in late 1991 and early 1992 at The Fort Miller Company plant, Schuylerville, NY, 20 miles north of the lock. The panels were precast in an insulated building maintained at 70 deg F.

An air-entrained concrete mixture with a water-cementitious ratio of 0.31 was used to provide the design strength of 7,000 psi at 28 days. Approximate mixture proportions for a 1-cu yd batch of concrete were as follows:

Material	Weight, lb
Portland cement, Type I/II (Brand A)	376
Portland cement, Type I/II (Brand B)	376
Fly ash, Class C	54
Fine aggregate	1,008
Coarse aggregate	1,815
Water	246

Low-range and high-range water-reducing admixtures were used to obtain an average slump of 7-1/2 in.

Concrete was placed with a concrete bucket handled by a gantry crane and then consolidated with external form vibrators; additional internal vibration was used in the corners of the panels as necessary. The concrete was finished with a wood float and then raked to create a rough surface to improve bonding to the infill concrete. The panels were wet cured overnight in the molds; then they were removed from the molds, stacked, and covered with wet burlap, which was covered with polyethylene to prevent loss of moisture. The final curing required from 5 to 7 days until design strength had been reached, and then the panels were stored in the casting yard (Figure 11) until shipment to the lock.

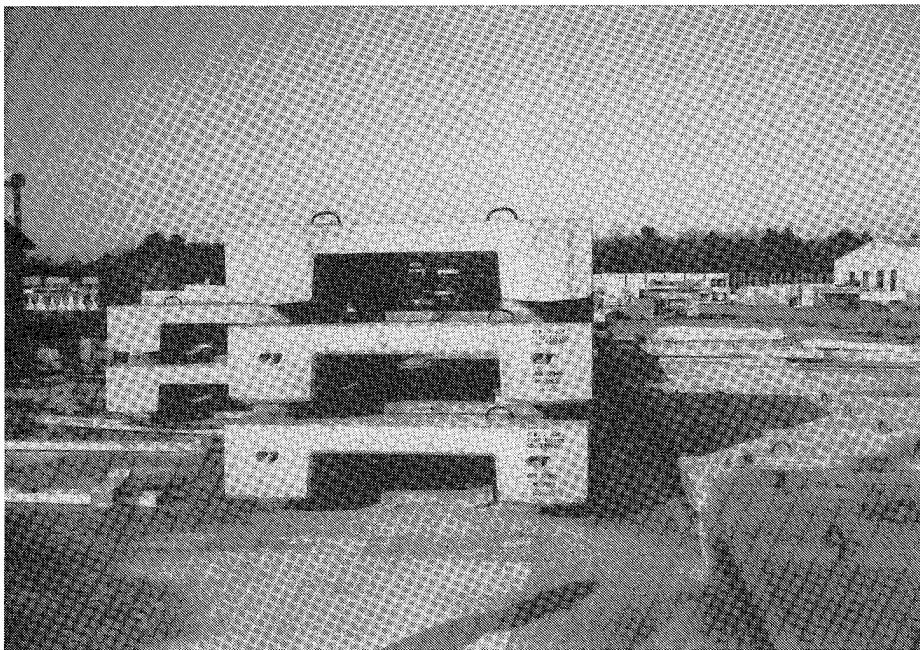

Figure 11. Panel storage in precast plant yard, Troy Lock (from Miles 1993)

While the panels were being precast, the lock chamber walls were being prepared for installation of the panels. Surface concrete was removed to a minimum depth of 12 in. by blasting and grinding. The perimeter of areas to be blasted was saw cut. Also, a 10-in.-deep horizontal sawcut was made at the lower limit of the removal areas to provide a finished ledge for precast panel placement. Following concrete removal, exposed surfaces were cleaned by sandblasting and high-pressure air.

No. 6 deformed reinforcing bars were used as anchor dowels. Holes for the hooked dowels were drilled into the existing wall in a pattern that would align with the panel hoop anchors. The dowels were embedded in a two-part epoxy bonding system.

Lock chamber panels (Figure 12) were installed during the winter of 1991-1992 when the lock was closed to shipping. The precast panels were lifted from delivery trucks with a crane and lowered onto steel shims placed on the saw-cut ledge. The panels were positioned with temporary holding and adjustment brackets, shebolt form anchors at the top and bottom of the panels at 4-ft spacings, and steel strongbacks spanning between the shebolts. Once the panels were positioned, No. 6 reinforcing bars were inserted vertically to intersect the panel anchor hoop and the dowel bar hook (Figure 13). All panels were carefully checked for cracking prior to being lifted from the delivery trucks and after being set into position; no cracks were observed.

Wooden forms were set along the 2-in. horizontal joint below each row of panels prior to placement of the infill concrete. In addition, a foam backer rod was placed in the 1/2-in. vertical joint between panels. An air-entrained concrete mixture proportioned with 3/4-in. maximum size aggregate for a compressive strength of 3,000 psi at 28 days was used for the infill concrete. A concrete bucket fitted with a flexible elephant trunk was used to place the concrete to midheight of the panels. After the first lift of concrete was consolidated and allowed to set, infill concrete was placed to the top of the panels (Figure 14).

Most of the lock chamber panels were set and infill concrete placed from January to mid-March 1992 when ambient temperatures ranged from 0 to 40 deg F. A temporary, heated enclosure (Figure 15) was used to maintain the air temperature of 40 to 55 deg F specified for curing of the infill concrete. Following curing of the infill concrete, the foam backer rod was removed and the infill concrete saw cut to full depth. Vertical joints were then left open to aid in drainage of any seepage through the walls. The top of the precast panels was sealed with a 2-ft-thick, reinforced-concrete cap cast in place.

One hundred-twelve panels of varying dimensions were installed during a 7-week period. The initial daily rate of installation, including setting, aligning, and anchoring was 1 or 2 panels per day. However, as the contractor became more familiar with the system, the installation rate improved to as many as 10 panels per day. An average rate of 3.8 panels per day was achieved for the 26 days in which panels were actually installed. A significant portion of the installation time was spent erecting the strongback supports and setting forms for the infill concrete, which was placed during the same 7-week period.

Upon completion of the lock chamber resurfacing, an inspection of the panels revealed that 11 of 112 panels exhibited some fine cracks. As required by contract specifications, cracks with widths ≥ 0.006 in. (four locations) were repaired in place with an injection resin. Cracks with widths < 0.006 in. (seven locations) were sealed at the surface with a paste epoxy bonding agent.

In addition to resurfacing the lock chamber walls, precast concrete panels were also used to overlay the back side of the river wall at Troy Lock. Original plans for repair of this area required extensive removal of deteriorated

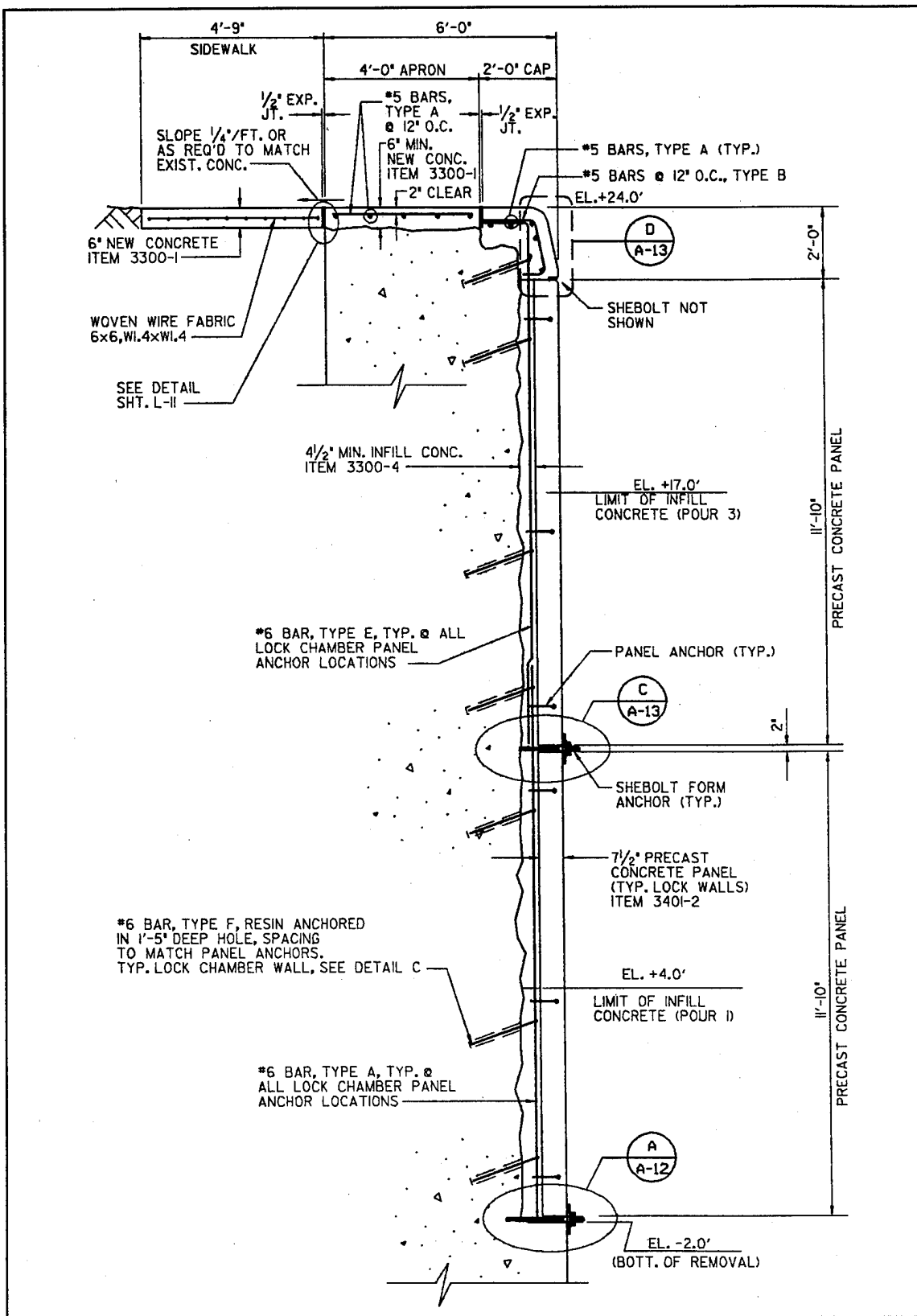

Figure 12. Typical land wall repair section, Troy Lock (from Miles 1993)

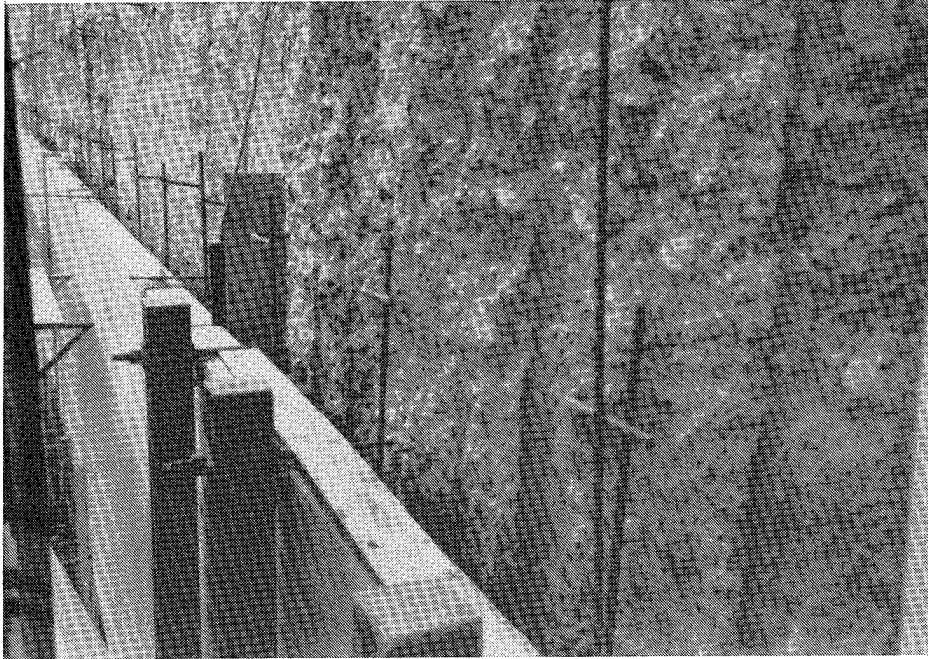

Figure 13. Top of precast panel prior to placing infill concrete, Troy Lock (from Miles 1993)

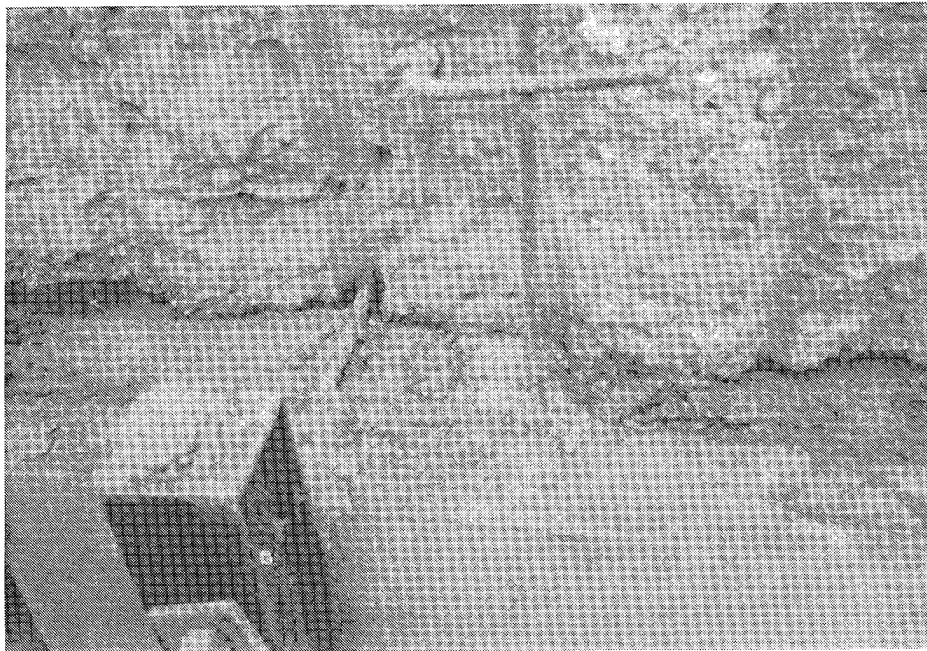

Figure 14. Top of precast panel following placement of infill concrete, Troy Lock (from Miles 1993)

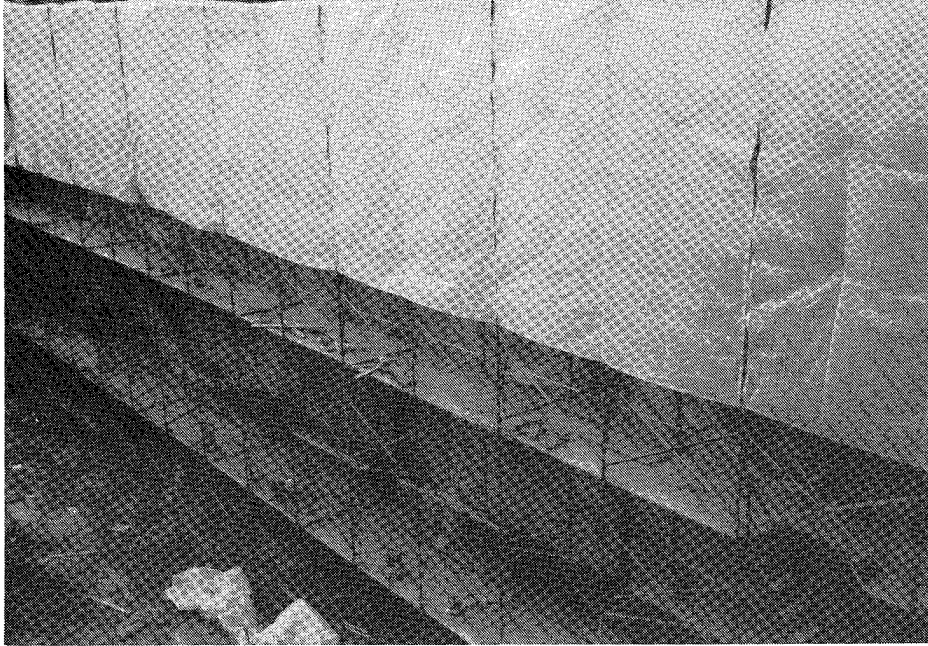

Figure 15. Heated enclosure for curing of infill concrete, Troy Lock (from Miles 1993)

concrete and replacement with shotcrete. This repair, which would have had to be accomplished in the dry, would have required construction of an expensive cofferdam to dewater the area. Consequently, the New York District decided that concrete removal could be minimized and the need for a cofferdam eliminated if this area was repaired with precast concrete panels (Figure 16). Concrete removal on the back side of the river wall was limited to that required to install the cast-in-place concrete cap and localized removal of loose concrete. Jackhammers and hand tools were used for this work.

The river wall overlay was installed in the spring and summer of 1992 while the lock was in operation. The panels were rigged to approximate the slope of the river wall (Figure 17) prior to swinging them into place with a crane positioned adjacent to the land wall of the lock chamber. Even though the contractor scheduled installation for periods of low tide, the bottom row of panels was set in 1 to 3 ft of water. The panels were set into final position with adjusting bolts and shebolt form anchors through each panel. An alignment laser was used for final vertical and horizontal alignment of all panels.

Except for the bottom row of panels, anchoring and infill concrete placement procedures (Figure 18) were similar to those previously described for the lock chamber. In this case, an antiwashout admixture allowed the infill concrete to be effectively placed underwater without a tremie seal having to be maintained. Curing consisted of keeping the top exposed surface of infill concrete wet for a minimum of 7 days. Heating was not required because ambient temperatures ranged from 50 to 80 deg F. After the infill concrete was properly cured, a polyurethane elastomeric joint sealant was added to the

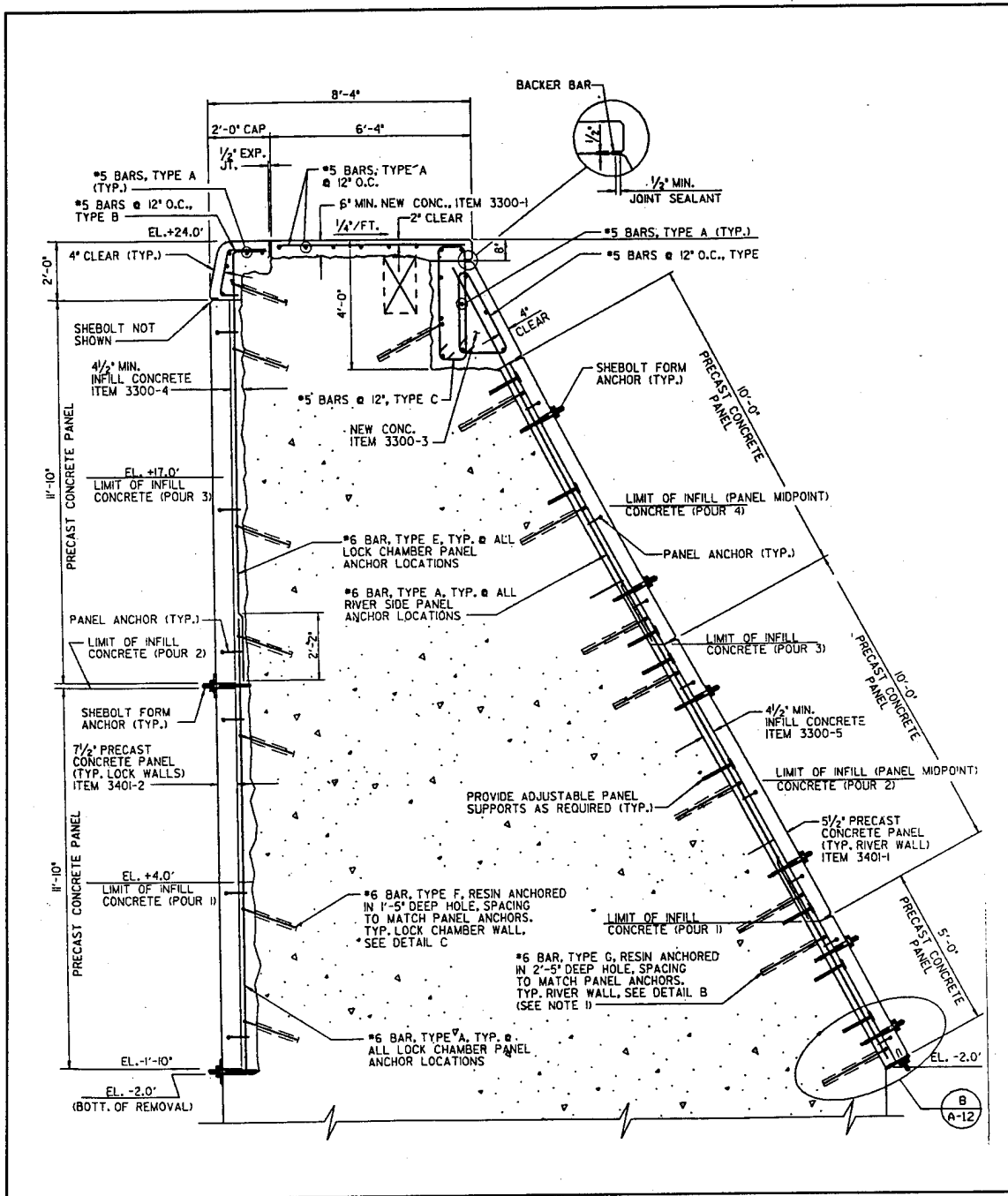

Figure 16. Typical river wall repair section, Troy Lock (from Miles 1993)

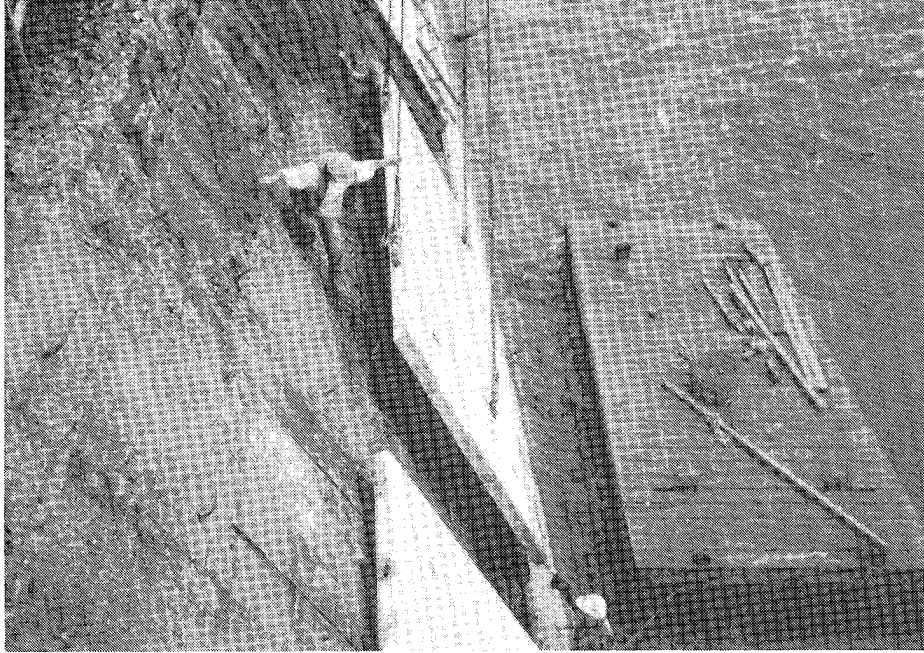

Figure 17. River wall panel installation, Troy Lock (from Miles 1993)

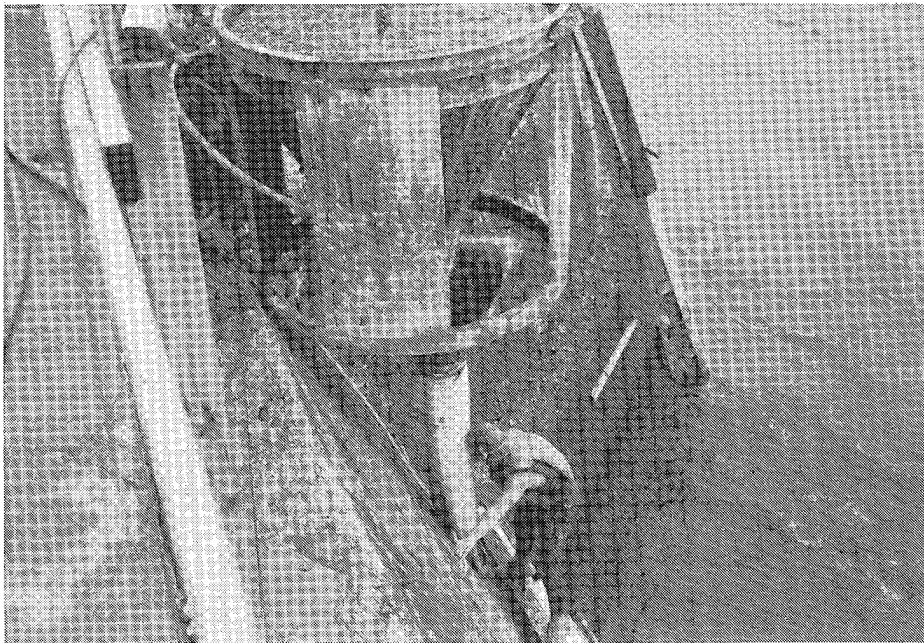

Figure 18. Infill concrete placement and consolidation on river wall, Troy Lock (from Miles 1993)

vertical joints above the tidal zone. Joints within the tidal zone were left open because a flexible sealant which would cure within the available time between tides could not be found.

Sixty-five panels were installed on the river wall in a 9-week period. The initial daily installation rate was only one or two panels per day; however, this rate improved to as many as eight panels per day with an average rate of three panels per day during the 23 days in which panels were actually installed. An inspection upon completion of the overlay failed to locate any cracks in the panels.

The application of precast concrete in repair of the river wall resulted in an estimated savings of approximately \$500,000 compared to the original repair method. Also, the durability of the aesthetically pleasing precast concrete should be far superior to shotcrete, which has a generally poor performance record in repair of hydraulic structures constructed with nonair-entrained concrete.

A final inspection of the precast panels revealed them to be smooth, uniform in color, and neatly aligned. Their smooth surface provides for less accumulation of sediments and algae, resulting in cleaner appearance (Figure 19). In contrast, the monoliths resurfaced with cast-in-place concrete, with their extensive cracking, seepage lines, rougher texture, and less uniform coloring have a more deteriorated appearance (Figure 20).

The contractor's bid price for resurfacing the lock chamber with precast concrete was only \$33 per sq ft at Troy Lock compared to \$91 per sq ft at Lock 22. The mean bid price for precast concrete at Troy Lock was approximately \$5 per sq ft lower than the mean bid price for cast-in-place concrete during the same period. Both bid prices included removal of existing concrete, anchor systems, and replacement concrete. Although the contractor at Troy was inexperienced in both lock rehabilitation and the use of precast concrete, the project progressed quite smoothly, and the efficiencies of using precast concrete became very obvious as the project was completed. It is anticipated that as the number of qualified precast suppliers continues to increase and as contractors become more familiar with the advantages of precast concrete, the costs of the precast concrete stay-in-place forming system will be reduced.

These applications of both cast-in-place concrete and precast concrete in the same rehabilitation provided a unique opportunity for a direct comparison of the relative merits of the two systems. Compared with cast-in-place concrete, precast concrete exhibited a number of advantages including minimal cracking, durability, rapid construction, improved impact and abrasion resistance, improved appearance, and anticipated reductions in future maintenance costs. Also, precasting minimized the impact of adverse winter weather.

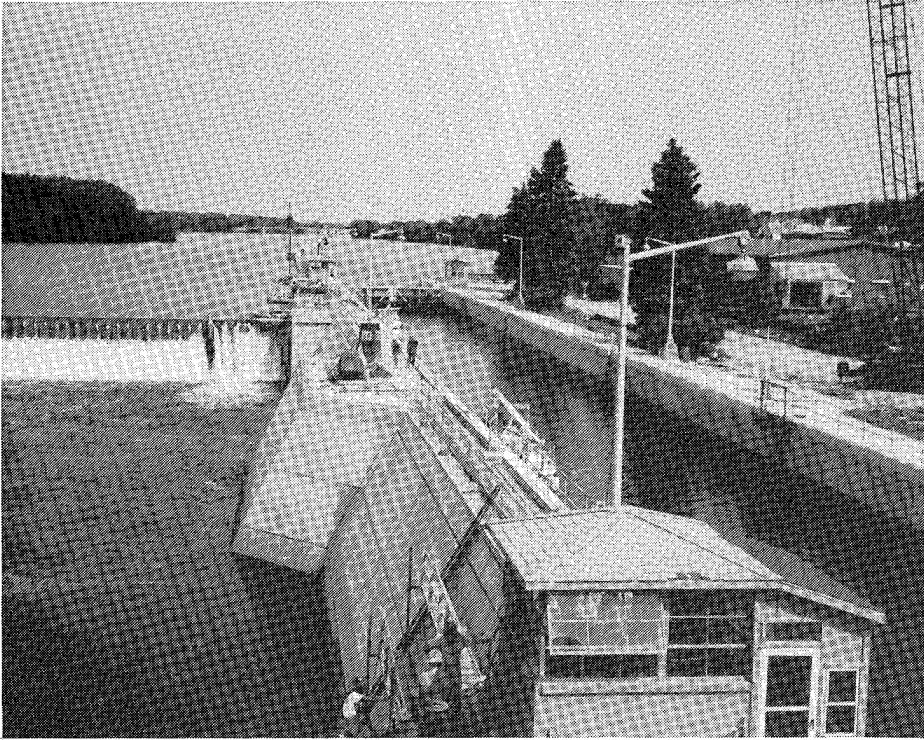

Figure 19. Precast concrete panel installation completed, Troy Lock (from Miles 1993)

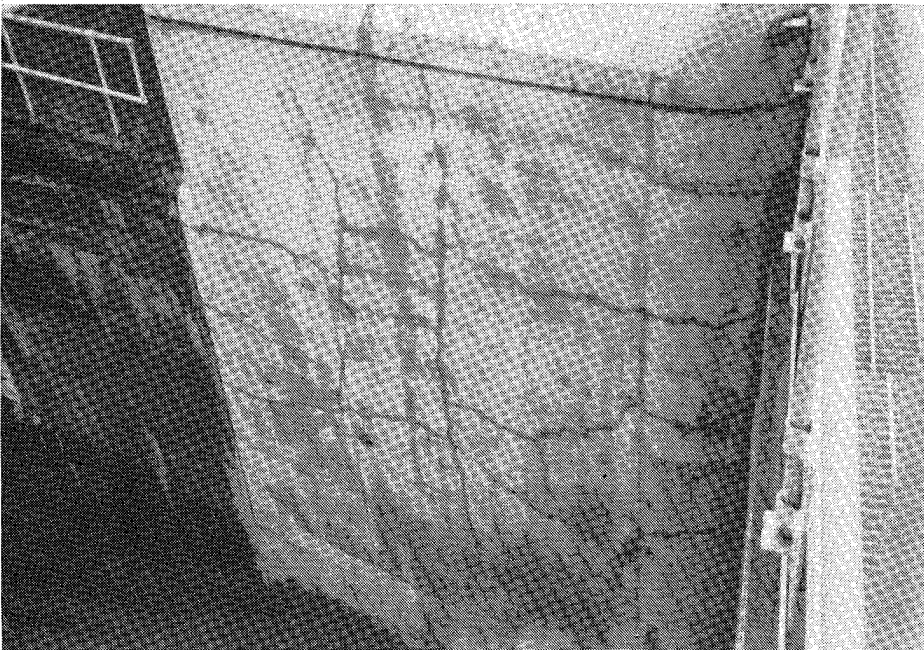

Figure 20. Typical cast-in-place concrete resurfacing of miter gate monoliths, Troy Lock (from Miles 1993)

Lockport Lock

Lockport Lock is located on the Illinois Waterway adjacent to the city of Lockport, IL. The lock is 110 ft wide and 600 ft long with a maximum lift of about 39 ft. The river wall of the lock is a gravity section keyed into bed-rock. The total height of the wall is 66 ft. The riverside of the river wall has a 38-ft-high exposure.

WES performed a condition survey in 1978 (Stowe et al. 1980). A summary of the condition survey follows: freezing and thawing of non-air-entrained concrete was the major cause of damage; alkali-silica reaction was the minor cause. The average depth of damaged concrete was 0.2 and 1.3 ft in the lock chamber wall and just downstream of the lower gate bay, respectively. Severe damage existed at monolith joints, especially on the backside of the river wall (Figure 21). Beyond the damaged concrete zones, the concrete was sound (compressive strength 6,000 plus psi).

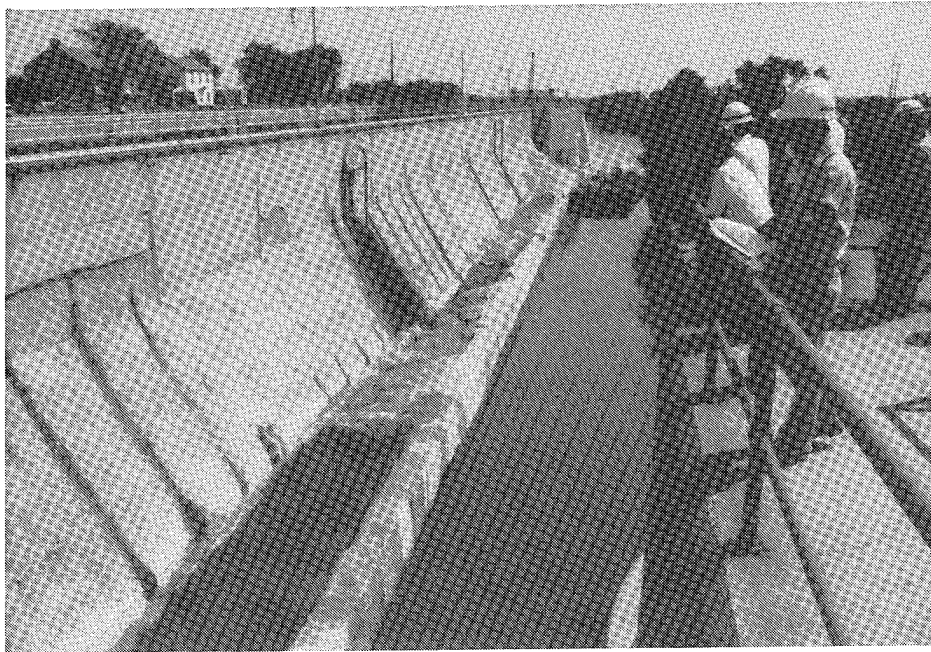

Figure 21. Condition of river wall prior to repair, Lockport Lock

Major rehabilitation performed in 1984 during Stage I is documented by McDonald (1987b). Stage II rehabilitation consisted mostly of filling/emptying valves, constructing lower guide walls, sealing vertical monolith joints, and resurfacing the lower horizontal ledge of the river wall. Stage III rehabilitation included construction of bulkhead slots, installation of new, upper lift-gate machinery, and resurfacing of the riverside of the river wall. Conventional cast-in-place concrete and precast concrete panels were used to repair the riverside of the river wall (Figure 22).

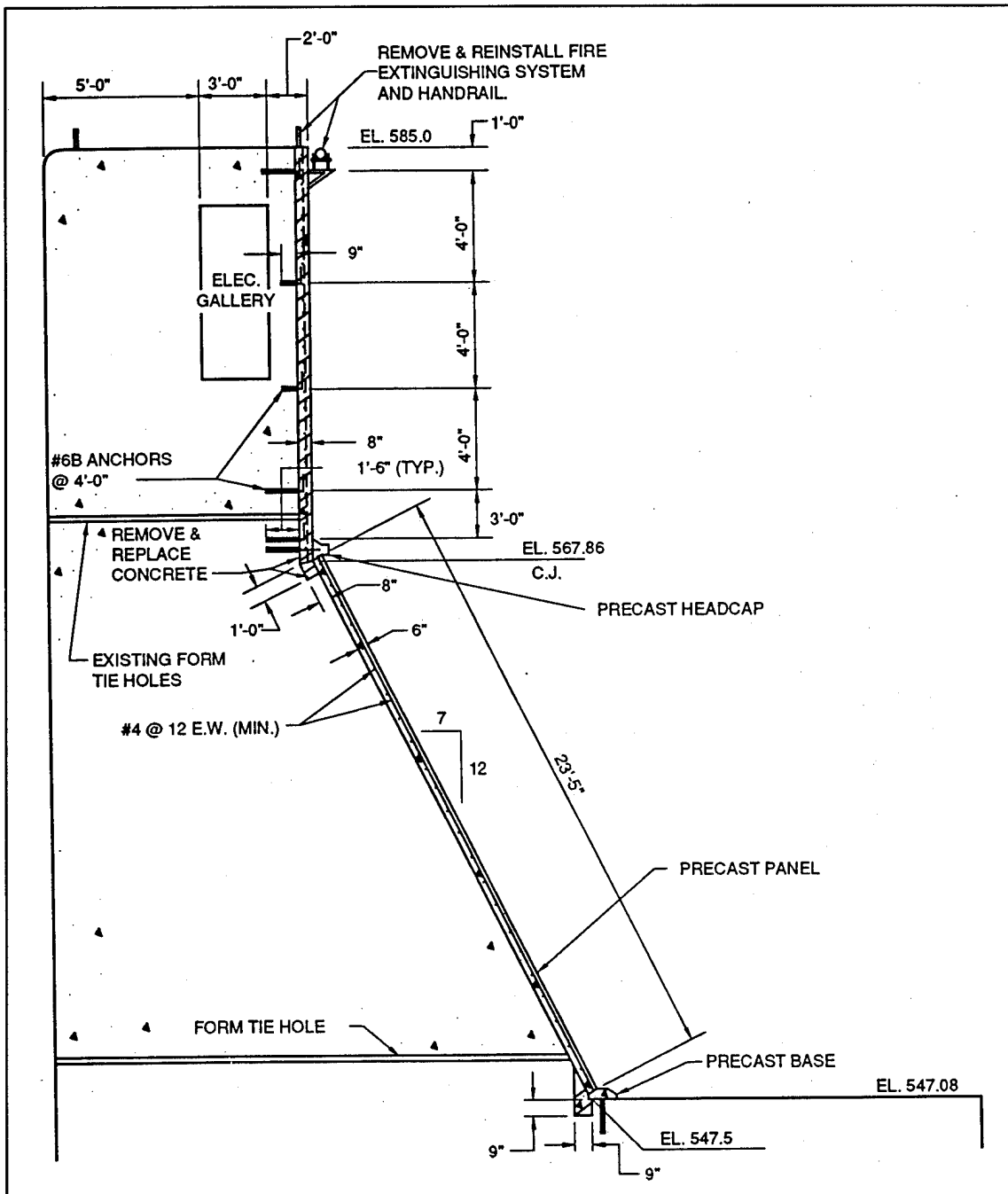

Figure 22. Typical river wall section, Lockport Lock

The river wall of the lock is a gravity section keyed into bedrock. The total height of the wall is 66 ft. The riverside of the river wall has a 38-ft-high exposure. The top 17 ft of the wall has a vertical face, while the lower 21-ft section is battered 12V on 7H. On portions of the vertical face, the deteriorated concrete was removed and replaced with cast-in-place concrete.

Precast prestressed panels were used to overlay the battered portion of wall. Before the panels were placed, the concrete surface was cleaned of all

loose concrete with a high-pressure water jet. Then the precast concrete base was installed. The reinforced concrete base was set along the horizontal surface at the base of the wall (Figure 23). The sections were 7.5 ft long by 7 in. high by 1.3 ft wide at the bottom. Two steel bearing plates were embedded in each section during precasting.

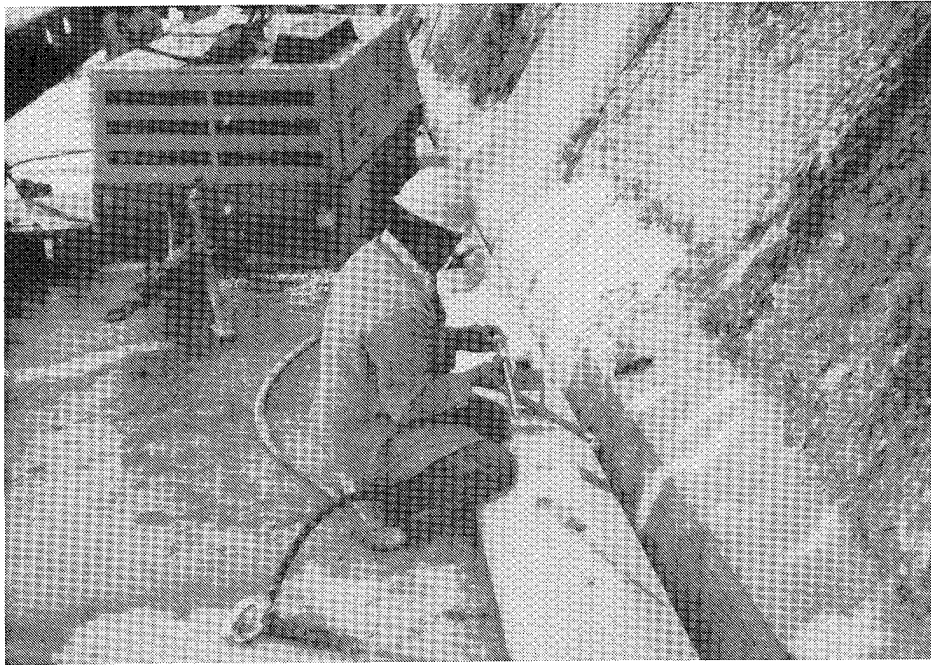

Figure 23. Precast base installation, Lockport Lock

The base sections had two preformed bolt holes and recesses to accommodate 3/4-in.-diam mechanical anchors. As soon as a base section was in place, a drill bit was inserted through the bolt hole, and a hole was drilled in the horizontal deck surface. The mechanical anchors were installed, and the recesses in the top of the base were filled with nonshrink, cementitious grout.

The 6-in.-thick precast wall panels were 23.16 ft high and approximately 7.5 ft wide. The panels were reinforced with No. 4's at 24-in. centers, horizontally, welded wire fabric (WWF 6 by 6, 10/10), and vertical prestressing strands (1/2-in. diam by 250 ksi). Other embedded items included weld plates at the bottom of the panels and steel angles with embedded bolts at the top of the panels. Panel widths were adjusted so that lock monolith joints would be at the same locations as the panel joints.

The 6.5-ton panels were lifted into place with a crane (Figure 24). Steel shims were placed between the panel and the base at the weld plates. At the top of the panel, steel angles aligned with the steel angles embedded in the panel were secured to the wall with 3/4-in. bolts. Slots in the angles allowed for alignment adjustments of the panels. After the bolted connections were tightened at the top of the panel, the steel shims at the bottom of the panel were welded to welding plates on the base and the panel.

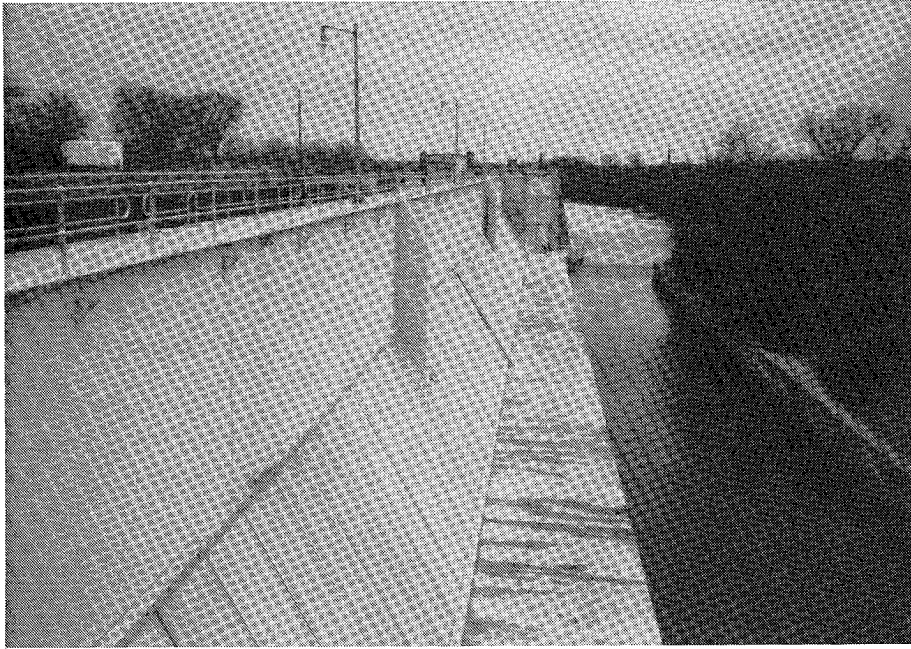

Figure 24. Placing precast panels, Lockport Lock

The precast headcap sections were lifted into place and set on the shims between the top of the panel and the cap (Figure 25). After alignment, the caps were secured to the wall with mechanical anchors.

Backer rods and joint sealant were installed in the vertical joints between the panels. The back of the joints was left open to allow for drainage of any seepage through the lock wall. Backer rods and joint sealant were installed in the joint between the panel and the headcap. Joint sealant was placed along the top of the headcap.

The contractor's bid price for 11,550 sq ft of the precast panel was \$242,550. The panels, which have been in place since the fall of 1989, are performing satisfactorily (Figure 26).

Melvin Price Locks

The original plan for construction of the downstream guidewall at the Main Lock, Melvin Price Locks and Dam, was to build a steel sheet-pile cofferdam around the area, dewater the cofferdam and build a conventional reinforced concrete guidewall. As the design progressed, it was determined that installation of a cofferdam and dewatering would cost an estimated \$9.2 million. Therefore, an engineering study was conducted to determine the feasibility of constructing the guidewall without dewatering the site. This study concluded that the 855-ft-long guidewall could be constructed with precast concrete beams and pile-founded sheet-pile cells filled with tremie concrete without

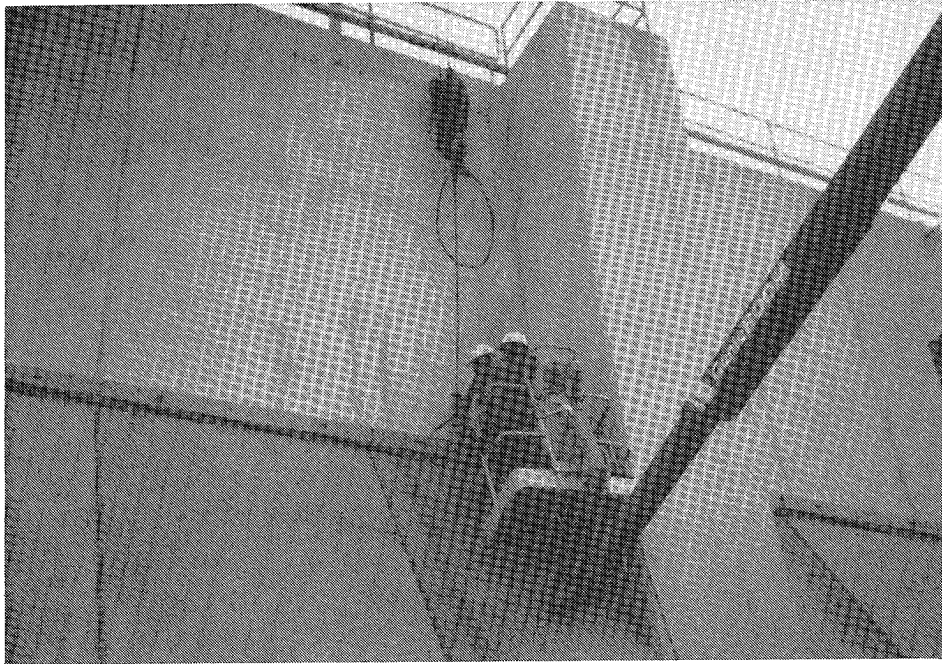

Figure 25. Precast headcap installation at top of panels, Lockport Lock



Figure 26. Completed river wall repair, Lockport Lock

dewatering the site. This design change resulted in an estimated construction savings of \$7.9 million (Jaeger 1986).

Sixteen sheet-pile cells, each 35 ft in diam, were placed on 57-ft centers and driven to bedrock. Inside each cell, fourteen 70-ft-long, H-beam piles were driven to bedrock to provide a foundation. When the foundation was complete, the cells were filled with tremie concrete to the required bottom elevation of the guidewall. Then six precast concrete beams, each 55 ft long by 7 by 8 ft, were stacked to span the sheet-pile cells (Figure 27) and form the face of the guidewall against which barges would rest. Steel armor plate was embedded in the beams during precasting to provide protection from barge impact. Each beam weighed 225 tons and was designed to resist a 670,000-lb impact force (*Highway & Heavy Construction* 1988).

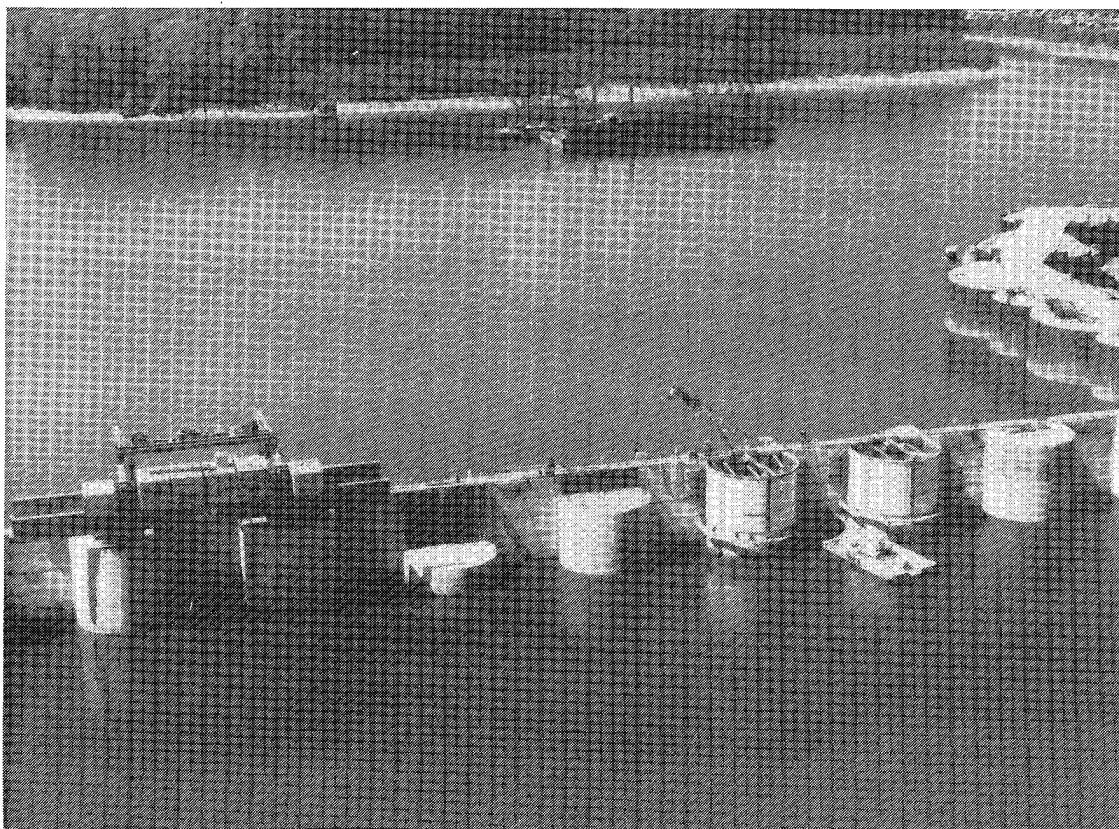

Figure 27. Precast concrete beams installed on downstream guidewall, Melvin Price Main Lock (from *Engineer Update* 1990)

Because of the size of the precast beams, the contractor was concerned over how to handle and align them during installation. The solution was to use a heavy-lift cantilever-type crane. A 125-ft-long girder supported by three of the guide wall's permanent cells served as a support rail for the crane. The girder was moved from cell to cell as segments of the guide wall were completed. This system had no difficulty lifting the 225-ton beams directly from the barges. Rigging, lifting, and placing each beam required approximately an hour (*Highway & Heavy Construction* 1988). After the precast

beams were installed, concrete was placed in the sheet-pile cells to the top of the guidewall. This project was selected for a 1989 Award of Merit in the Chief of Engineers' 20th Design and Environmental Awards Program (*Engineer Update* 1990).

A similar procedure was also used to construct the upstream and downstream guidewalls at the Auxiliary Lock. A total of 202 precast beams were used to construct the guidewalls. The dimensions of these armored beams were the same as those for the main lock. The beams were precast by Egyppec, a joint venture of Egyptian Concrete Co. of Salem, IL, and Prestressed Engineering Corp. of Algonquin, IL. They were cast at a temporary plant along the Ohio River in Mt. Vernon, IN, to take advantage of existing cranes with sufficient capacity to handle the 225-ton units. The beams were match cast at a rate of three beams per week. Each beam required 106 cu yd of concrete and was reinforced with a 10-ton steel cage.

The beams were transported to the project by barge with six beams per barge. A ringer crane mounted on a barge (Figure 28) was used to lift and place the beams. The beams were stacked four high on the upstream guidewall and six high on the downstream guidewall (Blaha 1993).

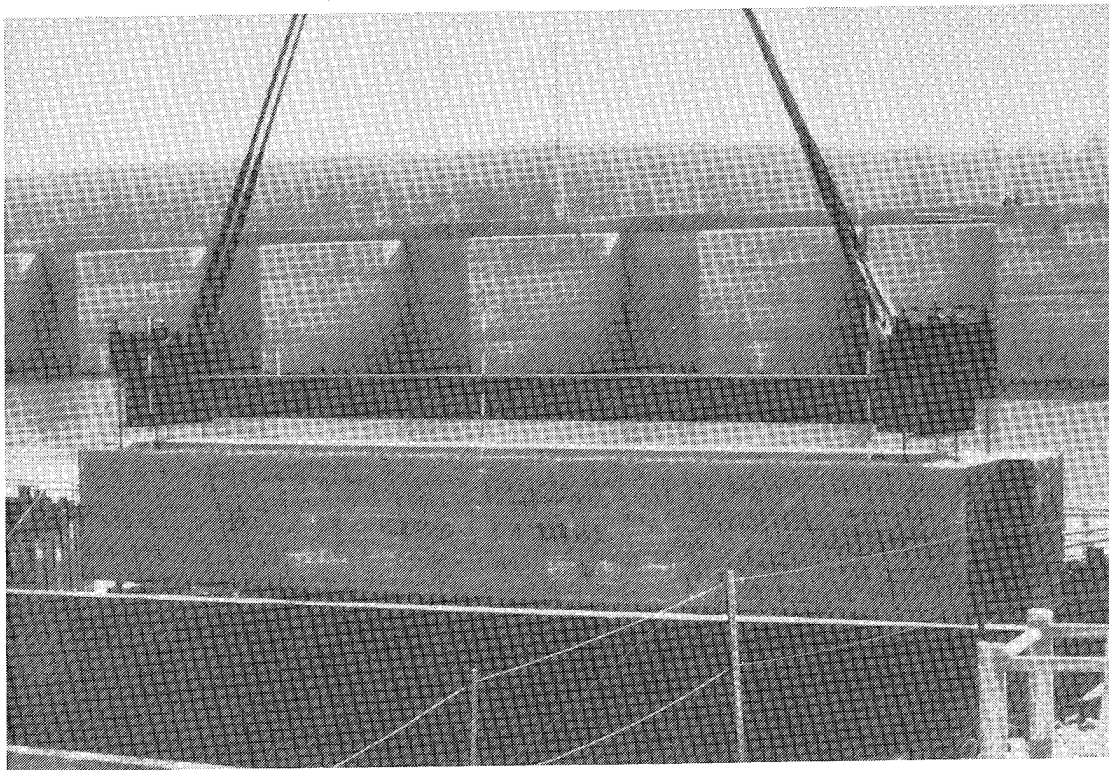

Figure 28. Offloading precast beams for Auxiliary Lock guidewall, Melvin Price Locks

Bonneville Lock

Construction of a large new lock was recently completed at Bonneville Dam on the Columbia River. The upstream guidewall is 830 ft long with approximately one-half of the wall floating. The floating portion is attached to the fixed section next to the lock by a mechanism similar to a giant door hinge that permits it to rise and fall. The floating portion of the wall blocks access to the old lock; however, it can be removed to put the old lock back into service if necessary.

Feasibility studies for the floating wall considered all-steel pontoons as well as concrete boxes with steel armor on the channel side. Designers selected post-tensioned concrete box girders precast with 9/16-in.-thick face plates backed by flanged stiffeners. The precast concrete sections, 26 ft deep and segments to ease transportation. However, value engineering by the contractor resulted in construction of a single section weighing 8,500 tons in the dry. The concrete wall was precast in a dry dock upstream of the lock and floated to the project site (Figure 29). The entire job took about 5 months, including 3 weeks for installation (Soast 1993).

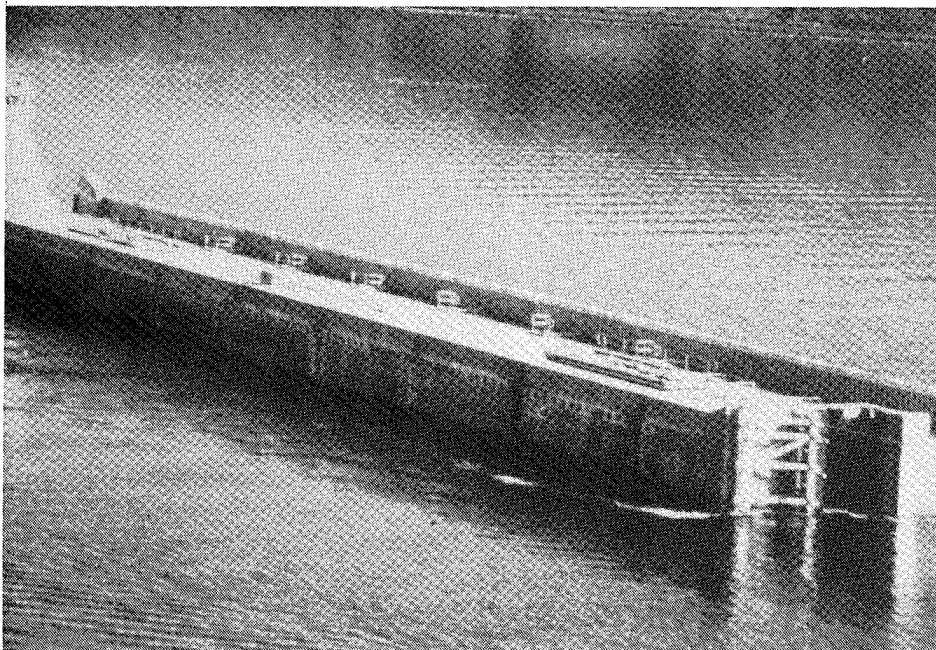

Figure 29. Precast concrete floating guidewall, Bonneville Lock (from Soast 1993)

Dams

The use of precast concrete in repair, rehabilitation, and replacement of dams has increased significantly in recent years. These innovative applications include stay-in-place forming systems for resurfacing dams, gallery

construction in roller-compacted concrete (RCC) buttresses, and underwater repair erosion-damaged spillways; precast panels to raise the crests and provide wave walls for embankment dams; cellular concrete mats for erosion protection of embankment dams during overtopping; modular sections for partial and complete construction of dams, piers, abutments, and baffle blocks; and preformed caps for parapet walls.

Barker Dam

Barker Dam, a cyclopean concrete gravity structure completed in 1910, is located at elevation 8,200 ft 17 miles west of Boulder, CO. The dam, which is approximately 175 ft high with a crest length of 720 ft, forms the Barker Reservoir. The 12,000-acre-ft reservoir supplies the Boulder hydroplant about 12 miles downstream from the dam.

The dam underwent major rehabilitation during the summer of 1947 to replace the deteriorated concrete in the upstream face and to correct leakage problems, which had appeared shortly after the dam was put into operation. In addition, work was done to improve the stability and thus the safety and the probable life of the dam. The rehabilitation, described in detail by Davis, Jansen, and Neelands (1948b), is summarized here.

The deteriorated concrete on the upstream face of the dam (Figure 30) was

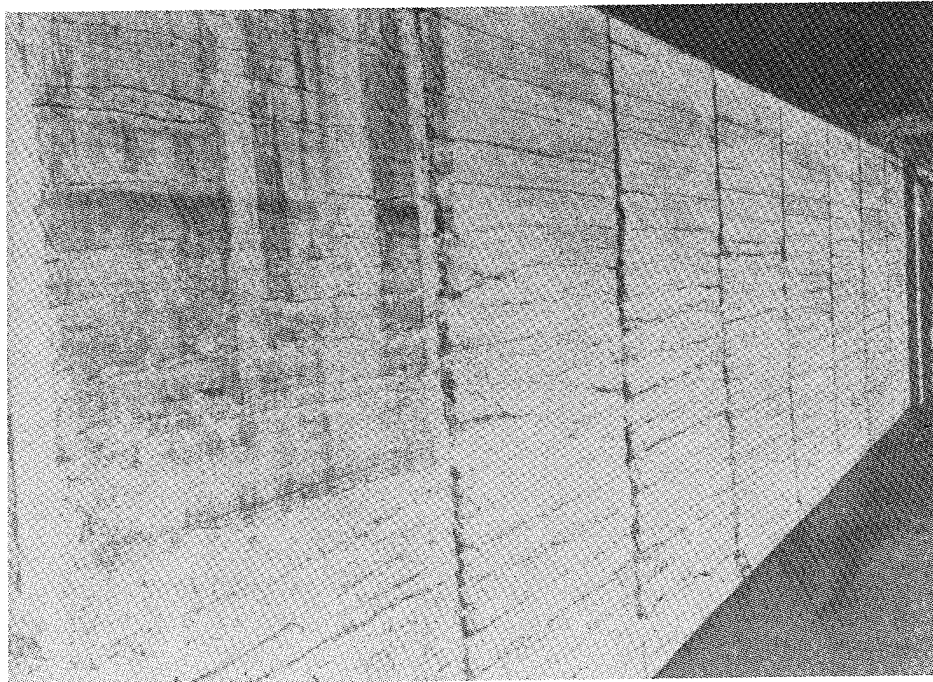

Figure 30. Upstream face of Barker Dam prior to rehabilitation (from Davis, Jansen, and Neelands 1948b)

caused by exposure to approximately 36 years of cycles of freezing and thawing. The reservoir, which is filled in the spring and early summer primarily by melting snow, is drawn down low by winter, leaving the upstream face of the dam exposed. Rehabilitation of the upstream face of the dam consisted of removing the deteriorated concrete, installing precast reinforced-concrete slabs over the entire upstream face, placing coarse aggregate between the dam face and the precast slabs, and then grouting the aggregate to form preplaced-aggregate concrete (Figure 31).

Precast-concrete slabs and preplaced-aggregate concrete were chosen as the repair method for the upstream face of the dam for the following reasons:

- a.* The repair had to be completed during the winter months so there would be no loss of water. The precast slabs and the aggregate could be placed even in severe weather conditions; when the reservoir had filled, the aggregate could be grouted underwater so there would be no danger of freezing.
- b.* The slabs, which would be cast the summer before, could be made of a rich, air-entrained mixture that would be highly resistant to cycles of freezing and thawing. With this protective shell, the preplaced-aggregate concrete could be of low cement content and, therefore, would have low temperature rise during hardening.
- c.* Being precast, the slabs would already have undergone drying shrinkage, and placing them during low temperatures would reduce the likelihood that the mortar-filled construction joints would open later. The slab assembly would provide protection against leakage for the preplaced-aggregate concrete.
- d.* Injecting a grout with a low temperature rise as a continuous operation would eliminate the need for closely spaced horizontal and vertical contraction joints, thus creating a monolithic-like addition to the upstream face.
- e.* Delaying grouting until the reservoir was nearly full would place the dam under the action of water load, thus creating a realistic degree of stress between the new and old concrete. Because of the water load and the low temperatures, the drying shrinkage of the preplaced-aggregate concrete would be about half that of conventional concrete, and the bond of old to new concrete about 50 percent higher.
- f.* The precast panels would not be as expensive as the heavy wooden forms necessary for the placement of conventional concrete. In addition to the expense of material and construction of forms, only green lumber, which would have shrunk and warped after placement, was available.

The 1,009 panels with total surface area of 8,500 sq yd were precast at an upstream site. Each panel was 8-in. thick and varied in size as necessitated by

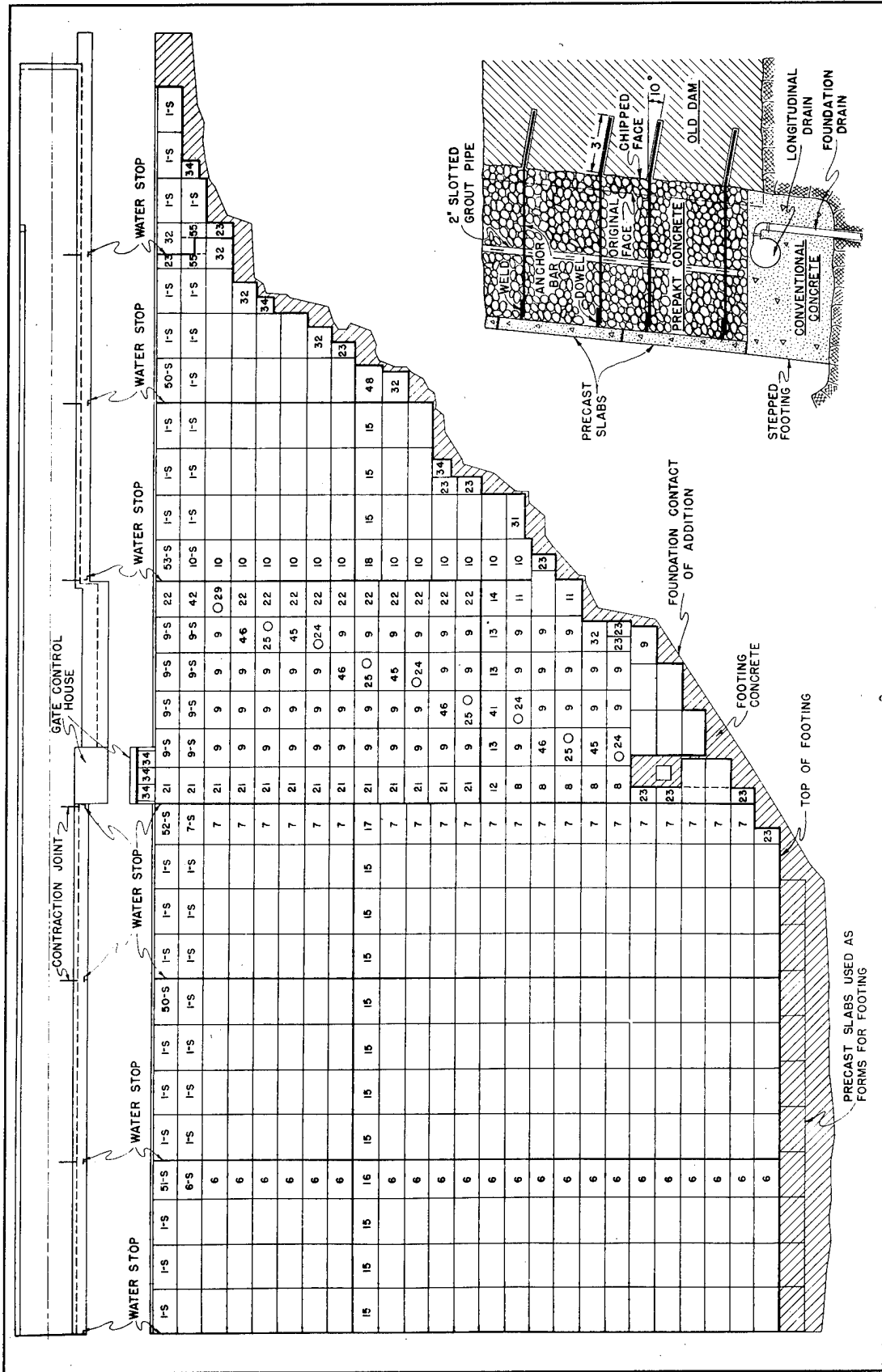

Figure 31. Footing and slab layout, south half of Barker Dam (from Davis, Jansen, and Neelands 1948b)

irregularities in the stepped footing and spacing of contraction joints in the dam. Most of the panels were 6.75 ft wide by about 12 ft long and weighed about 4 tons. Reinforcing mats for the precast slabs were fabricated in jigs to achieve uniformity and accurate placement of the reinforcing bars and steel dowels used to anchor the precast slabs to the upstream face of the dam. All intersections were spot-welded; some were fully welded.

The concrete mixture consisted of 5.8 sacks of cement per cu yd. The aggregate was a mixture of approximately 35-percent sand, 25-percent No. 4 to 5/8-in. gravel, and 40-percent 5/8- to 1-1/2-in. gravel. The net water-cement ratio averaged 43 percent by weight; air-entrainment was about 4 percent. Specifications called for Type II cement, but a few panels were cast with a cement with a composition similar to that of Type IV, and some Type I was used.

The panels were cast on base slabs with wide-flanged beams forming the sides. The concrete was carried from the mixer to the forms in buckets transported with a truck crane. After placement, the concrete was compacted by vibration, and the top of each slab was screeded and then given a rough float finish, except for a 4-in.-wide strip around the edge. This strip was troweled to make grouting the joints easier when the panels were placed.

The panels were removed from the base slabs at 2 to 3 days. To make the separation of panel and slab easier, each concrete base was cast with a 12-in. square chamber that lined up directly below the center of the precast slab. Each chamber was covered by a hydraulic pressure plate set flush with the surface of the base. When the chamber was filled with water, the pressure plate raised slightly, breaking the bond between the precast slab and the base.

The precast panels were moved to a curing yard, where they were stored on pine poles so they would not freeze to the ground. They were cured under continuous water spray, 14 days for those containing Types I and II cement and 28 days for Type IV. Before being removed from storage for placement on the dam face, the slabs were sandblasted to expose the fine aggregate. This step was taken to help ensure maximum bond between the slabs and the preplaced-aggregate concrete.

Before the panels were installed, the upstream face of the dam was chipped to remove all deteriorated and chalky concrete. When only sound concrete was exposed, holes were drilled for the installation of over 6,000 anchors, which would be welded to the dowels in the precast panels. The anchors were embedded to a depth of 3 ft and then grouted; a random sampling of anchors tested under a 25,000-lb load after the grout had hardened revealed no slippage.

A stepped footing of conventional concrete was constructed at the base of the dam. The precast panels and the preplaced aggregate rest on this footing. A flat-bed truck was used to transfer the panels from the storage yard to the damsite. They were lifted from the truck with a crawler-crane and lowered into position on the dam face for installation (Figure 32). Spacer shims

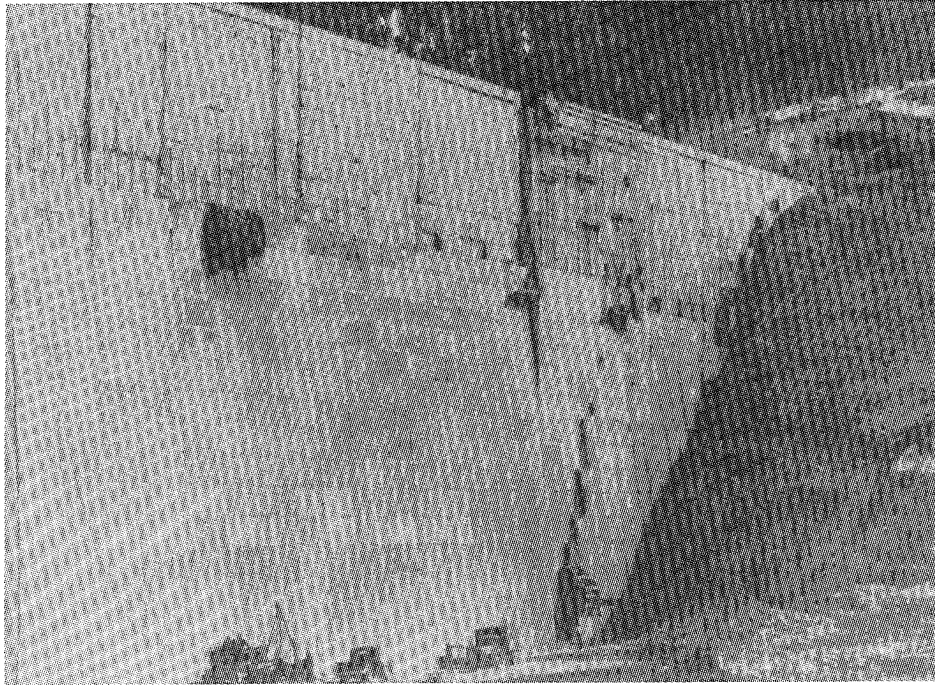

Figure 32. Portion of upstream face of Barker Dam with precast panels installed about three-fourths of its height (from Davis, Jansen, and Neelands 1948b)

helped maintain grade and station and provided suitable joint widths for grouting. As soon as a panel was aligned, with the help of a transit set up on one of the abutments, three dowels on the slab were tackwelded to anchor bars on the face of the dam while the crane was still supporting the slab. Then all dowels were fully welded to anchors. The panels were placed in a pattern so that a vertical joint in each slab was opposite a contraction joint in the old dam. Engineers believed the contraction joints would crack through the preplaced-aggregate concrete to the vertical joints in the slabs. A Neoprene sealing strip was cemented over each vertical joint on the inside face of the slab to prevent seepage.

The next step was to grout the joints. Light-weight muslin was used as joint forms for the upstream face. The muslin was cut into 3-in.-wide strips, which were glued to the slabs. A flat, sharpened nozzle was punched through the muslin for pressure injection of the grout. When the nozzle was removed, the hole in the muslin was plugged with a bit of dry cement. Excess water in the grout seeped through the muslin, thus producing a mortar of low water-cement ratio. The grouting work was performed from scaffolds which were designed to roll along the face of the slabs. One scaffold carried the crew that applied the muslin; another, the grouting crew and equipment. On the downstream face of the slab, the joints were sealed with a stiff mortar, which was troweled into the openings.

On cold days the mixing water was heated so the grout would be pliable enough to completely fill the joint before freezing. The results were that the

joints were even more watertight than expected. When the head of water in the reservoir was 16 ft greater than that of the water in the aggregate behind the precast panels, leakage through the joints averaged about 1 pt per hr per lin ft. This small amount of leakage was attributed to the fact that the slabs were cold and dry--and therefore at minimum volume--when they were placed and grouted.

The panels were erected, and coarse aggregate for the preplaced-aggregate concrete was placed concurrently during the period January-April 1947. Working conditions during this period were generally miserable with bitter cold and high wind velocities. Concrete construction with conventional methods would have been impractical during this period because of the severe weather conditions. The degree of severity of the weather was reflected in rather large daily variations in the rate of panel erection; the average rate was about 12 panels per day with a maximum of 27 panels erected in 1 day.

Aggregate placement generally kept up with panel erection. The best distribution of aggregate sizes was obtained by dumping the aggregate from about 15 ft above the level of aggregate behind the panels. Planks placed across the anchor bars increased scattering and helped prevent chipping of aggregates.

Because of concerns over uplift pressures and no means of reducing or controlling them, a decision was made to begin grouting when the water elevation was 15 ft below the crest of the spillway. Grouting from the bottom of the dam to the top took about 10 days with almost no interruption. During that time, approximately 4,000 cu yd of grout was injected into the aggregate, thus producing about 13,000 cu yd of preplaced-aggregate concrete.

The rehabilitation of Barker Dam was considered successful. For all practical purposes, the high-strength, weather-resistant precast panels and preplaced-aggregate concrete with low cement content provided the equal of a new dam. However, it is believed that precast panels of much larger size would have resulted in additional economies. With heavy construction equipment, panels up to four times the area could be handled without difficulty and erected at about the same rate as the smaller panels (Davis, Jansen, and Neelands 1948a). In addition to reducing the cost of panel erection, larger panels would significantly reduce the total length of joints between panels with a corresponding reduction in the cost of joint treatments.

Gibraltar Dam

Gibraltar Dam is located on the Santa Ynez River north of Santa Barbara, CA. The original dam was completed in 1922 and raised in 1948 to provide storage for the city's municipal water supply. The dam is a constant radius concrete arch dam with a maximum height of 195 ft and a crest length of 600 ft. The thickness of the arch varies from 7 ft at the crest to approximately 65 ft at the base.

The results of a 1983 safety evaluation indicated that the dam did not meet seismic safety standards. Therefore, an RCC buttress was constructed against the downstream face of the dam to alter the dynamic response characteristics of the dam and thus reduce the stresses induced during an earthquake. A drainage gallery system was included in the buttress to collect inflows from the interface, foundation, and buttress drains. A number of alternative gallery construction methods were considered during design of the system. The designer's preferred method involved compacting an aggregate blockout in the three gallery locations concurrent with RCC placement. However, the contractor elected to use precast concrete panels to form the galleries (Figure 33). A 6-in. ledge was saw cut and chipped out along the face of the dam for the roof panels (Klemens 1991). The precast panel system had the advantages that no form or backfill removal was required and the galleries were accessible for drilling foundation drain holes during RCC placement. The precast system had the disadvantages of somewhat higher design and material costs and presented occasional obstacles to RCC placing operations (Wong et al. 1992).

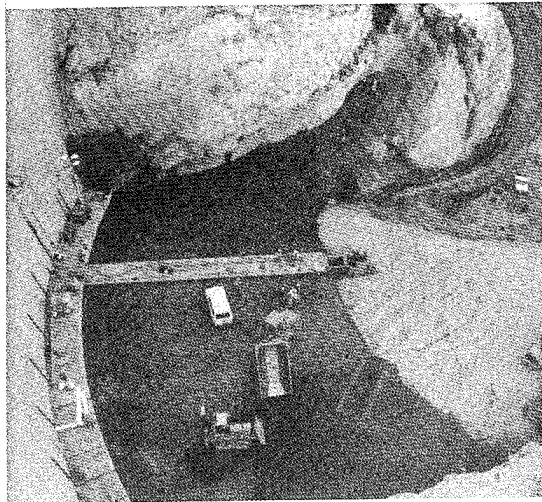

Figure 33. RCC placement around lower drainage gallery panels, Gibraltar Dam (from Wong et al. 1992)

Winchester Dam

As the city of Winchester, KY, continued to grow, so did its demand for water. At the same time, the city was faced with having to repair or breach the two existing dams at the city reservoirs because they had been rated unsafe by the U.S. Army Corps of Engineers. Basing their decision on a study of the two dams, managers of Winchester Municipal Utilities decided to build a new dam. They elected to use RCC and PVC-lined precast concrete panels as stay-in-place forms because of the site and the cost.

The decision to use RCC raised a question about leakage. Seepage rates measured at RCC dams that impound reservoirs have ranged from inconsequential to approximately 2,700 gal/min. Leakage has occurred through lift joints, cracks, and the RCC itself. One of the most reliable methods for decreasing or eliminating this leakage is to use membrane-backed precast-concrete panels as stay-in-place forms on the upstream face of the dam (Moler and Moore 1988).

Located just upstream of the old dam it replaces, the new 1,100-ft-long Winchester Dam consists of a 200-ft-long spillway and a 900-ft shoulder dam. The dam and spillway are 70 ft high and hold more than 1,800 acre-ft of water. The upstream face is vertical; the downstream face slopes 1:1. The dam contains approximately 1,500 cu yd of bedding mixture, 35,000 cu yd of RCC, and 38,000 sq ft of precast concrete panels.

Specifications for the precast panels called for concrete with a compressive strength of 4,000 psi. Each panel measured 4 by 6 ft by 4 in. thick and weighed 3,600 lb. The bottom of each form for the panels was lined with a 65-mil-thick sheet of PVC "T-lock"; the outside surface of the PVC was smooth; the side on which the concrete would be placed had a series of 1/2-in.-high T-shaped ridges to "grip" the concrete. Panels were reinforced with No. 4 reinforcing bars spaced each way on 12-in. centers. Joints were shiplapped and lifting hooks were cast into one edge (*Highway & Heavy Construction* 1985).

A starter slab, constructed in the bottom of the front face of the keyway under the front face of the dam, served as a base for the precast panels. The PVC liner was tied into the foundation by wrapping it under the dam along an RCC layer and then tying it into an RCC cutoff trench in the foundation (Schrader 1985). The panels were stair-stepped into the slopes on each side of the spillway. Soldier beams were attached to the outside of the panels to help with positioning them as they were placed (Figure 34). Where needed, comealongs were used to pull the panels tight (Figure 35). The PVC joints in both directions were heat welded to form a continuous impervious upstream membrane. Panels were anchored with 3/4-in.-diam by 4-ft-long rods screwed into a pair of threaded inserts centered in each panel. The other end of the rods had a 4-in.-sq steel "washer," which was embedded in the bedding concrete and the RCC behind the precast panels (Figure 36). Also, a horizontal flap of the PVC membrane attached to the bottom tier of facing panels was buried in the bedding concrete to prevent leakage through the keyway. Moisture that might seep around the panels was channeled through a 2-ft-diam drain made of coarse granular aggregate wrapped in heavy filter fabric.

The trained crew, heat-welding the lapped splices between the panels and over the anchor bars, was able to keep pace with RCC production on this relatively small dam. However, there is some concern about the cost and rate of heat-welding on a large project (Schrader 1985). Also, there is some concern about the ability of this system to provide permanent seepage cutoff protection because long-term service records for the membranes are not available (Headquarters, U.S. Army Corps of Engineers (HQUSACE) 1992).

Two patents, one for the membrane-backed panels and another for the method of installing the panels, have been issued in the United States. Royalty payments are, therefore, required to use this method in areas where the patent is in force (Hansen and Reinhardt 1991).

Cuchillo Negro Dam

This dam was constructed by the Albuquerque District to provide flood protection for Truth or Consequences, NM. Completed in 1991, the dam is 164 ft high and 643 ft long and contains approximately 75,000 cu yd of RCC. Precast concrete panels were used as stay-in-place forms on the upstream face of the dam. The precast panels, 4 ft high by 16 ft long, were cast with tongue-and-groove connections along the vertical edges. These edges

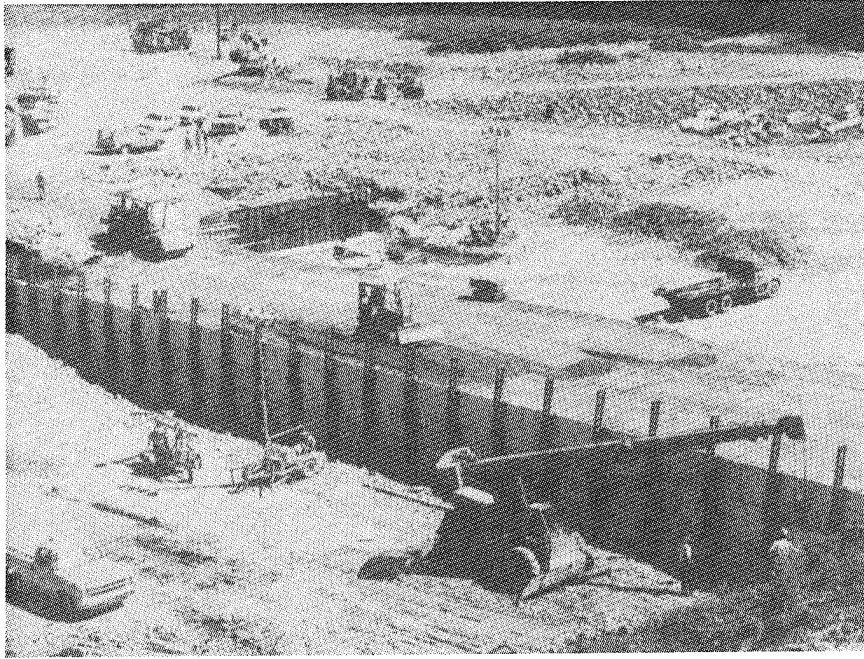

Figure 34. Soldier beams being used to help position precast panels, Winchester Dam (PEH Engineering)

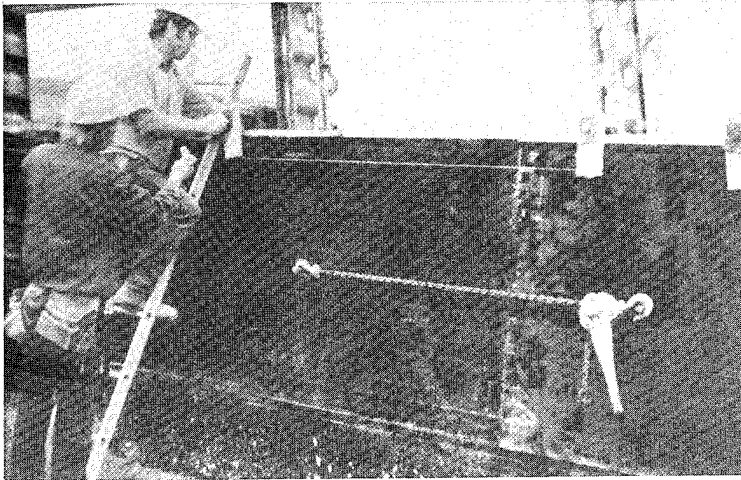

Figure 35. PVC-lined precast panels, Winchester Dam (from Moler and Moore 1988)

interlocked as the panels were installed, producing continuous vertical joints and offset horizontal joints (Figure 37). Each panel was anchored to the RCC with four steel rods. The 6-ft-long anchors with 4-by 6-in. end plates were threaded into sockets embedded in the panels during precasting.

This application of precast panels as stay-in-place forms eliminated the need for erecting and stripping of conventional formwork. Instead, the 600 panels were cast at ground level, which was safer, and stacked individually as RCC placement progressed. Only minimal diagonal shoring was required to resist the pressure of the RCC. These less costly, less labor-intensive procedures were reflected in the contractor's bid price (Gehring 1991).

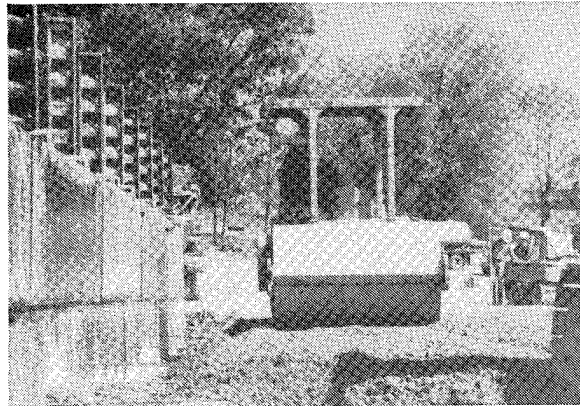

Figure 36. Rods used to anchor panels extend through bedding mixture into RCC, Winchester Dam (PEH Engineering)

Northloop Flood Detention Dams

In the summer of 1982, a series of flood detention dams called the Northloop Project were planned for Austin, TX. These structures were designed to be overtopped during flows in excess of the 100-year-flood event. After thorough study, an RCC section in the downstream portion of the dams was selected as the preferred alternate (Reeves and Yates 1985). Precast concrete panels were used as stay-in-place forms for the downstream face of the RCC section (Figure 38).

Gavins Point Dam

Gavins Point Dam, the smallest of the six Missouri River main stem dams, is located near Yankton, SD. The powerhouse contains three Kaplan turbines, each with a generator rating of 33,333 kW. The average gross head is 45 ft. The power facilities were built in the late 1950s.

The powerhouse and the tailrace slab rest on excavated Niobrara chalk and Carlisle shale. The draft tube portals are part of a massive monolithic concrete placement which is part of the powerhouse foundation. The free-floating tailrace slab is 1-ft-thick concrete.

Rebound of the chalk and shale over the years resulted in an offset and spalling at the interface between the draft tube portal and the tailrace slab (Figure 39). Underwater inspections also identified concrete spalling in the south retaining wall downstream of the powerhouse where it interfaced with the tailrace slab (Figure 40). Erosion of the shale under the tailrace slab had

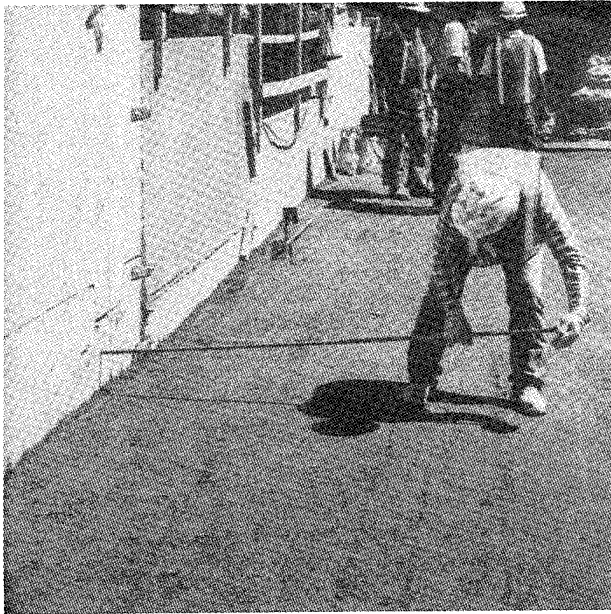
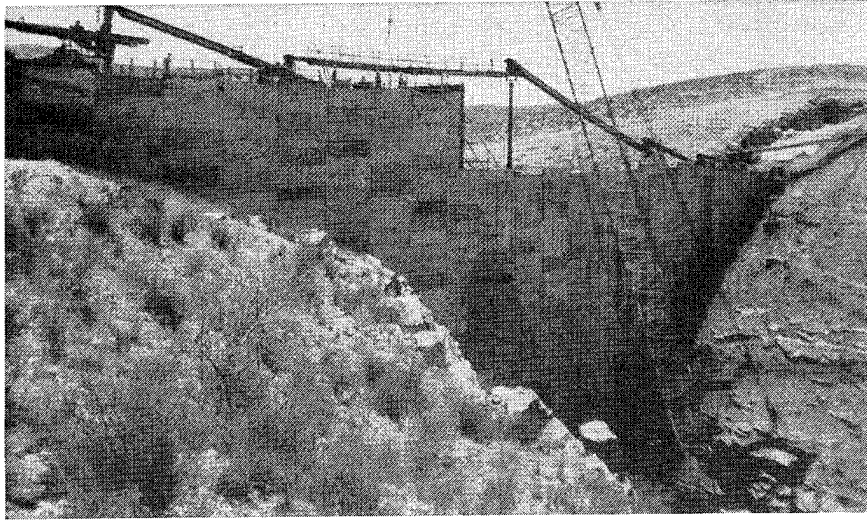

Figure 37. Precast concrete stay-in-place forms on the upstream face of Cuchillo Negro Dam (from Gehring 1991)

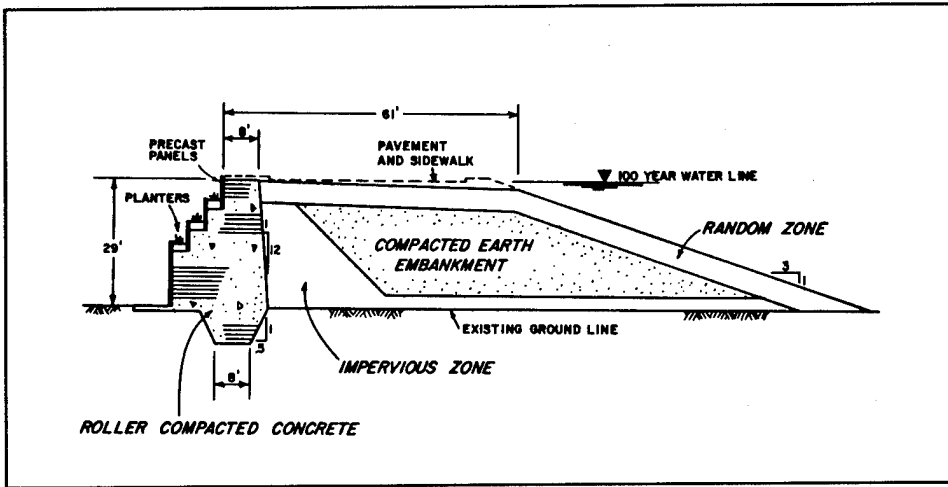

Figure 38. Typical cross section, Northloop Detection Dams (from Reeves and Yates 1985)

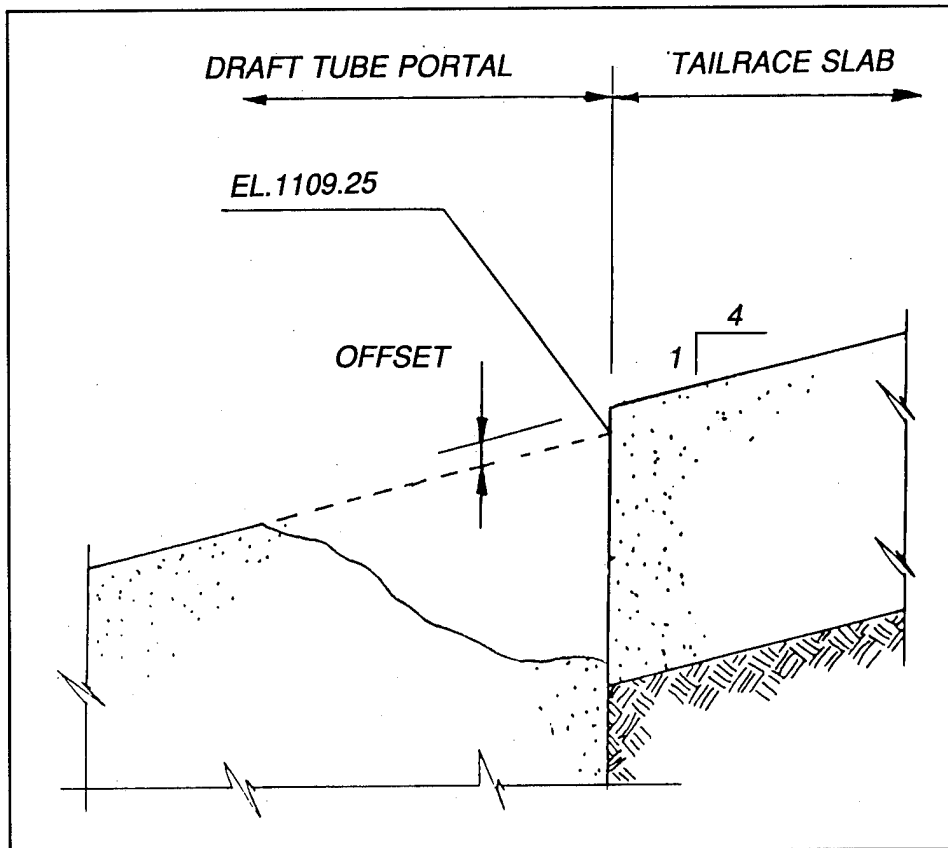

Figure 39. Spall at draft tube portal, Gavins Point Dam (from Harris, Palma, and Miller 1991)

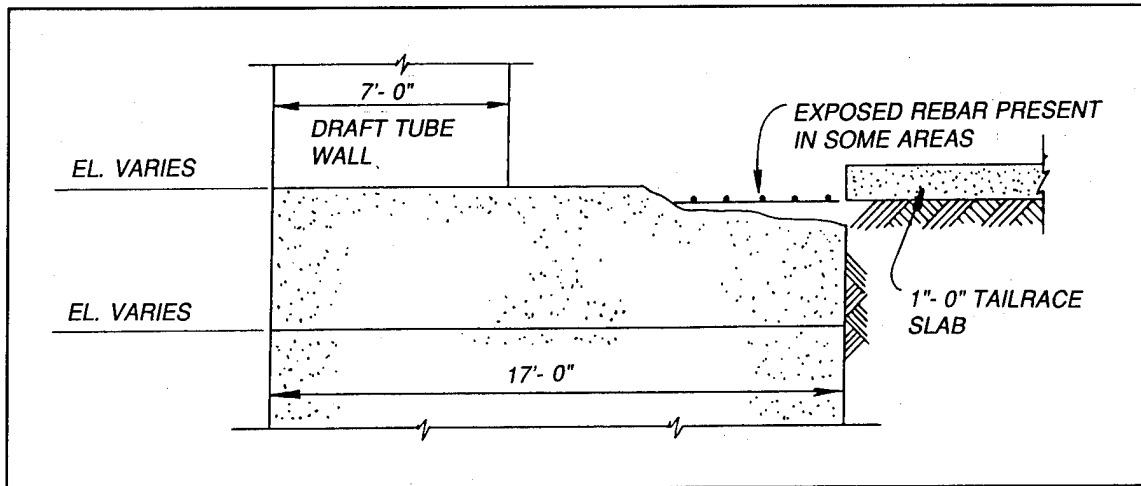

Figure 40. Spall at south retaining wall, Gavins Point Dam (from Harris, Palma, and Miller 1991)

created several voids along the length of the retaining wall. This erosion caused concern that the tailrace slab would be undermined (Harris 1991).

The selection of techniques and materials was the first step in planning repairs. The consensus was that a repair in the dry would be better; however, the cost of building a cofferdam and the lengthy power plant outage during construction were unacceptable. It was decided that the repairs would be made underwater by divers working at a depth of approximately 50 ft.

Before any materials were placed, the spalled concrete surfaces were cleaned of loose or unsound fragments. The spalled areas and the voids were then filled with preplaced aggregate, covered by an anchored form (steel plate or precast concrete panel), and water in the aggregate voids was displaced by injecting prepackaged cementitious grout through holes in the forms. A form was necessary because the grout was placed under pressure. A steel plate was used as a form for the repair made at the draft tube portal (Figure 41). However, the offset between the south retaining wall foundation and the tailrace slab was much larger, approximately 1 ft. To provide for this large offset and for some additional tailrace slab rebound, 15-in.-thick precast concrete panels were used as stay-in-place forms instead of steel plates (Figure 42). Adhesive anchors were used to anchor the precast panels.

The anchors, which were embedded a minimum of 12 in., were installed in a two-step procedure. First, a vinylester resin was used to fill the drill holes approximately half full. Insertion of a vinylester resin capsule displaced the remaining water in the drillhole. The threaded anchor rod broke the two-part capsule, allowing the adhesive to mix without water being present. Results of tensile strength tests on anchors are essentially the same as those for anchors installed in dry holes (McDonald 1990).

The contract called for the power units to be shut down for 14 consecutive days for this repair. All underwater construction was to be completed in this

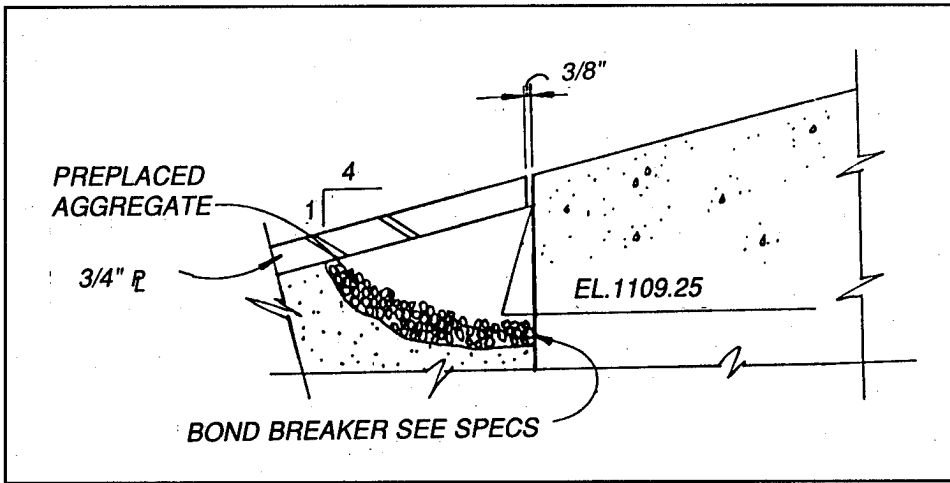

Figure 41. Spall repair at draft tube portal, Gavins Point Dam (from Harris, Palma, and Miller 1991)

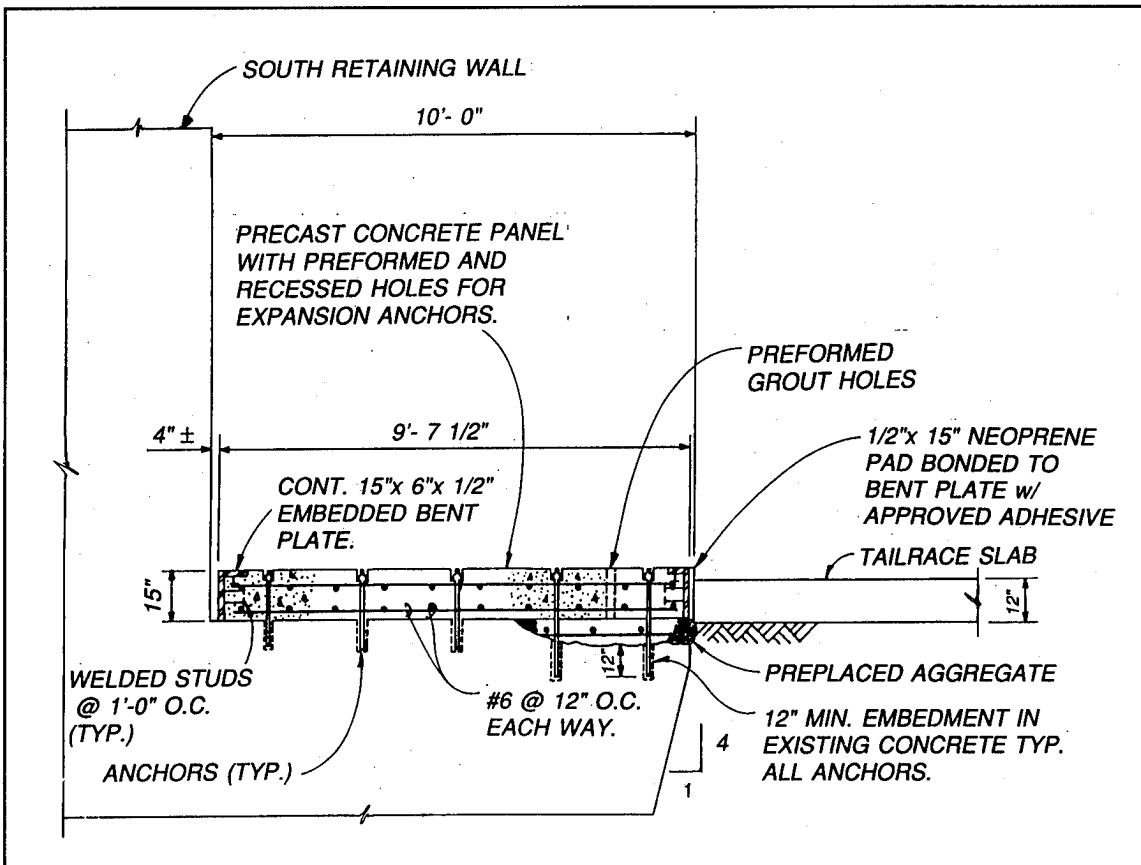

Figure 42. Spall repair at south retaining wall, Gavins Point Dam (from Harris, Palma, and Miller 1991)

time frame. No time extensions were to be granted because of adverse weather conditions. The contractor used several diving crews so work could continue 24 hr a day. Also, each step of the repair was reviewed on land before being done underwater. The project was completed 3-1/2 days ahead of schedule (Harris 1991).

McClure Dam

The Sangre de Cristo Water Company operates three reservoirs in Santa Fe Canyon which supply approximately one-half of the water needed by its customers in Santa Fe, NM. McClure Dam, the largest of the three, is a zoned earth and rock-fill structure with a crest length of 695 ft and a height of 111 ft above the streambed. The dam was designed to be built in several phases, the first being completed in 1926. McClure was raised for the second time in 1946 to its present capacity of 2,616 acre-ft.

A study in 1986 indicated that the capacity of the existing spillway was inadequate to pass the probable maximum flood (PMF). The study also proposed methods that could be used to reconstruct the spillway so that it could pass the PMF without the embankment failing. In 1987, additional investigations were initiated, including geotechnical explorations, preliminary design analyses, and hydraulic model testing of the RCC spillway alternative. Results of these investigations are described by Kraai (1989) and summarized in the following.

The U.S. Bureau of Reclamation's Denver Hydraulic Laboratory constructed a model to test the performance of different configurations of RCC spillways and to evaluate the potential use of the existing spillway structure as a service spillway in conjunction with the RCC emergency spillway. Based on the hydraulic model study, a decision was made to abandon the existing spillway.

One alternative to the RCC spillway was to raise the dam crest with a steel sheet-pile wall. In this concept, piling on the upstream side of the crest would be driven to a depth where the cantilever wall could resist the hydraulic force of the water above the existing crest. This alternative included construction of new reinforced-concrete spillway with a capacity of 16,300 cfs. Preliminary design studies indicated that this alternative was essentially equal in cost and serviceability of the RCC spillway alternative.

Geotechnical explorations revealed that the dam crest was a silt-clay mixture with heavy gravels and cobbles. This finding created concern that the sheet pile would split at the interlocks during driving, thus creating a shortened seepage path with a tendency toward piping. A more acceptable alternative was excavating and backfilling the pile wall to allow verification of joint integrity. Further exploration of the dam crest with a backhoe revealed that the crest material was cohesive and stood vertically to depths in excess of 13 ft. Consequently, it was decided that installation of the pile wall in a trench followed by backfilling with lean concrete was the more desirable

method for construction of the wall. During final design, it was determined that precast, prestressed concrete panels were more economical and potentially more durable than steel piling.

Plans and specifications for both spillway alternatives were prepared to promote competition in the bidding process. Bids, received in March 1988, showed the conventional concrete spillway to be 5 percent more economical than the RCC alternative.

Precast, prestressed concrete panels, 16 ft 6 in. high by 10 ft wide by 8 in. thick, were used to raise the crest of the dam by 7 ft (Figure 43). The panels were installed in the center of a 2-ft-8-in.-wide trench, dug on the upstream side of the dam, 6 ft from the crest. Adjacent panels were connected with steel plates bolted through the concrete panels (Figure 44) to create joints. The joints were sealed with elastomeric gasket material. Upon completion of panel installation, the trench was backfilled with lean concrete (2,500 psi). Construction of the precast, prestressed concrete panel wall went smoothly, and the 650-ft-long wall was placed in only 10 working days.

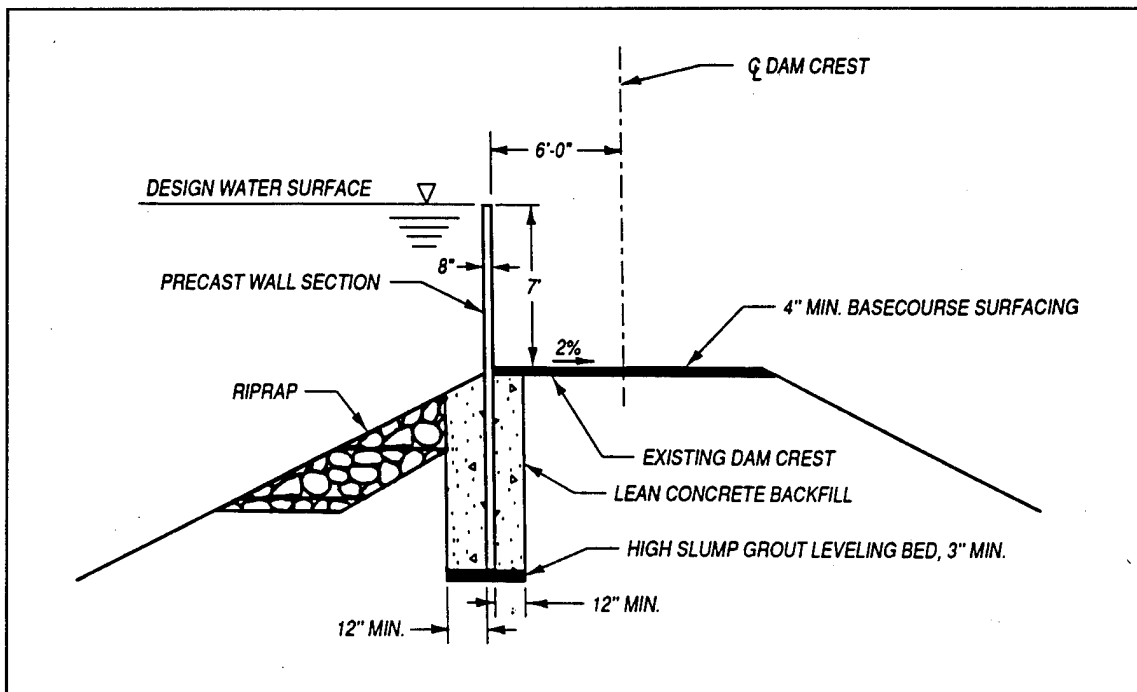

Figure 43. Cross section of crest, McClure Dam (after Kraai 1989)

Lake Sherburne Dam

Lake Sherburne Dam (Figure 45) is a homogeneous earth-fill structure located on Swiftcurrent Creek in north-central Montana near the border of Glacier National Park. The dam was put into service in 1921. Prior to modification, the dam had a structural height of 85 ft and a crest length of 900 ft.

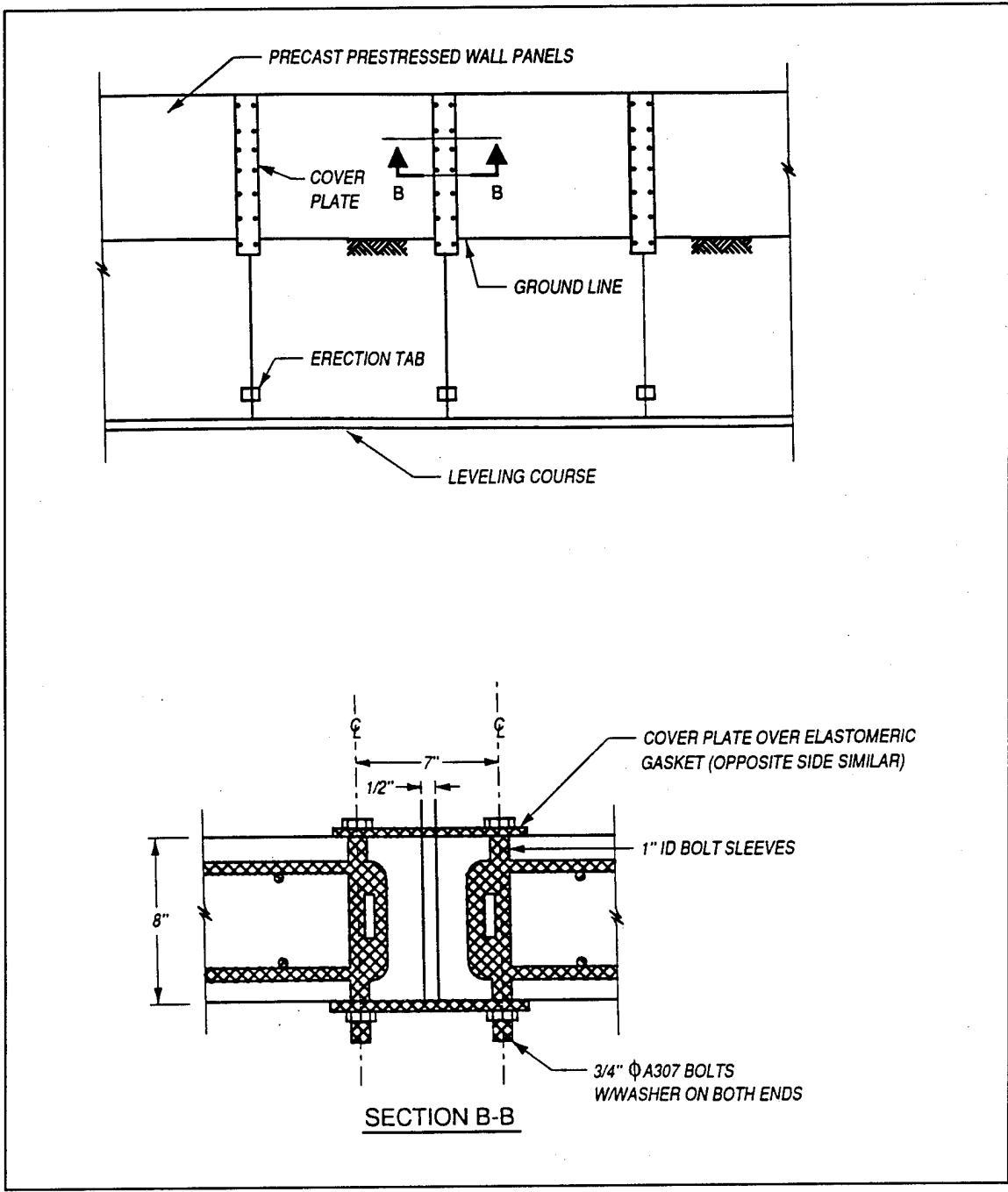

Figure 44. Typical wall elevation and joint detail, McClure Dam (after Kraai 1989)



Figure 45. Lake Sherburne Dam

The original spillway, abandoned because of the instability of underlying glacial debris, was replaced with a temporary wood flume. Two cylinder gates within the outlet works intake tower were used to control the reservoir. Twin tunnels carried flows from the intake tower to the downstream stilling basin. In 1960, the spillway and outlet works were rehabilitated. The cylinder gate intake structure was modified to become a combined spillway and outlet works. The existing cylinder gates were replaced by two high-pressure slide gates. A modified morning glory spillway was added to the intake tower, and the existing weir-type overflow spillway in the left abutment was backfilled with compacted earth. The spillway and outlet works flows were merged near the tower base, and the combined flow passed through the existing twin tunnel structure.

Computations of the inflow design-flood indicated the need for increasing reservoir flood-detention capabilities and evaluating discharge capacity under increased reservoir heads for Lake Sherburne Dam to prevent overtopping and dam failure. As a result of a 1981 proposal to raise the Lake Sherburne Dam crest elevation, the Bureau of Reclamation performed a laboratory hydraulic model study to help determine what the new height of the crest should be and what the discharge capacity of the existing spillway-outlet tower structure under increased reservoir heads would be.

Alternatives considered for mitigation of dam failure consequences were (a) revision of reservoir operating procedures, (b) floodplain zoning for areas downstream from the dam, (c) breaching and abandoning the dam, (d) constructing upstream storage, and (e) modifying existing structures. Modification of the existing structure was determined to be the most effective and least costly alternative for providing protection against dam failure while maintaining project benefits (Duster 1984).

Modifications to the existing structure to prevent overtopping could be accomplished by increasing reservoir discharge capacity, by increasing reservoir storage capacity, or by a combination of both. The most economical solution for Lake Sherburne Dam was to raise the dam crest by 13.5 ft and to continue to use the existing spillway-outlet works.

At Lake Sherburne Dam, raising the crest by adding earth fill over the entire downstream surface of the existing embankment would have required about 120,000 cu yd of earth fill from sources as far as 8 miles away (Figure 46). This design would also require modifying the existing spillway-outlet works stilling structure and would take two construction seasons to complete.

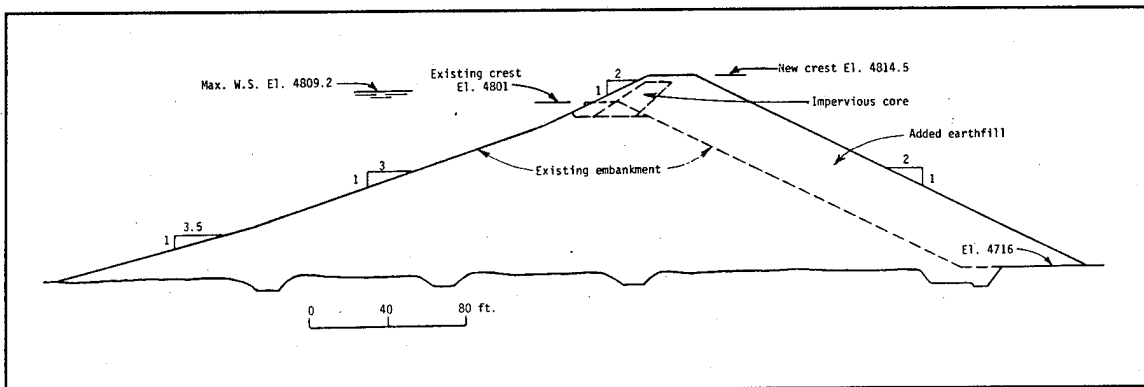

Figure 46. Conventional method of raising dam crest elevation, Lake Sherburne Dam

Raising the dam with a retaining wall system built on the existing dam crest, however, would require only 28,000 cu yd of earth fill, no modification to the stilling structure, and only one season to construct (Figure 47). Based on these advantages and a January 1981 estimated cost of \$3.6 million for the retaining wall construction versus \$5.3 million for the raised embankment construction, the retaining wall system was selected. Building two parallel walls 24 ft apart and filling between them could raise the crest without raising the existing embankment surfaces.

The retaining walls constructed at Lake Sherburne Dam used a patented system known as Reinforced Earth. The system uses interlocking precast concrete panels to form walls which are held in place by 17-ft-long steel strips embedded in earth backfill (Figure 48). The wall foundations were embedded in the fill below the frost line. While several thousand Reinforced Earth structures have been constructed worldwide, none had been used for this

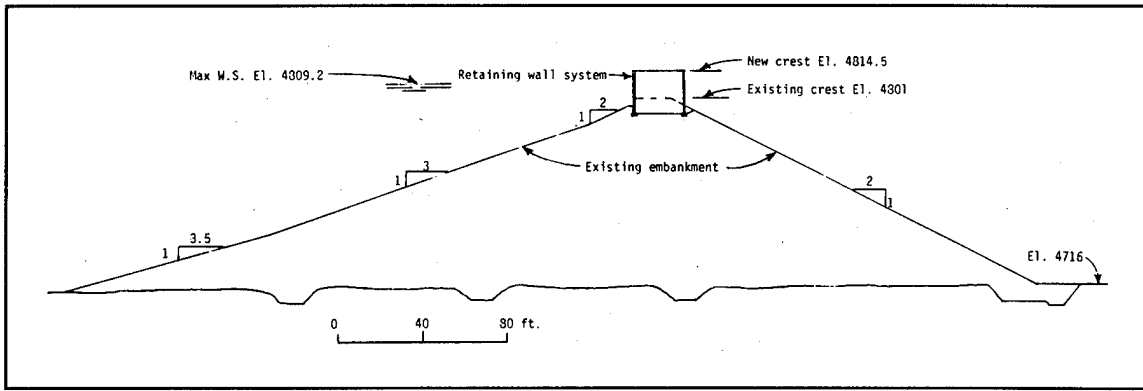

Figure 47. Retaining wall method of raising dam crest elevation, Lake Sherburne Dam

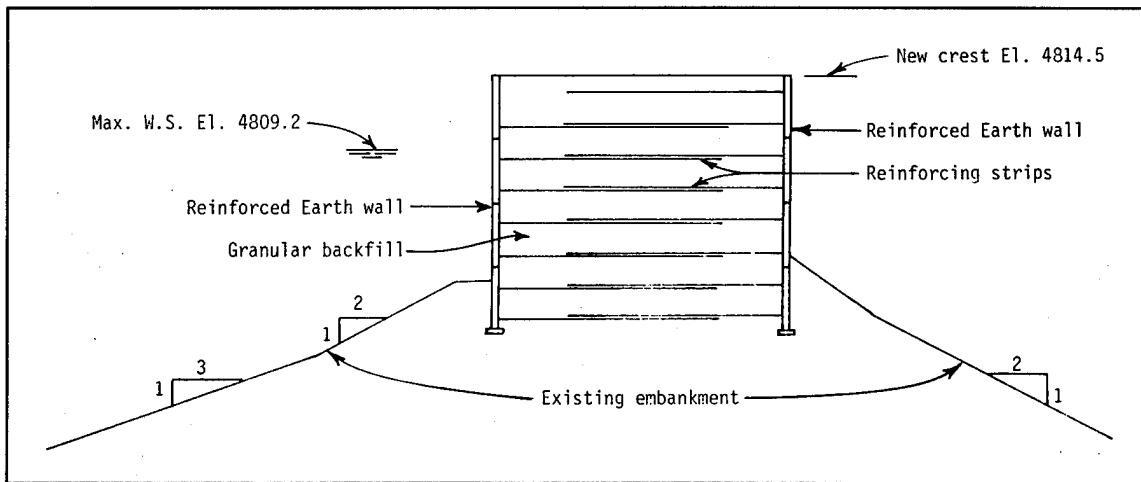

Figure 48. Cross section of Reinforced Earth retaining wall system, Lake Sherburne Dam

application. The Reinforced Earth Company, Arlington, VA, provided the wall system design based on requirements specified by the Bureau of Reclamation. Design considerations included the service life of the new structure as well as loading conditions imposed by the (a) design flood, (b) seepage forces, (c) static loads from the retaining wall system, and (d) dynamic loads from earthquakes.

Properly designed and constructed embankment dams can have a service life of 100 years or more. Because the stability of the Reinforced Earth system depends on metal strips embedded in earth-fill materials, there was concern over possible corrosion of the metal strips that could give the new construction a shorter service life than the remaining service life of the original dam structure. For typical applications, all embedded metalwork for Reinforced Earth structures is galvanized for corrosion protection. At the time of the Lake Sherburne Dam project, however, less than 20 years experience was available with Reinforced Earth structures and a 50- to 100-year service life was desired.

Standard design practice for Reinforced Earth structures using galvanized steel included provisions to control the environment surrounding the buried metal and thus reduce corrosion problems. These provisions included draining the fill and using nonaggressive soils relatively free of clay and organic material. In addition, a significant quantity of sacrificial metal was provided in the design.

Because of the less than 20 years experience with Reinforced Earth structures and because the majority of existing studies of corrosion rates for buried metals did not address the embedment of metal in two dissimilar materials (soil and concrete), designers looked for options to better assure a long service life. Among the options considered were providing cathodic protection, insulating the connection between the metal embedded in soil and the metal embedded in concrete to reduce the potential for corrosion, and using an epoxy coating on all reinforcing components embedded in soil or concrete to reduce the potential for corrosion.

While cathodic protection was considered the most effective method, it was also the most expensive and difficult method to install. Providing an insulated connection would require the special manufacturing and field installation of an insulating device. Epoxy coating was chosen as the most practical option for corrosion protection since the coating could be factory applied at a cost only slightly higher than that for galvanizing. In the relatively benign exposure of this project, epoxy coating of reinforcing components should expand the structure's service life extensively with little added expense.

Construction of the modification began in July 1982 with excavation of the upper part of the existing embankment. Panel placement began after completion of the excavation, drainage pipe installation, and placement of the leveling pads for the Reinforced Earth walls. Over 48,000 sq ft of Reinforced Earth walls were constructed between early August and completion of the work in November 1982.

Construction of a Reinforced Earth wall consists of a relatively simple procedure that requires standard construction equipment and methods. The first row of precast panels is set in place on the leveling pad, and backfill is spread and compacted behind the panels to the first level of reinforcing strips. The reinforcing strips are then attached to the panels, and additional backfill is spread and compacted over the strips to the next level (Figure 49). This sequence is repeated until the wall construction is completed. External bracing of the first row of panels is necessary; however, succeeding rows are held in place by clamping and wedging the panels against the previous row. A strip of waterproof membrane placed over the joints and zoning of earth-fill materials between the two walls solved seepage problems.

The modification has not been in place long enough to determine its long-term durability. In terms of economy and speed of construction, the project was a success.

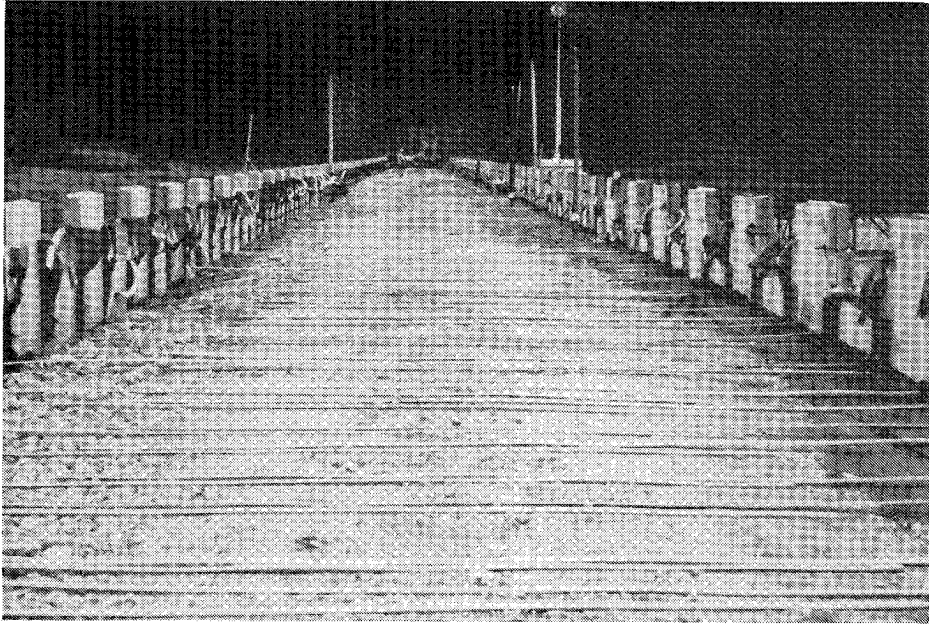

Figure 49. Precast panels held in place by metal strips embedded in earth, Lake Sherburne Dam

A deciding factor in the choice of the retaining wall system was the time required for construction, less than 5 months, thereby allowing construction to be completed in one season. This short construction period greatly reduced the impact on project operations, which were restricted during portions of the construction. The more conventional method of raising the dam by adding embankment would have required two construction seasons and would have restricted reservoir operations during two irrigation seasons.

Total contract costs for the modification were approximately \$1.6 million, significantly less than original estimates. About 65 percent of the cost was for materials and construction associated with the Reinforced Earth structure. The modified dam is shown in Figure 50.

Googong Dam

The Googong Dam, located in a short gorge section on the Queanbeyan River about 6 miles upstream of the city of Queanbeyan in New South Wales, was constructed to form a reservoir to supplement the potable water supply for Canberra and Queanbeyan. The dam, which is operated and maintained by ACT Electricity and Water, was completed in 1978. The main embankment, 1,148 ft long and 203 ft high, consists of a nonsymmetrical, filter-protected clay core covered with rock-fill shells (Himsley 1991). A 407-ft-long, concrete-lined spillway is located at the northern end of the dam. The overflow section of the spillway converges to 203 ft in the chute. About 2,625 ft north of the main dam is a 39-ft-high, earth-fill, saddle embankment.

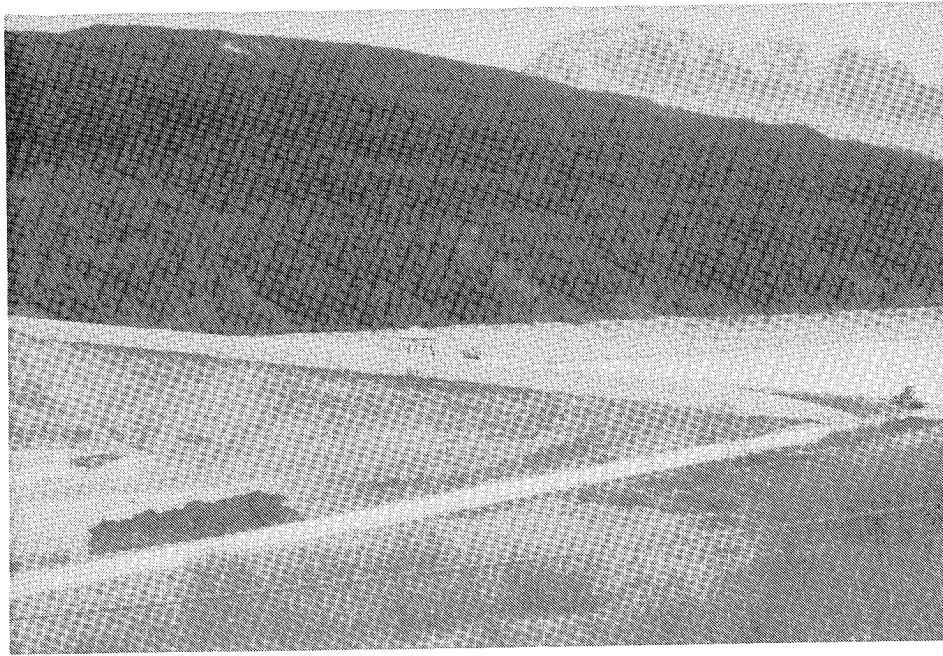

a. Downstream face

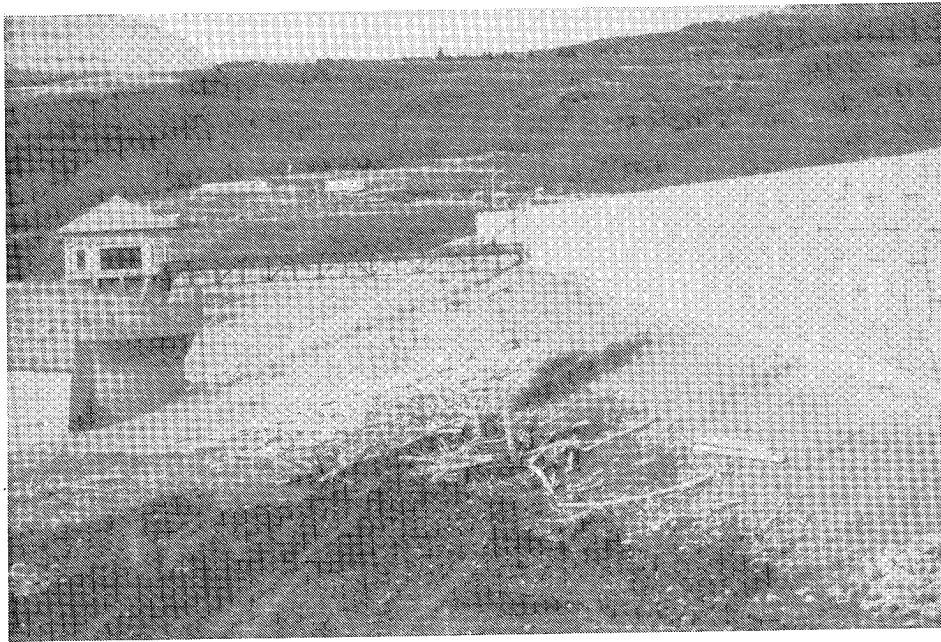

b. Upstream face

Figure 50. Lake Sherburne Dam following modifications

A water intake tower with access bridge and water outlet facilities complete the structure (Figure 51).

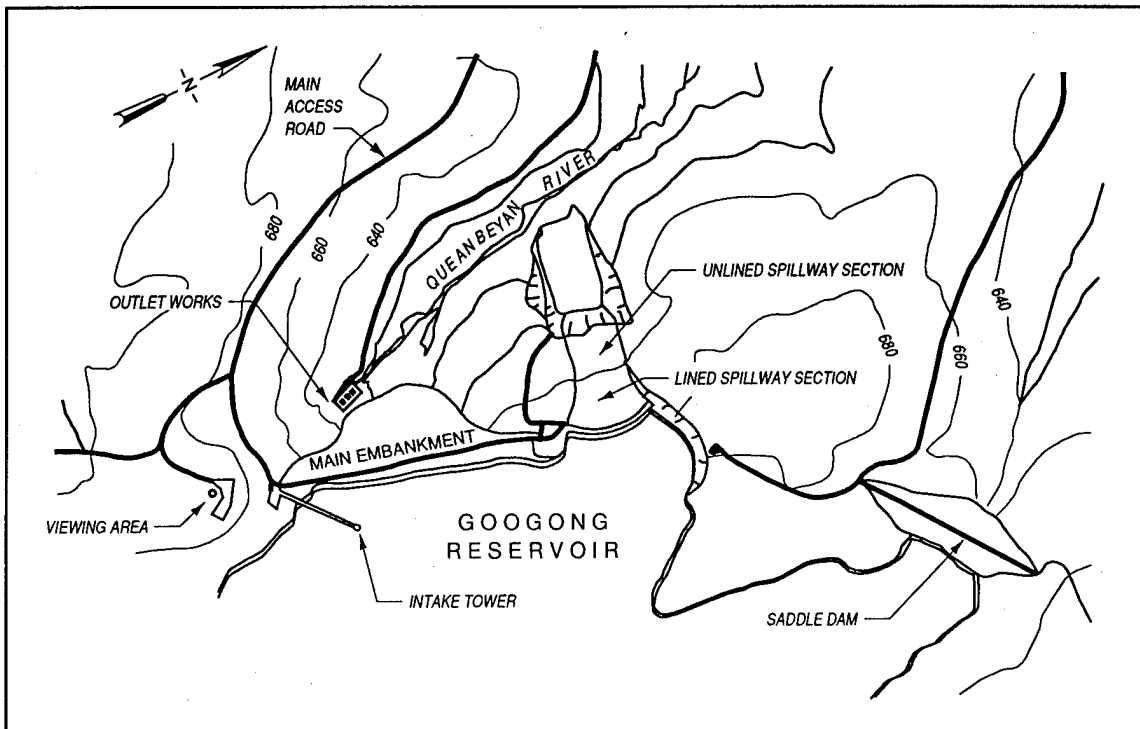

Figure 51. Layout of dam and appurtenant structures, Googong Dam (from ACT Electricity and Water 1991a)

Instruments for monitoring deformation, settlement, and leakage were installed in the dam. To date there have been no records of abnormal performance. The dam and appurtenant structures are in excellent condition. However, the dam needed modification because the spillway was inadequate to pass the revised PMF outflow. If the dam failed because of overtopping, there would be significant loss of life as well as economic loss in millions of dollars in damages (ACT Electric and Water 1991a).

Alternatives for modifying the dam included:

- a. Raising the existing main saddle embankments 1.5 ft; both conventional, buttress-fill techniques, and a "reinforced-earth friction-anchored retaining wall" were proposed as possible methods for raising the dam.
- b. Constructing a secondary, 180-ft-wide, uncontrolled spillway over the existing saddle embankment and raising the existing dam embankments 13 ft with concrete retaining walls or reinforced earth.
- c. Constructing a secondary, 427-ft-wide, fuse plug spillway over the existing saddle embankment and raising the existing dam embankment 8 ft with concrete retaining walls.

Additional alternatives considered too costly or impractical included widening the existing spillway and building a secondary spillway at a location other than that of the saddle embankment.

The final decision was to discharge the PMF outflow through the existing spillway section and raise both the main and saddle embankments 15 ft to accommodate the increased outflow (Himsley 1991). Also, it was decided to strengthen the ogee crest section of the spillway with posttensioned anchors and stabilize the unlined portion of the spillway chute. Reinforced earth with exterior precast concrete panels tied from side to side with plastic straps would be used to raise the main dam (Figure 52), and compacted earth fill placed against the downstream face would be used to raise the saddle dam.

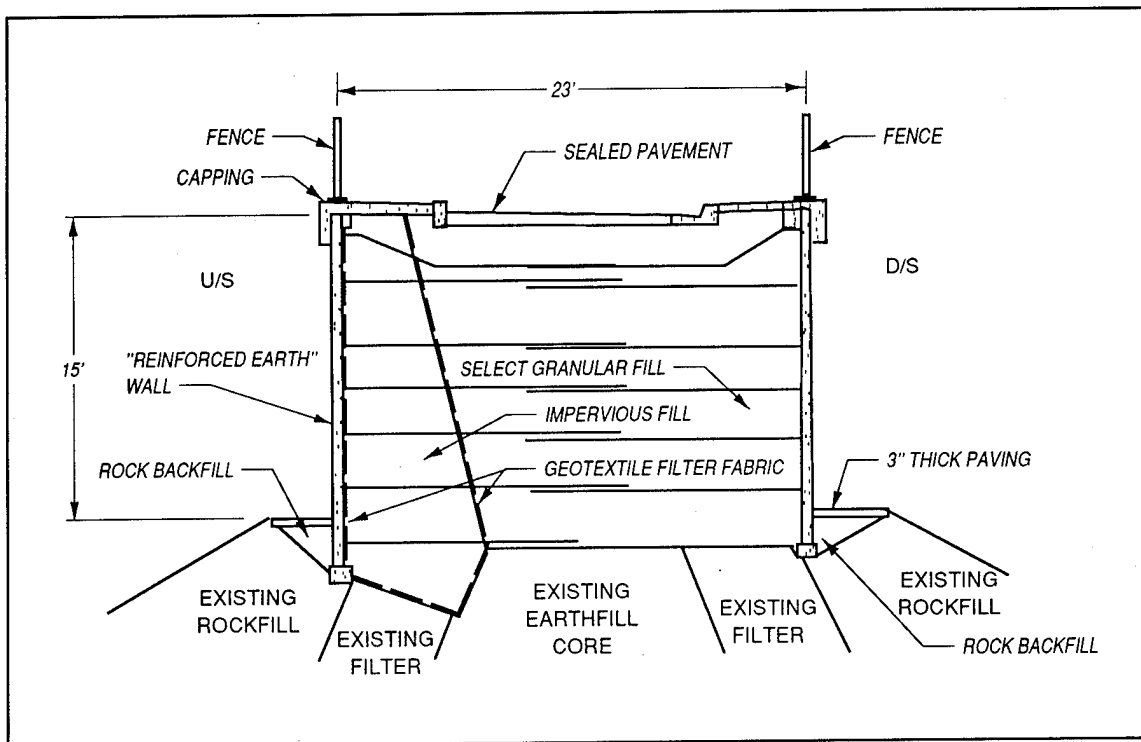

Figure 52. Typical section, Googong Dam modification (after Himsley 1991)

This alternative was chosen because it cost less than a conventional buttress fill, it required a shorter construction period, and it would not interrupt the use of the reservoir for supplying water. In addition, it was concluded that this system would allow for future deformation of the embankment, would not have a negative effect on the stability of the main dam, and would last at least as long as the original dam (ACT Electric and Water 1991a).

The first step in raising the main embankment was to extend the northern end of the dam and to prepare a footing for the precast panels (Figure 53). Rock fill for the extension was transported in two highway dump trucks, spread by traxcavator, and rolled with a vibratory roller. At the same time, the pavement was stripped from the top of the existing embankment, and then the road base and top filter layer, which were kept for use as granular fill,



Figure 53. Upstream and downstream footings for precast panels, Googong Dam

were excavated. The footing for the panels was constructed of unreinforced concrete (ACT Electric and Water 1991b).

A V-shaped trench was excavated into the core at the top of the existing embankment, geotextile filter fabric was placed, and the trench was filled with a layer of zone 1 material. The material was spread with a backhoe and compacted with a vibratory padfoot roller. Only minimal excavation had to be done on the abutments because their foundation is rock; the V-shaped trench was not needed.

The subcontractor for the precast panels set up a precast yard in Queanbeyan for construction of the wall panels. The concrete for the panels had a specified strength of 3,640 psi and maximum aggregate size of 3/4 in. Cylinders for monitoring concrete strengths were tested daily by a registered laboratory. The results were well above the specified strength because the subcontractor elected to use a higher strength, 4,640 psi, mixture to facilitate early stripping and lifting.

A jig was used for construction of the panels to ensure uniformity. Nominal dimensions of standard panels were 6.6 ft wide by 5.3 in. high by 6.3 in. thick. Anchor loops for the cables were cast into the panels; the number of loops varied from two to six per panel. Because of the differences in height and slope of the upstream and downstream walls and different requirements

for corner panels, 121 different types of panels had to be cast; a total of 1,528 panels were used. Completed panels were stockpiled at the precast yard.

The first tier of panels had to be erected with an accurate degree of inward lean to compensate for the outward movement that would occur when the fill material was placed and compacted. To ensure the correct alignment, the panels were clamped together and propped from both sides (Figure 54). Subsequent tiers were supported on resin-bonded cork packing while the vertical joints were filled with closed-cell, expanded polyethylene foam strips. Higher tiers of panels were clamped together (Figure 55) and then pushed into alignment with timber wedges.

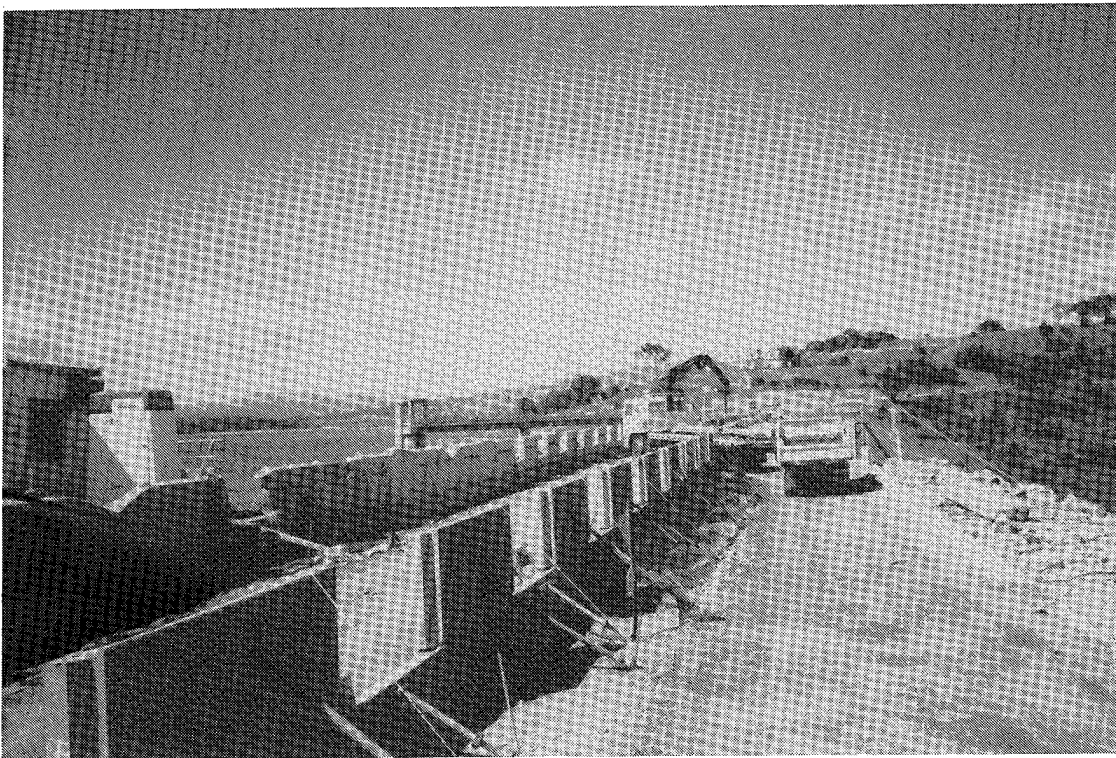

Figure 54. First tier of panels, Googong Dam

The incorrect internal placement of some of the timber wedges resulted in discontinuity of the foam filler; the results could be some loss of fines from the granular fill. Wedges were not removed as the wall was raised; when the work was completed, some of the wedges could not be removed. Some long-term timber staining could be the result.

The precast panels are held together with straps made of 10 polyester fiber bundles enclosed in a polyethylene sheath. Plastic was chosen over galvanized steel because the straps pass through a layer of clay fill placed against the upstream wall. The panels are held in place by friction that develops between the fill and the straps. Straps were spaced vertically at 31 in. As the fill material reached each strap layer, the straps were laid out from wall to wall

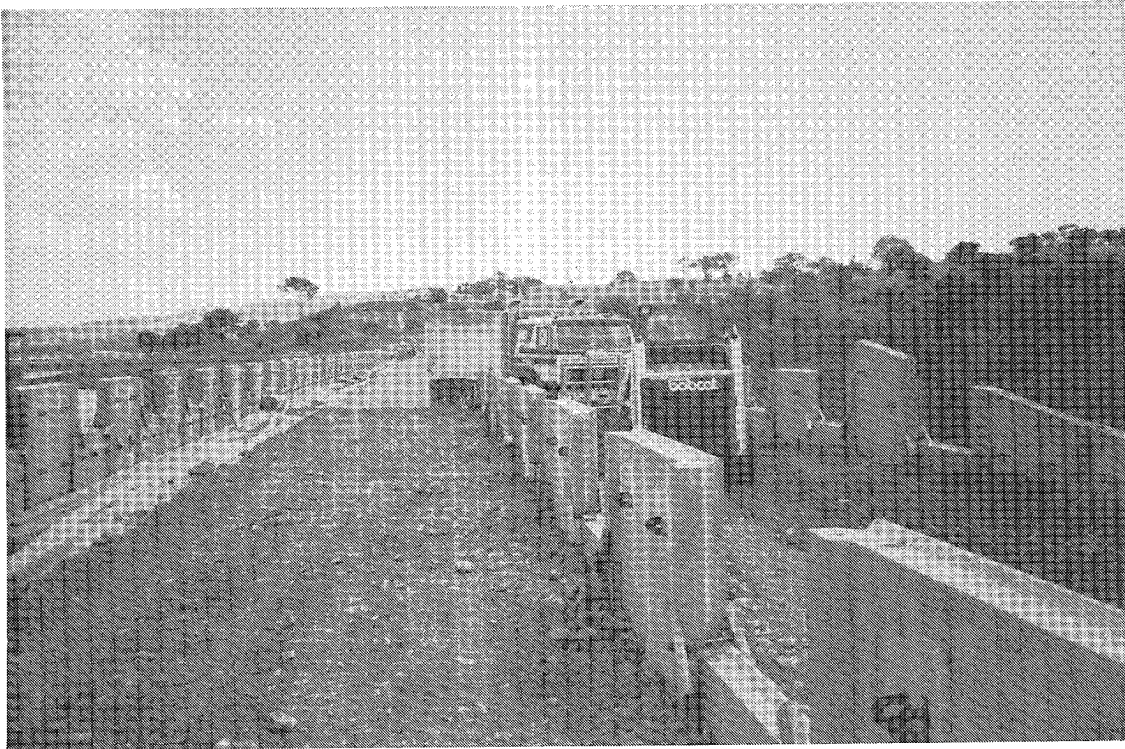

Figure 55. Precast panels clamped together during placement of granular fill, Googong Dam

and then fitted around the toggle bars as they were pushed between the anchor loops. The straps were then pulled tight by hand, and the area was filled with select granular fill and compacted. This procedure was repeated until the wall was complete.

Despite this procedure of attaching and covering the straps a layer at a time, some straps were damaged. Damaged straps were not replaced unless more than 2 of the 10 bundles of polyester fibers were exposed. Damaged areas of the polyethylene coating were sealed, and the sealed area was wrapped with geotextile filter fabric. The limited time frame for preparing and covering a short section of strap did not allow for the type of inspection that could determine the extent and severity of this type of damage.

Two persons were designated to check the line and plumb of the panels as they were being installed and the fill placed. Even so, a final vertical check confirmed some panels were out of specified tolerance. Also, during the setting-up of the panels, some cracking and spalling occurred when the corners of two panels came into contact. Some ongoing maintenance may be required, depending upon the amount of movement that occurs between adjacent panels. The recommendation that a gap be cut between panels already in contact was rejected.

The most serious problem during erection of the panels was the damage to the coating on the anchor loops in the precast panels. A min of 0.1 in. of

coating was specified to provide adequate corrosion protection; however, a check showed some anchors had less than 0.08 in. and had to be rejected. Further, it was discovered that severe damage had occurred to the coating on some anchors when the panels were being stacked in the precast yard, when they were being erected, and when the fill was being compacted. Even minor knocks or squashing caused extensive damage. Contractors first tried to repair the damage by applying another layer of the same coating. This attempt failed as the two coats did not bond. Next, they used a different type of coating and a primer; inspection indicated the primer provided a bond between the two coatings. Inspection and repair procedures were established; however, the inspection process was time consuming and tedious. Some damage, such as hairline cuts, was difficult to detect. Because of the number of anchor loops used, it is highly likely that a reasonable number of damaged loops have been undetected. Also, damage that occurred after compaction was not detected.

Panel erection began on 2 November 1991 and was completed on 25 February 1991. Once installation of the precast panels was complete, the tops of the panels were capped with precast L-shaped units anchored to backing concrete behind the panels. Hot-dipped, galvanized, safety fencing was installed on top of the L-shaped units. Replacement of the roadway completed the raising of the main dam.

The entire project was completed in early 1991 at a cost of nearly \$6 million. The cost for raising the main embankment 15 ft to a finished crest length of 1,388 ft was approximately \$2,500,000.

Blue Ridge Parkway Dams

Bass Lake, Price Lake, and Trout Lake are located in the National Park Service's Blue Ridge Parkway near Blowing Rock, NC. The earthen dams at the three lakes range from 28 to 40 ft high at the maximum sections and from 270 to 530 ft long at the crests.

During a national dam safety program, a Bureau of Reclamation evaluation of the flood routes of the three lakes indicated all three of the dams would overtop during the PMF or inflow design flood. Overtopping heights were calculated to be from 1.9 ft at Bass Lake Dam to 4.1 ft at Price Lake Dam. It was estimated that maximum overtopping flows at embankment toes could range from 22 ft/sec at Bass Lake Dam to 26 ft/sec at Price Lake Dam. Without protection, the dam crest and the downstream slopes could be severely eroded. Wooten, Whiteside, Welsh, and Wirkus (1993) described the steps taken to provide overtopping protection for the three dams. This case history is a summary of their report.

The major modification at each dam was to rebuild or flatten the downstream slope of each embankment and provide overtopping protection. A cellular concrete mat (CCM) system was selected for overtopping protection because of its successful performance in full-scale model tests under flow

velocities up to 26 fps and the anticipated lower cost compared to other types of overtopping protection. The design of the CCM protection systems for all three dams was based on full-scale model tests (Hewlett, Boorman, and Bramley 1987; Clopper and Chen 1988), and on literature from the discussions with CCM vendors. RCC protection systems were also designed as an alternate construction option at Price Lake and Trout Lake Dams.

CCMs, also referred to as articulated concrete blocks, were originally used to protect coastlines from wave erosion. A CCM system is constructed by tying precast concrete blocks together with polyester rope or steel wire cables and then anchoring them to the embankment (Figure 56). The blocks are from 4 to 9 in. thick and 1 to 2 ft sq. Each block is formed with holes for the cables and an opening, or cell, all the way through it. All mat systems use rope or cables to link the blocks longitudinally; some also use lateral cables. Before the CCMs are placed, the embankment is covered with a geotextile filter fabric. Water can pass into and out of the embankment

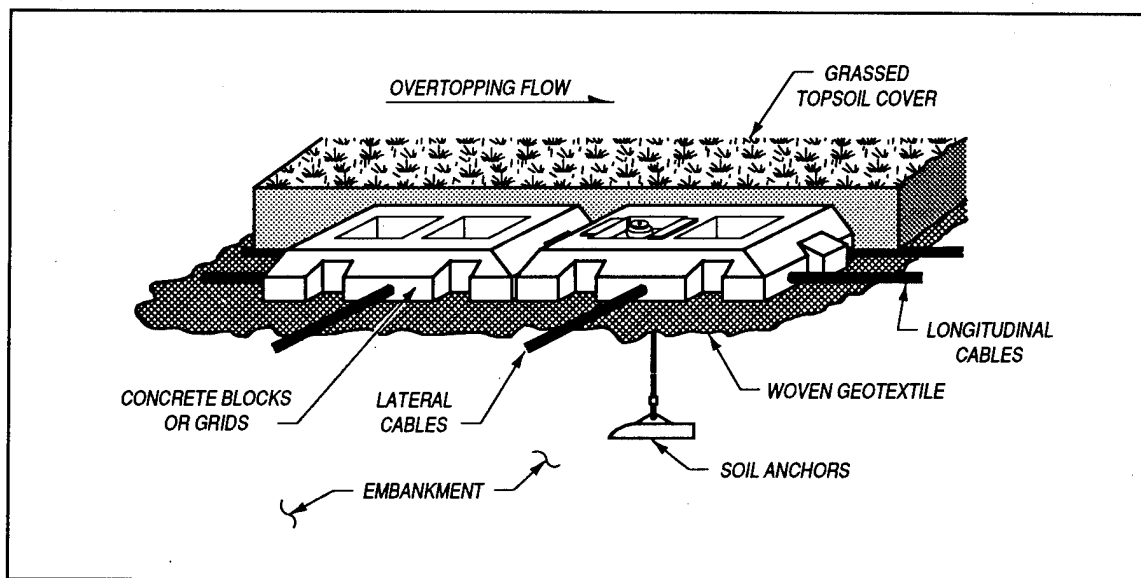

Figure 56. Schematic cutaway of cellular concrete mat system, Blue Ridge Parkway Dams (from Wooten et al. 1993)

through the fabric and the cells in the blocks. These openings can be filled with topsoil and planted with grass to increase embankment protection.

Five general contractors bid on the dam modification project, and all bidders proposed to use the CCM systems instead of RCC. Apparently, the bidder's estimated costs for the RCC system were not competitive because of the project's small scale and the requirement to use CCMs at Bass Lake. The engineer's estimated costs and actual bid prices are tabulated below. These costs include CCMs, anchors, geotextile, anchor trench excavation and back-filling, and seeded topsoil. CCM coverage was approximately 8,600, 2,700, and 3,000 sq yd at Bass Lake, Price Lake, and Trout Lake Dams, respectively.

Dam	Costs, \$ per sq yd (1989 dollars)			
	Engineer's Estimate	Winning Bid	Bid Range	Bid Average
Bass Lake	\$72	\$45	\$24-\$64	\$50
Price Lake	\$78	\$47	\$24-\$69	\$62
Trout Lake	\$73	\$47	\$36-\$67	\$55

Based on discussions with the contractor after construction, a unit cost of about \$55 per sq yd would more accurately reflect the contractor's costs including associated overhead and profits.

Before the CCMs were placed, the downstream slopes of the dams had to be rebuilt. CCMs were then placed on the dam crest and the downstream embankment to the toe at all three dams. At Bass and Trout Lake Dams, CCMs were used to form an apron that extends 40 ft beyond the embankment toe. Reinforced concrete was specified for the apron at Price Lake Dam because of the possibility of flows exceeding 26 fps; no data were available to determine how well CCMs would perform in flow velocities of that magnitude.

The general construction sequence for placing CCM systems was to (a) prepare slope and anchor trenches; (b) place the filter fabric; (c) place the CCMs; (d) tie the CCMs together with splices; (e) anchor the CCMs; (f) fill in spaces in the CCMs at anchor points, splices, and structures with grout; (g) backfill anchor trenches; (h) place the topsoil cover over the CCMs (1-in. depth); and (j) maintain the topsoil by establishing grass growth.

A concrete block plant 65 miles from the project site made the CCMs. The blocks were formed in a typical cellular concrete-block mold and then joined with polyester cables into 8- by 40-ft mats. The mats were moved to the dams in flatbed trailers. A crane with a spreader bar was used to place the CCMs on the slopes, which had been covered with the filter fabric. The CCMs were carefully aligned across the slopes, and the aluminum sleeves used for the lateral splices were hand crimped. Helical anchors were installed through anchor points on 4-ft spacings along the top and 8-ft spacings along the toe and sides. Anchor installation was accomplished with a bobcat with a hydraulically driven anchor-installation attachment. To provide space for installing and connecting the anchors, a block was left out at each anchor point on the sides of the mat and a space of approximately 8 in. was left between upper and lower CCMs (Figure 57). Anchors were also placed at splices. Grout was used to fill the anchor spaces in the CCMs, and compacted fill was used in the anchor trenches.

Because of a steeper grade transition, the downstream side of the crest at Bass Lake Dam required additional anchoring. Duckbill anchors, which did not require any block removal and grouting, were used.

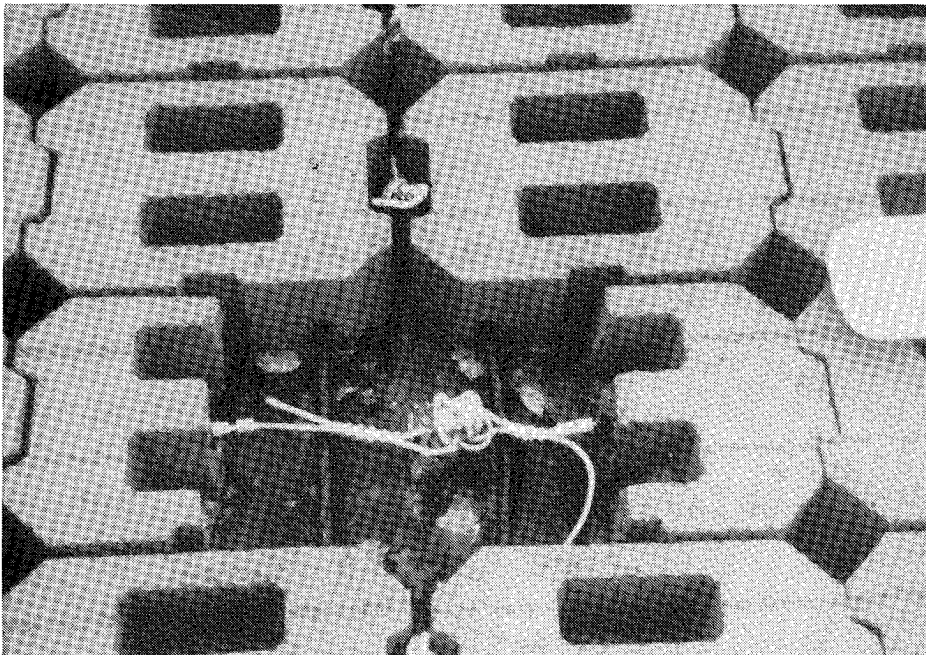

Figure 57. CCM anchor point and lateral seam between mats, Trout Lake Dam

After the CCMs were installed and anchored (Figure 58), they were covered with topsoil to a depth of 1 in. and seeded with grass. The contractor was responsible for maintenance of the soil cover until the grass was established.

Modification of all three dams was accomplished concurrently during the period from October 1989 to June 1991. Approximately 14,300 sq yd of CCMs were placed during the period October-December 1990. This project is believed to be the first application of CCMs for overtopping protection of embankment dams in this county, and results indicate that this technique can provide cost-effective remediation for small- and medium-sized dams. Several design considerations were suggested based on construction experiences at the Parkway dams:

- a. Determine the cost effectiveness of CMMs compared to alternative protection methods for specific project sizes and locations.
- b. Determine whether the specifications for the blocks present any special difficulties of local concrete plants.
- c. Specify that grade changes must be gradual and emphasize this requirement to the contractor.
- d. Simplify slope geometry as much as possible.



Figure 58. CCMs prior to placing topsoil cover, Trout Lake Dam

- e. Design lateral and longitudinal cable strengths based on the reduced strengths at cable splices.
- f. Specify measures to reduce erosion of slope soil from beneath CCMs during construction. On existing dams or spillways where slope grading is not required, consider placing the CCMs directly on the existing topsoil and grass.
- g. Require testing of a representative number of soil anchors to verify capacities.
- h. Evaluate specifying the use of duckbill anchors on slope grids. Ease of installation and attachment to the CCMs may justify the extra expense of this anchor compared to helical anchors.

Wilkerson Lake Dam

Precast cellular concrete mat (CCM) was used in 1992 by the Savannah District to provide overtopping protection for Wilkerson Lake Dam, a compacted earth-fill dam at Fort Gordon, GA (Figure 59). CCMs are precast concrete blocks tied together to form mats. Typically, the blocks are from 4 to 9 in. thick and between 1 and 2 ft sq. They are cast with holes through which the joining cables are passed and with center openings called cells to permit ingress and egress of water.

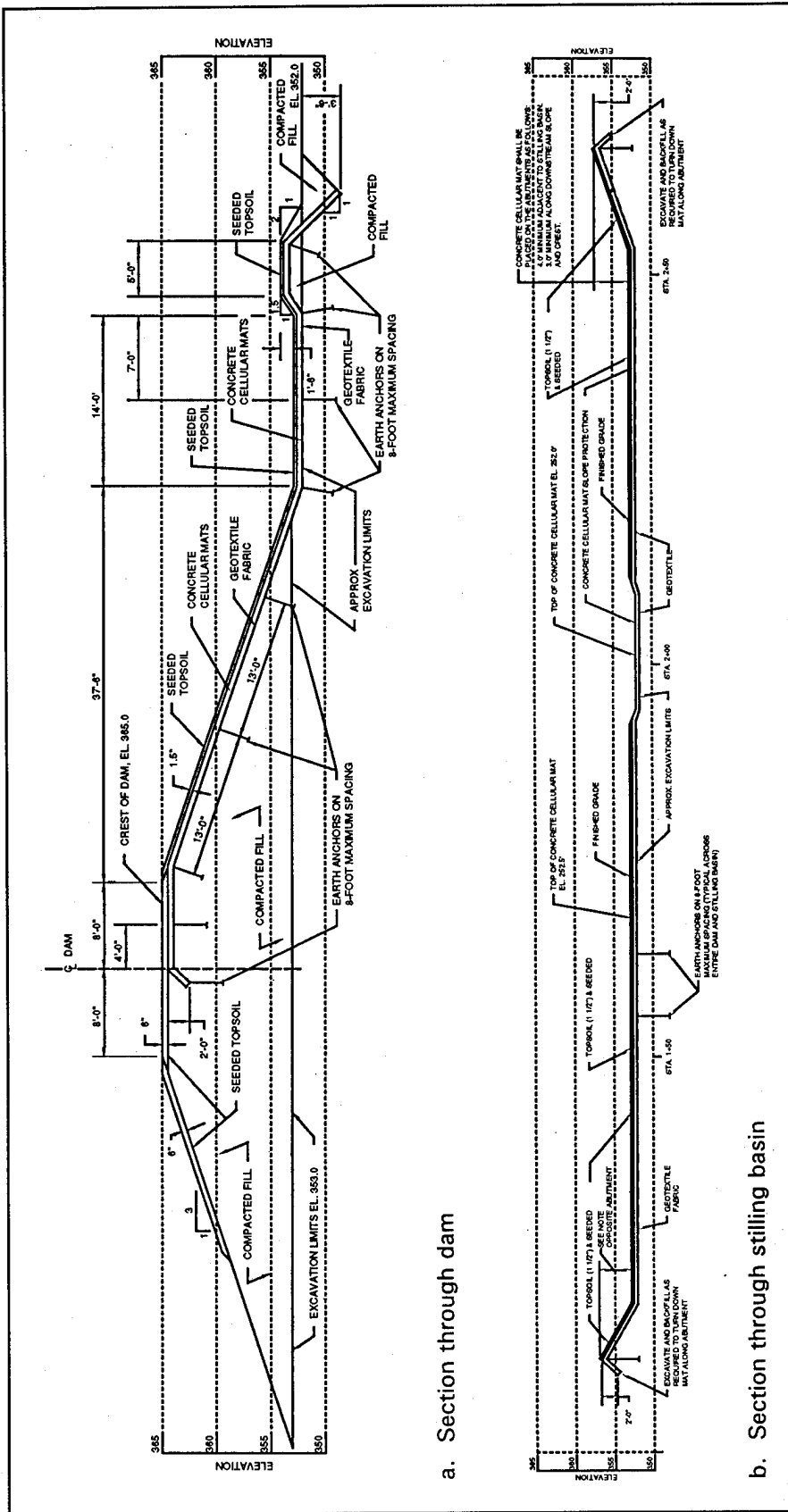

Figure 59. Typical sections, Wilkerson Lake Dam

All areas to receive CCMs were excavated and shaped to specifications. Wet, soft, and loose material was removed, and earth fill containing cracks or gullies was replaced. Next, geotextile filter fabric was laid over the entire area. The blocks were placed on the filter fabric, which prevents erosion of the soil.

A homogeneous mass of consolidated, no-slump concrete was used to cast the blocks, or grids. Aggregate used in the mixture was graded in accordance with ASTM C 33 (1991) with the maximum size being 3/8 in. Specifications for the concrete included a minimum compressive strength of 4,000 psi at 28 days, a minimum unit weight of 130 lb/cu ft, and 5-percent maximum water absorption. Physical specifications for the grids included a minimum weight of 45 lb/sq ft with minimum and maximum open areas of 15 and 35 percent, respectively. During casting, a set of three grids was taken from each day's pour. One grid was tested for compressive strength, water absorption, and specific weight at 7 days; the other two, for compressive strength at 28 days.

The grids were tied together with revetment rope to form mats; the maximum allowable width and length of each mat were 8 and 50 ft, respectively. The revetment rope consisted of high-tenacity, low-elongating, continuous filament, polyester fibers within an outer jacket. The minimum breaking strength of the ropes used in assembling the mats at the casting yard was 6,000 lb; ropes used to combine mats onsite had a minimum breaking strength of 2,750 lb. Longitudinal ropes were looped at one end of the grid and the two ends run through holes cast in the block. At the other end, the two sections of rope were spliced to form another loop; a protective sleeve was placed over the splice. Lateral ropes extended 6 in. from the grid. Photographs of the CCM installation are shown in Figures 60-63. A backhoe was used to lift and place the mats. Placement of the mats started at the downstream limit and proceeded up the slope. As mats were placed, they were secured to adjacent mats with the loop and rope extensions. Lateral ropes on the edges of the mat system were fastened with buttons. Gaps 2 in. wide or wider were filled with structural grout (Figure 62).

Earth anchors were used to secure the CCMs to the soil. Specifications called for 5-ft-long anchors with 5,000-lb resistance for the upstream edge of the mat; 4-ft-long anchors with 3,500-lb resistance for those located at the downstream toe and within the apron; and 3-ft-long anchors with 2,500-lb resistance at other locations. At the upstream edge, the longitudinal loops were used to fasten the mats to the anchors, which were located at a maximum lateral spacing of 4 ft. The remaining anchors were spaced at a maximum of 8 ft laterally. Trenches for anchoring the edges of the dam were backfilled with impervious fill and compacted.

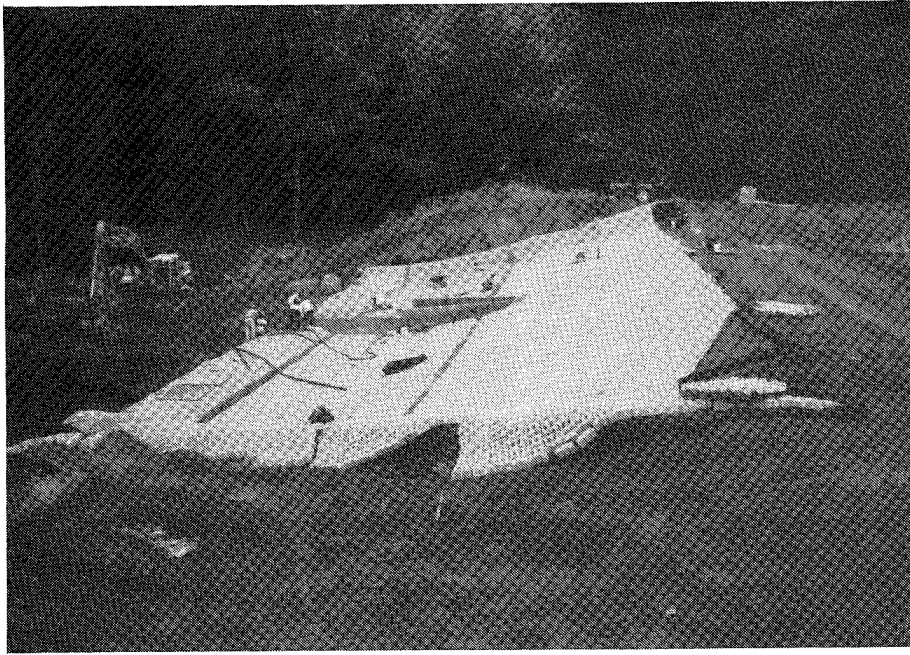

Figure 60. CCM and geotextile filter fabric placed up to crest of dam, Wilkerson Lake Dam



Figure 61. Placement of CCM along crest, Wilkerson Lake Dam



Figure 62. Earth anchor installation on downstream slope, Wilkerson Lake Dam

The CCMs were filled and covered with 1-1/2 in. of seeded topsoil on the slope and apron and 6 in. on the crest (Figure 63). Traffic on the CCMs, before and after being covered, was limited to 3/4-ton trucks, small tire-mounted backhoes, farm-type tractors, and tractor-mounted lawn mowers.

Vischer Ferry Dam

Vischer Ferry Dam, completed in 1913, is located on the Mohawk River near Albany, NY. The dam consists of two concrete gravity overflow sections which link each riverbank to an island. The average height of the gravity sections is approximately 40 ft. A broad-crested weir, 3 to 6 ft high, is located on the upstream end of the island. The combined length of the three dam structures is 1,919 ft. The dam was rehabilitated in 1990 as part of an overall redevelopment of the project to expand the powerhouse and increase generating capacity from 5.6 to 11.6 MW (Sumner 1993).

As part of the rehabilitation, the existing river regulating structure was moved to provide for construction of the expanded powerhouse. The replacement structure is situated perpendicular to the dam so that it discharges from the left side of the new intake. The upstream end of the relocated regulating structure forms the intake entrance of the forebay. A hydraulic model of the forebay area showed that head loss and the potential for water separation could be reduced significantly if a contoured pier nose was added at the upstream end of the regulating structure.

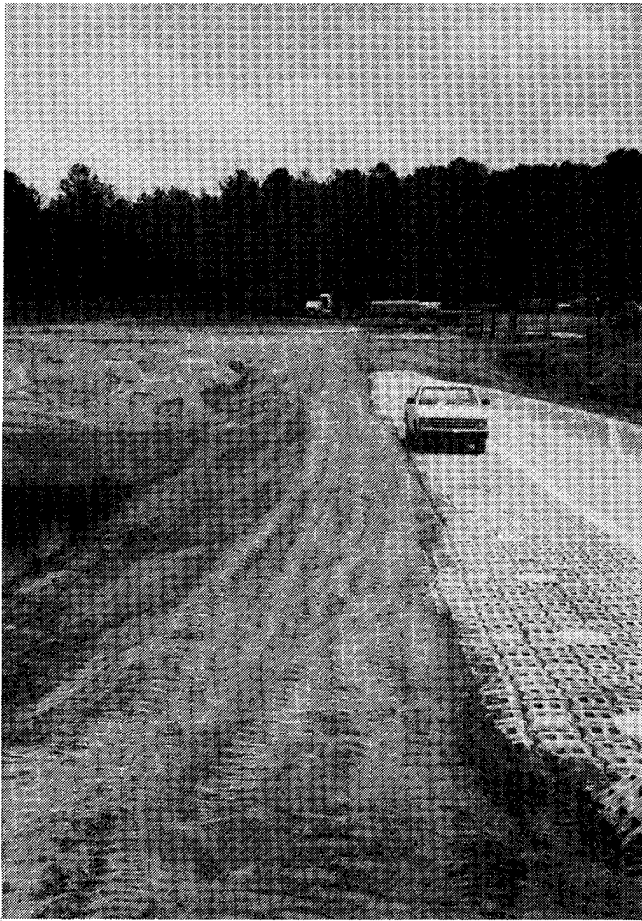

Figure 63. Completed CCM installation on crest of dam prior to placement of seeded topsoil, Wilkerson Lake Dam

The original design for the pier nose was based on cast-in-place concrete inside a dewatered cofferdam. However, the bid cost for the cofferdam alone was \$250,000, so the project team discussed alternatives and decided to use stacked, precast concrete sections and tremie concrete infill (Figure 64).

The design of the precast section was based on the following: the physical dimensions of the existing structure and the results of the hydraulic model study, ice and barge impact loadings, and construction and installation costs. A local casting plant cast the panels with recessed lifting eyes, sleeves for the spud pipe-guide system, and inserts for reinforcing dowels.

Placement of the precast nose sections (Figure 65) and tremie concrete required approximately 7 working days. The first section was positioned and leveled with jack posts, and sandbags were placed around the perimeter of this segment. Concrete was tremied to the top of this section and cured for 4 days. During the curing time, divers installed guide angles and reinforcing

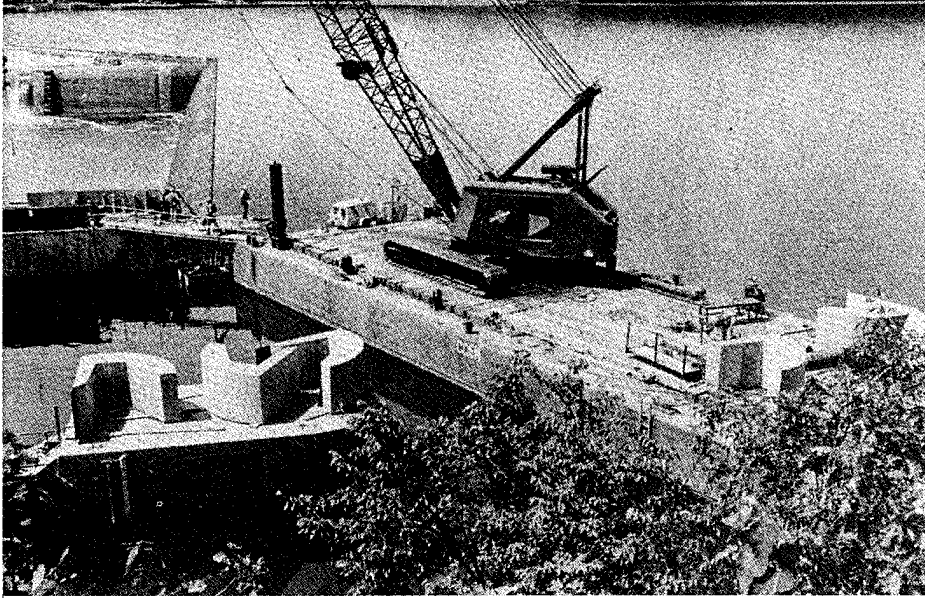

Figure 65. Precast pier nose sections ready for installation, Vischer Ferry Dam (from Sumner 1993)

dowels into the existing pier and spud pipes into the first section. Then, precast sections 2 through 6 were set, and temporary intermediate connections were installed to resist plastic concrete loads during the second placement of tremie concrete. Joints larger than 1/2 in. between the precast sections were sealed. Tremie concrete was placed to elevation 219.5 at a placement rate that did not exceed 10 ft per hr. The last step was to form and place the cap slab. The precast sections and the existing pier are connected through tremie concrete, reinforcing, and dowels.

Construction of the rounded pier nose with precast concrete and tremie concrete (Figure 66) resulted in a savings of \$160,000 (Sumner, Nash, and Haag 1991). In addition to reduced construction time and costs, this method effectively eliminated the potentially adverse impact of cofferdam construction on river water quality.

Chauncey Run Checkdams

As part of the overall rehabilitation of the Hornell Local Flood Protection Project, two checkdams were constructed on Chauncey Run. The check dams are located just upstream of the flume that conveys flows to the Canisteo River.

The original plan was to use cast-in-place gravity dams with fully paved stilling basins. However, architect-engineer estimates in the 30-percent design submission indicated the use of precast components could reduce the cost of the structures by 50 percent. In addition, the control afforded by precast plant

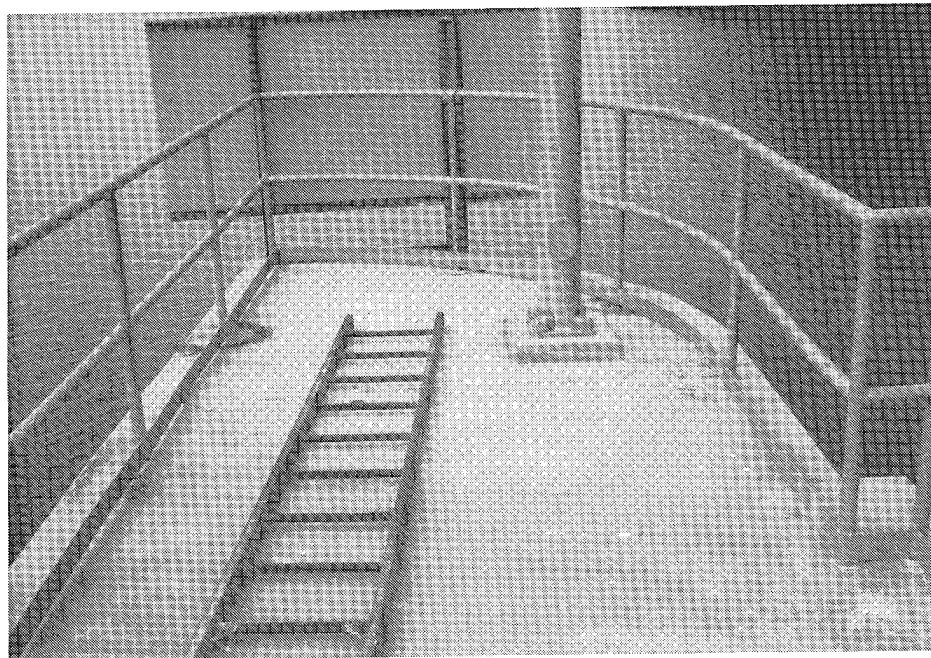
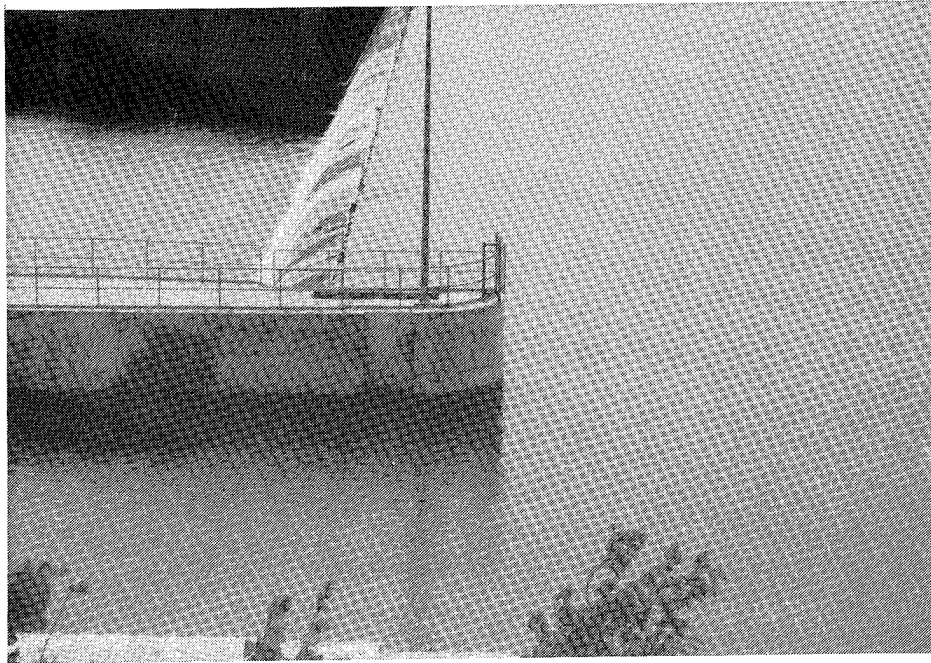

Figure 66. Completed pier nose section, Vischer Ferry Dam

conditions would assure high-quality materials (Allen 1991).¹ Therefore, the Baltimore District elected to use precast concrete components for construction of the dams.

Precast concrete crib units were used to form the abutments, which were then filled with gravel. The checkdams are specially designed precast planks supported by precast concrete posts embedded in the rock foundation (Figure 67). A cast-in-place concrete sill keyed into rock created the stilling basin downstream of the checkdams. The use of precast components made it possible to easily maintain flows during construction, and the appearance of the new structures was well-suited to the site (Figure 68).

C-1 Dam

Lock and Dam C-1 is located on the Champlain Canal near Troy, NY. A two-stage rehabilitation of the dam's seven tainter gate piers was initiated in 1993. In stage I, a cellular cofferdam was constructed to enclose piers 5, 6, and 7. Following dewatering, the counterweights for each tainter gate were removed and placed on temporary supports immediately downstream of the gates. The steel tainter gates were then removed for refurbishing, and the existing concrete gate piers were removed down to the original foundation. Precast concrete units were used to reconstruct the gate piers (Figure 69).

The reinforced-concrete units were fabricated by the Fort Miller Co., Inc., in their Schuylerville, NY, precasting facility. The reinforcement was Grade 60, epoxy-coated reinforcing steel. The concrete mixture used in precasting was proportioned with 1/2-in. maximum size aggregate for a 28-day compressive strength of 7,000 psi. Mixture proportions for a 1-cu yd batch of concrete were as follows:

Material	Amount
Portland cement, Type II	752 lb
Silica fume	52 lb
Fine aggregate	1,110 lb
Coarse aggregate	1,560 lb
Water	241 lb
Air-entraining admixture	12.1 oz
Water-reducing admixture	112.6 oz

Except for the nose units (Figure 70) and the butt units which were cast as individual segments, most of the precast pier units consisted of three or four integrated panels (Figure 71). Fabrication tolerances for lengths of the units

¹ Personal Correspondence, 1991, Kenneth P. Allen, Bergman Associates, Rochester, NY.

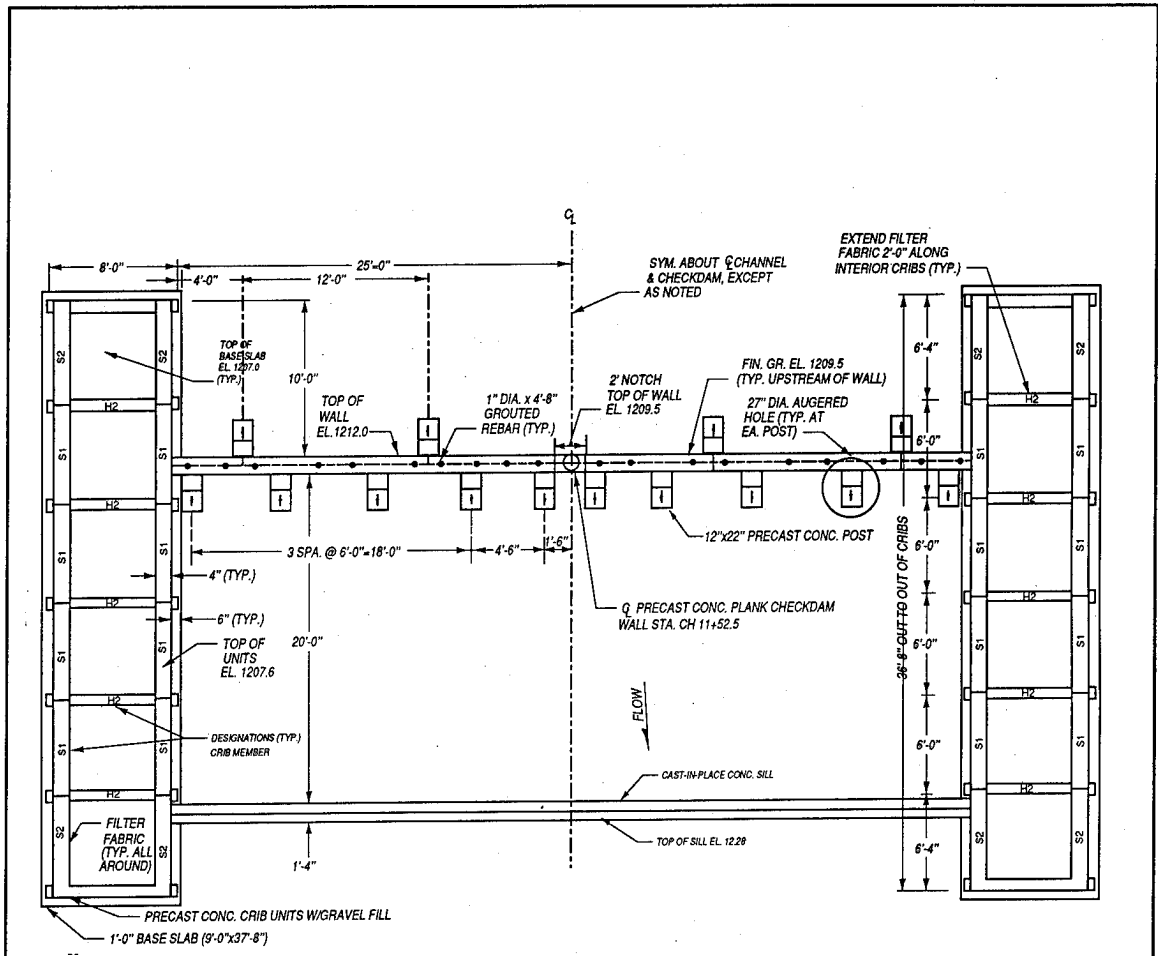

a. Plan

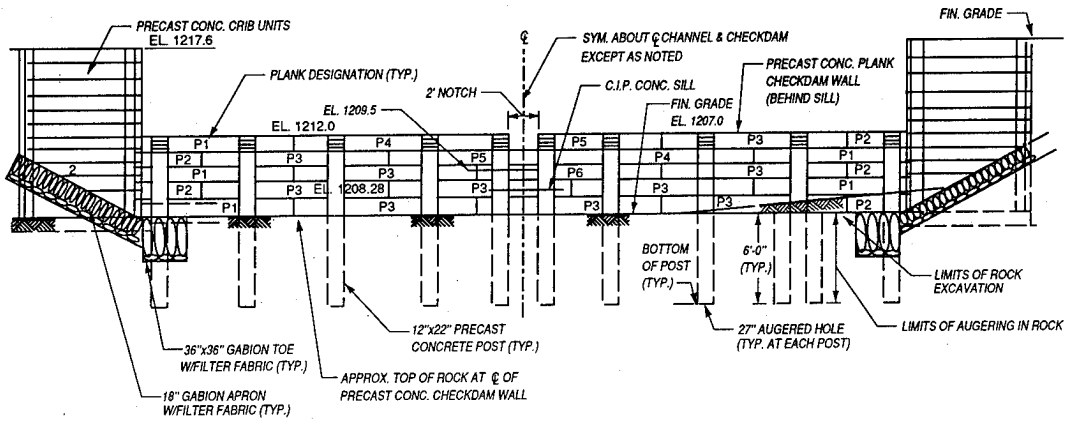

b. Elevation looking upstream

Figure 67. Structural plan and elevation, Chauncey Run Checkdam No. 2 (after Allen 1991)

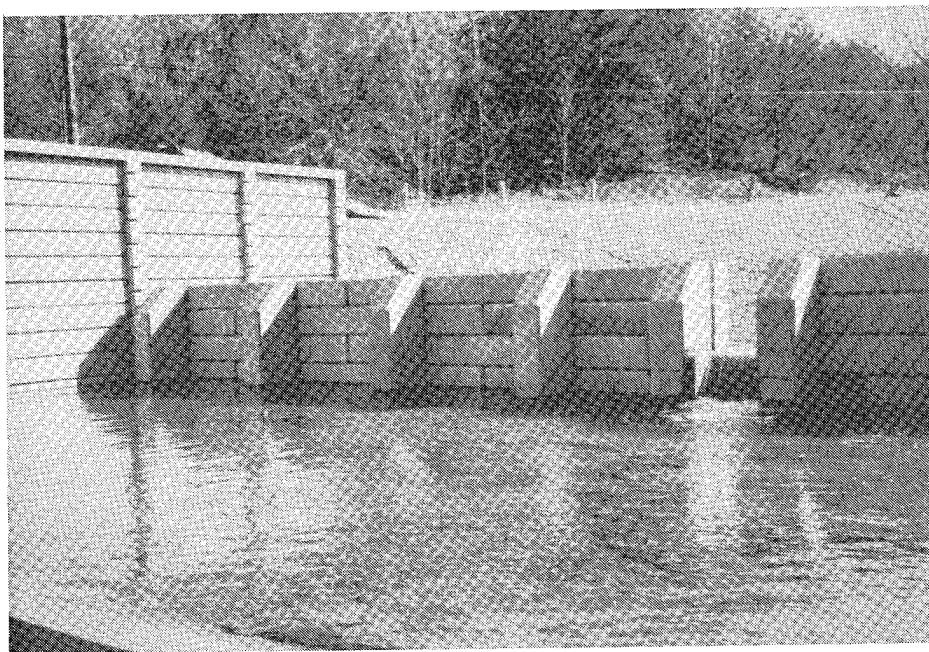
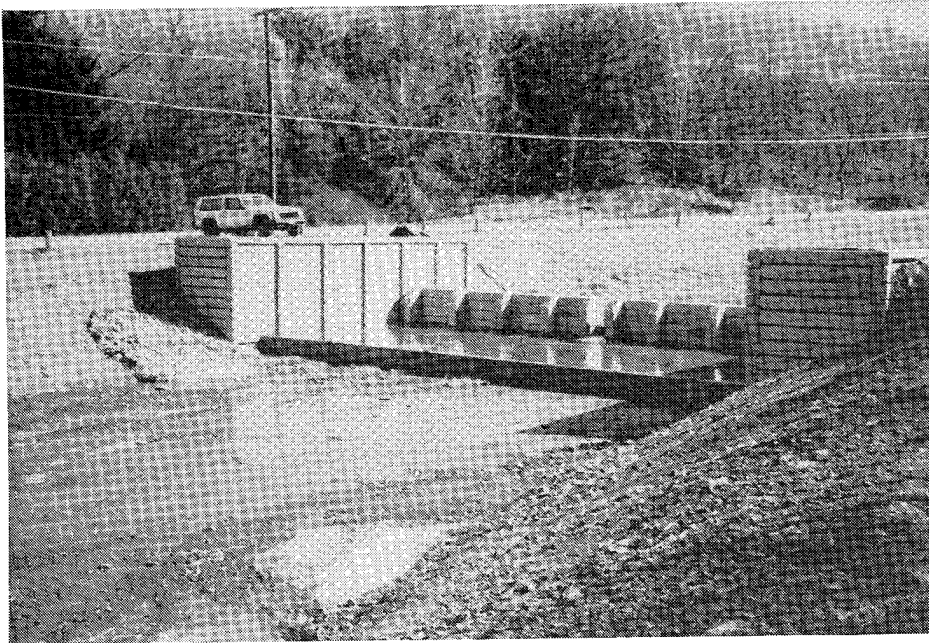

Figure 68. Precast concrete checkdams, Chauncey Run, NY (from Allen 1991)

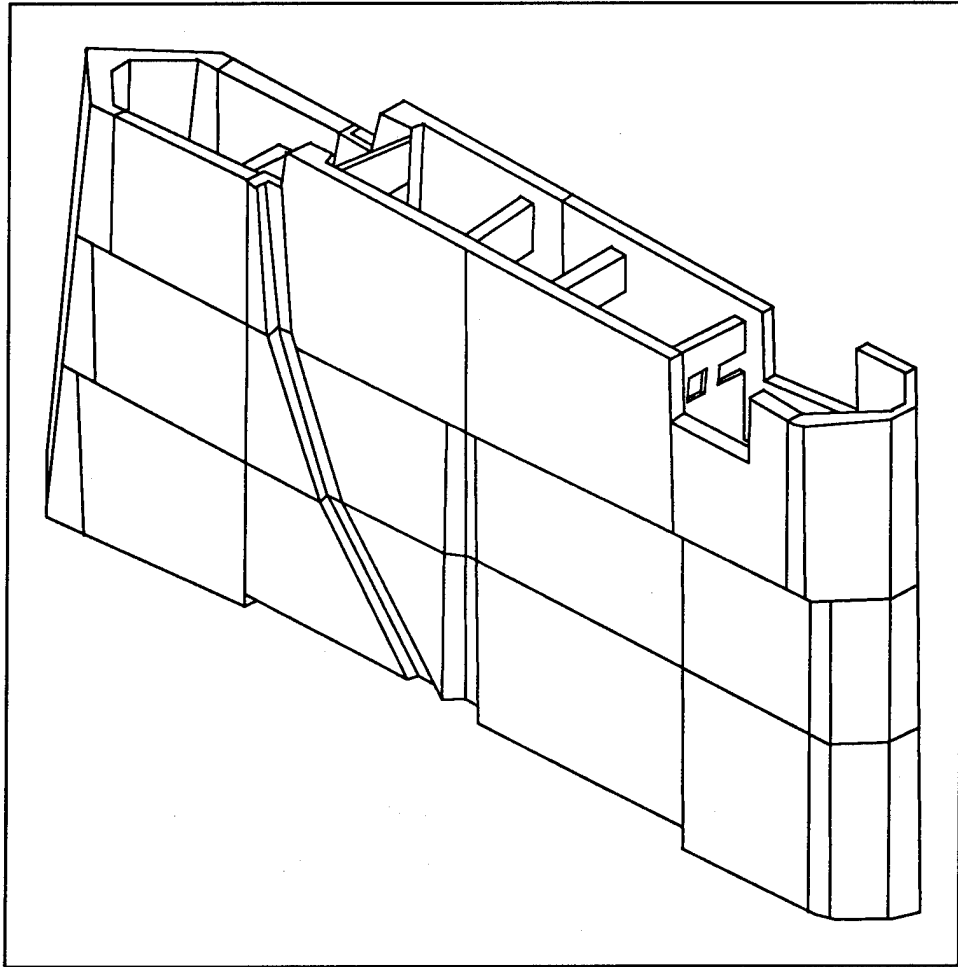

Figure 69. Isometric view of gate pier 6, C-1 Dam

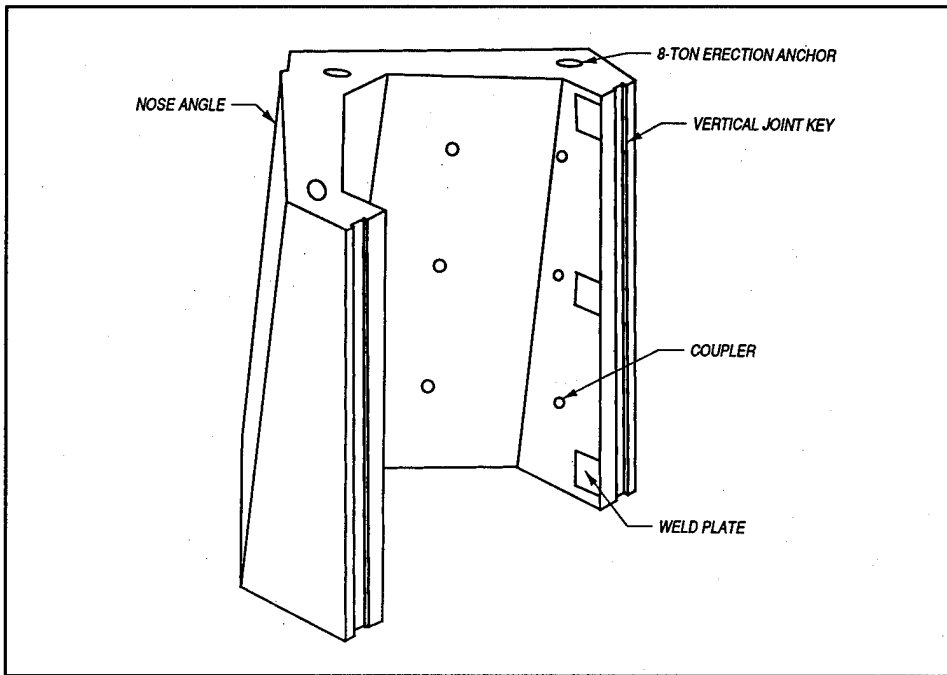

Figure 70. Precast nose unit, C-1 Dam

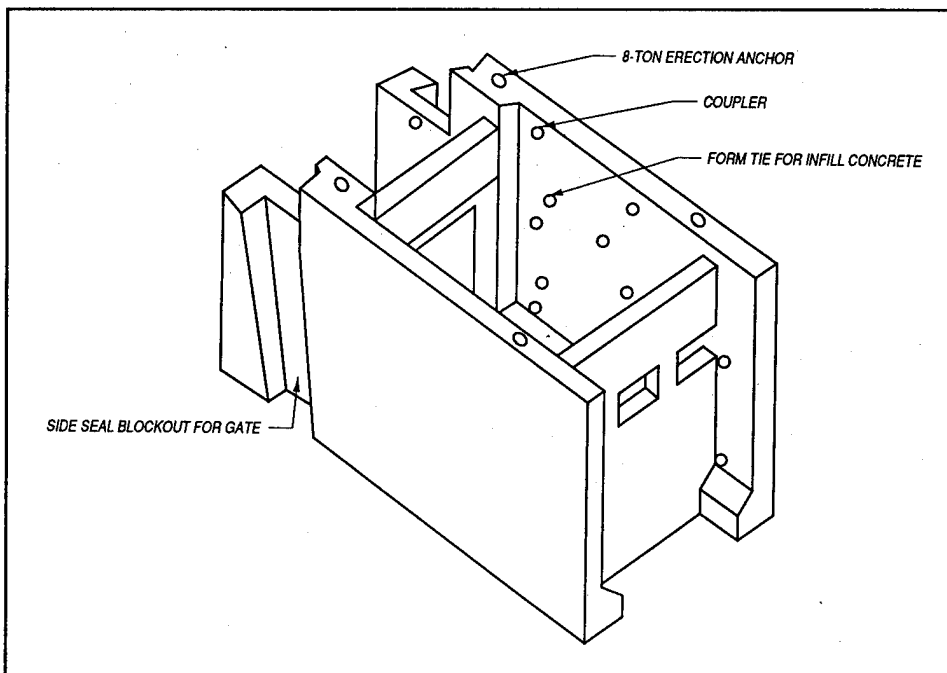

Figure 71. Typical precast pier unit, C-1 Dam

were 1/2 in. (plus or minus) or 1/8 in. per 10 ft of length, whichever is greater. Panel thickness and unit width tolerances were 1/4 in.

The precast pier units were transported via tractor-trailer rigs to a launch ramp near the dam. At this point, the loaded rigs were driven on to a barge for transportation to the construction site in the river. The pier units were offloaded with a crane located on the cofferdam. A second crane inside the cofferdam was used to position the pier units. After each tier of units was properly positioned and aligned, the vertical and horizontal joints were grouted, reinforcement was installed inside the units, and the units were filled with conventional concrete (Figures 72 through 74).

Eighteen precast units were used in each gate pier. The completed piers are 8 ft wide, 61 ft 6 in. long, and 28 ft 6 in. high. Following completion of the gate piers, the tainter gates were reinstalled (Figure 75). A similar procedure was then used to rehabilitate the four remaining gate piers.

Central and South Florida Flood Control Project

The overall project includes six structures (S-65 through S-65E) located on the Kissimee River. Each structure consists of a navigation lock and spillway. The structures are reinforced concrete with low ogee-type spillways and vertical lift gates. The widths of the structures are 87.5 ft for the 3-bay spillways (S-65, S-65A, and S-65B), 119.0 ft for the 4-bay spillways (S-65C and S-65D), and 179.5 ft for the 6-bay spillway (S-65E). The S-65E spillway was the only structure built with baffle blocks in the stilling basin. Construction of the spillway was completed in 1967.

A heavy rainfall event in October 1969 caused severe flooding of the lower Kissimee River basin. The riprap channel sections downstream of all spillways except S-65E received substantial damage. The channels were repaired and then maintained periodically; however, riprap movement continued to be a problem.

Hydraulic model tests were initiated in 1975 to determine whether the cause of the problem was an inadequate basin or faulty riprap design. Test results showed that stilling basins without baffle blocks did not provide satisfactory energy dissipation. Two methods to reduce the scouring action were evaluated: placing baffle blocks in the stilling basin and replacing the existing 18-in. riprap with larger sizes of stone. After tests were conducted to determine the optimum size and configuration of the baffle blocks and the size and extent of riprap (Turner and Pickering 1979), an economic analysis by the Jacksonville District showed that the baffle blocks would be the less costly alternative.

Before the baffles were placed, soil anchors were installed in the aprons to counteract the increased lateral and overturning forces distributed from the baffle blocks and to prevent any possible apron slab movement. Dewatering was not required for complete installation of the soil anchors. The anchor

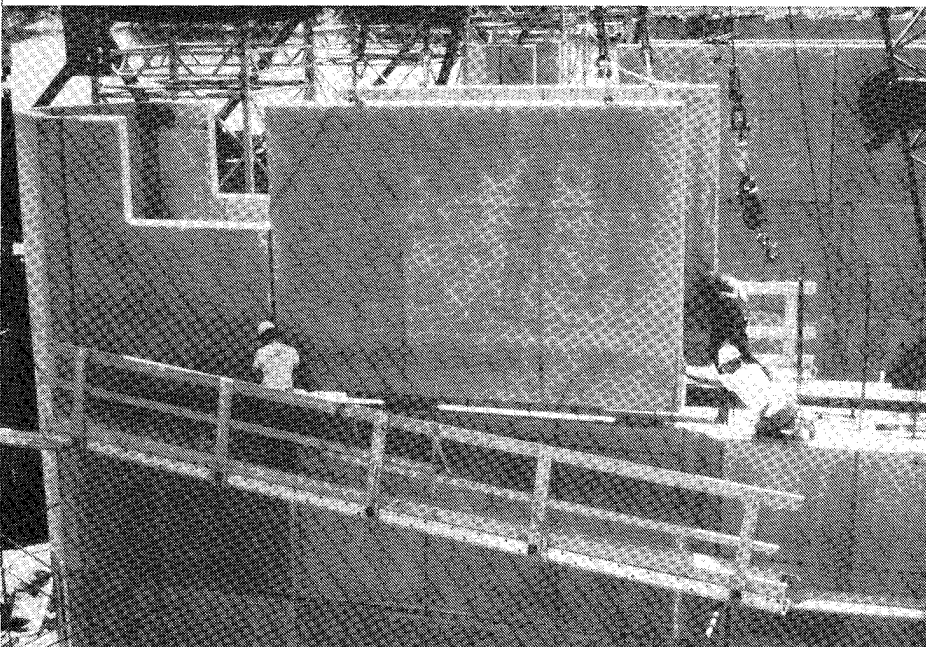
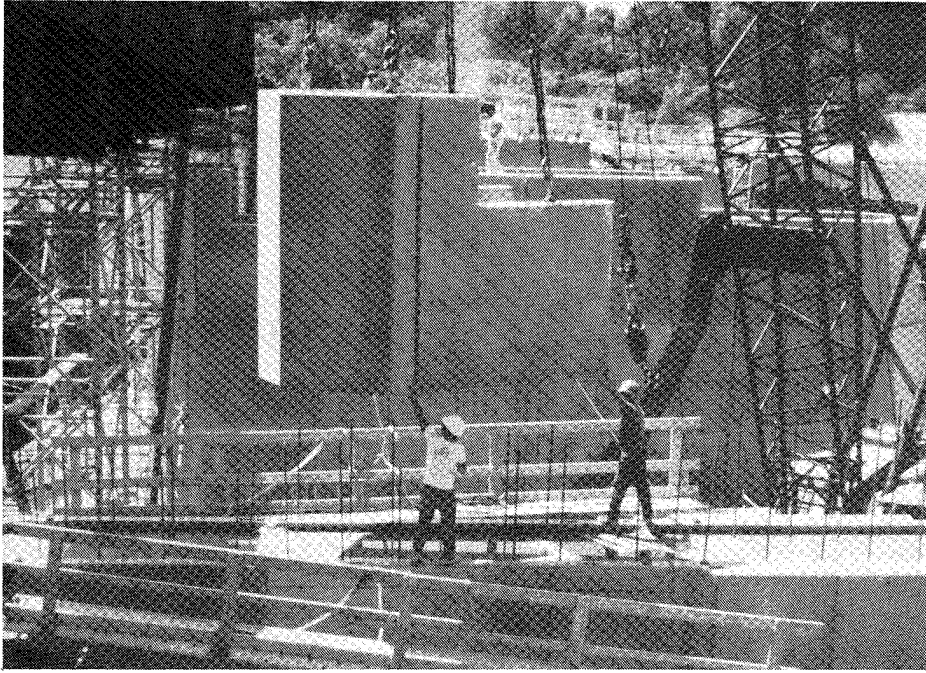

Figure 72. Positioning precast gate pier units, C-1 Dam

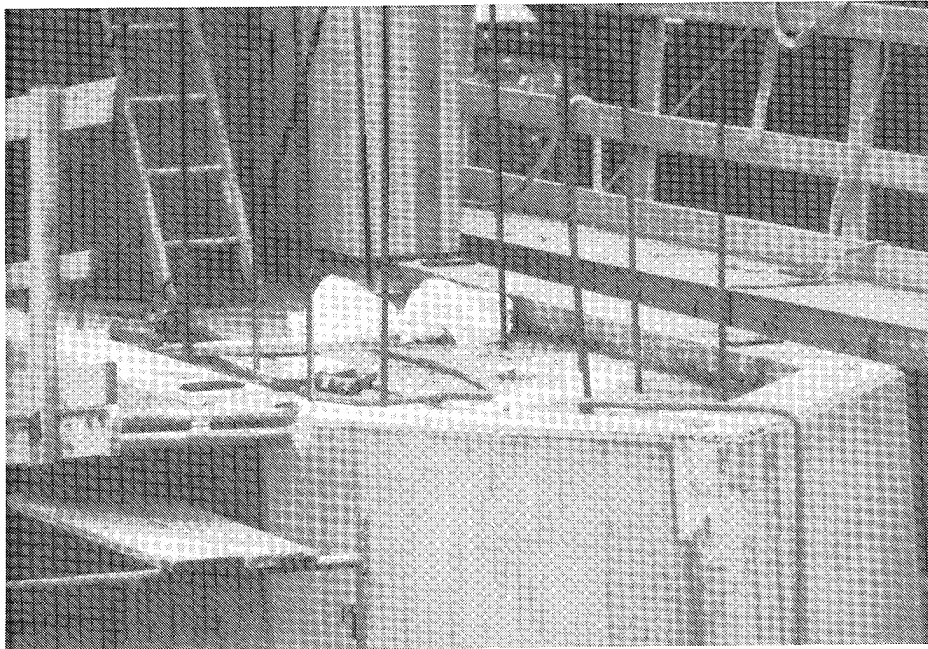
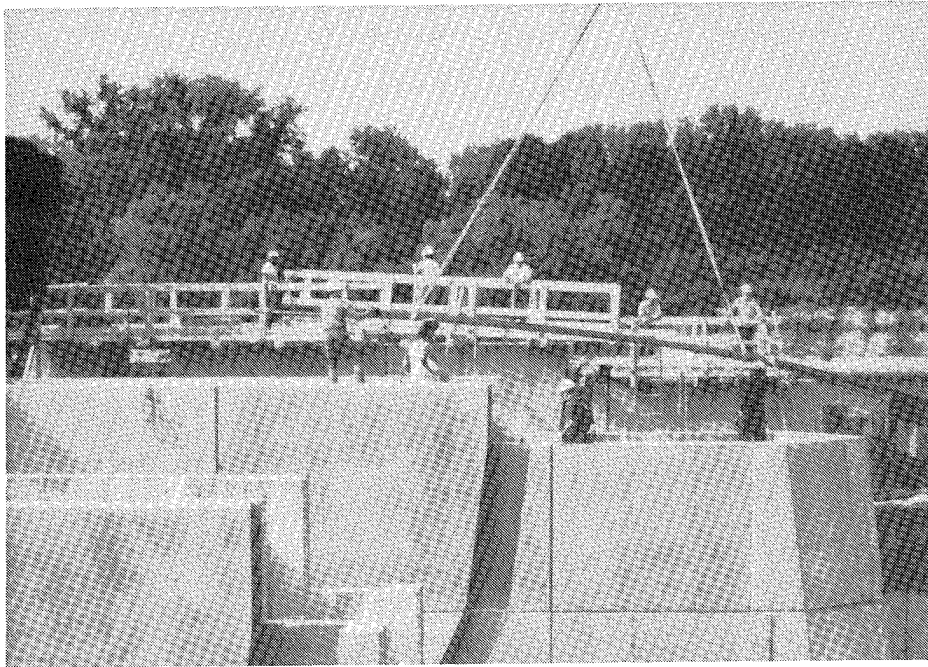

Figure 73. Reinforcing for infill concrete, C-1 Dam

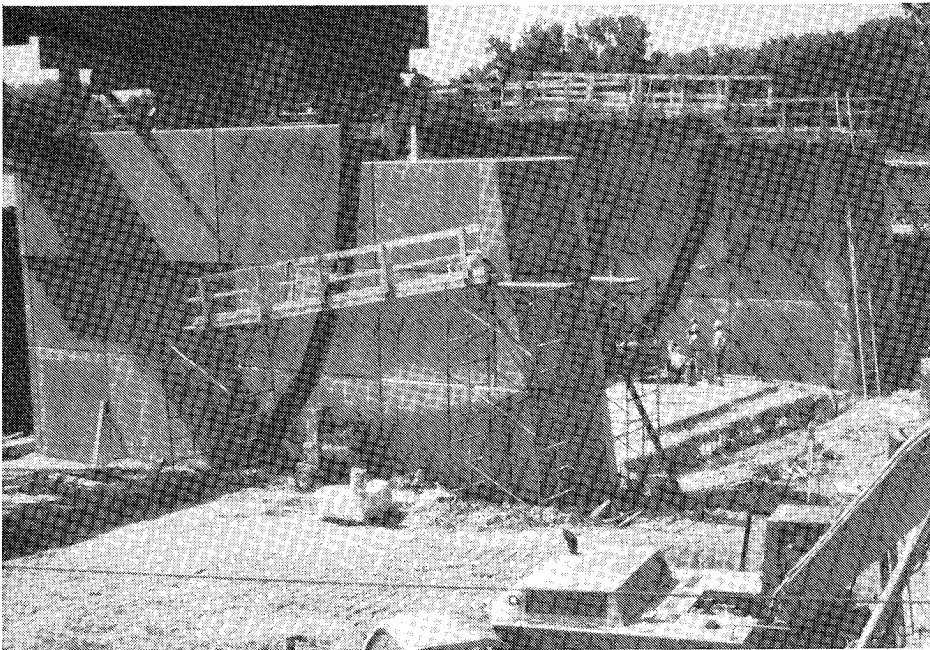
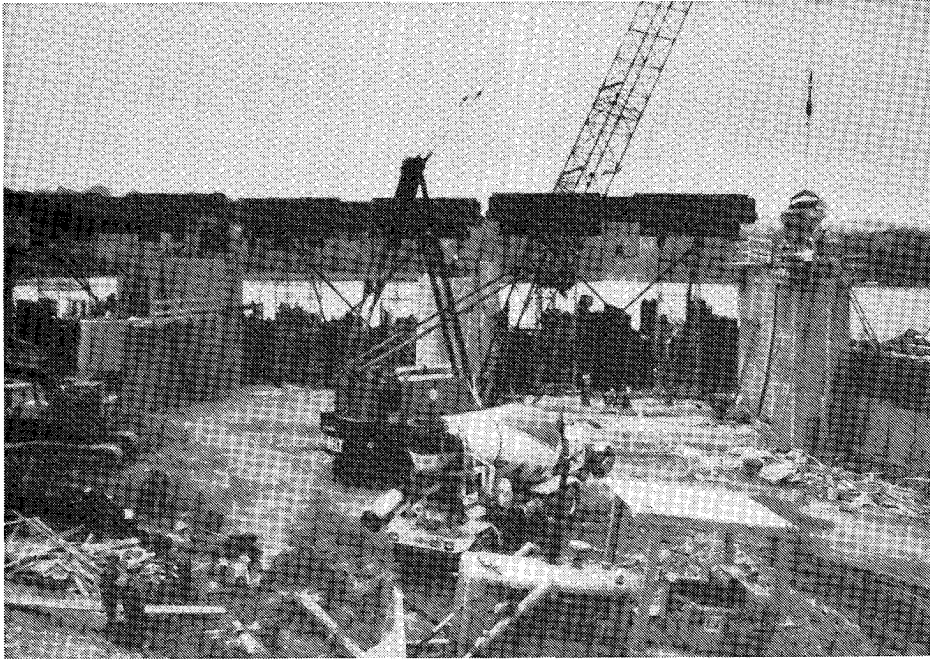

Figure 74. Precast concrete gate piers, C-1 Dam

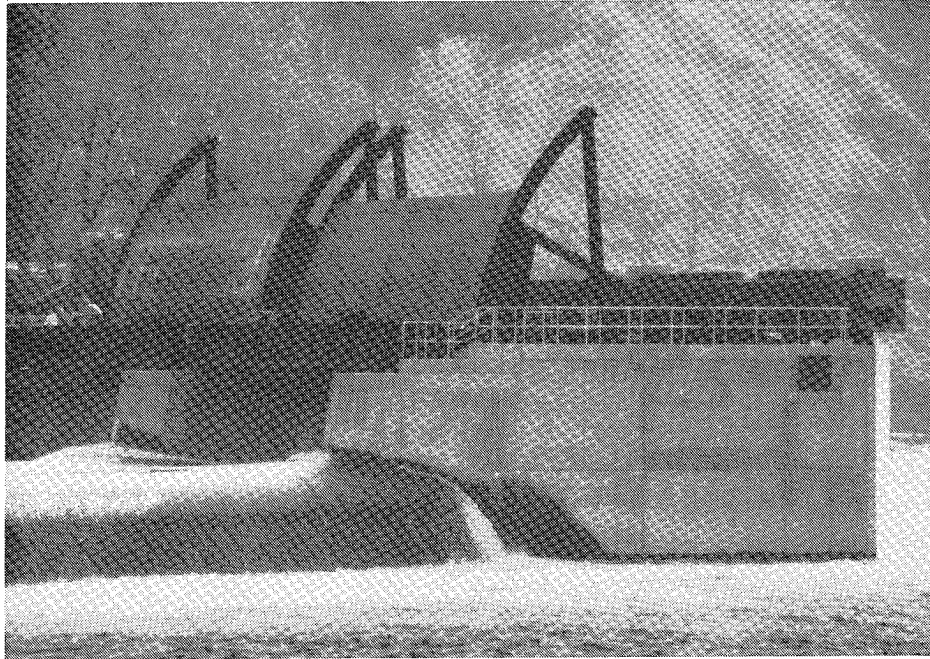

Figure 75. Completed gate piers with gates installed, C-1 Dam

bars were placed and grouted in a casing. Water was maintained above the holes bored through the stilling basin slab to keep the differential head to a minimum. This potential force could have caused extensive damage to the soil bearing the apron slab by forcing it up through the holes. The final operation of grouting the recess in the existing concrete apron was accomplished in the dry.

The precast concrete baffle blocks were designed (Figure 76) to withstand the highest velocity forces that could occur during the design flow rate. Number 10 dowels used to anchor the dowels of this size provided a large perimeter for bond to withstand the shear and tensile stresses. Epoxy grout was used to embed the dowels in holes drilled into the existing slab and to fill the preformed dowel holes in the baffles. Epoxy was also used to bond the baffles to the stilling basin slab. All work related to the installation of the baffle blocks was accomplished in the dry. The contractor was limited to dewatering only two adjacent baffle blocks at one time in order to prevent excessive uplift which could have jeopardized the stability of the existing concrete apron.

Bedding and riprap repairs were made without dewatering. The material was placed with a mobile crane, and repairs were performed during periods of restricted discharges to prevent segregation and movement of the bedding stone.

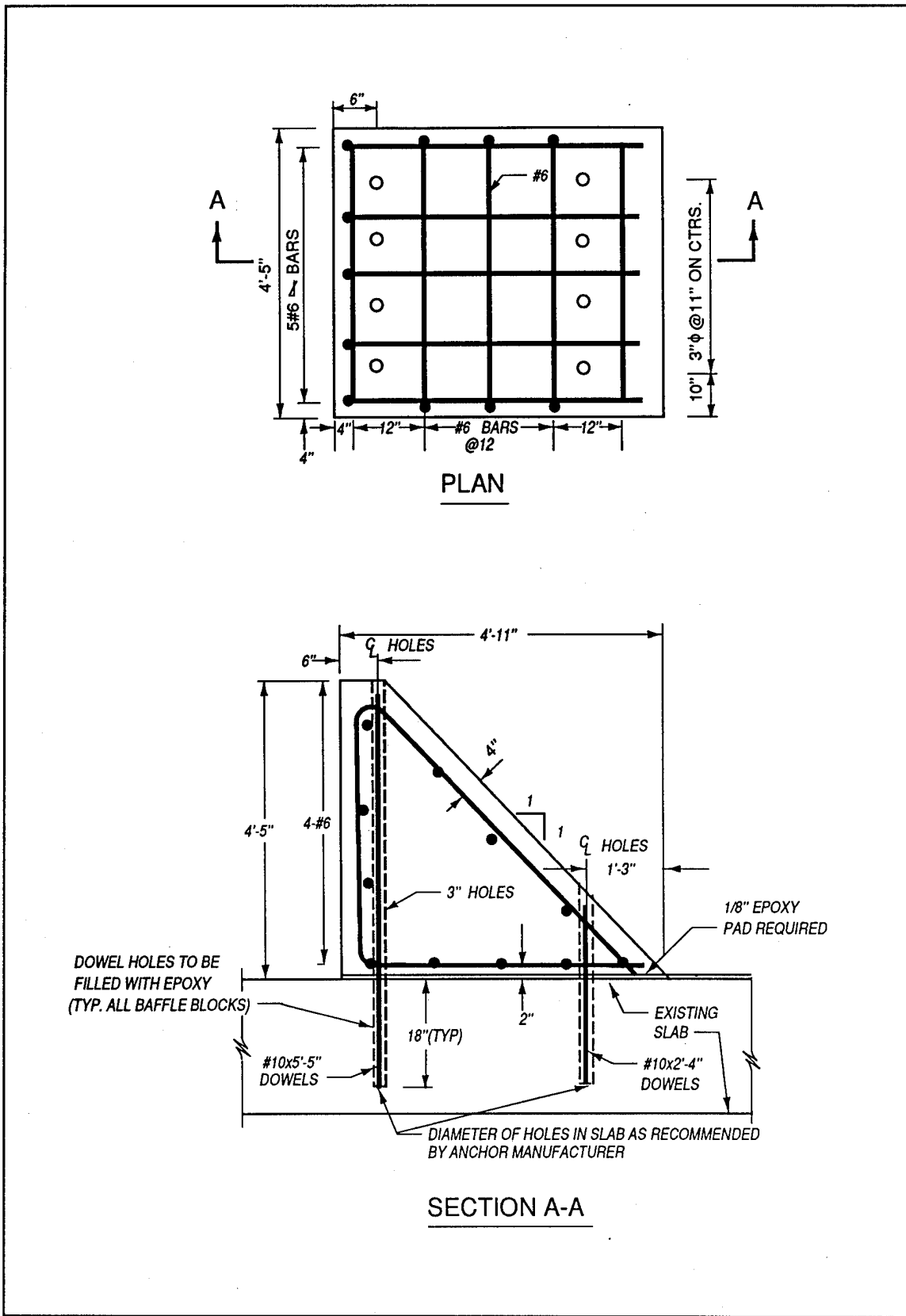

Figure 76. Design details for precast concrete baffle blocks, S-65 and S-65A structures, Central and South Florida Flood Control Project

The following is a breakdown of the final project cost (1989 dollars):

Sodding	\$ 18,700.00
Bond	11,000.00
Removal of existing material	59,264.00
Bedding stone	256,263.15
Riprap stone	367,763.40
Dewatering	381,450.00
Baffle blocks	273,800.00
Performance-tested soil anchors	139,000.00
Proof-tested soil anchors	402,000.00
Concrete grout for riprap	32,412.50
Modifications	217,433.00

Total	\$2,159,086.05

The contract for the repairs was awarded in September 1984. Construction was completed in December 1985.

Fellows Lake Dam

Fellows Lake Dam, completed in 1955, is located approximately 4-1/2 miles northeast of Springfield, MO. The earthen dam is 100 ft high and 2,100 ft long and transitions into a 700-ft-long concrete spillway that drains into a 100-ft-wide by 1,600-ft-long concrete chute (Figure 77). The 750-acre reservoir, which holds approximately 9 billion gallons of water, is Springfield's largest source of drinking water.

Springfield's growth rate in the last decade created concern as to whether the city's drinking water supply would be adequate for future needs. After studying alternatives for additional sources of drinking water, the local municipal water utility opted to pipe water 32 miles from a Corps of Engineers reservoir used for hydropower generation. Since implementation of this project would take several years, a decision was made to create an interim water supply by raising the crest of the spillway at Fellows Lake (Rogers and Ruggeri 1992).

The effect of raising spillway crest on the hydraulic characteristics of the dam was analyzed. Spillway height increases of 2, 4, and 6 ft were considered. It was determined that with a 4-ft increase in height, the spillway could still pass the flood produced by the required 75-percent probable maximum precipitation without increasing the height of the dam.

Several alternatives for raising the spillway were examined, including a rubber, inflatable dam and different types of mechanical gates. A cast-in-place concrete wall was not feasible because of inadequate anchorage in the spillway apron. The method selected for raising the height of the spillway was precast concrete gravity units.

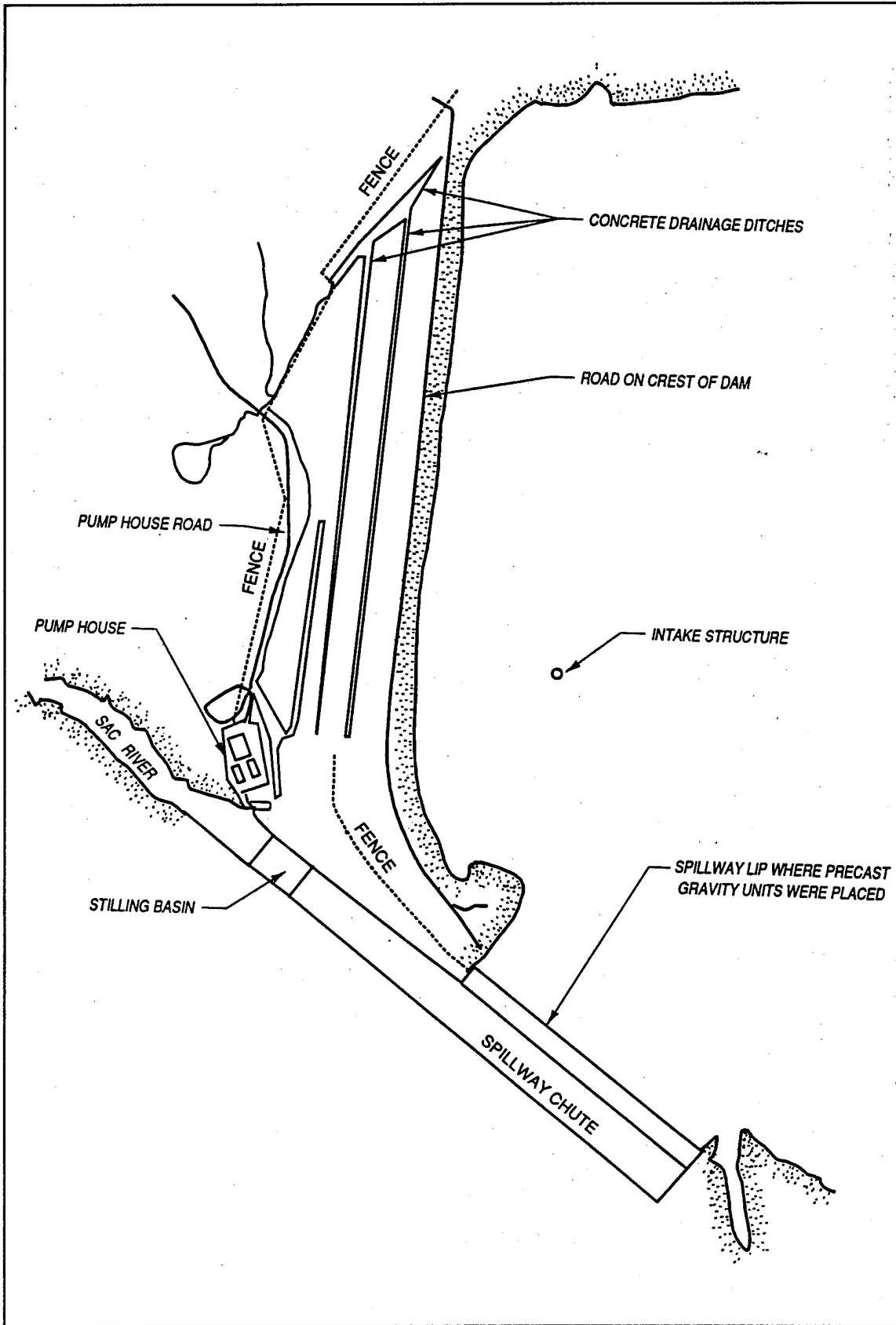

Figure 77. Layout of Fellows Lake and Dam (after Rogers and Ruggeri 1992)

Factors considered in the design of the units included the shape of the spillway weight required to resist hydrostatic forces, anchoring, and handling. Each reinforced concrete unit (Figure 78) is 2 ft wide and weighs approximately 7,000 lb. The weight of each block is sufficient to resist hydrostatic overturning forces with a 1.95 factor of safety. Steel plates and angles to be used for anchoring were included in the bases of the gravity units during precasting. A 4-in.-diam PVC pipe section was placed horizontally through each unit just above the center of gravity; when a unit needed to be moved, a steel bar was inserted through the pipe, and the ends were lifted with a forklift or hoist. A "key," or vertical indentation formed into the sides of the units, allowed the steel pipes to be removed after the units had been placed with sides touching.

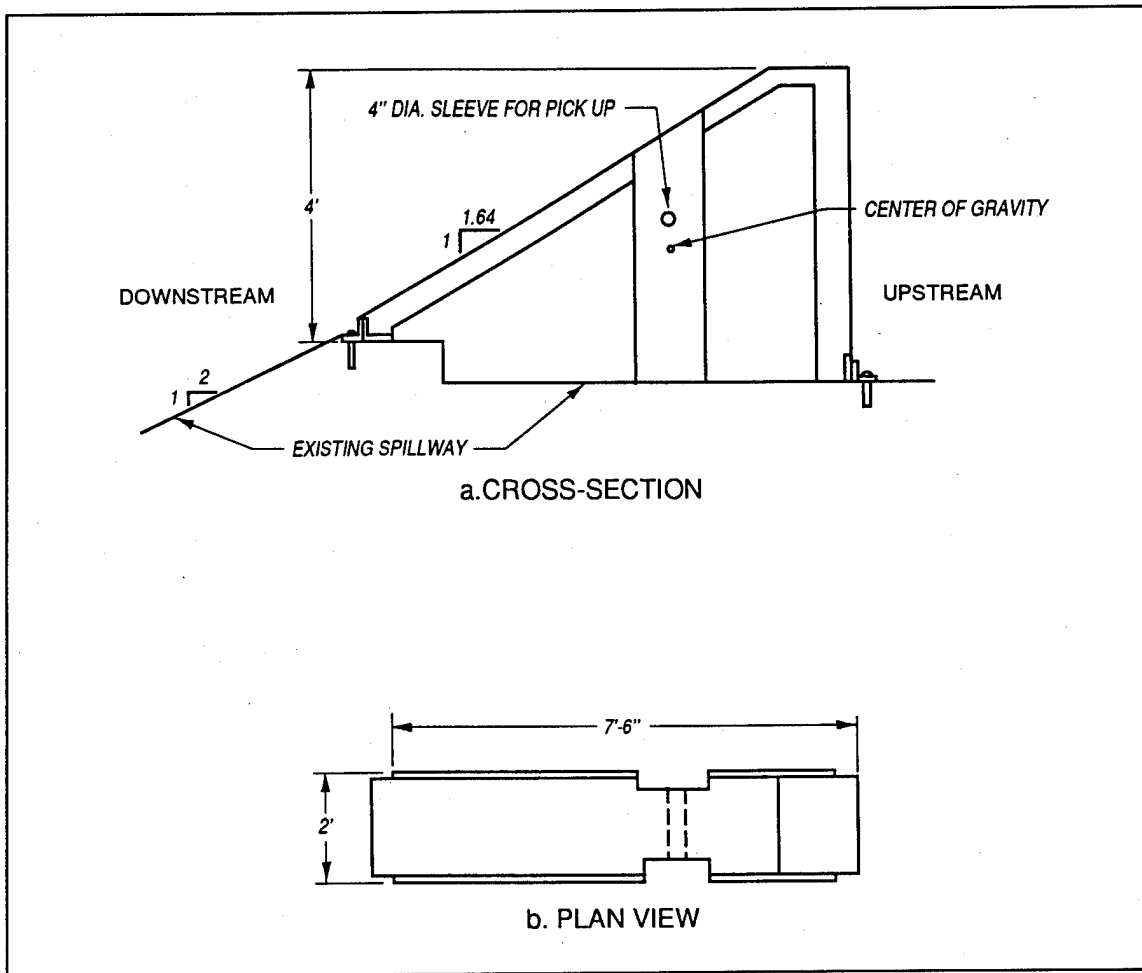

Figure 78. Precast concrete unit installed at Fellows Lake and Dam (after Rogers and Ruggeri 1992)

To maintain dimensional specifications for all units, the precast fabricator designed special steel forms that could withstand the necessary reuse. The units were cast upside down to make it easier to place the reinforcing steel cages and to achieve uniformity in concrete placement within the sloped sides

of the forms. The steel angles and plates were spot welded to the reinforcement and bolted to the form before the concrete was placed.

Prior to placing the precast units, all areas of deteriorated concrete and exposed reinforcing in the existing concrete were removed and repaired. Perforated PVC drains were installed in the gravel backfill of the repair area to provide drainage during concrete placement and afterwards to control underflow. Once the gravity units were in place, they were bolted to the existing concrete along the bottom and welded to the steel plates and angles along the top. A waterstop placed under and behind these angles minimized leakage. The joints and keys between units were filled with grout.

Raising the spillway has provided Springfield with an additional billion gallons of water supply storage. The project was begun October 1991 and completed March 1992, 2 months ahead of schedule. Total time actually spent in placing the 350 precast units was about 22 days. The innovative precast concrete blocks proved to be an economical, efficient, and relatively easy method to raise the spillway crest. The total construction cost was approximately \$400,000.

Olmsted Dam

Olmsted Dam will be constructed by the Louisville District near the lower end of the Ohio River. The navigable pass portion of the dam will be a 2,200-ft-long pile-supported weir which will incorporate 220 hydraulically operated wicket gates. Traditionally, such a dam would be constructed inside fixed cellular-sheet-pile cofferdams; however, the District retained Ben C. Gerwick, Inc., to develop and evaluate alternate construction methods. Two alternatives were developed: a mobile steel cofferdam with a 200-ft-long by 76-ft-wide construction area and underwater construction of the dam sill and stilling basin with precast concrete (Berner and Ghio 1994). The criteria for evaluating the alternate methods included feasibility, safety, impact on barge traffic, impact on the environment, and potential time/monetary savings.

The dam would be constructed in 200-ft increments with the mobile cofferdam. With this method, the steel vessel would be floated into a predredged trench over the top of previously driven piles, set down, using rubber seals to join to the previous dam segment and tremie concrete to seal to the trench bottom and piles; the construction well would be dewatered and the dam sill built with precast concrete elements up to 200 tons each and cast-in-place concrete; the well would be flooded; and the cofferdam would be floated and pulled forward.

Purchase or lease of an approximately 3,000-ton capacity crane barge would be required for lifting and installation of the precast concrete shells for the dam sill, which would weigh 2,600 tons each (Figure 79). A trench would be predredged in the river and piles driven in a manner similar to that used for the cofferdam; however, this method would not require dewatering. The precast shell segments would be installed and connected underwater in a

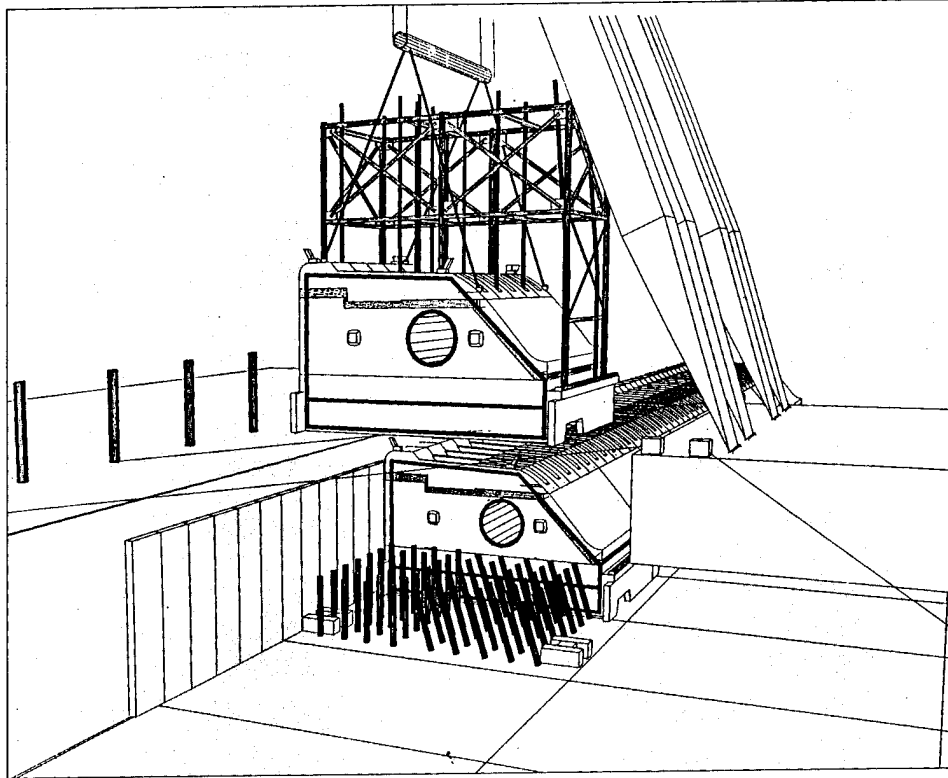

Figure 79. Concept for underwater installation of precast sill shells, Olmsted Dam (from Berner and Ghio 1994)

manner similar to that used for immersed tunnel tubes. Rubber seals and steel bellows would be provided at both ends of the preformed gallery. Once in position, the precast concrete elements would be infilled and tied-in with the foundation with tremie concrete. The stilling basin would be constructed underwater with precast concrete panels and tremie concrete in both cases.

Both alternate construction methods offer advantages over the fixed cofferdam method, including (a) earlier initiation and completion of the project, (b) significant cost savings, (c) reduced environmental impact, (d) superior abrasion-resistant concrete surfaces as a result of precasting, and (e) demonstration of an innovative construction technique that can be used on subsequent projects. Although both alternatives were found to be feasible, the large precast concrete shells were finally recommended for reasons of safety and greater reuse value of the specialty equipment, such as the crane barge.

Deadwood Dam

Deadwood Dam, a feature of the Bureau of Reclamation's Boise Project, is located on the Deadwood River approximately 90 miles by road northeast of Boise, ID, and approximately 65 miles southeast of Cascade, ID.

The dam is a concrete arch-type structure with a structural height of 165 ft and a hydraulic height of 137 ft. The dam crest length is 749 ft at elevation 5,340 ft, and the crest width is 9 ft. The dam contains 55,463 cu yd of concrete. Construction was completed in 1931 by Utah Construction Company of Ogden, UT, at a total cost of about \$1,400,000 (Newell 1931).

Deadwood Reservoir, located in semiwilderness surroundings (annual snowfall in this area can exceed 40 ft), contains a total storage capacity of 161,900 acre-ft and has a surface area of 3,000 acres. This water is used to provide regulated flow for Reclamation's powerplant at Black Canyon Dam on the Payette River near Emmett, ID, and to enhance irrigation and recreation flows.

Over 50 years service in the harsh Idaho climate resulted in freezing and thawing deterioration, cracking, carbonation, and weathering over much of the dam's surfaces. What was believed to be seepage through vertical joints and lift lines contributed to the freezing and thawing deterioration on the downstream face. Joint sealant on the parapet walls and walkway of the crest had weathered away, allowing snow melt and rainwater to contribute to damage of the joints and to the parapet walls. The surface of the crest walkway showed early stages of freezing and thawing deterioration, cracking, and spalling.

In 1980, the Boise Regional Office requested that Reclamation's Denver Research Laboratories design and conduct a series of trial field repairs at Deadwood Dam. The results of these trials were used to prepare construction specifications for rehabilitation of the dam. Personnel from the Boise Regional Office, the Snake River Projects Office, and the Denver Engineering and Research Center participated in the field program.

The trial repair program consisted of five parts, one of which was the installation of precast polymer concrete caps on the tops of the deteriorated parapet walls. Fifteen 5-ft-long channel sections of precast vinylester concrete (Figure 80) were installed on the upstream parapet wall near the right abutment. This wall was suffering from severe freezing and thawing deterioration, primarily at the top of the wall. The deteriorated wall concrete was removed with chipping hammers and grinders. The polymer concrete segments were positioned over the wall, sealed, and bonded to the wall with silicone caulking and epoxy bonding agent (Figure 81). It was then planned to pump cementitious grout into the voids between the segments and the wall. During installation, however, the grout pump failed and the voids were left empty. The vinylester concrete mixture was a proprietary formulation. The 1984 cost of these segments was \$16.00 per lin ft.

To date, the parapet wall segments are showing very minor weathering and freezing and thawing deterioration of the paste on the top horizontal surfaces. This deterioration has exposed only the sand phase of the aggregate system and is not yet considered very serious. Some cracking is also evident at the joints between the precast segments, as can be seen in Figure 82. It is believed that leaking joints between the segments allow moisture to get between the caps and the concrete, where it subsequently freezes, expands, and causes

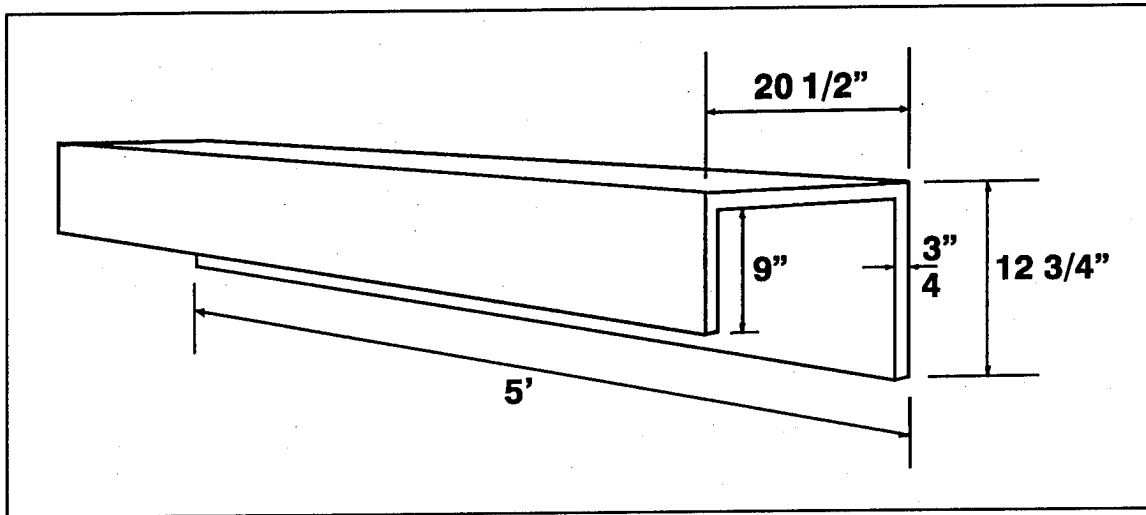

Figure 80. Polymer concrete channel cladding; Deadwood Dam

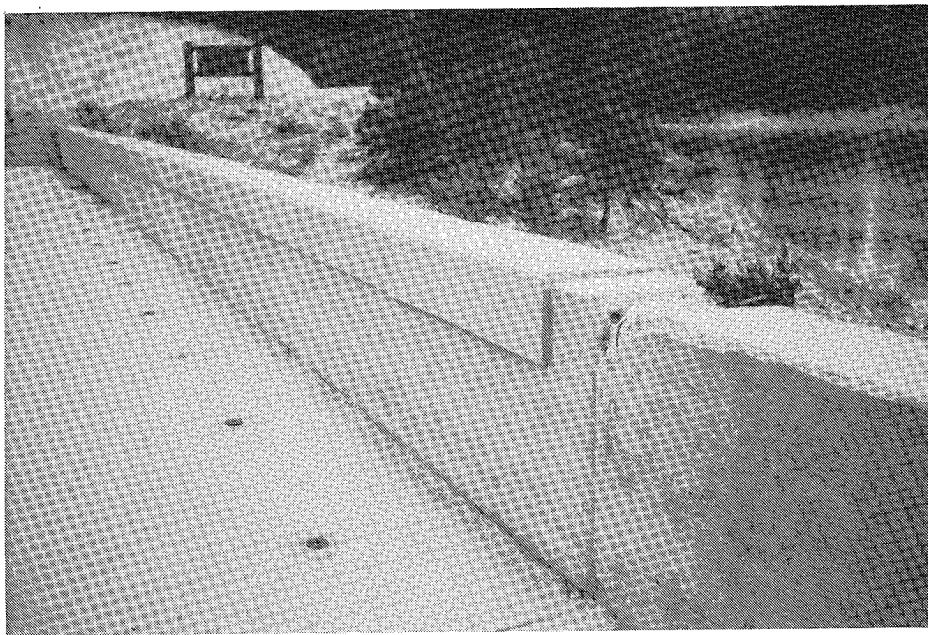

Figure 81. Parapet wall caps, Deadwood Dam

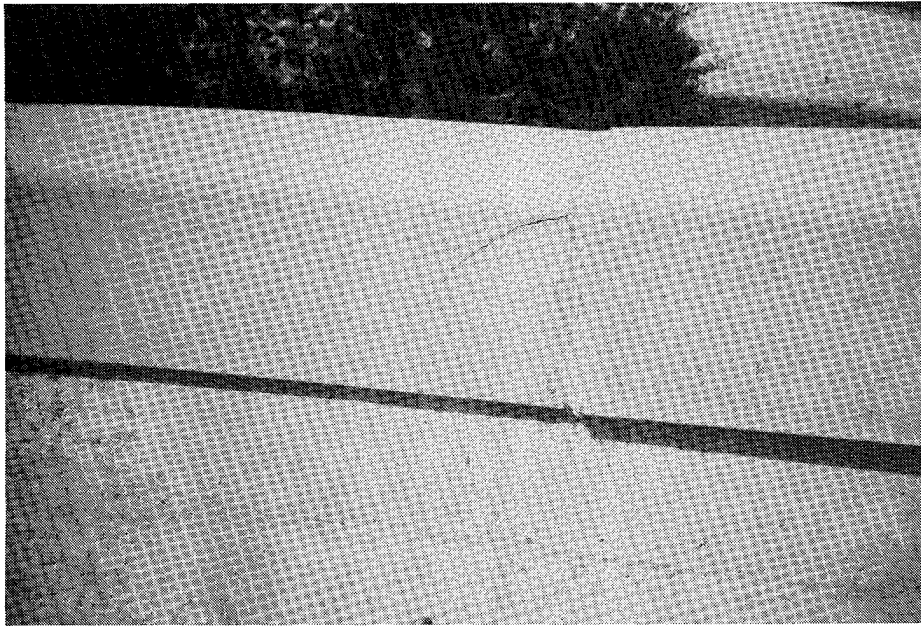

Figure 82. Cracks at joints in parapet wall caps, Deadwood Dam

the cracks. Several of the segments also contain cracks that occurred during initial installation as a result of inconsistent wall dimensions.

Channels, Floodwalls, and Levees

Innovative applications of precast concrete in channel, floodwall, and levee improvement projects include linings and overlays for channel walls, retaining walls for channels, partial and complete channel elements, articulated mats for erosion control, a folding floodwall, caps for floodwalls, sill beams for gated levee/floodwall closure structures, and gatewalls for levees.

Placer Creek Channel

Placer Creek flows through the town of Wallace, ID. After a fire in 1910 destroyed much of the forest surrounding the creek, periodic heavy rains caused flooding and sediment movement in Wallace. The city built a flood-control channel to combat the problem. For several decades, the channel was repaired and rehabilitated until the channel linings became badly deteriorated and large volumes of debris collected in the channel, reducing its capacity and damaging the walls and adjacent property.

Congress authorized a channel rehabilitation project in 1970. The Hydraulic Laboratory, North Pacific Division, used hydraulic model tests to verify the design. Construction began in July 1981. The rehabilitation, described in detail by Hacker (1986), is summarized here.

The contractor chose to use cast-in-place concrete for the channel bottom and precast panels for the walls (Figure 83). By using precast panels, the contractor was able to reduce:

- a. Rehabilitation time.
- b. Excavation requirements.
- c. Cost of the forming system.
- d. Congestion at the project site.
- e. Size of the work force.

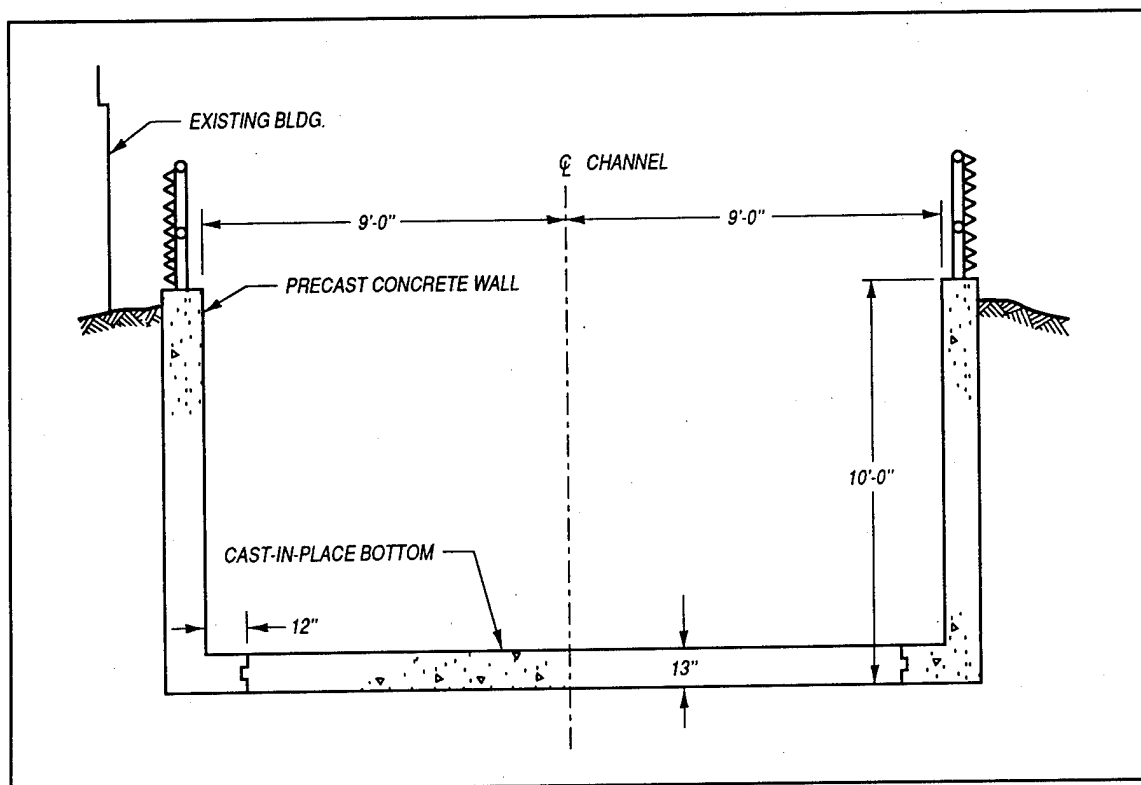

Figure 83. Typical channel repair section, Placer Creek (after Hacker 1986)

During rehabilitation, Placer Creek was diverted from the channel with a bypass pipe placed on the streambank. In addition, a 600-ft basin with a debris barrier was constructed upstream. The effectiveness of the basin was proved in February 1982 when a flood of approximately 10-year frequency occurred. The basin trapped approximately 3,000 cu yd of debris, preventing damage to the channel and surrounding area.

Concrete was supplied by a local ready-mix plant. Aggregates used in the mixture were limited to 1-1/2 in. and were approved by the Government. Specifications called for a compressive strength of 3,000 psi at 28 days and

5.5 ± 1 percent air entrainment. The maximum allowable water-cement ratio was 0.45.

Approximately 600 reinforced-concrete panels were precast in a local casting yard. Each panel was approximately 15 ft long and 10 ft high. A 12-in. stub at the bottom of each panel provided continuity of the reinforcing through the corner joint.

Where possible, existing walls were used for shoring. Walls that could not be used were removed. Foundation material behind the walls was excavated to a 0.5H-on-1V cut, allowing for drainage at all times.

Once a panel was placed, it was secured with adjustable bracing from within the channel. This procedure made it possible to control alignment and vertical spacing between joints. A preformed neoprene compression seal was used to seal joints. The compression seal was installed with a polyurethane lubricant adhesive. Reinforcing steel in the floor was spliced to the reinforcing which extended from the precast wall panels. Cast-in-place concrete was used for the floor slabs.

Bracing was kept in place until the concrete in the floor slabs had reached a minimum compressive strength of 1,500 psi. Random backfill was then placed behind the walls in horizontal layers and compacted.

All concrete construction was completed by December 1982, and the rehabilitated channel was dedicated 15 July 1983.

Approximately 7,000 cu yd of portland-cement concrete was used in the 3,700-ft-long channel. Estimated cost for the project was \$3,870,000, Federal, and \$350,000 for the City of Wallace and Shosone. The construction contract was for \$3,770,465, Federal, and \$300,000, non-Federal. Contract modifications amounted to \$323,000. The use of precast panels saved approximately \$185,557.

Blue River Channel

A 12-mile-long stretch of the Blue River flows through Kansas City on its way to emptying into the Missouri River. Periodically, the river has flooded the residential and industrial areas in this stretch. The Blue River Channel Project, authorized by Congress under the Flood Control Act of 1970, was designed to provide flood protection to the Blue River Basin.

The project consists of construction of several flood-control structures. Near the upstream end of the project, a concrete grade control structure will dissipate the river's energy. The 118-ft-wide by 169-ft-long basin was designed to pass a 500-year flood of 35,000 cfs. A paved reach, approximately 3,500-ft-long, provides hydraulic efficiency through an industrial area. Structures in the paved reach include the paved channel, a 5.5-ft-deep by 15-ft-wide low-flow channel, a concrete slope stability structure, an L-shaped

concrete-slab bridge for trucks and railcar traffic, and an approximately 1,700-ft-long concrete flood wall to control 30-year flood flows (Ganaden 1991).

The original design for the low-flow channel consisted of a pair of steel sheet-pile walls with a cast-in-place concrete strut between the walls. However, there was some concern about this method of construction because the soil in the existing channel is embedded with a 40-year accumulation of steel smelting slag and other debris. The chunks of slag range in size from small as a baseball to huge as an automobile. Driving sheet piles through this material could be very expensive or even impossible. Therefore, it was decided to prepare an alternate design for a precast-concrete U-flume (Figure 84) in order to save time in the preparation of a modification if the sheet-pile flume was not constructible (Mitscher 1991).

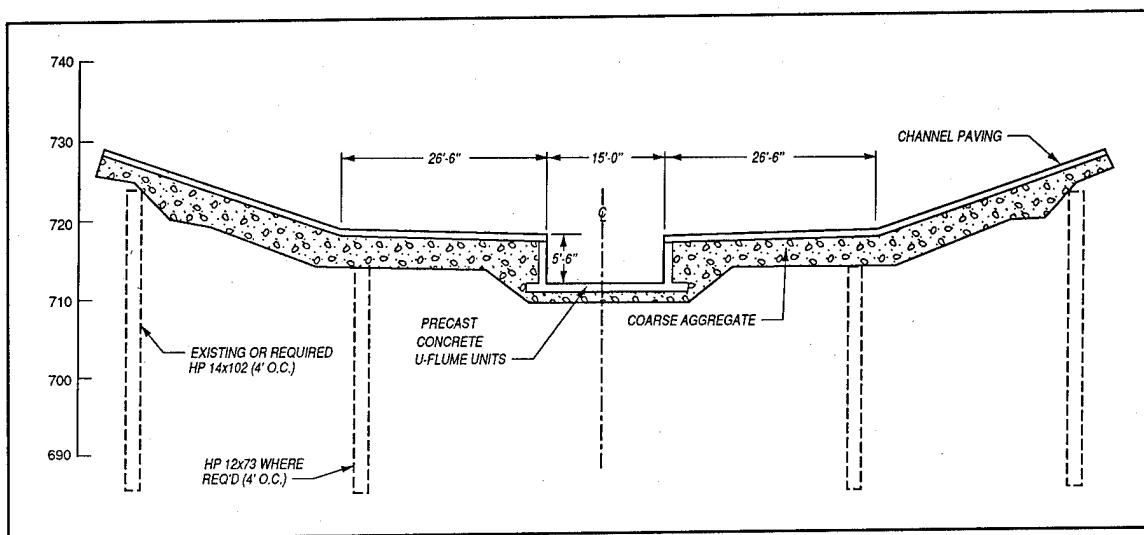

Figure 84. Cross section of precast low-flow channel, Blue River Channel (after Mitscher 1991)

The relative merits of both low-flow alternatives were evaluated during design of the project. Anticipated advantages of the sheet-pile channel were easier control of river water during construction, reduced excavation, the ability to construct the channel in longer reaches, reduced susceptibility to weather-related delays, and a lower estimated cost. Anticipated advantages of the precast concrete channel included improved quality control of concrete construction, elimination of concerns about pile driving, elimination of pumping during curing of the concrete strut, and straight walls for the channel (Mitscher 1991).

The estimated cost of construction for the sheet-pile channel was \$6,035,000 compared with \$8,970,000 to \$11,651,000 (1991 dollars) for the precast concrete channel depending on how the river water was handled during construction. A Government estimate for the total project cost

(\$31,852,218) was prepared for the sheet-pile channel only, since it was anticipated to have the lowest total cost.

There were seven bidders on the project, and all bids were based on the precast concrete alternate. The bids ranged from \$20,835,073 to \$37,656,066 with four bids below the Government estimate. The low bidder's estimate for the low-flow channel was \$2,000,245, far less than the Government estimate. A comparison of the bids with the Government estimate revealed that selection of the precast concrete alternate was a major factor leading to the bids being considerably lower than the Government estimate. For example, the Government estimate contained \$4,753,800 for steel sheetpiling and \$898,365 for the concrete in the strut, while the low bid contained just \$1,057,500 for the precast concrete sections. Also, the Government estimate for water control was \$1,017,000 compared to the low bid of \$400,000.

During discussions, some of the bidders indicated that their estimates showed that the cost of constructing the precast concrete channel would be about \$2,000,000 lower than that of the sheet-pile channel. Their estimates were based on placing 8 to 10 precast sections per day compared to the Government estimate of 2 sections per day. This difference in production significantly reduced construction time and the cost of water control during construction.

The construction contract was awarded to Ellis Construction in February 1991. Wilson Precast-Prestress Co., Kansas City, MO, was the subcontractor for precasting the concrete channel sections. The reinforced-concrete channel sections (Figure 85) were precast in 5 ft lengths which weighed approximately 11 tons. The concrete in the base slab was placed and cured for 2 days prior to placing the sidewalls. A concrete compressive strength of 4,000 psi at 28 days was specified; however, strengths routinely approached 8,000 psi. Six channel sections were precast daily and stored in the precaster's yard.

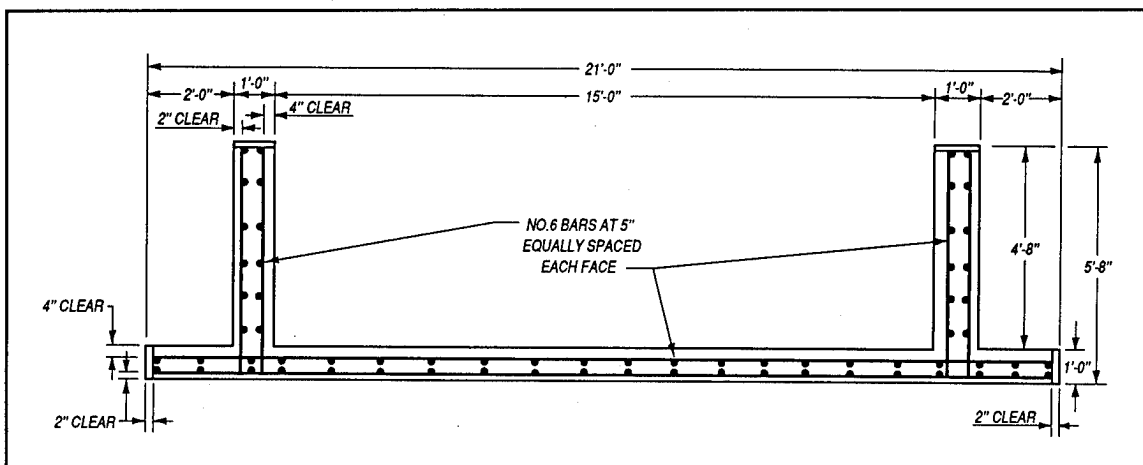

Figure 85. Precast concrete low-flow sections, Blue River Channel (after Mitscher 1991)

The precast sections were shipped, two at a time, by truck to the construction site as required, where they were offloaded with a crane and positioned in

the channel on a crushed rock subfoundation (Figures 86). A total of 700 precast sections were installed with daily placement rates ranging from 12 to 46 sections (Figure 87). The major advantages of precast concrete in this application included low cost, rapid construction, and ease of construction. Also, the use of precast concrete allowed the contractor to divert river water into the channel sections immediately following installation (Figure 88).

Sydney Drainage Channels

Heavy rains in Sydney, Australia, during 1984 caused floods in excess of the 100-year flood. The resulting damage to large areas prompted the Sydney Water Board to initiate an urgent drainage works program to alleviate the flooding problems. The Board's drainage system consists of 69 stormwater channels with a total length of approximately 200 miles. A Drainage Action Program was set up by the Board to address some of the more severe flooding problems in the metropolitan area. This program included 29 major channel expansion projects. Several innovative construction techniques were used to solve problems such as those created by varying soil conditions, excavating in close proximity to built-up areas, unusually wet weather patterns, and demanding traffic conditions (Grad 1992).

The traditional open-trench method for channel construction across a roadway was considered to be too slow and labor intensive for busy urban streets and railway lines. Therefore, it was decided to use precast concrete box units, which were installed by jacking under existing roadways. Precast units up to 16.4 ft wide and 6.5 ft deep were installed with this method. Where the soils were not suitable for safe jacking, the trenching method was used with precast box units installed on prepared foundations. In tidal channels, where each operation had to be completed during low-tide periods, gravel encapsulated by geotextile filter fabric was used to form the foundation mattress. Installation of a heavy plastic sheet on top of the mattress allowed placement of a thin protective layer of concrete almost immediately prior to the next high tide. This method of preparing the foundation and the use of precast units up to 11.8 ft wide by 10.8 ft deep and 4 ft long (Figure 89) dramatically increased the rate of channel construction. In nontidal projects, the gravel mattress was replaced with no-fines concrete wrapped in filter fabric. In some projects where the available easement permitted channel enlargement, L-shaped precast units (Figure 90) were used to accelerate construction.

Installation of the precast units on prepared foundations essentially eliminated the need for temporary shoring and supports, thus increasing the rate of construction. Also, the installed precast units could be used immediately to safely handle flows associated with unexpected storms. The total cost of the program was \$61,000,000, which was \$20,000,000 less than the original estimate.

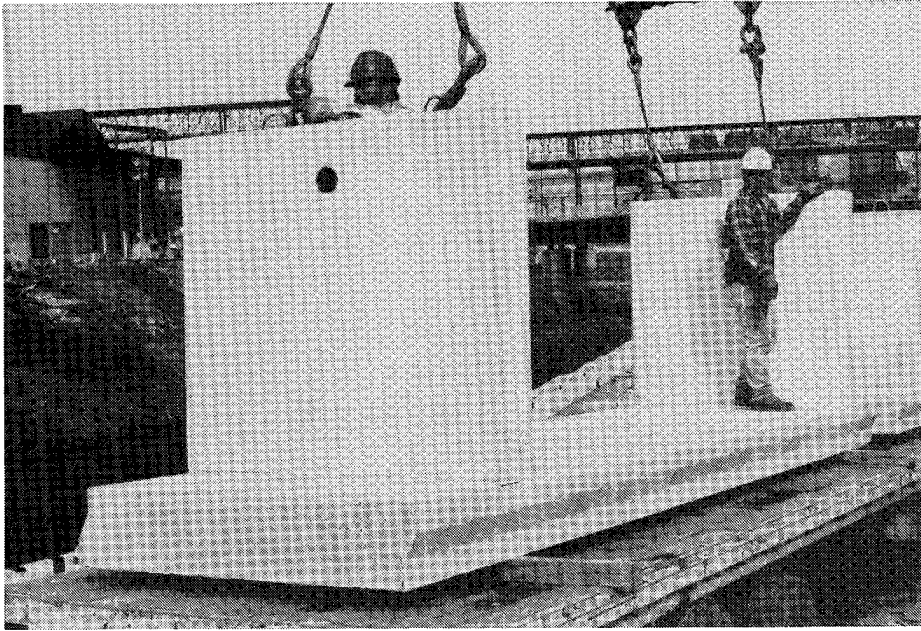

Figure 86. Channel section delivery and installation, Blue River Channel

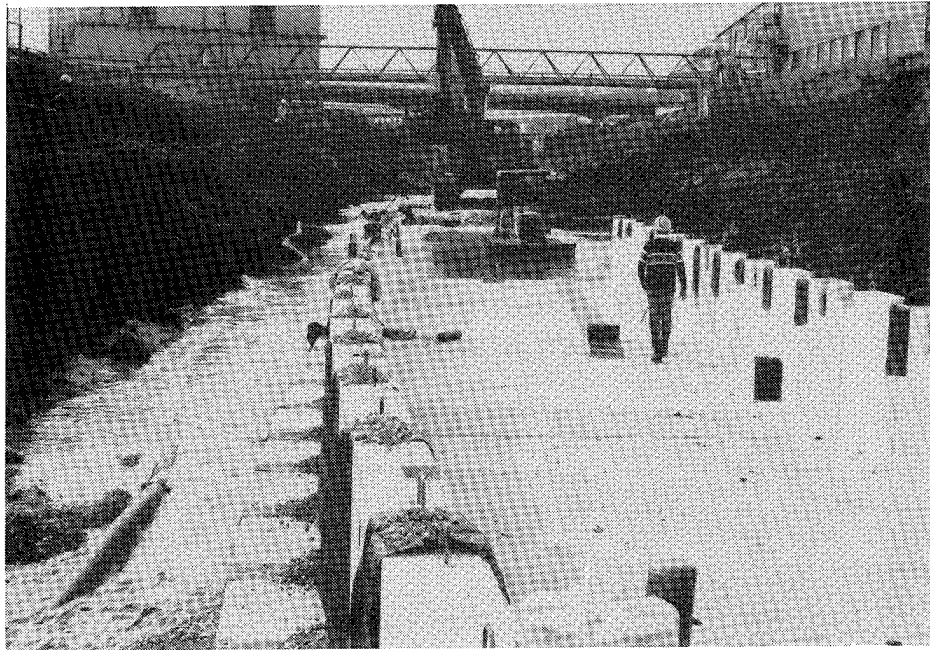

Figure 87. Channel sections in place, Blue River Channel

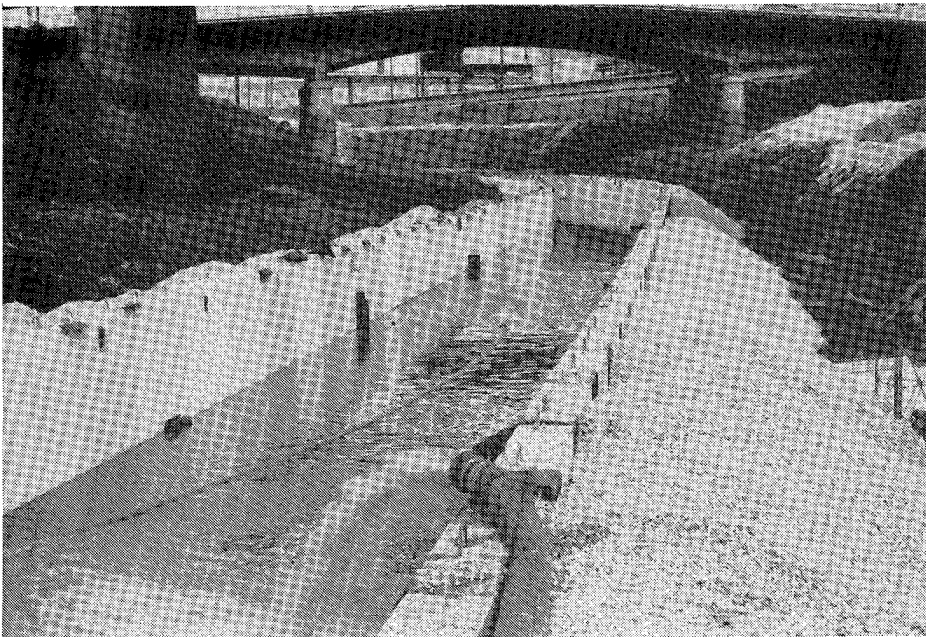

Figure 88. Diversion of river water through channel sections, Blue River Channel

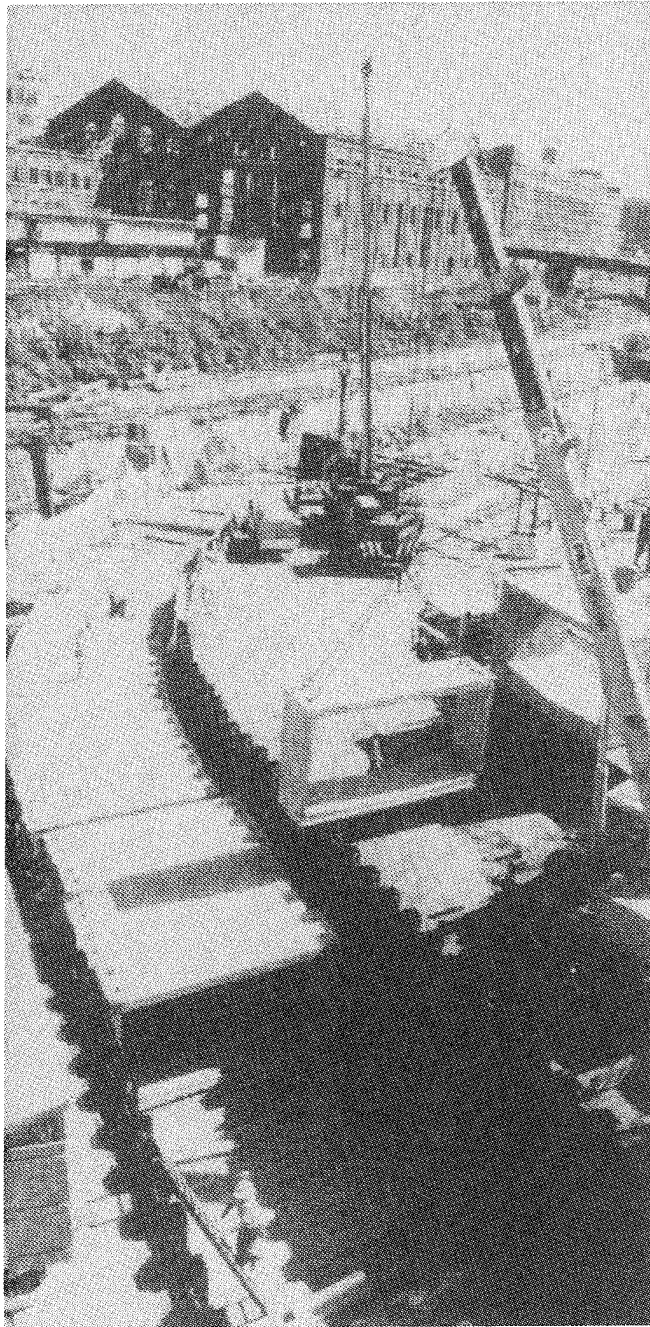

Figure 89. Precast box units, Sydney Drainage Channels (from Grad 1992)



Figure 90. L-shaped, precast channel units, Sydney Drainage Channels (from Grad 1992)

El Dorado Flume

In October 1992, a major forest fire in El Dorado County, CA, destroyed about 1.25 miles of wooden flume used by the Pacific Gas and Electric Co. (PG&E) to carry water to a hydro-electric powerhouse and to a local irrigation district. Ben C. Gerwick, Inc., was engaged by PG&E to evaluate the feasibility of replacing the missing flume sections with precast concrete. Because of the rough terrain and limited access to the canal, the replacement sections were to be installed with helicopters. This installation procedure limited the weight of individual flume sections to 11,000 lb. Gerwick's study indicated that the weight restrictions could be satisfied by precasting the units with lightweight concrete in 8-ft lengths (Firth 1994).

Since reconstruction had to be completed by 1 December 1993, PG&E solicited proposals from a select list of contractors to design and construct the 700 sections required for the project. The Pomeroy Corporation, Petaluma, CA, submitted the successful proposal. The contractor procured 310 lin ft of steel forms which permitted precasting of 31 flume units daily (Figure 91).

The flume units were transported by truck from the precasting facility to a staging area as near the site as practical. The precast units were then transported to the site by helicopter and lowered directly onto foundations previously installed by PG&E. This method of installation proved to be very successful, and the helicopters were usually able to make a round trip in less

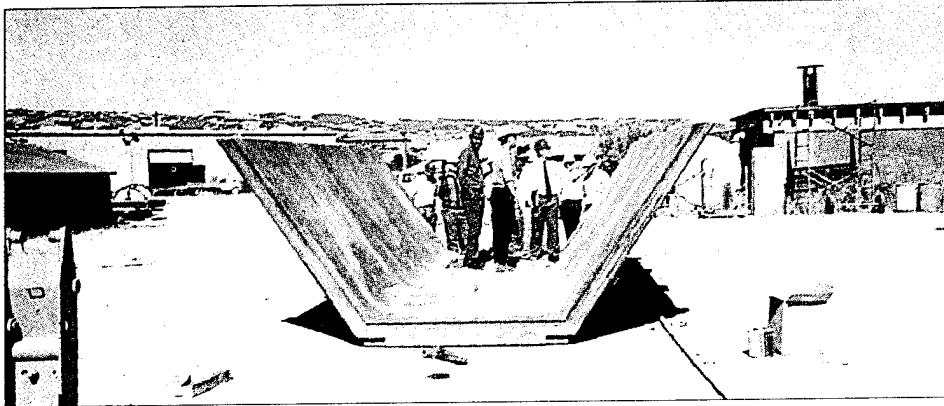

Figure 91. Precast concrete sections, El Dorado Flume (from Firth 1994)

than 7 min. Joints between the precast units were filled with a joint sealant. All of the precast units were in place by late November 1993.

Mississippi River Channel

The Corps of Engineers' Lower Mississippi Valley Division uses huge squares of precast concrete mats to stabilize the Mississippi River and keep it from changing course. This process has evolved over the past century from woven willow mats weighted with stones to the present day method of flexible concrete mats.

The concrete panels, which are 4 ft long by 18 in. wide, are precast in steel forms. The concrete is reinforced with stainless steel wire, which extends from each panel and is used to tie the panels together to form articulated mats. Sixteen panels form a square (Figure 92). Following precasting, the mats are stored until needed for use. Most installation is done during the low-water season, usually July through December.

Before the mats can be placed, the site usually has to be excavated to provide a stable slope for a layer of gravel, which forms a base for the mats. The mats are transported to a site on barges. A mat-sinking unit wires the squares of mat together to form flexible revetment and lowers them into the water (Figure 93).

Approximately 1,000 miles of riverbank is being protected with this precast concrete mat system with an annual program cost of almost \$100 million (*Engineer Update* 1988).

Mill Creek Channel

The Mill Creek Local Flood Protection Project is located in Hamilton County in southwestern Ohio, near Cincinnati. Mill Creek runs parallel to Interstate 75 and Conrail's North and South Mainline Railroad tracks. The

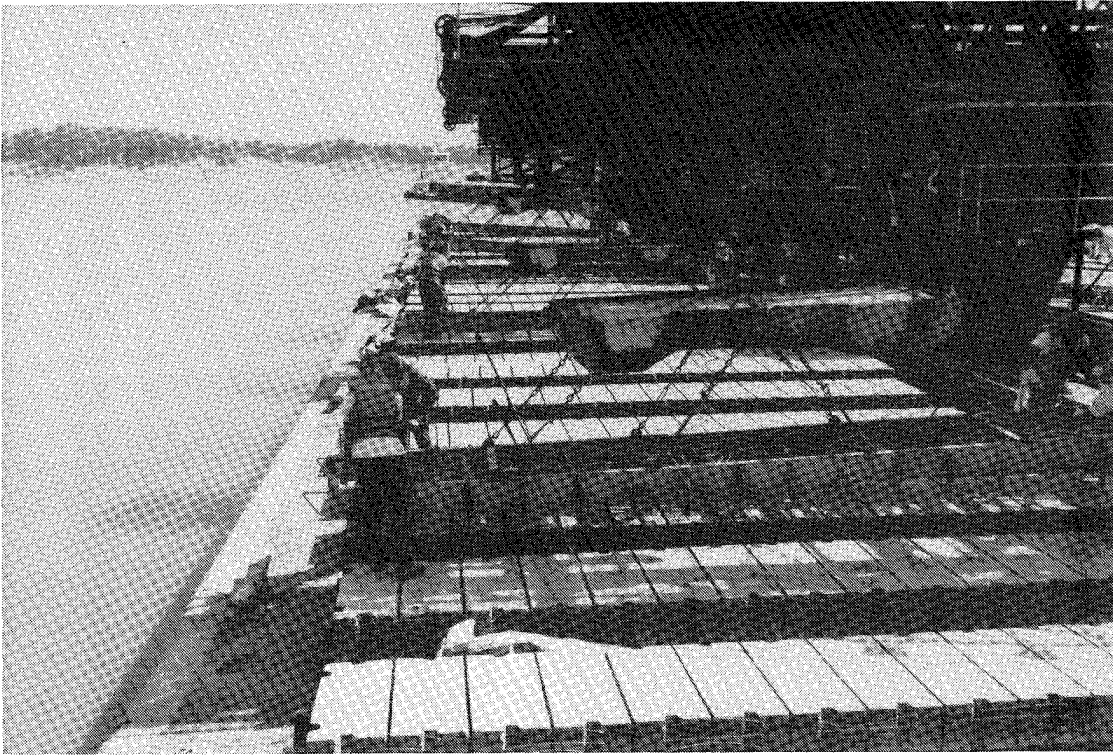

Figure 92. Squares of precast concrete mats prior to sinking, Mississippi River

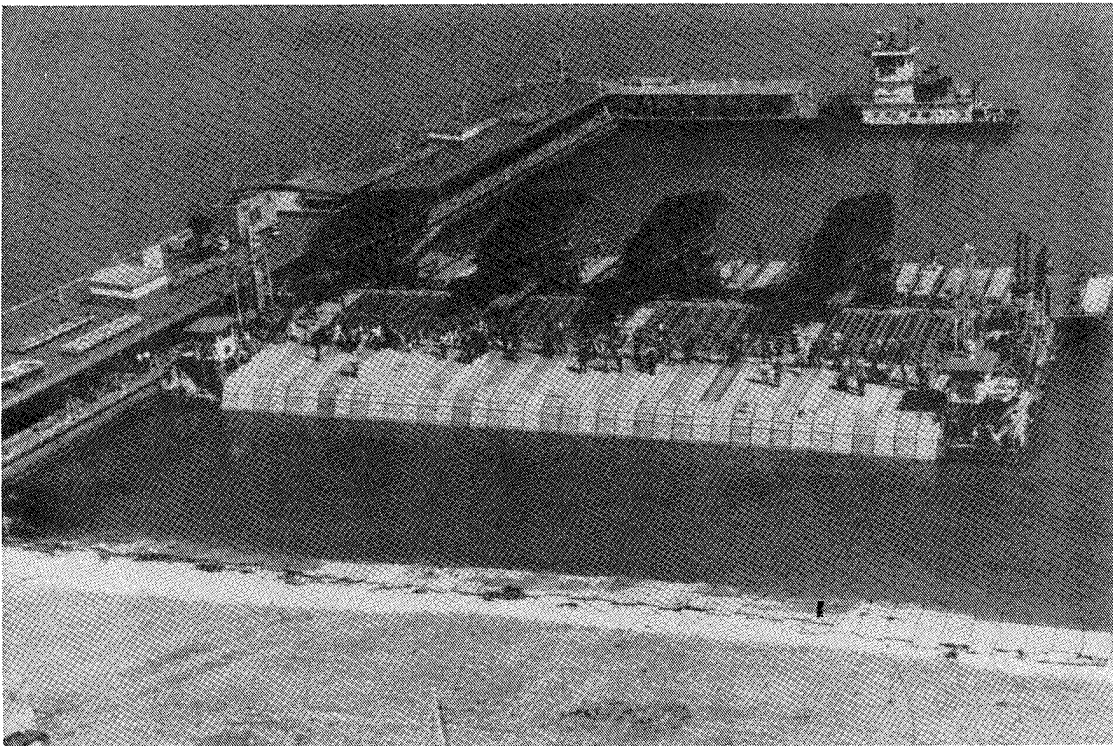

Figure 93. Precast concrete mat-sinking operation, Mississippi River

creek is 28 miles long from its source to its confluence with the Ohio River and has a drainage area of 165 square miles. Sections of the Mill Creek Channel were widened or deepened to provide a 50-year level of protection to the surrounding area (Beyke 1991).

Because railroad tracks, buildings, and streets were close to the banks of Mill Creek, two sections of the project required vertical retaining walls.

The original design for the project was based on a steel sheet-pile retaining wall, cantilevered wherever possible, and anchored with wales wherever necessary. However, subsequent geotechnical explorations revealed that the top-of-rock elevation was higher than the stream invert, which precluded the driving of steel piles. After several alternatives were considered, an anchored post-and-panel retaining wall was chosen for the final design (Beyke 1991).

The posts were steel H-piles embedded in concrete caissons on 6-ft centers. In section 2 of the project, the 2-ft-diam drilled caissons were filled with concrete to within a foot of the channel invert. Precast concrete panels were used to span the area between the posts. Placement of the panels started at the top of the cast-in-place concrete and progressed upward. Because of the height of the wall, rock anchors were placed beside H-piles to increase resistance against the horizontal earth pressure. Approximately 4,500 bank-ft of retaining wall was readily constructed under restructure conditions, and this type of wall is recommended for similar applications (McClellan 1985).

A similar design was used for the 2,490 ft-long retaining wall in Section 1 of the Mill Creek Project. The H-pile posts in this section were embedded in 3-ft concrete caissons drilled into rock. The posts were designed as vertical beams supported horizontally by rock at the bottom and by wales at the top. The wales were supported by rock anchors spaced on 6- and 12-ft centers. High-capacity strand anchors ranging in size from 6-strand (design load 246 kips) to 12-strand (design load 492 kips) were used to construct this portion of the wall (Beyke 1991).

Joliet Channel Wall

Joliet Channel walls are located along both banks of the Illinois Waterway through the city of Joliet, IL. The walls, constructed during the early 1930s by the State of Illinois, were transferred to the Corps of Engineers when the State was unable to complete the project. Currently, the project is maintained by the Rock Island District.

The concrete gravity wall on the left bank is a true water-retaining structure. The pool elevation is 4 ft below the top of the wall. The top elevation of the wall is from 8 ft to about 30 ft higher than the adjacent landside ground elevation. The base of the wall contains a large arch storm sewer that is formed into the gravity section.

The concrete gravity wall on the right bank, which serves principally as a retaining wall, has a small storm sewer built into the net section. The ground adjacent to the wall is generally above the pool elevation. The top of the wall is 3 ft wide with a vertical river face and a sloping landside face. The slope of the landside face varies from 1 on 2 to 1 on 1.75.

A condition survey was performed by the Rock Island District in 1984. The survey included a review of the construction history, a comprehensive visual examination, sounding the surfaces with a steel hammer, and a coring and testing program. Approximately 740 monoliths were surveyed. Cracks, drummy areas, and other distress were noted on a customized inspection form with sketches to determine the areal extent of the deterioration. Megascopic and petrographic examination of concrete cores provided information on the depth and cause of the deterioration. Compressive strength tests were used to evaluate the quality of the underlying concrete.

The condition survey revealed that seepage along monolith and construction joints combined with cycles of freezing and thawing had resulted in extensive deterioration of the exposed concrete (Figure 94). The maximum depth of the deterioration was 2 ft. The compressive strength of the interior concrete, which varied from 4,400 to 8,200 psi, indicated that the strength and quality of the underlying concrete was satisfactory. In contrast to the exposed concrete, those sections of the wall insulated from freezing and thawing by back-fill had escaped deterioration.

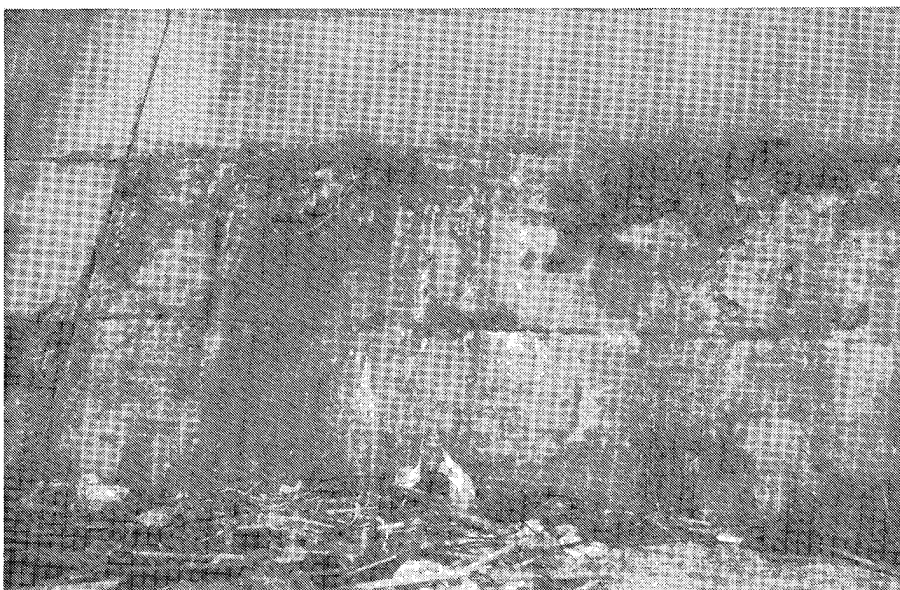

Figure 94. Typical concrete deterioration, Joliet Channel Wall

Stability analyses, which considered the depth of deterioration, confirmed that the gravity walls founded on bedrock were stable. Therefore, it was

decided that any repairs should provide aesthetically acceptable insulation for the exposed concrete walls to reduce the potential for additional freeze-thaw deterioration. A combination of conventional repairs, earth backfill, and earth-filled crib walls would meet the criteria. Earth backfill was the most economical method of providing insulation. However, backfill was not feasible in all reaches because of buildings near the wall and other right-of-way restrictions. Conventional repairs, which included removal of deteriorated concrete and replacement with air-entrained, cast-in-place concrete and crib-wall construction, were specified for the restricted reaches. The contractor submitted a value engineering proposal to eliminate the crib-wall construction and recommended using a precast concrete panel system that included insulation and drainage provisions (Figure 95).

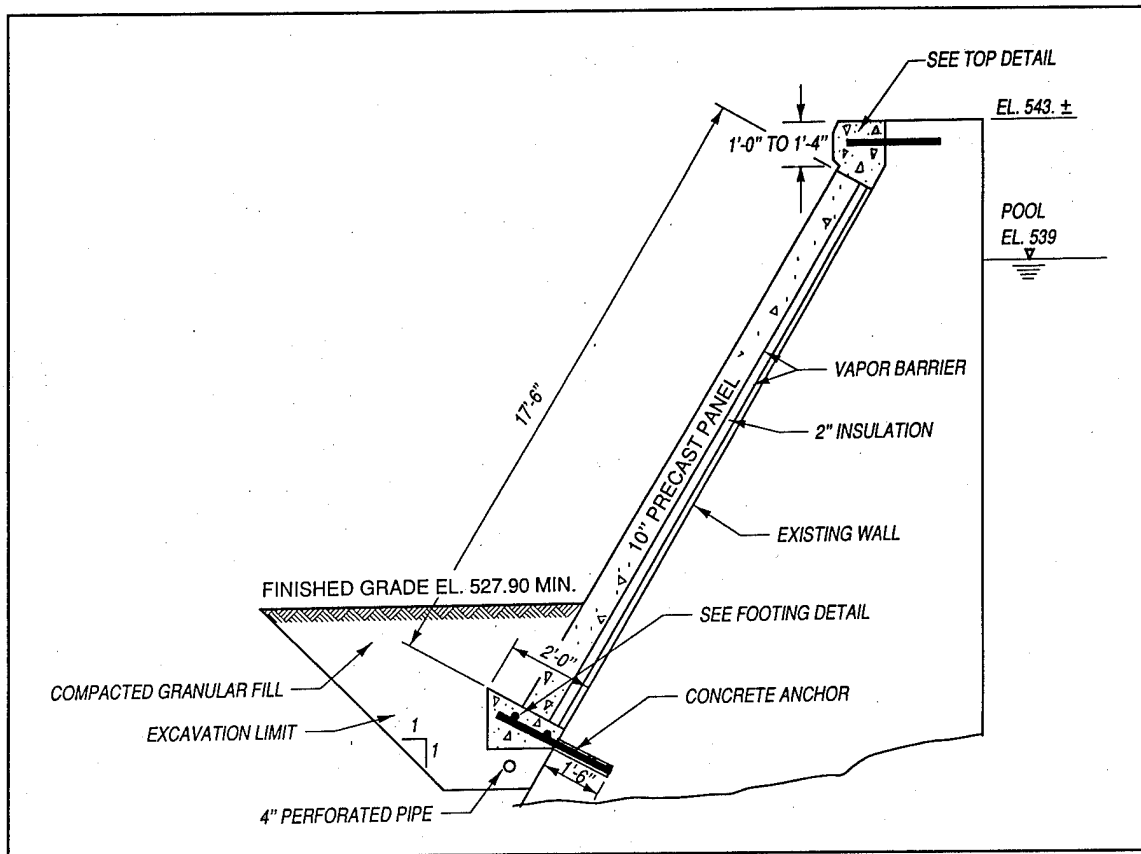

Figure 95. Typical repair section, Joliet Channel Wall

The total length of the precast-panel repair was 1,145 ft. The construction sequence began with soil excavation to accommodate the precast-panel footing and a perforated pipe drainage system (Figure 96). Compacted granular fill was placed around a 4-in. perforated drain pipe and brought up to the bottom elevation of the concrete footing. The cast-in-place footing used to support the precast-panel footing was anchored to the existing wall with No. 6 bars embedded 1.5 ft on 4-ft centers. A 3-in.-diam pipe was placed vertically through the footing on 15-ft centers. The vertical pipes were used to collect

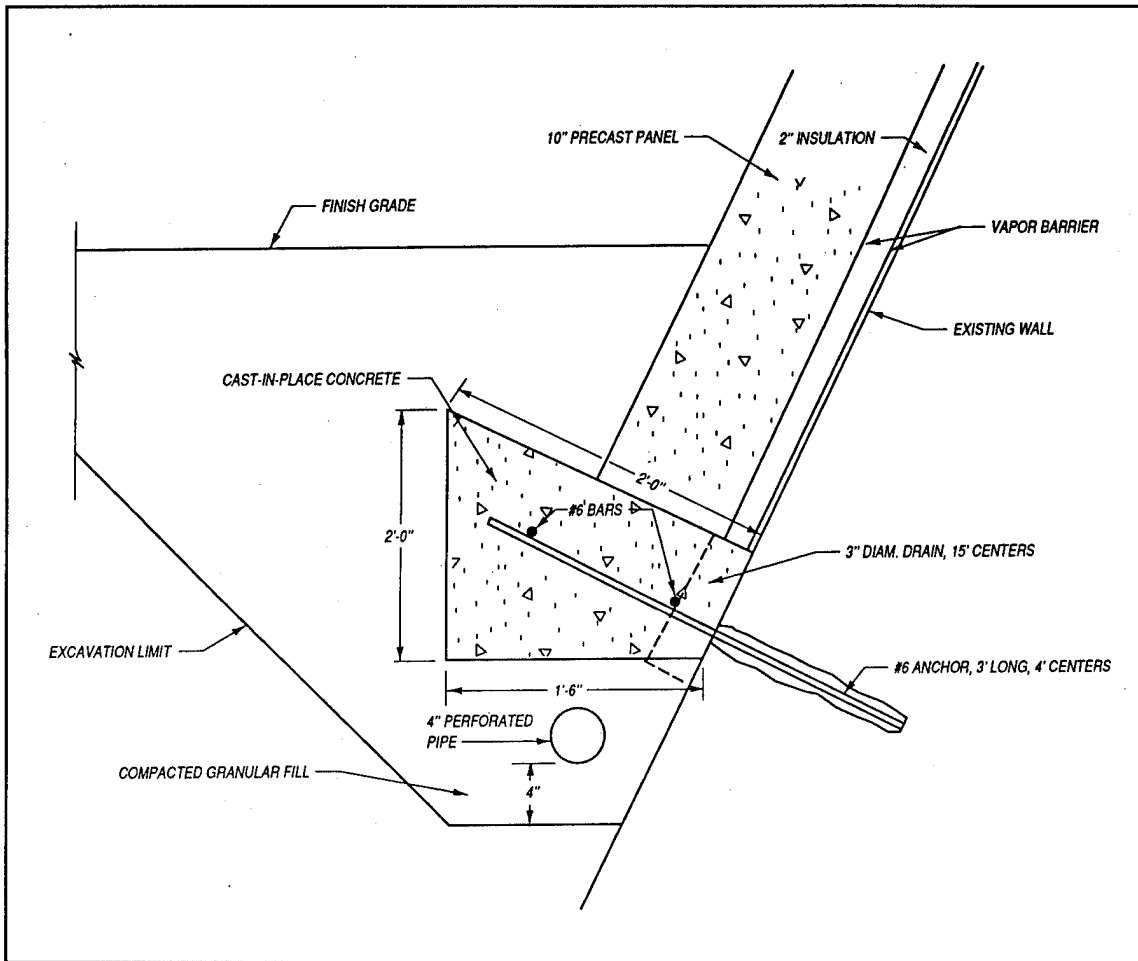

Figure 96. Footing detail, Joliet Channel Wall

any water seeping through joints in the wall. The water was to flow through the granular fill and into the 4-in. drain.

Reinforcing near the front face of the panel consisted of No. 5s on 12-in. centers each way. Lifting inserts were embedded on the front face. No. 4 reinforcement was concentrated near the lifting inserts on the backside.

Concrete panels were cast onsite in horizontal lifts. Form oil was used as a bond breaker to allow separation of panels following curing. As many as six panels were cast on top of each other.

A 10-mil-thick polyethylene vapor barrier was placed on the existing surface of the wall. Deteriorated concrete was not removed. A 2-in. thickness of extruded polystyrene rigid insulation was placed on the vapor barrier (Figure 97). The insulation was then covered with another 10-mil-thick polyethylene vapor barrier.

The 10-in.-thick by 17.5-ft-high precast panels were set into place on the footings and against the face of the vapor barrier/insulation surface. A crane



Figure 97. Placing insulation over first vapor barrier, Joliet Channel Wall

with a special lifting apparatus was used to lift the panels from the horizontal beds and position them on the wall (Figure 98). Most of the panels were 30 ft long and weighed approximately 33 tons each. Each panel had a groove in one end and a partially embedded 3/8-in. PVC waterstop in the other (Figure 99). The groove accommodated the waterstop from the adjacent panel.

Once the panels were positioned on the wall, expansion-joint material was placed between the panels, and nonshrink grout was placed in the groove to encapsulate the waterstop. The panels spanned the vertical monolith joints in the existing walls. A cast-in-place concrete cap was constructed on top of the precast panels (Figure 100). The cap provides a wider walking surface and serves as a barrier against surface water entering the area between the precast panels and the wall.

The contractor's bid price for 20,400 sq ft of precast-concrete panel wall including polyethylene, insulation, anchors, drainage system, concrete footing,

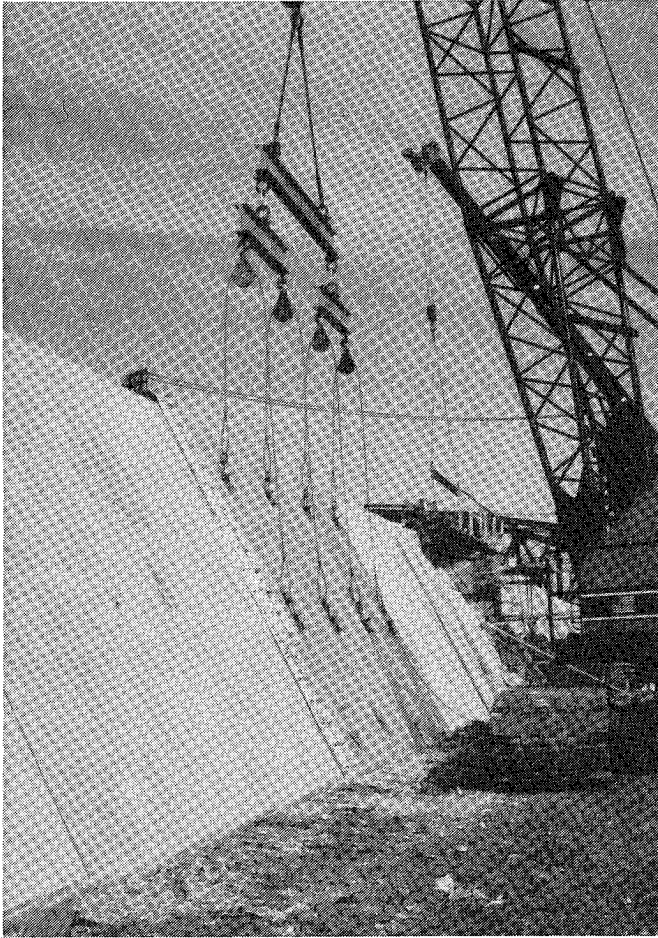

Figure 98. Precast panels set into place on concrete footing, Joliet Channel Wall

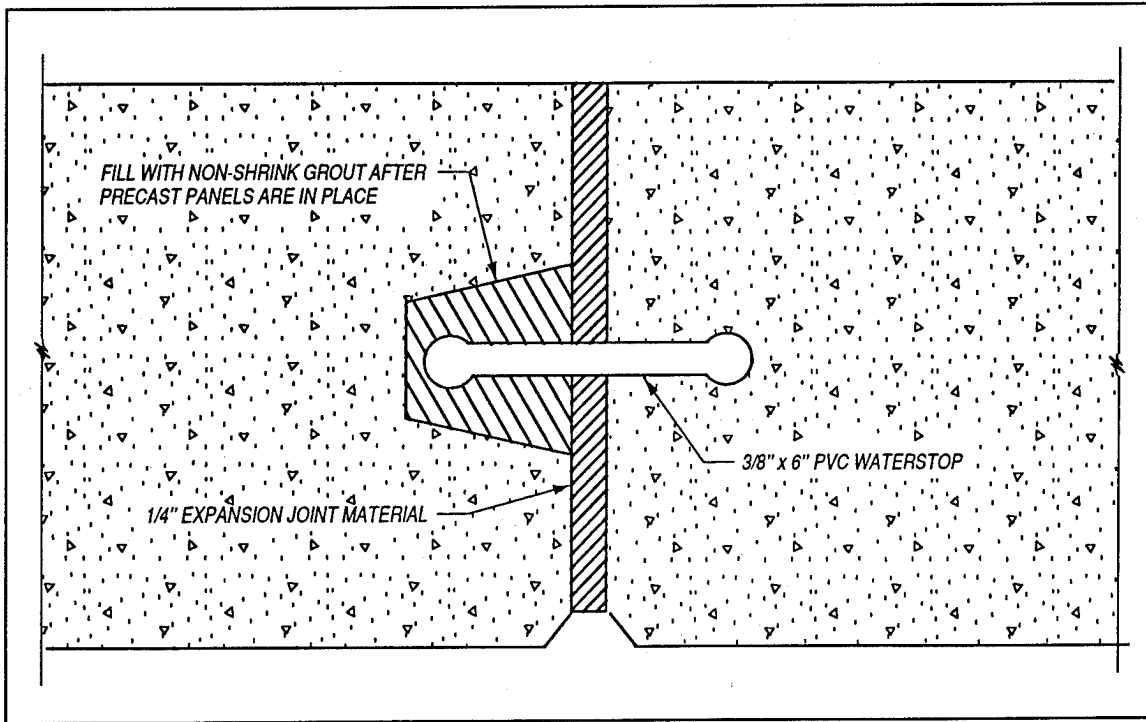

Figure 99. Top detail, Joliet Channel Wall

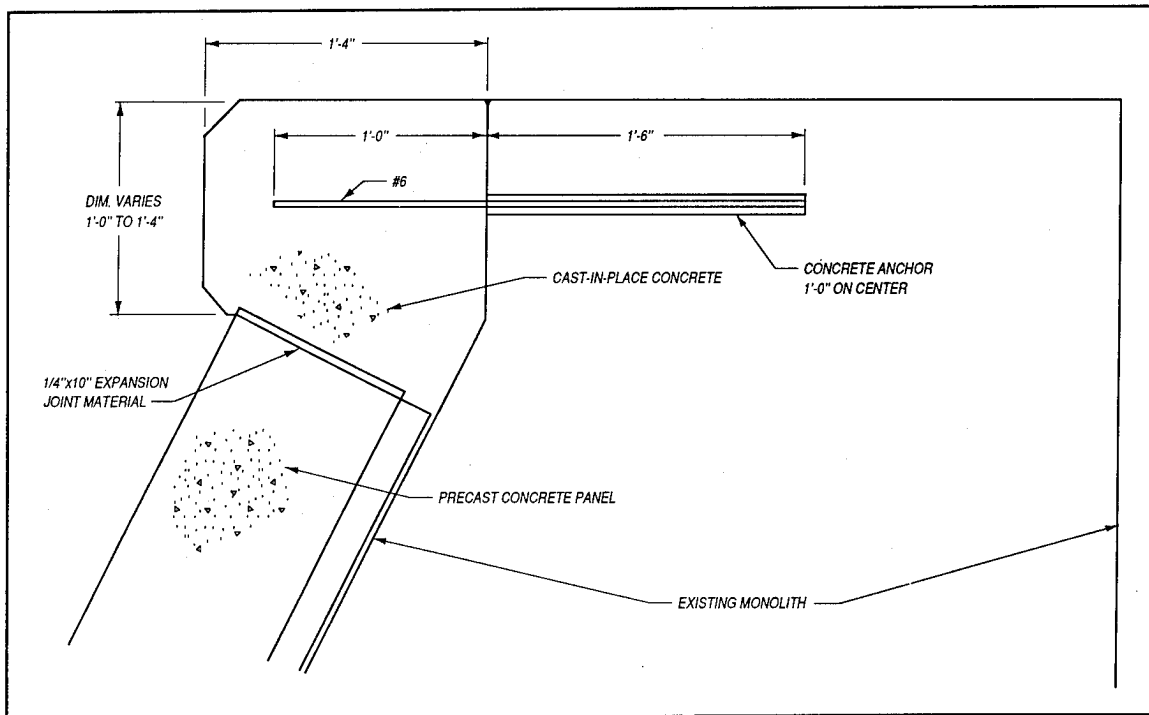

Figure 100. Joint detail, Joliet Channel Wall

and concrete cap was \$392,563. The panels have been in place since August 1987 and are performing satisfactorily (Figure 101).



Figure 101. Completed rehabilitation, Joliet Channel Wall

West River Channel Wall

A precast concrete channel wall was constructed along the West River in New Haven, CT, as part of the overall local flood-protection project. Over 18,000 sq ft of Doublewal, a proprietary retaining wall system, was used to construct the curved wall, which is 16 ft high and approximately 1/4 mile long. Doublewal consists of interlocking precast concrete bins or modules stacked on top of each other and filled with compacted fill to form a gravity wall (Figure 102). The precast modules are 4 ft high by 8 ft long and vary in width from 4 to 8 ft. Since the wall is located in an urban area, the Corps of Engineers decided to create a river walk by constructing a sidewalk with fencing and lighting on top of the wall (Figure 103).

River des Peres Channel Wall

The River des Peres, which enters the Mississippi River approximately 23 miles downstream from the confluence of the Mississippi and Missouri Rivers, has a 111-square-mile watershed, which includes portions of St. Louis and unincorporated St. Louis County. The flood-control project for the area is divided into two sections: Deer Creek and University City. A 0.38-mile stretch of the University City section is in need of channel improvement.

This section is located in a densely populated area with limited construction space. It is also a cost-sharing project; therefore, the Corps of Engineers has to find the most cost-effective method for constructing a channel wall within

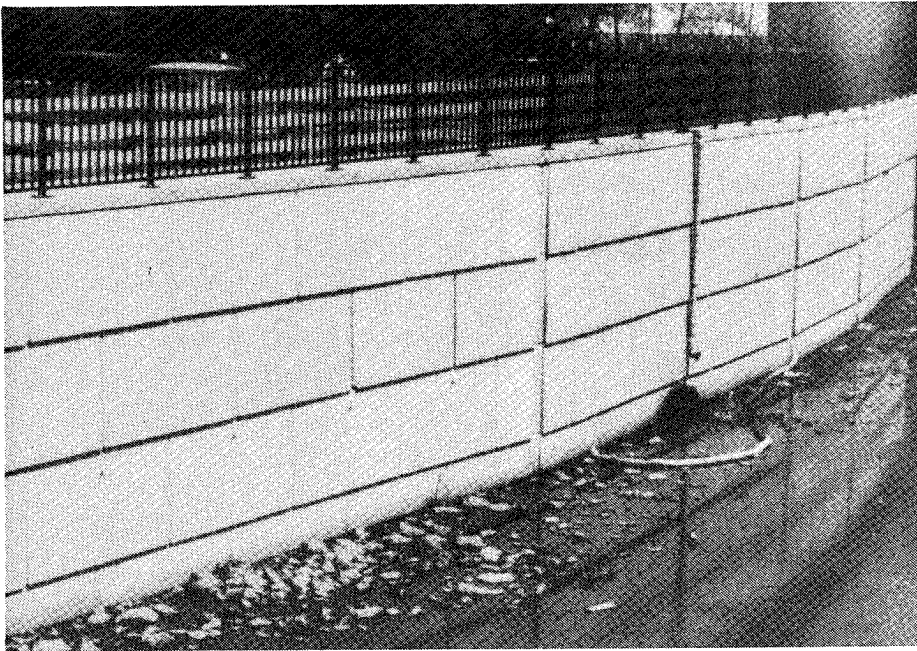

Figure 103. Completed project, West River Channel Wall

the constraints of this project. The wall is to be 15 ft high. If it is constructed with a smooth surface, the width is to be 55 ft; if with a rough surface, such as gabions, 65 ft. The bottom of the footing is to be 3 ft below the creek bed because of scour and the frost line. The top of rock is approximately 5 ft beneath the creek bed. Ross (1991) described the various innovative methods researched and evaluated for construction of the channel wall.

Five wall systems were considered: Armco Bin-Type, Doublewal, Mechanically Stabilized Earth, TechWall, and WaterLoffels. Design procedures were similar for all wall systems and included bearing capacity, sliding, and overturning. All calculations, those done with the Corps of Engineers' computer program CSLIDE and by hand, followed Corps of Engineers and Naval Facilities criteria. Each wall layout was superimposed onto a typical cross section of University City. Cost comparisons were made based on quantities of excavation, backfill, premanufactured materials, and other items pertinent to each type of wall.

Armco Bin-Type Retaining Walls consist of adjoining closed-face bins, or cells 10 ft long, that are filled with soil to form a gravity wall. Typically, the bins consist of lightweight steel members that are bolted together at the project site. However, for this project, precast concrete panels were selected for the front facings. This particular design required a 12-ft base to support the bin and pervious infill. Bin-Walls can withstand temperature variations and the effects of ice and snow. Also, the use of galvanized steel helps prevent corrosion. The quoted cost of \$20.00 per sq ft for the Bin Wall did not include excavation. The Corps' estimated cost for constructing a channel wall of this type was \$1,800,000.

Doublewal is a gravity retaining wall system consisting of precast, interlocking reinforced concrete modules (Figure 104) which vary in size depending upon the application. Typical modules are 4 ft high by 8 ft in length and vary in width from 4 to 20 ft. The wall is supported on a cast-in-place concrete base. This particular wall required a 10-ft base. Once a module is in place, the unit is filled with compacted earth or crushed stone. According to the supplier, a crew of five can install approximately 2,000 sq ft of Doublewal a day. The excavation cost for this wall would be 15 percent less than that

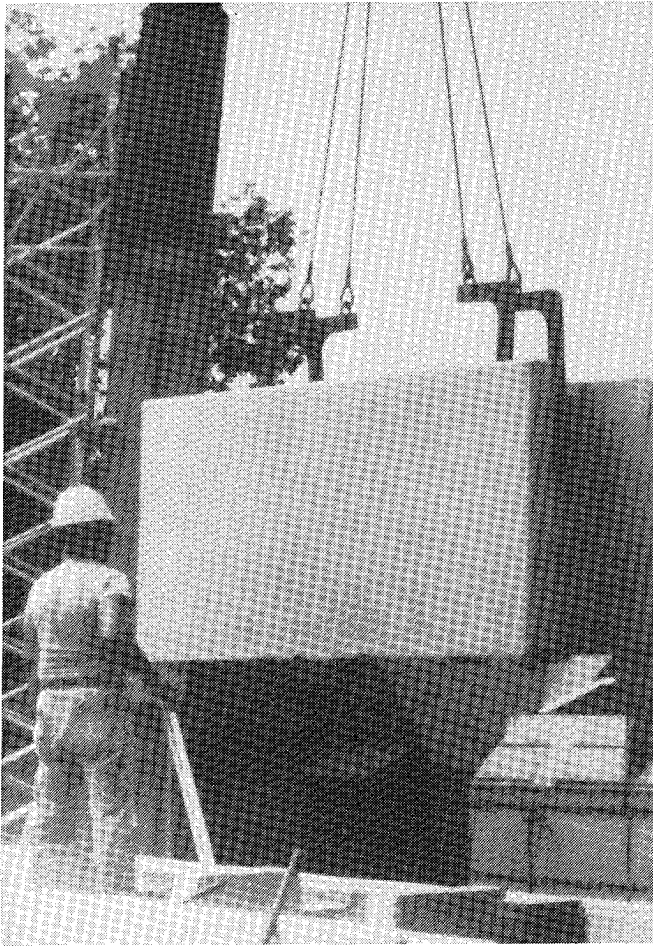

Figure 104. Typical Doublewal precast concrete modules

for the Bin-Wall, but the quoted price for materials (\$27.00 per sq ft) was considerably higher than that for the Bin-Wall. The Corps' estimated cost for construction was the same for both types of wall.

The mechanically stabilized backfill wall evaluated for this project is manufactured by the Reinforced Earth Company. The system consists of vertical precast concrete panels anchored with horizontal steel strips embedded in compacted backfill (Figure 105). Components for this wall system include a cast-in-place concrete leveling pad, standard precast concrete panels,

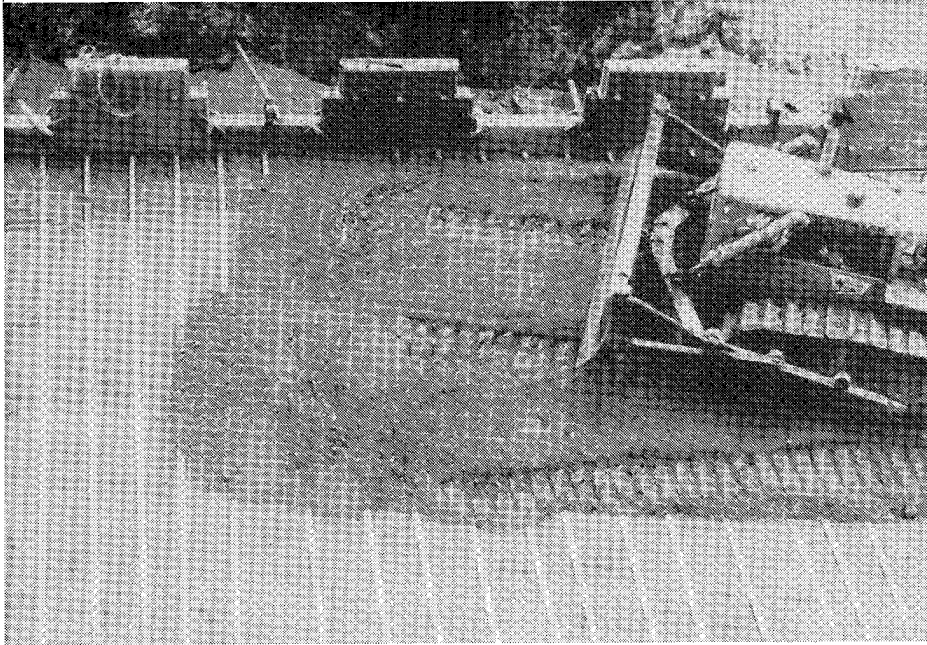

Figure 105. Typical precast concrete panels used in construction of mechanically stabilized backfill walls

permeable backfill, galvanized steel reinforcing strips, and filter fabric. The length of the reinforcing strips, which varies with the height of the wall, was 12 ft for this particular project. Therefore, the extent and cost of excavation was the same as that for the Bin-Wall system.

The construction sequence is as follows: place and cure the leveling pad, install the first tier of panels, and place and compact the first lift of backfill. Reinforcing strips are then anchored to the panels and covered with another layer of compacted backfill. The next tier of panels is placed, and the procedure continues until the specified height is reached. According to the manufacturer, a contractor can complete 750 to 1,000 sq ft of wall face per shift with a crew of five and standard construction equipment.

The Corps' estimated cost for constructing the channel wall with the mechanically stabilized backfill system was \$1,500,000. The estimated cost savings for this type of wall compared to the Bin-Wall and Doublewal is in the cost of the precast panels and reinforcing strips.

TechWall is a retaining wall system that uses precast reinforced concrete counterfort wall sections and cast-in-place concrete leveling pads and footings. The system was developed by the Reinforced Earth Company for use in areas where difficult excavation or right-of-way restrictions prevent the use of mechanically stabilized backfill walls. Because these walls have heavily reinforced counterforts, the precast concrete facing panels are relatively thin. Once the wall sections are positioned, concrete is placed over the leveling pad

to form a footing. After the footing has cured, a pervious backfill is placed and compacted.

The TechWall requires less excavation than the mechanically stabilized backfill wall, but the cost of the precast counterfort wall sections is higher. The Corps' estimated cost of channel wall construction with the TechWall system was \$1,600,000, or approximately \$100,000 more than the mechanically stabilized backfill wall.

The Waterloffel is a variant of the Loeffelstein, a spoon-shaped, stone product developed in Switzerland. The Waterloffel modules interlock by wings, or ears, on each side and an additional cross-member creates two independent troughs that retain backfill. Waterloffels must be constructed on a slope between 40 and 70 deg. This requirement allows the channel width to decrease from 55 to 45 ft and provides for a 10-ft setback at the top of the wall. However, a slope stability analysis showed that the wall was not stable even at the minimum slope of 40 deg. A cost estimate was not prepared for this type of wall.

Currently, it appears that the mechanically stabilized backfill wall will be used to construct the River des Peres channel wall because it is considered to be the most cost-effective.

Bettendorf Floodwall

The final major contract of the Bettendorf, IA, Local Flood Protection Project was completed in September 1987. The contract was for construction of a line of protection consisting of levees, floodwalls, and closure structures. A portion of the project passes through an area developed as a park. City officials wanted the project to have a minimal impact on the aesthetics of this area; therefore, a folding floodwall was selected for this portion of the project. This structure provides the required degree of protection with minimum visual impact.

The folding floodwall consists of three sections: a permanent, concrete lower section; a hinged, precast concrete midsection; and a hinged, aluminum top section. When the panels are fully erected, they are supported by steel pipe struts. Monolith and panel joints are sealed with rubber seals and closure plates. When the panels are folded, the struts, seals, and closure plates are stored onsite. When folded, the exposed permanent section does not obstruct the view of the Mississippi River.

The lower section of the folding wall is a modified, reinforced concrete T-wall with a 19-ft-6-in. base and a 6-ft-1-in. stem, of which 3 ft 7 in. projects above ground level (Figure 106). The typical 19-ft-long monolith has three hinges (one at each end and one in the middle) anchored into the top of the permanent wall for connection to the precast concrete midsection. When

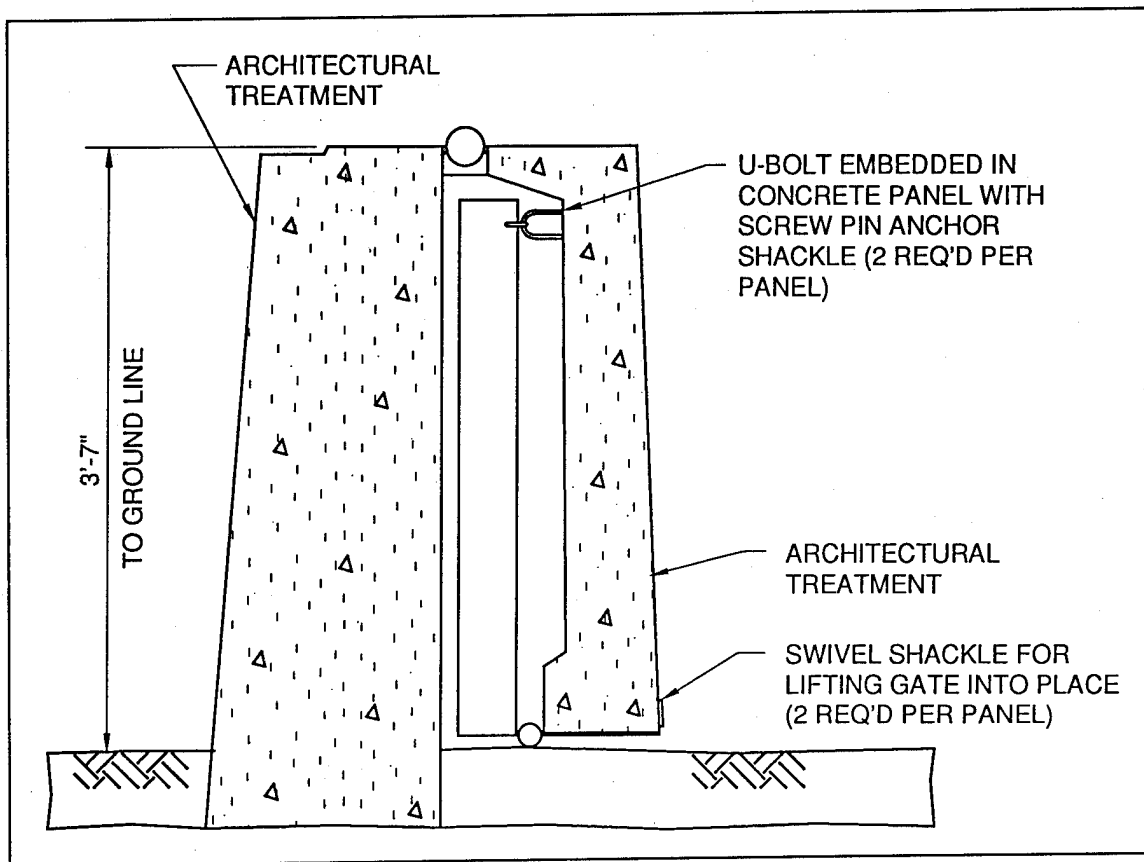

Figure 107. Typical wall section folded position, Bettendorf Floodwall

precast-concrete panel with the aluminum panel remaining folded (Figure 108). When the panel is raised, the exterior struts are installed. When even higher flood levels are expected, the upper aluminum panel is raised, either by hand or by crane (Figure 109). The middle strut is installed on the folding concrete panel, and three additional struts are installed to support the upper aluminum panel. Each time a panel is raised, neoprene seals are placed between the adjacent surfaces. In addition, the gaps between adjacent monoliths are sealed with steel closure plates with neoprene seals attached to them. The pipe struts that support the folding panels are threaded at each end to allow for minor alignment adjustments. Once the folding panels are erected, the pipe struts can be turned, sealing the panels firmly into the seal pads.

The Bettendorf folding wall, being the first of its kind built by the Rock Island District, provided several lessons concerning design and construction. The precision fit between the various components is crucial to the operation of the moving components of the folding wall. Because of irregularities in the formed concrete surfaces and normal tolerances in the dimensions of the embedded angles and channels to which the hinges were attached, an accurate fit in the hinges was not obtained. The result was binding of the hinges. Future construction of this type should require tighter limits on the tolerances of the embedded metals and concrete work or the development of a field-adjustable

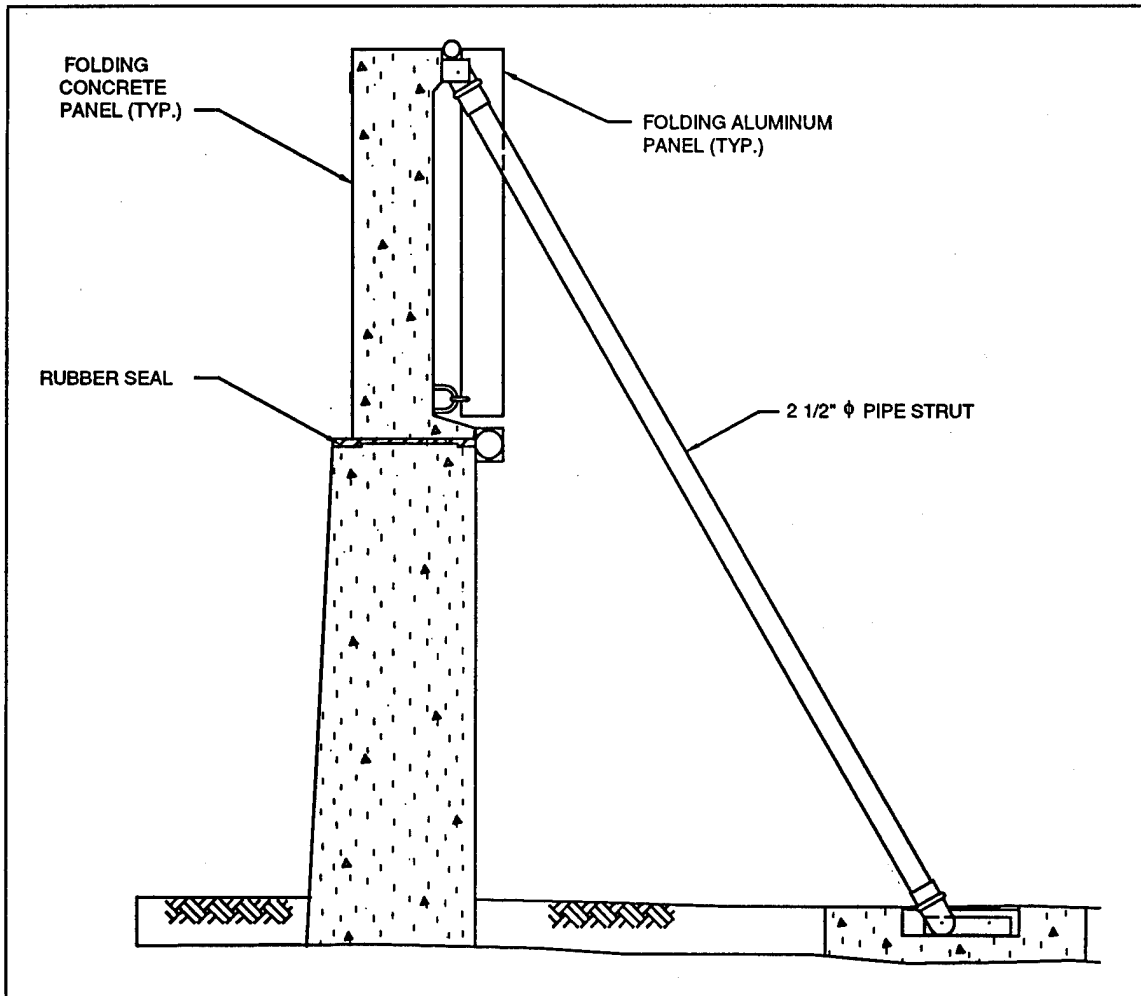

Figure 108. Typical wall section with lower panel erected, Bettendorf Floodwall

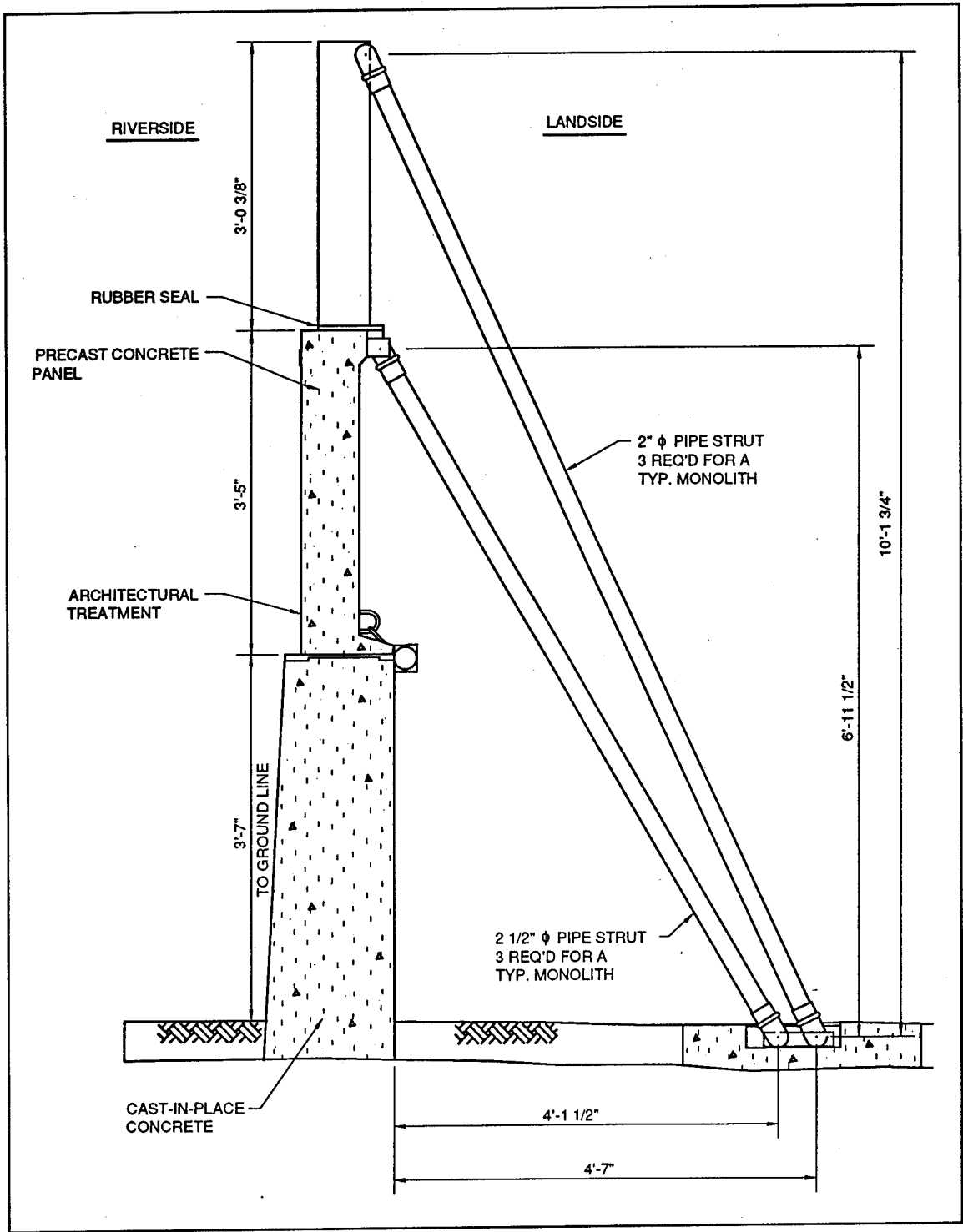

Figure 109. Typical wall section with upper and lower panels erected, Bettendorf Floodwall

hinge. In addition, the use of a smaller two-hinged panel in lieu of the larger three-hinged panel might alleviate the binding in the hinges.

Variations in the dimensions of the embedded metals and concrete surfaces prevented alignment of adjacent panels. The specified seal material proved to be too rigid to conform to the irregularities in the concrete; therefore, the panels did not seal firmly. A contract modification replaced the original 1/2-in.-thick neoprene seal with a softer, more pliable material. The new seal was specified to be a 1-in.-thick, closed-cell, neoprene-expanded rubber that meets the requirements of ASTM D 1056, Class E, Grade 4 (1991). The thicker, softer seal ensured adequate contact between the members and provided a seal able to conform to the irregularities of the components.

The total construction cost for 219 lin ft of folding wall was approximately \$330,000, approximately \$1,500 per lin ft.

Hornell Floodwall

As part of the overall rehabilitation of the Hornell Local Flood Protection Project, Hornell, NY, the concrete floodwalls were repaired by removing the deteriorated concrete and replacing it with shotcrete. The engineers who designed these repairs, while satisfied with the general quality of similar work in the past, felt that the aesthetics of such repairs left room for improvement.¹ Consequently, they designed a precast concrete capstone to be used in combination with shotcreting of the vertical wall surfaces (Figure 110). Typical

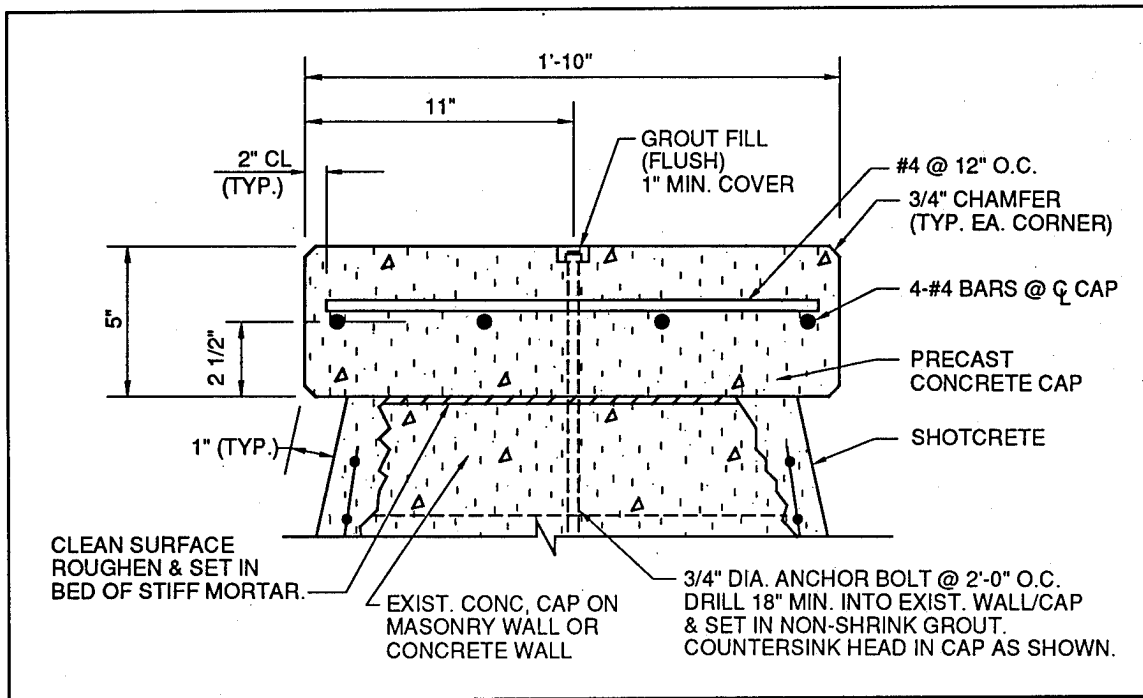

Figure 110. Precast cap detail, Hornell Floodwall

¹ Personal Correspondence, 1991, Kenneth P. Allen, Bergman Associates, Rochester, NY.

precast concrete caps were 5 in. thick, 1 ft 10 in. wide, and 8 ft long. The specified compressive strength of the concrete was 5,000 psi at 28 days. All reinforcing in the caps was epoxy coated.

All loose, cracked, or unsound concrete was removed from the existing wall with a chipping hammer. The wall was then cleaned and roughened by waterblasting. The precast concrete cap was set on a bed of stiff mortar and then anchored to the wall with 3/4-in.-diam bolts on 2-ft centers. The anchors were embedded in nonshrink grout with a minimum embedment length of 18 in. Shotcrete was applied to the vertical surfaces after the precast caps were installed. The regular shape and overhang of the capstones greatly enhanced the appearance of the approximately 875 lin ft of floodwall repaired in this manner (Figure 111).

Pineville Floodwall

In 1946, Pineville, KY, experienced the equivalent of a 20-year flood for that area. Following this destruction, the Corps designed a floodwall to provide protection against another occurrence of this magnitude. In 1977, this floodwall was overtopped. Damages to the city of 3,000 amounted to approximately \$29,000,000. At that time, the Nashville District made plans to upgrade flood protection for Pineville. Gunnels (1991) described the project in detail; this case history is a summary of his report.

The project consisted of realigning and improving the portion US 25 that runs through the city, building a new floodwall on top of the relocated highway embankment, replacing two bridges with taller structures, upgrading the interior flood-control system, raising the Wallsend levee and adding a floodwall along its crest, and constructing nine closures.

Two of the nine closure structures were across railroad tracks through the Wallsend area of the levee/floodwall. Gated structures were selected for the closures because of rapid river rises. Initially, it appeared that the downstream closure site would require a gate 12 ft high and 105 ft wide across six railroad tracks, each at a different level. However, the railroad agreed to revise their tracks so the closures would have to cross only two tracks, both at the same level.

A typical closure structure consists of a concrete sill beam beneath the tracks with piers on either side projecting out of the sill and a gate hinged to one of the piers. Conventional construction of the sill beam with cast-in-place concrete would have taken the railroad out of service for an unacceptable period. Also, site conditions were not favorable for construction of a run-around. Therefore, an innovative closure structure was designed to allow construction with minimal impact on railroad operations. This design consisted of piers on each side of the tracks with their own separate bases and a precast reinforced-concrete sill beam beneath the tracks (Figure 112). The ends of the 3- by 3-ft sill beam rest on seats in the pier bases. H-piles driven under each rail also provide support for the precast beam.

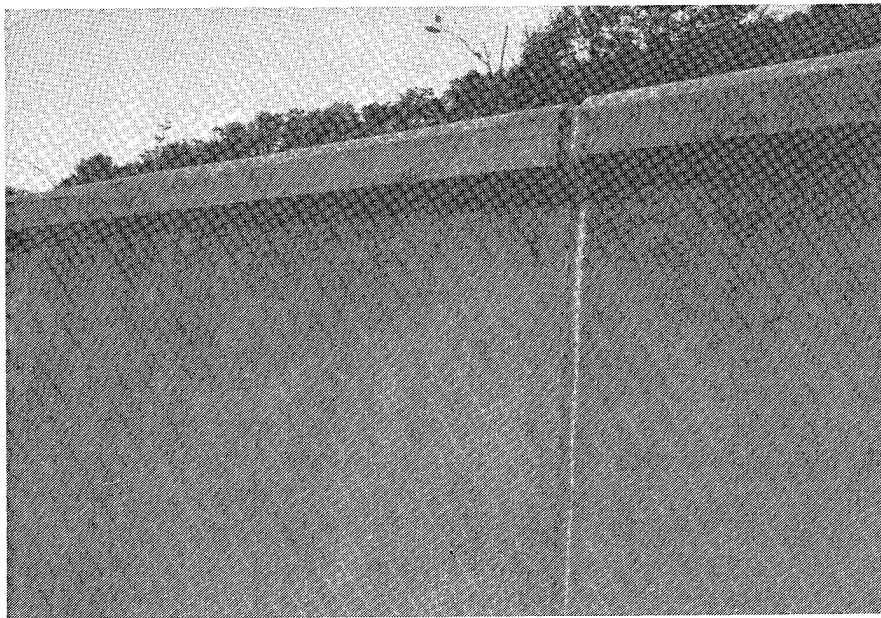
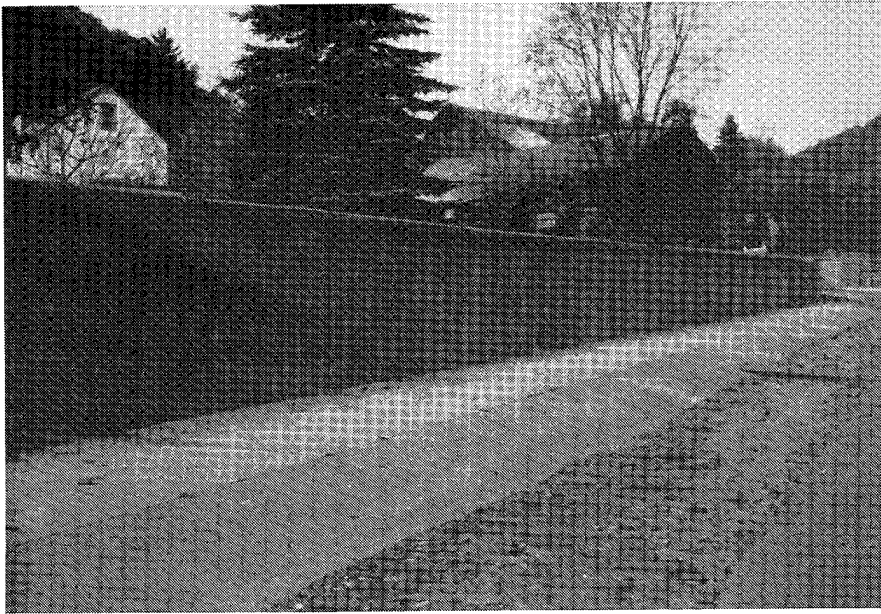

Figure 111. Completed repair, Hornell Floodwall

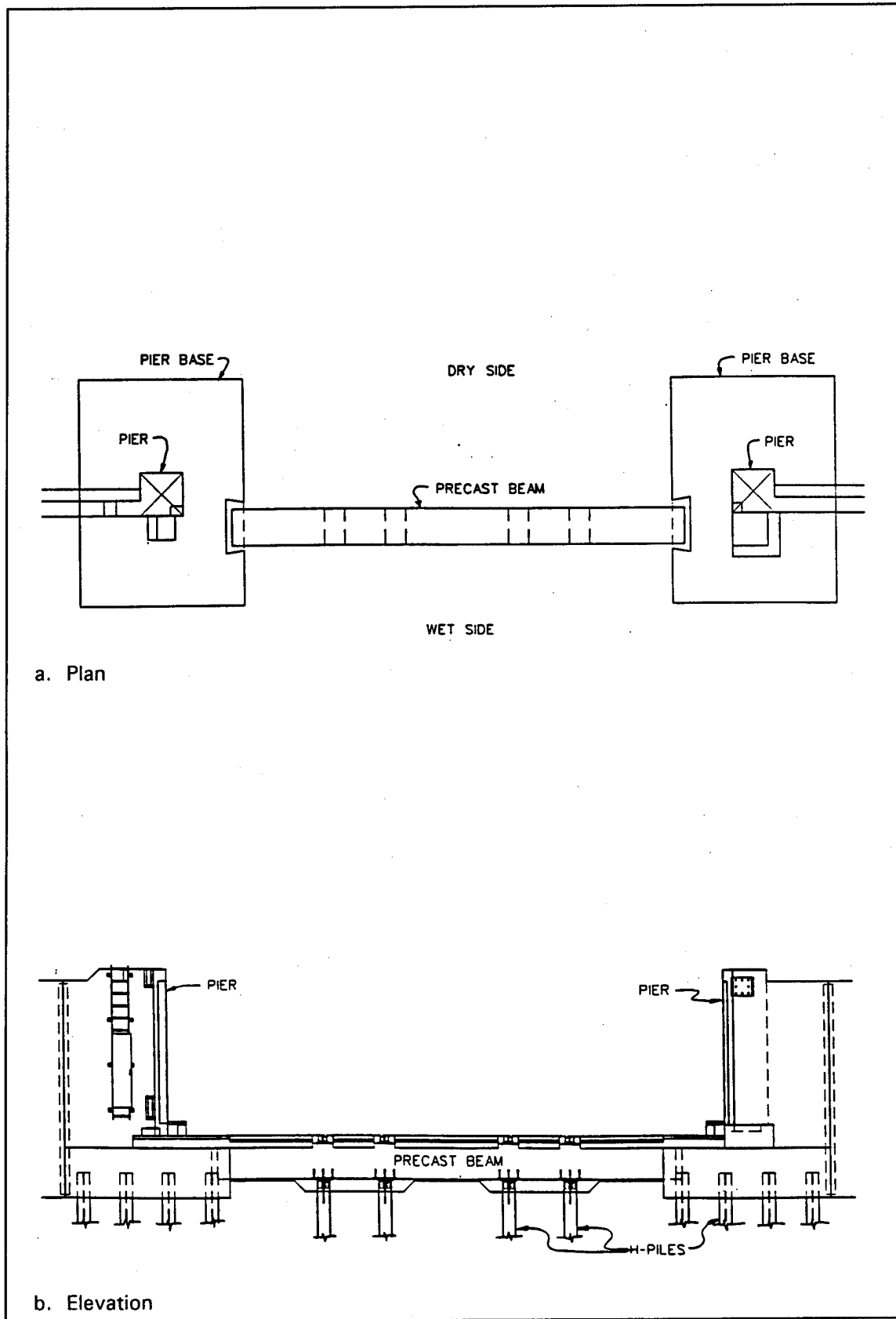

Figure 112. Closure structure, Pineville Levee and Floodwall (from Gunnels 1991)

Steel sheetpiling was driven parallel to the tracks to retain the material beneath the tracks during excavation for the pier bases. While the pier bases, piers, floodwalls, sheet-pile cutoffs, and H-pile supports were being constructed outside the sheet-pile containment, the railroad crew fabricated removable rail sections for each track and adjusted tie spacings to accommodate pile driving. These sections were removed to allow for construction beneath the tracks and replaced to keep trains on schedule. Working in 2- to 3-hr time periods between trains, the contractor was able to drive a sheet-pile cutoff perpendicular to the tracks and to drive the H-pile supports under each track. To allow time for installation of the precast-concrete sill beam, the railroad rescheduled some trains, and the construction crew worked on a holiday. This effort provided approximately 18 hr of uninterrupted construction time.

The first step in the installation was to excavate the area around the H-piles and trim and fit them with load-bearing caps. The cutoff-wall sheet piles, also exposed by the excavation, were fitted with studs to tie them to the sill-beam assembly. Next, quick-setting mortar was placed in the bottom of the excavation to the level of the interface between the pile cap and the sill beam. The sill beam was lowered onto the pile caps. Cast-in-place concrete was used to backfill around the sill beam (Figure 113). Hot tar was poured on the concrete between the sill beam and the sheetpiling to form a water barrier. Compacted ballast was used to fill the rest of the excavation to ground level.

The final step was to install the seal plate assembly and the deflector plates (Figure 114). Threaded studs were welded to plates which were cast in the top of the beams. The seal plate, a T-section with clip angles, was placed on the studs; adjusting nuts were used to match the seal plate to the bottom seal of the gate, which had been hung earlier. Then concrete was placed around the entire assembly, and extruded rubber blocks were fitted against the rails to form a water barrier. Once installation was complete, deflector plates, which would protect the sill beam from anything hanging from or being dragged by trains, were installed. The installation went so smoothly that the contractor finished the entire operation (Figure 115) with more than 7 hr remaining before the next train was due.

This innovative design allowed the closure structures to be constructed without disrupting railroad operations. It also eliminated the extensive work and expense required to construct a run-around. As a result of the success of this project, a similar design with precast concrete sill beams was used for the protective works at Harlan, KY. Also, a modified version of the design is currently being used at Barbourville, KY.

Chouteau Island Levee

Chouteau Island separates the Mississippi River and the Chain of Rocks Canal just upstream of Lock and Dam No. 27 at Granite City, IL. During the October 1986 flood of the Mississippi River, it became apparent that it would be necessary to relocate a portion of the existing levee on Chouteau Island.

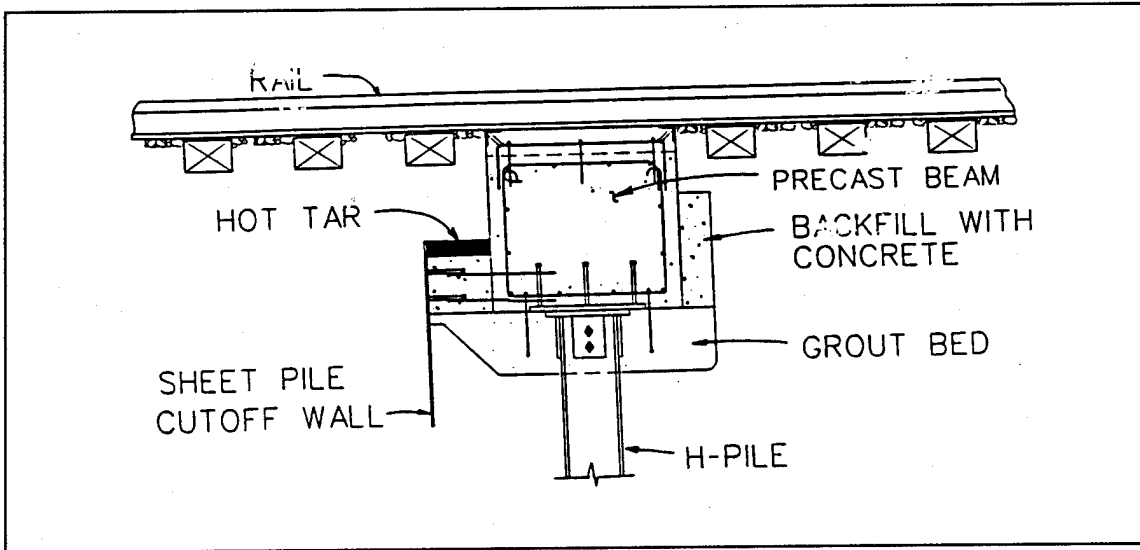

Figure 113. Cross section showing sill beam installation, Pineville Levee and Floodwall (from Gunnels 1991)

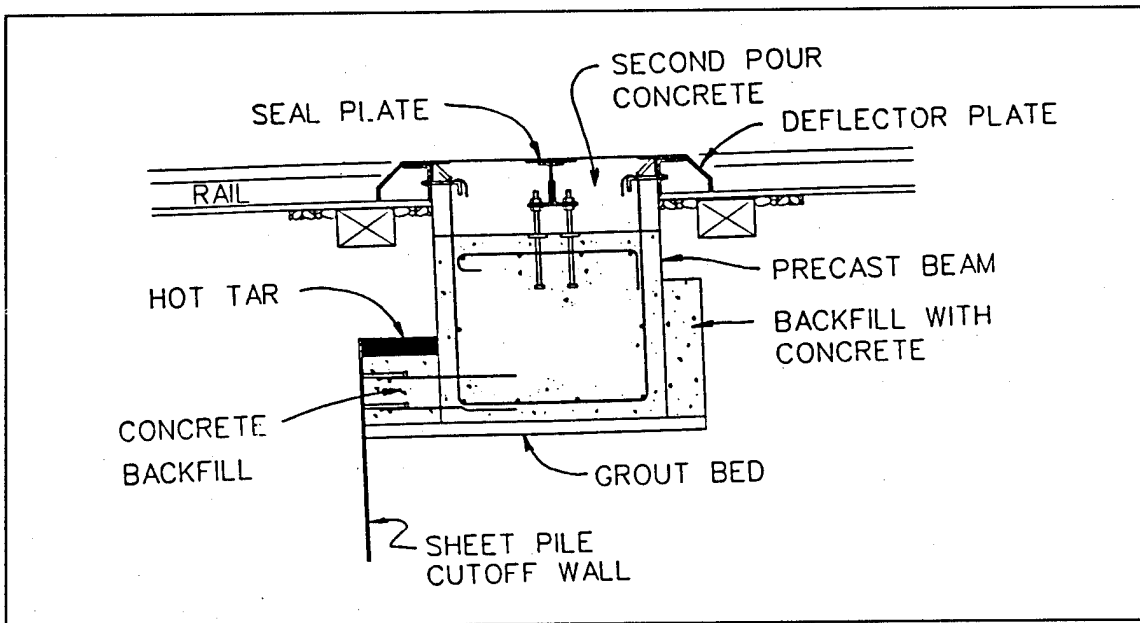

Figure 114. Seal and deflector plate details, Pineville Levee and Floodwall (from Gunnels 1991)

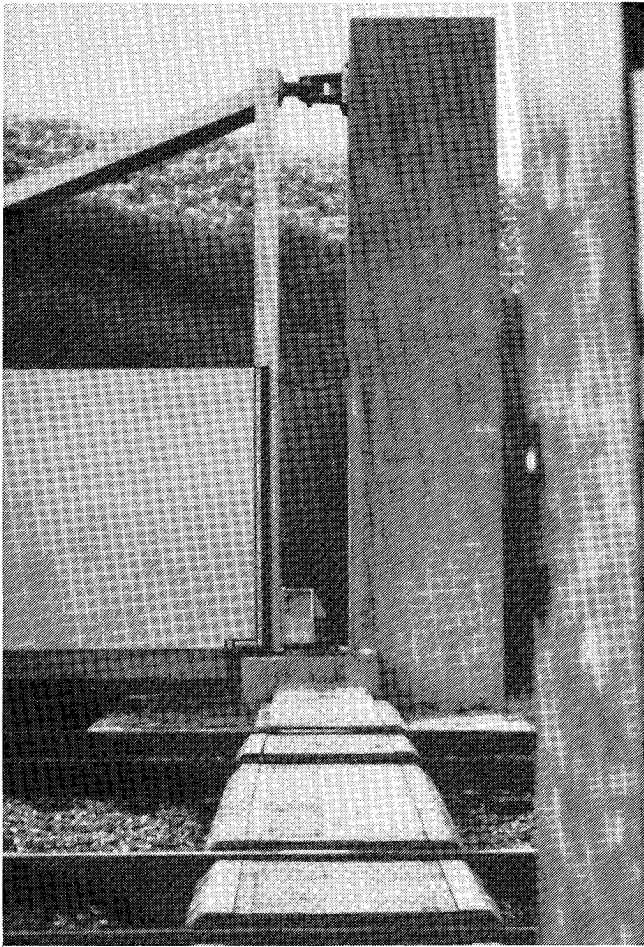

Figure 115. Completed closure structure, Pineville Levee and Floodwall

The new section of levee required a gravity drainage structure with a concrete gatewell and a relatively short gravity drainage pipe. Atchley (1989) described the project in detail; her report is summarized here.

Most drainage structures within the St. Louis District consist of bituminous-coated, corrugated-metal pipe (for drainage through the levee), and a concrete gatewell (a manhole which houses a sluice gate). During periods of low flow, the gate remains open to allow gravity drainage of the protected side of the levee. During flood conditions, the gate is closed to prevent back-water flow through the pipe and into the protected area.

These structures were built by the Corps and then became the property of the local levee district. Because the local district has limited funding, it needs structures that are as maintenance free as possible.

The original design of the Chouteau Island gatewell was based on cast-in-place concrete with a compressive strength of 3,000 psi at 28 days; however, the contractor submitted for approval a precast, two-section gatewell with the

same dimensions and reinforcement as the original structure. The precast plan was approved.

The contractor elected to use a concrete mixture with a higher cement content and a high-range-water-reducing admixture. The mixture yielded a 6-day compressive strength of 4,650 psi and a 14-day strength of 5,235 psi for the base placement and a 7-day strength of 4,420 psi for the wall placement. The higher early strengths were desired to allow rated removal of forms. If the higher strength had been considered in design of the structure, the wall thickness or reinforcement required could have been reduced accordingly.

Preassembling attachments at the precast yard, including the gate, ladders, guardrails, grating, and stoplog angles, provided an opportunity for problem correction before delivery. Also, the field team was able to have a "practice" installation before performing the field installation (Figure 116).

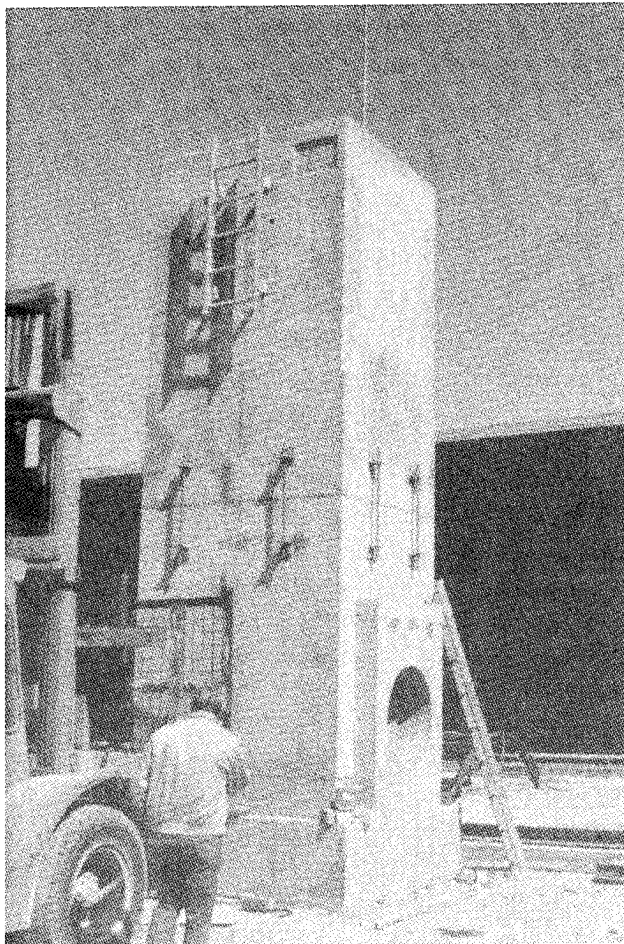

Figure 116. Two-section gatewell, preassembled at precast yard, Chouteau Island Levee (from Atchley 1989)

The structure was separated into its two components for shipping. Attachments that spanned the joint in the gateway and pieces that could be easily damaged during travel were removed for shipment. Since the compatibility of the various components was demonstrated prior to delivery onsite, field installation was greatly facilitated.

Coastal and Offshore Structures

Erosion is a major coastal and marine problem. Precast concrete modules, such as STA-PODs, Beachcones, Beachsavers, and Beach Beam, are being used not only to prevent erosion but, in some cases, to reclaim beaches. Precast concrete berms, wave deflector units, and seawalls are providing protection against high surf and tides in coastal areas. In addition, precast concrete modules are being used as underwater reef structures to attract fish populations and stimulate the growth of coral. At Poole Bay, the United Kingdom, these artificial structures are being cast of a mixture of waste products from coal-fired power plants and cement. Precast concrete components were used in the construction of a floating breakwater, smelt raceways, and a permanent cofferdam and in the rehabilitation of a lighthouse.

Fire Island Armor System

A number of concrete armor systems have been developed to prevent erosion along bodies of water. These units are especially effective in areas of high intensity wave action and high stone costs.

A single line of interlocking STA-PODs were used to construct a groin to help stabilize the beach at Fire Island, New York (Figure 117). One hundred 2-ton units and fifty 5-ton units were used in the structure.

STA-POD is a proprietary precast concrete unit that has been successfully used in a number of applications: erosion control, beach stabilization, and scour prevention. Each unit consists of a main trunk section and four stabilizing legs. The stabilizing legs are longer than the trunk section, allowing them to sink into sand or bottom material or be surrounded with rock material for greater stability. STA-PODS are cast in sizes that weigh from 1 to 40 tons.

Because there were no hydraulic or structural research data on the units, other than the performance of existing structures, the sponsors asked that WES conduct tests on selected STA-POD structures under certain hydraulic conditions. Tests were conducted to investigate the stability of STA-PODS in selected groin-type areas, in the surf zone, and on breakwater slopes.

The results of surf zone tests indicate that a 5-ton prototype unit with its stabilizing legs sunk into the sand will be stable for wave heights somewhat higher than 7.5 ft. The breakwater stability tests were inconclusive because there was not a sufficient number of units to construct an entire model



Figure 117. STA-PODS being used to help stabilize beach at Fire Island, New York (courtesy of Marine Modules, Inc., location of marine modules)

breakwater. Indications were that the armor units would be practical if they could withstand forces produced by construction and storms (Davidson 1974).

Additional applications for STA-PODs are shown in Figure 118.

Skegness Shore Protection

The 14-mile stretch of coastline between Skegness and Mablethorpe is the most exposed area on the Lincolnshire, England, coastline. Following severe flooding in 1953 that resulted in loss of life and numerous breaches in the coastline defense, National Rivers Authority (NRA) began a rehabilitation program for the area. By the 1980s, those efforts were beginning to show signs of decay. With the allocation of extra funds in 1986, remedial plans were expanded.

Rehabilitation of the sea defenses at Skegness included construction of a main sloping wall and two wave walls. The wave walls, topped by apron slabs, prevent overtopping, which could undermine the wall from behind, and provide a public amenity. The 1:3 slope consists of a concrete base, 1- to 3-ton rock, and 8-1/2 rows of Seabees, hexagonal, nut-shaped precast concrete blocks (Figure 119). This type of defense was selected as being in accordance with NRA's plan to use defenses that absorb energy rather than those that reflect it. Construction of the slope began with the installation of 16.4-ft-long piles along the toe of the wall. Toe and top beams were then installed to serve as a form for the concrete base and to keep the Seabees locked in place. Rock was placed on the concrete, and then the Seabees on top of the rock. Rock was also placed at the toe of the wall to prevent scour.

The purpose of the Seabees is to keep the rock from being washed away. Although the Seabees weigh less than the rock pieces, their shape allows them to be interlocked so that they stay in place. Also, at Skegness there was a short supply of rock and local objection to a rock wall, so Seabees became the logical choice.

The Seabees, each weighing approximately 1 ton, were cast onsite with concrete reinforced with polypropylene split fibers. Production rate was approximately 70 units per day, which was 50 percent better than the estimated rate. Because of the amount of excavation required in some places, the slope had to be completed in short lengths rather than operation-by-operation for the length of the beach.

Shell Island Erosion-Control System

Coastline erosion has been identified as one of the United States' most serious natural problems. An excessive loss of beach sand is being caused by a combination of winds, waves, tides, and the effect of low and high pressure weather systems. As a result of these phenomena, more sand is being lost in winter than is being built up in summer.

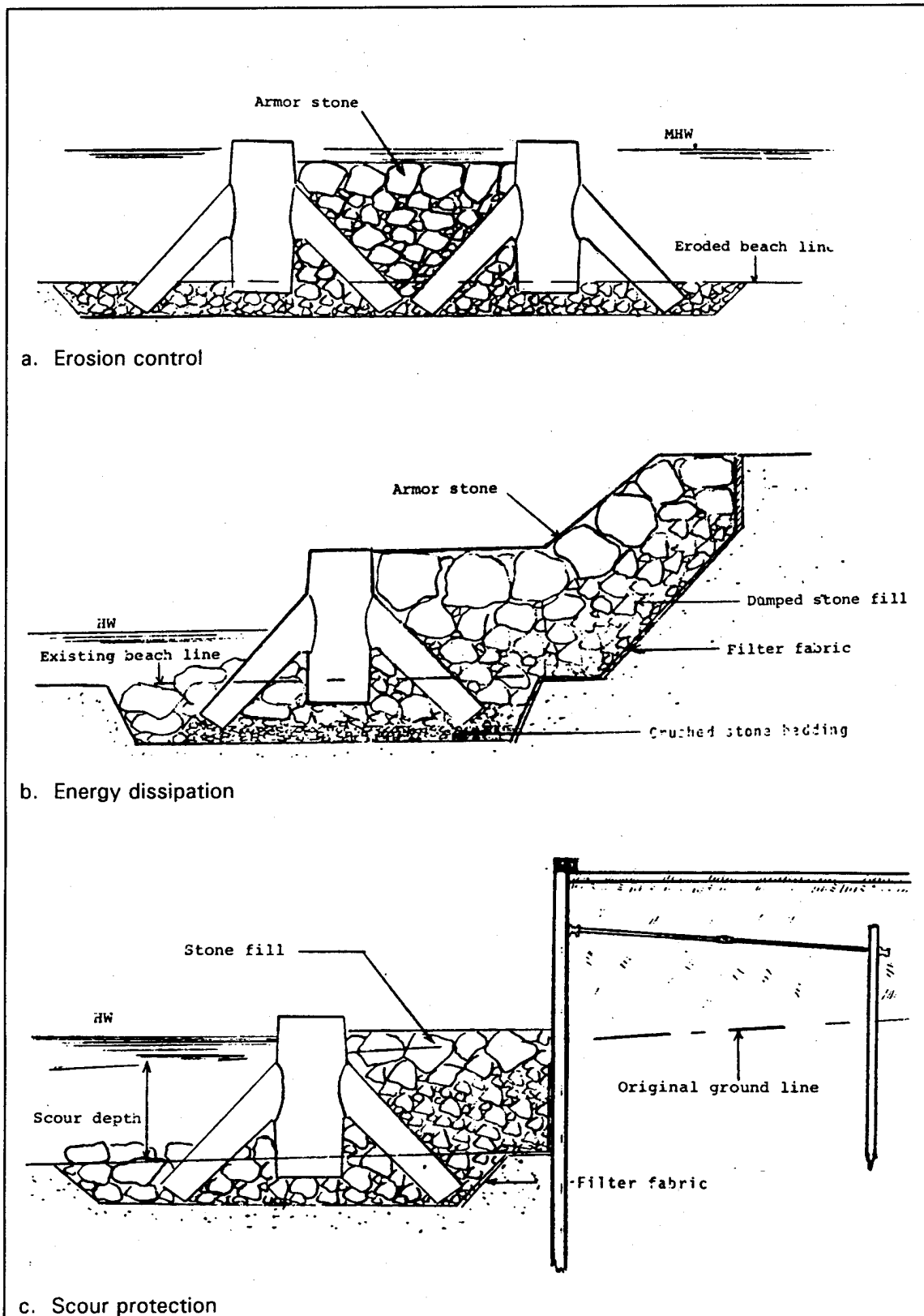

Figure 118. STA-POD armor system applications



Figure 119. Seabees being placed in an interlocking arrangement to prevent rock erosion on the sea defense slope at Skegness (from Slavid 1991)

The problem with many erosion-control structures is that in halting erosion in one area, they create it in another. For example, the effectiveness of jetties, barriers, and riprap as erosion-control structures is often undermined because of scouring caused by the structures themselves. A recently developed, precast concrete erosion-control system that does not cause scouring is being tested in Louisiana (Beachcone Research, Inc. 1992).

A Beachcone system consists of a number of Beachcones connected with Waveblocks. A Beachcone is a 6-in.-high unit shaped like a cone with an opening at both ends. The diameter of the top is about 24 in., and the diameter of the bottom is about 40 in. The walls of the unit are 1-1/8 in. thick. Each Beachcone weighs 92 lb and is precast with concrete with a compressive strength of 6,000 psi. The combination of Beachcones and Waveblocks slows down incoming waves and stabilizes accreted sand in a manner similar to the natural process by which underwater sandbars are formed, thus not only preventing loss of sand but also helping to rebuild shorelines.

Beachcones were first tested at Shell Island. Approximately 300 units were installed during July and early August 1992. When Hurricane Andrew swept through the area on 25 August 1992, the portion of Shell Island where Beachcones had been installed was not washed away; the island adjacent to the Beachcone installation washed away.

Beachcones are also being tested at Port Fourchon and Grande Isle, Louisiana's only inhabited barrier island. They have been installed at several locations in Alabama and Mississippi.

The smallest Beachcone system recommended is the "3-on-8." This system consists of 11 Beachcones and 12 Waveblocks arranged in two layers. These units are placed far enough out into the water that the tops of the Beachcones are barely covered at normal low tide. The units can be placed parallel to the beach or on a slight angle. Other combinations include the 5-on-12 double pyramid and the 5-on-12-on-21 tripple pyramid (Figure 120). In some cases, Beachcones are arranged singly in a zig-zag pattern along the shoreline (Figure 121). This arrangement has produced almost immediate sand accretion.

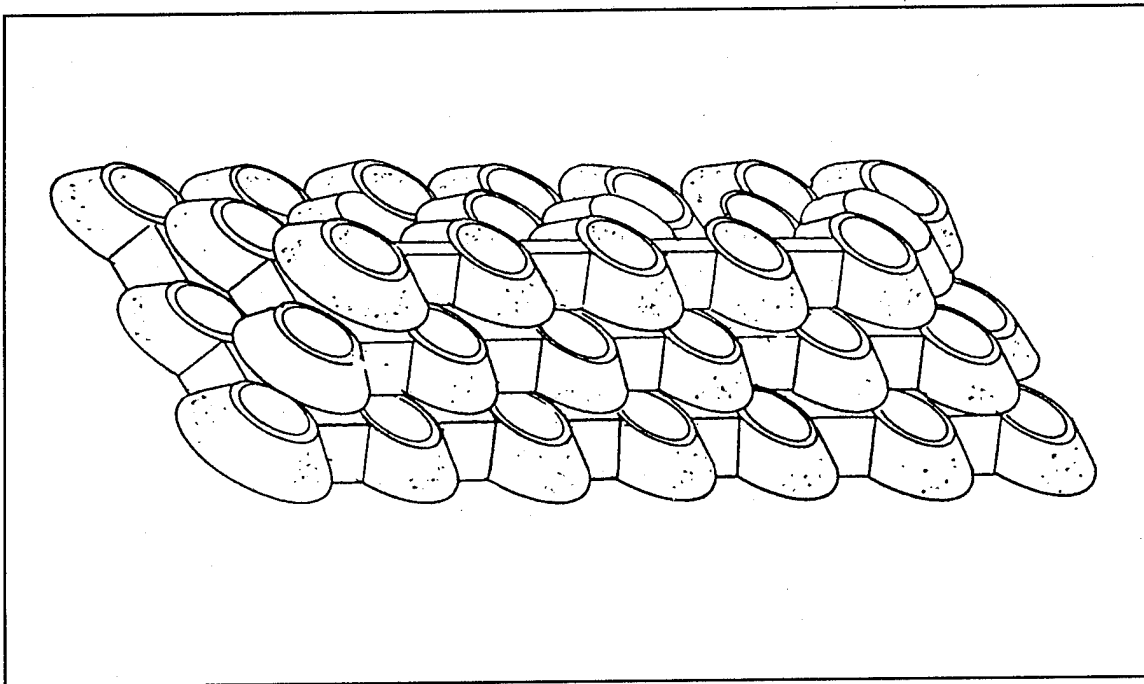

Figure 120. Beachcones arranged in triple pyramid (from Beachcones Research, Inc. 1992)

Cost of a Beachcone system ranges from \$50 to \$100 per ft of shoreline (1992 costs). When compared to the cost of pumping in sand or of building bulkheads or seawalls, Beachcones are cost effective.

Wallops Island Breakwater System

A Beach Beam, developed by Advanced Erosion Control of Queensland, MD, is a precast concrete structure designed to diminish wave energy before it reaches a soft shoreline and to help prevent erosion caused by ships' wakes, storms, and hurricanes. The structure has a concave surface with openings that allow water with sand and sediment to flow through it. The concave

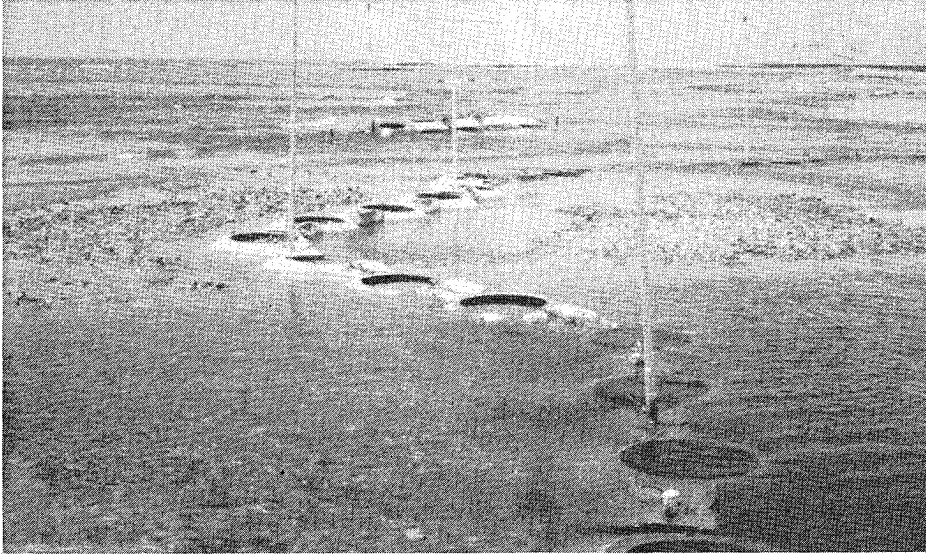

Figure 121. Beachcones placed at Shell Island (from Beachcones Research, Inc., 1992)

surface is designed to direct water upward, thus dissipating wave energy (Figure 122).

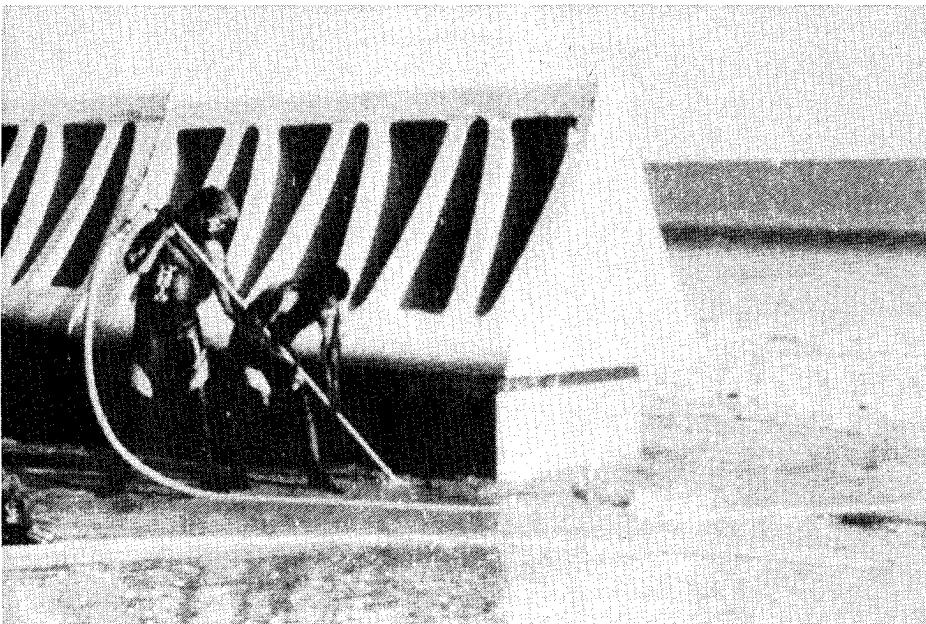

Figure 122. Beach Beam modules being installed for shoreline protection (from *Concrete Products* 1993)

Beach Beams have been installed on Wallaps Island, VA, for testing. The National Aeronautics and Space Administration (NASA) reported a 4-ft accumulation of sand behind the structures and no adverse effects on downdrift beaches. They have been used successfully at nine locations in the Chesapeake Bay area and the Inland Waterway in Florida.

Advanced Erosion Control has also developed bulkhead and barrier beams for shore protection. These structures, like the Beach Beam, direct water energy upward and into the structures. They can replace bulkheads, groins, and revetment systems and can be moved if necessary. They have been particularly effective in providing protection for bluffs (*Concrete Products* 1993).

Avalon Beaches

In many areas, beach erosion has become an economic problem because of beachfront development and tourism. Communities affected by this problem need methods that are effective and financially feasible for halting the erosion and reclaiming the beaches.

A precast concrete reef tested at Sea Isle City, NJ, may prove capable of meeting both requirements. The man-made reefs, which are manufactured by Breakwaters International, were donated and installed by the company for this test. Dr. Robert M. Sorenson of the Imbt Hydraulics Laboratory, Lehigh University, was in charge of the project. He was assisted by Dr. J. Richard Weggel of Drexel University and graduate students from both universities. The New Jersey Shore Foundation contributed a \$29,000-grant. The New Jersey Department of Environmental Protection and the U.S. Army Corps of Engineers approved the testing. The study is described in *Public Works* (1991).

Because Beachsaver reefs are exposed to a harsh maritime environment as well as cycles of freezing and thawing, they are cast with concrete with Microsilica Force 10,000. Microsilica can increase the compressive strength of regular concrete to approximately 8,000 psi; impact strength becomes 10 times greater, and salt resistance 20 times greater. Precasting the units increases uniformity in size and shape, which in turn improves installation.

Beachsaver reefs consist of an interlocking base and a top (Figure 123). The base is constructed with "feet," which help the system resist tidal forces. The top is designed so that it reduces scour by slowing wave action, which also encourages rebuilding of the beach. The depth at which the concrete reefs are placed helps determine the rate of rebuilding (Figure 124).

Data furnished by the Lehigh/Drexel study showed the beach elevation behind the reefs at Sea Isle City increased within a range of 1/2 to 1 ft in 9 months. By winter of 1991, the beach had built out approximately 40 ft along the shoreline behind the reefs; in some places, as much as 75 ft. Prior to installation of the precast reefs, the city had spent approximately \$1 million on pumping sand and building dunes.

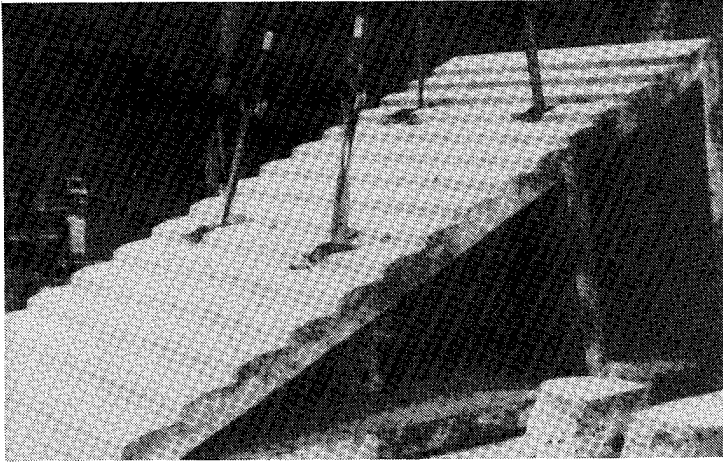

Figure 123. Typical precast concrete module used to create man-made reef (from *Public Works* 1991)

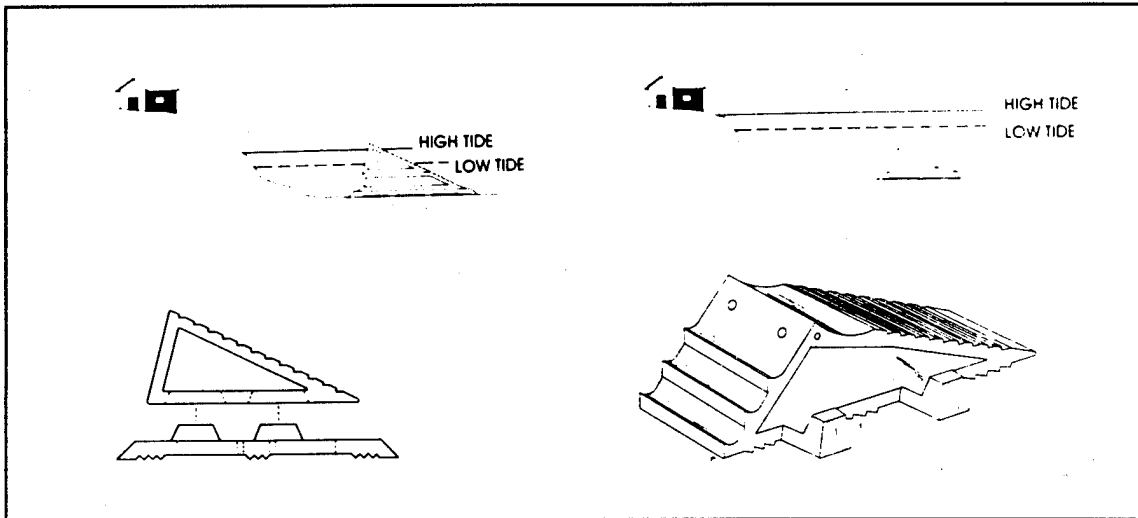

Figure 124. Structure and effects of placement of Beachsaver reefs (from *Public Works* 1991)

As a result of the success of the Beachsaver reef tested at Sea Isle, the state is sponsoring the Pilot Reef Project. Avalon Beach was the first site to receive a reef under the project.

The Beachsaver reef at Avalon is 1,000 ft long and is located about 250 ft offshore. Each unit in the artificial reef is 10 ft long, 15 ft wide, 6 ft high, and weighs 21 tons. The precast units were shipped to Avalon by barge. A crane on the barge was used to lower the units into 12 ft of water (Figure 125) where they were guided into place and locked together by divers (ASCE 1993).



Figure 125. Beachsaver reefs being placed at Avalon Beach (from ASCE 1993)

The artificial reef is expected to slow erosion of the shore area and to help protect beaches during storms. The triangular shape of the reef causes it to trap eroding sand and push it upward into waves that return it to the beach. A lip on top of each unit faces the shore and helps return sand to the beach. The ridged face of the reef dissipates up to 30 percent of the wave energy that strikes it, directing some sand to the reef's base and preventing scour (ASCE 1993).

Construction of the artificial reef at Avalon required 3 weeks and cost approximately \$750 per linear foot. The reef will be inspected every 3 months and after major storms by Davidson Laboratory from Hoboken. Reefs are to be placed off Cape May Point and at Belmar-Spring Lake as part of the Pilot Reef Project.

Sargent Beach, Revetment

Sargent Beach, Texas, is an area along the Gulf Intracoastal Waterway (GIWW) between East Matagorda Bay and Cedar Lakes. It is about 20 miles southwest of Freeport. The beach area is separated from the Gulf of Mexico by the GIWW and a land barrier that is in danger of being completely lost to erosion. The Galveston District has researched the problem and drafted a plan to combat the erosion. This case history is a summary of that report (Carver et al. 1993).

The GIWW is economically important as an efficient and economical means for transporting goods and freight. Waterborne Commerce data show that over 16 million tons of commerce was moved on the GIWW past the Sargent Beach area during the 1988 calendar year. This commerce was

transported between ports on the Texas coast and ports as far away as Pittsburgh, Chicago, Minneapolis, and Sioux City.

Along most of its length, the GIWW is protected from the wave action of the Gulf by barrier islands, peninsulas, and land cuts along major bay systems. However, in the Sargent Beach area the only protection is a narrow strip of land. If erosion of the land barrier continues at the present rate, the barrier will be breached, and the rough open waters of the Gulf will be admitted to the channel. Navigation will be greatly inhibited; the shoaling rate of the channel will increase; dredges will not be able to operate, and barge traffic will be halted.

The changing shoreline conditions in the Sargent Beach area have been mentioned in various reports since 1974. During that time, approximately 40 beach homes located between the Gulf of Mexico and the GIWW have been destroyed as a result of erosion, and the land barrier has become narrower. In 1989, when the Galveston District completed its reconnaissance study of the entire 423-mile Texas section of the GIWW, the width of the land barrier varied from 650 to 900 ft, except for one area which was less than 300 ft. The portion of the study dealing with the Sargent Beach area clearly indicated the need to proceed immediately with a feasibility study to analyze rehabilitation alternatives to assure continued navigational usage of the GIWW through the Sargent Beach area.

The feasibility study, which was completed in November 1991, was conducted under the management of the Galveston District of the U.S. Army Corps of Engineers. The Coastal Engineering Research Center (CERC), WES, provided significant input. Results of this study formed the basis for the selection of a rehabilitation plan.

The study determined that the primary causes of erosion in the Sargent Beach area are lack of sediment supplied to the littoral zone, storm waves, wave overwash, and concentration of wave energy. Of these, the most serious cause is the insufficient amount of sediment delivered to the area.

The plan selected to combat the erosion is a precast concrete-block revetment with two concrete sheet-pile wall segments. The structure, with the end flares, will be approximately 8 miles long. The first phase of the rehabilitation work will be to excavate the existing ground to a 10.5-ft elevation for placement of the slope and toe of the structure. Next, a 2-ft layer of 1/2-in. to 200-lb blanket stone will be placed along the 1V:2.5H slope. The stone will be covered with a layer of 3.5- by 4- by 6-ft precast concrete blocks (Figure 126). During storm events, the +7-ft-high structure will be overtopped, so the concrete blocks have been sized to keep the entire revetment stable under storm conditions. Only minor movement of the blocks is expected during such events.

The rock toe, which will extend from the base of the structure, will protect the revetment from scour and undermining. In addition, a splash apron, constructed by angling concrete blocks into the existing ground just landward of

the structure, will prevent scour of the backside of the structure during overtopping.

The revetment-like structure will be built in-the-dry so the toe can be properly installed and so there will be adequate quality control for the placement of the blanket and cover materials for the toe and slope. Also, building in-the-dry will be less expensive and will produce more controllable results than building in the surf zone. In addition, the effects of weather and wave conditions will be lessened, thus reducing the number of construction delays and the possibility of damage to partially completed sections of the structure.

Estimated construction costs based on September 1991 price levels are itemized below.

Item	Cost
Lands and damages	\$ 422,000
Relocations	132,000
Roads, railroads, and bridges	922,000
Breakwaters and seawalls	
Concrete-block revetment	40,972,000
Concrete sheet-pile wall	25,206,000
Planning, engineering, & design	3,054,000
Construction management	4,706,000

Total Project Cost	\$ 75,414,000

In addition to the construction cost, interest during construction is estimated to be \$10,374,000. Total average annual costs, consisting of interest and amortization (\$7,661,000) and operation and maintenance (\$849,000), is estimated to be \$8,510,000.

Design activities are ongoing; therefore, there could be some modifications to the plan described herein. Tank tests on the currently designed cross section are being performed by CERC. Results of these tests could reveal needed changes to concrete block dimensions, toe configuration and dimensions, or slope changes.

When completed, the concrete-block revetment and concrete sheet-pile walls will prevent further erosion, thus ensuring continued use of the GIWW along the Sargent Beach area. At the same time, they will protect property, land, and wetlands.

Pacifica Seawall

Precast concrete panels were used to repair a seawall damaged by a storm in Pacifica, CA. The system, developed by Stresswall International, Inc., consists of two precast components: an L-shaped tie-back and a wall panel. A tie-back consists of a vertical T-shaped front that rests on a base which is extended into backfill. Geotextile is used beneath the base to minimize loss of

fines from the backfill. Precast panels are placed between the tie-backs to complete a section of wall (Figure 127). The system requires no mechanical fasteners, making installation easier and eliminating corrosion problems (ASCE 1988).

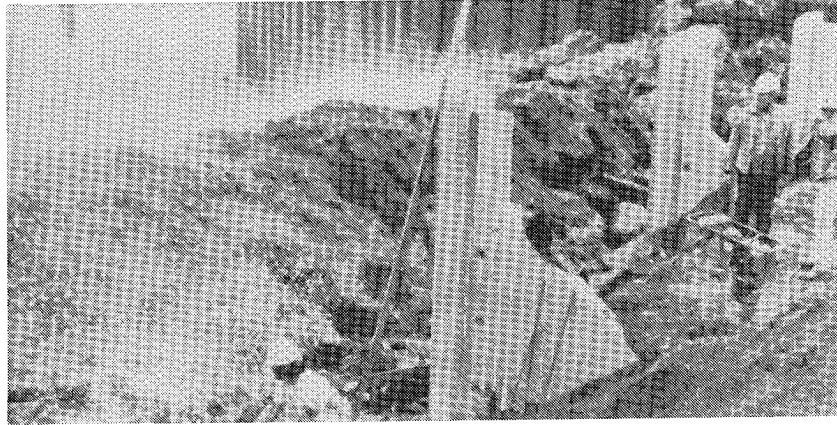

Figure 127. Precast tie-backs and panels used in seawall repair, California (from ASCE 1988)

The existing wall was 11 ft 6 in. high at the north end and 8 ft 6 in. high at the south end. This system allowed the contractor to build the wall to match the existing slope. Also, the surface of the panels was cast to match the existing wall.

A 3-ft-diam sewer line located behind the north end of the wall created a problem during installation. The sandy soil around the pipe could not be removed. Workers had to cut a trench and place the tie-backs and panels with a track hoe. Fill was placed behind the bottom panels and then brought to final fill height to create an area for the crane that placed the top panels.

Additional advantages offered by this precast system include quality control of the components, fast erection time, no requirement for any cast-in-place concrete, use of local backfill, and no special equipment needed for backfill compaction. Typical component costs for this system range from \$11 to \$14 per sq ft for material delivered to the job.¹

The seawall at Pacifica endured two more storms soon after installation. No damage was noted to the repaired area.

Cleveland Seawall

Inner Harbor Lagoon is the focal point for a large lake-front development in Cleveland, OH. A seawall was constructed to protect the site, created by

¹ Personal Communication, John Babcock, Stresswall International, Inc., Fort Collins, CO.

landfill in the 1930s (Zimmerman 1987). The original plan was to construct the seawall with tremie concrete because dewatering the jobsite was considered to be too difficult. However, the contractor preferred to use precast panels, which he planned to install in-the-dry. Realizing a dry installation would add approximately \$500,000 to the construction cost, the contractor devised a system to lower the groundwater enough to install the precast panels.

The panels, which were 12 ft high, 12 in. thick, and from 24 to 40 ft long, were precast at the site. All panels were braced with counterforts on 12-ft centers. Reinforcing steel for the counterforts was left exposed during precasting of the panels. To support the panels, pairs of steel H-frame piles were driven into the ground to form inverted "Vs"; the rear piles extended 5 ft higher than the front ones. A 17-ft stem and saddle extension allowed the front, compression piles to be driven about 10 ft and the rear piles about 5 ft below ground level. A template helped the crews maintain the correct batter.

After the piles were driven into the ground, a 14-ft-deep trench was dug around them to expose their tops and provide a work area. A 5-ft-long piece of wide-flange beam, called a "shoe," was welded horizontally to alternate piles to support the precast panels while the counterforts were cast.

After the panels were installed, reinforcing cages for the counterforts were slipped over the tops of the rear piles (a triangular piece cut from the tops of the piles made this step easier), prior to forming and placing concrete. Riprap was placed around the base of the 575-ft-long seawall to equalize water pressure between the two sides of the wall.

The contractor was able to construct the wall faster and more accurately with precast panels. Also, precasting improved the architectural finish on the front face of the panels.

River Tawe Quay

The quayside walls along the River Tawe near Swansea, a port city in SE Wales, were originally made of masonry. Over time the masonry in many sections of the walls had deteriorated, and the sections that remained were ready to collapse.

The Swansea City Council decided to use a geogrid, reinforced soil structure and full height precast concrete panels to rehabilitate the quayside walls. This method was calculated to be the most cost-effective. The rehabilitation is described in *The Dock and Harbour Authority* (1991) and is summarized here.

Short tails of the Tensar SR80 geogrid were embedded in the concrete panels during precasting. These tails were then attached to horizontal lengths of the geogrid with a needle joint. After the geogrids were tensioned, fill was placed on them and then compacted. The horizontal layers of the geogrid

give the wall structural stability. The precast concrete panels hold the fill and provide protection from waves and debris.

The construction method was compatible with the tidal river situation. The completed wall is an effective feature of the River Tawe Quays and Jetties project, a program to reclaim land and rejuvenate the former industrial shores of Swansea's main river (Figure 128).

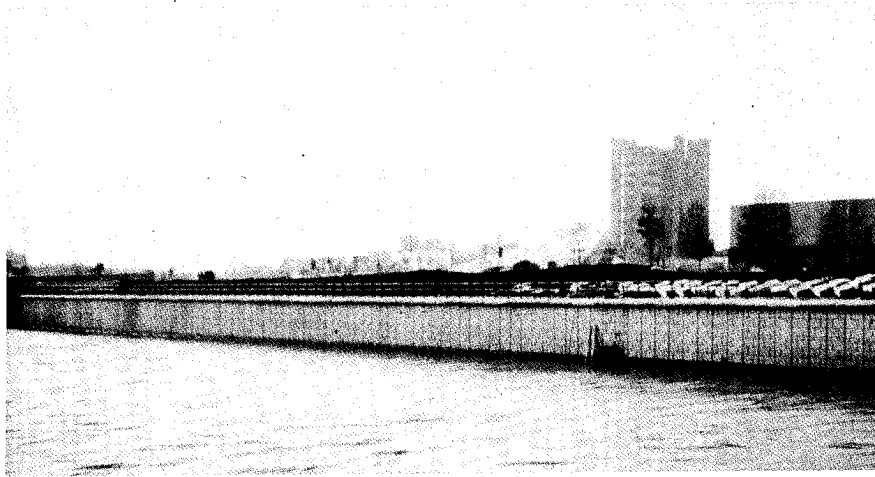

Figure 128. Rehabilitated Quayside Wall, River Tawe, Swansea (from *The Dock and Harbour Authority* 1991)

Indian Ocean Reefs

A 3-year study to determine the feasibility of using precast concrete artificial reef structures to promote reef recovery is being conducted in the Maldives, a chain of low-lying atolls in the Indian Ocean southwest of Sri Lanka (Edwards and Clark 1992).

Coral reefs are economically important to coastal communities not only as tourist attractions but also as sources for food, aquarium trade, building materials, and sea defense. However, because of destructive fishing techniques, coral mining, channel blasting, sewage pollution, and other man-made acts of destruction coupled with natural disturbances, such as hurricanes, coral diseases, and attacks by coral-eating fish, many of the reefs have been damaged to the extent that recovery may take several generations or may not occur at all.

When a living reef is mined, the top 1.6 ft of coral is stripped away with crowbars; what is left is a bare rubble reef (Figure 129). In North Male Atoll, submerged ring reefs, called "faroos," that were mined over 20 years ago have shown no signs of recovery. Galu Falhu, the reef area selected for this study, has been badly degraded by mining. This study, funded by the United Kingdom Overseas Development Administration, proposed to use

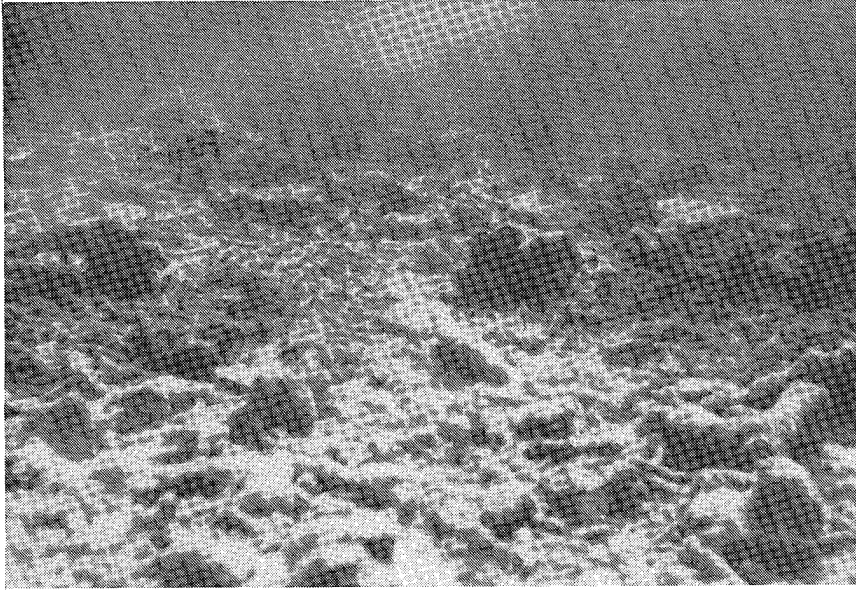

Figure 129. Remaining rubble of a previously mined coral reef, Indian Ocean (from Edwards and Clark 1992)

precast concrete structures to stabilize the substrate in the area of the damaged reef flats, to provide shelters that would attract the fish back onto the coral reef, and to stimulate the growth of corals in areas where they might not develop.

Three types of structures are being used in four areas of study: Shephard Hill Energy Dissipator (SHED) precast concrete blocks, Armorflex concrete mattresses, and chain-link fencing anchored with concrete paving slabs. To provide a valid measure of the effectiveness of each of these structures, researchers have marked off replicate 60-sq yd areas for each structure and also control areas of degraded and healthy coral. The areas are being monitored by divers making visual inspections supported by underwater photography.

SHED blocks reduce water movement across the coral flat, and their hollow centers serve as shelters for fish (Figure 130). Some of the SHED units were modified with concrete infills and plastic drain pipes to reduce the size of the open areas, making them more attractive to smaller fish, and to provide more area for the settlement of corals and other benthic invertebrates.

Armorflex concrete mattresses are precast concrete cellular blocks linked by polyester cables (Figure 131). The individual cells and joints between the cells provide holes and crevices of various sizes for small reef fish as well as surfaces for settlement of organisms. The concrete mattresses are also being used in a separate area to provide a platform for transplanted corals to determine whether this method can be used to speed up recovery of fish populations and/or growth of coral (Figure 132). Chain-link fencing is being used to stabilize the loose rubble left when coral has been mined to determine whether the lack of recovery is the result of the rubble's being unconsolidated. The fencing is placed over the rubble and then anchored with concrete paving.

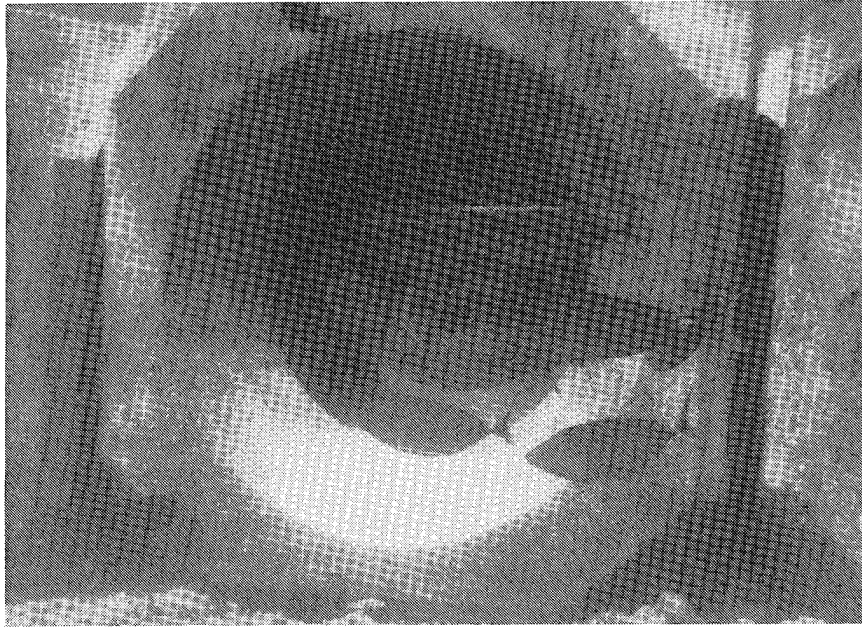

Figure 130. A SHED block, Indian Ocean (from Edwards and Clark 1992)

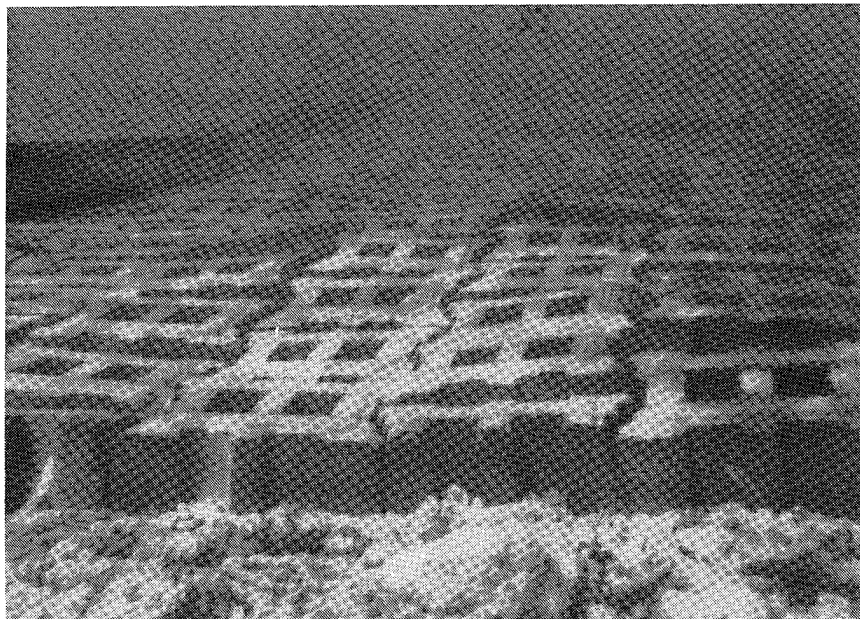

Figure 131. Precast concrete cellular mattress, Indian Ocean (from Edwards and Clark 1992)

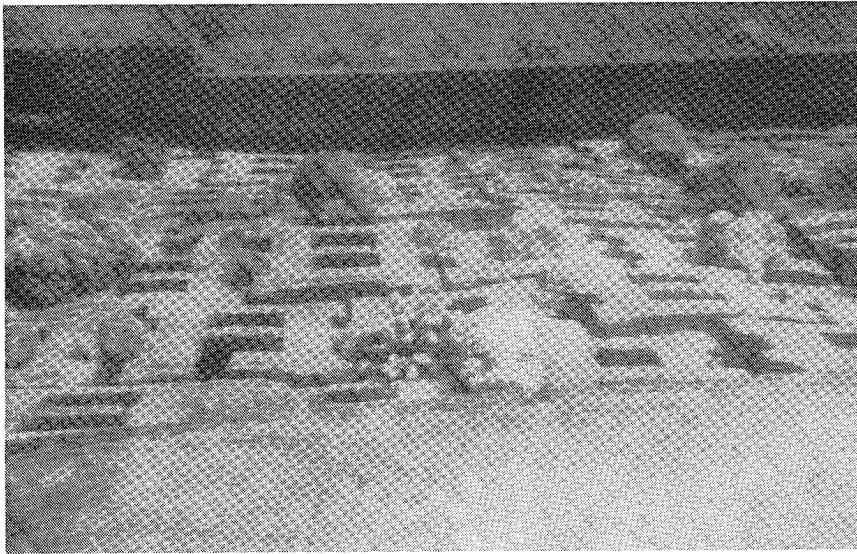

Figure 132. Cellular mattress with transplanted coral, Indian Ocean
(from Edwards and Clark 1992)

All of the structures were transported to the study sites by barge. They were placed by an excavator on a barge assisted by divers in the water.

Fish colonization of the structures began within hours after they were placed. The increase in variety and numbers of fish has been rapid as compared to that in the degraded control areas. After 10 months, no notable differences have been found in the average numbers of species inhabiting SHED blocks, bare Armorflex, and coral-transplanted Armorflex; they have almost reached their goal; however, the chain-link fencing has not been as successful. There has been an increase in fish population in this area over that in the degraded control areas, but the fencing is not proving to be an alternative for the natural coral environment. One theory concerning the lack of success of this structure is that it does not provide shelter.

After 6 to 8 weeks, most of the concrete surfaces were covered by benthic organisms: algae, bryozoans, sea quirts, hydroids, sponges, etc. However, the only concrete structures on which coral has begun to colonize are the SHED blocks. Ten months after placement of the blocks, two species of coral were identified. The survival rate and growth of these species are being monitored in an effort to determine those factors that are critical to the regeneration of corals. Indications are that coral colonization is more stable and rapid in areas that are above the abrasive action of sediments, approximately 1.6 ft above the seabed.

Even though the project is still in its early stages, it is considered successful (Figure 133). Information gained in this study will be used to develop guidelines for designing and placing precast concrete structures to foster the restoration of coral reef flats.

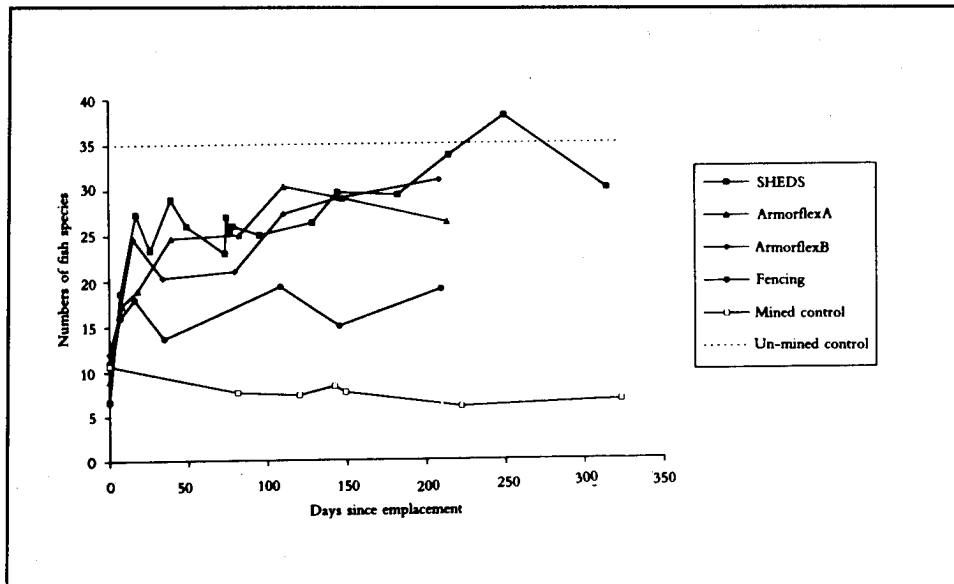

Figure 133. Results of inspections of the artificial structures and control areas, Indian Ocean (from Edwards and Clark 1992)

Poole Bay Reefs

Construction of artificial reefs with coal-fired power station waste products is being investigated in the United Kingdom (*The Dock and Harbour Authority* 1990). The waste materials are stabilized with cement to form blocks for the artificial reefs.

Waste materials being used include pulverized fuel ash (PFA) from the burning of coal, gypsum, and wastewater sludge from a flue gas desulphurization (FGD) plant (a facility that removes materials that contribute to acid rain). A concern is whether heavy metals (copper, zinc, lead, nickel) that remain in the ash and are also present in limestone will be released into the marine environment.

A similar investigation conducted by the United States indicated minimal loss of heavy metals from the blocks; however, the United Kingdom felt the necessity of doing its own studies because coals used in the United Kingdom differ from those used in the United States. First, test tiles made from the material were suspended in seawater for 6 months. Colonization of the tiles was rapid. Tests of the marine animals inhabiting the tiles indicated no transfer of trace heavy metals from the tiles to the animals. In the next test, planktonic algae were grown in seawater to which powdered block material had been added. Growth of the algae was normal. These studies indicated the reef blocks would not be detrimental to the marine environment nor the animals that lived in these environments.

Poole Bay, which has a sandy seabed, was selected as the site for the field study. The necessary permit for the artificial reef was obtained from the

Ministry of Agriculture, Food and Fisheries, and the blocks were cast at a commercial plant. Three different mixtures of PFA, gypsum, FGD sludge, cement, and gravel were used to make the blocks. Each block measured 100 by 50 by 100 in. and weighed about 70 lb. For comparison, the same size blocks were cast of standard concrete. Approximately 50 tons of blocks were cast at a commercial building block plant.

Members of a local commercial Fisherman's Association helped select the site for the reef. The blocks were placed 40 ft below the surface of the bay and arranged in two rows, each row containing a unit of blocks of each of the four mixtures. Each unit consisted of about 6 tons of block randomly stacked by divers in piles 3 ft high and 13 ft across. This random arrangement was selected to create spaces of various shapes and sizes to accommodate different species of fish and crabs.

Within an hour of placement, small shoaling fish collected around the blocks; within a month, marine organisms had begun to settle on the blocks. After 3 months, small red algae were growing on the upper surfaces. At present, 90 species of animals and plants have been identified on and around the reef. The reef blocks will be monitored for leaching of heavy metals, and the organisms living on and around the blocks will be analyzed for evidence of metal absorption.

Newbiggin-by-the-Sea Protection Structures

Located on the northeast coast of Great Britain, Newbiggin-by-the-Sea has always been subject to damaging storms that blow in from the North Sea. The sea comes in harder and faster in Newbiggin Bay because of the subsidence of the seabed, a result of underwater coal mining done in the area during the 19th century. Over the years, several different methods have been used to try to protect the area from the North Sea, but none has been permanently successful.

In a continuing effort to find a solution to the problem, consulting engineers developed a hypothesis for a 50-year storm in Newbiggin Bay by studying the patterns of wind, waves, and tides. They then designed a structure that would provide defense against the sea and protection for the coast during such a storm (Barfoot 1988). A scale model of the structure was tested in a hydraulic tank before actual construction was begun.

The 1,300-ft-long project consists of precast and cast-in-place reinforced-concrete berms placed in front of a deflector wave wall (Figure 134). Precast units were necessary for construction of the lower berms because of the tidal conditions under which they were installed. The berms rest on imported stone-rock fill, which was allowed 6 weeks for settlement before any structures were installed on top of it. A steel sheet-pile cutoff wall was constructed at the toe of the berms to keep the work from being undermined.

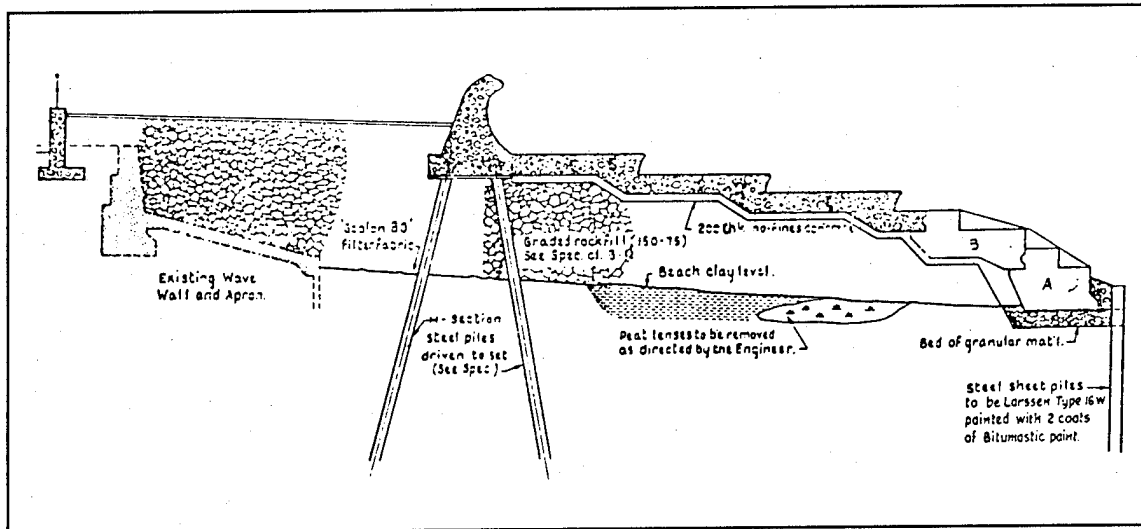

Figure 134. Cross section of sea-defense, coastal-protection structure at Newbiggin-by-the-Sea (from Barfoot 1988)

Concrete specifications for all construction included a compressive strength of 7,250 psi with a minimum cement content of about 673 lb/cu yd and a water/cement ratio kept low with the use of a plasticizer. All reinforcement had a minimum coverage of 4 in. Because of the high degree of accuracy demanded for alignment, construction was critical. The interlocking “male” and “female” units were prefabricated in four steel molds in a casting yard near the project (Figure 135).

A converted dump truck was used to transport the 13-ton units to the site, and a mobile crane was used to handle and place them. All work was accomplished between 8 A.M. and 8 P.M. as per the contract. During these hours, the maximum length of working time between tides was 4 hr; some days there were only 2 hr working time. Approximately 45 min was required to place a single unit (Figure 136).

Work on the project began in July 1987 and was expected to be completed in August. The contractor’s estimate for the project was about 48 weeks less than the designers’ estimate.

Clyde Quay Wave Deflector

Clyde Quay Boat Harbour at Wellington, New Zealand, has two breakwaters. The western breakwater was constructed between 1902 and 1903; the eastern breakwater, a year later. After 85 years, constant wave action had eroded the faces and was threatening the overall integrity of the structures.

In 1989, the Wellington Harbour Board decided to rehabilitate the breakwaters as part of its development of pleasure boat facilities. The project included increasing the overall height of the walls as protection against over

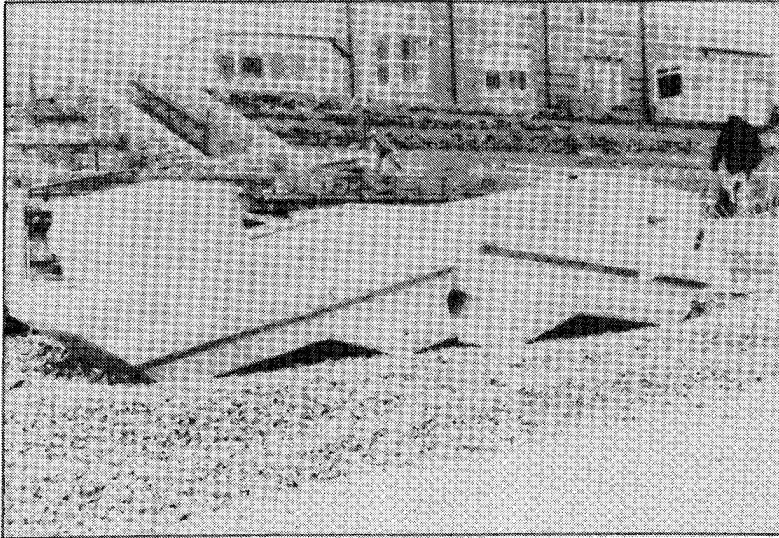

Figure 135. Precast units for lower berm, Newbiggin-by-the-Sea (from Barfoot 1988)

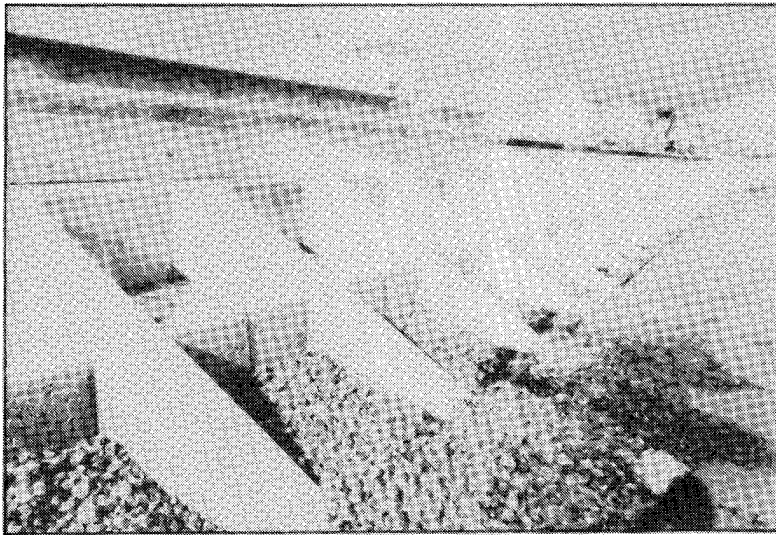

Figure 136. Completed section of lower berm, Newbiggin-by-the-Sea (from Barfoot 1988)

topping, resurfacing the eroded faces, and placing wave deflector units on the western breakwaters (*New Zealand Concrete Construction* 1991).

Cast-in-place concrete was used to form a cap along the breakwater to raise the overall height. Silica-fume shotcrete was the choice for resurfacing the faces of the breakwater. Sixty precast concrete units were used to form a wave deflector on the southern portion of the breakwater.

Because of the harsh exposure conditions, galvanized reinforcement was specified with a minimum cover of 2 in. Also, a minimum compressive strength of 4,500 psi was specified for the concrete.

The precast wave deflector units, each weighing 1-1/4 tons, were lifted by crane onto a trolley that straddled the concrete cap and then were hand-pushed to position. A chain-block crane was used to lift the units from the trolley and lower them over the installed anchors (Figure 137). All 60 precast units were placed with a high degree of accuracy in less than 3 days.



Figure 137. Precast wave deflector unit being placed by chain-block crane at Clyde Quay (from *New Zealand Concrete Construction* 1991)

Chaffers Marina Floating Breakwater

Chaffers Marina in New Zealand is located in an area that was formerly used by passenger liners; therefore, water depths were 30 to 40 ft. A marina breakwater was required to reduce wave action within the marina so

recreational boats could be berthed. A conventional rock-mound breakwater would have been too expensive because of the water depths; therefore, a number of alternative breakwater systems were investigated. These alternatives included a piled timber screen, floating rubber tires, and a variety of floating concrete structures. A prestressed, precast concrete floating breakwater was selected (*New Zealand Concrete Construction* Dec 1993-Jan 1994).

The design of the breakwaters was based on a 50-year northeast return period wave height of 5 ft. The original design was a series of precast, prestressed straight components, which would be posttensioned together either in the water or on a temporary slipway. However, the contractor elected to build a temporary dry dock to allow construction of the breakwater in three units, thus reducing the amount of posttensioning required in the water. The breakwater was cast as a series of "H"-shaped segments, with each segment being match-cast against completed segments. Each segment has a polystyrene core, which was enclosed in a reinforcing cage before being placed into the formwork. All reinforcing was galvanized steel with a minimum cover of 2 in. The concrete mixture for the breakwater had a compressive strength of approximately 7,500 psi with 3/4-in. maximum size aggregate and high-range-water reducing admixtures. The density of concrete is critical to buoyancy; density design of the concrete for the floating breakwater was 148 lb/cu ft. To make sure that the overall weight of the breakwater met specifications so it would float at the correct level, workers weighed concrete trucks before they entered and after they left the site, as well as excess concrete, reinforcing, and polystyrene.

When they were completed, the three units were moved into the water and then towed to the breakwater location (Figure 138). They were moored into position, and the units were posttensioned together. The 656-ft-long by 35-ft-wide breakwater was then anchored to seabed piles with chains attached at 23 locations on the longitudinal and cross members. The completed breakwater has reduced the wave climate within the marina to a level suitable for mooring recreational boats (Figure 139).

New Zealand Salmon Raceways

Salmon hatched at the Southern Ocean Salmon Farm near Takaka, New Zealand, spend their first months in concrete raceways before they are released into the sea. The original smelt raceways were constructed completely with cast-in-place concrete. However, the contractor elected to use precast prestressed concrete tilt slab panels in the latest extension work. The concrete in the precast slabs had a compressive strength of 6,000 psi. Costs of the tilt slabs was about what the formwork for cast-in-place concrete would have been. The extension project required 240 tilt slab panels (Figure 140). The bottom of the raceways was cast in place (*Concrete Construction*, Feb/Mar 94).

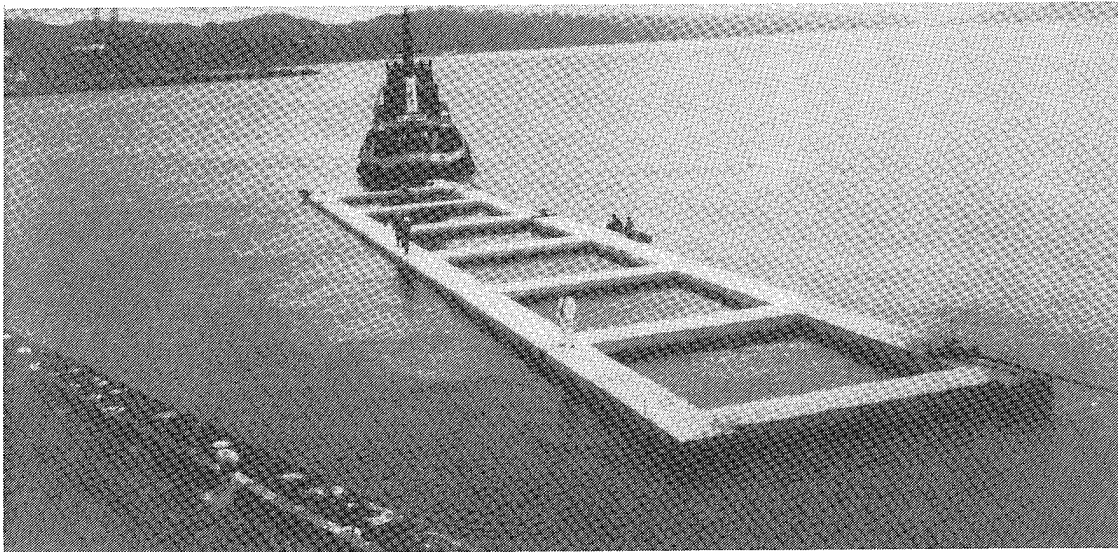

Figure 138. Precast concrete breakwater unit being towed to location at Chaffers Marina, New Zealand (from *New Zealand Concrete Construction* (1993-1994))

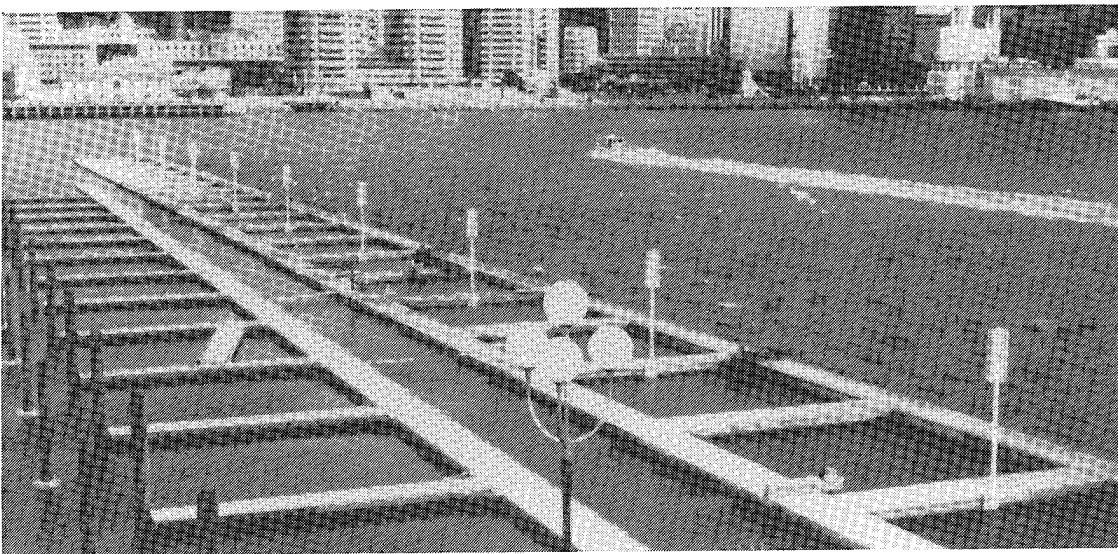

Figure 139. Completed precast concrete floating breakwater at Chaffers, New Zealand, (from *New Zealand Concrete Construction* (1993-1994))

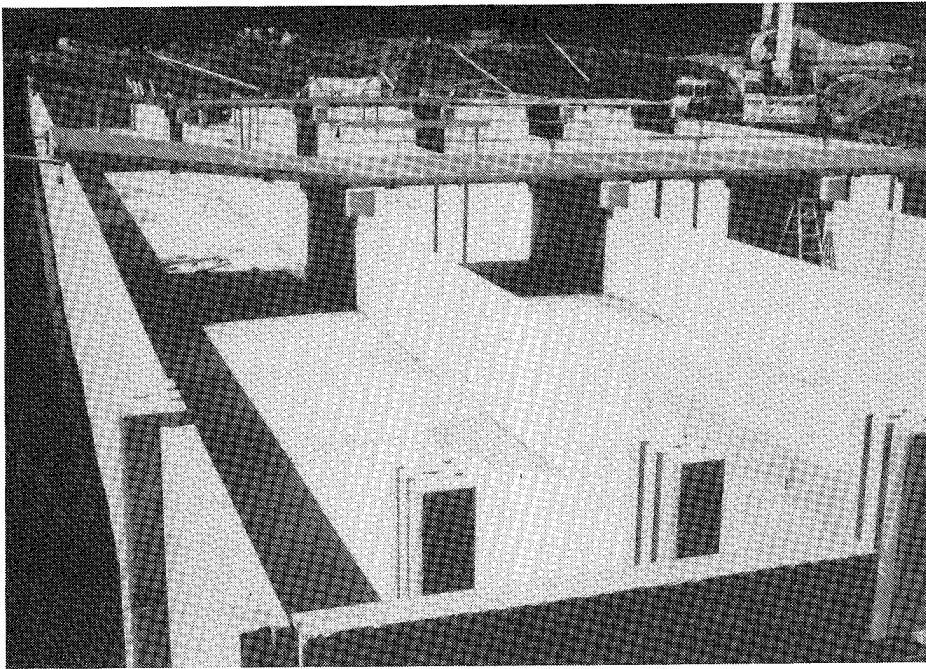

Figure 140. Smelt raceways at Southern Ocean Salmon. The walls are precast concrete tilt slabs (from *Concrete Construction* 1994)

Wallasey Cofferdam

As part of its effort to clean up the River Mersey near Wallasey, England, Northwest Water decided to use an interceptor sewer to collect flows from eight outfalls and carry them to a screening works, where major solids would be removed before the flows were discharged into the river. A pumping station was needed to carry flows to the head of the gravity section of the interceptor sewer. The site selected for the pumping station was an area of reclaimed foreshore. Locating the pumping station at this site required the construction of a permanent 230-ft cofferdam to protect the site from the sea (Barfoot 1987).

Placing a cofferdam at this location decreased the distance between the existing seawall and a breakwater that had been installed only 3 years earlier as part of a beach stabilization project. This reduction would increase wave energy, which in turn would increase the risk of scour and erosion damage; therefore, it was critical that the cofferdam be designed so that it would reduce reflected wave energy in the area.

The final design for the cofferdam was based upon a survey of published technical information, videos of the pumping station site during storms, and model tests performed in the Random Wave Flume at Liverpool University. The tests were a joint effort of the University of Liverpool, Ceemaid Ltd, of Hythe, Hants, and the Wirral Borough Council.

The cofferdam is constructed of individual precast concrete units, each consisting of two columns on the front, a base slab, top, and rear wall. Precast concrete was selected because it fit the requirements of a tidal construction site and the need for rapid construction of the cofferdam with concrete at full strength when installed. The units are joined so that the columns fall in an arrangement of two columns back and two forward (Figure 141). This arrangement destroys wave energy and reduces wave reflection considerably, but the effectiveness of the cofferdam depends upon the difference between incident waves and the fluctuating water level within the structure. To ensure that air would not be trapped beneath the soffits, they were fluted to direct air toward large vents formed in the top joints between units. The vents were covered with steel grills.

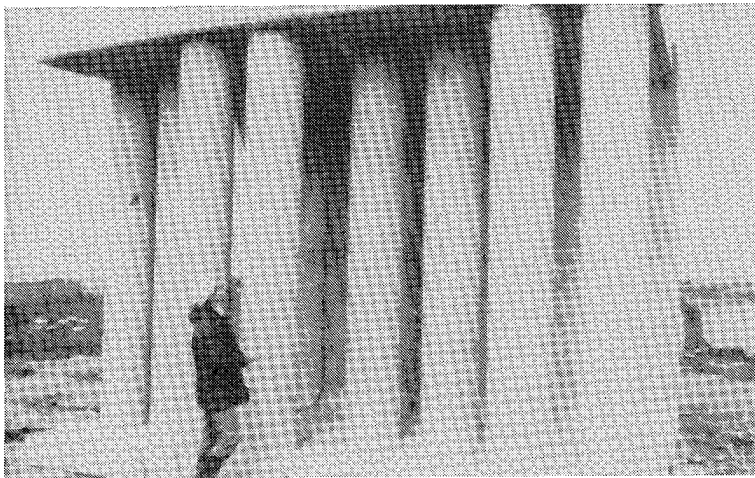

Figure 141. Four precast units showing arrangement of columns, Wallasey Cofferdam (from Barfoot 1987)

Concrete specifications called for a minimum cement content of 675 lb/cu ft maximum water-cement ratio of 0.4, compressive strength of 7,250 psi at 5 days, and basalt aggregate. A water-reducing admixture was used to obtain a slump of 2.5 in. plus or minus 1 in. within the specified water/cement ratio.

Steel molds were used for casting all components. The columns were cast separately ahead of the main units, which were cast on the side. Engineers felt side-casting was the best method for achieving accurate dimensions and well-compacted concrete and for reducing the risk of nonstructural cracking. The typical precasting sequence is shown in Figure 142. Once production was underway, a main unit was cast every day, and others were in some stage of construction. Individual units weighted a maximum of 22 tons. Forms were removed 24 hr after casting when the concrete compressive strengths were 2,200 to 2,900 psi. Compressive strengths were in excess of 5,800 psi at 40 hr when the components were lifted into storage.

Completed units were transported to the site on a flat wagon. An 80-ton capacity crawler crane was used to lift and position the units (Figure 143) on a

a. Molds for columns.

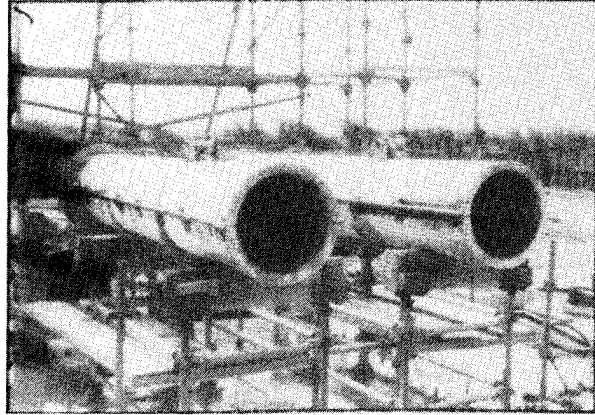

b. Columns set in with reinforcement of the main mold.

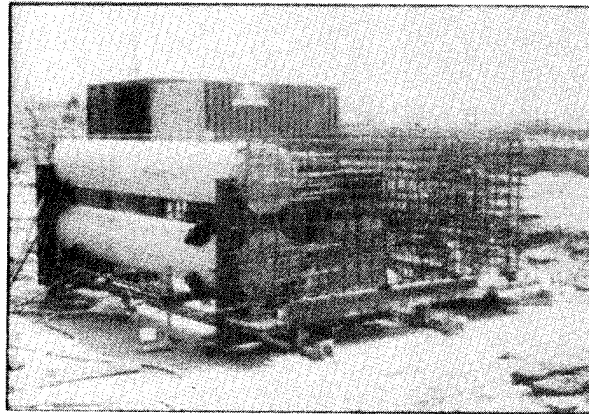

c. Side molds installed and unit ready for casting on its side.

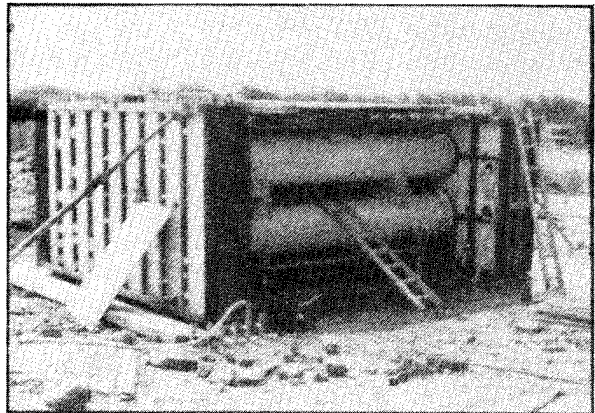

Figure 142. Precasting sequences, Wallasey Cofferdam (from Barfoot 1987)

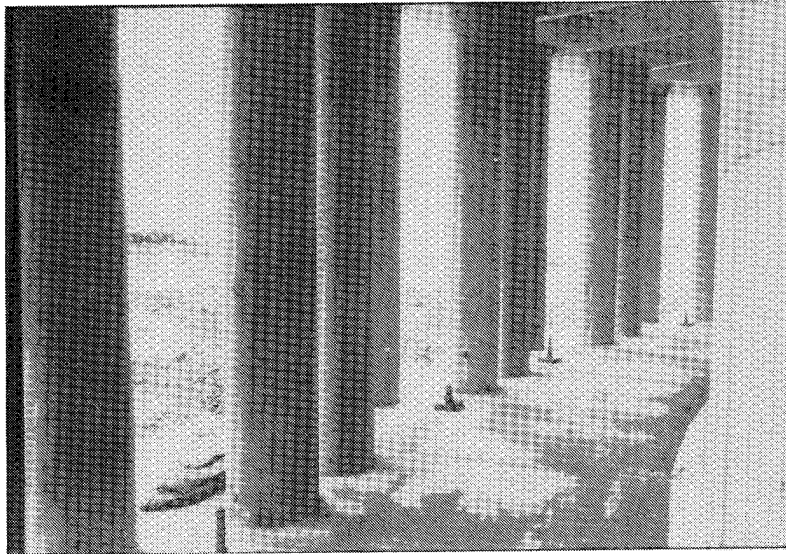

Figure 143. Erected units with lower joints grouted and temporary rock anchors installed, Wallasey Cofferdam (from Barfoot 1987)

8-in. concrete bed. Alternate units were anchored to the bedrock to provide stability for the cofferdam until backfill was placed. Lower joints were grouted; vertical and soffit joints were sealed on both sides with non-expanding grout and a preformed seal. In situ concrete was used to tie the ends of the cofferdam wall to the existing seawall. Once the cofferdam was completed (Figure 144), work on the pumping station began.

Brandywine Shoal Lighthouse

The historic Brandywine Shoal Lighthouse is located in Delaware Bay approximately 7 miles west of Cape May, NJ. Constructed between 1912 and 1914, the lighthouse is still operational but is no longer manned. The structure consists of a series of concentric concrete cylinders found on a 35-ft-diam precast concrete caisson. The entire structure rises about 80 ft above the mudline, about 65 ft above mean high water level. The harsh environment, age, and the loss of maintenance since the lighthouse had been automated all contributed to deterioration of the reinforced concrete structure.

In 1982, the U.S. Coast Guard initiated a contract to evaluate the condition of the lighthouse and design repairs to the structure. The study included visual inspection, chloride ion testing, compressive strength tests, and petrographic examination of core samples. The results indicated most of the deterioration had been caused by a combination of reinforcement corrosion and cycles of freezing and thawing of the concrete (Paul 1987). The worst areas of deterioration were in horizontal elements with exterior exposure, slender or fully-exposed exterior vertical elements, and areas with severe exposure such as the splash zone.

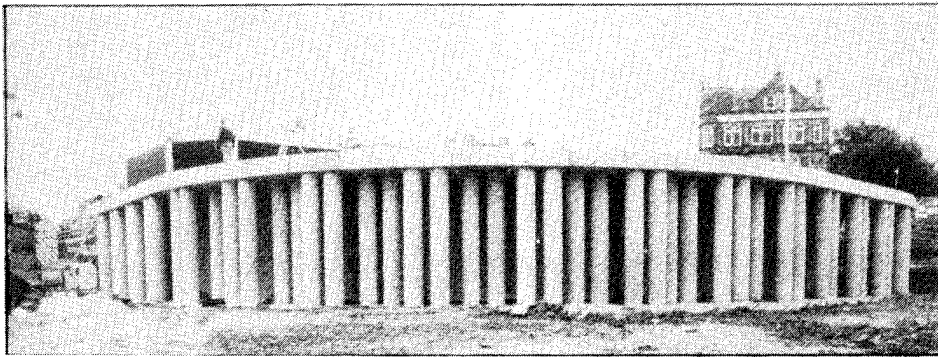

a. View from the sea side

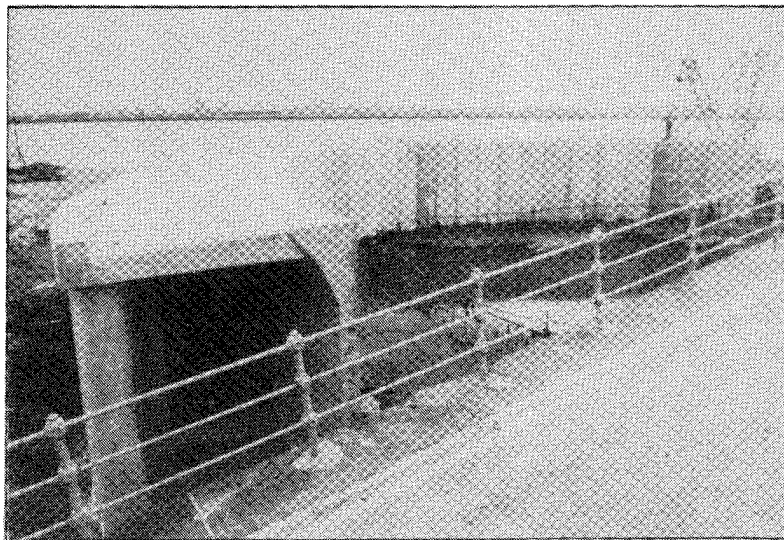

b. View from the landside showing area where pumping station will be constructed

Figure 144. Almost completed Wallasey Cofferdam (from Barfoot 1987)

Repairs were generally as shown in Figure 145. Precast architectural concrete was used to replace the first-level brackets and the column and the cornices of the veranda. Precast concrete was selected for several reasons: constructing these components in a precast plant allowed for better control of material properties and forming; better quality increased durability; and precast elements helped with staging and forming for construction that required support (Hurd 1988).

Specifications for precast concrete components called for a compressive strength of 5,000 psi with a maximum water-cement ratio of 0.44 and 7-percent entrained air. High-range water-reducing admixtures were allowed, but no chloride-containing admixtures were allowed. Reinforcing bars were epoxy coated, and metal embedments were either hot-dip galvanized or fabricated from stainless steel.

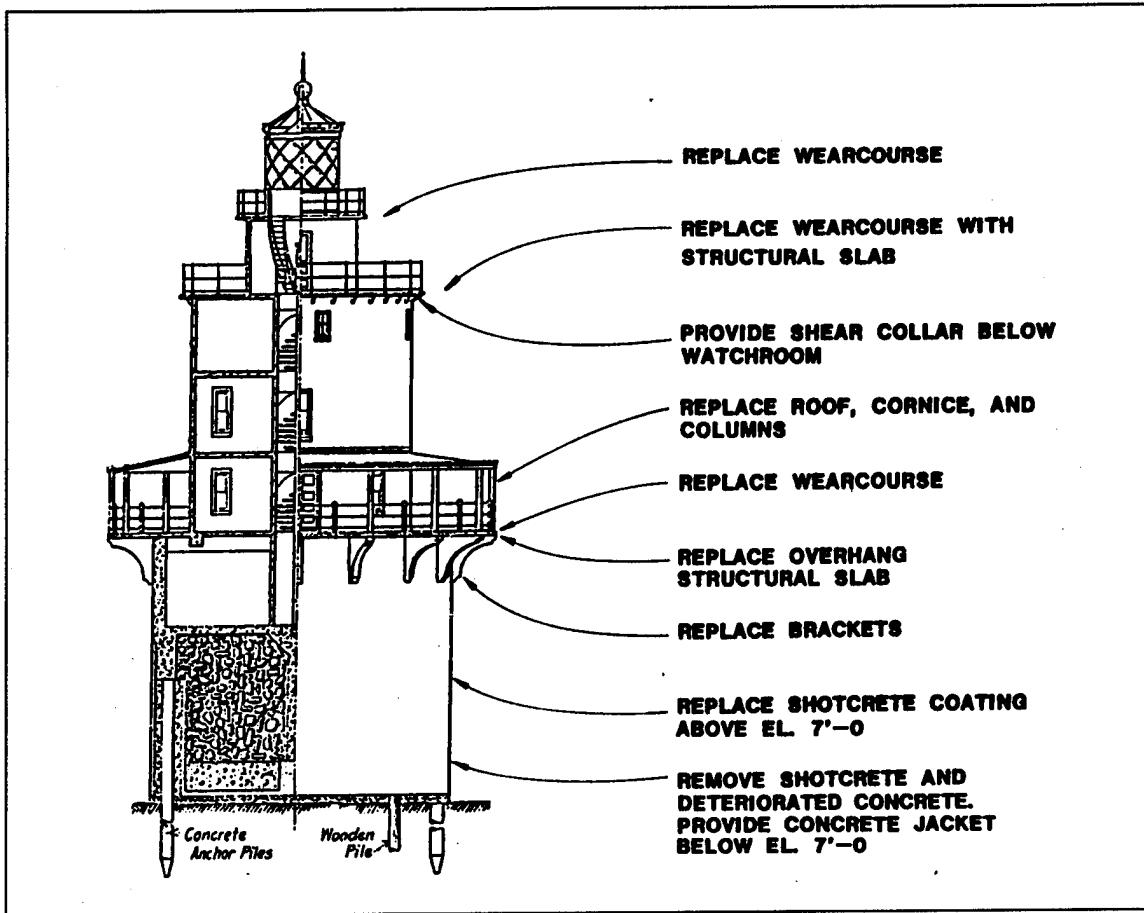

Figure 145. Brandywine Lighthouse repairs (from Paul 1987)

After the deteriorated brackets were removed, steel plates were bolted to the top of the caisson wall; embedded angles at the back of the precast brackets were welded to these plates, and the weldment covered with caisson concrete (Figure 146). Once in place, the brackets could immediately support the formwork and cast-in-place concrete for the overhanging deck replacement which would be cast-in-place. Brackets were attached to the veranda slab by stirrups that extended from the top of the brackets.

Once the slab for the veranda was completed, the precast columns were placed and welded to plates embedded above the brackets. Next, the precast cornice sections were placed between columns and welded to cap plates. This precast frame supported the formwork for the cast-in-place veranda roof.

After concrete work was completed, the entire structure was painted with high-intensity colors to provide the traditional day markings of the lighthouse. Repairs were completed in March 1987. Success of the project was recognized by the prestressed concrete institute with presentation of a special jury award in its 1987 Professional Design Awards Program (Hurd 1988).

Sydney Harbor

Precast concrete armor units, such as dolos, tribar, and tetrapod units, have been used in the construction of rubble-mound breakwaters and jetties. Precasting is also an expedient method of fabricating panels used in the construction of seawalls as evidenced by recent applications in Sydney Harbor (National Precast Concrete Association Australia 1991). At a development at Pulpit Point where the aesthetics of a proposed seawall were of a major concern, precast concrete seawall units were designed with a ledge which acted as a bearing surface for a sandstone veneer. The sandstone facing was used on the portion of the precast units that would be at or above the level of the adjacent boardwalk; a durable precast surface was exposed below to counter wave action and the destruction caused by seawater (Figure 147).

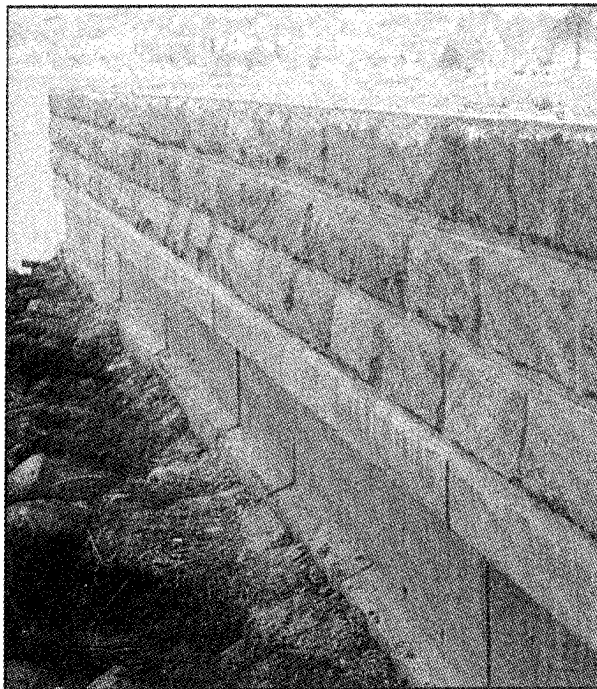

Figure 147. Seawall beyond line of boardwalk at Pulpit Point, Australia (from National Precast Concrete Association Australia 1991)

The choice of the sandstone facing stemmed from the developer's wish to mirror the widespread use of the stone in the surrounding heritage-conscious Hunters Hill. An alternative for enhancing the visual impact of such units is to use form liners (Figure 148).

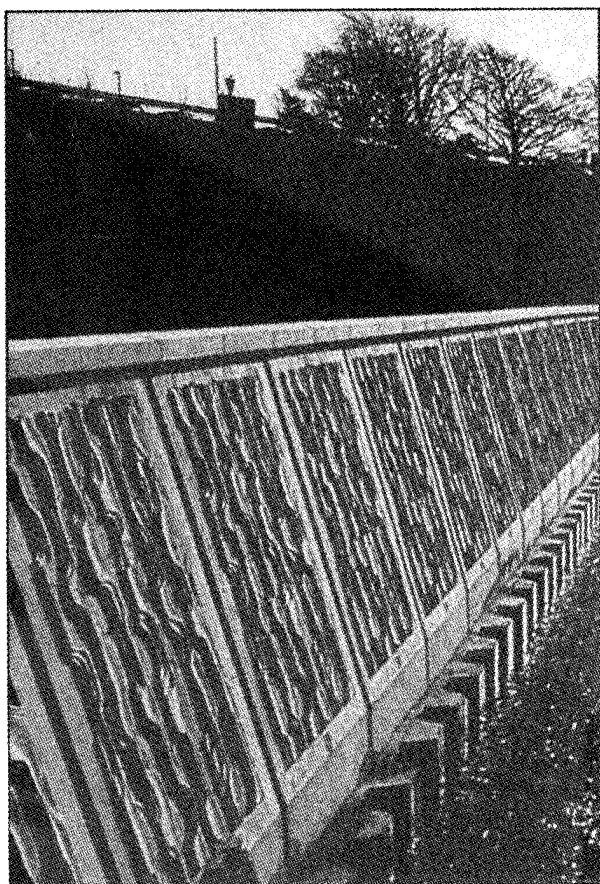

Figure 148. Use of form liner to create visual interest at face of panel-flood-protecting wall (from National Precast Concrete Association Australia 1991)

At nearby Birchgrove, a different requirement and design solution utilized some ninety 7-ton units (Figure 149). After placement, the void behind the parapet was backfilled.

This project was located in a residential area that has a very strong and influential residents' organization. Being able to have all concrete work completed offsite, thereby reducing noise at the site, and the markedly reduced clean-up were a bonus for the contractor.

Precast concrete is made more durable by the use of a generous cement content, using either Type A or a slag-blend cement and a low water-cement ratio, typically 0.35-0.4. Also, providing adequate cover for reinforcement (generally galvanized) and good compaction and curing increase the durability of a product.

The major advantage in the use of precast units is that they can generally be placed independent of tidal conditions and that a project can be completed without formwork, concrete placement, and stripping.

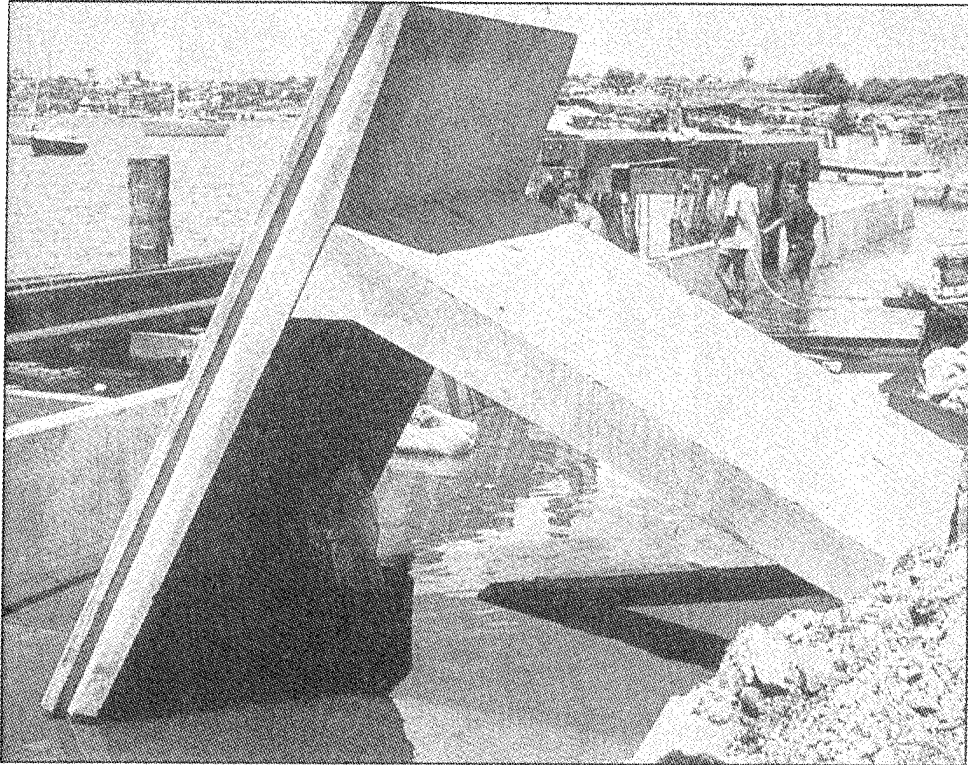

a. Precast concrete unit delivered adjacent to final placement position

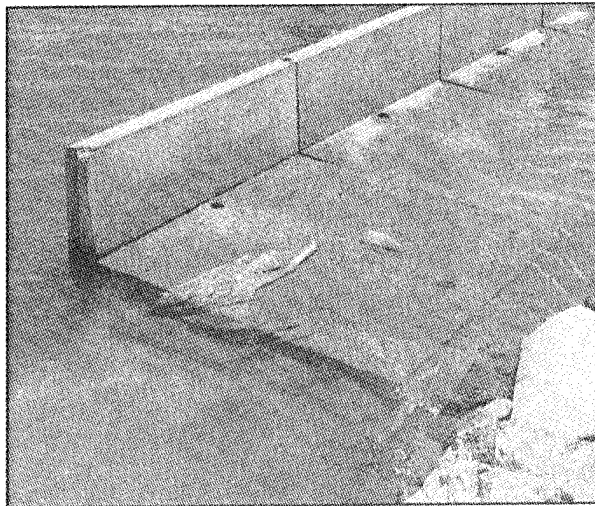

b. Unit in place

Figure 149. Precast concrete units used to provide shore protection at Birchgrove (from National Precast Concrete Association Australia 1991)

Corps of Engineers' Concrete Armor Systems

A survey of Corps sites that use concrete armor units identified nine rubble-mound breakwaters and jetties that use one or a combination of the following: dolosse, tetrapods, tribars, and quadripods (Markle and Davidson 1984). The armor units in all of the structures have experienced breakage, either during construction or in storms. None of the structures were reported to be in danger of failing because of the existing breakage, but several structures were being closely monitored to determine what effect, if any, the existing or additional armor unit breakage would have on the overall stability of the structures.

Subsequently, the Corps of Engineers developed a series of armor units, called the CORE-LOC series, that provide optimized armor units for protecting all coastal structures (Melby and Turk 1994). The CORE-LOC units were designed to be placed in a single layer on either steep or shallow slopes. Also, the shape of the unit was designed to have much lower stresses than existing slender armor units and to produce an armor layer with very little or no rocking units during design conditions. The units were also designed to be used for repair of existing dolos slopes. CORE-LOC units are currently being model tested for potential application at a number of Corp project sites.

Roadway Bridges

The principal advantages provided by precast modules for concrete repair, rehabilitation, and construction are economy and speed. Precasting eliminates the expense of onsite batching, placing, and curing. It can provide a more durable product because it offers a greater opportunity to control quality. It cuts construction time in that the casting can be done in an "off season" or while preparatory work is being done, and standardized units can be stock-piled for immediate use when needed. These advantages help make precast modules the most practical solution for replacing bridge decks.

Jediah Hill Covered Bridge

Built around 1850, the Jediah Hill Covered Bridge, which is located in Hamilton County near Cincinnati, OH, is listed in the National Historic Register. The wooden structure has a single, 15-ft-wide lane and a 43-ft 6-in. span supported by the original hand-hewn timber trusses.

The need for rehabilitation was a result of the age of the bridge, deterioration as a result of an increase in traffic caused by development in the area during the last 50 years, and the size of the bridge which was inadequate for fire trucks and other large vehicles.

However, because of its historic value, a decision was made to rehabilitate rather than replace the old covered bridge. The plan specified restoring the structural strength of the bridge, widening it by 2-1/2 ft, and increasing its

overhead clearance by 3 ft. Precast, prestressed-concrete voided-box beams were selected as replacement for the wooden beams because they (a) could be concealed in the space where the wood stringers and floor beams had been, (b) have few maintenance requirements, and (c) kept the original proportions of the covered bridge.

Five precast, prestressed-concrete voided-box beams were used. Each beam measured 21 in. by 36 in. by 44.5 ft. The beams were covered with a waterproof membrane and then with a wood plank flooring to preserve the original appearance. Timber curbs were added on each side. Also, the original timber trusses were incorporated as supports for both the bridge deck and the roof (Figure 150). The wood flooring and the trusses were bolted to the concrete. A new wood shingle roof completed the restoration. The rededication took place 13 June 1982 (Precast Concrete Institute (PCI) 1982).

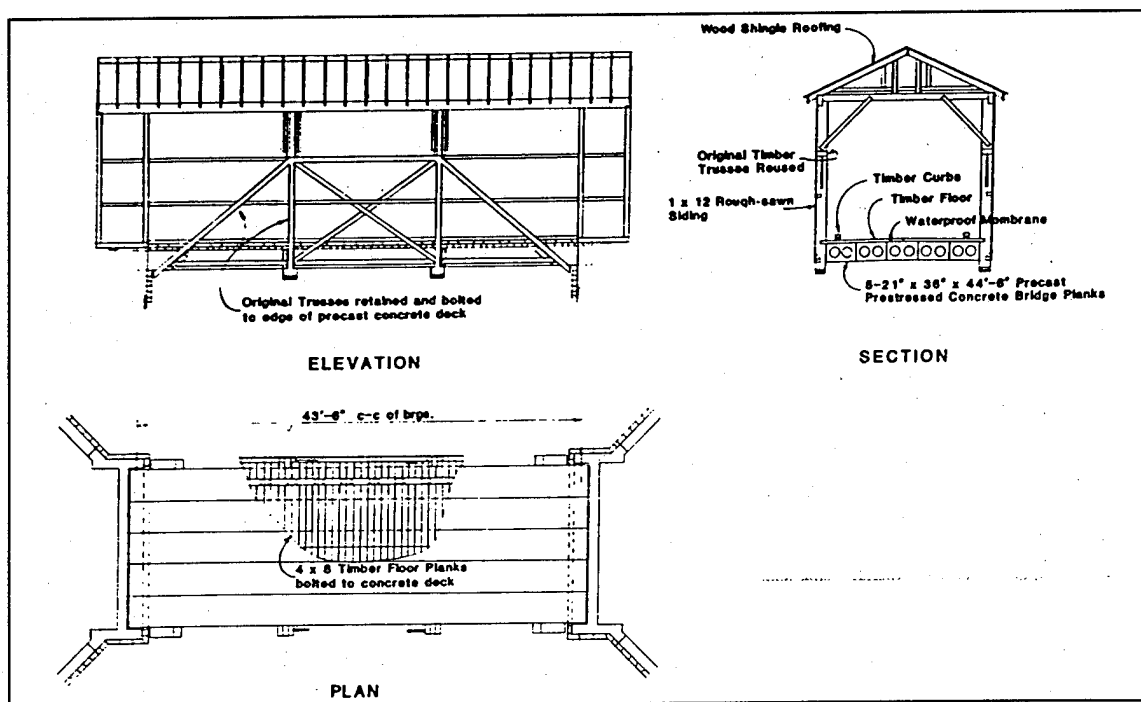

Figure 150. Restoration plans for Jediah Hill Covered Bridge (from PCI 1982)

The Dublin Scioto Bridge

The Dublin Scioto Bridge, constructed in 1935 as a Work Projects Administration (WPA) project, crosses the Scioto River as a part of Routes 161 and 33 near Columbus, OH. The bridge is a six-span, rib-arched structure with a stone facing (Figure 151). In 1985, the City of Dublin, owner of the bridge, recognized the need to repair and widen the bridge roadway. Fifty years of exposure to weather and traffic had resulted in extensive deterioration of the concrete deck, and by the mid-1980s, traffic on the bridge had increased to approximately 18,000 vehicles a day. However, area residents, although recognizing the functional necessity of the bridge, had come to value

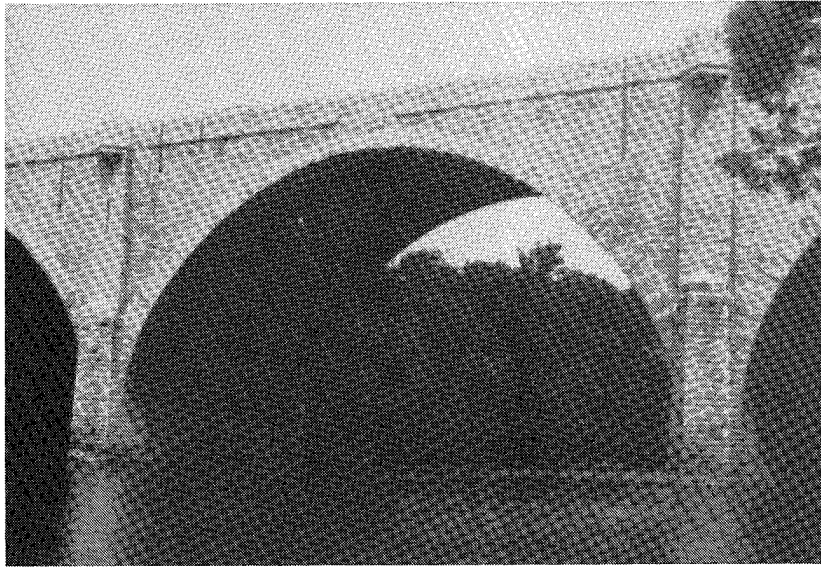

Figure 151. Dublin Scioto Bridge before rehabilitation (from PCI 1988)

its aesthetic appeal and did not want the bridge changed. The city fathers, being sensitive to the community's feelings, looked for a rehabilitation method that would meet the needs of the bridge and the desires of the community. This project was reported in PCI Journal (1988). That report is summarized here.

An inspection revealed that the arch spans did not require repair and could support a new deck. A decision was made to use precast concrete panels for the repair because precast panels would greatly reduce construction time and would provide a way to rehabilitate the Dublin Scioto Bridge without altering its general appearance.

The structural configuration of the old bridge was incorporated into the design of the new bridge with the panels being skewed 8 deg to match the original structure (Figure 152). Epoxy-coated steel was used for reinforcing (Figure 153). The panels were from 9 to 14 in. thick, approximately 10 by 28 ft, and weighed between 17 to 22 tons. The design called for two-dimensional prestressing which allowed the panels to overhang the outer arch, thus providing a wider roadway. The original roadway was 32 ft wide with two 3-ft-6-in.-wide sidewalks. The new roadway is 48 ft wide with one 8-ft-wide sidewalk.

The construction procedure was to remove and rebuild half of the bridge and then use the rehabilitated half as a work platform for construction of the second half. A total of 121 precast panels were placed in two rows to form the new deck. Once the panels were placed, they were posttensioned together in both directions (Figure 154).

The project was begun in January 1986 and was completed in 9 months, on schedule. Total cost of the project was approximately \$2.1 million; the

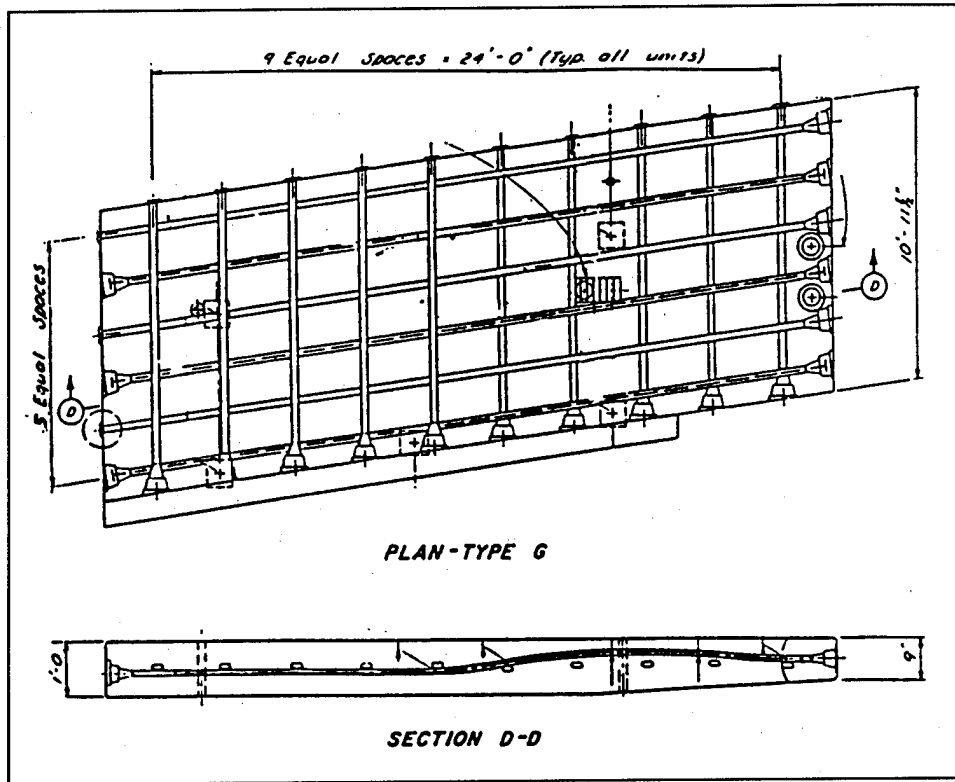

Figure 152. Panel prestressing layout, Dublin Scioto Bridge (from PCI 1988)

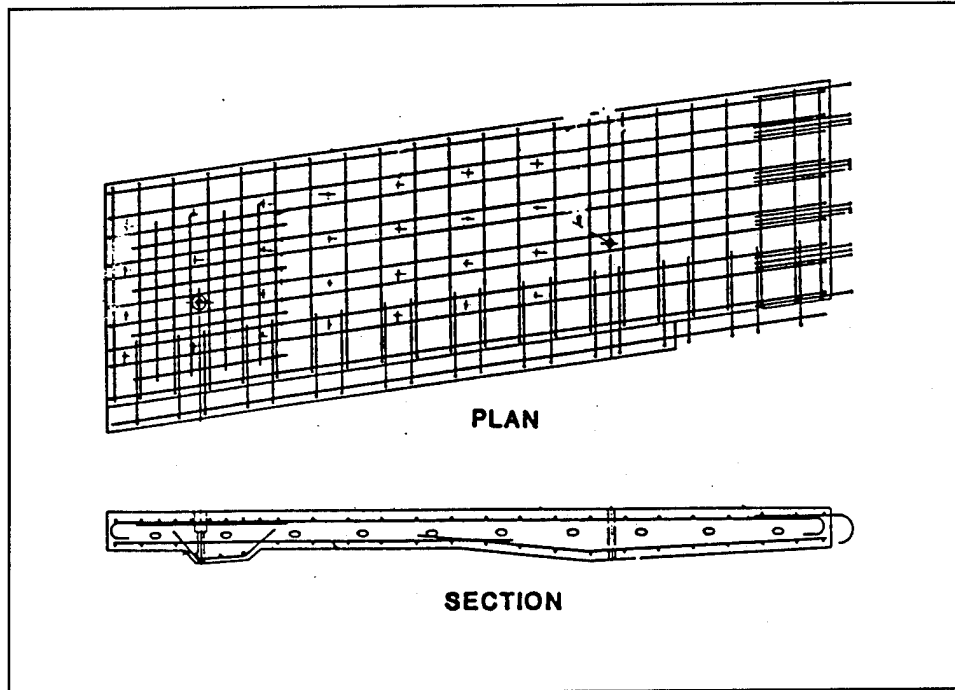

Figure 153. Details of panel reinforcing for Dublin Scioto Bridge (from PCI 1988)

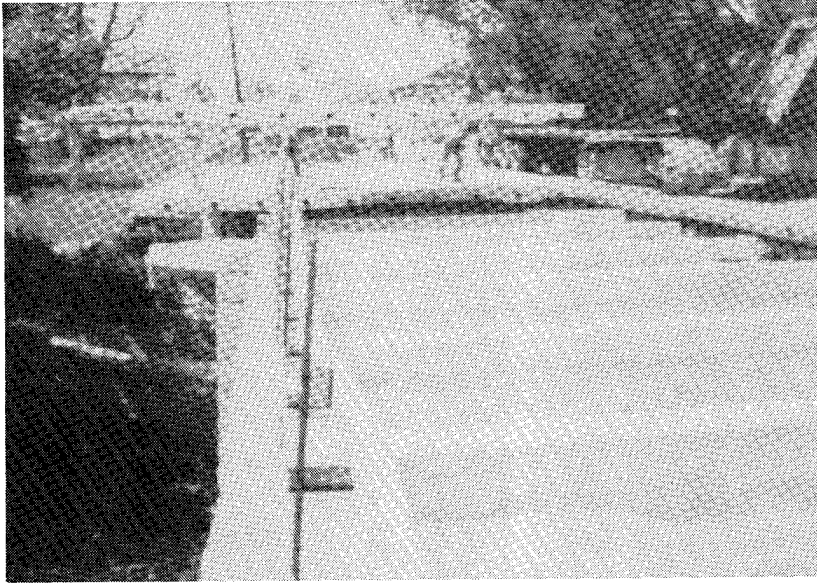

Figure 154. Precast panel placement, Dublin Scioto Bridge (from PCI 1988)

precast prestressed concrete work cost about \$600,000. The rehabilitated bridge is shown in Figure 155.

Maria Cristina Bridge

The Maria Cristina Bridge, located in San Sabastian, Spain, near the French border, was dedicated 20 January 1905. It was constructed across the Urumea River to provide a roadway between the city and the railway station. The bridge substructure consisted of three vaults, each with 79-ft spans, two 10-ft-wide central piers, and two massive abutments. The 66-ft-wide deck consisted of four 9-ft-9-in.-wide traffic lanes and two 11-ft-6-in.-wide sidewalks. The parapets were decorated with mythological lion heads, gilded dragons, blue glazed tiles, and oars, and the ends of the piers were bow-shaped as a reminder that the city was not far from the mouth of the river.

The vaults had a 6-ft-8-in. rise and a depth of 28 in. at the base and 24 in. at the crown. The internal structure of the arches was made up of steel lattices placed about 60 in. apart. The lattices were covered with a 10-in. layer of concrete. Longitudinal walls above the arches supported the deck slab. The entire structure was anchored on 16-ft-5-in.-long precast, reinforced concrete piles. Engineers tested the strength of the bridge by overloading a single span with sand to 102 psf. The crown of the bridge sank only 0.2 in.

Despite the strength indicated by the initial testing, serious deterioration of the concrete and steel in the bridge had occurred by 1985. Investigation and subsequent rehabilitation of this structure were described by Mainar and Arenas (1986); their report is summarized in this case study.



Figure 155. Dublin Scioto Bridge after rehabilitation (from PCI 1988)

Visual inspection revealed the pier bows on the south facade to be completely eroded; the surfaces of the vaults were spalled, and there was internal cracking. In some areas, sections of the steel lattice arches were exposed; in others, both the concrete and the steel were missing because of steel corrosion. The deterioration of the concrete was attributed to the aggressive marine environment, the lack of funding for maintenance, and the use of aggregate with an excess of large gravel stones and almost no medium or small stones.

The Municipality of San Sebastian decided the only viable solution to the problem was to demolish and rebuild the entire superstructure. Therefore, the city sponsored a contest in which contractors were invited to submit designs and plans for restoring the bridge. The main design requirement set by the

city was that the new bridge reflect the Spanish culture and architecture as the first bridge and other historic buildings and monuments did. The new bridge was to have the same volume and external form, including texture and color, as the original bridge.

The design selected was a spandrel-arch structure. Almost all of the load-resisting elements were precast. Construction began with the spandrel arches being placed on the pier heads and anchored temporarily with two prestressing tendons placed at the arch ends. The tendons were tensioned to produce a force equal to 117 kips for the external arch and 103 kips for the internal arch. When a row of three arches had been placed and the corresponding pier heads concreted, the temporary ties were removed. The arches were supported by the piers and abutments.

Next the 6.3-in.-deep precast, curved bottom plates were installed between the arches. Two 15.7-in.-wide separation strips were poured between the plates and arches, and the reinforcement from the two was crossed and anchored. Steel reinforcement was also placed across the transverse joints between two slabs. Poured-in-place concrete along these longitudinal and transverse joints changed the initial I-section to a U or equivalent section (Figure 156).

Precast, reinforced concrete beams were then placed over the transverse diaphragms of the arches at spaces of 10 ft 4 in. Concrete was then poured at the joints where the projecting reinforcement crossed. These transverse frames were tied at the bottom of the lower plates. Then the 7.9-in.-thick precast top slabs were placed over each "cell" formed by the longitudinal arches and transverse girders. Longitudinal and transverse channels (3 ft 11 in. wide and 7.8 in. wide, respectively) are formed over the arches and transverse girders. Transverse reinforcing bars projecting from the top of the slabs are crossed over the first channel to ensure resistance to continuity negative moments. Longitudinal top and bottom bars projecting from the top slabs are crossed on the transverse channels. Without the need of any formwork, the pouring of in-place concrete in this grillage of channels makes the entire deck monolithic. The cured concrete creates an interconnected structure which acts like a box section spandrel arch in the longitudinal direction.

The rectangular top placements acting like continuous slabs in both directions resist local flexure. General transverse flexure is taken by the rigid transverse frames described above. An efficient three-dimensional thin-wall structure is created.

Rural Bridges in Oklahoma

With 72 percent of its 15,174 rural bridges in need of repair or replacement and inadequate funding for such massive rehabilitation work, Oklahoma began searching for a better method for designing and building rural bridges. The search was conducted through the Center for Local Government Technology at Oklahoma State University. One objective of the study was to

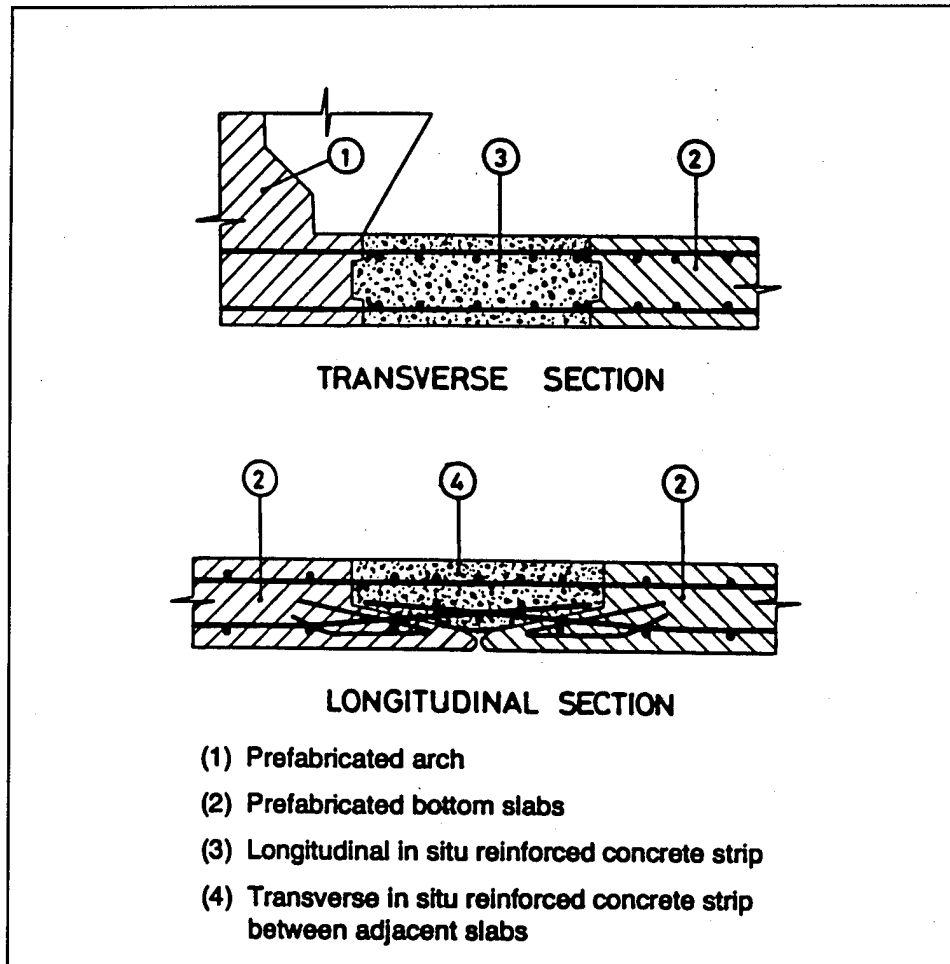

Figure 156. Details of transverse and longitudinal sections, Maria Christina Bridge (from Mainar and Arenas 1986)

obtain maximum benefit from existing funds and personnel. The Center's research into precast short spans designed for bridges between 20 and 25 ft indicates this method will be its best solution. *Roads & Bridges* (1985) described the installation of short-span bridges in Oklahoma; this case history is a summary of that description.

The short-span bridges consist of precast, reinforced concrete beams laid side by side and bolted together. The number of beams used depends upon the width of the roadway. The design for the beams is a modified double-T cross section with no prestressing. Specifications call for shear bars to be placed on 6-in. centers throughout the length of each beam. Tensile strength is developed by the placement of three No. 10 bars in each loop at the ends of the shear bars. Reinforcing bars are placed lengthwise through the beams, above and perpendicular to the shear bars. One-inch tie bars inserted through circular holes cast into the beams are used to bolt adjacent beams together. The top of each beam is 1 in. narrower than the body; the 2-in. keyway formed when beams are joined is grouted with a high-strength epoxy or high-density concrete to form a shear key to transfer load (Figure 157).

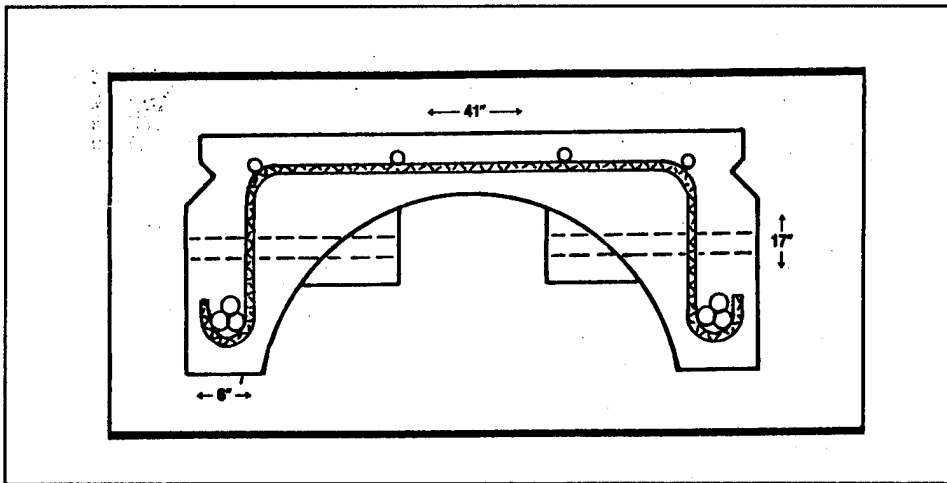

Figure 157. Cross section of precast beam showing placement of steel reinforcing in short-span bridge (from *Roads & Bridges* 1985)

The first bridge to be constructed with the precast short spans is located in Pottawatomie County near Shawnee. Installation of the precast beams forming the bridge roadway required less than 1 day after the bridge abutments were completed. Total cost for this bridge was \$30,600 excluding the forms (1985 dollars). Although this amount does not represent substantial savings over the concrete box construction method, the university believes the design can produce a savings of a minimum of 15 percent over conventional designs once local construction crews become familiar with the procedure. Also, additional costs were incurred at this site because the bedrock was unusually deep, so bearing piles had to be from 43 to 45 ft long.

Two additional bridges were used to test this method, another in Pottawatomie County and one in Osage County. The only change from design specifications was that Grade 60 steel was used for reinforcing in the three bridges instead of the specified 40 Grade. The heavier steel was used to compensate for the weight of the beams and to maintain the heavy load capacity. Also, bare steel was used in these bridges; future bridges will likely use epoxy-coated steel.

Financial benefits of this construction method are that the spans can be fabricated during the winter months or off-times and stored in county maintenance yards until needed and the forms for constructing the spans can be reused, thus saving site-construction time and cost of materials. Estimated cost of reusable steel forms is approximately \$4,500 per pair (Figure 158).

The university suggests use of a jig table to ensure correct placement of reinforcing. The jig table used by Pottawatomie County is made of channel iron and is constructed with notches that show where reinforcing steel is to be placed. Once the bars are arranged, the entire basket is lifted into the form, and then the concrete is placed. Pottawatomie County places two beams at a time.

Materials List (two sets of forms)		
Materials	Size	Quantity
channel	25'—15" × 33.9	5
angle	25'—2" × 2" × 1/4"	9
angle	4'—2" × 2" × 1/4"	4
angle	25'—2" × 2 1/2" × 1/4"	4
plate	25'6" × 1'6" × 1/4"	4
plate	4' × 1'5" × 1/4"	4
plate (rolled on 15" radius)*	25' × 3'6 1/4" × 1/4"	2
all thread w/ nuts	4' × 3/4"	6
reinforced concrete pads	26' × 5'5" × 6"	2
anchor bolts w/ nuts	6" × 3/4"	40
schedule 40 PVC**	20' × 1"	1
schedule 40 PVC**	20' × 1 1/4"	1

*Fabricated instead of standard. Increased draft facilitates removal of beams.
**Cut to fit to ensure vertical side forms.

Figure 158. Materials list for construction of two sets of forms for short-span bridges (from *Roads & Bridges* 1985)

The university research team believes this method of bridge construction will be cost-effective, will require a short construction period, and will increase the load-carrying capacity of short-span rural bridges.

Short-Span Bridges, Florida

The Florida Department of Transportation (DOT) experimented with deck modules for new short-span bridges. By standardizing full-span deck panels in a variety of widths, span lengths, and skews, they could provide a stockpile for both new construction and replacement. The panels they were experimenting with could be connected laterally and without girders to form a precast slab-type bridge.

Although the advantages of precast bridge deck modules are attractive, there are concerns about fatigue behavior and the durability of connections. Also, problems with moisture leakage between adjacent slabs occurred in early installations; subsequent installations have used sand-cement grout or epoxy mortar, which seems to have eliminated the problem. However, there are questions about the long-term durability of the grout or mortar that cannot be answered at the present (Slavis 1983).

The High Street Overhead

The High Street Overhead on State Route 17, Oakland, CA, is a 1,750-ft-long structure with 32 spans that vary in length from 30 to 75 ft. When the 30-year-old decking on one lane of the bridge had to be replaced, the California DOT elected to use precast concrete because of the heavy traffic--over 170,000 vehicles per day--and no available detour with a sufficient capacity for handling the traffic during lane closures. During construction, all lanes remained open from 2:00 p.m. to 6:00 p.m., the peak traffic hours; also there were closure restrictions on some weekends.

The precasting operation was set up in the right-of-way next to the jobsite (Figure 159). This arrangement eliminated transportation problems and allowed the contractor to cast the modules, which included the deck and parapet as one unit, in any size his crew and equipment could handle.

At 6:00 p.m. each weekday, crews began removing sections of the deck that would be replaced during that construction period. Instead of being broken up for removal, the deck was cut into large pieces which were lifted out with a crane. As soon as the deck sections were removed, the girders were cleaned and fitted with mechanical leveling devices in preparation for placement of the precast units; placement was scheduled to begin at 10:30 p.m. Calcium aluminate cement grout was placed on the girder flange to provide a bearing surface between it and the deck soffit. Shear connectors welded to the girders through blockouts in the deck were used to join the girders and deck. Calcium aluminate concrete with a compressive strength of 4,100 psi at 6 hr was used to fill the blockouts and as a final wearing surface for the bridge deck so that the bridge could be opened to traffic by the 2:00 p.m. deadline (Slavis 1983).

Woodrow Wilson Memorial Bridge

The Woodrow Wilson Memorial Bridge, a 5,900-ft steel-girder structure with a 212-ft drawbridge, was constructed in 1959-1962 by the Federal Highway Administration. The bridge, a part of I-95 that crosses the Potomac River in southern Washington, D.C., is operated and maintained by the District of Columbia, Maryland, and Virginia (Figure 160) (ASCE 1984). By 1977, the reinforced-concrete bridge deck had deteriorated to the extent that rehabilitation was imperative. Emergency repairs were required almost daily. Large pieces of decking were falling into the river, and there was concern that a vehicle might fall through the bridge. The Maryland State Highway Administration (MSHA) supervised the redecking (Halmos 1984).

The biggest obstacle to redecking was traffic; approximately 110,000 vehicles crossed the bridge a day. During peak hours, as many as 5,000 vehicles crossed in one direction in an hour. Therefore, scheduling repair time became a critical part of the repair-method selection. The final decision was to use a precast concrete slab system because it would not interrupt traffic

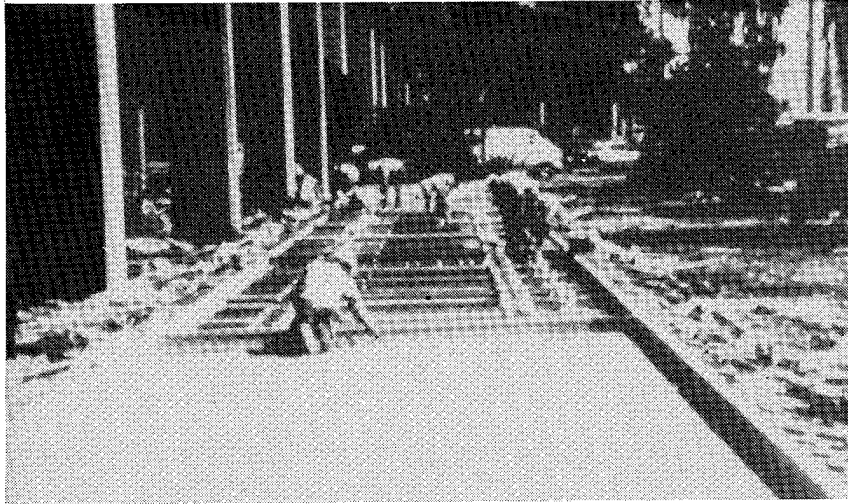

Figure 159. Panels for High Street Overhead were cast in right-of-way at jobsite



Figure 160. Woodrow Wilson Memorial Bridge, a major traffic area for Washington, D.C., and surrounding areas (from ASCE 1984)

during peak hours nor require total closure of the bridge at any time. The redecking was done at night when traffic could be channeled into two lanes on one-half of the roadway (Figure 161) (ASCE 1984).

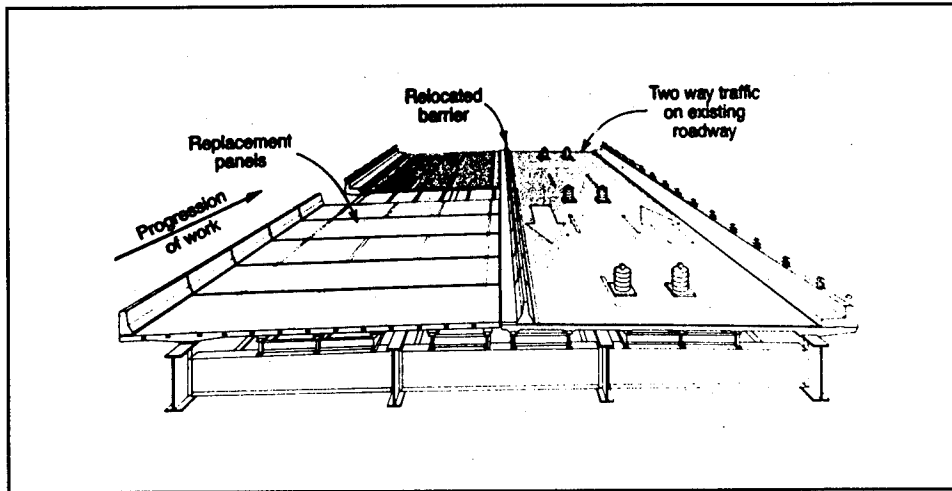

Figure 161. Barrier relocated at night so work on the Woodrow Wilson Memorial Bridge could continue (from ASCE 1984)

Concrete used for the precast slabs was a mixture of Type II cement, expanded slate, crushed limestone sand, an air-entraining admixture, and a retarding, water-reducing agent. The slabs measured 46 ft 7-1/4 in. by 10 to 12 ft by 8 in. with a 5-in. haunch at each exterior girder. All reinforcing steel was embedded to a depth of 2 in. The precast slabs were steam cured, transversely posttensioned, and finished with a two-coat epoxy-sand membrane. The membrane provided protection for the surfaces and bonded the 1-1/2-in. asphaltic concrete wearing surface to the slab. The slabs, which weighed approximately 27 tons, were shipped to the jobsite on flatbed trailers, where they were hoisted into place with barge-mounted cranes (Halmos 1984).

Preparatory work for slab placement included removing the deteriorated deck and sandblasting and painting the substructure. A 7-ft circular saw was used to cut the deck into 12- by 20-ft sections for removal. Four 50-ton hydraulic jacks were used to break the bond between the old deck and the girder flange. When this work was completed, workers installed the forms for the bearing pads and steel plates (Figure 162).

The precast slabs, each of which is supported by an exterior girder and five stringers, were placed on temporary steel shims (Figure 163). Cast-in holes in each slab were lined up with the bearing pad forms on the girder and stringers. The bearings are sliding steel plates on the top flanges of the stringer. The precast panels were tied to the structural steel with hold-down bolts that pass through the cast-in holes to plates placed under the stringer flange. Polymer concrete with a compressive strength of 4,000 psi at 1 hr (at temperatures between 20 and 100 deg F) and 8,000 psi at 24 hr was then poured through the cast-in holes to fill the pad forms, creating a concrete bearing pad (Halmos 1984). At this stage of construction, slabs were ready for traffic.

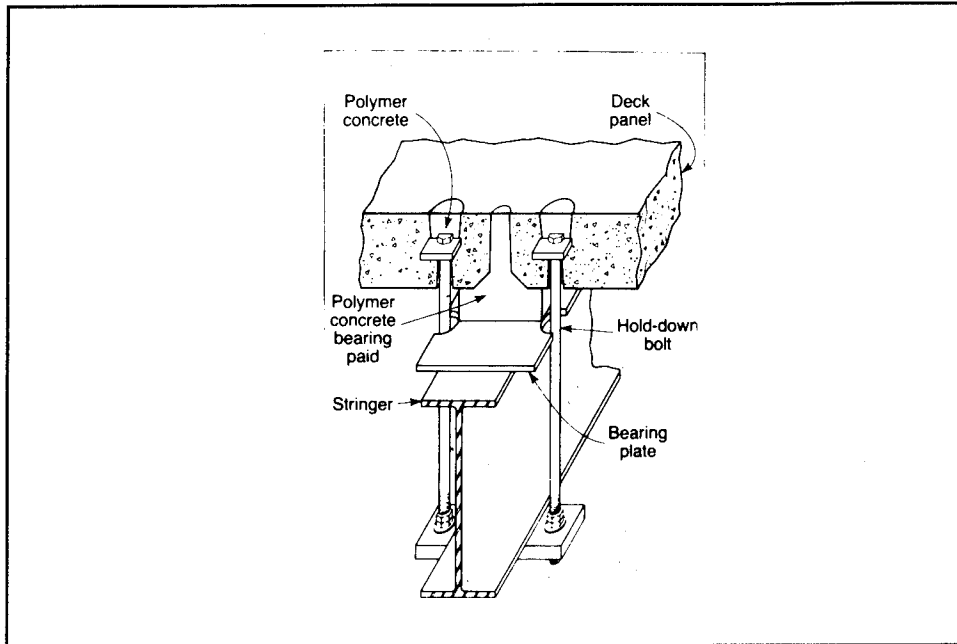

Figure 162. Bearing assembly, Woodrow Wilson Memorial Bridge (from ASCE 1984)



Figure 163. Painted steel and forms for bearing pads placed on stringers in section where concrete has been removed, Woodrow Wilson Memorial Bridge (from ASCE 1984)

Precast slabs were posttensioned longitudinally in groups, or segments, consisting of an average of 17 slabs. The length of the segments depended on the lengths of the continuous girders to which they were attached. A 4-ft space for posttensioning and installation of either steel expansion or contraction roadway joints was left between segments (Figure 164). Posttensioning the slabs in sections eliminated transverse joints and sealed out water. Instead of being bonded, posttensioning tendons were greased and covered with a plastic sheath. Thirteen groups of four 6/10-in. strands were carried in each posttensioning duct (Figure 165). (Oval ducts were used because of the thinness of the slabs.)

Prior to posttensioning the segment, the 1-1/4-in. space between slabs was filled with the same polymer concrete mixture as was used to fill the pad forms. After posttensioning was completed, polymer concrete was poured between the segments and the steel roadway expansion or contraction joints (Figure 166). The early high strength of this mixture allowed the repaired area to be reopened to traffic in a very short time. An epoxy coating was applied to all anchorage components, and epoxy grout or polymer concrete was used to fill anchor recesses to provide corrosion protection (ASCE 1984).

One modification that speeded up construction was the use of steel grates in place of removed-but-not-replaced bridge decking. The original contract stated that the number of deck sections removed would be equal to the number that could be replaced during a single construction period. However, workers were able to remove more than the estimated number of sections per night. By replacing these sections with steel grates until the new slabs could be installed, the contractor kept the bridge open to traffic and enabled the construction crew to begin placing the precast slabs at the beginning of the work shift (ASCE 1984).

The strength of the concrete, posttensioning the precast slabs at the casting plant and in segments after they were placed, and the thinness of the slabs eliminated the need to strengthen the superstructure. The bridge was widened from 89 ft to 93 ft 2-1/2 in.; the median was narrowed from 4 to 2 ft; and the safety walk on each side was removed to provide shoulders for disabled vehicles.

The new deck consists of 1,026 precast, lightweight concrete slabs. Redecking cost about \$41 per sq ft including removal, replacement, and traffic maintenance, or a total of \$21 million. The total contract for the project was approximately \$23,726,000 (ASCE 1984). This use of precast slabs for redecking was cost- and time-effective: cost was approximately \$9.2 million below the engineer's estimate, and the project was completed 225 days ahead of schedule (Halmos 1984).

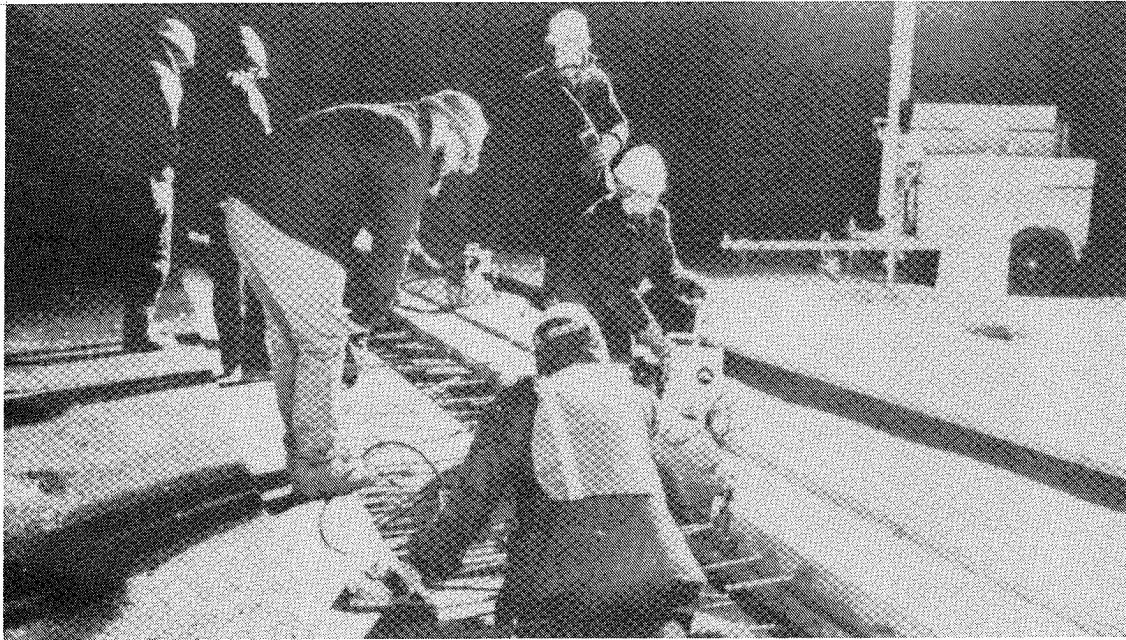

Figure 164. Space between anchor panels allows for posttensioning, Woodrow Wilson Memorial Bridge (from ASCE 1984)

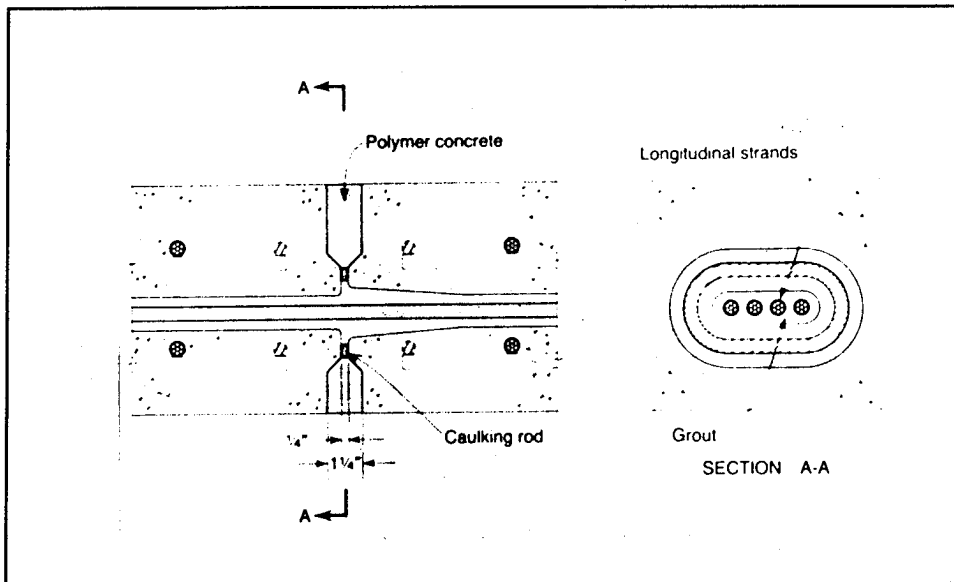

Figure 165. Typical segment joint, Woodrow Wilson Memorial Bridge (from ASCE 1984)

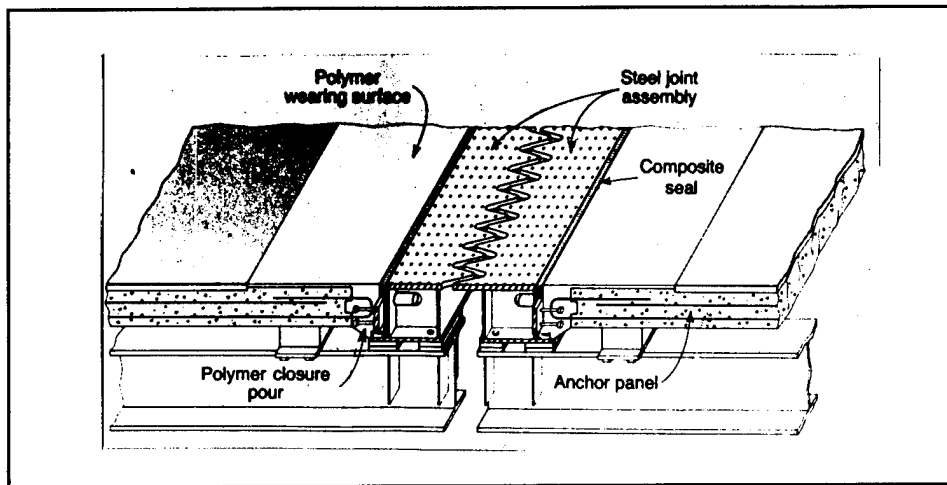

Figure 166. Steel expansion joint assembly, Woodrow Wilson Memorial Bridge (from ASCE 1984)

Fremont Street Bridge

The Fremont Street Bridge, constructed in the early 1930's, is a four-lane, concrete arch structure. The original parallel arches were 10 ft wide, 3 ft deep at the crown, approximately 5 ft deep at the spring line, and had a span of 180 ft. Concrete columns, measuring 8 by 2-1/2 ft projected from the arch to support the bridge. The columns were spaced on 15-ft centers and ranged from approximately 4 ft to approximately 40 ft in height. At each end of the bridge, column-floor beam-bents (columns that support transverse concrete bridge floor beams that cantilever over the outside of the columns) formed 60-ft approach spans. The beam-bents were supported on concrete footings founded on rock (Figure 167).

The three-span, continuous concrete deck consisted of a 40-ft roadway, two granite curbs, and two 9-ft sidewalks. The deck, which is 22 in. thick, was supported by 2-ft-wide floor beams and 1-ft-3-in.-wide spandrel beams.

Originally, the bridge deck was brick pavement. In 1953, this surface was replaced with 5 in. of reinforced concrete. By 1982, traffic in the area had increased considerably. Figures released by the Pennsylvania Department of Transportation (PennDOT) showed over 23,500 vehicles crossed the bridge that December. A private firm was contracted to do an in-depth inspection of the bridge. Smyers (1984) described the inspection and the rehabilitation; his report is summarized here.

Following the inspection, the sidewalks were closed because of the deterioration of the floor beams supporting them. Other components in need of replacement were the deck, sidewalks, spandrel beams, floor-beam cantilevers, and six floor-beam-column bents. In addition to rehabilitating the

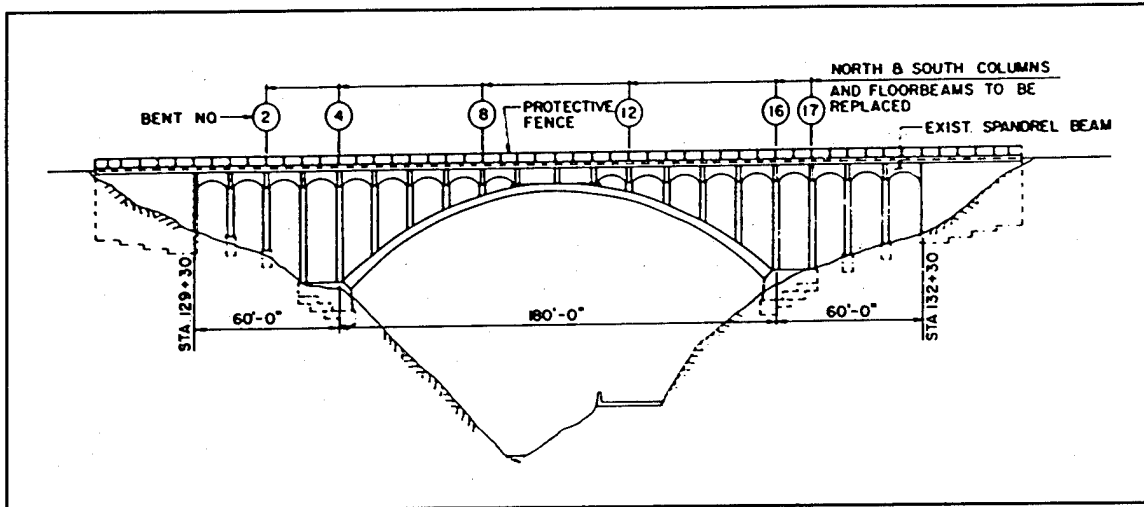

Figure 167. North elevation of Fremont Street Bridge (from Smyers 1984)

structure, PennDOT decided to widen the bridge deck to include four 12-ft-wide traffic lanes, two 5-ft-wide sidewalks, and two concrete parapets.

A controlling factor in the choice of a rehabilitation method was the necessity of keeping the bridge open to traffic and maintaining access to nearby businesses. In order for the bridge to remain open to traffic, construction would have to be accomplished two lanes at a time. Therefore, the floor beams would have to be cut in half. The side of the bridge not being repaired would require a temporary support system near its center. Once this structure was in place, the deck, sidewalk, spandrel beams, and floor-beam cantilevers would be removed, as well as one-half of each of the floor beams. Then this side of the bridge would be rehabilitated as Phase I; the second half, as Phase II (Figure 168).

Cutting the floor beam in half presented design problems. The new beam would require a moment connection at the splice, which would be made 4 ft 6 in. from the center of the bridge. The location of the splice would place it 4 ft 6 in. from the maximum positive moment region of the floor beam. The beam would also require a moment connection at the floor beam-to-column interface (Figure 169).

Alternatives considered for the floor beam included a cast-in-place beam, a steel floor beam, and a precast floor beam. A precast, posttensioned floor beam was selected because it minimized shoring and formwork, allowed for efficient connections and splices, and preserved the esthetics of the structure while requiring minimum maintenance.

A two-dimensional computer model was used to analyze concrete proportions, loadings, and stresses at the moments, shears, and axial member forces for the floor beams and columns. The final design requirement was a posttensioning system for the accepted cross section and prestress force. The design selected for the floor beam was 2 ft wide and 5 ft 3 in. high at the splice. On

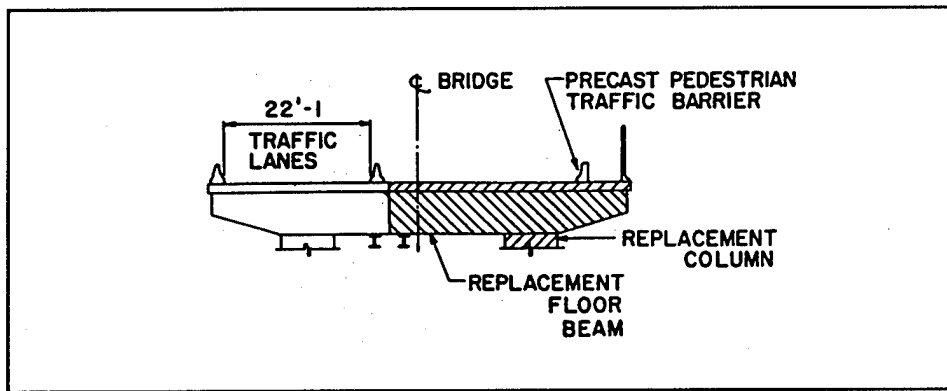

Figure 168. Traffic lanes on one-half the Fremont Street Bridge were kept open during construction (from Smyers 1984)

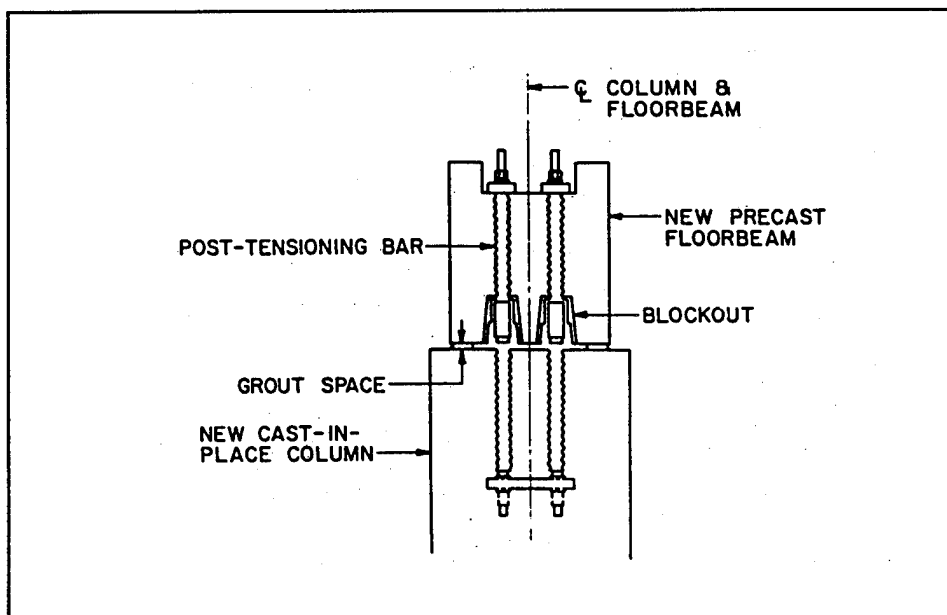

Figure 169. Cross section showing the floor-beam column bent for the Fremont Street Bridge (from Smyers 1984)

each side of the column, the width decreased to 1 ft 6 in. and the height to 5 ft at the column. At the end of the beam, the height is 3 ft. Concrete was proportioned to reach a strength of 6,000 psi. The prestress working force of the beam was 520 kips; the estimated jacking force, in excess of 675 kips.

The concrete mixture for the cast-in-place columns had a strength of 4,000 psi. A 3-ft-6-in. bearing plate embedded in the tops of the columns served as a mechanical connection that transferred moment between the floor beam and column. A 150-ksi, threaded prestressing bar encased in a plastic duct (to prevent bonding between the bar and the concrete) provided a stressing length of 3 ft 6 in. in the column and 5 ft in the floor beam. The

prestressing bar was extended from the column to accommodate the jacking scheme and, with the addition of a coupler, to reach the top of the floor beam, where the bearing plate was installed in a concrete blockout (Figure 170). The floor-to-beam connection consisted of four posttensioned bars.

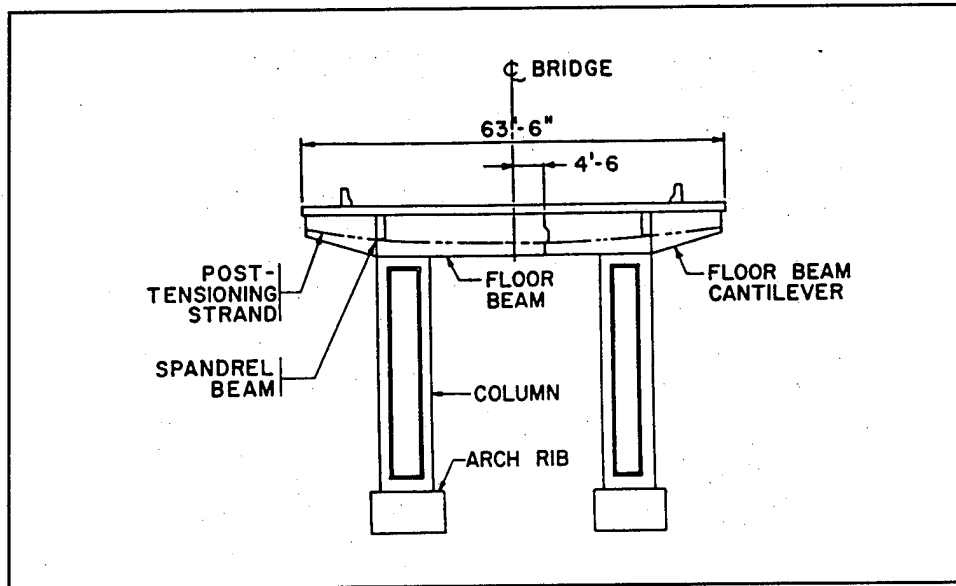

Figure 170. Details of a floor-beam-to-column connection with a two-piece prestressed bar assembly, Fremont Street Bridge (from Smyers 1984)

In selecting a deck design, engineers considered several configurations, including a cast-in-place deck spanning 15 ft between floor beam centers, a cast-in-place deck on a steel stringer subsystem, and a precast deck. Precasting was selected because it is less weather dependent, provides for better quality control, eliminates forms and batching on the jobsite, can be reopened to traffic in a short time, saves time as precasting of other elements and preparatory work can be done at the same time, and requires minimal effort for erection of the slabs. Specifications for the deck slabs called for concrete with a psi of 6,000. Ten 30-ft-long, 10-in.-thick slabs make up a deck cross section. The two center slabs in the cross section are 5 ft wide; all others are 6 ft 8-1/2 in. wide (Figure 171). Compression seals at each end of the slabs provided for thermal expansion. Female shear keys transferred shear between the longitudinal slabs; after placement, the shear keys, which had compressible grout barriers at the bottom of the keys, were filled with polymer mortar (Figure 172).

Each slab had six 1-1/8-in.-diam leveling bolts, which were aligned with 4- by 4- by 1/2-in. stainless steel plates embedded in the tops of the floor beams. The steel plates served as temporary bearings for pressure transmitted by the 12-ton slabs through the leveling bolts. Neoprene bearing pads with polymer grout pumped under them provided the permanent bearing. The pads allowed rotation at the supports, prevented hard spots from developing, and supplied firm bearing through the full width of the slab. Leveling screws were used to

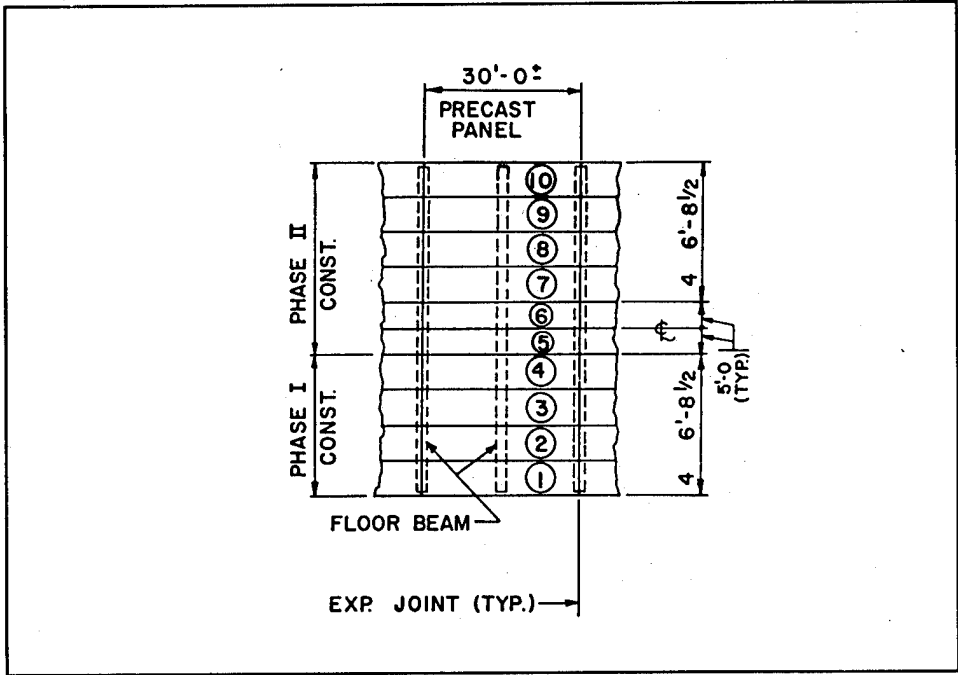

Figure 171. Layout of deck section with 10 precast slabs posttensioned transversely, Fremont Street Bridge (from Smyers 1984)

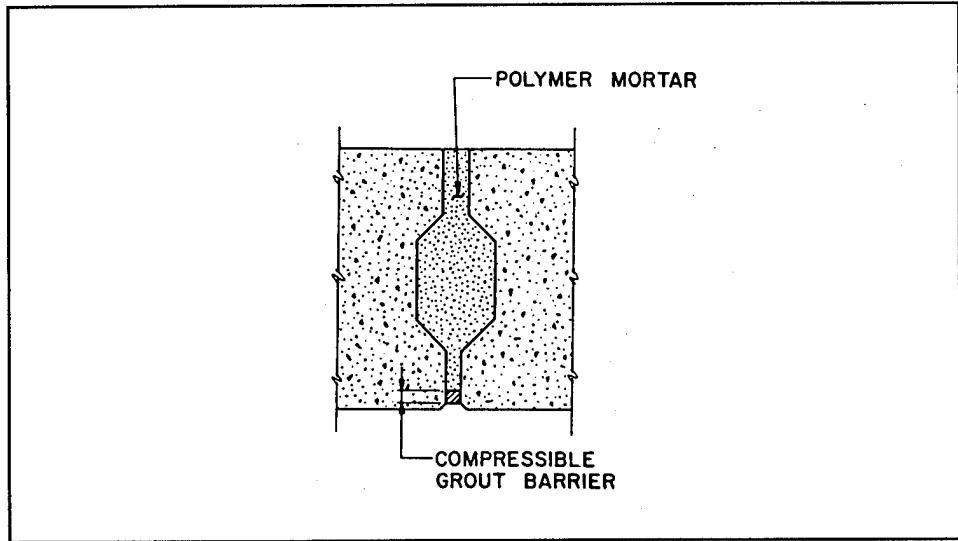

Figure 172. Detail of female shear key, Fremont Street Bridge (from Smyers 1984)

level the surface of the deck; however, slight variations in slab thickness resulted in some space being left between the bottom of the deck slab and the top of the floor beam. This space was filled with polymer grout (Figure 173).

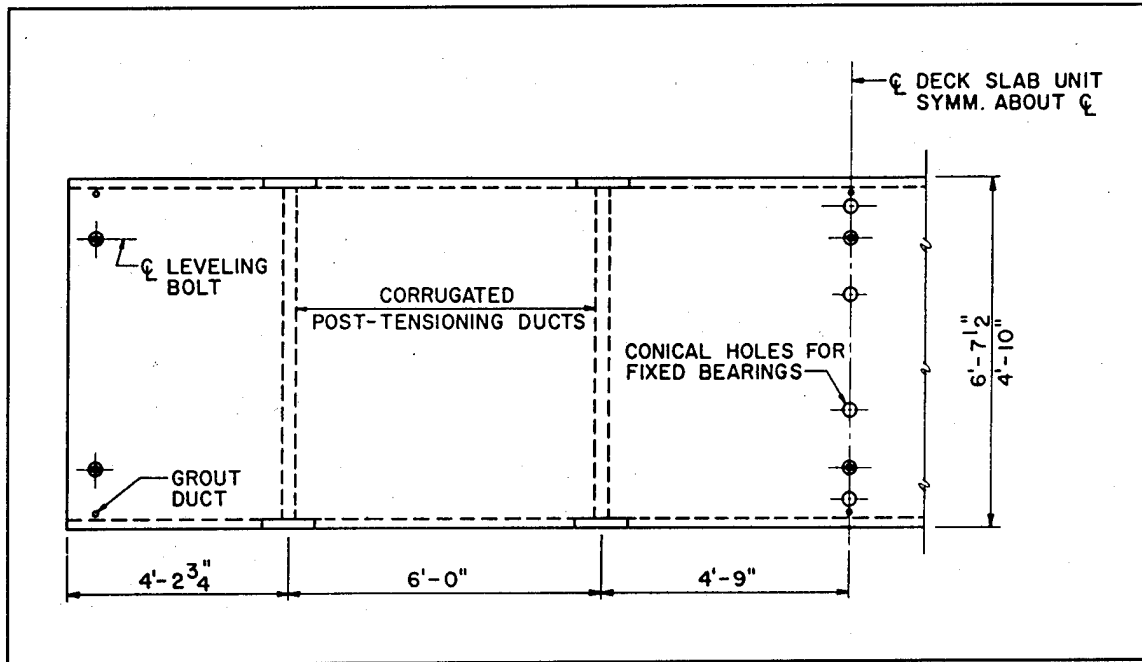

Figure 173. Sketch showing location of leveling bolts and posttensioning ducts, Fremont Street Bridge (from Smyers 1984)

Each slab was anchored to the floor beams with four 1-in.-diam dowels. The dowels were secured with polymer grout. Once slabs were installed the full width of the deck, they were posttensioned transversely to a working force of 20 kips. The posttensioning helps prevent cracking between slab joints. The leveling bolts were removed, and the inserts and blockouts were filled with polymer mortar as the final step of Phase I construction.

In Phase I, 300 ft of decking was installed. This portion of the project was completed and the deck ready to support traffic in a 1-week period. Phase II was essentially like Phase I, except that the transverse posttensioning bars were extended across the complete deck. Phase III consisted of completing the approach at the center of the roadway. Curbs, sidewalks, permanent traffic barriers, light standards, and a protective fence on the north side of the bridge were put in place during Phase IV.

The Fairbanks River Bridge

The Fairbanks River Bridge near Farmington, ME, was built in 1930. It is a part of Route 4 that crosses the Sandy River. At the time of construction, the bridge was not skewed to the river. Over time, the alignment of the main river channel changed so that by the mid-1980s it approached the bridge piers at a 50-deg skew. On 1 April 1987, the bridge was washed out by a flood

with a discharge estimated to be equivalent to a 100-year storm. The flood waters channeled against the west embankment and struck the west pier at a 70-deg skew, destroying the bridge.

The Maine DOT decided to use precast concrete deck panels in rebuilding the bridge. The decision was based on potential savings in construction time and recommendations from the University of Maine, where a feasibility study on the use of such panels had just been completed. This case history is a summary of a report (Conboy 1989) on the rehabilitation of Fairbanks River Bridge.

The precast concrete replacement panels were 3-1/2 in. deep and 8 ft wide. Prestressing strands with a 3/8-in. diam were placed at middepth of the panels. When cured and ready for installation, the panels were placed on a temporary blocking of high-density polystyrene so the proper haunch depths could be acquired. The 1-1/2-in.-wide polystyrene strip was attached to the top flange of the girders with an adhesive.

The change in channel alignment resulted in relocation of the bridge abutments and new roadway approaches. The required roadway super-elevation-transition-haunch variations complicated placement of the panels on the west end of the structure. Shims were used to keep the panels stationary on the temporary blocking. Shear studs were attached, and then a nonshrink mortar grout was placed across the full width of the flange to provide permanent support for the panels. A superplasticizer was added to the grout to create a more workable mixture, thus ensuring a full bearing and preventing the formation of voids under the panels. Because of the skew at the abutments, cast-in-place concrete was used for the full depth at each end.

The completed deck is 8 in. deep. The wearing surface is a 3-in. layer of bituminous concrete covered with membrane waterproofing. The length of the bridge was increased by 72 to 336 ft, the new length being determined through hydraulic calculations and projections of the new streambanks through the bridge site. A total of 210 precast concrete panels were used to form the new bridge deck.

The substructure consists of steel H-piles driven into bedrock. Superstructure steel is A588 weathering steel. Heavy riprap has been placed in front of the abutments and around the piers.

Connecticut and Chicopee River Bridges

The Massachusetts Turnpike Authority elected to use precast panels to redeck the bridges over the Connecticut and Chicopee Rivers. The decision was based on having a limited time for construction, traffic control and safety during construction, and a long, narrow jobsite with restricted access. It was felt precast panels would meet these requirements better than cast-in-place construction.

Preparatory work was performed during the winter; while the panels were being cast in an indoor casting yard, the deteriorated deck was being removed and the superstructure rehabilitated. Once the framework was ready, the panels were transported to the jobsite. Specifications for the precast panels called for concrete with a dry unit weight of 115 lb/cu ft and a compressive strength of 5,000 psi at 28 days. However, a mixture with a compressive strength of 4,000 psi was required to release the prestressing strands and to meet a 1-day turnaround time. Therefore, the mixture produced by the plant always had a strength greater than 5,000 psi.

Panels were approximately 40 ft by 8 ft by 7 in. thick. Each panel was prestressed to 200,000 psi. An articulating crane was used to place the precast panels, beginning at the center and alternating spans so the operation could be continuous. Spans were posttensioned to 207,500 psi and then grouted in place. Total cost for the 1,224-ft project, which was accomplished a quarter-deck at a time over a 4-year period, was approximately \$11 million (*Rural and Urban Roads* 1983).

Pennsylvania Turnpike

The Pennsylvania Turnpike Authority replaced the deck on a 1,627-ft-long, 140-ft-high bridge on the northeast extension of the Turnpike. The decision to use precast concrete modules was based primarily on economy and safety. Also, having the modules cast in a plant provided for better control of the concrete mixture, vibration, and curing.

One half of the bridge remained open for traffic, so the old deck could be removed and the steel girders sandblasted while the modules were being precast and cured. Each 7-ft-6-1/4 in.- by 28-ft-8-in.- by 6-3/4-in. slab weighed approximately 18,000 lb. The slabs were transferred to the site by truck and unloaded from either the completed portion of the bridge or the traffic lane. No modules were stored onsite. The precast concrete modules were connected to the girders with epoxy mortar and bolted spring clips on the edge of each module. The modules were connected to each other with 7/8-in.-diam steel rods. The entire deck was covered with 1-1/4-in. bonded latex-modified concrete (Slavis 1983).

Krumkill Road

The New York State Thruway Authority used precast concrete deck modules to replace an entire deck on the crossing at Krumkill Road. The modules for the repair were cast in a nearby plant and brought to the construction site by truck. A crane was used to transfer the precast sections from the truck directly to the repair. Epoxy mortar was applied to the girders as a bonding agent before the sections were placed. The crew carefully aligned the sections and welded stud connectors in each shear-key pocket to the girders. The final step was the grouting of the joints and blockouts. Traffic was kept open by being directed over a parallel bridge during construction (Slavis 1983).

Kansas River Bridge

Precast concrete panels were used as stay-in-place forms for the redecking of the Kansas River Bridge. The precast, prestressed panels, which reached from girder to girder, were 7-1/2 ft by 8 ft by 3-1/2 in. Prestressing strands doubled as a bottom-layer of reinforcing steel. Panels to be used for the deck edge were cast with the safety parapet as one unit (Figure 174).

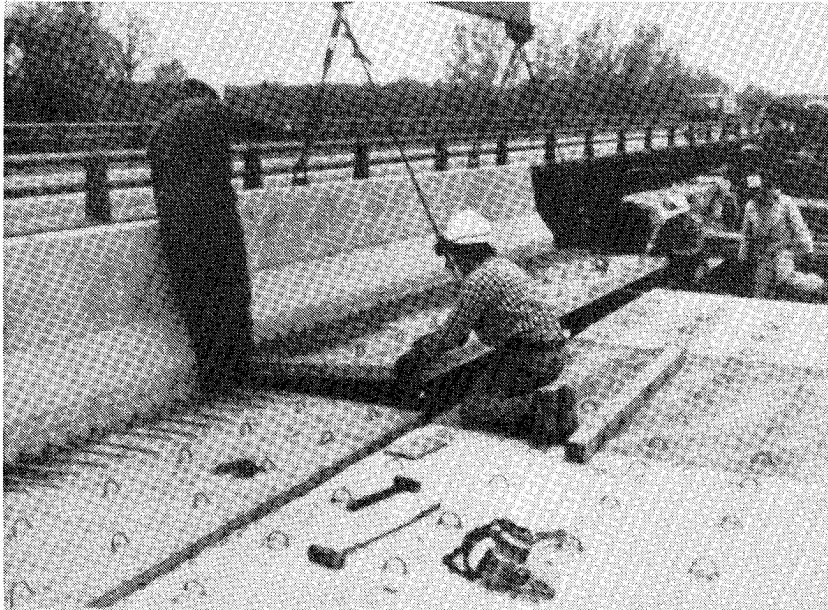

Figure 174. Workers placing a precast edge panel with a safety parapet on the Kansas River Bridge (from Slavis 1985)

Removal and replacement of the decking were done in sections of about 25 ft. The old deck was cut into 10- to 15-ft slabs, removed to a flatbed truck with a truck-mounted crane, and hauled away. The girders were sandblasted and painted prior to installation of the precast panels.

The edge deck panels with the parapets extended approximately 5 ft beyond the beam. Brackets were attached to the steel girders to provide support for the panel and curb until the 5-in., cast-in-place concrete surface became strong enough to sustain the cantilever (Figure 175). The rails were attached to the cast-in inserts used to help lift the panels (Slavis 1985).

Ulsterville Bridge

Because this bridge spans a Class 1 trout stream in Ulsterville, NY, it was necessary to minimize onsite construction activities. Consequently, precast concrete components were used in September 1989 to construct the bridge abutments and deck.

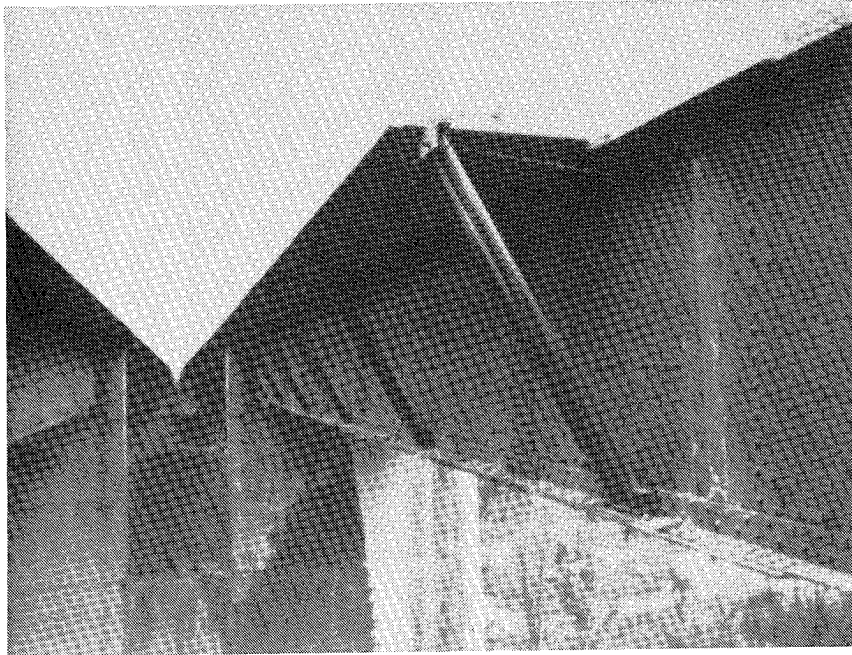

Figure 175. Brackets attached to girders provide temporary support, Kansas River Bridge (from Smyers 1984)

Precast modules of reinforced concrete stacked on a base slab were used to construct the abutments (Figure 176.) The modular units were precast in “start-up” wood molds, which resulted in some minor fitting problems in the field; however, adjustments were made without the construction being interrupted.¹ Once the modules were properly positioned and aligned, the back cavities in the units were filled with select granular backfill. Vertical reinforcing steel was inserted into the front cavities, and these cavities were filled with cast-in-place concrete to form a sealed, monolithic-like front wall (Figure 177).

Once the abutments were completed, the precast deck was installed. The composite deck units were precast upside down in forms suspended from wide flange steel girders. Stud shear connectors were welded to the girders. This technique uses the weight of the forms and the concrete to produce a prestressed effect of the girders. Another result of the upside down casting is that the densest, least permeable concrete is on the wearing surface. When the cured deck units were turned over, the concrete was precompressed, which increased its resistance to cracking.

The deck units were placed with a crane; steel diaphragms were installed between the units, and then all longitudinal joints were sealed with grout. The bridge was ready for traffic as soon as construction was complete (Figure 178).

¹ Personnel Communication, 1992, Peter J. Smith, The Fort Miller Co., Inc., Schuylerville, NY.

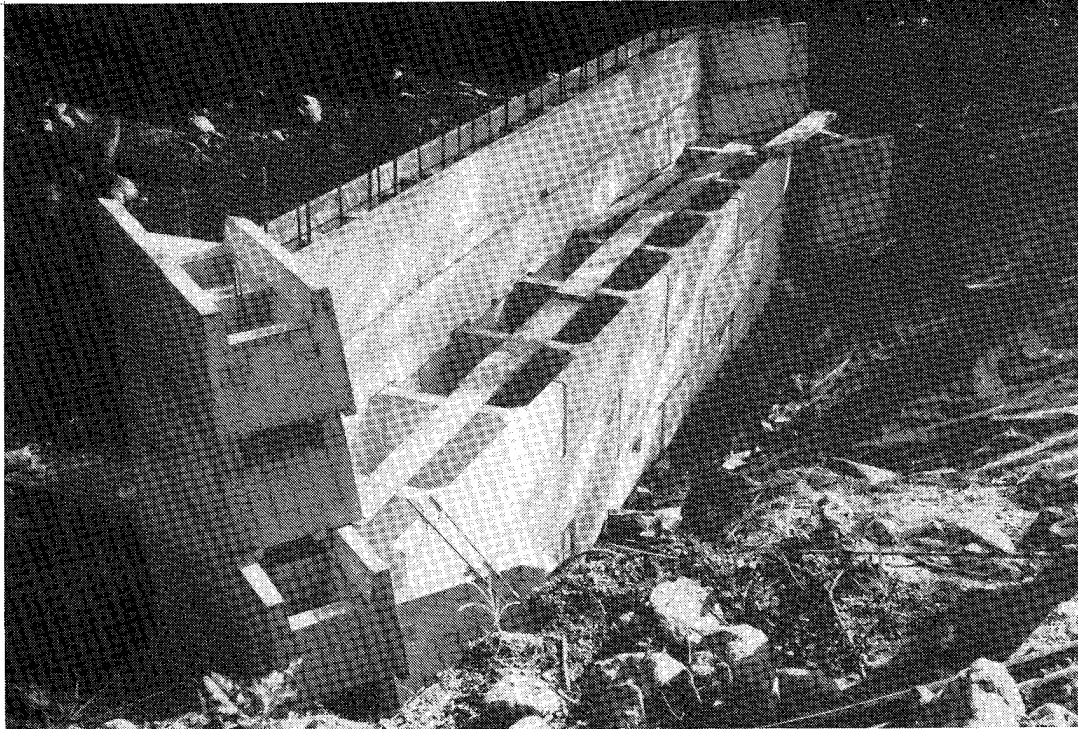

Figure 176. Top view of precast abutment prior to backfilling, Ulsterville Bridge

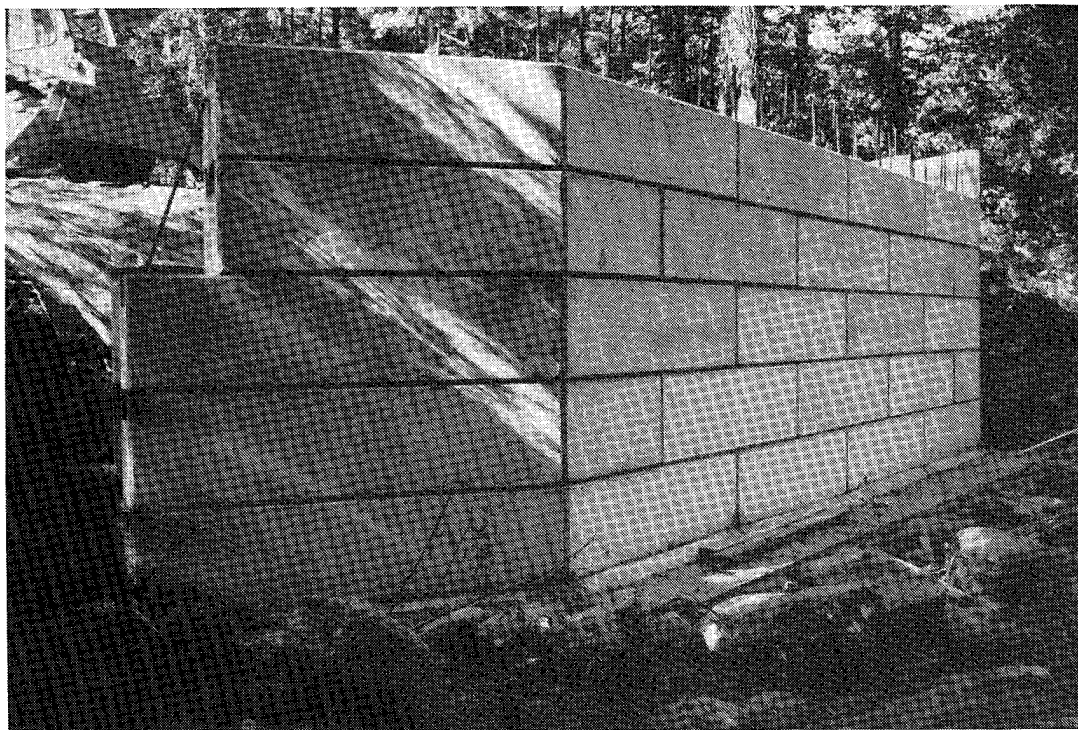

Figure 177. Front view of precast abutment prior to placing concrete cap, Ulsterville Bridge

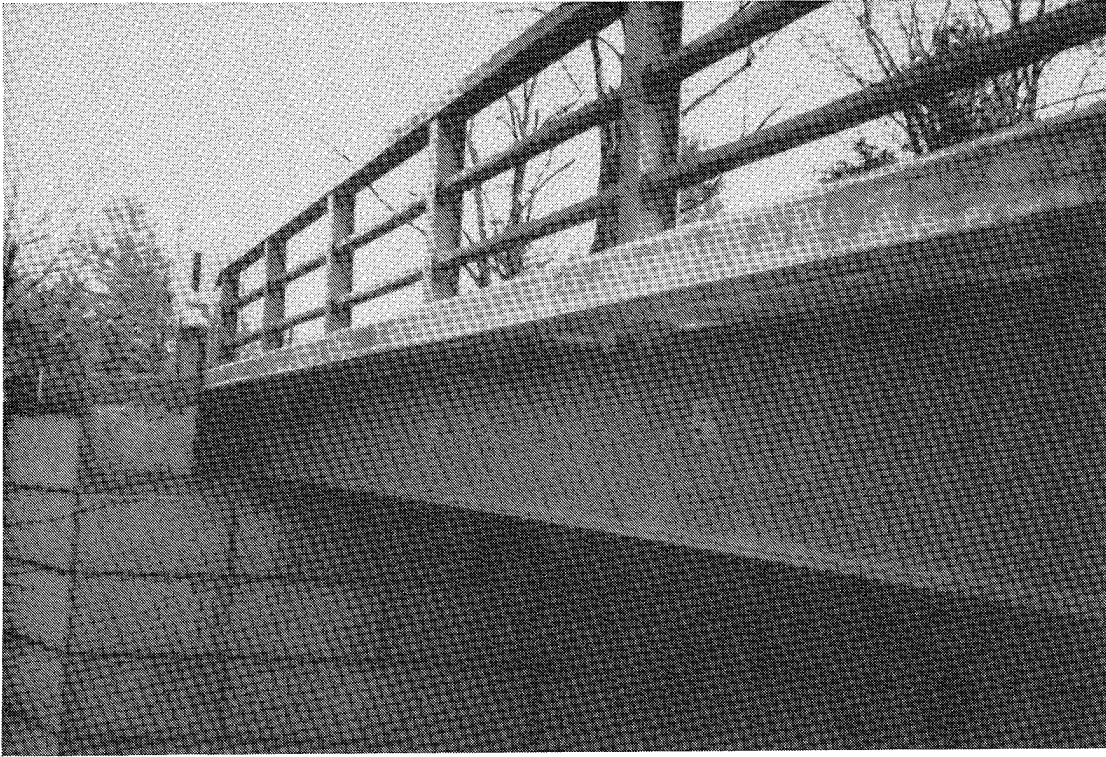

Figure 178. Precast abutment and deck units, Ulsterville Bridge

Since all components were precast, a small local contractor was able to complete the project within a few days. The cost of the bridge was very competitive with alternate construction procedures, and there was minimal environmental impact on the existing trout stream.

The Colorado River

To reduce construction time and increase safety, precast cofferdams, which were later incorporated as pier stems, were used in the construction of a bridge over the Colorado River. The bridge is a part of I-70 that runs through a scenic area in Glenwood Canyon, Colorado. This case study is a summary of a report by Walter Munn (1987).

The bridge is supported by four piers that rest on 72-in.-diam caissons drilled 10 ft into bedrock. Three 48-in.-diam caissons drilled 3 ft into bedrock support each abutment. The original plan specified that the piers would be cast-in-place; however, since the tops of some of the caissons were 20 ft underwater, the work would have required extensive use of cofferdams and possibly divers. As an alternative, the contractor decided to extend the caissons so the tops would be about 2 ft below low water and to use precast cofferdams with bases that would extend below the level that was originally planned as the top of the caissons. The caissons would be filled with approximately 2 ft of tremie concrete, pumped dry, and filled with conventional

concrete to form the lower part of the pier stems. The upper 10 ft of each pier stem would be cast-in-place.

The cofferdam bases were cast first. Each 16-in.-thick base was designed with an 84-in.-diam hole in the center and projecting reinforcing bars for attaching the mesh reinforcing for the walls. The outer form was fastened in place around the base; the interior mesh was attached, and then the inner forms were situated. The concrete was delivered in ready-mix trucks, placed by bucket, and consolidated with hand-held vibrators. Initial cure time was 48 hr.

Reusable forms were used for casting the sides of the cofferdams, which ranged from 5 to 20 ft high. The taller units were cast first, and then the forms were cut down for the shorter units. Panels for the interior and exterior forms were made of 4- by 6-in. walers and strongbacks. Interior panels were fastened together with shims so they could be removed from the inside. Exterior panels were held in place with heavy steel plates bolted to the walers during precasting. These plates were removed after the concrete had cured. These exterior panels were also used for the cast-in-place pier stems. A 24-gauge expanded mesh was used inside the interior panels to form a rough interior cofferdam surface. This rough surface improved the bond with the tremie concrete.

Each completed cofferdam was lowered in place with a crane. The caisson fit in the hole in the base; a neoprene seal attached to the bottom of the base stopped grout loss. After the cofferdams were filled with tremie and conventional concrete, the cast-in-place pier stems were constructed. A concrete cap beam was installed across the completed piers, and then the four steel girders used to form the five-span structure were placed. The contractor was then ready to form the bridge deck.

The 14-month project, which consisted of the 631-ft-long bridge and about 1,000 ft of approach road, cost approximately \$3.8 million.

Wears Creek Bridge

Standardized precast concrete arches placed side by side were used to replace an old concrete bridge that crossed Wears Creek in Jefferson City, MI (Hurd 1990). The precast concrete arches for this project were 6 ft wide, 12 in. thick, and 25 ft high. Each arch was cast in two sections. A crane was used to place the sections on prepared footings. Temporary scaffolding was used to support the arches while a cast-in-place center joint was installed (Figure 179). Earth fill was placed over the arches, and then standard roadway paving was placed on top of the fill. The earth fill protects the arch and the roadway from temperature extremes and weathering common to typical bridge installations.

Precasting and standardization of arch sections provide an economical and aesthetically pleasing way of bringing the arch to short-span highway



Figure 179. Precast arch sections being installed at Wears Creek (from Hurd 1990)

structures. Several proprietary arch systems are available in the United States. The system used at Wears Creek originated in Switzerland in 1966. The same system with the addition of precast wingwalls and headwalls was used to erect a 132-ft-wide arch-box bridge in Grand Rapids, MI (Figure 180). Twenty-two precast concrete units, each with a 9-ft-8-in. arch, and 10 precast wingwall pieces were erected during 1 day.

Kent County Box-Arch Bridge

In order to obtain Federal funds for a paving project, the Kent County (MI) Road Commission needed to widen an existing 60-year-old three-span bridge. Engineers for the county opted to use a new precast concrete arch-box system developed in the United States to replace the old bridge rather than widen it. The United States structure is similar to the Swiss arch system. The precast concrete units have wide cross-sectional areas that make them particularly suited for areas with limited vertical clearance (Hurd 1990).

Each arch-box unit used to construct the 114-ft-wide bridge was 6 ft wide, had a 36-ft span with a 10-ft rise, and weighed 26 tons. After cast-in-place footings were prepared and shims placed (Figure 181), the precast arch-box sections, which had been delivered on low-boy trailers, were lifted into place with a crane (Figure 182). Each placement required about 25 min. To reduce stress from handling, temporary cable struts were bolted across the

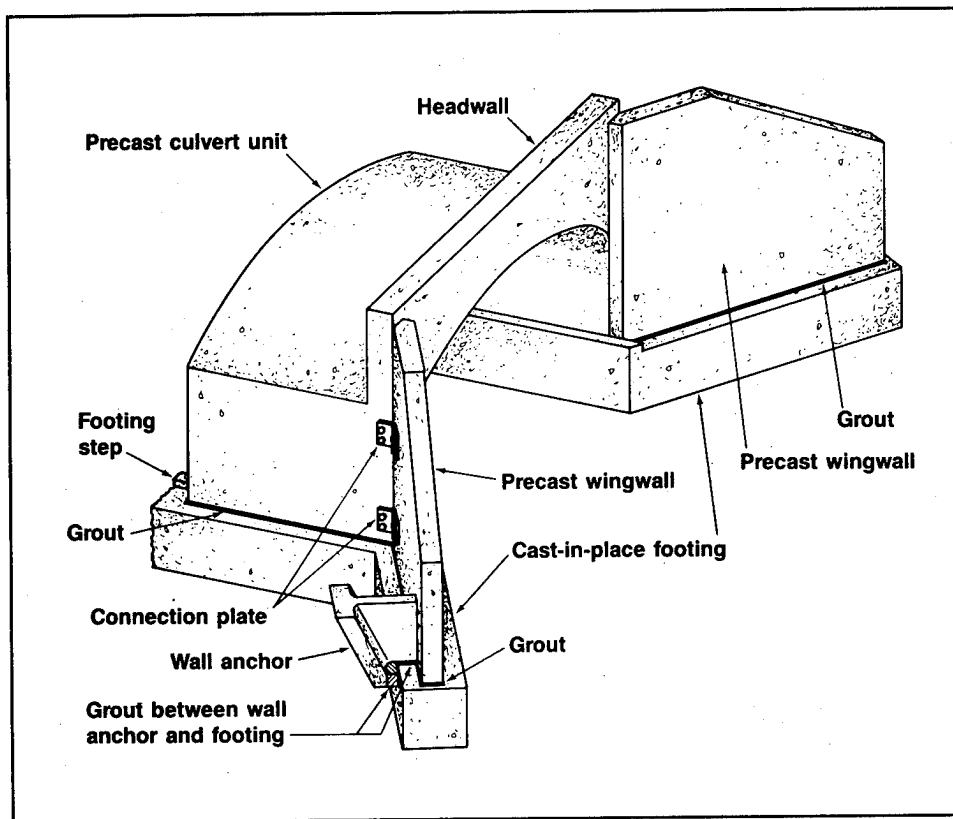

Figure 180. Plan of precast arch-box end section. Headwall is cast as part of the section; precast wingwall is attached during installation (from Hurd 1990)

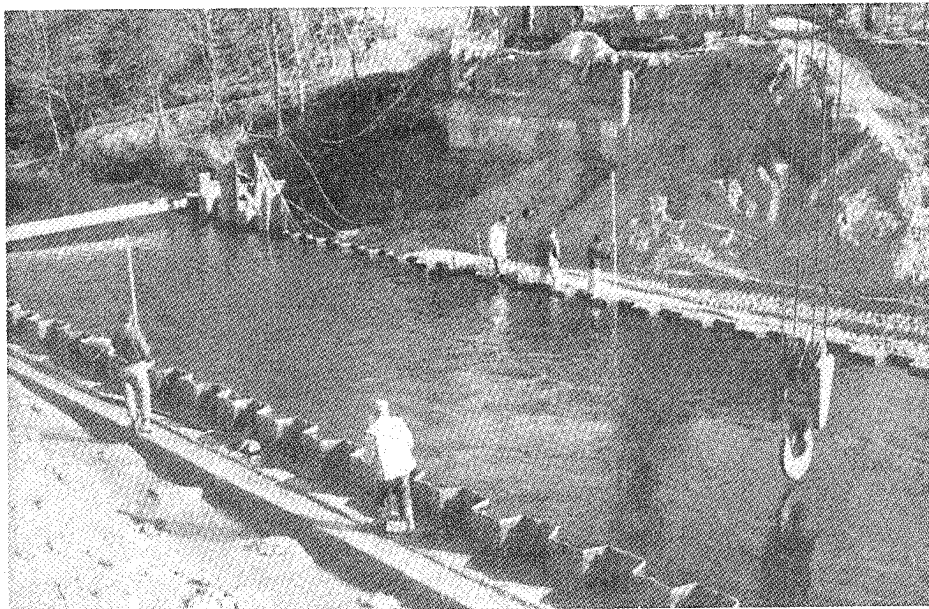

Figure 181. Cast-in-place footing with shims installed for Kent County bridge construction (from Hurd 1990)

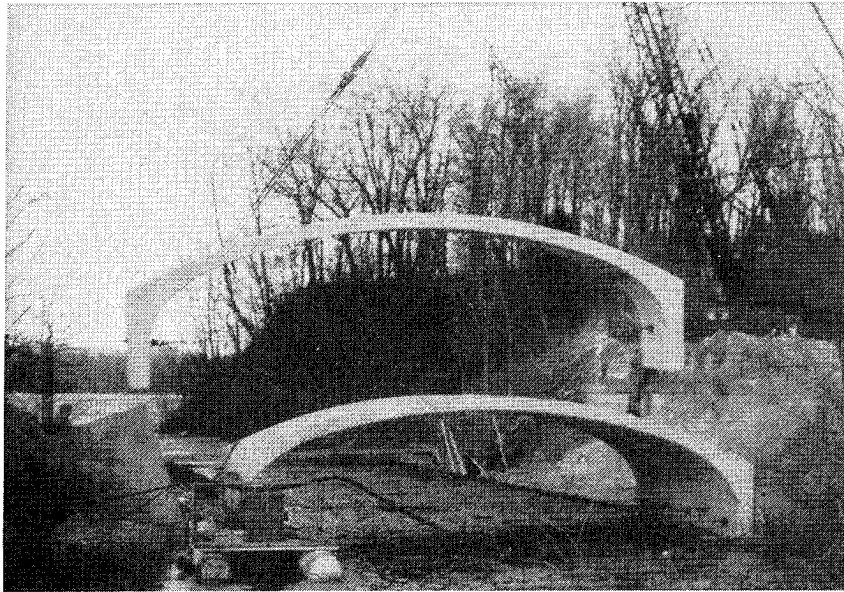

Figure 182. Precast arch-box units being placed at Kent County bridge (from Hurd 1990)

units. Once the units were aligned, each joint was covered with joint wrap (Figure 183), lift holes were plugged and sealed, and cable struts were removed. Then the precast concrete arch-box units were covered with 6 ft of backfill.

A less costly alternative to plant precasting is site precasting with inflatable forms and shotcrete. The inflatable forms are closed-end cylindrical balloons which are inflated at the jobsite and shaped with steel strapping.

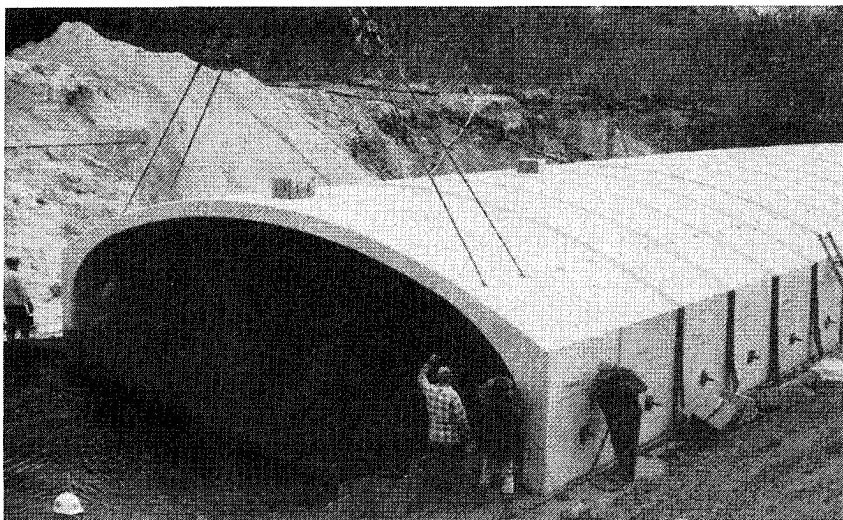

Figure 183. Joint wrap being applied to precast arch-box sections, Kent County (from Hurd 1990)

Once workers have achieved the specified size and shape with the inflatable forms, they set the reinforcing steel and place the shotcrete. A 6-in. thickness of shotcrete is sufficient for small-span arches, but as much as 10 in. has been applied in a single layer for larger arches. To ensure even placement of the shotcrete, crews place the shotcrete from both sides of the arch simultaneously, or a single nozzleman changes sides periodically during placement.

The forms are adjustable from a 4-ft to a 17-ft span and can be reused 40 to 50 times. For larger spans, two forms can be placed side by side (Figure 184).

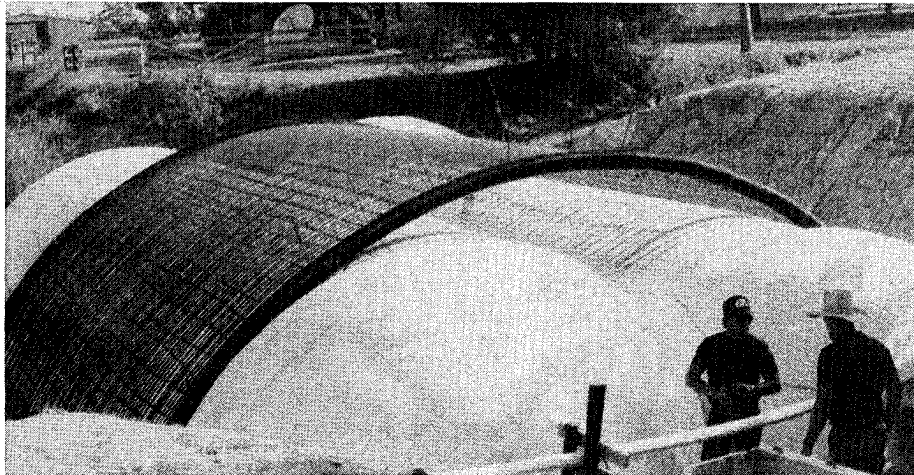

Figure 184. Steel reinforcing forms an arch over inflatable forms used for jobsite precasting arch sections for bridges (from Hurd 1990)

Pennsylvania Turnpike Median Barrier

The Susquehanna Bridge, which was built in 1953, is a part of the Pennsylvania Turnpike. The bridge originally had a 4-ft concrete island curb topped with a guard rail that served as a median. In 1983, the Pennsylvania Turnpike Commission began a \$2.4-million bridge rehabilitation program. As a part of the rehabilitation program, the Commission decided to replace the concrete island curb, which had proved to be unsatisfactory, with a median barrier. The project was described by Barnaby and Dikeou (1984).

Engineers investigated several repair alternatives, including in situ concrete, precast concrete, and precast polymer concrete. Factors affecting the final selection of a repair method included the amount of traffic on the bridge--approximately 20,000 vehicles per day--environmental factors such as rain, snow, and cycles of freezing and thawing, and the condition of the existing median. Cast-in-place concrete was ruled out as an option because it is not usually durable under the described conditions, plus it has a tendency to darken over time, making it difficult for drivers to see on dark, rainy nights. Precast concrete was not a viable option because of the difficulty involved in anchoring the precast barriers to the existing deteriorated median. The

Commission selected precast polymer concrete shells as the replacement option because the shells could be placed over new or existing reinforcement and because of the durability of polymer concrete.

Polymer concrete mixtures have high strength and high modulus, making them more impact resistant. Also, since water is not used in polymer concrete, the tiny voids left in conventional concrete when curing water evaporates are not present, thus increasing polymer concrete's resistance to cycles of freezing and thawing. The mixtures are also unaffected by road salts, acids, corrosive chemicals, and oils.

The median-barrier shells are 2 ft wide and were cast in 20-ft lengths to make transporting and handling them easier. The shells have pour holes on the top for placement of the superplasticized concrete filling and smooth, white surfaces (Figure 185). Before the shells were transported to the bridge site, the deteriorated curb island was removed. The shells were delivered to the jobsite on a trailer, 12 sections per load. A three-man crew unloaded the shells and placed them on the bridge. When a complete load had been placed, the same crew aligned them and anchored them to the roadway with 0.375-diam anchor bolts (Figure 186). Next, the shells were filled with 3,000-psi concrete, and polymer concrete plugs were set in the pour holes. The polymer concrete median barrier is four times stronger than a conventional concrete barrier. The 4,900-lin-ft barrier and one-half of the deck resurfacing were installed between July 1983 and September 1983.

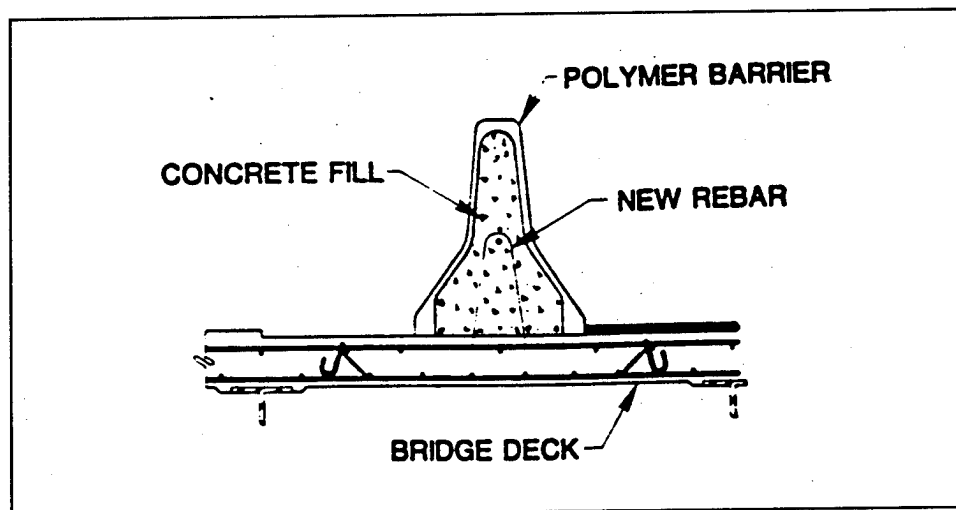

Figure 185. Cross section of precast concrete shell median barrier on Pennsylvania Turnpike (from Barnaby and Dikeou 1984)

Railroad Bridge Construction and Repair

Precast concrete was first used in construction of railroad bridges approximately 40 years ago, and since that time, its use has been steadily increasing.

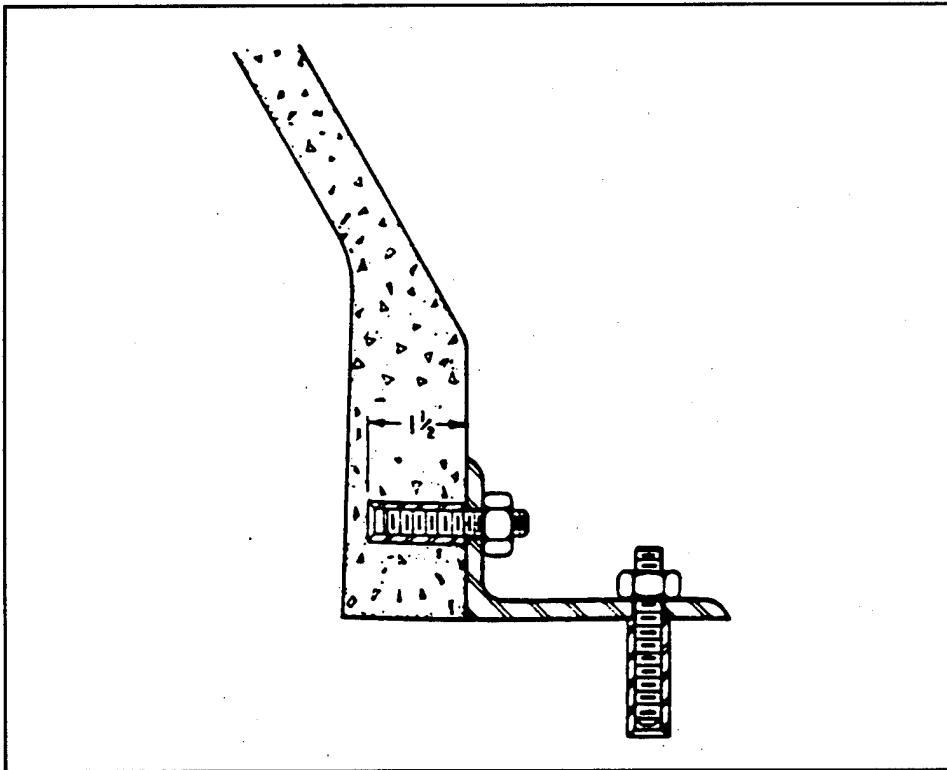

Figure 186. Cross section of anchoring system for precast concrete barrier shell on Pennsylvania Turnpike (from Barnaby and Dikeou 1984)

Within the last two decades, a number of railroad lines have developed standards for precast concrete mixtures, component designs, and quality control. Some railroad companies even stock precast components for emergency use. Marianos (1991) discussed the advantages and disadvantages of using precast components for railroad repair and construction.

Precast concrete offers several advantages:

- a. **Speed of construction.** Standardization of precast components saves time spent in project design and in construction. The only specification for replacement spans is length. Bridge crews work faster because they become familiar with precast components and construction procedures.
- b. **Durability of the completed structure.** The quality of the materials and the workmanship are easier to control in casting plants than onsite. Railroad engineers and precast suppliers can be sure components meet specifications before being shipped. Another plus for concrete is that it is not subject to damage from fire or corrosion.
- c. **Economy.** The estimated cost for 1 hr of train delay runs as high as \$400; closing one bridge can impact an entire system. Precast components enable engineers to make many repairs

between trains. (The remote locations of some railroad bridges would make the cost of cast-in-place repairs prohibitive.) Maintenance requirements for concrete components are low. Precast concrete is suited for construction of simple-span bridges, which are easier to build and maintain. And, with their supporting structure below track level, these bridges can more easily meet the requirements for wide cargo or double-stack containers in demand today.

Precast concrete has been used in the construction of a number of bridge parts, including piles, pile caps, girders, bolster blocks, bridge abutments, and ballast troughs (Figures 187 and 188). It has also been used for auxiliary structures, such as culverts, retaining walls, and snow sheds.

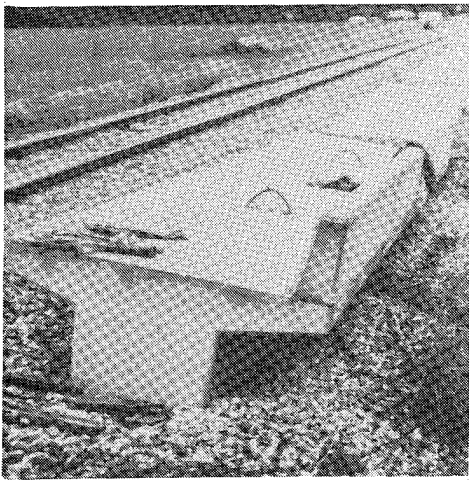

Figure 187. Precast, reinforced-concrete T-girder stored beside track until needed (from Marianos 1991)

Although several Class I railroads (those with annual revenues in excess of \$93 million) use precast, prestressed concrete piles, many lines do not because of the difficulty of installing them with track-mounted pile drivers. However, they are preferred for use in marine or corrosive locations.

Concrete pile caps can be cast to accommodate steel or concrete piles and timber stringers. Those for use with steel piles have a steel plate embedded along the bottom of the cap so the cap and pile can be welded together. Those to be used with precast concrete piles are cast with a void into which the pile fits. After they are installed, the cap and pile are grouted together.

Abutment walls used to support a bridge are precast in sections and then bolted together onsite.

Bridge spans range from 14 to 80 plus ft. Spans from 20 to 30 ft are predominantly T-girders, I-girders, or box girders. Spans between 30 and 45 ft are primarily box girders. Those over 45 ft usually consist of four single-void box girders tied together with epoxied shear keys and steel rods (Figure 189). Smaller units are used to avoid the weight of the longer spans and the difficulty of installing them with track-mounted equipment, which usually has limited lifting capacity and reach.

Precast concrete is not without some problems. Weight is the primary disadvantage. Other problems have been caused by cycles of freezing and thawing and differential settlement of pile caps. Also, it is difficult to repair precast spans, especially under time restraints. Usually, it is easier and quicker to replace the span than to repair it. Increasing the strength of precast components so they can carry heavier loads is also more difficult than strengthening components made of other materials.

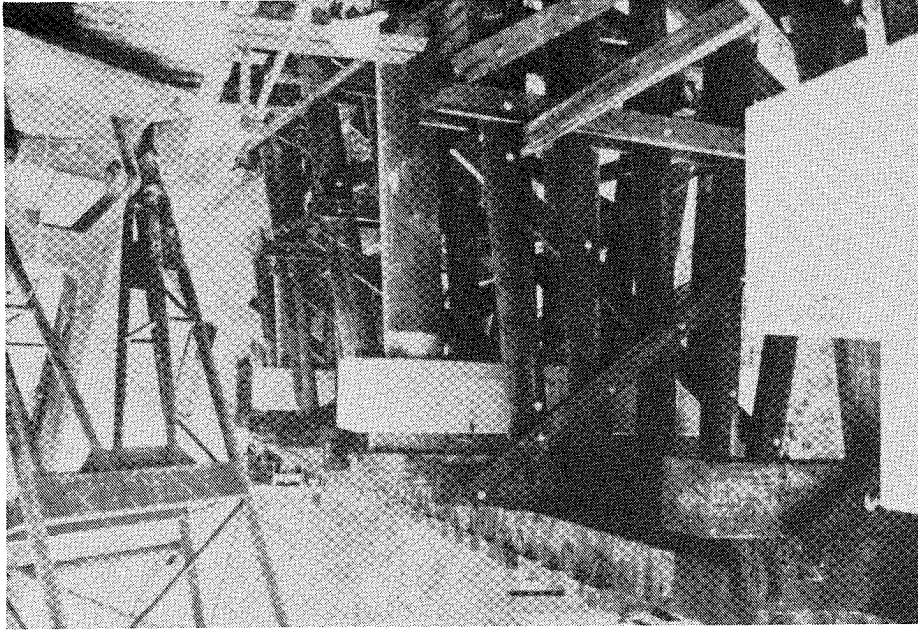

Figure 188. Precast concrete pile caps for replacement spans beneath timber trestle (from Marianos 1991)



Figure 189. Shear keys between box girders are filled with pea gravel and epoxy (from Marianos 1991)

Even so, the use of precast concrete to construct and repair railroad bridges is expected to increase because its benefits outweigh its disadvantages, and railroad use is increasing. In the past 10 years, American railroads have spent approximately \$30 billion improving tracks, structures, and equipment.

The Santa Fe Railroad System

The Santa Fe Railroad system used precast concrete units to replace all bridge decking constructed of timber on steel girders. Hyma (1979) described the rehabilitation; his report is summarized here.

Approximately 32 out of 220 miles of bridges located throughout the 12,000 miles of track in the system were timber decking on steel girders. Built between the late 1890s and early 1900s as open-deck bridges, they were converted to ballasted decks about 20 years later. Although ballasted decks reduce track maintenance, moisture seeping through the ballast causes extensive corrosion of the top flange of the girders and the top lateral bracing system of the spans (Figure 190). These components usually stay moist but are located too near the deck to be reached for cleaning and painting. In addition, water draining from the ballast and the poor ventilation inside the span cause the paint on other surfaces to break down rapidly.



Figure 190. Corrosion of the top flange of a girder on the Santa Fe Railroad (from Hyma 1979)

Epoxy-grouted, precast, prestressed concrete slabs were selected as the deck replacement method because it eliminated the need to replace the corroded lateral bracing systems and provided a watertight surface, which protects the steel and the painted areas. Bonding the concrete slabs to the steel girders strengthened the spans, so cover plates will not have to be replaced often. Stress tests were conducted with SR4 strain gages both before and after installation of the precast concrete slabs. The results showed a 50-percent reduction in stress for the top flanges and 11 percent for the bottom, even with the additional weight of the concrete. Sealing the transverse joints between slabs with epoxy grout created a watertight, monolithic deck.

The deck slabs were cast by a commercial prestressing plant located near the railroad in Albuquerque, NM. From there they could be shipped throughout the system. Designed for Cooper's E80 loading, each slab measured 8 ft by 14 ft by 8 in. thick. One-half-inch-diameter, high-strength steel strands

were pulled through the length of the casting forms for prestensioning (Figure 191). Steel reinforcing was tied to the strands near the bottom of the casting form to create a surface with maximum water resistance (Figure 192). Another mat of reinforcing was placed near the top surface. Threaded inserts for the top flanges of the girders and curb and walkway fastenings were bolted to the forms, and the handling loops were tied in place.

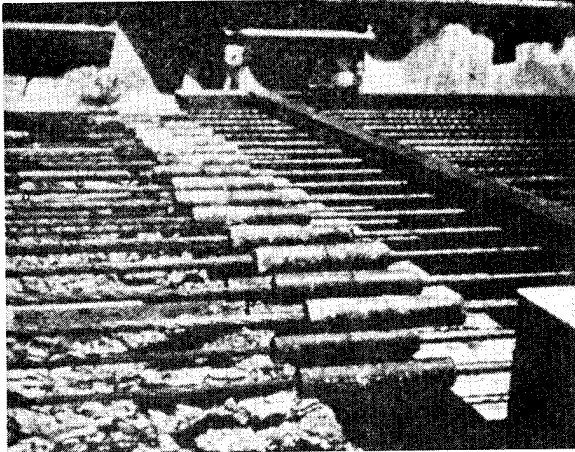

Figure 191. High-strength strands are pulled the length of the casting bed and tensioned with a hydraulic jacking system (from Hyma 1979)

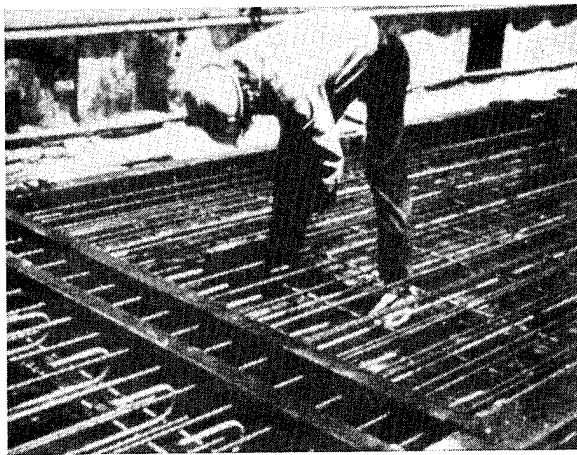

Figure 192. A bottom mat of mild steel reinforcing is tied to the strands of the Santa Fe Railroad (from Hyma 1979)

The slabs were cast with air-entrained concrete with a compressive strength of 4,000 psi at transfer of prestressing force and 5,000 psi at 28 days. The exposed surface was rough-boom finished to improve the bond with the epoxy grout placed on the girders. Following initial set, the slabs were covered with

rubberized tarps and steam cured overnight. A locomotive crane was used to handle the 6-ton, precast slabs, which were delivered to the jobsite on flat cars.

Preparatory work included removing the track, ballast, and old deck, cleaning the girders to white metal by sandblasting, and bonding thin strips of 5/8-in. plywood along the edges of the top cover plate with epoxy gel. This surface was then covered with a layer of silica sand-epoxy grout to the level of the rivet heads projecting above the cover plates. In order that the contact surface be fully bonded, enough grout was used that the weight of the slab caused some of it to flow out. The epoxies, all of which were moisture compatible, were placed in 5 gal pails with the dry sand and then mixed with electric-powered mortar mixers. The set-up time for the epoxy varied with the temperature; the average time during summer months was about 4 hr.

When the slabs were placed, the traverse joints were tight at the bottom but opened about 1/4 in. at the top. The epoxy gel sealed the area from the bottom, and the next day, the sand-epoxy grout was poured into the joints (Figure 193).



Figure 193. Sand-epoxy grout was used to fill traverse joints between the slabs on the Santa Fe Railroad redecking (from Hyma 1979)

After the precast concrete slabs were placed and grouted, the ballast curbs, rail ties, rails, and ballast were replaced, and the track was ready for traffic. Material costs for the precast concrete, epoxy-bonded system were about 25 percent higher than timber replacement would have been. Labor costs varied but were approximately equal to the estimated cost for timber replacement. The savings will be realized in the low maintenance of the precast concrete deck.

The same basic installation plan was used for all of the bridges; the only variation was caused by the difference between work on a single-track or a double-track bridge. All work had to be done within a set block of time in order to keep trains on schedule. When a replacement was being made on a

single-track bridge, the section lengths were determined by the number of units that could be placed within the block of time scheduled for that day.

The Southern Pacific Railroad

When the truss spans on a 90-year-old railroad bridge had to be replaced, the Southern Pacific Railroad system decided to replace the entire structure. Precast concrete was selected as the replacement method. Marianos (1991) described the rehabilitation. This case study is a summary of his report.

The bridge consisted of a 90-ft timber trestle approach, two 154-ft through-truss spans, and a 30-ft steel-plate girder span. The first step in the project was to construct the substructure. Steel H-piles were installed in the timber trestle area with a track-mounted pile driver. The piles, spaced to provide 30-ft span lengths, were cut off at the specified height, capped with precast concrete pile caps, and welded to the steel plates embedded in the bottoms of the caps.

Four intermediate piers were used to support the truss spans. Each pier consisted of a 79-ft precast, prestressed box girder placed on piles driven through the existing floor system (Figure 194). The 79-ft box girders were longer than the span range of railroad standards, so girders for this project had to be designed.

Upon completion of the substructure, replacement of the approach spans began. Both the timber trestle and the steel-plate girder span were replaced with 30-ft precast box girder spans. Two 30-ft sections were placed side by side for each span in the timber trestle area. The box girders were cast with two through-voids and an integral ballast retaining sidewall-walkway on the outside edge. A shear key was placed between the two girders to ensure load distribution. Engineers raised the precast box girder spans to the correct elevation by placing precast concrete bolster blocks on the existing masonry piers (Figure 195). After the steel trusses were removed and the truss attachments were replaced with elastomeric bearing pads, the box girders were lifted into place. Each steel truss was replaced by two spans, each span consisting of four box girders.

While the longitudinal joints and shear keys between these girders were epoxied, the second span of girders was placed. These spans were epoxied and handrail cables were strung along the walkways. Then, prefabricated railroad track panels were placed on the spans. Once the ballast was placed and tamped and the track reconnected, the new spans were ready for traffic.

Replacement of the first 154-ft truss span required a 12-hr track closure. The second truss span was replaced several weeks later.

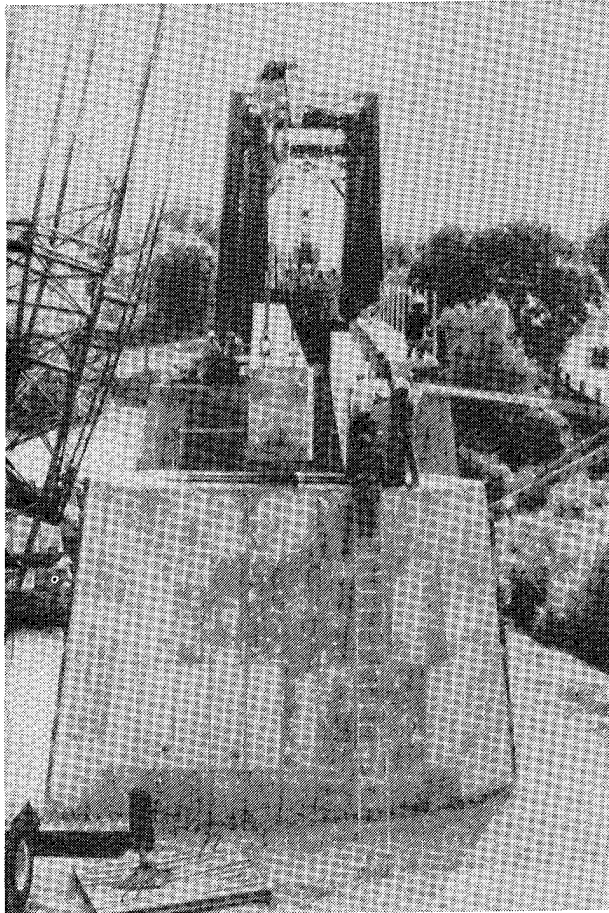

Figure 194. Interior box girders placed on piers during Southern Pacific bridge replacement (from Marianos 1991)

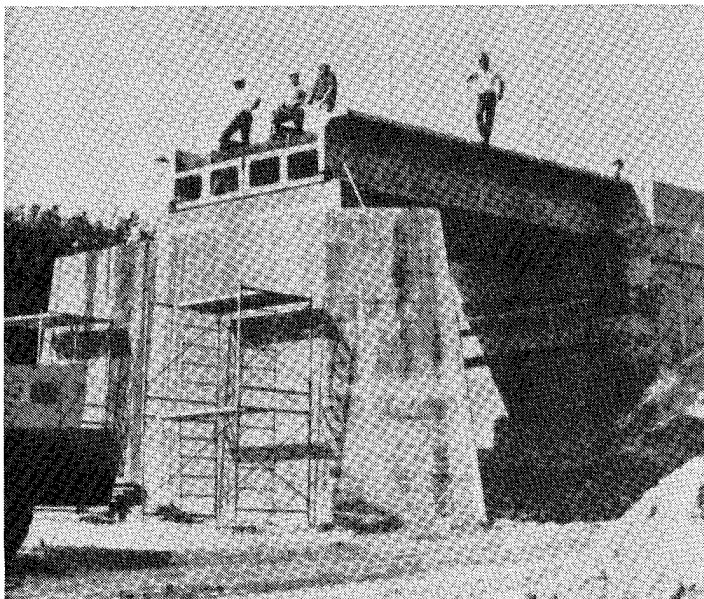

Figure 195. Precast 30-ft box girder approach span on precast bolster blocks, Southern Pacific Railroad (from Marianos 1991)

Culverts and Tunnels

Minnesota

The design for precast concrete box culverts installed in Minnesota is a modification of ASTM C 789 (1978). The design (Figure 196) was created with a computer program developed by the American Concrete Pipe Association. The boxes were cast in 5-ft lengths and joined by tongue and groove joints sealed with 1-in.-diam preformed mastic. Advantages of the precast culverts are that they can be installed in a short amount of time, they are easy to add on to, and they can be moved from one place to another should the need arise (American Association of State Highway and Transportation Officials (AASHTO) 1978).

Fort Sill Army Base

The U.S. Army Corps of Engineers used precast reinforced-concrete boxes (RCB) to reconstruct the intersection at Moway and McKenzie Hill Road, Fort Sill Army Base, OK. Time was the primary factor in the decision to use RCB. The contractor estimated that using RCBs would reduce construction time by a month. The RCBs were constructed according to ASTM C 789 (1989). Each box measured 8 by 8 by 6 ft and weighed approximately 10-1/2 tons. The 46 RCBs required for the intersection were placed in 2-1/2 days. For this project, a special mixture of cement, sand, and fly ash was used as backfill. Because of the high slump of the mixture, there was no

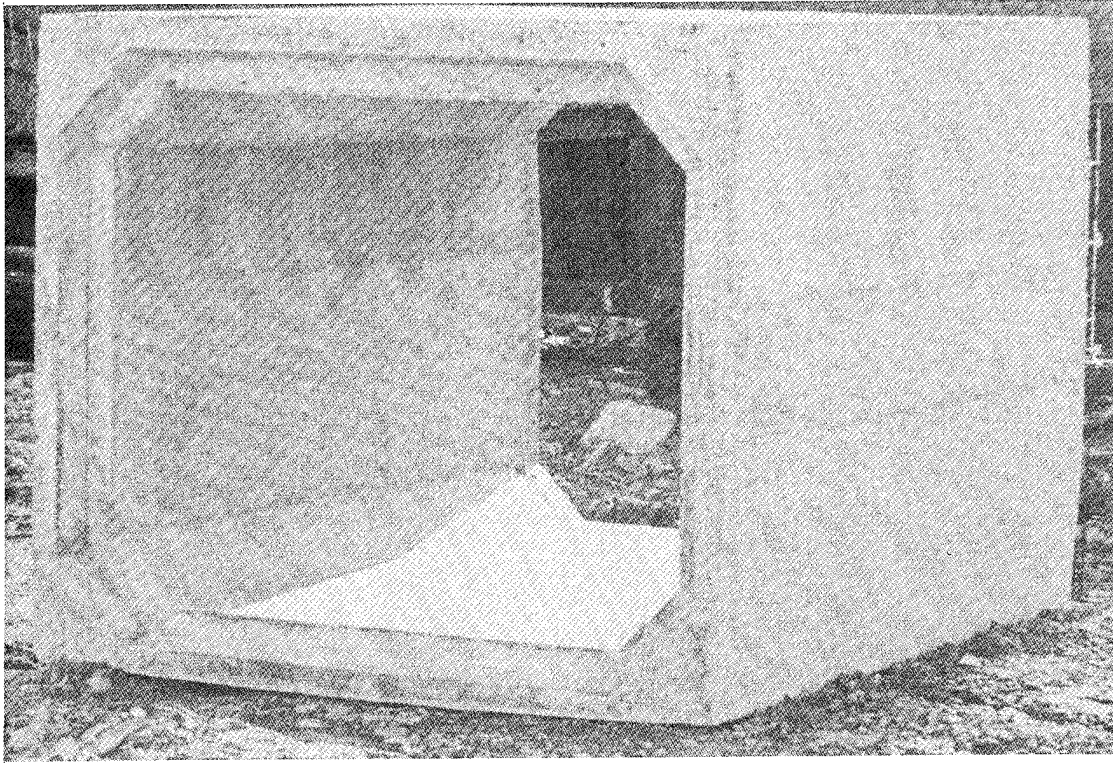

Figure 196. Precast concrete box culvert, Minnesota (from AASHTO 1978)

need for packing; the fill flowed into corners and joints. Not only was this mixture easy to place, but it also helped stabilize the structure. Backfilling the structure required only 3 hr (*Construction News* 1990).

North Dakota

The North Dakota DOT called for construction bids for replacement of two failing corrugated metal pipe arches on State Highway 21 about 5 miles west of Mott. The contractor had the option of either a cast-in-place box or a precast box culvert. He elected the precast method because it would require less construction time, an important consideration because of the unpredictability of weather during the fall, and would make maintenance of the detour easier. The double-cell box culverts were cast in 6-ft sections, each 12 by 9 ft. Excluding site preparation, the culverts for the 126-ft line were installed in only 2 days. A 2-ft-wide band of filter fabric was placed over the joints to reduce silt penetration, and each outside wall was posttensioned to 15,000 lb to ensure stability. The day after the project was completed, 16 in. of snow fell in the area. A snow this deep would have stopped construction, so the precast option proved to be the right one (Hagen 1992).

New Jersey

South Orange Avenue runs through South Mountain Reservation parkland in Maplewood, Millburn, and South Orange, NJ. Traffic on the roadway averages approximately 22,000 vehicles per day (vpd). The section of the avenue that crosses the West Branch of the Rahway River was supported by a double-barrel, earth-filled brick arch culvert that was installed around 1900. When bridge inspectors discovered deterioration of the concrete in the culvert, Essex County officials decided to make temporary repairs; traffic was reduced to one lane in each direction while repairs were being made. Vitale and Siebold (1992) described the precast installation; their report is summarized here.

Later, the officials decided to replace the culvert rather than just repair it. They contracted with a construction company to develop a replacement plan that would be cost-effective and that would minimize disruption of traffic, the parkland, and the freshwater wetlands.

Rather than construct a detour road, which would impact upon the parkland, the contractor determined to use existing roads to carry traffic. The route selected for the detour passed through four municipalities and several residential neighborhoods. To minimize the disruption to all concerned, the contractor agreed to limit use of the detour to 14 consecutive days and to pay a penalty for every day he ran over schedule. To meet the schedule, the contractor opted to use precast sections to construct the entire replacement culvert.

The contractor used a twin precast concrete culvert with basic waterway openings. The inside dimensions of the culvert are 20 ft wide by 4 ft high by 68 ft long. The end sections and wingwalls were cast-in-place with reinforced concrete. As each section of the culvert was constructed, the contractor installed necessary shoring so traffic could use one lane in each direction in the new culvert area; therefore, the avenue was completely closed for only two weeks. When the replacement culvert was in place, rubble stone was added as a facing to provide an appearance more in keeping for a culvert located in a parkland.

In addition to minimizing disruption to the public and protecting the parkland, use of the precast culvert saved county taxpayers a minimum of \$250,000.

Kentucky

The Kentucky DOT used precast concrete units to replace an old, 15-ft-span, concrete culvert at the Route 8 exit off I-471. Each unit was 8 ft wide with a span of 20 ft and a rise of 14 ft. The precast units were placed on a 4-1/2-ft cast-in-place pedestal wall. Since the exit ramp was kept open, a temporary sheetpiling system was installed to support the roadway. Then the foundation and pedestal walls were poured. The precast units, each weighing

about 20 tons, were transported to the site by truck and placed with a crane. Approximately 22 ft of fill was used to cover the units. The total cost of the 328-ft culvert was about \$682,000; the precast units, including installation, were \$197,000 (ASCE 1989).

Vancouver, B.C.

In January 1991, the Engineering Department of Delta, Vancouver, B.C., replaced a failed metal culvert with a precast box culvert. The 20-year-old metal culvert collapsed during a period of heavy rainfall, leaving a channel 33 ft wide and 20 ft deep. The next day, a nearby construction supplier provided five sections of culvert from a stockpile that had been manufactured for another project. Each box measured 8 ft by 5 ft by 8 ft 2 in. The boxes were placed on crushed gravel; the joints were wrapped with filter cloth, and the structure was covered with 6-1/2 ft of backfill. The service life of the concrete culvert is expected to be much greater than that of the metal culvert (Pope 1991).

New York State Thruway

Metal culverts placed under the New York State Thruway in 1953 were inspected in August 1990. The inspection revealed severe deterioration of a 60-in., 282-ft multiplate culvert under 120 ft of cover near Nyack and a 60-in., 528-ft corrugated metal and multiplate pipe under 105 ft of cover in Monsey (*Public Works* 1993).

The culvert near Nyack was deformed at the inlet, and some of the joints had separated. A 2-ft area of corrosion at the invert had resulted in erosion beneath the culvert. The head wall at the end of the culvert was cracked, and a section of the wingwall had fallen.

Tree trunks and debris blocked the inlet of the culvert near Monsey, resulting in some flooding. This culvert had also lost its shape and had become ineffective.

Instead of replacing the metal culverts, the New York Department of Transportation (NYDOT) decided to rehabilitate them with precast concrete pipe. Calculations based on a 100-year flood were used to determine the size pipe required.

After debris had been removed from the culverts, a pair of steel channels were tack welded to the bottoms of the culverts. These channels served as a track for the concrete pipes, which were pulled into the metal culverts rather than jacked into them. A winch and a system of pulleys and cables were used to pull the 42-in.-diam pipes, section at a time, into the culverts. Once the pipes were in place, concrete mortar was pumped into the space between the pipes and the metal culverts to solidify the structure. The head wall at Nyack

was rebuilt. The rehabilitated culverts are expected to last from 60 to 100 years.

Advantages of this installation procedure over jacking are (a) reduction of the pressure load on the last sections of pipe (the force required to pull a pipe is less than the weight of the pipe itself), (b) pulling does not require building a structure to work against, and (c) pulling through a culvert's bends and inclines is easier than jacking through them.

Holland Tunnel

The Holland Tunnel, which passes under the Hudson River, was constructed in the 1920s to connect New York City and New Jersey. In the mid-1980s, an inspection revealed serious deterioration of the concrete in the ceiling of both tubes of the tunnel. The method chosen to repair the ceilings was precast concrete ceiling panels. The repair described by Monti and Eglot (1986) is summarized here.

The precast-panel method was chosen over cast-in-place because it required less time, made working around traffic demands possible, and reduced field labor costs. Repair was scheduled to be done in one tube at a time with most of the work done at night so traffic operations could resume during the day.

Concrete specifications for the precast panels called for a dense concrete with a low water-cement ratio and superplasticizers. White, glazed ceramic tiles, which would increase the reflectivity of the ceiling and facilitate cleaning, were installed on the panels at the plant. A minimum adhesion of 60 psi was specified for the grout used to bond the tiles to the concrete; the contractor added latex to the cement grout, doubling its adhesion and reducing its permeability, making it more impregnable to chloride and sulfate ions which could cause deterioration of the concrete over time.

The precast panels were designed for a dapped-end theory installation (Figure 197). Vertical reinforcing bars were installed at the edge of the panels with the reinforcing extending through the tops of the panels to form loops. During installation, hooked bars inserted through the loops and tied to the panels were keyed into the vertical concrete walls of the tunnel with a cast-in-place end segment. To ensure the integrity of this application of the dapped-end theory, the contractor conducted full-scale preconstruction tests. The panels did not show signs of failure until the test load reached 400 lb/sq ft.

Most of the old ceiling was removed with a jackhammer, but a saw was used at the ceiling-lining interface. After the sections had been saw cut, the concrete was chipped away to expose a cold construction joint, thus forming a keyway to be used as part of the dapped-end connection. Also, the concrete around the original hangers and the transverse tierods was cut and chipped away as these components were used in the new construction. During panel

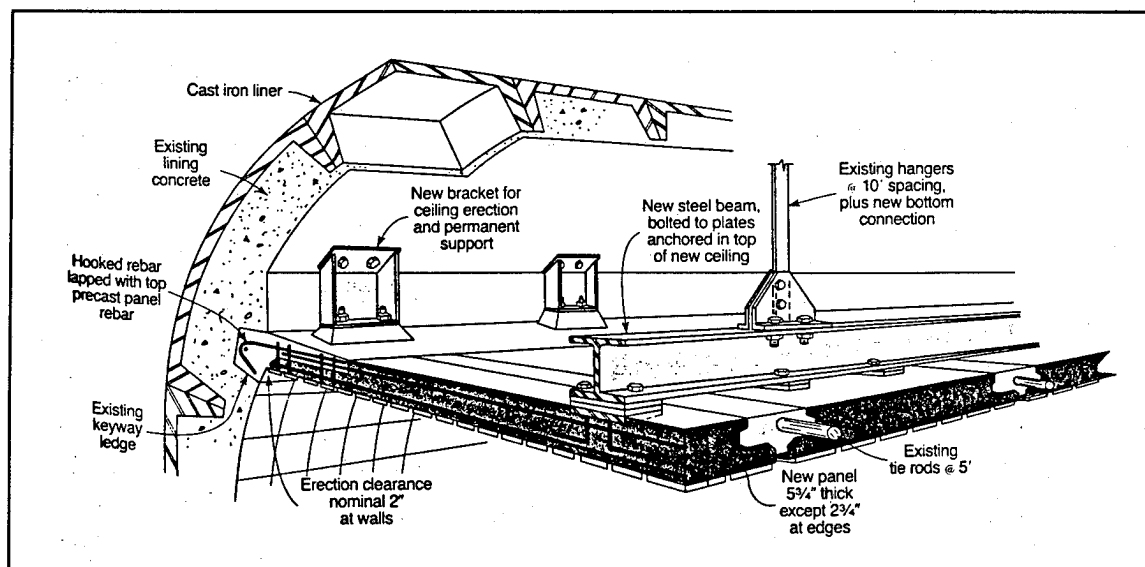

Figure 197. Ceiling replacement design for Holland Tunnel (from Monti and Eglot 1986)

installation, the tierods, which linked the tunnel walls, were protected with cardboard tubing filled with a fireproofing material.

St. Hubert Tunnel

A precast concrete arch tunnel system (Figure 198), patented by Matiere S.A., Paris, was installed in a park in St. Hubert, Quebec, Canada, in August 1992. The tunnel, part of St. Hubert's \$300-million urban transformation project, is 100 ft long and has a 33-ft span. The tunnel consists of longitudinal ring segments. A crane was used to place the self-stabilizing segments into a trench filled with bedding. Reinforcing bars that extended across the joints were covered with adhesive polyethylene and bitumen tape. The tunnel, which opens on a man-made lake used for recreation, was completed with a roadway over it and bicycle paths on either side (ASCE 1992).

One of the major advantages of the system is the short time required for construction. Four workers, including the crane operator, completed the tunnel in six 8-hr shifts.

Twelve countries, excluding the United States, have used this tunnel system in over 2,500 installations. Tunnel segments are usually 8 ft deep and can be up to 55 ft wide. The concrete in the segments can be 7, 8.75, or 10 in. thick. The structures, which have been installed as deep as 45 ft, conform to the terrain.

The system was used to build a precast, double-arch tunnel in Malaga, Spain. Completed in April 1992, the 1,400-ft-long tunnel, and each of its 55-ft-wide bays, carries three lanes of traffic. After construction had begun, an additional section was added to provide another lane for traffic to exit.

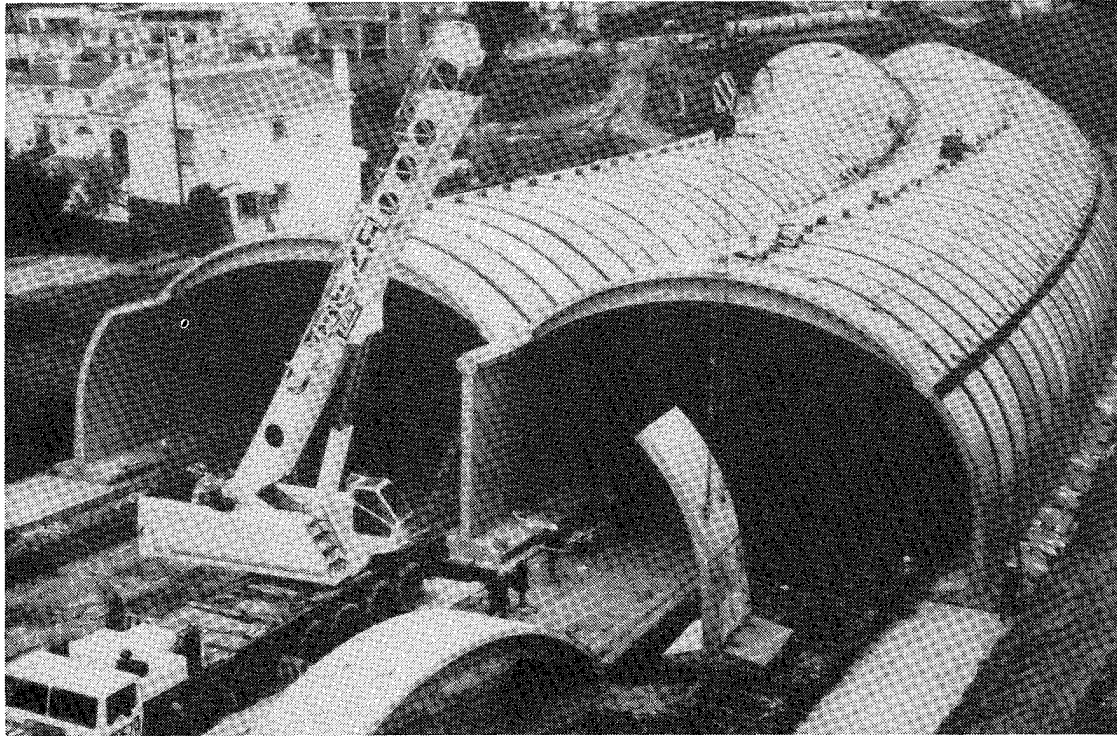

Figure 198. Double arch tunnel system to be used in St. Hubert Tunnel (from ASCE 1992)

The approximate cost, including design, fabrication, waterproofing and installation, was \$4.5 million, 17 percent less than a cast-in-place system with precast beams or a totally precast structure. The Malaga tunnel required only 4 months to build; estimated time for the other systems was at least 8 months.

Sumner Tunnel

When Sumner Tunnel was constructed in 1934, the bench walls of the tunnel were constructed with concrete, which was then painted. During the early 1960s, the bench walls were covered with ceramic tiles, which over time began to fall off as a result of traffic accidents and deterioration of concrete and mortar. About 1970, approximately 40 percent of the bench walls were reconstructed with concrete panels and ceramic tiles. In January 1982, tunnel authorities decided to replace the bench walls with a more durable, aesthetic surface. Project engineers investigated several repair methods (Barnaby and Dikeou 1984).

Among the alternatives considered were precast concrete panels, galvanized steel panels, and precast polymer-concrete panels. Precast concrete was eliminated as an option because the panels would have been difficult to handle in the limited work space, a large amount of existing concrete would have to be removed for the panels to be placed, and the panels would have extended too far into the roadway. Concern over the susceptibility of galvanized steel to the caustic conditions in the tunnel caused it to be rejected also. The choice

for the repair was precast polymer-concrete panels as stay-in-place forms (Figure 199).

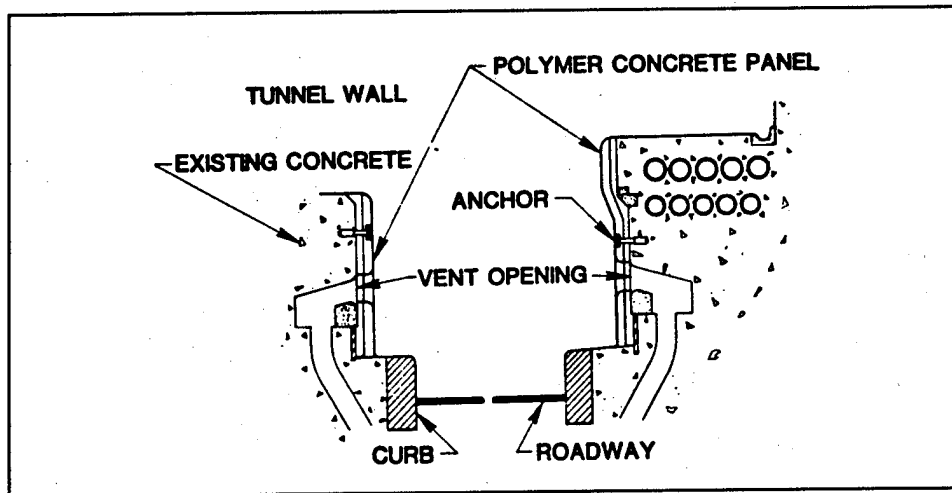

Figure 199. Cross section of plan for rehabilitation of Sumner Tunnel, Boston (from Barnaby and Dikeou 1984)

The polymer concrete offered several advantages. Because of its unusually high compressive strength and a high modulus of elasticity, it can be used to cast panels that are thinner and, therefore, lighter than those cast with conventional concrete. Also, polymer concrete mixtures do not use water so they do not develop the tiny voids left in conventional concrete when the curing water dries. The absence of voids makes polymer concrete more resistant to cycles of freezing and thawing than conventional concrete.

The polymer-concrete mixture used to cast the panels for Sumner Tunnel had a compressive strength of 15,000 psi. In addition, the panels were reinforced with fiberglass, making them even more resistant to impact, salts, corrosive acids, and chemicals. The 3- by 15-ft panels have a smooth white surface that matches the existing tunnel lining and increases illumination. They were cast with vent openings that match existing air vents and with installation anchors.

Construction was done between midnight and 5:30 a.m. so both lanes of the tunnel could be kept open during the day. The number of panels that could be placed during a single shift was brought into the tunnel on a flatbed trailer equipped with a boom for lifting and placing the panels. Panels were positioned so the cast-in anchors fit into predrilled holes in the sidewall. When all of the panels were unloaded, workers completed final alignment and anchoring (Figure 200). Vent openings were sealed before the backfill concrete, a modified mixture with a superplasticizer, was placed. After the backfill concrete was placed, vertical joints were sealed, and the anchor holes plugged with a special plastic plug that created a smooth surface. Twelve men installed approximately 36 panels per shift.

Cost of the project was approximately \$1.2 million.

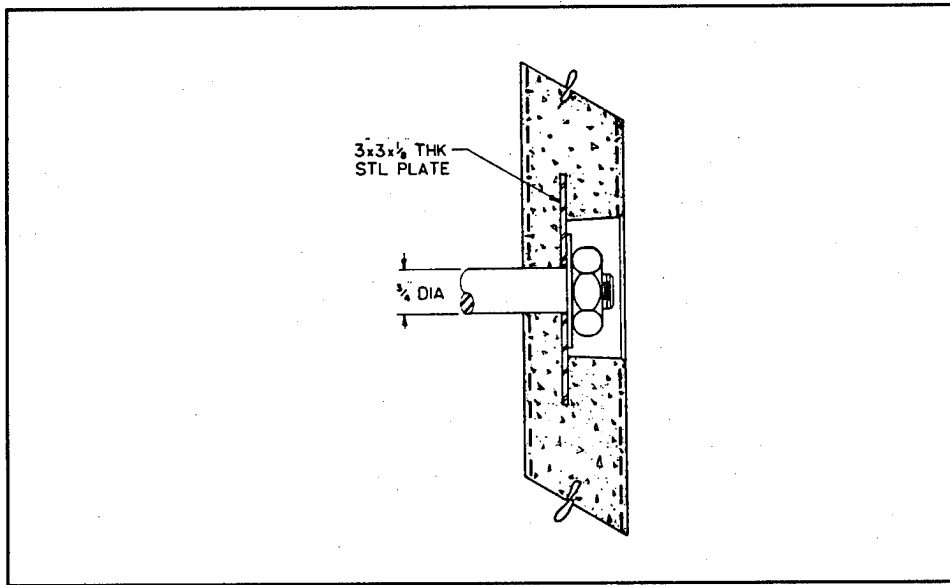

Figure 200. Details of anchoring system for precast polymer concrete panels used in Sumner Tunnel, Boston (from Barnaby and Dikeou 1984).

Callahan Tunnel

Boston's Callahan Tunnel is undergoing a refurbishing which will include repair and modernization. The deteriorated sidewalls of the tunnel are being repaired, and the lighting and electrical systems are being modernized. This case study is a summary of a report by Doug Barnaby (1993).

Because of the favorable performance of polymer-concrete panels installed in Sumner Tunnel in 1982, polymer concrete has been selected for the rehabilitation of Callahan Tunnel. Polymer concrete uses resin, rather than cement, as a binder for a mixture of coarse and fine aggregates. Because of the exceptional bond between the resin and the aggregates, it develops strengths three to five times those of conventional cement concrete. Higher strength means structures can be built of thinner, lighter components than those made with steel, conventional concrete, or wood. Unlike conventional concrete, which is filled with minute voids when cure water evaporates, polymer concrete forms an impervious barrier that is resistant to deicing chemicals, cycles of freezing and thawing, and other causes of deterioration.

The precast polymer-concrete panels will be used as cladding for the deteriorated sidewalls. The panels are 1-1/2-in. thick and have a 40-mil, white gel-coat surface that is fused to the panels during casting. The surface makes them highly reflective, much like ceramic tile. The bench walls are being removed and restructured to provide space for conduits for the increased electrical and lighting systems. The polymer panels will serve as stay-in-place forms for the new bench walls.

The hard polymer finish is expected to retain its color and to be resistant to detergent washing, brushes, high-pressure water jets, and deicing salts.

Retaining Walls and Noise Barriers

Precast concrete panels are an expedient and cost-effective means for building retaining walls. Not only can they be erected in a short period of time, but many of them can be disassembled and reused. The Indianapolis Power & Light Company used precast concrete panels to rehabilitate their coal storage facility, and a Massachusetts contractor used precast concrete panels cast with a stability brace to build a retaining wall around a shopping center under construction.

The need for acoustic barriers for roadways is increasing as suburban areas continue to extend out from cities. These areas create traffic congestion, which is relieved only by construction of freeways through these residential sections. The freeways become sources of vehicular noise that often exceeds the "acceptable" level. Acoustic barriers have become the solution to this type of "noise" problem. Vorobieff (1991) classified and described several types of acoustic barriers for roadways; his report is summarized here.

Acoustic barriers are classified as reflective, dispersive, or absorptive. Reflective barriers (Figure 201) are usually constructed at the edge of the road. Although some noise comes through the barrier, most of the sound is reflected back to the traffic lanes, possibly increasing the noise level for those in the vehicles. This type of wall is usually higher than the other types. Dispersive barriers dissipate noise by reflecting it upwards or downwards, according to the design of the wall (Figure 202). The dispersive barrier is regarded by most designers as a modification of the reflective barrier. Absorptive barriers control sound by obstructing its movement with tiny fibers or numerous passages that shape the surface of the wall; therefore, they "absorb" the sound by dissipating it (Figure 203). An absorptive material can be applied to a concrete wall to create an absorptive acoustic barrier (Figure 204). These barriers are not recommended for use in very wide traffic areas.

The primary criterion used in the selection of an acoustic barrier is the effectiveness of the structure. Other important considerations are construction cost and the construction site. Finally, the appearance of the acoustic barrier is important since so many of these structures are located in residential areas. Precast concrete is a viable method for building acoustic barriers because it is cost-competitive with other materials. In addition, precast concrete acoustic barriers are durable (their life expectancy is a minimum of 40 years), they require little maintenance, and their surfaces can be finished in a variety of ways that make them aesthetically suited to their setting.

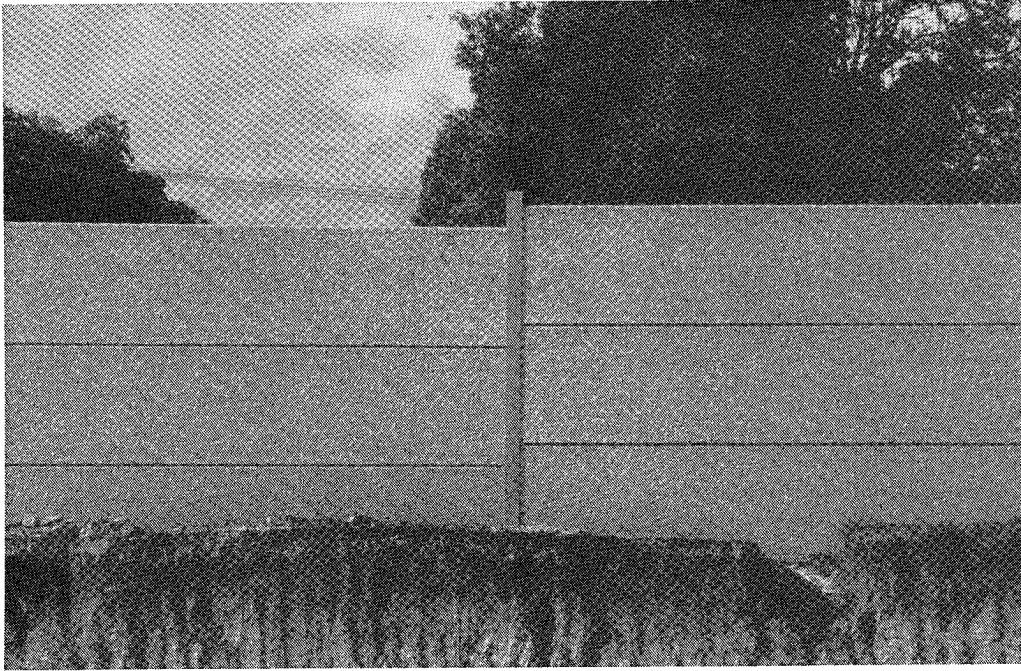

Figure 201. A reflective acoustic barrier made of Hollowcore planks (from Vorobieff 1991)

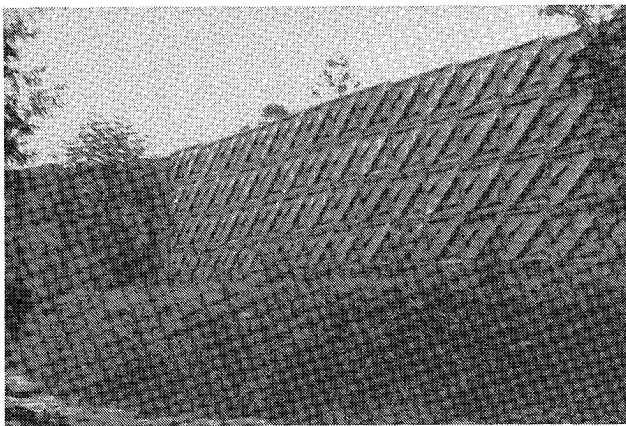

Figure 202. A dispersive acoustic barrier (from Vorobieff 1991)

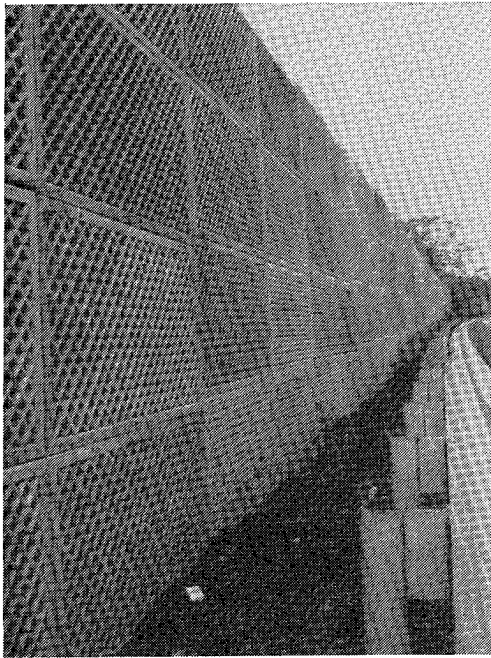

Figure 203. An absorptive acoustic barrier (from Vorobieff 1991)

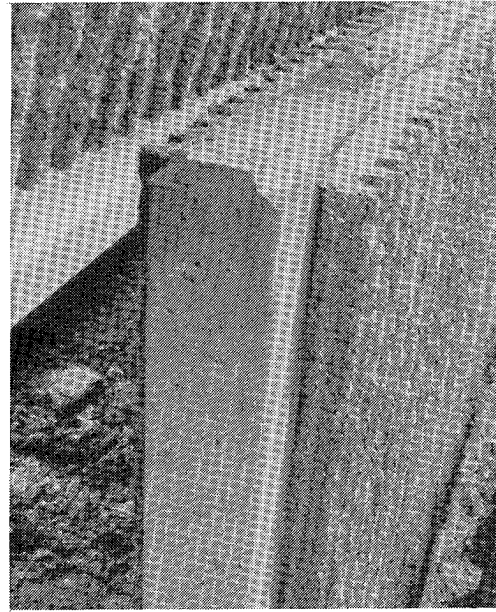

Figure 204. Precast concrete wall covered with absorptive material to create an absorptive acoustic barrier (from Vorobieff 1991)

Indianapolis Power & Light Company Coal Storage Facility

The Indianapolis Power & Light Company's generating station at Petersburg considered three alternatives for replacing two 15-year-old steel sheet-piling walls that had failed because of corrosion and impacts from mobile coal-handling equipment. The alternatives were precast prestressed concrete, structural steel, and cast-in-place concrete. The Precast Concrete Institution (PCI) (1985) described the project.

A primary criterion in the selection of a replacement method was the length of time the coal stockout boom would be out of service. The maximum time limit set by the company was 12 days. Precasting was selected because it required the stockout boom to be out of use for only 10 days; in addition, the precast concrete would not be susceptible to coal leachates as was the steel, and the smooth face of the panels would facilitate compaction of the coal, thus reducing the number of voids, which are sources of spontaneous combustion.

Figure 205 is a diagram of the coal storage area. The retaining wall (A) adjacent to the coal stockout boom and the one (B) adjacent to the coal reclaim tunnel were replaced with precast concrete panels. The panels and columns were cast at a casting yard about 50 miles from Petersburg and

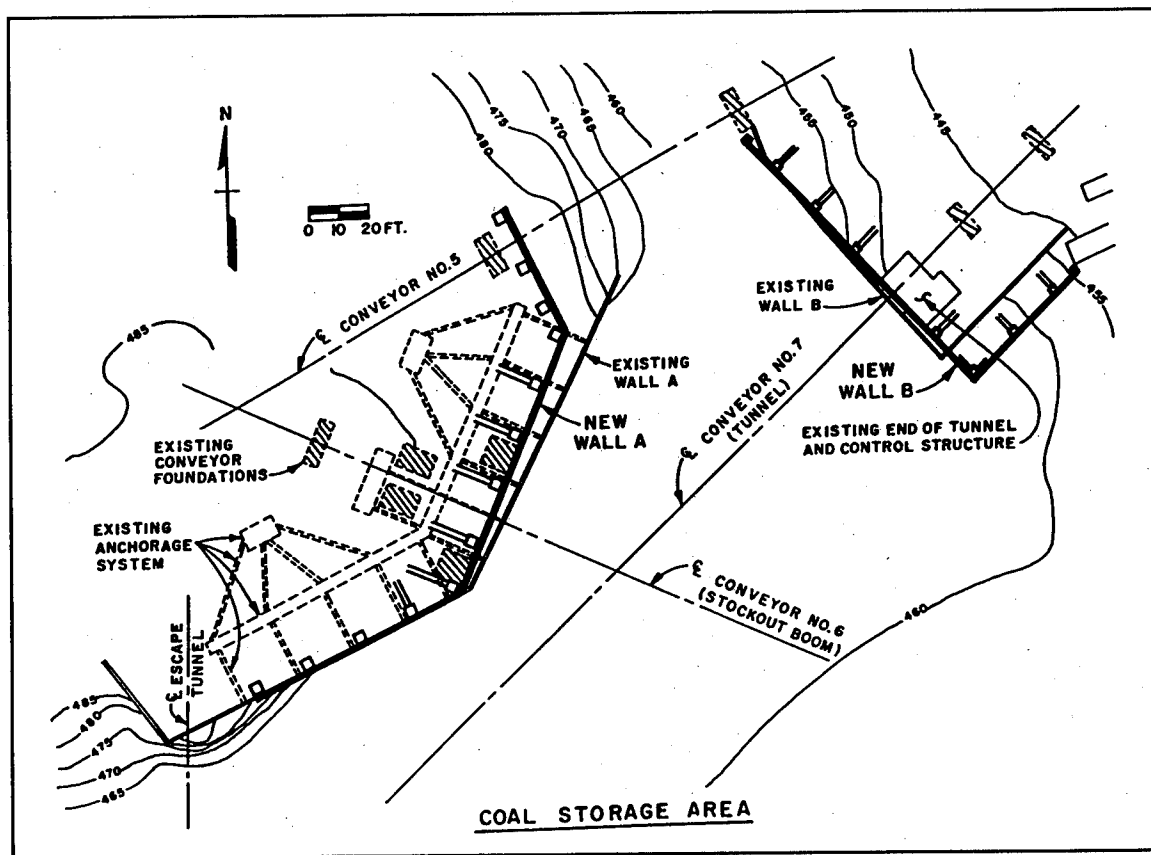

Figure 205. Diagram of Indiana Power & Light coal storage area (from PCI 1985)

shipped as needed. Specifications for the precast concrete called for a compressive strength of 5,000 to 6,000 psi at 28 days. The minimum strength required at the time of prestressing was 4,000 psi. A 1/2-in. low-relaxation strand with a yield strength of 270,000 psi was used for prestressing.

The first phase of construction was the setting of the precast columns. Wall A required 13 columns; Wall B, 9. Holes for the columns were drilled through medium to stiff clay and 5 ft into weathered rock. As each column was set, cast-in-place concrete (with a minimum 28-day compressive strength of 3,500 psi) was placed around the bottom 4 ft of the column. The horizontal struts for Wall A were cast in place and attached to an existing concrete wall, and the precast rakers were installed.

The next step was to install the panels (Figure 206). The earth-side of Wall A was covered with a preformed rigid membrane so subsurface water would drain from the retaining wall. The bottom 20 ft of the panels for Wall A received horizontal pressure from both earth and coal (Figure 206). Because of the dual pressure, this section was attached to the columns with 1-in.-diam coil bolts. The bolts were countersunk into the panels and then covered with epoxy grout for corrosion protection. Steel clip angles were used to attach the 20-ft section above ground as this portion of the wall was designed for coal loading only. Clip angles were used to attach all of the

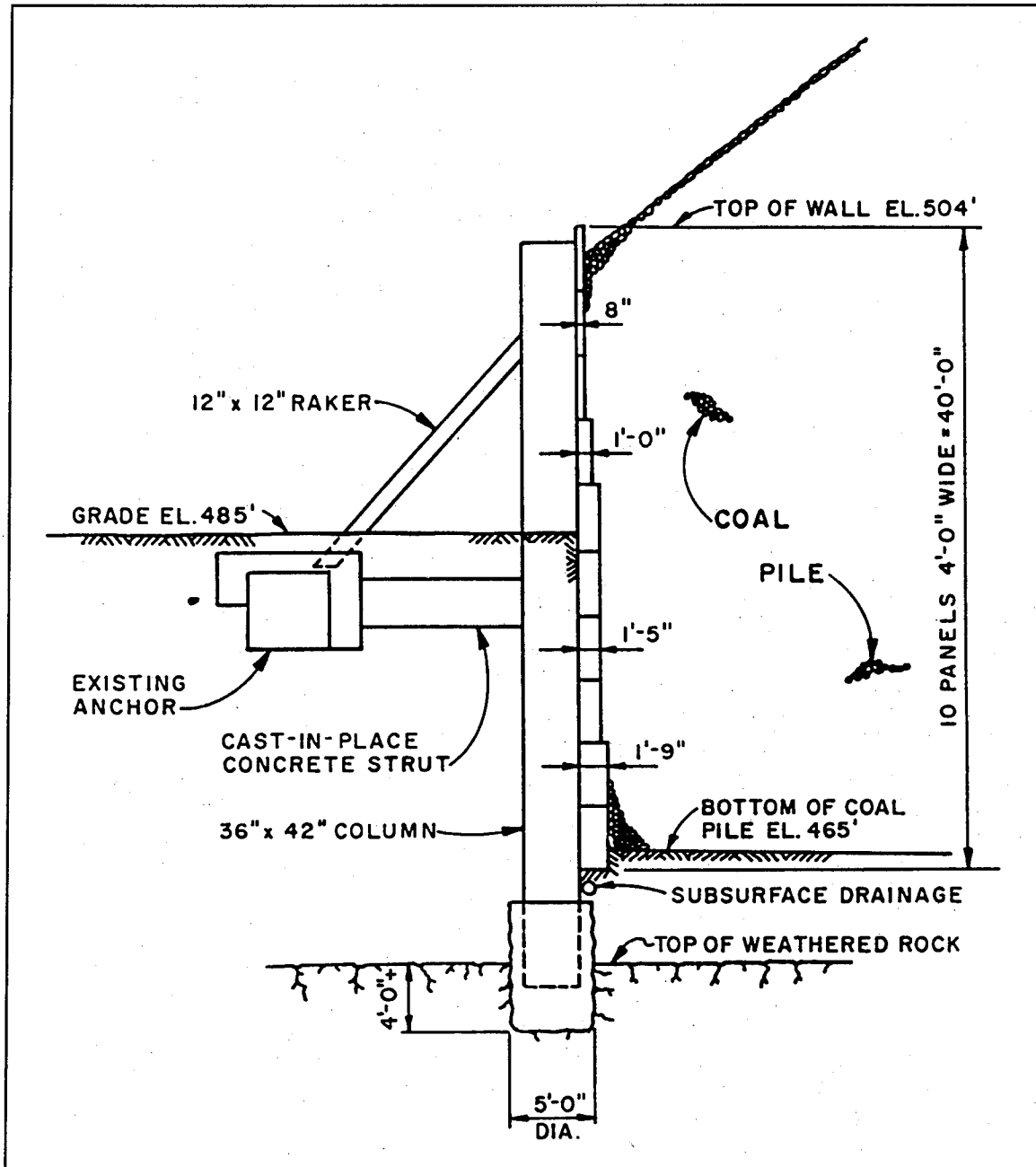

Figure 206. Typical precast panel section for Wall A at Indiana Power & Light coal storage facility (from PCI 1985)

panels for Wall B as loading was experienced in only one direction (Figure 207).

Retaining Wall A is 40 ft tall with a total surface area of 6,057 sq ft. The prestressed, precast panels for this wall vary in thickness from 8 to 21 in. and in length from 9 ft 4 in. to 37 ft 6 in. Wall B is 16 ft tall with a total surface area of 2,351 sq ft. Panels for this section are from 8 to 17 in. thick and

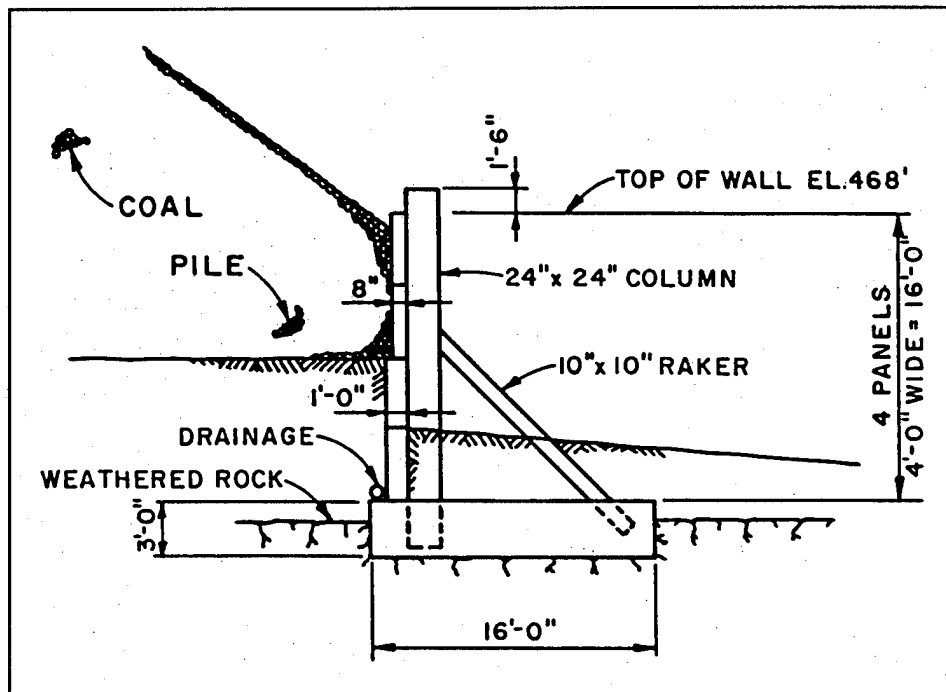

Figure 207. Typical precast panel section for Wall B at Indiana Power & Light coal storage facility (from PCI 1985)

from 12 ft 2 in. to 38 ft long. The heaviest column used is 46 ft 6 in. long and weighs 66,000 lb; the largest panel is 38 ft long and 21 in. thick.

The total cost of the project was \$690,000. Cost for the precast, prestressed concrete was approximately \$250,000. The project was completed within 4 months, between August and November 1984.

Massachusetts Shopping Mall

A Massachusetts general contractor building a three-level, enclosed shopping mall scheduled to open in the fall of 1989 contracted out the construction of 664 lin ft of retaining wall at the mall site. The contractor for the retaining wall used a patented system developed in Europe by Randall (1989) described the project.

The retaining wall consists of three parts: a plain concrete foundation block and a base slab, which are cast-in-place, and precast panels. The concrete for the foundation block is nonreinforced. The width and thickness of the block are dependent upon the height of the wall. Braces, which are cast integrally with the panel, support panels up to 16 ft high (Figure 208). Panels up to 43 ft are supported additionally by a precast concrete strut hinged to the brace at midheight. The hinge is formed with a large pin threaded through overlapping loops. Expansive grout is used to provide corrosion protection for the hinge.

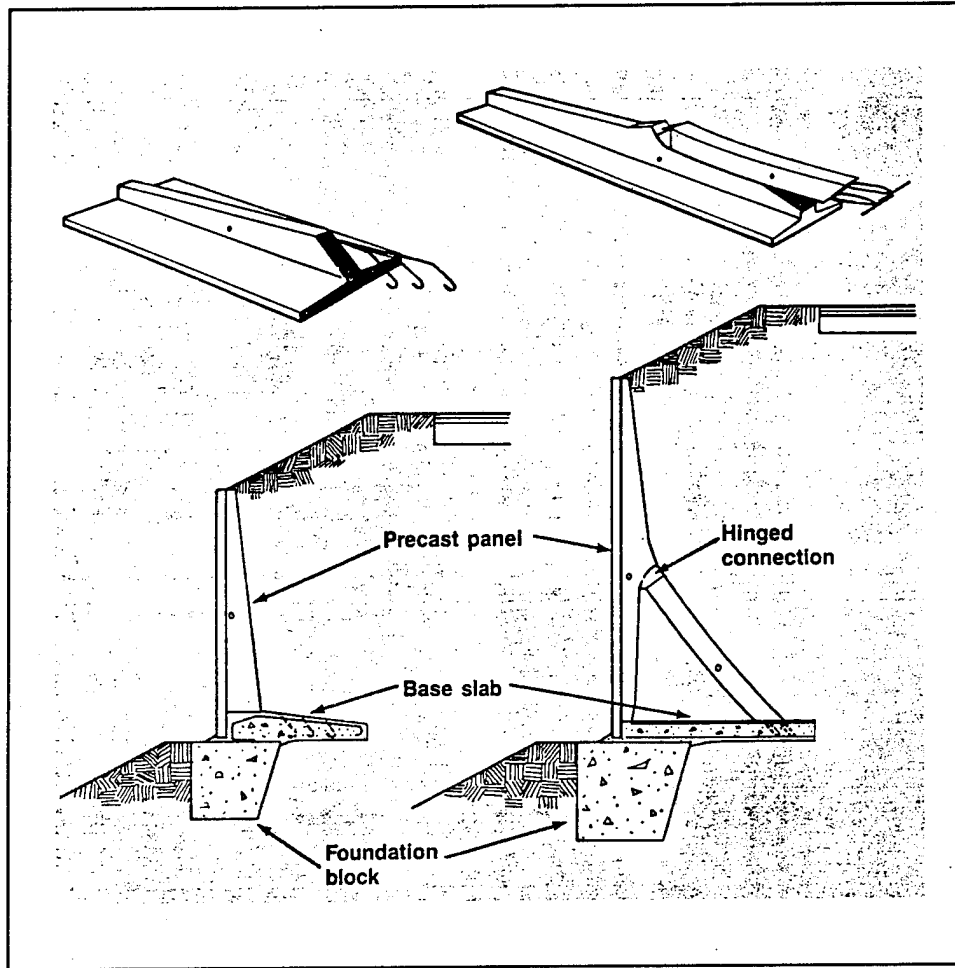

Figure 208. Design for retaining-wall system used for shopping mall in Massachusetts; this wall supports panels to 16 ft high (from Randall 1989)

Reinforcing bars that protrude from the base of the counterfort are used as reinforcing for the base slab. The base slab rests partly on the foundation block and partly on the soil behind the block. Adjacent panels are joined with compression seals which stop 6 in. from the bottom of the wall, creating weep holes. A 2-ft layer of backfill gravel on the back of the wall provides drainage for the weep holes.

Two retaining walls were built at the shopping mall, one a 300-ft-long section and the other 295 ft long. The foundation blocks were cast in mid-November. The 166 4-ft-wide panels used for the project were erected between December 12 and January 6; at times the temperature was zero degrees. The base slabs were protected during curing with polyethylene sheeting and unbroken bales of hay. When the concrete in the base slabs reached 3,000 psi, the walls were backfilled.

The precast retaining-wall system offers several advantages: it saves time--a cast-in-place cantilever retaining wall requires about 4 additional months to

construct; it is easy to dismantle and move--a section of one of the walls was removed for a later phase of construction; it saves money--because it is less massive than conventional retaining walls and having the wall removed and relocated is less costly.

Pen-y-Clip Retaining Wall

The Pen-y-Clip Tunnel is part of the A55 North Wales Coast Road project. It connects North Wales to the national motorway system of the United Kingdom, and the road forms part of Euroroute No. 22, which runs from Dublin to the Baltic. The tunnel goes through the rock headland known as Pen-y-Clip. At the tunnel exit at the foot of the mountain, the ground slopes between 30 and 40 deg and is composed mainly of scree and quarry debris. A decision was made to build a wall to retain the exit cutting. In addition to its practical function, the retaining wall had to be approved by the Royal Fine Arts Commission because it would be located on the northern edge of the Snowdonia National Park, a particularly environmentally sensitive area (*Concrete* 1993).

Alternatives considered for the retaining wall included an anchored diaphragm, anchored bored pile, a conventional gravity retaining wall, and a precast concrete panel wall. The option selected was a precast concrete panel wall fixed to the mountainside with stressed ground anchors (Figure 209). The anchors would stabilize the slope, and the precast concrete panels would distribute local anchorage forces, provide weather protection to the excavated slope, and present a high-quality finished appearance. This option met the structural, logistical, and aesthetic aspects of the project.

Unusual features of the wall, which is 715 ft long and up to 98 ft high, are that it was constructed from the top downwards and it has no conventional foundations as it was designed to be integral with the retained soil.

Seven hundred fifty-eight ground anchors, up to 98 ft long, with working loads of up to 600 kN were installed through preformed holes in the reinforced concrete panels and anchored in the mudstone or microdiorite behind. The individually anchored precast panels permit movement at each panel boundary so there was no need for movement joints. Facing panels are backed by a drainage layer of no-fines concrete to prevent a buildup of water pressure behind the units.

At the top of the anchored sections, a precast concrete parapet was constructed along the maintenance track to provide safety during maintenance operations, and a cast-in-place wall serves as a rock trap.

The precast panels and the cast-in-place concrete rock trap wall have a hammered rib finish. Formed ribs were allowed to gain sufficient strength so the specified dark grey coarse aggregate would split and shatter when systematically struck with a hammer, producing a rugged finish to complement the exposed scree slopes and rock faces on the mountainside and to contrast

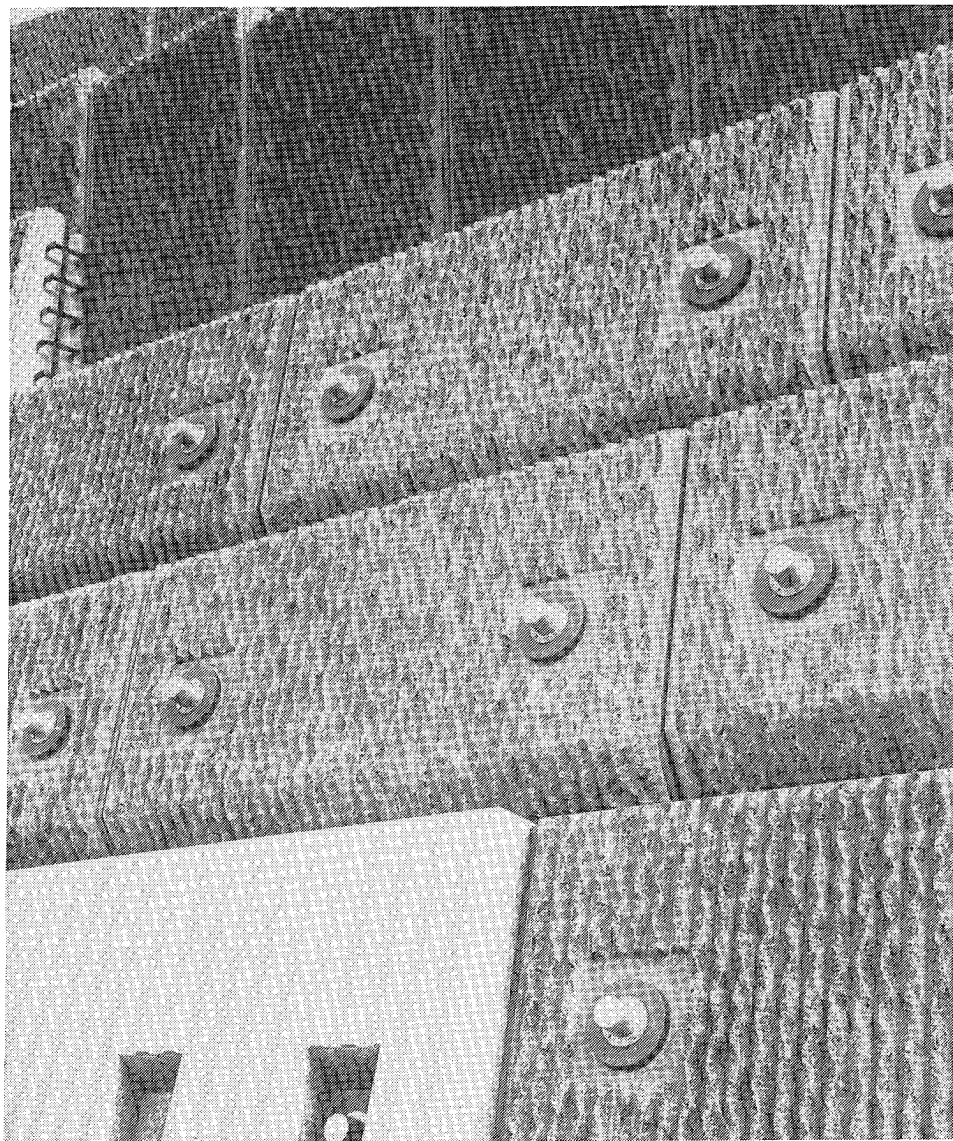

Figure 209. Close-up of the precast concrete panel wall at Pen-y-Clip Tunnel (from *Concrete* 1993)

with the architectural finish of the reinforced concrete tunnel canopy (Figure 210).

To fill the area between the eastern end of the retaining wall and the tunnel's West Portal, the contractor used cast-in-place concrete sections designed to blend with the exposed rockhead. At the western end of the wall, he constructed a conventional gravity wall to provide a transition to existing ground levels.

This project received the premier award in the Civil Engineering Category because of its high-quality appearance, skillful attention to detail, and its cost-effective solution to this most difficult civil engineering problem.

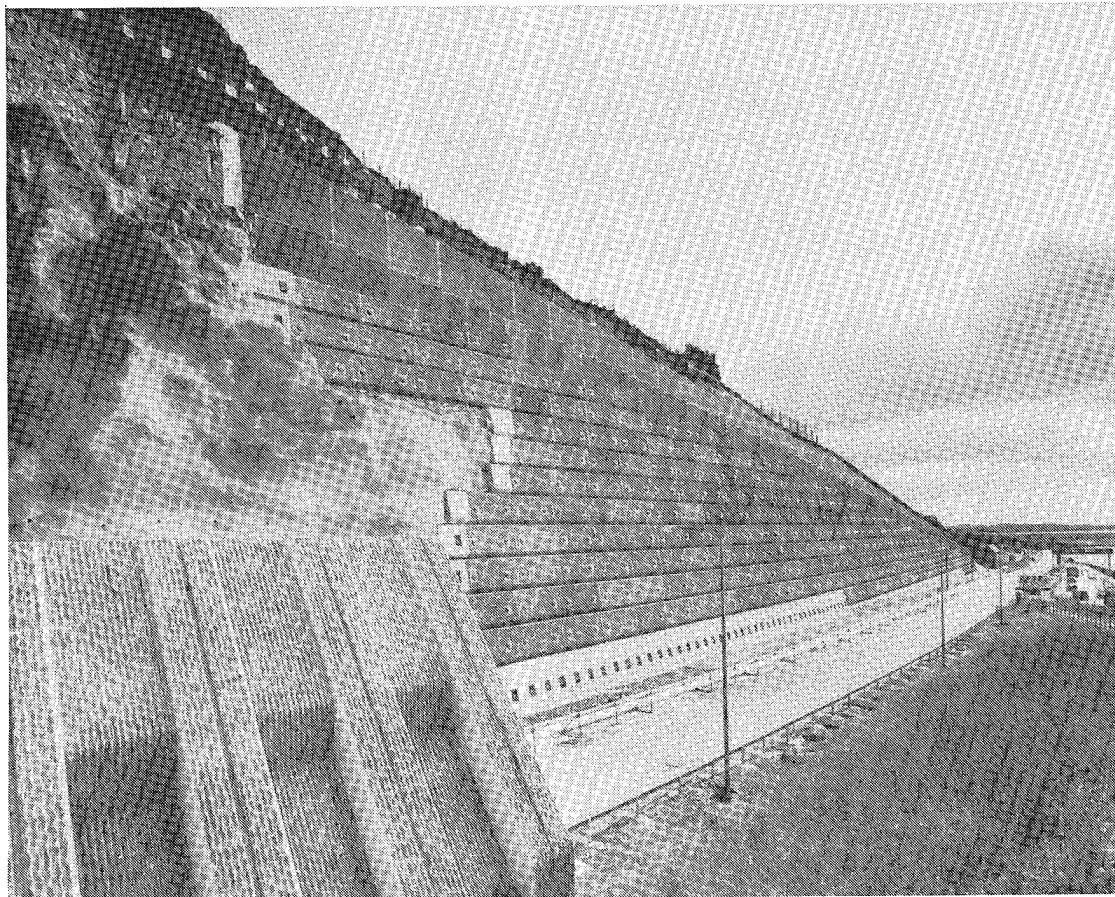

Figure 210. Precast concrete panel retaining wall at Pen-y-Clip Tunnel (from *Concrete* 1993)

Interstate Route 80, New Jersey

In 1987, the New Jersey Department of Transportation (NJDOT) installed 17,000 lin ft of precast concrete panels along Interstate Route 80, Section 8M, Morris County, to serve as a noise barrier (Figure 211). The concrete wall also extended along existing bridges that crossed local roads. Guzaltan (1992) described the project.

Two designs for the wall were presented to Morris County residents at a public meeting in December 1987. One design used wood; the other, concrete. Concrete was the preferred option; the reasons cited for the choice were that concrete is more durable and more aesthetically pleasing than wood.

Two problems occurred during design. The first was the lack of any established design criteria for noise barriers. The contractor overcame this problem by using ASCE Paper No. 3269.

The second problem involved construction of the noise barrier wall along bridges. After an analysis of bridge structure, the contractor concluded that one or two of the existing beams on a bridge would have to be replaced if the



Figure 211. Section of precast concrete post and panel noise barrier wall installed along Interstate Route 80, New Jersey (from Guzaltan 1992)

bridge was to carry the precast concrete panels that formed the wall. Beam replacement cost, traffic interruptions, and construction time ruled out the beam-replacement option.

The most practical and cost-effective solution to the second problem was the construction of a steel and concrete support system. The system consists of reinforced-concrete pedestals, steel support towers, and a Vierendeel double-truss. The reinforced-concrete pedestals, which reach to the top level of the bridge substructure, were designed to blend with the bridge piers, abutments, and wing walls. The steel towers are mounted on the pedestals; they support the Vierendeel double-truss, which holds the precast concrete panels (Figure 212).

Concrete with a compressive strength of 5,000 psi was used in casting the posts and panels. Grade 60 steel bars were used as reinforcing. In addition to the steel bars, the 5-in.-thick panels were also reinforced with wire mesh. Lifting inserts were cast in all units to minimize damage during installation. To improve the appearance of the walls and make them fit into the surroundings, the finish on the residential side was textured and on the traffic side smooth. All precast units were stained the color of adobe.

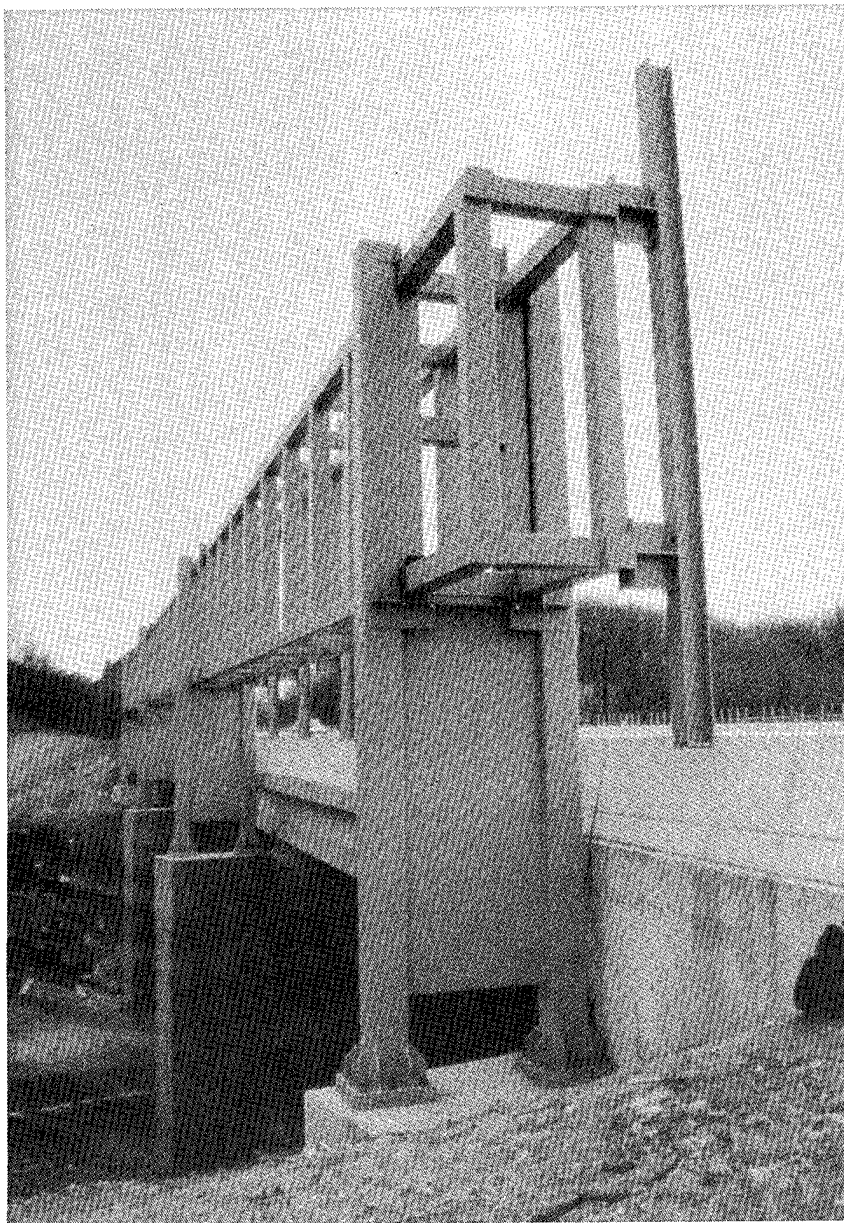

Figure 212. Concrete and steel structure used to support precast concrete panels along bridges on New Jersey Interstate Route 80 (from Guzaltan 1992)

The noise barrier wall installed on the ground consists of I-shaped, precast reinforced concrete posts and panels. The posts are installed on 15-ft centers. The precast panels are 14 ft 2 in. long and either 2 or 4 ft high to accommodate the variances in ground elevation. The panels were lowered into position between the posts (Figure 213).

Total cost for the project, which was completed in October 1991, was \$5 million. The ground-mounted barrier walls, including panels, posts, and foundations, were \$18 per sq ft. The independent noise barrier structures

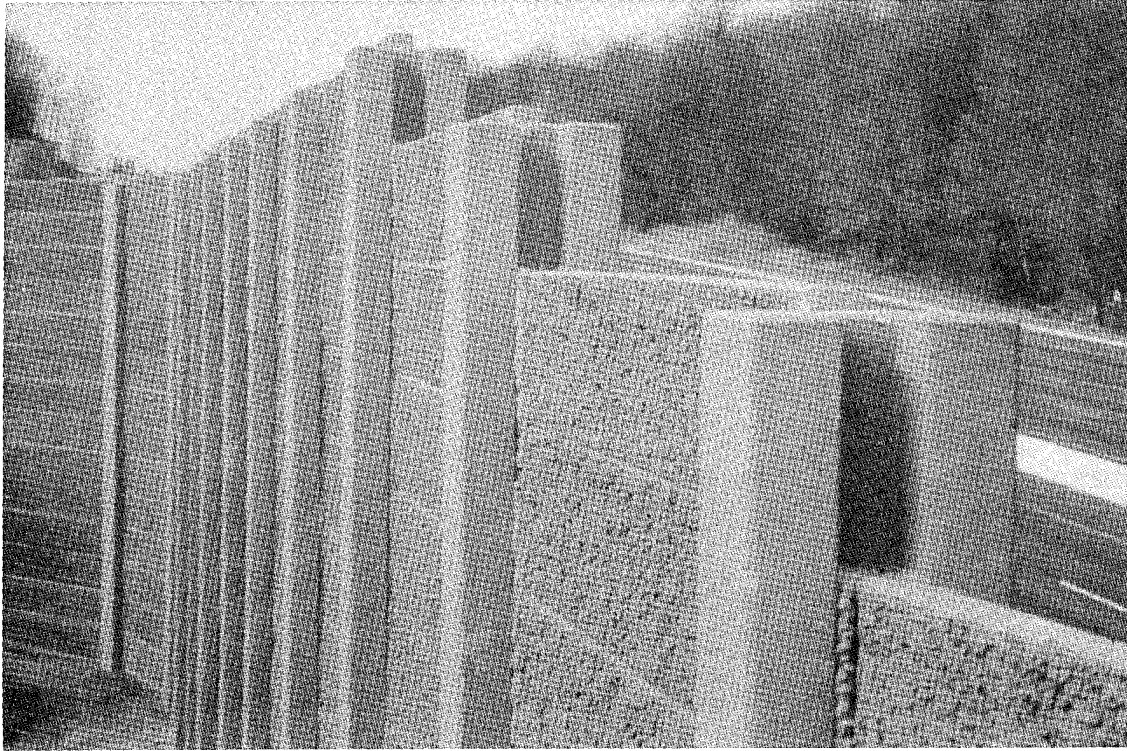

Figure 213. Precast I-shaped posts and panels used to form noise barrier wall along New Jersey Interstate Route 80 (from Guzaltan 1992)

were \$88 per sq ft. The concrete substructures and the steel superstructures increased the cost for these units.

Because of the success of this project, the NJDOT elected to use the same method on another section of Interstate Route 80. The six independent noise barrier walls in the new section will total 35,000 lin ft and 752,000 sq ft in surface area.

Kildonan Corridor Noise Attenuation Barrier

The Kildonan Corridor Noise Attenuation Barrier is a half-mile-long structure along the Chief Peguis Trail in Winnipeg, Canada. The wall, which was constructed to block traffic noise from the surrounding neighborhood, consists of precast concrete columns and wall panels. Unusual features of the wall are that no hardware was used in its installation and a number of panels were cast with murals depicting the historic York boats, which the early Scottish and Irish settlers sailed on the Red River (Figure 214).

Ulyatt and Winch (1992) described the noise barrier wall and its construction. The City of Winnipeg elected to use precast concrete for the noise barrier over other alternatives for the following reasons:

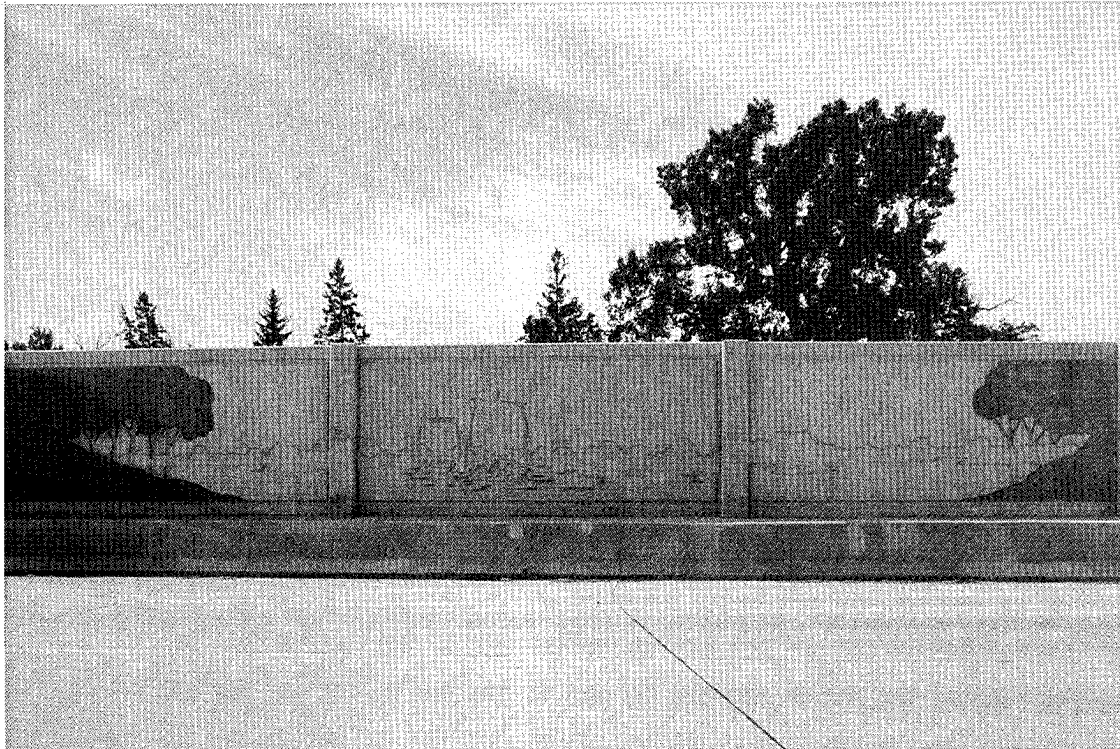

Figure 214. Precast concrete noise barrier with murals, Winnipeg, Canada (from Ulyatt and Winch 1992)

- a. Controlled factory conditions would produce a high quality of concrete.
- b. The use of precast concrete components made it possible to complete the entire project within 3 months.
- c. Congestion caused by other contractors working in the same area would have made casting onsite very difficult, if not impossible.
- d. Precasting the panels with art work was easier than site casting them would have been.
- e. An aesthetic surface was easier to achieve with precasting.
- f. Precasting was more cost-effective than site casting would have been.

The contract was awarded 3 July 1990. During the next 4 weeks, the drawings for the murals were completed and approved, the materials were acquired, and the forms constructed. The artist and the precaster worked together on a 4- by 4-ft test model of the panels before the actual panels were cast. Precasting began 3 August 1990. The panels were cast in wooden forms with a 1-in.-thick liner. Panels were moist cured in the forms until they reached a strength of 2,900 psi. After removal, they were set in frames

and moist cured for another 24 hr. The side of the panel that would face the residential area was sandblasted to expose the aggregate.

The precast concrete panels are supported by precast concrete columns erected on cast-in-place pile caps (Figure 215). The pile caps were cast with corrugated holes in the center. The columns were cast with dowels projecting from the bottom. The holes in the pile caps were filled with nonshrink grout. When the columns were raised into position, the dowels were inserted into the grouted holes in the pile caps. A grout pad was used to make final adjustment in column elevation.

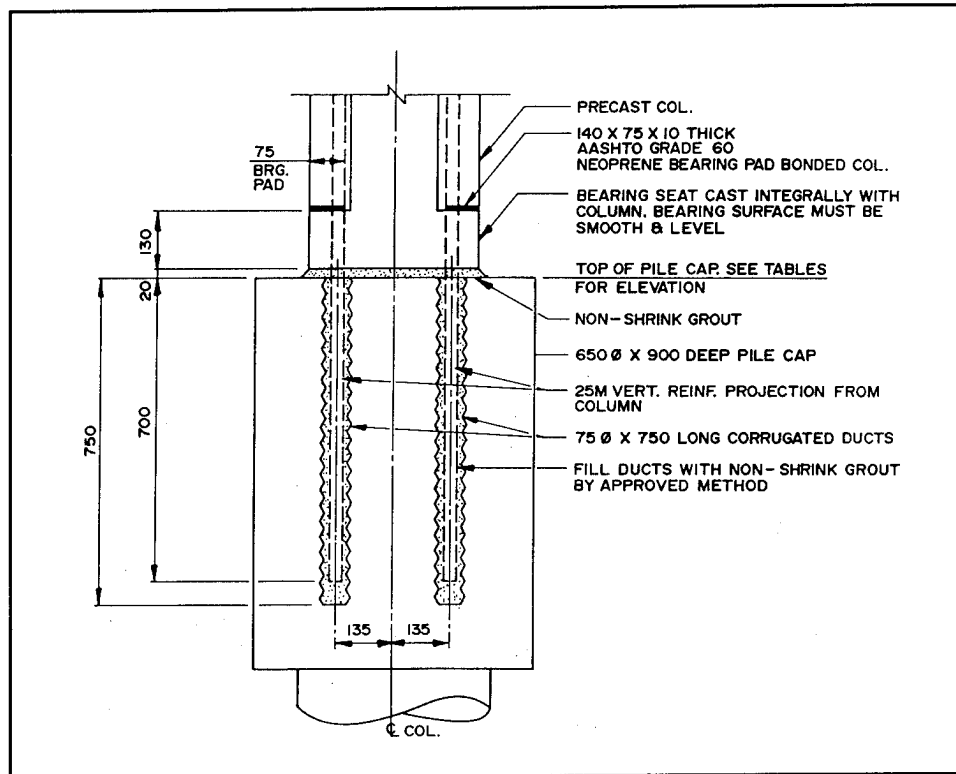

Figure 215. Drawing that shows how columns were anchored to pile caps, Winnipeg (from Ulyatt and Winch 1992)

A structural steel angle was cast into the corners of each wall panel to serve as a bearing seat when the panels were installed. The panels fit into slots in the columns; plastic shims were fitted into the space between panels and columns to provide stability (Figure 216).

A traffic safety barrier was built immediately next to the roadway with the noise barrier approximately 8 ft behind it. The area between the two was landscaped with shrubs to soften the long line of concrete, thus making the barrier more aesthetically pleasing (Figure 217).

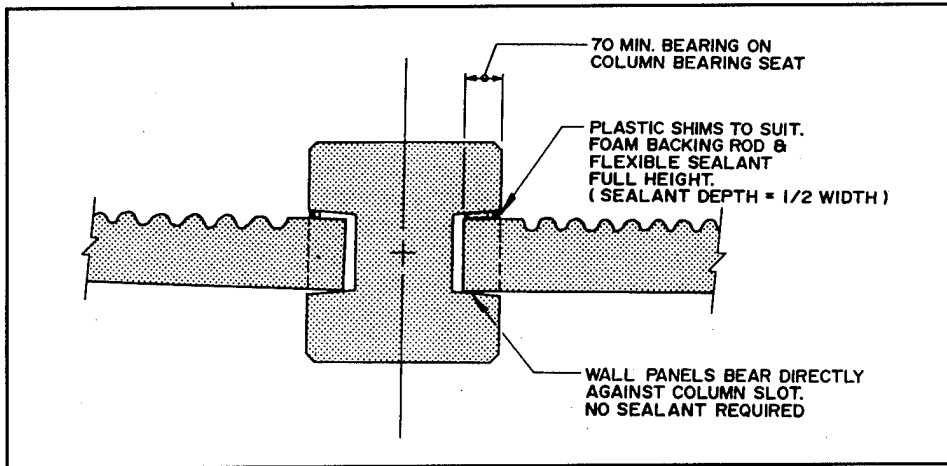

Figure 216. Top view of panel-to-column installation of noise barrier, Winnipeg (from Ulyatt and Winch 1992)

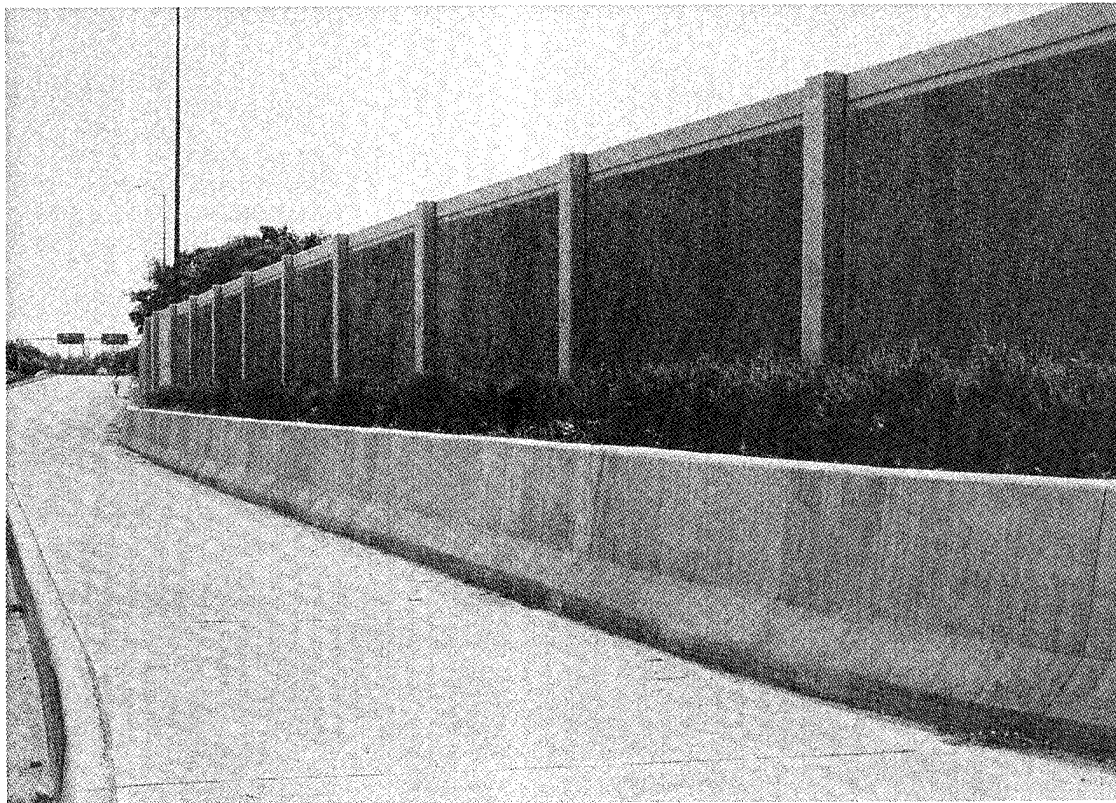

Figure 217. Completed precast concrete noise barrier with safety barrier and landscaping at Winnipeg, Canada (from Ulyatt and Winch 1992)

Precast Concrete Paving Blocks

Precast concrete paving blocks are being used to construct a type of flexible pavement that can withstand heavy, concentrated, or abrasive loads and

chemical spills and that requires very little maintenance. The paving blocks, typically cast from a mixture of well-graded aggregates and hydrated portland cement, are placed on a base consisting of approximately 30 in. of restructured soil, stone, and sand (Figure 218). Generally, the blocks are about the size of a common brick. They are 2-3/8 to 4 in. thick and weigh from 9 to 12 lb. Though they are manufactured in a variety of shapes, the rectangular shape is the most common (Figure 219). The blocks are placed by hand or with mechanical laying equipment on a 1- to 1-1/2-in. layer of leveling sand. They are then compacted so they will be seated in the sand layer, and some of the sand will be pushed into the joints. Additional sand is used to fill the joints between the blocks, and then the area is recompact. If heavy-load traffic will use the area, a steel-wheel or pneumatic roller is used for the final compaction (Anderton 1991a).

Paving blocks are mass produced. The concrete mixture is injected into molds and then consolidated by intense pressure and vibration. After being removed from the molds, the blocks are carried to a curing area by a conveyor belt system. A typical mixture of the stiff, zero slump concrete used for casting the blocks contains 14-percent Type I cement, a water-cement ratio of 0.4, and an aggregate ratio of 70-percent sand to 30 percent gravel with a maximum size of about 1/4 in. An average compressive strength of 8,000 psi at 28 days (with no samples measuring less than 7,200 psi) is required. To protect against cycles of freezing and thawing, the entrained air content of the fresh concrete should be 6 percent, \pm 1-1/2 percent (Anderton 1991a). Synthetic or natural iron oxide pigments may be added to obtain a desired color.

Until recently, contractors in the United States have reserved the use of precast concrete paving blocks for sidewalks, courtyards, driveways, and parking areas. In these applications, the appearance of the paving blocks was as important as their usefulness. However, interest in the potential of precast concrete blocks as paving material for airfields has increased as a result of two civilian applications. The concrete block pavers used to resurface the runway ends at Luton Airport (north of London, United Kingdom) have performed successfully for approximately 7 years. In 1990, paving blocks were used in construction of three cross taxiways at the Dallas Fort Worth International Airport (Anderton 1991b).

Dallas-Fort Worth International Airport

In 1990, Dallas Fort Worth International Airport (DFW) began a \$3.5-billion capital improvements program that would allow air operations and passenger traffic to double by the year 2010. The first project in the program was to build taxiways for the "West Side Development Plan." A prime consideration in the selection of a construction method was the amount of time needed for construction. Runway closings impacted not only DFW but all airlines tied to it. The DFW Planning and Engineering Department wanted to find a method that would reduce the estimated 14-hr nighttime closings that would be required for construction of a typical rigid pavement. Among the options the Department sent to the contractor for consideration was one that

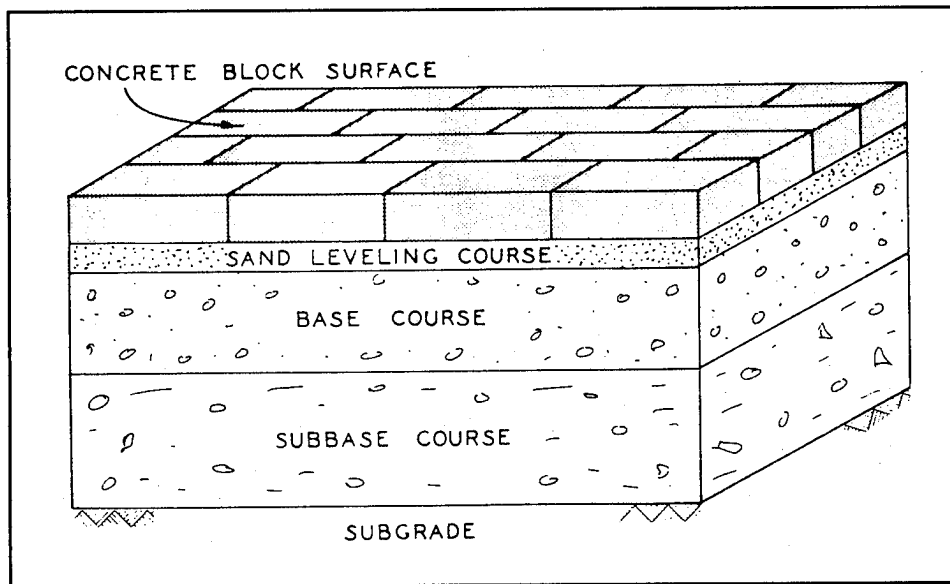

Figure 218. Cross section of typical block pavement (from Anderton 1991a)

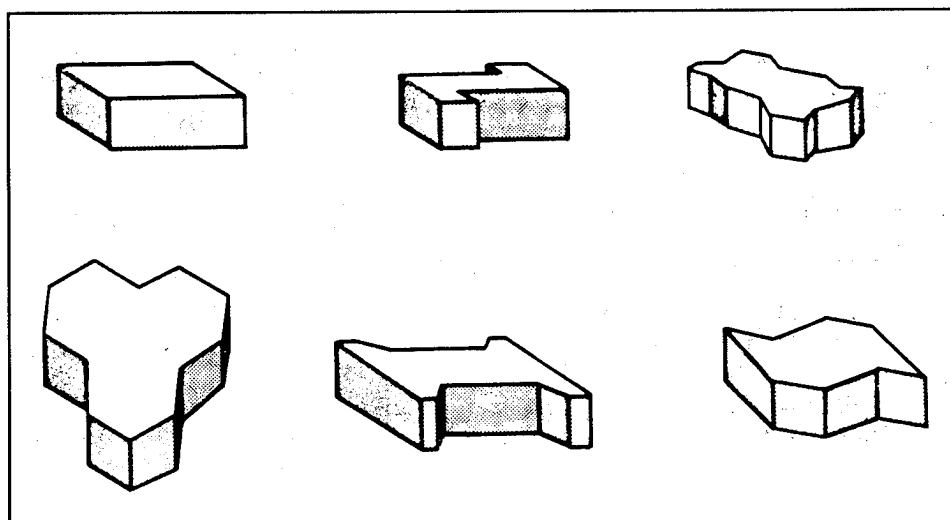

Figure 219. Examples of paving-block shapes (from Anderton 1991a)

used interlocking concrete pavers. King and Smith (1991) described the use of concrete paving blocks at DFW.

For more than 35 years, these small, precast concrete blocks have been used in Europe for streets, sidewalks, commercial and military airfields, parking areas, and in ports. Investigations revealed that the pavers could withstand heavy loads and harsh weather, that the taxiways could be constructed during 12-hr closures, and only 30 min was required to remove all workers, equipment, and material from the construction site. Another benefit was that the pavement would be ready for traffic immediately after installation as the precast pavers would be already cured.

Concrete specifications for the precast pavers for the DFW taxiways were based on ASTM C 936 (1989) with all requirements being equal to or greater than those of the ASTM standard. The requirement for compressive strength was a minimum of 7,200 psi for individual units and an average of at least 8,000 psi at 28 days; a minimum of 650 psi at 28 days was required for tensile splitting strength. Absorption requirements were 6 percent or less for individual units with a minimum average of 5 percent. Canadian Specification Association, CAN3-A231.2-M85 (1989), which exceeds the American specification, was used for freezing and thawing durability requirements.

Field and laboratory testing of the natural soil subgrade was 1.5-percent California bearing ratio (CBR). The design requirement for the subgrade was 7 percent. Pressure injection of a mixture of lime and fly ash produced a subgrade with an average CBR of 28 percent. The stabilized subgrade was covered with a 27-in.-deep cement-treated base. After the base was compacted, natural river sand was spread and screeded to a 1.5-in. depth. The paving blocks were placed on this sand (Figure 220).

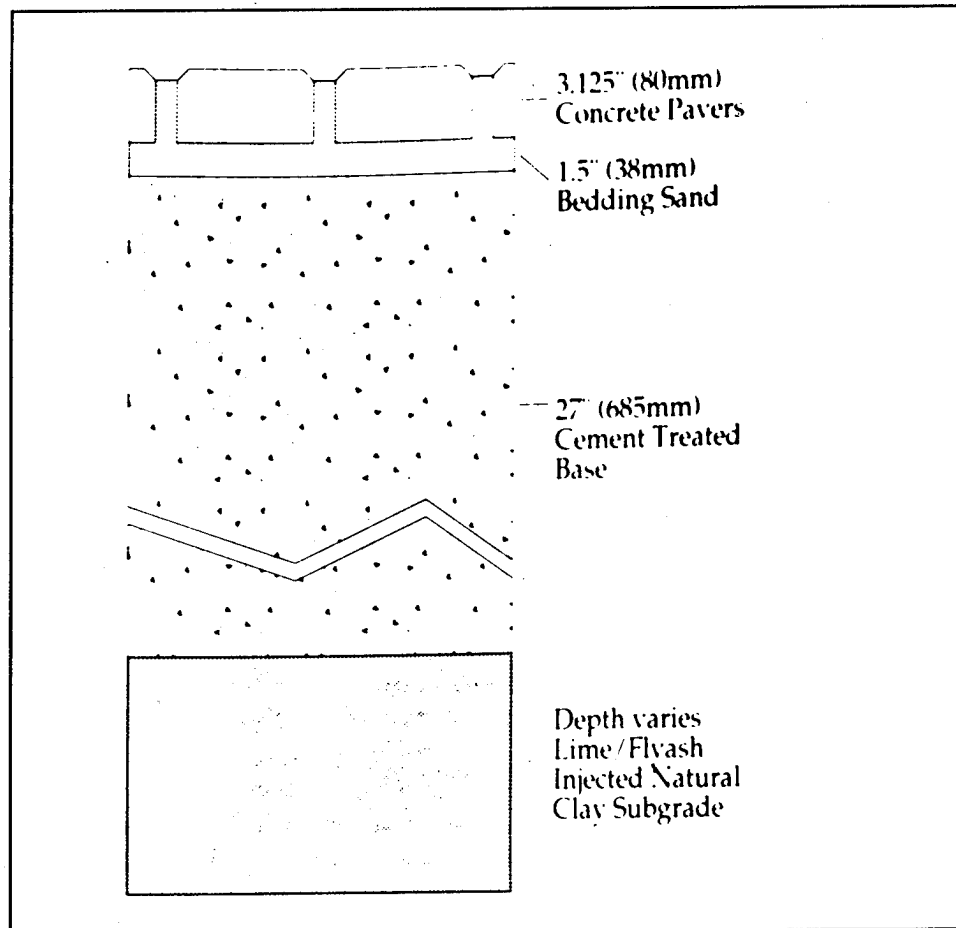

Figure 220. Cross section of base for concrete paving blocks at Dallas Fort Worth International Airport (from King and Smith 1991)

The 4- by 8- by 3-1/8-in.-thick precast pavers were placed in a 45-deg herringbone pattern (Figure 221). At the end of each night's work, a hand-operated plate compactor was used to vibrate the pavers before the joints were filled with sand so that loads placed on units could be transferred to neighboring units. An 8- to 10-ton rubber-coated vibratory drum roller was used for final compaction. The last step was to seal the pavement with a clear, flexible, polymer spray.

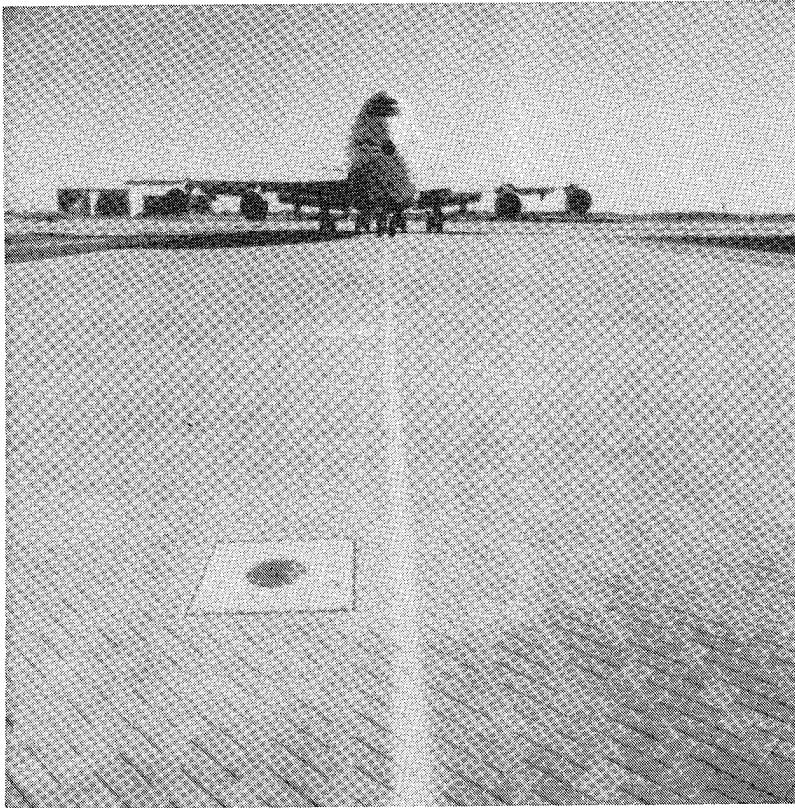

Figure 221. Concrete paving blocks placed in herringbone pattern on taxiways at Dallas Fort Worth International Airport (from King and Smith 1991)

Aberdeen Proving Ground

A demonstration of the latest concrete paving block technology was conducted at Aberdeen Proving Ground, MD, for the Directorate of Engineering and Housing community. The project was designed in 1988, constructed in 1989, and monitored in 1990 (Anderton 1991a). The project site, located on the outer rim of the Tank Retrieval Range Area, is an intersection for five range roads (Figure 222). Approximately ten 56-ton tank retrievers and ten 30-ton tracked vehicles used the unsurfaced intersection each day. The heavy traffic combined with a relatively weak subgrade at the intersection made this a good location for testing the concrete paving blocks.

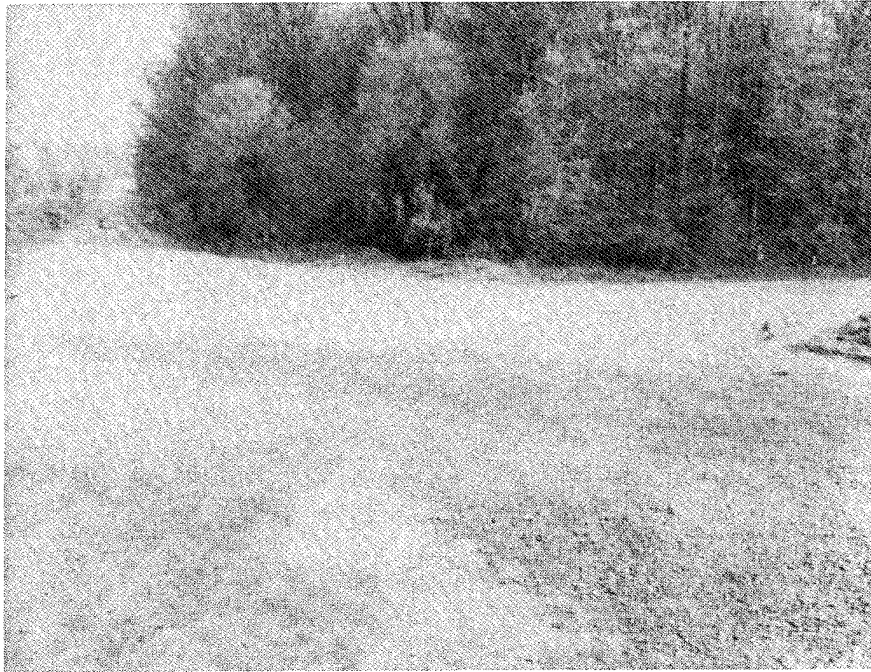

Figure 222. Intersection at Aberdeen Proving Ground before installation of concrete block pavement (from Anderton 1991a)

The U.S. Army Engineer District, Baltimore, designed the project. Personnel from WES helped with the design for the concrete block pavement. Specifications called for a total restructured depth of approximately 27 in.; this depth included the subbase fill, a crushed stone layer, a layer of sand bedding, and the rectangular paving blocks.

First, a silt barrier was placed around the intersection to prevent excessive silt loss during the earthwork stage. Then, the area was excavated and the subgrade was compacted to at least 90 percent of the CE-55 maximum density. A geotextile fabric placed on the compacted subgrade was covered with a select-fill subbase material (Figure 223). A 4-in.-deep layer of crushed stone was placed on the subbase. Both the subbase and crushed stone layers were compacted to 100 percent of the CE-55 maximum density.

When the foundation was complete, a 3-1/2-in.-high concrete curb was cast-in-place around the area. The purpose of the curb was to keep the paving blocks from moving out of line under the pressure of traffic. Once the curb had cured, bedding sand was dumped on the area and spread with screeding pipes to form a 1-in.-deep layer. Paving blocks were laid by hand in a herringbone pattern. A stringline was used to keep the blocks aligned (Figure 224).

At the end of each day, the newly laid area was compacted with a manual vibratory plate compactor to within 5 ft of the edge. Then the jointing sand was spread, broomed into the joints, and compacted with the plate compactor

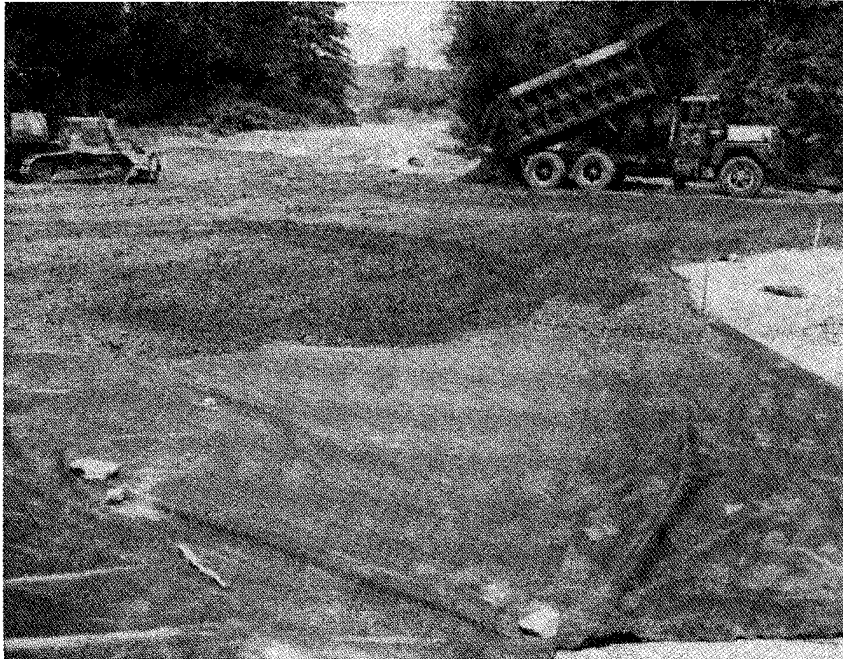

Figure 223. Fill being placed over geotextile fabric at Aberdeen Proving Ground (from Anderton 1991a)

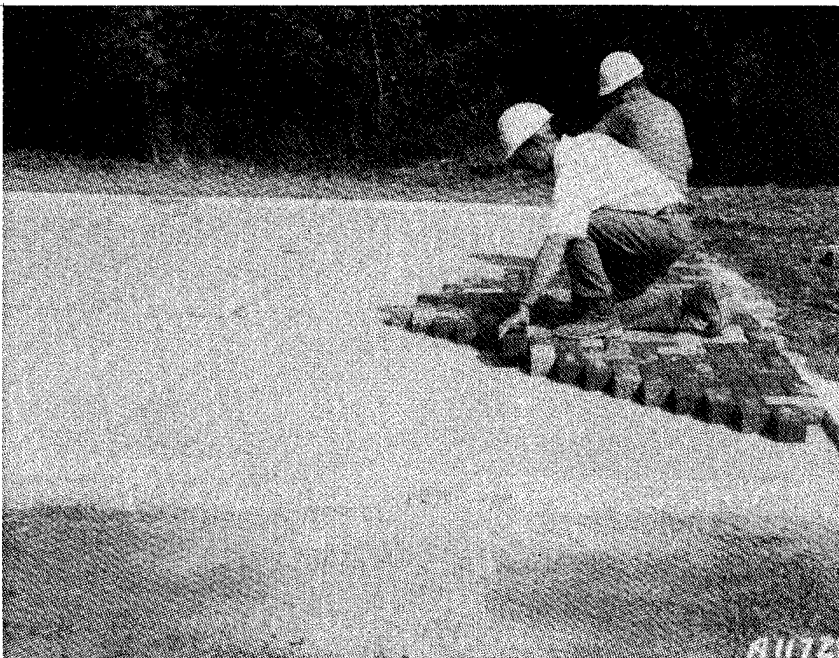

Figure 224. Concrete paving blocks being placed by hand at Aberdeen Proving Ground (from Anderton 1991a)

until all joints were filled (Figure 225). Paving blocks to be placed next to the concrete curb were split with a hand-operated device. Precast concrete block pavement was installed on the entire 12,000-sq ft intersection in approximately 16 working days.

The same day the pavement was completed, it was tested with a 56-ton M-88 tank retriever (Figure 226). Tests included low-speed straight passes, high-speed breaking and acceleration, 90-deg pivot steer turns, and finally 60-deg pivot steer turns at high speed. The blocks were undamaged; the only sign of traffic was scuff marks left on the pavement by the rubber pads on the tracks.

During the first few months of use, mud, which the tracked vehicles had carried onto the pavement, had to be scraped off; no other maintenance was required. After 8 months of service, WES personnel inspected the site. No visual damage was noted. Straight-edge measurements taken through the intersection revealed three areas of wheel rutting near the entrance areas where traffic was most channelized but no loss of structural integrity of the pavement blocks. A final inspection was made after approximately 1 year of service. Because of heavy rainfall before this visit, the heavily trafficked areas were covered with 6 to 8 in. of mud; the other areas, about 1/2 to 1 in. of mud. Visible paving blocks seemed to be in good condition (Figure 227). Personnel at the Aberdeen Proving Ground reported no requests for major maintenance for the pavement during the first year of service.

The total cost of the project, including all subbase and base work and the geotextile fabric, was \$126,743 (1989 dollars). The cost of the materials, labor, and equipment for the paving blocks was \$51,431, or approximately \$4.30 per sq ft. The design life for the concrete block pavement is 20 years; it is anticipated that very little maintenance will be required during this time.

Ontario and North Carolina Study

A recent study examined the structure, performance, and durability of interlocking concrete pavements used for urban streets in North America. The study, conducted by PCS/Law Engineering of Beltsville, MD, studied the use of concrete pavers in North Bay, Ontario; Timmins, Ontario; and Fayetteville, NC (Smith 1993).

North Bay has approximately 150,000 sq ft of concrete pavers covering roads and sidewalks (Figure 228). The base for the pavers consists of crushed aggregate topped with bedding sand. A herringbone pattern was used in the streets, where two-way traffic amounts to about 8,000 vpd, with about 13,000 vehicles passing through a major intersection. Temperatures in North Bay range from -40 °F to 96 °F; rain and snow amounts average around 40 in. per year. Approximately 300 tons of salt and sand are used on the street each winter. About 5 percent of the traffic is bus and truck; the rest, automobiles.



Figure 225. Plate compactor being used to vibrate jointing sand into paving block joints at Aberdeen Proving Ground (from Anderton 1991a)



Figure 226. An M-88 Tank Retriever tests the newly installed concrete block pavement at Aberdeen Proving Ground (from Anderton 1991a)

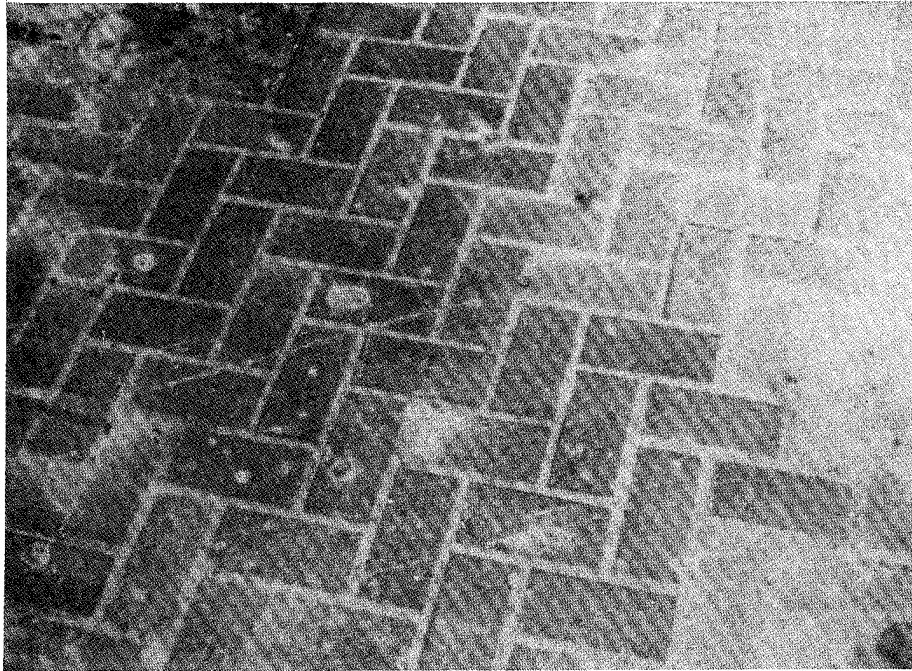

Figure 227. Close-up of concrete block pavement at Aberdeen Proving Ground after 1 year of service (from Anderton 1991a)



Figure 228. Precast concrete paving blocks on streets and sidewalks in North Bay, Ontario (from Smith 1993)

Timmins is located on northern Ontario. It has approximately 120,000 sq ft of pavers on 10 streets. Like North Bay, Timmins used the herringbone pattern and a base of crushed aggregate and bedding sand. At the test sight, two-way traffic averages about 6,000 vpd with about 5-percent trucks and buses. The climate of Timmins is similar to that of North Bay, and about the same amount of salt and sand are used on the streets each winter.

In North Carolina, the concrete pavers have been placed at Transit Mall on Hay Street in the center of Fayette. The pavers were placed on a base consisting of 8 in. of aggregate covered by 2 in. of asphalt topped by bedding sand. Temperatures in Fayetteville range from -29 °F to 110 °F; precipitation averages 19 in. per year, with very little snow. Buses make approximately 350 passes daily during the weekdays, fewer on weekends. An average bus weighs about 25,000 lb.

PCS/Law's field investigations included (a) nondestructive deflection testing to evaluate individual pavers as well as the pavement as a whole, (b) visual examination to determine types and severity of distress, and (c) actual measurement of permanent ruts.

The PCS/Law study found that the modulus of elasticity of the pavers and bedding sand increased as the traffic load increased. The highest modulus, 560 ksi, was found at intersections; the lowest, 118 ksi, in low traffic areas. The conclusion is that under heavy loads, the paving blocks lock together and share the load. The modulus of the pavers, once they have interlocked, is higher than that of hot-mix asphalt, typically 400 to 450 ksi. In addition to this strengthening with use, precast concrete block pavers have other advantages over asphalt pavements: (a) they are not affected by heat and excess loads, (b) they are not subject to cracking from loads and weather, and (c) replacing a paving block has no effect on the rest of the pavement surface because the blocks are not continuous as are conventional pavements.

After the pavers had been in use for about 6 to 8 years, PCS/Law researched maintenance records at each city, interviewed maintenance personnel, and did a visual examination of the pavers. Their findings were that no maintenance had been required except for replacement of pavers that were cut by utility companies. Only minor amounts of surface distress were observed; the cause of this distress was attributed to poor compaction of the soil where pavers had been replaced. Minor rutting was observed in all three areas, but it was the same as or less than that found in asphalt pavements with similar traffic loads. No ruts were greater than 0.75 in. No structural damage as a result of snow plowing was found in the Canadian sites.

The PCS/Law Engineering study concluded that well-constructed and correctly installed precast concrete pavers have advantages over conventional pavements used in urban areas.

3 Summary

Navigation Locks

Approximately half of the navigation lock chambers owned and operated by the Corps of Engineers were built prior to 1940. Consequently, the concrete in these structures does not contain intentionally entrained air and is therefore susceptible to deterioration by freezing and thawing. Since more than three-fourths of these older structures are located in the Corps' North Central and Ohio River Divisions, areas of relatively severe climatic exposure, it is not surprising that the concrete in many of these structures exhibits significant freeze-thaw deterioration. Depending upon exposure conditions, depths of concrete deterioration can range from surface scaling to several feet. By the late 1970s, deterioration in many of these structures had progressed to the point that major rehabilitation was required.

Initially, the general approach in lock wall rehabilitation was to use materials and methods normally associated with new concrete construction: dewater the structure; remove 1 to 3 ft of deteriorated concrete from the face of the lock wall; and replace with conventional air-entrained concrete. One of the most persistent problems in lock wall repair with this approach was cracking in the replacement concrete. These cracks, which extended completely through the replacement concrete, were attributed primarily to the restraint provided through bond to the stable mass of existing concrete. As the relatively thin layer of resurfacing concrete attempted to contract as a result of shrinkage, thermal gradients, and autogenous volume changes, tensile strains developed in the replacement concrete. When these strains exceed the ultimate tensile strain capacity of the replacement concrete, cracks developed.

Stay-in-place forms

One approach to controlling cracking is to use precast concrete panels as permanent stay-in-place forms. This system, developed as part of the original REMR Research Program, offers several advantages over conventional cast-in-place concrete, including minimal cracking in the replacement concrete, a reduction in cold-weather concrete-placement costs, and a reduction in the construction period. The initial application of the precast concrete stay-in-place forming system was at Lock 22, Mississippi River, in 1989. Despite

severe winter weather conditions, the precast panels were installed in about one-half the time required for cast-in-place concrete.

Based on the experience gained at Lock 22, the design of the precast system was significantly enhanced prior to the second application at Troy Lock, Hudson River, during the winter of 1991-92. As a result of these improvements, the contractor's bid price for resurfacing the lock chamber with precast concrete was only \$33 per sq ft at Troy Lock compared to \$91 per sq ft at Lock 22. The mean bid price for precast concrete at Troy Lock was approximately \$5 per sq ft lower than the mean bid price for cast-in-place concrete during the same period. It should be noted that although the contractor at Troy was inexperienced in both lock rehabilitation and the use of precast concrete, the project progressed quite smoothly. Also, the efficiencies of using precast concrete became very obvious as the project was completed. It is anticipated that as the number of qualified precast suppliers continues to increase and as contractors become more familiar with the advantages of precast concrete, the costs of the precast concrete stay-in-place forming system will be reduced.

Prior to application of the precast concrete in the lock chamber, cast-in-place concrete was used to resurface the miter gate monoliths at Troy Lock during the winter of 1988-89. Extensive concrete cracking in these repairs was a primary consideration in the New York District's selection of precast concrete for rehabilitation of the remaining lock chamber monoliths. These applications of both cast-in-place concrete and precast concrete in the same rehabilitation provided a unique opportunity for a direct comparison of the relative merits of the two systems. Compared with cast-in-place concrete, precast concrete exhibited a number of advantages including minimal cracking, durability, rapid construction, improved impact and abrasion resistance, improved appearance, and anticipated reductions in future maintenance costs. Also, precasting minimized the impact of adverse winter weather.

As a result of the successful application of precast concrete at Troy Lock, the New York State Thruway Authority (NYSTA) used the stay-in-place forming system to rehabilitate Lock O-6, Oswego Canal, and Lock E-3, Erie Canal, during the winters of 1992-93 and 1993-94, respectively. Also, the Pittsburgh District used the stay-in-place forming system for rehabilitation of Lock 4, Allegheny River, during the fall of 1994, and the NYSTA used the system for rehabilitation of Lock C-2, Champlain Canal, during the winter of 1994-95.

Overlays

Where structural and operational constraints permit, a concrete overlay can be placed over deteriorated concrete to protect the existing concrete from further disintegration. For example, a 12-in. thick concrete overlay was placed on the backside of the river wall at Dresden Island Lock (McDonald 1987a). Although the overlay appears to be serving its intended function, the cast-in-place concrete exhibits significant cracking. Consequently, 6-in.-thick

precast concrete panels were used to overlay the backside of the river wall at Lockport Lock. The concrete base and headcap sections for the panels were also precast. Surface preparation on the existing concrete was limited to removal of loose concrete with a high-pressure water jet. The contractor's bid price for 11,550 sq ft of precast panel was \$21 per sq ft.

Precast concrete panels were also used to overlay the back side of the river wall at Troy Lock. Original plans for repair of this area required extensive removal of deteriorated concrete and replacement with shotcrete. This repair, which would have had to be accomplished in the dry, would have required construction of an expensive cofferdam to dewater the area. Consequently, the New York District decided that concrete removal could be minimized and the need for a cofferdam eliminated if this area was repaired with precast concrete panels.

Three rows of precast panels were used in the overlay. The bottom row of panels was installed and the infill concrete placed underwater. An antiwashout admixture allowed the infill concrete to be effectively placed underwater without a tremie seal having to be maintained. The application of precast concrete in this repair resulted in an estimated savings of approximately \$500,000 compared to the original repair method. Also, the durability of the aesthetically pleasing precast concrete should be far superior to shotcrete, which has a generally poor performance record in repair of hydraulic structures constructed with nonair-entrained concrete.

Guidewall units

The original plan for construction of the downstream guidewall at the main lock, Melvin Price Locks and Dam, was to build a steel sheet-pile cofferdam around the area, dewater the cofferdam and build a conventional reinforced concrete guidewall. However, the need to dewater was eliminated by using precast concrete beams and steel sheet-pile cells to construct the 855-ft-long wall. After completion of the 16 sheet-pile cells, six precast concrete beams were stacked to span between adjacent cells and form the guidewall surface. Each beam was 7 by 8 ft in cross section and 55 ft long and weighed 225 tons. Each beam was designed to resist an impact load of 670,000 lb. Steel armour plate was embedded in the beams during precasting to provide protection from barge impact. The revised construction procedure resulted in an estimated savings of approximately \$7.6 million. A similar procedure was also used to construct the auxiliary lock guidewall.

The upstream guidewall at Bonneville lock is 830 ft long with approximately one-half of the wall floating. Feasibility studies for the floating wall considered all-steel pontoons as well as concrete boxes with steel armor on the channel side; however, designers selected posttensioned concrete box girders precast with 9/16-in.-thick face plates backed by flanged stiffeners. The precast concrete sections, 26 ft deep and 48 ft wide, were designed to withstand a vessel impact of up to 1.3 million lb. The 400-ft-long floating section was fabricated in a single section weighing 8,500 tons in the dry. The

concrete wall was precast in a dry dock upstream of the lock and floated to the project site. The entire job took about 5 months, including 3 weeks for installation.

Dams

The use of precast concrete in repair, rehabilitation, and replacement of dams has increased significantly in recent years. These innovative applications include stay-in-place forming systems for resurfacing dams, gallery construction in RCC buttresses, and underwater repair of erosion-damaged spillways; precast panels to raise the crests and provide wave walls for embankment dams; cellular concrete mats for erosion protection of embankment dams during overtopping; modular sections for partial and complete construction of dams, piers, abutments, and baffle blocks; and preformed caps for parapet walls.

Stay-in-place forms

One of the earliest applications of precast concrete in dam rehabilitation was at Barker Dam, a concrete, gravity structure located near Boulder, CO. The dam was rehabilitated in 1947 to replace deteriorated concrete in the upstream face, correct leakage problems, and improve stability. Rehabilitation of the upstream face of the dam consisted of removing the deteriorated concrete, installing precast reinforced-concrete panels over the entire upstream face, placing coarse aggregate between the dam face and the precast panels, and then grouting the aggregate. Several factors influenced the decision to select this repair method, including: (a) the repair had to be completed between the time the reservoir was emptied in the fall and filled in the spring, (b) the precast panels and the aggregate could be placed in severe winter weather conditions, (c) precasting the panels the summer prior to installation and placing them during the winter reduced the potential for later opening of construction joints, (d) with a protective shell of high-quality precast concrete, a grout with a low cement content could be used for the preplaced-aggregate to minimize temperature rise, and (e) the precast panels were not as expensive as the heavy wooden forms necessary for the placement of conventional concrete.

Resurfacing of the upstream face of the dam required 1,009 precast concrete panels with a total surface area of 8,500 sq yd. Each panel was 8 in. thick, and most of the panels were 6.75 ft wide by about 12 ft long and weighed about 4 tons. The panels were erected, and coarse aggregate for the preplaced-aggregate concrete was placed concurrently during the period January-April 1947. Working conditions during this period were generally miserable with bitter cold and high wind velocities. Concrete construction with conventional methods would have been impractical during this period because of the severe weather conditions. The degree of severity of the weather was reflected in rather large daily variations in the rate of panel

erection; the average rate was about 12 panels per day with a maximum of 27 panels erected in 1 day.

The quality of the work at Barker Dam is considered to be excellent, and the objectives of the rehabilitation program were achieved; however, it is believed that precast panels of much larger size would have resulted in additional economies. With heavy construction equipment, panels up to four times the area could be handled without difficulty and erected at about the same rate as the smaller panels. In addition to reducing the cost of panel erection, larger panels would significantly reduce the total length of joints between panels with a corresponding reduction in the cost of joint treatments.

A drainage gallery system was included in the RCC buttress at Gibraltar Dam to collect inflows from the interface, foundation, and buttress drains. A number of alternative gallery construction methods were considered during design of the system. The designer's preferred method involved compacting an aggregate blockout in the three gallery locations concurrent with RCC placement. However, the contractor elected to use precast concrete panels to form the galleries. The precast panel system had the advantages that no form or backfill removal was required and the galleries were accessible for drilling foundation drain holes during RCC placement. The precast system had the disadvantages of somewhat higher design and material costs and presented occasional obstacles to RCC placing operations.

Precast concrete panels have been used very successfully as stay-in-place forms on the upstream face of several RCC dams. Precast panels provide a finished appearance to the face of the dam as well as providing a durable air-entrained concrete surface. Some precast facing systems were not intended to cut off seepage while others were lined with a continuous PVC membrane to completely block passage of water. Membrane-backed precast panel systems, such as the one used at Winchester Dam, are generally considered to be the most reliable method of reducing seepage in RCC dams. However, there is some concern about the ability of these systems to provide permanent seepage cutoff protection because long-term service records for the membranes are not available.

Precast concrete stay-in-place forms have also been successfully installed underwater. Precast panels and preplaced-aggregate concrete were used to repair spalling in the tailrace slab at Gavins Point Dam. This repair, downstream of the powerhouse, was successfully accomplished by divers working at a water depth of about 50 ft. The contract called for the power plant to be shut down for a period of 14 days; however, the repair was completed in 10-1/2 days. A repair in the dry would have required construction of a very expensive cofferdam resulting in a lengthy power-plant outage.

Panel walls

Precast concrete panels have been used to economically raise the crest or provide wave walls for a number of embankment dams. During design of the

McClure Dam modification, it was determined that precast, prestressed concrete panels were more economical and potentially more durable than steel sheetpiling. A cantilevered wall of precast panels 16 ft 6 in. high by 10 ft wide by 8 in. thick was used to raise the crest of the dam by 7 ft. The 650-ft-long wall was placed in only 10 working days.

Two parallel rows of precast panels with compacted fill between them have also been used to raise the crests of embankment dams. This type of retaining wall system was used by the Bureau of Reclamation to raise the existing crest at Lake Sherburne Dam by 13.5 ft. This patented system, known as Reinforced Earth, uses interlocking precast concrete panels to form walls which are held in place by steel strips embedded in earth fill. A deciding factor in the choice of the retaining wall system was the time required for construction, less than 5 months, which allowed completion of construction in one season. This short construction period greatly reduced the impact on project operations, which were restricted during portions of the construction. The more conventional method of raising the dam by adding embankment would have required two construction seasons and would have restricted reservoir operations during two irrigation seasons. Also, the estimated cost of the precast retaining wall system was \$3.6 million compared to \$5.3 million for adding earth fill over the entire downstream surface of the existing embankment.

Construction of the modification began in July 1982 with excavation of the upper part of the embankment. Panel placement began after completion of the excavation, drainage pipe installation, and placement of the leveling pads for the precast concrete panels. Over 48,000 sq ft of retaining wall was constructed between early August and completion of the work in November 1982. Total contract costs for the modification were approximately \$1.6 million, significantly less than the original estimate. About 65 percent of the cost was for materials and construction associated with the retaining wall structure.

A similar retaining wall system was also used at Googong Dam. More than 1,500 precast panels were used to raise the crest 15 ft to accommodate increased discharges through the existing spillway. This alternative was chosen because it cost less, required a shorter construction period, and would not interrupt the use of the reservoir for supplying water.

Concrete mats

Cellular concrete mat (CCM), precast concrete blocks tied together and anchored, have been used to provide erosion protection for embankment dams subject to overtopping at low flow velocities. All five general contractors that bid on the Blue Ridge Parkway dam modification project proposed to use the CCM system instead of the RCC alternate. Apparently, the bidder's estimated costs for the RCC system were not competitive because of the project's small scale and the requirement to use CCMs at one of the three dams. Approximately 14,300 sq yd of CCM were placed during a 4-month period. The

contractor's cost including overhead and profit was about \$55 per sq yd of CCM.

Gravity units and other components

A hydraulic model of the forebay area at Vischer Ferry Dam showed that head loss and the potential for water separation could be reduced significantly if a contoured pier nose was added at the upstream end of the regulating structure which forms the intake entrance for the forebay. The original design for the pier nose was based on cast-in-place concrete inside a dewatered cofferdam. However, the bid cost for the cofferdam alone was \$250,000, so it was decided to use six precast concrete sections stacked vertically with tremie concrete infill. This method eliminated the need for a cofferdam and resulted in a savings of \$160,000. In addition to reduced construction time and costs, this method effectively eliminated the potentially adverse impact of cofferdam construction on river water quality.

The original plan for construction of the Chauncy Run Checkdams was to use cast-in-place concrete. However, cost estimates in the 30-percent design submission indicated the use of precast concrete could decrease the cost of the dams by 50 percent. In addition, precasting under controlled plant conditions would assure high-quality materials, and it would be easy to maintain flows during construction with the precast concrete components. Therefore, the Baltimore District elected to use precast crib units to form the bulkheads and precast planks supported by precast posts embedded in rock for the dams.

The existing tainter gate piers at Dam C-1 were removed and replaced with precast concrete. The nose and butt units were precast as individual panels, and the remaining pier units consisted of three or four integrated panels. A total of 18 precast units were stacked in three tiers to form the new piers. Low panel fabrication and erection tolerances allowed the original tainter gates to be reused with the new piers.

Hydraulic model tests showed that significant damage to the riprap channel sections downstream of several spillways in the Central and South Florida Flood Control Project was the result of inadequate energy dissipation in the existing stilling basins. Two methods to resolve the scouring action were evaluated: placing baffle blocks in the stilling basins and replacing the existing 18-in. riprap with larger stone. After tests were conducted to determine the optimum size and configuration of the baffle blocks and the size and extent of riprap required, an economic analysis by the Jacksonville District showed that precast concrete baffle blocks would be less costly.

Several alternatives for raising the spillway crest at Fellows Lake Dam were evaluated prior to selection of precast concrete gravity units. Precast blocks, each weighing approximately 7,000 lb, were anchored to the existing crest to increase the height of the spillway by 4 ft. The project was completed in a 5-month period, 2 months ahead of schedule. The total time spent in placing the 350 precast units was about 22 days. The innovative precast

concrete blocks proved to be an economical, efficient, and relatively easy method to raise the spillway crest.

The navigable pass portion of Olmsted Dam will be a 2,200-ft-long pile-supported weir which will incorporate 220 hydraulically operated wicket gates. Traditionally, such a dam would be constructed inside fixed cellular-sheet-pile cofferdams. However, two construction alternates were developed and evaluated: a mobile steel cofferdam for construction of the dam in 200-ft-long increments, and underwater construction of the dam sill and stilling basin with precast concrete. With the mobile cofferdam method, the dam sill would be constructed with precast concrete elements weighing up to 200 tons each and cast-in-place concrete. For underwater construction of the dam sill, a crane barge would be used to lift and install the precast concrete shells weighing 2,600 tons each. Once in position, the precast concrete elements would be infilled with tremie concrete. The stilling basin would be constructed underwater with precast concrete panels and tremie concrete in either case.

Both alternate construction methods offer advantages over the fixed cofferdam method, including (a) earlier initiation and completion of the project, (b) significant cost savings, (c) reduced environmental impact, (d) superior abrasion-resistant concrete surfaces as a result of precasting, and (e) demonstration of an innovative construction technique that can be used on subsequent projects. Although both alternates were found to be feasible, the large precast concrete shells were finally recommended for reasons of safety and greater reuse value of the specialty equipment such as the crane barge.

Precast polymer concrete was used to repair a section of parapet wall at Deadwood Dam, which was suffering from severe freeze-thaw deterioration. Channel sections, 5 ft long with a wall thickness of 3/4 in., were installed on top of the existing wall. After 10 years exposure, the precast polymer concrete exhibits very minor weathering on the horizontal top surfaces.

Channels, Floodwalls, and Levees

Innovative applications of precast concrete in channel, floodwall, and levee improvement projects include linings and overlays for channel walls, retaining walls for channels, partial and complete channel elements, articulated mats for erosion control, a folding floodwall, caps for floodwalls, sill beams for gated levee/floodwall closure structures, and gatewells for levees.

Panels

The contractor elected to use precast concrete panels for the channel walls in the rehabilitation of Placer Creek Channel. Approximately 600 reinforced-concrete panels with typical dimensions of 10 by 15 ft were used in this project. By using precast concrete, the contractor was able to reduce (a) rehabilitation time, (b) excavation requirements, (c) costs associated with the forming system, (d) congestion at the project site, and (e) size of the work

force. This use of precast concrete panels resulted in a savings of approximately \$185,000.

Seepage along monolith and construction joints combined with cycles of freezing and thawing caused extensive deterioration of the exposed concrete in the Joilet Channel Wall. The maximum depth of deterioration was 2 ft, beyond which the interior concrete remained sound. In contrast to the exposed concrete, those sections of the wall insulated from freezing and thawing by backfill had escaped deterioration. Stability analyses, which considered the depth of deterioration, confirmed that the gravity walls founded on bedrock remained stable. Therefore, it was decided that any repairs should provide aesthetically acceptable insulation for the exposed concrete walls to reduce the potential for additional freeze-thaw deterioration. Earth backfill, the most economical method of providing insulation, was not feasible in all reaches because of right-of-way restrictions. Consequently, a precast concrete panel system that included insulation and drainage provisions was used to overlay the existing concrete deterioration. The contractor's bid price for 20,400 sq ft of 10-in.-thick panels including vapor barriers, insulation, anchors, drainage system, concrete footing, and concrete cap was \$19 per sq ft. The aesthetically pleasing repair, completed in 1987, continues to perform satisfactorily.

The process used to stabilize the Mississippi River and keep it from changing course has evolved over the past century from woven willow mats weighted with stones to the present day method of flexible concrete mats. The concrete panels, 4 ft long by 18 in. wide, are precast with stainless steel wires extending from each panel. These wires are tied together to form squares consisting of 16 panels. The mats are transported to a site by barge where the sinking unit ties the squares together to form an articulated mat and lowers them into the water. Approximately 1,000 miles of river bank is being protected with this system with an annual program cost of almost \$100 million.

Because railroad tracks, buildings, and streets were close to the channel banks, two sections of the Mill Creek Local Flood Protection Project required vertical retaining walls. The original design was based on steel sheet-pile walls; however, subsequent geotechnical exploration revealed foundation conditions which precluded the driving of sheet piles. After several alternatives were considered, an anchored post-and-panel wall was selected. The posts were steel H-piles embedded in concrete caissons drilled into rock. Precast concrete panels were used to span between adjacent posts. As a result of the successful construction of approximately 7,000 bank-ft of retaining wall under restrictive conditions, this type of wall is recommended for similar applications.

A portion of the Bettendorf, IA, Local Flood Protection Project passes through an area developed as a park. City officials wanted the project to have a minimal impact on the aesthetics of this area; therefore, a folding floodwall was selected for this portion of the project. The wall consists of three sections: a permanent, concrete lower section; a hinged, precast concrete mid-section; and a hinged, aluminum top section. The precast midsection is a

6-in.-thick, reinforced concrete panel, 3 ft 5 in. high, attached at its lower edge by the hinges connected to the lower permanent wall. Typical precast concrete panels are 18 ft 10 in. long with a weight of approximately 6,600 lb.

When the panels are in the folded position, the exposed portion of the fixed lower section does not obstruct the view of the Mississippi River. When high flood levels are expected, the panels are unfolded and supported by steel pipe struts. Monolith and panel joints are sealed with rubber seals and closure plates. The innovative design of this floodwall provides the required degree of protection with minimum visual impact.

Channel elements

The original design for the low-flow channel section at Blue River was a pair of steel sheet-pile walls with a cast-in-place concrete strut. However, concern about driving piles in an area with steel smelting slag and other industrial debris prompted design of a precast concrete alternative.

The estimated cost of construction for the sheet-pile channel was \$6,035,000 compared with \$8,970,000 to \$11,651,000 for the precast concrete channel depending on how the river water was handled during construction.

There were seven bidders on the project, and all bids were based on the precast concrete alternate. The low bidder's estimate for the low-flow channel was \$2,000,245, far less than the Government estimate. During discussions, some of the bidders indicated that their estimates showed that the cost of constructing the precast concrete channel would be about \$2,000,000 lower than that of the sheet-pile channel. Their estimates were based on placing 8 to 10 precast sections per day compared to the Government estimate of 2 sections per day. In fact, the 700 precast sections were installed with daily placement rates ranging from 12 to 46 sections. The major advantages of precast concrete in this application included low cost, rapid construction, and ease of construction. Also, the use of precast concrete allowed the contractor to divert river water into the channel sections immediately following installation which significantly reduced the cost of water control during construction.

Precast concrete units were used extensively in 29 major channel expansion projects to alleviate flooding problems within the Sydney metropolitan area. Precast box units up to 16.4 ft wide and 6.5 ft deep were installed by jacking under busy urban streets and railway lines. This procedure minimized traffic disruptions and was much faster than the traditional open-trench method for channel construction. In tidal channels, where each operation had to be completed during low-tide periods, the rate of channel construction was dramatically increased by installing precast units up to 11.8 ft wide by 10.8 ft deep and 4 ft long on prepared foundations. In some projects where the available easement permitted channel enlargement, L-shaped precast units were used to accelerate construction.

Installation of the precast units on prepared foundations essentially eliminated the need for temporary shoring and supports, thus increasing the rate of construction. Also, the installed precast units could be used immediately to safely handle flows associated with unexpected storms. As a result of the innovative design and construction methods used in these projects, the total cost of the program was \$61,000,000, which was \$20,000,000 less than the original estimate.

In October 1992, a major forest fire in El Dorado County, CA, destroyed about 1.25 miles of wooden flume used to carry water to a hydro-electric powerhouse and to a local irrigation district. Because of the rough terrain and limited access to the canal, the replacement flume was to be installed with helicopters; thus the weight of individual sections was limited to 11,000 lb. A feasibility study indicated that the weight restrictions could be satisfied by precasting the units with lightweight concrete in 8-ft lengths.

Since reconstruction had to be completed by 1 December 1993, proposals were solicited from a select list of contractors to design and construct the 700 sections required for the project. The selected contractor procured 310 lin ft of steel forms which permitted precasting of 31 flume units daily. The flume units were transported by truck from the precasting facility to a staging area near the site and then transported to the site by helicopter and lowered directly onto previously installed foundations. This method of installation proved to be very successful, and the helicopters were usually able to make a round trip in less than 7 min. All of the precast units were in place by late November 1993.

Wall elements

Interlocking precast concrete modules stacked on top of each other and filled with compacted fill were used to form a gravity wall along the West River in New Haven, CT. The aesthetically pleasing curved wall is 16 ft high and approximately one-quarter mile long. Since the wall is located in an urban area, a river walk was created by constructing a sidewalk with fencing and lighting on top of the wall.

Various prefabricated wall systems were researched and evaluated for potential use in construction of the River des Peres channel wall. The five wall systems selected for design were: Armco Bin-Type, Doublewal, Mechanically Stabilized Earth, TechWall, and WaterLoffels. Cost comparisons were made based on quantities of excavation, backfill, premanufactured materials, and other items pertinent to each type of wall. Currently, it appears that the mechanically stabilized backfill wall will be used to construct the channel wall because it is considered to be the most cost-effective.

As part of the overall rehabilitation of the Hornell Local Flood Protection Project, the concrete floodwalls were repaired by removing the deteriorated concrete and replacing with shotcrete. The engineers who designed these repairs, while satisfied with the general quality of similar work in the past,

felt that the aesthetics of such repairs left room for improvement. Consequently, they designed a precast concrete capstone to be used in combination with shotcreting of the vertical wall surfaces. The precast concrete caps were anchored to the top of the wall prior to shotcreting of vertical surfaces. The regular shape and overhang of the capstones greatly enhanced the appearance of the approximately 875 lin ft of floodwall repaired in this manner.

Raising the Pineville Levee and addition of a floodwall along the crest required construction of nine closure structures. Two of the gated closure structures were across railroad tracks. A typical closure structure consists of a concrete sill beam beneath the tracks with piers on either side projecting out of the sill and a gate hinged to one of the piers. Conventional construction of the sill beam with cast-in-place concrete would have taken the railroad out of service for an unacceptable period. Also, site conditions were not favorable for construction of a run-around. Therefore, an innovative closure structure was designed to allow construction with minimal impact on railroad operations. This design consisted of piers on each side of the tracks with their own separate bases and a precast reinforced-concrete sill beam beneath the tracks, the ends of which rest on seats in the pier bases.

To allow time for installation of the precast-concrete sill beam, the railroad rescheduled some trains, and the construction crew worked on a holiday. This effort provided approximately 18 hr of uninterrupted construction time. However, the installation went so smoothly that the contractor completed the entire operation with more than 7 hr remaining before the next train was due. This innovative design and construction method allowed the closure structures to be completed without disrupting railroad operations. It also eliminated the extensive work and expense required to construct a run-around. As result of the success of this project, a similar design with precast concrete sill beams was used for the protective works at Harlan, KY. Also, a modified version of the design is currently being used at Barbourville, KY.

Gatewell

The original design of the Chouteau Island gatewell was based on cast-in-place concrete; however, the contractor elected to use a precast concrete, two-section gatewell with the same dimensions and reinforcement as the original structure. Preassembling the gatewell with all appurtenances at the precast yard provided an opportunity to correct any problems before delivery. Also, the field team was able to have a "practice" installation before performing the field installation. Since the compatibility of the various components was demonstrated prior to delivery on site, field installation was greatly facilitated.

Coastal and Offshore Structures

Beaches are economically important to many coastal communities because of tourism and beach-front development. Waterways provide an economical way to transport goods and freight. For these reason, a considerable amount

of research has been done in an effort to develop some means of halting or slowing erosion along beaches and navigable waterways. Precast concrete is used in the construction of many of these protective systems because precasting offers several advantages: modules for armor systems can be constructed and stockpiled so that they are readily available; the concrete mixture can be proportioned with a generous cement content and a low water-cement ratio, making it more durable than conventional concrete; under most circumstances units can be placed independent of tidal conditions and without the usual formwork and concrete placing and stripping; the modules can be removed and reused; and the concrete provides necessary weight to resist strong tides and currents.

Modular armor systems

A proprietary concrete armor system consisting of precast modules known as STA-PODs has been installed at Cross Bay Parkway Bridge in Queens, New York, to protect the slope near the bridge from high tides. At nearby Fire Island, a single line of STA-PODs is helping to stabilize the beach. Tests performed by WES have shown the system to be stable in tides slightly over 7.5 ft because of the interlocking design of the modules and "legs" that sink into bottom material. Another precast concrete interlocking modular system, Seabees, has been installed near Skegness on the most exposed area of coastline in Lincolnshire, England. Seabees are 1-ton, hexagonal, nut-shaped modules. They form the outer layer of a rock revetment. Although they do not weigh as much as the rocks beneath them, their hexagonal shape allows them to be interlocked to provide stability, and their nut-shape is in keeping with NRA's plan to provide a defense system that absorbs energy rather than reflects it.

Erosion control systems

Available proprietary systems designed to slow or halt beach erosion include Beachcones, Beach Beam, and a precast concrete reef. Each of these systems is designed to diminish wave energy, encourage sand accretion, and stabilize accreted sand. They are installed along the beach so that tides wash over their tops. Compared to the cost of dredging ocean sand, building a breakwater, or pumping or trucking in sand, the systems are cost-effective.

Beachcones have been installed in Louisiana, Mississippi, and Alabama. The modules, which are shaped like a center section of a cone open at both ends, are fitted together with a Waveblock to form configurations of various sizes and lengths. When Hurricane Andrew swept across Shell Island, LA, areas where Beachcones were installed did not wash away; adjacent areas without the Beachcones did. After Beachcones have rebuilt an area of beach, they can be removed and used elsewhere. Cost of a Beachcone system in 1992 ranged from \$50 to \$100 per ft of shoreline.

Beach Beam is a rectangular precast concrete structure with a concave surface with openings through which sand can pass. Beach Beams have been installed in the Chesapeake Bay area, the inland waterway in Florida, and at Wallops Island, VA. NASA reported a 4-ft accumulation of sand behind the units being tested in Virginia.

A precast concrete reef system has been installed at Sea Isle City, NJ. The system consists of individual "reefs" placed side by side. Weight and "feet" on the bottom of each module help provide stability. The reefs are precast with silica-fume concrete, which provides an impact resistance 10 times greater and salt resistance 20 times greater than that of conventional concrete. The average cost (1991) for a linear foot of the man-made reefs is \$600.

A concrete-block revetment with two concrete sheet-pile wall segments is planned for an 8-mile strip of the GIWW near Sargent Beach, TX, in an effort to prevent further erosion of the area and to keep the GIWW open. The biggest threat to the shoreline is the rough waters of the Gulf of Mexico, which will be admitted to the area in the near future as the barrier island currently providing protection is being breached by erosion. The protective structure will be built in-the-dry to ensure proper installation. After excavation and grading of the slope are complete, the slope will be covered with a 2-ft layer of 1/2- to 200-lb blanket stone. The blanket stone will be covered with a layer of precast concrete blocks sized to keep the entire revetment stable under storm conditions.

Precast Panels

Precast concrete panels have been used in repair and construction of marine structures. A proprietary system, Stresswall, was used to repair the seawall at Pacifica, CA. The system consists of L-shaped tie-backs and wall panels. A tie-back has a T-shaped front that rests on a base which is extended back into backfill. Panels are placed between the tie-backs to complete a wall section. This system is fast to install because it uses no mechanical fasteners, requires no special equipment for compaction of the backfill, and uses no cast-in-place concrete. Typical costs range from \$11 to \$14 per sq ft (1989 prices) for material delivered to the jobsite.

The contractor for a lake-front development in Cleveland, OH, used precast panels to extend a seawall into Lake Erie to create a lagoon. Originally, the contractor had planned to tremie the seawall to avoid the cost of dewatering. Later he decided to use precast panels and install them in-the-dry. However, he realized a dry installation would add approximately \$500,000 to the cost of the job, so he devised a way to lower the groundwater enough to install the panels without dewatering.

Precast concrete panels were used to replace the original masonry quayside walls along the River Tawe near Swansea, Wales. The Swansea City Council determined that a geogrid, reinforced soil structure with full-height precast concrete panels was the most cost-effective repair method. Short tails of the

geogrid were attached to the concrete panels during casting. The tails were then attached to the geogrid with a needle joint. After the geogrids were tensioned, they were filled with soil and compacted.

Artificial reefs

Precast concrete was selected for construction of artificial reefs to be used in a 3-year study being conducted in the Indian Ocean near Sri Lanka. The artificial reefs are being used in an effort to promote reef recovery in areas where coral reefs have been stripped away by mining. Precasting allows the blocks to be constructed ahead of time, transported to the area where they are needed and placed with a crane. A visual inspection of the reefs after approximately 7 weeks revealed most of the concrete surfaces to be inhabited by benthic organisms, including algae, bryozoans, sea quirts, hydroids, sponges. Coral had begun to colonize on the SHED precast concrete blocks. A similar project is being conducted in Poole Bay, the United Kingdom, to help increase fish and shellfish populations, thus increasing the size of catches. This project is also providing an alternative for waste-product disposal as the blocks are being precast with waste products from coal-fired power plants and cement.

Precast components for berms, wave deflectors, and other components

The use of precast components allows a contractor to control material properties and construction so that critical specifications for alignment and installation can be met, thus saving construction time. A berm, part of a sea defense structure installed at New Biggin by the Sea, England, had to be constructed in a tidal zone. By using precast components, the contractor was able to complete the job in almost half the estimated time, despite the tides. Six precast components were used to construct a wave deflector on a breakwater at Clyde Quay Boat Harbor, near Wellington, New Zealand. This project was completed in only 3 days.

Precast concrete components were used in the construction of a floating breakwater at Chaffers Marina, New Zealand. The 656-ft-long breakwater consists of precast "H"-shaped segments, which were constructed and prestressed in a temporary dry dock. Each segment has a polystyrene core. A galvanized steel reinforcing cage was constructed around the core prior to its being positioned in the formwork. When the segments were completed, they were moved into the water, towed to the location designated for the breakwater, and posttensioned together. The breakwater was then anchored to seabed piles with chains. The quality control allowed with the precasting enabled the engineer to meet specifications so the breakwater would float at the proper height.

The contractor extending the smelt raceways for Southern Ocean Salmon near Takaka, New Zealand, elected to use precast concrete tilt slabs for the walls and in situ concrete for the bottom of the raceways. The cost for the

panels was estimated to be the same as the cost for forms alone for cast-in-place walls.

Precast brackets, columns, and cornices were used in the rehabilitation of Brandywine Shoal Lighthouse, New Jersey, and in construction of a cofferdam for a sewer pumping station at Wallasey, England. The cofferdam, which was located on a reclaimed beach, was constructed of precast concrete units that were designed to destroy wave energy and reduce wave deflection. Each unit consisted of two columns on the front, a base slab, top, and rear wall. The columns were cast separately ahead of the main units, which were cast on the side. Engineers felt side-casting was the best method for achieving accurate dimensions and well-compacted concrete and for reducing the risk of nonstructural cracking.

Bridges, Culverts, and Tunnels

Advantages of using precast concrete modules in repair, rehabilitation, and construction of bridges, culverts, and tunnels include economy and speed. Precasting eliminates the expense of onsite batching, placing, and curing. It provides a durable product through quality control. Casting can be done in "off season" or concurrently with preparatory work. Standardized units can be stockpiled for immediate use when needed.

Aging structures

Contractors have elected to use precast components to rehabilitate aging bridges whose aesthetic appeal is important to their communities. By using precast components, contractors can maintain the proportions of the original bridges and duplicate texture and color. The 145-year-old Jediah Hill Bridge near Cincinnati, one of the remaining covered bridges in the country, the Dublin Scioto Bridge near Columbus, OH, a 1935 WPA project, and the 90-year-old Maria Cristina Bridge in San Sabastian, Spain, were all rehabilitated with precast concrete components. The rehabilitated structures are more functional and stronger, and they have the same proportions and appearance as the original structures.

Short-span bridges

The Florida DOT and the Center for Local Government Technology at Oklahoma State University have been conducting separate studies to determine the best method for replacing short-span bridges. The Florida DOT has been experimenting with a precast slab-type bridge replacement that can be standardized and stockpiled for use in both new construction and replacement of deteriorated structures. Concerns identified in the study include fatigue behavior, durability of connections, and long-term durability of grout or epoxy mortar. For bridges between 20 and 25 ft, the Oklahoma study recommends a precast short-span replacement constructed with reinforced concrete

beams laid side by side and bolted together. The first bridge of this type installed in Oklahoma was in Pottawatomie County near Shawnee. Total cost for this bridge was \$30,600, excluding forms (1985 costs). A second bridge has been installed in Pottawatomie County and one in Osage County. The Center feels this method of bridge construction will be cost-effective, will require a short construction period as spans can be fabricated during the winter months, and will increase load-carrying capacity of short span bridges. Reusable steel forms cost about \$4,500 per pair (1985 costs). The Center recommends the use of a jig table to ensure exact placement of reinforcing.

Precast concrete deck slabs

Many bridges in need of rehabilitation are located in heavy traffic areas where no alternate route sufficient to handle the traffic is available. A viable option for such projects is the use of precast concrete slabs for deck replacement. The slabs can be installed in a short period of time and are usually ready for traffic immediately after installation.

Traffic on the High Street Overhead in Oakland, CA, averages about 170,000 vehicles per day. By using precast concrete slabs to replace the deteriorated deck, the contractor kept some traffic lanes open all of the time and all of the lanes open during peak traffic hours. Precasting was done in the right-of-way next to the jobsite. The deteriorated decking was cut into large sections that were lifted off with a crane and replaced with new sections. The bridge was ready for traffic as soon as the new sections were installed.

Traffic on the Woodrow Wilson Memorial Bridge in Washington, D.C., averages 110,000 vehicles per day, with as many as 5,000 vehicles traveling one way in an hour during peak periods. Using precast concrete slabs enabled the contractor to replace the old decking without interrupting traffic during peak hours and without closing the bridge at any time. One innovation that speeded up construction was the use of steel grates as temporary replacement for removed-but-not-replaced bridge sections. Workers could remove more slabs than could be replaced during a work period; using the steel grates allowed the bridge to remain open for traffic and workers to begin placing precast slabs at the beginning of each work shift. The cost for this project was approximately \$9.2 million below the engineer's estimate, and the project was completed 255 days ahead of schedule.

When an inspection showed the Fremont Street Bridge, Pennsylvania, needed to be repaired, PennDOT decided to widen the bridge at the same time. While the work was being done, the contractor had to keep two lanes open for traffic and maintain access to nearby businesses. Keeping the two lanes open meant the floor beams would have to be cut in half and support provided for the half of the bridge remaining in use. The contractor chose to use precast concrete floor beams because they minimized shoring and formwork and allowed for efficient connections. He used precast concrete slabs for deck replacement because they are less weather dependent and they are ready for traffic in a short time. In Phase I of this project, which required

1 week, 300 ft of decking was installed and ready for traffic. Phase II was similar to Phase I except that the transverse posttensioning bars were extended across the entire deck; the approach at the center of the roadway was completed in Phase III, and appurtenances were installed during Phase IV.

Precast concrete slabs were used to replace deteriorated decking on the Freemont River Bridge in Maine, the Connecticut and Chicopee River Bridges in Massachusetts, the Pennsylvania Turnpike, and the crossing at Krumkill Road in New York. The decision to use precast concrete slabs in each of these projects was based on the need for speed, economy, and safety.

Bridge accoutrements

The Ulsterville Bridge in New York was constructed over a trout stream. By using precast concrete components for the abutments and deck, the contractor was able to minimize onsite construction activities and complete the job in a matter of days without disturbing the stream to any significant degree. Modules that fit together to form a sealed, monolithic-like effect were used to construct the abutments. Each module was cast with a back cavity that was filled with earth to create a gravity retaining wall. Deck units were cast upside down in forms suspended from wide flange steel girders so the weight of the forms and the concrete would produce a prestressed effect on the girders and the densest, least permeable concrete would be on the wearing surface.

To reduce construction time and increase safety, precast concrete cofferdams, which were later incorporated as pier stems, were used in the construction of a bridge over the Colorado River near Glenwood Canyon. The supporting piers rest on caissons drilled into bedrock. The original plan was to cast the piers in place; however, the tops of some of the caissons were 20 ft underwater. The contractor modified his plans to use the cofferdams as permanent bases for the pier stems. Reusable forms were used for casting the sides of the cofferdams, which ranged from 5 to 20 ft high. The taller units were cast first, and then the forms were cut down for the shorter units. Completed cofferdams were lowered in place with a crane. After they were filled with tremie and conventional concrete, the cast-in-place pier stems were constructed on top of the cofferdams. The project, which consisted of a 631-ft bridge and a 1,000-ft approach road, was completed in 14 months at a cost of approximately \$3.8 million (1987 costs).

The Pennsylvania Turnpike Commission decided to replace the concrete island curb on the Susquehanna Bridge as a part of a major bridge rehabilitation program. The Commission investigated several replacement alternatives before electing to use precast polymer concrete shells to construct a median barrier. Polymer concrete was selected because of its high strength and high modulus of elasticity and its resistance to cycles of freezing and thawing, deicing salts, corrosive chemicals, and oil. The median barrier shells were cast in 20-ft lengths for easy handling. A three-man crew unloaded the shells, positioned them on the bridge, and anchored them with 0.375-diam anchor bolts. The precast polymer shells, which were then filled

with conventional concrete, are four times stronger than a conventional concrete barrier would have been. The 4,900-lin ft barrier was installed in approximately 3 months.

Railroad bridges

Precast concrete components offer speed, economy, and durability in repair and construction of railroad bridges. Standardization of components reduces the amount of time needed for project design and construction. Reduced construction time is an economic necessity for railroads. Estimated cost for 1 hr of train delay runs as high as \$400; closing one bridge can impact an entire system. Additionally, control of materials and workmanship provides greater durability.

The use of precast concrete does present some problems. Weight is the primary disadvantage. Piles are difficult to install with track-mounted equipment with limited lifting capacity and reach. Also, cycles of freezing and thawing and differential settlement of pile caps have caused problems. Precast spans are hard to repair, especially under time restraints. However, many railroad bridges are located in remote areas with access so limited that precast concrete components offer the only cost-effective option.

The Santa Fe Railroad system replaced all timber bridge decking on steel girders with precast concrete slabs. Precast concrete slabs were selected because they provided a watertight surface to protect the steel and painted areas in the substructure. Bonding the concrete slabs to the steel girders strengthened the spans. Stress tests conducted before and after the installation of the slabs showed a 50-percent reduction in stress for the top flanges and 11 percent for the bottom, even with the additional weight of the concrete.

The Southern Pacific Railroad used precast concrete box girder spans as part of the replacement structure for a 90-year-old railroad bridge. Precast, prestressed box girders were used in construction of bridge piers and as replacements for the timber trestle and the steel-plate girder span. Two 30-ft box girders were placed side by side for each span in the timber trestle area. Each steel truss was replaced by two spans, each span consisting of four precast concrete box girders. The concrete would require minimum or no maintenance.

Culverts

Precast concrete culverts offer several advantages: they can be installed in a short amount of time, they are easy to add on to, and they can be moved to another location should the need arise. Also, they can be precast ahead of time and stored until needed.

Time is one of the primary reasons contractors choose precast concrete culverts. At Fort Sill Army Base, 46 precast, reinforced-concrete boxes were

installed in 2-1/2 days. In North Dakota, 126 ft of double-cell boxes were installed in 2 days. The day after this project was completed, 16 in. of snow fell. In New Jersey, the contractor on a project to replace a double-barrel, earth-filled brick arch culvert agreed to meet a 14-day schedule. The project was located where South Orange Avenue crosses the west branch of the Rahway River. Since the avenue runs through a parkland, the contractor decided not to build a detour road. The inside dimensions of the new culvert are 20 ft wide, 4 ft high by 68 ft long. By using precast units, the contractor had to close the avenue for only 2 weeks and saved the taxpayers a minimum of \$250,000.

Instead of removing two partially collapsed metal culverts, NYDOT decided to rehabilitate them with precast concrete pipe. The culvert near Nyack was under 120 ft of cover; the one in Monsey was under 105 ft of cover. The culverts had a 60-in. diam; the pipes, a 42-in. diam. After debris was cleaned from the culverts, steel channels were installed to serve as tracks for the pipes. A winch and a system of pulleys and cables were used to pull the pipes into the culverts. Once the pipes were in place, concrete mortar was pumped into the space between the pipe and the culvert. The pulling system was better than jacking because it reduced the pressure load on the last section of pipe and eliminated the need for a structure to provide leverage; also, pulling through a culvert's bends and inclines is easier than jacking through them.

Tunnels

Precast components have been used to expedite rehabilitation and construction of tunnels. The use of precast components reduces construction time, facilitates working around traffic demands, and reduces field labor costs. Precast concrete ceiling panels were used to replace the deteriorated panels in both tubes of the Holland Tunnel, which connects New York City with New Jersey. Repairs were made to one tube at a time. Most of the work was done at night so traffic operations could resume during the day.

A precast concrete arch-tunnel system was selected for construction of the St. Hubert Tunnel in Quebec, Canada. St. Hubert is a part of Quebec's \$300-million urban transformation project. Major advantages of the precast concrete arch system are that it requires a short time for construction and few workers. Four workers, including the crane operator, completed the tunnel in six 8-hr shifts. This same system was used to build a tunnel in Malaga, Spain. After construction had begun, the contractor added another lane to the double-arch structure that had been specified. The cost for the Malaga project was approximately 17 percent less than the cost for a cast-in-place system with precast beams would have been. The Malaga tunnel was completed in 4 months; estimated time for the other systems was at least 8 months.

A polymer concrete mixture was used in the rehabilitation of Sumner and Callahan Tunnels in Boston. Polymer concrete was chosen because it has a high compressive strength, approximately 15,000 psi, and a high modulus of

elasticity. Because of the high strength, polymer concrete components are thinner and, therefore, lighter than conventional precast concrete panels. The size and weight were important factors in their selection for the repair of Sumner Tunnel. Conventional precast panels would have extended too far into the roadway and would have been too cumbersome for the limited work space. Also, the polymer forms an impenetrable barrier, making the panel surface resistant to cycles of freezing and thawing, salts, corrosive acids, and chemicals, and it is unaffected by detergents, brushes, and high-pressure water jets used in cleaning the tunnel walls.

Precast polymer concrete panels were used as stay-in-place forms for rehabilitation of the bench walls in Sumner Tunnel. These panels were also reinforced with fiberglass, making them even stronger and more resistant to impact. Construction was done between midnight and 5:30 a.m. so both lanes of the tunnel could be kept open during the day. Panels were placed, anchored to the wall, and backfilled with a concrete mixture containing a superplasticizer. The vertical joints were sealed and the anchor holes plugged. Twelve men installed approximately 36 panels per shift.

Because of the performance of the polymer concrete panels in the Sumner Tunnel, contractors elected to use polymer concrete to repair the deteriorated sidewalls and to rebuild the bench walls in Callahan Tunnel. The precast polymer panels were used as cladding for the deteriorated sidewalls and as stay-in-place forms for the bench walls. The panels have a 40-mil white gel-coat surface that was fused to the panels during casting. This coating makes the panels reflective, much like ceramic tile. The hard finish makes them resistant to impact from traffic accidents.

Retaining Walls and Noise Barriers

The use of precast concrete panels and posts for construction of retaining walls and noise barriers offers several advantages, such as quality control of materials and fabrication, reduced construction time, moveability, durability, and aesthetics. Also, they are cost-effective.

The Indianapolis Power & Light Company elected to use precast, prestressed concrete panels to replace two 15-year-old steel sheet-pile walls at their coal storage facility. A primary reason for the contractor's choosing the precast concrete panels was that they could be installed within the specified time frame for the project. In addition, the concrete would not be susceptible to coal leachates, and the smooth face of the panels would facilitate compaction of the coal, thus reducing the number of voids, which are sources of spontaneous combustion. Total cost of the project was \$690,000; cost for the precast, prestressed concrete was \$250,000 (1984 prices). The combined surface area of the walls was 8,408 sq ft. The project took 4 months to complete.

In Massachusetts, a general contractor for a three-level shopping mall contracted out construction of a retaining wall around the mall site. The contractor for the retaining wall used a cast-in-place foundation block and base slab and precast panels to construct the retaining wall. One hundred sixty-six 4-ft-wide panels used in the project were erected between December 12 and January 6, when the temperature was zero degrees at some times. The short installation time and the ease of dismantling the structure were two advantages of using the precast retaining-wall system.

The need for noise barriers along roadways is increasing as suburban areas continue to extend out from cities. These areas create traffic congestion which is relieved only by construction of freeways through these residential sections. The freeways become sources of vehicular noise that often exceeds the "acceptable" level. Noise barriers become the solution to this type of problem. Noise, or acoustic, barriers are generally classified as reflective, dispersive, or absorptive. The type of barrier to be used is determined by the area in which it is to be located. Noise barriers constructed of precast concrete are durable (life expectancy is a minimum of 40 years), require little maintenance, and are cost competitive. In addition, they can be finished in a variety of ways that make them aesthetically suited to their setting.

In 1987, NJDOT installed 17,000 lin ft of precast concrete panels along Interstate Route 80 in Morris County to serve as a noise barrier. Concrete was chosen for its durability and its aesthetically pleasing appearance. The ground installation consists of I-shaped, precast reinforced concrete posts and panels. To extend the wall along existing bridges that crossed local roads, the contractor chose to construct a steel and concrete support system for the walls. This method was more practical and cost-effective than replacing the existing bridge beams with longer beams that would extend out from the bridge to provide support for the wall. To make the noise barrier fit the surroundings, the panels were textured on the residential side and left smooth on the traffic side. The cost for the ground-mounted barrier walls was \$18 per sq ft; for the independent structures, \$88 per sq ft (1987 prices). Because of the success of this project, NJDOT elected to use the same method on another section of Interstate Route 80. The new section will total 35,000 lin ft and 752,000 sq ft.

A similar system was used to construct the half-mile Kildonan Corridor Noise Attenuation Barrier in Winnipeg, Canada. The barrier, which consists of precast concrete columns and wall panels, some of which were cast with murals, required no hardware for installation. The City of Winnipeg elected to use precast concrete components because of speed of construction--the entire project was completed within 3 months--precasting the panels with art work was easier than site casting them would have been, and precasting reduced congestion at the project site and was more cost-effective than site casting.

Concrete Paving Blocks

Precast concrete paving blocks are being used to construct a flexible pavement that is durable and requires very little maintenance. The paving blocks, typically cast from a mixture of well-graded aggregates and hydrated portland cement, are placed by hand on a restructured foundation of soil, stone, and sand and then compacted. The pavers, which are about the size of a common brick, can be cast in a variety of shapes and can be mass produced.

In 1990, the Dallas Fort Worth International Airport Planning and Engineering Department used interlocking concrete pavers to construct taxiways as a part of their capital improvements program. The pavers were selected because they could withstand heavy loads and harsh weather; allowed the taxiways to be constructed during 12-hr closures with only 30 min required to remove workers, equipment, and material from the construction site; and were ready for traffic immediately after installation.

Precast concrete pavers were also installed at the Aberdeen Proving Ground, MD, in 1989. The project site is located on the outer rim of the Tank Retrieval Range Area at an intersection for five range roads. Approximately ten 56-ton tank retrievers and ten 30-ton tracked vehicles used the unsurfaced intersection each day. The area was excavated and then replaced with subbase fill, a layer of crushed stone, and a layer of bedding sand to form a foundation for the pavers. A 3-1/2-in. concrete curb was cast-in-place around the area before the pavers were placed. The same day the pavement was completed, it was tested with a 56-ton M-88 tank retriever. The test included low-speed straight passes, high-speed braking and acceleration, 90-deg pivot steer turns, and 360-deg pivot steer turns at high speed. The blocks were undamaged. An 8-month inspection revealed some wheel rutting but no loss of structural integrity. An inspection after 1 year of service determined the blocks were in good condition. Total cost of the project, including all subbase and base work and the geotextile fabric, was \$126,743. Costs for the materials, labor, and equipment for the paving blocks was approximately \$4.30 per sq ft (1989 prices). The design life for the concrete block pavement is 20 years.

PSC/LAW Engineering of Beltsville, MD, studied the use of concrete pavers for roads and sidewalks in North Bay, Ontario, Timmins, Ontario, and Fayetteville, NC. In both locations in Ontario, the pavers were placed on a base of crushed aggregate topped with bedding sand. In North Carolina, the pavers were placed on a base of 8-in. aggregate covered by 2 in. of asphalt topped by bedding sand. Temperatures in Ontario range from -40 °F to 96 °F with large amounts of rain and snow. Approximately 300 tons of salt and sand are used on the streets each winter. In North Carolina, temperatures range from -29 °F to 110 °F; precipitation averages 19 in. per year with very little snow. Roads in all three cities where the pavers are installed have heavy traffic, including buses and trucks. The study revealed that the modulus of elasticity of the pavers and bedding sand increased as the traffic load increased. Additional advantages the pavers have over asphalt are that they are

not affected by heat and excess loads, they are not subject to cracking from loads and weather, and replacing a paving block has no effect on the rest of the pavement surface. The PCS/Law Engineering study concluded that well-constructed and correctly installed precast concrete pavers have advantages over conventional pavements used in urban areas.

4 Conclusions

Applications of precast concrete in repair and replacement of civil works structures have increased significantly in recent years, and this trend is expected to continue. This review of these applications shows that, compared with cast-in-place concrete, precasting offers a number of advantages, including ease of construction, rapid construction, high quality, durability, mobility, and economy.

Precasting minimizes the impact of adverse weather. Concrete fabrication in a precaster's plant can continue in winter weather that would make onsite cast-in-place concrete production cost prohibitive or impossible. Also, precast concrete can be installed underwater and in weather or tidal conditions where construction with conventional cast-in-place concrete would be impractical.

Concentrating construction operations in the precaster's plant significantly reduces the time and labor required for onsite construction. Reducing onsite construction time is a major advantage in repair of structures such as bridges and navigation locks where delays and shutdowns can cause significant losses to the user. Standardized units can be precast and stockpiled for immediate use when needed. Also, rapid construction minimizes the potential for adverse environmental impact in the vicinity of project sites.

Although the quality and durability of precast concrete is not necessarily better than concrete cast-in-place at the project site, a qualified precaster usually has the advantages of a concentrated operation in a fixed plant with environmental control; permanent facilities for forming, batching, mixing, placing, and curing; well-established operating procedures, including strict quality control; and personnel with experience in the routine tasks performed on a daily basis. Also, precasting makes it possible to inspect the finished product prior to its incorporation into the structure.

Precast concrete elements are easily transported by a variety of conveyances, including trucks, trains, barges, etc., and under some circumstances structures can be disassembled and components reused.

Ease of construction, rapid construction, and repetitive use of formwork all contribute to lower construction costs with precast concrete. Also, underwater installation of precast concrete eliminates the significant costs associated with dewatering of a hydraulic structure so that conventional repairs can be made

under dry conditions. As the number of qualified precast suppliers continues to increase and as contractors become more familiar with the advantages of precast concrete, it is anticipated that the costs of precast concrete will be further reduced.

References

- ACT Electricity and Water. (1991a). *Googong Dam remedial works design report*, Queanbeyan, New South Wales.
- _____. (1991b). *Googong dam remedial works construction report*, Queanbeyan, New South Wales.
- ABAM Engineers, Inc. (1987a). "A demonstration of the constructibility of a precast concrete stay-in-place forming system for lock wall rehabilitation," Technical Report REMR-CS-14, U.S. Army Engineer Waterways Experiment Station, Vicksburg, MS.
- _____. (1987b). "Design of a precast concrete stay-in-place forming system for lock wall rehabilitation," Technical Report REMR-CS-7, U.S. Army Engineer Waterways Experiment Station, Vicksburg, MS.
- American Association of State Highway and Transportation Officials. (1978). "Precast concrete elements for transportation facilities," Transportation Research Board Report 53, National Research Council, Washington, DC.
- _____. (1987). "Standard specifications for structural supports for highway signs, luminaries, and traffic signals."
- American Society of Civil Engineers. (1984). "Redecking with precast keeps traffic moving," *Civil Engineering* 54(1), 46-50.
- _____. (1988). "Precast panels repair storm damaged seawall," *Civil Engineering* 58(4), 98.
- _____. (1989). "Engineering applications: precast culvert replaces old arch in Kentucky," *Civil Engineering* 59(1), 84.
- _____. (1992). "French system tunnels into Canada," *Civil Engineering* 62(8), 10.
- American Society of Civil Engineers. (1993). "Concrete reef may return sand to beach," *Civil Engineering* 63(10), 12.

American Society of Civil Engineers. (1993). "Final report on wind forces on structures," ASCE Paper No. 3269.

American Society for Testing and Materials. (1991). *1991 Annual Book of ASTM Standards*, Philadelphia, PA.

- a. Designation C 33, "Standard specifications for concrete aggregates."
- b. Designation C 789, "Specifications for precast reinforced concrete box sections for culverts, storm drains, and sewers."
- c. Designation A 706, "Standard specification for low-alloy steel deformed bars for concrete reinforcement."
- d. Designation D 1056, "Specifications for flexible cellular materials, sponge and expanded rubber."
- e. Designation C 936, "Standard specification for solid concrete interlocking paving units."

Anderton, G. L. (1991a). "Concrete paving blocks: facilities engineering applications program (FEAP) demonstration, FY89," Technical Report GL-91-1, U.S. Army Engineer Waterways Experiment Station, Vicksburg, MS.

_____. (1991b). "Concrete block pavement for airfields," Technical Report GL-91-12, U.S. Army Engineer Waterways Experiment Station, Vicksburg, MS.

Atchley, T. L. (1989). "Innovative products and procedures used on Chouteau Island levee relocation," *The REMR Bulletin*, 6(3), U.S. Army Engineer Waterways Experiment Station, Vicksburg, MS.

Barfoot, J. (1987). "Careful design of Wallasey sea defence structure," *Concrete* 21(9), 47-50.

_____. (1988). "Newbiggin sea defence will bring local 'peace of mind'," *Concrete* 22(6), 15-19.

Barnaby, D. (1993). "Polymer concrete ... ideal for rehabilitating the infrastructure," *CI on Composites*, SPI Composites Institute, 2-3.

Barnaby, D., and Dikeou, J. T. (1984). "Applications of permanent precast polymer concrete forms for concrete rehabilitation," *International Symposium on Mechanical Properties of Special Concrete*, Transportation Research Record 1003, Transportation Research Board, National Research Council, Washington, DC.

- Beachcone Research, Inc. (1992). "Beachcones: preserving our valuable shorelines," New Orleans, LA.
- Berner, D. E., and Ghio, V. A. (1994). "Construction study for the Olmsted Dam, Ohio River," *News*, Ben C. Gerwick, Inc., San Francisco, CA.
- Beyke, D. E. (1991). "Mill Creek Ohio LFPP-Section 1, post-and-panel wall with anchors--lessons learned," *Proceedings of Corps of Engineers' Structural Engineering Conference*, Louisville, KY.
- Blaha, B. (1993). "Mississippi mighty," *Concrete Products* 96(1), 24-27.
- Canadian Specification Association. (1989). "Precast concrete pavers," Designation CAN3-A231.2-M85.
- Carver, R. D., Dubose, W. G., Heggins, J. M., and Wright, B. J. (1993). "Revetment stability tests for Sargent Beach, Texas," Technical Report CERC-93-14, U.S. Army Engineer Waterways Experiment Station, Vicksburg, MS.
- Clopper, P. E., and Chen, Y.-H. (1988). "Minimizing embankment damage during overtopping," FHWA-RD-88-181, Federal Highway Administration, McLean, VA.
- _____. (1991). "Protecting embankment dams with concrete block systems," *Hydro Review* 10(2), 54-67.
- Conboy, D. W. (1989). "Precast deck panels debut in Maine project," *Roads and Bridges*, 84-85.
- Concrete*. (1993). "West retaining wall, Pen-y-Clip Tunnel, Gwynedd, North Wales," 15-18.
- Concrete Construction*. (1992). "St. Hubert Tunnel."
- Concrete Products*. (1993). "Precast breakwater system protects shoreline," 96(6), 14.
- Construction News*. (1990). "Reinforced concrete block speeds job along," 57(16), 63.
- Davidson, D. D. (1974). "STA-POD stability tests," Miscellaneous Paper H-74-7, U.S. Army Engineer Waterways Experiment Station, Vicksburg, MS.
- Davis, R. E., Jansen, C., and Neelands, W. T. (1948a). "Grouted gravel fill and precast slabs provide new face for Barker Dam," *Civil Engineering*.

- Davis, R. E., Jansen, C., and Neelands, W. T. (1948b). "Restoration of Barker Dam," *Journal of the American Concrete Institute* 19(8), 633-667.
- Department of the Army, Corps of Engineers, Galveston District. (1991). (Draft). "Sargent Beach, Texas: Feasibility report and draft environmental impact statement," Gulf Intracoastal Waterway (Section 216 Study), Galveston, TX.
- The Dock and Harbour Authority*. (1990). "Marine engineering: the artificial reef project: Poole Bay," 71(818), 30-31.
- _____. (1991). "New quayside wall along River Tawe," 72(829), Foxlow Publications Ltd., London, 69.
- Duster, C. O. (1984). "Dam crest raising with reinforced earth retaining walls," Fourth Annual USCOLD Lecture, Phoenix, AZ.
- Edwards, A., and Clark, S. (1992). "Rehabilitation of coral reef flats using precast concrete," *The Concrete Society Journal*, England 26(1), 16-19.
- Engineer Update*. (1988). "Man vs nature," 12(3), 5.
- _____. 1990. "1989 design and environmental awards," 14(2), 5-6.
- Firth, D. (1994). "Precast concrete flume," *News*, Ben C. Gerwick, Inc., San Francisco, CA.
- The Fort Miller Company. (1989). "Ulsterville Bridge," Schuylerville, NY.
- Ganaden, M. E. (1991). "Structures in the Blue River Channel, Kansas City, Missouri," *Corps of Engineers' Structural Engineering Conference*, 1-11.
- Gehring, Don. (1991). "Conveyor system speeds RCC dam construction," *Concrete Construction* 36(11), 831-833.
- Grad, P. (1992). "Sydney drainage poses engineering challenge," *Engineers Australia* 64(4), 40-41.
- Gunnels, J. (1991). "Precast seal beam for railroad closures," *Corps of Engineers' Structural Engineering Conference*, 1-91.
- Guzaltan, F. (1992). "Precast concrete noise barrier walls for New Jersey Interstate Route 80," *PCI Journal* 37(4), 56-63.
- Hacker, K. (1986). "Precast panels speed rehabilitation of Placer Creek Channel," *The REMR Bulletin* 3(3), U.S. Army Engineer Waterways Experiment Station, Vicksburg, MS.
- Hagen, R. (1992). "Precast box beats bad weather," *Concrete Pipe News*, 5.

- Halmos, E. E. (1984). "Precast deck sections achieve overnight success on Potomac River Bridge," *Concrete Products* 87(4), 24-26.
- Hansen, K. D., and Reinhardt, W. G. (1991). "Roller-compacted concrete dams," McGraw-Hill, Inc., New York.
- Harris, B. N., Palma, J. F., and Miller, D. F. (1991). "Underwater repair of concrete based on REMR technical information," *The REMR Bulletin* 8(4), U.S. Army Engineer Waterways Experiment Station, Vicksburg, MS.
- Headquarters, U.S. Army Corps of Engineers. (1992). "Roller-compacted concrete," EM 1110-2-2006, Washington, DC.
- Hewlett, H. W. M., Boorman, L. A., and Bramley, M. E. (1987). "Design of reinforced grass waterways," Report 116, Construction Industry Research and Information Association, London, England.
- Highway & Heavy Construction*. (1985). "Membrane-lined panels face new RCC dam," 128(2), 64-65.
- _____. (1988). "Bridges and structures: girder-mounted crane cuts guidewall costs," 131(1), 52-55.
- Himsley, N. (1991). "Recent dam rehabilitation projects in New South Wales, Australia," *1991 Annual Conference Proceedings*, Association of State Dam Safety Officials, Lexington, KY, 193-198.
- Hurd, M. K. (1988). "Structural rehabilitation of concrete lighthouse," *Concrete Construction* 33(7), 659-662.
- _____. (1990). "Short-span arch bridges," *Concrete Construction* 35(7), 624-631.
- Hyma, W. R. (1979). "Replacing timber decks on railroad bridges with prestressed concrete slabs," *Concrete International* 1(5), 18-21.
- Jaeger, J. J. (1986). "Lock & Dam 26R: A value engineered guidewall," Directorate of Engineering and Construction, Washington, DC, 581.
- King, P. M. and Smith, D. R. (1991). "Interlocking concrete airfield pavements," *Concrete International* 13(12), 24.
- Klemens, T. L. (1991). "Strengthening an old dam with 180 facelifts," *Highway & Heavy Construction* 134(9), 24-27.
- Kraai, P. T. (1989). "Nichols & McClure spillway renovation," Association of State Dam Safety Officials, Lexington, KY.
- Mainar, J. and Arenas, J. J. (1986). "Renovation of the historic Maria Cristina Bridge," *PCI Journal* 31(2), 20-29.

- Marianos, W. N., Jr. (1991). "Railroad use of precast concrete bridge structures," *Concrete International* 13(9), 30-35.
- Markle, D. G., and Davidson, D. D. (1984). "Breakage of concrete armor units; survey of existing Corps structures," Miscellaneous Paper CERC-84-2, U.S. Army Engineer Waterways Experiment Station, Vicksburg, MS.
- Melby, J. A., and Turk, G. F. (1994). "CORE-LOG concrete armor unit design," Coastal Engineering Technical Note, CETN III-53, U.S. Army Engineer Waterways Experiment Station, Vicksburg, MS.
- McClellan, B. K. (1985). "Post-and-panel-type retaining wall," *Completion report on the Corps of Engineers Structural Engineering Conference*, Portland, OR.
- McDonald, J. E. (1987a). "Precast concrete stay-in-place forming system for lock wall rehabilitation," *The REMR Bulletin* 4(1), U.S. Army Engineer Waterways Experiment Station, Vicksburg, MS.
- _____. (1987b). "Rehabilitation of navigation lock walls: case histories," Technical Report REMR-CS-13, U.S. Army Engineer Waterways Experiment Station, Vicksburg, MS.
- _____. (1990). "Anchor embedment in hardened concrete under submerged conditions," Technical Report REMR-CS-33, U.S. Army Engineer Waterways Experiment Station, Vicksburg, MS.
- Miles, W. R. (1993). "Comparison of cast-in-place concrete versus precast concrete stay-in-place forming systems for lock wall rehabilitation," Technical Report REMR-CS-41, U.S. Army Engineer Waterways Experiment Station, Vicksburg, MS.
- Mitscher, K. A. (1991). "Sheet-pile and precast concrete U-flume low-flow channels for the Blue River Paved Reach Project," *Corps of Engineers' Structural Engineering Conference*, 1-10.
- Moler, W. A., and Moore, J. F. (1988). "Design of seepage control systems for RCC dams," *Roller Compacted Concrete II*, 61-75, American Society of Civil Engineers, New York.
- Monti, R. M., and Eglot, J. M. (1986). "Tunnel ceiling replaced over traffic," *Civil Engineering* 56(6), 80-83.
- Munn, W. D. (1987). "Precast cofferdams speed pier construction," *Highway & Heavy Construction* 1(10), 58-60.
- National Precast Concrete Association Australia. (1991). "Turning back the tide," *National Precaster*, 3.

- Newell, R. J. (1931). "Deadwood Dam, Boise Project, Idaho," *New Reclamation Era Magazine*, Bureau of Reclamation, Denver, CO.
- New Zealand Concrete Construction*. (1991). "Clyde Quay Breakwater refurbishment," 35(9), 13-16.
- _____. (1993-1994). "Chaffers Marina breakwater," 21-22.
- _____. (1994). "Salmon thrive in concrete," 38(1), 30.
- Pace, C. E. (1978). "Engineering condition survey and evaluation of Troy Lock and Dam, Hudson River, New York, Report 1, Engineering Condition Survey," Miscellaneous Paper C-78-6, U.S. Army Engineer Waterways Experiment Station, Vicksburg, MS.
- Pace, C. E., Campbell, R., and Wong, S. (1981). "Engineering condition survey and evaluation of Troy Lock and Dam, Hudson River, New York, Report 2, evaluation and rehabilitation," Miscellaneous Paper C-78-6, U.S. Army Engineer Waterways Experiment Station, Vicksburg, MS.
- Paul, M. J. (1987). "Brandywine Shoal Lighthouse," *Concrete International*, American Concrete Institute 9(6), 46-53.
- Pope, T. B. (1991). "Precast box culverts provide quick long-lasting repair," *Concrete Pipe News*, 5.
- Precast Concrete Institution. (1982). "Restoration of the Jediah Hill Covered Bridge," *PCI Journal* 27(5), 131-135.
- _____. (1985). "Replacement of coal storage retaining walls," *PCI Journal* 30(5), 162-167.
- _____. (1988). "Dublin Scioto Bridge," *PCI Journal* 33(3), 148-153.
- Public Works*. (1991). "New breakwater technology," 122(2), 53-54.
- _____. (1993). "Concrete pipe rehabilitates culverts," 12(8), 78.
- Radley, R. J. (1990). "Comparative study for concrete rehabilitation methods: cast-in-place versus precast panels," Bergman Associates, Rochester, NY.
- Randall, F.A., Jr. (1989). "Retaining wall system offers economy, speed of construction," *Concrete Construction* 34(4), 398-399.
- Reeves, G., and Yates, L. (1985). "Simplified design and construction control for roller compacted concrete," *Roller Compacted Concrete*, American Society of Civil Engineers, New York, 48-61.
- Roads & Bridges*. (1985). "Replacing rural bridges," 23(11), 51-55.

- Rogers, R., and Ruggeri, A. H. (1992). "Fellows Lake spillway modifications," *1992 Annual Conference Proceedings*, American Society of Dam Safety Officials, Baltimore, MD.
- Ross, R. R. (1991). "Channel wall study for the River Des Peres Flood Control Project," *Proceedings of the Corps of Engineers Structural Engineering Conference*, 1-15.
- Rural and Urban Roads*. (1983). "Turnpike re-decks two spans in quarter-sections over four construction seasons," 29-30.
- Schrader, E. K. (1985). "Watertightness and seepage control in roller compacted concrete dams," *Roller Compacted Concrete*, American Society of Civil Engineers, New York.
- Slavid, R. (1991). "Hard line yields to softer approach," *Construction Weekly* 3(15), 14-15.
- Slavis, Charles. (1983). "Precast concrete deck modules for bridge deck reconstruction," *PCI Journal* 28(5), 120-135.
- _____. (1985). "Bridge redecking with precast components," *Better Roads* 55(5), 22.
- Smith, D. R. (1993). "Interlocking concrete pavements: performing in North America," *Public Works* 124(8), 60-61.
- Smyers, W. L. (1984). "Rehabilitation of the Freemont Street Bridge," *PCI Journal* 29(5), 34-51.
- Soast, Allen. (1993 May). "Columbia congestion relieved," *Engineering News Record*, 22-24.
- Sumner, A. C. (1993). "Rehabilitation of Crescent and Vischer Ferry Dams, construction techniques & problem solutions," *Geotechnical Practice in Dam Rehabilitation*, American Society of Civil Engineers, New York.
- Sumner, A. C., Nash, M. F., and Haag, T. W. (1991). "Rehabilitation of the dams at the Crescent and Vischer Ferry Hydroelectric Projects," *Waterpower '91, Proceedings of the International Conference on Hydro-power* 3, 1485-1494.
- Stowe, R. L., Ragan, S. A., Campbell, R. L., Pavlov, B. A., Thornton, H. T., Jr., and Wong, G. S. (1980). "Concrete and rock tests, major rehabilitation and compliance, Lockport Lock, Illinois Waterway, Chicago District," Miscellaneous Paper SL-80-4, U.S. Army Engineer Waterways Experiment Station, Vicksburg, MS.

- Turner, H. O., Jr., and Pickering, G. A. (1979). "Kissimmee River structures, Central and Southern Florida Flood Control Project; hydraulic model investigation," Technical Report HL-79-4, U.S. Army Engineer Waterways Experiment Station, Vicksburg, MS.
- Ulyatt, N. B., and Winch, G. W. (1992). "Precast concrete noise barrier commemorates historic Selkirk Settlement," *PCI Journal* 36(4), 48-55.
- Vitale, J., and Siebold, M. (1992). "Precast construction keeps culvert on track," *Roads & Bridges*, 38.
- Vorobieff, G. (1991). "Concrete acoustic barriers for roadways," *Constructional Review* 64(3), 56-59.
- Wong, N. C., Feldsher, T. B., Wright, R. S., and Johnson, D. H. (1992). "Final design and construction of Gibraltar Dam strengthening," *Roller Compacted Concrete III*, American Society of Civil Engineers, New York.
- Wooten, R. Lee, Welsh, R., Wirkus, K. E., and Whiteside, S. L. (1993). "Construction of CCM overtopping protection on three parkway dams," *Geotechnical Practice in Dams Rehabilitation*, American Society of Civil Engineers, New York.
- Zimmerman, A. (1987). "Seawall creates Cleveland lagoon," *ENR* 219(16), 24.

REPORT DOCUMENTATION PAGE

Form Approved
OMB No. 0704-0188

Public reporting burden for this collection of information is estimated to average 1 hour per response, including the time for reviewing instructions, searching existing data sources, gathering and maintaining the data needed, and completing and reviewing the collection of information. Send comments regarding this burden estimate or any other aspect of this collection of information, including suggestions for reducing this burden, to Washington Headquarters Services, Directorate for Information Operations and Reports, 1215 Jefferson Davis Highway, Suite 1204, Arlington, VA 22202-4302, and to the Office of Management and Budget, Paperwork Reduction Project (0704-0188), Washington, DC 20503.

1. AGENCY USE ONLY (Leave blank)		2. REPORT DATE June 1995	3. REPORT TYPE AND DATES COVERED Final report	
4. TITLE AND SUBTITLE Applications of Precast Concrete in Repair and Replacement of Civil Works Structures			5. FUNDING NUMBERS	
6. AUTHOR(S) James E. McDonald, Nancy F. Curtis				
7. PERFORMING ORGANIZATION NAME(S) AND ADDRESS(ES) U.S. Army Engineer Waterways Experiment Station Structures Laboratory 3909 Halls Ferry Road Vicksburg, MS 39180-6199			8. PERFORMING ORGANIZATION REPORT NUMBER Technical Report REMR-CS-49	
9. SPONSORING/MONITORING AGENCY NAME(S) AND ADDRESS(ES) U.S. Army Corps of Engineers Washington, DC 20314-1000			10. SPONSORING/MONITORING AGENCY REPORT NUMBER	
11. SUPPLEMENTARY NOTES Available from National Technical Information Service, 5285 Port Royal Road, Springfield, VA 22161.				
12a. DISTRIBUTION/AVAILABILITY STATEMENT Approved for public release; distribution is unlimited.			12b. DISTRIBUTION CODE	
13. ABSTRACT (Maximum 200 words) The objective of this study was to develop, review, and analyze selected case histories involving applications of precast concrete in the repair or replacement of civil works structures. Information was obtained through literature searches; discussions with designers, precasters, and contractors; visits to project sites; and discussions with project personnel. Each case history includes a description of the project, the cause and extent of the deficiency that necessitated repair or replacement, design details, descriptions of materials and precasting procedures, construction techniques, costs, and performance to date of the precast concrete. Based on a review and analysis of these case histories, recommendations for future applications of precast concrete were developed, and areas that could benefit from research were identified.				
14. SUBJECT TERMS See attached.			15. NUMBER OF PAGES 298	
			16. PRICE CODE	
17. SECURITY CLASSIFICATION OF REPORT UNCLASSIFIED	18. SECURITY CLASSIFICATION OF THIS PAGE UNCLASSIFIED	19. SECURITY CLASSIFICATION OF ABSTRACT UNCLASSIFIED	20. LIMITATION OF ABSTRACT	

14. SUBJECT TERMS

Bridges

Channels

Coastal structures

Culverts

Dams

Floodwalls

Levees

Navigation locks

Offshore structures

Precast concrete

Repair

Tunnels