



US Army Corps
of Engineers
Construction Engineering
Research Laboratories

USACERL Technical Report CRC-94/02
February 1994

Layaway Procedures for U.S. Army Historic Facilities: Testing of Computerized Inspection, Maintenance, and Repair Guidelines

by
Samuel L. Hunter

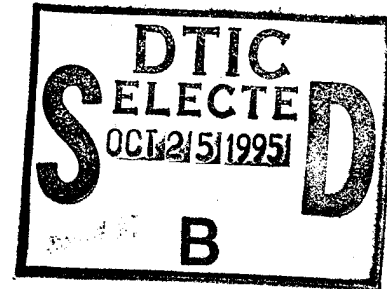

The U.S. Army has thousands of buildings that are either historic or potentially historic. Many of these buildings are at installations that will close or be reduced in size, and the Army will need to lay away the buildings. The Army must comply with many laws about the treatment and maintenance and repair of historic buildings when laying away these buildings.

This report discusses the computerization of guidelines developed in two previous USACERL reports on layaway procedures. These inspection guidelines require inspectors to use many pages of forms, resulting in stacks of paper that must be transcribed at the office

and reproduced in a useable report format. Computerization of the guidelines makes layaway inspection much easier and less confusing.

USACERL conducted field tests of the computer software at Fort Sheridan, IL and Fort Ord, CA. The minimum requirement for running the software is a 386/20 MHz IBM-compatible laptop without a math co-processor. Although the battery for the penbased laptop computer used during field inspection only lasted 1-½ to 2 hours, inspectors found the computerized guidelines much easier to use than the manual versions of the layaway reports.

19951024 110

DTIC QUALITY INSPECTED 5

The contents of this report are not to be used for advertising, publication, or promotional purposes. Citation of trade names does not constitute an official endorsement or approval of the use of such commercial products. The findings of this report are not to be construed as an official Department of the Army position, unless so designated by other authorized documents.

Accession For	
NTIS GRA&I	<input checked="" type="checkbox"/>
DTIC TAB	<input type="checkbox"/>
Unannounced	<input type="checkbox"/>
Justification	
By	
Distribution/	
Availability Codes	
Dist	Avail and/or Special
A-1	

DESTROY THIS REPORT WHEN IT IS NO LONGER NEEDED

DO NOT RETURN IT TO THE ORIGINATOR

USER EVALUATION OF REPORT

REFERENCE: USACERL Technical Report CRC-94/02, *Layaway Procedures for U.S. Army Historic Facilities: Testing of Computerized Inspection, Maintenance, and Repair Guidelines*

Please take a few minutes to answer the questions below, tear out this sheet, and return it to USACERL. As user of this report, your customer comments will provide USACERL with information essential for improving future reports.

1. Does this report satisfy a need? (Comment on purpose, related project, or other area of interest for which report will be used.)

2. How, specifically, is the report being used? (Information source, design data or procedure, management procedure, source of ideas, etc.)

3. Has the information in this report led to any quantitative savings as far as manhours/contract dollars saved, operating costs avoided, efficiencies achieved, etc.? If so, please elaborate.

4. What is your evaluation of this report in the following areas?

a. Presentation: _____

b. Completeness: _____

c. Easy to Understand: _____

d. Easy to Implement: _____

e. Adequate Reference Material: _____

f. Relates to Area of Interest: _____

g. Did the report meet your expectations? _____

h. Does the report raise unanswered questions? _____

i. General Comments. (Indicate what you think should be changed to make this report and future reports of this type more responsive to your needs, more usable, improve readability, etc.)

5. If you would like to be contacted by the personnel who prepared this report to raise specific questions or discuss the topic, please fill in the following information.

Name: _____

Telephone Number: _____

Organization Address: _____

6. Please mail the completed form to:

Department of the Army
CONSTRUCTION ENGINEERING RESEARCH LABORATORIES
ATTN: CECER-TR-I
P.O. Box 9005
Champaign, IL 61826-9005

REPORT DOCUMENTATION PAGE

Form Approved
OMB No. 0704-0188

Public reporting burden for this collection of information is estimated to average 1 hour per response, including the time for reviewing instructions, searching existing data sources, gathering and maintaining the data needed, and completing and reviewing the collection of information. Send comments regarding this burden estimate or any other aspect of this collection of information, including suggestions for reducing this burden, to Washington Headquarters Services, Directorate for Information Operations and Reports, 1215 Jefferson Davis Highway, Suite 1204, Arlington, VA 22202-4302, and to the Office of Management and Budget, Paperwork Reduction Project (0704-0188), Washington, DC 20503.

1. AGENCY USE ONLY (Leave Blank)	2. REPORT DATE February 1994	3. REPORT TYPE AND DATES COVERED Final		
4. TITLE AND SUBTITLE Layaway Procedures for U.S. Army Historic Facilities: Testing of Computerized Inspection, Maintenance, and Repair Guidelines		5. FUNDING NUMBERS MIPR E87920573 dated September 1992		
6. AUTHOR(S) Samuel L. Hunter				
7. PERFORMING ORGANIZATION NAME(S) AND ADDRESS(ES) U.S. Army Construction Engineering Research Laboratories (USACERL) P.O. Box 9005 Champaign, IL 61826-9005		8. PERFORMING ORGANIZATION REPORT NUMBER TR CRC-94/02		
9. SPONSORING / MONITORING AGENCY NAME(S) AND ADDRESS(ES) U.S. Army Center for Public Works ATTN: DAIM-ED-N 7701 Telegraph Road Alexandria, VA 22310-3862		10. SPONSORING / MONITORING AGENCY REPORT NUMBER		
11. SUPPLEMENTARY NOTES Copies are available from the National Technical Information Service, 5285 Port Royal Road, Springfield, VA 22161.				
12a. DISTRIBUTION / AVAILABILITY STATEMENT Approved for public release; distribution is unlimited.		12b. DISTRIBUTION CODE		
13. ABSTRACT (Maximum 200 words) <p>The U.S. Army has thousands of buildings that are either historic or potentially historic. Many of these buildings are at installations that will close or be reduced in size, and the Army will need to lay away the buildings. Many laws about the treatment and maintenance and repair of historic buildings must be complied with when laying away these buildings.</p> <p>This report discusses the computerization of guidelines developed in two previous USACERL reports on layaway procedures. These inspection guidelines require inspectors to use many pages of forms, resulting in stacks of paper that must be transcribed at the office and reproduced in a useable report format. Computerization of the guidelines makes layaway inspection much easier and less confusing.</p> <p>Field tests of the computer software were conducted at Fort Sheridan, IL and Fort Ord, CA. The minimum requirement for running the software is a 386/20 Mhz IBM-compatible laptop without a math coprocessor. Although the battery for the penbased laptop computer used during field inspection only lasted 1-1/2 to 2 hours, inspectors found the computerized guidelines much easier to use than the manual versions of the layaway reports.</p>				
14. SUBJECT TERMS facility layaway historic buildings base closure		base realignment		15. NUMBER OF PAGES 90
				16. PRICE CODE
17. SECURITY CLASSIFICATION OF REPORT Unclassified	18. SECURITY CLASSIFICATION OF THIS PAGE Unclassified	19. SECURITY CLASSIFICATION OF ABSTRACT Unclassified	20. LIMITATION OF ABSTRACT SAR	

Foreword

This study was conducted for U.S. Army Center for Public Works (USACPW) under Military Interdepartmental Purchase Request (MIPR) E87920573 dated September 1992. The technical monitors were Dr. Connie Ramirez, DAIM-ED-N, and Maria Bourossa, CECPW-ES.

The work was performed by Engineering and Materials Division (FM), Infrastructure Laboratory (FL), U.S. Army Construction Engineering Research Laboratories (USACERL). The USACERL principal investigator was Samuel L. Hunter. Dr. Paul A. Howdyshell is Chief, CECER-FM and Dr. Michael J. O'Connor is Chief, CECER-FL. The USACERL technical editor was Linda L. Wheatley, Information Management Office.

The author gratefully acknowledges the contributions of Dr. Donald Uzarski, Ken Cobb, Jennifer Engelage, Jane DeRose, Thomas Eliason, Rob Wilson, and Chuck Whittleder, USACERL, for help in project research and manuscript preparation. The authors also acknowledge the support of Master Planners Ron Girty and George Arinous and LTC Rynearson, Director of Public Works (DPW) at Fort Sheridan, IL for coordinating field visits to the installation and providing valuable comments on the program and the previously developed guidelines. Further acknowledgement goes to Joni Gerry, Cultural Resources Officer, and Ron White, Deputy DPW of Fort Ord, CA for their efforts in coordinating field work and providing information on the Base Realignment and Closure (BRAC) process. Special thanks go to Keith Landreth and Joyce Baird, USACERL, for their efforts in fostering this project by coordinating information with the sponsors and allowing the author to participate in related research.

LTC David J. Rehbein is Commander, USACERL, and Dr. L.R. Shaffer is Director.



The Tri-Services Cultural Resources Research Center is a research and technical support center that assists the U.S. military services in the stewardship of cultural resources located within Department of Defense (DOD) installations or facilities. The Center, located at USACERL, helps installations manage their cultural resources and comply with Federal, State, and DOD preservation mandates.

Contents

SF 298	1
Foreword	2
List of Tables and Figures	5
1 Introduction	7
Background	7
Objectives	8
Approach	8
Scope	8
Mode of Technology Transfer	8
2 BRAC Process for Historic Buildings	10
Background	10
What Federal Guidelines Must Be Followed in Laying Away Historic Buildings? ..	10
What Is a Historic Building?	11
Why Are Historic Buildings Protected by the Federal Government?	12
Adverse Effects on Historic Buildings	12
Summary	13
3 Software Development	14
Introduction	14
Software Development Plan	14
4 Program Description	19
Introduction	19
Inventory Screens	20
Inspection	23
5 Testing at Fort Sheridan	27
Introduction	27
Exterior Closure System	27
Roofing System	28
Interior Construction System	29
Plumbing	31
HVAC System	31
Electrical System	32
Other Building Issues	32
Summary	33

6	Testing at Fort Ord	34
	Introduction	34
	Exterior Closure System	34
	Roofing System	35
	HVAC System	36
	Other Building Issues	37
	Program Issues	37
	Summary	37
7	Conclusions, Recommendations, and Final Observations	38
	Conclusions	38
	Recommendations	38
	Final Observations	39
	References	40
	Appendix A: Systems, Components, and Subcomponents	43
	Appendix B: Software Data Flow Diagrams	47
	Appendix C: Reports of Buildings at Fort Sheridan	53
	Appendix D: Reports of Buildings at Fort Ord	64
	Appendix E: Program Database Characteristics	84
	Acronyms	87
	Distribution	

List of Tables and Figures

Tables

1	Software development methodology	15
D1	Surveyed buildings at Fort Ord	64

Figures

1	First screen of layaway program	19
2	Building information screen	20
3	Building location screen	21
4	Additional building information screen	22
5	Final building information screen	22
6	System selection screen	23
7	Component selection screen	24
8	Subcomponent selection screen	24
9	Distress selection screen	25
10	Report selection screen	26
B1	General flow of the layaway program	47
B2	Flow of layaway program at inspection level	48
B3	Flow of layaway program to inspect a building	49
B4	Flow of layaway program to inspect	50
B5	Flow of layaway program to generate a report	51

B6	General data structure	52
B7	General building data structure	52

1 Introduction

Background

The U.S. Army has thousands of buildings that are either historic or potentially historic. Many of these buildings are at installations that Base Realignment and Closure (BRAC) Committee actions will close or reduce in size (DOD 1988, 1991, and 1993). The intent of the BRAC committee is to dispose of or transfer the property as quickly as possible. Because the time between vacancy and transfer or disposal may be lengthy, the Army will need to layaway many historic buildings.

Uzarski et al. (1991, volumes I and II) and Hunter et al. (1992) addressed layaway of facilities, including deactivation, periodic maintenance and repair (M&R), and reactivation. USACERL developed these reports because existing regulations (i.e., Army Regulation [AR] 210-17, January 1967; AR 420-10, 3 August 1989; and Technical Note [TN] 420-10-08, 1 October 1992) were not comprehensive enough to provide technical guidance on facility layaway.

Installations cannot take the layaway of historic buildings lightly. The Army must comply with many laws about the treatment and maintenance and repair (M&R) of historic buildings [36 CFR 800, January 1991; National Historic Preservation Act of 1966 [NHPA], as amended] when laying away historic buildings. Layaway of historic buildings often involves unusual and delicate materials that need special attention. The developed inspection and M&R procedures discussed in Uzarski et al. (1991) and Hunter et al. (1992) required inspectors to use separate forms for each component or site inspected, resulting in stacks of paper that must be transcribed in an office at the installation and reproduced in a useable report format. The U.S. Army Center for Public Works (USACPW) tasked the U.S. Army Construction Engineering Research Laboratories (USACERL) with computerizing the developed procedures for easier use and field testing the program at Fort Sheridan, IL and Fort Ord, CA. USACPW selected these sites for their different climates and locations. Running the software requires a minimum of a 386/20 Mhz IBM-compatible laptop without a math coprocessor.

Objectives

The objectives of this study were to computerize the developed procedural guidelines for layaway of historic buildings and field test the program.

Approach

The work started with computerizing the inspection and M&R guidelines found in Volume II of Uzarski et al. (1991) and Hunter et al. (1992). USACERL planned to put these guidelines in a software program to run on a penbased laptop computer easily used in the field to record the data and generate the report. Since programming this type of computer is a new field, USACERL contracted Tanner and Associates, Inc. of Champaign, IL, and Advanced Information Services, Inc., (AIS) of Peoria, IL, to complete the programming. USACERL field tested the developed program at Forts Sheridan and Ord.

Scope

This report addresses the results from field tests of the developed software program that covered the previously developed procedures for the layaway of historic buildings. These procedures include tasks associated with deactivation, periodic M&R, and reactivation of a variety of historic building systems.

This report also covers inspection personnel observations at the test sites, including security, ventilation, and the "do-nothing" management style of laid away buildings (Uzarski et al. 1991).

The scope of this report does not include layaway and repair cost estimating, life-cycle cost analyses of layaway procedures, determining the best level of M&R during layaway, or testing layaway procedures on nonhistoric facilities.

Mode of Technology Transfer

This report supports completed work (Uzarski et al. 1991; Hunter 1992) on the layaway of buildings. The computerized guidelines are available from USACERL (CECER-FMM) and are for Directorate of Public Works (DPW) personnel at installations affected by base closure. Personnel can use the program to prepare a layaway M&R program for historic buildings or do the actual layaway. Accordingly, any installation or Major Army Command (MACOM) contemplating historic building

layaway should have the computerized guidelines. Installation personnel should use this program as a starting point for the layaway of buildings because many of the outlined procedures have not been field tested. Computer disks may be obtained by calling CECER-FMM at (217) 398-5217.

Once the previously developed guidelines have been modified with the computerized findings discussed in this report and any additional research, the layaway guidelines for U.S. Army historic and nonhistoric facilities should be issued in a Department of the Army Technical Manual or Pamphlet.

2 BRAC Process for Historic Buildings

Background

Army installations must follow several regulations during the historical layaway process. Failure to follow regulations may result in litigation. This chapter is a brief review of Hunter et al. (1992), Chapter 2, covering pertinent Federal regulations and the purpose of historical building layaway.

What Federal Guidelines Must Be Followed in Laying Away Historic Buildings?

Protection of historic buildings falls under the NHPA, as amended. Two essential parts of the NHPA are Sections 106 and 110, which are briefly reviewed as follows:

Section 106

The Section 106 review process has five steps to identify and protect historic buildings (Advisory Council of Historic Preservation, October 1986).

- Step 1. **Identify and Evaluate Historic Properties:** Once the Army has located and evaluated historic properties on the installation, then it must establish that a proposed action is an "undertaking" on those buildings (i.e., layaway).
- Step 2. **Assess Effects:** The Army must consult with the SHPO* to decide whether the proposed "undertaking" could affect the historic properties.
- Step 3. **Consultation:** If the SHPO decides that the Army's proposed undertaking adversely affects the historic buildings, the Army must begin consultation to consider ways to avoid, reduce, or mitigate the adverse effects of the undertaking (i.e., layaway). At the very minimum, consultation takes place

* SHPO - State Historical Preservation Officer: Appointed by the governor of each state or territory, the SHPO consults with Federal agencies during Section 106 review. The SHPO administers the National Historical Preservation Program at the state level, reviews National Register nominations, and maintains file data on historic properties that have been identified but have not been nominated.

between the Army and the SHPO. The Advisory Council* also may become involved. The SHPO or the Army can request that the Advisory Council become involved, or it may involve itself without an invitation. The Army, the SHPO, or the Council also may consult other interested parties.

The agreement between these parties on ways to accommodate historic preservation needs results in a Memorandum of Agreement (MOA). The MOA contains specifications about how the Army will carry out the undertaking to avoid or mitigate adverse effects on the historic character of the building.

Step 4. Council Comment: If the Advisory Council is a consulting party on the development of the MOA, the execution of the MOA serves as the Council's comment on the undertaking. If the Advisory Council is not a consulting party of the MOA, then they must review and accept the terms of the MOA.

Step 5. Proceed: If the Advisory Council does not agree with the MOA, then the Army must consider the Council's written comments. The Army can then decide how to proceed with the undertaking, and it does not necessarily have to follow the Council's advice. Before the Army goes on with the undertaking, it should tell the Advisory Council of its decision.

Section 110 Requirements

Under Section 110, the Army must:

1. Carry out their programs according to National Historic Preservation Act policy.
2. Appoint historic preservation officers to coordinate the agency's (i.e., installation's) activities under the Act.
3. Identify and preserve historic properties under their ownership or control.
4. Make efforts to lessen harm to National Historic Landmarks and historic properties.

* The Advisory Council on Historic Preservation is an independent Federal agency charged with advising the President and the Congress on historic preservation matters and administering the provisions of Section 106 of the National Historic Preservation Act (NHPA).

What Is a Historic Building?

The preservation of historic buildings is necessary to help remind us of our past. A historic building can be significant for many reasons, as follows:

- the buildings have made an impact on architecture, archeology, engineering, culture, or military history
- events that have made a significant contribution to the broad patterns of our history can make buildings historic
- buildings associated with the lives of significant persons in U.S. history
- a building embodies the distinctive characteristics of a type, time period, or method of construction
- a building represents the work of a master, has high artistic value, or represents a significant and distinguishable entity whose components may lack individual distinction
- buildings have yielded information important in prehistory or history.

Many steps determine if a building is historic. A “rule of thumb” sometimes used to determine if it is historic is if the building is 50 or more years old. Buildings less than 50 years old also may be historic because of exceptional historical or architectural significance. Installations should evaluate significant buildings according to the Section 106 review process before proceeding with any historic undertakings.

Why Are Historic Buildings Protected by the Federal Government?

Historic military properties are important for studying our military history and preserving our heritage. Historic military properties are especially significant because of:

- their association with prominent political and military figures over the years
- the important role that military installations have played in preserving the safety and security of our nation.

It is the statutory responsibility of the Army to follow the NHPA. In essence, this means that Army installations must follow a five-step process explained in this chapter (p 10). Failure to follow this process may result in litigation.

Adverse Effects on Historic Buildings

Many people on Army installations think that layaway of historic buildings means to lock the door and walk away. However, according to 36 CFR 800.9(b), "Criteria of Adverse Effect":

An undertaking is considered to have an adverse effect when the effect on a historic property may diminish the integrity of the property's location, design, setting, materials, workmanship, feeling, or association: Adverse effects include ... Neglect of a property resulting in its deterioration or destruction (ex: failure to maintain, repair, or periodically inspect a historic building due to lack of funds or personnel)
...

This means that locking the door and walking away from a laid away building violates regulations. An installation **MUST** maintain a historic building in its laid away state until disposal.

Summary

While this chapter has briefly addressed the procedures of laying away historic buildings, the Army must be aware that it must be sensitive to the needs of historic properties *during and after the layaway process*. Installations must maintain and protect laid away historic properties, must not allow deterioration due to neglect of historical elements of the laid away building, and must not allow anything to compromise the historic integrity of the building. Failure to do so may result in litigation. A more detailed discussion of the BRAC process is contained in Hunter et al. (1992), Chapter 2.

3 Software Development

Introduction

The procedural guidelines described in Volume II of Uzarski et al. (1991) and Hunter et al. (1992) are difficult for everyday manual use in the field. The guidelines are more practical if they are computerized for use on a penbased laptop computer. This chapter discusses the process used to computerize the guidelines.

Software Development Plan

The process of translating the guidelines into computer code entailed a structured approach to software development rather than simply pasting together a program. The software developmental plan used by USACERL followed the classic "waterfall" model (Pressman 1992) of computer software development. As shown in Table 1, the development followed a series of defined steps, each leading to a more refined product. All the tasks in each step were completed through a joint effort between USACERL, Tanner and Associates, and AIS. A description of the fulfillment of the first step and tasks follows Table 1. Other steps and tasks are mentioned only briefly to show the process USACERL followed to develop the program.

Requirements Specification

Purpose/Objective. The purpose of this software program was to computerize the layaway M&R guidelines as outlined in Volume II of Uzarski et al. (1991) and Hunter et al. (1992).

Functional Requirements. The only functional requirement for the program was to operate it on a penbased laptop computer, GRIDPAD® 386 SL, made by GRID Systems Corporation of Flushing, NY.* USACERL found out later that the program also would work on a 386 or 486 personal desktop computer and a NEC VERSA laptop computer.**

* GRID Systems no longer manufactures the GRIDPAD® 386 SL as it has been upgraded.

** NEC Ultralight VERSA 25C, 25 MHz, 486, with 4 MB RAM manufactured by NEC Technologies, 12450 Fairlakes Circle, Fairfax, VA.

Table 1. Software development methodology.

Requirements Specification	<ul style="list-style-type: none"> · Purpose/Objective · Functional Requirements · Data Requirements · Context Level Diagrams · System Requirements · Hardware/Software Platform · Operating/Keyboard Standards
Functional Definition	<ul style="list-style-type: none"> · Test Bed · Data Flow Diagrams · Process Descriptions · Data Dictionary · Performance Criteria · Acceptance Criteria · System Test Plan · Boundary Conditions
System Design	<ul style="list-style-type: none"> · Structure Charts · Pseudo Code · Database Schema · Final Prototype · Test Data · Code/Testing Plan (Top-down) · Problem Management/Resolution Plan
Coding/Testing	<ul style="list-style-type: none"> · Actual System · White Box Testing Results · Functional Validation Results · Stress Test Results · Final User Documentation · Version Control Plan · Detailed Acceptance/Implementation Plan
Implementation	<ul style="list-style-type: none"> · Testing Results · Production/Distribution/T² Plan · Software Support · Enhancement Plan

Data Requirements. The program data requirements identified by USACERL and AIS included required fields, field lengths, and characteristics. The fields required to be entered by the user include building identification, name, and location, POC name and phone, architect, drawing number and location, historic description, architectural style, building type, category code, description, and building use. Each of these fields was given a length and characteristic (i.e., alphanumeric or integer). The user also selects several fields such as: system, component (shown in Appendix A), distress, and quantity of distress (as outlined in Hunter et al. [1992]). These fields also were given lengths and characteristics.

Context Level Diagrams. USACERL and AIS developed the preliminary context level diagrams (flowcharts) showing functional breakdown and data flows (shown in Appendix B).

System Requirements. The only system requirement is to run the software on a laptop 386/20 Mhz machine without a math coprocessor. USACERL found that the program runs much faster on a desktop 386 or 486 personal computer.

Hardware/Software Platform. An IBM AT-compatible 386/20 is the minimum hardware platform required for running the application. USACERL and AIS chose the development software program of Power PEN PAL™* because it had built-in pen drivers required by GRIDPAD®. USACERL and AIS also chose dBASE III** as the database manager.

Operating/Keyboard Standards. The program runs under Microsoft DOS*** and follows Power PEN PAL™ keyboard standards. However, when running the program on a desktop personal computer, the mouse functions the same as the pen.

Functional Definition

After completing the earlier steps, USACERL and AIS further defined the parts of the software program as follows:

Test Bed. Instead of a separate test bed for this program, the test bed would be the GRIDPAD® mentioned earlier.

Data Flow Diagrams. USACERL and AIS further defined and sketched the data flow diagrams (flowcharts) from the previous step.

Process Descriptions. USACERL and AIS developed a process description for the software program.

Data Dictionary. AIS further defined and completed the data dictionary to show the different data fields, characteristics, and field lengths required for the program (Appendix E).

Performance Criteria. USACERL set up performance and acceptance criteria for the software program.

System Test Plan. A simple system test plan was developed to test the program several times to ensure that all the data flowed correctly.

* Made by Pen Pal Associates, Inc. of Los Altos, CA.

** Made by Ashton-Tate Corporation, Torrance, CA.

*** Disk operating system.

Boundary Conditions. USACERL defined the boundary conditions of the program as those guidelines set up in Volume II of Uzarski et al. (1991) and Hunter et al. (1992). USACERL also decided that if any conditions not in the previous guidelines were encountered, they would be recorded as possible enhancements to the program.

System Design

After determining the second step and subtasks, USACERL and AIS further defined parts of the software program, briefly described as:

Pseudo Code. AIS set up screens on the penbased laptop computer to figure the correct data flow. USACERL tested these screens to ensure that the data flowed correctly.

Database Schema. Using the data dictionaries from the previous steps, AIS set up the database structure.

Final Prototype. AIS developed a prototype, which USACERL tested and found acceptable.

Test Data. Since no buildings or facilities existed nearby to test the prototype on, USACERL and AIS used some "dummy" data to preliminary test the program.

Code/Testing Plan (Top-down). USACERL tested the code by starting at the highest building level and working down.

Problem Management/Resolution Plan. USACERL developed and implemented a problem management and resolution plan.

Coding/Testing

After determining the third step and subtasks, USACERL and AIS further defined the parts of the software program, briefly described as:

Actual System. From the previous steps, AIS wrote the code for the program.

Functional Validation Results. AIS did some preliminary testing of the program at Peoria, IL. USACERL did the rest of the preliminary testing at Champaign, IL and found that the program functioned correctly.

Stress Test Results. USACERL used developed data to stress test the program, which passed all tests.

Version Control Plan. AIS and USACERL decided there would not be a version control plan for this program.

Detailed Acceptance/Implementation Plan. After extensive preliminary testing, USACERL accepted the program.

Implementation

After determining the fourth step and subtasks, USACERL worked on completing the step and its associated subtasks, as follows:

Testing Results. After accepting the program, USACERL tested it at Fort Sheridan. Test results are discussed in Chapter 5 and Appendix C. USACERL did further testing of the program at Fort Ord. Test results are discussed in Chapter 6 and Appendix D.

Production, Distribution, and Technology Transfer Plan. USACERL decided that the program should be transferred by including a program disk with the final technical report (see **Mode of Technology Transfer**, pp 8-9).

Software Support. USACERL is responsible for all software support.

Enhancement Plan. USACERL is responsible for making enhancements to the program as funding is available.

4 Program Description

This chapter gives a brief description of and a user's guide to the computerized layaway program.

Introduction

The opening screen (Figure 1) welcomes the user to the program with the Corps of Engineers castle and a list of several choices. The user uses a "pen" to make a choice by pressing the computer screen. The possible choices on this screen are:

- "Add a Building" to add a building that does not exist in the program
- "Change Building Info" to change the information on an existing building
- "Inspect a Building" to inspect a building to be laid away, one that is laid away, or one that is going to be reactivated

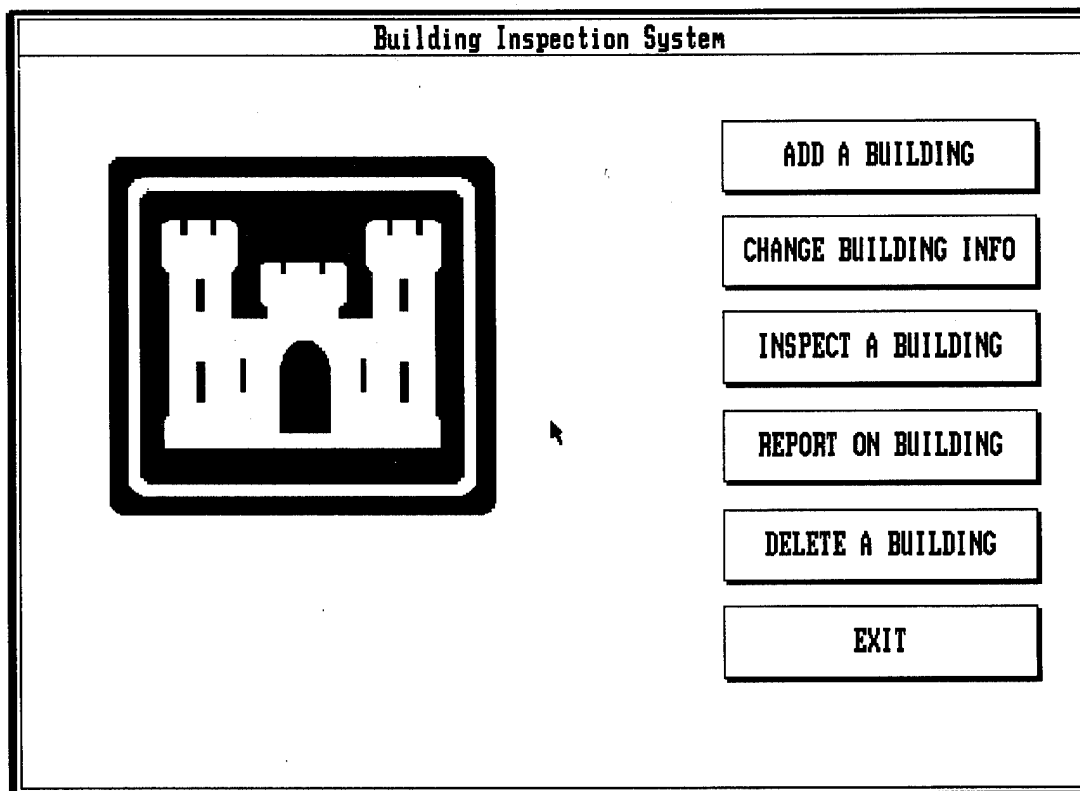

Figure 1. First screen of layaway program.

- “Report on Building” to give an inspection report
- “Delete a Building” to delete an existing building
- “Exit” to exit the program.

Inventory Screens

The next few screens deal with entering inventory data for the historical building. By choosing “Add a Building,” the screen in Figure 2 appears and waits for a building name and number to be entered. A number *must* be entered before going on. This screen will also ask for a particular layaway scenario. Once the user selects the scenario, (1) additional inventory information may be entered on “Next Screen,” (2) the information may be saved, (3) “Main Menu” may be selected, or (4) the user may proceed directly to the inspection by selecting “Inspect.”

By choosing “Next Screen,” the screen in Figure 3 appears. It gives the building name and number, and asks if it resides in a particular historic zone and for the address of the building (if it exists). This information is not mandatory. After entering the data, the user may (1) proceed to the “Next Screen” to enter additional information, (2) return to the “Previous Screen” to enter more data, (3) save the data for later by going to the “Main Menu,” or (4) begin the inspection process by selecting “Inspect.” If the

Building Information

Building Name _____

Building Id 0510

Strategy

Less than 90 days

Less than 1 year

Greater than 1 year

Inspection Type

Deactivate

Periodic

Reactivate

Active

Next Screen Main Menu Inspect

Figure 2. Building information screen.

Building Information					
Building Name					
Zone	_____				
Address	Tooele Army Depot _____				
Street Address	_____				
City/State	Tooele, UT _____				
Zip	84704-5000 _____				
<table border="0"> <tr> <td><input type="button" value="Next Screen"/></td> <td><input type="button" value="Main Menu"/></td> </tr> <tr> <td><input type="button" value="Previous Screen"/></td> <td><input type="button" value="Inspect"/></td> </tr> </table>		<input type="button" value="Next Screen"/>	<input type="button" value="Main Menu"/>	<input type="button" value="Previous Screen"/>	<input type="button" value="Inspect"/>
<input type="button" value="Next Screen"/>	<input type="button" value="Main Menu"/>				
<input type="button" value="Previous Screen"/>	<input type="button" value="Inspect"/>				

Figure 3. Building location screen.

user selects "Change Building Info" from the first screen (Figure 1), Figure 3 would be the next screen the user would see.

If the user selected "Next Screen" from Figure 3, the screen in Figure 4 would appear. It gives the building name and ID and asks for the square footage, the number of stories, the year it was built, the construction code, the architect or drawing number, and the building POC and telephone number. If the user "double clicks" on the style box, a choice of the common styles of buildings appears. If the user has a style that is not listed, they should pick the closest one. Once again, no fields are mandatory and the user has four choices: "Next Screen," "Previous Screen," "Main Menu," and "Inspect."

The screen in Figure 5 is the final inventory screen. When users select the category code, they must select the appropriate code for the building. If there are several category codes, the user may select only one (i.e., the primary category code). By selecting a category code, the category description is automatically entered by the computer. Then the user can enter any building description that they would like. There are now three choices to select from: "Previous Screen," "Main Menu," or "Inspect."

Building Information	
Building Name	
Square Footage	10,800 Number of Stories 1
Year Built	1943 Construction Code T
Architect\Drawing	#T34-55 through #T35-45
Style	Federal
Bldg. POC Name	Steve Cask
Bldg. POC Phone	374-3716
<input type="button" value="Next Screen"/> <input type="button" value="Main Menu"/> <input type="button" value="Previous Screen"/> <input type="button" value="Inspect"/>	

Figure 4. Additional building information screen.

Building Information	
Building Name	
Category Code	141 84
Category Description	Group Headquarters Building
Description	This was the first building built at Tooele Army Depot. It is of frame construction with a built up roof. Since construction it has housed the Facilities Engineering Division. It is a very good place to work.
<input type="button" value="Previous Screen"/> <input type="button" value="Main Menu"/> <input type="button" value="Inspect"/>	

Figure 5. Final building information screen.

Inspection

To access the inspection process, select "Inspect a Building" from the first screen (Figure 1) or "Inspect" from any of the inventory screens.

It is important for the user to select the right system/component/subcomponent during the inspection process. Therefore, the first few screens of the inspection process lead the user to select the correct inspection list. Figure 6 shows the first inspection screen. From this screen, the user may return to the main menu or double click on a system and continue to the next screen (Figure 7) to select a component for inspection. This screen allows the user to select a component, return to the "System" menu and select another system, or return to the main menu.

After selecting a component, the screen in Figure 8 will appear. The user will be able to select a particular subcomponent. If there are more subcomponents than can show on the screen, the user will be able to move through the list by pushing the "Page Up," and "Page Down" keys. The user also will be able to return to the component and system screen or return to the main menu. To help the inspector remember the distress location, a "sample unit" number can be entered. The sample unit can be any number but is usually the room number where the distress is located.

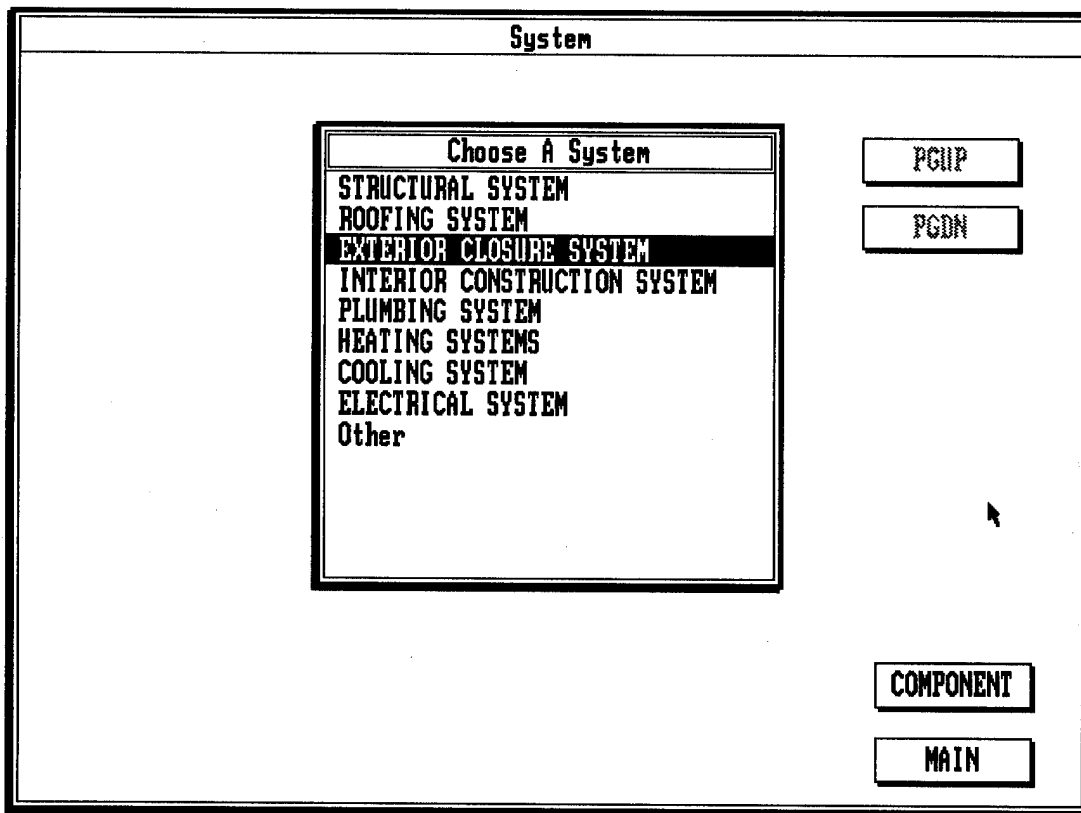

Figure 6. System selection screen.

Component														
System : EXTERIOR CLOSURE SYSTEM														
<table border="1"> <thead> <tr> <th>Choose A Component</th> </tr> </thead> <tbody> <tr> <td>EXTERIOR PERIMETER</td> </tr> <tr> <td>EXTERIOR WALL SURFACES</td> </tr> <tr> <td>EXTERIOR WINDOWS AND LOUVERS</td> </tr> <tr> <td>EXTERIOR DOORS</td> </tr> <tr> <td>EXTERIOR DECKING</td> </tr> <tr> <td>EXTERIOR CEILINGS</td> </tr> </tbody> </table>	Choose A Component	EXTERIOR PERIMETER	EXTERIOR WALL SURFACES	EXTERIOR WINDOWS AND LOUVERS	EXTERIOR DOORS	EXTERIOR DECKING	EXTERIOR CEILINGS	<table border="1"> <tr> <td>PGUP</td> </tr> <tr> <td>PGDN</td> </tr> <tr> <td> </td> </tr> <tr> <td>SYSTEM</td> </tr> <tr> <td>SUBCOMPONENT</td> </tr> <tr> <td>MAIN</td> </tr> </table>	PGUP	PGDN		SYSTEM	SUBCOMPONENT	MAIN
Choose A Component														
EXTERIOR PERIMETER														
EXTERIOR WALL SURFACES														
EXTERIOR WINDOWS AND LOUVERS														
EXTERIOR DOORS														
EXTERIOR DECKING														
EXTERIOR CEILINGS														
PGUP														
PGDN														
SYSTEM														
SUBCOMPONENT														
MAIN														

Figure 7. Component selection screen.

SubComponent																					
System : EXTERIOR CLOSURE SYSTEM																					
Component : EXTERIOR WALL SURFACES																					
<table border="1"> <thead> <tr> <th>Choose A Subcomponent</th> </tr> </thead> <tbody> <tr> <td>CONCRETE SURFACES</td> </tr> <tr> <td>CEMENTITIOUS COATING</td> </tr> <tr> <td>CONCRETE MASONRY & GLASS BLOCK UN</td> </tr> <tr> <td>BRICK MASONRY UNITS</td> </tr> <tr> <td>ADOBE UNIT MASONRY</td> </tr> <tr> <td>TERRA COTTA MASONRY</td> </tr> <tr> <td>EXTERIOR CERAMIC TILE</td> </tr> <tr> <td>METAL CLADDING & METAL PANELS</td> </tr> <tr> <td>VINYL CLADDING</td> </tr> <tr> <td>WOOD CLADDING</td> </tr> <tr> <td>LINTELS & SILLS</td> </tr> <tr> <td>MISCELLANEOUS METALS</td> </tr> </tbody> </table>	Choose A Subcomponent	CONCRETE SURFACES	CEMENTITIOUS COATING	CONCRETE MASONRY & GLASS BLOCK UN	BRICK MASONRY UNITS	ADOBE UNIT MASONRY	TERRA COTTA MASONRY	EXTERIOR CERAMIC TILE	METAL CLADDING & METAL PANELS	VINYL CLADDING	WOOD CLADDING	LINTELS & SILLS	MISCELLANEOUS METALS	<table border="1"> <tr> <td>PGUP</td> </tr> <tr> <td>PGDN</td> </tr> <tr> <td> </td> </tr> <tr> <td>SYSTEM</td> </tr> <tr> <td>COMPONENT</td> </tr> <tr> <td>SAMPLE UNIT</td> </tr> <tr> <td>MAIN</td> </tr> </table>	PGUP	PGDN		SYSTEM	COMPONENT	SAMPLE UNIT	MAIN
Choose A Subcomponent																					
CONCRETE SURFACES																					
CEMENTITIOUS COATING																					
CONCRETE MASONRY & GLASS BLOCK UN																					
BRICK MASONRY UNITS																					
ADOBE UNIT MASONRY																					
TERRA COTTA MASONRY																					
EXTERIOR CERAMIC TILE																					
METAL CLADDING & METAL PANELS																					
VINYL CLADDING																					
WOOD CLADDING																					
LINTELS & SILLS																					
MISCELLANEOUS METALS																					
PGUP																					
PGDN																					
SYSTEM																					
COMPONENT																					
SAMPLE UNIT																					
MAIN																					

Figure 8. Subcomponent selection screen.

Once a subcomponent is selected, the screen in Figure 9 will appear. The screen shows the actual distresses the inspector needs to look for and accepts records of the amount of distress present. The user may change subcomponents, components, systems, sample units, or return to the main menu. If there are more distresses than can show on the screen, the user will be able to move through them by using the Page Up and Page Down keys.

After the inspection is complete, the inspector will be able to return to the office and print either the distress report or the M&R report shown in Figure 10. This screen is accessed by going to the main menu (Figure 1) and selecting "Report on Building." The distress report simply lists all the distresses and quantities that the inspector found per building. The M&R report shows what should be done to repair the distresses per building.

Distresses	
System : EXTERIOR CLOSURE SYSTEM	Sample Unit : 1
Component : EXTERIOR WALL SURFACES	
Subcomponent : BRICK MASONRY UNITS	
Cracks & holes.	
Quantity <input style="width: 30px; border: 1px solid black;" type="text"/>	Units of Measure <input style="width: 30px; border: 1px solid black;" type="text"/>
Broken or missing units.	
Quantity <input style="width: 30px; border: 1px solid black;" type="text"/>	Units of Measure <input style="width: 30px; border: 1px solid black;" type="text"/>
Efflorescence; locate source of water penetration.	
Quantity <input style="width: 30px; border: 1px solid black;" type="text"/>	Units of Measure <input style="width: 30px; border: 1px solid black;" type="text"/>
Quantity <input style="width: 30px; border: 1px solid black;" type="text"/>	Units of Measure <input style="width: 30px; border: 1px solid black;" type="text"/>

SYSTEM

COMPONENT

SUBCOMP

SAMPLE UNIT

MAIN

TOP

MORE

Figure 9. Distress selection screen.

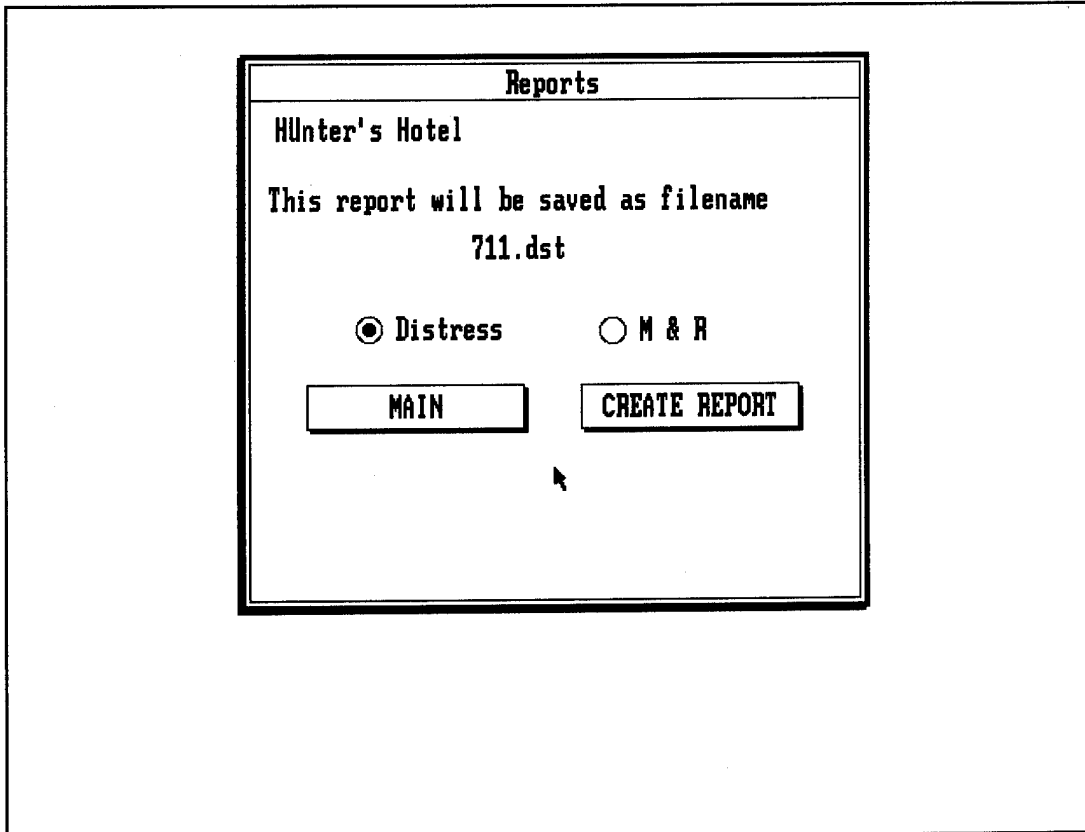

Figure 10. Report selection screen.

5 Testing at Fort Sheridan

Introduction

The 20 buildings that USACERL used for testing at Fort Sheridan are part of a National Historic Landmark. In April 1993, USACERL and Fort Sheridan personnel inspected 10 family housing units, five administrative buildings, one jail, one warehouse, and three other buildings. The inspection followed the guidelines outlined for the different building systems, components, and subcomponents from Volume II of Uzarski et al. (1991) and Hunter et al. (1992). Highlights from that inspection and comments from Fort Sheridan personnel follow. The inspection results for selected buildings are in Appendix C. Appendix A is a list of all systems, components, and subcomponents.

Exterior Closure System

Fort Sheridan personnel considered this system important to the inspection of a laid away building because of the necessity to protect the interior of the building from weather and intruders. Highlights of individual components and subcomponents follow.

Exterior Perimeter Component

Fort Sheridan personnel felt that certain subcomponents should be eliminated in this component. These subcomponents included: vehicle bumper guards; steel, wood, and concrete dock bumpers; trees and shrubs; and finish grade.

Fort Sheridan personnel did not layaway the remaining subcomponents of this component because the caretaker force left behind to maintain the installation in the laid away state will maintain these subcomponents as if they were "active."

Exterior Wall Components

DPW personnel at Fort Sheridan felt this was the most important component of this system because of the need to keep weather and intruders out of laid away buildings. USACERL and DPW personnel inspected the brick masonry, gutters and downspouts,

and lintels and sills. Personnel did not inspect other subcomponents of this component because they do not exist at this site.

Exterior Window and Louver Components

Fort Sheridan personnel rated this component equal to exterior doors that need inspection on a laid away building because of the need to keep weather and intruders out. USACERL and DPW personnel inspected the glass and glazing, aluminum windows, wood windows, window hardware, and caulking. The other subcomponents do not exist at this location and therefore were not part of this test.

Fort Sheridan personnel felt that certain subcomponents listed in Volume II of Uzarski et al. (1991), Hunter et al. (1992), and Appendix A were really not subcomponents. They are smaller divisions of the listed subcomponents and should be included as distresses and maintenance guidelines of those subcomponents. These items include caulking, glass and glazing, and window hardware.

Exterior Door Components

Fort Sheridan personnel rated this component equal with exterior windows and louvers that need inspection on a laid away building because of the need to keep weather and intruders out. USACERL and Fort Sheridan inspected the hollow metal doors and frames, wood doors and frames, screen doors, glass in doors, door hardware, and caulking subcomponents. The other subcomponents do not exist at this location and therefore were not part of this test.

DPW personnel at Fort Sheridan felt that certain subcomponents (i.e., caulking, glass in doors, and door hardware) listed in Volume II of Uzarski et al. (1991), Hunter et al. (1992), and Appendix A were not subcomponents. They are smaller divisions of the listed subcomponents and should be included with those subcomponents. When inspecting a wood door, for example, the distresses of door hardware, glass in doors, and caulking are included as distresses of that wood door and not as separate items.

Roofing System

Fort Sheridan personnel felt this was an important part of the laid away building to inspect because the roof protects the building interior from weather and intruders. If the roof system is not leaking, there is a good possibility that the interior system is not quickly deteriorating. Only one subcomponent listed in Volume II of Uzarski et al. (1991), Hunter et al. (1992), and Appendix A was available for inspection at this site.

Shingled Roofing Component

Because of difficulties getting on the roofs (most buildings were two stories) and the slope of the roof (three in 12 to six in 12), it was impractical to do closeup roof inspections. Personnel inspected all the subcomponents from ground level; therefore, the inspection did not find many distresses.

Fort Sheridan personnel felt that certain subcomponents listed in Volume II of Uzarski et al. (1991), Hunter et al. (1992), and Appendix A were really not subcomponents. They felt that the subcomponents of caulking, clawing, improper nailing/nail rejection, breakage/damage, blistering, and loose tabs are really distresses of asphalt shingles and not subcomponents.

Interior Construction System

Fort Sheridan personnel felt that the importance of inspecting this component depended on whether the interior of the building was the same or very nearly the same as when the building was constructed. If so, it would be historic and need inspection; but if the interior of the building had been modified, it would not be important and would not need inspection.

Wall Components

The only wall subcomponent that inspection personnel encountered at this test site was gypsum wallboard. This subcomponent was in buildings where alterations had changed the interiors so that they were no longer important; therefore, inspection was not considered important. For the purposes of the software program, however, personnel inspected this subcomponent.

USACERL encountered a subcomponent that was not in the existing lists of horsehair plaster walls. This subcomponent was encountered mostly in the family housing units where interior alterations had not infringed on the historic character of the building. USACERL recorded the distresses of the plaster on a separate paper for further review and consideration.

Floor and Base Components

USACERL inspected the subcomponents of resilient tile and resilient flooring, carpet, wood flooring, and vinyl and wood bases. The other subcomponents do not exist at this location and therefore were not part of this test.

Fort Sheridan personnel felt that the base subcomponent listed in Volume II of Uzarski et al. (1991), Hunter et al. (1992), and Appendix A was not a subcomponent. Bases are really a part of the different types of flooring and base distress should be included as distresses of the flooring. When inspecting a wood floor, for example, the distresses of the bases are included as distresses of that wood floor and not as separate items.

Ceiling Components

Personnel inspected the subcomponents of gypsum board ceilings and suspended acoustical ceilings. The other subcomponents do not exist at this location and therefore were not part of this test.

USACERL encountered a horsehair plaster ceiling subcomponent that is not on existing lists. This subcomponent was encountered mostly in the family housing units where interior alterations had not infringed on the historic character of the building. USACERL recorded the distresses of the plaster on a separate sheet for further review and consideration.

Door Components

Fort Sheridan personnel felt this was a very important component that needs inspection in a laid away building. The inspection is not to record the distresses, but to ensure that the doors are braced open to allow passive ventilation in the building.

USACERL inspected the subcomponents of hollow metal doors and frames, wood doors and frames, glass in doors, door hardware, and caulking. The other subcomponents do not exist at this location and therefore were not part of this test.

Fort Sheridan personnel felt that the subcomponents of caulking, glass in doors, and door hardware listed in Volume II of Uzarski et al. (1991) and Hunter et al. (1992) are not subcomponents. They are smaller divisions of the listed subcomponents and should be included as distresses and maintenance guidelines of those subcomponents. When inspecting a wood door, for example, the distresses of the caulking, glass in doors, and door hardware are included as distresses of that wood door and not as separate items.

Specialties Components

Fort Sheridan personnel felt that this component should be eliminated because certain subcomponents are pieces of equipment and would be removed from the building as the tenants leave. These subcomponents include metal lockers, fire protection

cabinets, storage shelving, casework, Venetian blinds, and closet specialties. Other subcomponents really should be included in appropriate components in other systems. These subcomponents include metal toilet partitions, toilet and bath accessories, louvers, and bleachers. USACERL inspected metal toilet partitions and toilet and bath accessories and included encountered distresses under the plumbing system.

Exposed Structural Elements Components

The historical buildings at Fort Sheridan did not have any exposed structural subcomponents to inspect.

Plumbing

The plumbing systems for all of the laid away buildings inspected at Fort Sheridan had followed the shutdown procedures as outlined except that propylene glycol was not used to seal the traps as outlined in the procedures. An environmentally acceptable substitute was used for the glycol. Also, all the valve packing and washers were not packed as recommended because Fort Sheridan personnel felt that the buildings would be laid away less than 6 months and packing was not necessary.

Fort Sheridan personnel found that many historic plumbing fixtures (such as bathtubs with lion claw legs) were being stolen out of the buildings after they had been laid away. Often it is difficult to replace these items. If historic plumbing fixtures exist in laid away buildings, special security considerations need to be enforced so these items will not be stolen.

HVAC System

U.S. Army Forces Command (FORSCOM) regulations require that Fort Sheridan maintain the temperature of all laid away historic buildings at 55 °F (13 °C) for the winter. Therefore, USACERL could not test the heating, ventilating, and air conditioning (HVAC) part of the layaway guidelines.

FORSCOM regulations were not without complications. Fort Sheridan turned on the heat to the laid away buildings on 15 October. Three months later, when inspection occurred, steam heat was found to be leaking in one building. Water clung to the ceiling and walls. It took emergency procedures to stop the steam leak, clean up the water, and do repairs. If laid away buildings require heat, then personnel need to inspect the laid away facilities on a frequent basis or set up remote monitors to prevent similar situations from happening.

Electrical System

FORSCOM regulations require that Fort Sheridan maintain the temperature of all the laid away historic buildings at 55 °F (13 °C). The electrical system was needed to keep the boilers running in the buildings; therefore, USACERL could not test the layaway electrical guidelines. Fort Sheridan also did not lay away this system so lights and power would be available for any inspector or repair crew that might come through.

Fort Sheridan personnel felt that some of the electrical system could be disconnected—especially some of the circuits for lights and duplex outlets. However, since they had not labeled most of the circuit breaker boxes, it would take time to determine exactly what was on each circuit and to decide if they could disable the circuit. The number of personnel and time available made this an impractical choice.

Other Building Issues

While personnel conducted the inspection, they observed other layaway issues that needed addressing. The four specific areas to address are security, ventilation, personnel, and the “do-nothing” maintenance style.

Security

Security became a big issue as Fort Sheridan was closing. As personnel left the installation, vacated buildings were turned over to the DPW to lay away. After the buildings were laid away, several instances occurred where the buildings were entered. The locks on the buildings were changed, but this did not work because individuals went through the windows. When the windows were nailed shut with 16-penny nails, the security issues were resolved. However, this solution created other problems explained in the next section.

Ventilation

An important feature of a laid away building is ventilation, which will help circulate air, dry wet spots, and possibly slow the deterioration rate. Volume II of Uzarski et al. (1991) and Hunter et al. (1992) explain the importance of different types of passive and active ventilation. Fort Sheridan recognized the importance of passive ventilation and left the windows open slightly to allow air to flow through the buildings. When they became a security problem, the windows were nailed shut, effectively shutting off the ventilation. This resulted in water damage when the steam leak mentioned earlier caused condensation to form in the absence of adequate ventilation.

Personnel

To be done correctly, building layaway and closing requires an adequate number of personnel. As personnel left Fort Sheridan, those that remained had to carry on required tasks. The workforce shrank drastically, making it difficult for facility personnel to properly manage the laid away buildings. Since there were not enough personnel to manage the laid away buildings, the DPW accepted the "do-nothing" style of managing.

"Do-nothing" Management

As explained in the previous layaway reports, the "do-nothing" management style is not the recommended way to manage laid away buildings. Buildings that are laid away without further inspection or maintenance can have numerous problems, such as the steam leak mentioned earlier. An active layaway inspection procedure may have avoided this.

Program Issues

Inspectors found the computerized guidelines easy to use in the field. However, one drawback of using the penbased laptop computer is that the battery has a very short life of only 1-1/2 to 2 hours. While inspectors were using one battery, another was being recharged. This could be a problem if electricity is also laid away.

Another problem with the program was the inability to keep track of the exact location of the distress encountered inside a building. The best way to resolve this would be to increase the sample location field size.

After each building was inspected, a report on the encountered distresses and M&R was run. Appendix A shows an excerpt of the lengthy reports.

Inspection personnel felt that the software program helped explain and clarify the guidelines set forth in Volume II of Uzarski et al. (1991) and Hunter et al. (1992). They also felt that computerizing the guidelines made keeping track of the distresses easier than taking "mounds" of paper into the field to help track all the distresses.

Summary

Comments from the field test indicated that the program has good potential to be a useful field tool.

6 Testing at Fort Ord

Introduction

The 35 buildings that USACERL used for testing at Fort Ord are eligible to be on the National Register. They consisted of 34 buildings at East Garrison (the original part of Fort Ord) and Stillwell Hall, a noncommissioned officer (NCO) club. As with the inspection at Fort Sheridan, the inspection followed the distress and M&R guidelines outlined for the different building systems, components, and subcomponents from Volume II of Uzarski et al. (1991) and Hunter et al. (1992). The highlights and comments from the inspection follow. The inspection results from the program for selected buildings are in Appendix D.

Exterior Closure System

Again, DPW inspection personnel considered this to be an important system of a laid away building to inspect because of the necessity to protect the interior of the building from weather and intruders. Highlights of the individual components and sub-components follow.

Exterior Perimeter Component

Fort Ord personnel were not going to lay away any exterior perimeter components, so they were not inspected.

Exterior Wall Components

The only wall subcomponents that inspection personnel encountered at this test site were cast-in-place concrete, stucco, adobe, gutters and downspouts, and lintels and sills. Other subcomponents were not inspected because they do not exist at this site.

Exterior Window and Louver Components

Personnel could only inspect the glass and glazing, aluminum windows, wood windows, window hardware, and caulking of Stillwell Hall. Windows at East Garrison were

either boarded up or missing and could not be rated. The other subcomponents do not exist at this location and therefore were not part of this test.

Exterior Door Components

Inspection personnel could only inspect wood doors, glass in doors, door hardware, and caulking at Stillwell Hall. The doors at East Garrison were boarded and could not be rated. Other subcomponents do not exist at this location and therefore were not part of this test.

Roofing System

Fort Sheridan personnel felt this was an important part of the laid away building needing inspection because the roof protects the building interior from weather and intruders. Since the roof system was not leaking, there was a good possibility that the interior system was not deteriorating at a fast rate. None of the components listed in Volume II of Uzarski et al. (1991) and Hunter et al. (1992) were available for inspection at this site. Inspection personnel encountered a new component of clay tile roofing. Inspection personnel recorded the visible distresses of the clay tile roofing on a separate paper for further review and consideration.

Interior Construction System

Only the interior construction system of Stillwell Hall was open for inspection. The buildings on East Garrison were secured and unavailable for inspection. The following, therefore, are comments from the inspection of Stillwell Hall.

Wall Components

Inspection personnel encountered horsehair plaster walls that are not a subcomponent of existing lists. USACERL recorded the distresses of the plaster on a separate paper for further review and consideration.

Floor and Base Components

USACERL inspected the subcomponents of resilient tile and resilient flooring, carpet, wood flooring, and vinyl and wood bases. The other subcomponents do not exist at this location and therefore were not part of this test.

Ceiling Components

Personnel inspected the subcomponents of gypsum board ceilings and suspended acoustical ceilings. The other subcomponents do not exist at this location and therefore were not part of this test.

USACERL encountered horsehair plaster ceilings that are not a subcomponent on existing lists. USACERL recorded the distresses of the plaster on a separate sheet for further review and consideration.

Door Components

USACERL inspected the subcomponents of hollow metal doors and frames, wood doors and frames, glass in doors, door hardware, and caulking. The other subcomponents do not exist at this location and therefore were not part of this test.

Specialties Components

Fort Ord personnel were not going to lay away any speciality components, so no inspection took place for this component.

Exposed Structural Elements Components

The only visible subcomponent was wood trusses. The other subcomponents do not exist at this location and therefore were not part of this test.

Plumbing

The plumbing systems for all of the laid away buildings in the East Garrison either did not exist or had been removed when the building was laid away. When Stillwell Hall was inspected, it was still an "active" building and shutdown procedures did not apply.

HVAC System

The HVAC systems for all of the laid away buildings in the East Garrison either did not exist or had been removed when the building was laid away. When Stillwell Hall was inspected, it was still an "active" building and shutdown procedures did not apply.

Electrical System

The electrical systems for all of the laid away buildings in the East Garrison either did not exist or had been removed when the building was laid away. When Stillwell Hall was inspected, it was still an "active" building and shutdown procedures did not apply.

Other Building Issues

Ventilation

An important feature of a laid away building is ventilation, which will help circulate air, dry wet spots, and possibly slow the deterioration rate. Volume II of Uzarski et al. (1991) and Hunter et al. (1992) explain the importance of different types of passive and active ventilation. Fort Ord personnel did not feel that passive ventilation was important and boarded up all the windows. USACERL researchers feel this will lead to increased deterioration of the building interiors and loss of historic character.

Program Issues

Inspection personnel felt that using the computerized procedures made the previously developed guidelines easier to understand. However, one drawback of using the penbased laptop computer is that any given battery has only 1-1/2 to 2 hours of battery life. While inspectors were using one battery, another battery was being recharged in the car cigarette lighter.

Another problem with the program was the inability to keep track of the exact location of the distresses encountered inside a building. The best way to resolve this would be to increase the sample location field size.

After each building was inspected, a report on the encountered distresses and M&R was run. Appendix B shows an excerpt of the lengthy reports.

Summary

Comments from the field test indicated that the program has good potential to be a useful field tool.

7 Conclusions, Recommendations, and Final Observations

Conclusions

The following conclusions were drawn based on testing the computerized guidelines at Forts Sheridan and Ord:

1. Inspectors found the computerized guidelines much easier to use than the manual versions of the layaway reports.
2. The GRIDPAD® works well for field inspection; however, it has a short battery life.

Recommendations

USACERL researchers make the following recommendations concerning historic building layaway:

1. Further research should expand this study. Because of the limited scope of Hunter et al. (1992), the procedures therein are interim. Further field testing of Hunter et al. (1992) should include different types of facilities and materials. Further research should also study and incorporate the different regional factors that affect facility degradation. Also, further research should include cost analyses to help with budget planning and M&R strategy development.
2. Controlled testing of these procedures should continue at one or more sites. This testing should consist of inspection and monitoring of laid away building systems and components to determine deterioration modes and rates of deterioration.
3. If GRIDPAD® is to be used in inspection, additional batteries and battery chargers will be required.

Final Observations

1. Installations must NOT pursue a "do-nothing" approach in laying away and maintaining historic buildings.
2. Historic buildings that are to remain in the Army inventory in a laid away status should have complete condition and M&R strategy evaluations performed on them before the installation lays them away. The installation should consult the SHPO before performing evaluations.
3. If the installation does not periodically inspect laid away facilities, inspections must start as soon as possible.
4. The entire topic of historic layaway should be part of an expanded study of BRAC-related issues. This expanded study should include facilities not addressed in this report and serve to validate the procedures described herein.
5. Further research on the economics of historic facility layaway as part of M&R strategy development should be conducted. This will ease the budget planning process to ensure that installations allocate the proper funding levels for maintaining laid away historic buildings.
6. Checklist procedures from Volume II of Uzarski et al. (1991) and Hunter et al. (1992) should be enlarged to include new materials (such as horsehair plaster and clay tile roofs) found in this field test or to eliminate the subcomponents that do not apply (i.e., dock bumpers, trees and shrubs of exterior perimeter, and clawing and blistering of shingle roofing).
7. Further research should be conducted to determine the best method of passive ventilation for historic buildings.
8. Further research should be conducted to determine the number of personnel required to maintain a laid away historic building in a certain condition. Also, research should be conducted to determine types of technology available and test the technology that will help maintain laid away buildings.
9. Training sessions should be conducted to help installations properly lay away historic buildings. Training materials such as video cassette tapes and demo disks should be developed.
10. The software program should be improved to generate additional reports.
11. The systems, components, and subcomponents need review and modification to place them in the correct order in the computer program. For example, the exterior perimeter component should be eliminated from building inspection, and the distresses of the subcomponents of door hardware and glass in doors should be combined with the distresses of the door.

References

Cited

Army Regulation (AR) 210-17, *Inactivation of Installations* (Headquarters, Department of the Army [HQDA], Washington, DC, January 1967).

"Base Realignment and Closures, Report of the Defense Secretary's Commission" (Department of Defense [DOD], December 1988).

Code of Federal Regulations (CFR), title 36, part 800.

"Defense Base Closure and Realignment Commission, Report to the President" (DOD, July 1991).

"Department of Defense, Base Closure and Realignment Report" (DOD, March 1993).

Hunter, S.L., et al. *Layaway Procedures for U.S. Army Facilities: Inspection, Maintenance, and Repair of Historic Facilities*, Draft Interim Report, FM-92/DRAFT (U.S. Army Construction Engineering Research Laboratories [USACERL], September 1992).

National Historic Preservation Act of 1966, as amended (Public Law 89-665, 15 October 1966), 80 Stat. 915 to 919..

Pressman, R.S., *Software Engineering: A Practitioner's Approach* (McGraw-Hill, Inc. 1992).

"Section 106, Step-by-Step" (Advisory Council of Historic Preservation, Washington, DC, October 1986).

Technical Note (TN) 420-10-08, *Facilities Operations, Maintenance, and Repair Policies for Base Realignment and Closing Installations* (U.S. Army Engineering and Housing Support Center, 1 October 1992).

Uzarski, D.R., et al., *Layaway Procedures for U.S. Army Facilities, Volume I: Decision Criteria and Economics*, Technical Report (TR) M-91/23/ADA240054 (USACERL, July 1991).

Uzarski, D.R., et al., *Layaway Procedures for U.S. Army Facilities, Volume II: Inspection and Maintenance and Repair Checklists*, TR M-91/23/ADA239849 (USACERL, July 1991).

Uncited

Bailey, D.M., D.E. Brotherson, W. Tobiasson, A. Knehans, *ROOFER: An Engineered Management System (EMS) for Bituminous Built-Up Roofs*, USACERL TR M-90/04/ADA218529 (USACERL, December 1989).

Building Research Board, *Committing to the Cost of Ownership-Maintenance and Repair of Public Buildings* (National Academy Press, 1990).

Burns, John A., *Recording Historic Structures* (American Institute of Architects Press, 1989).

Federal Register (FR), vol 48, pp 44716-44742.

FR, vol 51, p 31118.

Fisher, C.E. and T.A. Vitana, "Temporary Window Vents in Unoccupied Historic Buildings," *Preservation Tech Notes* (National Park Service, U.S. Department of the Interior, 1985).

Hoke, John Ray, *Architectural Graphic Standards*, 8th ed. (American Institute of Architects, 1988).

"How To Apply the National Register Criteria for Evaluation" (National Park Service, U.S. Department of the Interior, June 1, 1982).

Liska, R.W., *Means Facilities Maintenance Standards* (R.S. Means Company, Inc., 1988).

Maintenance and Layaway of Government-Owned, Contractor-Operated Facilities, AMC-P 235-1 (Army Materiel Command [AMC], July 1990).

Manual of Roof Maintenance and Roof Repair (National Roofing Contractors Association and Asphalt Roofing Manufacturers Association, January 1981.)

Meier, H.W., *Construction Specifications Handbook*, 3rd ed. (Prentice-Hall, Inc., 1983).

Meredith, D.D., K.W. Wong, R.W. Woodhead, and R.H. Wortman, *Design & Planning of Engineering Systems*, 2nd ed. (Prentice-Hall, Inc., 1985).

Naval Facilities Engineering Command (NAVFAC), *Preventive Maintenance Inspection - Development and Implementation Guide for Facility Managers*, (NAVFAC-Chesapeake Division, September 1990).

NAVFAC, *Inactivation, Caretaker Maintenance, and Reactivation of Shore Facilities*, NAVFAC MO-300 (NAVFAC, September 1980).

NAVFAC, *Inspection of Shore Facilities: Vol 1*, MO-322 (NAVFAC, July 1987).

Neely, E.S., R.D. Neathammer, J.R. Stirn, *Maintenance Resource Prediction Model (MRPM) User's Manual*, ADP Report P-91/12/ADA232019 (USACERL, January 1991).

Shahin, M.Y., D.M. Bailey, and D.E. Brotherson, *Membrane and Flashing Condition Indexes for Built-Up Roofs, Volume 1: Development of the Procedure*, TR M-87/13/ADA190367 (USACERL, September 1987).

"The Development of Standards and the Analysis of Costs Related to the Mothballing of World War II Facilities," Study Preliminary Submittal (Harland Bartholomew & Associates, Inc., August 1989).

Shahin, M.Y., D.M. Bailey, D.E. Brotherson, *Membrane and Flashing Condition Indexes for Built-Up Roofs, Volume 2: Inspection and Distress Manual*, TR M-87/13/ADA190367 (USACERL, September 1987).

"Standards and Guidelines for Archeology and Historic Preservation" (U.S. Department of the Interior, undated).

Uzarski, D.R., E.D. Lawson, M.Y. Shahin, and D.E. Brotherson, *Development of the BUILDER Engineered Management System for Building Maintenance: Initial Decision and Concept Report*, TR M-90/19/ADA225950 (USACERL, July 1990).

Uzarski, D.R., and S.L. Hunter, *Development of the BUILDER Engineered Management System for Building Maintenance: Status and Future Direction*, Draft TR FM-93/DRAFT (USACERL, August 1993).

Appendix A: Systems, Components, and Subcomponents

System	Component	Subcomponent
Structural System	Roof structure	Roof rafters and purlins Trusses
	Joists, beams, and girders	Joists, beams, and girders
	Columns	Columns
Roofing Systems	Built-up roofing	Base flashing Blisters Debris and vegetation Embedded edge metal Flashed penetrations Holes Improper equipment supports Metal cap flashing Patching Pitch pans Ridging Slippage Splits Surface deterioration Wet insulation
	Shingles	Blistering Breakage/damage Caulking Clawing Debris and vegetation Flashed penetrations Ice dams Improper equipment supports Improper nailing/nail rejection Loose tabs Metal cap flashing Step flashing Valley flashing
	Roof drainage	Flashing and counterflashing Gutters and downspouts

Exterior Closure System	Exterior perimeter	Area drains and catch basin Caulking Concrete stairs and retaining walls Dock bumpers Exterior signs Finish grade Metal grates Security fencing Sidewalks, stoops, and steps Steel guardrails, handrails, and stairs Trees and shrubs Vehicle bumper guards Wood guardrails, handrails, and stairs
	Exterior wall surfaces	Adobe unit masonry Brick masonry units Cementitious coating Concrete masonry and glass block unit Concrete surfaces Caulking Exterior ceramic tile Lintels and sills Metal cladding and metal panels Miscellaneous metals Signs, lettering, and attachments Terra cotta masonry Vinyl cladding Wood cladding
	Exterior windows and louvers	Aluminum windows Caulking Glass and glazing Metal clad wood windows Metal louvers and metal grilles Steel windows Vinyl clad wood windows Window hardware Window screens Wood windows

	Exterior doors	Aluminum and glass doors and frames Caulking Door hardware Glass in doors Louvers in doors Metal and steel doors and frames Metal coiling doors Screen doors Sectional overhead doors wood panel Steel and glass doors and frames Wood doors and frames
	Exterior decking	Brick masonry units Concrete masonry units Concrete surfaces Wood
	Exterior ceilings	Concrete ceilings Gypsum board ceilings
Interior Construction System	Interior walls	Ceramic tile Concrete masonry units Concrete walls Glass block masonry Gypsum plaster Gypsum wallboard Metal cladding and panels Portland cement plaster Structural glazed tile and brick Terra cotta unit masonry Vinyl, fabric, wallpaper Wood and plastic laminated paneling Wood paneling and wood surfaces
	Interior doors	Caulking Door hardware Glass in doors Hollow doors and frames: Steel and metal Louvers in doors Metal and glass doors and frames Wood doors and frames
	Interior floors and bases	Bases: Vinyl, metal, wood, and tiles Carpet Ceramic tile Concrete floors Resilient tile and flooring Terrazzo flooring Wood flooring

	Interior ceilings	Acoustical ceilings Concrete ceilings Exposed ceiling insulation Gypsum board and plaster ceilings Suspended metal ceilings
	Interior specialties	Casework Identifying devices, signs, etc. Metal grilles and screens Metal toilet partitions Metal wall louvers Toilet and bath accessories
	Interior windows	Aluminum windows Caulking Glass and glazing Metal clad wood windows Steel windows Vinyl clad wood windows Window hardware Wood windows
	Interior stairs	Concrete stairs Steel guardrails, handrails, and stairs Wood guardrails, handrails, and stairs
Plumbing System	General	General
Heating Systems	Equipment	Condensate pump and motor Condensate receiver Expansion tank Flash tank Hot water circulation pump and motor Pressure-reducing station Radiator Steam supply and return piping Steam to hot water converter
Cooling System	Air handler units	Central air handlers and ventilation equipment Fire dampers Laundry exhaust fans Mechanical room exhaust fan Power roof ventilators
	Refrigeration systems	Mechanical refrigeration equipment
Electrical System	Electrical equipment	Electrical equipment
	Electrical sump pump	Sump pumps and motors

Appendix B: Software Data Flow Diagrams

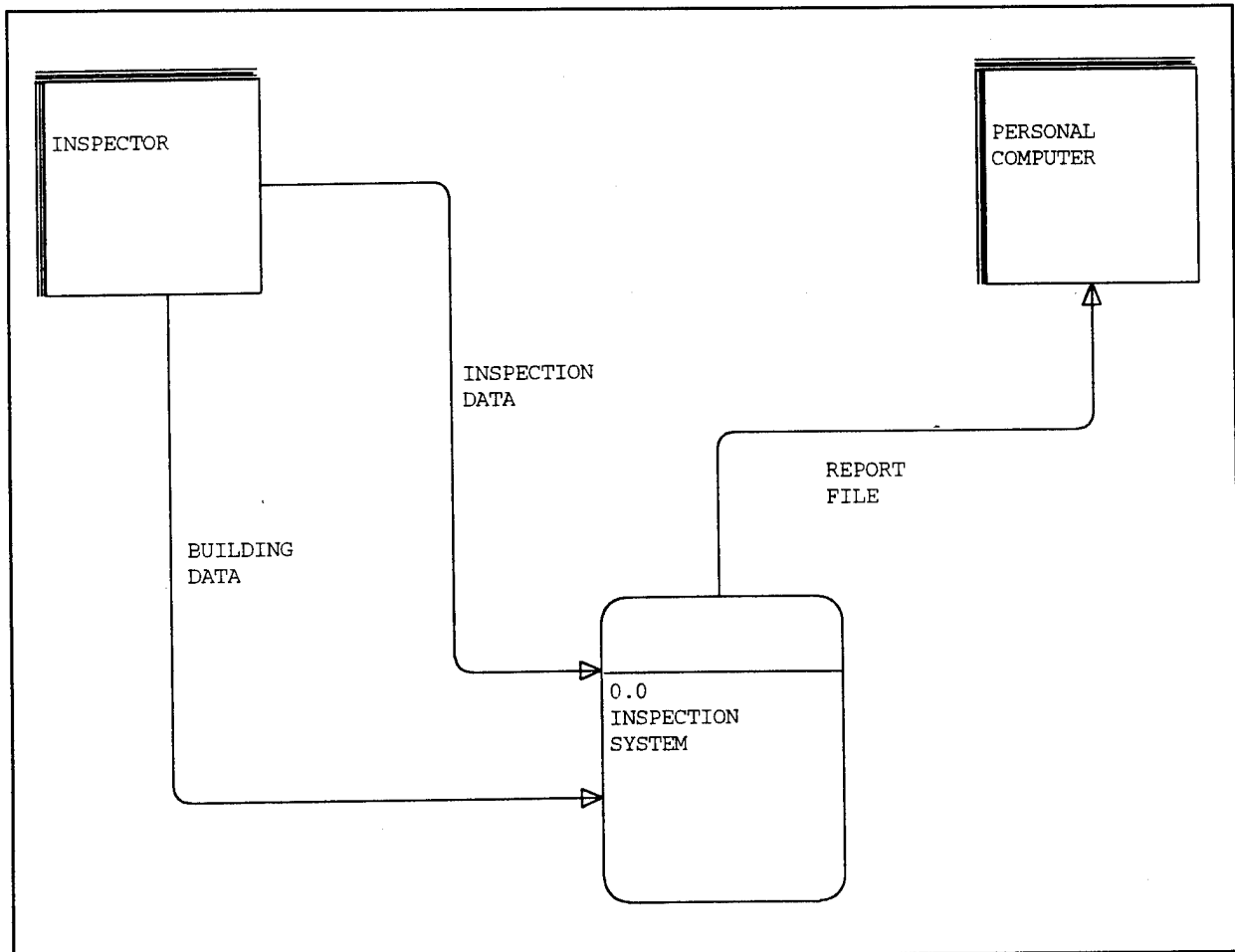

Figure B1. General flow of the layaway program.

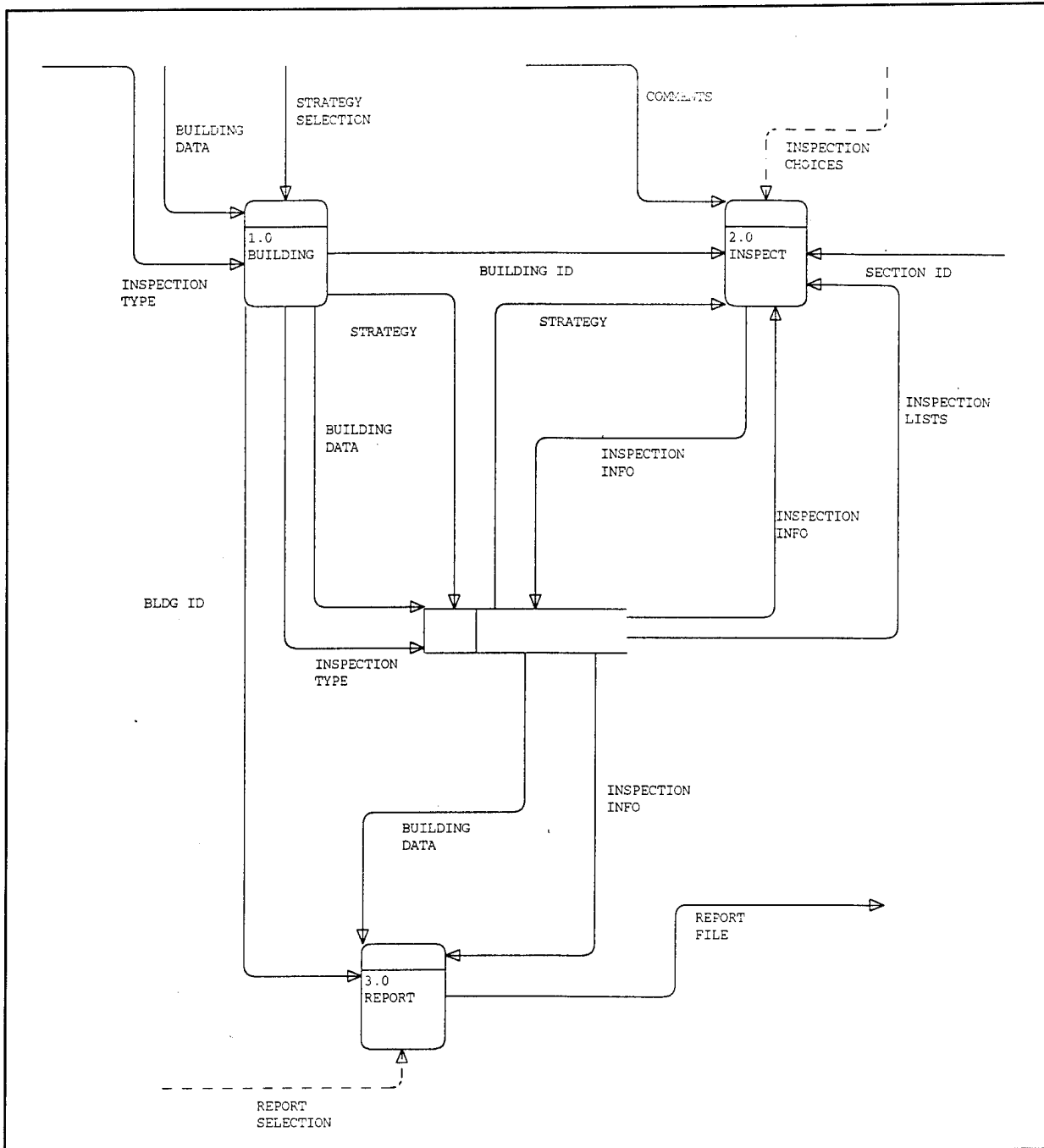

Figure B2. Flow of layaway program at inspection level.

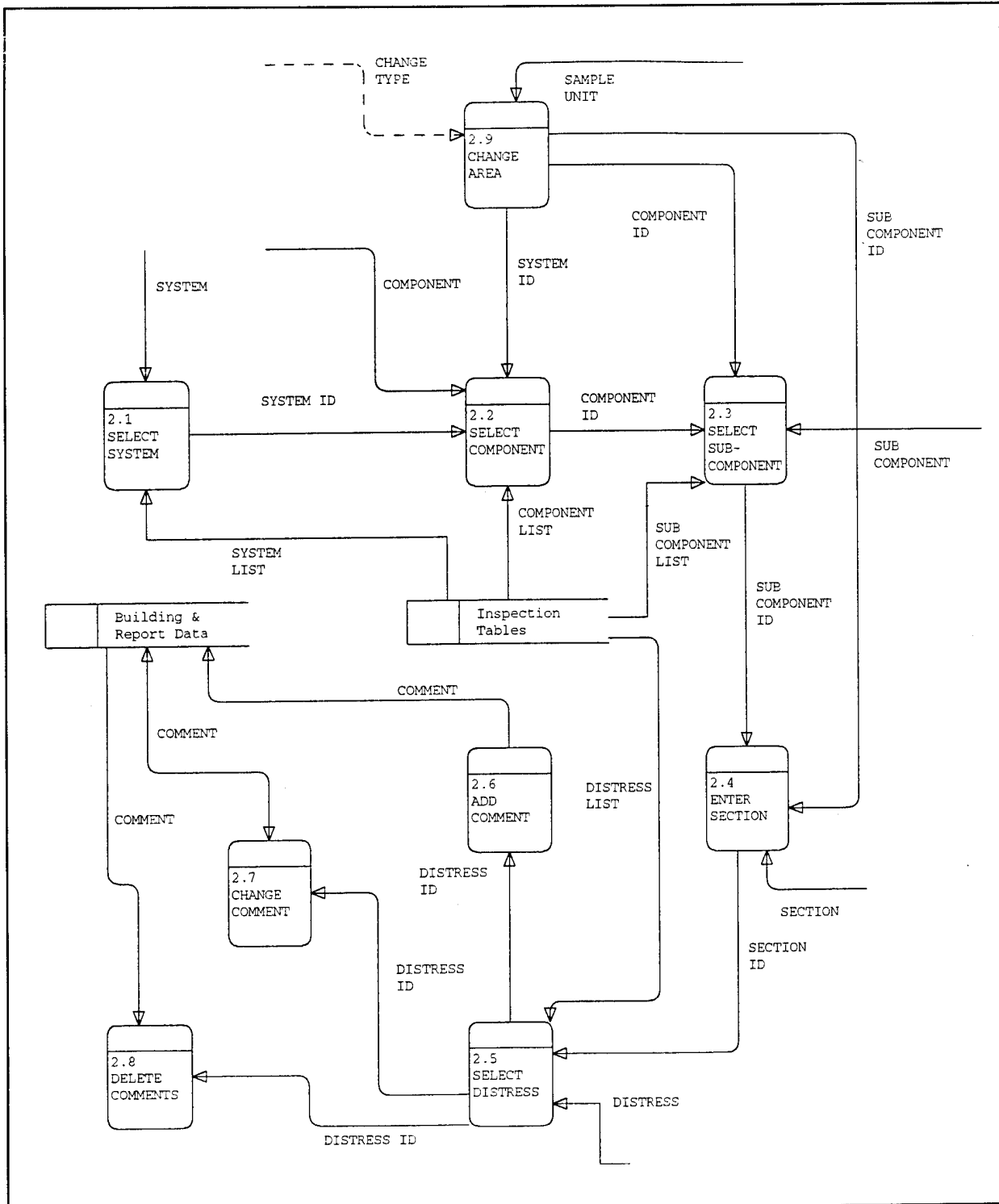

Figure B4. Flow of layaway program to inspect.

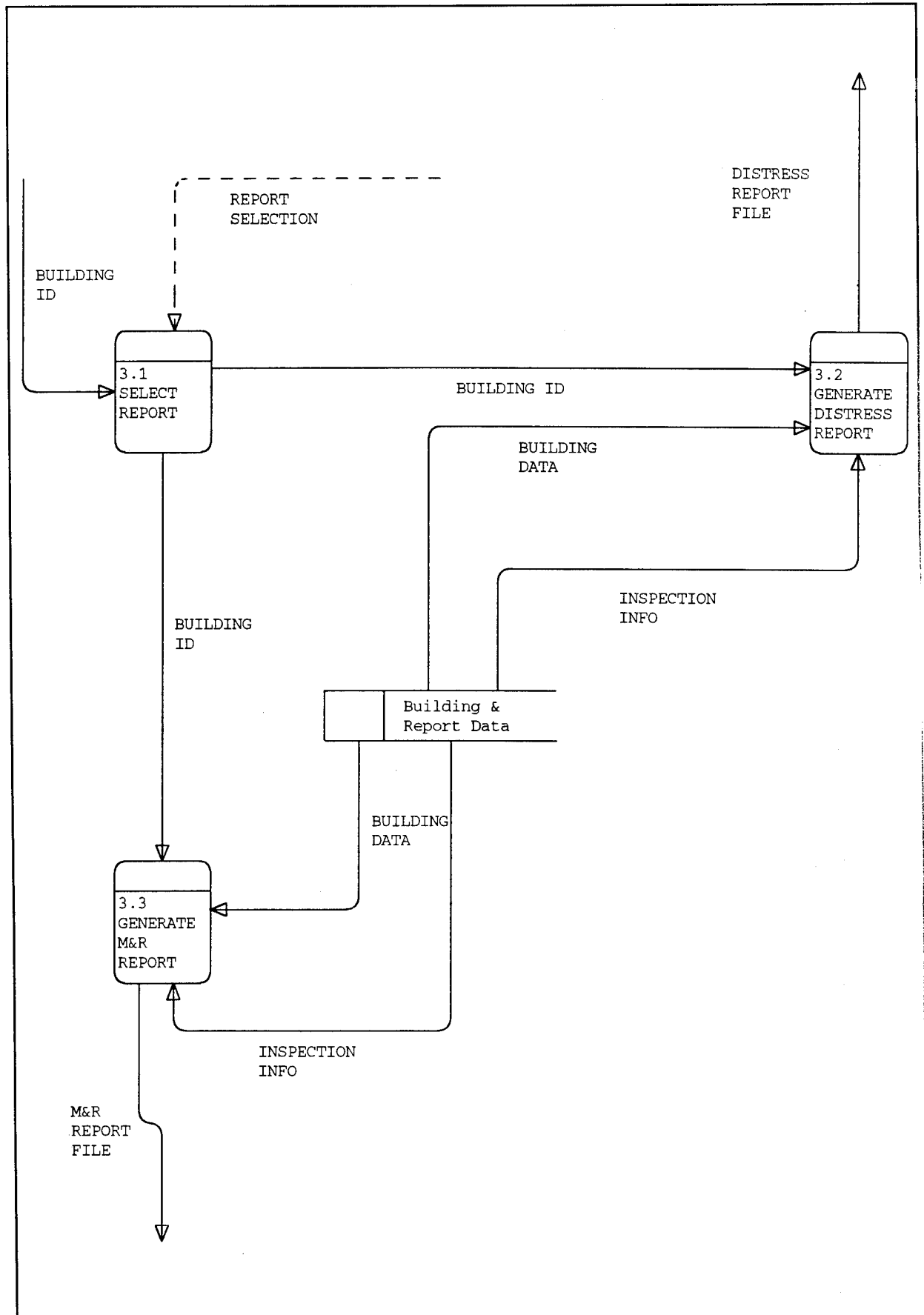

Figure B5. Flow of layaway program to generate a report.

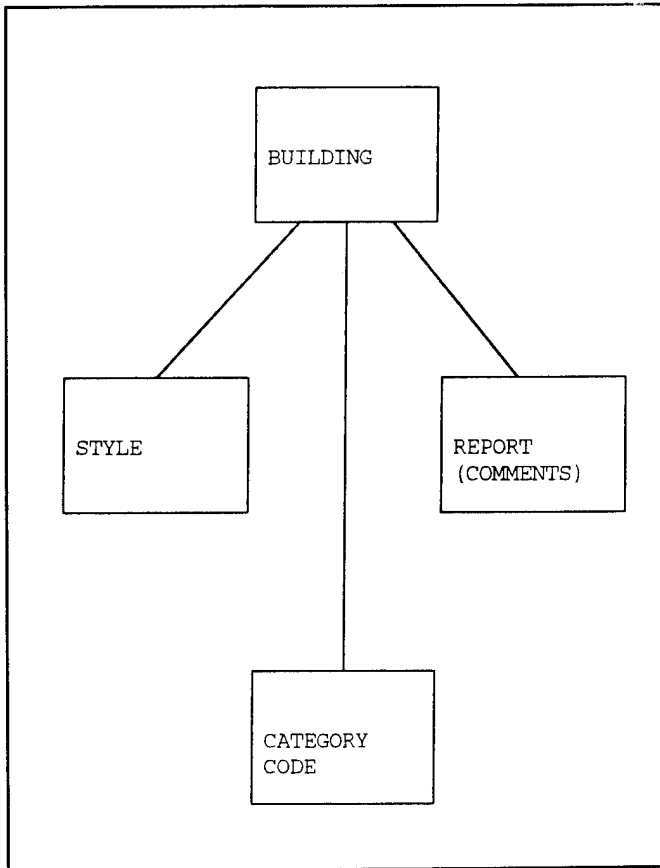

Figure B6. General data structure.

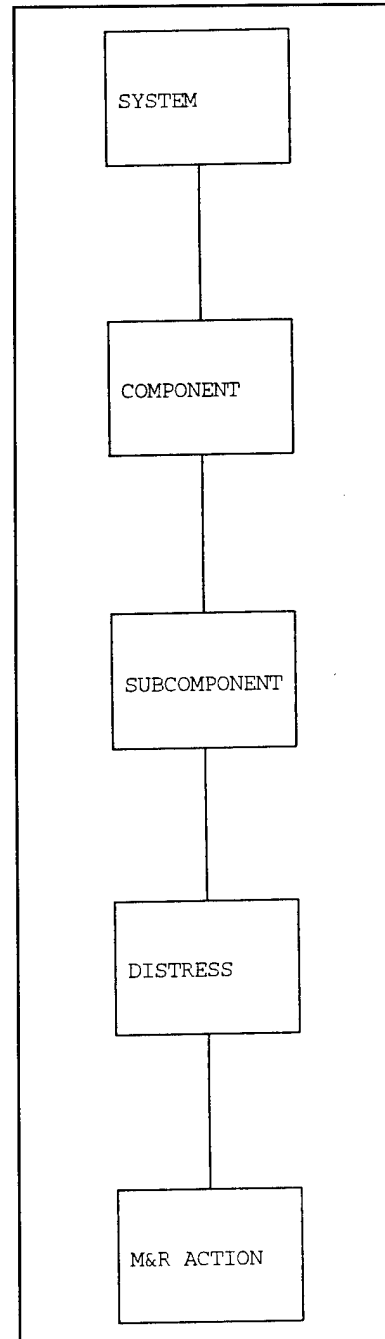

Figure B7. General building data structure.

Appendix C: Reports of Buildings at Fort Sheridan

Introduction

The 20 buildings used by USACERL for testing at Fort Sheridan are part of a National Historic Landmark. The buildings involved in the study are listed in Table C1.

The inspection conducted followed the guidelines outlined for the different building systems, components, and subcomponents from Volume II of Uzarski et al. (1991) and Hunter et al. (1992). Since each building report was quite detailed and lengthy, this report only shows a sample to give the reader an understanding of the reports.

Table C1. Surveyed buildings at Fort Sheridan.

BLDG #	Type of Building
4	Family Housing
9	Family Housing
12	Family Housing
23A	Family Housing
23B	Family Housing
32	Jail
33	Administrative
48	Administrative
49	Administrative
51	Administrative
52	Administrative
91A	Family Housing
91B	Family Housing
92A	Family Housing
92B	Family Housing
104	Family Housing
110	Other
115	Other
127	Other
128	Warehouse

Report 1: Building #4

U.S. Army Corps of Engineers
Construction Engineering Research Laboratories

Building Name: FAMILY HOUSING UNIT #4

Building Id: 4

Address:

Zone:

Square Feet:

Number of Stories: 2

Year Built:

Construction Code:

Building POC Name:

Building POC Phone:

Category Code:

Category Description:

Architect\Drawing:

Style:

Inspection Type: Deactivate

Strategy: Less than 1 Year

Description:

Report 1: Building #4 (Cont.)

Maintenance and Repair Report

Building ID: 4

System: Interior Construction

Component: Bases: Vinyl, Metal, Wood and Tiles

Subcomponent: Interior Floors and Bases

Distress: Staining & discoloration

Quantity: 4 Unit of Measure: sf

Comment: THERE IS A KOOLAID STAIN IN THE KITCHEN WOOD BASES ON THE NORTH WALL

Maintenance & Repair Action: Clean off surface stains and discoloration

Maintenance and Repair Report

Building ID: 4

System: Interior Construction

Component: Wood Flooring

Subcomponent: Floors and Bases

Distress: Staining & discoloration

Quantity: 4 Unit of Measure: FT

Comment: THERE IS A KOOLAID STAIN IN THE KITCHEN WOOD BASES ON THE NORTH WALL

Maintenance & Repair Action: Clean off surface stains and discoloration

Report 1: Building #4 (Cont.)

Maintenance and Repair Report

Building ID: 4

System: Interior Construction

Component: Ceramic Tiles

Subcomponent: Interior Floors and Bases

Distress: Chipped Ceramic Tiles

Quantity: 4 Unit of Measure: SF

Comment: CERAMIC TILES IN THE MASTER BATHROOM SHOWER ARE CHIPPED BADLY AND WILL NEED TO BE REPLACED.

Maintenance & Repair Action: Replace/repair chipped units

Maintenance and Repair Report

Building ID: 4

System: Interior Construction

Component: Wood Flooring

Subcomponent: Interior Floors and Bases

Distress: Rot

Quantity: 30 Unit of Measure: FT

Comment: THERE ARE 30 SQ FT IN WHICH THE TILES ARE ROTTING.

Maintenance & Repair Action: Replace broken, missing, or rotted sections

Report 1: Building #4 (Cont.)

Maintenance and Repair Report

Building ID: 4

System: Roofing System

Component: Gutters and Downspout

Subcomponent: Roof Drainage

Distress: Secured to building.

Quantity: 10 Unit of Measure: lf

Comment: THERE IS 10 LF ON THE NORTH SIDE OF THE BUILDING THAT
NEEDS SECURED

Maintenance & Repair Action: Secure gutter and downspout to
building.

Report 2: Building #110

U.S. Army Corps of Engineers

Construction Engineering Research Laboratories

Building: #110

Building ID: 110

Address:

Zone:

Square Feet:

Number of Stories: 1

Year Built:

Construction Code:

Building POC Name:

Building POC Phone:

Category Code:

Category Description:

Architect\Drawing:

Style:

Inspection Type: Deactivate

Strategy: Less than 1 Year

Description:

Report 2: Building #110 (CONT.)

Maintenance and Repair Report

Building ID: 110

System: Roofing

Component: Debris and Vegetation

Subcomponent: Shingles

Distress: Foreign objects on roof or gutters.

Quantity: Unit of Measure:

Comment: THERE ARE LEAVES AND BRANCHES ON THE SHINGLES.

Maintenance & Repair Action: Eliminate Foreign Objects

Maintenance and Repair Report

Building ID: 110

System: Roofing

Component: Shingles

Subcomponent: Breakage/Damage

Distress: Broken or Missing Shingles

Quantity: Unit of Measure:

Comment: needs 2 shingles for every five sq ft.

Maintenance and Repair Action: Replace Missing or Broken Shingles

Report 2: Building #110 (CONT.)

Maintenance and Repair Report

Building ID: 110

System: Exterior Closure

Component: Window and Louvers

Subcomponent: Metal Louvers and Metal Grills

Distress: Rust

Quantity: Unit of Measure:

Comment: the bars on the window are rusting badly.

Maintenance and Repair Action: Scrape and Coat

Report 3: Building #127

U.S. Army Corps of Engineers

Construction Engineering Research Laboratories

Building: #127

Building ID: 127

Address:

Zone:

Square Feet:

Number of Stories:

Year Built:

Construction Code:

Building POC Name:

Building POC Phone:

Category Code:

Category Description:

Architect\Drawing:

Style:

Inspection Type: Deactivate

Strategy: Less than 1 Year

Description:

Report 3: Building #127 (CONT.)

Maintenance and Repair Report

Building ID: 127

System: Exterior Closure

Component: Trees and Shrubs

Subcomponent: Exterior Perimeter

Distress: Building contact by trees, branches, shrubs, or vegetative growth.

Quantity:

Unit of Measure:

Comment: WEEDS AND GRASSES AROUND THE BUILDING NEED TO BE CUT AND MAINTAINED.

Maintenance & Repair Action: Remove or trim all tree, shrub, and vegetative growth in contact with building.

Maintenance and Repair Report

Building ID: 127

System: Roofing

Component: Shingles

Subcomponent: Breakage/Damage

Distress: Broken or Missing Shingles

Quantity: 2 Unit of Measure: every 10 sq ft.

Comment: 2 new shingles are need every 10 sq ft.

Maintenance and Repair Action: Replace broken or missing shingles

Report 3: Building #127 (CONT.)

Maintenance and Repair Report

Building ID: 127

System: Exterior Closure

Component: Exterior Wall Surface

Subcomponent: Concrete Surfaces

Distress: Deficit Paint

Quantity: 200 Unit of Measure: sf

Comment: Needs Paint on one side

Appendix D: Reports of Buildings at Fort Ord

Introduction

The 35 buildings that USACERL tested at Fort Ord are eligible to be part of the National Register. The buildings involved in the study are listed in Table D1.

The inspection conducted followed the guidelines outlined for the different building systems, components, and subcomponents from Volume II of Uzarski et al. (1991) and Hunter et al. (1992). Since each building report was quite detailed and lengthy, this report shows only a sample of the building reports to give the reader an understanding of the reports.

Table D1. Surveyed buildings at Fort Ord.

BLDG #	Type of Building
1 (Stillwell Hall)	Administrative
12	Administrative
13	Administrative
14	Administrative
16	Administrative
17	Administrative
27	Administrative
29	Administrative
30	Administrative
33	Administrative
34	Administrative
35	Administrative
36	Administrative
37	Administrative
38	Administrative
74	Administrative
75	Administrative
76	Administrative

77	Administrative
78	Administrative
79	Administrative
80	Administrative
81	Administrative
82	Administrative
83	Administrative
91	Administrative
110	Administrative
111	Administrative
112	Administrative
113	Administrative
115	Administrative
116	Administrative
117	Administrative
118	Administrative
124	Administrative

Report 1: Building #1 (Stillwell Hall)

U.S. Army Corps of Engineers
Construction Engineering Research Laboratories

Building Name: STILLWELL HALL

Building Id: 1

Address:

Zone:

Square Feet:

Number of Stories: 2

Year Built:

Construction Code:

Building POC Name:

Building POC Phone:

Category Code:

Category Description:

Architect/Drawing:

Style: Spanish Colonial Revival

Inspection Type: Deactivate

Strategy: Less than 1 Year

Description:

Report 1: Building #1 (Stillwell Hall) (CONT.)

Maintenance and Repair Report

Building ID: 1

System: Exterior Closure

Component: Brick Masonry Units

Subcomponent: Exterior Wall

Distress: Broken or missing units

Quantity: 1 Unit of Measure: Stone

Comment: THE HAND RAIL ON THE DECK HAS STONES COMING OFF.

Maintenance & Repair Action: Replace broken or missing units

Maintenance and Repair Report

Building ID: 1

System: Exterior Closure

Component: Metal and Steel Doors and Frames

Subcomponent: Exterior Doors

Distress:

Quantity: 3 Unit of Measure:

Comment: Three doors have rust that makes them stick.

Maintenance & Repair Action: Repair or replace doors.

Report 1: Building #1 (Stillwell Hall) (CONT.)

Maintenance and Repair Report

Building ID: 1

System: Exterior Closure

Component: Concrete Surfaces

Subcomponent: Exterior Surfaces

Distress: Cracks & holes.

Quantity: 100 Unit of Measure: SQ FT

Comment: THE WALL BEHIND THE BUILDING HAS ABOUT 100 SQ FT OF CRACKS THAT IS WARPING QUICKLY—WILL NEED REPAIR SOON.

Maintenance & Repair Action: Repair cracks & holes.

Maintenance and Repair Report

Building ID: 1

System: Exterior Closure

Component: Concrete Surfaces

Subcomponent: Exterior Wall Surfaces

Efflorescence; locate source of water penetration.

Quantity: 24 Unit of Measure:

Comment: THE LEFT SIDE OF THE BUILDING HAS A 24 SQ FT BRICK WALL THAT NEVER SEEMS TO DRY OUT.

Maintenance & Repair Action: Clean off efflorescence.

Report 1: Building #1 (Stillwell Hall) (CONT.)

Maintenance and Repair Report

Building ID: 1

System: Exterior Closure

Component: Exterior Ceramic Tile

Subcomponent: Exterior Wall Surfaces

Distress: Loose, broken or missing tiles.

Quantity: 5 Unit of Measure:

Comment: THE TILE OUTSIDE THE FRONT OF THE BUILDING HAS A TILE SEATING AREA THAT DOESN'T LOOK GOOD.

Maintenance & Repair Action: Groove-in loose tiles. Replace broken or missing tiles.

Maintenance and Repair Report

Building ID: 1

System: Interior Construction

Component: Acoustical Ceilings

Subcomponent: Interior Ceilings

Distress: Staining & discoloration

Quantity: 10 Unit of Measure:

Comment: MANY CEILINGS ARE DAMAGED BY WATER THAT LEAKS THROUGH THE ROOF.

Maintenance & Repair Action: Clean off surface

Report 1: Building #1 (Stillwell Hall) (CONT.)

Maintenance and Repair Report

Building ID: 1

System: Interior Construction

Component: Acoustical Ceilings

Subcomponent: Interior Ceilings

Distress: Corroded or damaged trim

Quantity: Unit of Measure:

Comment: DURING THE REPLACEMENT OF CEILINGS CHECKING THE METAL FOR CORROSION WOULD BE ADVISED.

Maintenance & Repair Action: Remove corrosion from trim and paint

Maintenance and Repair Report

Building ID: 1

System: Interior Construction

Component: Acoustical Ceilings

Subcomponent: Interior Ceilings

Distress: Moisture damage

Quantity: 20 Unit of Measure: sf

Comment:

Maintenance & Repair Action: Replace damaged sections

Report 1: Building #1 (Stillwell Hall) (CONT.)

Maintenance and Repair Report

Building ID: 1

System: Interior Construction

Component: Acoustical Ceilings

Subcomponent: Interior Ceilings

Distress: Locate source of moisture penetration

Quantity: 10 Unit of Measure: sf

Comment: THE PROBLEM IS A LEAKING ROOF THAT SOAKS THE PLASTER AND LOOSEN THE BOARDS THAT CAUSES THEM TO FALL.

Maintenance & Repair Action: Eliminate moisture penetration

Maintenance and Repair Report

Building ID: 1

System: Interior Construction

Component: Gypsum Board and Plaster Ceilings

Subcomponent: Interior Ceilings

Distress: Staining & discoloration

Quantity: Unit of Measure:

Comment: MANY PARTS OF THE BUILDING HAVE STAINING AND DISCOLORED CEILINGS.

Maintenance & Repair Action: Clean off surface stains and discoloration

Report 1: Building #1 (Stillwell Hall) (CONT.)

Maintenance and Repair Report

Building ID: 1

System: Interior Construction

Component: Gypsum Board and Plaster Ceilings

Subcomponent: Interior Ceilings

Distress: Sagging

Quantity: 50 Unit of Measure: LF

Comment: DUE TO LEAKING MANY BOARDS ARE SAGGING AND FALLING TO THE GROUND.

Maintenance & Repair Action: Replace sagging sections

Maintenance and Repair Report

Building ID: 1

System: Interior Construction

Component: Gypsum Board and Plaster Ceilings

Subcomponent: Interior Ceilings

Distress: Locate source of moisture penetration

Quantity: Unit of Measure:

Comment: MANY PARTS OF THE ROOF ARE LEAKING DUE TO LACK OF SHINGLES OR BROKEN SHINGLES.

Maintenance & Repair Action: Eliminate moisture penetration

Report 1: Building #1 (Stillwell Hall) (CONT.)

Maintenance and Repair Report

Building ID: 1

System: Interior Construction

Component: Hollow Doors and Frames: Steel and Metal

Subcomponent: Interior Doors

Distress: Surface coat damage

Quantity: Unit of Measure:

Comment: MOST DOORS IN THE HALL NEED A FRESH COAT OF PAINT AND SOME NEED SANDING.

Maintenance & Repair Action: Prepare AND refinish surface

Maintenance and Repair Report

Building ID: 1

System: Interior Construction

Component: Bases: Vinyl, Metal, Wood and Tiles

Subcomponent: Interior Floors and Bases

Distress: Staining & discoloration

Quantity: Unit of Measure:

Comment: NONE OF THE ABOVE I JUST WANT TO SAY THAT THE WOOD BASES ARE CHIPPED AND THE VINYL BASES HANGING AWAY FROM THE WALL WILL BE A TRIPPING HAZARD.

Maintenance & Repair Action: Clean off surface stains and discoloration

Report 1: Building #1 (Stillwell Hall) (CONT.)

Maintenance and Repair Report

Building ID: 1

System: Interior Construction

Component: Carpet Interior

Subcomponent: Floors and Bases

Distress: Dampness; rot

Quantity: 1 Unit of Measure: 9 FT

Comment: THE CARPET HAS MASKING TAPE THAT WILL CAUSE MOISTURE BUILDUP AND CAUSE THE CARPET TO ROT.

Maintenance & Repair Action: Remove damp, rotten sections & replace.

Maintenance and Repair Report

Building ID: 1

System: Interior Construction

Component: Ceramic Tiles

Subcomponent: Interior Floors and Bases

Distress: Locate source of moisture penetration

Quantity: Unit of Measure:

Comment: THE CERAMIC TILES ARE CHIPPED BADLY AND WILL NEED TO BE REPLACED.

Maintenance & Repair Action: Eliminate moisture penetrations

Report 1: Building #1 (Stillwell Hall) (CONT.)

Maintenance and Repair Report

Building ID: 1

System: Interior Construction

Component: Wood Flooring

Subcomponent: Interior Floors and Bases

Distress: Rot

Quantity: 30 Unit of Measure: FT

Comment: THERE ARE 30 SQ FT IN WHICH THE TILES ARE ROTTING.

Maintenance & Repair Action: Replace broken, missing, or rotted sections

Maintenance and Repair Report

Building ID: 1

System: Interior Construction

Component: Flooring

Subcomponent: Wood Interior floors & bases

Distress: Locate source of moisture penetration

Quantity: 100 TILES

Comment: There are over 100 tiles in the ballroom which are damaged by water from the ceiling.

Maintenance & Repair Action: Eliminate moisture penetrations

Report 1: Building #1 (Stillwell Hall) (CONT.)

Maintenance and Repair Report

Building ID: 1

System: Interior Construction

Component: Gypsum Plaster

Subcomponent: Interior Walls

Distress: Staining & discoloration & mildew

Quantity: 90 Unit of Measure: FT

Comment: DUE TO MOISTURE FROM CEILING AND WALL THE PLASTER IS ROTTING AND GETTING RUINED. IT IS HURTING THE WINDOW TOO.

Maintenance & Repair Action: Clean off surface stains and discoloration & mildew.

Maintenance and Repair Report

Building ID: 1

System: Interior Construction

Component: Gypsum Plaster

Subcomponent: Interior Walls

Distress: Locate source of moisture penetration

Quantity: Unit of Measure:

Comment: THE LOCATION OF MOISTURE IS FROM CRACKS IN THE WALL AND THE SHINGLES ARE NOT KEEPING THE WATER OUT

Maintenance & Repair Action: Eliminate moisture penetration

Report 1: Building #1 (Stillwell Hall) (CONT.)

Maintenance and Repair Report

Building ID: 1

System: Interior Construction

Component: Wood Windows

Subcomponent: Interior Windows

Distress: Broken or missing sections

Quantity: Unit of Measure:

Comment:

Maintenance & Repair Action: Replace broken or missing sections

Maintenance and Repair Report

Building ID: 1

System: Roofing System

Component: Gutters and Downspout

Subcomponent: Roof Drainage

Distress: Secured to building.

Quantity: Unit of Measure:

Comment: MOST OF THE GUTTERS AND DOWNSPOUT ARE RUSTED THROUGH AND WILL FALL OFF.

Maintenance & Repair Action: Secure gutter and downspout to building.

Report 1: Building #1 (Stillwell Hall) (CONT.)

Maintenance and Repair Report

Building ID: 1

System: Roofing System

Component: Gutters and Downspout

Subcomponent: Roof Drainage

Distress: Corrosion.

Quantity: Unit of Measure:

Comment: GUTTER WILL NEED TO BE REPLACED DUE TO SEVERE RUST.
DOWNSPOUT ALSO NEEDS TO BE REPAIRED.

Maintenance & Repair Action: Remove corrosion.

Maintenance and Repair Report

Building ID: 1

System: Roofing System

Component: Gutters and Downspout

Subcomponent: Roof Drainage

Distress: Broken or missing sections & fasteners.

Quantity: Unit of Measure:

Comment: THERE ARE MANY GUTTERS AND DOWNSPOUT WITHOUT SECTIONS
AND FASTENERS DUE TO RUST.

Maintenance & Repair Action: Replace broken gutters and downspout.

Report 2: Building #111

U.S. Army Corps of Engineers

Construction Engineering Research Laboratories

Building: FORT ORD #111

Building ID: 111

Address:Zone:

Square Feet:

Number of Stories:

Year Built:

Construction Code:

Building POC Name:

Building POC Phone:

Category Code:

Category Description:

Architect\Drawing:

Style:

Inspection Type: Deactivate

Strategy: Less than 1 Year

Description:

Report 2: Building #111 (CONT.)

Maintenance and Repair Report

Building ID: 111

System: Roofing

Component: Debris and Vegetation

Subcomponent: Shingles

Distress: Foreign objects on roof or gutters.

Quantity: Unit of Measure:

Comment: THERE ARE BIRD FECES AND MOSSES ON THE SHINGLES.

Maintenance & Repair Action: Eliminate Foreign Objects

Maintenance and Repair Report

Building ID: 111

System: Roofing

Component: Shingles

Subcomponent: Breakage/Damage

Distress: Broken or Missing Shingles

Quantity: Unit of Measure:

Comment: needs 2 shingles for every five sq ft.

Maintenance and Repair Action: Replace Missing or Broken Shingles

Report 2: Building #111 (CONT.)

Maintenance and Repair Report

Building ID: 111

System: Exterior Closure

Component: Window and Louvers

Subcomponent: Metal Louvers and Metal Grills

Distress: Rust

Quantity: Unit of Measure:

Comment: the bars on the window are rusting badly.

Maintenance and Repair Action: Scrape and Coat

Report 3: Building #77

U.S. Army Corps of Engineers

Construction Engineering Research Laboratories

Building: FORT ORD #77

Building ID: 77

Address:

Zone:

Square Feet:

Number of Stories:

Year Built:

Construction Code:

Building POC Name:

Building POC Phone:

Category Code:

Category Description:

Architect\Drawing:

Style:

Inspection Type: Deactivate

Strategy: Less than 1 Year

Description:

Report 3: Building #77 (CONT.)

Maintenance and Repair Report

Building ID: 77

System: Exterior Closure

Component: Concrete Surfaces

Subcomponent: Exterior Wall Surfaces

Distress: Cracks & holes.

Quantity: Unit of Measure:

Comment: WALL HAVE CRACKS IN SEVERAL PLACES

Maintenance and Repair Action: Repair cracks & holes.

Maintenance and Repair Report

Building ID: 77

System: Roofing

Component: Shingles

Subcomponent: Breakage/Damage

Distress: Broken or Missing Shingles

Quantity: 2 Unit of Measure: every 10 sq ft.

Comment: 2 new shingles are needed every 10 sq ft.

Maintenance and Repair Action: Replace broken or missing shingles

Report 3: Building #77 (CONT.)

Maintenance and Repair Report

Building ID: 77

System: Exterior Closure

Component: Exterior Wall Surface

Subcomponent: Concrete Surfaces

Distress: Deficit Paint

Quantity: Unit of Measure:

Comment: Needs Paint on one side

Maintenance and Repair Action: Scrape Wall and Paint

Appendix E: Program Database Characteristics

Databases in Program:

CCHI.DBF	STYLE.DBF
CLOW.DBF	SUBCOMP.DBF
COMPON.DBF	SYS.DBF
DISTDB.DBF	

Configuration of CCHI.DBF

Num.	Fieldname	Field Type	Field Len	Decimal Place
1	CAT CD3	Character	3	
2	CAT DESC1	Character	45	

Configuration of CLOW.DBF

Num.	Fieldname	Field Type	Field Len	Decimal Place
1	CAT CD3	Character	3	
2	CAT CD2	Character	2	
3	CAT DESC2	Character	45	

Configuration of COMPON.DBF

Num.	Fieldname	Field Type	Field Len	Decimal Place
1	COMP	Character	29	
2	COMP INDX	Numeric	2	0
3	COMP INDC	Numeric	2	0

Configuration of DISTDB.DBF

Num.	Fieldname	Field Type	Field Len	Decimal Place
1	SYS NAME	Character	28	
2	COMP NAME	Character	29	
3	SUB NAME	Character	33	
4	DIST	Character	240	
5	MR ACTION	Character	240	
6	DIST INDX	Numeric	4	0
7	DIST INDC	Numeric	2	0
8	SYS NUM	Numeric	2	0
9	COMP NUM	Numeric	2	0
10	SUB NUM	Numeric	2	0
11	PERIODIC	Logical	1	
12	DEACTIVATE	Logical	1	
13	REACTIVATE	Logical	1	
14	PLT30D	Logical	1	
15	PLT1YR	Logical	1	
16	PGT1YR	Logical	1	
17	DLT30D	Logical	1	
18	DLT1YR	Logical	1	
19	DGT1YR	Logical	1	
20	RLT30D	Logical	1	
21	RLT1YR	Logical	1	
22	RGT1YR	Logical	1	
23	GEN INSP	Logical	1	
24		Character	240	

Configuration of STYLE.DBF

Num.	Fieldname	Field Type	Field Len	Decimal Place
1	STYLE	Character	30	

Configuration of SUCOMP.DBF

Num.	Fieldname	Field Type	Field Len	Decimal Place
1	SUB	Character	33	
2	SUB INDX	Numeric	2	0
3	SUB INDC	Numeric	2	0

Configuration of SYS.DBF

Num.	Fieldname	Field Type	Field Len	Decimal Place
1	SYS	Character	28	

Acronyms

AR	Army Regulation
AIS	Advanced Information Services, Inc.
BRAC	Base Realignment and Closure
CFR	Code of Federal Regulations
DPW	Directorate of Public Works
FORSCOM	U.S. Army Forces Command
HVAC	heating, ventilating, and air conditioning
MACOM	Major Army Command
M&R	maintenance and repair
MOA	memorandum of agreement
NHPA	National Historic Preservation Act
NCO	noncommissioned officer
SHPO	State Historical Preservation Officer
TN	Technical Note
USACPW	U.S. Army Center for Public Works
USACERL	U.S. Army Construction Engineering Research Laboratories

DISTRIBUTION

Chief of Engineers

ATTN: CEHEC-IM-LH (2)

ATTN: CEHEC-IM-LP (2)

ATTN: CERD-L

ATTN: CECC-R

HQDA

ATTN: DAIM-BO

ATTN: DAIM-ED-N

CECPW

ATTN: CECPW-ES

Fort Chaffee 72905

ATTN: Deputy Installation Mgr.

Fort Devens 04133

ATTN: BRAC Mgr.

Harry Diamond Lab 20783

ATTN: AMSRL-WT-NW

ATTN: BRAC Chief

Fort Dix 08640

ATTN: Base Realignment Office

Fort Benjamin Harrison 46216

ATTN: ATZI-CS (BRACO)

Fort Ord 93941

ATTN: AFZW-DBRAC

Sacramento Army Depot 95813

Fort Detrick 21702

ATTN: HSHD-EHE

Vint Hill Farms 22186

ATTN: SELVH-BRAC

Letterkenny Army Depot 17201

ATTN: SDSLE-I

Presidio of San Francisco 94129

ATTN: Director of Public Works

Tooele Army Depot 84074

ATTN: SDSTE-DCBO-BMD (2)

Defense Technical Info Center 22304

ATTN: DTIC-FAB (2)

25

02/94