

D 442062

NASA
Technical
Paper
2826

July 1988

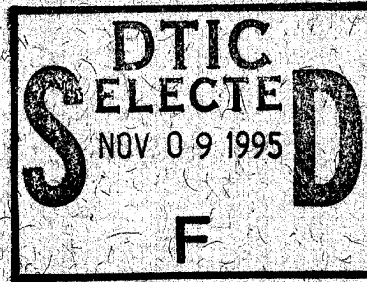

Properties of Two Composite
Materials Made of
Toughened Epoxy Resin and
High-Strain Graphite Fiber

Marvin B. Dow
and Donald L. Smith

DISTRIBUTION STATEMENT A
Approved for public release
Distribution Unlimited

OK

DTIC QUALITY INSPECTED 6

19951024 087

NASA

PLASTEC
052004

**NASA
Technical
Paper
2826**

1988

Properties of Two Composite
Materials Made of
Toughened Epoxy Resin and
High-Strain Graphite Fiber

Marvin B. Dow
*Langley Research Center
Hampton, Virginia*

Donald L. Smith
*Planning Research Corporation
Hampton, Virginia*

Accession For	
NTIS	<input checked="" type="checkbox"/>
CRA&I	<input type="checkbox"/>
DTIC	<input type="checkbox"/>
TAB	<input type="checkbox"/>
Unannounced	<input type="checkbox"/>
Justification	
By <i>DTIC-AL memo</i>	
Distribution / <i>11-2-95</i>	
Availability Codes	
Dist	Avail and/or Special
<i>A-1</i>	

The use of trademarks or names of manufacturers in this report is for accurate reporting and does not constitute an official endorsement, either expressed or implied, of such products or manufacturers by the National Aeronautics and Space Administration.

Introduction

Brittle behavior of graphite-epoxy materials remains a major barrier to expanding their applications in aircraft structures. Holes, notches, or induced damage severely degrade the structural efficiency of these materials, particularly their compression properties. As a result, the design of composite structures must assume very conservative performance limits. A long-recognized need continues for composite materials that tolerate damage and resist delaminations.

In response to this need, development efforts are focused on toughened epoxies, thermoplastics, and high-strain fibers (refs. 1, 2, and 3). Two new toughened epoxy matrix materials bear the commercial designations 8551-7 and 1808I. Developed specifically for improved damage tolerance, the two resin materials differ fundamentally in the approach to achieving toughness. Composite materials incorporating these resins and high-strain fibers offer substantially better structural performance than earlier graphite-epoxy materials.

This paper presents results from an experimental evaluation of IM7/8551-7 and IM6/1808I. Data include ply level strengths and moduli, notched tension and compression strengths, and compression-after-impact assessments. The purpose was to (1) compile tension and compression properties useful in preliminary design and (2) make a limited comparison of these materials with other graphite-epoxy systems. Specimen fabrication and testing were performed at the NASA Langley Research Center.

Materials

The graphite-epoxy materials evaluated in this investigation were obtained from Hercules, Incorporated (IM7/8551-7), and American Cyanamid Company (IM6/1808I). Composite prepreg characteristics included in the purchase specifications and material lot designations are shown in table 1. Both materials provide a compliant resin interface between fiber plies for improved impact and delamination resistance. Photomicrographs of cured laminates show the different approaches used in achieving the desired interface. The IM7/8551-7 material (figs. 1(a) and 1(b)) has small elastomeric particles within the epoxy matrix. Carbon coating the laminate surface provided better definition of the particles. These particles, being larger than the space between fibers, are predominantly constrained to the interply region. In contrast, the IM6/1808I is manufactured with a thin thermoplastic material film applied to one side of the prepreg tape. When cured, the laminate has an interleaf approximately 0.5 mil thick between fiber plies.

As shown in figure 2, the film does not diffuse into the epoxy matrix.

To produce laminates from prepreg tapes, standard bagging procedures (ref. 4) were used. Because of the thermoplastic film, the interleaved prepreg has tack on only one side and therefore requires special care in lay-up. The cure cycle (shown in fig. 3) recommended by both manufacturers is the "standard" cycle favored by users. For the relatively thick laminates (0.25 in.) of IM7/8551-7 material the standard cure cycle resulted in unacceptable porosity. After consultation with the manufacturer, the cure cycle was modified as shown in figure 4. The modified cure cycle produced sound laminates. Apparently, thick 8551-7 matrix laminates require more time for compaction than that provided by the standard cycle.

Test Specimens

Unidirectional and cross-ply (quasi-isotropic) laminates were machined into specimens for the test matrices shown in table 2. Specimen configurations are shown in figure 5. With the exception of the short-block compression specimen, a Langley Research Center configuration, the specimen configurations were similar to those recommended in references 4 and 5. Replicate specimens were tested in each configuration in order to obtain average values for various engineering properties. The strain gages were put on the specimens in accordance with the recommendations of references 4 and 5.

Test Procedures

Environmental Conditioning

For most tests, the specimens were at room temperature and contained moisture acquired during exposure to shop and laboratory environments. This condition is called room temperature, dry (RTD) in table 2 and elsewhere. Selected specimens were tested in a cold (-65°F) and dry condition by enclosing the specimen in a cold chamber. Other specimens were tested in a wet condition at either room temperature (RTW) or 180°F . A heating chamber attached to the test machine was used for hot tests.

Wet specimens were conditioned by immersion for 45 days in water at 160°F . Compression-after-impact specimens were immersed after the impact event. Absolute moisture levels in test specimens were not measured. Ancillary coupons, cut from thick (0.25 in.) plates, were immersed for 45 days and then dried to remove all moisture. Weight measurements indicated absolute moisture levels of 0.8 and 0.5 percent in the IM7/8551-7 and IM6/1808I materials, respectively. At these levels, probably neither material reached full saturation from the 45-day

immersion. Wet test specimens had strain gages applied after removal from the water and were tested in an expeditious manner (usually in less than 1 hr).

Ply Level Tension, Compression, and Shear Tests

The 0° tension tests used tabbed specimens (fig. 5(a)) pulled in a 55-kip hydraulic test machine equipped with hydraulic-pressure-activated grips. The machine applied load at a displacement rate of 0.05 in/min, and specimen strains were recorded throughout loading. The same testing machine and procedures were used in tests of untabbed 90° and ±45° specimens (fig. 5(a)). For 0° compression tests, a short-block specimen (fig. 5(b)) was chosen because that configuration had been used for tests reported in reference 6. The short-block specimens, with ends ground flat and parallel, were tested in the fixture shown in figure 6. This fixture clamps the specimen ends to reduce "brooming." A 120-kip hydraulic machine applied load at 6 kips/min, and strains were recorded throughout the tests.

Notched Tension and Compression Tests

To assess the performance of IM7/8551-7 and IM6/1808I materials with notches, tension and compression tests were performed using specimens machined from quasi-isotropic laminates. Baseline tension and compression data were obtained from unnotched specimens. For unnotched compression tests, reference 4 recommends 10-in. by 3-in. specimens, but better results were obtained from short-block specimens (fig. 5(b)). Other specimen configurations for notched tension and compression tests are shown in figures 5(c), 5(d), and 5(e).

Compression-After-Impact Tests

Compression-after-impact tests were performed on quasi-isotropic laminates in accordance with the procedures outlined in references 4 and 5, but the panels were impacted by using an air gun apparatus rather than dropped weights. The low-velocity impact air gun apparatus, developed at the Langley Research Center, is shown in figure 7. The apparatus consists of a 0.50-in.-diameter gun barrel, service air (100 psi), pressure regulator, solenoid valve, light-emitting and light-sensitive diodes, power supply, and counter. The gun fires aluminum spheres with a mass of 0.0065 lb. A velocity of 443 ft/sec is required to achieve an impact energy of 20 ft-lb.

After the impact event, the test panels were ultrasonically inspected to measure the impact damage area. For compression testing, the panels were

mounted in the apparatus shown in figure 8. Compression load was applied at the rate of 8 kips/min, and strains were recorded throughout the tests.

Results and Discussion

Test data for individual specimens of the IM7/8551-7 and IM6/1808I materials are given in tables 3 through 11. The tables also show average values and standard deviations for the various data. In general, the data variability is small, indicative of high quality specimens and good test techniques. Typical stress-strain curves are shown in figures 9 and 10. Figures 11 through 16 show average property values for the various specimen configurations. Also, for comparison purposes, these figures show values for two other graphite-epoxy materials: HSC/1806 (unpublished data supplied by Lockheed Corporation) and T300/5208 (data from ref. 7). The HSC/1806 material combines high-strain Celion fibers with a toughened epoxy matrix resin manufactured by American Cyanamid Company. The T300/5208 material, consisting of low-strain Toray fibers and an epoxy matrix resin manufactured by Narmco Corporation, has been extensively used in aircraft structures.

Ply Level Properties (0°, 90°, and ±45° Laminates)

Data (ultimate strength, Young's modulus, and Poisson's ratio) from laminate tests of IM7/8551-7 and IM6/1808I are listed in tables 3 through 6. In assessing these data, attention is called to the fact that composite materials incorporating the 1808I resin matrix will have a lower fiber volume fraction than other laminated composites because of the thermoplastic interleaf film. Consequently, 1808I laminates will tend to have lower strength values than more conventional composite materials.

Data from tension tests of 0° laminates of IM7/8551-7 and IM6/1808I are listed in table 3. The 0° tension test primarily measures fiber capability and, in this instance, the IM7 fibers demonstrated much better performance than the IM6 fibers. Both fibers have a modulus of about 40 msi and a diameter of 5 microns, but the IM7 fibers have a somewhat greater failure strain than the IM6 fibers. The average tension strength of 366.4 ksi obtained for the IM7/8551-7 material, with a fiber volume of 54.6 percent, compares well with the 390-ksi value reported in reference 8 for a laminate with a fiber volume of 57 percent. Likewise, the strength value of 271 ksi obtained for IM6/1808I agrees well with the value of 265 ksi reported in reference 9. Average tension strength values are shown in figure 11(a) for four

graphite-epoxy materials: IM7/8551-7, IM6/1808I, HSC/1806, and T300/5208. Despite the wide variation in strengths, all four materials have similar values for tension modulus (fig. 11(b)).

Disappointing results for failure strength were obtained in short-block compression tests of 0° laminates. All specimens experienced end brooming failures at loads considerably less than expected. The stress-strain curves for 0° compression (figs. 9 and 10) do not show evidence of buckling prior to failure. The test fixture (fig. 6) clamps the specimen ends to reduce brooming, but it applies relatively low clamping forces that are probably insufficient to prevent early brooming. As a consequence of testing problems, the compression strength values are much lower than those reported elsewhere. The room temperature compression strength of IM7/8551-7 is given as 235 ksi in reference 8, and a value of 185 ksi for IM6/1808I is reported in reference 9, whereas the present values are 133 and 116 ksi, respectively. The compression modulus values obtained in this investigation are judged acceptable because the measurements were obtained well before specimen failure. Compression modulus values for the four materials considered are shown in figure 11(b).

Data from the 90° tension tests are listed in table 5 and average values of ply strength and modulus are plotted in figure 12 for the four materials. In these tests, load was applied normal to the fibers and, therefore, the test measures resin matrix strength. The results indicate that the 8551-7 resin has greater strength than the 1808I or 1806 resins. As expected, all the toughened resins have better strength than the relatively brittle 5208 resin material.

The ±45° tension test provides a measure of the performance of both fibers and resin matrix materials. The test results (table 6 and fig. 13) show similar strength and modulus for IM7/8551-7 and IM6/1808I. Both new materials show substantially higher strength than the older T300/5208 system. The latter has a higher ±45° modulus than the two newer materials.

Properties of Notched and Unnotched Quasi-Isotropic Laminates

Tension test data for unnotched quasi-isotropic laminates are given in table 7. Typical stress-strain curves are shown in figures 9 and 10. The average failure stress of 128.8 ksi for the IM7/8551-7 laminate was significantly higher than the stress of 104 ksi obtained with the IM6/1808I laminate. Because the

two materials have similar moduli, the difference in failure stress relates directly to failure strain.

To evaluate the measured ply level properties, a computer program based on the analysis presented in reference 10 was used to calculate the modulus of a quasi-isotropic [+45/0/-45/90] laminate. For both the IM7/8551-7 and IM6/1808I materials, good agreement was obtained between calculated and measured properties. The calculated Young's modulus of IM7/8551-7 was 7.70 msi, compared with the measured value of 7.61 msi. For IM6/1808I, the calculated modulus was 7.49 msi, compared with the measured value of 7.29 msi.

Tension test results for notched laminates are listed in table 8. All stress values are based on gross area. Room temperature, wet tests on a notched laminate of IM6/1808I material showed the anticipated insensitivity to environment, and for that reason, such tests were not performed on IM7/8551-7. In figure 14, the gross area failure stress and strain values are shown for unnotched and notched laminates made from four materials: IM7/8551-7, IM6/1808I, HSC/1806, and T300/5208. The materials that combine high-strain fibers with toughened resin matrices perform much better than the first generation T300/5208 system. The major message conveyed by figure 14 is one of enormous sensitivity to notch effects in even the best available composite materials.

For graphite-epoxy materials, tension properties are important, but compression properties are the vital indication of their potential usefulness. Unnotched and notched compression properties for IM7/8551-7 and IM6/1808I are listed in tables 9 and 10, respectively. Compression data for unnotched laminates were successfully obtained using short-block specimens; typical stress-strain curves are shown in figures 9 and 10. Figure 15 shows average strength and strain results for the notched and unnotched specimens and includes data for HSC/1806 laminates. All stress values are based on gross area. All three materials failed at about the same compression stress (87-90 ksi) in the unnotched condition. In the present tests, notched specimens of IM7/8551-7 performed slightly better than the IM6/1808I specimens over a range of hole sizes in room temperature, dry tests; cold (-65°F), dry specimens showed increased strength compared with room temperature, dry values. Note that all three materials suffer significant strength degradation from room temperature, dry values in 180°F, wet tests. Environmental effects were most pronounced for the IM7/8551-7 material, which showed a 35-percent reduction in compression strength when tested at 180°F wet.

Compression-After-Impact Results

Tests results for the quasi-isotropic panels impacted in this investigation are listed in table 11. Average values for failure stress and strain are plotted in figure 16, which also includes data for T300/5208 (from ref. 7) and HSC/1806 materials. As expected, the IM7/8551-7 and IM6/1808I materials—specifically formulated for impact and delamination resistance—performed much better than the first generation T300/5208 material.

It is important to note that the IM7/8551-7, IM6/1808I, and T300/5208 materials were impacted by using the Langley air gun apparatus, whereas the data for the HSC/1806 material were obtained from dropped-weight impact tests. For equal impact energies, the air gun produces greater damage than the dropped weight (ref. 3) and results in lower compression strength. In the present investigation, identical panels of IM7/8551-7 material were impacted with a dropped weight and the air gun. For equivalent energy impacts of 1000 in-lb per inch of panel thickness, the dropped-weight panels failed at a compression strength about 10 percent greater than the air gun panels. Consequently, the data for HSC/1806 material shown in figure 16 compare better than would be expected in a one-on-one comparison.

The 180°F, wet test results from the IM7/8551-7 and IM6/1808I panels indicate significant degradation in compression strengths compared with room temperature, dry test results. The combination of heat and moisture reduced the compression strength of IM7/8551-7 by 24 percent and that of IM6/1808I by 18 percent. The moisture level measurements discussed previously show that the relatively thick test panels were not fully moisture saturated when tested. However, the outer plies on the panels certainly reached a higher moisture content than the average measured values. Because the panels were soaked after being impacted, the damage site also provided a path for internal moisture penetration not available in undamaged laminates. However, as

noted previously, the specimen moisture levels were not measured.

An accepted measure of merit in compression-after-impact evaluations is for a material to demonstrate a failure stress of 50 ksi or 0.60 percent strain after impact at an energy level of 1500 in-lb per inch of laminate thickness. This corresponds to a 31.25-ft-lb impact on a 0.25-in-thick laminate. As shown in figure 16, neither the IM7/8551-7 nor the IM6/1808I material achieved the design goal in the present investigation. Without question, both materials offer major gains in damage tolerance compared with earlier composite materials, but further material improvements appear warranted.

Conclusions

Two composite materials made of toughened epoxy matrix and high-strain graphite fiber were tested to obtain ply level and laminate engineering properties. Tension and compression property data were generated for unnotched and notched quasi-isotropic laminates. Compression panels were impacted at various energy levels and residual compression strengths were determined. The effects of temperature and moisture on compression strength were investigated. The results of this experimental investigation support the following conclusions:

1. The IM7/8551-7 and IM6/1808I materials are substantially stronger and more damage tolerant than first-generation materials, such as T300/5208, which are in widespread use.
2. In this investigation, the IM7/8551-7 material outperformed the IM6/1808I material.
3. Neither material achieved the goal of 0.60 percent compression strain after impact at an energy level of 1500 in-lb per inch of laminate thickness.
4. The compression properties of both materials are significantly degraded by the combination of heat and moisture.

NASA Langley Research Center
Hampton, Virginia 23665-5225
May 17, 1988

References

1. Williams, J. G.; and Rhodes, M. D.: Effect of Resin on Impact Damage Tolerance of Graphite/Epoxy Laminates. *Composite Materials: Testing & Design (6th Conference)*, I. M. Daniel, ed., ASTM STP 787, c.1982, pp. 450-480.
2. Williams, Jerry G.: *Effect of Impact Damage and Open Holes on the Compression Strength of Tough Resin/High Strain Fiber Laminates*. NASA TM-85756, 1984.
3. Williams, Jerry G.; O'Brien, T. Kevin; and Chapman, A. J., III: Comparison of Toughened Composite Laminates Using NASA Standard Damage Tolerance Tests. *ACEE Composite Structures Technology—Review of Selected NASA Research on Composite Materials and Structures*, NASA CP-2321, 1984, pp. 51-73.
4. ACEE Composites Project Office, compiler: *NASA/Aircraft Industry Standard Specification for Graphite Fiber/Toughened Thermoset Resin Composite Material*. NASA RP-1142, 1985.
5. ACEE Composites Project Office, compiler: *Standard Tests for Toughened Resin Composites—Revised Edition*. NASA RP-1092, 1983. (Supersedes NASA RP-1092, 1982.)
6. Dexter, H. Benson; and Funk, Joan G.: Impact Resistance and Interlaminar Fracture Toughness of Through-the-Thickness Reinforced Graphite/Epoxy. *27th Structures, Structural Dynamics and Materials Conference—Technical Papers, Part 1*, American Inst. of Aeronautics & Astronautics, 1986, pp. 700-709. (Available as AIAA-86-1020.)
7. Ekvall, J. C.; and Griffin, C. F.: Design Allowables for T300/5208 Graphite/Epoxy Composite Materials. *A Collection of Technical Papers, Part I—AIAA/ASME/ASCE/AHS 22nd Structures, Structural Dynamics & Materials Conference*, American Inst. of Aeronautics & Astronautics, c.1981, pp. 416-422. (Available as AIAA-81-0541.)
8. Gawin, Irena: Tough Thermosetting Resins With Superior Damage Tolerance Hercules 8551 Series. *Materials Sciences for the Future—31st International SAMPE Symposium and Exhibition*, Jerome L. Bauer and Robert Dunaetz, eds., Soc. for the Advancement of Material and Process Engineering, 1986, pp. 1204-1213.
9. Madan, Ram C.: *Composite Transport Wing Technology Development*. NASA CR-178409, 1988.
10. Ashton, J. E.; Halpin, J. C.; and Petit, P. H.: *Primer on Composite Materials: Analysis*. Technomic Publ. Co., Inc., c.1969.

Table 1. Composite Prepreg Characteristics

IM7/8551-7:

Hercules 8551-7 (IM7 fibers) 12-in-wide tape
Fiber areal weight of 145 g/m²
Wet resin content of 35 ± 3 percent, by weight
350°F cure temperature
Volatile content <15 percent
Lot X4150-Y, spools 6C and 6D

IM6/1808I:

Cycom X-1808 TPI 5000 GTC grade 14_S (Hercules IM6 fibers) 12-in-wide tape
Nominal thickness of 0.0061–0.0062 in. per ply
Fiber areal weight of 145 g/m²
Volatile content <1 percent
350°F cure temperature
Batch number B-209

Table 2. Test Matrix

(a) IM7/8551-7

Laminate	Loading	Test condition (a)	Size		Quantity	Specimen drawing, see figure —
			Length, in.	Width, in.		
[0] ₈	0° tension	RTD, unnotched	9.00	1.00	5	5(a)
[0] ₁₆	0° compression	RTD, unnotched	1.75	1.50	5	5(b)
[90] ₈	90° tension	RTD, unnotched	9.00	1.00	5	5(a)
[±45] ₄	±45° tension	RTD, unnotched	10.00	1.00	5	5(a)
[+45/0/-45/90] _{2S}	Tension	RTD, unnotched	10.00	1.00	3	5(c)
[+45/0/-45/90] _{2S}	Tension	RTD, 0.25-in. hole	10.00	1.50	2	5(d)
[+45/0/-45/90] _{2S}	Tension	RTD, 0.50-in. hole	10.00	3.00	2	5(d)
[+45/0/-45/90] _{6S}	Compression	RTD, unnotched	10.00	3.00	2	
[+45/0/-45/90] _{6S}	Compression	RTD, unnotched	1.75	1.50	4	5(b)
[+45/0/-45/90] _{6S}	Compression	RTD, 0.25-in. hole	10.00	3.00	2	5(e)
[+45/0/-45/90] _{6S}	Compression	HW, 0.25-in. hole	10.00	3.00	2	5(e)
[+45/0/-45/90] _{6S}	Compression	CD, 0.25-in. hole	10.00	3.00	2	5(e)
[+45/0/-45/90] _{6S}	Compression	RTD, 0.50-in. hole	10.00	3.00	3	5(e)
[+45/0/-45/90] _{6S}	Compression	RTD, 1.00-in. hole	10.00	5.00	3	5(e)
[+45/0/-45/90] _{6S}	Compression	RTD, 10 ft-lb impact	10.00	5.00	2	5(f)
[+45/0/-45/90] _{6S}	Compression	RTD, 20 ft-lb impact	10.00	5.00	2	5(f)
[+45/0/-45/90] _{6S}	Compression	RTD, 30 ft-lb impact	10.00	5.00	2	5(f)
[+45/0/-45/90] _{6S}	Compression	HW, 30 ft-lb impact	10.00	5.00	2	5(f)

^aRTD = Room temperature, ambient moisture content.

HW = 180°F, wet.

CD = -65°F, ambient moisture content.

Table 2. Concluded

(b) IM6/1808I

Laminate	Loading	Test condition (a)	Size		Quantity	Specimen drawing, see figure —
			Length, in.	Width, in.		
[0] ₈	0° tension	RTD, unnotched	9.00	1.00	5	5(a)
[0] ₁₆	0° compression	RTD, unnotched	1.75	1.50	5	5(b)
[90] ₈	90° tension	RTD, unnotched	9.00	1.00	5	5(a)
[±45] ₄	±45° tension	RTD, unnotched	10.00	1.00	5	5(a)
[+45/0/-45/90] _{2S}	Tension	RTD, unnotched	12.00	1.00	3	5(c)
[+45/0/-45/90] _{2S}	Tension	RTD, 0.25-in. hole	12.00	1.50	2	5(d)
[+45/0/-45/90] _{2S}	Tension	RTW, 0.25-in. hole	12.00	1.50	2	5(d)
[+45/0/-45/90] _{2S}	Tension	RTD, 0.50-in. hole	12.00	3.00	2	5(d)
[+45/0/-45/90] _{5S}	Compression	RTD, unnotched	10.00	3.00	2	
[+45/0/-45/90] _{5S}	Compression	RTD, unnotched	1.75	1.50	4	5(b)
[+45/0/-45/90] _{5S}	Compression	RTD, 0.25-in. hole	10.00	3.00	2	5(e)
[+45/0/-45/90] _{5S}	Compression	HW, 0.25-in. hole	10.00	3.00	2	5(e)
[+45/0/-45/90] _{5S}	Compression	CD, 0.25-in. hole	10.00	3.00	2	5(e)
[+45/0/-45/90] _{5S}	Compression	RTD, 0.50-in. hole	10.00	3.00	3	5(e)
[+45/0/-45/90] _{5S}	Compression	RTD, 1.00-in. hole	10.00	5.00	3	5(e)
[+45/0/-45/90] _{5S}	Compression	RTD, 10 ft-lb impact	10.00	5.00	2	5(f)
[+45/0/-45/90] _{5S}	Compression	RTD, 20 ft-lb impact	10.00	5.00	2	5(f)
[+45/0/-45/90] _{5S}	Compression	RTD, 30 ft-lb impact	10.00	5.00	2	5(f)
[+45/0/-45/90] _{5S}	Compression	HW, 30 ft-lb impact	10.00	5.00	2	5(f)

^aRTD = Room temperature, ambient moisture content.

RTW = Room temperature, wet.

HW = 180°F, wet.

CD = -65°F, ambient moisture content.

Table 3. 0° Tension Tests

(a) IM7/8551-7

[Laminate [0]₈; nominal thickness 0.049 in.]

Specimen	Fiber volume, percent	Failure load, kips	Failure stress, ksi	Failure strain, percent	Modulus, msi (a)	Poisson's ratio (a)
T1	54.6	16.76	342.8	1.52	20.3	0.33
T2	54.6	17.59	366.4	1.63	19.5	0.33
T3	54.6	19.03	388.4	1.64	20.7	0.33
T4	54.6	17.96	366.8	1.62	20.1	0.33
T5	54.6	17.63	367.7	1.58	20.2	0.32
Average			366.4	1.60	20.2	0.33
Standard deviation			14.4	0.04	0.4	0.004

^aValues of modulus and Poisson's ratio measured at 0.2 percent strain.

(b) IM6/1808I

[Laminate [0]₈; nominal thickness 0.051 in.]

Specimen	Fiber volume, percent	Failure load, kips	Failure stress, ksi	Failure strain, percent	Modulus, msi (a)	Poisson's ratio (a)
C-1(1)	49.1	14.07	275	1.37	20.1	0.33
C-1(2)	49.1	14.89	286	1.40	20.3	0.32
C-1(3)	49.1	13.74	269	1.35	19.9	0.33
C-1(4)	49.1	13.32	261	1.32	19.8	0.36
C-1(5)	49.1	13.86	266	1.36	19.6	0.35
Average			271	1.36	19.9	0.34
Standard deviation			8.6	0.03	0.2	0.01

^aValues of modulus and Poisson's ratio measured at 0.2 percent strain.

Table 4. 0° Compression Tests

(a) IM7/8551-7

[Laminate [0]₁₆; nominal thickness 0.094 in.]

Specimen	Fiber volume, percent	Failure load, kips (a)	Failure stress, ksi	Failure strain, percent	Modulus, msi (b)	Poisson's ratio (b)
C-1	54.2	18.57	133.2	0.71	19.3	0.30
C-2	54.2	19.59	135.6	0.74	19.4	0.29
C-3	54.2	18.45	129.1	0.70	18.8	0.32
C-4	54.2	18.78	132.7	0.73	18.4	0.37
C-5	54.2	18.73	131.0	0.72	18.4	0.35
Average			132.9	0.72	18.9	0.33
Standard deviation			3.2	0.01	0.4	0.03

^aAll specimens failed in “end brooming” mode.

^bValues of modulus and Poisson's ratio measured at 0.2 percent strain.

(b) IM6/1808I

[Laminate [0]₁₆; nominal thickness 0.104 in.]

Specimen	Fiber volume, percent	Failure load, kips (a)	Failure stress, ksi	Failure strain, percent	Modulus, msi (b)	Poisson's ratio (b)
OC1	50.8	19.21	123.0	0.70	19.4	0.32
OC2	50.8	18.52	118.6	0.67	19.5	0.29
OC3	50.8	18.66	118.3	0.66	19.5	0.29
OC4	50.8	16.73	105.1	0.59	19.2	0.32
^c OC5	50.8					
Average			116.3	0.66	19.4	0.31
Standard deviation			6.7	0.04	0.1	0.02

^aAll specimens failed in “end brooming” mode.

^bValues of modulus and Poisson's ratio measured at 0.2 percent strain.

^cNonuniform thickness specimen.

Table 5. 90° Tension Tests

(a) IM7/8551-7

[Laminate [90]8; nominal thickness 0.048 in.]

Specimen	Fiber volume, percent	Failure load, kips	Failure stress, ksi	Failure strain, percent	Modulus, msi (a)	Poisson's ratio (a)
T6	54.6	0.429	9.3	0.74	1.31	0.012
T7	54.6	0.537	11.2	0.93	1.65	0.012
T8	54.6	0.585	12.2	0.90	1.40	0.013
T9	54.6	0.480	9.8	0.92	1.35	0.012
T10	54.6	0.529	11.0	0.99	1.08	0.011
Average			10.7	0.90	1.36	0.012
Standard deviation			1.0	0.08	0.18	0.001

^aValues of modulus and Poisson's ratio measured at 0.2 percent strain.

(b) IM6/1808I

[Laminate [90]8; nominal thickness 0.052 in.]

Specimen	Fiber volume, percent	Failure load, kips	Failure stress, ksi	Failure strain, percent	Modulus, msi (a)	Poisson's ratio (a)
^b C-1(6)	49.1					
C-1(7)	49.1	0.390	7.47	0.71	1.13	0.012
C-1(8)	49.1	0.364	6.99	0.64	1.14	0.014
C-1(9)	49.1	0.347	6.68	0.64	1.10	0.014
C-1(10)	49.1	0.356	7.40	0.69	1.13	0.013
Average			7.14	0.67	1.13	0.013
Standard deviation			0.32	0.03	0.02	0.001

^aValues of modulus and Poisson's ratio measured at 0.1 percent strain.

^bSpecimen accidentally destroyed.

Table 6. $\pm 45^\circ$ Tension Tests

(a) IM7/8551-7

[Laminate $[+45/-45]_{2S}$; nominal thickness 0.046 in.]

Specimen	Fiber volume, percent	Maximum stress, ksi	Extensional modulus, msi (a)	Shear modulus, ^b ksi (a)	Poisson's ratio (a)
T11	54.7	36.0	2.4	668	0.79
T12	54.7	36.4	2.3	655	0.79
T13	54.7	36.0	2.2	622	0.78
T14	54.7	33.8	2.5	691	0.79
T15	54.7	33.0	2.2	630	0.78
Average		35.0	2.3	653	0.79
Standard deviation		1.4	0.1	25	0.01

^aValues of moduli and Poisson's ratio measured at 0.32 percent strain.

^bIn-plane shear modulus value calculated for 0° laminate.

(b) IM6/1808I

[Laminate $[+45/-45]_{2S}$; nominal thickness 0.052 in.]

Specimen	Fiber volume, percent	Maximum stress, ksi	Extensional modulus, msi (a)	Shear modulus, ksi (b)	Poisson's ratio (a)
^c C-3(1)	53.6	33.4			
C-3(2)	53.6	31.9	2.017	575	0.74
C-3(3)	53.6	32.5	2.009	561	0.78
C-3(4)	53.6	31.8	2.316	656	0.77
C-3(5)	53.6	31.9	2.040	548	0.72
Average		32.3	2.096	585	0.75
Standard deviation		0.6	0.128	42	0.02

^aValues of modulus and Poisson's ratio measured at 0.1 percent strain.

^bIn-plane shear modulus value calculated for 0° laminate.

^cStrain data not obtained for specimen C-3(1).

Table 7. Quasi-Isotropic Unnotched Tension Tests

(a) IM7/8551-7

[Laminate [+45/0/-45/90]_{2S}; nominal thickness 0.098 in.]

Specimen	Fiber volume, percent	Failure load, kips	Failure stress, ksi	Failure strain, percent	Modulus, msi (a)	Poisson's ratio (a)
UT1	61.6	12.4	128.0	1.66	7.63	0.29
UT2	61.6	12.7	129.7	1.68	7.32	0.29
UT3	61.6	12.6	128.8	1.67	7.89	0.29
Average			128.8	1.67	7.61	0.29
Standard deviation			0.7	0.01	0.23	

^aValues of modulus and Poisson's ratio measured at 0.2 percent strain.

(b) IM6/1808I

[Laminate [+45/0/-45/90]_{2S}; nominal thickness 0.101 in.]

Specimen	Fiber volume, percent	Failure load, kips	Failure stress, ksi	Failure strain, percent	Modulus, msi (a)
C-4U(1)	50.1	16.2	109	1.45	7.26
C-4U(2)	50.1	15.2	101	1.35	7.33
C-4U(3)	50.1	15.3	102	1.36	7.28
Average			104	1.39	7.29
Standard deviation			3.6	0.05	0.03

^aValue of modulus measured at 0.2 percent strain.

Table 8. Quasi-Isotropic Notched Tension Tests

(a) IM7/8551-7

[Laminate [+45/0/-45/90]_{2S}; nominal thickness 0.096 in.]

Specimen	Fiber volume, percent	Hole diam, in.	Failure load, kips	Failure stress, ksi	Failure strain, percent (a)
HT1	61.6	0.25	9.11	63.9	0.82
HT2	61.6	0.25	9.09	62.4	0.82
Average				63.2	0.82
HT3	61.6	0.50	16.6	57.5	0.71
HT4	61.6	0.50	16.5	56.8	0.71
Average				57.2	0.71

^aFailure strain measured by gages.

(b) IM6/1808I

[Laminate [+45/0/-45/90]_{2S}; nominal thickness 0.101 in.]

Specimen	Fiber volume, percent	Hole diam, in.	Failure load, kips	Failure stress, ksi	Failure strain, percent (a)
C-4(1)	50.1	0.25	8.12	53.9	0.71
C-4(2)	50.1	0.25	7.55	49.6	0.66
C-4(3)	50.1	0.25	8.41	55.2	0.72
Average				52.9	0.70
Standard deviation				2.4	0.03
C-4(7)	50.1	0.25 RTW	7.96	52.3	0.70
C-4(8)	50.1	0.25 RTW	7.94	52.3	0.71
C-4(9)	50.1	0.25 RTW	8.06	53.4	0.72
Average				52.7	0.71
Standard deviation				0.5	0.01
C-9(1)	50.1	0.50	13.5	44.4	0.58
C-9(2)	50.1	0.50	13.5	44.3	0.57
C-9(3)	50.1	0.50	13.7	45.6	0.58
Average				44.8	0.58
Standard deviation				0.6	0.01

^aFailure strain measured by gages.

Table 9. Quasi-Isotropic Unnotched Compression Tests

(a) IM7/8551-7

[Laminate [+45/0/-45/90]_{6S}; nominal thickness 0.280 in.]

Specimen	Fiber volume, percent	Failure load, kips	Failure stress, ksi	Failure strain, percent	Modulus, msi (a)	Poisson's ratio (a)
^b U1	49.2	60.5	70.1	1.03	7.83	
^b U2	49.2	65.2	75.8	1.12	8.02	
7-1	55.6	37.5	89.7	1.40	7.01	0.32
7-3	55.6	37.0	87.8	1.38	6.91	0.32
7-4	55.6	38.5	92.0	1.42		
7-5	55.6	38.0	90.2	1.42	7.12	0.31
Average			89.9	1.41	7.01	0.32
Standard deviation			1.5	0.02	0.09	0.01

^aValues of modulus and Poisson's ratio measured at 0.2 percent strain.

^bSpecimen (10 in. × 3 in.) buckled; data not included in average values.

(b) IM6/1808I

[Laminate [+45/0/-45/90]_{5S}; nominal thickness 0.251 in.]

Specimen	Fiber volume, percent	Failure load, kips	Failure stress, ksi	Failure strain, percent	Modulus, msi (a)	Poisson's ratio (a)
^b C-5U(1)	53.2	46.6	61.8	0.98	7.06	
^b C-5U(2)	53.2	44.8	59.3	0.95	6.99	
6-1	53.2	31.0	82.3	1.36	6.93	0.32
6-2	53.2	32.8	87.1	1.46	7.03	0.32
6-3	53.2	34.9	92.3	1.52	7.07	0.32
6-4	53.2	32.6	86.1	1.46	6.85	0.33
Average			87.0	1.45	6.97	0.32
Standard deviation			3.6	0.06	0.09	0.00

^aValues of modulus and Poisson's ratio measured at 0.2 percent strain.

^bSpecimen (10 in. × 3 in.) buckled; data not included in average values.

Table 10. Quasi-Isotropic Notched Compression Tests

(a) IM7/8551-7

[Laminate [+45/0/-45/90]_{6S}; nominal thickness 0.281 in.]

Specimen	Fiber volume, percent	Hole diam, in.	Condition (a)	Failure load, kips	Failure stress, ksi	Failure strain, percent (b)	Modulus, msi
H3	55.4	0.25	RTD	42.7	50.8	0.70	7.76
H4	55.4	0.25	RTD	44.5	53.0	0.72	7.90
Average					51.9	0.71	7.83
H1	55.4	0.25	CD	49.6	58.9	0.81	7.62
^c H2	55.4	0.25	CD				
H5	55.4	0.25	HW	28.8	34.0	0.50	7.21
H6	55.4	0.25	HW	29.0	34.3	0.43	7.65
Average					34.2	0.47	7.43
HC1	59.2	0.50	RTD	38.4	44.8	0.57	8.56
HC2	59.2	0.50	RTD	37.3	43.6	0.55	8.58
HC3	59.2	0.50	RTD	36.2	42.1	0.54	8.48
Average					43.5	0.55	8.54
Standard deviation					1.1	0.01	0.04
HC4	59.2	1.00	RTD	53.1	37.3	0.50	7.69
HC5	59.2	1.00	RTD	50.9	36.0	0.48	7.73
HC6	59.2	1.00	RTD	54.8	41.3	0.52	8.24
Average					38.2	0.50	7.89
Standard deviation					2.3	0.02	0.25

^aRTD = Room temperature, ambient moisture content.

CD = -65°F, ambient moisture content.

HW = 180°F, wet.

^bFailure strains measured by strain gages.

^cSpecimen experienced end failure.

Table 10. Concluded

(b) IM6/1808I

[Laminate [+45/0/-45/90]_{5S}; nominal thickness 0.251 in.]

Specimen	Fiber volume, percent	Hole diam, in.	Condition (a)	Failure load, kips	Failure stress, ksi	Failure strain, percent (b)	Modulus, msi
^c C-5(3)	53.2	0.25	RTD	27.9			
C-5(4)	53.2	0.25	RTD	35.0	46.3	0.71	6.97
C-5(1)	53.2	0.25	CD	41.6	55.1	0.71	
C-5(2)	53.2	0.25	CD	41.8	55.5	0.84	7.31
Average					55.3	0.80	
C-5(5)	53.2	0.25	HW	26.1	34.5	0.51	6.96
C-5(6)	53.2	0.25	HW	26.0	34.5	0.51	6.90
Average					34.5	0.51	6.93
C-6(1)	53.2	0.50	RTD	30.1	40.1	0.56	7.65
C-6(2)	53.2	0.50	RTD	31.4	41.7	0.59	7.57
Average					40.9	0.58	7.61
C-7(1)	53.2	1.00	RTD	42.0	33.4	0.47	7.22
C-7(2)	53.2	1.00	RTD	42.7	33.8	0.48	7.17
C-7(3)	53.2	1.00	RTD	44.1	35.2	0.50	7.19
Average					34.1	0.48	7.19
Standard deviation					0.8	0.01	0.02

^aRTD = Room temperature, ambient moisture content.

CD = -65°F, ambient moisture content.

HW = 180°F, wet.

^bFailure strains measured by strain gages.

^cSpecimen experienced end failure.

Table 11. Quasi-Isotropic Postimpact Compression Tests

(a) IM7/8551-7

[Laminate [+45/0/-45/90]_{6S}; nominal thickness 0.282 in.]

Specimen	Fiber volume, percent	Impact, ft-lb	Damage area, in ²	Failure load, kips	Failure stress, ksi	Failure strain, percent
I1	55.6	11	1.10	85.7	61.2	0.85
I2	55.6	11	0.83	85.9	61.1	0.86
Average					61.2	0.86
I3	55.6	22	2.22	59.9	42.7	0.58
I4	55.6	22	1.66	66.3	46.9	0.64
Average					44.8	0.61
I5	55.6	30	2.44	55.5	39.6	0.53
I7	49.2	30		57.9	40.1	0.56
Average					39.9	0.55
^a I6	55.6	30	1.88	41.8	29.7	0.40
^a I8	49.2	30		44.1	30.8	0.44
Average					30.3	0.42

^aSpecimen tested in hot (180°F), wet condition.

(b) IM6/1808I

[Laminate [+45/0/-45/90]_{5S}; nominal thickness 0.251 in.]

Specimen	Fiber volume, percent	Impact, ft-lb	Damage area, in ²	Failure load, kips	Failure stress, ksi	Failure strain, percent
C-8(4)	53.2	10	0.42	73.8	58.9	0.87
C-8(5)	53.2	10	0.40	77.2	61.6	0.91
Average					60.3	0.89
C-8(6)	53.2	20	1.86	48.9	38.8	0.55
C-8(7)	53.2	20	2.60	49.6	39.5	0.55
Average					39.2	0.55
C-8(8)	53.2	30	3.31	40.0	31.9	0.53
AG-2	53.2	30	3.07	42.9	34.0	0.48
Average					33.0	0.46
^a C-8(9)	53.2	30	3.17	35.7	28.4	0.42
^a C-8(10)	53.2	30	3.11	32.2	25.7	0.38
Average					27.1	0.40

^aSpecimen tested in hot (180°F), wet condition.

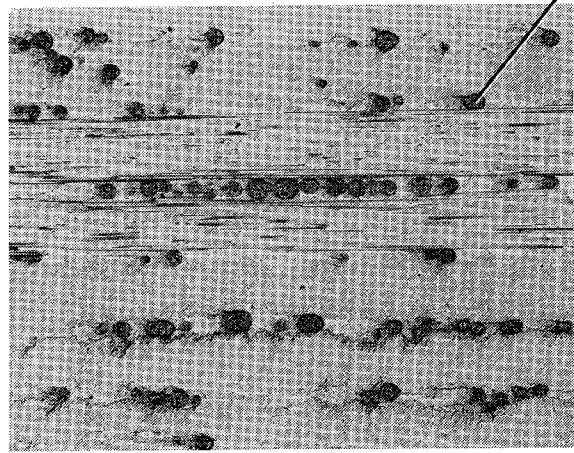
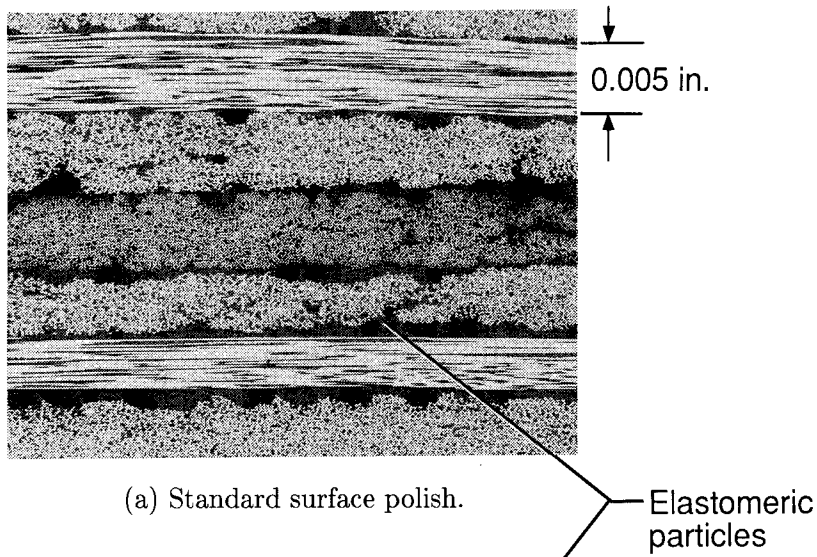

L-88-101

Figure 1. Cross section of IM7/8551-7.

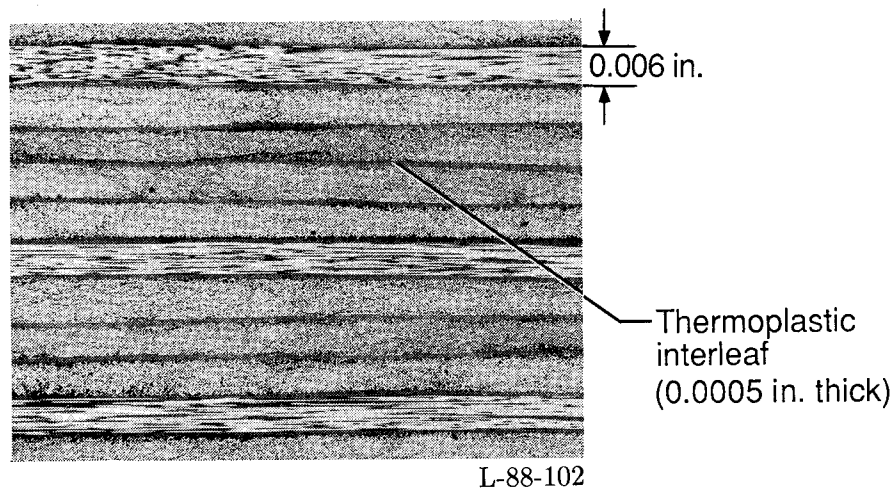

Figure 2. Cross section of IM6/1808I.

Cure Procedure

1. Place lay-up in room temperature autoclave, apply 25 in. Hg vacuum minimum.
2. Apply 85^{+15}_{-0} psig pressure to laminates.
3. Vent vacuum bag to atmosphere when autoclave pressure reaches 20 psig.
4. Start heat cycle.
5. When laminate cools to 140°F, release pressure.

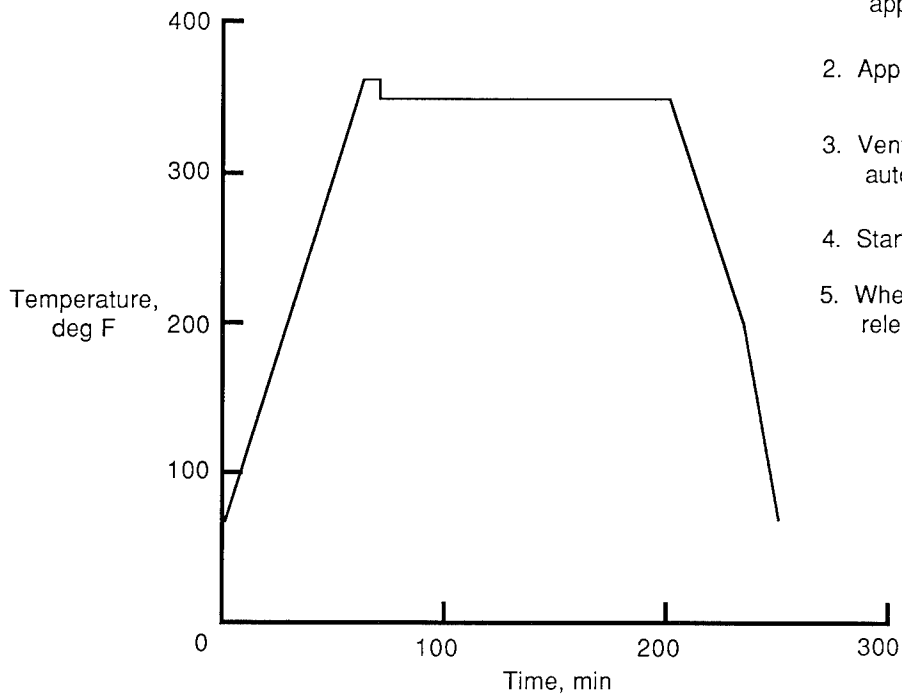

Figure 3. Standard cure cycle.

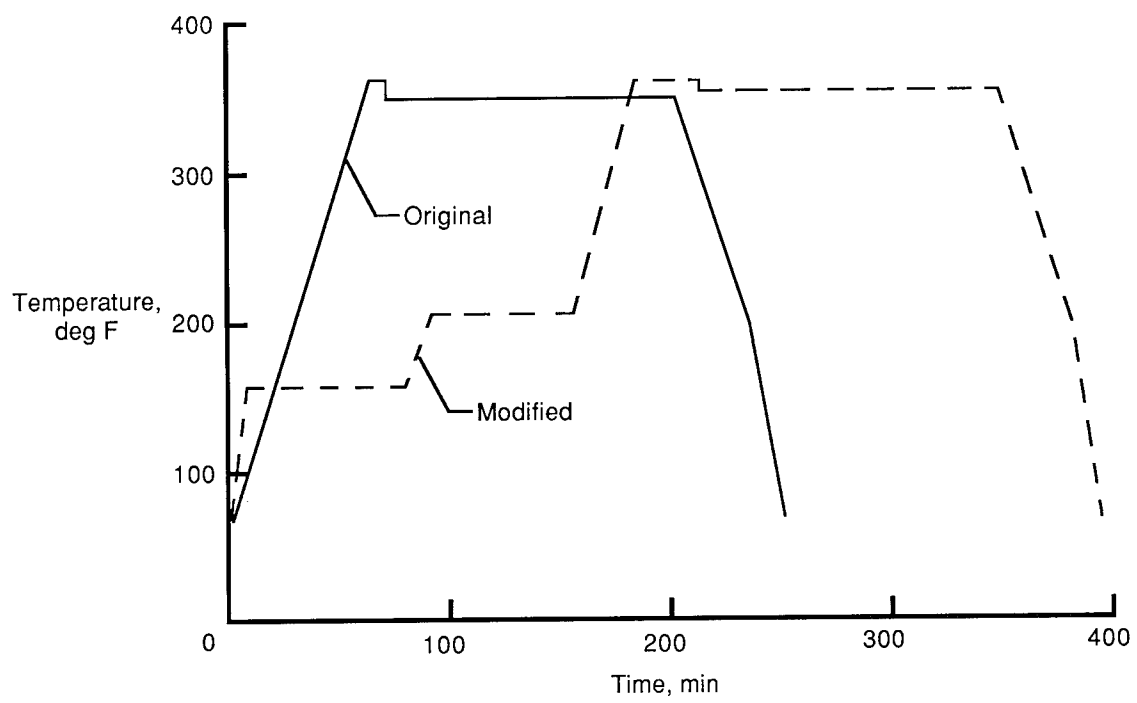
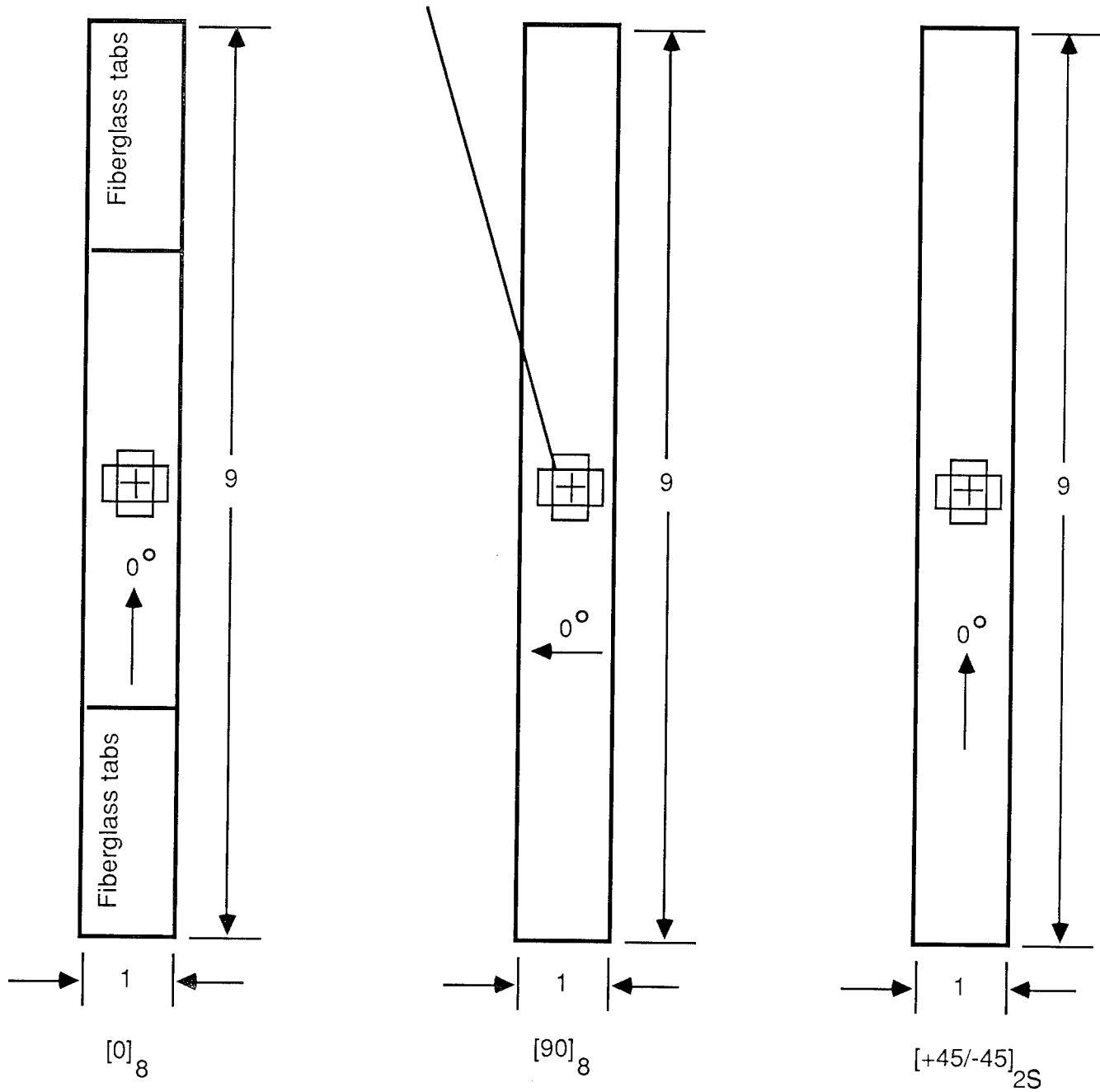

Figure 4. Modified cure cycle for IM7/8551-7 laminates.

Strain gages: centered,
0/90 stacked, back-to-back



(a) Ply level tension specimens. All dimensions in inches.

Figure 5. Specimen configurations.

Strain gages: centered,
0/90 stacked, back-to-back

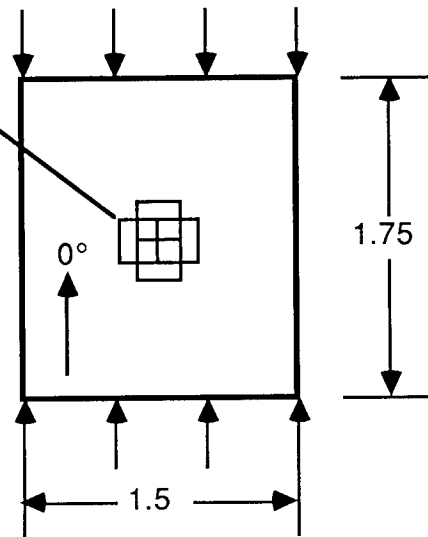

(b) Short-block compression specimen. All dimensions in inches.

Figure 5. Continued.

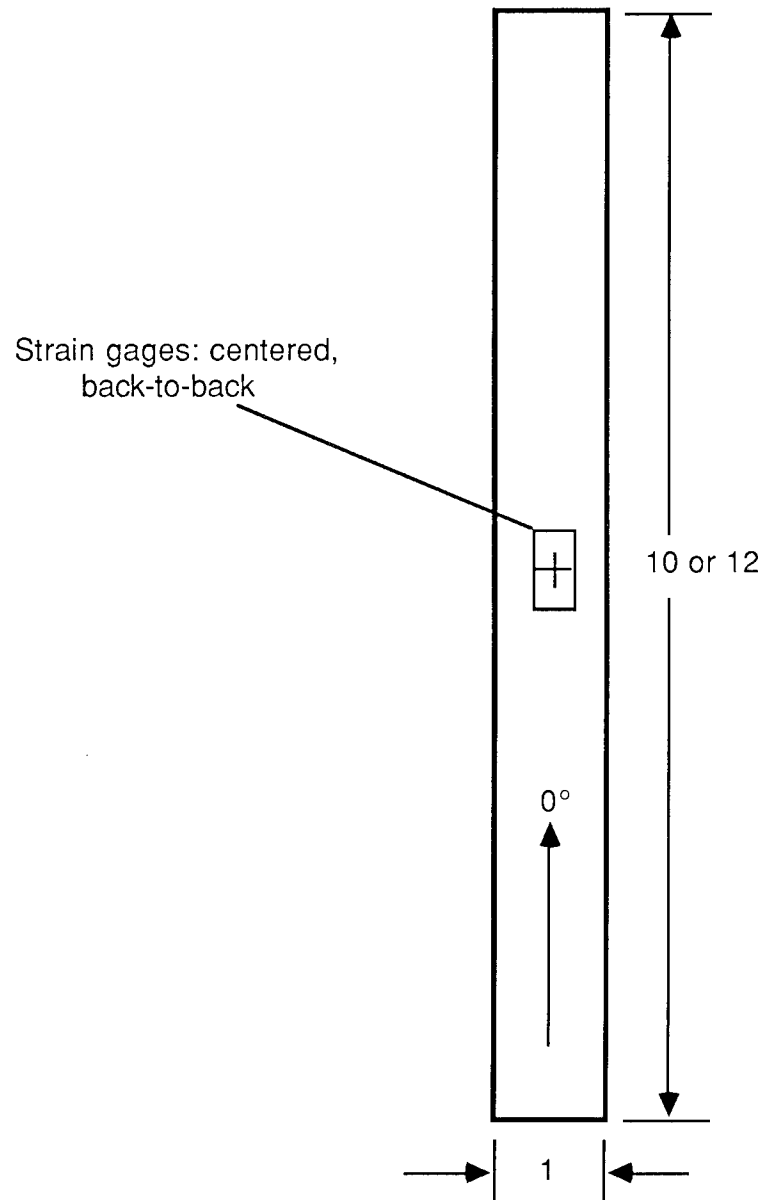

(c) Unnotched tension specimen for quasi-isotropic laminates. All dimensions in inches.

Figure 5. Continued.

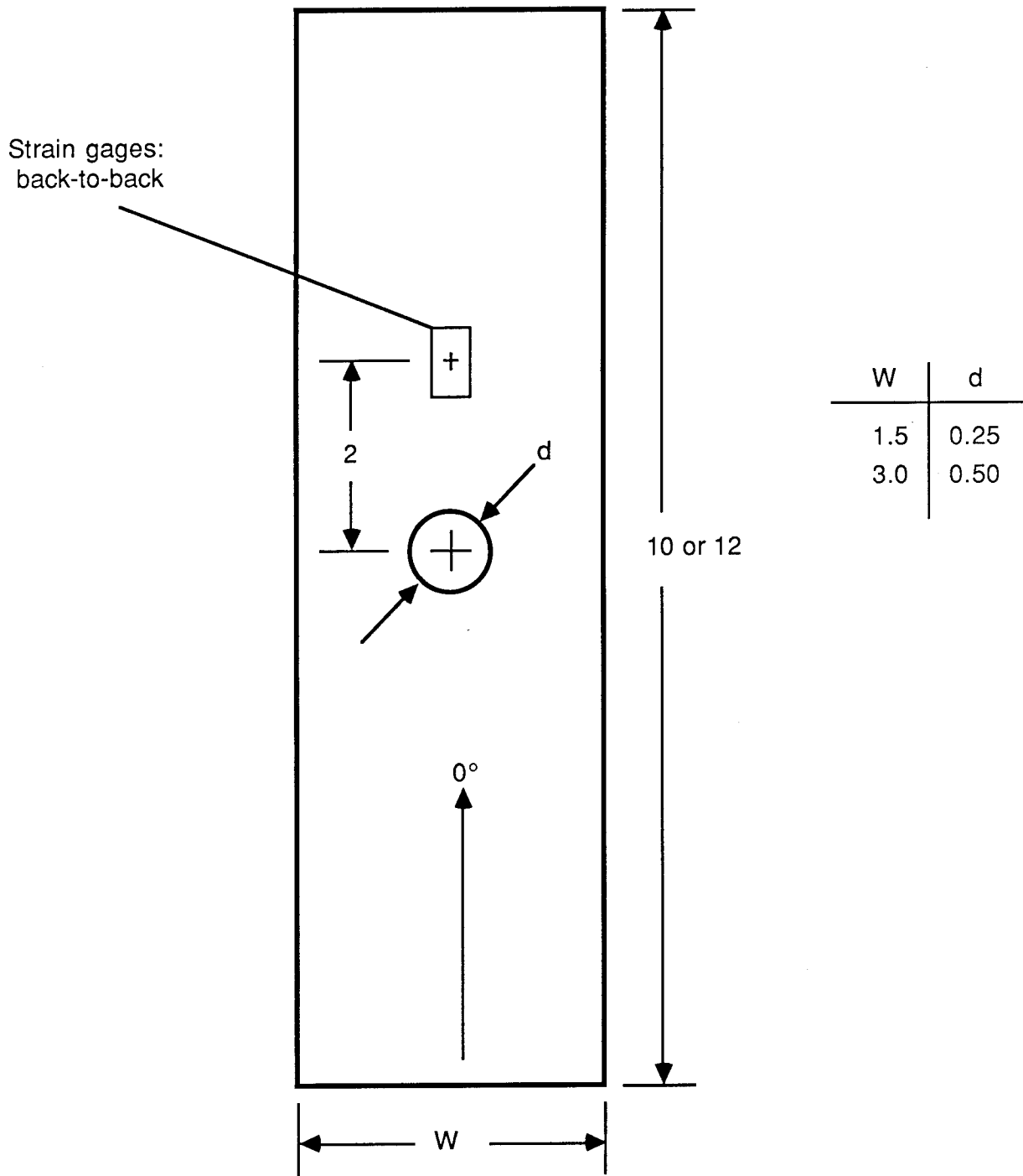

(d) Open-hole tension specimens. All dimensions in inches.

Figure 5. Continued.

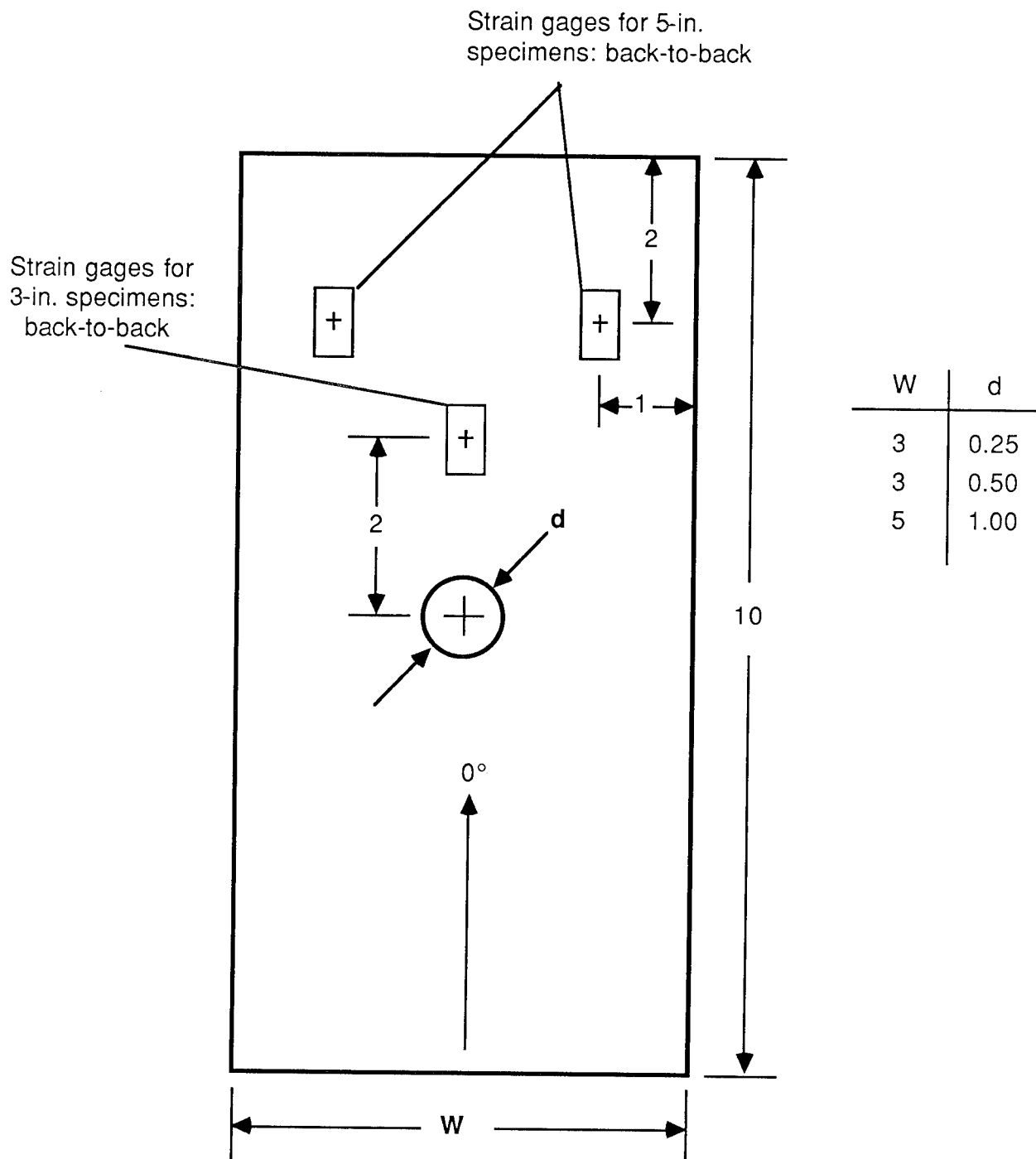

(e) Open-hole compression specimens. All dimensions in inches.

Figure 5. Continued.

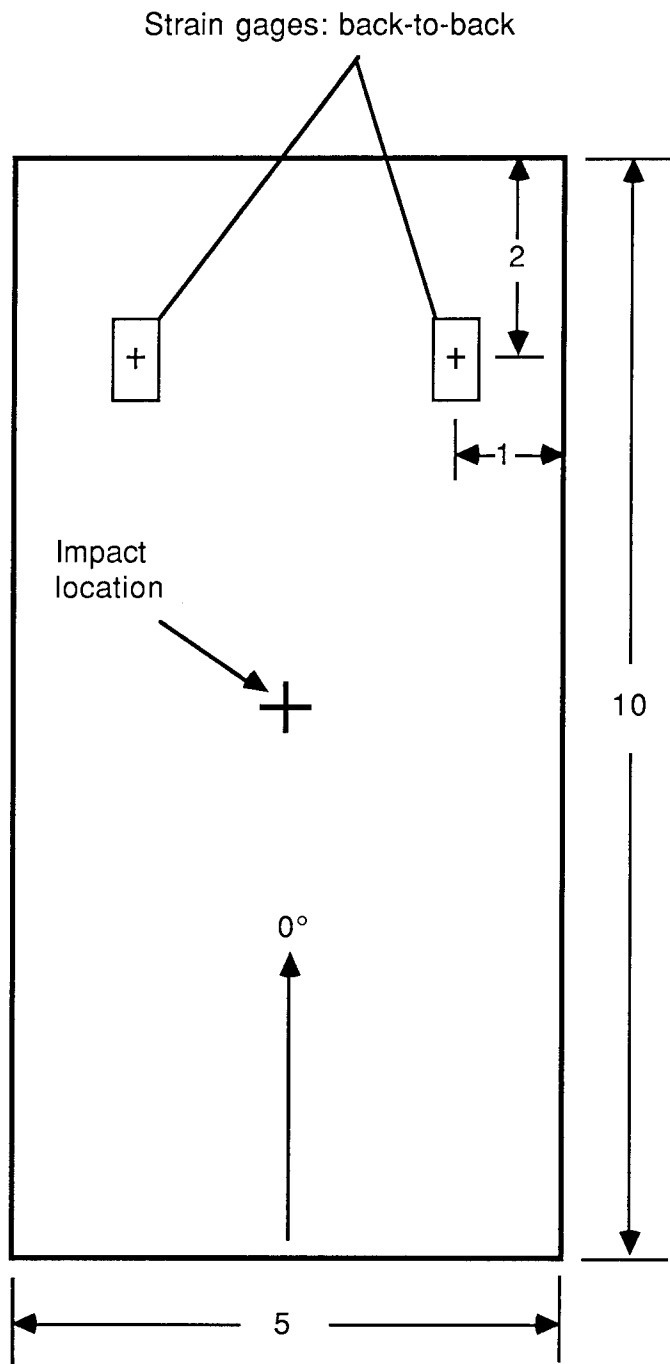

(f) Compression-after-impact specimen. All dimensions in inches.

Figure 5. Concluded.

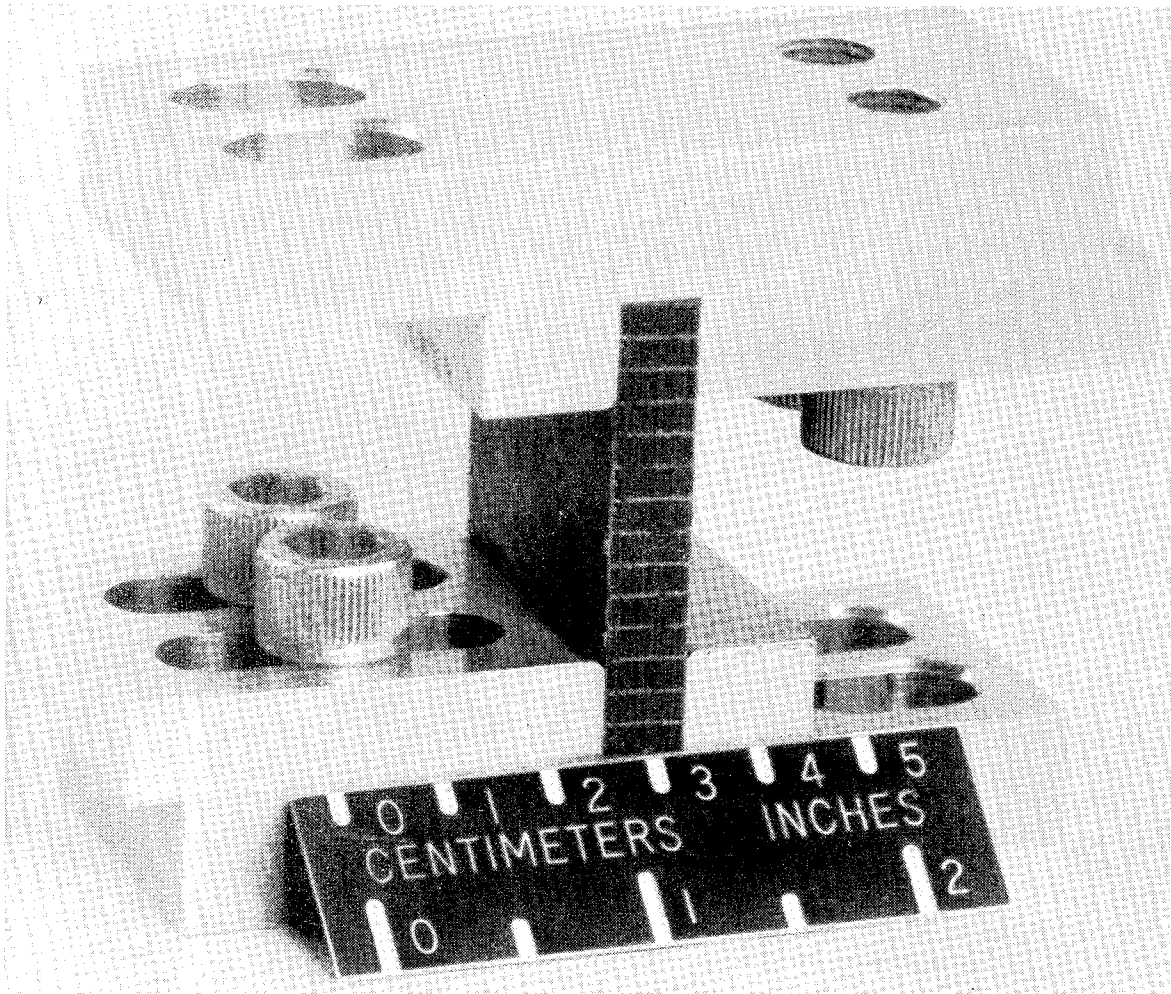

L-85-11,866

Figure 6. Short-block compression test fixture.

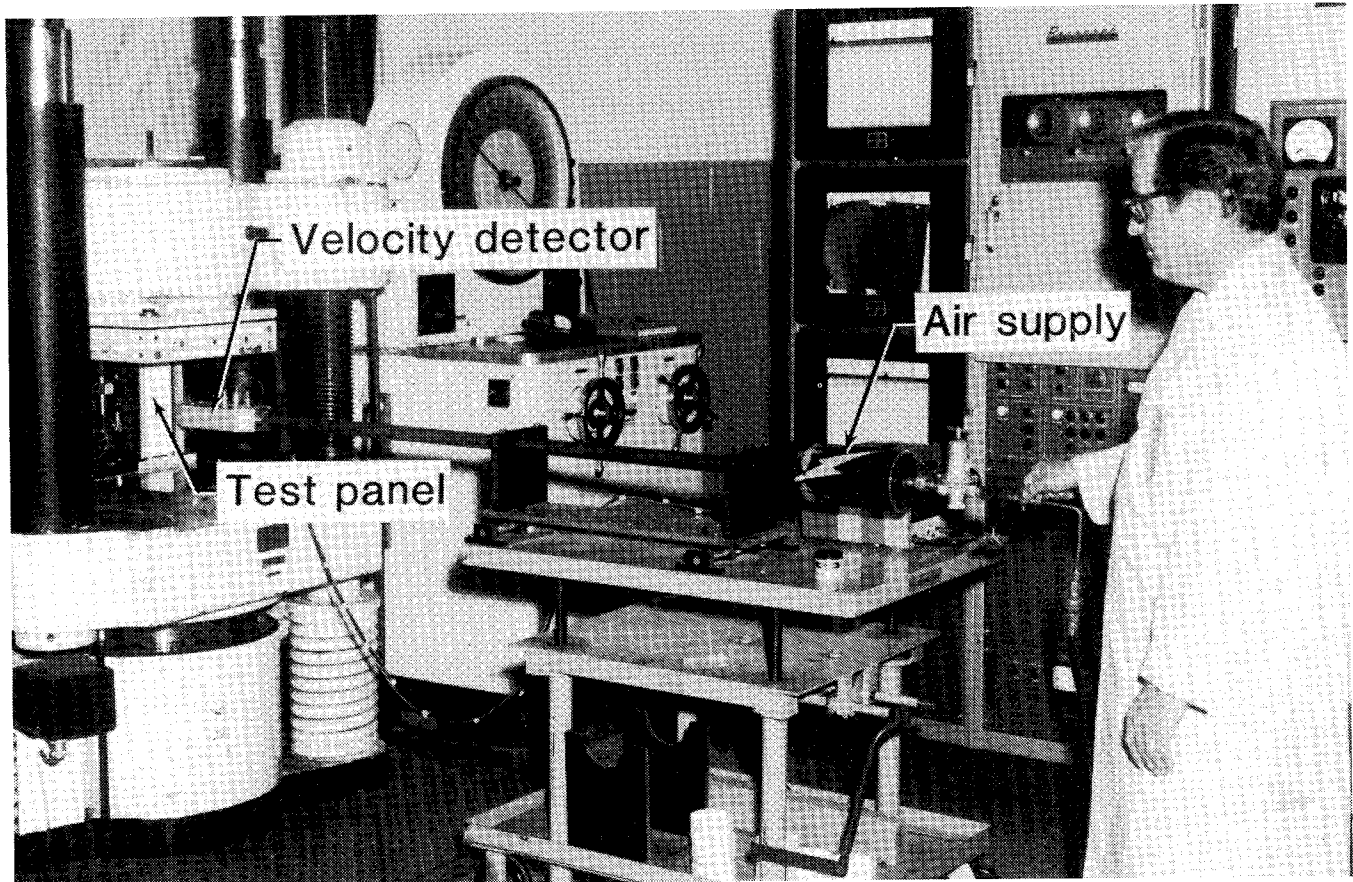

L-88-103

Figure 7. Impact test apparatus.

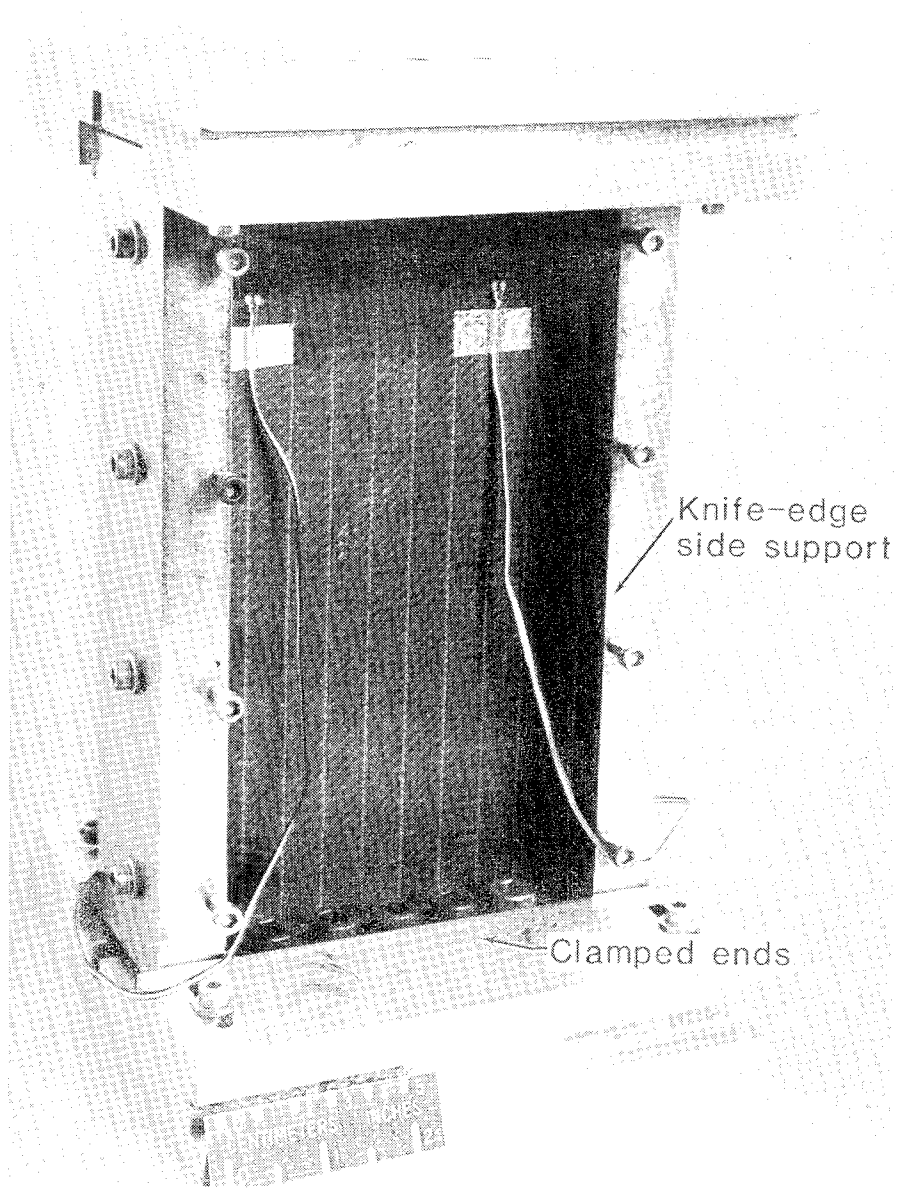

L-85-13,447

Figure 8. Compression-after-impact test apparatus.

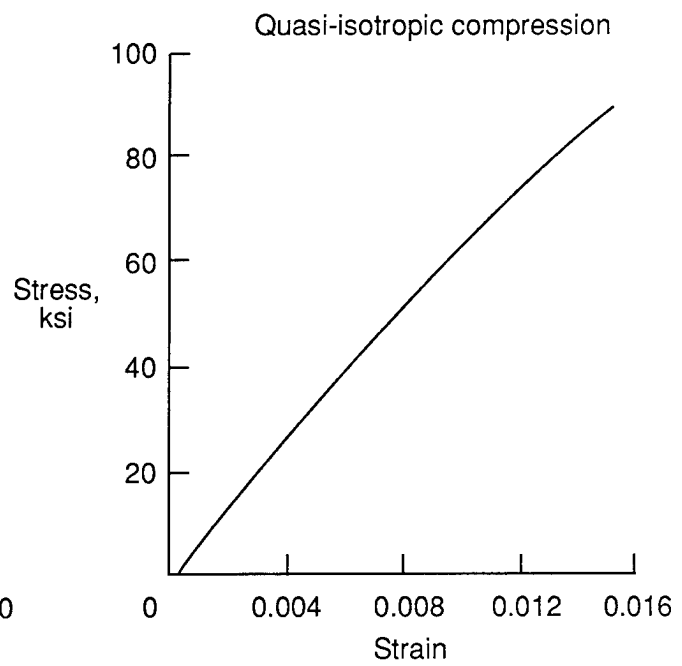
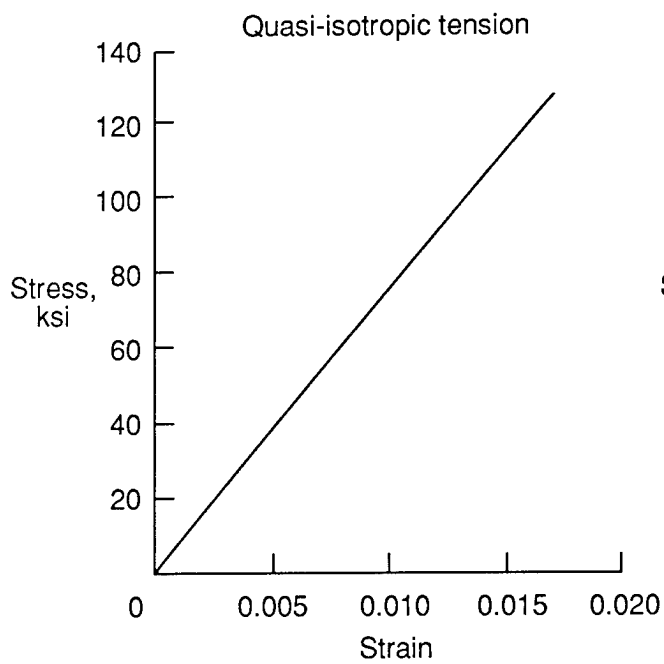
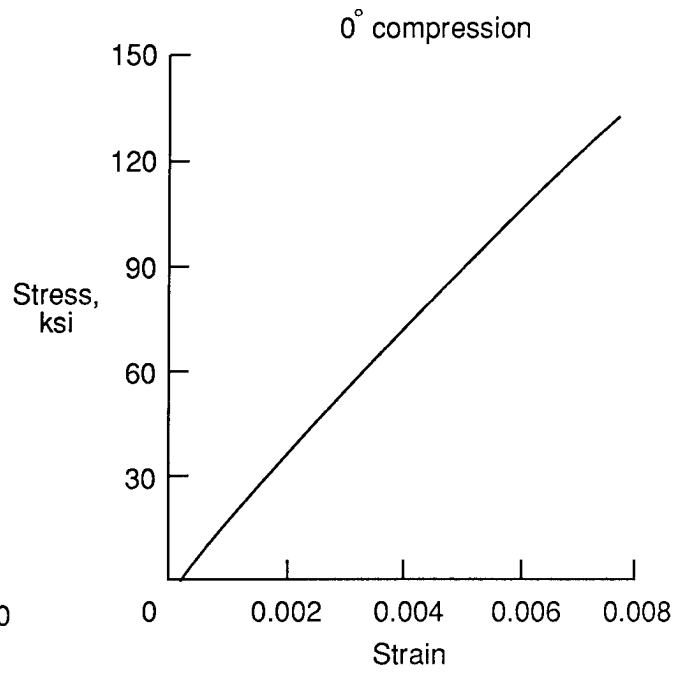
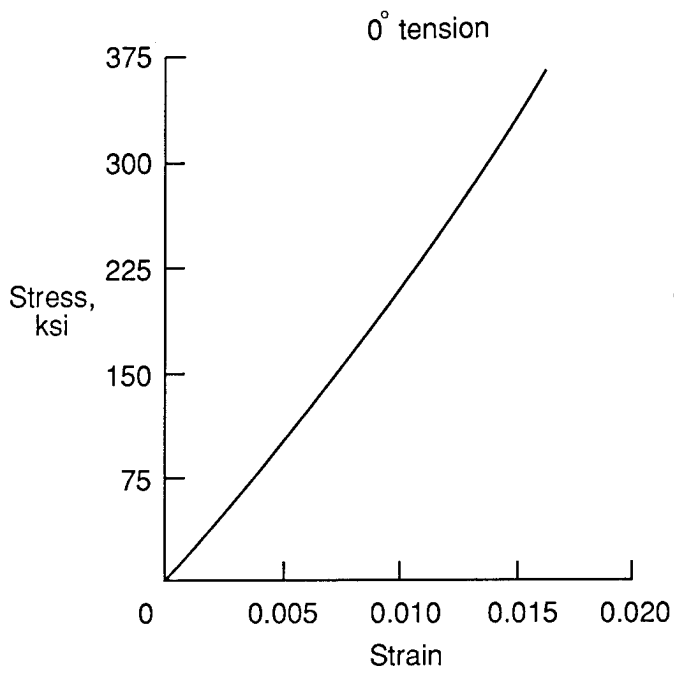

Figure 9. Typical stress-strain curves for IM7/8551-7 laminates.

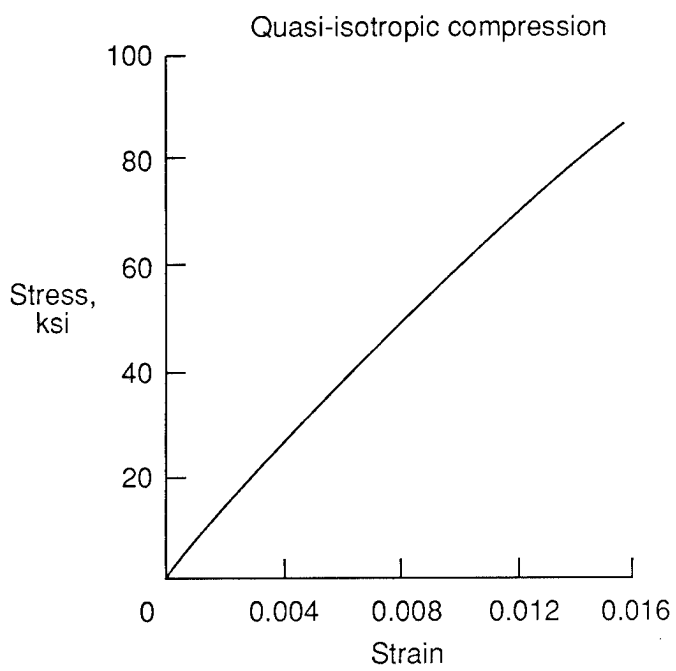
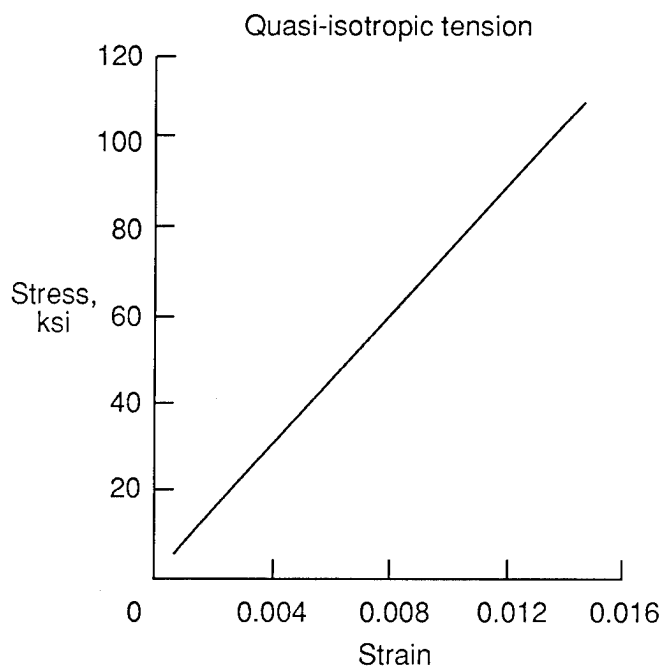
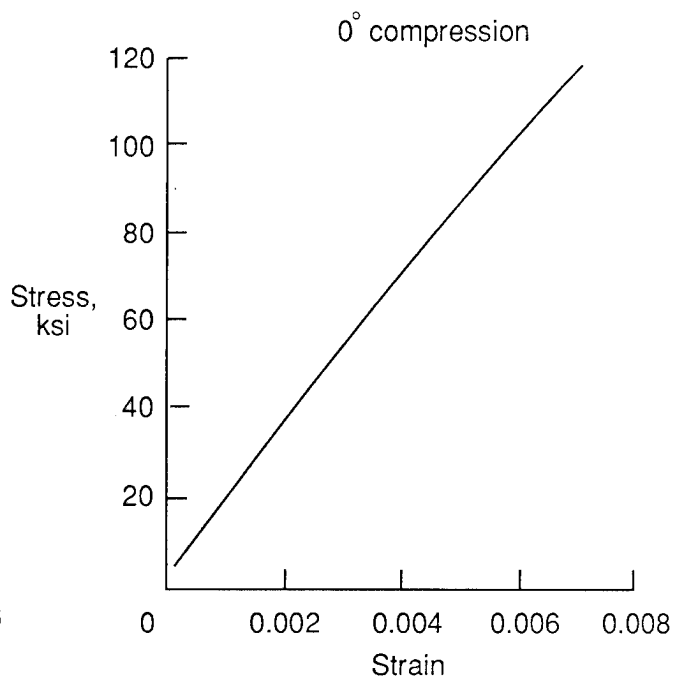
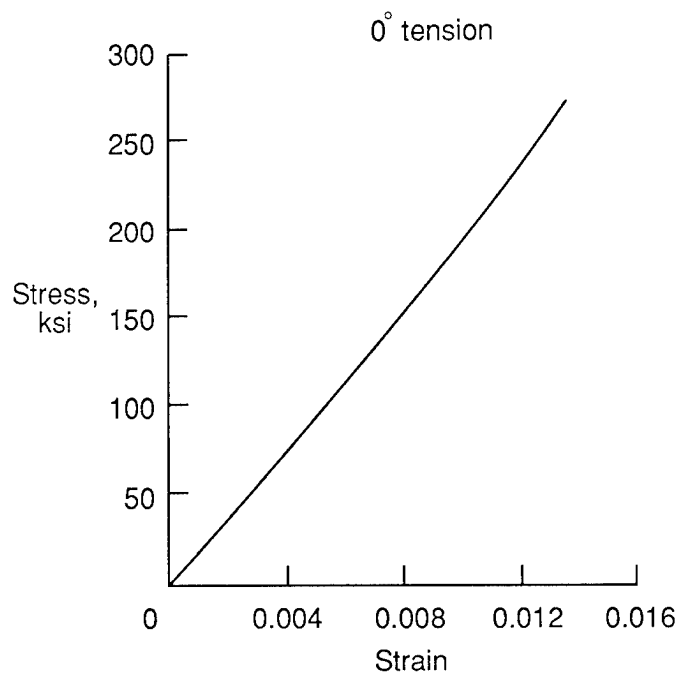
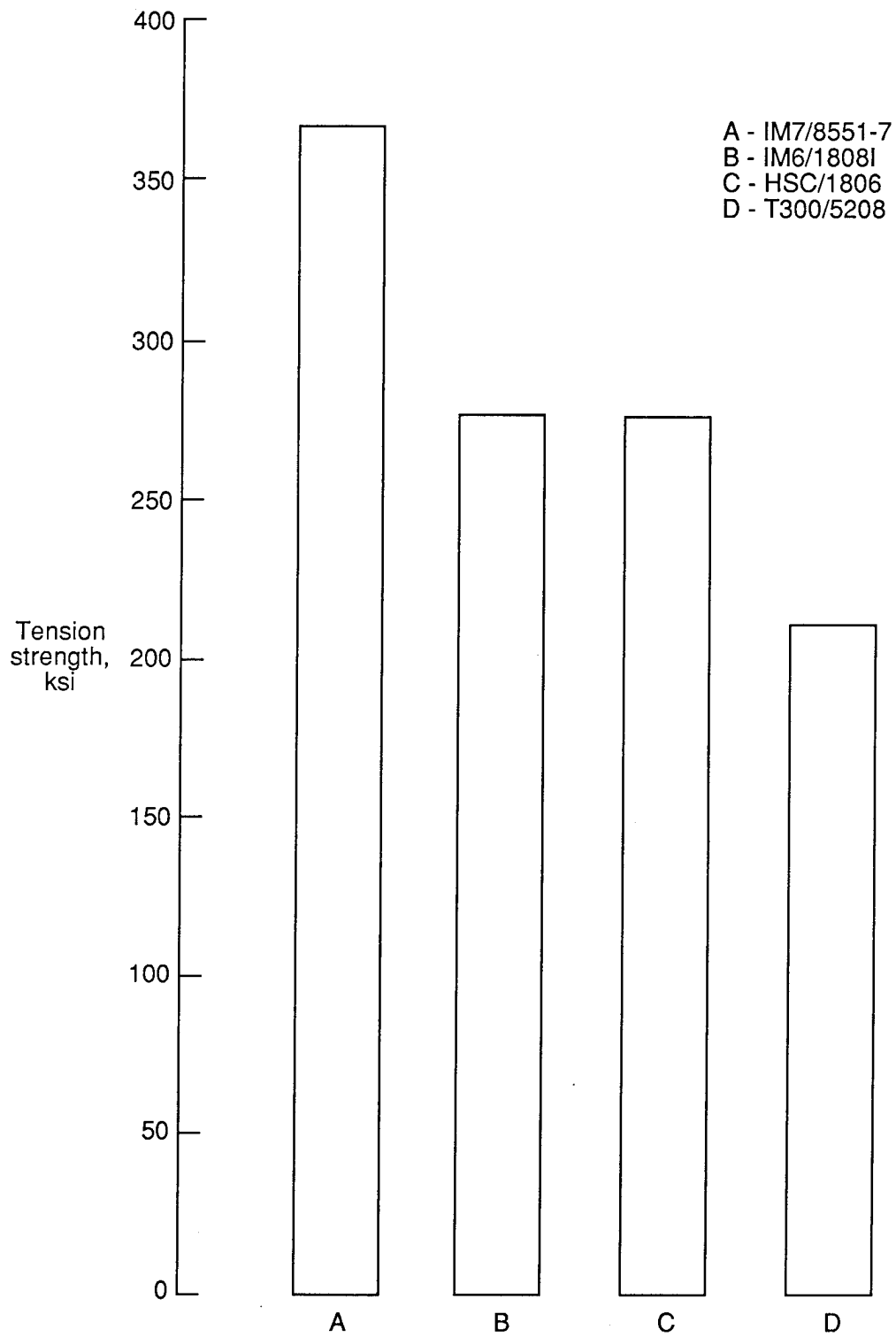
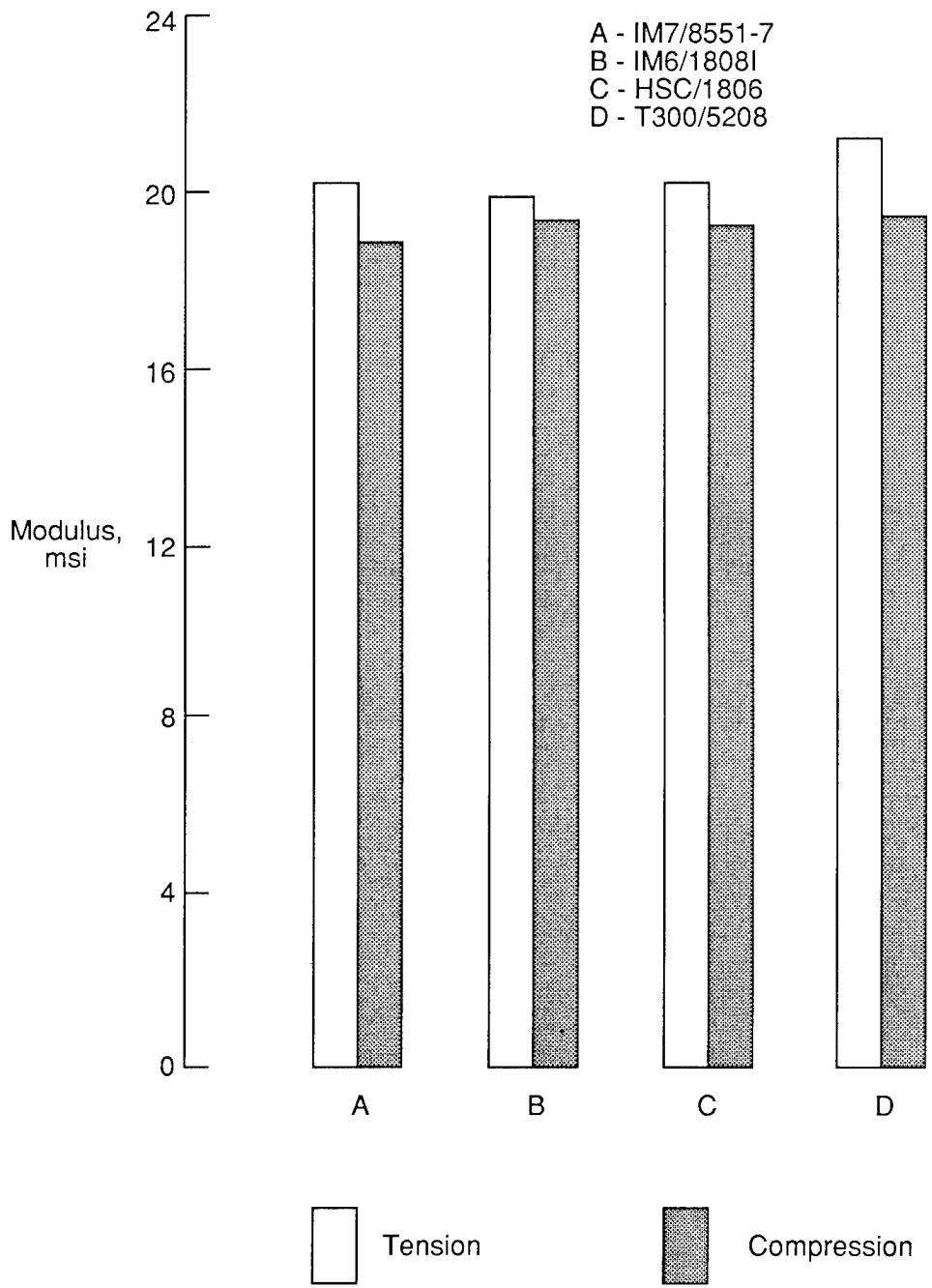

Figure 10. Typical stress-strain curves for IM6/1808I laminates.



(a) Ply level tension strength.

Figure 11. 0° strength and moduli.



(b) Tension and compression moduli.

Figure 11. Concluded.

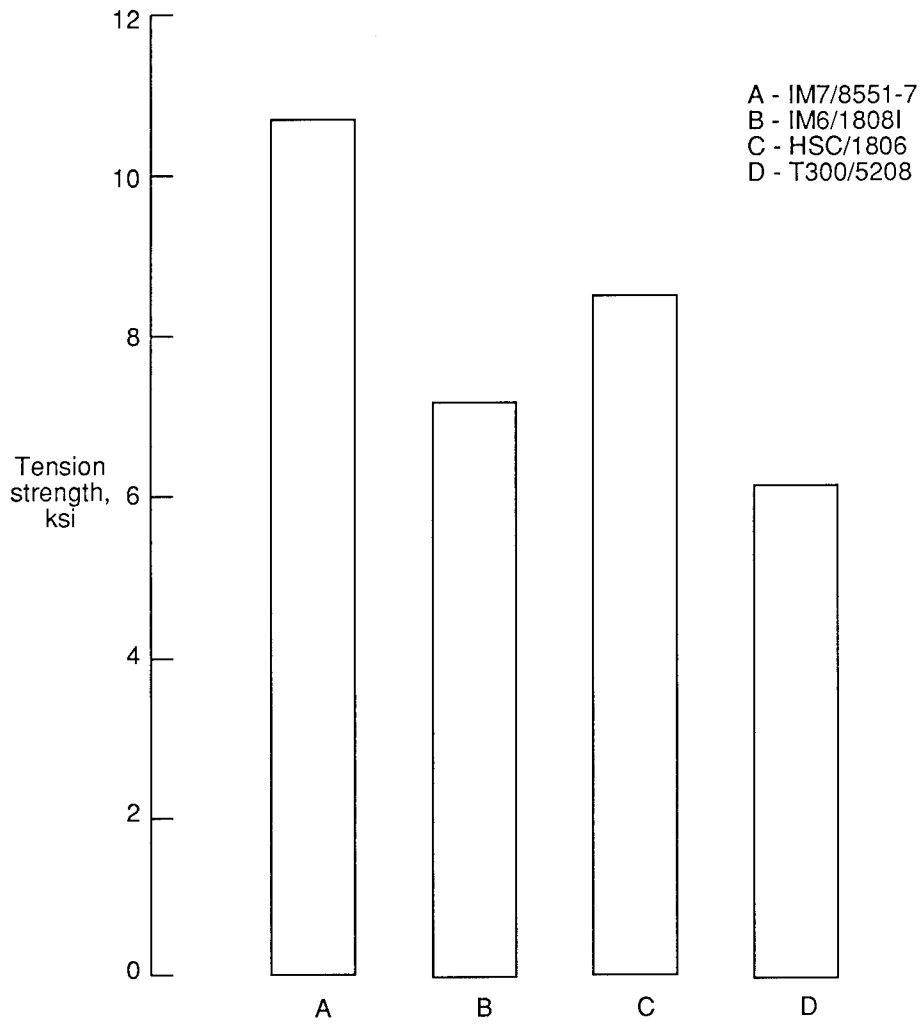

(a) Ply level tension strength.

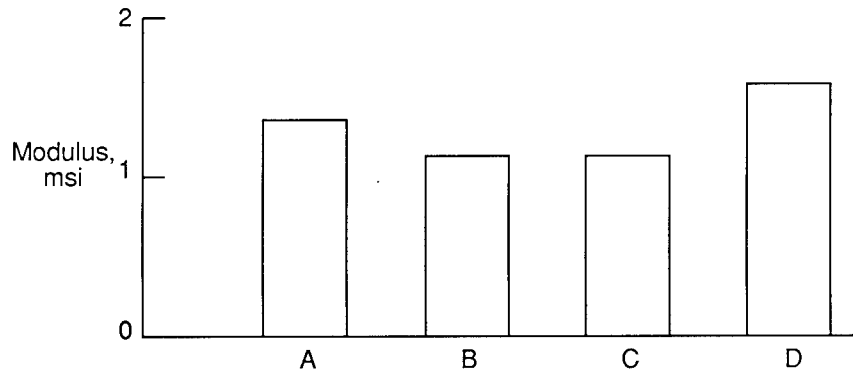

(b) Modulus.

Figure 12. 90° strength and modulus.

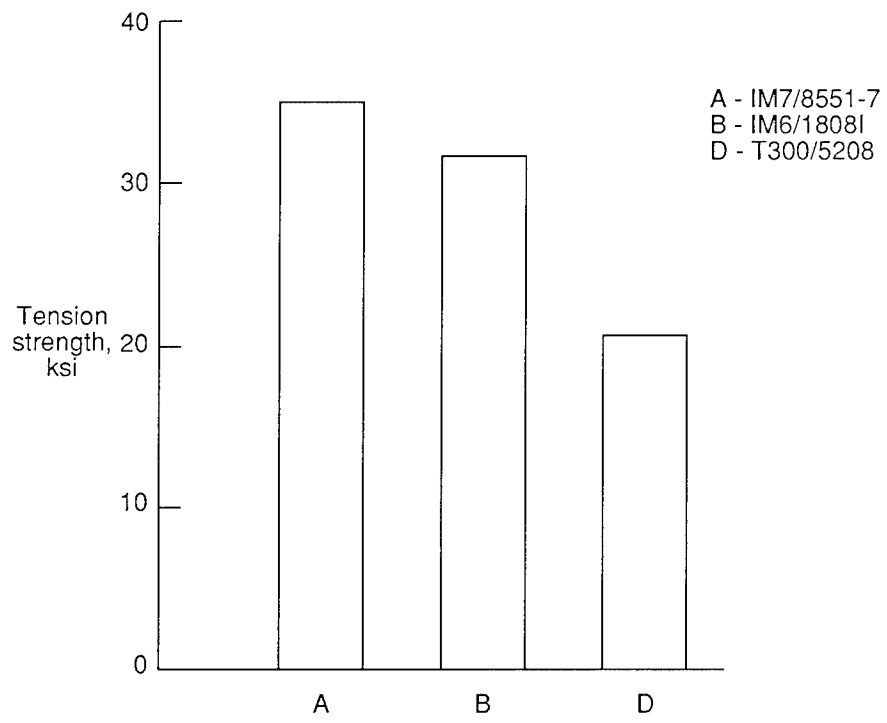

(a) Ply level tension strength.

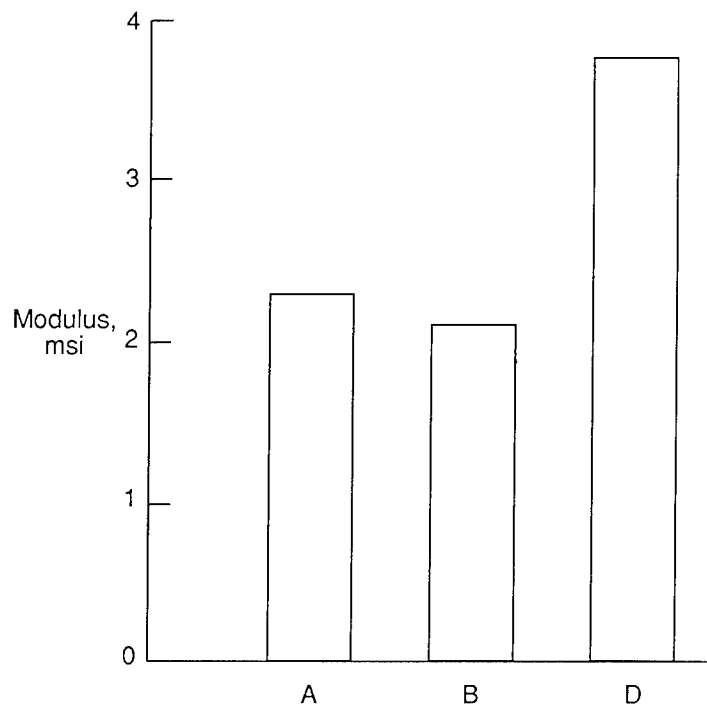

(b) Modulus.

Figure 13. $\pm 45^\circ$ strength and modulus.

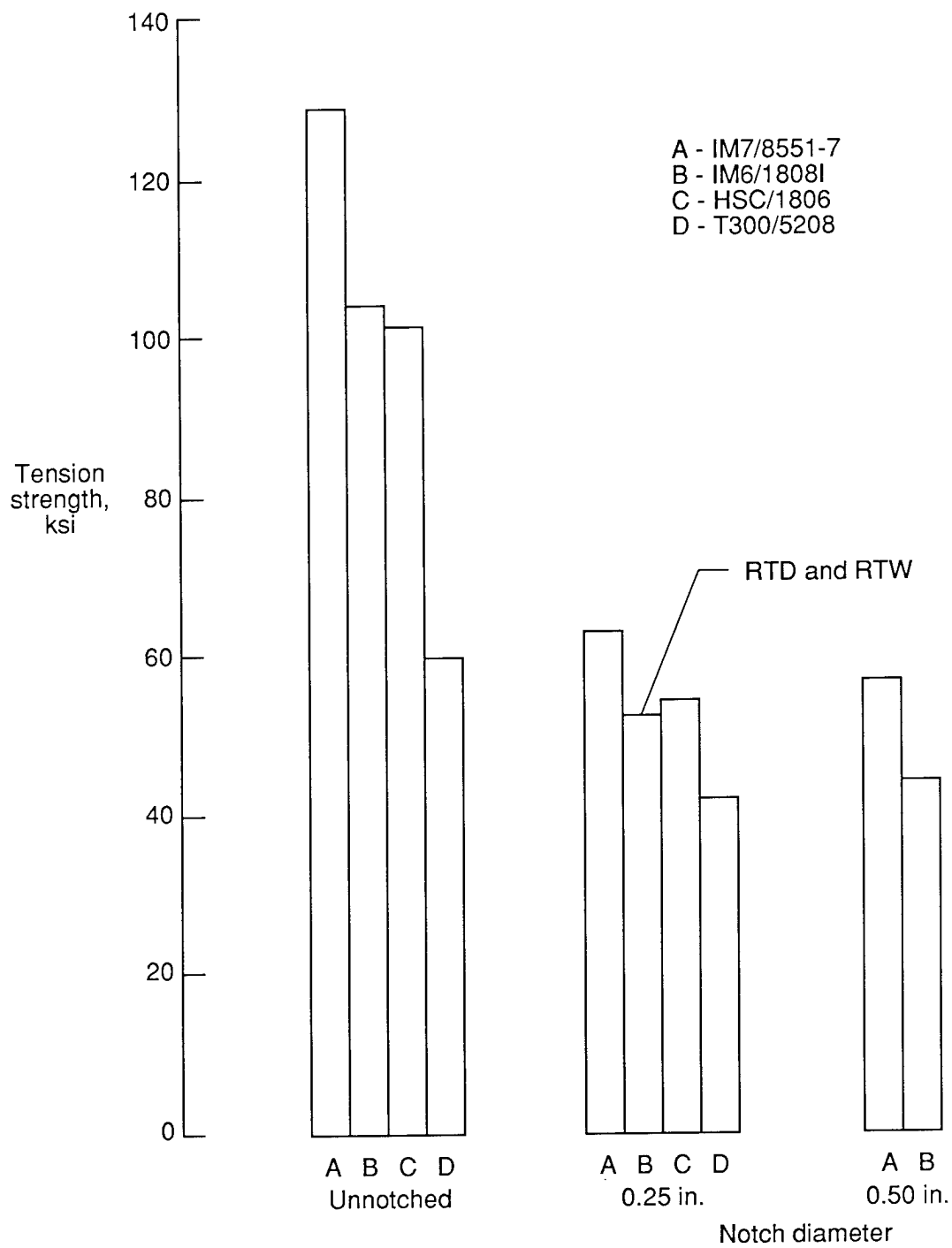

(a) Tension strength.

Figure 14. Tension strength and failure strain for unnotched and notched quasi-isotropic laminates.

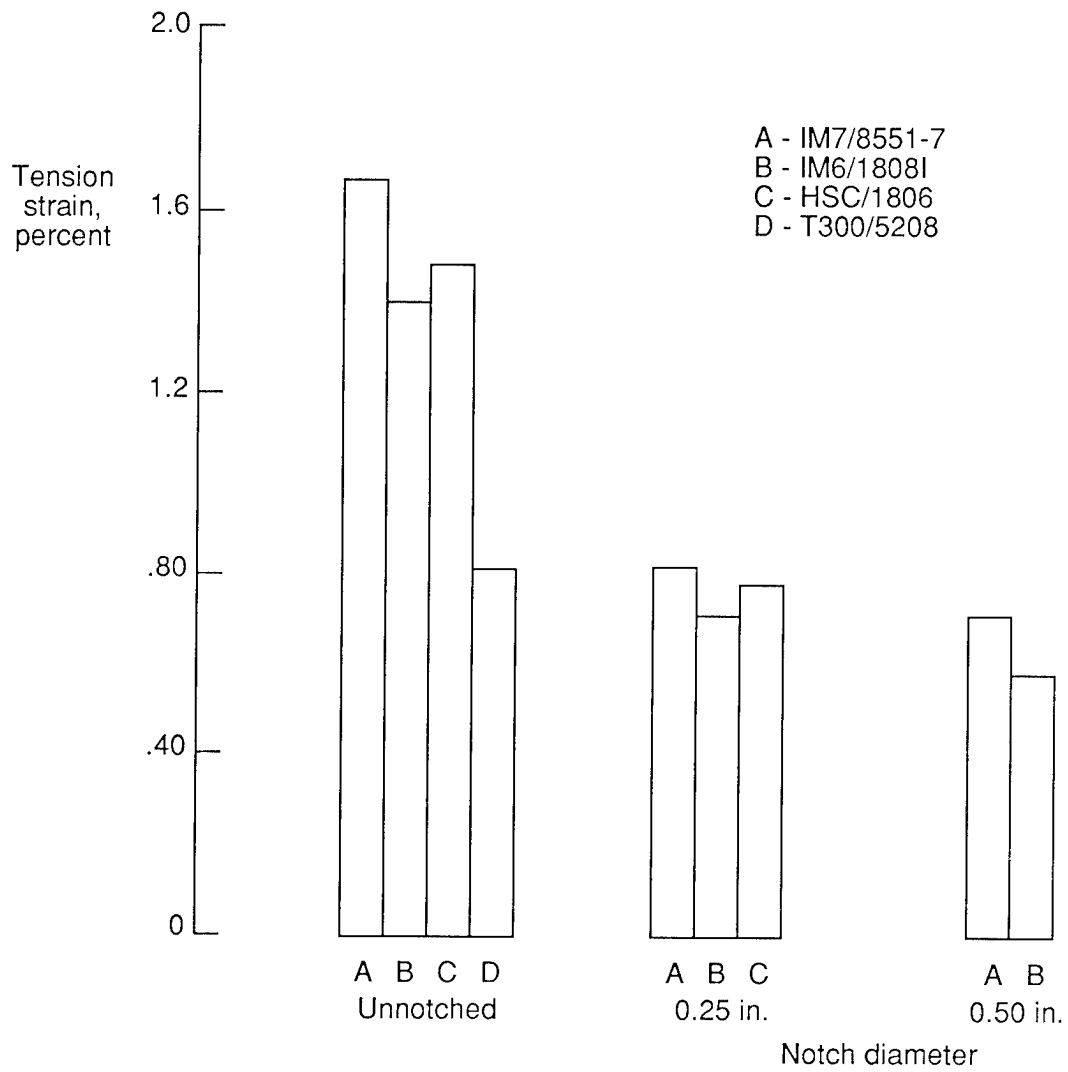

(b) Tension failure strain.

Figure 14. Concluded.

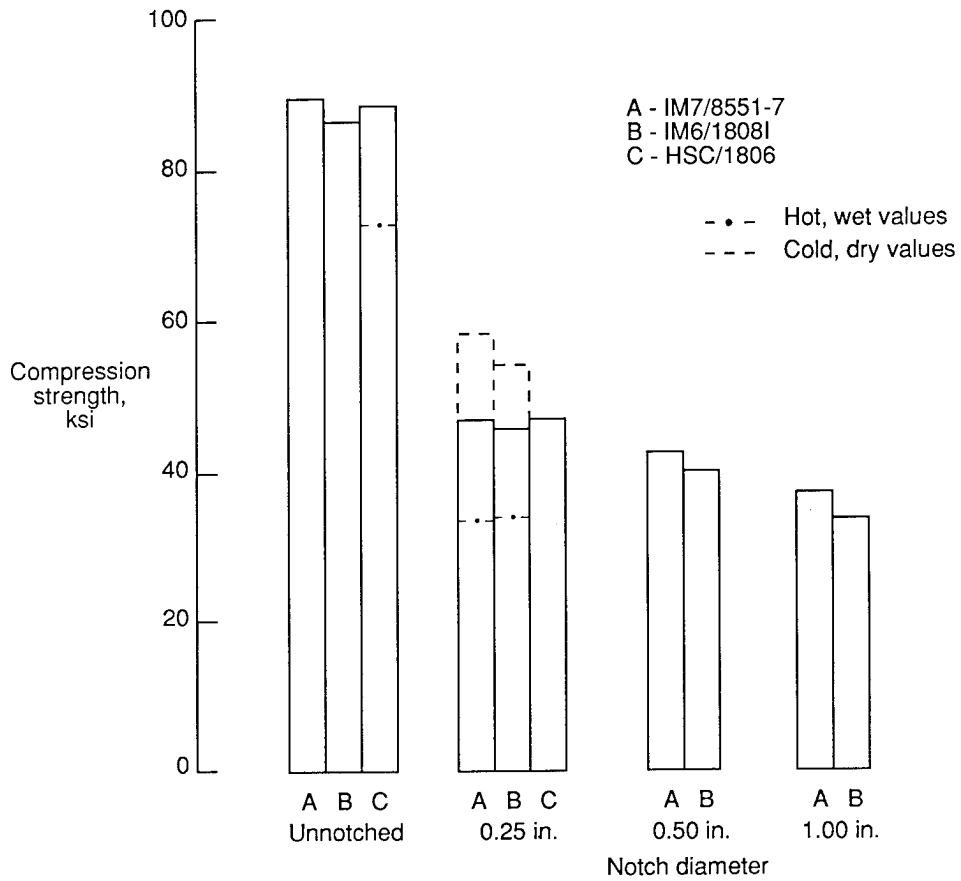

(a) Compression strength.

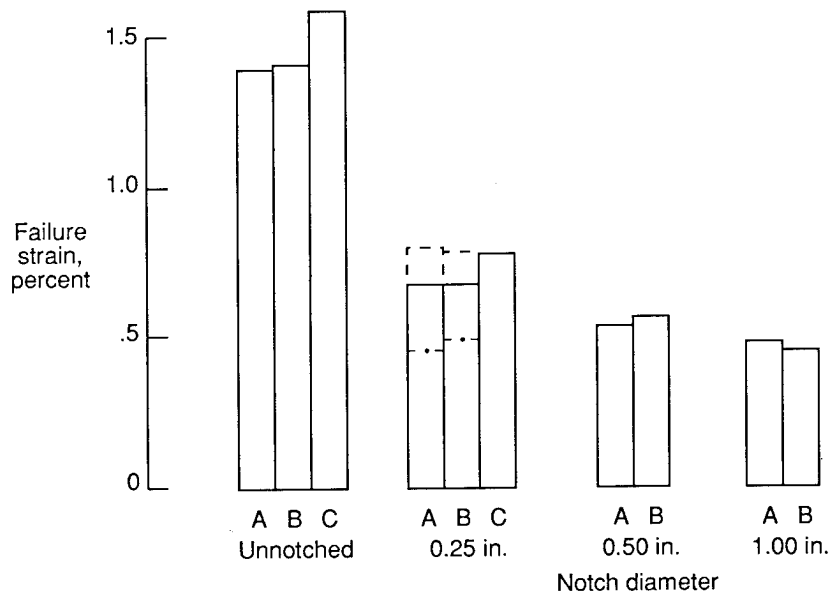

(b) Failure strain.

Figure 15. Compression strength and failure strain for unnotched and notched quasi-isotropic laminates.

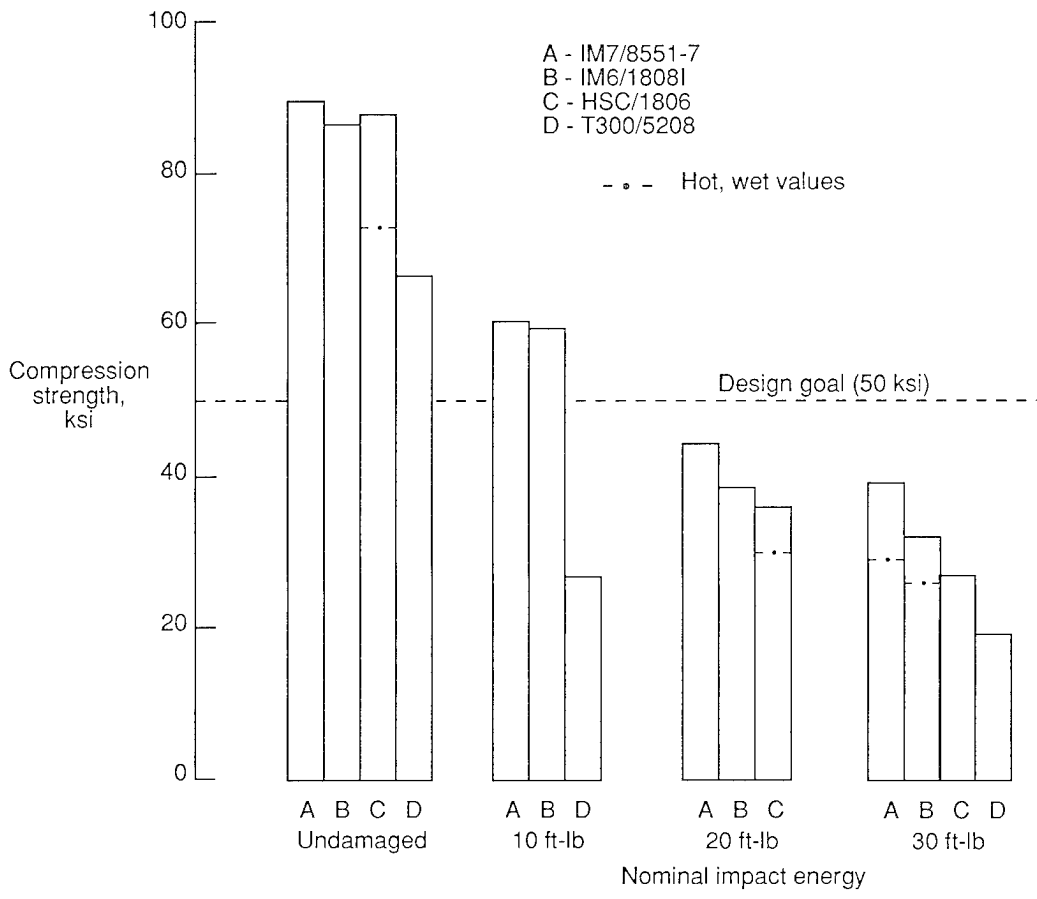

(a) Compression strength.

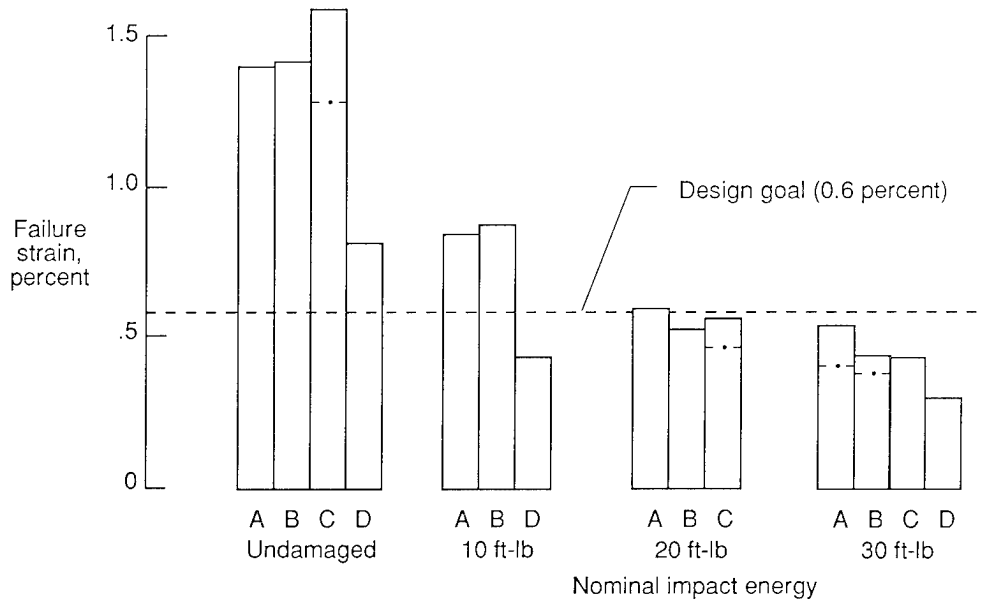

Figure 16. Compression strength and failure strain for impact-damaged quasi-isotropic laminates.



Report Documentation Page

1. Report No. NASA TP-2826	2. Government Accession No.	3. Recipient's Catalog No.	
4. Title and Subtitle Properties of Two Composite Materials Made of Toughened Epoxy Resin and High-Strain Graphite Fiber		5. Report Date July 1988	
		6. Performing Organization Code	
7. Author(s) Marvin B. Dow and Donald L. Smith		8. Performing Organization Report No. L-16425	
		10. Work Unit No. 505-63-01-06	
9. Performing Organization Name and Address NASA Langley Research Center Hampton, VA 23665-5225		11. Contract or Grant No.	
		13. Type of Report and Period Covered Technical Paper	
12. Sponsoring Agency Name and Address National Aeronautics and Space Administration Washington, DC 20546-0001		14. Sponsoring Agency Code	
		15. Supplementary Notes Marvin B. Dow: Langley Research Center, Hampton, Virginia. Donald L. Smith: Planning Research Corporation, Hampton, Virginia.	
16. Abstract Results are presented from an experimental evaluation of IM7/8551-7 and IM6/1808I, two new composite materials made of toughened epoxy resin and high-strain graphite fibers. Data include ply level strengths and moduli, notched tension and compression strengths, and compression-after-impact assessments. The measured properties are compared with those of other graphite-epoxy materials. Specimen fabrication and testing were performed at the NASA Langley Research Center.			
17. Key Words (Suggested by Authors(s)) Ply level strengths Notched tension Compression strengths Compression after impact High-strain graphite fiber composite materials		18. Distribution Statement Unclassified—Unlimited Subject Category 24	
19. Security Classif.(of this report) Unclassified	20. Security Classif.(of this page) Unclassified	21. No. of Pages 41	22. Price A03