

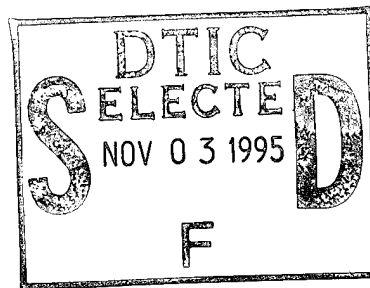

Multiplexers for Multifunction Electromagnetic Radiating Systems (MERS)

W. Henry T. Q. Ho M. Mills D. Rubin

Technical Document 2852
September 1995



Naval Command, Control and
Ocean Surveillance Center
RDT&E Division

San Diego, CA
92152-5001

19951101 142

QUALITY INSPECTED 8



Technical Document 2852
September 1995

Multiplexers for Multifunction Electromagnetic Radiating Systems (MERS)

W. Henry
T. Q. Ho
M. Mills
D. Rubin

Accession For	
NTIS	CRARI <input checked="" type="checkbox"/>
DTIC	TAB <input type="checkbox"/>
Unannounced <input type="checkbox"/>	
Justification	
By	
Distribution /	
Availability Codes	
Dist	Avail and/or Special
A-1	

**NAVAL COMMAND, CONTROL AND
OCEAN SURVEILLANCE CENTER
RDT&E DIVISION
San Diego, California 92152-5001**

K. E. EVANS, CAPT, USN
Commanding Officer

R. T. SHEARER
Executive Director

ADMINISTRATIVE INFORMATION

The work detailed in this report was performed for the Office of Naval Research by the Naval Command, Control and Ocean Surveillance Center, RDT&E Division, Applied Electromagnetics Branch, Code 822. Funding was provided under Program Element 0602232N, Accession Number DN305458.

Released by
L. C. Russell, Head
Applied Electromagnetics Branch

Under authority of
R. J. Kochanski, Head
Communications Systems
Engineering and Integration
Division

CONTENTS

1.	INTRODUCTION	1
2.	MULTIPLEXER ARCHITECTURE	1
2.1	SYSTEM CONCEPT	1
2.2	MULTIPLEXER REQUIREMENTS	3
2.3	DESIGN CONSIDERATIONS	3
2.3.1	Low-Pass and High-Pass Filters	4
2.3.2	Band-Pass Filters	5
2.3.3	High-Pass and Low-Pass Multiplexers	5
2.3.4	Filter Design Using Parallel Resonators	6
3.	NUMERICAL RESULTS	6
4.	RECOMMENDATIONS AND CONCLUSIONS	14
5.	REFERENCES	14
APPENDIX A		A-1
APPENDIX B		B-1

Figures

1.	MERS system architecture	2
2.	Ladder network for π configuration	4
3.	Ladder network for T configuration	4
4.	Configuration for low-pass filter	5
5.	Configuration for high-pass filter	5
6.	UHF/JTIDS multiplexer	7
7.	Performance for UHF/JTIDS multiplexer	8
8.	IFF multiplexer schematic	10
9.	IFF multiplexer performance	11
10.	Combat DF multiplexer circuit diagram	12
11.	Combat DF multiplexer performance trend	13
A-1.	Transformation from low-pass to band-pass	A-1
A-2.	Dual circuits for band-pass transformation	A-1
B-1.	Transformation from series/parallel LC band-pass to capacitively coupled quarter-wave shorted lines	B-2
B-2.	Procedure for realizing inductive coupling between resonators	B-3

Tables

1.	CDF multiplexer requirements	3
2.	UHF/JTIDS multiplexer requirements	3
3.	TxRx multiplexer requirements	3

1. INTRODUCTION

The Multiplexers for Multifunction Electromagnetic Radiating Systems (MERS) objective was to merge four different radio frequency (RF) sensor systems into a single-antenna structure. Currently, the four candidates are Combat Direction Finding (CDF), Identification Friend or Foe (IFF), Joint Tactical Information Distribution System (JTIDS), and Ultra-High-Frequency (UHF) communications. This report demonstrates that the merged antenna system is a low-cost system that decreases topside space and weight requirements while it also improves the multiple system performance. The ultimate goal is to provide a family of MERS antennas that meet each ship class antenna requirement in a combined and optimized structure.

MERS requires appropriate isolation between different systems to function properly. Multiplexing networks is one isolation method. Generally, a multiplexer can divide a frequency band into two separate bands or frequency packets. MERS requires several multiplexers to separate the Very-High-Frequency (VHF) portion of the CDF from the UHF, UHF communications from JTIDS, and IFF transmission from receiving signals. This report focuses on these multiplexers. The designs are preliminary. This report discusses the requirements, system concept for MERS, theoretical aspects, and the numerical results behind the multiplexer designs. Recommendations for future work are also included.

2. MULTIPLEXER ARCHITECTURE

2.1 SYSTEM CONCEPT

Figure 1 shows the proposed MERS architecture. The MERS concept mirrors the struggle to eliminate "stove pipe" systems and replace them with shared assets. In this report, the shared assets are antennas, RF amplifiers, control and RF distribution systems. There are three principal elements to the MERS concept:

1. Circular array antenna
2. Wideband UHF communications architecture
3. Fiber-optic control and RF distribution system

The circular arrays antenna will consist of three low-profile antenna arrays that encircle the mast one above the other. The systems are combined such that JTIDS and UHF communications operate on the upper array, the Combat Direction Finder (CDF) operates on the middle array, and the IFF operates on the lower array. Three circular sets allow concurrent operation of all four systems and yet provide adequate isolation for electromagnetic interference (EMI) control. These arrays provide simultaneous transmit and receive capability, omnidirectional coverage, and directional coverage when required.

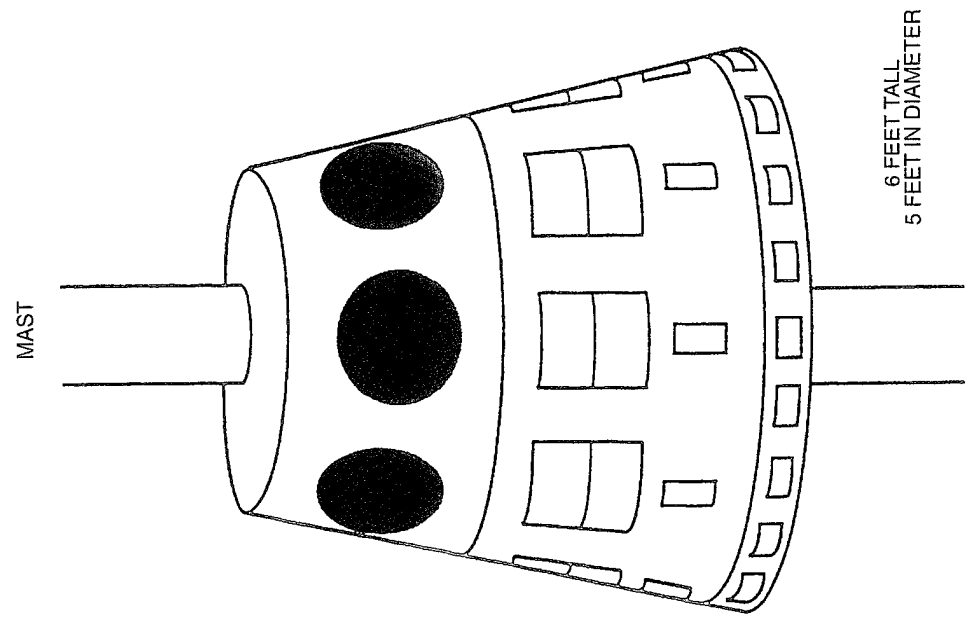
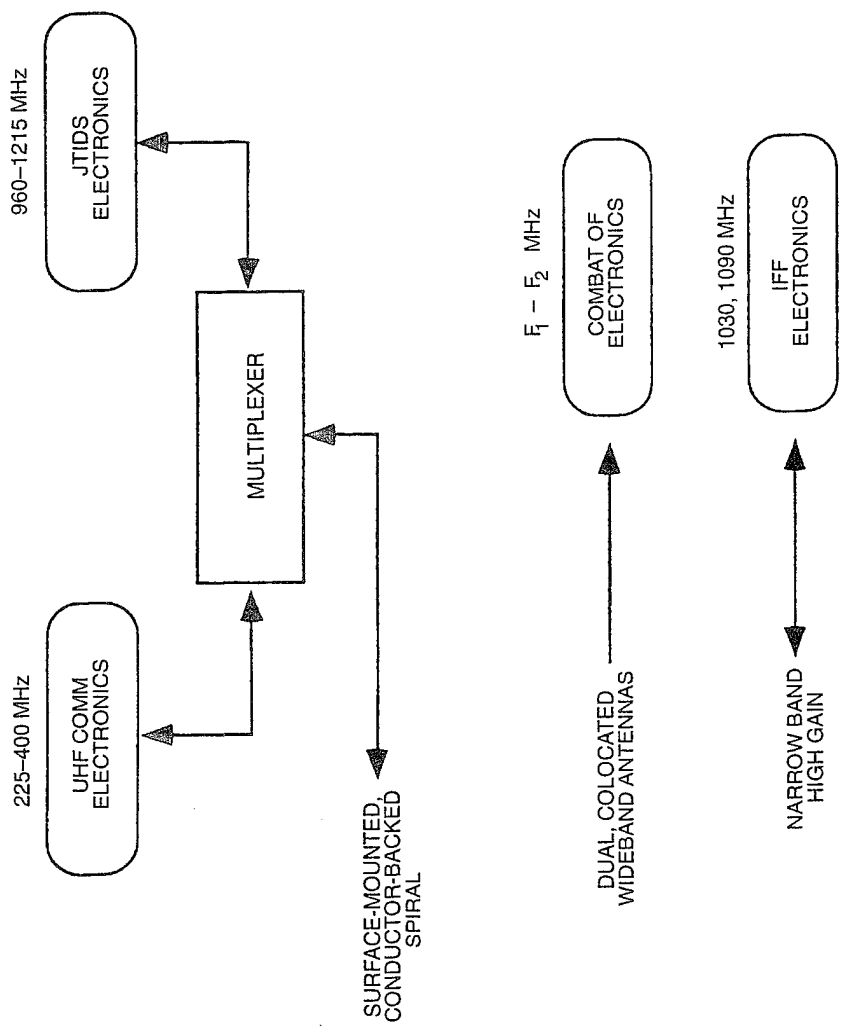

Figure 1. MERS system architecture.

2.2 MULTIPLEXER REQUIREMENTS

As discussed previously, multiplexers will be used to provide isolation between different systems. The preliminary requirements for these multiplexers are described as follows:

The CDF Multiplexer separates the VHF portion of the CDF from the UHF portion. Table 1 describes the requirements for this multiplexer.

Table 1. CDF multiplexer requirements.

Characteristics	Capability Requirement
VHF Band	$F_1 - F_2$
UHF Band	$F_3 - F_4$
Insertion Loss	0.5 dB
Isolation	≥ 80 dB
VSWR	1.5:1
Power Rating	1 kW

The UHF/JTIDS Multiplexer separates UHF communications from JTIDS. Table 2 describes the requirements for this multiplexer.

Table 2. UHF/JTIDS multiplexer requirements.

Characteristics	Capability Requirement
UHF Band	225-400 MHz
JTIDS Band	960-1215 MHz
Insertion Loss	0.5 dB
Isolation	≥ 80 dB
voltage standing-wave ratio (VSWR)	1.4:1
Power Rating	10 kW

The T_X/R_X IFF Multiplexer separates the IFF reception from transmission. Table 3 describes the requirements for this multiplexer.

Table 3. T_X/R_X multiplexer requirements.

Characteristics	Capability Requirement
Transmission Band	1030 MHz
Reception Band	1090 MHz
Insertion Loss	0.5 dB
Isolation	≥ 80 dB
VSWR	1.4:1
Power Rating	10 kW

2.3 DESIGN CONSIDERATIONS

The first two multiplexers are designed with lumped elements, while the last multiplexer uses coaxial line resonators. These multiplexers use Chebyshev designs. Ladder networks can be either a π or T configuration. Figure 2 shows the π configuration type. Figure 3 shows the T configuration type.

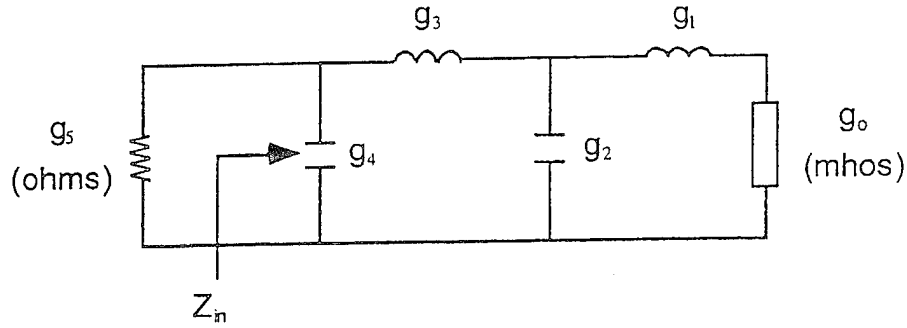

Figure 2. Ladder network for π configuration.

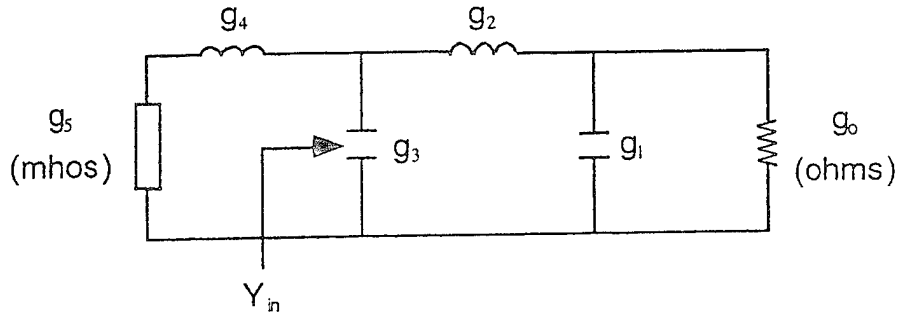

Figure 3. Ladder network for T configuration.

The circuit parameters can be computed as follows (Matthaei, Young & Jones, 1964):

$$X = \frac{1}{2N} \cdot \ln \left[\coth \left(\frac{R}{17.37} \right) \right] \quad (1)$$

$$a_k = \sin \left[(2K - 1) \frac{\pi}{2N} \right] \quad K = 1, 2, 3, \dots, N \quad (2)$$

$$b_k = \sinh^2(x) + \sin^2 \left(\frac{K\pi}{N} \right) \quad (3)$$

$$g_1 = \frac{2a_1}{\sinh(x)} \quad (4)$$

$$\text{for } K=2 \text{ to } N \quad g_k = 4 \left[\frac{a_{K-1} \cdot a_K}{b_{K-1} \cdot g_{K-1}} \right] \quad (5)$$

$$\text{for } N \text{ odd } \dots \quad g_{N+1} = 1 \quad (6)$$

$$\text{for } N \text{ even } \dots \quad g_{N+1} = \coth^2 \left(\frac{Nx}{2} \right) \quad (7)$$

where $R = \text{ripple (dB)}$, $g_0 = 1$, and $N = \text{the number of reactive elements}$. These two ladder networks are “duals” of each other. This is because the equations for the input impedance (first element capacitor) and conductance (first element inductor) give identical reflection coefficients and therefore, the same transmission for purely reactive circuits.

2.3.1 Low-Pass and High-Pass Filters

Designing a low-pass filter simply involves changing the g values to conform with the actual impedance of the source. For a high-pass filter, we may use $1/g$ values and change series inductors to

capacitors and parallel capacitors to inductors. Figure 4 shows the configuration for a low-pass filter and figure 5 shows the configuration for a high-pass filter.

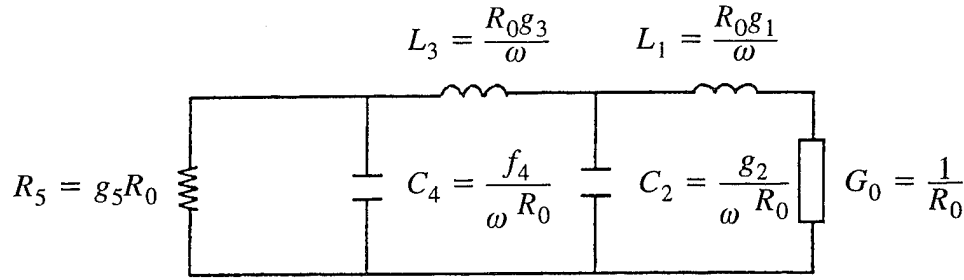

Figure 4. Configuration for low-pass filter.

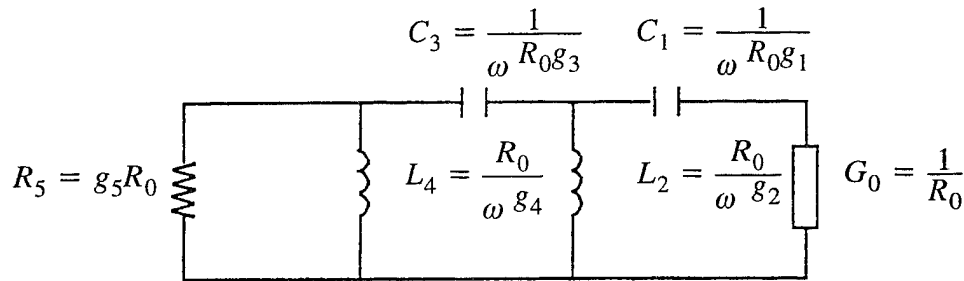

Figure 5. Configuration for high-pass filter.

2.3.2 Band-Pass Filters

For a band-pass filter, NRaD researchers used the following technique by first changing the prototype from series inductors to series latch-checking (LC) circuits that resonate at ω_0 . The values were computed as follows:

$$L_K = \frac{g_K R_0}{\omega_0 W}, C_K = \frac{1}{\omega_0^2 L_K}, W = \frac{BW}{f_0}, \quad (8)$$

with BW representing the filter's bandwidth. Next the researchers changed the prototype parallel capacitances to parallel LC circuits that resonate at ω_0 ,

$$C_J = \frac{g_J}{\omega_0 W R_0} \quad \text{and} \quad L_J = \frac{1}{\omega_0^2 C_J}. \quad (9)$$

Appendix A provides proof of this method.

2.3.3 High-Pass and Low-Pass Multiplexers

If low-pass and high-pass filters are used to design a multiplexer, the input impedance must be directly matched into the source. The impedance presented to the source will be the parallel combination of the two filters. At each frequency, the current through one filter is dependent on the impedance presented by the other. One may design high-pass and low-pass multiplexers using g values for low-pass prototypes with a source impedance of zero ohms. In this case, the current through each filter is independent of the other in order to maintain the Chebyshev or Butterworth characteristics. If source impedance equal to the load impedance is now used, the voltage at the junction will be

approximately half the source voltage. This results in the equal-ripple or maximally flat responses maintained for each filter.

A multiplexer formed by high-pass and low-pass maximally flat filters will yield a 3-dB crossover with excellent VSWR throughout the designated bandwidth. In practice, filters are not lossless, therefore, the crossover attenuation will be slightly higher than 3 dB. In the case of Chebyshev filters, the cutoff slopes are much steeper for the same number of elements, and therefore, these configurations are common. The corresponding equations for Chebyshev singly connected prototypes are given in Matthaei et al. (1964).

$$\beta = \ln \left[\coth \frac{R}{17.37} \right], \quad \gamma = \sinh \left(\frac{\beta}{2N} \right) \quad (10)$$

$$a_K = \sin \left[\frac{\pi(2K-1)}{2N} \right], \quad K = 1, 2, \dots, N \quad (11)$$

$$d_K = \left[Y^2 + \sin^2 \left(\frac{\pi K}{2N} \right) \right] \cos^2 \left(\frac{\pi K}{2N} \right), \quad K = 1, 2, \dots, N-1 \quad (12)$$

$$g_1 = \frac{a_1}{r}, \quad g_{N+1} = \infty \quad (13)$$

$$g_K = \frac{a_K a_{K-1}}{d_{K-1} g_{K-1}}, \quad K = 1, 2, \dots, N \quad (14)$$

2.3.4 Filter Design Using Parallel Resonators

Most microwave circuits use either series or parallel resonators but not both. A short-circuited coaxial cable line acts like a parallel LC circuit near its quarter wavelength center frequency. Excellent filters with bandwidths less than 20 percent can be obtained using these resonators coupled with either inductors or capacitors. The two popular inverters use π connections of either inductors or capacitors. These elements behave as ideal inverters, especially near the center frequency, as can easily be shown using ABCD matrices. Appendix B describes the steps necessary to go from series parallel LC band-pass filters to capacitive coupled quarter-wave shorted lines (Sagawa, Makimoto, & Yamashita, 1985).

3. NUMERICAL RESULTS

This section presents circuit diagram and performance data for the multiplexers. Figure 6 shows a schematic of the UHF/JTIDS multiplexer. As mentioned before, the UHF/JTIDS multiplexer separates the UHF communications from JTIDS signals. The UHF band is from 225 to 400 MHz, and the JTIDS band is from 960 to 1215 MHz. The design consists of one high-pass filter, one low-pass filter, and two band-pass filters. The low-pass filter passes all frequencies below 620 MHz. These frequencies are then passed through a band-pass filter that coincides with the UHF bandwidth. The high-pass filter passes frequencies greater than 620 MHz. These frequencies are then passed through a band-pass filter coinciding with the JTIDS bandwidth. Figure 7 shows the numerical data of the UHF/JTIDS multiplexer. The plot shows the insertion loss as a function of frequency. Insertion loss is the loss of power in a load that occurs when a network is inserted between the load and generator supplying the load. The numerical data show the design has about 0.2-dB insertion loss and more than 80-dB isolation between the two systems.

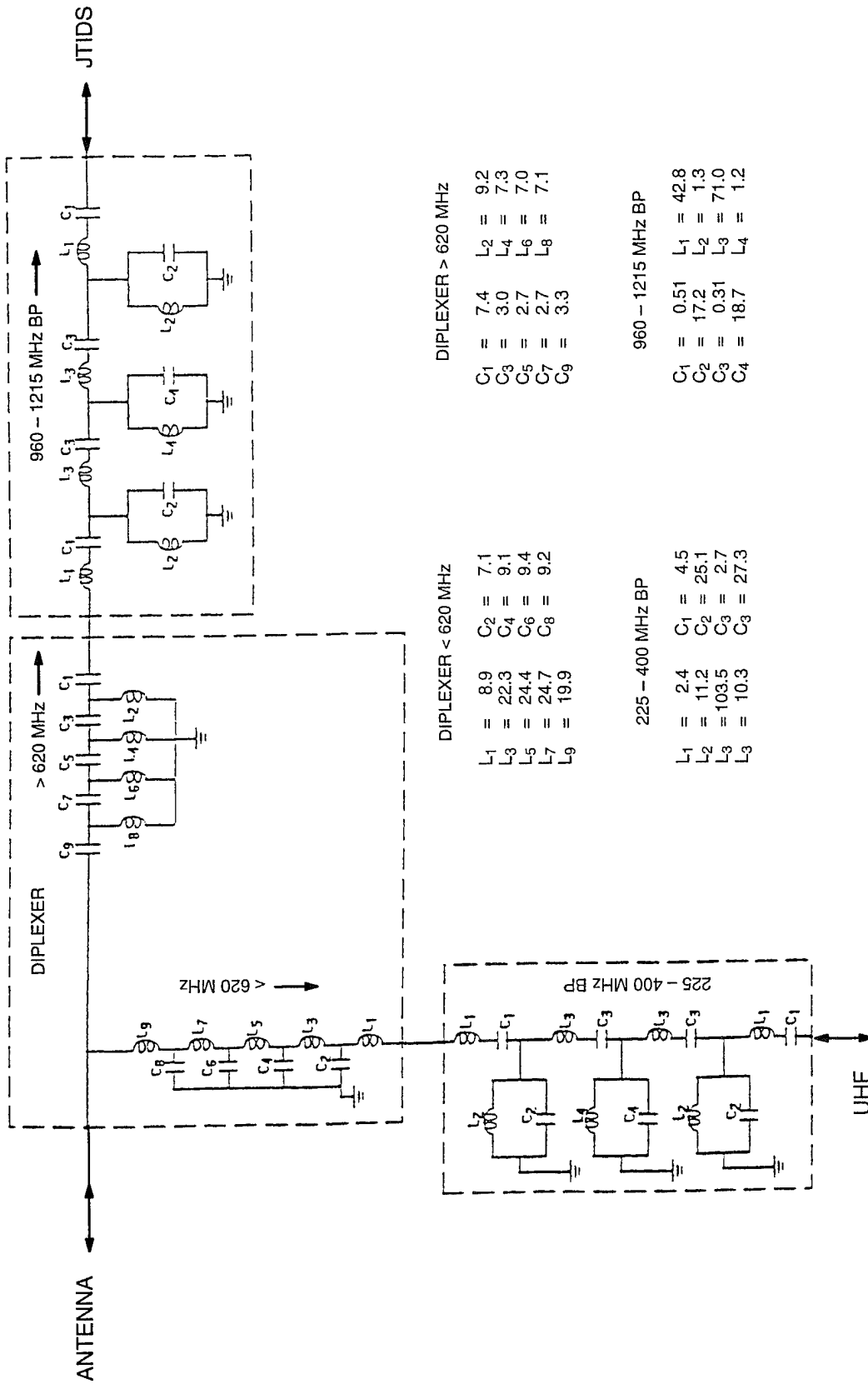

Figure 6. UHF/JTIDS multiplexer.

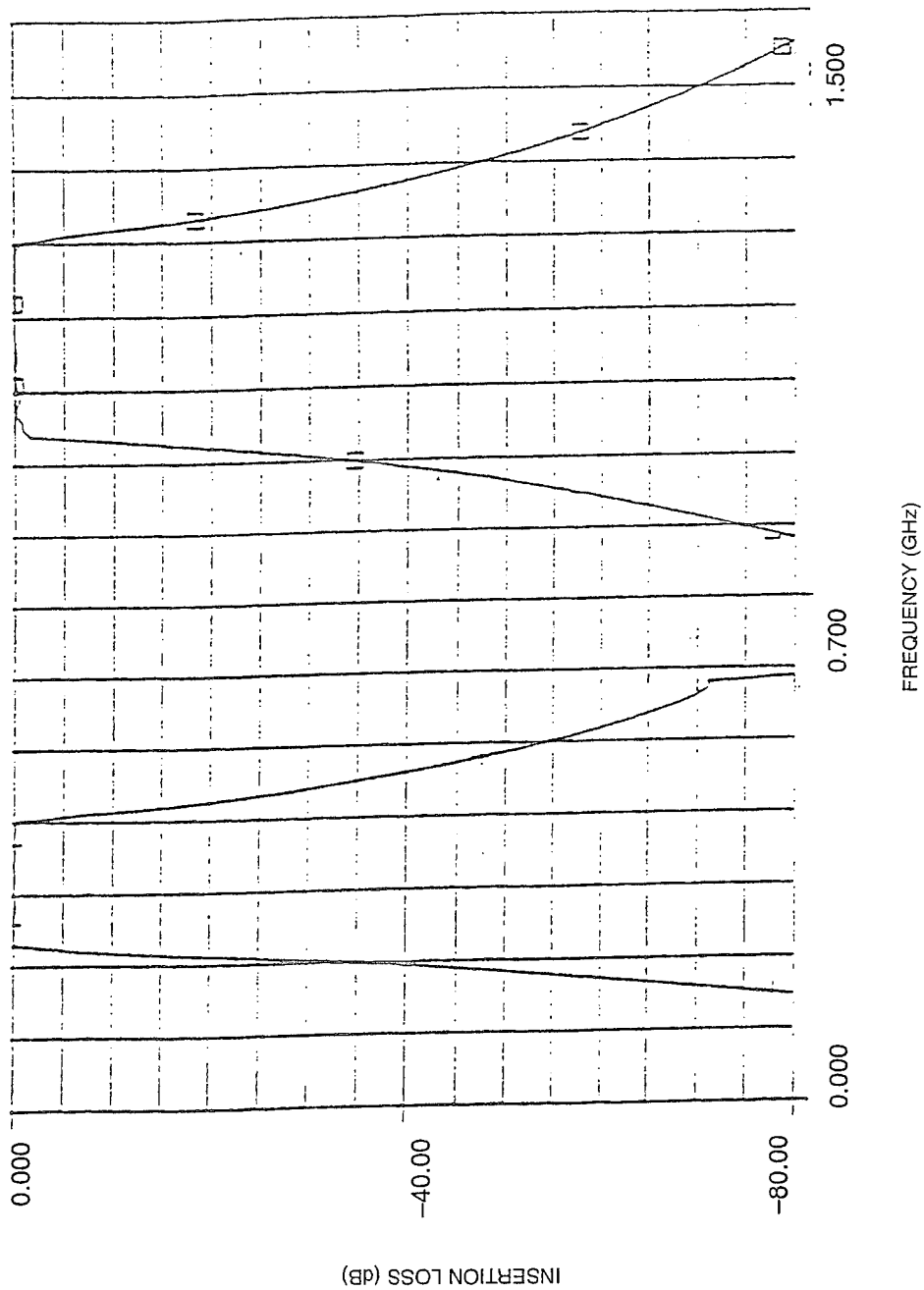

Figure 7. Performance for UHF/JTIDS multiplexer.

The IFF multiplexer has a much narrower bandwidth than the UHF/JTIDS multiplexer. In this case the multiplexer separates IFF transmission and receiving signals. The transmission bandwidth is from 1025 to 1035 MHz, and the bandwidth for receiving is from 1085 to 1095 MHz. Figure 8 shows the schematic of the IFF multiplexer while figure 9 shows the performance. As illustrated, the insertion loss is about 0.1 dB in the passbands, and isolation is more than 80 dB between the transmitter and the receiver. In this design, the passbands are 1025 to 1035 MHz and 1085 to 1095 MHz.

Figure 10 shows the proposed circuit diagram for the Combat DF multiplexer. The operating frequencies for the Combat DF are classified, therefore, they will not be discussed here. However, the design is made up of two high-pass filters, one low-pass filter, and one band-pass filter. Figure 11 shows the trend for the frequency response of this multiplexer.

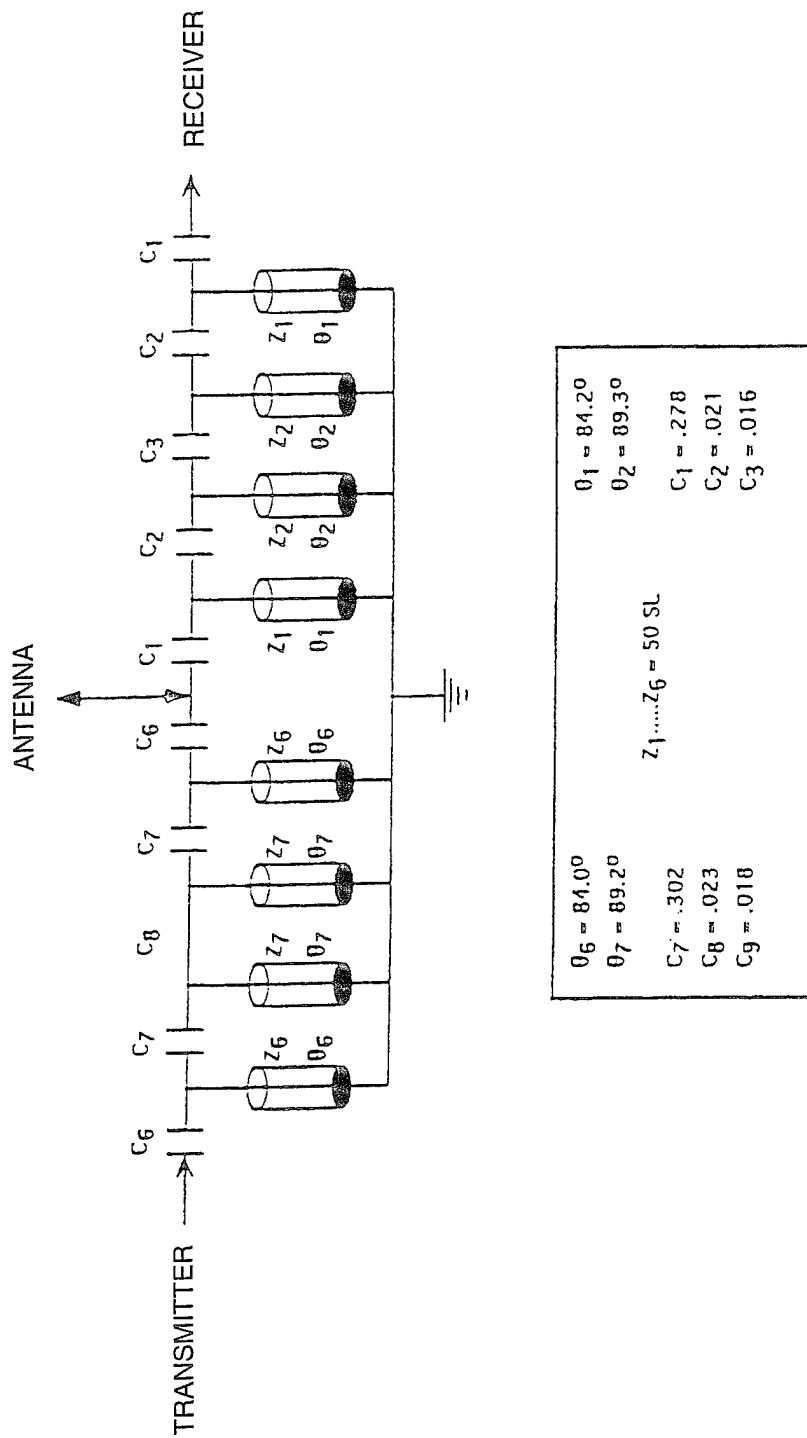

Figure 8. IFF multiplexer schematic.

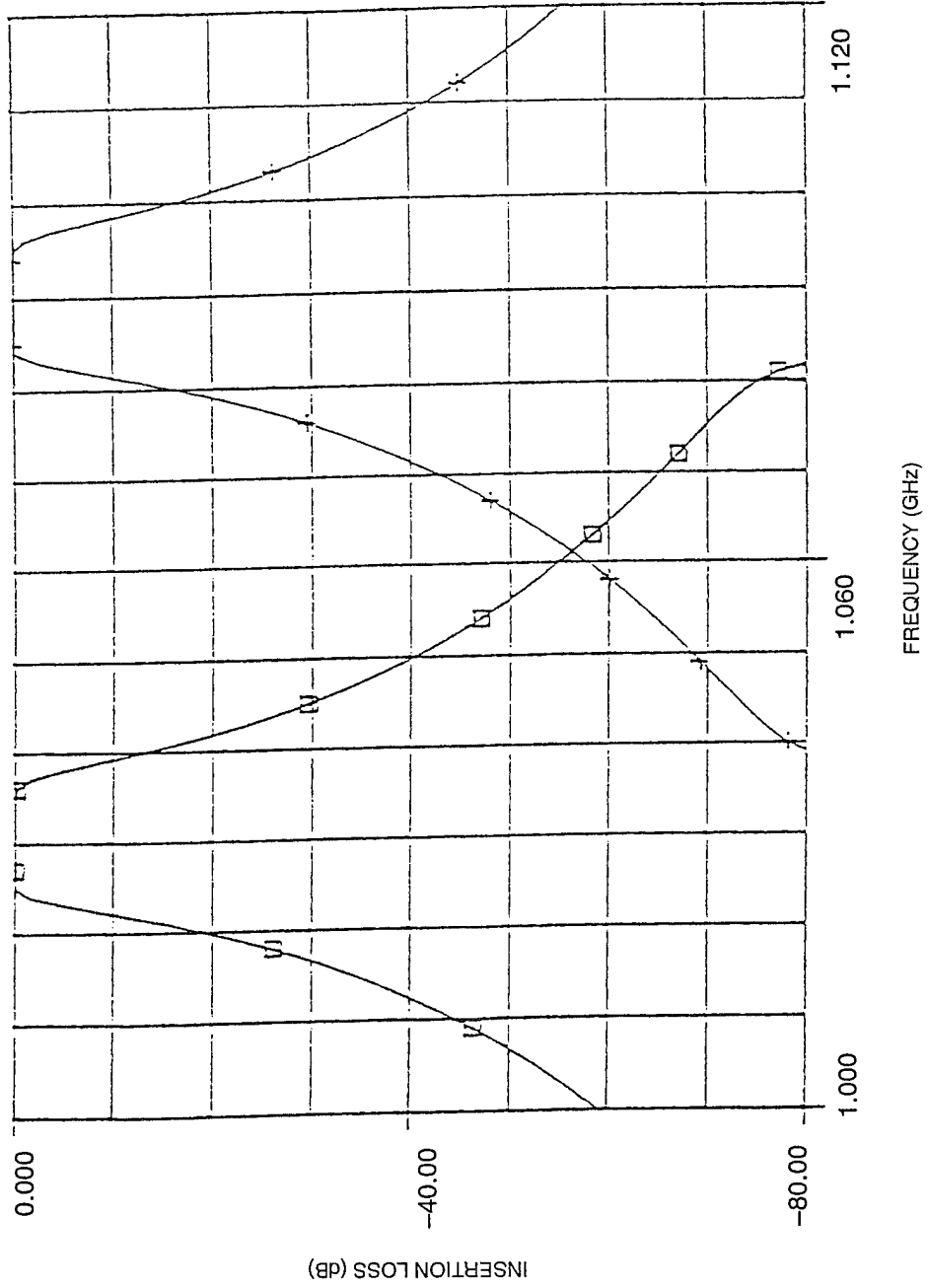

Figure 9. IFF multiplexer performance.

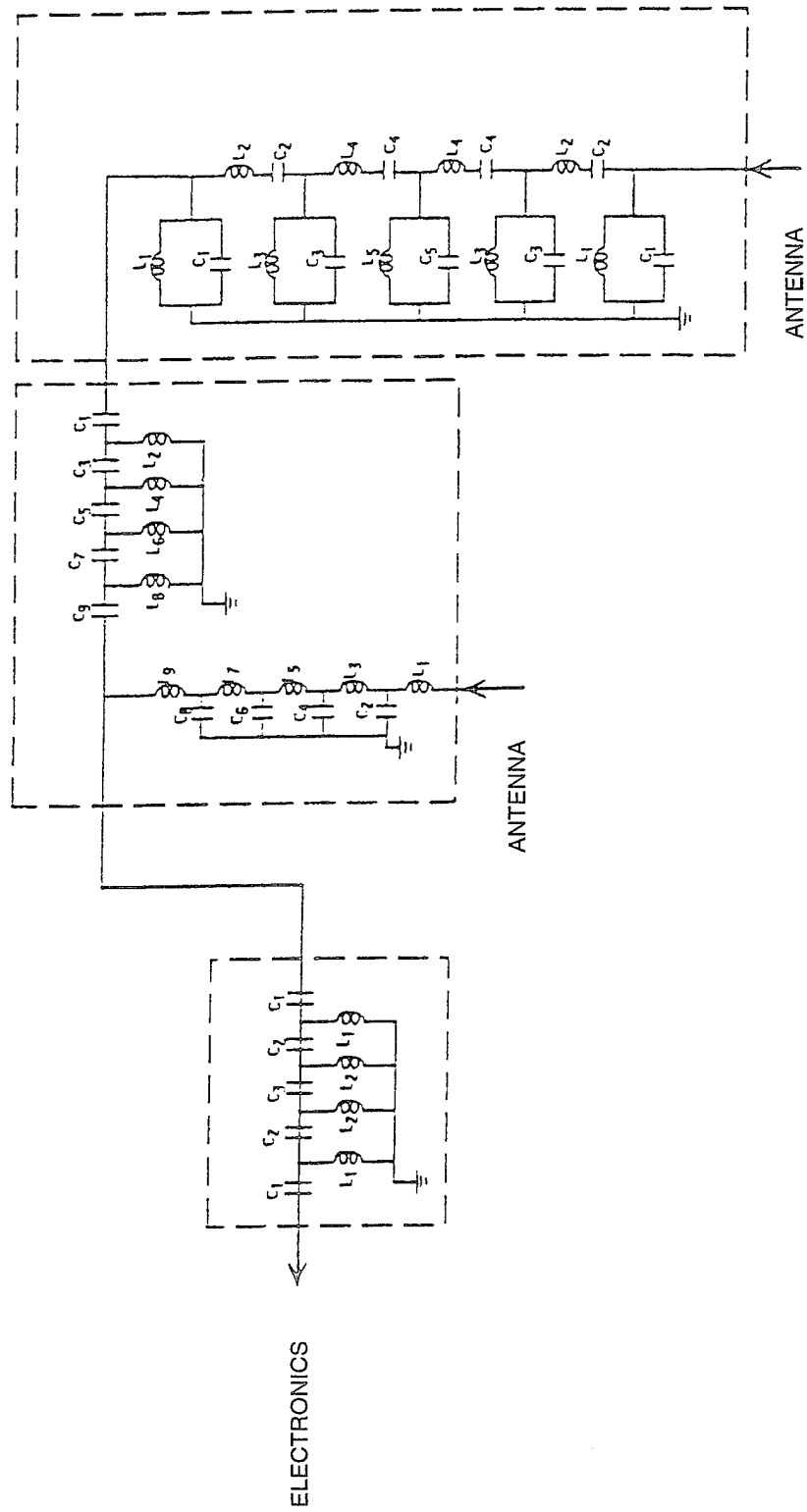

Figure 10. Combat DF multiplexer circuit diagram.

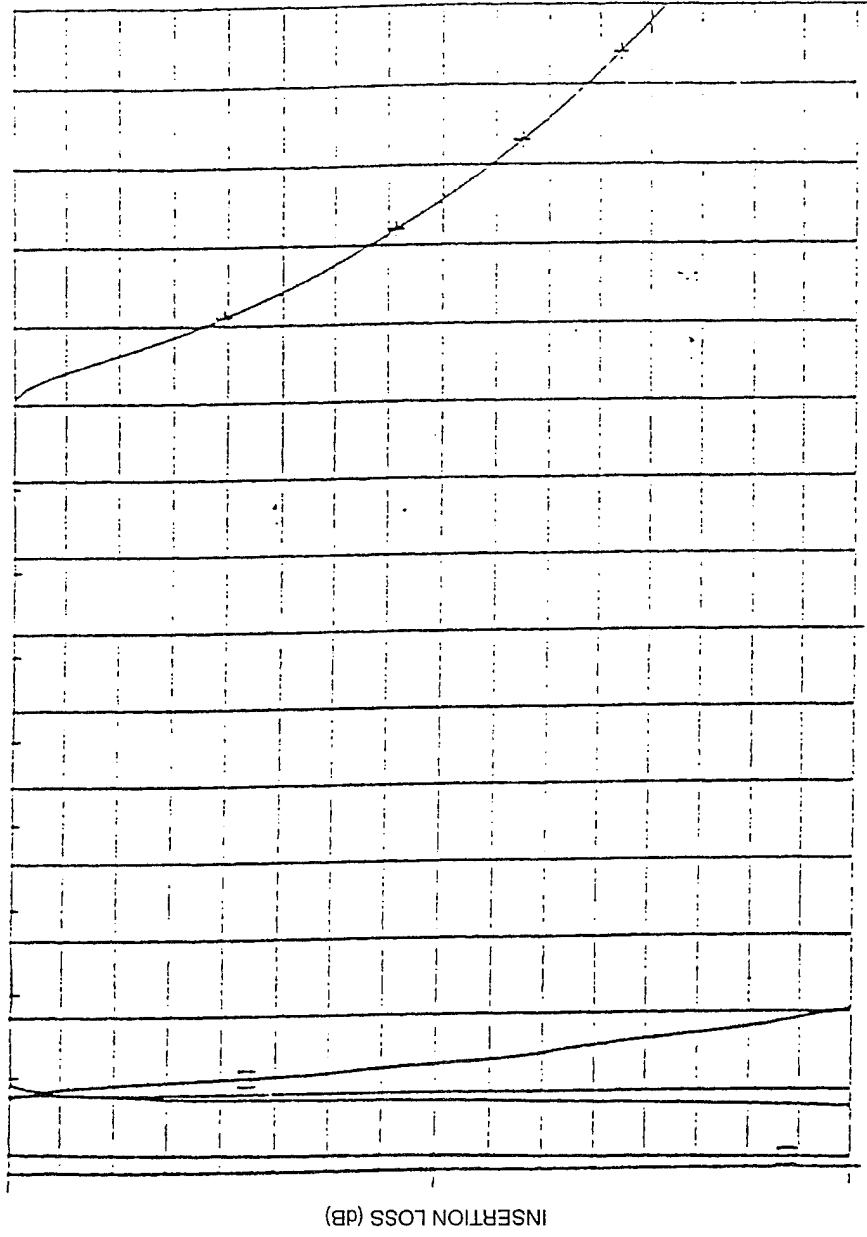

Figure 11. Combat DF multiplexer performance trend.

4. RECOMMENDATIONS AND CONCLUSIONS

There are many possible filter/multiplexer configurations that can be used to satisfy the requirements. Depending on allowable ripple and crossover frequencies, filters having different numbers of reactive elements might be preferable. Three multiplexers were designed. The multiplexers are used to separate VHF from UHF Combat DF, UHF communications from JTIDS, and the IFF transmission from reception. The designs still need to be standardized to commercially available component values. Prototypes need to be fabricated and tested.

Although the frequencies of these filters are relatively low for microwaves, line lengths of connections must be kept minimal to minimize effects from parasitic elements. This is particularly true for wire connections from capacitors to adjacent capacitors. In the case of the IFF multiplexer, it would be necessary to ensure that parasitic inductors will play a minimal role in determining the response of the multiplexer. Standard values for lumped elements must be specified before construction of the actual filter. The issues regarding power rating, size, and weight must also be addressed before the design is finalized.

5. REFERENCES

1. Matthaei, G. L., L. Young, and E. M. T. Jones. 1964. *Microwave Filters, Impedance Matching Networks, and Coupling Structures*, McGraw-Hill, New York, NY.
2. Sagawa, M., M. Makimoto, and S. Yamashita. 1985. "A Design Method of Band-pass Filters Using Dielectric-Filled Coaxial Resonators," *IEEE Transactions, Microwave Theory and Techniques* (Feb), pp. 152-157.

APPENDIX A

As discussed earlier, low-pass ladder networks consist of series inductors and parallel capacitors. Ladder circuits can be designed with series latch-checking (LC) and parallel LC resonant circuits. Consider figure A-1, which shows such a transformation.

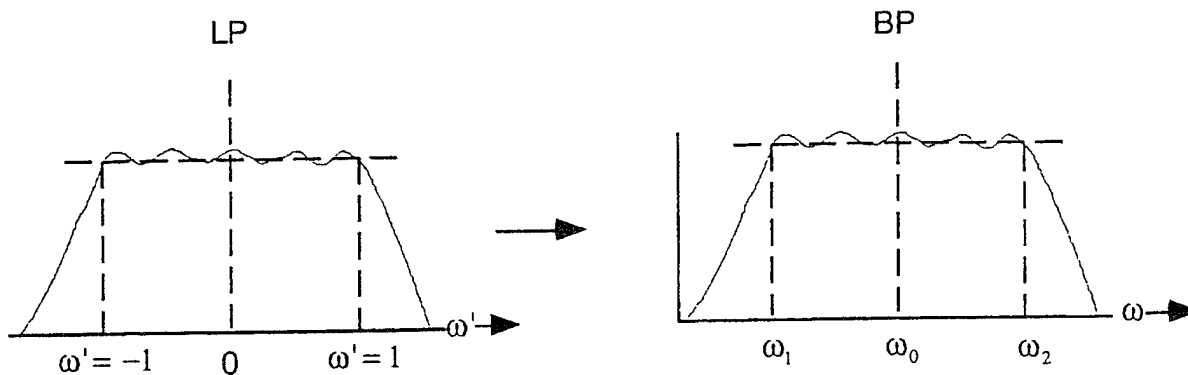

Figure A-1. Transformation from low-pass to band-pass.

Frequencies transform such that:

$$\omega' = \frac{\omega - \frac{\omega_1 \omega_2}{\omega}}{\omega_2 - \omega_1} \quad \Rightarrow \quad \begin{aligned} \omega &= \omega_2 & \text{when } \omega' &= 1 \\ \omega &= \omega_1 & \text{when } \omega' &= -1 \\ \omega &= \sqrt{\omega_1 \omega_2} \equiv \omega_0 & \text{when } \omega' &= 0 \end{aligned} \quad (\text{A-1})$$

$$\text{Let } \Delta\omega = \omega_2 - \omega_1, \quad \text{then } \omega' = \frac{\omega^2 - \omega_1 \omega_2}{\omega(\omega_2 - \omega_1)} \quad \text{or} \quad \omega' = \frac{\omega^2 - \omega_0^2}{\omega \Delta\omega} \quad (\text{A-2})$$

We select one of the dual circuits shown in figure A-2, and scale it to match impedance R_0 .

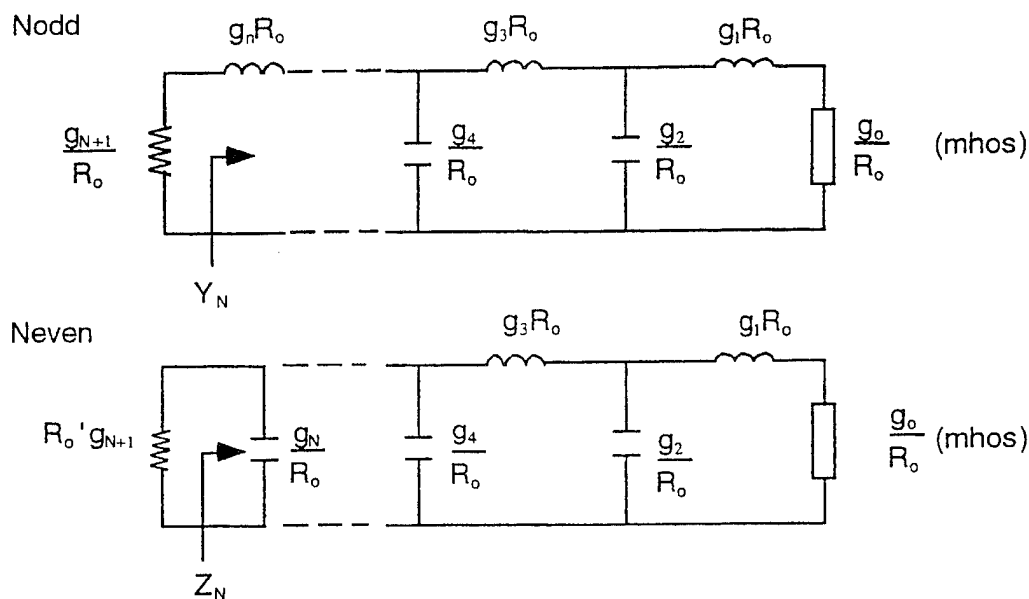

Figure A-2. Dual circuits for band-pass transformation.

To yield the following equations,

$$(Y_N, Z_N) = \frac{1}{j\omega g'_N + \frac{1}{j\omega g'_{N+1} + \dots + \frac{1}{j\omega g'_K + \dots + \frac{1}{g_0}}}} \quad (\text{A-3})$$

for $K=1, \dots, N$ $\begin{cases} g_K = g_K R_0 \text{ (inductor) : } K \text{ odd} \\ g_K = \frac{g_K}{R_0} \text{ (capacitor) : } K \text{ even} \end{cases}$

As a result, the LC equivalents are:

K odd: $= j \left(\frac{\omega^2 - \omega_0^2}{\omega} \right) L_K = j \left(\frac{\omega^2 - \omega_0^2}{\omega \Delta \omega} \right) L_K \Delta \omega = j \left(\frac{\omega^2 - \omega_0^2}{\omega \Delta \omega} \right) L_K \omega_0 W$

K odd: $j\omega [g'_K] \Rightarrow j \left(\frac{\omega^2 - \omega_0^2}{\omega \Delta \omega} \right) L_K \omega_0 W$

$$g'_K = g_K R_0 = L_K \omega_0 W \Rightarrow L_K = \frac{g_K R_0}{\omega_0 W} : C_K = \frac{1}{\omega_0^2 L_K}$$

K even: $jY = j \left(\omega C_K - \frac{1}{\omega L_K} \right) = jC_K \left(\omega - \frac{1}{\omega C_K L_K} \right) = jC_K \left(\omega - \frac{\omega_0^2}{\omega} \right)$
 $= jC_K \left(\frac{\omega^2 - \omega_0^2}{\omega} \right) = j \left(\frac{\omega^2 - \omega_0^2}{\omega \Delta \omega} \right) C_K \Delta \omega = j \left(\frac{\omega^2 - \omega_0^2}{\omega} \right) C_K \omega_0 W$

K even: $j\omega g'_K \rightarrow j \left(\frac{\omega^2 - \omega_0^2}{\omega \Delta \omega} \right) [C_K \omega_0 W]$

$$g'_K = \frac{g_K}{R_0} = C_K \omega_0 W \Rightarrow C_K = \frac{g_K}{\omega_0 W R_0} : L_K = \frac{1}{\omega_0^2 C_K}$$

APPENDIX B

Appendix B shows the necessary steps to go from series/parallel LC band-pass filters to capacitive coupled quarter-wave shorted lines. Referring to steps 1-5 of figure B-1:

1. This step shows a series/parallel LC circuit designed from a low-pass filter prototype. All LC circuits resonate at ω_0 .
2. Admittance inverters J_1 to J_{n+1} allow the series resonant circuits to be replaced by parallel resonant circuits. Two inverters surrounding a parallel LC circuit appear as a series LC circuit but change the impedance level as seen by the rest of the circuit. The inverters J_1 and J_{n+1} act as transformers that change these levels to the desired levels.

The resonator slope parameters are $b_1 \dots b_n$. The slope parameters are defined by the following equation:

$$b_K = \frac{\omega_0}{2} \left(\frac{\partial B_K}{\partial \omega} \right)_{\omega = \omega_0} \quad (\text{B-1})$$

Note that the slope parameters for a simple LC parallel resonant circuit would be $b_K = \omega_0 C_K$. Quarter-wave shorted stubs that are used as resonators have slope parameters of $y_{0_k} \cdot \frac{\pi}{4}$. These act very similar to parallel LC resonant circuits since in both cases the admittance is zero at resonance and the change of admittance with frequency is the same.

The values of J_K and the end values J_1 and J_{n+1} are based on the fractional bandwidth W , the resonator slope parameters, the low-pass prototype parameters, and the load admittances, as shown in figure B-1.

3. The capacitive π network is used with the ends throughout to simulate the inverters found in step 2. The series capacitances C_S are shunted on both sides by negative capacitances of the same value. The end inverter consists of a positive series capacitance and an unequal negative parallel capacitance.
4. The sum of negative capacitances are shown across each resonator. Note that the negative capacitances act like a positive inductance.
5. The admittance of a short-circuited coaxial line at $1/4$ wavelength is zero. At frequencies slightly below this resonance the shorted stub acts like an inductance. Therefore, the stubs must be shorter than $1/4$ wavelength at the center frequency. The coaxial line's characteristic admittance $Y_0 = \frac{1}{Z_0}$ is determined by its capacitance per unit length. Since the required capacitance will be somewhat less than the original, a new value of Y_0 may be required. In practice, for narrow bandwidths this is really unnecessary. Figure B-2, step 5, shows the procedure necessary to use inductive coupling between resonators.

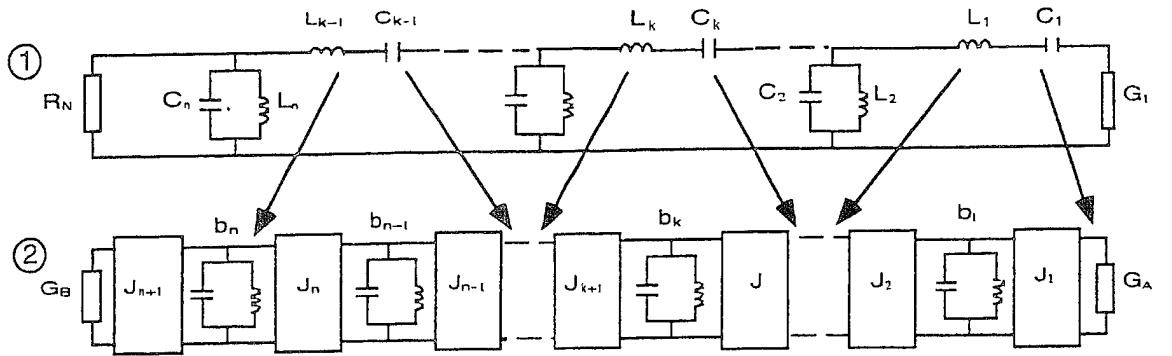

INVERTER VALUES

$$J_{n+1} = \sqrt{\frac{G_B \cdot b_n \cdot W}{g_{n+1}}} \quad J_K = W \sqrt{\frac{b_K - i b_K}{g_K - i g_K}} \quad J_1 = \sqrt{\frac{G_A \cdot b_1 \cdot W}{g_1}} \quad b_K = \text{slope parameter for each resonator}$$

$$\text{for } K = 2 \text{ to } N \quad b_K = \frac{\omega_0}{2} \left(\frac{\partial B_K}{\partial \omega} \right)_{\omega=\omega_0} \quad b_K = y_{\alpha K} \cdot \frac{\pi}{4} \text{ for } \frac{\lambda_0}{4} \text{ shorted stubs}$$

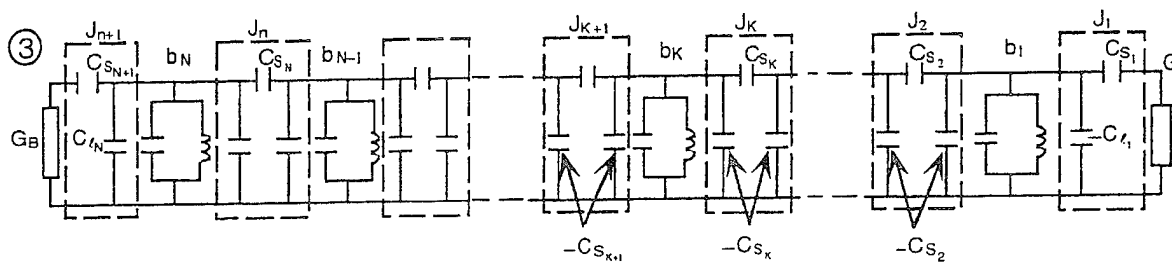

CAPACITANCE VALUES FOR INVERTERS

$$C_{S_N} = \frac{1}{\omega_0 \sqrt{\frac{1}{J_{N+1}^2} - \frac{1}{G_B^2}}} \quad C_{S_1} = \frac{1}{\omega_0 \sqrt{\frac{1}{J_1^2} - \frac{1}{G_A^2}}} \quad -C_{I_N} = \frac{J_{N+1}^2}{\omega_0^2 C_{S_{N+1}}} \quad -C_{I_1} = \frac{J_1^2}{\omega_0^2 C_{S_1}} \quad C_{S_K} = \frac{J_K}{\omega_0}$$

$$\text{for } K = 2 \text{ to } N$$

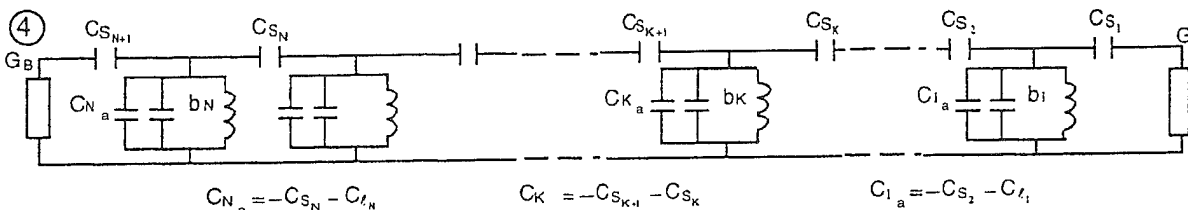

CAPACITIVELY COUPLED COAX RESONATOR FILTER

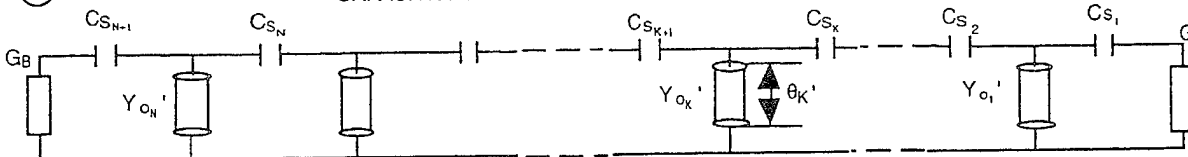

for $K = 1$ to N : solve for θ_K' , such that $\frac{\theta_K'}{\sin \theta_K' \cos \theta_K'} = \left(-\frac{y_{\alpha K}}{\omega_0 C_{K_a}} \frac{\pi}{2} - 1 \right)$ then $Y_{\alpha K}' = -\omega_0 C_{K_a} \cdot \tan \theta_K'$

Figure B-1. Transformation from series/parallel LC band-pass to capacitively coupled quarter-wave shorted lines.

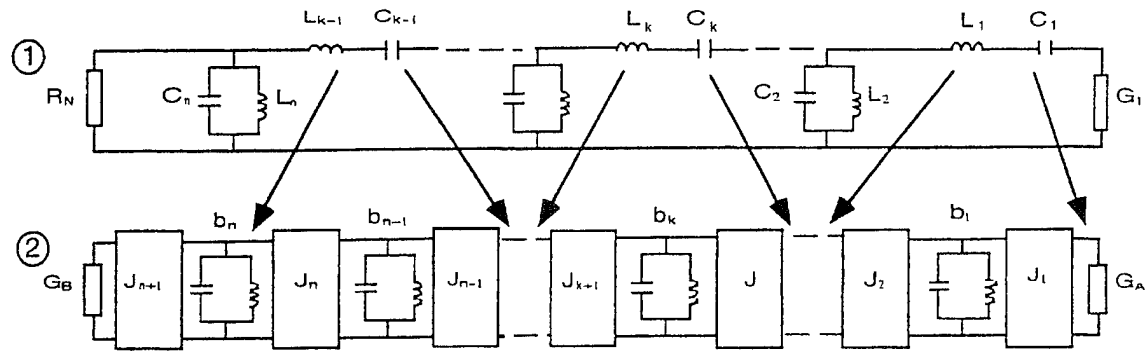

INVERTER VALUES

$$J_{n+1} = \sqrt{\frac{G_B \cdot b_n \cdot W}{g_{n+1}}} \quad J_k = W \sqrt{\frac{b_k \cdot i_{b_k}}{g_{k-1} g_k}} \quad J_1 = \sqrt{\frac{G_A \cdot b_1 \cdot W}{g_1}} \quad b_k = \text{slope parameter for each resonator}$$

$$\text{for } K = 2 \text{ to } N \quad b_k = \frac{\omega_0}{2} \left(\frac{\partial B_k}{\partial \omega} \right)_{\omega=\omega_0} \quad b_k = y_{0k} \cdot \frac{\pi}{4} \text{ for } \frac{\lambda_0}{4} \text{ shorted stubs}$$

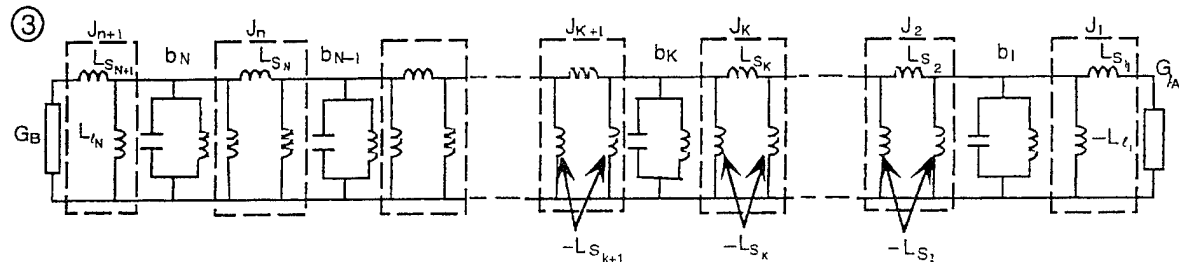

INDUCTANCE VALUES FOR INVERTERS

$$L_{S_N} = \frac{1}{\omega_0 \sqrt{\frac{1}{J_{N+1}^2} - \frac{1}{G_B^2}}} \quad L_{S_1} = \frac{1}{\omega_0 \sqrt{\frac{1}{J_1^2} - \frac{1}{G_A^2}}} \quad -L_{S_{k+1}} = \frac{J_{N+1}^2}{\omega_0^2 L_{S_{N+1}}} \quad -L_{S_k} = \frac{J_1^2}{\omega_0^2 L_{S_1}} \quad L_{S_k} = \frac{J_k}{\omega_0}$$

$$\text{for } K = 2 \text{ to } N$$

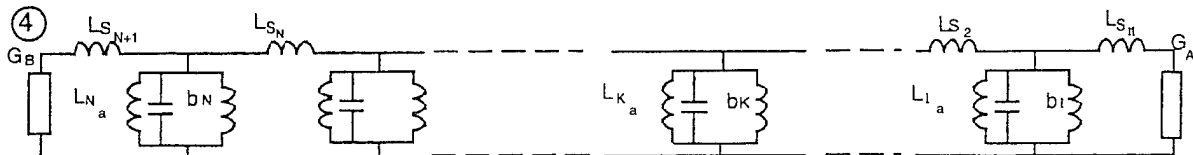

$$L_{N_a} = \frac{-1}{\frac{1}{L_{S_N}} + \frac{1}{L_{S_{N+1}}}} \quad L_{K_a} = \frac{-1}{\frac{1}{L_{S_{k+1}}} + \frac{1}{L_{S_k}}} \quad L_{1_a} = \frac{-1}{\frac{1}{L_{S_1}} + \frac{1}{L_{S_2}}}$$

INDUCTIVELY COUPLED COAX RESONATOR FILTER

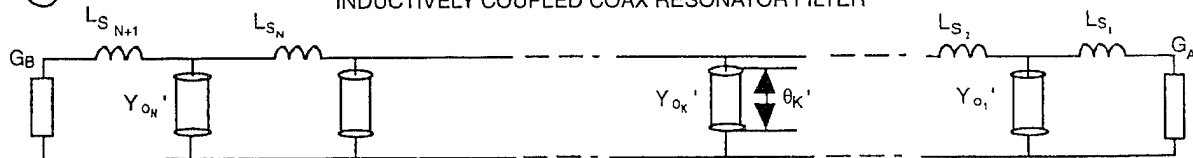

$$\text{for } K = 1 \text{ to } N: \text{ solve for } \theta_K', \text{ such that } \frac{\theta_K'}{\sin \theta_K' \cos \theta_K'} = \left(\omega_0 L_{K_a} y_0 \cdot \frac{\pi}{2} + 1 \right) \text{ then } Y_{0k}' = \frac{1}{\omega_0 L_{K_a}} \cdot \tan \theta_K'$$

Figure B-2. Procedure for realizing inductive coupling between resonators.

REPORT DOCUMENTATION PAGE

Form Approved
OMB No. 0704-0188

Public reporting burden for this collection of information is estimated to average 1 hour per response, including the time for reviewing instructions, searching existing data sources, gathering and maintaining the data needed, and completing and reviewing the collection of information. Send comments regarding this burden estimate or any other aspect of this collection of information, including suggestions for reducing this burden, to Washington Headquarters Services, Directorate for Information Operations and Reports, 1215 Jefferson Davis Highway, Suite 1204, Arlington, VA 22202-4302, and to the Office of Management and Budget, Paperwork Reduction Project (0704-0188), Washington, DC 20503.

1. AGENCY USE ONLY (Leave blank)		2. REPORT DATE <p style="text-align: center;">September 1995</p>	3. REPORT TYPE AND DATES COVERED <p style="text-align: center;">Final: August 1995</p>	
4. TITLE AND SUBTITLE <p style="text-align: center;">MULTIPLEXERS FOR MULTIFUNCTION ELECTROMAGNETIC RADIATING SYSTEMS (MERS)</p>		5. FUNDING NUMBERS <p style="text-align: center;">PE: 0602232N AN: DN305458</p>		
6. AUTHOR(S) <p style="text-align: center;">W. Henry, T. Q. Ho, M. Mills, D. Rubin</p>		8. PERFORMING ORGANIZATION REPORT NUMBER <p style="text-align: center;">TD 2852</p>		
7. PERFORMING ORGANIZATION NAME(S) AND ADDRESS(ES) <p style="text-align: center;">Naval Command, Control and Ocean Surveillance Center (NCCOSC) RDT&E Division San Diego, California 92152-5001</p>		10. SPONSORING/MONITORING AGENCY REPORT NUMBER		
9. SPONSORING/MONITORING AGENCY NAME(S) AND ADDRESS(ES) <p style="text-align: center;">Office of Naval Research 800 North Quincy Street Arlington, VA 22217</p>		10. SPONSORING/MONITORING AGENCY REPORT NUMBER		
11. SUPPLEMENTARY NOTES				
12a. DISTRIBUTION/AVAILABILITY STATEMENT <p style="text-align: center;">Approved for public release; distribution is unlimited.</p>			12b. DISTRIBUTION CODE	
13. ABSTRACT (Maximum 200 words) <p>The Multiplexers for Multifunction Electromagnetic Radiating Systems (MERS) objective was to merge four different radio frequency (RF) sensor systems into a single-antenna structure. Currently, the four candidates are Combat Direction Finding (CDF), Identification Friend or Foe (IFF), Joint Tactical Information Distribution System (JTIDS), and UHF communications. This report demonstrates that the merged antenna system is a low-cost system that decreases topside space and weight requirements while it also improves the multiple system performance. The ultimate goal is to provide a family of MERS antennas that meet each ship class antenna requirement in a combined and optimized structure. This report discusses the requirements, system concept for MERS, theoretical aspects, and the numerical results behind the multiplexer designs. Recommendations for future work are also included.</p>				
14. SUBJECT TERMS Merged antenna system Multiplexers Low-pass filter High-pass filter Band-pass filter			15. NUMBER OF PAGES <p style="text-align: center;">28</p>	
17. SECURITY CLASSIFICATION OF REPORT <p style="text-align: center;">UNCLASSIFIED</p>			16. PRICE CODE	
18. SECURITY CLASSIFICATION OF THIS PAGE <p style="text-align: center;">UNCLASSIFIED</p>		19. SECURITY CLASSIFICATION OF ABSTRACT <p style="text-align: center;">UNCLASSIFIED</p>		20. LIMITATION OF ABSTRACT <p style="text-align: center;">SAME AS REPORT</p>

UNCLASSIFIED

21a. NAME OF RESPONSIBLE INDIVIDUAL T. Q. Ho	21b. TELEPHONE (include Area Code) (619) 553-3783	21c. OFFICE SYMBOL Code 822

INITIAL DISTRIBUTION

Code 0012	Patent Counsel	(1)
Code 0271	Archive/Stock	(6)
Code 0274	Library	(2)
Code 80	K. D. Regan	(1)
Code 85	G. Beagler	(1)
Code 8505	J. W. Rockway	(2)
Code 851	L. Russell	(1)
Code 851	W. Henry	(5)
Code 851	T. Q. Ho	(10)
Code 851	S. T. Li	(1)
Code 851	G. Kosinovsky	(1)

Defense Technical Information Center
Fort Belvoir, VA 22060-6218 (4)

NCCOSC WASHINGTON LIAISON OFFICE
Washington, DC 20363-5100

Center for Naval Analyses
Alexandria, VA 22244-5114

Navy Acquisition, Research & Development
Information Center (NARDIC)
Arlington, VA 22244-5114

GIDEP Operations Center
Corona, CA 91718-8000

Office of Naval Research
Arlington, VA 22217-5000

Naval Surface Warfare Center
Carderock Division
Bethesda, MD 20084-5000 (6)

Naval Sea Systems Command
Arlington, VA 22242-5160