

NATIONAL AIR INTELLIGENCE CENTER

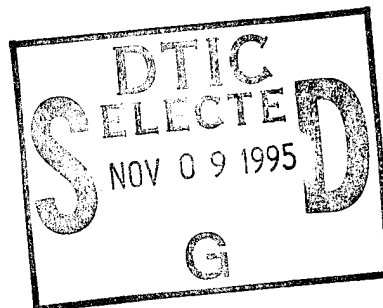

ANALYTICAL STUDY OF THE STATUS OF ANTISATELLITE WEAPON DEVELOPMENT



DTIC QUALITY INSPECTED 5

Approved for public release:
distribution unlimited

19951108 024

NAIC- ID(RS)T-0263-95

HUMAN TRANSLATION

NAIC-ID(RS)T-0263-95 27 September 1995

MICROFICHE NR: 95C 000613

ANALYTICAL STUDY OF THE STATUS OF ANTISATELLITE WEAPON DEVELOPMENT

English pages: 41

Source: Fan Wei Xing Wu Qi Yan Zhi Zhuang Kuand de Fen Xi
Yan Jiu; pp. 38-51

Country of origin: China

Translated by: SCITRAN

F33657-84-D-0165

Requester: Richard A. Peden, Jr.

Approved for public release: distribution unlimited.

THIS TRANSLATION IS A RENDITION OF THE ORIGINAL FOREIGN TEXT WITHOUT ANY ANALYTICAL OR EDITORIAL COMMENT STATEMENTS OR THEORIES ADVOCATED OR IMPLIED ARE THOSE OF THE SOURCE AND DO NOT NECESSARILY REFLECT THE POSITION OR OPINION OF THE NATIONAL AIR INTELLIGENCE CENTER.

PREPARED BY:

TRANSLATION SERVICES
NATIONAL AIR INTELLIGENCE CENTER
WPAFB, OHIO

NAIC- ID(RS)T-0263-95

Date 27 September 1995

GRAPHICS DISCLAIMER

All figures, graphics, tables, equations, etc. merged into this translation were extracted from the best quality copy available.

Accession For	
NTIS CRA&I	<input checked="" type="checkbox"/>
DTIC TAB	<input type="checkbox"/>
Unannounced	<input type="checkbox"/>
Justification	
By	
Distribution/	
Availability Codes	
Dist	Avail and/or Special
A-1	

I. INTRODUCTION

As far as the birth of artificial satellites and the development of space flight technology are concerned, they have propelled social progress as well as stimulating international cooperation and the development of global resources. However, at the same time as this, due to unceasing expansion of military applications, the arms race has also been introduced into outer space, causing space to change into a battleground for a mutual struggle between the U.S. and the Soviets (referring to the former Soviet Union, here and following) for "space supremacy".

The development of new fields of high science and technology always achieves its first applications in the military. The two countries possessing the largest numbers of satellites in the world--the U.S. and the Soviets--had, as their original intention in developing artificial satellites, the serving of military objectives. According to statistics, U.S. military satellites account for 73% of that countries total number of satellites. The Soviets' account for 70%. Military satellites are distributed from as close as 150km low earth orbits to as far as 36000km geosynchronous orbits. They are capable of carrying out observations in every direction against the earth. There is no way for any other means to compare with this. These military satellites combine reconnaissance, missile warning, communications, navigation, oceanic monitoring, arms control treaty verification, geodesy, weather forecasting, and other

* Numbers in margins indicate foreign pagination.
Commas in numbers indicate decimals.

such functions in one. They play the role of eyes, ears, and nerve center of national military sources. For the highest national military command and policy making agencies, they are capable of supplying in real time large amounts of strategic and tactical information. On the basis of reports, the U.S. and the Soviets have acquired 70% of their information on the other side from military space satellites.

In many instances of limited war in the recent past--for example, the mideast wars, the British Falklands war, and the U.S.-Libya war--in all cases, military satellites acted in support. In particular, during the Gulf crisis and the Gulf War, from August 1990 to February 1991, military satellites for the first time underwent full testing in a real war. The U.S., the U.K., and France made use of 70 military satellites of 7 types, composing together, with space and ground systems, a main communications, reconnaissance, warning, navigation, and weather forecasting network, turning into a multiplier of the military power of the units of many nations so as to play an active role in the Gulf War victory. Because of this, it was demonstrated even more clearly that military satellite systems have become a key component part of modern military operational command systems and strategic weapons systems. At the present time, the degree of U.S. and Soviet dependence on military satellites becomes greater and greater, almost to the point where they are not /39 capable of implementing military actions apart from satellites.

As far as broad applications of satellites to the military are concerned, they constitute a threat to the military forces of opponents, necessarily bringing with them space defense questions. In order to vie for control of a dominant position in outer space, the U.S. and the Soviets, not long after the introduction of artificial satellites, then began the development of antisatellite weapons. In the

1960's, the Soviets began to carry out research and testing on coorbital type antisatellite weapons. In the 1970's, they then achieved an operational capability to attack low earth orbit satellites. They were the only nation in the world possessing an actual antisatellite combat capability. The U.S. began developing antisatellite weapons at the end of the 1950's. Although there was constant domestic debate on the development of antisatellite weapons right along, with regard to the development and testing of this type of weapon, however, it still has not stopped. From the SAINT at the end of the 1950's, and such projects as the Nike-Zeus, to the F- 15 antisatellite project of the 1970's, as well as the kinetic energy and directed energy antisatellite projects drawn up accompanying the "Star Wars" project of the 1980's, the weapons designs become even more mature, and technology levels as well as weapons precisions increase with every passing day. At the same time, it also makes the U.S.-Soviet arms race in space even more intense.

This article is limited in scope and omits these matters.

II. STATUS OF SOVIET ANTISATELLITE WEAPON DEVELOPMENT

In 1964, the Soviet Union set up a space defense command. The aim lay in studying national space weapon development. Countering satellites was listed as a primary mission of space defense. Coorbital types of antisatellite interception devices are the key model associated with the development. In the period 1968 ~ 1982, 20 antisatellite tests were carried out, reaching actual combat levels. Besides this, the Soviet Union also carried out research and

explorations in such technological realms as directed energy to counter satellites, opposing missiles to counter satellites, space shuttles and manned space stations to counter satellites, airborne weapons to counter satellites, as well as space mines and radio frequency weapons to counter satellites, and so on.

Here, what needs to be pointed out is that a complete antisatellite system is normally composed of three parts: a space monitoring subsystem, a command and control subsystem, and an antisatellite weapon subsystem. The space monitoring subsystem is used to detect and track satellites, analyzing and processing obtained data and precisely specifying satellite orbit and characteristic parameters--for example, mass, configuration, functions, as well as other optical characteristics. Command and control subsystems, by contrast, are those forming command and control orders on the basis of the space monitoring subsystem data. In the U.S. and the Soviet Union, both sides have global space monitoring systems and C3I systems. These are established on the basis of the requirements of missile warning systems and the requirements of national space flight projects. However, antisatellite weapon subsystems are only borrowing the use of their functions or a part of them, so to speak. Therefore, antisatellite system development is mainly only the development of antisatellite interception devices. This article simply carries out an analysis and introduction of antisatellite weapons and omits the subjects of space monitoring subsystems and command and control subsystems.

1. Coorbital Type Antisatellite Interception Devices

Coorbital antisatellite interception devices are one type of interception device based on using satellites against satellites. They are also called "interceptor

satellites" or "killer satellites".

The tactical technological capabilities are as follows:

- Antisatellite device length is 4.5 ~ 6 meters. Mass is 2500 kilograms. They are equipped with one main engine and 5 orbital maneuver engines. The propellant used to change orbits reaches over 500 kilograms. In conjunction with this, they are equipped with attitude control engines. The rough structure is as shown in Fig.1.

- Guidance methods opt for the use of radar or infrared homing guidance. Guidance accuracies are within 1km range of target satellites.

- As far as delivery means are concerned, option is made for the use of SS-9 intercontinental ballistic missiles modified as F-1-m rockets. The launch altitude is 140 ~ 1638 km. Orbital angles of inclination are 50° ~ 71°. Useful load capability is 4785 tons.

- Combat reaction time is 90 minutes.

- Orbital maneuver capability is 5° ~ 10°.

- Relative velocities approaching targets are 40 ~ 400 m/sec.

- The length of combat launch area is approximately 1500km. The width is approximately 1000km.

/40

- Time for interception of target satellites is approximately 1 hour (interception in first ring orbits) to 3.8 hours (interception in second ring orbits).

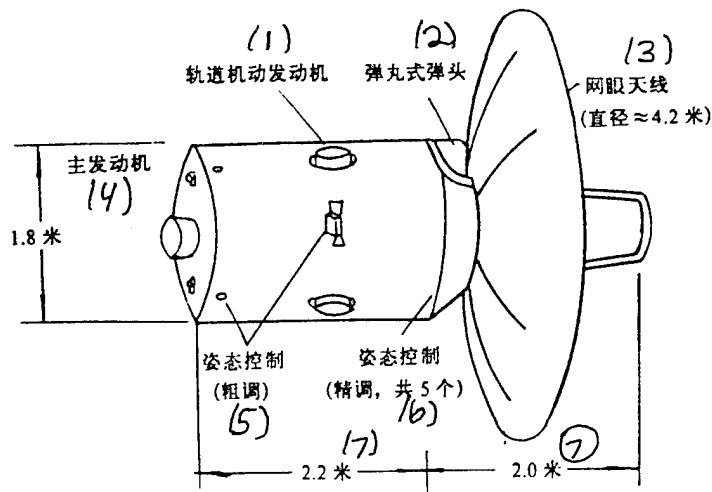

Fig.1 Schematic of Soviet Antisatellite Interception Device

Key: (1) Orbital Maneuver Engine (2) Bullet Type Warheads (3) Mesh Antenna (Diameter \approx 4.2 meters) (4) Main Engine (5) Attitude Control (Rough Adjustment) (6) Attitude Control (Fine Adjustment. 5 Altogether.) (7) Meter

■ Combat component mass is 363 kilograms. Option is made for the use of proximity fuse high explosives. They explode when they approach to within a few dozen meters of targets. Satellites are destroyed through the production of large amounts of fragments. Shrapnel pieces present a rhombic shape. Mass is 0.5 ~ 2 grams. Fragment speeds are 305 ~ 610 m/sec.

■ Combat altitude is 150 ~ 2000km. It is capable of attacking military satellites and other spacecraft in low earth orbit.

■ There are two principal types of combat. One type is coplanar orbital attack, that is, intercepting satellites entering into an orbit close to the target orbit plane and altitude. Through maneuvers of themselves--after making some flights around the earth--the target is gradually approached. After targets are approached to a certain distance and relative speeds reach a few meters a second to a few hundred meters a second, combat sections detonate, and the fragments destroy the satellite. The second type is high speed ascent attack, that is, taking interception devices and launching them into a orbit in the same plane as the orbit of the target satellite at a lower altitude. Following that, through maneuvering in quick ascent to approach the satellite, it is possible, in the second orbit loop, to destroy the target satellite. Obviously, the combat effectiveness of this type of interception method is higher than the first type. Coplanar type interception device flight orbit schematics are as shown in Fig.2(a).

In October 1968, the Soviet Union began to carry out antisatellite flight tests. In 1978, it was announced that they had achieved actual combat levels. In June 1982, the last tests ended. Altogether, 20 were carried out. Antisatellite tests were carried out divided into three stages. After each stage there was a period of temporary halt. The detailed status of tests was as seen in Table 1.

In August 1983, the Soviet Union unilaterally announced that they would not make use of antisatellite weapons first, and they requested a resumption of talks with the U.S. After that, they did not again carry out interception device tests.

From the results of Table 1 tests, it is possible to see that the targets attacked in the 20 antisatellite tests were all space satellites (target satellites). Although all

the tests which opted for the use of infrared homing guidance were failures, among 14 tests which opted for the use of radar homing guidance, however, 9 achieved success. The success rate reached 60%. The explanation is that antisatellite interception devices were already relatively mature technologically, and it was possible to put them to combat use. The final 18 June 1982 antisatellite test was capable of demonstrating this point. This exercise was carried out strictly in accordance with procedures for the outbreak of a nuclear war. The scale was unprecedented. In the test, use was made of command, control, and communications systems selected for utilization when the Soviet Union carries out nuclear strikes against Europe and the U.S. First of all, antisatellite weapons are launched, simulating destruction of U.S. reconnaissance satellites. Following that, two SS-11 intercontinental missiles, 1 SS-20 intermediate ballistic missile, 1 underground missile, and 2 antiballistic missiles were launched. The exercise continued for 7 hours. As far as this test is concerned, although the interceptor satellite fuse developed a malfunction and was not successful, it still reflected, however, that the Soviet Union had already put antisatellite weapons into the structures for a future nuclear war, and they were a part of the realm of military strategy which could not be done without. At the same time, the explanation for this is also that the Soviet Union already possessed the capability to provide antisatellite weapons systems to use in real combat. On the basis of reports, the weapons systems in question were deployed at Qiulatanmu (phonetic) launch site and maintained in a constant standby status.

/41

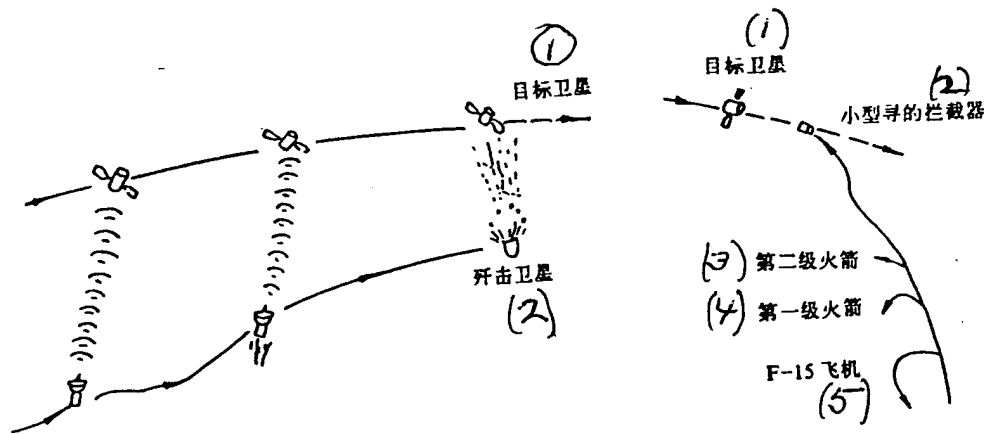

Fig.2 Antisatellite Interception Orbit Schematic (a) Orbital Type (1) Target Satellite (2) Fighter Satellite (b) Interception Type

Key: (1) Target Satellite (2) Small Scale Homing Interception Device (3) Second Stage Rocket (4) First Stage Rocket (5) Aircraft

Although coorbital type antisatellite interception devices possess a certain combat capability, severe inadequacies still exist, however. For example, interception devices are only capable of attacking satellites flying over launch sites. This type of opportunity comes only twice in a day. As a result, target interception opportunities are limited. The time required from launch to interception is relatively long. This will give the satellite being attacked time to adopt counter

measures. Systems are huge. Launch positions are fixed. Flexibility is bad. Launches are only possible from a small number of launch sites. Moreover, it is also quite difficult to continue to rapidly carry out launches from one launch site.

① 次数	② 阶段	③ 试验日期	④ 拦截卫星(宇宙 号序号)	⑤ 靶星(目标卫星)			⑩ 拦截 高度 (公里)	⑪ 制导 方式	⑫ 攻击时 飞行 圈数	从发射 到截击 的时间 (小时)	⑬ 试验 结果	
				⑥ 宇宙号 序号	⑦ 近地点/ 远地点 (公里)	⑧ 运行 周期 (分)						⑨ 轨道 倾角 (度)
1	⑮	1968.10.20	249	248	490 / 551	94.8	62.3	525	⑭ 雷达	2	3.5	失败 ⑳
2	第一 阶段	1968.11.1	252	248	473 / 543	112.2	62.3	535	雷达	2	3.5	成功 ㉑
3		1970.10.23	374	373	472 / 544	94.8	62.9	530	雷达	2	3.8	失败
4		1970.10.30	375	373	466 / 555	112.4	63	535	雷达	2	3.8	成功
5		1971.2.25	397	394	574 / 619	96.5	65.8	585	雷达	2	3.7	成功
6		1971.4.4	404	400	995 / 1016	105.0	65.8	1005	雷达	2	3.67	成功
7		⑯	1971.12.3	462	459	226 / 277	89.4	65.8	230	雷达	2	3.5
8	第二 阶段	1976.2.16	804	803	554 / 618	97.0	65.8	575	雷达	1		失败
9		1976.4.13	814	803	549 / 621	90.6	65.1	590	雷达	1	0.7	成功
10		1976.7.21	843	839	583 / 2097	110	65.9	1630	雷达	2		失败
11		1976.12.27	886	880	560 / 617	96.4	65.9	570	⑭ 红外	2	1.67	失败
12		1977.5.23	910	909	991 / 2112	117	65.9	1710	雷达	1		失败
13		1977.6.17	918	909	991 / 2106		65.9	1575	雷达	1		成功
14		1977.10.26	961	959	153 / 890	96	66	150	雷达	2		成功
15		1977.12.21	970	967	977 / 1013	105	65.8	995	红外			失败
16	⑰	1978.5.19	1009	967	963 / 1004		65.1	985	红外	2		失败
17	第三 阶段	1980.4.18	1174	1171	966 / 1010	98.6	65.8	1000	红外	2		失败
18		1981.2.2	1243	1241	978 / 1012	105	65.8	1005	红外	2.5		失败
19		1981.3.14	1258	1241	975 / 1011	105	65.9	1005	雷达	2.5		成功
20		1987.6.18	1379	1375	977 / 1010	100.4	65.8	1005	红外	2		失败

Table 1 Coorbital Type Antisatellite
Interception Device Test Status

Key: (1) Iteration No. (2) Phase (3) Test Time (4)
Interception Satellite (Cosmos Series No.) (5) Target
Satellite (Object Satellite) (6) Cosmos Series No. (7)
Perigee/Apogee (km) (8) Orbital Period (Minutes) (9)
Orbital Angle of Inclination (Degrees) (10) Interception
Altitude (Kilometers) (11) Guidance Mode (12) Number of
Flight Loop at Time of Attack (13) Period from Launch to
Interception (Hours) (14) Test Result (15) First Phase
(16) Second Phase (17) Third Phase (18) Radar (19)
Infrared (20) Failure (21) Success

2. Directed Energy Antisatellite Weapons

Directed energy weapons include laser weapons and beam weapons. They primarily use thermal effects, shock effects, and radiation effects to kill and damage satellites. They possess such characteristics as fast speeds, high precisions, great killing and damaging power, and strong capabilities to resist electronic interference. They are a type of relatively ideal antisatellite weapon. There are three high energy laser antisatellite weapon deployment modes: ground, air, and space. The Soviet Union has made relatively great progress on development work in the area of laser weapons. However, the development of particle beam antisatellite weapons is relatively laggard compared to it.

The Soviet Union began developing antisatellite laser weapons in the 1960's. The main emphasis was on the development of ground based laser weapon technology. However, at the same time, they also began the development of space based and airborne laser technology. In order, the lasers developed included: electrical discharge lasers, chemical lasers, X ray lasers, free electron lasers, quasi molecular lasers, as well as argon ion lasers, and so on.

Ground based antisatellite lasers began to go into testing in the 1970's. In the middle 1980's, two lasers installed at the Saleishagan (phonetic) test range already possessed antisatellite capabilities. U.S. reconnaissance satellites discovered two huge installations built on top of Nuleike (phonetic) mountain in the Dushang (phonetic) autonomous region close to the Afghanistan border. It is also very possible that they have antisatellite

capabilities.

Space based antisatellite weapons are an important target of Soviet development. According to original project estimates, if technological development was smooth, it would be possible to bring out space based laser antisatellite weapons prototypes in the late 1980's. Beginning deployment would perhaps be possible in the 1990's. At the same time, it was estimated that small deployments of airborne laser antisatellite weapons would also be possible in the early 1990's.

Particle beam weapon development also began in the 1960's. Original preparations were made in the early 1990's to carry out prototype tests on interference technology to destroy electronic equipment carried on satellites. In conjunction with this, early next century, research and design will begin on practical systems to destroy whole satellites.

Besides coorbital type antisatellite interception devices which have already been deployed and directed energy antisatellite weapons which are just now under development, the Soviet Union also has weapons possessing the several types of antisatellite capabilities below.

- The "Rubber Overshoes" antimissile system possesses a capability to intercept U.S. low orbit satellites.

- Space shuttles and space stations are capable of acting as space based antisatellite weapons platforms to support antisatellite operations.

- Radio frequency weapons possess the capability to carry out electronic jamming.

- Airborne antisatellite weapons.
- Space mine antisatellite weapons.
- Kinetic energy antisatellite weapons.

III. THE STATUS OF U.S. ANTISATELLITE WEAPON DEVELOPMENT

1. Early Antisatellite Projects

As far as early stages are concerned, that refers to the years 1957 to 1975. In this period, the main U.S. defense focus was primarily to resolve the problems of antiballistic missiles. As a result, it was primarily based on the establishment of antiballistic missile systems. However, at the same time as this, use was also being made of antimissile systems to carry out exploration of paths for antisatellite technology. A number of antisatellite technology tests were done. Land, sea, and air forces all introduced this type of project. In conjunction with this, they set out their own individual development projects. /43

Early antisatellite projects included: the SAINT project, the Nike-Zeus project, the Thor project, and the Early Spring project.

Besides these few antisatellite projects, the U.S. also carried out antisatellite weapons launch tests in 1959 (Air Force) and 1962 (Navy) from the B-47 bomber and the F-4 fighter respectively. The Minuteman antiballistic missile system also had dual antisatellite capabilities. Besides this, in 1965, the U.S. also set out the "Manned Orbital

Laboratory" project. Development responsibility was taken by the Air Force. The main missions were reconnaissance, monitoring, and destruction of the enemy, including various types of space targets--satellites among them. There were two types of modes for laying weapons. One type was orbit to ground. The other type was orbit to orbit. Later, due to replacement by preparations to use the space shuttle and space station, cancellation was, therefore, announced in 1969.

2. F-15 Antisatellite Project

Due to reasons in the areas of technology, economics, and politics, early nuclear missile antisatellite projects were all canceled. In the middle 1970's, the Soviet Union already possessed the capability to supply antisatellite weapons for actual combat use. This made the U.S. nervous. They began to pay serious attention to antisatellite weapon development. In conjunction with this, they took the focus and turned it toward nonnuclear antisatellite weapons systems. At this time, it was possible to supply several types of selected designs. One type is similar to the Soviet ground based coplanar type antisatellite interception design. The Minuteman intercontinental ballistic missile acted as the delivery vehicle. The mass of the interception device installed on top of the booster stage of the missile was approximately 455 kilograms. Another type was directed energy antisatellite weapons. At this time, the U.S. already began to invest in more advanced weapons such as directed energy weapons, and so on. However, they considered directed energy weapons at this time to still be in the stage of developing experimental principles. Realization posed definite difficulties. Mastery was not complete. Another type was nothing else than a plan to fire

antisatellite missiles from F-15 aircraft. Finally, the third plan was selected.

Selection of the third plan may have been based on the following considerations. Almost all Soviet military satellites moved in low earth orbits. There were a lot of them. Their lives were short. Replacement was frequent. Each year close to a hundred were launched. As a result, the U.S. needed a type of antisatellite weapon that was fast reacting, low cost, numerous, and technologically relatively well mastered, and F-15 aircraft launching antisatellite missiles fit this type of requirement.

The F-15 antisatellite project was the responsibility of the U.S. Air Force. The main contractors were Wote (phonetic) company, the Boeing company, and the McDonald Douglas company. The development process was more or less as follows. 1975 and 1976 were the preliminary research stage. 1977 was the development phase. 1978 was the final design phase. 1980 was the entry into the engineering development phase. In 1981, full scale engineering development of the antisatellite missile was completed. In 1982, tests were carried out on infrared detector units. In 1983, ground simulation tests were carried out. 1984- 1986, 5 flight tests were carried out. After that, due to repeated Congressional opposition, testing was forbidden. In conjunction with that, the project was canceled in 1988.

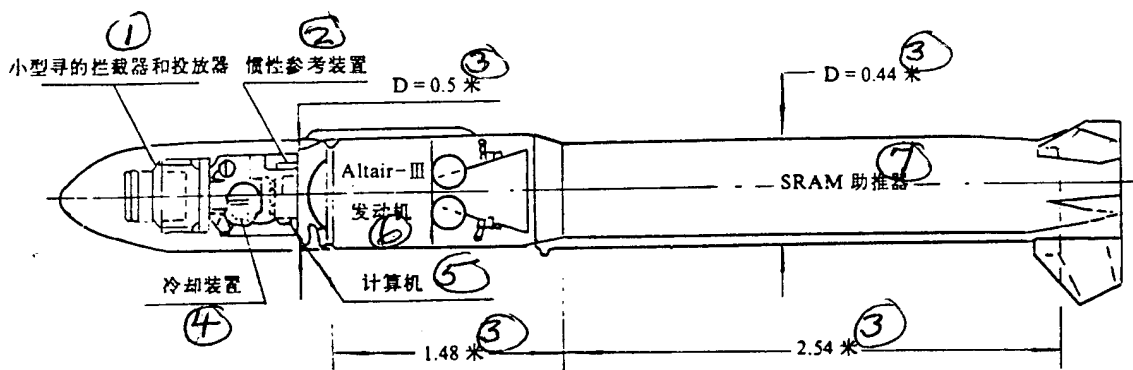

Fig.3 Overall Structural Diagram of Antisatellite Missile

Key: (1) Small Model Homing Interception Device and Launching Device (2) Inertial Reference System (3) Meter (4) Cooling System (5) Computer (6) Engine (7) Booster

(1) Antisatellite Missiles

The overall structural layout of these missiles is as shown in Fig.3. They are composed of a two stage solid rocket with a small homing interception device added to it. A modification of the Boeing company's close range attack missile (SCRAM) solid engine is used as the first stage. It is equipped with three fixed fins and two control fins. The Wode (phonetic) company's Altair-III model solid engine is used as the second stage. It is equipped with an inertial guidance system and turntable. A small model homing interception device produced by the Wode (phonetic) company along with a release system is installed on a turntable at the front end of the second stage. /44

The shape of the small model homing interception device is cylindrical. It is a kinetic energy killing and damaging device using a direct collision killing and damaging mechanism to destroy targets. There is a long wave far infrared sensor device composed of 8 tiny infrared telescopes and a laser gyroscope and microprocessor installed. On the outside peripheral walls, there are installed 56 solid fuel rockets. On the basis of commands from guidance systems, they jet in directions perpendicular to the flight of interception devices in order to supply the crosswise thrusts required in order to hit targets doing flight maneuvers. The small model homing interception device is as shown in Fig.4.

Basic characteristics data on antisatellite missiles:

- Overall missile length 5.43m.

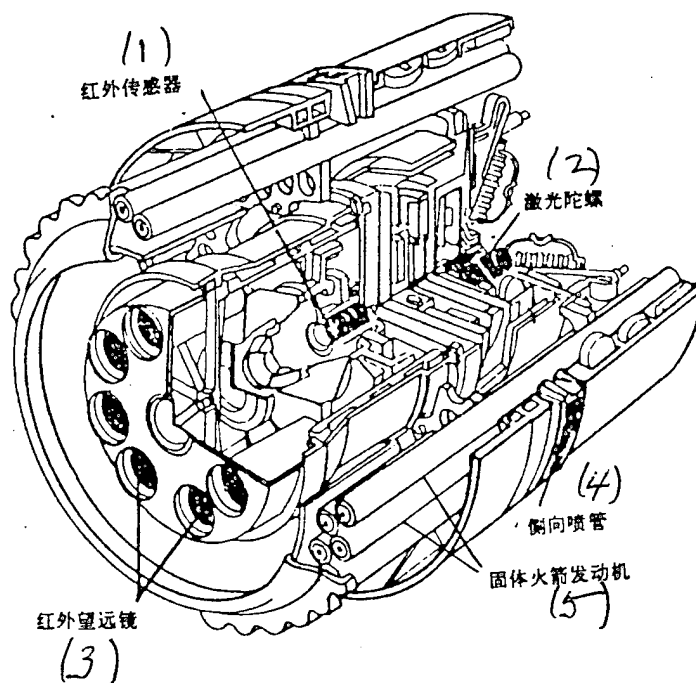

Fig.4 View of Small Model Homing Interception Device

Key: (1) Infrared Sensor (2) Laser Gyroscope (3) Infrared Telescopes (4) Lateral Jet Tubes (5) Solid Fuel Rocket Engines

(2) Combat Operation

Antisatellite missiles are one weapons subsystem of the entire large U.S. antisatellite system. The space monitoring subsystem is the U.S. Sibadasu (phonetic) system. The combat command subsystem is the space defense operations center set up in Cheyenne Mountain.

Antisatellite missiles are carried by F-15 fighters. After receiving an attack command from the Cheyenne Mountain space defense operations center, ground support equipment fixes targets. After the selection of data, F-15's take off. After aircraft enter the launch area, they accelerate. Following that, they turn into a steep straight climb. When the altitude of the climb reaches 10.7-15km, missiles are launched. On the basis of different interception orbits, aircraft are capable of launching in horizontal straight line subsonic flight configurations. They are also capable of launching in configurations of climbing and accelerating to supersonic speeds. After launch, missiles enter into autonomous flight. After second stage engine shut down, /45 covers are thrown off. The turntable at the front end makes small model homing interception devices turn at speeds of 20 turns/minute. Infrared detectors begin searching for targets. After targets are acquired, small model homing devices and missile second stages separate. After that, under the guidance of infrared homing heads, microprocessors carry out timely ignition controls on the 56 small rockets on the periphery of interception devices in order to produce the needed thrust in maneuver directions. Flight trajectories are continuously corrected, making interception devices fly toward targets in completely accurate alignment, right up to collision. The operational method of F-15 antisatellite missiles is direct ascent and head on

intercept. In order to facilitate comparison with Soviet coplanar type interception devices, it is shown in Fig.2(b). The operational process is as shown in Fig.5. F-15 antisatellite flight test status is shown in Table 2.

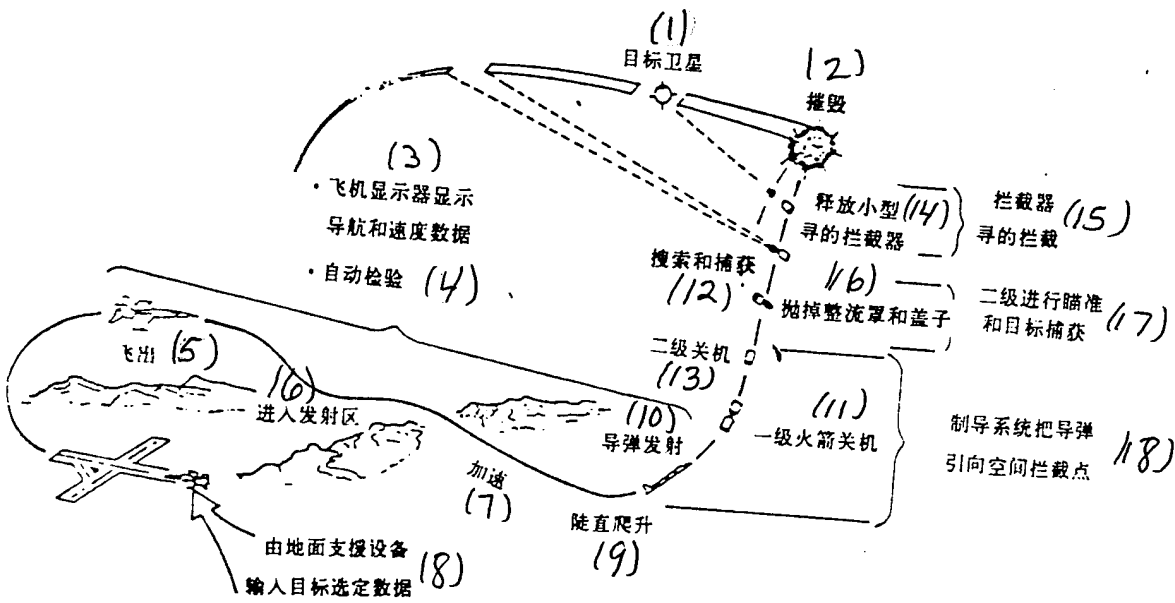

Fig.5 F-15 Antisatellite Missile Operational Process

Key: (1) Target Satellite (2) Destruction (3) Aircraft Display Shows Navigation and Speed Data (4) Automatic Checks (5) Aircraft (6) Entering Launch Zone (7) Acceleration (8) Support from Ground Equipment Inputing Target Selection Data (9) Steep Climb (10) Missile Launch (11) First Stage Rocket Shut Down (12) Search and Acquisition (13) Second Stage Shut Down (14) Release of Small Model Homing Interception Device (15) Interception Device Homing Interception (16) Discard Cowling and Cover (17) Second Stage Enter Aiming and Target Acquisition (18) Guidance System Takes Missile and Leads It to the Space Intercept Point

In actuality, test projects were anything but smooth to carry out. The reason is that very severe splits exist between the U.S. Congress and government and the military on the question of carrying out tests with live missiles to attack real targets. This type of split was given rise to

by the Soviet Union announcing unilaterally in 1983 a temporary halt to antisatellite tests, and, in conjunction with that, that they wanted to stop antisatellite testing with the U.S. and hold bilateral talks. To this end, the U.S. Congress put out a ban to the effect that as long as the Soviet Union continued to voluntarily stop temporarily antisatellite weapons tests, the U.S. would also not be obliged to carry out antisatellite tests on space targets.

The ban gave the military a heavy blow. However, they also dare not discard the original tests. Therefore, in 1986, they carried out live missile firing tests numbers 4 and 5, during which, the original plan was taken and option was made for the use of the installation of radar and infrared measurement devices. In conjunction with this, it was possible to simulate different target characteristics with metal balloon target satellites. Changing over to tracking a star, tests also were changed to ones of missile infrared sensor systems. After that, tests were then completely stopped.

表 2 F-15 反卫星导弹 5 次飞行试验表

① 次数	② 时间	③ 项目	④ 试验目的	⑤ 试验目标	⑥ 结果
1	1984.1.21	⑦ 导弹未带小型 ⑦ 寻的拦截器	⑫ 战斗机的发射系统和 ⑫ 导弹助推器的性能	17 空间一个点	⑫ 成功
2	1984.11.13	⑧ 导弹带小型 ⑧ 寻的拦截器	⑬ 检验拦截器的 ⑬ 红外探测装置捕获、 ⑬ 跟踪目标的能力	⑮ 一颗恒星	⑮ 部分成功
3	1985.9.13	⑨ 全系统	⑭ 验证反卫星导弹的制导 ⑭ 技术和破坏机理	⑲ 550 公里轨道上的 ⑲ P78-1 卫星	⑲ 成功
4	1986.8.22	⑩ 全系统	⑮ 验证红外导引 ⑮ 头的热敏性能	⑳ 一颗恒星，比前次 ⑳ 更接近地平线	⑳ 成功
5	1986.9.30	⑪ 全系统	⑯ 验证红外导引头的 ⑯ 寻的和跟踪能力	㉑ 一颗恒星，比第四次 ㉑ 更接近地平线	㉑ 成功

Table 2 Table for 5 F-15 Antisatellite Missile Flight Tests

Key: (1) Order No. (2) Time (3) Item (4) Test Objective (5) Test Target (6) Results (7) Missile Not Carrying Small Model Homing Interception Device (8) Missile Carrying Small Model Homing Interception Device (9) Full System (10) Full System (11) Full System (12) Fighter Launched System and Missile Booster Performance (13) Check Interception Device Infrared Detection System Acquisition and Target Tracking Capabilities (14) Empirically Verify Antisatellite Missile Guidance Technology and Destruction Mechanisms (15) Empirically Verify Infrared Guidance Head Thermal Sensitivity Characteristics (16) Empirically Verify Infrared Guidance Head Homing and Tracking Capabilities (17) One Point in Space (18) A Star (19) P78-1 Satellite in 550 Km Orbit (20) A Star Even Closer to the Horizon Than the Previous Time (21) A Star Even Closer to the Horizon Than the Fourth Time (22) Success (23) Partial Success

Congress' ban postponed the progress of the F-15 antisatellite missile project, making the original project objective of possessing a preliminary operational capability in early 1987 and a complete operational capability in 1989 not to be realized. The original project procurement amounts were also reduced by two thirds. Antisatellite missile deployment bases also were changed from two to one (Langley Air Force Base).

With regard to Congress' antisatellite test ban, the government and the military held opposite attitudes. Although President Reagan accepted the ban, he still promoted, however, the actual setting up of the antisatellite missile system project. In conjunction with this, right along, he was seeking to resume the tests. Moreover, in February 1987, he approved the U.S. Air Force's newly drawn up antisatellite weapons development plan. The attempt was to make the U.S., in the early 1990's, possess a definite antisatellite capability, and, by the middle and end of the 1990's, to possess stronger and broader antisatellite capabilities. This project included three items. 1. Continuing testing of on hand F-15 antisatellite measures. Due to the fact that, during the first 5 tests, there was only one test directed at an actual target, therefore, the new plan required that 3 tests must be carried out in 1988 attacking actual space satellite targets. 2. Through opting for the use of new engines, antisatellite missile firing altitudes were increased one fold. There were two designs selected. One type was still fired from F-15 aircraft. However, it used boosters with greater thrusts to replace the original missile's first stage. Another type was to use a "Pershing II" missile engine to replace the original first stage, changing to ground launch. 3. Ground based laser antisatellite weapons

were to be studied. However, good times do not last long. F-15 antisatellite projects were, in the end, opposed repeatedly by Congress, and canceled as well because of the existence of problems in technological capabilities and excessive expenditures.

F-15 air launched antisatellite missiles possess such characteristics as small volumes, light weights, agile maneuverability, fast reactions, high hit accuracies, and so on. This then presents difficulties to the enemy's detection, early warning, and attacks. Compared to the Soviet's coplanar type interception devices, the technology is more advanced. Besides this, the range of aircraft in air launched antisatellite missile operations is larger. Under general conditions, F-15 fighter flight radii are 2500km. If in flight refueling is carried out, the flight radius can reach 7500km. If one uses ship borne aircraft, it is then possible to take this type of antisatellite weapon and take it almost anywhere in the world. This then supplies convenient conditions for real time selection of targets, launch times, and positions which has advantages for seizing combat opportunities. Once the weapons in question are put into use, they will pose a very great threat to Soviet satellites moving in low earth orbits.

The U.S. has also considered taking small model homing interception devices and installing them on such large scale rocket boosters as Delta, Titan, and so on, in order to make them capable of reaching altitudes of geosynchronous orbits.

3. Kinetic Energy and Directed Energy Antisatellite Projects

In November 1989, in the "National Space Policy" report, President Bush pointed out that: "The U.S. will develop and deploy a type of broad antisatellite capability

including kinetic energy and directed energy weapons." On the basis of this spirit, the U.S., after canceling the F-15 antimissile project, had the Defense Department approve taking kinetic energy and directed energy weapons as the content of development projects. In conjunction with this, a combined antisatellite office for the three services was organized, commanded by the Army's strategic defense headquarters. This project includes developing near term deployment of ground based kinetic energy antisatellite weapons and directed energy antisatellite weapons for long term applications.

This type of project has two special characteristics. One is development by the three services together. This is due to each service controlling a part of the U.S. space monitoring network. In antisatellite operations, the three services of Army, Navy, and Air Force are capable of operating together. Jointly, they implement detection, identification, and tracking of targets. The three services combine to operate the current monitoring and detection system. This is an advantage for the test manufacture and development of antisatellite weapons. The second is maintaining the development of the two types of antisatellite weapons--kinetic energy and directed energy. This is because the two different types of technology are capable of mutually complementing each other. Directed energy weapons are capable of carrying out "soft kills" on satellites, that is, it is not necessary to destroy satellites. Just going through irradiation by directed energy weapons makes enemy satellite detectors go blind. Photoelectronic components malfunction, leading to satellite operational malfunction. However, weather is capable of severely influencing the utilization of laser antisatellite weapons. However, kinetic energy intercept shells are capable of use in all weather operations and are easy to

determine kill and damage results for. As a result, it is capable of acting as a complement for directed energy weapons. Besides that, compared to kinetic energy weapons, the firing expenses associated with directed energy weapons are also comparatively cheap. The two points above also are the explanation for the U.S. antisatellite projects having already begun directions of development associated with the simultaneous existence of multiple types of weapons and the simultaneous participation of multiple services.

Following along with that, in the last few years, the instability of the world situation, the constant changes in the U.S.-Soviet relationship, detente, and, in particular, the break up of the Soviet Union, as well as the Russian President Yeltsin putting forward a suggestion in 1992 to cancel antisatellite weapons systems make the basic unceasing domestic U.S. debate on the questions of antisatellite weapon development become even more intense, leading to this project going through several revisions. The general trend is toward a great reduction in expenditures. The pace has very, very greatly slowed. Development scales are getting smaller and smaller. In conjunction with this, according to material in the most recent reports, the U.S. Army figures in 1993 to end kinetic energy antisatellite weapon projects.

This article omits the development status of kinetic energy and directed energy antisatellite weapons.

Besides the several types of antisatellite weapons introduced above, the U.S. space shuttle, space station, and electromagnetic rail guns as well as theater missile defense systems (TMD) and airborne laser TMD systems, and so on, developed in SDI projects and used in strategic missile defense all also possess antisatellite capabilities.

IV. THE STRUGGLE BETWEEN THE U.S. AND THE SOVIETS WITH REGARD TO THE ANTISATELLITE ARMS CONTROL TREATY

The competitive development by the U.S. and the Soviets of military satellites and antisatellite weapons causes the outer space arms race to escalate step by step. Speaking then in terms of antisatellite weapons, despite the fact that both sides have held talks, the arms race has, however, increased without reduction. In reality, a number of treaties have already been signed--for example, the 1967 "Outer Space Treaty" and the 1972 "Antiballistic Missile Treaty". These are capable directly or indirectly of protecting satellites, avoiding their meeting with antisatellite weapon attacks. Although they are not specialized antisatellite treaties, a number of articles, however, also possess limited roles with regard to antisatellite development. Speaking in terms of reality, antisatellite weapon development is a violation of the spirit of the two treaties discussed above.

In the 1970's and 1980's the U.S. and the Soviets held talks on the problem of prohibiting antisatellite weapons. However, due to the fact that both sides were setting out from their own advantage, sincerity was lacking. The talks were nothing more than a kind of means for preserving one's own superiority and limiting the development of the opponent, leading to talks not achieving real progress at all. A formal treaty to prohibit antisatellite weapons was not signed either.

With regard to the struggle of the U.S. and the Soviets for a treaty to prohibit antisatellite weapons, there are

the points of view below.

1. Use One's Own Actual Strength to Act as a Chip in Bargaining on the Negotiating Table

From the 1960's to the middle 1970's, the U.S. did not give adequately serious attention to the development of antisatellite weapons, even to the point of not expressing concern with regard to the Soviet Union carrying out antisatellite interception device tests from 1968-1971 (after that, tests stopped for 4 and a half years). However, in 1976, the Soviet Union renewed antisatellite interception device tests. In conjunction with this, when it was clearly shown that they had already reached an actual combat level, only then did the U.S. feel a disequilibrium in the Soviet antisatellite capabilities and confront a severe threat. Because of this, in March 1977, the U.S. first of all put forward with the Soviet Union the carrying out of antisatellite weapon talks.

From 8-16 June 1978, the first round of "preliminary discussions" were held in Helsinki. From 23 January to 19 February 1979, the second round of talks was held in Bonn. Both sides were striving for talks with "concrete structure" and made symbolic efforts. From 23 April to 17 June 1979, the third round of talks was held in Vienna (this was before the highest level meetings of the second strategic weapons limitations talks). It was hoped to be able to draft an antisatellite weapon agreement. In conjunction with that, the strategic arms limitations talks (SALT) treaty was signed at the same time.

At that time, due to not having ready made antisatellite weapons, the U.S. was put in an inferior position in terms of real power. On one hand they thought

to achieve limitation of antisatellite weapons through negotiations. On another, they thought to race against time, stepping up the development of antisatellite weapons. This was also the political reason for the F-15 antisatellite project appearing. However, the Soviet Union, by contrast, held a negative attitude toward negotiations. Due to the fact that there existed splits between both sides on the scope of the provisions of the agreement, there was a turning toward debates associated with second stage strategic weapons /48 limitation talks. Later, due to the Soviet Union's invading Afghanistan in 1979, the talks were broken off.

After the 1980's, U.S. development work on antisatellite weapons carried on F-15 aircraft approached completion. In terms of performance, they were better than the Soviet Union's coplanar type antisatellite interception devices. Once deployed, they would pose a very great threat to Soviet satellites distributed in low earth orbit and in large elliptical orbits. The U.S. would achieve superiority in space combat operations. Facing this situation, the Soviet Union felt that antisatellite weapon competition was not advantageous to itself. As a result, it repeatedly called for stopping the outer space arms race in order to block the U.S. achieving a position of superiority in the areas of antisatellite and antiballistic missile defense. In August 1981, at the 36th U.N. General Assembly, the Soviet Union put forward a proposal banning the deployment in outer space of any form of weapon. In December, the U.N. passed a resolution urging the disarmament committee to then limit the expansion of the arms race into space and draft an appropriate treaty. The U.S. immediately expressed opposition. In 1982, at the 37th U.N. General Assembly, the question was put forward again. In conjunction with this, a resolution was passed to "prevent an outer space arms race". The U.S. again vetoed it, continuing to obstruct the

disarmament commission taking action to develop work on this problem. In March 1983, the Soviet Union unilaterally announced that it would stop carrying out antisatellite tests, in conjunction with this, also urging the U.S. to stop antisatellite tests. 5 days later, this draft resolution was referred to the 38th U.N. General Assembly, requesting the signing of a treaty banning the use of military power in outer space or the use of military power to carry out threats as well as prohibiting the use of objects in space to attack targets on the ground. In June 1984, the Soviet Union again proposed with the U.S. to move toward holding bilateral talks on antisatellite weapons. In conjunction with this, they put forward elimination of the antisatellite systems to act as a part of a talks agreement banning all antisatellite weapons.

For close to four years time, the U.S. adopted an attitude of disinterest toward the Soviet Union, declining to accept suggestions relating to stopping the carrying out of antisatellite tests and also not agreeing to move toward holding talks on antisatellite questions. However, come the summer of 1984, the Reagan administration, under coercion from Congress and daily increasing universal pressure, as well as concerns that the worsening of U.S.-Soviet relations would produce influences on the election, gave fresh consideration to attitudes on the question of antisatellite weapons. On 12 March 1985, both sides returned to disarmament talks including antisatellite weapons in them. However, no substantial progress was achieved.

The greatest split in U.S.-Soviet negotiations is over the scope of antisatellite bans. Although the Soviet Union agrees to discuss limits on antisatellite weapons, it advocates a total ban on all space weapons. However, the U.S. still wants to take "antisatellites" and antiballistic missiles and separate them, holding firm to the continuation

of "Star Wars" plans. In conjunction with this, it has proposed that the conditions for limiting antisatellite weapons are still not mature. The U.S. will certainly not abandon antisatellite tests. Obviously, the U.S. position on antisatellite weapons is to block the Soviet Union's developing better performing weapons, but letting the U.S. continue completing F-15 antisatellite plans.

At the same time as the Soviet Union calling for stopping the outer space arms race and stopping antisatellite tests, they have also not relaxed antisatellite weapon development. Booster rockets used to launch coplanar type antisatellite interception devices normally launch a number of other useful loads, using this to definitely guarantee booster rocket reliability and levels of proficiency of launch personnel. Radar nets are monitoring space satellites all the time, in order to grasp the operating status of the nets in question. Interception device component and ground procedure tests are carried out as a rule, and, in conjunction with this, further technological improvements are made on systems. Coplanar type antisatellite interception devices are maintained in a ready for war status right along at the Qiulatanmu (phonetic) launch site. Besides this, the Soviet Union also carries out research on technologies closely related to interception devices--for example, carrying out manned and unmanned flight craft dockings a number of times, at the same time, also intensifying development of other weapons possessing antisatellite capabilities. Without doubt, this will lead to the appearance of a new generation of antisatellite weapons.

2. Inspection Is the Key to Treaties Being Implemented. It Is Also the Thorniest Problem in U.S. Soviet Negotiations

Inspection is the collection, verification, and analysis of intelligence information. In conjunction with this, it is one process to work out whether or not the inspected side is observing the conclusions of arms control treaties. It is also one type of means to force implementation of treaties through the discovery of traces of treaty violations. Treaties without inspection measures have no way of being observed. However, in actual situations, there are a number of articles in treaty provisions which are capable of inspection. By contrast, there are a number which there is no way to inspect. Despite the fact that satellite reconnaissance as well as a number of space installations are important inspection means, it is possible to monitor the other side. However, there are still a number of limitations. Activities such as underground nuclear tests and those within plants and laboratories as well as strategic weapons making use of camouflaged deployments cannot be observed from space. There is no way to inspect them. During U.S.-Soviet negotiations on banning antisatellite weapons, the thorniest problem is inspection. The U.S. puts great stress on inspection. In March 1984, during a U.S. government policy report submitted to Congress relating to antisatellite weapon control, Reagan declared: "There are many reasons making it impossible to consider effective antisatellite arms control measures--for example, the particular difficulties of inspection." The attitude of the U.S. in negotiations is, on the one hand, to stress inspection, and, on the other hand, to also often use the inadequacy of inspection as an excuse to reject conditions it is not willing to accept. The U.S. recognizes that testing and deployment of antisatellite weapons in violation of treaties is almost impossible to detect. The reason is that there are many legal space activities which are all capable of opting for the use of antisatellite technology. Banning

antisatellite technology with no way to inspect will only limit the U.S. and not the Kremlin because the Soviet Union already has actual combat antisatellite weapons.

3. Mutual Suspicions and Mistrust Are a Great Obstacle to U.S.-Soviet Talks

In 1983, the Soviet Union submitted to the United Nations the provisions for a draft treaty to ban antisatellite weapons in which it was required that antisatellite weapons must not tested, produced, or deployed. In conjunction with this, antisatellite weapons already in existence were eliminated. Toward this, the U.S. held a suspicious attitude. In the U.S. view, canceling systems which already existed was problematical because antisatellite weapon warheads are very small and very easy to hide. There is also no way to concretely verify that these systems have already been eliminated. Talking in terms of the Soviet Union's SS-9 delivery vehicle, the antisatellite weapons and nonantisatellite weapons which it carries have the same outside form. When necessary, nonantisatellite weapons can also be used as antisatellite weapons. The U.S. believes: "Any trickery in the Soviet antisatellite agreement, even though very small, will still carry a high price in risk to the U.S."

4. Prospects for Antisatellite Weapon Arms Control

Following along with further warming in U.S.-Soviet relationships, new trends have been produced in important questions of international relations such as arms control and disarmament. Acting as supplements to national inspection technology means and cooperative international inspection means-- speaking in terms of on site inspections--in the past, the Soviet Union has been concerned right along that the U.S. would make use of on

site inspections to gather intelligence, putting forward the principles that inspections must not violate sovereignty or interfere with internal governance as well as that inspections should be limited. However, after Gorbachev came to power, the Soviet Union opened up to the outside with every passing day. In bilateral treaties, options for the use of on site inspections became more and more numerous. This is also one type of trend in the area of disarmament treaty inspections today.

After the dissolution of the Soviet Union, Russian President Yeltsin unceasingly addressed the problem of having to ban antisatellite weapons. In January 1992, Yeltsin expressed a "declaration of Russian policy in the field of arms limitations and reductions", preparing to destroy currently existing antisatellite systems reciprocally with the U.S. Moreover, an agreement was drawn up relating to total banning of antisatellite weapons. When considering the drafting of an agreement setting up a common U.S-Russian combined defense system, Yeltsin also listed the banning of antisatellite weapons as one of the key items.

People will wait and see whether or not the U.S. can accept Yeltsin's suggestion and whether or not future negotiations on banning antisatellite weapons as well as treaty signings materialize.

V. DISCUSSION AND POINTS OF VIEW

1. Looking from the point of view of the analyses discussed above, the two nations--the U.S. and the Soviet Union--have over 30 years experience in developing antisatellite weapons. They have achieved relatively great progress and already possess the ability to put into operational use or close to actual combat antisatellite

weapons. Speaking comparatively, in terms of combat capabilities, the Soviet Union has already deployed coplanar type antisatellite interception devices which have reached the only real combat level in the world. However, by contrast, the U.S. does not possess this. It only has experience with F-15 antisatellite weapons which have tested successfully a few times. However, these have still not reached real combat capabilities. Technologically speaking, due to the U.S. advantage in computers and microelectronics technology, it has been determined that it is in a position of leadership compared to the Soviet Union in the field of antisatellite technology. In terms of the threatening nature of antisatellite weapons, due to most U.S. satellites--for example, warning, communications, navigation, and other such key satellites--all being in geosynchronous orbits, Soviet coorbital type antisatellite interception devices which are only capable of attacking low earth orbit satellites do pose a certain threat to U.S. military satellites. However, there is no great threat. By contrast, most Soviet satellites are distributed in low earth orbit. If U.S. F-15 borne antisatellite weapons development is successful, then, it will pose a very great threat to the Soviet Union. However, in another area, the Soviet Union also possesses relatively strong capabilities to launch and replace satellites. In time of crisis, they are capable of quickly replacing malfunctioning satellites, thereby also making up for this point.

2. It is necessary to point out that the antisatellite weapons which the U.S. and the Soviet Union have already developed or are in the midst of developing--no matter whether they are coorbital types, straight ascent types, or kinetic energy and directed energy weapons--at the present time, are still only capable of handling low earth orbit satellites. With regard to interception problems associated with satellites for such things as communications, warning,

navigation, and so on, placed in geosynchronous orbits and playing key roles in modern military power, they have still not been resolved. To this end, space shuttles, space stations, high energy lasers, particle beam weapons, as well as space mines and so on, may be effective ways to resolve this problem.

/50

3. The same as ballistic missile technology, satellite launch technology is also in the midst of an expansion on a world scale. Besides the U.S. and the Soviet Union, third world countries and regions such as Brazil, India, Iraq, Israel, South Korea, and Taiwan have already mastered or will soon master ballistic missile and satellite launch technology. This technology will make these nations or regions possess the conditions to develop direct ascent type antisatellite weapons. At the same time, it will also bring new factors for world instability.

4. On 13 May 1993, U.S. Defense Secretary Aspen announced that the U.S. hereafter will take its strategic defense focus and turn it from space missile defense to ballistic missile defense. In conjunction with this, the Strategic Defense Initiative Office (SDIO) will change its name to the Ballistic Missile Defense Office (BMDO). This then announced that the "Star Wars" plan, which spent 33 billion U.S. dollars over 10 years, was over-- following the break up of the Soviet Union. At the same time, Aspen also put forward the fact that states committing terrorist activities would be able, within 10 years, to acquire capabilities in nuclear weapons and missiles, to hit the U.S., posing a threat. Therefore, antimissile defense is still necessary. Very obviously, U.S. military strategic targets, from here on, will turn from mainly aimed at the Soviet Union to third world countries.

5. Following the break up of the Soviet Union and the end of Star Wars, the international situation will turn toward directions of development advantageous to detente. What influences will this produce on the test production and development of future antisatellite weapons? What are the prospects for antisatellite weapon arms control treaty negotiations? At the present time, it is still very difficult to make accurate judgments. However, there is a point which can be confirmed. Various types of factors in the world, leading to unrest and tensions in the situation, have not disappeared. As long as military satellites are operating in space, the space arms race will not stop. Such countries as the U.S. and Russia will then certainly not abandon the development of antisatellite weapons, even if a certain antisatellite project stops--for instance, the U.S. kinetic energy antisatellite weapons project. However, research on basic technologies related to countering satellites will certainly not stop. On the contrary, it will increase without a let up.

In view of the analysis above, in a space defense strategy including antisatellite weapons, China should adopt corresponding policies. The partial contents of these we will elucidate in another article.

REFERENCES

- [1] Major Mark S. Peacock. "Ground and Space-Based Security". Military Review. Oct. 1992, pp.55-64.
- [2] Richard L. Garwin et al. "Antisatellite Weapons". Scientific American. Jun. 1984, pp.27-37.
- [3] Dr Josephine Anne Stein. "Satellites. Anti-Satellite Weapons and Security". RUSI Journal Winter 1988. pp.48-54.
- [4] Eric Raiten kasta Tsipis, "Conventional Anti-Satellite Systems", Mar. 1984.
- [5] Paul B. Stares, "Space and National Security", The Brookings Institution, 1987.
- [6] "Russians Alter MIG-31 for ASAT Carrier Role", AW & ST Dec. 7, 1992. p.63.
- [7] Barry R Schneider et al, "The Soviet Military Space Programs", Signal, May 1988, pp.61-67.
- [8] John H. Gibbons et al., "Anti-Satellite Weapons. Countermeasures and Arms Control", 1985.

- [9] Craig Covault, "Antisatellite Weapon Design Advances", AW & ST, June 6, 1980, pp.243-245.
- [10] "USAF Knocks Down Satellite", Flight International, 21 Sep. 1985, p.2.
- [11] General John L. Piotrowski, "A Joint Effort", Proceedings, Feb. 1990, pp.33-36.
- [12] James T. Hackett et al, "Proliferating Satellites Drive U.S. ASAT Need", Signal, May 1990, pp.155-160.
- [13] "U.S. Antisatellite Weapons Begin Demonstration Phase", Signal, June 1990, pp.45-47.
- [14] J.Stegmaier et al, "Kinetic Energy Anti-Satellite Weapon System", AIAA Space Programs and Technologies Conference, March 24-27, 1992.

151

- [15] Peter Borgart, "Soviet Military Space Programs", IDR. 1 / 1990, pp.23-26.
- [16] General John L. Piotrowski, "A Soviet Space Strategy", Strategic Review, Fall 1987, pp.55-62.
- [17] "Anti-Satellite Weapon System / Kinetic Energy ASAT", DMS, April 1993.
- [18] "Defense Hardliners Shift Support from Bush to Clinton", Defense News, Oct.12-18, 1992, p.68.
- [19] "Army Anti-Satellite Program Slashed", Military Space - July 13, 1992, pp.7-8.
- [20] Robina Riccitiello, "U.S. Military Cuts Back ASAT, Surveillance Program", Space News Feb. 3-9, 1992.
- [21] Neff Hudson, "Air Force ASAT Research Goes on Unabated", Space News, April 26-May 2, 1993.
- [22] 孙万林, "战略激光武器", 现代军事, 1990年第10期, 第42~44页。
- [23] Borry R. Schneider et al, "The Soviet Military Space Program", Signal, Dec. 1984, pp.69-73.
- [24] "Space Weapons and International Security", Oxford University Press, 1987.
- [25] Capt. Gregory C. Radabaugh, "Soviet Antisatellite Capabilities", Signal, Dec.1988, pp.81-84.
- [26] 孙鸿章编译, "美国的星球大战"计划, 国外卫星动态, 1985年增刊, 第1~13页。
- [27] Gen. John L. Piotrowski, "Why the U.S Needs an Antisatellite", National Defense, Feb. 1990, pp.36-39.
- [28] 刘华秋, "裁军理论浅析", 现代军事, 1991年第1期, 第22~24页。
- [29] 程不时等译, "星球大战", 上海科学普及出版社, 1988年。
- [30] Matthew Bunn, "The ABM Talks: The More Things Change ...", Arms Control Today, Sem. 1992, pp.15-16.
- [31] Keith B. Payne et al, "Evolving Russian Views on Defense: An Opportunity for Cooperation", Strategic Review, 1993 Winter, pp.64-65.
- [32] "美国宣布'星球大战时代'结束", 参考消息, 1993年5月16日。

DISTRIBUTION LIST

DISTRIBUTION DIRECT TO RECIPIENT

<u>ORGANIZATION</u>	<u>MICROFICHE</u>
B085 DIA/RTS-2FI	1
C509 BALLOC509 BALLISTIC RES LAB	1
C510 R&T LABS/AVEADCOM	1
C513 ARRADCOM	1
C535 AVRADCOM/TSARCOM	1
C539 TRASANA	1
Q592 FSTC	4
Q619 MSIC REDSTONE	1
Q008 NTIC	1
Q043 AFMIC-IS	1
E404 AEDC/DOF	1
E410 AFDTC/IN	1
E429 SD/IND	1
P005 DOE/ISA/DDI	1
1051 AFIT/LDE	1
PO90 NSA/CDB	1

Microfiche Nbr: FTD95C000613L
NAIC-ID(RS)T-0263-95