



**US Army Corps
of Engineers**
Waterways Experiment
Station

Instruction Report ITL-95-1
August 1995

Computer-Aided Structural Engineering (CASE) Project

User's Guide: Computer Program for the Design and Investigation of Horizontally Framed Miter Gates Using the Load and Resistance Factor Design Criteria (CMITER-LRFD)

by Guillermo A. Riveros

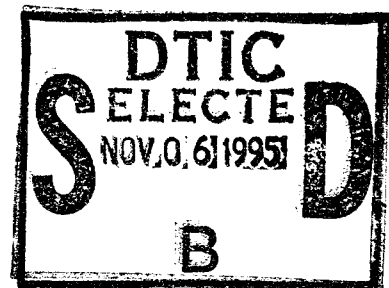

DTIC SELECTED
NOV. 0. 61 1995
B

Approved For Public Release; Distribution Is Unlimited

19951103 021

DTIC QUALITY INSPECTED 1

REPORT DOCUMENTATION PAGE

Form Approved
OMB No. 0704-0188

Public reporting burden for this collection of information is estimated to average 1 hour per response, including the time for reviewing instructions, searching existing data sources, gathering and maintaining the data needed, and completing and reviewing the collection of information. Send comments regarding this burden estimate or any other aspect of this collection of information, including suggestions for reducing this burden, to Washington Headquarters Services, Directorate for Information Operations and Reports, 1215 Jefferson Davis Highway, Suite 1204, Arlington, VA 22202-4302, and to the Office of Management and Budget, Paperwork Reduction Project (0704-0188), Washington, DC 20503.

1. AGENCY USE ONLY (Leave blank)	2. REPORT DATE August 1995	3. REPORT TYPE AND DATES COVERED Final report	
4. TITLE AND SUBTITLE User's Guide: Computer Program for the Design and Investigation of Horizontally Framed Miter Gates Using the Load and Resistance Factor Criteria (CMITER-LRFD)		5. FUNDING NUMBERS	
6. AUTHOR(S) Guillermo A. Riveros		7. PERFORMING ORGANIZATION NAME(S) AND ADDRESS(ES) U.S. Army Engineer Waterways Experiment Station 3909 Halls Ferry Road, Vicksburg, MS 39180-6199	
8. PERFORMING ORGANIZATION REPORT NUMBER Instruction Report ITL-95-1		9. SPONSORING/MONITORING AGENCY NAME(S) AND ADDRESS(ES) U.S. Army Corps of Engineers Washington, DC 20314-1000	
10. SPONSORING/MONITORING AGENCY REPORT NUMBER		11. SUPPLEMENTARY NOTES Available from National Technical Information Service, 5285 Port Royal Road, Springfield, VA 22161.	
12a. DISTRIBUTION/AVAILABILITY STATEMENT Approved for public release; distribution is unlimited.		12b. DISTRIBUTION CODE	
13. ABSTRACT (Maximum 200 words) This report is the user's manual for the CMITER-LRFD computer program, which is used to design and investigate horizontally framed miter gates with the skin plate in the upstream flange, using the load and resistance factor design criteria (LRFD). LRFD criteria offer more uniform reliability and a possibility of economy that is achieved in the design process. CMITER-LRFD is organized into three distinct functions: the Recommended Design Module (RECDES), which performs calculations that will help to establish meaningful values required to start the design; the Design Module (DES), which performs calculations to design a gate leaf; and the Investigation Module (INV), which can be used to investigate an existing gate leaf or to verify a design. This report presents results of RECDES, DES, and INV modules for an example of a structure originally designed using allowable stress design criteria.			
14. SUBJECT TERMS Computer program Horizontally framed miter gates		Hydraulic steel structures Load and resistance factor design	
15. NUMBER OF PAGES 214		16. PRICE CODE	
17. SECURITY CLASSIFICATION OF REPORT UNCLASSIFIED	18. SECURITY CLASSIFICATION OF THIS PAGE UNCLASSIFIED	19. SECURITY CLASSIFICATION OF ABSTRACT	20. LIMITATION OF ABSTRACT

The contents of this report are not to be used for advertising, publication, or promotional purposes. Citation of trade names does not constitute an official endorsement or approval of the use of such commercial products.

Accession For	
NTIS GR&I	<input checked="" type="checkbox"/>
DTIC TAB	<input type="checkbox"/>
Unannounced	<input type="checkbox"/>
Justification	
By _____	
Distribution _____	
Availability Codes	
Dist	Avail and/or Special



PRINTED ON RECYCLED PAPER

User's Guide: Computer Program for the Design and Investigation of Horizontally Framed Miter Gates Using the Load and Resistance Factor Design Criteria (CMITER-LRFD)

by **Guillermo A. Riveros**

**U.S. Army Corps of Engineers
Waterways Experiment Station
3909 Halls Ferry Road
Vicksburg, MS 39180-6199**

Final report

Approved for public release; distribution is unlimited



**US Army Corps
of Engineers**
Waterways Experiment
Station

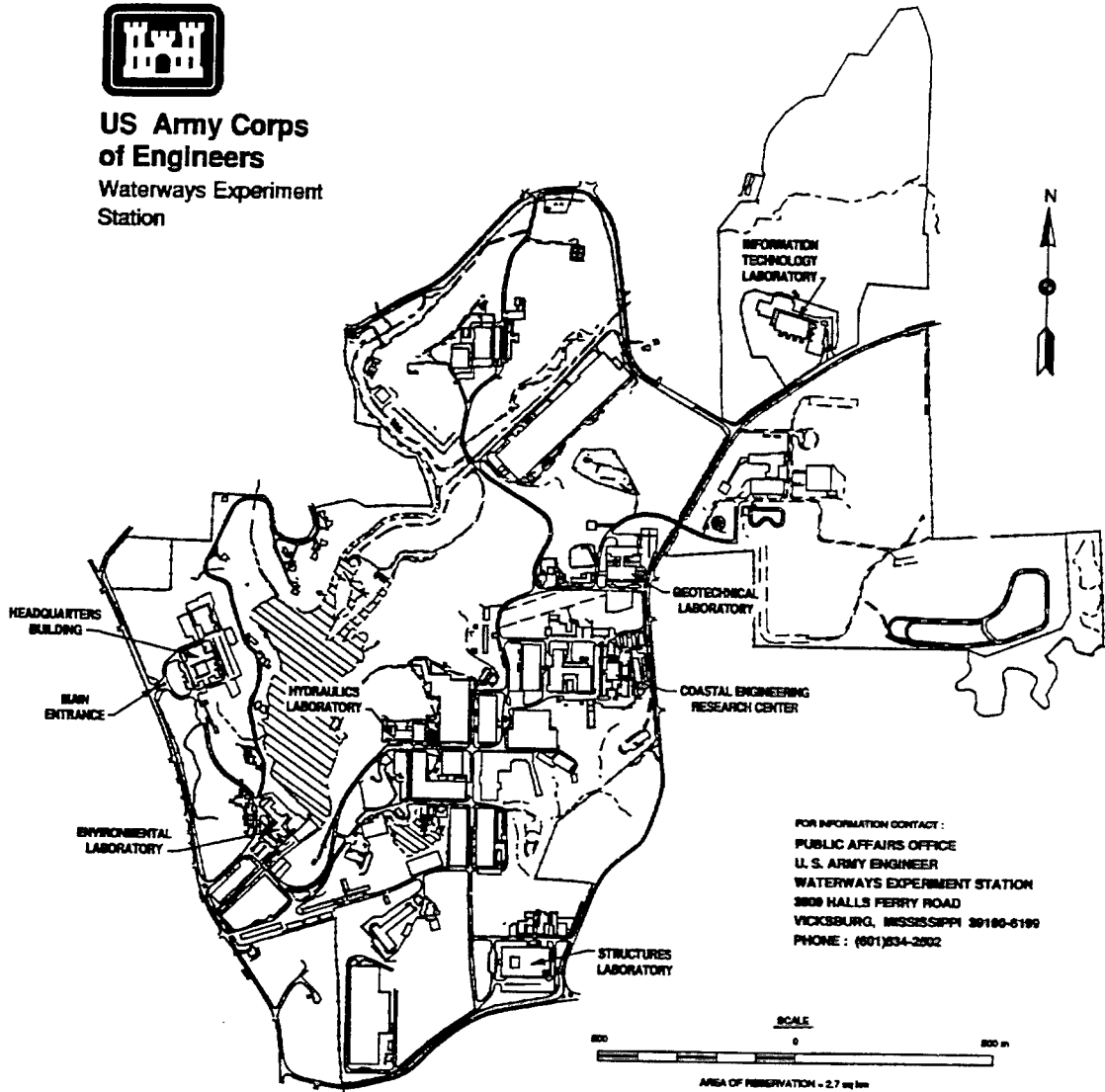

FOR INFORMATION CONTACT :
PUBLIC AFFAIRS OFFICE
U. S. ARMY ENGINEER
WATERWAYS EXPERIMENT STATION
3809 HALLS FERRY ROAD
VICKSBURG, MISSISSIPPI 39180-6199
PHONE : (601)834-2502

Waterways Experiment Station Cataloging-in-Publication Data

Riveros, Guillermo A.

User's guide : computer program for the design and investigation of horizontally framed miter gates using the load and resistance factor design criteria (CMITER-LRFD) / by Guillermo A. Riveros ; prepared for U.S. Army Corps of Engineers.

214 p. : ill. ; 28 cm. — (Instruction report ; ITL-95-1)

Includes bibliographic references.

1. Hydraulic gates — Computer programs — Handbooks, manuals, etc. 2. Locks (Hydraulic engineering) — Computer programs. 3. Hydraulic structures — Computer programs. I. United States. Army. Corps of Engineers. II. U.S. Army Engineer Waterways Experiment Station. III. Information Technology Laboratory (U.S. Army Engineer Waterways Experiment Station) IV. Computer-aided Structural Engineering Project. V. Title. VI. Title: Computer program for the design and investigation of horizontally framed miter gates using the load and resistance factor design criteria (CMITER-LRFD). VII. Series: Instruction report (U.S. Army Engineer Waterways Experiment Station) ; ITL-95-1.

TA7 W34i no.ITL-95-1

Contents

Preface	vi
Conversion Factors, Non-SI to SI Units of Measurement	viii
1—Introduction	1
Background	1
Design Criteria	4
Objectives	4
2—Load and Resistance Factor Design Criteria For Miter Gates	6
Scope	6
Design Basis	6
Gate Properties	7
Loads and Reactions	7
Analysis Procedure	13
3—Program CMITER-LRFD General Description	38
Scope	38
Description	38
Analysis Sequence	40
4—CMITER-LRFD Input Files	42
Group I	42
Group II	48
Group III	53
Group IV	59
5—Example Problem	62
Scope	62
Example, Lower Miter Gate	62
Hand Calculations	70
References	96
Appendix A: Example Problem Program Results	A1

List of Figures

Figure 1.	Downstream view of basic structural elements of horizontally framed miter gate	2
Figure 2.	Downstream view of detailed structural elements of horizontally framed miter gate	2
Figure 3.	Top view of tapered end section of horizontally framed miter gate	3
Figure 4.	Front view of vertically framed miter gate	3
Figure 5.	Hydrostatic loads acting on the horizontally framed miter gate	8
Figure 6.	Impact loads for miter gate girders	9
Figure 7.	Intercostal sections	15
Figure 8.	Intercostal loading diagram	16
Figure 9.	Girder reactions	25
Figure 10.	Girder flange data	27
Figure 11.	Tapered end critical section	28
Figure 12.	Tapered end load distribution	29
Figure 13.	Diaphragm loads	30
Figure 14.	Thrust diaphragm, axial load calculation	31
Figure 15.	Quoin post layout	33
Figure 16.	CMITER-LRFD program organization	38
Figure 17.	Downstream view of the gate; values calculated by RECDDES module	39
Figure 18.	Group I	43
Figure 19.	Group II	50
Figure 20.	Group III, quoin, tapered end, and end diaphragm data	55
Figure 21.	Group III, diagonals	56

Figure 22.	Vertical cross section	63
Figure 23.	Top view girder	64
Figure 24.	Intercostal section	66
Figure 25.	Plate girder investigation points	70
Figure 26.	Girder cross section	76
Figure 27.	End diaphragm section	82
Figure 28.	Quoin post section	85
Figure 29.	Thrust diaphragm section	87
Figure 30.	Tapered end section	90
Figure 31.	Plan and elevation views of the gate, diagonals	92

List of Tables

Table 1.	Width-to-Thickness Ratios	18
Table 2.	Data File Group I	44
Table 3.	Data File Group II	49
Table 4.	Data File Group III	54
Table 5.	Data File Group IV	59
Table 6.	Girder Unfactored Loads	71
Table 7.	Girder Load Combinations	71
Table 8.	Panel Unfactored Loads	72
Table 9.	Panel Load Combinations	72
Table 10.	Gate Torsion Loads	92

Preface

This report presents the user's manual for CMITER-LRFD computer program to design and investigate horizontally framed miter gates using load and resistance factor design (LRFD) criteria. Funding for the development of the program and preparation of this report was provided to the Scientific and Engineering Applications Center (S&EAC), Computer-Aided Engineering Division (CAED), Information Technology Laboratory (ITL), U.S. Army Engineer Waterways Experiment Station (WES), Vicksburg, Mississippi, by Headquarters, U.S. Army Corps of Engineers (HQUSACE), under the Computer-Aided Structural Engineering (CASE) Project.

Specifications for the computer program were prepared by the members of the Steel CASE task group. Members of the task group during the development of the program included:

Eugene A. Ardine, Ohio River Division
Cameron Chasten, Philadelphia District
Ray Dewey, Portland District
Joe Hartman, HQUSACE
Nathan Kathir, St. Paul District
Tom Ruf, St. Louis District
Henry Stewart, North Central Division
William Wigner, Jacksonville District
Tom Wirtz, Rock Island District
Joe Padula, WES
H. Wayne Jones, WES
Guillermo A. Riveros, WES

The computer program and this report were written by Mr. Guillermo A. Riveros, WES, under the supervision of Mr. H. Wayne Jones, Chief, S&EAC, Dr. Reed Mosher, Chief, CAED, and Dr. N. Radhakrishnan, Director, ITL.

At the time of publication of this report, Director of WES was
Dr. Robert W. Whalin. Commander was COL Bruce K. Howard, EN.

*The contents of this report are not to be used for advertising, publication,
or promotional purposes. Citation of trade names does not constitute an
official endorsement or approval of the use of such commercial products.*

Conversion Factors, Non-SI to SI Units of Measurement

Non-SI units of measurement used in this report can be converted to SI units as follows:

Multiply	By	To Obtain
feet	0.3048	meters
inches	0.0254	meters
kips	4.448	kilonewtons
kips per square foot	47.88026	kilopascals
kips per square inch	6894.757	kilopascals
pounds (force) per square inch	0.006894757	megapascals
pounds (mass) per cubic foot	16.01846	kilograms per cubic meter
square feet	0.09290	square meters
tons	907.185	kilograms

1 Introduction

Background

Lock gates serve several different functions, depending on locations and conditions. The major use of lock gates is to form a damming surface across a lock chamber, but the gates may also be used to serve as guard gates, to fill and empty a lock chamber, to allow ice and debris to pass, and to provide access from one lock wall to the other by means of walkways or bridgeways installed on top of the gates. A navigation lock requires closure gates at both ends of the lock so the water level in the lock chamber can be varied to coincide with the upper and lower approach channels. Many locks in the United States are equipped with double-leaf miter gates that are used for moderate and high-lift locks, with a height of 20 to 80 ft¹ and a chamber width of 56 to 110 ft. These gates are fairly simple in construction and operation and can be opened or closed more rapidly than any other type of gate. Maintenance costs are generally low.

Miter gates are framed either horizontally or vertically. The skin plate of a horizontally framed gate is supported by horizontal members that may be either straight girders acting as beams, or circular arches (Figure 1). Each horizontal member is supported by a vertical quoin post at one end and a miter post at the other (Figures 1-3).

A vertically framed gate resists the water pressure by a skin plate supported on a series of vertical girders almost uniformly spaced along the length of the gate. The vertical girders are supported at the top and bottom by horizontal girders that transmit the loads to miter and quoin at the top of the leaf and directly to the sill at the bottom (Figure 4). Due to the greater rigidity and resistance-to-boat impact of the horizontally framed miter gates and the insignificant difference in cost, vertically framed gates are no longer designed by the U.S. Army Corps of Engineers (USACE) except in unusual applications and with special approval.

¹ A table of factors for converting non-SI units of measurement to SI units is presented on page viii.

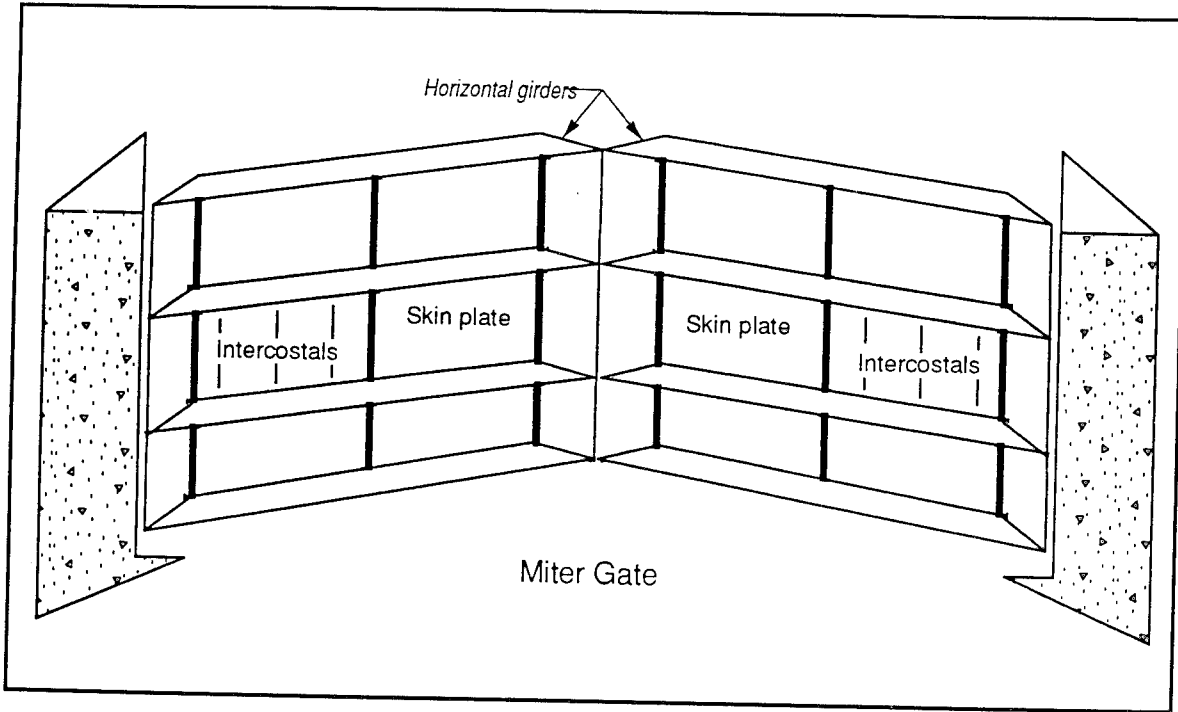

Figure 1. Downstream view of basic structural elements of horizontally framed miter gate

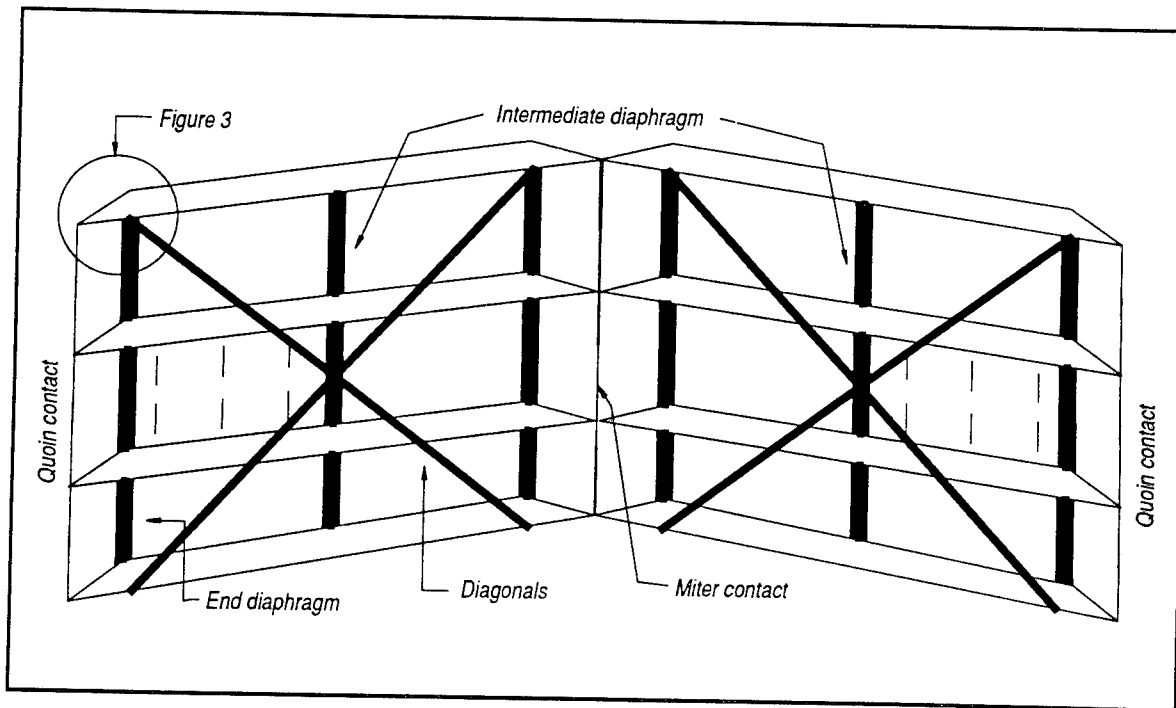

Figure 2. Downstream view of detailed structural elements of horizontally framed miter gate

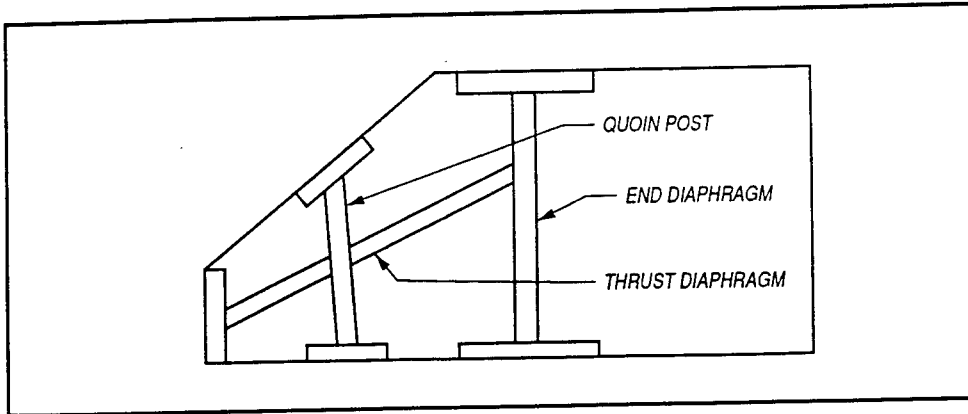

Figure 3. Top view of tapered end section of horizontally framed miter gate

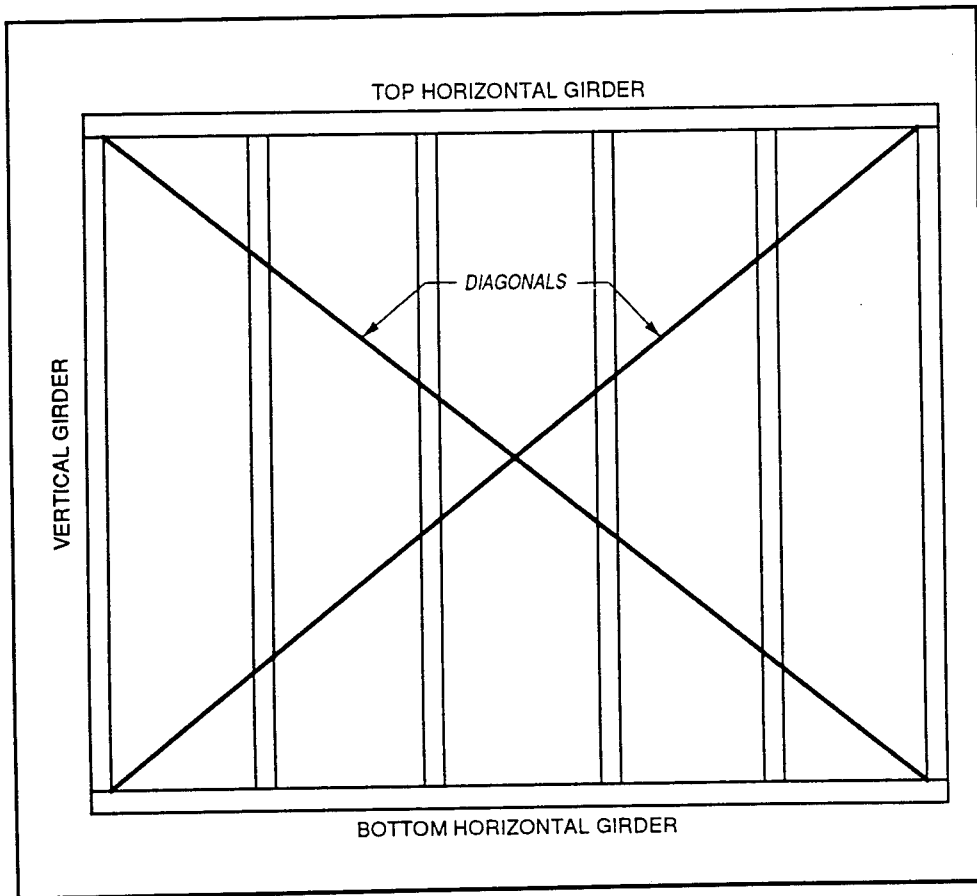

Figure 4. Downstream view of vertically framed miter gate

USACE has designed computer program CMITER for analysis and design of horizontally framed miter gates with the skin plate in the upstream face only. This program comprises three principal modules:

- a. A recommended design module, which suggests girder web depth, girder spacing, and the spacing and sizes of the intercostals.
- b. A design module, which is used to design the basic and detailed gate leaf elements (Figures 1 and 2).
- c. An investigation module, which is used to investigate the integrity of elements in an existing gate.

Design Criteria

CMITER (Headquarters, Department of the Army 1988) is based on allowable stress design (ASD) criteria specified in Engineer Manual (EM) 1110-2-2703 (Headquarters, Department of the Army 1984) and American Institute of Steel Construction (AISC) (1989). In the past, basic guidelines for design of hydraulic steel structures (HSS) have been in accordance with the ASD criteria in EM 1110-2-2703 and AISC (1989). The ASD criteria have usually yielded safe and reliable structures. However, the criteria do not recognize differing variables in loads and resistances. Therefore, to obtain structures with a more uniform reliability, a load and resistance factor design (LRFD) approach (EM 1110-2-2105 (Headquarters, Department of the Army 1992)) has been adopted by most specification writing committees. Criteria in the LRFD approach have two main advantages over the ASD criteria. First, a limit state analysis does not have to follow linearity between load and force, or between force and stress. Second, the application of multiple load factors can be used to reflect the degree of uncertainty for different loads. Also, application of multiple resistance factors reflects differing uncertainties in a particular resistance (bending capacity, shear capacity, etc.). Due to these advantages, more uniform reliability is achieved in the design process.

Objectives

General objectives of the work discussed herein are to:

- a. Update the CMITER program for the analysis and design of horizontally framed miter gates to include the load and resistance factor design specifications established by USACE.
- b. Describe the criteria used in the CMITER-LRFD program to design and investigate the elements in a horizontally framed miter gate.

- c. Present the program's user manual.
- d. Present an example that will help the user generate the input files required by the program.

2 Load and Resistance Factor Design Criteria for Miter Gates

Scope

This chapter presents the criteria used in the CMITER-LRFD program to design and investigate the main structural elements of horizontally framed miter gates. The gates are shown schematically in Figures 1 and 2. The criteria include specifications of applied loads, load cases, load combinations, and analysis methods used in the program. Design methods described herein are in accordance with those given in EM 1110-2-2105 and AISC (1986).

Design Basis

LRFD is a method of proportioning structures in such a manner that no applicable limit state is exceeded when the structure is subjected to all appropriate design load combinations. The basic safety check in LRFD may be expressed mathematically as

$$\Sigma \gamma_i Q_{ni} \leq \alpha \phi R_n$$

where γ_i denotes the load factors that account for variability in the loads to which they are assigned, and Q_{ni} represents nominal (code-specified) load effects. The expression $\Sigma \gamma_i Q_{ni}$ is the required strength. Load factors and load combinations for miter gate design are listed later in this chapter. R_n is the nominal resistance, and ϕ is a resistance factor that reflects the uncertainty in the resistance for the particular limit state and, in a relative sense, the consequence of attaining the limit state. The factor α is a reliability factor of 0.9 for HSS except for the structures described below, for which α is 0.85:

- a. HSS for which inspection and maintenance are difficult because the HSS is normally submerged, and removal of the HSS causes disruption of a larger project. Examples of this type of HSS include tainter valves and leaves of vertical lift gates which are normally submerged.
- b. HSS in brackish water or seawater.

The product $\alpha\phi R_n$ is termed "the design strength for HSS."

Gate Properties

General geometry

The general geometry of horizontally framed miter gates is divided into two groups: basic structural elements that include the skin plate, intercostals, and plate girders that comprise the majority of the weight in the gate (Figure 1); and detailed structural elements that include the tapered-end section, end diaphragms, quoin post, thrust diaphragm, and diagonals (Figure 2).

Structural steel

Lock gates are usually constructed of structural-grade carbon steel having a yield point of 36,000 psi. Low-alloy steel with a yield point up to 50,000 psi may also be used and is frequently used for the skin plate with girders of 36,000-psi steel.

Loads and Reactions

The principal types of loads applicable to miter gate design are gravity, hydraulic, operating, barge impact, and earthquake loads. Reactions and load cases are generally considered in two categories: gate in the open or intermediate position with no pool differential, and leaves mitered and supporting the full hydrostatic load.

Vertical loads

Vertical loads consist of the dead load of the gate, mud, and/or ice.

Hydraulic loads

Hydraulic loads consist of static water load on the gate produced by the pool differential or temporal hydraulic loads (Figure 5).

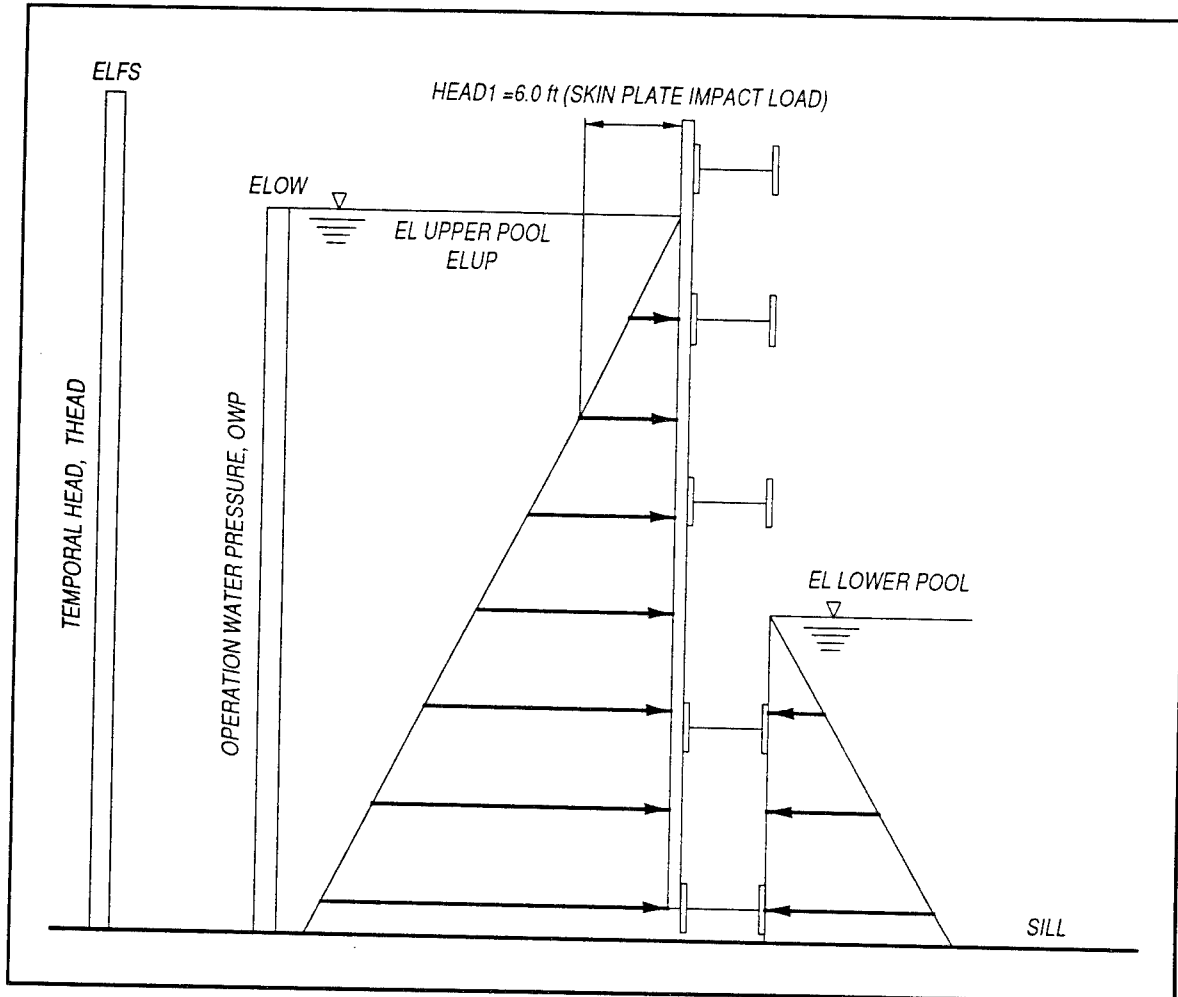

Figure 5. Hydrostatic loads acting on a horizontally framed miter gate

The temporal loads' effect on the gate due to waves, surges, etc., can be evaluated with appropriate conditions selected. A minimum temporal hydraulic load of 1.25 ft acting from the full submergence elevation (ELFS) down to the sill, with a period exceeding 30 sec (thus considered static), is specified in EM 1110-2-2703.

Operating loads

Operating load is the maximum load exerted by the operating machinery (obtained from the mechanical engineer who designed the machinery) and is considered for cases in which the gate is held by a submerged obstruction.

Barge impact loads

A barge impact load is a dynamic load applied to the gate when struck by a barge. The barge impact load is specified as a point load, and it is applied to the girders above the pool level in the downstream direction at the miter point (symmetrical impact), and anywhere in the girder span at which a single barge may impact (unsymmetrical impact) (Figure 6). This location is anywhere in the span at least 35 ft (standard barge width) from either lock wall. The impact load (I) is 250 kips for unsymmetrical loading and 400 kips for symmetrical loading.

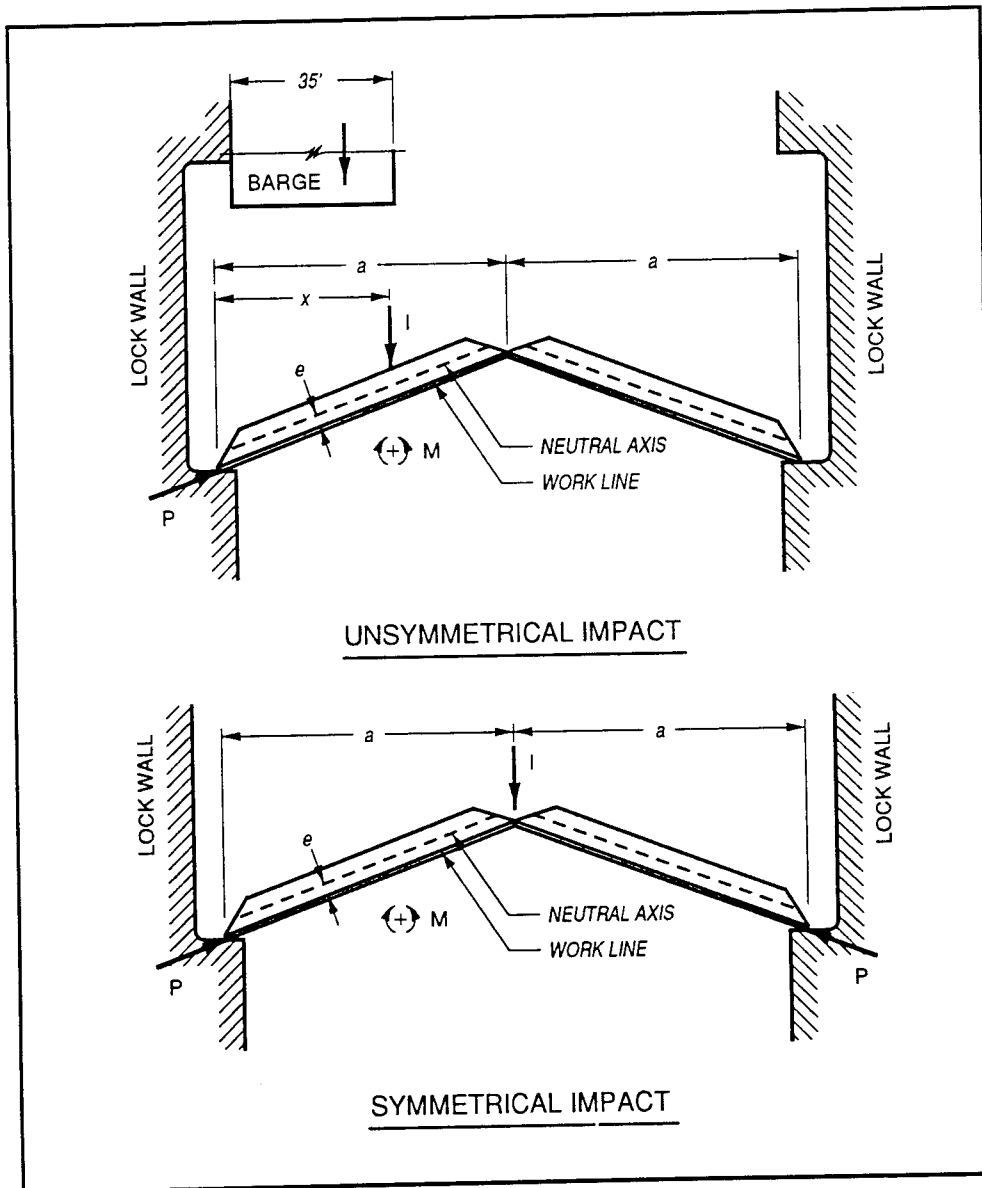

Figure 6. Impact loads for miter gate girders

The equations used to find the axial and flexure loads are

a. Symmetrical impact:

$$P = \frac{5I}{\sqrt{10}} \quad (1)$$

$$M = -Pe \quad (2)$$

b. Unsymmetrical impact:

$$P = \frac{(4x + a)I}{\sqrt{10} a} \quad (3)$$

$$M = \left[\frac{Ix(a - x)}{a} \right] - Pe \quad (4)$$

where:

P = axial loads

I = impact load specified as 400 kips for symmetrical impact and 250 kips for unsymmetrical impact

M = flexure load

e = distance between work line and neutral axis of the girder

x = distance between the quoin contact point and the unsymmetrical impact load position

a = distance between quoin contact point and miter contact

Earthquake loads

Design loads are specified based on an operational basis earthquake (OBE) having a 50 percent chance of being exceeded in 100 years. This translates to a probability of annual exceedance of 0.0069, or approximately 145 years mean recurrence interval. The earthquake load is based on inertial hydrodynamic effects of water moving with the structure. This is determined based on Westergaard's equation:

$$p = \frac{7}{8} \gamma_w a_c \sqrt{Hy} \quad (5)$$

where

p = lateral pressure at a distance y below the pool surface

γ_w = unit weight of water (62.428 lb/ft³)

H = pool depth

a_c = maximum acceleration of the supporting lock wall due to the OBE (expressed as a fraction of gravitational acceleration g)

The lock wall is assumed to be rigid in determination of a_c , and the assumed direction of a_c is parallel to the lock center line. The inertial forces resulting from the mass due to structural weight, ice, and mud are not included in the earthquake loads because the magnitudes of these loads are insignificant compared to the hydrodynamic loads obtained from Westergaard's equation.

Load combinations

EM 1110-2-2105 specifies that miter gates shall have design strengths at all sections at least equal to the required strengths calculated for the factored loads and forces in the following load combinations:

$$1.4H_s + 1.0I \quad (6)$$

$$1.4H_s + 1.0H_t \quad (7)$$

$$1.2D + 1.6(C + M) + 1.0H_t \quad (8)$$

$$1.2D + 1.6(C + M) + 1.2Q \quad (9)$$

$$1.2H_t + 1.0E \quad (10)$$

where

D = dead loads

Q = maximum operating load

E = earthquake load

I = barge impact loads

C = ice load

M = mud load

H_s = hydrostatic loads

H_t = temporal hydraulic load

Load cases

As specified in EM 1110-2-2703, the following load cases shall be considered with the appropriate loading combinations:

a. *Case 1: Mitered condition.* Loads include hydrostatic loads due to upper and lower pools and barge impact or temporal hydraulic loads (Equations 6 and 7). Although not included in Equations 6 and 7, loads C , D , and M act when the gate is in the mitered position. However, in the mitered position the effects of C , D , and M will not control the member sizes. Loads C , D , and M are accounted for in load Case 2 in which they may be controlling. Lateral ice loads are not considered in Equations 6 and 7 (EM 1110-2-2105). It would be appropriate to include such a load for I as specified by Equation 6. However, design for a lateral ice load of 5 kips/ft (as specified in EM 1110-2-2105) with a load factor of 1.0 will not control the design when compared to the design required by the impact loads.

- (1) Above pool. Equation 6 is applicable to the girders located above the pool (upper pool elevation for the upper gate and lower pool elevation for the lower gate) where barge impact may occur. The skin plate and intercostals need not be designed for barge impact. For design of skin plate and intercostals located above the pool, a minimum hydrostatic head of 6 ft is assumed.
- (2) Below pool. The upper gate is designed assuming that the lock is dewatered. Loads include hydrostatic loads due to upper pool only (Equation 7, $H_t = 0$). The lower gate is designed considering normal upper and lower pool elevations including temporal hydraulic load H_t . H_t is applicable only to the submerged part of the gate.

b. *Case 2: Gate torsion.* Loads include gravity loads (C , M , and D) and operating equipment load Q or temporal hydraulic load H_t (Equations 8 and 9). In this condition there are no differential hydrostatic loads.

- (1) Temporal condition. Equation 8 is applied to consider gate leaf torsion with the temporal hydraulic load acting on the submerged part of leaf (the temporal hydraulic load may act in either direction).

- (2) Submerged obstruction. Equation 9 is applied to consider leaf torsion that may be caused by a submerged obstruction. For this case, it is assumed that the bottom of the leaf is held stationary by a submerged obstruction while Q is applied causing the gate leaf to twist.
- c. *Case 3: Earthquake.* Equation 10 is applied if the gate is mitered and hydrostatic loads are acting due to upper and lower pools. The earthquake acceleration is to be applied in the direction parallel to the lock center line. Elastic structural analysis should be performed with no allowance for ductility.

Analysis Procedure

The structural design specifications and analysis assumptions used in CMITER-LRFD are according to EM 1110-2-2703, EM 1110-2-2105, AISC (1986), and Elingwood (1993).

Procedures used to analyze and investigate the major structural elements of a horizontally framed miter gate are as discussed below:

Skin plate

The skin plate is analyzed as a rectangular flat plate with all edges fixed. A uniform load equal to the water pressure at the center of the panel under consideration is assumed to act over the entire surface.

The skin plate is to be sized using:

- a. Yield stress criteria, where the maximum calculated stress should be less than the yield limit state of

$$\alpha \phi_b F_y$$

where

α = a reliability factor for HSS and has a value of 0.9 as defined earlier

ϕ_b = bending resistance factor equal to 0.9 as defined earlier

F_y = yield stress

- b. Deflection criteria, where the maximum deflection allowable is $0.4t$ where t = the skin plate thickness.

- c. Fatigue criteria, where the maximum calculated stress range shall be less than the fatigue limit F_r (AISC 1986).

Stress and deflection are calculated using the following equations (EM 1110-2-2703, AISC 1989, and Timoshenko 1959):

$$F_N = \frac{0.5 W b^2}{t^2 \left[1 + 0.623 \left(\frac{b}{a} \right)^6 \right]} \quad (11)$$

$$\delta = \frac{0.0284 W b^4}{\left[1 + 1.056 \left(\frac{b}{a} \right)^5 \right] E t^3} \quad (12)$$

where

F_N = nominal stress ($\leq \alpha \phi_b F_y$ for yield stress criteria and $F_N \leq F_r$ for fatigue criteria)

W = factored uniform load W_u for yield stress criteria and unfactored uniform hydrostatic loads W for fatigue criteria

t = plate thickness

a = larger plate dimension

b = smaller plate dimension

δ = deflection ($\delta < \delta_{max} = 0.4t$)

E = modulus of elasticity

The minimum size of the skin plate above the pool level should be determined using an assumed hydrostatic head of 6.0 ft (Figure 5).

Intercostals

Intercostals will be flat plates or T-sections, sized in such a manner that the maximum calculated moment is less than the nominal bending strength $\alpha \phi_b M_n$. Intercostals are configured as vertical fixed-end beams with supports at the center line of girder webs. According to EM 1110-2-2703, the intercostals may be designed as simple or fixed-end beams. An effective width of the skin plate is assumed to act with the intercostal plate or T-section, producing a T-section when interacting with a plate and an I-section when interacting with a T-section. The effective width of the skin plate on each side of the plate or T-section is calculated using the

width-to-thickness ratio of $\frac{95}{\sqrt{F_y}}$. Figure 7 shows the geometry of both sections.

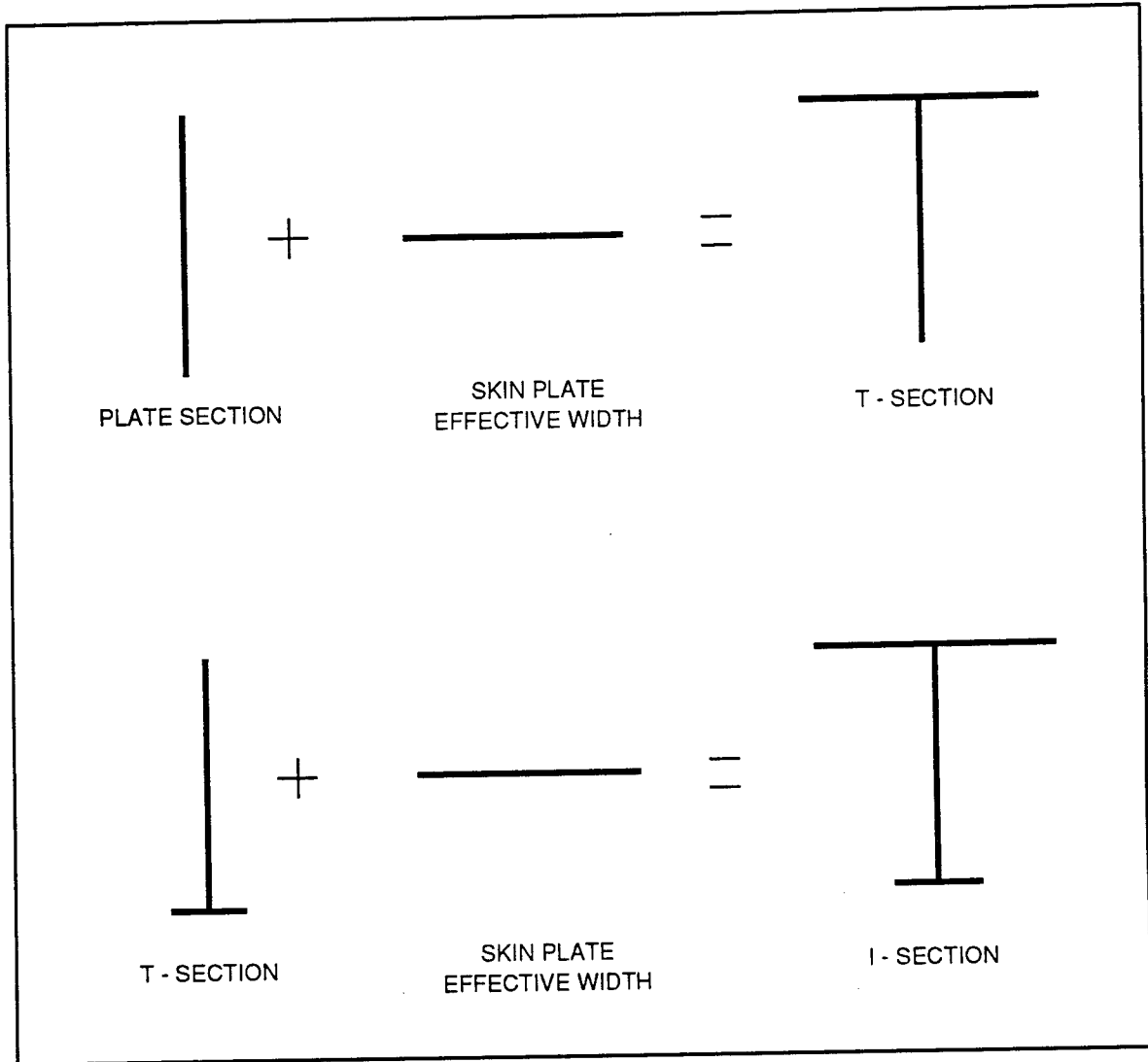

Figure 7. Intercostal sections

Assuming average water pressure, the loading begins at the edge of the girder flange or a maximum of 6 in. from the center line of the girder web. The assumed loading is applied over an area with the boundary lines being 45 deg from the point at the edge of the flange (or 6 in.), and half the distance between intercostals. These boundary lines intersect with the load line boundaries from adjacent panels at a point midway between intercostals, thereby forming an effective load area of two triangular areas, one at each end, usually with a rectangular section in the center (Figure 8). Figure 8 also shows the equations used to calculate the fixed-end moment (FEM), and the simple supported-beam moment (SBM) at the center line of the intercostals for trapezoidal and triangular loading.

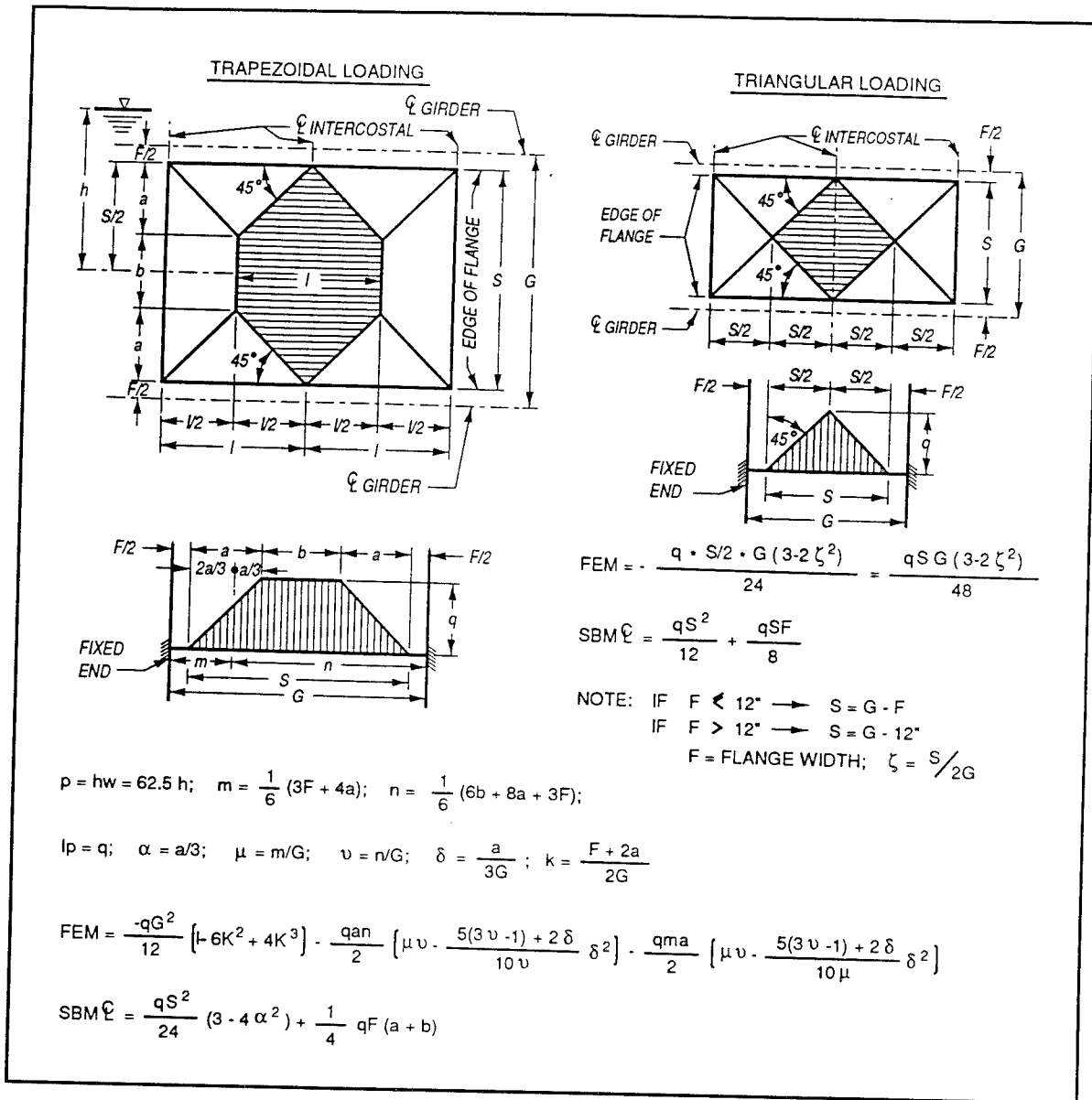

Figure 8. Intercostal loading diagram

The bending strength of the intercostals is the plastic moment for a simply supported beam since the compression flange is supported continuously by the skin plate. For fixed and pin ends, the bending strength can be found by use of the equations presented below:

- a. For T-beams loaded in the plane of symmetry and bending about the major axis, with flange and web slenderness ratios less than the corresponding values of λ_r in Table B5.1 of AISC (1986):

$$M_n = M_{cr} = \frac{C_b \pi \sqrt{EI_y GJ}}{L_b} \left(B + \sqrt{1 + B^2} \right) \leq M_y \quad (13)$$

where

$$B = \pm 2.3 \left(\frac{d}{L_b} \right) \sqrt{\frac{I_y}{J}} \quad (14)$$

and

M_n = nominal flexure strength

M_{cr} = critical flexure strength

C_b = bending coefficient dependent upon moment gradient. A unit value is used for intercostal design to represent the most severe loading case.

E = modulus of elasticity of steel (29,000 ksi)

I_y = moment of inertia about y-axis, in.⁴

G = shear modulus of elasticity of steel, ksi

J = torsional constant, in.⁴

L_b = laterally unbraced length

M_y = initial yield bending moment, kip-in.

d = stem height

The plus sign for B applies when the stem is in tension, and the minus sign applies when the stem is in compression.

- b. For doubly and singly symmetrical I-shaped beams bending about the major axis, the nominal flexure strength M_n is the lowest value obtained according to the limit state of lateral torsional buckling, flange local buckling, and web local buckling.

The nominal flexural strength shall be calculated using the criteria discussed later in this chapter.

Horizontal girders

Horizontal girders are, in effect, a series of three hinged arches that transmit the water pressures to the lock walls through the quoin blocks. Because horizontal girders are subject to combined bending and axial loads, they should be designed through use of the beam-column criteria.

The following is a list of criteria and assumptions that are used in the design of horizontal girders:

- a. *Girder analysis.* The basic procedure for girder analysis is to assume that each girder is isolated as an individual member. Each member is designed as beam-column elements using the criteria discussed in this chapter (AISC 1986, Elingwood 1993).
- b. *Axial, flexure, and shear strengths.* Axial, flexure, and shear strengths are calculated using the criteria discussed in this chapter (AISC 1986, Elingwood 1993) with the following assumptions:
- (1) Upstream girder flanges are braced continuously by the skin plate. Downstream flanges are braced by vertical diaphragms to resist lateral displacement and twist of the cross section.
 - (2) The length of girders considering buckling about the major axis (in the plane of the web) is the distance between the quoin block and miter block l_x . The ends are assumed pinned with $K = 1.0$.
 - (3) The length of girders considering buckling about the minor axis is the distance between intermediate diaphragms l_y . The ends are assumed fixed with $K = 0.65$.
 - (4) The design strength of compression members whose elements have width-to-thickness ratios less than λ_r of Table 1 is $\alpha\phi_c P_n$ (AISC 1986)

Table 1 Width-to-Thickness Ratios			
Member	Compact Section	Noncompact Section	Slender Section
Flanges	$\frac{b}{t} \leq \frac{65}{\sqrt{F_y}}$	$\frac{b}{t} \leq \frac{106}{\sqrt{F_{yw} - 16.5}}$	$\frac{b}{t} > \frac{106}{\sqrt{F_{yw} - 16.5}}$
Web	$\frac{h_c}{t_w} \leq \frac{253}{\sqrt{F_y}}$	Not applicable	$\frac{h_c}{t_w} > \frac{253}{\sqrt{F_y}}$
Skin plate	$\frac{b}{t} \leq \frac{65}{\sqrt{F_y}}$	$\frac{b}{t} \leq \frac{106}{\sqrt{F_{yw} - 16.5}}$	$\frac{b}{t} > \frac{106}{\sqrt{F_{yw} - 16.5}}$

$$\phi_c = 0.85$$

$$P_n = A_g F_{cr}$$

$$\text{For } \lambda_c \leq 1.5$$

$$F_{cr} = (0.658\lambda_c^2) F_y \quad (15)$$

For $\lambda_c > 1.5$

$$F_{cr} = \left[\frac{0.877}{\lambda_c^2} \right] F_y \quad (16)$$

where

ϕ_c = compression resistance factor

P_n = nominal actual strength, kips

A_g = gross area of member, sq in.

F_{cr} = critical actual stress, ksi

F_y = specified yield stress, ksi

$$\lambda_c = \frac{Kl}{r\pi} \sqrt{\frac{F_y}{E}} \quad (17)$$

where

K = effective length factor

l = unbraced length of member, in.

r = governing radius of gyration about plane of buckling, in.

E = modulus of elasticity, ksi

- (5) The nominal flexure strength M_n is the lowest value obtained according to the limit state of lateral torsional buckling (LTB), flange local buckling (FLB), and web local buckling (WLB) (AISC 1986). The flexure design strength is $\alpha\phi_b M_n$, and the nominal flexural strength M_n shall be determined as follows for each limit state (EM 1110-2-2105 and AISC 1986):

For $\lambda \leq \lambda_p$:

$$M_n = M_p \quad (18)$$

For $\lambda_p < \lambda \leq \lambda_r$

(for limit state of lateral torsional buckling):

$$M_n = C_b \left[M_p - (M_p - M_r) \left(\frac{\lambda - \lambda_p}{\lambda_r - \lambda_p} \right) \right] \leq M_p \quad (19)$$

(for limit state of flange and web local buckling):

$$M_n = M_p - (M_p - M_r) \left(\frac{\lambda - \lambda_p}{\lambda_r - \lambda_p} \right) \quad (20)$$

For $\lambda > \lambda_r$:

$$M_n = M_{cr} = SF_{cr} \quad (21)$$

where

$$\lambda = \frac{L_b}{r_y} \text{ for LTB (lateral torsional buckling)} \quad (22)$$

$$\lambda = \frac{b}{t} \text{ for FLB (flange local buckling)} \quad (23)$$

$$\lambda = \frac{h_c}{t_w} \text{ for WLB (web local buckling)} \quad (24)$$

$$\lambda_p = \frac{300}{\sqrt{F_{yf}}} \text{ for LTB} \quad (25)$$

$$\lambda_p = \frac{65}{\sqrt{F_{yf}}} \text{ for FLB} \quad (26)$$

$$\lambda_p = \frac{640}{\sqrt{F_{yf}}} \text{ for WLB} \quad (27)$$

$$\lambda_r = \frac{X_1}{(F_{yw} - F_r)} \sqrt{1 + \sqrt{1 + X_2 (F_{yw} - F_r)^2}} \text{ for LTB} \quad (28)$$

$$X_1 = \frac{\pi}{S_x} \sqrt{\frac{EGJA}{2}} \quad (29)$$

$$X_2 = 4 \frac{C_w}{I_y} \left(\frac{S_x}{GJ} \right)^2 \quad (30)$$

$$\lambda_r = \frac{106}{\sqrt{F_{yw} - 16.5}} \text{ for FLB} \quad (31)$$

$$M_r = (F_{yw} - F_r) S_{xc} \leq F_{yf} S_{xt} \text{ for LTB} \quad (32)$$

$$M_r = (F_{yw} - F_r) S_{xc} \text{ for FLB} \quad (33)$$

$$M_r = R_e F_{yf} S_x \text{ for WLB} \quad (34)$$

$$R_e = 1.0 - 0.1(1.3 + a_r)(0.81 - m) \leq 1.0 \quad (35)$$

$$F_{cr} = \frac{C_b X_1 \sqrt{2}}{S_{xc} \lambda} \sqrt{1 + \frac{X_1^2 X_2}{2\lambda^2}} \text{ for LTB} \quad (36)$$

$$F_{cr} = \frac{11,200}{\lambda^2} \text{ for FLB} \quad (37)$$

The terms used in the above equations are:

λ = controlling slenderness parameters

λ_p = largest value of λ for which $M_n = M_p$

M_n = nominal flexural strength, kip-in.

M_p = plastic moment, kip-in.

M_r = limiting buckling moment, kip-in.

λ_r = largest value of λ for which buckling is inelastic

C_b = bending coefficient dependent upon moment gradient. (A unit value is used for girders designed to represent the most severe loading case.)

M_{cr} = buckling moment, kip-in.

S = section modulus, in.³

F_{cr} = critical stress, ksi

L_b = laterally unbraced length, in.

r_y = radius of gyration about minor axis, in.

b = flange width, in.

t = flange thickness

h_c = twice the distance from the neutral axis to the inside face of the compression flange less the fillet or corner radius, in.

t_w = web thickness, in.

F_{yf} = yield strength of the flange, ksi

$X_{1,2}$ = beam buckling factor

F_{yw} = yield strength of the web, ksi

F_r = compressive residual stress in flange = 16.5 ksi

S_x = section modulus

E = modulus of elasticity, ksi

G = shear modulus of elasticity of steel, ksi

J = torsional constant, in.⁴

A = cross-section area, in.²

C_w = warping constant, in.⁶

I_y = moment of inertia, minor axis, in.⁴

S_{xc} = section modulus of the outside fiber of the compression flange, in.³

S_{xt} = section modulus of the outside fiber of the tension flange, in.³

R_e = hybrid girder factor

a_r = ratio of web area to compression flange area

m = ratio of web yield stress to flange yield stress or the critical stress

- (6) The interaction of flexure and compression in symmetrical shapes shall be limited by the following formulas (AISC 1986):

$$\text{For } \frac{P_u}{\alpha\phi_c P_n} \geq 0.2$$

$$\frac{P_u}{\alpha\phi_c P_n} + \frac{8}{9} \left(\frac{M_{ux}}{\alpha\phi_b M_{nx}} + \frac{M_{uy}}{\alpha\phi_b M_{ny}} \right) \leq 1.0 \quad (38)$$

$$\text{For } \frac{P_u}{\alpha\phi_c P_n} < 0.2$$

$$\frac{P_u}{2\alpha\phi_c P_n} + \left(\frac{M_{ux}}{\alpha\phi_b M_{nx}} + \frac{M_{uy}}{\alpha\phi_b M_{ny}} \right) \leq 1.0 \quad (39)$$

where

P_u = required compressive strength, kips

α = reliability factor for HSS

ϕ_c = resistance factor for compression, $\phi_c = 0.85$

P_n = nominal compressive strength, kips

M_u = required flexural strength, kip-in.

$$M_u = B_1 M_{nt}$$

M_{nt} = required flexural strength in member, assuming there is no lateral translation of the frame, kip-in.

M_n = nominal flexural strength, kip-in.

ϕ_b = resistance factor for flexure $\phi_b = 0.90$

$$B_1 = \frac{C_m}{\left(1 - \frac{P_u}{P_e}\right)} \geq 1 \quad (40)$$

$$P_e = \frac{A_g F_y}{\lambda_c^2} \quad (41)$$

where

$$C_m = 1.0$$

A_g = gross area of member, in.²

λ_c = as defined in section to calculate axial strength of compression members

(7) The design shear strength for webs is

$$\alpha \phi_v V_n$$

where

$$\alpha = 0.9$$

$$\phi_v = 0.9$$

and the nominal shear strength V_n is determined as follows (AISC 1986):

$$\text{For } \frac{h}{t_w} \leq 187 \sqrt{\frac{K}{F_{yw}}}$$

$$V_n = 0.6 F_{yw} A_w \quad (42)$$

$$\text{For } 187 \sqrt{\frac{K}{F_{yw}}} < \frac{h}{t_w} \leq 234 \sqrt{\frac{K}{F_{yw}}}$$

$$V_n = 0.6F_{yw}A_w \frac{187 \sqrt{\frac{K}{F_{yw}}}}{\frac{h}{t_w}} \quad (43)$$

$$\text{For } \frac{h}{t_w} > 234 \sqrt{\frac{K}{F_{yw}}}$$

$$V_n = A_w \frac{26,400K}{\left(\frac{h}{t_w}\right)^2} \quad (44)$$

The web plate buckling coefficient K is given by

$$K = 5 + \frac{5}{\left(\frac{a}{h}\right)^2} \quad (45)$$

except that K shall be taken as 5 if a/h exceeds 3 or $[260/(h/t_w)]^2$. When stiffeners are not required, $K = 5$. In unstiffened girders, h/t shall not exceed 260

where

h = clear distance between flanges, in.

t_w = web thickness, in.

F_{yw} = yield strength of the web, ksi

A_w = cross-section area of the web, in.²

a = clear distance between transverse stiffeners

c. *Axial, flexure, and reaction loads.* Equations to find the axial, flexure, and reaction loads are (see Figure 9 for details):

$$P1 = \frac{WL}{2} \cot \theta \quad (46)$$

$$P2 = Wt \quad (47)$$

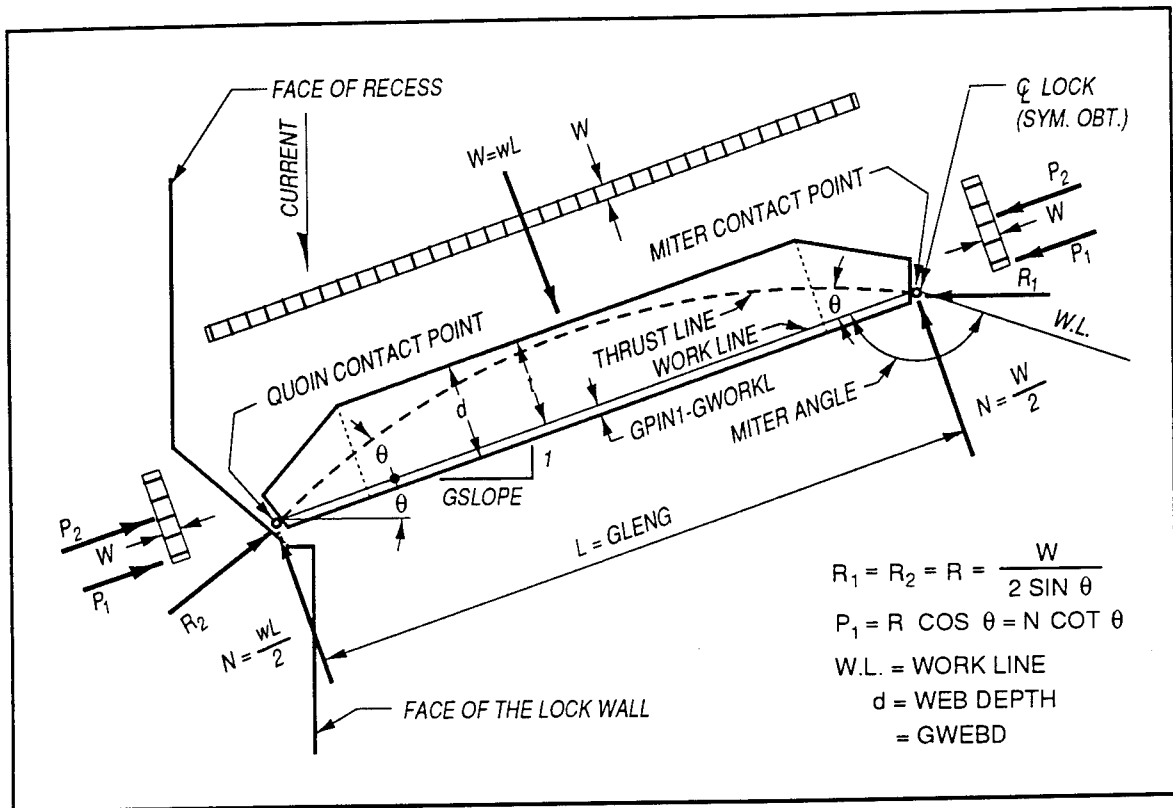

Figure 9. Girder reactions

$$P = P_1 + P_2 \quad (48)$$

$$M_x = \frac{W}{2} [Lx - La \cot \theta + (t - a)^2 - a^2 - x^2] \quad (49)$$

$$N = \frac{WL}{2} \quad (50)$$

where

P_1 = axial loads due to the reaction at the lock wall

W = uniform loads

L = girder length

θ = miter angle

P_2 = axial loads due to the uniform load

t = distance between work line and the outside face of the upstream flanges

P = maximum resultant compression load

M_x = flexure load at distance x from the miter contact point

x = distance where flexural strength is calculated

a = distance between the work line and the neutral axis

N = girder reaction perpendicular to the girder axial axis
(maximum shear load)

- d. *Flange width and thickness.* The minimum flange widths are to be 8 in. for upstream flanges and 12 in. for downstream flanges. The minimum thickness is specified as 3/8 in. for webs and 1/2 in. for flanges (EM 1110-2-2703). The downstream flanges are limited to 24 in. or $24t_f$ (t_f is the flange thickness), reducing the possibility of the flange being undesirably wide and thin. The maximum change in flange width on the same edge of a girder web is 6 in., with a 3-in. differential on each edge of the flange except for the downstream flange of the bottom girder, where the total 6 in. of differential may be on the upper edge of the flange (Figure 10). This applies between the sections at the center line of a girder, where the upstream flange is maximum width and the downstream flange is minimum width. This also applies at a section at the end of the girder where the upstream flange is a minimum width and the downstream flange is a maximum width. The bottom girder is a special case in which the downstream flange is a maximum of 15 in. and a minimum of 9 in., with an extension below the center line of the web of 3 in. to provide additional clearance between the bottom girder and the sill. For the end section of the bottom girder, where the downstream flange is heavier, the upper portion of the flange is a maximum of $15t_f$ above the center line of the girder web.
- e. *Upstream flange.* The upstream flange of the bottom girder should extend 6 in. below the center line of the girder web, from end to end of the girder, with the skin plate 1/2 in. above the lower edge of the flange. A minimum of 4 in. should be used above the center line of the web, thus making a minimum width of 10 in. for the upstream flange of the lower girder.
- f. *Skin plate extension.* The maximum extension of the skin plate above the center line of the top girder web is 8 in., to prevent interference with the operating strut. The maximum extension of the skin plate above the top flange is 1/2 in., limiting the maximum width of the upstream flange of the top girder to 15 in.
- g. *Skin plate width.* An effective portion of the skin plate is assumed to act with the upstream flange. The effective width of the skin plate next to each edge of the upstream girder flange is based on a

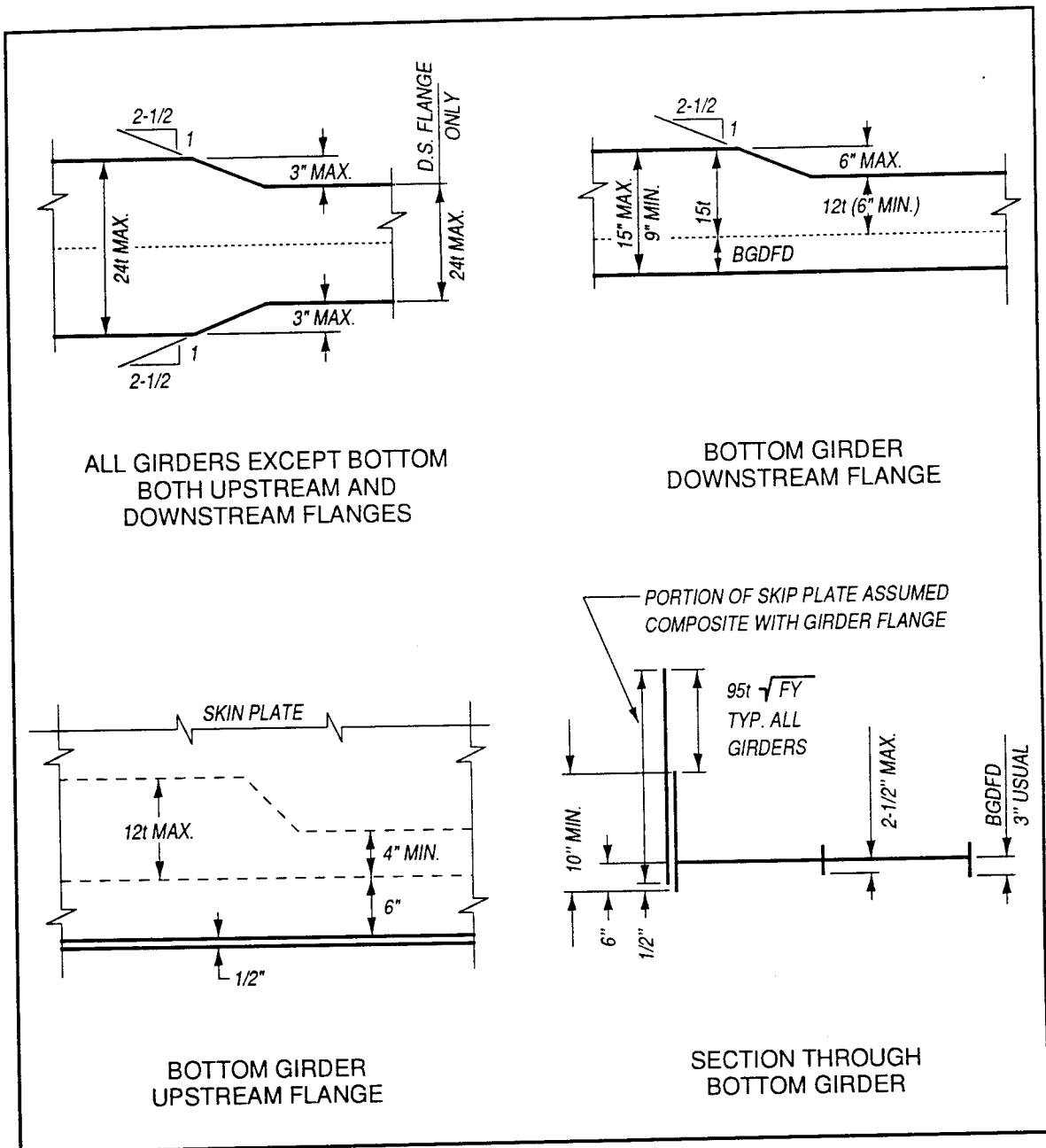

Figure 10. Girder flange data

width-to-thickness ratio consistent with design assumptions (assumption of compact or noncompact section).

- h. *Webs.* Webs are designed using requirements for uniformly compressed stiffened elements. The use of slenderness parameters for webs in combined flexure and axial compression in Table B5-1 of AISC (1986) should be avoided since these criteria were developed for rolled shape beam columns and may not apply for deep girder sections.

i. *Ratio values.* The ratio values for compact, noncompact, and slender sections are shown in Table 1.

Tapered end section

The tapered end sections of girders are analyzed in a manner different from that used to analyze girder sections with full web depths. The moment is determined assuming a cantilever section of length Z' with a uniform water load plus the moment created by the girder reaction being eccentric from the centroid of the section (Figure 11).

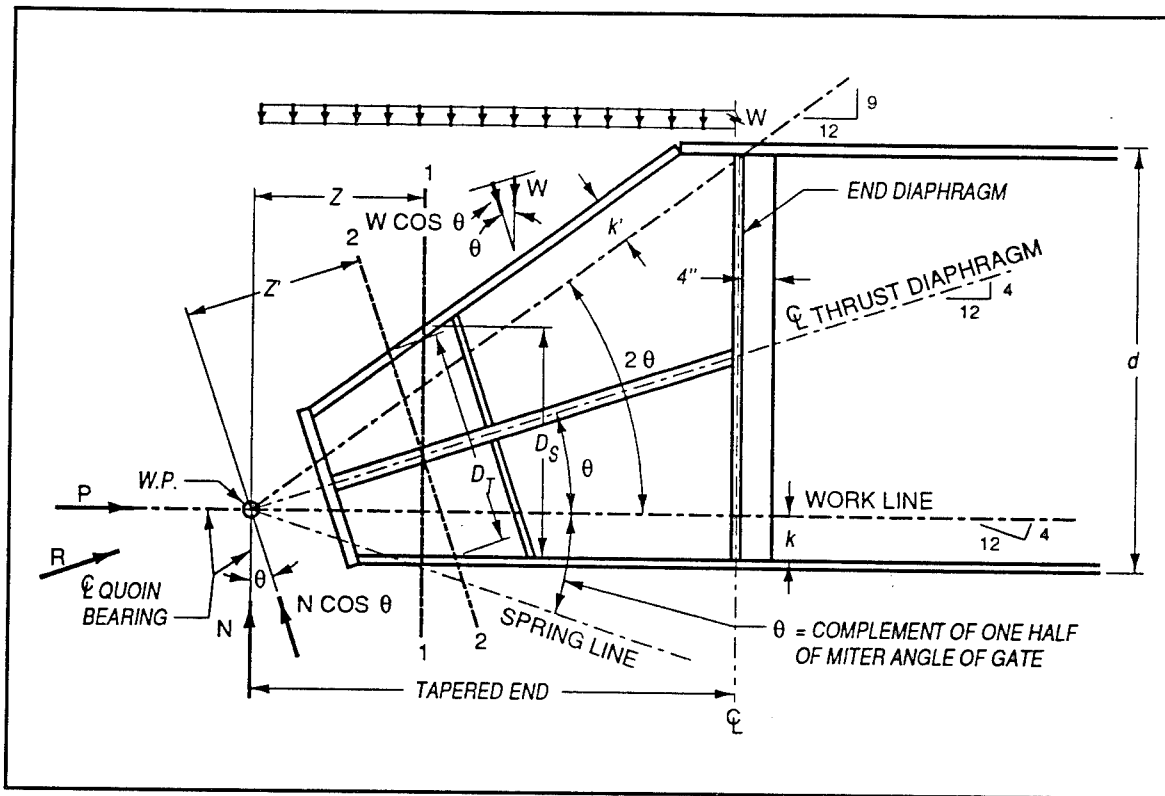
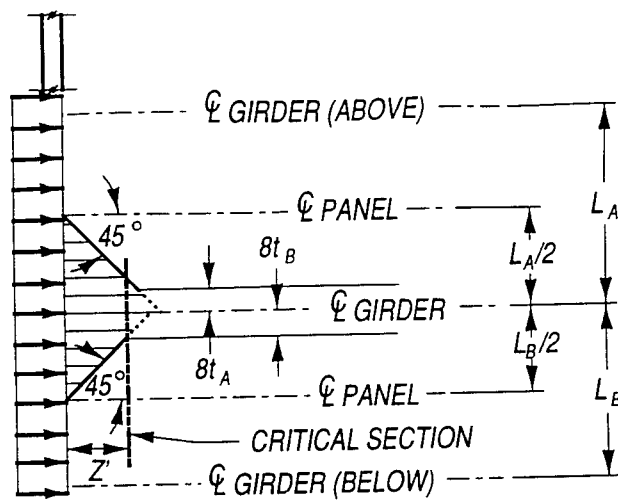
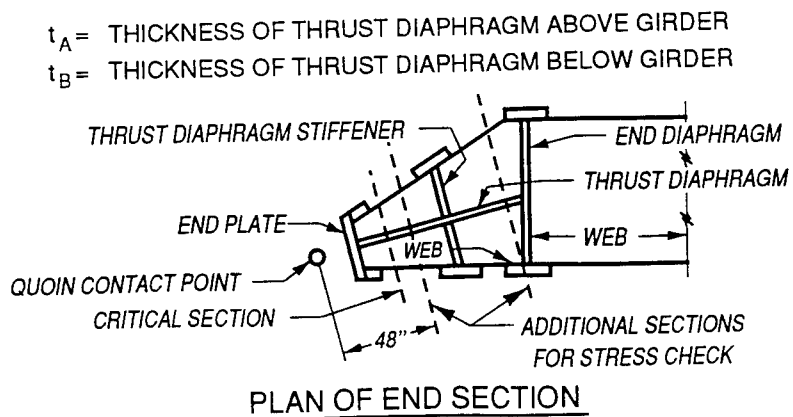

Figure 11. Tapered end critical section

The critical point is at a distance Z' from the end of the web. Z' is equal to one half the smaller span between adjacent girders (above and below) to the web under consideration, minus eight times the thrust diaphragm thickness. If eight times the thrust diaphragm thickness is greater than one half the smaller adjacent span, the value of Z' becomes negative, and the minimum section for the tapered web is taken as the web width at the end of the web, with one half the height of the trust diaphragm and the appropriate upstream and downstream girder flanges. The maximum width of flanges shall be $24t_f$, reducing the possibility of the flange being undesirably wide and thin. Figures 11 and 12 show the distribution of the loads in the tapered section and the locations for which the stresses are calculated.



VERTICAL LONGITUDINAL SECTION LOOKING AT THRUST DIAMETER

$$Z'_A = L_A/2 - 8t_A \quad Z'_B = L_B/2 - 8t_B$$

Z'_A AND Z'_B MUST BE POSITIVE

$$Z' = \text{IF } 8t \text{ IS GREATER THAN } \frac{L_A}{2} \text{ OR } \frac{L_B}{2}$$

$$\text{FOR } L_A = L_B = L \text{ AND } t_A = t_B = t$$

$$Z' = L/2 - 8t$$

$$Z = Z' \cos \Theta$$

Figure 12. Tapered end load distribution

End diaphragm

End diaphragms, often called quoin and miter diaphragms, are designed as a panel acting as a skin plate, with the effective panel being between the stiffener angle and the next lower girder. The stiffener is at the midpoint between the girders. Design loads are the hydrostatic head at the center of the effective panel and the reactions produced by the diagonal prestress loads. Each end diaphragm, between girders, is divided into four panels subjected to the water pressure. Four panels are surrounded by the girder webs, vertical flange at the skin plate, the thrust diaphragm, and the horizontal end diaphragm stiffener. The panels are assumed fixed on all four edges and designed by the same formulas as applied to the skin plate. The end diaphragm stiffeners are assumed fixed at the upstream end and at the center line of the thrust diaphragm. The diaphragm load is triangular on the ends, with the boundary lines at 45 deg from the vertical at the point of the triangle, this point being the center line of the thrust diaphragm and the upstream ends of the stiffener (Figure 13). A part of the end diaphragm shall be assumed effective with the stiffener, with the effective width equal to $\frac{95}{\sqrt{F_y}}$ on each side of the angle.

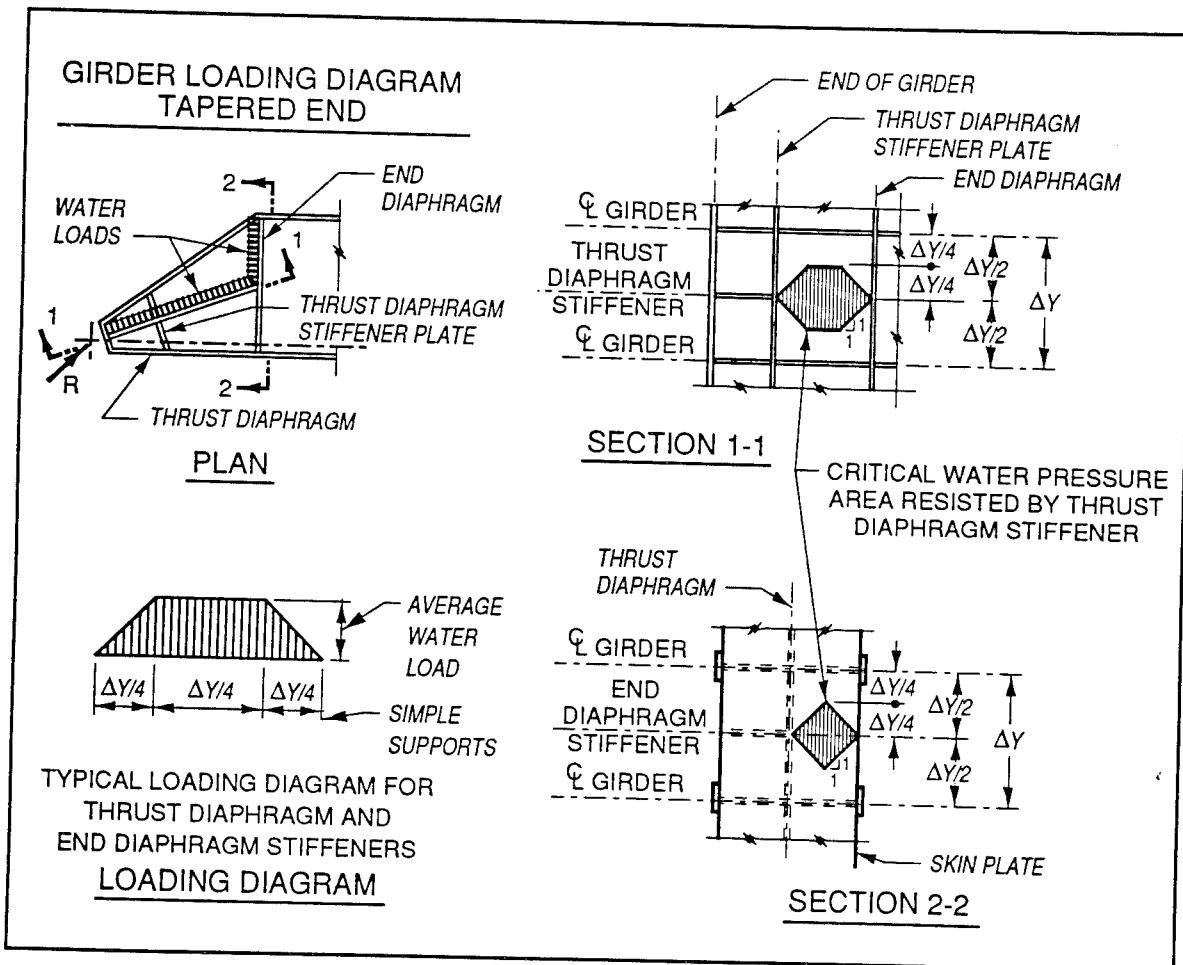

Figure 13. Diaphragm loads

Thrust diaphragm

The thrust diaphragm is tangent to the thrust curve of the gate at the contact points and is approximately in line with the thrust curve between the contact points and the end diaphragm, which is the limit of the thrust diaphragm. The thrust diaphragms will distribute the reactions of the girder web into the quoin block and also serve as a damming surface between the end plate and the end diaphragm. Part of the thrust diaphragm is also considered effective in the quoin post, making it subject to bearing, skin plate, and column action stresses. Shear stress is to be checked also, but is not combined with the listed forces. The analysis is based on combined axial load from the girder reaction and bending from water damming pressure (Figure 13), which has to be less than or equal to the lesser value of the yield stress or the elastic-limit stress. The flexure stress produced by the damming water pressure can be determined using the skin plate equations (Equation 12), and the axial load is determined as follows (Figure 14):

a. Determine actual load V_a .

$$\theta = \text{zeta}$$

$$V_a = W_u L \cos \theta \quad (51)$$

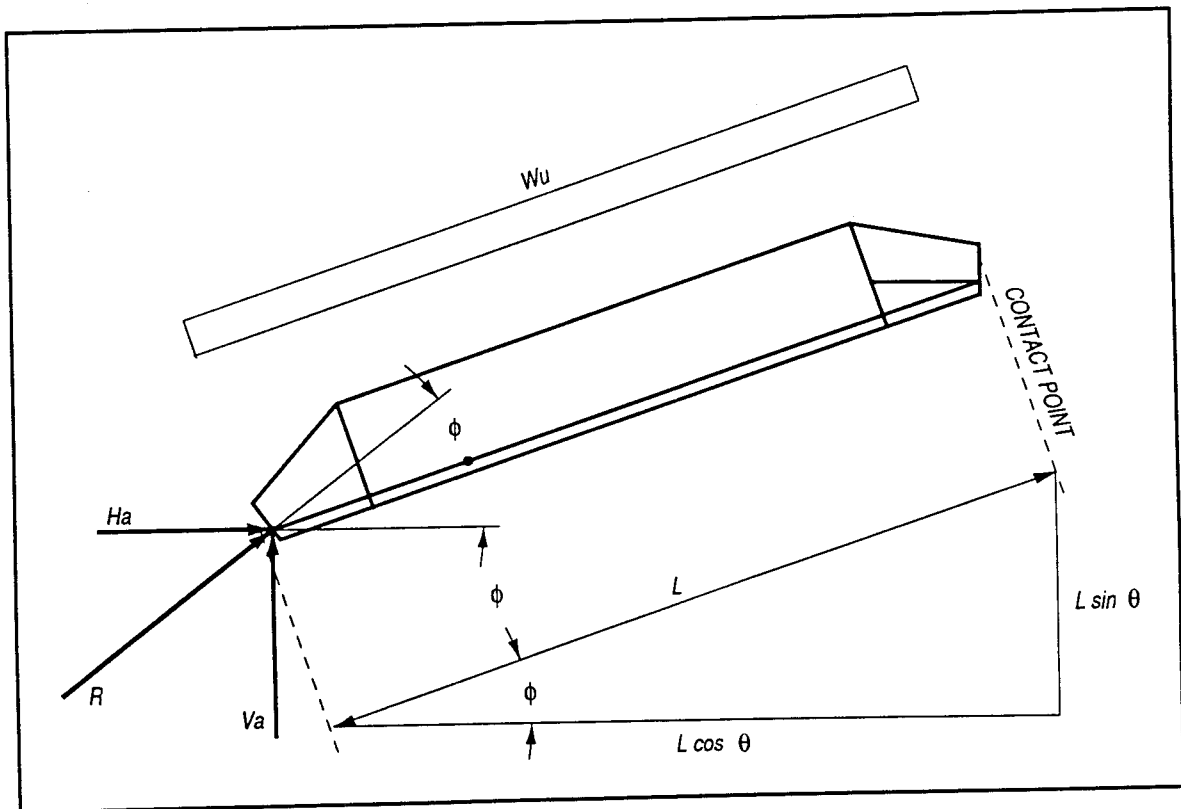

Figure 14. Thrust diaphragm, axial load calculation

- b. Determine H_a using summation of moments in contact point equal $(\Sigma M_{cp} = 0)$.

$$H_a = \frac{V_a L \cos \theta - \frac{W_u L^2}{2}}{L \cos \theta} \quad (52)$$

- c. Determine axial load R

$$R = V_a \sin 2\theta + H_a \cos 2\theta \quad (53)$$

The elastic limit can be found by assuming that the panel under consideration is clamped on all edges and that equal uniform compression exists on two opposite edges, with the critical stress equal to

$$K \frac{E}{1 - \mu^2} \left(\frac{t_d}{b} \right)^2 \quad (54)$$

where

$$K = 7.7 \text{ when } a/b = 1.0$$

$$K = 6.7 \text{ when } a/b = 2.0$$

$$K = 6.4 \text{ when } a/b = 3.0$$

a = longer dimension of panel

b = shorter dimension of panel

μ = Poisson's ratio

t_d = thrust diaphragm thickness

Quoin post

A section of the thrust diaphragms, vertically from top to bottom girders and horizontally from the contact plate to a point $\frac{95}{\sqrt{F_y}}$ beyond the thrust diaphragm stiffener plate, forms a column to support the dead weight of the leaf. The end plate and two vertical stiffeners form one flange of the column. The other flange is formed by a plate perpendicular to the thrust diaphragm, with vertical stiffeners on the outside edges. Figure 15 shows a typical layout of the quoin post.

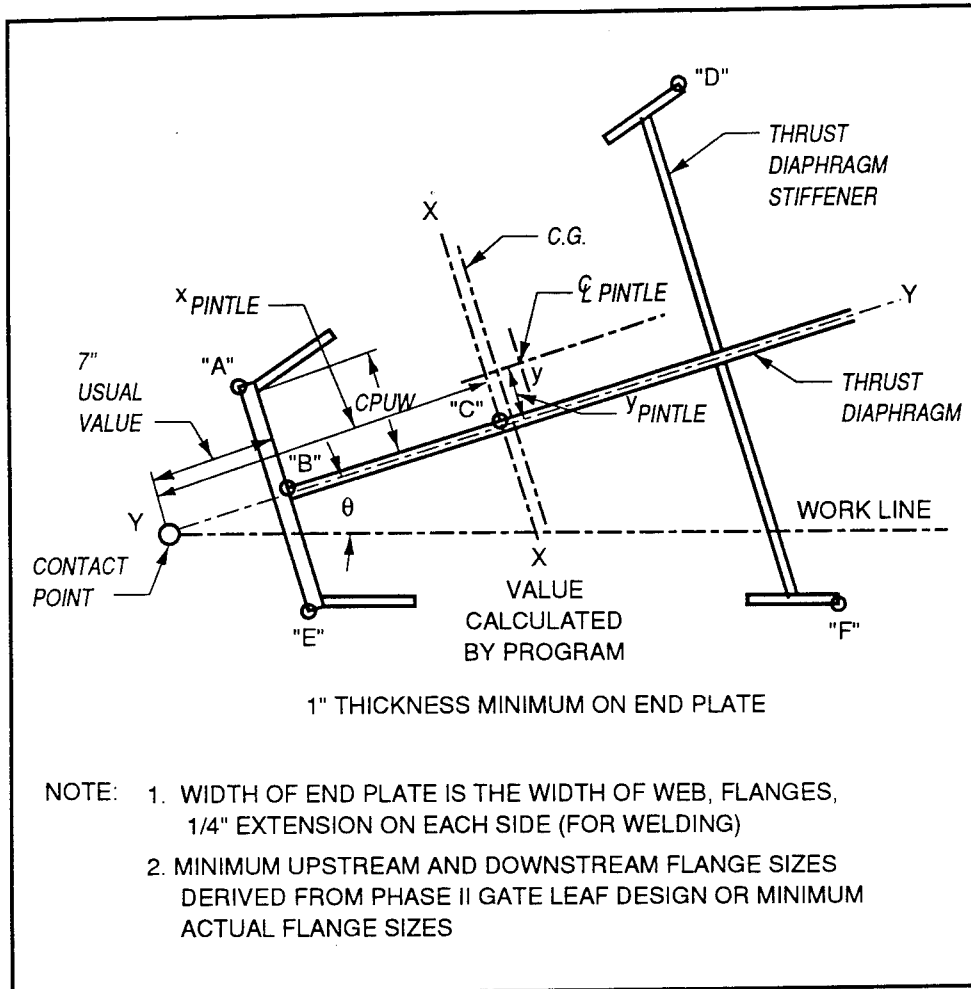

Figure 15. Quoin post layout

The axial load of the quoin post consists of the dead weight of the leaf, plus the ice and mud load. Due to the eccentricity of the pintle and gudgeon pin with respect to the centroid of the quoin post, the quoin post is subjected to axial and bending loads and to the skin plate action of the thrust diaphragm. The following symbols and formulas are used to find the combined loads in the quoin post:

$$M_x = Pe_y \quad (55)$$

$$M_y = Pe_x \quad (56)$$

$$\sigma = \frac{P}{A} + \frac{M_x}{I_x} C_y + \frac{M_y}{I_y} C_x \quad (57)$$

where

P = total axial load (dead weight plus ice and mud)

e_x, e_y = eccentricity distance from centroid of entire quoinpost cross section to (inclined) action line of pintle reaction

C_x and C_y = extreme fiber distance

Diagonals

A gate is a deep cantilever girder with a relatively short span. The skin plate is the web of the girder. If the ordinary formulas for the vertical deflection of a cantilever submitted to shearing and bending stresses are applied, the values obtained will be low. This happens because the skin plate imparts such a great vertical stiffness to the leaf. The stresses in the diagonals are a function of only the torsional (twisting) forces acting upon the leaf. These forces produce a considerable torsional deflection when the gate is being opened or closed.

The shape of the twisted leaf is found geometrically. Then the work done by the loads is equated to the internal work realized by the structure. From this, the resistance offered by each diagonal to twisting of the leaf is calculated as a function of the torsional deflection of the leaf and the dimensions of the structure.

The procedure and equations required to design the diagonal elements are as follows (EM 1110-2-2703):

- a. *Stiffness.* Evaluate the stiffness of the leaf in deforming the diagonal A' . Until more test data are available, it is suggested that A' be taken as the sum of the average cross sectional areas of the two vertical and horizontal girders which bound a panel times $1/8$ for welded horizontally framed leaves with skin of flat plates.
- b. *Elasticity.* Evaluate the elasticity constant of the leaf without diagonals Q_o .

$$Q_o = 4E_s \sum \left(\frac{J}{H} + \frac{J}{v} \right) \quad (58)$$

where

E_s = shearing modulus of elasticity

J = modified polar moment of inertia of the horizontal and vertical members of the leaf

H = distance between top and bottom girder

v = distance from center line of the pintle to extreme miter end of the leaf

c. Location of shear center.

$$X = -\frac{b}{I} \sum a y y_n \quad (59)$$

$$Y = \frac{\sum I_n y}{\sum I_n} \quad (60)$$

where

X, Y = coordinates of shear center

b = distance from the center line of the skin plate to the downstream flange of a horizontal girder

I = moment of inertia of the gate leaf about the vertical axis

a = cross-section area of that part of the horizontal girder that lies outside the midpoint between the skin plate and the downstream flange

y = distance to any horizontal girder from the horizontal centroid axis of a vertical section through the leaf

y_n = distance to any horizontal girder from the horizontal shear center axis of a vertical section through a leaf

I_n = moment of inertia of any horizontal girder about its vertical centroid axis

d. Load torque areas.

e. *Ratio of change.* Calculate the ratio of change in length R_o of diagonal to deflection of leaf when diagonal offers no resistance. R_o is positive for positive diagonals and negative for negative diagonals.

$$R_o = \frac{2wt}{v \sqrt{(w^2 + h^2)}} \quad (61)$$

where

w = width of the panel enclosing diagonals

t = distance from center line of skin plate to center line of diagonal

v = distance from center line of the pintle to extreme miter end of the leaf

h = height of panel enclosing diagonals

f. Required size of diagonals.

$$A = - \frac{\Sigma Tz}{sR_o hv} \quad (62)$$

where

A = cross-section area of diagonal

Tz = torque area (product of the torque T of an applied load and the distance z to the load from the pintle; z is measured horizontally along the leaf. Tz is positive if the load produces a positive deflection).

s = design strength for tension members ($s = \alpha\phi P_n$), which is the lower value of the following:

(1) For yield in the cross section, $\alpha = 0.9$ and $\phi = 0.9$

$$P_n = F_y A_g$$

(2) For fracture in the net section, $\alpha = 0.9$ and $\phi_t = 0.75$

$$P_n = F_u A_e = F_u (U A_g)$$

g. *Ratio.* Evaluate the ratio R of the actual change in length of diagonal to deflection of the leaf. R is positive for positive diagonals and negative for negative diagonals.

$$R = \frac{A'}{A + A'} R_o \quad (63)$$

h. *Elasticity.* Evaluate the elasticity constant of a diagonal Q .

$$Q = \frac{RR_o EA hv}{L} \quad (64)$$

where

E = bending modulus of elasticity

L = length of a diagonal, center to center of pins

i. *Deflection of leaf.* This value is the minimum prestress deflection D_{min}

$$\Delta = \frac{\Sigma Tz}{Q_o + \Sigma Q} \quad (65)$$

- j. *Prestress deflection in diagonals* D_{max} . D is the deflection of the leaf required to reduce the stress in a diagonal to zero. D is always positive for positive diagonals and negative for negative diagonals.

$$D = \frac{sL}{RE} + \Delta \quad (66)$$

- k. *Stresses during normal operation of the gate.* The value of D must be between the minimum and maximum value.

$$s = \frac{RE}{L} (D - \Delta) \quad (67)$$

3 Program CMITER-LRFD General Description

Scope

This chapter presents a general description and the analysis sequence of each module (recommended design, design, and investigation) of the CMITER-LRFD program.

Description

CMITER-LRFD is organized with three distinct functions to design and investigate horizontally framed miter gates (Figure 16). The three functions of the CMITER-LRFD program are separated into three different modules: recommended design module (RECDES), design module (DES), and investigation module (INV). Each module acts as a separate

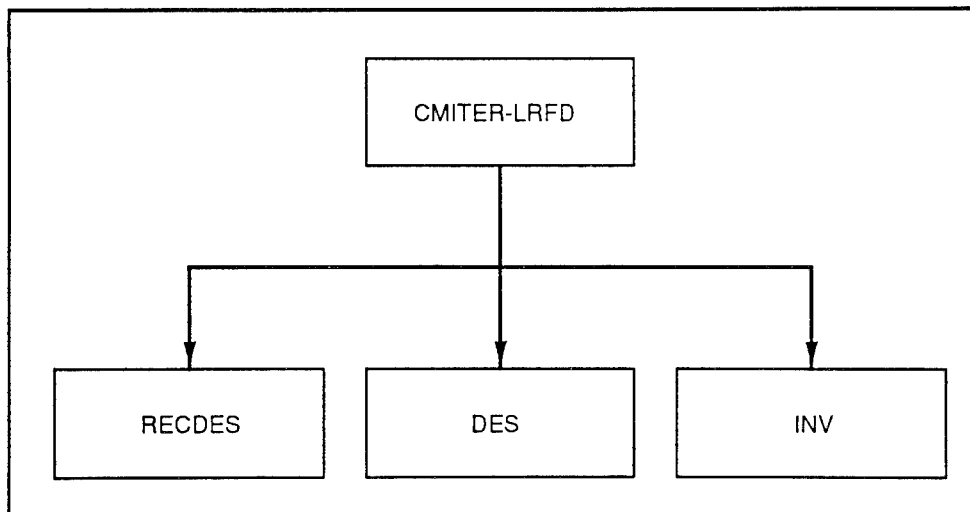

Figure 16. CMITER-LRFD program organization

program and executes one primary task. Each module requires a data file, may be used interactively, and stores results in a file or displays results on a screen.

RECDES

For miter gate design, a trial-and-error process is required to find some basic dimensions that are necessary to start the design. The RECDES module performs calculations that will help to establish meaningful values. However, the selection of the basic dimensions requires the designer's judgment. The dimensions calculated by the RECDES module include a range of girder web depths for minimum weight of each girder, girder spacing for equal load in each girder, and suggested spacing and sizes for intercostals. Dimensions are selected to achieve a minimum weight of the gate for the specified load combination. An advantage gained from using this module is that with a minimum amount of known data, the designer will have a choice of required values to start the design process (Figure 17).

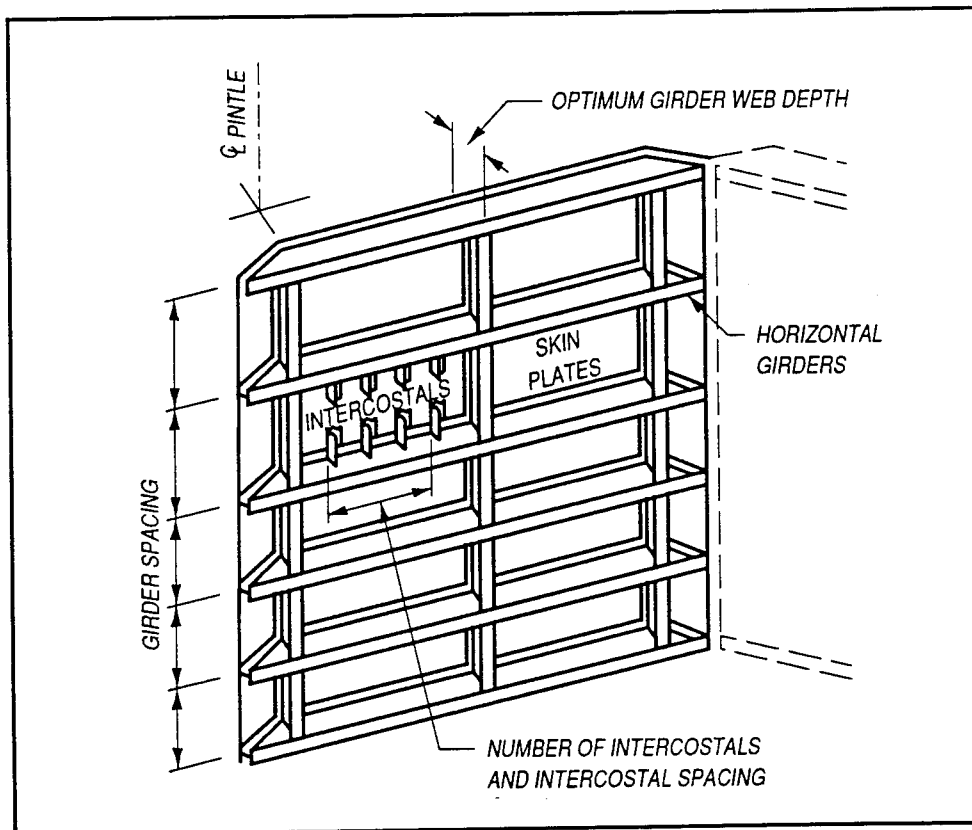

Figure 17. Downstream view of the gate; values calculated by RECDES module

For any girder location requested by the user, the RECDES module does a preliminary design for the web, stiffeners, and flanges for an array of girders with web depths varying over a specific range. The ratio of the depth of girder web to the length of the leaf varies from 1/8 to 1/15 (EM 1110-2-2703). For each web depth, RECDES specifies the most economical dimension for the girder elements (based on least weight). A table can be printed showing the variation of the girder weight with web depth for selected locations on the gate.

Three factors influence the design of intercostals located at various elevations in a gate leaf: the hydrostatic load at the bottom of the gate; the composite interaction between the skin plate; and the spacing of the intercostals. The RECDES module will calculate and print a table showing the panel weight for different numbers of intercostals. This information enables the designer to select the best panel designs for the gate.

DES

The design module performs calculations to design a gate leaf. Basic geometry is chosen by the designer, after the designer has considered the results of the RECDES. The designer has the alternative to design either the basic structural elements (which comprise most of the weight of the gate) or the basic and detailed structural elements (Figures 1 and 2).

INV

The investigation module can be used to investigate an existing gate leaf or to verify a design. This module compares the existing strength with the required strength of the specified sections subject to appropriate load combinations. The user has the alternative of investigating either the basic structural elements or the basic and detailed structural elements (Figures 1 and 2).

Analysis Sequence

The analysis sequence for the RECDES, DES, and INV is generally as follows:

a. RECDES.

- (1) Select (input) girders, diaphragms, and intercostal spacing.
- (2) Design skin plate panels and intercostals, and compute girder loads for the selected geometry.
- (3) Design girders for several different web depths.

- (4) Stop program at this stage and review results. Change input data if necessary and reexecute the program.
- (5) Repeat the above steps until the specified uniform load and spacing of the girders are close to the uniform load and spacing calculated by the program. The intercostal spacing and size can also be checked.

b. DES and INV.

- (1) Select input data from RECDES output file.
- (2) Design or investigate intercostals, horizontal girders, skin plate, tapered end section, end diaphragms, and thrust diaphragm.
- (3) Execute quoin post investigation (no design capability).
- (4) Execute diagonal design or investigation.
- (5) Repeat the above steps if necessary.

4 CMITER-LRFD Input Files

The data file for CMITER-LRFD is divided into four groups that will be explained in this chapter. The Group I data are always required, whereas Groups II and III data are for a detailed design or investigation. Group IV data are used to change the default values. Each data line consists of a list name followed by the data items in the list. Any list of values may be continued in the following line. Values to be omitted must be input as a zero.

Group I

Group I is required to run the RECDES, DES, and INV modules. Figure 18 and Table 2 show the data items of Group I. As stated above, Group I is the only data group required to run the RECDES.

The following paragraph explains each variable in Group I. The x-coordinates are measured from the gate contact point toward the miter contact point in a direction parallel with the girder working line. z-coordinates are measured upstream from the downstream edge of the girder web in a direction perpendicular to the work line.

JOB

Data list JOB (heading lines (at least one)). The maximum allowable number of heading (JOB) lines is five. If the title is more than one line, then all except the last line of the title must end with an asterisk. The JOB name should be used in each title line.

RGV

Data list RGV (required overall geometry, vertical). See Figure 18 for illustration. All values are in decimal feet.

RGV = name of data list.

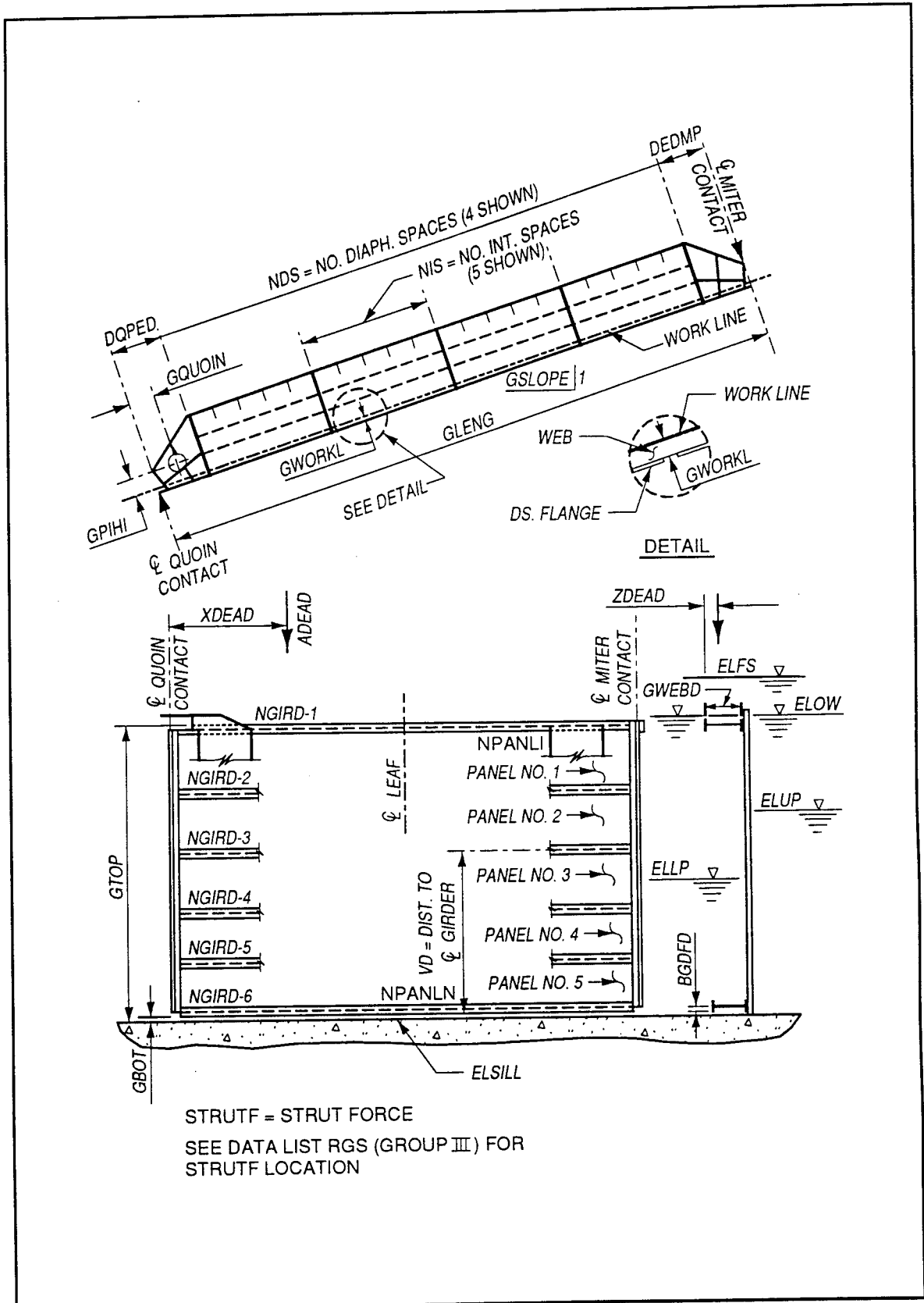

Figure 18. Group I

**Table 2
Data File Group I**

List Name	Names of Data Items in the List					
JOB	Job Description Line					
RGV Figure 18	ELSILL	GBOT	GTOP			
RGL Figure 18	GLENG	GSLOPE	GWORKL	GQUOIN	GPIN1	
GCD Figure 18	GWEBD	DQPED	DEDMP	BGDFD		
GGC Figure 18	NGIRDS					
GWE Figure 18	NGIRD	VD				
GDS Figure 18	NPANLI	NPANLN	NDS	NIS		
RDL Figure 18	ADEAD	XDEAD	ZDEAD	0.0	0.0	
	0.0	0.0	STRUTF			
RWE Figure 18	ELUP	ELLP	ELFS	ELOW		
LCN	LC1	LC2	LC3	LC4	LC5	LC6
RSG Figure 18	FY	FYW	FYF	FYSK	FYS	FYI
	FYQ	FYD	FU			
FAT	LC	CATSK	CATI	CATG	CATEG	

ELSILL = elevation of sill above a given datum (must be positive).

GBOT = distance from sill to bottom of skin plate.

GTOP = distance from sill to overflow elevation at top of gate.

RGL

Data list RGL (require overall geometry, leaf). See Figure 18 for illustration. All values are in decimal feet.

RGL = name of data list

GLENG = length of leaf between contact points.

GSLOPE = tangent of angle between the gate leaf and the lock center line when the gate is in the fully mitered position.

GWORKL = offset from gate leaf working line to downstream edge of girder web.

GQUOIN = distance along gate leaf working line from quoin contact point to gudgeon pin.

GPIN1 = offset from center of gudgeon pin to gate working line.

GCD

Data list GCD (girder geometry common dimensions). See Figure 18 for illustration. All values are in decimal inches. These dimensions are common to all girders.

GCD = name of data list

GWEBD = girder web depth or the clear distance between girder flanges. Assume a value for the first trial ($\frac{L}{15} \leq d \leq \frac{L}{8}$ where L is the girder length).

DQPED = distance from quoin contact point to center of nearest end diaphragm, measured along the gate working line.

DEDMP = distance from center of end diaphragm at miter end of gate to miter contact point, measured along gate working line.

BGDFD = bottom girder downstream flange downward extension below the center line (usual value is 3 in.).

GGC

Data list GGC (girder geometry control). See Figure 18 for illustration.

GGC = name of data list

NGIRDS = number of girders in leaf.

GWE

Data list GWE (girder web elevations). See Figure 17 for illustration. All values are in feet. Repeat the list for each girder.

GWE = name of data list.

NGIRD = girder number (one at top and NGIRDS at bottom of gate).

VD = vertical distance between the sill and the girder web center line.

GDS

Data list GDS (girder diaphragm spacing). Repeat the list for each group of skin plate panels. See Figure 18 for illustration.

GDS = name of data list.

NPANLI = girder number at the top of panel group.

NPANLN = girder number at bottom of panel group.

NDS = number of diaphragm spaces between end diaphragms, along the gate leaf.

NIS = number of intercostal spaces between adjacent diaphragms.

Note: A Panel Group refers to panels that have the same number of intercostals and the same skin plate thickness.

RDL

Data list RDL (required dead loads). Respective units are shown with each item. Coordinates are as described for data list GCD. See Figure 18 for illustration.

RDL = name of data group.

ADEAD = concentrated additional dead load, including mud and ice, bridgeway or walkway, intermediate diaphragm stiffeners, gusset plates, etc., pounds total force. (Gate weight should not be included here.)

XDEAD = distance along gate working line from quoin contact point (x-coordinate) to centroid of ADEAD, feet (A value of zero will set it at the middle of GLENG).

ZDEAD = offset from downstream edge of girder web to centroid (z-coordinate) of ADEAD, inches.

ABUOY = buoyancy force acting on dry weight of gate, pounds (INV module only).

XBUOY = distance along gate working line from quoin contact point (x-coordinate) to centroid of ABUOY, feet (A value of zero will set it at the middle of GLENG) (INV module only).

ZBUOY = offset from downstream edge of girder web to centroid (Z-coordinate) of ABUOY, inches (INV module only).

ALIVE = uniformly applied live load, including walkway and
bridgeway, total pounds (INV module only).

STRUTF = strut capacity force, pounds, applied by strut arm in Load
Case 5 (obstruction).

RWE

Data list RWE (required water elevations). Elevations are in feet
above the same datum as ELSILL. See Figure 18 for illustration.

RWE = name of data list.

ELUP = elevation of upper pool.

ELLP = elevation of lower pool.

ELFS = temporal head elevation.

ELOW = operating water elevation.

LCN

Data list LCN (load combination numbers). Values are one or zero.
Use one to activate the load combination and zero to deactivate the load
combination. (See page 11 for details.)

LCN = name of data list.

LC1,LC2, . . . ,LC6 = load combination numbers.

LC3 = Equation 6 with $I = 0.0$ and $ELLP = 0$

RSG

Data list RSG (required steel grades). Values of yield stress should be
in kips per square inch.

RSG = name of data list.

FY = yield strength of all steel not specifically listed for one of
the other items in the list.

FYW = yield strength of the steel in girder webs.

FYF = yield strength of the steel in the girder flanges.

FYSK = yield strength of the steel in the skin plate.

FYS = yield strength of the steel in the girder stiffeners.

FYI = yield strength of the steel in the intercostal.

FYQ = yield strength of the steel in the quoin post.

FYD = yield strength of the steel in the diagonals.

FU = maximum diagonal tensile strength.

FAT

Data list **FAT** (fatigue load condition and fatigue categories). Fatigue values included in CMITER-LRFD for load condition and fatigue categories are those specified in AISC (1986).

FAT = name of data list.

LC = load condition of the gate.

CATSK = fatigue category of the skin plate.

CATI = fatigue category of the intercostal.

CATG = fatigue category of the girders.

CATGE = fatigue category of the girders at end diaphragm.

Group II

The data in Group II (Table 3) are required to run the INV module. The DES module must be run if the user wants to set the dimensions of the horizontal girders and intercostals. When designed, the data in Group II can be omitted and the program will then calculate these values (Figure 19).

Data list GWT (girder web thicknesses). The minimum thickness for design is established by TMGW in data list DMT (Group IV). Values are in inches. Use once for each group of adjacent girders with the same web thicknesses (see Figure 19 for illustration). Data list DMT in Group IV shows default minimum values and how to change them.

GWT = name of data list.

NGIRDI = girder number at top of group of girders.

NGIRDN = girder number at bottom of group of girders.

GWET = girder web end zone thickness in quoin post area.

GWCT = girder web center zone thickness between end diaphragms.

Table 3 Data File Group II						
List Name	Names of Data Items in the List					
GWT Figure 19	NGIRDI	NGIRDN	GWET	GWCT		
GFU Figure 19	NGIRDI	NGIRDN	GUFEW	GUFET	GUF34W	GUF4CW
	GUFCT	GUCPX	GUCPW	GUCPT		
GFD Figure 19	NGIRDI	NGIRDN	GDFEW	GDFET	GDFCW	GDFCT
	GDCPX	GDCPW	GDCPT			
GFC Figure 19	NGIRDI	NGIRDN	GUFX4	GDFX5		
GWS Figure 19	NGIRDI	NGIRDN	NGWTS	NGLS	GLS1D	GLS1W
	GLS1T	GLS2D	GLS2W	GLS2T	GLS3D	GLS3W
	GLS3T					
ISG Figure 19	NGIRDI	NGIRDN	SPT	ODI	STEMT	FWI
	FTI					

GFU

Data list GFU (girder flange, upstream). The minimum thicknesses for design are established by TMGW in data list DMT (Group IV). Values are in inches. Use once for each group of adjacent girders with the same flange description (see Figure 19 for illustration).

GFU = name of data list.

NGIRDI = girder number at top of group of girders.

NGIRDN = girder number at bottom of group of girders.

GUFEW = girder upstream flange end zone width from girder end to corner splice.

GUFET = girder upstream flange end zone thickness from girder end to corner splice.

GUF34W = girder upstream flange width from corner splice point to flange splice point.

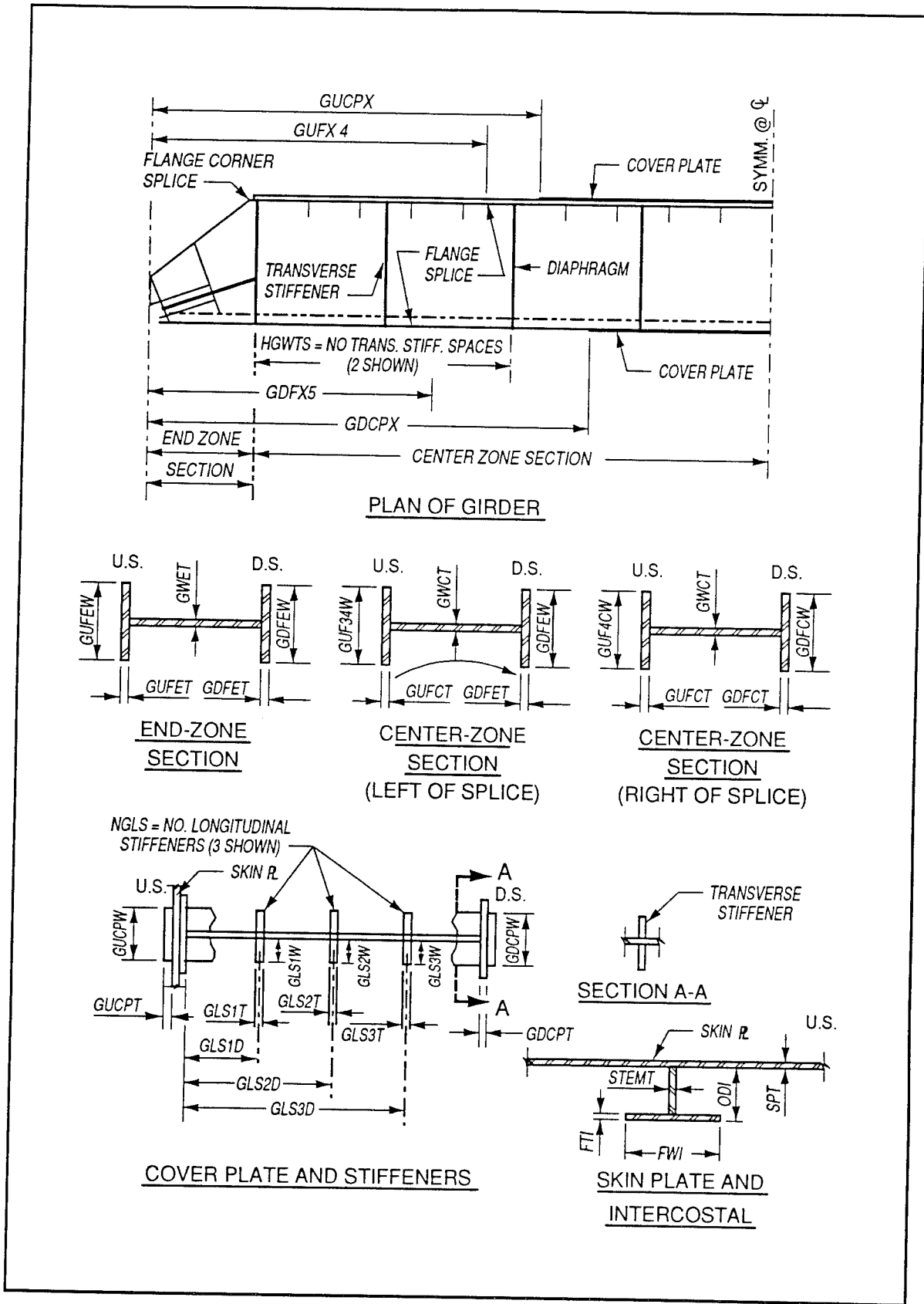

Figure 19. Group II

GUF4CW = girder upstream flange width from flange splice point to girder center line.

GUFCT = girder upstream flange thickness from corner splice point, through flange splice point, to girder center line, and thickness of intermediate diaphragm upstream flange.

GUCPX = girder upstream cover plate end x-coordinate.

GUCPW = girder upstream cover plate width.

GUCPT = girder upstream cover plate thickness.

GFD

Data list GFD (girder flange, downstream). The minimum thicknesses for design are established by TMGW in data list DMT (Group IV). Values are in inches. Use once for each group of adjacent girders with the same flange description (see Figure 19 for illustration).

GFD = name of data list.

NGIRDI = girder number at top of group of girders.

NGIRDN = girder number at bottom of group of girders.

GDFEW = girder downstream flange end zone width from girder end to splice point.

GDFET = girder downstream flange end zone thickness from girder end to splice point.

GDFCW = girder downstream flange center zone width from splice point to girder center line.

GDFCT = girder downstream flange center zone thickness from splice point to girder center line.

GDCPX = girder downstream flange cover plate end x-coordinate.

GDCPW = girder downstream cover plate width.

GDCPT = girder downstream cover plate thickness.

GFC

Data list GFC (girder flange, x-coordinates). Use once for each group of adjacent girders with the same flange description. Dimensions are in inches (see Figure 19 for illustration).

GFC = Name of data list.

NGIRDI = Girder number at top of group of girders.

NGIRDN = Girder number at bottom of group of girders.

GUFX4 = Girder upstream flange x-coordinate of flange splice point.

GDFX5 = girder downstream flange x-coordinate of flange splice point.

GWS

Data list **GWS** (girder web stiffeners). Use once for each group of adjacent girders with the same stiffener description. Dimensions are in inches (see Figure 19 for illustration).

GWS = name of data list.

NGIRDI = girder number at top of group of girders.

NGIRDN = girder number at bottom of group of girders.

NGWTS = number of girder web transverse stiffener spaces between adjacent intermediate diaphragms. Use zero if there are no stiffeners.

NGLS = number of girder longitudinal stiffener pairs to be used. If more than one pair is used, Pair 1 will be upstream of Pair 2, and Pair 2 will be upstream of Pair 3.

GLS1D = girder longitudinal Stiffener 1, distance from upstream edge of web to center of stiffener plate.

GLS1W = girder longitudinal Stiffener 1, width of each plate in the pair. Use negative value if stiffeners are only on one side of web.

GLS1T = girder longitudinal Stiffener 1, thickness of each plate.

GLS2D = girder longitudinal Stiffener 2, distance from upstream edge of web to center of stiffener plate in Pair 2. Must be less than **GLS1D**. Use zero if **NGLS** is less than two.

GLS2W = girder longitudinal Stiffener 2, width of each plate in the pair. Use negative value if stiffeners are only on one side of web. Use zero if **NGLS** is less than two.

GLS2T = girder longitudinal Stiffener 2, thickness of each plate. Use zero if **NGLS** is less than two.

GLS3D = girder longitudinal Stiffener 3, distance from upstream edge of web to center of stiffener plate in Pair 2. Must be less than **GLS2D**. Use zero if **NGLS** is less than three.

GLS3W = girder longitudinal Stiffener 3, width of each plate in the pair. Use negative value if stiffeners are only on one side of web. Use zero if **NGLS** is less than three.

GLS3T = girder longitudinal Stiffener 3, thickness of each plate. Use zero if NGLS is less than three.

ISG

Data list ISG (intercostal and skin plate geometry). ISG defines the intercostal size and spacing and skin plate thickness for both investigation and design. Repeat the list for each group of skin plate panels (see Figure 19 for illustration).

ISG = name of data list.

NGIRDI = girder number at top of group of girders.

NGIRDN = girder number at bottom of group of girders.

SPT = skin plate thickness. The minimum thickness for design is established by TMSP in data list DMT (Group IV). All values are in inches.

ODI = overall depth of intercostal stem, including FTI, perpendicular to skin plate.

STEMT = thickness of intercostal stem.

FWI = flange width of intercostal (T-section).

FTI = flange thickness of intercostal (T-section).

Group III

The data in Group III (Table 4) are required to run the DES module if the design of the following detailed elements is desired: end diaphragms, quoin post, thrust diaphragm, tapered end section, and diagonals (Figures 20 and 21). The items marked with an asterisk may be entered as zero and the program will calculate them.

RGS

Data list RGS (required geometry for struts). All values are in decimal feet (See Figure 21 for illustration).

RGS = name of data list.

GSTRT1 = distance along gate working line from gudgeon pin to strut pin, at top girder.

GSTRT3 = vertical distance from center line of top girder up to strut connection point.

**Table 4
Data File Group III**

List Name	Names of Data Items in the List					
RGS Figure 21	GSTRT1	GSTRT3				
RED Figure 20	EDT*	EDUFW	EDDFW	EDDFT		
RID Figure 20	DUFW	DDFW	DDFT	DWT		
RQP Figure 20	GUFX3	TDSLOC	CPLOC	CPUW	QCPT	QCPSW
	QCPST	QTDT*	QDST	QDSUFW	QDSDFW	QDSFT
	TDHSA					
RDH Figure 21	NDPH	DX1Q	DX1M	DX2Q	DX2M	DX3Q
	DX3M					
RDV Figure 21	NDPV	DTD	DBU	NDG1	DG1U	DG1D
	NDG2	DG2U	DG2D			
RDW	DDSN	DDSP				

RED

Data list RED (required end diaphragm description). All values are in inches (Figure 20).

RED = name of data list.

EDT = end diaphragm web thickness. For design purposes use a value of zero.

EDUFW = end diaphragm upstream flange width.

EDDFW = end diaphragm downstream flange width.

EDDFT = end diaphragm downstream flange thickness. (Upstream flange thickness is GUFCT in data list GFU (Group II).)

RID

Data list RID (required intermediate diaphragm description). All values are in inches (Figure 20).

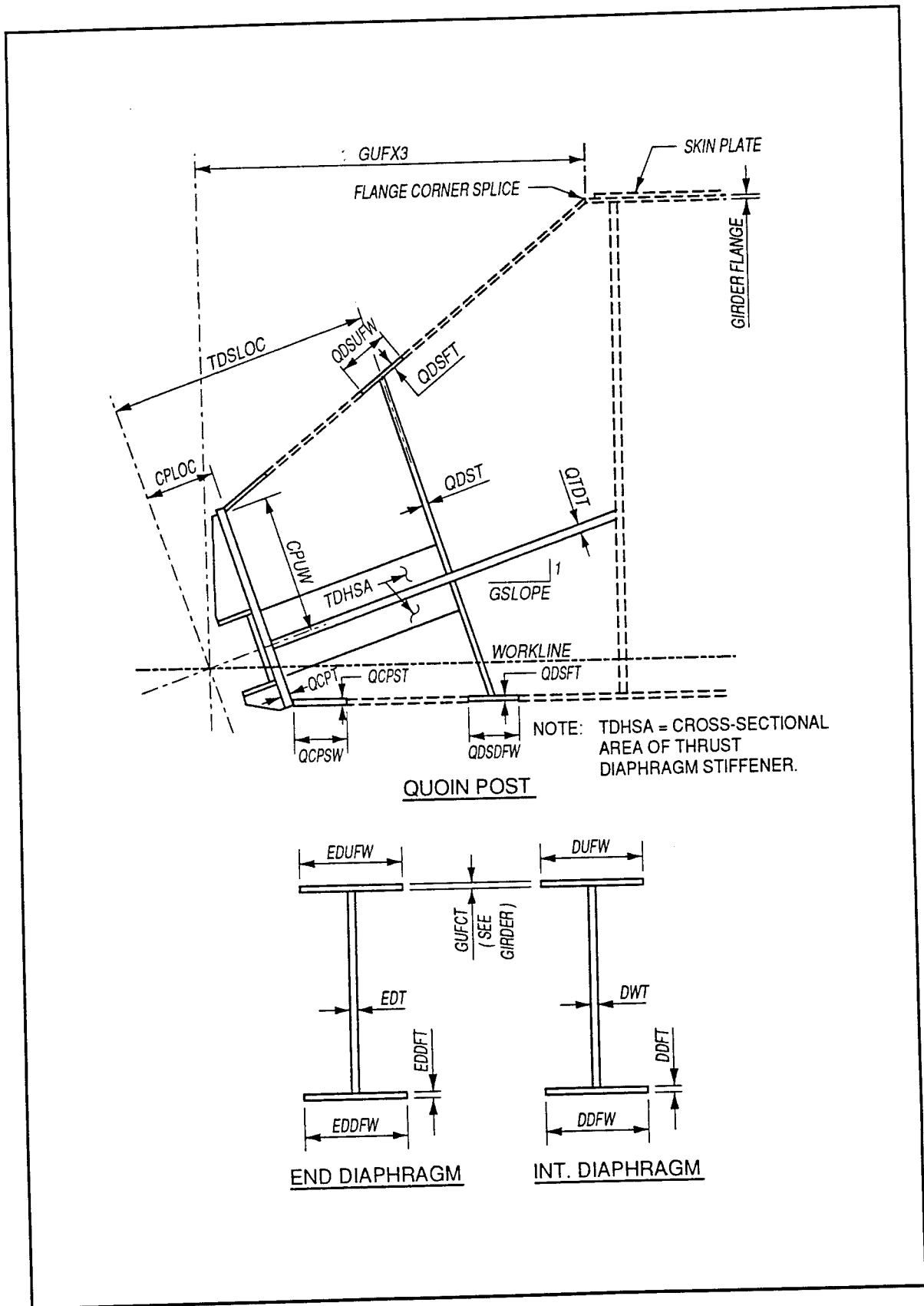

Figure 20. Group III, quoin, tapered end, and end diaphragm data

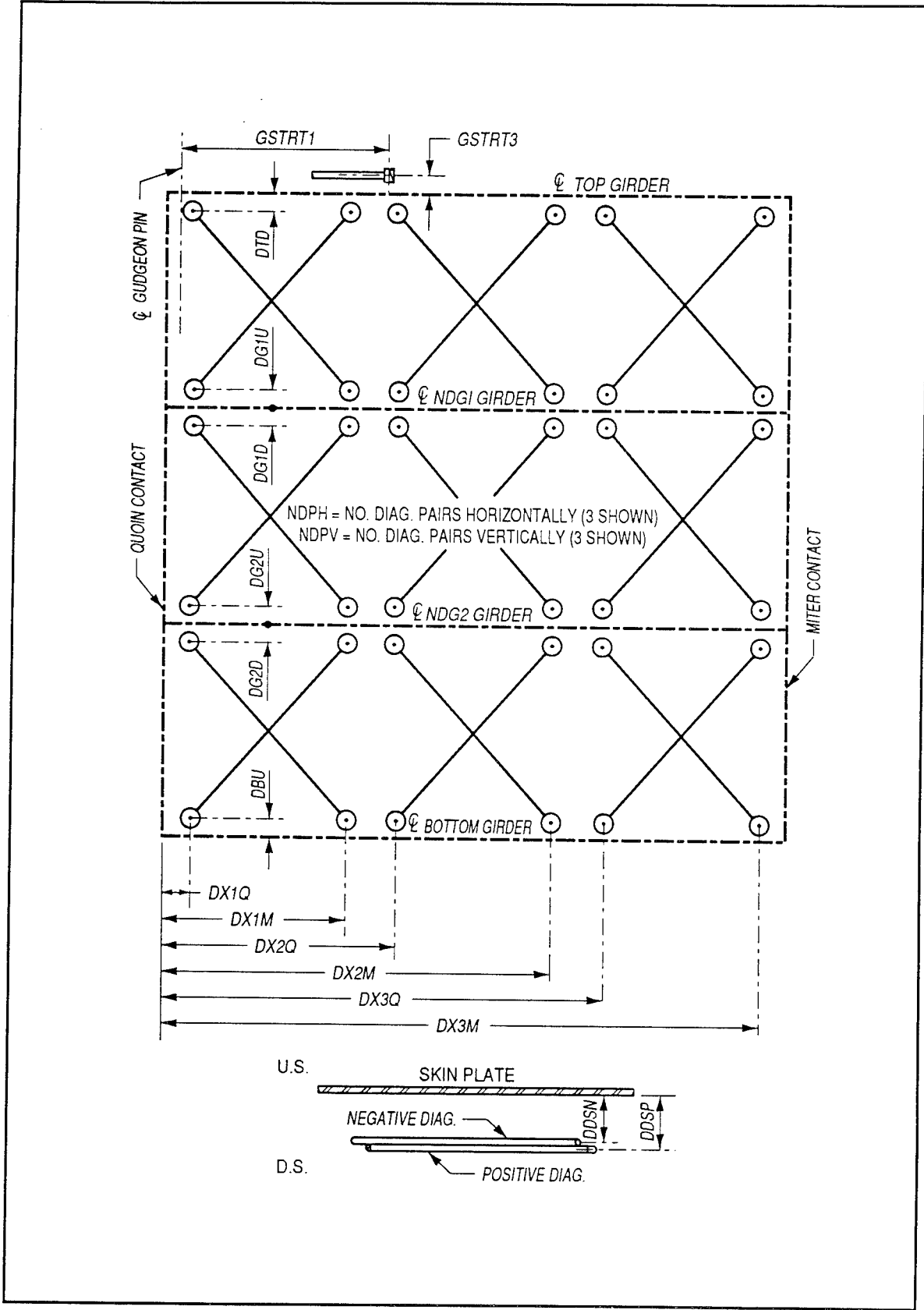

Figure 21. Group III, diagonals

RID = name of data list.

DUFW = diaphragm upstream flange width.

DDFW = diaphragm downstream flange width.

DDFT = diaphragm downstream flange thickness. (The upstream flange thickness is set by GUFCT in data list GFU (Group II).

DWT = Diaphragm web thickness.

RQP

Data list RQP (required data for quoin post). All values are in inches except TDHSA, which is in square inches (Figure 20).

RQP = name of data list.

GUFX3 = girder upstream flange x-coordinate of corner splice point.

TDSLOC = thrust diaphragm stiffener plate location, distance along thrust diaphragm from quoin contact point to center of thrust diaphragm stiffener plate.

CPLOC = distance along line of thrust diaphragm from quoin contact point to the inside edge of the end plate.

CPUW = quoin post contact plate width from center line of the thrust diaphragm to upstream corner of the end plate. The downstream partial width is calculated by the program.

QCPT = quoin post contact plate thickness.

QCPSW = quoin post contact plate stiffener width.

QCPST = quoin post contact plate stiffener thickness.

QTDT = quoin post thrust diaphragm thickness. A value of zero will cause the QTDT to be selected by the program.

QDST = quoin post thrust diaphragm stiffener plate thickness.

QDSUFW = quoin post thrust diaphragm stiffener plate upstream flange width. Use a value of zero to omit the upstream half of the stiffener plate and its flange.

QDSDFW = quoin post thrust diaphragm stiffener plate downstream flange width. Use a value of zero to omit the downstream half of the stiffener plate and its flange.

QDSFT = quoin post thrust diaphragm stiffener plate flange thickness.

TDHSA = thrust diaphragm horizontal stiffener cross-section area, square inches. This stiffener is horizontal, extending from

the contact plate to the end diaphragm, located halfway up in the space between girder webs. Use a value of zero to omit this plate.

RDH

Data list RDH (required diagonal geometry, horizontal). This data list describes the x-coordinates along the gate working line from the quoin contact point to the ends of diagonals and the eccentricities normal to the skin plate. The x-coordinate values shown in brackets in this group are in pairs, one pair of coordinate values for each pair of diagonals horizontally (Figure 21). All x-coordinates are in inches.

RDH = name of data list.

NDPH = number of diagonal pairs, horizontally (three maximum).

DX1Q = x-coordinate of diagonal pair end toward the quoin, first pair.

DX1M = x-coordinate of diagonal pair end toward the miter end, first pair.

DX2Q = x-coordinate of diagonal pair end toward the quoin, second pair.

DX2M = x-coordinate of diagonal pair end toward the miter end, second pair.

DX3Q = x-coordinate of diagonal pair end toward the quoin, third pair.

DX3M = x-coordinate of diagonal pair end toward the miter end, third pair.

RDV

Data list RDV (required diagonal geometry, vertical). This data list describes the vertical relationship between the diagonal ends and the gate vertical geometry (Figure 21). Values are in inches.

RDV = name of data list.

NDPV = number of diagonal pairs, vertically.

DTD = distance from topmost girder web down to highest diagonal end.

DBU = distance from bottom girder web up to lowest diagonal end.

NDG1 = girder number at the bottom of the topmost diagonal pair panel (use if NDPV is two or three).

DG1U = distance from the web of the girder NDG1 up to lower end of diagonal pair in the topmost diagonal panel (use if NDPV is two or three).

DG1D = distance from the web of the girder NDG1 down to the upper end of diagonal pair in the diagonal panel immediately below the girder (use if NDPV is two or three).

NDG2 = girder number at the top of the bottom diagonal panel, the third diagonal panel (use if NDPV is three).

DG2U = distance from the web of the girder NDG2 up to lower end of diagonal pair in the middle diagonal panel.

DG2D = distance from the web of the girder NDG2 down to the upper end of diagonal pair in the bottom diagonal panel.

RDW

Data list RDW (required diagonal geometry). This data list defines the horizontal offset from the skin plate to the diagonals. Values are in inches (Figure 21).

RDW = name of data list.

DDSN = distance from downstream face of skin plate to center line of negative diagonals.

DDSP = distance from downstream face of skin plate to center line of positive diagonals.

Group IV

Group IV (Table 5) is required only if the user wants to change the default values used for certain items and when load combination six is active.

Table 5 Data File Group IV						
List Name	Names of Data Items in the List					
DMT	TMSP	TMED	TMI	TMGW	TMGF	
DEF	HEAD1	HEAD2	OBSLOC	THEAD	OWP	UWW
	EQAF	USYM	SYM			

DMT

Data list DMT (design minimum thickness). Each item in this list includes the default value that is specified if the list is not entered. Values are in inches.

DMT = name of the data group.

TMSP = minimum thickness of skin plate (SPT in data list ISG (Group II)). Default value = 0.375 in.

TMED = minimum thickness of end diaphragms (EDT in data list RED (Group III)). Default value = 0.5 in.

TMI = minimum thickness of intercostal (data list ISG (Group II)). Default value = 0.375 in.

TMGW = minimum thickness of girder webs (GWET and GWCT in data list GWT (Group II)). Default value = 0.375 in.

TMGF = minimum thickness of girder flanges (Data groups GFU and GFD (Group II)). Default value = 0.5 in.

DEF

Data list DEF (default values for load data). This data list allows changing the default values for hydraulic and impact load data.

DEF = name of the data group.

HEAD1 = feet of water to be used as a minimum head for analysis of skin plate. Default value = 6.0 ft.

HEAD2 = feet of water to be used as a minimum head for impact analysis of girders in ASD criteria. A value of zero is used in LRFD criteria.

OBSLOC = obstruction location radius from pintle, feet. If not changed by data group DEF, the default value will be placed at the miter point. Use any number if STRUTF = 0.

THEAD = temporal head, feet of water, applied from the full submergence elevation ELFS down to the gate bottom. Default value = 1.25 ft.

OWP = operating water pressure, pounds per square inch, applied from the operating water elevation ELOW to the gate bottom. Default value = 30.0 psf.

UWW = unit weight of water, pounds per cubic foot. Default value = 62.5 pcf.

EQAF = earthquake acceleration factor to be used in Westergaard's equation to determine dynamic water pressures. Default value = 0.05.

UNSYM = unsymmetric impact load, kips. Default value = 250.0 kips.

SYM = symmetric impact load, kips. Default value = 400.0 kips.

5 Example Problem

Scope

This chapter presents an example that will help to create and clarify the input and output files for each module, the program execution that explains how to run and interact with the program, the hand calculation procedure for each structural element, and the computer results.

This example, the Miter Gate at Lock and Dam No. 3 on Red River Waterway, has an 84-ft-wide lock, with a differential head of 31 ft. The example will design the lower miter gate, an intercostal plate section and a girder noncompact section. Program results for the example are shown in Appendix A.

Example, Lower Miter Gate

RECDES module input file

The input file used in this example to run the RECDES module includes Groups I and IV. See Figures 18, 22, and 23 for illustrations.

The input files in this example represent the optimum files. Note that the program has been run previously to have the following files:

JOB Lock and Dam #3*
JOB 84-ft-wide Lock. *
JOB Load and Resistance Factor Design*
JOB March 1,1993
RGV 46.0000, 0.3333, 56.5417
RGL 48.2500, 3.0000, 0.3333, 1.25, 1.9792
GCD 0.0, 49.500, 49.500, 3.000
GGC 12

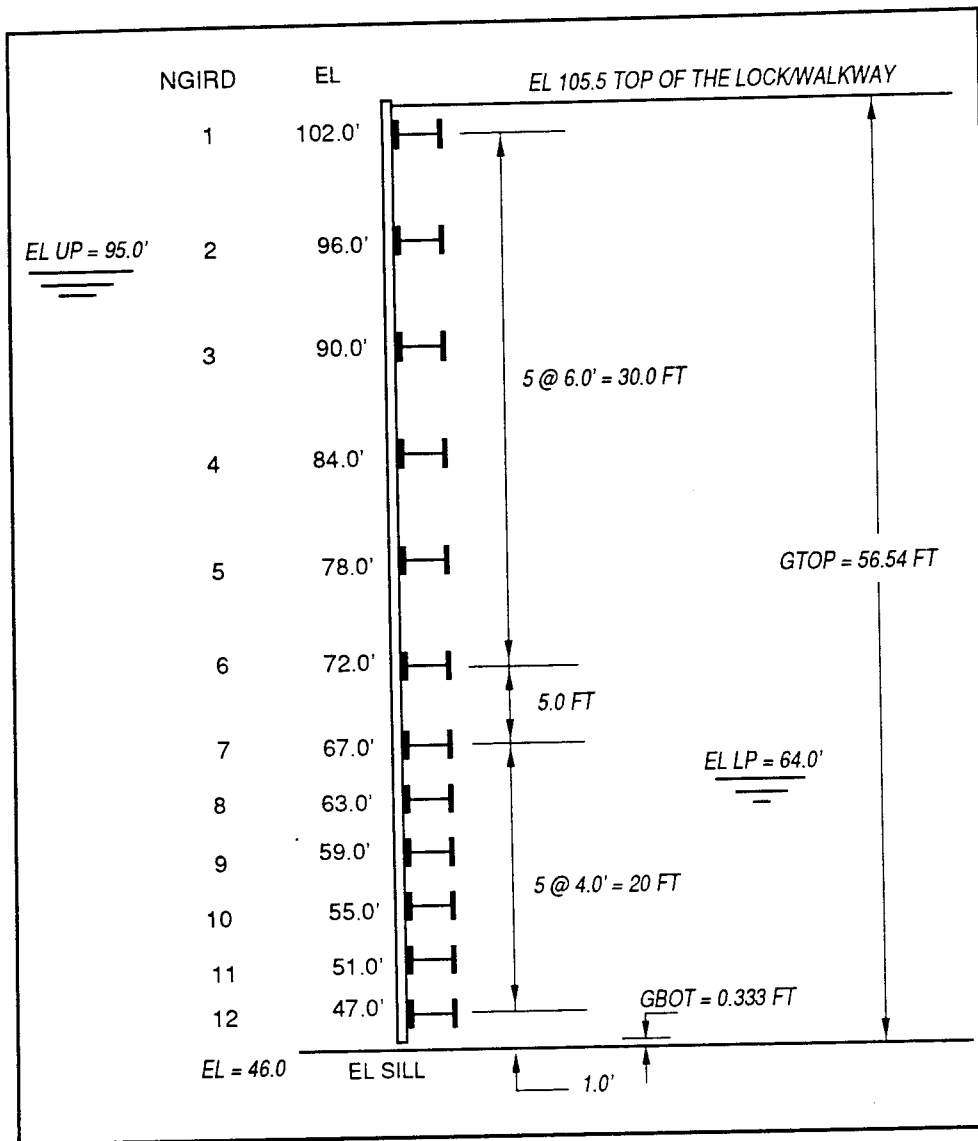

Figure 22. Vertical cross section

- GWE 1, 56.000
- GWE 2, 50.000
- GWE 3, 44.000
- GWE 4, 38.000
- GWE 5, 32.000
- GWE 6, 26.000
- GWE 7, 21.000
- GWE 8, 17.000
- GWE 9, 13.000
- GWE 10, 9.000
- GWE 11, 5.000

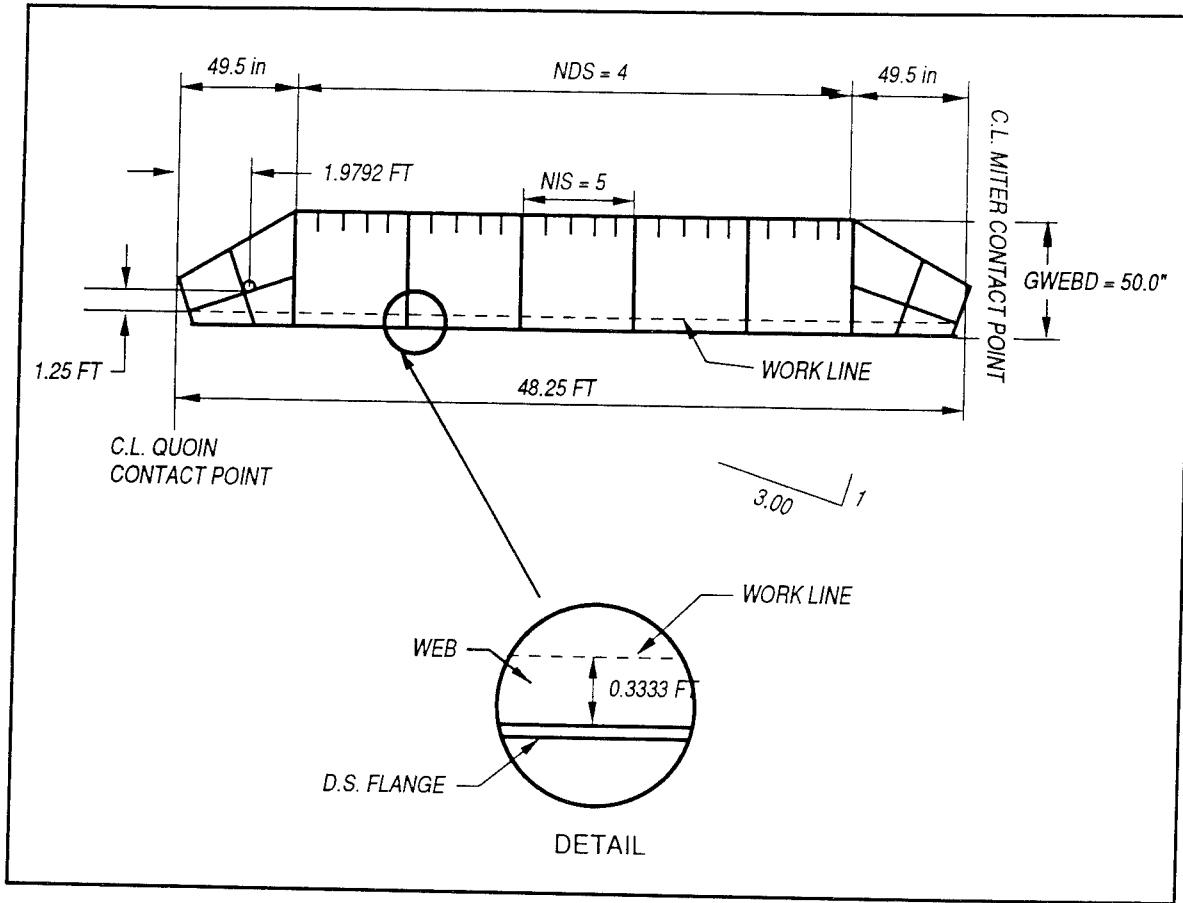

Figure 23. Top view girder

GWE 12, 1.000
 GDS 1, 11, 4, 0
 RDL 185000, 24.125, 25.5, 0, 0, 0, 0, 256000.0
 RWE 95.0, 64.0, 105.5, 95.0
 LCN 1, 1, 0, 0, 0, 1
 RSG 36.0, 36.0, 36.0, 36.0, 36.0, 36.0, 0, 0, 0
 FAT 2, 4, 2, 4, 4
 DMT 0.5, 0.5, 0.375, 0.5, 0.5
 DEF 6.0, 0, 46.3, 1.25, 30.0, 62.428, 0.05, 250., 400.

RECDES module program execution

To run the RECDES module, type "x0101" from the prompt. The program will start to interact with the user and will display the following prompts:

- Enter input file data.

- The input file can be made using any text editor in ASCII format and the name should be entered here.
- Enter output file name.
 - File name where the results should be written to.
- Enter minimum and maximum girder spacing.
 - The spacing of the girder to have the same uniform loads will be found with these two values. The values should be between 4 and 7 ft (EM 1110-2-2703).
- Enter panel number desired or “0” for all panels.
 - The user can select the panels to investigate, or all the panels will be available if “0” is selected.
- What girder section do you want to design?
 - 1. Compact section
 - 2. Noncompact section
 - User shall select “1” or “2” corresponding to the section to be designed.

RECDES module output file

The output files of the example are included in Appendix A. The output file of the RECDES module is listed as:

- a. Required input data.* All the data from the input file are in this section with a corresponding description.
- b. Recommended girder location's table to yield approximately equal loads.* The program determines the best girder location using load combination 1. The best girder location occurs when the girders have reached approximately equal loads.
- c. Girder load table.* With the girder position from the input file, the program finds the loads acting in each girder for the active load combinations. Here the designer has to compare the results in the tables with the results of the recommended girder locations table and redefine the input file if necessary to reach the same uniform load in each girder.
- d. Recommended skin plate thickness and intercostal size and spacing to determine the optimum weight.* The output file tables suggest a

skin plate thickness for different numbers and sizes of intercostals. Here the designer should decide what is the best combination of skin plate and intercostal. This decision can be made using the total panel weight.

- e. *Recommended girder web depth.* The output file tables suggest different girder web depths for each girder. The designer has to decide the best alternative by checking the weight of the girders.
- f. *Total weight of the girders with the same web depth.* This output file table is the summation of the weight of each girder with the same web depth. These output tables provide the user with a better idea of which girder web depth should be used in the design module.

DES module input file

The input file used in this example to run the DES module includes Groups I, III, and IV. See Figures 18, 20, 21, and 24 for illustrations.

JOB Lock and Dam #3*
JOB 84-Ft-Wide Lock.*
JOB Load and Resistance Factor Design*
JOB March 1,1993
RGV 46.0000, 0.3333, 56.5417
RGL 48.2500, 3.0000, 0.3333, 1.9792, 1.25
GCD 50.000, 49.500, 49.500, 3.000
GGC 12

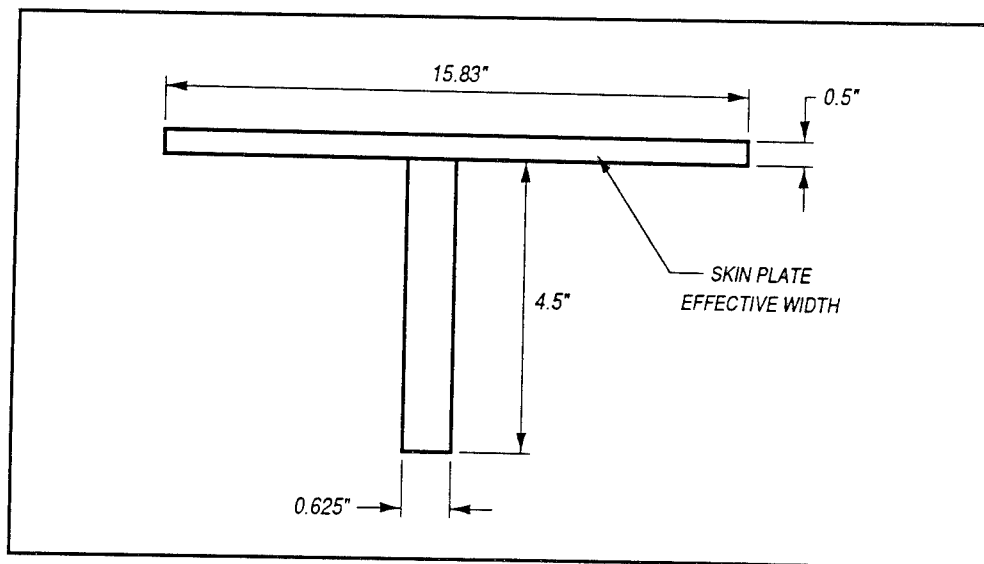

Figure 24. Intercostal section

GWE 1, 56.000
 GWE 2, 50.000
 GWE 3, 44.000
 GWE 4, 38.000
 GWE 5, 32.000
 GWE 6, 26.000
 GWE 7, 21.000
 GWE 8, 17.000
 GWE 9, 13.000
 GWE 10, 9.000
 GWE 11, 5.000
 GWE 12, 1.000
 GDS 1, 11, 4, 5
 RDL 185000, 24.125, 25.5, 0, 0, 0, 0, 256000.0
 RWE 95.0, 64.0, 105.5, 95.0
 LCN 1, 1, 0, 1, 1, 1
 RSG 36.0, 36.0, 36.0, 36.0, 36.0, 36.0, 36.0, 60.0, 75.0
 FAT 2, 4, 2, 4, 4
 RGS 19.1667, 1.25
 RED 0.0, 4.0, 4.0, 0.5
 RID 4.0, 4.0, 0.5, 0.5
 RQP 47.5, 31.0, 7.0, 11.0, 1.0, 6.0, 0.5, 1.0, 1.00, 6.0, 6.0, 0.5, 0.0
 RDH 1, 77.5, 501.5, 0., 0., 0., 0.
 RDV 1, 36.75, 36.75, 0., 0., 0., 0, 0., 0.
 RDW 57.375, 58.375
 DMT 0.5, 0.5, 0.375, 0.5, 0.5
 DEF 6.0, 0, 46.3, 1.25, 30.0, 62.428, 0.05, 250., 400.

DES module program execution

To run the design module, type “x0102” from the prompt. After this, the program will start to interact with the user and will display the following prompts:

- Enter input file data.
- Enter output file name.
- What girder section do you want to design?

- 1. Compact section, or
- 2. Noncompact section.

DES module output file

The DES module output file provides the required widths and thicknesses of all plates used to build the elements of the gate and are listed as:

- a. *Required input data.* All the data from the input file are in this section with a corresponding description.
- b. *Skin plate design.*
- c. *Intercostal design.*
- d. *Girder design.* This output file table shows the dimensions required for the center line and end diaphragm section.
- e. *Flange splice distances.* These are the distances to the splice point on the girder flanges from the contact point.
- f. *Web stiffeners.*
- g. *End diaphragm design.*
- h. *Quoin post design.*
- i. *Thrust diaphragm design.*
- j. *Tapered end design.*
- k. *Diagonal design.*
- l. *Gate properties.*

INV module input file

The input file to run the investigation module includes the four data groups. The input file used is the same as the input file used in the design module, along with Group II as follows:

GWT 1, 5, 0.5, 0.5
 GWT 6, 12 0.625, 0.5
 GFU 1, 11, 8.0, 0.5, 12.0, 12.0, 0.5, 0, 0, 0
 GFU 12, 12 10.0, 0.5, 12.0, 12.0, 0.5, 0, 0, 0
 GFD 1, 11, 12.0, 0.5, 12.0, 0.5, 0., 0., 0.

GFD 12, 12, 10.5, 0.5, 9.0, 0.5, 0., 0., 0.
GFC 1, 3, 49.5, 62.5
GFC 4, 11, 49.5, 0.
GFD 12, 12, 49.5, 61.5
GWS 1, 12, 0, 2, 16.5, 5.5, 0.5, 33.0, 5.5, 0.5, 0, 0, 0
ISG 1, 3, 0.5, 3.5, 0.625, 0, 0
ISG 4, 6, 0.5, 5.5, 0.625, 0, 0
ISG 7, 12, 0.5, 4.5, 0.625, 0, 0

INV module program execution

To run the investigation module, type "x0103" from the prompt. After this, the program will ask the following question.

- What design method do you prefer?
 - 1. Allowable stress design
 - 2. Load and resistance factor design

INV module output file

The investigation module output file will provide the user with the strength of the basic and detailed structural sections, which are listed as:

- a. *Required input data.* All the data from the input file are reported in this section with a corresponding description.
- b. *Skin plate investigation.* This section includes the panel dimensions and the stress, deflection, and stress range produced for the active load combinations. Also, it includes the flexure, fatigue, and deflection strengths.
- c. *Intercostal investigation.* This section includes the intercostal dimensions and the moment produced for a fixed and pinned section by the active load combinations. The flexure strength is also included.
- d. *Girder investigation.* This section shows the dimensions, properties, acting forces, and strengths in the different sections of the girder (Figure 25).
- e. *End diaphragm investigation.*
- f. *Quoin post investigation.*

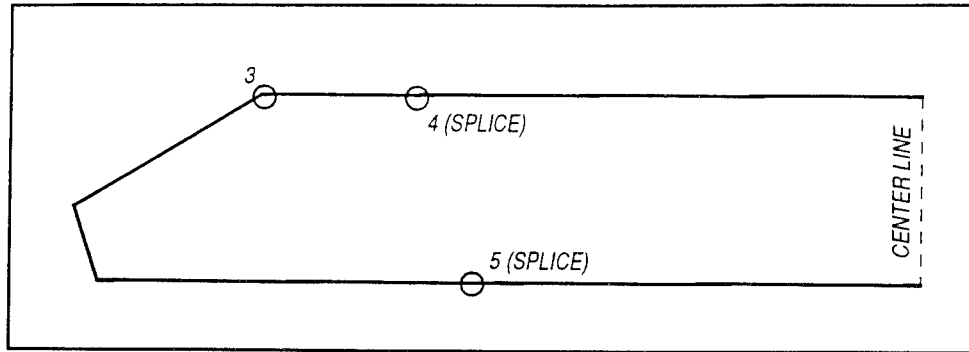

Figure 25. Plate girder investigation points

- g. Thrust diaphragm investigation.*
- h. Tapered end investigation.*
- i. Diagonal investigation.*
- j. Gate properties.*

Hand Calculations

Hand calculations were performed and are presented in this section. This example used the same values used in the investigation module input file and the results will be compared with the values of the investigation module output file (Appendix A). Figures 22-24 show the example layout. Criteria to design each structural element were explained in Chapter 2.

Structural analysis

Tables 6 and 7 show the individual loads and load combinations acting on the girders, and Tables 8 and 9 show the same data for the panels.

Skin plate design

The skin plate is designed as a fixed plate at the center line of the intercostals and the edges of the girder flanges. For Panels 7-12 (Figure 23) horizontal girders are spaced 4 ft apart, and intercostals are spaced on 24-in. centers. With 6-in.-wide girder flanges the plate dimensions are (see Chapter 2 for details):

$$a = 36 \text{ in.}$$

$$b = 24 \text{ in.}$$

Girder	H_s kips/ft ²	H_s kips/ft	H_t kips/ft ²	H_t kips/ft	E kips/ft ²	E kips/ft
1	0.0	0.0	0.0	0.0	0.0	0.0
2	0.0	0.13	0.078	0.156	0.0	0.0
3	0.31	1.870	0.078	0.429	0.043	0.26
4	0.68	4.12	0.078	0.468	0.063	0.38
5	1.06	6.36	0.078	0.468	0.079	0.47
6	1.25	7.10	0.078	0.429	0.092	0.50
7	1.42	7.79	0.078	0.351	0.101	0.45
8	1.73	7.71	0.078	0.312	0.119	0.48
9	1.935	7.75	0.078	0.312	0.141	0.56
10	1.935	7.75	0.078	0.312	0.156	0.62
11	1.935	7.75	0.078	0.312	0.169	0.67
12	1.935	5.805	0.078	0.234	0.180	0.54

Girder No.	$1.4H_s + 1.0H_t$ kips/ft (Equation 7)	$1.2H_s + 1.0E$ kips/ft (Equation 10)
1	0.00	0.00
2	0.331	0.175
3	3.067	2.503
4	6.238	5.327
5	9.380	8.112
6	11.365	9.872
7	11.264	9.809
8	11.103	9.725
9	11.156	9.853
10	11.156	9.913
11	11.156	9.964
12	8.361	7.504

**Table 8
Panel Unfactored Loads**

Panel No.	H_s kips/ft ²	H_t kips/ft ²	E kips/ft ²
1	0.375	0.0	0.00
2	0.375	0.078	0.027
3	0.499	0.078	0.054
4	0.874	0.078	0.072
5	1.249	0.078	0.086
6	1.592	0.078	0.097
7	1.873	0.078	0.105
8	1.935	0.078	0.132
9	1.935	0.078	0.149
10	1.935	0.078	0.162
11	1.935	0.078	0.175

**Table 9
Panel Load Combinations**

Panel No.	$1.4H_s + 1.0H_t$ kips/ft ²	$1.2H_s + 1.0E$ kips/ft ²
1	0.525	0.449
2	0.602	0.477
3	0.777	0.653
4	1.302	1.120
5	1.826	1.584
6	2.307	2.007
7	2.700	2.352
8	2.787	2.454
9	2.787	2.471
10	2.787	2.485
11	2.787	2.497

$$W_u = 2.787 \text{ kips/ft}^2 = 0.0194 \text{ ksi}$$

$$W = 1.935 \text{ kips/ft}^2 = 0.0134 \text{ ksi}$$

$$F_y = 36.0 \text{ ksi}$$

$$F_r = 21\text{-ksi load condition 2, category C (Appendix K of AISC (1986))}$$

$$\alpha = 0.9$$

$$\phi = 0.9$$

where

W_u = skin plate factored load, ksi

W = skin plate unfactored load, ksi

F_y = skin plate yield strength, ksi

F_r = fatigue stress, ksi

α = reliability factor (see Chapter 2 for details)

ϕ = resistance factor (see Chapter 2 for details)

- a. *Required-thickness-based yield limit state.* Equation 11 should be used to determine the skin plate thickness with $F = \alpha\phi F_y$, $W = W_u$, $\alpha = 0.9$, and $\phi = 0.9$

$$t_{\min} = \sqrt{\frac{0.5Wb^2}{F \left[1 + 0.623 \left(\frac{b}{a} \right)^6 \right]}} \quad (68)$$

$$t_{\min} = \sqrt{\frac{0.5(0.0194)(24)^2}{29.16 \left[1 + 0.623 \left(\frac{24}{36} \right)^6 \right]}} = 0.426 \text{ in.} \quad (69)$$

use $t = 0.5$ in. (check with program to verify results)

Stress using $t = 0.5$ in. is:

$$\sigma = \frac{0.5W_u b^2}{t^2 \left[1 + 0.623 \left(\frac{b}{a} \right)^6 \right]} \quad (70)$$

$$\sigma = \frac{(0.5)(0.0194) 24^2}{0.5^2 \left[1 + 0.623 \left(\frac{24}{36} \right)^6 \right]} = 21.14 \text{ ksi} \quad (71)$$

which is less than $\alpha\phi F_y = 29.16$ ksi. Therefore, the skin plate with a thickness of 0.5 in. is acceptable for the yield limit state.

- b. *Deflection check.* Equation 12 should be used to calculate the deflection with $t = 0.5$ in. and $\delta_{all} = 0.4t$

$$\delta = \frac{0.0284 W b^4}{\left[1 + 1.056 \left(\frac{a}{b} \right)^5 \right] E t^3} \quad (72)$$

$$\delta = \frac{0.0284(0.0134) (24)^4}{\left[1 + 1.056 \left(\frac{24}{36} \right)^5 \right] (29000) (0.5)^3} = 0.0306 \text{ in.} \quad (73)$$

which is less than $\delta_{all} = 0.4t = 0.2$ in. Therefore, the skin plate with a thickness of 0.5 in. is acceptable for deflection criteria.

- c. *Minimum thickness required by fatigue.* Equation 11 should be used to determine the skin plate thickness with $F = F_r$, $W = W$

$$t_{fat} = \sqrt{\frac{0.5 (0.0134) (24)^2}{21 \left[1 + 0.623 \left(\frac{24}{36} \right)^6 \right]}} = 0.417 \text{ in.} \quad (74)$$

The minimum thickness required by fatigue is 0.417 in.; use $t = 0.5$ in. (check with program to verify results). Fatigue stress using $t = 0.5$ in. is:

$$\sigma_f = \frac{0.5 W b^2}{t^2 \left[1 + 0.623 \left(\frac{a}{b} \right)^6 \right]} \quad (75)$$

$$\sigma_f = \frac{(0.5)(0.0134)24^2}{0.5^2 \left[1 + 0.623 \left(\frac{24}{36} \right)^6 \right]} = 14.68 \text{ ksi} \quad (76)$$

which is less than $F_r = 21.0$ ksi. Therefore, the skin plate with a thickness of 0.5 in. is acceptable for fatigue criteria.

Note that the skin plate with a thickness of 0.5 in. is also acceptable for yield limit state, deflection, and fatigue. Therefore, the skin plate with a thickness of 0.5 in. is acceptable.

Intercostal design

This example designs the intercostals in panels 7 through 11 (Figures 22 and 23) using pin-support conditions and a plate section (Figures 7 and 8). The intercostals are spaced on 24.0-in. centers, and have a 48-in.-long girder center line spacing ($G = 48.0$ in.). The load is applied as a trapezoidal distribution as shown in Figure 8 (see Chapter 2 for details). The top and bottom girders have flanges with $F/2 = 6.0$ in., $S = 36$ in., $a = 12$ in., and $b = 12$ in. (see Figure 8 for details). The required factor moment capacity for the intercostal subjected to the trapezoidal load is $M_u = 97.549$ kip-in. (SBM in Figure 8, check with program to verify).

The effective width of the skin plate is determined assuming that the skin plate is an unstiffened, noncompact element under compression (AISC 1986). The width-to-thickness ratio to satisfy this requirement is:

$$\lambda = \frac{b}{2t_f} \leq \lambda_r = \frac{95}{\sqrt{F_y}} \quad (77)$$

The effective width b_e of a 0.5-in.-thick plate is then,

$$b_e = \frac{2t_f(95)}{\sqrt{F_y}} = \frac{2(0.5)(95)}{\sqrt{36}} = 15.83 \text{ in.} \quad (78)$$

The chosen intercostal section (Figure 24) is a plate section with a 4.5-in. stem and 0.625-in. thickness that produces a T-section in combination with the effective width (15.83 in.) of the skin plate ($t = 0.5$ in.). In accordance with EM 1110-2-2105, the stem satisfies noncompact requirements.

$$\frac{d}{t} = \frac{6.0}{0.75} = 8.0 < \frac{127}{\sqrt{F_y}} = 21.2 \quad (79)$$

In accordance with Chapter 2, the nominal strength $M_n = M_y$, $\lambda < \lambda_r$, and the compression flange has continuous lateral support ($L_b = 0$). The section has an area of 10.73 in.², a moment of inertia I_x of 17.91 in.⁴, a minimum section module $S_x = 4.37$ in.³, and a yield moment of $M_y = 157.5$ kip-in. The design strength is:

$$\alpha\phi M_y = (0.9)(0.9) 157.2 = 127.3 \text{ kip-in.}$$

which exceeds the required $M_u = 97.545$ kip-in. Therefore, a 4.5- by 0.625-in. stem is acceptable.

Girder design

This example applies to the design of the required cross section at the end diaphragm and center span of the critical horizontal girder (girders 6-11 of Figure 22) for the miter gate leaf. The required leaf span from the quoin block to miter block is 48.25 ft (579.0 in.), with a 50-in. web depth (Figure 26). Uniform load and reactions are shown in Figure 9. The girder is subject to reverse bending. However, at the center span, the upstream flange is in compression, whereas it is in tension in the end diaphragm section. The upstream flange is fully laterally supported by the skin plate. The downstream flange is braced against lateral displacement

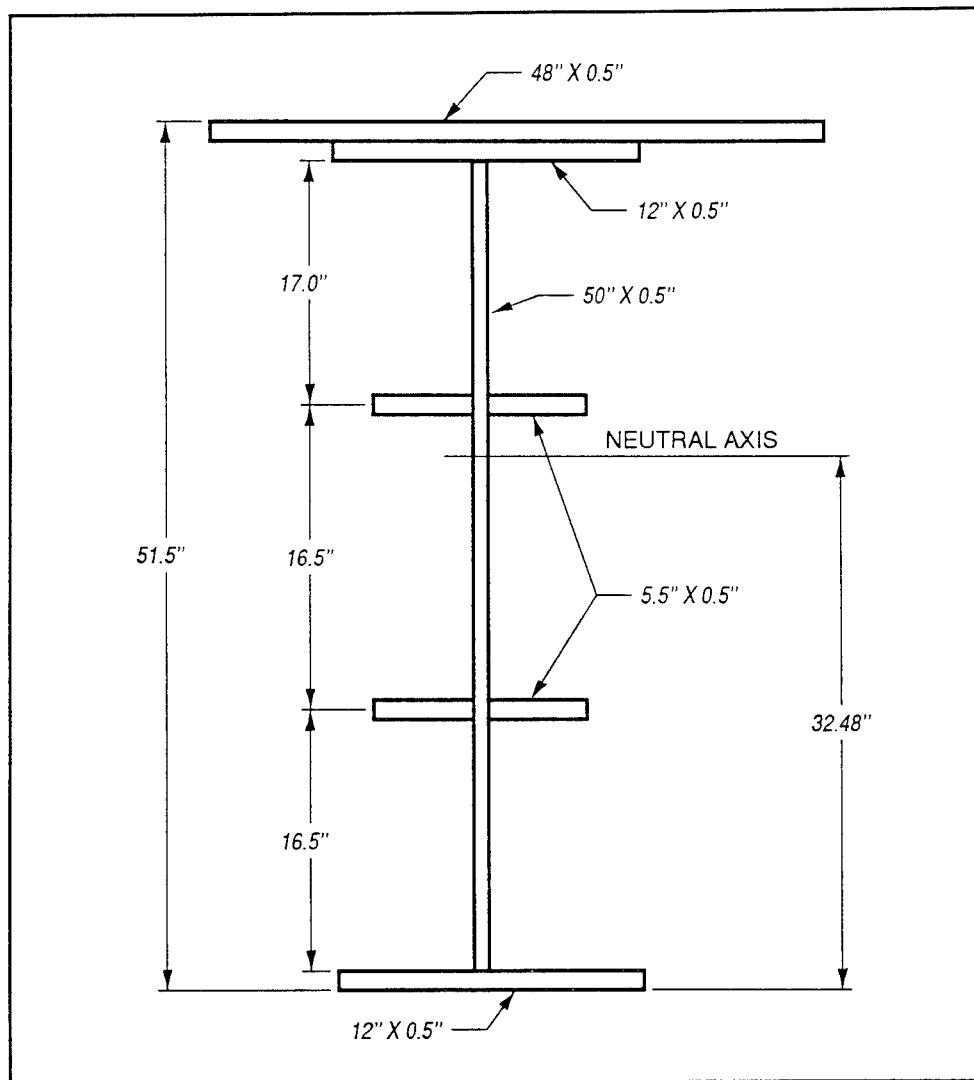

Figure 26. Girder cross section

and twist of the cross section by intermediate diaphragms every 120 in. Transverse stiffeners are not required in this section.

- a. *Width-to-thickness ratios.* For this example, the section is proportioned with the following width-to-thickness ratios to satisfy the noncompact section requirements:

For girder flanges (Table 1),

$$\lambda_r \leq \frac{106}{\sqrt{F_y - 16.5}} = \frac{106}{4.42} = 24 \quad (80)$$

Girder webs should be proportioned using requirements of uniformly compressed stiffened elements (Table 1 and AISC 1986).

$$\lambda_r \leq \frac{253}{\sqrt{F_y}} = \frac{253}{6} = 42.2 \quad (81)$$

- b. *Design loading.* For this girder, the controlling load combination is given by Equation 7. Based on Equation 7, the factored distributed load is equal to 11.372 kips/ft or 0.948 kips/in. (W in Figure 9). This loading produces an axial compressive resultant load equal to 867.0 kips (P_1+P_2 on Figure 9), and a moment at center span equal to 1372.7 kip-ft, thus producing compression in the upstream flange and a moment at the end diaphragm equal to $M_n = 900.4$ kip-ft. The maximum shear load is equal to 274.2 kips (N on Figure 9).

- c. *Cross-section properties.* The section is composed of 12- by 0.5-in. downstream and upstream flanges and a 50- by 0.5-in. web with 5.5- by 0.5-in. longitudinal stiffeners located as shown in Figure 26. The effective width of the skin plate adjacent to each edge of the upstream girder flange is based on a $\frac{106}{\sqrt{F_y - 16.5}}$ width-to-thickness

ratio as needed to satisfy noncompact section requirements. The girder has the following properties:

$$I_x = 22,329.4 \text{ in.}^4$$

$$r_x = 18.387 \text{ in.}$$

$$r_y = 5.785 \text{ in.}$$

$$S_{x1} = 1,173.97 \text{ in.}^3$$

$$S_{x2} = 687.47 \text{ in.}^3$$

$$Z_x = 1,058.02 \text{ in.}^3$$

$$y_c = 19.02 \text{ in.}$$

$$A_g = 66.0 \text{ in.}^2$$

- d. *Noncompact section check.* The following calculations show that the section is noncompact. With two lines of longitudinal stiffeners located as shown in Figure 26, the maximum clear distance of the web is $d = 17.0$ in. The width-to-thickness ratio for the web is

$$\lambda = \frac{d}{t} = \frac{17.0}{0.5} = 34.0 \quad (82)$$

which is less than λ_r of Table 1. Therefore, the web is compact. For the upstream flange, the width-to-thickness ratio including the skin plate is

$$\lambda = \frac{b}{2t} = \frac{12}{2(1.0)} = 6.0 < \lambda_p \quad (83)$$

which is less than λ_p of Table 1. Therefore, the upstream flange is compact. For the downstream flange, the width-to thickness ratio is

$$\lambda = \frac{b}{2t} = \frac{12}{2(0.5)} = 12.0 \quad (84)$$

which is bigger than λ_p and less than λ_r of Table 1. Therefore, the downstream flange is noncompact. Since the plate girder section requires just one noncompact element to be noncompact, the plate girder section is noncompact.

- e. *Web shear.* The girder web will be checked for the maximum shear $V_u = 274.4$ kips (see Chapter 2, Equations 42 through 45, for design criteria), for

$$\frac{h}{t_w} < \frac{187}{\sqrt{\frac{k}{F_{yw}}}}, V_n = 0.6F_{yw}A_w \quad (85)$$

where

$$K = 5 + \frac{5}{\left(\frac{a}{h}\right)^2} \quad (86)$$

unless a/h exceeds 3.0 or $[260/(h/t_w)]^2$, in which case $K = 5$. With $a = 120$ in. (intermediate diaphragm spacing) and $h = 17.0$ in. (web maximum clear depth):

$$\frac{a}{h} = \frac{120}{17.0} = 7.05 > 3 ; K = 5 \quad (87)$$

$$\frac{h}{t_w} = \frac{17.0}{0.5} = 34.0 < 187 \sqrt{\frac{5}{36}} = 69.7 \quad (88)$$

$$V_n = 0.6(36)(25) = 540 \text{ kips} \quad (89)$$

$$\alpha\phi V_n = (0.9)(0.9)(540) = 437.4 \text{ kips} \quad (90)$$

which is greater than $V_u = 274.2$ kips. Therefore, the section is acceptable for shear.

f. *Combined forces.* The horizontal girder is considered a singly symmetrical prismatic member subjected to axial force and flexure about its major axis (see Chapter 2 for design criteria).

(1) Determine axial strength (Equations 15 through 17).

- Slenderness ratios

$$\frac{Kl_x}{r_x} = \frac{1.0(579)}{18.39} = 31.50 \text{ controls} \quad (91)$$

$$\frac{Kl_y}{r_y} = \frac{0.65(120)}{5.79} = 13.47 \quad (92)$$

- Calculate the critical stress F_{cr} ,

$$\lambda_c = \frac{Kl}{r\pi} \sqrt{\frac{F_y}{E}} = \frac{31.5}{\pi} \sqrt{\frac{36}{29000}} = 0.353 \quad (93)$$

$$F_{cr} = (0.658^{\lambda_c^2}) F_y = (0.658^{0.125}) 36.0 = 34.17 \text{ kips} \quad (94)$$

- Calculate the axial strength

$$P_n = A_g F_{cr} \quad (95)$$

$$P_n = (66.0) 34.17 = 2,255.07 \text{ kips} \quad (96)$$

$$\alpha\phi P_n = (0.9)(0.85) 2,255.05 = 1,725.11 \text{ kips} \quad (97)$$

which is greater than $P_u = 867.0$ kips. Therefore, the section is acceptable for compression load.

(2) Determine whether Equation 38 or 39 should be used in members subject to bending and axial force for center line section with $P_u = 867.13$ kips, $\phi_c = 0.85$, and $\alpha = 0.9$:

$$\frac{P_u}{\alpha\phi_c P_n} = \frac{867.13}{(0.9)(0.85) 2,255.07} = 0.503 \quad (98)$$

which is bigger than 0.2. Therefore, Equation 38 should be used.

$$\frac{P_u}{\phi_c P_n} + \frac{8}{9} \left(\frac{M_{ux}}{\phi_b M_{nx}} + \frac{M_{uy}}{\phi_b M_{ny}} \right) < 1.0 \quad (99)$$

$$M_{uy} = 0 \quad (100)$$

- (3) Determine the moment magnifier to be used in Equations 40 and 41

$$B_1 = \frac{C_m}{\left(1 - \frac{P_u}{P_e} \right)} \geq 1.0 \quad (101)$$

$$P_e = \frac{A_g F_y}{\lambda_c^2} = \frac{(66.0)(36)}{0.125^2} = 1,9037.97 \quad (102)$$

substituting the values above with $C_m = 1.0$ in Equation 40, the moment magnifier is

$$B_1 = \frac{1.0}{\left(1.0 - \frac{867.1}{19,037.97} \right)} = 1.05 \quad (103)$$

- (4) Determine the maximum acting moment at girder center line:

$$M_{ux} = B_1 M_{nt} + B_2 M_u \quad (104)$$

$$M_u = 0 \quad (105)$$

$$M_{ux_{CL}} = B_1 M_{nt} = 1.05(19,471.9) = 17,295.49 \text{ kip-in.} \quad (106)$$

- (5) Determine flexure strength, center line section. For a noncompact section with the compression flange fully laterally supported (center line section), the flexure strength is the plastic moment (Equation 18).

$$M_n = M_p = F_y Z = (36)(1,058.02) = 38,088.72 \text{ kip-in.} \quad (107)$$

$$\alpha\phi M_n = (0.9)(0.9) 38,088.72 = 30,851.86 \text{ kip-in.} \quad (108)$$

which is greater than $M_{uxCL} = 17,295.49$ kip-in. Therefore, the section is acceptable for bending.

- (6) Determine if the section is acceptable for combining loads (axial and flexure) by substituting the values above into Equation 38:

$$0.51 + \frac{8}{9} \left[\frac{17,295.49}{(0.9)(0.9)(38,088.72)} \right] = 1.00 \quad (109)$$

Since the value is 1.0, the center line section is acceptable.

- (7) Determine flexure strength, end diaphragm section. For noncompact sections with the beam compression flange laterally supported each 120 in., the moment strength is calculated using criteria in Chapter 2 and Equations 18 through 37. For this example, the flange local buckling is controlling,

$$\lambda_p < \lambda \leq \lambda_r \quad (110)$$

and the acting moment at the end diaphragm is,

$$M_{uxED} = B_1 M_{nt} = 1.05(10,804.8) = 11,345.04 \text{ kips-in.} \quad (111)$$

Using Equation 20, the moment strength is,

$$M_n = M_p - (M_p - M_r) \left(\frac{\lambda - \lambda_p}{\lambda_r - \lambda_p} \right) \quad (112)$$

$$M_n = 38,088.72 - (38,088.72 - 13,404.0) \left(\frac{12.0 - 10.8333}{24.0043 - 10.8333} \right) = 2,991.8 \quad (113)$$

$$M_n = 2,991.8 \text{ kip-ft} \quad (114)$$

$$\phi \alpha M_n = (0.9)(0.9)2,991.8 = 2,423.4 \text{ kip-ft} \quad (115)$$

which is greater than $M_{uxED} = 11,345.04$ kips-in. Therefore, the section at the end diaphragm is acceptable for bending. Substituting the values above into Equation 38 to determine if the end diaphragm section is acceptable for combining loads (axial and flexure),

$$0.503 + \frac{8}{9} \left(\frac{11,345.04}{29,080.8} \right) = 0.85 < 1.0 \quad (116)$$

Since this value is less than 1.0, the section at the end diaphragm is acceptable. At the midspan and end diaphragm locations, the chosen section is adequate for combined forces. The cross section consists of the following elements:

Upstream flange	12.0 by 0.5 in.
Downstream flange	12.0 by 0.5 in.
Skin plate	0.5 in.
Web	50.0 by 0.5 in.
Two longitudinal stiffeners	5.5 by 0.5 in.

End diaphragm

For this example, the end diaphragm is designed using the critical load combination in Panels 7 through 11. The end diaphragm is designed as a fixed plate (skin plate criteria) with the following dimensions (see Figure 27 for details):

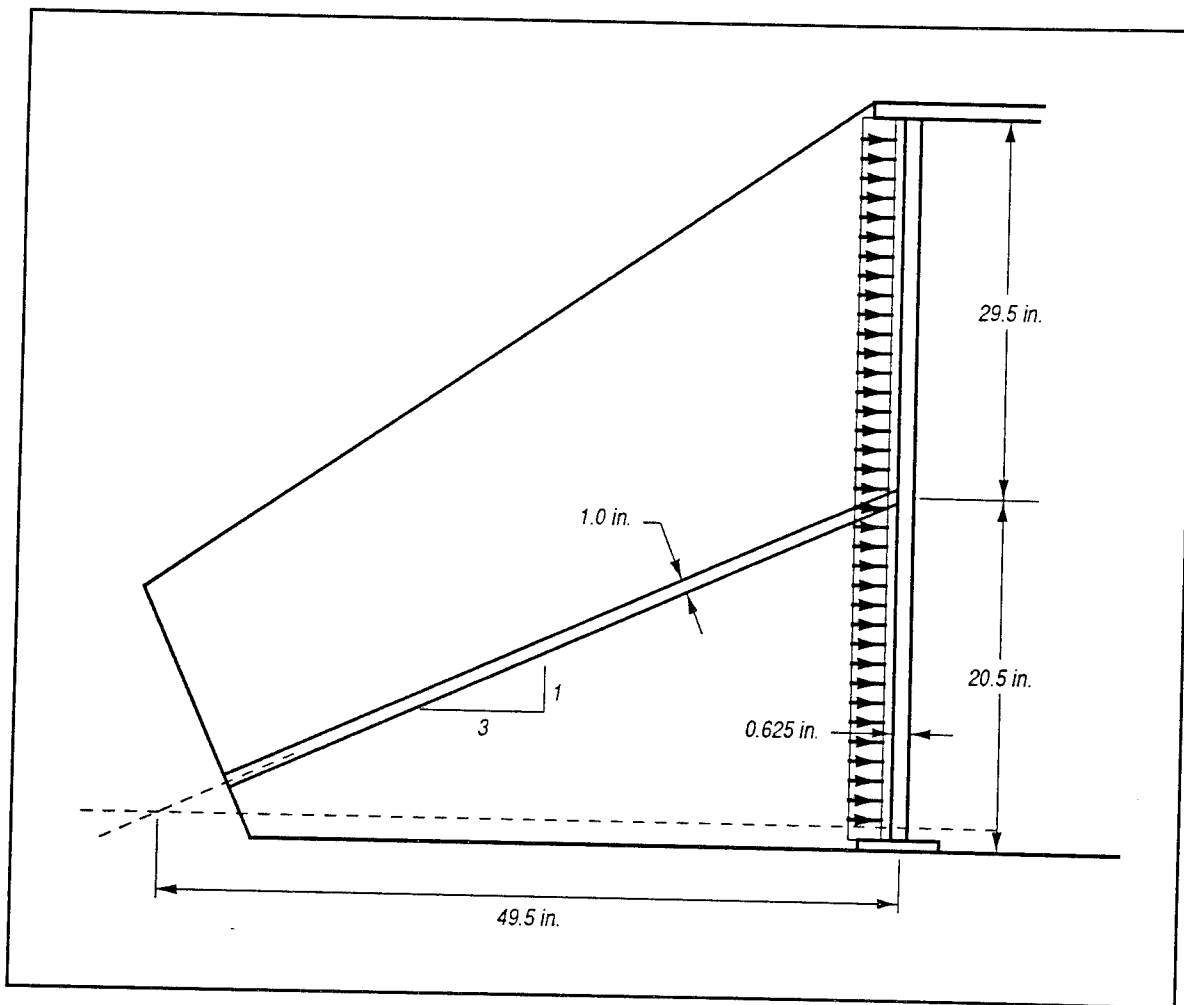

Figure 27. End diaphragm section

$$a = 48 \text{ in.}$$

$$b_1 = 29.5 \text{ in.}$$

$$b_2 = 20.5 \text{ in.}$$

$$W_u = 2.787 \text{ kips/ft}^2 = 0.0194 \text{ ksi}$$

$$W = 1.935 \text{ kips/ft}^2 = 0.0134 \text{ ksi}$$

$$F_y = 36.0 \text{ ksi}$$

$$F_r = 21 \text{ ksi; load condition 2, category C}$$

$$\alpha = 0.9$$

$$\phi = 0.9$$

- a. *Required thickness based on yield limit state.* Equation 12 should be used to determine the end diaphragm thickness with $F = \alpha\phi F_y$, $W = W_u$, $\alpha = 0.9$, and $\phi = 0.9$:

$$t_{\min} = \sqrt{\frac{0.9(0.0194)(29.5)^2}{29.16 \left[1 + 0.623 \left(\frac{29.5}{48} \right)^6 \right]}} = 0.529 \text{ in.} \quad (117)$$

Use 0.625 in. Stress acting with $t = 0.625$ in.

$$\sigma = \frac{0.5 W_u b^2}{\phi \alpha t^2 \left[1 + 0.623 \left(\frac{b}{a} \right)^6 \right]} \quad (118)$$

$$\sigma = \frac{(0.5)(0.0194)29.5^2}{(0.9)(0.9)(0.625)^2 \left[1 + 0.623 \left(\frac{29.5}{48} \right)^6 \right]} = 25.8 \text{ ksi} \quad (119)$$

which is less than $F_y = 36.0$. Therefore, an end diaphragm plate thickness of 0.625 in. is acceptable for yield limit state.

- b. *Deflection check.* Equation 11 should be used to calculate the deflection with $t = 0.625$ in. and $\delta_{all} = 0.4t$,

$$\delta = \frac{0.0284(0.0134)(29.5)^4}{\left[1 + 1.056 \left(\frac{29.5}{48} \right)^5 \right] (29,000)(0.0625)^3} = 0.0373 \text{ in.} \quad (120)$$

which is less than $\delta_{all} = 0.4t = 0.25$ in. Therefore, an end diaphragm plate thickness of 0.625 in. is acceptable for deflection criteria.

- c. *Minimum thickness required by fatigue.* Equation 12 should be used to calculate the thickness required by fatigue with $F = F_r$, $W = W$ (AISC 1986)

$$t_{fat} = \sqrt{\frac{0.5(0.0134)(29.5)^2}{21 \left[1 + 0.623 \left(\frac{29.5}{48} \right)^6 \right]}} = 0.511 \text{ in.} \quad (121)$$

The minimum thickness required by fatigue is 0.511 in.; use $t = 0.625$ in. (check with program to verify). Fatigue stress range using $t = 0.625$ is,

$$\sigma = \frac{(0.5)(0.0134)29.5^2}{(0.625)^2 \left[1 + 0.623 \left(\frac{29.5}{48} \right)^6 \right]} = 14.46 \text{ ksi} \quad (122)$$

which is less than $F_r = 21.0$ ksi. Therefore, the end diaphragm plate thickness of 0.625 in. is acceptable for fatigue criteria. Since the end diaphragm with a thickness of 0.625 in. is acceptable for yield limit state, deflection, and fatigue, the end diaphragm with a thickness of 0.625 in. is acceptable.

Quoin post

The quoin post will be designed using load combination 3 (Equation 8) with $H_f = 0.0$. For dimensions of the quoin post shown in Figure 28, and the properties are as follow:

$$A = 103.52 \text{ in.}^2$$

$$C_x = 23.89 \text{ in.}$$

$$C_y = 1.39 \text{ in.}$$

$$I_x = 6,176.09 \text{ in.}^4$$

$$I_y = 14,691.10 \text{ in.}^4$$

$$X_{pin} = 27.27 \text{ in.}$$

$$Y_{pin} = 6.71 \text{ in.}$$

$$e_x = 3.38 \text{ in.}$$

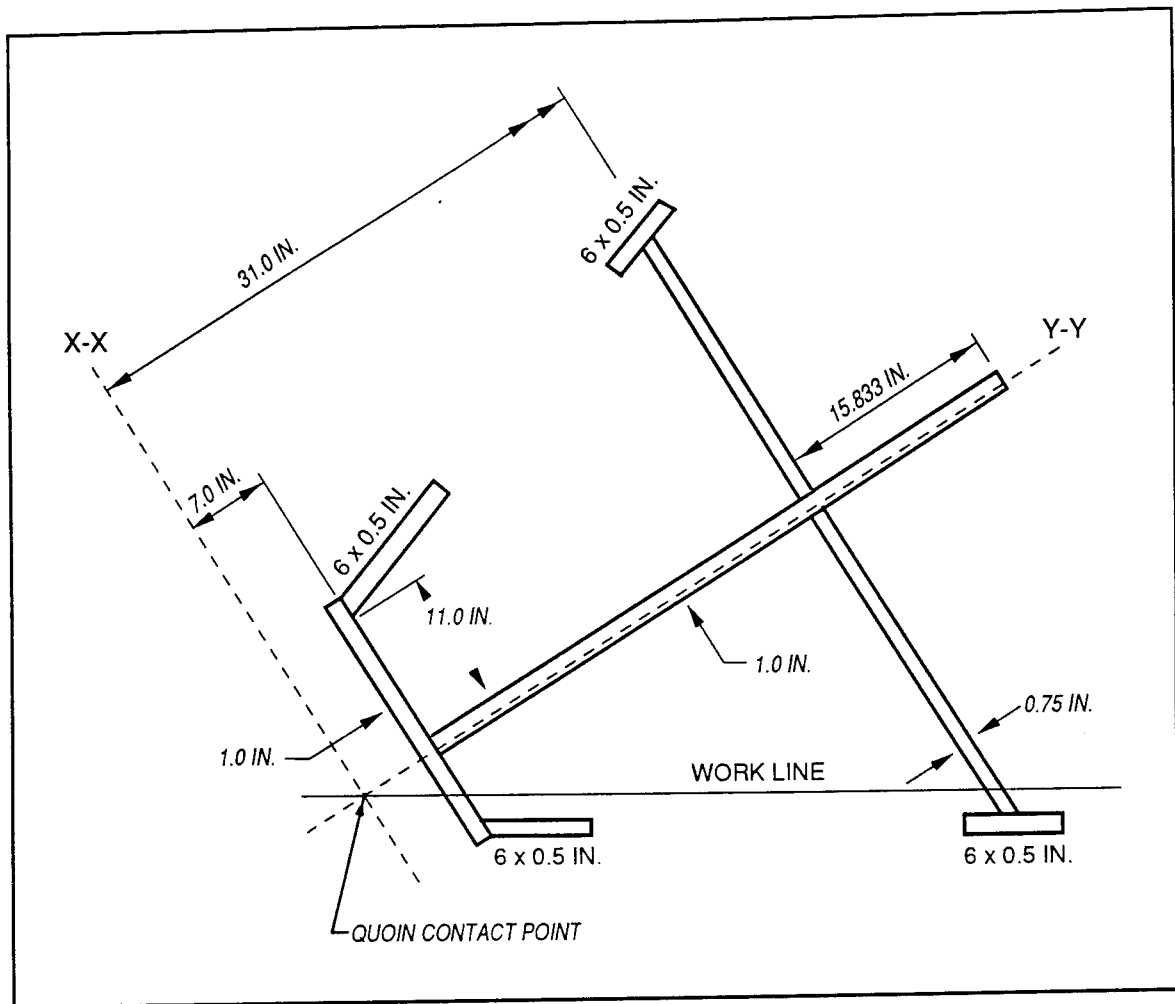

Figure 28. Quoin post section

$$e_y = 5.32 \text{ in.}$$

$$W_{gate} = 220.14 \text{ kips}$$

$$C+M = 185.00 \text{ kips}$$

$$P_u = 1.2 W_{gate} + 1.6 (C+M)$$

$$P_u = 560.17 \text{ kips}$$

$$M_x = P_u(e_y) = 560.17(5.32) = 2,980.1 \text{ kip-in.}$$

$$M_y = P_u(e_x) = 560.17(3.38) = 1,893.4 \text{ kip-in.}$$

The stresses acting in the quoin post should be determined in Points A through F, which are the most critical points (Figure 15), using the following equation:

$$\sigma = \frac{P}{\alpha\phi A} + \frac{M_x}{\alpha\phi I_x} y + \frac{M_y}{\alpha\phi I_y} x \quad (123)$$

where

$$x_a = -17.887 \text{ in.}$$

$$y_a = 10.140 \text{ in.}$$

$$x_b = -17.887 \text{ in.}$$

$$y_b = -8.464 \text{ in.}$$

$$x_c = 9.958 \text{ in.}$$

$$y_c = 19.131 \text{ in.}$$

$$x_d = 9.959 \text{ in.}$$

$$y_d = -17.412 \text{ in.}$$

$$x_e = -16.887 \text{ in.}$$

$$y_e = -0.887 \text{ in.}$$

$$x_f = -5.137 \text{ in.}$$

$$y_f = -0.887 \text{ in.}$$

where the subscripts a through f correspond to the points in Figure 15. Substituting the values above in the stress equation, the stresses are:

$$\begin{aligned} \sigma_p &= \frac{560.2}{(0.9)(0.85) 103.5} + \frac{2,980.1}{(0.9)(0.9) 6,176.09} (y_p) \\ &\quad + \frac{1,893.4}{(0.9)(0.9) 14,691.1} (x_p) \end{aligned} \quad (124)$$

$$\sigma_p = 7.05 + 0.596y_p + 0.159x_p \quad (125)$$

$$\sigma_a = 10.23 \text{ ksi}$$

$$\sigma_b = -0.88 \text{ ksi}$$

$$\sigma_c = 20.04 \text{ ksi}$$

$$\sigma_d = -1.78 \text{ ksi}$$

$$\sigma_e = 3.80 \text{ ksi}$$

$$\sigma_f = 5.68 \text{ ksi}$$

where all the stresses are less than $F_y = 36.0$ ksi. Therefore, the quoin post is acceptable.

Thrust diaphragm

This example will design the thrust diaphragm for Panels 7 through 11 using the criteria in Chapter 2 (see Figure 29 for details).

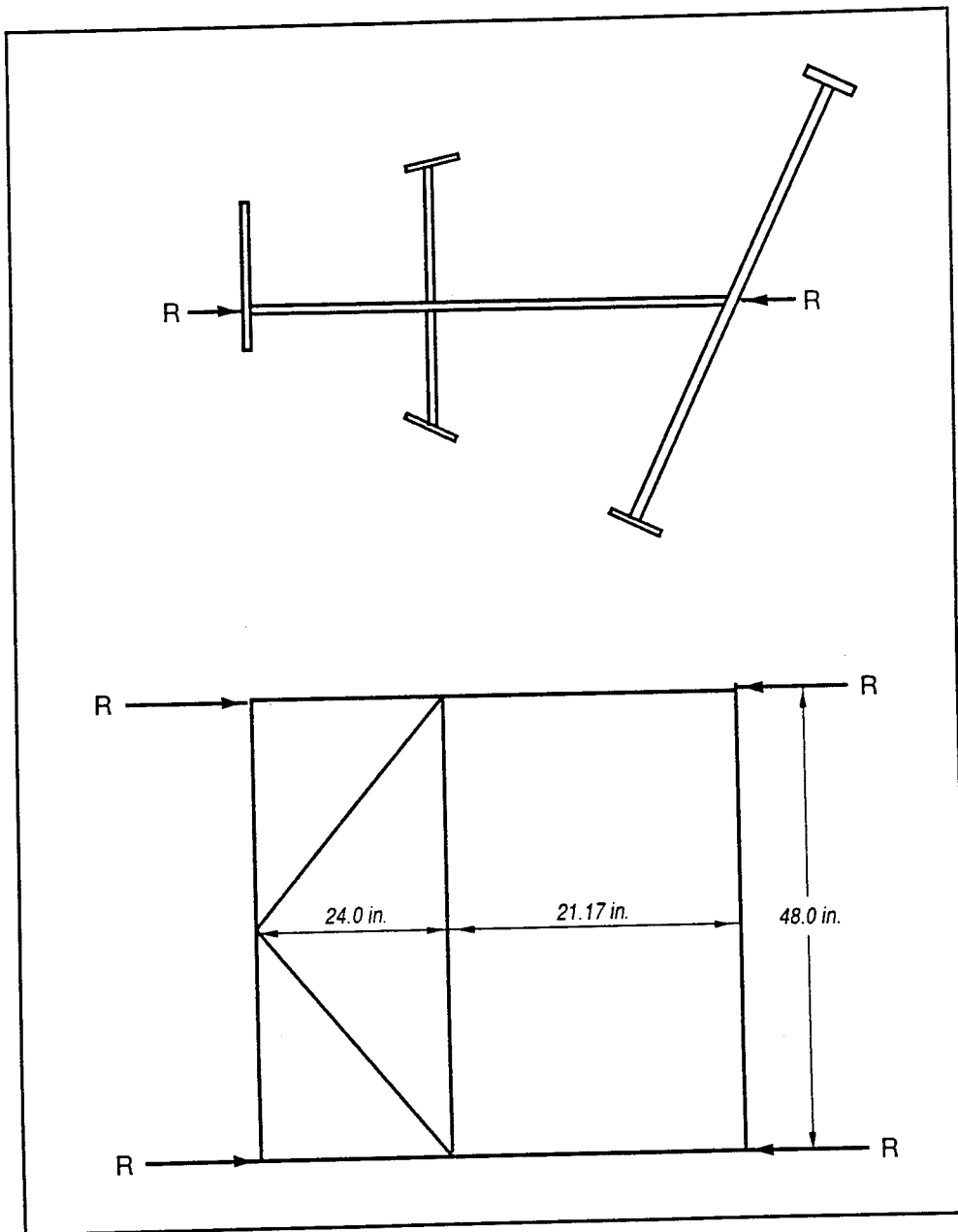

Figure 29. Thrust diaphragm section

- a. *Axial load.* Determine the axial load using Equations 52, 53, and 54. A detailed explanation to determine the axial load acting in the thrust diaphragm is included in Chapter 2 (see Figure 14 for details).

$$W_u = 11.15 \text{ kips/ft}$$

$$L = 48.25 \text{ ft}$$

$$\theta = 18.43 \text{ deg}$$

$$V_a = W_u L \cos \theta = (11.15)(48.25) \cos (18.43) \quad (126)$$

$$= 509.1 \text{ kips}$$

$$V = L \sin \theta = 15.26 \text{ ft} \quad (127)$$

$$H = L \cos \theta = 45.77 \text{ ft}$$

$$\sum M_{cp} = 0.0 \quad (128)$$

where M_{cp} = moment contact point

$$V_a(H) - H_a(V) - \frac{W_u L^2}{2} = 0.0 \quad (129)$$

$$H_a = 678.8 \text{ kips} \quad (130)$$

$$R = V_a \sin(2\theta) + H_a \cos(2\theta) = 848.5 \text{ kips} \quad (131)$$

- b. *Bending stress.* The bending action of the internal and external panels of the thrust diaphragm are calculated using the skin plate equations. The dimensions of the panel are as follows:

$$a = 48 \text{ in.}$$

$$b_{int} = 21.17 \text{ in.}$$

$$b_{ext} = 24.00 \text{ in.}$$

$$q_{int} = 0.44$$

$$q_{ext} = 0.50$$

$$t = 1.0 \text{ in.}$$

$$Area = 1.0(48) = 48.0 \text{ in.}^2$$

$$\alpha = 0.9$$

$$\phi_a = 0.85$$

$$\phi_b = 0.9$$

$$W_u = 2.787 \text{ kips/ft}^2 = 0.01935 \text{ ksi for load combination 2.}$$

$$W = 1.935 \text{ kips/ft}^2 = 0.01344 \text{ kips/in.}^2$$

c. *Yield limit state.*

$$\sigma = \frac{R}{\alpha\phi A} + \frac{0.5 W_u b^2}{\alpha\phi t^2 [1 + 0.623 (q^6)]} \quad (132)$$

$$\sigma = 29.9 \text{ ksi}$$

which is less than $F_n = F_y = 36.0$ ksi. Therefore, the thrust diaphragm section is acceptable for yield limit state.

d. *Deflection.*

$$\delta = \frac{0.0284 W b^2}{[1 + 1.056(q^5)] E t^3} \quad (133)$$

$$\delta = \frac{0.0284 (0.01344) (24^2)}{[1 + 1.056(0.5^5)] 29,000 (1)^3} = 0.00422 \text{ in.} \quad (134)$$

which is less than $\delta_{all} = 0.4t = 0.4$ in. Therefore, the thrust diaphragm section for deflection criteria is acceptable.

e. *Fatigue.* With $F_r = 21.0$ ksi, load condition 2, category C,

$$\sigma_f = \frac{R}{A} + \frac{0.5 W b^2}{t^2 [1 + 0.623(q^6)]} \quad (135)$$

$$\sigma_f = \frac{590.6}{48.0} + \frac{0.5(0.0134)(24^2)}{(1.0^2) [1 + 0.623(0.5^6)]} = 16.13 \text{ kips/in.}^2$$

which is less than $F_r = 21.0$ ksi. Therefore, the thrust diaphragm section is acceptable for fatigue criteria. Because the thrust diaphragm section is acceptable for yield-limit state, deflection, and fatigue, it is totally acceptable.

Tapered end section

The tapered end section is designed for girder 6, where the highest uniform load is located. The criteria to design this element are explained in Chapter 2 (Figure 11). See Figure 30 for geometric details.

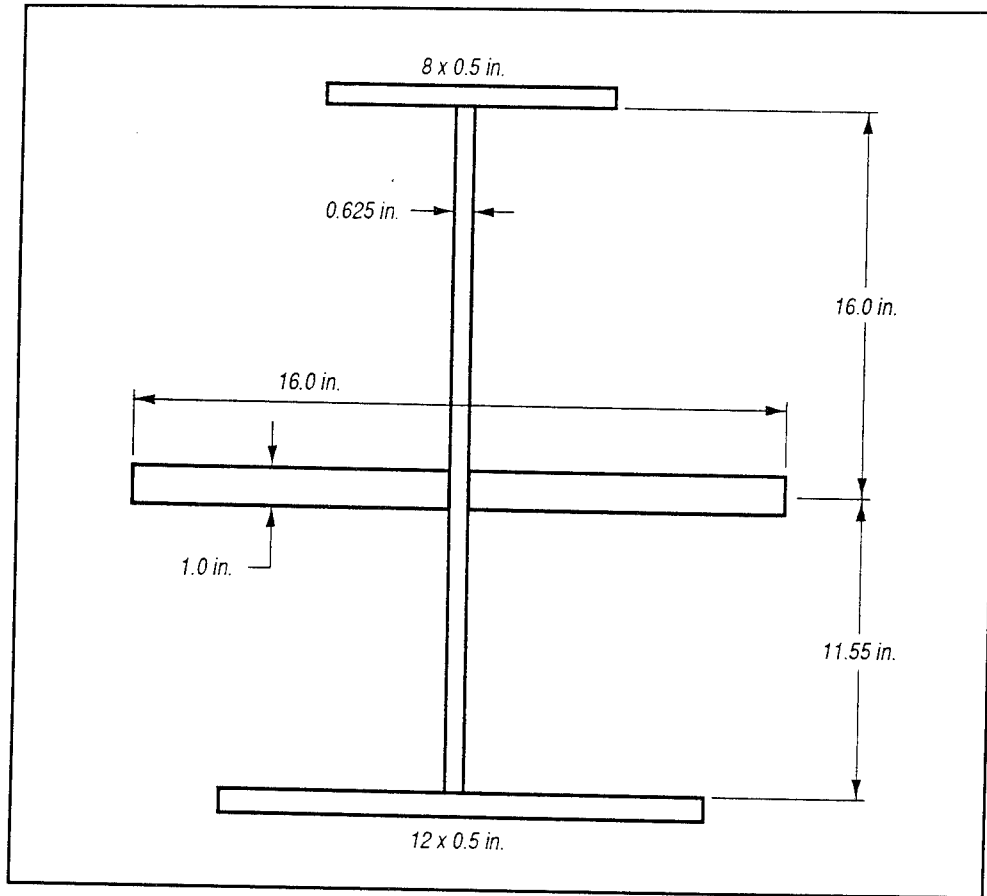

Figure 30. Tapered end section

For girder 6, the smaller span between adjacent girders is 5.0 ft, the thrust diaphragm thickness is 1.0 in., and critical section position $Z' = 22.0$ in. (Figure 11).

The section properties at critical position are (see Figure 30):

$$A = 42.59 \text{ in.}^2$$

$$Y_{bot} = 12.81 \text{ in.}$$

$$Y_{top} = 15.74 \text{ in.}$$

$$I_x = 3,048.90 \text{ in.}^4$$

$$W_u = 11.37 \text{ kips}$$

$$R = 867.42 \text{ kips}$$

Stresses acting in the tapered end section are as follows:

$$\sigma = \frac{P}{\alpha\phi A} + \frac{R(Y_{bot} - Y_{thrust})C}{\alpha\phi I_x} + \frac{W_u Z^2 C}{2\alpha\phi I_x} \quad (136)$$

$$\sigma_{bot} = 31.09 \text{ ksi}$$

$$\sigma_{top} = 20.76 \text{ ksi}$$

which are less than $F_y = 36.0$ ksi. Therefore, the tapered end section is acceptable.

Diagonals

This example pertains to design of the miter gate diagonal members utilizing ASTM A60 steel. Chapter 2 and AISC (1986) provide the general guidance for diagonal design. Diagonal design will be controlled by Equation 8 or 9. Equation 8 represents the case in which the gate is subjected to temporal hydraulic loading. Equation 9 represents the case in which a submerged obstruction constrains the gate leaf motion while the maximum operating force $Q1$ is applied. Plan and elevation views for the gate leaf are shown in Figure 31. The length of each diagonal is 723.7 in. The unfactored loads, the distance from the pintle to the applied loads z , the moment arm of the applied load with respect to the center of moments (located at the operating strut elevation), and corresponding load torque areas Tz for this case are shown in Table 10. For loads $Q1$, H_p , and H_d , a positive value of Tz indicates the case of gate opening and a negative value indicates the case of gate closing.

The factored loads for Equations 8 and 9 are as follows:

$$Tz(D) = 1.2(-14,273.8) = -17,128.6 \text{ kip-ft}^2$$

$$Tz(C+M) = 1.6(-14,383.1) = -23,012.9 \text{ kip-ft}^2$$

$$Tz(Q) = 1.2(+279,352.0) = +335,222.4 \text{ kip-ft}^2$$

$$Tz(H_t) = 1.0(+136,277.9) = +136,277.9 \text{ kip-ft}^2$$

The design strength for tension members is the lower of the following:

Case a. For yielding in the cross section, $\alpha = 0.9$, $\phi_t = 0.9$

$$P_n = F_y A_g$$

$$\alpha \phi_t F_y = 0.9(0.9)(60) = 48.6 \text{ ksi}$$

Case b. For fracture in the net section, $\alpha = 0.9$, $\phi_t = 0.75$

$$P_n = F_u A_e = F_u (U A_g)$$

The end connections are welded to gusset plates with a total weld length greater than two times the bar width. Therefore, $U = 1.0$ and the effective area is the same as the gross area A_g (AISC 1986).

$$\alpha \phi_t F_u = 0.9(0.75)(75.0) = 50.63 \text{ ksi}$$

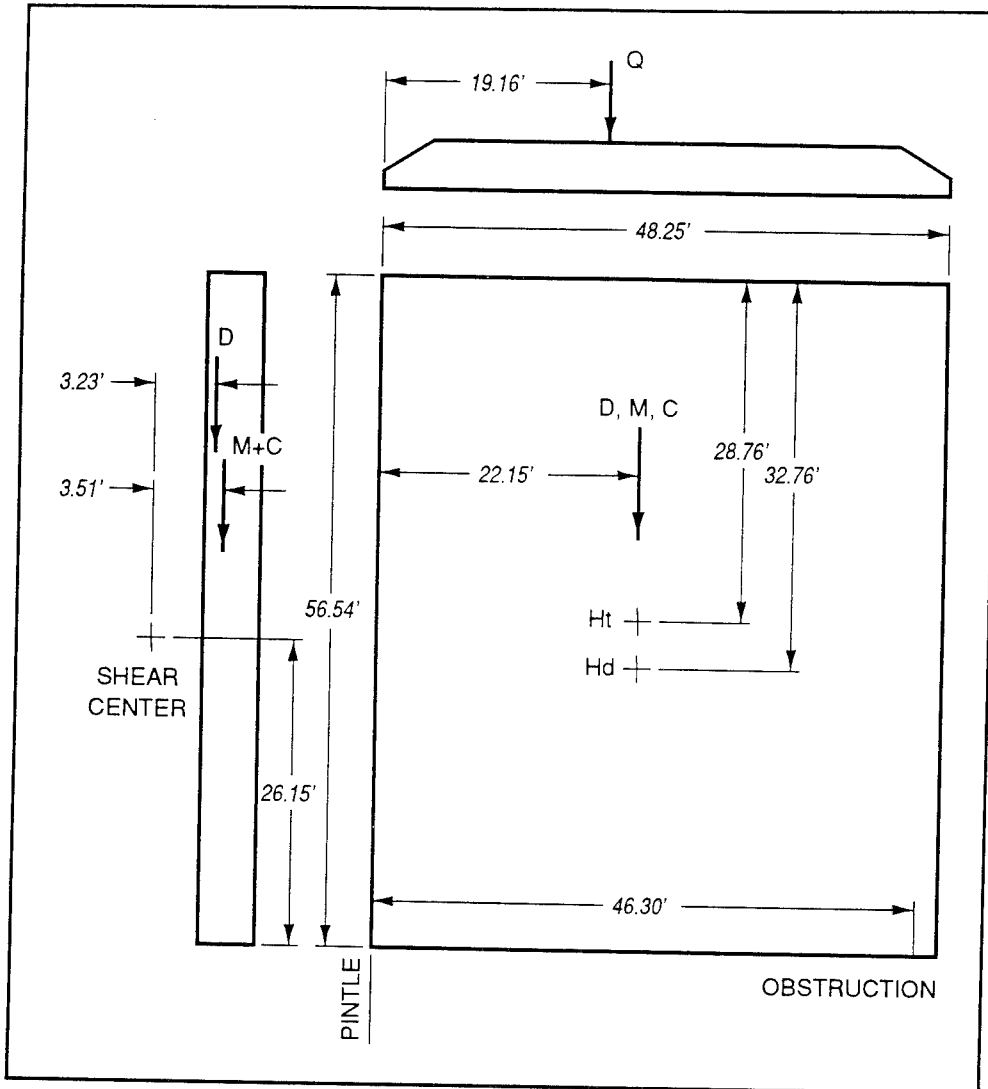

Figure 31. Plan and elevation views of the gate, diagonals

Load	Force, kips	Moment Arm, ft	z, ft	Tz, kip-ft ²
D	199.51	3.23	22.15	-14,273.8
C + M	185.0	3.51	22.15	-14,383.1
Q _t	106.0	56.92	46.30	±279,352
H _t	214.0	28.75	22.15	±136,278
H _d	70.93	32.75	22.15	±52,266.5

Case *a* controls and the limiting tensile stress is 48.6 ksi. Following the procedure in Chapter 2 used to obtain the diagonals' size, the following is obtained:

- a. The stiffness of the leaf in deform the diagonal A' , is the sum of the average cross-sectional areas of the two vertical and horizontal girders which bound the panels times $1/8$.

$$A' = 19.06 \text{ in.}^2$$

- b. The ratio of change in length R_o of diagonal to leaf deflection is calculated using Equation 61.

$$R_o = +0.123$$

- c. The required size of the diagonals is calculated using Equation 62. Substituting values above into Equation 62:

$$A_p = \frac{\Sigma Tz}{sR_o hv} = - \frac{-375,363.9}{(48.6)(0.123)(55.0)(46.3)} \quad (137)$$

$$= 24.7 \text{ in.}^2$$

$$A_n = - \frac{\Sigma Tz}{sR_o hv} = - \frac{-335,224.4}{(48.6)(0.123)(55.0)(46.3)} \quad (138)$$

$$= 22.0 \text{ in.}^2$$

$$\text{Use } A_p = 26.0 \text{ in.}^2 \text{ and } A_n = 24.0 \text{ in.}^2$$

- d. The ratio R of the actual change in length of diagonals to deflection of the leaf is calculated using Equation 63 as follows:

$$R_p = \frac{A'}{A + A'} R_o = \left(\frac{19.06}{26.0 + 19.06} \right) (0.123) \quad (139)$$

$$= 0.0520$$

$$R_n = \frac{A'}{A + A'} R_o = \left(\frac{19.06}{24.0 + 19.06} \right) (0.123) \quad (140)$$

$$= 0.0544$$

e. Equation 64 is used to calculate the elasticity constant of a diagonal, which is:

$$Q_p = 204,098.33 \text{ kip-ft}$$

$$Q_n = 197,248.3 \text{ kip-ft}$$

f. The elasticity constant of the leaf without diagonals is calculated using Equation 58 as follows:

$$Q_o = 4E_s \sum \left(\frac{J}{H} + \frac{J}{v} \right) = \frac{4}{(1,000)(12)} (10E + 06) \left(\frac{302.6}{660.0} + \frac{180.9}{555.6} \right) = 1,045.5 \text{ kip-ft} \quad (141)$$

g. For deflection of leaf, use Equation 65 to calculate the live-load gate-opening deflection (critical case is when $C + M = 0$),

$$\Delta_o = \frac{\Sigma Tz(Q)}{Q_o + \Sigma Q} = \frac{335,222.4}{402,292.1} 12.0 = 9.99 \text{ in.} \quad (142)$$

$$D_{min}^+ = 9.99 \text{ in.}$$

Use Equation 65 to calculate the live-load gate-closing deflection,

$$\begin{aligned} \Delta_o &= \frac{\Sigma [Tz(C + M) - Tz(Q)]}{Q_o + \Sigma Q} \quad (143) \\ &= \frac{-358,235.3}{402,292.1} 12.0 = -10.68 \text{ in.} \end{aligned}$$

$$D_{min}^- = -10.68 \text{ in.}$$

h. Use Equation 66 to calculate the maximum numerical value of D ,

$$D_{max}^- = \frac{sL}{R_n E} + \Delta_n = \frac{48.6(723.7)}{-0.0545(29,000)} \quad (144)$$

$$+ 9.99 = -12.10 \text{ in.}$$

$$D_{max}^+ = \frac{sL}{R_p E} + \Delta_p = \frac{48.6(723.7)}{0.052(29,000)} \quad (145)$$

$$- 10.68 = 12.63 \text{ in.}$$

Use $D_p = 11.43 \text{ in.}$ and $D_n = -10.68 \text{ in.}$

- i. The stress in the diagonals must remain between the tension-limiting stress of 48.6 ksi and the minimum stress of 1.0 ksi (diagonals must always remain in tension). The maximum-tension stress will occur as follows:

For positive diagonals on gate closing (Equation 67),

$$s_p = \frac{R_p E}{L} (D_p - \Delta_c) = \frac{(0.0521)(29,000)}{723.7} \quad (146)$$

$$[11.43 - (-10.68)] = 46.16 \text{ ksi}$$

which is less than 48.5 ksi. Therefore, the positive diagonal is acceptable.

For the negative diagonal on gate opening,

$$s_n = \frac{R_n E}{L} (D_n - \Delta_o) = \frac{(0.0545)(29,000)}{723.7} \quad (147)$$

$$[-10.68 - (-9.99)] = 45.17 \text{ ksi}$$

which is less than 48.6 ksi. Therefore, the negative diagonal is acceptable.

References

- American Institute of Steel Construction. (1986). "Load and Resistance Factor Design Manual of Steel Construction," 1st ed., Chicago, IL.
- _____. (1989). "Allowable Stress Design Manual of Steel Construction," 9th ed., Chicago, IL.
- Elingwood, Bruce. (1993). "Load and resistance factor design for steel miter gates," Instruction Report ITL-93-4, U.S. Army Engineer Waterways Experiment Station, Vicksburg, MS.
- Headquarters, Department of the Army. (1984). "Lock gates and operating equipment," Engineer Manual 1110-2-2703, Washington, D.C.
- _____. (1988). "User's guide for design and investigation of horizontally framed miter gates (CMITER)," Washington, DC.
- _____. (1992). "Design of hydraulic steel structures," Engineer Manual 1110-2-2105, Washington, D.C.
- Timoshenko, Stephen P., and Woinowsky, S. (1959). *Theory of plates and shells*, 2nd ed., McGraw-Hill, New York.

Appendix A Example Problem and Program Results

Recommended Design Module, Output File

REQUIRED INPUT DATA
LOAD AND RESISTANCE FACTOR DESIGN

DATA FILE NAME- exa1.dat
Lock and Dam #3*
Example 1 - Run # 1
May 1993

—— LEAF GEOMETRY (HORIZONTAL) ——

GATE LENGTH = 48.2500 FT
GIRDER WEB DEPTH = 50.0000 IN
MITER SLOPE = 3.000 TO 1
WORKLINE TO DOWNSTREAM FLANGE = .3333 FT
PINTLE TO QUOIN CONTACT (ALONG WORKLINE) = 1.9792FT
PINTLE TO WORKLINE = 1.2500 FT
END DIAPHRAGM TO QUOIN CONTACT = 49.5000 IN
END DIAPHRAGM TO MITER CONTACT = 49.5000 IN

NUMBER OF SPACES FOR DIAPHRAGMS AND INTERCOSTALS
PANEL NOS. 1 TO 11 4 0

—— GATE GEOMETRY (VERTICAL) ——

GIRDER NO	WEB LOCATION (DISTANCE ABOVE SILL)
1	56.0000 FT
2	50.0000 FT
3	44.0000 FT
4	38.0000 FT
5	32.0000 FT
6	26.0000 FT
7	21.0000 FT
8	17.0000 FT
9	13.0000 FT
10	9.0000 FT
11	5.0000 FT
12	1.0000 FT

SILL ELEVATION = 46.0000 FT
 DIST FROM SILL TO TOP OF SKIN PLATE = 56.5417 FT
 DIST FROM SILL TO BOT OF SKIN PLATE = .3333 FT
 BOT GIRDER DS FLANGE DOWNWARD EXTENTION = 3.0000 IN

—— STEEL YIELD STRENGTHS ——

WEB	FLANGE	SKINPLATE	STIFFENERS
36.000 KSI	36.000 KSI	36.000 KSI	36.000 KSI

INTERCOSTALS	QUOIN POST & THRUST DIAPH.	DIAGONALS
36.000 KSI	.000 KSI	.000 KSI

OTHER STEEL
 36.000 KSI

—— GATE LOADING ——

ACTIVE LOAD COMBINATION

- 1: 1.4 Hs + 1.0 I
- 2: 1.4 Hs + 1.0 Hc
- 6: 1.2 Hs + 1.0 E

WATER ELEVATIONS

UPPER POOL = 95.000 FT FULL SUBMERGENCE = 105.500 FT
 LOWER POOL = 64.000 FT OPERATING WATER = 95.000 FT

MINIMUM DESIGN HEAD		TEMPORAL HEAD
SKINPLATE	GIRDERS	1.250 FT
6.000 FT	.000 FT	

MISCELLANEOUS LOADS AND LOCATIONS

	DEAD	LIVE	BUOYANCY
CONCENTRATED LOAD	185000.0 LB	.0 LB	.0 LB
DIST FROM QUOIN CONTACT	24.1500 FT	.0000 FT	.0000 FT
OFFSET FROM DS EDGE WEB	25.5000 IN	.0000 IN	.0000 IN

DESIGN PARAMETERS

OPERATING WATER PRESSURE = 30.000 LB/SQFT
 UNIT WEIGHT OF WATER = 62.428 LB/CUFT
 STRUT FORCE = .0 LB
 OBSTRUCTION LOCATION = 46.3000 FT
 EARTHQUAKE ACCEL. FACTOR = .050

RECOMMENDED GIRDER LOCATIONS TO YIELD
 APPROXIMATE EQUAL LOADS
 LOAD COMBINATION 1

GIRDER NUMBER	ELEVATION	SPACING FT.	LOAD K/F	AXIAL LOAD K
1	102.00		.00	.00
		6.000		
2	96.00		.17	13.38
		6.000		
3	90.00		2.62	200.69
		6.000		
4	84.00		5.77	441.52
		6.000		
5	78.00		8.91	682.34
		6.000		
6	72.00		10.82	828.53
		4.900		
7	67.10		10.89	833.87
		4.100		
8	63.00		10.92	836.14
		4.000		
9	59.00		10.84	829.52
		4.000		
10	55.00		10.84	829.52
		4.000		
11	51.00		10.84	829.52
		4.000		
12	47.00		8.13	622.14

GIRDER LOAD TABLE LOAD COMB.NO. 1

GIRDER NUMBER	ELEVATION	SPACING FT.	LOAD K/F	AXIAL LOAD K
1	102.00		.00	.00
		6.000		
2	96.00		.17	13.38
		6.000		
3	90.00		2.62	200.69
		6.000		
4	84.00		5.77	441.52
		6.000		
5	78.00		8.91	682.35
		6.000		
6	72.00		10.94	837.05
		5.000		
7	67.00		10.91	835.37
		4.000		
8	63.00		10.79	826.18
		4.000		
9	59.00		10.84	829.52
		4.000		
10	55.00		10.84	829.52
		4.000		
11	51.00		10.84	829.52
		4.000		
12	47.00		8.13	622.14

GIRDER LOAD TABLE LOAD COMB.NO. 2

GIRDER NUMBER	ELEVATION	SPACING FT.	LOAD K/F	AXIAL LOAD K
1	102.00		.00	.00
		6.000		
2	96.00		.33	25.33
		6.000		
3	90.00		3.09	236.53
		6.000		
4	84.00		6.24	477.36
		6.000		
5	78.00		9.38	718.18
		6.000		
6	72.00		11.37	869.90
		5.000		
7	67.00		11.27	862.25
		4.000		
8	63.00		11.11	850.07
		4.000		
9	59.00		11.15	853.41
		4.000		
10	55.00		11.15	853.41
		4.000		
11	51.00		11.15	853.41
		4.000		
12	47.00		8.36	640.06

GIRDER LOAD TABLE LOAD COMB.NO. 6

GIRDER NUMBER	ELEVATION	SPACING FT.	LOAD K/F	AXIAL LOAD K
1	102.00		.00	.00
		6.000		
2	96.00		.18	14.13
		6.000		
3	90.00		2.50	191.33
		6.000		
4	84.00		5.32	407.47
		6.000		
5	78.00		8.11	621.02
		6.000		
6	72.00		9.87	755.83
		5.000		
7	67.00		9.81	750.71
		4.000		
8	63.00		9.72	744.27
		4.000		
9	59.00		9.85	754.01
		4.000		
10	55.00		9.91	758.65
		4.000		
11	51.00		9.96	762.62
		4.000		
12	47.00		7.50	574.32

PANEL NUMBER 1

NUMBER OF INTERCOSTALS	SKIN PLATE THICKNESS (IN)	INT. LEG LENGTH (IN)	INT. STEM THICKNESS (IN)	TOTAL WEIGHT PANEL (LBS)
1	.500	4.00	.625	4559.7
2	.500	3.50	.625	4712.8
3	.500	3.50	.500	4784.3
4	.500	3.00	.625	4968.1

PANEL NUMBER 2				
NUMBER	SKIN	INT.	INT.	TOTAL
OF	PLATE	LEG	STEM	WEIGHT
INTERCOSTALS	THICKNESS	LENGTH	THICKNESS	PANEL
	(IN)	(IN)	(IN)	(LBS)
1	.500	4.00	.625	4559.7
2	.500	3.50	.625	4712.8
3	.500	3.50	.500	4784.3
4	.500	3.00	.625	4968.1

PANEL NUMBER 3				
NUMBER	SKIN	INT.	INT.	TOTAL
OF	PLATE	LEG	STEM	WEIGHT
INTERCOSTALS	THICKNESS	LENGTH	THICKNESS	PANEL
	(IN)	(IN)	(IN)	(LBS)
1	.563	5.00	.625	5155.2
2	.500	4.50	.625	4814.9
3	.500	4.00	.625	4968.1
4	.500	3.50	.625	5070.1
5	.500	3.50	.500	5070.1

PANEL NUMBER 4				
NUMBER	SKIN	INT.	INT.	TOTAL
OF	PLATE	LEG	STEM	WEIGHT
INTERCOSTALS	THICKNESS	LENGTH	THICKNESS	PANEL
	(IN)	(IN)	(IN)	(LBS)
1	.688	6.00	.750	6356.4
2	.500	6.00	.625	4968.1
3	.500	5.50	.625	5197.7
4	.500	5.00	.625	5376.4
5	.500	4.50	.625	5504.0

PANEL NUMBER 5				
NUMBER	SKIN	INT.	INT.	TOTAL
OF	PLATE	LEG	STEM	WEIGHT
INTERCOSTALS	THICKNESS	LENGTH	THICKNESS	PANEL
	(IN)	(IN)	(IN)	(LBS)
1	.750	8.00	.625	6941.7
2	.625	6.50	.750	6240.7
3	.500	6.00	.750	5458.1
4	.500	5.50	.625	5478.5
5	.500	5.00	.625	5631.6
6	.500	5.00	.625	5886.8

PANEL NUMBER 6				
NUMBER OF INTERCOSTALS	SKIN PLATE THICKNESS (IN)	INT. LEG LENGTH (IN)	INT. STEM THICKNESS (IN)	TOTAL WEIGHT PANEL (LBS)
1	.813	6.00	.625	6005.9
2	.625	6.00	.625	4934.0
3	.500	5.50	.625	4240.7
4	.500	5.00	.625	4389.6
5	.500	5.00	.625	4602.3
6	.500	4.50	.625	4687.3

PANEL NUMBER 7				
NUMBER OF INTERCOSTALS	SKIN PLATE THICKNESS (IN)	INT. LEG LENGTH (IN)	INT. STEM THICKNESS (IN)	TOTAL WEIGHT PANEL (LBS)
1	.750	4.50	.625	4236.5
2	.563	4.50	.625	3368.8
3	.563	4.50	.625	3521.9
4	.500	4.50	.625	3334.7
5	.500	4.00	.625	3402.8
6	.500	3.50	.625	3436.8
7	.500	3.50	.625	3555.9

PANEL NUMBER 8				
NUMBER OF INTERCOSTALS	SKIN PLATE THICKNESS (IN)	INT. LEG LENGTH (IN)	INT. STEM THICKNESS (IN)	TOTAL WEIGHT PANEL (LBS)
1	.750	4.50	.625	4236.5
2	.625	4.50	.625	3709.0
3	.563	4.50	.625	3521.9
4	.500	4.50	.625	3334.7
5	.500	4.00	.625	3402.8
6	.500	4.00	.500	3375.6
7	.500	3.50	.625	3555.9

PANEL NUMBER 9				
NUMBER OF INTERCOSTALS	SKIN PLATE THICKNESS (IN)	INT. LEG LENGTH (IN)	INT. STEM THICKNESS (IN)	TOTAL WEIGHT PANEL (LBS)
1	.750	4.50	.625	4236.5
2	.625	4.50	.625	3709.0
3	.563	4.50	.625	3521.9
4	.500	4.50	.625	3334.7
5	.500	4.00	.625	3402.8
6	.500	4.00	.500	3375.6
7	.500	3.50	.625	3555.9

PANEL NUMBER 10				
NUMBER OF INTERCOSTALS	SKIN PLATE THICKNESS (IN)	INT. LEG LENGTH (IN)	INT. STEM THICKNESS (IN)	TOTAL WEIGHT PANEL (LBS)
1	.750	4.50	.625	4236.5
2	.625	4.50	.625	3709.0
3	.563	4.50	.625	3521.9
4	.500	4.50	.625	3334.7
5	.500	4.00	.625	3402.8
6	.500	4.00	.500	3375.6
7	.500	3.50	.625	3555.9

PANEL NUMBER 11				
NUMBER OF INTERCOSTALS	SKIN PLATE THICKNESS (IN)	INT. LEG LENGTH (IN)	INT. STEM THICKNESS (IN)	TOTAL WEIGHT PANEL (LBS)
1	.750	4.50	.625	4236.5
2	.625	4.50	.625	3709.0
3	.563	4.50	.625	3521.9
4	.500	4.50	.625	3334.7
5	.500	4.00	.625	3402.8
6	.500	4.00	.500	3375.6
7	.500	3.50	.625	3555.9

LOAD FACTOR DESIGN— NON COMPACT SECTION

GIRDER NUMBER 1

GIRDER WEB DEPTH (IN)	GIRDER WEIGHT (LBS)
38.0	4593.8
42.0	4866.0
46.0	5512.5
50.0	5784.7
54.0	6056.9
58.0	6329.2
62.0	6601.4
66.0	7247.9
70.0	7520.1
74.0	7792.4
78.0	8064.6
82.0	8336.8

GIRDER NUMBER 2

GIRDER WEB DEPTH (IN)	GIRDER WEIGHT (LBS)
38.0	4593.8
42.0	4866.0
46.0	5512.5
50.0	5784.7
54.0	6056.9
58.0	6329.2
62.0	6601.4
66.0	7247.9
70.0	7520.1
74.0	7792.4
78.0	8064.6
82.0	8336.8

GIRDER NUMBER 3

GIRDER WEB DEPTH (IN)	GIRDER WEIGHT (LBS)
38.0	4593.8
42.0	4866.0
46.0	5512.5
50.0	5784.7
54.0	6056.9
58.0	6329.2
62.0	6601.4
66.0	7247.9
70.0	7520.1
74.0	7792.4
78.0	8064.6
82.0	8336.8

GIRDER NUMBER 4

GIRDER WEB DEPTH (IN)	GIRDER WEIGHT (LBS)
38.0	4593.8
42.0	4866.0
46.0	5512.5
50.0	5784.7
54.0	6056.9
58.0	6329.2
62.0	6601.4
66.0	7247.9
70.0	7520.1
74.0	7792.4
78.0	8064.6
82.0	8336.8

GIRDER NUMBER 5

GIRDER WEB DEPTH (IN)	GIRDER WEIGHT (LBS)
38.0	5933.6
42.0	4866.0
46.0	5512.5
50.0	5784.7
54.0	6056.9
58.0	6329.2
62.0	6601.4
66.0	7247.9
70.0	7520.1
74.0	7792.4
78.0	8064.6
82.0	8336.8
86.0	9710.7

GIRDER NUMBER 6

GIRDER WEB DEPTH (IN)	GIRDER WEIGHT (LBS)
38.0	9404.4
42.0	6205.8
46.0	5512.5
50.0	5784.7
54.0	6056.9
58.0	6329.2
62.0	6601.4
66.0	7247.9
70.0	7520.1
74.0	7792.4
78.0	8064.6
82.0	8336.8
86.0	9710.7
90.0	10016.9

GIRDER NUMBER 7

GIRDER WEB DEPTH (IN)	GIRDER WEIGHT (LBS)
38.0	9953.1
42.0	6920.4
46.0	5512.5
50.0	5784.7
54.0	6056.9
58.0	6329.2
62.0	6601.4
66.0	7247.9
70.0	7520.1
74.0	7792.4
78.0	8064.6
82.0	8336.8
86.0	9710.7
90.0	10016.9

GIRDER NUMBER 8

GIRDER WEB DEPTH (IN)	GIRDER WEIGHT (LBS)
38.0	9953.1
42.0	6920.4
46.0	5512.5
50.0	5784.7
54.0	6056.9
58.0	6329.2
62.0	6601.4
66.0	7247.9
70.0	7520.1
74.0	7792.4
78.0	8064.6
82.0	8336.8
86.0	9710.7
90.0	10016.9

GIRDER NUMBER 9

GIRDER WEB DEPTH (IN)	GIRDER WEIGHT (LBS)
38.0	9953.1
42.0	7316.0
46.0	5512.5
50.0	5784.7
54.0	6056.9
58.0	6329.2
62.0	6601.4
66.0	7247.9
70.0	7520.1
74.0	7792.4
78.0	8064.6
82.0	8336.8
86.0	9710.7
90.0	10016.9

GIRDER NUMBER 10

GIRDER WEB DEPTH (IN)	GIRDER WEIGHT (LBS)
38.0	9953.1
42.0	7316.0
46.0	5512.5
50.0	5784.7
54.0	6056.9
58.0	6329.2
62.0	6601.4
66.0	7247.9
70.0	7520.1
74.0	7792.4
78.0	8064.6
82.0	8336.8
86.0	9710.7
90.0	10016.9

GIRDER NUMBER 11

GIRDER WEB DEPTH (IN)	GIRDER WEIGHT (LBS)
38.0	9953.1
42.0	7316.0
46.0	5512.5
50.0	5784.7
54.0	6056.9
58.0	6329.2
62.0	6601.4
66.0	7247.9
70.0	7520.1
74.0	7792.4
78.0	8064.6
82.0	8336.8
86.0	9710.7
90.0	10016.9

GIRDER NUMBER 12

GIRDER WEB DEPTH (IN)	GIRDER WEIGHT (LBS)
38.0	7145.8
42.0	5178.6
46.0	5308.3
50.0	5580.6
54.0	5852.8
58.0	6125.0
62.0	6397.2
66.0	7043.8
70.0	7316.0
74.0	7588.2
78.0	7860.4
82.0	8132.6
86.0	9506.5

TOTAL WEIGHT OF THE GIRDERS WITH THE SAME WEB DEPTH

WEB DEPTH (IN)	TOTAL WEIGHT (LBS)
38.0	90624.5
42.0	71503.0
46.0	65945.8
50.0	69212.5
54.0	72479.2
58.0	75745.8
62.0	79012.5
66.0	86770.8
70.0	90037.5
74.0	93304.2
78.0	96570.8

Design Module, Output File

REQUIRED INPUT DATA
LOAD AND RESISTANCE FACTOR DESIGN

DATA FILE NAME- exal.dat
Lock and Dam #3*
84-ft.-wide lock.
May 1993

—— LEAF GEOMETRY (HORIZONTAL) ——

GATE LENGTH = 48.2500 FT
GIRDER WEB DEPTH = 50.0000 IN
MITER SLOPE = 3.000 TO 1
WORKLINE TO DOWNSTREAM FLANGE = .3333 FT
PINTLE TO QUOIN CONTACT (ALONG WORKLINE) = 1.9792 FT
PINTLE TO WORKLINE = 1.2500 FT
END DIAPHRAGM TO QUOIN CONTACT = 49.5000 IN
END DIAPHRAGM TO MITER CONTACT = 49.5000 IN

NUMBER OF SPACES FOR DIAPHRAGMS AND INTERCOSTALS
PANEL NOS. 1 TO 11 4 5

—— GATE GEOMETRY (VERTICAL) ——

GIRDER NO	WEB LOCATION (DISTANCE ABOVE SILL)
1	56.0000 FT
2	50.0000 FT
3	44.0000 FT
4	38.0000 FT
5	32.0000 FT
6	26.0000 FT
7	21.0000 FT
8	17.0000 FT
9	13.0000 FT
10	9.0000 FT
11	5.0000 FT
12	1.0000 FT

SILL ELEVATION = 46.0000 FT
 DIST FROM SILL TO TOP OF SKIN PLATE = 56.5417 FT
 DIST FROM SILL TO BOT OF SKIN PLATE = .3333 FT
 BOT GIRDER DS FLANGE DOWNWARD EXTENTION = 3.0000 IN

—— STEEL YIELD STRENGTHS ——

WEB	FLANGE	SKINPLATE	STIFFENERS
36.000 KSI	36.000 KSI	36.000 KSI	36.000 KSI
INTERCOSTALS	QUOIN POST & THRUST DIAPH.		DIAGONALS
36.000 KSI	36.000 KSI		60.000 KSI
OTHER STEEL			
36.000 KSI			

—— GATE LOADING ——

ACTIVE LOAD COMBINATION

- 1: 1.4 Hs + 1.0 I
- 2: 1.4 Hs + 1.0 Ht
- 4: 1.2 D + 1.6 (C + M) + 1.0 Ht
- 5: 1.2 D + 1.6 (C + M) + 1.2 Q
- 6: 1.2 Hs + 1.0 E

WATER ELEVATIONS

UPPER POOL = 95.000 FT FULL SUBMERGENCE = 105.500 FT
 LOWER POOL = 64.000 FT OPERATING WATER = 95.000 FT

MINIMUM DESIGN HEAD TEMPORAL HEAD

SKINPLATE	GIRDERS	1.250 FT
6.000 FT	.000 FT	

MISCELLANEOUS LOADS AND LOCATIONS

	DEAD	LIVE	BUOYANCY
CONCENTRATED LOAD	185000.0 LB	.0 LB	.0 LB
DIST FROM QUOIN CONTACT	24.1250 FT	.0000 FT	.0000 FT
OFFSET FROM DS EDGE WEB	25.5000 IN	.0000 IN	.0000 IN

DESIGN PARAMETERS

OPERATING WATER PRESSURE = 30.000 LB/SQFT
 UNIT WEIGHT OF WATER = 62.428 LB/CUFT
 STRUT FORCE = 256000.0 LB
 OBSTRUCTION LOCATION = 46.3000 FT
 EARTHQUAKE ACCEL. FACTOR = .050

GUDGEON PIN LOCATION(FT)

DIST.ALONG W.L. FROM GUDGEON PIN TO STRUT PIN = 19.17

DIST.FROM CL TOP GIRDER WEB TO STRUT CONN. PT = 1.25

INTERMEDIATE DIAPHRAGM DIMENSIONS(IN)

US.FLANGE WIDTH = 4.00

DS.FLANGE WIDTH = 4.00

US.FLANGE THICK SET BY GUFCT

DS.FLANGE THICK = .500

WEB THICKNESS = .500

SKIN PLATE DESIGN

PANEL NO.	PANEL HEIGHT (FT)	PANEL WIDTH (FT)	REQUIRED THICKNESS (IN)
1	5.333	2.000	.5000
2	5.333	2.000	.5000
3	5.333	2.000	.5000
4	5.333	2.000	.5000
5	5.333	2.000	.5000
6	4.333	2.000	.5000
7	3.333	2.000	.5000
8	3.333	2.000	.5000
9	3.333	2.000	.5000
10	3.333	2.000	.5000
11	3.333	2.000	.5000

INTERCOSTAL DESIGN

PANEL NO.	INTERCOSTAL SIZE (IN)	
	LENGTH	WEB THICK
1	2.500	.5000
2	2.500	.6250
3	3.500	.6250
4	5.000	.6250
5	5.500	.6250
6	5.000	.6250
7	4.500	.6250
8	4.500	.6250
9	4.500	.6250
10	4.500	.6250
11	4.500	.6250

GIRDER DESIGN

LOAD FACTOR DESIGN— NON COMPACT SECTION

GIRDER NO.	U.S. FLG.		WEB		D.S. FLG.	
	WIDTH	THICK	WIDTH	THICK	WIDTH	THICK
1 (CEN)	12.000	.500	50.000	.500	12.000	.500
1 (END)	8.000	.500	50.000	.500	12.000	.500
2 (CEN)	12.000	.500	50.000	.500	12.000	.500
2 (END)	8.000	.500	50.000	.500	12.000	.500
3 (CEN)	12.000	.500	50.000	.500	12.000	.500
3 (END)	8.000	.500	50.000	.500	12.000	.500
4 (CEN)	12.000	.500	50.000	.500	12.000	.500
4 (END)	8.000	.500	50.000	.500	12.000	.500
5 (CEN)	12.000	.500	50.000	.500	12.000	.500
5 (END)	8.000	.500	50.000	.500	12.000	.500
6 (CEN)	12.000	.500	50.000	.500	12.000	.500
6 (END)	8.000	.500	50.000	.500	12.000	.500
7 (CEN)	12.000	.500	50.000	.500	12.000	.500
7 (END)	8.000	.500	50.000	.500	12.000	.500
8 (CEN)	12.000	.500	50.000	.500	12.000	.500
8 (END)	8.000	.500	50.000	.500	12.000	.500
9 (CEN)	12.000	.500	50.000	.500	12.000	.500
9 (END)	8.000	.500	50.000	.500	12.000	.500
10 (CEN)	12.000	.500	50.000	.500	12.000	.500
10 (END)	8.000	.500	50.000	.500	12.000	.500
11 (CEN)	12.000	.500	50.000	.500	12.000	.500
11 (END)	8.000	.500	50.000	.500	12.000	.500
12 (CEN)	12.000	.500	50.000	.500	9.000	.500
12 (END)	10.000	.500	50.000	.500	10.500	.500

FLANGE SPLICE DISTANCES

GIRDER

NO.	U.S. FLG.	D.S. FLG.
1	49.500	62.500
2	49.500	62.500
3	49.500	62.500
4	277.500	.000
5	277.500	.000
6	277.500	.000
7	277.500	.000
8	277.500	.000
9	277.500	.000
10	277.500	.000
11	277.500	.000
12	277.500	61.500

WEB STIFFENERS

GIRDER

NO.	LONGITUDINAL			TRANSVERSE		
	NO.	WIDTH	THICK	NO.	WIDTH	THICK
1	2	5.500	.500	0	.000	.000
2	2	5.500	.500	0	.000	.000
3	2	5.500	.500	0	.000	.000
4	2	5.500	.500	0	.000	.000
5	2	5.500	.500	0	.000	.000
6	2	5.500	.500	0	.000	.000
7	2	5.500	.500	0	.000	.000
8	2	5.500	.500	0	.000	.000
9	2	5.500	.500	0	.000	.000
10	2	5.500	.500	0	.000	.000
11	2	5.500	.500	0	.000	.000
12	2	5.500	.500	0	.000	.000

END DIAPHRAGM DESIGN

LOAD AND RESISTANCE FACTOR DESIGN

END DIAPHRAGM DIMENSIONS (IN)

U.S. FLG.		D.S. FLG.		WEB	
WIDTH	THICK	WIDTH	THICK	DEPTH	THICK
4.00	***	4.00	.500	50.00	.563

*** NOTE: US FLG THICK = US FLG THICK OF GIRDER ABOVE IT

QUOIN POST DESIGN

QUOIN CONTACT PLATE
DIMENSIONS (IN)

U.S. PARTIAL		U.S.	D.S.		STIFFENER	
WIDTH	INPUT	WIDTH	WIDTH	THICK	WIDTH	THICK
11.000		11.527	7.076	1.000	6.000	.500

THRUST DIAPHRAGM
DIMENSIONS (IN)

DIAPHRAGM	STIF.WEB	STIF.FLNG	STIF.FLNG	WIDTH
THICK	THICK	THICK	U.S.	D.S.
1.000	1.000	.500	6.000	6.000

QUOIN POST PROPERTIES (IN)

AREA	CENTROID		MOMENT OF INERTIA	
	SQ. IN.	X-DIR	Y-DIR	IX
103.52	23.89	1.39	6176.09	14691.10

POSITIVE STRESSES ARE IN COMPRESSION
 NEGATIVE STRESSES ARE IN TENSION

QUION POST STRESSES (KSI)

-PT. A-	-PT. B-	-PT. C-	-PT. D-	-PT. E-	-PT. F-
10.17	-.82	19.88	-1.72	3.81	5.67

THRUST DIAPHRAGM DESIGN

THRUST DIAPHRAGM STIFFENER AREA (IN**2) .000
 INTERIOR PANEL WIDTH (FT) 2.000
 EXTERIOR PANEL WIDTH (FT) 1.765

PANEL NO.	PANEL HEIGHT (FT)	REQUIRED THICKNESS (IN)
1	6.000	.500
2	6.000	.500
3	6.000	.500
4	6.000	.500
5	6.000	.625
6	5.000	.750
7	4.000	.875
8	4.000	.875
9	4.000	.875
10	4.000	.875
11	4.000	.875

TAPERED END DESIGN

LOAD AND RESISTANCE FACTOR DESIGN

GIRDER NO.	U.S. FLANGE		D.S. FLANGE		WEB
	WIDTH (IN)	THICK (IN)	WIDTH (IN)	THICK (IN)	THICKNESS (IN)
1	8.000	.5000	12.000	.5000	.5000
2	8.000	.5000	12.000	.5000	.5000
3	8.000	.5000	12.000	.5000	.5000
4	8.000	.5000	12.000	.5000	.5000
5	8.000	.5000	12.000	.5000	.5000
6	8.000	.5000	12.000	.5000	.6250
7	8.000	.5000	12.000	.5000	.6250
8	8.000	.5000	12.000	.5000	.5625
9	8.000	.5000	12.000	.5000	.5625
10	8.000	.5000	12.000	.5000	.5625
11	8.000	.5000	12.000	.5000	.5625
12	10.000	.5000	10.500	.5000	.6250

DIAGONAL DESIGN

HORIZONTAL DISTANCE
FROM QUOIN CONTACT (IN)
QUOIN SIDE MITER SIDE

HORIZONTAL SET 1 77.50 501.50

VERTICAL DISTANCE
FROM GIRDER WEB (IN)

	GIRDER AT	GIRDER AT	DISTANCE FROM	DISTANCE FROM
	TOP	BOTTOM	TOP GIRDER	BOTTOM GIRDER

VERTICAL SET 1	1	12	36.75	36.75
----------------	---	----	-------	-------

DISTANCE FROM D.S.
SIDE OF SKIN PLATE (IN)

POSITIVE DIAGONAL	58.375
NEGATIVE DIAGONAL	57.375

LOAD CASE 4 DESIGN STRENGTH 48.6 KSI

GATE DIAGONAL PARAMETERS

EM 1110-2-2703

LINE NO.	ITEM	POS DIAGONAL	NEG DIAGONAL
1	R	.0767	-.0819
2	Q	.17E+10	.15E+10
3	D MINIMUM	6.22	-7.27
4	D-DELTA	15.81	-14.81
5	D MAXIMUM	8.54	-8.59
6	D SELECTED	8.14	-7.27
7	QD	.14E+11	-.11E+11

DIAGONAL STRESSES

8	GATE STATIONARY	25.03	23.87
9	GATE OPENING	5.90	44.28
10	GATE CLOSING	47.39	.02
11	DIAGONAL AREAS	12.00	10.00

LOAD CASE 5 DESIGN STRENGTH 48.6 KSI

GATE DIAGONAL PARAMETERS

EM 1110-2-2703

LINE NO.	ITEM	POS DIAGONAL	NEG DIAGONAL
1	R	.0533	-.0557
2	Q	.25E+10	.24E+10
3	D MINIMUM	9.77	-10.44
4	D-DELTA	22.75	-21.76
5	D MAXIMUM	12.31	-11.99
6	D SELECTED	11.19	-10.45
7	QD	.28E+11	-.25E+11

DIAGONAL STRESSES

8	GATE STATIONARY	23.91	23.33
9	GATE OPENING	3.03	45.16
10	GATE CLOSING	46.22	.00
11	DIAGONAL AREAS	26.00	24.00

GATE PROPERTIES

GATE WT. (STEEL ONLY) 215.43 K

CENTER OF GRAV. (FROM W.L.) 23.12 IN

----- END OF DESIGN MODULE -----

Investigation Module, Output File

REQUIRED INPUT DATA
LOAD AND RESISTANCE FACTOR DESIGN

DATA FILE NAME- exa1.dat
Lock and Dam #3*
84 Ft. Lock.*
May 1993

—— LEAF GEOMETRY (HORIZONTAL) ——

GATE LENGTH = 48.2500 FT
GIRDER WEB DEPTH = 50.0000 IN
MITER SLOPE = 3.000 TO 1
WORKLINE TO DOWNSTREAM FLANGE = .3333 FT
PINTLE TO QUOIN CONTACT (ALONG WORKLINE) = 1.9792 FT
PINTLE TO WORKLINE = 1.2500 FT
END DIAPHRAGM TO QUOIN CONTACT = 49.5000 IN
END DIAPHRAGM TO MITER CONTACT = 49.5000 IN

NUMBER OF SPACES FOR DIAPHRAGMS AND INTERCOSTALS
PANEL NOS. 1 TO 11 4 5

—— GATE GEOMETRY (VERTICAL) ——

GIRDER NO	WEB LOCATION (DISTANCE ABOVE SILL)
1	56.0000 FT
2	50.0000 FT
3	44.0000 FT
4	38.0000 FT
5	32.0000 FT
6	26.0000 FT
7	21.0000 FT
8	17.0000 FT
9	13.0000 FT
10	9.0000 FT
11	5.0000 FT
12	1.0000 FT

SILL ELEVATION = 46.0000 FT
 DIST FROM SILL TO TOP OF SKIN PLATE = 56.5417 FT
 DIST FROM SILL TO BOT OF SKIN PLATE = .3333 FT
 BOT GIRDER DS FLANGE DOWNWARD EXTENTION = 3.0000 IN

—— STEEL YIELD STRENGTHS ——

WEB	FLANGE	SKINPLATE	STIFFENERS
36.000 KSI	36.000 KSI	36.000 KSI	36.000 KSI

INTERCOSTALS	QUOIN POST & THRUST DIAPH.	DIAGONALS
36.000 KSI	36.000 KSI	60.000 KSI

OTHER STEEL	DIAG. TENSILE STRENGHT
36.000 KSI	75.000KSI

—— GATE LOADING ——

ACTIVE LOAD COMBINATION

- 1: 1.4 Hs + 1.0 I
- 2: 1.4 Hs + 1.0 Ht
- 4: 1.2 D + 1.6 (C + M) + 1.0 Ht
- 5: 1.2 D + 1.6 (C + M) + 1.2 Q
- 6: 1.2 Hs + 1.0 E

WATER ELEVATIONS

UPPER POOL = 95.000 FT FULL SUBMERGENCE = 105.500 FT
 LOWER POOL = 64.000 FT OPERATING WATER = 95.000 FT

MINIMUM DESIGN HEAD	TEMPORAL HEAD
SKINPLATE GIRDERS	1.250 FT
6.000 FT .000 FT	

MISCELLANEOUS LOADS AND LOCATIONS

	DEAD	LIVE	BUOYANCY
CONCENTRATED LOAD	185000.0 LB	.0 LB	.0 LB
DIST FROM QUOIN CONTACT	24.1250 FT	.0000 FT	.0000 FT
OFFSET FROM DS EDGE WEB	25.5000 IN	.0000 IN	.0000 IN

DESIGN PARAMETERS

OPERATING WATER PRESSURE = 30.000 LB/SQFT
 UNIT WEIGHT OF WATER = 62.428 LB/CUFT
 STRUT FORCE = 256000.0 LB
 OBSTRUCTION LOCATION = 46.3000 FT
 EARTHQUAKE ACCEL. FACTOR = .050

GUDGEON PIN LOCATION(FT)

DIST.ALONG W.L. FROM GUDGEON PIN TO STRUT PIN = 19.17

DIST.FROM CL TOP GIRDER WEB TO STRUT CONN. PT = 1.25

INTERMEDIATE DIAPHRAGM DIMENSIONS(IN)

US.FLANGE WIDTH = 4.00

DS.FLANGE WIDTH = 4.00

US.FLANGE THICK SET BY GUFCT

DS.FLANGE THICK = .500

WEB THICKNESS = .500

SKIN PLATE INVESTIGATION

PANEL NO.	PANEL HEIGHT (FT)	PANEL WIDTH (FT)	SKIN PLATE THICKNESS (IN)
1	5.000	2.000	.5000
2	5.000	2.000	.5000
3	5.000	2.000	.5000
4	5.000	2.000	.5000
5	5.000	2.000	.5000
6	4.000	2.000	.5000
7	3.000	2.000	.5000
8	3.000	2.000	.5000
9	3.000	2.000	.5000
10	3.000	2.000	.5000
11	3.000	2.000	.5000

LOAD COMBINATION 1

YIELD STRENGTH = 29.2 KSI
 ALL. DEFLECTION = .20 IN
 ALL. STRESS RANGE = 21.0 KSI

PANEL	STRESS (KSI)	DEFLECTION (IN)	STR. RANGE (KSI)
1	.00	.0000	.00
2	3.77	.0060	2.69
3	5.60	.0089	4.00
4	9.76	.0156	6.97
5	13.95	.0223	9.96
6	17.66	.0278	12.61
7	19.86	.0296	14.19
8	20.55	.0307	14.68
9	20.55	.0307	14.68
10	20.55	.0307	14.68
11	20.55	.0307	14.68

LOAD COMBINATION 2

YIELD STRENGTH = 29.2 KSI
 ALL. DEFLECTION = .20 IN
 ALL. STRESS RANGE = 21.0 KSI

PANEL	STRESS (KSI)	DEFLECTION (IN)	STR. RANGE (KSI)
1	.62	.0000	.00
2	2.03	.0060	2.69
3	6.20	.0089	4.00
4	10.39	.0156	6.97
5	14.57	.0223	9.96
6	18.28	.0278	12.61
7	20.45	.0296	14.19
8	21.14	.0307	14.68
9	21.14	.0307	14.68
10	21.14	.0307	14.68
11	21.14	.0307	14.68

LOAD COMBINATION 4

YIELD STRENGTH = 29.2 KSI
 ALL. DEFLECTION = .20 IN
 ALL. STRESS RANGE = 21.0 KSI

PANEL	STRESS (KSI)	DEFLECTION (IN)	STR. RANGE (KSI)
1	.62	.0000	.00
2	.62	.0060	2.69
3	.62	.0089	4.00
4	.62	.0156	6.97
5	.62	.0223	9.96
6	.62	.0278	12.61
7	.59	.0296	14.19
8	.59	.0307	14.68
9	.59	.0307	14.68
10	.59	.0307	14.68
11	.59	.0307	14.68

LOAD COMBINATION 5

YIELD STRENGTH = 29.2 KSI
 ALL. DEFLECTION = .20 IN
 ALL. STRESS RANGE = 21.0 KSI

PANEL	STRESS (KSI)	DEFLECTION (IN)	STR. RANGE (KSI)
1	.00	.0000	.00
2	.26	.0060	2.69
3	.29	.0089	4.00
4	.29	.0156	6.97
5	.29	.0223	9.96
6	.29	.0278	12.61
7	.27	.0296	14.19
8	.27	.0307	14.68
9	.27	.0307	14.68
10	.27	.0307	14.68
11	.27	.0307	14.68

LOAD COMBINATION 6

YIELD STRENGTH = 29.2 KSI
 ALL. DEFLECTION = .20 IN
 ALL. STRESS RANGE = 21.0 KSI

PANEL	STRESS (KSI)	DEFLECTION (IN)	STR. RANGE (KSI)
1	.00	.0000	.00
2	1.40	.0060	2.69
3	5.21	.0089	4.00
4	8.94	.0156	6.97
5	12.64	.0223	9.96
6	15.90	.0278	12.61
7	17.82	.0296	14.19
8	18.61	.0307	14.68
9	18.74	.0307	14.68
10	18.85	.0307	14.68
11	18.94	.0307	14.68

INTERCOSTAL INVESTIGATION

PANEL NO.	OVERALL DEPTH (IN)	STEM THICKNESS (IN)	FLANGE WIDTH (IN)	FLANGE THICKNESS (IN)
1	3.50	.625	.00	.000
2	3.50	.625	.00	.000
3	3.50	.625	.00	.000
4	5.50	.625	.00	.000
5	5.50	.625	.00	.000
6	5.50	.625	.00	.000
7	4.50	.625	.00	.000
8	4.50	.625	.00	.000
9	4.50	.625	.00	.000
10	4.50	.625	.00	.000
11	4.50	.625	.00	.000

LOAD COMBINATION 1

ALL.FATIGUE STRESS RANGE = 29.0 KSI

PANEL	MOMENT FIXED END K*in	MOMENT S.SUPPORT K*in	MOMENT STRENGTH K*in	FATIGUE STRESS RANGE KSI
1	.00	.00	81.35	.00
2	22.03	41.51	81.35	10.63
3	35.62	67.12	81.35	17.18
4	61.69	116.24	183.10	13.22
5	88.12	166.06	183.10	18.89
6	65.22	138.18	183.10	15.72
7	32.76	91.39	127.34	14.95
8	33.99	94.83	127.34	15.51
9	33.99	94.83	127.34	15.51
10	33.99	94.83	127.34	15.51
11	33.99	94.83	127.34	15.51

LOAD COMBINATION 2

ALL.FATIGUE STRESS RANGE = 29.0 KSI

PANEL	MOMENT FIXED END K*in	MOMENT S.SUPPORT K*in	MOMENT STRENGTH K*in	FATIGUE STRESS RANGE KSI
1	3.93	7.41	81.35	.00
2	13.11	24.71	81.35	10.63
3	39.18	73.84	81.35	17.18
4	65.62	123.65	183.10	13.22
5	92.06	173.47	183.10	18.89
6	67.51	143.02	183.10	15.72
7	33.73	94.12	127.34	14.95
8	34.97	97.56	127.34	15.51
9	34.97	97.56	127.34	15.51
10	34.97	97.56	127.34	15.51
11	34.97	97.56	127.34	15.51

LOAD COMBINATION 4

ALL.FATIGUE STRESS RANGE = 29.0 KSI

PANEL	MOMENT FIXED END K*in	MOMENT S.SUPPORT K*in	MOMENT STRENGTH K*in	FATIGUE STRESS RANGE KSI
1	3.93	7.41	81.35	.00
2	3.93	7.41	81.35	10.63
3	3.93	7.41	81.35	17.18
4	3.93	7.41	183.10	13.22
5	3.93	7.41	183.10	18.89
6	2.28	4.84	183.10	15.72
7	.98	2.73	127.34	14.95
8	.98	2.73	127.34	15.51
9	.98	2.73	127.34	15.51
10	.98	2.73	127.34	15.51
11	.98	2.73	127.34	15.51

LOAD COMBINATION 5

ALL.FATIGUE STRESS RANGE = 29.0 KSI

PANEL	MOMENT FIXED END K*in	MOMENT S.SUPPORT K*in	MOMENT STRENGTH K*in	FATIGUE STRESS RANGE KSI
1	.00	.00	81.35	.00
2	1.51	2.85	81.35	10.63
3	1.81	3.42	81.35	17.18
4	1.81	3.42	183.10	13.22
5	1.81	3.42	183.10	18.89
6	1.05	2.23	183.10	15.72
7	.45	1.26	127.34	14.95
8	.45	1.26	127.34	15.51
9	.45	1.26	127.34	15.51
10	.45	1.26	127.34	15.51
11	.45	1.26	127.34	15.51

LOAD COMBINATION 6

ALL.FATIGUE STRESS RANGE = 29.0 KSI

PANEL	MOMENT FIXED END K*in	MOMENT S.SUPPORT K*in	MOMENT STRENGTH K*in	FATIGUE STRESS RANGE KSI
1	.00	.00	81.35	.00
2	9.05	17.06	81.35	10.63
3	32.92	62.04	81.35	17.18
4	56.47	106.42	183.10	13.22
5	79.84	150.45	183.10	18.89
6	58.73	124.42	183.10	15.72
7	29.41	82.06	127.34	14.95
8	30.78	85.87	127.34	15.51
9	31.00	86.47	127.34	15.51
10	31.17	86.96	127.34	15.51
11	31.32	87.39	127.34	15.51

GIRDER INVESTIGATION

UNITS

MOMENTS - KIP*FT.

AXIAL - KIPS

SHEAR - KIPS

GIRDERS WITH ZERO LOAD IN A GIVEN LOAD CASE ARE NOT INVESTIGATED.

SHEAR IS CHECKED @ END DIAPHRAGM ONLY.

GIRDER 1

WEB DEPTH (IN) WEB THICKNESS (IN)
50.000 .500

UPSTREAM

FLANGE PT.3-4 WIDTH THICK.	FLANGE PT.4-CL WIDTH THICK.	COVER PLATE WIDTH THICK.	SPLICE PT. DIST. (IN)	COVER PLATE DIST. (IN)
12.00 .500	12.00 .500	.00 .000	49.5	.0

DOWNSTREAM

FLANGE PT.1-5 WIDTH THICK.	FLANGE PT.5-CL WIDTH THICK.	COVER PLATE WIDTH THICK.	SPLICE PT. DIST. (IN)	COVER PLATE DIST. (IN)
12.00 .500	12.00 .500	.00 .000	62.5	.0

NO.OF TRANSVERSE STIFF. BETWEEN ADJ. DIAPH. 0

LONGITUDINAL STIFFENERS

NO.	DIST.FROM DS.FL. (IN)	WIDTH (IN)	THICKNESS (IN)
1	BOTH SIDES 16.5	5.50	.500
2	BOTH SIDES 33.0	5.50	.500

EFFECTIVE WEB DEPTH (IN) 50.000

SECTION- CENTER LINE LEFT SIDE

IX 20109. IN**4	IY 1207. IN**4	RX 18.27 IN	RY 4.48 IN
KL/RX	31.7	KL/RY	17.4

GIRDER AREA 60.25IN**2

- - - - LOAD COMBINATION 1 - - - -

SYMETRIC IMPACT

MOMENT(KF)= 1380.4 MOMENT STRENGTH(KF)= 2194.5
THRUST(K) = 632.5 AXIAL STRENGTH(K)= 1573.9
COMBINED BENDING FACTOR= .98
FATIGUE STRESS RANGE(KSI)= .00

SHEAR(K)= .0 SHEAR STRENGTH= 313.7

- - - - LOAD COMBINATION 1 - - - -

UNSYMETRIC IMPACT

MOMENT(KF)= 725.2 MOMENT STRENGTH(KF)= 2324.0
THRUST(K) = 346.9 AXIAL STRENGTH(K)= 1573.9
COMBINED BENDING FACTOR= .50
FATIGUE STRESS RANGE(KSI)= .00

SHEAR(K)= .0 SHEAR STRENGTH= 313.7

- - - - LOAD COMBINATION 4 - - - -

MOMENT(KF)= 36.5 MOMENT STRENGTH(KF)= 2324.0
THRUST(K) = 21.1 AXIAL STRENGTH(K)= 1573.9
COMBINED BENDING FACTOR= .02
FATIGUE STRESS RANGE(KSI)= .00

SHEAR(K)= 5.5 SHEAR STRENGTH= 313.7

SECTION- DS FLNG SPLICE RIGHT SIDE

IX 20109. IN**4 IY 1207. IN**4 RX 18.27 IN RY 4.48 IN
KL/RX 31.7 KL/RY 17.4

GIRDER AREA 60.25IN**2

- - - - LOAD COMBINATION 1 - - - -

SYMETRIC IMPACT

MOMENT(KF)= 1380.4 MOMENT STRENGTH(KF)= 2194.5
THRUST(K) = 632.5 AXIAL STRENGTH(K)= 1573.9
COMBINED BENDING FACTOR= .98
FATIGUE STRESS RANGE(KSI)= .00

SHEAR(K)= 5.5 SHEAR STRENGTH= 313.7

- - - - LOAD COMBINATION 1 - - - -
UNSYMMETRIC IMPACT

MOMENT(KF)= 725.2 MOMENT STRENGTH(KF)= 2324.0
THRUST(K) = 346.9 AXIAL STRENGTH(K)= 1573.9
COMBINED BENDING FACTOR= .50
FATIGUE STRESS RANGE(KSI)= .00

SHEAR(K)= 5.5 SHEAR STRENGTH= 313.7

- - - - LOAD COMBINATION 4 - - - -

MOMENT(KF)= 12.9 MOMENT STRENGTH(KF)= 2194.5
THRUST(K) = 21.1 AXIAL STRENGTH(K)= 1573.9
COMBINED BENDING FACTOR= .01
FATIGUE STRESS RANGE(KSI)= .00

SHEAR(K)= 5.5 SHEAR STRENGTH= 313.7

SECTION- DS FLNG SPLICE LEFT SIDE
IX 20109. IN**4 IY 1207. IN**4 RX 18.27 IN RY 4.48 IN
KL/RX 31.7 KL/RX 17.4

GIRDER AREA 60.25IN**2

- - - - LOAD COMBINATION 1 - - - -
SYMMETRIC IMPACT

MOMENT(KF)= 1380.4 MOMENT STRENGTH(KF)= 2194.5
THRUST(K) = 632.5 AXIAL STRENGTH(K)= 1573.9
COMBINED BENDING FACTOR= .98
FATIGUE STRESS RANGE(KSI)= .00

SHEAR(K)= 5.5 SHEAR STRENGTH= 313.7

- - - - LOAD COMBINATION 1 - - - -
UNSYMMETRIC IMPACT

MOMENT(KF)= 725.2 MOMENT STRENGTH(KF)= 2324.0
THRUST(K) = 346.9 AXIAL STRENGTH(K)= 1573.9
COMBINED BENDING FACTOR= .50
FATIGUE STRESS RANGE(KSI)= .00

SHEAR(K)= 5.5 SHEAR STRENGTH= 313.7

- - - - LOAD COMBINATION 4 - - - -

MOMENT (KF) = 12.9 MOMENT STRENGTH (KF) = 2194.5
THRUST (K) = 21.1 AXIAL STRENGTH (K) = 1573.9
COMBINED BENDING FACTOR = .01
FATIGUE STRESS RANGE (KSI) = .00

SHEAR (K) = 5.5 SHEAR STRENGTH = 313.7

SECTION- END DIAPHRAGM RIGHT SIDE
IX 20109. IN**4 IY 1207. IN**4 RX 18.27 IN RY 4.48 IN
 KL/RX 31.7 KL/RY 17.4

GIRDER AREA 60.25IN**2

- - - - LOAD COMBINATION 1 - - - -
 SYMETRIC IMPACT

MOMENT (KF) = 1380.4 MOMENT STRENGTH (KF) = 2194.5
THRUST (K) = 632.5 AXIAL STRENGTH (K) = 1573.9
COMBINED BENDING FACTOR = .98
FATIGUE STRESS RANGE (KSI) = .00

SHEAR (K) = 5.5 SHEAR STRENGTH = 313.7

- - - - LOAD COMBINATION 1 - - - -
 UNSYMETRIC IMPACT

MOMENT (KF) = 725.2 MOMENT STRENGTH (KF) = 2324.0
THRUST (K) = 346.9 AXIAL STRENGTH (K) = 1573.9
COMBINED BENDING FACTOR = .50
FATIGUE STRESS RANGE (KSI) = .00

SHEAR (K) = 5.5 SHEAR STRENGTH = 313.7

- - - - LOAD COMBINATION 4 - - - -

MOMENT (KF) = 18.7 MOMENT STRENGTH (KF) = 2194.5
THRUST (K) = 21.1 AXIAL STRENGTH (K) = 1573.9
COMBINED BENDING FACTOR = .02
FATIGUE STRESS RANGE (KSI) = .00

SHEAR (K) = 5.5 SHEAR STRENGTH = 313.7

----- GIRDER 2 -----

WEB DEPTH (IN) WEB THICKNESS (IN)
50.000 .500

UPSTREAM

FLANGE PT. 3-4 WIDTH THICK.	FLANGE PT. 4-CL WIDTH THICK.	COVER PLATE WIDTH THICK.	SPLICE PT. DIST. (IN)	COVER PLATE DIST. (IN)
12.00 .500	12.00 .500	.00 .000	49.5	.0

DOWNSTREAM

FLANGE PT. 1-5 WIDTH THICK.	FLANGE PT. 5-CL WIDTH THICK.	COVER PLATE WIDTH THICK.	SPLICE PT. DIST. (IN)	COVER PLATE DIST. (IN)
12.00 .500	12.00 .500	.00 .000	62.5	.0

NO. OF TRANSVERSE STIFF. BETWEEN ADJ. DIAPH. 0

LONGITUDINAL STIFFENERS

NO.	DIST. FROM DS. FL. (IN)	WIDTH (IN)	THICKNESS (IN)
1	BOTH SIDES 16.5	5.50	.500
2	BOTH SIDES 33.0	5.50	.500

EFFECTIVE WEB DEPTH (IN) 50.000

SECTION- CENTER LINE	LEFT SIDE
IX 22329. IN**4 IY 2216. IN**4	RX 18.39 IN RY 5.79 IN
KL/RX 31.5	KL/RX 13.5

GIRDER AREA 66.00IN**2

- - - - LOAD COMBINATION 1 - - - -
SYMETRIC IMPACT

MOMENT (KF) = 1474.8	MOMENT STRENGTH (KF) = 2423.5
THRUST (K) = 632.5	AXIAL STRENGTH (K) = 1725.3
COMBINED BENDING FACTOR = .93	
FATIGUE STRESS RANGE (KSI) = .00	

SHEAR (K) = 5.5 SHEAR STRENGTH = 313.7

- - - - LOAD COMBINATION 1 - - - -
UNSYMMETRIC IMPACT

MOMENT (KF) = 673.4 MOMENT STRENGTH (KF) = 2571.0
THRUST (K) = 346.9 AXIAL STRENGTH (K) = 1725.3
COMBINED BENDING FACTOR = .44
FATIGUE STRESS RANGE (KSI) = .00

SHEAR (K) = 5.5 SHEAR STRENGTH = 313.7

- - - - LOAD COMBINATION 2 - - - -

MOMENT (KF) = 40.0 MOMENT STRENGTH (KF) = 2571.0
THRUST (K) = 25.2 AXIAL STRENGTH (K) = 1725.3
COMBINED BENDING FACTOR = .02
FATIGUE STRESS RANGE (KSI) = .00

SHEAR (K) = 6.6 SHEAR STRENGTH = 313.7

- - - - LOAD COMBINATION 4 - - - -

MOMENT (KF) = 56.5 MOMENT STRENGTH (KF) = 2571.0
THRUST (K) = 35.7 AXIAL STRENGTH (K) = 1725.3
COMBINED BENDING FACTOR = .03
FATIGUE STRESS RANGE (KSI) = .00

SHEAR (K) = 9.4 SHEAR STRENGTH = 313.7

- - - - LOAD COMBINATION 5 - - - -

MOMENT (KF) = 8.7 MOMENT STRENGTH (KF) = 2571.0
THRUST (K) = 5.5 AXIAL STRENGTH (K) = 1725.3
COMBINED BENDING FACTOR = .00
FATIGUE STRESS RANGE (KSI) = .00

SHEAR (K) = 1.4 SHEAR STRENGTH = 313.7

- - - - LOAD COMBINATION 6 - - - -

MOMENT (KF) = 22.3 MOMENT STRENGTH (KF) = 2571.0
THRUST (K) = 14.1 AXIAL STRENGTH (K) = 1725.3
COMBINED BENDING FACTOR = .01
FATIGUE STRESS RANGE (KSI) = .00

SHEAR (K) = 3.7 SHEAR STRENGTH = 313.7

SECTION- DS FLNG SPLICE RIGHT SIDE
IX 22329. IN**4 IY 2216. IN**4 RX 18.39 IN RY 5.79 IN
KL/RX 31.5 KL/RY 13.5

GIRDER AREA 66.00IN**2

- - - - LOAD COMBINATION 1 - - - -
SYMETRIC IMPACT

MOMENT(KF)= 1474.8 MOMENT STRENGTH(KF)= 2423.5
THRUST(K) = 632.5 AXIAL STRENGTH(K)= 1725.3
COMBINED BENDING FACTOR= .93
FATIGUE STRESS RANGE(KSI)= .00

SHEAR(K)= 3.7 SHEAR STRENGTH= 313.7

- - - - LOAD COMBINATION 1 - - - -
UNSYMETRIC IMPACT

MOMENT(KF)= 673.4 MOMENT STRENGTH(KF)= 2571.0
THRUST(K) = 346.9 AXIAL STRENGTH(K)= 1725.3
COMBINED BENDING FACTOR= .44
FATIGUE STRESS RANGE(KSI)= .00

SHEAR(K)= 3.7 SHEAR STRENGTH= 313.7

- - - - LOAD COMBINATION 2 - - - -

MOMENT(KF)= 19.2 MOMENT STRENGTH(KF)= 2423.5
THRUST(K) = 25.2 AXIAL STRENGTH(K)= 1725.3
COMBINED BENDING FACTOR= .02
FATIGUE STRESS RANGE(KSI)= .00

SHEAR(K)= 6.6 SHEAR STRENGTH= 313.7

- - - - LOAD COMBINATION 4 - - - -

MOMENT(KF)= 27.2 MOMENT STRENGTH(KF)= 2423.5
THRUST(K) = 35.7 AXIAL STRENGTH(K)= 1725.3
COMBINED BENDING FACTOR= .02
FATIGUE STRESS RANGE(KSI)= .00

SHEAR(K)= 9.4 SHEAR STRENGTH= 313.7

- - - - LOAD COMBINATION 5 - - - -

MOMENT (KF) = 4.2 MOMENT STRENGTH (KF) = 2423.5
THRUST (K) = 5.5 AXIAL STRENGTH (K) = 1725.3
COMBINED BENDING FACTOR = .00
FATIGUE STRESS RANGE (KSI) = .00

SHEAR (K) = 1.4 SHEAR STRENGTH = 313.7

- - - - LOAD COMBINATION 6 - - - -

MOMENT (KF) = 10.7 MOMENT STRENGTH (KF) = 2423.5
THRUST (K) = 14.1 AXIAL STRENGTH (K) = 1725.3
COMBINED BENDING FACTOR = .01
FATIGUE STRESS RANGE (KSI) = .00

SHEAR (K) = 3.7 SHEAR STRENGTH = 313.7

SECTION- DS FLNG SPLICE LEFT SIDE
IX 22329. IN**4 IY 2216. IN**4 RX 18.39 IN RY 5.79 IN
 KL/RX 31.5 KL/RY 13.5

GIRDER AREA 66.00IN**2

- - - - LOAD COMBINATION 1 - - - -

SYMETRIC IMPACT

MOMENT (KF) = 1474.8 MOMENT STRENGTH (KF) = 2423.5
THRUST (K) = 632.5 AXIAL STRENGTH (K) = 1725.3
COMBINED BENDING FACTOR = .93
FATIGUE STRESS RANGE (KSI) = .00

SHEAR (K) = 3.7 SHEAR STRENGTH = 313.7

- - - - LOAD COMBINATION 1 - - - -

UNSYMETRIC IMPACT

MOMENT (KF) = 673.4 MOMENT STRENGTH (KF) = 2571.0
THRUST (K) = 346.9 AXIAL STRENGTH (K) = 1725.3
COMBINED BENDING FACTOR = .44
FATIGUE STRESS RANGE (KSI) = .00

SHEAR (K) = 3.7 SHEAR STRENGTH = 313.7

- - - - LOAD COMBINATION 2 - - - -

MOMENT(KF)= 19.2 MOMENT STRENGTH(KF)= 2423.5
THRUST(K) = 25.2 AXIAL STRENGTH(K)= 1725.3
COMBINED BENDING FACTOR= .02
FATIGUE STRESS RANGE(KSI)= .00

SHEAR(K)= 6.6 SHEAR STRENGTH= 313.7

- - - - LOAD COMBINATION 4 - - - -

MOMENT(KF)= 27.2 MOMENT STRENGTH(KF)= 2423.5
THRUST(K) = 35.7 AXIAL STRENGTH(K)= 1725.3
COMBINED BENDING FACTOR= .02
FATIGUE STRESS RANGE(KSI)= .00

SHEAR(K)= 9.4 SHEAR STRENGTH= 313.7

- - - - LOAD COMBINATION 5 - - - -

MOMENT(KF)= 4.2 MOMENT STRENGTH(KF)= 2423.5
THRUST(K) = 5.5 AXIAL STRENGTH(K)= 1725.3
COMBINED BENDING FACTOR= .00
FATIGUE STRESS RANGE(KSI)= .00

SHEAR(K)= 1.4 SHEAR STRENGTH= 313.7

- - - - LOAD COMBINATION 6 - - - -

MOMENT(KF)= 10.7 MOMENT STRENGTH(KF)= 2423.5
THRUST(K) = 14.1 AXIAL STRENGTH(K)= 1725.3
COMBINED BENDING FACTOR= .01
FATIGUE STRESS RANGE(KSI)= .00

SHEAR(K)= 3.7 SHEAR STRENGTH= 313.7

SECTION- END DIAPHRAGM RIGHT SIDE
IX 22329. IN**4 IY 2216. IN**4 RX 18.39 IN RY 5.79 IN
KL/RX 31.5 KL/RY 13.5

GIRDER AREA 66.00IN**2

- - - - LOAD COMBINATION 1 - - - -
SYMETRIC IMPACT

MOMENT (KF)= 1474.8 MOMENT STRENGTH(KF)= 2423.5
THRUST (K) = 632.5 AXIAL STRENGTH(K)= 1725.3
COMBINED BENDING FACTOR= .93
FATIGUE STRESS RANGE(KSI)= .00

SHEAR (K)= 3.7 SHEAR STRENGTH= 313.7

- - - - LOAD COMBINATION 1 - - - -
UNSYMETRIC IMPACT

MOMENT (KF)= 673.4 MOMENT STRENGTH(KF)= 2571.0
THRUST (K) = 346.9 AXIAL STRENGTH(K)= 1725.3
COMBINED BENDING FACTOR= .44
FATIGUE STRESS RANGE(KSI)= .00

SHEAR (K)= 3.7 SHEAR STRENGTH= 313.7

- - - - LOAD COMBINATION 2 - - - -

MOMENT (KF)= 26.2 MOMENT STRENGTH(KF)= 2423.5
THRUST (K) = 25.2 AXIAL STRENGTH(K)= 1725.3
COMBINED BENDING FACTOR= .02
FATIGUE STRESS RANGE(KSI)= .00

SHEAR (K)= 6.6 SHEAR STRENGTH= 313.7

- - - - LOAD COMBINATION 4 - - - -

MOMENT (KF)= 37.1 MOMENT STRENGTH(KF)= 2423.5
THRUST (K) = 35.7 AXIAL STRENGTH(K)= 1725.3
COMBINED BENDING FACTOR= .03
FATIGUE STRESS RANGE(KSI)= .00

SHEAR (K)= 9.4 SHEAR STRENGTH= 313.7

- - - - LOAD COMBINATION 5 - - - -

MOMENT(KF)= 5.7 MOMENT STRENGTH(KF)= 2423.5
 THRUST(K) = 5.5 AXIAL STRENGTH(K)= 1725.3
 COMBINED BENDING FACTOR= .00
 FATIGUE STRESS RANGE(KSI)= .00

SHEAR(K)= 1.4 SHEAR STRENGTH= 313.7

- - - - LOAD COMBINATION 6 - - - -

MOMENT(KF)= 14.6 MOMENT STRENGTH(KF)= 2423.5
 THRUST(K) = 14.1 AXIAL STRENGTH(K)= 1725.3
 COMBINED BENDING FACTOR= .01
 FATIGUE STRESS RANGE(KSI)= .00

SHEAR(K)= 3.7 SHEAR STRENGTH= 313.7

----- GIRDER 3 -----

WEB DEPTH (IN) 50.000
 WEB THICKNESS (IN) .500

UPSTREAM

FLANGE PT.3-4 WIDTH THICK.	FLANGE PT.4-CL WIDTH THICK.	COVER PLATE WIDTH THICK.	SPLICE PT. DIST. (IN)	COVER PLATE DIST. (IN)
12.00 .500	12.00 .500	.00 .000	49.5	.0

DOWNSTREAM

FLANGE PT.1-5 WIDTH THICK.	FLANGE PT.5-CL WIDTH THICK.	COVER PLATE WIDTH THICK.	SPLICE PT. DIST. (IN)	COVER PLATE DIST. (IN)
12.00 .500	12.00 .500	.00 .000	62.5	.0

NO.OF TRANSVERSE STIFF. BETWEEN ADJ. DIAPH. 0

LONGITUDINAL STIFFENERS

NO.	DIST.FROM DS.FL. (IN)	WIDTH (IN)	THICKNESS (IN)
1	BOTH SIDES 16.5	5.50	.500
2	BOTH SIDES 33.0	5.50	.500

EFFECTIVE WEB DEPTH (IN) 50.000

SECTION- CENTER LINE LEFT SIDE
IX 22329. IN**4 IY 2216. IN**4 RX 18.39 IN RY 5.79 IN
KL/RX 31.5 KL/RY 13.5

GIRDER AREA 66.00IN**2

- - - - LOAD COMBINATION 1 - - - -

SYMETRIC IMPACT

MOMENT (KF)= 1158.1 MOMENT STRENGTH(KF)= 2423.5
THRUST(K) = 832.5 AXIAL STRENGTH(K)= 1725.3
COMBINED BENDING FACTOR= .93
FATIGUE STRESS RANGE(KSI)= 2.36

SHEAR(K)= 52.4 SHEAR STRENGTH= 313.7

- - - - LOAD COMBINATION 1 - - - -

UNSYMETRIC IMPACT

MOMENT (KF)= 708.8 MOMENT STRENGTH(KF)= 2571.0
THRUST(K) = 547.0 AXIAL STRENGTH(K)= 1725.3
COMBINED BENDING FACTOR= .57
FATIGUE STRESS RANGE(KSI)= 2.19

SHEAR(K)= 52.4 SHEAR STRENGTH= 313.7

- - - - LOAD COMBINATION 2 - - - -

MOMENT (KF)= 373.2 MOMENT STRENGTH(KF)= 2571.0
THRUST(K) = 235.8 AXIAL STRENGTH(K)= 1725.3
COMBINED BENDING FACTOR= .22
FATIGUE STRESS RANGE(KSI)= 2.19

SHEAR(K)= 61.8 SHEAR STRENGTH= 313.7

- - - - LOAD COMBINATION 4 - - - -

MOMENT (KF)= 56.5 MOMENT STRENGTH(KF)= 2571.0
THRUST(K) = 35.7 AXIAL STRENGTH(K)= 1725.3
COMBINED BENDING FACTOR= .03
FATIGUE STRESS RANGE(KSI)= 2.19

SHEAR(K)= 9.4 SHEAR STRENGTH= 313.7

- - - - LOAD COMBINATION 5 - - - -

MOMENT(KF)= 26.1 MOMENT STRENGTH(KF)= 2571.0
THRUST(K) = 16.5 AXIAL STRENGTH(K)= 1725.3
COMBINED BENDING FACTOR= .01
FATIGUE STRESS RANGE(KSI)= 2.19

SHEAR(K)= 4.3 SHEAR STRENGTH= 313.7

- - - - LOAD COMBINATION 6 - - - -

MOMENT(KF)= 301.9 MOMENT STRENGTH(KF)= 2571.0
THRUST(K) = 190.7 AXIAL STRENGTH(K)= 1725.3
COMBINED BENDING FACTOR= .17
FATIGUE STRESS RANGE(KSI)= 2.19

SHEAR(K)= 50.0 SHEAR STRENGTH= 313.7

SECTION- DS FLNG SPLICE RIGHT SIDE
IX 22329. IN**4 IY 2216. IN**4 RX 18.39 IN RY 5.79 IN
KL/RX 31.5 KL/RY 13.5

GIRDER AREA 66.00IN**2

- - - - LOAD COMBINATION 1 - - - -

SYMETRIC IMPACT

MOMENT(KF)= 1627.2 MOMENT STRENGTH(KF)= 2423.5
THRUST(K) = 832.5 AXIAL STRENGTH(K)= 1725.3
COMBINED BENDING FACTOR= 1.11
FATIGUE STRESS RANGE(KSI)= 2.01

SHEAR(K)= 52.4 SHEAR STRENGTH= 313.7

- - - - LOAD COMBINATION 1 - - - -

UNSYMETRIC IMPACT

MOMENT(KF)= 708.8 MOMENT STRENGTH(KF)= 2571.0
THRUST(K) = 547.0 AXIAL STRENGTH(K)= 1725.3
COMBINED BENDING FACTOR= .57
FATIGUE STRESS RANGE(KSI)= 2.19

SHEAR(K)= 52.4 SHEAR STRENGTH= 313.7

- - - - LOAD COMBINATION 2 - - - -

MOMENT(KF)= 179.7 MOMENT STRENGTH(KF)= 2423.5
THRUST(K) = 235.8 AXIAL STRENGTH(K)= 1725.3
COMBINED BENDING FACTOR= .14
FATIGUE STRESS RANGE(KSI)= 2.19

SHEAR(K)= 61.8 SHEAR STRENGTH= 313.7

- - - - LOAD COMBINATION 4 - - - -

MOMENT(KF)= 27.2 MOMENT STRENGTH(KF)= 2423.5
THRUST(K) = 35.7 AXIAL STRENGTH(K)= 1725.3
COMBINED BENDING FACTOR= .02
FATIGUE STRESS RANGE(KSI)= 2.19

SHEAR(K)= 9.4 SHEAR STRENGTH= 313.7

- - - - LOAD COMBINATION 5 - - - -

MOMENT(KF)= 12.6 MOMENT STRENGTH(KF)= 2423.5
THRUST(K) = 16.5 AXIAL STRENGTH(K)= 1725.3
COMBINED BENDING FACTOR= .01
FATIGUE STRESS RANGE(KSI)= 2.19

SHEAR(K)= 4.3 SHEAR STRENGTH= 313.7

- - - - LOAD COMBINATION 6 - - - -

MOMENT(KF)= 145.3 MOMENT STRENGTH(KF)= 2423.5
THRUST(K) = 190.7 AXIAL STRENGTH(K)= 1725.3
COMBINED BENDING FACTOR= .12
FATIGUE STRESS RANGE(KSI)= 2.19

SHEAR(K)= 50.0 SHEAR STRENGTH= 313.7

SECTION- DS FLNG SPLICE LEFT SIDE

IX 22329. IN**4 IY 2216. IN**4 RX 18.39 IN RY 5.79 IN
KL/RX 31.5 KL/RY 13.5

GIRDER AREA 66.00IN**2

- - - - LOAD COMBINATION 1 - - - -
SYMETRIC IMPACT

MOMENT(KF)= 1627.2 MOMENT STRENGTH(KF)= 2423.5
THRUST(K) = 832.5 AXIAL STRENGTH(K)= 1725.3
COMBINED BENDING FACTOR= 1.11
FATIGUE STRESS RANGE(KSI)= 2.01

SHEAR(K)= 52.4 SHEAR STRENGTH= 313.7

- - - - LOAD COMBINATION 1 - - - -
UNSYMETRIC IMPACT

MOMENT(KF)= 708.8 MOMENT STRENGTH(KF)= 2571.0
THRUST(K) = 547.0 AXIAL STRENGTH(K)= 1725.3
COMBINED BENDING FACTOR= .57
FATIGUE STRESS RANGE(KSI)= 2.19

SHEAR(K)= 52.4 SHEAR STRENGTH= 313.7

- - - - LOAD COMBINATION 2 - - - -

MOMENT(KF)= 179.7 MOMENT STRENGTH(KF)= 2423.5
THRUST(K) = 235.8 AXIAL STRENGTH(K)= 1725.3
COMBINED BENDING FACTOR= .14
FATIGUE STRESS RANGE(KSI)= 2.19

SHEAR(K)= 61.8 SHEAR STRENGTH= 313.7

- - - - LOAD COMBINATION 4 - - - -

MOMENT(KF)= 27.2 MOMENT STRENGTH(KF)= 2423.5
THRUST(K) = 35.7 AXIAL STRENGTH(K)= 1725.3
COMBINED BENDING FACTOR= .02
FATIGUE STRESS RANGE(KSI)= 2.19

SHEAR(K)= 9.4 SHEAR STRENGTH= 313.7

- - - - LOAD COMBINATION 5 - - - -

MOMENT(KF)= 12.6 MOMENT STRENGTH(KF)= 2423.5
THRUST(K) = 16.5 AXIAL STRENGTH(K)= 1725.3
COMBINED BENDING FACTOR= .01
FATIGUE STRESS RANGE(KSI)= 2.19

SHEAR(K)= 4.3 SHEAR STRENGTH= 313.7

- - - - LOAD COMBINATION 6 - - - -

MOMENT (KF)= 145.3 MOMENT STRENGTH(KF)= 2423.5
THRUST (K) = 190.7 AXIAL STRENGTH(K)= 1725.3
COMBINED BENDING FACTOR= .12
FATIGUE STRESS RANGE(KSI)= 2.19

SHEAR (K)= 50.0 SHEAR STRENGTH= 313.7

SECTION- END DIAPHRAGM RIGHT SIDE
IX 22329. IN**4 IY 2216. IN**4 RX 18.39 IN RY 5.79 IN
 KL/RX 31.5 KL/RY 13.5

 GIRDER AREA 66.00IN**2

- - - - LOAD COMBINATION 1 - - - -
 SYMETRIC IMPACT

MOMENT (KF)= 1682.5 MOMENT STRENGTH(KF)= 2423.5
THRUST (K) = 832.5 AXIAL STRENGTH(K)= 1725.3
COMBINED BENDING FACTOR= 1.13
FATIGUE STRESS RANGE(KSI)= 1.95

SHEAR (K)= 52.4 SHEAR STRENGTH= 313.7

*

- - - - LOAD COMBINATION 1 - - - -
 UNSYMETRIC IMPACT

MOMENT (KF)= 708.8 MOMENT STRENGTH(KF)= 2571.0
THRUST (K) = 547.0 AXIAL STRENGTH(K)= 1725.3
COMBINED BENDING FACTOR= .57
FATIGUE STRESS RANGE(KSI)= 2.19

SHEAR (K)= 52.4 SHEAR STRENGTH= 313.7

- - - - LOAD COMBINATION 2 - - - -

MOMENT (KF)= 244.8 MOMENT STRENGTH(KF)= 2423.5
THRUST (K) = 235.8 AXIAL STRENGTH(K)= 1725.3
COMBINED BENDING FACTOR= .17
FATIGUE STRESS RANGE(KSI)= 2.19

SHEAR (K)= 61.8 SHEAR STRENGTH= 313.7

- - - - LOAD COMBINATION 4 - - - -

MOMENT(KF)= 37.1 MOMENT STRENGTH(KF)= 2423.5
 THRUST(K) = 35.7 AXIAL STRENGTH(K)= 1725.3
 COMBINED BENDING FACTOR= .03
 FATIGUE STRESS RANGE(KSI)= 2.19

SHEAR(K)= 9.4 SHEAR STRENGTH= 313.7

- - - - LOAD COMBINATION 5 - - - -

MOMENT(KF)= 17.1 MOMENT STRENGTH(KF)= 2423.5
 THRUST(K) = 16.5 AXIAL STRENGTH(K)= 1725.3
 COMBINED BENDING FACTOR= .01
 FATIGUE STRESS RANGE(KSI)= 2.19

SHEAR(K)= 4.3 SHEAR STRENGTH= 313.7

- - - - LOAD COMBINATION 6 - - - -

MOMENT(KF)= 198.0 MOMENT STRENGTH(KF)= 2423.5
 THRUST(K) = 190.7 AXIAL STRENGTH(K)= 1725.3
 COMBINED BENDING FACTOR= .14
 FATIGUE STRESS RANGE(KSI)= 2.19

SHEAR(K)= 50.0 SHEAR STRENGTH= 313.7

----- GIRDER 4 -----

WEB DEPTH(IN)				WEB THICKNESS(IN)			
50.000				.500			
UPSTREAM							
FLANGE PT.3-4	FLANGE PT.4-CL	COVER PLATE	SPLICE PT.	COVER PLATE			
WIDTH THICK.	WIDTH THICK.	WIDTH THICK.	DIST. (IN)	DIST. (IN)			
12.00 .500	12.00 .500	.00 .000	49.5	.0			
DOWNSTREAM							
FLANGE PT.1-5	FLANGE PT.5-CL	COVER PLATE	SPLICE PT.	COVER PLATE			
WIDTH THICK.	WIDTH THICK.	WIDTH THICK.	DIST. (IN)	DIST. (IN)			
12.00 .500	12.00 .500	.00 .000	49.5	.0			
NO.OF TRANSVERSE STIFF. BETWEEN ADJ. DIAPH. 0							

LONGITUDINAL STIFFENERS

NO.		DIST.FROM DS.FL. (IN)	WIDTH (IN)	THICKNESS (IN)
1	BOTH SIDES	16.5	5.50	.500
2	BOTH SIDES	33.0	5.50	.500

EFFECTIVE WEB DEPTH (IN) 50.000

SECTION-		CENTER LINE	LEFT SIDE	
IX 22329. IN**4	IY 2216. IN**4	RX 18.39 IN	RY 5.79 IN	
	KL/RX 31.5	KL/RY 13.5		

GIRDER AREA 66.00IN**2

- - - - LOAD COMBINATION 1 - - - -

MOMENT(KF)= 696.7 MOMENT STRENGTH(KF)= 2571.0
 THRUST(K) = 440.1 AXIAL STRENGTH(K)= 1725.3
 COMBINED BENDING FACTOR= .50
 FATIGUE STRESS RANGE(KSI)= 5.19

SHEAR(K)= 115.4 SHEAR STRENGTH= 313.7

- - - - LOAD COMBINATION 2 - - - -

MOMENT(KF)= 753.2 MOMENT STRENGTH(KF)= 2571.0
 THRUST(K) = 475.8 AXIAL STRENGTH(K)= 1725.3
 COMBINED BENDING FACTOR= .54
 FATIGUE STRESS RANGE(KSI)= 5.19

SHEAR(K)= 124.7 SHEAR STRENGTH= 313.7

- - - - LOAD COMBINATION 4 - - - -

MOMENT(KF)= 56.5 MOMENT STRENGTH(KF)= 2571.0
 THRUST(K) = 35.7 AXIAL STRENGTH(K)= 1725.3
 COMBINED BENDING FACTOR= .03
 FATIGUE STRESS RANGE(KSI)= 5.19

SHEAR(K)= 9.4 SHEAR STRENGTH= 313.7

- - - - LOAD COMBINATION 5 - - - -

MOMENT(KF)= 26.1 MOMENT STRENGTH(KF)= 2571.0
THRUST(K) = 16.5 AXIAL STRENGTH(K)= 1725.3
COMBINED BENDING FACTOR= .01
FATIGUE STRESS RANGE(KSI)= 5.19

SHEAR(K)= 4.3 SHEAR STRENGTH= 313.7

- - - - LOAD COMBINATION 6 - - - -

MOMENT(KF)= 643.0 MOMENT STRENGTH(KF)= 2571.0
THRUST(K) = 406.1 AXIAL STRENGTH(K)= 1725.3
COMBINED BENDING FACTOR= .46
FATIGUE STRESS RANGE(KSI)= 5.19

SHEAR(K)= 106.5 SHEAR STRENGTH= 313.7

SECTION- END DIAPHRAGM RIGHT SIDE
IX 22329. IN**4 IY 2216. IN**4 RX 18.39 IN RY 5.79 IN
KL/RX 31.5 KL/RY 13.5

GIRDER AREA 66.00IN**2

- - - - LOAD COMBINATION 1 - - - -

MOMENT(KF)= 457.0 MOMENT STRENGTH(KF)= 2423.5
THRUST(K) = 440.1 AXIAL STRENGTH(K)= 1725.3
COMBINED BENDING FACTOR= .43
FATIGUE STRESS RANGE(KSI)= 4.29

SHEAR(K)= 115.4 SHEAR STRENGTH= 313.7

- - - - LOAD COMBINATION 2 - - - -

MOMENT(KF)= 494.1 MOMENT STRENGTH(KF)= 2423.5
THRUST(K) = 475.8 AXIAL STRENGTH(K)= 1725.3
COMBINED BENDING FACTOR= .46
FATIGUE STRESS RANGE(KSI)= 4.29

SHEAR(K)= 124.7 SHEAR STRENGTH= 313.7

- - - - LOAD COMBINATION 4 - - - -

MOMENT (KF)= 37.1 MOMENT STRENGTH(KF)= 2423.5
 THRUST (K) = 35.7 AXIAL STRENGTH(K)= 1725.3
 COMBINED BENDING FACTOR= .03
 FATIGUE STRESS RANGE(KSI)= 4.29

SHEAR(K)= 9.4 SHEAR STRENGTH= 313.7

- - - - LOAD COMBINATION 5 - - - -

MOMENT (KF)= 17.1 MOMENT STRENGTH(KF)= 2423.5
 THRUST (K) = 16.5 AXIAL STRENGTH(K)= 1725.3
 COMBINED BENDING FACTOR= .01
 FATIGUE STRESS RANGE(KSI)= 4.29

SHEAR(K)= 4.3 SHEAR STRENGTH= 313.7

- - - - LOAD COMBINATION 6 - - - -

MOMENT (KF)= 421.7 MOMENT STRENGTH(KF)= 2423.5
 THRUST (K) = 406.1 AXIAL STRENGTH(K)= 1725.3
 COMBINED BENDING FACTOR= .39
 FATIGUE STRESS RANGE(KSI)= 4.29

SHEAR(K)= 106.5 SHEAR STRENGTH= 313.7

----- GIRDER 5 -----

WEB DEPTH (IN)		WEB THICKNESS (IN)					
50.000		.500					
UPSTREAM							
FLANGE PT. 3-4	FLANGE PT. 4-CL	COVER PLATE	SPLICE PT.	COVER PLATE			
WIDTH THICK.	WIDTH THICK.	WIDTH THICK.	DIST. (IN)	DIST. (IN)			
12.00	.500	12.00	.500	.00	.000	49.5	.0
DOWNSTREAM							
FLANGE PT. 1-5	FLANGE PT. 5-CL	COVER PLATE	SPLICE PT.	COVER PLATE			
WIDTH THICK.	WIDTH THICK.	WIDTH THICK.	DIST. (IN)	DIST. (IN)			
12.00	.500	12.00	.500	.00	.000	49.5	.0

NO.OF TRANSVERSE STIFF. BETWEEN ADJ. DIAPH. 0

LONGITUDINAL STIFFENERS

NO.		DIST.FROM DS.FL. (IN)	WIDTH (IN)	THICKNESS (IN)
1	BOTH SIDES	16.5	5.50	.500
2	BOTH SIDES	33.0	5.50	.500

EFFECTIVE WEB DEPTH (IN) 50.000

SECTION-		CENTER LINE	LEFT SIDE	
IX 22329.	IN**4	IY 2216.	IN**4	RX 18.39 IN RY 5.79 IN
		KL/RX	31.5	KL/RY 13.5

GIRDER AREA 66.00IN**2

- - - - LOAD COMBINATION 1 - - - -

MOMENT(KF)= 1076.7 MOMENT STRENGTH(KF)= 2571.0
 THRUST(K) = 680.1 AXIAL STRENGTH(K)= 1725.3
 COMBINED BENDING FACTOR= .78
 FATIGUE STRESS RANGE(KSI)= 8.02

SHEAR(K)= 178.3 SHEAR STRENGTH= 313.7

- - - - LOAD COMBINATION 2 - - - -

MOMENT(KF)= 1133.3 MOMENT STRENGTH(KF)= 2571.0
 THRUST(K) = 715.8 AXIAL STRENGTH(K)= 1725.3
 COMBINED BENDING FACTOR= .82
 FATIGUE STRESS RANGE(KSI)= 8.02

SHEAR(K)= 187.7 SHEAR STRENGTH= 313.7

- - - - LOAD COMBINATION 4 - - - -

MOMENT(KF)= 56.5 MOMENT STRENGTH(KF)= 2571.0
 THRUST(K) = 35.7 AXIAL STRENGTH(K)= 1725.3
 COMBINED BENDING FACTOR= .03
 FATIGUE STRESS RANGE(KSI)= 8.02

SHEAR(K)= 9.4 SHEAR STRENGTH= 313.7

- - - - LOAD COMBINATION 5 - - - -

MOMENT(KF)= 26.1 MOMENT STRENGTH(KF)= 2571.0
THRUST(K) = 16.5 AXIAL STRENGTH(K)= 1725.3
COMBINED BENDING FACTOR= .01
FATIGUE STRESS RANGE(KSI)= 8.02

SHEAR(K)= 4.3 SHEAR STRENGTH= 313.7

- - - - LOAD COMBINATION 6 - - - -

MOMENT(KF)= 979.9 MOMENT STRENGTH(KF)= 2571.0
THRUST(K) = 619.0 AXIAL STRENGTH(K)= 1725.3
COMBINED BENDING FACTOR= .71
FATIGUE STRESS RANGE(KSI)= 8.02

SHEAR(K)= 162.3 SHEAR STRENGTH= 313.7

SECTION- END DIAPHRAGM RIGHT SIDE
IX 22329. IN**4 IY 2216. IN**4 RX 18.39 IN RY 5.79 IN
 KL/RX 31.5 KL/RY 13.5

GIRDER AREA 66.00IN**2

- - - - LOAD COMBINATION 1 - - - -

MOMENT(KF)= 706.2 MOMENT STRENGTH(KF)= 2423.5
THRUST(K) = 680.1 AXIAL STRENGTH(K)= 1725.3
COMBINED BENDING FACTOR= .66
FATIGUE STRESS RANGE(KSI)= 6.63

SHEAR(K)= 178.3 SHEAR STRENGTH= 313.7

- - - - LOAD COMBINATION 2 - - - -

MOMENT(KF)= 743.3 MOMENT STRENGTH(KF)= 2423.5
THRUST(K) = 715.8 AXIAL STRENGTH(K)= 1725.3
COMBINED BENDING FACTOR= .70
FATIGUE STRESS RANGE(KSI)= 6.63

SHEAR(K)= 187.7 SHEAR STRENGTH= 313.7

- - - - LOAD COMBINATION 4 - - - -

MOMENT (KF) = 37.1 MOMENT STRENGTH (KF) = 2423.5
 THRUST (K) = 35.7 AXIAL STRENGTH (K) = 1725.3
 COMBINED BENDING FACTOR = .03
 FATIGUE STRESS RANGE (KSI) = 6.63

SHEAR (K) = 9.4 SHEAR STRENGTH = 313.7

- - - - LOAD COMBINATION 5 - - - -

MOMENT (KF) = 17.1 MOMENT STRENGTH (KF) = 2423.5
 THRUST (K) = 16.5 AXIAL STRENGTH (K) = 1725.3
 COMBINED BENDING FACTOR = .01
 FATIGUE STRESS RANGE (KSI) = 6.63

SHEAR (K) = 4.3 SHEAR STRENGTH = 313.7

- - - - LOAD COMBINATION 6 - - - -

MOMENT (KF) = 642.8 MOMENT STRENGTH (KF) = 2423.5
 THRUST (K) = 619.0 AXIAL STRENGTH (K) = 1725.3
 COMBINED BENDING FACTOR = .60
 FATIGUE STRESS RANGE (KSI) = 6.63

SHEAR (K) = 162.3 SHEAR STRENGTH = 313.7

----- GIRDER 6 -----

WEB DEPTH (IN)		WEB THICKNESS (IN)					
50.000		.500					
UPSTREAM							
FLANGE PT. 3-4	FLANGE PT. 4-CL	COVER PLATE	SPLICE PT.	COVER PLATE			
WIDTH THICK.	WIDTH THICK.	WIDTH THICK.	DIST. (IN)	DIST. (IN)			
12.00 .500	12.00 .500	.00 .000	49.5	.0			
DOWNSTREAM							
FLANGE PT. 1-5	FLANGE PT. 5-CL	COVER PLATE	SPLICE PT.	COVER PLATE			
WIDTH THICK.	WIDTH THICK.	WIDTH THICK.	DIST. (IN)	DIST. (IN)			
12.00 .500	12.00 .500	.00 .000	49.5	.0			
NO. OF TRANSVERSE STIFF. BETWEEN ADJ. DIAPH. 0							

LONGITUDINAL STIFFENERS

NO.		DIST.FROM DS.FL. (IN)	WIDTH (IN)	THICKNESS (IN)
1	BOTH SIDES	16.5	5.50	.500
2	BOTH SIDES	33.0	5.50	.500

EFFECTIVE WEB DEPTH (IN) 50.000

SECTION- CENTER LINE LEFT SIDE
 IX 22329. IN**4 IY 2216. IN**4 RX 18.39 IN RY 5.79 IN
 KL/RX 31.5 KL/RY 13.5

GIRDER AREA 66.00IN**2

- - - - LOAD COMBINATION 1 - - - -

MOMENT (KF) = 1320.8 MOMENT STRENGTH (KF) = 2571.0
 THRUST (K) = 834.3 AXIAL STRENGTH (K) = 1725.3
 COMBINED BENDING FACTOR = .96
 FATIGUE STRESS RANGE (KSI) = 9.83

SHEAR (K) = 218.7 SHEAR STRENGTH = 313.7

- - - - LOAD COMBINATION 2 - - - -

MOMENT (KF) = 1372.6 MOMENT STRENGTH (KF) = 2571.0
 THRUST (K) = 867.1 AXIAL STRENGTH (K) = 1725.3
 COMBINED BENDING FACTOR = 1.00
 FATIGUE STRESS RANGE (KSI) = 9.83

SHEAR (K) = 227.3 SHEAR STRENGTH = 313.7

- - - - LOAD COMBINATION 4 - - - -

MOMENT (KF) = 51.8 MOMENT STRENGTH (KF) = 2571.0
 THRUST (K) = 32.7 AXIAL STRENGTH (K) = 1725.3
 COMBINED BENDING FACTOR = .03
 FATIGUE STRESS RANGE (KSI) = 9.83

SHEAR (K) = 8.6 SHEAR STRENGTH = 313.7

- - - - LOAD COMBINATION 5 - - - -

MOMENT(KF)= 23.9 MOMENT STRENGTH(KF)= 2571.0
THRUST(K) = 15.1 AXIAL STRENGTH(K)= 1725.3
COMBINED BENDING FACTOR= .01
FATIGUE STRESS RANGE(KSI)= 9.83

SHEAR(K)= 4.0 SHEAR STRENGTH= 313.7

- - - - LOAD COMBINATION 6 - - - -

MOMENT(KF)= 1192.7 MOMENT STRENGTH(KF)= 2571.0
THRUST(K) = 753.4 AXIAL STRENGTH(K)= 1725.3
COMBINED BENDING FACTOR= .87
FATIGUE STRESS RANGE(KSI)= 9.83

SHEAR(K)= 197.5 SHEAR STRENGTH= 313.7

SECTION- END DIAPHRAGM RIGHT SIDE
IX 22329. IN**4 IY 2216. IN**4 RX 18.39 IN RY 5.79 IN
KL/RX 31.5 KL/RY 13.5

GIRDER AREA 66.00IN**2

- - - - LOAD COMBINATION 1 - - - -

MOMENT(KF)= 866.4 MOMENT STRENGTH(KF)= 2423.5
THRUST(K) = 834.3 AXIAL STRENGTH(K)= 1725.3
COMBINED BENDING FACTOR= .82
FATIGUE STRESS RANGE(KSI)= 8.13

SHEAR(K)= 218.7 SHEAR STRENGTH= 313.7

- - - - LOAD COMBINATION 2 - - - -

MOMENT(KF)= 900.4 MOMENT STRENGTH(KF)= 2423.5
THRUST(K) = 867.1 AXIAL STRENGTH(K)= 1725.3
COMBINED BENDING FACTOR= .85
FATIGUE STRESS RANGE(KSI)= 8.13

SHEAR(K)= 227.3 SHEAR STRENGTH= 313.7

- - - - LOAD COMBINATION 4 - - - -

MOMENT(KF)= 34.0 MOMENT STRENGTH(KF)= 2423.5
 THRUST(K) = 32.7 AXIAL STRENGTH(K)= 1725.3
 COMBINED BENDING FACTOR= .02
 FATIGUE STRESS RANGE(KSI)= 8.13

SHEAR(K)= 8.6 SHEAR STRENGTH= 313.7

- - - - LOAD COMBINATION 5 - - - -

MOMENT(KF)= 15.7 MOMENT STRENGTH(KF)= 2423.5
 THRUST(K) = 15.1 AXIAL STRENGTH(K)= 1725.3
 COMBINED BENDING FACTOR= .01
 FATIGUE STRESS RANGE(KSI)= 8.13

SHEAR(K)= 4.0 SHEAR STRENGTH= 313.7

- - - - LOAD COMBINATION 6 - - - -

MOMENT(KF)= 782.3 MOMENT STRENGTH(KF)= 2423.5
 THRUST(K) = 753.4 AXIAL STRENGTH(K)= 1725.3
 COMBINED BENDING FACTOR= .74
 FATIGUE STRESS RANGE(KSI)= 8.13

SHEAR(K)= 197.5 SHEAR STRENGTH= 313.7

----- GIRDER 7 -----

WEB DEPTH(IN) WEB THICKNESS(IN)
 50.000 .500

UPSTREAM

FLANGE PT.3-4 WIDTH	FLANGE PT.4-CL THICK.	FLANGE PT.4-CL WIDTH	FLANGE PT.4-CL THICK.	COVER PLATE WIDTH	COVER PLATE THICK.	SPLICE PT. DIST. (IN)	COVER PLATE DIST. (IN)
12.00	.500	12.00	.500	.00	.000	49.5	.0

DOWNSTREAM

FLANGE PT.1-5 WIDTH	FLANGE PT.5-CL THICK.	FLANGE PT.5-CL WIDTH	FLANGE PT.5-CL THICK.	COVER PLATE WIDTH	COVER PLATE THICK.	SPLICE PT. DIST. (IN)	COVER PLATE DIST. (IN)
12.00	.500	12.00	.500	.00	.000	49.5	.0

NO.OF TRANSVERSE STIFF. BETWEEN ADJ. DIAPH. 0

LONGITUDINAL STIFFENERS

NO.		DIST.FROM DS.FL. (IN)	WIDTH (IN)	THICKNESS (IN)
1	BOTH SIDES	16.5	5.50	.500
2	BOTH SIDES	33.0	5.50	.500

EFFECTIVE WEB DEPTH (IN) 50.000

SECTION-		CENTER LINE	LEFT SIDE	
IX 22329. IN**4	IY 2216. IN**4	RX 18.39 IN	RY 5.79 IN	
	KL/RX 31.5		KL/RY 13.5	

GIRDER AREA 66.00IN**2

- - - - LOAD COMBINATION 1 - - - -

MOMENT (KF)= 1318.2 MOMENT STRENGTH (KF)= 2571.0
 THRUST (K) = 832.6 AXIAL STRENGTH (K)= 1725.3
 COMBINED BENDING FACTOR= .96
 FATIGUE STRESS RANGE (KSI)= 9.81

SHEAR (K)= 218.3 SHEAR STRENGTH= 313.7

- - - - LOAD COMBINATION 2 - - - -

MOMENT (KF)= 1360.6 MOMENT STRENGTH (KF)= 2571.0
 THRUST (K) = 859.4 AXIAL STRENGTH (K)= 1725.3
 COMBINED BENDING FACTOR= .99
 FATIGUE STRESS RANGE (KSI)= 9.81

SHEAR (K)= 225.3 SHEAR STRENGTH= 313.7

- - - - LOAD COMBINATION 4 - - - -

MOMENT (KF)= 42.4 MOMENT STRENGTH (KF)= 2571.0
 THRUST (K) = 26.8 AXIAL STRENGTH (K)= 1725.3
 COMBINED BENDING FACTOR= .02
 FATIGUE STRESS RANGE (KSI)= 9.81

SHEAR (K)= 7.0 SHEAR STRENGTH= 313.7

- - - - LOAD COMBINATION 5 - - - -

MOMENT(KF)= 19.6 MOMENT STRENGTH(KF)= 2571.0
THRUST(K) = 12.4 AXIAL STRENGTH(K)= 1725.3
COMBINED BENDING FACTOR= .01
FATIGUE STRESS RANGE(KSI)= 9.81

SHEAR(K)= 3.2 SHEAR STRENGTH= 313.7

- - - - LOAD COMBINATION 6 - - - -

MOMENT(KF)= 1184.6 MOMENT STRENGTH(KF)= 2571.0
THRUST(K) = 748.3 AXIAL STRENGTH(K)= 1725.3
COMBINED BENDING FACTOR= .86
FATIGUE STRESS RANGE(KSI)= 9.81

SHEAR(K)= 196.2 SHEAR STRENGTH= 313.7

SECTION- END DIAPHRAGM RIGHT SIDE
IX 22329. IN**4 IY 2216. IN**4 RX 18.39 IN RY 5.79 IN
KL/RX 31.5 KL/RY 13.5

GIRDER AREA 66.00IN**2

- - - - LOAD COMBINATION 1 - - - -

MOMENT(KF)= 864.6 MOMENT STRENGTH(KF)= 2423.5
THRUST(K) = 832.6 AXIAL STRENGTH(K)= 1725.3
COMBINED BENDING FACTOR= .81
FATIGUE STRESS RANGE(KSI)= 8.11

SHEAR(K)= 218.3 SHEAR STRENGTH= 313.7

- - - - LOAD COMBINATION 2 - - - -

MOMENT(KF)= 892.4 MOMENT STRENGTH(KF)= 2423.5
THRUST(K) = 859.4 AXIAL STRENGTH(K)= 1725.3
COMBINED BENDING FACTOR= .84
FATIGUE STRESS RANGE(KSI)= 8.11

SHEAR(K)= 225.3 SHEAR STRENGTH= 313.7

- - - - LOAD COMBINATION 4 - - - -

MOMENT(KF)= 27.8 MOMENT STRENGTH(KF)= 2423.5
 THRUST(K) = 26.8 AXIAL STRENGTH(K)= 1725.3
 COMBINED BENDING FACTOR= .02
 FATIGUE STRESS RANGE(KSI)= 8.11

SHEAR(K)= 7.0 SHEAR STRENGTH= 313.7

- - - - LOAD COMBINATION 5 - - - -

MOMENT(KF)= 12.8 MOMENT STRENGTH(KF)= 2423.5
 THRUST(K) = 12.4 AXIAL STRENGTH(K)= 1725.3
 COMBINED BENDING FACTOR= .01
 FATIGUE STRESS RANGE(KSI)= 8.11

SHEAR(K)= 3.2 SHEAR STRENGTH= 313.7

- - - - LOAD COMBINATION 6 - - - -

MOMENT(KF)= 777.0 MOMENT STRENGTH(KF)= 2423.5
 THRUST(K) = 748.3 AXIAL STRENGTH(K)= 1725.3
 COMBINED BENDING FACTOR= .73
 FATIGUE STRESS RANGE(KSI)= 8.11

SHEAR(K)= 196.2 SHEAR STRENGTH= 313.7

----- GIRDER 8 -----

WEB DEPTH(IN) WEB THICKNESS(IN)
 50.000 .500

UPSTREAM

FLANGE PT. 3-4	FLANGE PT. 4-CL	COVER PLATE	SPLICE PT.	COVER PLATE
WIDTH THICK.	WIDTH THICK.	WIDTH THICK.	DIST. (IN)	DIST. (IN)
12.00 .500	12.00 .500	.00 .000	49.5	.0

DOWNSTREAM

FLANGE PT. 1-5	FLANGE PT. 5-CL	COVER PLATE	SPLICE PT.	COVER PLATE
WIDTH THICK.	WIDTH THICK.	WIDTH THICK.	DIST. (IN)	DIST. (IN)
12.00 .500	12.00 .500	.00 .000	49.5	.0

NO. OF TRANSVERSE STIFF. BETWEEN ADJ. DIAPH. 0

LONGITUDINAL STIFFENERS

NO.		DIST.FROM DS.FL. (IN)	WIDTH (IN)	THICKNESS (IN)
1	BOTH SIDES	16.5	5.50	.500
2	BOTH SIDES	33.0	5.50	.500

EFFECTIVE WEB DEPTH (IN) 50.000

SECTION-		CENTER LINE	LEFT SIDE	
IX 22329. IN**4	IY 2216. IN**4	RX 18.39 IN	RY 5.79 IN	
	KL/RX 31.5	KL/RY 13.5		

GIRDER AREA 66.00IN**2

- - - - LOAD COMBINATION 1 - - - -

MOMENT (KF) = 1303.7 MOMENT STRENGTH (KF) = 2571.0
 THRUST (K) = 823.5 AXIAL STRENGTH (K) = 1725.3
 COMBINED BENDING FACTOR = .95
 FATIGUE STRESS RANGE (KSI) = 9.70

SHEAR (K) = 215.9 SHEAR STRENGTH = 313.7

- - - - LOAD COMBINATION 2 - - - -

MOMENT (KF) = 1341.4 MOMENT STRENGTH (KF) = 2571.0
 THRUST (K) = 847.3 AXIAL STRENGTH (K) = 1725.3
 COMBINED BENDING FACTOR = .98
 FATIGUE STRESS RANGE (KSI) = 9.70

SHEAR (K) = 222.1 SHEAR STRENGTH = 313.7

- - - - LOAD COMBINATION 4 - - - -

MOMENT (KF) = 37.7 MOMENT STRENGTH (KF) = 2571.0
 THRUST (K) = 23.8 AXIAL STRENGTH (K) = 1725.3
 COMBINED BENDING FACTOR = .02
 FATIGUE STRESS RANGE (KSI) = 9.70

SHEAR (K) = 6.2 SHEAR STRENGTH = 313.7

- - - - LOAD COMBINATION 5 - - - -

MOMENT(KF)= 17.4 MOMENT STRENGTH(KF)= 2571.0
THRUST(K) = 11.0 AXIAL STRENGTH(K)= 1725.3
COMBINED BENDING FACTOR= .01
FATIGUE STRESS RANGE(KSI)= 9.70

SHEAR(K)= 2.9 SHEAR STRENGTH= 313.7

- - - - LOAD COMBINATION 6 - - - -

MOMENT(KF)= 1174.4 MOMENT STRENGTH(KF)= 2571.0
THRUST(K) = 741.8 AXIAL STRENGTH(K)= 1725.3
COMBINED BENDING FACTOR= .85
FATIGUE STRESS RANGE(KSI)= 9.70

SHEAR(K)= 194.5 SHEAR STRENGTH= 313.7

SECTION- END DIAPHRAGM RIGHT SIDE
IX 22329. IN**4 IY 2216. IN**4 RX 18.39 IN RY 5.79 IN
 KL/RX 31.5 KL/RX 13.5

GIRDER AREA 66.00IN**2

- - - - LOAD COMBINATION 1 - - - -

MOMENT(KF)= 855.1 MOMENT STRENGTH(KF)= 2423.5
THRUST(K) = 823.5 AXIAL STRENGTH(K)= 1725.3
COMBINED BENDING FACTOR= .81
FATIGUE STRESS RANGE(KSI)= 8.02

SHEAR(K)= 215.9 SHEAR STRENGTH= 313.7

- - - - LOAD COMBINATION 2 - - - -

MOMENT(KF)= 879.8 MOMENT STRENGTH(KF)= 2423.5
THRUST(K) = 847.3 AXIAL STRENGTH(K)= 1725.3
COMBINED BENDING FACTOR= .83
FATIGUE STRESS RANGE(KSI)= 8.02

SHEAR(K)= 222.1 SHEAR STRENGTH= 313.7

- - - - LOAD COMBINATION 4 - - - -

MOMENT (KF) = 24.7 MOMENT STRENGTH (KF) = 2423.5
 THRUST (K) = 23.8 AXIAL STRENGTH (K) = 1725.3
 COMBINED BENDING FACTOR = .02
 FATIGUE STRESS RANGE (KSI) = 8.02

SHEAR (K) = 6.2 SHEAR STRENGTH = 313.7

- - - - LOAD COMBINATION 5 - - - -

MOMENT (KF) = 11.4 MOMENT STRENGTH (KF) = 2423.5
 THRUST (K) = 11.0 AXIAL STRENGTH (K) = 1725.3
 COMBINED BENDING FACTOR = .01
 FATIGUE STRESS RANGE (KSI) = 8.02

SHEAR (K) = 2.9 SHEAR STRENGTH = 313.7

- - - - LOAD COMBINATION 6 - - - -

MOMENT (KF) = 770.3 MOMENT STRENGTH (KF) = 2423.5
 THRUST (K) = 741.8 AXIAL STRENGTH (K) = 1725.3
 COMBINED BENDING FACTOR = .72
 FATIGUE STRESS RANGE (KSI) = 8.02

SHEAR (K) = 194.5 SHEAR STRENGTH = 313.7

----- GIRDER 9 -----

WEB DEPTH (IN)		WEB THICKNESS (IN)					
50.000		.500					
UPSTREAM							
FLANGE PT. 3-4	FLANGE PT. 4-CL	COVER PLATE	SPLICE PT.	COVER PLATE			
WIDTH THICK.	WIDTH THICK.	WIDTH THICK.	DIST. (IN)	DIST. (IN)			
12.00 .500	12.00 .500	.00 .000	49.5	.0			
DOWNSTREAM							
FLANGE PT. 1-5	FLANGE PT. 5-CL	COVER PLATE	SPLICE PT.	COVER PLATE			
WIDTH THICK.	WIDTH THICK.	WIDTH THICK.	DIST. (IN)	DIST. (IN)			
12.00 .500	12.00 .500	.00 .000	49.5	.0			
NO. OF TRANSVERSE STIFF. BETWEEN ADJ. DIAPH. 0							

LONGITUDINAL STIFFENERS

NO.		DIST.FROM DS.FL. (IN)	WIDTH (IN)	THICKNESS (IN)
1	BOTH SIDES	16.5	5.50	.500
2	BOTH SIDES	33.0	5.50	.500

EFFECTIVE WEB DEPTH (IN) 50.000

		SECTION- CENTER LINE	LEFT SIDE	
IX 22329. IN**4	IY 2216. IN**4	RX 18.39 IN	RY 5.79 IN	
	KL/RX 31.5		KL/RY 13.5	

GIRDER AREA 66.00IN**2

- - - - LOAD COMBINATION 1 - - - -

MOMENT(KF)= 1308.9 MOMENT STRENGTH(KF)= 2571.0
 THRUST(K) = 826.8 AXIAL STRENGTH(K)= 1725.3
 COMBINED BENDING FACTOR= .95
 FATIGUE STRESS RANGE(KSI)= 9.74

SHEAR(K)= 216.8 SHEAR STRENGTH= 313.7

- - - - LOAD COMBINATION 2 - - - -

MOMENT(KF)= 1346.6 MOMENT STRENGTH(KF)= 2571.0
 THRUST(K) = 850.6 AXIAL STRENGTH(K)= 1725.3
 COMBINED BENDING FACTOR= .98
 FATIGUE STRESS RANGE(KSI)= 9.74

SHEAR(K)= 223.0 SHEAR STRENGTH= 313.7

- - - - LOAD COMBINATION 4 - - - -

MOMENT(KF)= 37.7 MOMENT STRENGTH(KF)= 2571.0
 THRUST(K) = 23.8 AXIAL STRENGTH(K)= 1725.3
 COMBINED BENDING FACTOR= .02
 FATIGUE STRESS RANGE(KSI)= 9.74

SHEAR(K)= 6.2 SHEAR STRENGTH= 313.7

- - - - LOAD COMBINATION 5 - - - -

MOMENT (KF) = 17.4 MOMENT STRENGTH (KF) = 2571.0
THRUST (K) = 11.0 AXIAL STRENGTH (K) = 1725.3
COMBINED BENDING FACTOR = .01
FATIGUE STRESS RANGE (KSI) = 9.74

SHEAR (K) = 2.9 SHEAR STRENGTH = 313.7

- - - - LOAD COMBINATION 6 - - - -

MOMENT (KF) = 1189.8 MOMENT STRENGTH (KF) = 2571.0
THRUST (K) = 751.5 AXIAL STRENGTH (K) = 1725.3
COMBINED BENDING FACTOR = .86
FATIGUE STRESS RANGE (KSI) = 9.74

SHEAR (K) = 197.0 SHEAR STRENGTH = 313.7

SECTION- END DIAPHRAGM RIGHT SIDE
IX 22329. IN**4 IY 2216. IN**4 RX 18.39 IN RY 5.79 IN
 KL/RX 31.5 KL/RY 13.5

GIRDER AREA 66.00IN**2

- - - - LOAD COMBINATION 1 - - - -

MOMENT (KF) = 858.6 MOMENT STRENGTH (KF) = 2423.5
THRUST (K) = 826.8 AXIAL STRENGTH (K) = 1725.3
COMBINED BENDING FACTOR = .81
FATIGUE STRESS RANGE (KSI) = 8.06

SHEAR (K) = 216.8 SHEAR STRENGTH = 313.7

- - - - LOAD COMBINATION 2 - - - -

MOMENT (KF) = 883.3 MOMENT STRENGTH (KF) = 2423.5
THRUST (K) = 850.6 AXIAL STRENGTH (K) = 1725.3
COMBINED BENDING FACTOR = .83
FATIGUE STRESS RANGE (KSI) = 8.06

SHEAR (K) = 223.0 SHEAR STRENGTH = 313.7

- - - - LOAD COMBINATION 4 - - - -

MOMENT (KF)= 24.7 MOMENT STRENGTH (KF)= 2423.5
 THRUST (K) = 23.8 AXIAL STRENGTH (K)= 1725.3
 COMBINED BENDING FACTOR= .02
 FATIGUE STRESS RANGE (KSI)= 8.06

SHEAR (K)= 6.2 SHEAR STRENGTH= 313.7

- - - - LOAD COMBINATION 5 - - - -

MOMENT (KF)= 11.4 MOMENT STRENGTH (KF)= 2423.5
 THRUST (K) = 11.0 AXIAL STRENGTH (K)= 1725.3
 COMBINED BENDING FACTOR= .01
 FATIGUE STRESS RANGE (KSI)= 8.06

SHEAR (K)= 2.9 SHEAR STRENGTH= 313.7

- - - - LOAD COMBINATION 6 - - - -

MOMENT (KF)= 780.4 MOMENT STRENGTH (KF)= 2423.5
 THRUST (K) = 751.5 AXIAL STRENGTH (K)= 1725.3
 COMBINED BENDING FACTOR= .73
 FATIGUE STRESS RANGE (KSI)= 8.06

SHEAR (K)= 197.0 SHEAR STRENGTH= 313.7

----- GIRDER 10 -----

WEB DEPTH (IN)		WEB THICKNESS (IN)					
50.000		.500					
UPSTREAM							
FLANGE PT.3-4	FLANGE PT.4-CL	COVER PLATE	SPLICE PT.	COVER PLATE			
WIDTH THICK.	WIDTH THICK.	WIDTH THICK.	DIST. (IN)	DIST. (IN)			
12.00 .500	12.00 .500	.00 .000	49.5	.0			
DOWNSTREAM							
FLANGE PT.1-5	FLANGE PT.5-CL	COVER PLATE	SPLICE PT.	COVER PLATE			
WIDTH THICK.	WIDTH THICK.	WIDTH THICK.	DIST. (IN)	DIST. (IN)			
12.00 .500	12.00 .500	.00 .000	49.5	.0			
NO.OF TRANSVERSE STIFF. BETWEEN ADJ. DIAPH. 0							

LONGITUDINAL STIFFENERS

NO.		DIST.FROM DS.FL.(IN)	WIDTH (IN)	THICKNESS (IN)
1	BOTH SIDES	16.5	5.50	.500
2	BOTH SIDES	33.0	5.50	.500

EFFECTIVE WEB DEPTH (IN) 50.000

SECTION-	CENTER LINE	LEFT SIDE	
IX 22329. IN**4	IY 2216. IN**4	RX 18.39 IN	RY 5.79 IN
	KL/RX 31.5	KL/RY 13.5	

GIRDER AREA 66.00IN**2

- - - - LOAD COMBINATION 1 - - - -

MOMENT (KF)= 1308.9 MOMENT STRENGTH(KF)= 2571.0
 THRUST (K) = 826.8 AXIAL STRENGTH(K)= 1725.3
 COMBINED BENDING FACTOR= .95
 FATIGUE STRESS RANGE (KSI)= 9.74

SHEAR (K)= 216.8 SHEAR STRENGTH= 313.7

- - - - LOAD COMBINATION 2 - - - -

MOMENT (KF)= 1346.6 MOMENT STRENGTH(KF)= 2571.0
 THRUST (K) = 850.6 AXIAL STRENGTH(K)= 1725.3
 COMBINED BENDING FACTOR= .98
 FATIGUE STRESS RANGE (KSI)= 9.74

SHEAR (K)= 223.0 SHEAR STRENGTH= 313.7

- - - - LOAD COMBINATION 4 - - - -

MOMENT (KF)= 37.7 MOMENT STRENGTH(KF)= 2571.0
 THRUST (K) = 23.8 AXIAL STRENGTH(K)= 1725.3
 COMBINED BENDING FACTOR= .02
 FATIGUE STRESS RANGE (KSI)= 9.74

SHEAR (K)= 6.2 SHEAR STRENGTH= 313.7

- - - - LOAD COMBINATION 5 - - - -

MOMENT (KF) = 17.4 MOMENT STRENGTH (KF) = 2571.0
THRUST (K) = 11.0 AXIAL STRENGTH (K) = 1725.3
COMBINED BENDING FACTOR = .01
FATIGUE STRESS RANGE (KSI) = 9.74

SHEAR (K) = 2.9 SHEAR STRENGTH = 313.7

- - - - LOAD COMBINATION 6 - - - -

MOMENT (KF) = 1197.1 MOMENT STRENGTH (KF) = 2571.0
THRUST (K) = 756.2 AXIAL STRENGTH (K) = 1725.3
COMBINED BENDING FACTOR = .87
FATIGUE STRESS RANGE (KSI) = 9.74

SHEAR (K) = 198.2 SHEAR STRENGTH = 313.7

SECTION- END DIAPHRAGM RIGHT SIDE
IX 22329. IN**4 IY 2216. IN**4 RX 18.39 IN RY 5.79 IN
KL/RX 31.5 KL/RY 13.5

GIRDER AREA 66.00IN**2

- - - - LOAD COMBINATION 1 - - - -

MOMENT (KF) = 858.6 MOMENT STRENGTH (KF) = 2423.5
THRUST (K) = 826.8 AXIAL STRENGTH (K) = 1725.3
COMBINED BENDING FACTOR = .81
FATIGUE STRESS RANGE (KSI) = 8.06

SHEAR (K) = 216.8 SHEAR STRENGTH = 313.7

- - - - LOAD COMBINATION 2 - - - -

MOMENT (KF) = 883.3 MOMENT STRENGTH (KF) = 2423.5
THRUST (K) = 850.6 AXIAL STRENGTH (K) = 1725.3
COMBINED BENDING FACTOR = .83
FATIGUE STRESS RANGE (KSI) = 8.06

SHEAR (K) = 223.0 SHEAR STRENGTH = 313.7

- - - - LOAD COMBINATION 4 - - - -

MOMENT (KF) = 24.7 MOMENT STRENGTH (KF) = 2423.5
 THRUST (K) = 23.8 AXIAL STRENGTH (K) = 1725.3
 COMBINED BENDING FACTOR = .02
 FATIGUE STRESS RANGE (KSI) = 8.06

SHEAR (K) = 6.2 SHEAR STRENGTH = 313.7

- - - - LOAD COMBINATION 5 - - - -

MOMENT (KF) = 11.4 MOMENT STRENGTH (KF) = 2423.5
 THRUST (K) = 11.0 AXIAL STRENGTH (K) = 1725.3
 COMBINED BENDING FACTOR = .01
 FATIGUE STRESS RANGE (KSI) = 8.06

SHEAR (K) = 2.9 SHEAR STRENGTH = 313.7

- - - - LOAD COMBINATION 6 - - - -

MOMENT (KF) = 785.2 MOMENT STRENGTH (KF) = 2423.5
 THRUST (K) = 756.2 AXIAL STRENGTH (K) = 1725.3
 COMBINED BENDING FACTOR = .74
 FATIGUE STRESS RANGE (KSI) = 8.06

SHEAR (K) = 198.2 SHEAR STRENGTH = 313.7

----- GIRDER 11 -----

WEB DEPTH (IN)		WEB THICKNESS (IN)					
50.000		.500					
UPSTREAM							
FLANGE PT. 3-4	FLANGE PT. 4-CL	COVER PLATE	SPLICE PT.	COVER PLATE			
WIDTH THICK.	WIDTH THICK.	WIDTH THICK.	DIST. (IN)	DIST. (IN)			
12.00 .500	12.00 .500	.00 .000	49.5	.0			
DOWNSTREAM							
FLANGE PT. 1-5	FLANGE PT. 5-CL	COVER PLATE	SPLICE PT.	COVER PLATE			
WIDTH THICK.	WIDTH THICK.	WIDTH THICK.	DIST. (IN)	DIST. (IN)			
12.00 .500	12.00 .500	.00 .000	49.5	.0			
NO. OF TRANSVERSE STIFF. BETWEEN ADJ. DIAPH. 0							

LONGITUDINAL STIFFENERS

NO.		DIST.FROM DS.FL. (IN)	WIDTH (IN)	THICKNESS (IN)
1	BOTH SIDES	16.5	5.50	.500
2	BOTH SIDES	33.0	5.50	.500

EFFECTIVE WEB DEPTH (IN) 50.000

	SECTION-	CENTER LINE	LEFT SIDE
IX 22329.	IN**4	IY 2216.	IN**4 RX 18.39 IN RY 5.79 IN
	KL/RX	31.5	KL/RX 13.5

GIRDER AREA 66.00IN**2

- - - - LOAD COMBINATION 1 - - - -

MOMENT(KF)= 1308.9 MOMENT STRENGTH(KF)= 2571.0
 THRUST(K) = 826.8 AXIAL STRENGTH(K)= 1725.3
 COMBINED BENDING FACTOR= .95
 FATIGUE STRESS RANGE(KSI)= 9.74

SHEAR(K)= 216.8 SHEAR STRENGTH= 313.7

- - - - LOAD COMBINATION 2 - - - -

MOMENT(KF)= 1346.6 MOMENT STRENGTH(KF)= 2571.0
 THRUST(K) = 850.6 AXIAL STRENGTH(K)= 1725.3
 COMBINED BENDING FACTOR= .98
 FATIGUE STRESS RANGE(KSI)= 9.74

SHEAR(K)= 223.0 SHEAR STRENGTH= 313.7

- - - - LOAD COMBINATION 4 - - - -

MOMENT(KF)= 37.7 MOMENT STRENGTH(KF)= 2571.0
 THRUST(K) = 23.8 AXIAL STRENGTH(K)= 1725.3
 COMBINED BENDING FACTOR= .02
 FATIGUE STRESS RANGE(KSI)= 9.74

SHEAR(K)= 6.2 SHEAR STRENGTH= 313.7

- - - - LOAD COMBINATION 5 - - - -

MOMENT (KF)= 17.4 MOMENT STRENGTH (KF)= 2571.0
THRUST (K) = 11.0 AXIAL STRENGTH (K)= 1725.3
COMBINED BENDING FACTOR= .01
FATIGUE STRESS RANGE (KSI)= 9.74

SHEAR (K)= 2.9 SHEAR STRENGTH= 313.7

- - - - LOAD COMBINATION 6 - - - -

MOMENT (KF)= 1203.4 MOMENT STRENGTH (KF)= 2571.0
THRUST (K) = 760.1 AXIAL STRENGTH (K)= 1725.3
COMBINED BENDING FACTOR= .87
FATIGUE STRESS RANGE (KSI)= 9.74

SHEAR (K)= 199.3 SHEAR STRENGTH= 313.7

SECTION- END DIAPHRAGM RIGHT SIDE
IX 22329. IN**4 IY 2216. IN**4 RX 18.39 IN RY 5.79 IN
 KL/RX 31.5 KL/RY 13.5

GIRDER AREA 66.00IN**2

- - - - LOAD COMBINATION 1 - - - -

MOMENT (KF)= 858.6 MOMENT STRENGTH (KF)= 2423.5
THRUST (K) = 826.8 AXIAL STRENGTH (K)= 1725.3
COMBINED BENDING FACTOR= .81
FATIGUE STRESS RANGE (KSI)= 8.06

SHEAR (K)= 216.8 SHEAR STRENGTH= 313.7

- - - - LOAD COMBINATION 2 - - - -

MOMENT (KF)= 883.3 MOMENT STRENGTH (KF)= 2423.5
THRUST (K) = 850.6 AXIAL STRENGTH (K)= 1725.3
COMBINED BENDING FACTOR= .83
FATIGUE STRESS RANGE (KSI)= 8.06

SHEAR (K)= 223.0 SHEAR STRENGTH= 313.7

- - - - LOAD COMBINATION 4 - - - -

MOMENT (KF) = 24.7 MOMENT STRENGTH (KF) = 2423.5
 THRUST (K) = 23.8 AXIAL STRENGTH (K) = 1725.3
 COMBINED BENDING FACTOR = .02
 FATIGUE STRESS RANGE (KSI) = 8.06

SHEAR (K) = 6.2 SHEAR STRENGTH = 313.7

- - - - LOAD COMBINATION 5 - - - -

MOMENT (KF) = 11.4 MOMENT STRENGTH (KF) = 2423.5
 THRUST (K) = 11.0 AXIAL STRENGTH (K) = 1725.3
 COMBINED BENDING FACTOR = .01
 FATIGUE STRESS RANGE (KSI) = 8.06

SHEAR (K) = 2.9 SHEAR STRENGTH = 313.7

- - - - LOAD COMBINATION 6 - - - -

MOMENT (KF) = 789.3 MOMENT STRENGTH (KF) = 2423.5
 THRUST (K) = 760.1 AXIAL STRENGTH (K) = 1725.3
 COMBINED BENDING FACTOR = .74
 FATIGUE STRESS RANGE (KSI) = 8.06

SHEAR (K) = 199.3 SHEAR STRENGTH = 313.7

----- GIRDER 12 -----

WEB DEPTH (IN)		WEB THICKNESS (IN)					
50.000		.500					
UPSTREAM							
FLANGE PT. 3-4	FLANGE PT. 4-CL	COVER PLATE	SPLICE PT.	COVER PLATE			
WIDTH	THICK.	WIDTH	THICK.	WIDTH	THICK.	DIST. (IN)	DIST. (IN)
12.00	.500	12.00	.500	.00	.000	49.5	.0
DOWNSTREAM							
FLANGE PT. 1-5	FLANGE PT. 5-CL	COVER PLATE	SPLICE PT.	COVER PLATE			
WIDTH	THICK.	WIDTH	THICK.	WIDTH	THICK.	DIST. (IN)	DIST. (IN)
10.50	.500	9.00	.500	.00	.000	61.5	.0
NO. OF TRANSVERSE STIFF. BETWEEN ADJ. DIAPH.						0	

LONGITUDINAL STIFFENERS

NO.		DIST.FROM DS.FL. (IN)	WIDTH (IN)	THICKNESS (IN)
1	BOTH SIDES	16.5	5.50	.500
2	BOTH SIDES	33.0	5.50	.500

EFFECTIVE WEB DEPTH (IN) 50.000

SECTION- CENTER LINE LEFT SIDE
 IX 18974. IN**4 IY 1211. IN**4 RX 17.86 IN RY 4.51 IN
 KL/RX 32.4 KL/RY 17.3

GIRDER AREA 59.50IN**2

- - - - LOAD COMBINATION 1 - - - -

MOMENT (KF)= 1021.2 MOMENT STRENGTH(KF)= 2235.2
 THRUST (K) = 620.1 AXIAL STRENGTH(K)= 1550.4
 COMBINED BENDING FACTOR= .82
 FATIGUE STRESS RANGE(KSI)= 8.20

SHEAR (K)= 162.6 SHEAR STRENGTH= 313.7

- - - - LOAD COMBINATION 2 - - - -

MOMENT (KF)= 1050.6 MOMENT STRENGTH(KF)= 2235.2
 THRUST (K) = 638.0 AXIAL STRENGTH(K)= 1550.4
 COMBINED BENDING FACTOR= .85
 FATIGUE STRESS RANGE(KSI)= 8.20

SHEAR (K)= 167.2 SHEAR STRENGTH= 313.7

- - - - LOAD COMBINATION 4 - - - -

MOMENT (KF)= 29.4 MOMENT STRENGTH(KF)= 2235.2
 THRUST (K) = 17.9 AXIAL STRENGTH(K)= 1550.4
 COMBINED BENDING FACTOR= .02
 FATIGUE STRESS RANGE(KSI)= 8.20

SHEAR (K)= 4.7 SHEAR STRENGTH= 313.7

- - - - LOAD COMBINATION 5 - - - -

MOMENT(KF)= 13.6 MOMENT STRENGTH(KF)= 2235.2
THRUST(K) = 8.2 AXIAL STRENGTH(K)= 1550.4
COMBINED BENDING FACTOR= .01
FATIGUE STRESS RANGE(KSI)= 8.20

SHEAR(K)= 2.2 SHEAR STRENGTH= 313.7

- - - - LOAD COMBINATION 6 - - - -

MOMENT(KF)= 942.7 MOMENT STRENGTH(KF)= 2235.2
THRUST(K) = 572.4 AXIAL STRENGTH(K)= 1550.4
COMBINED BENDING FACTOR= .76
FATIGUE STRESS RANGE(KSI)= 8.20

SHEAR(K)= 150.1 SHEAR STRENGTH= 313.7

SECTION- DS FLNG SPLICE RIGHT SIDE
IX 18974. IN**4 IY 1211. IN**4 RX 17.86 IN RY 4.51 IN
KL/RX 32.4 KL/RX 17.3

GIRDER AREA 59.50IN**2

- - - - LOAD COMBINATION 1 - - - -

MOMENT(KF)= 445.9 MOMENT STRENGTH(KF)= 2235.2
THRUST(K) = 620.1 AXIAL STRENGTH(K)= 1550.4
COMBINED BENDING FACTOR= .58
FATIGUE STRESS RANGE(KSI)= 6.91

SHEAR(K)= 162.6 SHEAR STRENGTH= 313.7

- - - - LOAD COMBINATION 2 - - - -

MOMENT(KF)= 458.7 MOMENT STRENGTH(KF)= 2235.2
THRUST(K) = 638.0 AXIAL STRENGTH(K)= 1550.4
COMBINED BENDING FACTOR= .60
FATIGUE STRESS RANGE(KSI)= 6.91

SHEAR(K)= 167.2 SHEAR STRENGTH= 313.7

- - - - LOAD COMBINATION 4 - - - -

MOMENT (KF)= 12.8 MOMENT STRENGTH(KF)= 2235.2
THRUST (K) = 17.9 AXIAL STRENGTH(K)= 1550.4
COMBINED BENDING FACTOR= .01
FATIGUE STRESS RANGE(KSI)= 6.91

SHEAR (K)= 4.7 SHEAR STRENGTH= 313.7

- - - - LOAD COMBINATION 5 - - - -

MOMENT (KF)= 5.9 MOMENT STRENGTH(KF)= 2235.2
THRUST (K) = 8.2 AXIAL STRENGTH(K)= 1550.4
COMBINED BENDING FACTOR= .01
FATIGUE STRESS RANGE(KSI)= 6.91

SHEAR (K)= 2.2 SHEAR STRENGTH= 313.7

- - - - LOAD COMBINATION 6 - - - -

MOMENT (KF)= 411.6 MOMENT STRENGTH(KF)= 2235.2
THRUST (K) = 572.4 AXIAL STRENGTH(K)= 1550.4
COMBINED BENDING FACTOR= .54
FATIGUE STRESS RANGE(KSI)= 6.91

SHEAR (K)= 150.1 SHEAR STRENGTH= 313.7

SECTION- DS FLNG SPLICE LEFT SIDE

IX 19707. IN**4 IY 1234. IN**4 RX 18.09 IN RY 4.53 IN
KL/RX 32.0 KL/RY 17.2

GIRDER AREA 60.25IN**2

- - - - LOAD COMBINATION 1 - - - -

MOMENT (KF)= 425.7 MOMENT STRENGTH(KF)= 2295.8
THRUST (K) = 620.1 AXIAL STRENGTH(K)= 1572.2
COMBINED BENDING FACTOR= .57
FATIGUE STRESS RANGE(KSI)= 6.87

SHEAR (K)= 162.6 SHEAR STRENGTH= 313.7

- - - - LOAD COMBINATION 2 - - - -

MOMENT(KF)= 437.9 MOMENT STRENGTH(KF)= 2295.8
THRUST(K) = 638.0 AXIAL STRENGTH(K)= 1572.2
COMBINED BENDING FACTOR= .58
FATIGUE STRESS RANGE(KSI)= 6.87

SHEAR(K)= 167.2 SHEAR STRENGTH= 313.7

- - - - LOAD COMBINATION 4 - - - -

MOMENT(KF)= 12.3 MOMENT STRENGTH(KF)= 2295.8
THRUST(K) = 17.9 AXIAL STRENGTH(K)= 1572.2
COMBINED BENDING FACTOR= .01
FATIGUE STRESS RANGE(KSI)= 6.87

SHEAR(K)= 4.7 SHEAR STRENGTH= 313.7

- - - - LOAD COMBINATION 5 - - - -

MOMENT(KF)= 5.7 MOMENT STRENGTH(KF)= 2295.8
THRUST(K) = 8.2 AXIAL STRENGTH(K)= 1572.2
COMBINED BENDING FACTOR= .01
FATIGUE STRESS RANGE(KSI)= 6.87

SHEAR(K)= 2.2 SHEAR STRENGTH= 313.7

- - - - LOAD COMBINATION 6 - - - -

MOMENT(KF)= 392.9 MOMENT STRENGTH(KF)= 2295.8
THRUST(K) = 572.4 AXIAL STRENGTH(K)= 1572.2
COMBINED BENDING FACTOR= .52
FATIGUE STRESS RANGE(KSI)= 6.87

SHEAR(K)= 150.1 SHEAR STRENGTH= 313.7

SECTION- END DIAPHRAGM RIGHT SIDE
IX 19707. IN**4 IY 1234. IN**4 RX 18.09 IN RY 4.53 IN
KL/RX 32.0 KL/RY 17.2

GIRDER AREA 60.25IN**2

- - - - LOAD COMBINATION 1 - - - -

MOMENT (KF) = 584.2 MOMENT STRENGTH (KF) = 2295.8
THRUST (K) = 620.1 AXIAL STRENGTH (K) = 1572.2
COMBINED BENDING FACTOR = .63
FATIGUE STRESS RANGE (KSI) = 6.69

SHEAR (K) = 162.6 SHEAR STRENGTH = 313.7

- - - - LOAD COMBINATION 2 - - - -

MOMENT (KF) = 601.0 MOMENT STRENGTH (KF) = 2295.8
THRUST (K) = 638.0 AXIAL STRENGTH (K) = 1572.2
COMBINED BENDING FACTOR = .65
FATIGUE STRESS RANGE (KSI) = 6.69

SHEAR (K) = 167.2 SHEAR STRENGTH = 313.7

- - - - LOAD COMBINATION 4 - - - -

MOMENT (KF) = 16.8 MOMENT STRENGTH (KF) = 2295.8
THRUST (K) = 17.9 AXIAL STRENGTH (K) = 1572.2
COMBINED BENDING FACTOR = .01
FATIGUE STRESS RANGE (KSI) = 6.69

SHEAR (K) = 4.7 SHEAR STRENGTH = 313.7

- - - - LOAD COMBINATION 5 - - - -

MOMENT (KF) = 7.8 MOMENT STRENGTH (KF) = 2295.8
THRUST (K) = 8.2 AXIAL STRENGTH (K) = 1572.2
COMBINED BENDING FACTOR = .01
FATIGUE STRESS RANGE (KSI) = 6.69

SHEAR (K) = 2.2 SHEAR STRENGTH = 313.7

- - - - LOAD COMBINATION 6 - - - -

MOMENT (KF) = 539.3 MOMENT STRENGTH (KF) = 2295.8
THRUST (K) = 572.4 AXIAL STRENGTH (K) = 1572.2
COMBINED BENDING FACTOR = .58
FATIGUE STRESS RANGE (KSI) = 6.69

SHEAR (K) = 150.1 SHEAR STRENGTH = 313.7

END DIAPHRAGM INVESTIGATION

END DIAPHRAGM THICKNESS (IN)	UPSTREAM FLANGE WIDTH (IN)	UPSTREAM FLANGE THICKNESS (IN)	DOWNSTREAM FLANGE WIDTH (IN)	DOWNSTREAM FLANGE THICKNESS (IN)
.750	4.00	SAME AS U.S. GIRDER (GUFCT)	4.00	.500

LOAD COMBINATION 1

PANEL STRENGTH= 36.0 KSI
 MAX. DEFLECTION= .30000IN
 ALLOWABLE STRESS RANGE= 21.0 KSI

PANEL NO.	STRESS (KSI)	DEFLECTION (IN)	FAT. STRESS RANGE (KSI)
1	.00	.00000	.00
2	2.89	.00377	1.67
3	4.67	.00609	2.70
4	8.09	.01054	4.68
5	11.56	.01506	6.69
6	14.65	.01886	8.48
7	16.75	.02084	9.69
8	17.39	.02163	10.06
9	17.39	.02163	10.06
10	17.39	.02163	10.06
11	17.39	.02163	10.06

LOAD COMBINATION 2

PANEL STRENGTH= 36.0 KSI
 MAX. DEFLECTION= .30000IN
 ALLOWABLE STRESS RANGE= 21.0 KSI

PANEL NO.	STRESS (KSI)	DEFLECTION (IN)	FAT. STRESS RANGE (KSI)
1	.52	.00000	.00
2	1.72	.00377	1.67
3	5.14	.00609	2.70
4	8.61	.01054	4.68
5	12.07	.01506	6.69
6	15.17	.01886	8.48
7	17.26	.02084	9.69
8	17.89	.02163	10.06
9	17.89	.02163	10.06
10	17.89	.02163	10.06
11	17.89	.02163	10.06

LOAD COMBINATION 4

PANEL STRENGTH= 36.0 KSI
 MAX. DEFLECTION= .30000IN
 ALLOWABLE STRESS RANGE= 21.0 KSI

PANEL NO.	STRESS (KSI)	DEFLECTION (IN)	FAT. STRESS RANGE (KSI)
1	.52	.00000	.00
2	.52	.00377	1.67
3	.52	.00609	2.70
4	.52	.01054	4.68
5	.52	.01506	6.69
6	.51	.01886	8.48
7	.50	.02084	9.69
8	.50	.02163	10.06
9	.50	.02163	10.06
10	.50	.02163	10.06
11	.50	.02163	10.06

LOAD COMBINATION 5

PANEL STRENGTH= 36.0 KSI
 MAX. DEFLECTION= .30000IN
 ALLOWABLE STRESS RANGE= 21.0 KSI

PANEL NO.	STRESS (KSI)	DEFLECTION (IN)	FAT. STRESS RANGE (KSI)
1	.00	.00000	.00
2	.20	.00377	1.67
3	.24	.00609	2.70
4	.24	.01054	4.68
5	.24	.01506	6.69
6	.24	.01886	8.48
7	.23	.02084	9.69
8	.23	.02163	10.06
9	.23	.02163	10.06
10	.23	.02163	10.06
11	.23	.02163	10.06

LOAD COMBINATION 6

PANEL STRENGTH= 36.0 KSI
 MAX. DEFLECTION= .30000IN
 ALLOWABLE STRESS RANGE= 21.0 KSI

PANEL NO.	STRESS (KSI)	DEFLECTION (IN)	FAT. STRESS RANGE (KSI)
1	.00	.00000	.00
2	1.19	.00377	1.67
3	4.32	.00609	2.70
4	7.41	.01054	4.68
5	10.47	.01506	6.69
6	13.19	.01886	8.48
7	15.04	.02084	9.69
8	15.74	.02163	10.06
9	15.85	.02163	10.06
10	15.94	.02163	10.06
11	16.02	.02163	10.06

QUOIN POST INVESTIGATION

POSITIVE STRESSES ARE IN COMPRESION

QUOIN CONTACT PLATE
DIMENSIONS (IN)

U.S. PARTIAL WIDTH INPUT	U.S. WIDTH	D.S. WIDTH	THICK	STIFFENER WIDTH	THICK
11.000	11.527	7.076	1.000	6.000	.500

THRUST DIAPHRAGM
DIMENSIONS (IN)

DIAPHRAGM THICK	STIF.WEB THICK	STIF.FLNG THICK	STIF.FLNG U.S.	WIDTH D.S.
1.000	1.000	.500	6.000	6.000

QUOIN POST PROPERTIES (IN.)

AREA SQ. IN.	CENTROID		MOMENT OF INERTIA	
	X-DIR	Y-DIR	IX	IY
103.52	23.89	1.39	6176.09	14691.10

QUOIN POST STRESSES (KSI)

-PT. A-	-PT. B-	-PT. C-	-PT. D-	-PT. E-	-PT. F-
10.33	-.84	20.18	-1.74	3.87	5.75

POSITIVE STRESSES ARE IN COMPRESION

QUOIN CONTACT PLATE
DIMENSIONS (IN)

U.S. PARTIAL WIDTH INPUT	U.S. WIDTH	D.S. WIDTH	THICK	STIFFENER WIDTH	THICK
11.000	11.527	7.076	1.000	6.000	.500

THRUST DIAPHRAGM
DIMENSIONS (IN)

DIAPHRAGM THICK	STIF.WEB THICK	STIF.FLNG THICK	STIF.FLNG U.S.	WIDTH D.S.
1.000	1.000	.500	6.000	6.000

QUOIN POST PROPERTIES (IN.)

AREA SQ. IN.	CENTROID		MOMENT OF INERTIA	
	X-DIR	Y-DIR	IX	IY
103.52	23.89	1.39	6176.09	14691.10

QUOIN POST STRESSES (KSI)

-PT. A-	-PT. B-	-PT. C-	-PT. D-	-PT. E-	-PT. F-
10.33	-.84	20.18	-1.74	3.87	5.75

POSITIVE STRESSES ARE IN COMPRESION

QUOIN CONTACT PLATE
DIMENSIONS (IN)

U.S. PARTIAL WIDTH INPUT	U.S. WIDTH	D.S. WIDTH	THICK	STIFFENER WIDTH	THICK
11.000	11.527	7.076	1.000	6.000	.500

THRUST DIAPHRAGM

DIMENSIONS (IN)

DIAPHRAGM THICK	STIF.WEB THICK	STIF.FLNG THICK	STIF.FLNG U.S.	WIDTH D.S.
1.000	1.000	.500	6.000	6.000

QUOIN POST PROPERTIES (IN.)

AREA SQ. IN.	CENTROID		MOMENT OF INERTIA	
	X-DIR	Y-DIR	IX	IY
103.52	23.89	1.39	6176.09	14691.10

QUOIN POST STRESSES (KSI)

-PT. A-	-PT. B-	-PT. C-	-PT. D-	-PT. E-	-PT. F-
10.33	-.84	20.18	-1.74	3.87	5.75

POSITIVE STRESSES ARE IN COMPRESION

QUOIN CONTACT PLATE

DIMENSIONS (IN)

U.S. PARTIAL WIDTH	U.S. INPUT WIDTH	D.S. WIDTH	THICK	STIFFENER WIDTH	THICK
11.000	11.527	7.076	1.000	6.000	.500

THRUST DIAPHRAGM

DIMENSIONS (IN)

DIAPHRAGM THICK	STIF.WEB THICK	STIF.FLNG THICK	STIF.FLNG U.S.	WIDTH D.S.
1.000	1.000	.500	6.000	6.000

QUOIN POST PROPERTIES (IN.)

AREA SQ. IN.	CENTROID		MOMENT OF INERTIA	
	X-DIR	Y-DIR	IX	IY
103.52	23.89	1.39	6176.09	14691.10

QUOIN POST STRESSES (KSI)

-PT. A-	-PT. B-	-PT. C-	-PT. D-	-PT. E-	-PT. F-
10.33	-.84	20.18	-1.74	3.87	5.75

POSITIVE STRESSES ARE IN COMPRESION

QUOIN CONTACT PLATE
DIMENSIONS (IN)

U.S. PARTIAL WIDTH INPUT	U.S. WIDTH	D.S. WIDTH	THICK	STIFFENER WIDTH	THICK
11.000	11.527	7.076	1.000	6.000	.500

THRUST DIAPHRAGM
DIMENSIONS (IN)

DIAPHRAGM THICK	STIF.WEB THICK	STIF.FLNG THICK	STIF.FLNG U.S.	WIDTH D.S.
1.000	1.000	.500	6.000	6.000

QUOIN POST PROPERTIES (IN.)

AREA SQ. IN.	CENTROID		MOMENT OF INERTIA	
	X-DIR	Y-DIR	IX	IY
103.52	23.89	1.39	6176.09	14691.10

QUOIN POST STRESSES (KSI)

-PT. A-	-PT. B-	-PT. C-	-PT. D-	-PT. E-	-PT. F-
10.33	-.84	20.18	-1.74	3.87	5.75

THRUST DIAPHRAGM INVESTIGATION

THRUST DIAPHRAGM THICKNESS= 1.000 IN
 THRUST DIAPHRAGM STIFFENER AREA= .000 IN**2
 INTERIOR PANEL WIDTH= 2.000 FT
 EXTERIOR PANEL WIDTH= 1.765 FT

LOAD COMBINATION 1

STRENGTH= 36.0 KSI
 SHEAR STRENGTH 36.0 KSI
 MAX. DEFLECTION= .40000 IN
 ALL. STRESS RANGE 21.0 KSI

PANEL NO.	PANEL HEIGHT (FT)	BENDING STRESS (KSI)	DEFLECTION (IN)	STRESS RANGE (KSI)	HORIZONTAL SHEAR (KSI)
EXT 1	6.000	.000	.00000	.000	.000
INT		.000	.00000	.000	.000
EXT 2	6.000	4.710	.00070	2.608	2.733
INT		.840	.00043	.486	2.733
EXT 3	6.000	7.614	.00113	4.217	4.419
INT		1.358	.00069	.786	4.419
EXT 4	6.000	13.187	.00196	7.303	7.653
INT		2.351	.00119	1.360	7.653
EXT 5	6.000	18.839	.00280	10.433	10.932
INT		3.359	.00170	1.944	10.932
EXT 6	5.000	24.010	.00355	13.296	11.616
INT		4.280	.00217	2.476	11.616

EXT		28.084	.00407	15.551	10.887
7	4.000				
INT		4.997	.00251	2.891	10.887
EXT		29.141	.00423	16.137	11.297
8	4.000				
INT		5.185	.00260	3.000	11.297
EXT		29.141	.00423	16.137	11.297
9	4.000				
INT		5.185	.00260	3.000	11.297
EXT		29.141	.00423	16.137	11.297
10	4.000				
INT		5.185	.00260	3.000	11.297
EXT		29.141	.00423	16.137	11.297
11	4.000				
INT		5.185	.00260	3.000	11.297

LOAD COMBINATION 2

STRENGTH= 36.0 KSI
 SHEAR STRENGTH 36.0 KSI
 MAX. DEFLECTION= .40000 IN
 ALL. STRESS RANGE 21.0 KSI

PANEL NO.	PANEL HEIGHT (FT)	BENDING STRESS (KSI)	DEFLECTION (IN)	STRESS RANGE (KSI)	HORIZONTAL SHEAR (KSI)
EXT 1	6.000	.841	.00000	.000	.488
INT		.150	.00000	.000	.488
EXT 2	6.000	2.803	.00070	2.608	1.627
INT		.500	.00043	.486	1.627
EXT 3	6.000	8.377	.00113	4.217	4.861
INT		1.494	.00069	.786	4.861
EXT 4	6.000	14.028	.00196	7.303	8.141
INT		2.501	.00119	1.360	8.141

EXT		19.680	.00280	10.433	11.421
5	6.000				
INT		3.509	.00170	1.944	11.421
EXT		24.851	.00355	13.296	12.022
6	5.000				
INT		4.429	.00217	2.476	12.022
EXT		28.923	.00407	15.551	11.212
7	4.000				
INT		5.146	.00251	2.891	11.212
EXT		29.981	.00423	16.137	11.622
8	4.000				
INT		5.334	.00260	3.000	11.622
EXT		29.981	.00423	16.137	11.622
9	4.000				
INT		5.334	.00260	3.000	11.622
EXT		29.981	.00423	16.137	11.622
10	4.000				
INT		5.334	.00260	3.000	11.622
EXT		29.981	.00423	16.137	11.622
11	4.000				
INT		5.334	.00260	3.000	11.622

LOAD COMBINATION 4

STRENGTH= 36.0 KSI
 SHEAR STRENGTH 36.0 KSI
 MAX. DEFLECTION= .40000 IN
 ALL. STRESS RANGE 21.0 KSI

PANEL NO.	PANEL HEIGHT (FT)	BENDING STRESS (KSI)	DEFLECTION (IN)	STRESS RANGE (KSI)	HORIZONTAL SHEAR (KSI)
EXT 1	6.000	.841	.00000	.000	.488
INT		.150	.00000	.000	.488
EXT 2	6.000	.841	.00070	2.608	.488
INT		.150	.00043	.486	.488

EXT		.841	.00113	4.217	.488
3	6.000				
INT		.150	.00069	.786	.488
EXT		.841	.00196	7.303	.488
4	6.000				
INT		.150	.00119	1.360	.488
EXT		.841	.00280	10.433	.488
5	6.000				
INT		.150	.00170	1.944	.488
EXT		.841	.00355	13.296	.407
6	5.000				
INT		.150	.00217	2.476	.407
EXT		.839	.00407	15.551	.325
7	4.000				
INT		.149	.00251	2.891	.325
EXT		.839	.00423	16.137	.325
8	4.000				
INT		.149	.00260	3.000	.325
EXT		.839	.00423	16.137	.325
9	4.000				
INT		.149	.00260	3.000	.325
EXT		.839	.00423	16.137	.325
10	4.000				
INT		.149	.00260	3.000	.325
EXT		.839	.00423	16.137	.325
11	4.000				
INT		.149	.00260	3.000	.325

LOAD COMBINATION 5

STRENGTH= 36.0 KSI
 SHEAR STRENGTH 36.0 KSI
 MAX. DEFLECTION= .40000 IN
 ALL. STRESS RANGE 21.0 KSI

PANEL NO.	PANEL HEIGHT (FT)	BENDING STRESS (KSI)	DEFLECTION (IN)	STRESS RANGE (KSI)	HORIZONTAL SHEAR (KSI)
EXT 1	6.000	.000	.00000	.000	.000
INT		.000	.00000	.000	.000
EXT 2	6.000	.323	.00070	2.608	.188
INT		.058	.00043	.486	.188
EXT 3	6.000	.388	.00113	4.217	.225
INT		.069	.00069	.786	.225
EXT 4	6.000	.388	.00196	7.303	.225
INT		.069	.00119	1.360	.225
EXT 5	6.000	.388	.00280	10.433	.225
INT		.069	.00170	1.944	.225
EXT 6	5.000	.388	.00355	13.296	.188
INT		.069	.00217	2.476	.188
EXT 7	4.000	.387	.00407	15.551	.150
INT		.069	.00251	2.891	.150
EXT 8	4.000	.387	.00423	16.137	.150
INT		.069	.00260	3.000	.150
EXT 9	4.000	.387	.00423	16.137	.150
INT		.069	.00260	3.000	.150

EXT		.387	.00423	16.137	.150
10	4.000				
INT		.069	.00260	3.000	.150
EXT		.387	.00423	16.137	.150
11	4.000				
INT		.069	.00260	3.000	.150

LOAD COMBINATION 6

STRENGTH= 36.0 KSI
 SHEAR STRENGTH 36.0 KSI
 MAX. DEFLECTION= .40000 IN
 ALL. STRESS RANGE 21.0 KSI

PANEL NO.	PANEL HEIGHT (FT)	BENDING STRESS (KSI)	DEFLECTION (IN)	STRESS RANGE (KSI)	HORIZONTAL SHEAR (KSI)
EXT		.000	.00000	.000	.000
1	6.000				
INT		.000	.00000	.000	.000
EXT		1.936	.00070	2.608	1.123
2	6.000				
INT		.345	.00043	.486	1.123
EXT		7.038	.00113	4.217	4.084
3	6.000				
INT		1.255	.00069	.786	4.084
EXT		12.073	.00196	7.303	7.006
4	6.000				
INT		2.153	.00119	1.360	7.006
EXT		17.068	.00280	10.433	9.905
5	6.000				
INT		3.043	.00170	1.944	9.905
EXT		21.620	.00355	13.296	10.459
6	5.000				
INT		3.854	.00217	2.476	10.459
EXT		25.217	.00407	15.551	9.775
7	4.000				
INT		4.487	.00251	2.891	9.775

EXT		26.389	.00423	16.137	10.230
8	4.000				
INT		4.695	.00260	3.000	10.230
EXT		26.574	.00423	16.137	10.302
9	4.000				
INT		4.728	.00260	3.000	10.302
EXT		26.724	.00423	16.137	10.360
10	4.000				
INT		4.755	.00260	3.000	10.360
EXT		26.855	.00423	16.137	10.411
11	4.000				
INT		4.778	.00260	3.000	10.411

TAPERED END INVESTIGATION

GIRDER NO.	U.S. FLANGE		D.S. FLANGE		WEB THICKNESS (IN)
	WIDTH (IN)	THICK (IN)	WIDTH (IN)	THICK (IN)	
1	8.000	.5000	12.000	.5000	.5000
2	8.000	.5000	12.000	.5000	.5000
3	8.000	.5000	12.000	.5000	.5000
4	8.000	.5000	12.000	.5000	.5000
5	8.000	.5000	12.000	.5000	.5000
6	8.000	.5000	12.000	.5000	.6250
7	8.000	.5000	12.000	.5000	.6250
8	8.000	.5000	12.000	.5000	.6250
9	8.000	.5000	12.000	.5000	.6250
10	8.000	.5000	12.000	.5000	.6250
11	8.000	.5000	12.000	.5000	.6250
12	10.000	.5000	10.500	.5000	.6250

LOAD COMBINATION 1

PLATE STRENGTH 36.0 KSI

GIRDER NO.	STRESS AT CRITICAL SECT		STRESS AT 48 inches		STRESS AT END DIAPHRAGM	
	U.S.	D.S.	U.S.	D.S.	U.S.	D.S.
	(KSI)		(KSI)		(KSI)	
1	.00	.00	.00	.00	.00	.00
2	-.34	-.49	-.29	-.42	-.44	-.60
3	-5.13	-7.32	-4.40	-6.36	-6.61	-9.02
4	-11.28	-16.10	-9.67	-13.99	-14.53	-19.84
5	-17.43	-24.89	-14.95	-21.63	-22.46	-30.66
6	-20.09	-30.08	-16.04	-24.22	-22.72	-32.76
7	-21.04	-31.95	-16.01	-24.17	-22.68	-32.69
8	-20.81	-31.59	-15.84	-23.90	-22.43	-32.33
9	-20.90	-31.72	-15.90	-24.00	-22.52	-32.46
10	-20.90	-31.72	-15.90	-24.00	-22.52	-32.46
11	-20.90	-31.72	-15.90	-24.00	-22.52	-32.46
12	-13.13	-34.47	-11.14	-19.75	-15.21	-26.07

LOAD COMBINATION 2

PLATE STRENGTH 36.0 KSI

GIRDER NO.	STRESS AT CRITICAL SECT		STRESS AT 48 inches		STRESS AT END DIAPHRAGM	
	U.S.	D.S.	U.S.	D.S.	U.S.	D.S.
	(KSI)		(KSI)		(KSI)	
1	.00	.00	.00	.00	.00	.00
2	-.65	-.92	-.55	-.80	-.83	-1.14
3	-6.04	-8.63	-5.18	-7.50	-7.79	-10.63
4	-12.19	-17.41	-10.46	-15.13	-15.71	-21.45
5	-18.35	-26.20	-15.73	-22.76	-23.64	-32.27
6	-20.87	-31.26	-16.67	-25.17	-23.61	-34.04
7	-21.72	-32.97	-16.53	-24.95	-23.41	-33.75
8	-21.41	-32.51	-16.29	-24.59	-23.07	-33.27
9	-21.50	-32.64	-16.36	-24.69	-23.17	-33.40
10	-21.50	-32.64	-16.36	-24.69	-23.17	-33.40
11	-21.50	-32.64	-16.36	-24.69	-23.17	-33.40
12	-13.51	-35.47	-11.46	-20.32	-15.65	-26.82

LOAD COMBINATION 4

PLATE STRENGTH 36.0 KSI

GIRDER NO.	STRESS AT CRITICAL SECT		STRESS AT 48 inches		STRESS AT END DIAPHRAGM	
	U.S.	D.S.	U.S.	D.S.	U.S.	D.S.
	(KSI)		(KSI)		(KSI)	
1	-.67	-1.23	-.52	-.73	-.70	-.95
2	-.92	-1.31	-.79	-1.14	-1.18	-1.61
3	-.92	-1.31	-.79	-1.14	-1.18	-1.61
4	-.92	-1.31	-.79	-1.14	-1.18	-1.61
5	-.92	-1.31	-.79	-1.14	-1.18	-1.61
6	-.79	-1.18	-.63	-.95	-.89	-1.29
7	-.68	-1.03	-.52	-.78	-.73	-1.05
8	-.60	-.91	-.46	-.69	-.65	-.94
9	-.60	-.91	-.46	-.69	-.65	-.94
10	-.60	-.91	-.46	-.69	-.65	-.94
11	-.60	-.91	-.46	-.69	-.65	-.94
12	-.38	-.99	-.32	-.57	-.44	-.75

LOAD COMBINATION 5

PLATE STRENGTH 36.0 KSI

GIRDER NO.	STRESS AT CRITICAL SECT		STRESS AT 48 inches		STRESS AT END DIAPHRAGM	
	U.S.	D.S.	U.S.	D.S.	U.S.	D.S.
	(KSI)		(KSI)		(KSI)	
1	.00	.00	.00	.00	.00	.00
2	-.14	-.20	-.12	-.17	-.18	-.25
3	-.42	-.60	-.36	-.52	-.54	-.74
4	-.42	-.60	-.36	-.52	-.54	-.74
5	-.42	-.60	-.36	-.52	-.54	-.74
6	-.36	-.54	-.29	-.44	-.41	-.59
7	-.31	-.47	-.24	-.36	-.34	-.49
8	-.28	-.42	-.21	-.32	-.30	-.43
9	-.28	-.42	-.21	-.32	-.30	-.43
10	-.28	-.42	-.21	-.32	-.30	-.43
11	-.28	-.42	-.21	-.32	-.30	-.43
12	-.17	-.46	-.15	-.26	-.20	-.35

LOAD COMBINATION 6

PLATE STRENGTH 36.0 KSI

GIRDER NO.	STRESS AT CRITICAL SECT		STRESS AT 48 inches		STRESS AT END DIAPHRAGM	
	U.S.	D.S.	U.S.	D.S.	U.S.	D.S.
	(KSI)		(KSI)		(KSI)	
1	.00	.00	.00	.00	.00	.00
2	-.36	-.52	-.31	-.45	-.47	-.64
3	-4.89	-6.98	-4.19	-6.06	-6.30	-8.60
4	-10.41	-14.86	-8.93	-12.92	-13.41	-18.31
5	-15.86	-22.65	-13.60	-19.68	-20.44	-27.91
6	-18.14	-27.16	-14.49	-21.87	-20.52	-29.58
7	-18.91	-28.71	-14.39	-21.72	-20.38	-29.38
8	-18.75	-28.46	-14.27	-21.53	-20.20	-29.13
9	-18.99	-28.83	-14.45	-21.82	-20.47	-29.51
10	-19.11	-29.01	-14.54	-21.95	-20.59	-29.69
11	-19.21	-29.16	-14.62	-22.06	-20.70	-29.85
12	-12.12	-31.82	-10.28	-18.24	-14.04	-24.07

 DIAGONAL INVESTIGATION

HORIZONTAL DISTANCE
FROM QUOIN CONTACT (IN)
QUOIN SIDE MITER SIDE

HORIZONTAL SET 1 77.50 501.50

VERTICAL DISTANCE
FROM GIRDER WEB (IN)

GIRDER AT TOP	GIRDER AT BOTTOM	DISTANCE FROM TOP GIRDER	DISTANCE FROM BOTTOM GIRDER	
				GIRDER AT TOP
VERTICAL SET 1	1	12	36.75	36.75

DISTANCE FROM D.S.
SIDE OF SKIN PLATE (IN)

POSITIVE DIAGONAL 58.375
NEGATIVE DIAGONAL 57.375

LOAD CASE 4 DESIGN STRENGTH 48.6 KSI

GATE DIAGONAL PARAMETERS

EM 1110-2-2703

LINE NO.	ITEM	POS DIAGONAL	NEG DIAGONAL
1	R	.0799	-.0849
2	Q	.17E+10	.15E+10
3	D MINIMUM	5.99	-6.99
4	D-DELTA	15.18	-14.29
5	D MAXIMUM	8.18	-8.30
6	D SELECTED	7.85	-7.00
7	QD	.14E+11	-.11E+11

DIAGONAL STRESSES

8	GATE STATIONARY	25.12	23.82
9	GATE OPENING	5.96	44.18
10	GATE CLOSING	47.52	.03
11	DIAGONAL AREAS	12.00	10.00

LOAD CASE 5 DESIGN STRENGTH 48.6 KSI

GATE DIAGONAL PARAMETERS

EM 1110-2-2703

LINE NO.	ITEM	POS DIAGONAL	NEG DIAGONAL
1	R	.0567	-.0592
2	Q	.27E+10	.26E+10
3	D MINIMUM	9.20	-9.83
4	D-DELTA	21.39	-20.50
5	D MAXIMUM	11.56	-11.30
6	D SELECTED	10.55	-9.84
7	QD	.28E+11	-.25E+11

DIAGONAL STRESSES

8	GATE STATIONARY	23.97	23.33
9	GATE OPENING	3.07	45.13
10	GATE CLOSING	46.30	.02
11	DIAGONAL AREAS	26.00	24.00

GATE PROPERTIES

GATE WT. (STEEL ONLY) 222.426 K

CENTER OF GRAV. (FROM W.L.) 23.372 IN

----- END OF INVESTIGATION MODULE -----

**WATERWAYS EXPERIMENT STATION REPORTS
PUBLISHED UNDER THE COMPUTER-AIDED
STRUCTURAL ENGINEERING (CASE) PROJECT**

	Title	Date
Technical Report K-78-1	List of Computer Programs for Computer-Aided Structural Engineering	Feb 1978
Instruction Report O-79-2	User's Guide:Computer Program with Interactive Graphics for Analysis of Plane Frame Structures (CFRAME)	Mar 1979
Technical Report K-80-1	Survey of Bridge-Oriented Design Software	Jan 1980
Technical Report K-80-2	Evaluation of Computer Programs for the Design/Analysis of Highway and Railway Bridges	Jan 1980
Instruction Report K-80-1	User's Guide:Computer Program for Design/Review of Curvilinear Conduits/Culverts (CURCON)	Feb 1980
Instruction Report K-80-3	A Three-Dimensional Finite Element Data Edit Program	Mar 1980
Instruction Report K-80-4	A Three-Dimensional Stability Analysis/Design Program (3DSAD) Report 1:General Geometry Module Report 3:General Analysis Module (CGAM) Report 4:Special-Purpose Modules for Dams (CDAMS)	Jun 1980 Jun 1982 Aug 1983
Instruction Report K-80-6	Basic User's Guide:Computer Program for Design and Analysis of Inverted-T Retaining Walls and Floodwalls (TWDA)	Dec 1980
Instruction Report K-80-7	User's Reference Manual:Computer Program for Design and Analysis of Inverted-T Retaining Walls and Floodwalls (TWDA)	Dec 1980
Technical Report K-80-4	Documentation of Finite Element Analyses Report 1:Longview Outlet Works Conduit Report 2:Anchored Wall Monolith, Bay Springs Lock	Dec 1980 Dec 1980
Technical Report K-80-5	Basic Pile Group Behavior	Dec 1980
Instruction Report K-81-2	User's Guide:Computer Program for Design and Analysis of Sheet Pile Walls by Classical Methods (CSHTWAL) Report 1:Computational Processes Report 2:Interactive Graphics Options	Feb 1981 Mar 1981
Instruction Report K-81-3	Validation Report:Computer Program for Design and Analysis of Inverted-T Retaining Walls and Floodwalls (TWDA)	Feb 1981
Instruction Report K-81-4	User's Guide:Computer Program for Design and Analysis of Cast-in-Place Tunnel Linings (NEWTUN)	Mar 1981
Instruction Report K-81-6	User's Guide:Computer Program for Optimum Nonlinear Dynamic Design of Reinforced Concrete Slabs Under Blast Loading (CBARCS)	Mar 1981
Instruction Report K-81-7	User's Guide:Computer Program for Design or Investigation of Orthogonal Culverts (CORTCUL)	Mar 1981
Instruction Report K-81-9	User's Guide:Computer Program for Three-Dimensional Analysis of Building Systems (CTABS80)	Aug 1981
Technical Report K-81-2	Theoretical Basis for CTABS80:A Computer Program for Three-Dimensional Analysis of Building Systems	Sep 1981
Instruction Report K-82-6	User's Guide:Computer Program for Analysis of Beam-Column Structures with Nonlinear Supports (CBEAMC)	Jun 1982

(Continued)

**WATERWAYS EXPERIMENT STATION REPORTS
PUBLISHED UNDER THE COMPUTER-AIDED
STRUCTURAL ENGINEERING (CASE) PROJECT**

(Continued)

	Title	Date
Instruction Report K-82-7	User's Guide:Computer Program for Bearing Capacity Analysis of Shallow Foundations (CBEAR)	Jun 1982
Instruction Report K-83-1	User's Guide:Computer Program with Interactive Graphics for Analysis of Plane Frame Structures (CFRAME)	Jan 1983
Instruction Report K-83-2	User's Guide:Computer Program for Generation of Engineering Geometry (SKETCH)	Jun 1983
Instruction Report K-83-5	User's Guide:Computer Program to Calculate Shear, Moment, and Thrust (CSMT) from Stress Results of a Two-Dimensional Finite Element Analysis	Jul 1983
Technical Report K-83-1	Basic Pile Group Behavior	Sep 1983
Technical Report K-83-3	Reference Manual:Computer Graphics Program for Generation of Engineering Geometry (SKETCH)	Sep 1983
Technical Report K-83-4	Case Study of Six Major General-Purpose Finite Element Programs	Oct 1983
Instruction Report K-84-2	User's Guide:Computer Program for Optimum Dynamic Design of Nonlinear Metal Plates Under Blast Loading (CSDOOR)	Jan 1984
Instruction Report K-84-7	User's Guide:Computer Program for Determining Induced Stresses and Consolidation Settlements (CSETT)	Aug 1984
Instruction Report K-84-8	Seepage Analysis of Confined Flow Problems by the Method of Fragments (CFRAG)	Sep 1984
Instruction Report K-84-11	User's Guide for Computer Program CGFAG, Concrete General Flexure Analysis with Graphics	Sep 1984
Technical Report K-84-3	Computer-Aided Drafting and Design for Corps Structural Engineers	Oct 1984
Technical Report ATC-86-5	Decision Logic Table Formulation of ACI 318-77, Building Code Requirements for Reinforced Concrete for Automated Constraint Processing, Volumes I and II	Jun 1986
Technical Report ITL-87-2	A Case Committee Study of Finite Element Analysis of Concrete Flat Slabs	Jan 1987
Instruction Report ITL-87-1	User's Guide:Computer Program for Two-Dimensional Analysis of U-Frame Structures (CUFRAM)	Apr 1987
Instruction Report ITL-87-2	User's Guide:For Concrete Strength Investigation and Design (CASTR) in Accordance with ACI 318-83	May 1987
Technical Report ITL-87-6	Finite-Element Method Package for Solving Steady-State Seepage Problems	May 1987
Instruction Report ITL-87-3	User's Guide:A Three Dimensional Stability Analysis/Design Program (3DSAD) Module	Jun 1987
	Report 1:Revision 1:General Geometry	Jun 1987
	Report 2:General Loads Module	Sep 1989
	Report 6:Free-Body Module	Sep 1989

(Continued)

**WATERWAYS EXPERIMENT STATION REPORTS
PUBLISHED UNDER THE COMPUTER-AIDED
STRUCTURAL ENGINEERING (CASE) PROJECT**

(Continued)

	Title	Date
Instruction Report ITL-87-4	User's Guide:2-D Frame Analysis Link Program (LINK2D)	Jun 1987
Technical Report ITL-87-4	Finite Element Studies of a Horizontally Framed Miter Gate Report 1:Initial and Refined Finite Element Models (Phases A, B, and C), Volumes I and II Report 2:Simplified Frame Model (Phase D) Report 3:Alternate Configuration Miter Gate Finite Element Studies--Open Section Report 4:Alternate Configuration Miter Gate Finite Element Studies--Closed Sections Report 5:Alternate Configuration Miter Gate Finite Element Studies--Additional Closed Sections Report 6:Elastic Buckling of Girders in Horizontally Framed Miter Gates Report 7:Application and Summary	Aug 1987
Instruction Report GL-87-1	User's Guide:UTEXAS2 Slope-Stability Package; Volume I, User's Manual	Aug 1987
Instruction Report ITL-87-5	Sliding Stability of Concrete Structures (CSLIDE)	Oct 1987
Instruction Report ITL-87-6	Criteria Specifications for and Validation of a Computer Program for the Design or Investigation of Horizontally Framed Miter Gates (CMITER)	Dec 1987
Technical Report ITL-87-8	Procedure for Static Analysis of Gravity Dams Using the Finite Element Method - Phase 1a	Jan 1988
Instruction Report ITL-88-1	User's Guide:Computer Program for Analysis of Planar Grid Structures (CGRID)	Feb 1988
Technical Report ITL-88-1	Development of Design Formulas for Ribbed Mat Foundations on Expansive Soils	Apr 1988
Technical Report ITL-88-2	User's Guide:Pile Group Graphics Display (CPGG) Post-processor to CPGA Program	Apr 1988
Instruction Report ITL-88-2	User's Guide for Design and Investigation of Horizontally Framed Miter Gates (CMITER)	Jun 1988
Instruction Report ITL-88-4	User's Guide for Revised Computer Program to Calculate Shear, Moment, and Thrust (CSMT)	Sep 1988
Instruction Report GL-87-1	User's Guide:UTEXAS2 Slope-Stability Package; Volume II, Theory	Feb 1989
Technical Report ITL-89-3	User's Guide:Pile Group Analysis (CPGA) Computer Group	Jul 1989
Technical Report ITL-89-4	CBASIN--Structural Design of Saint Anthony Falls Stilling Basins According to Corps of Engineers Criteria for Hydraulic Structures; Computer Program X0098	Aug 1989

(Continued)

**WATERWAYS EXPERIMENT STATION REPORTS
PUBLISHED UNDER THE COMPUTER-AIDED
STRUCTURAL ENGINEERING (CASE) PROJECT**

(Continued)

	Title	Date
Technical Report ITL-89-5	CCHAN—Structural Design of Rectangular Channels According to Corps of Engineers Criteria for Hydraulic Structures; Computer Program X0097	Aug 1989
Technical Report ITL-89-6	The Response-Spectrum Dynamic Analysis of Gravity Dams Using the Finite Element Method; Phase II	Aug 1989
Contract Report ITL-89-1	State of the Art on Expert Systems Applications in Design, Construction, and Maintenance of Structures	Sep 1989
Instruction Report ITL-90-1	User's Guide:Computer Program for Design and Analysis of Sheet Pile Walls by Classical Methods (CWALSHT)	Feb 1990
Technical Report ITL-90-3	Investigation and Design of U-Frame Structures Using Program CUFRBC Volume A:Program Criteria and Documentation Volume B:User's Guide for Basins Volume C:User's Guide for Channels	May 1990
Instruction Report ITL-90-6	User's Guide:Computer Program for Two-Dimensional Analysis of U-Frame or W-Frame Structures (CWFRAM)	Sep 1990
Instruction Report ITL-90-2	User's Guide: Pile Group—Concrete Pile Analysis Program (CPGC) Preprocessor to CPGA Program	Jun 1990
Technical Report ITL-91-3	Application of Finite Element, Grid Generation, and Scientific Visualization Techniques to 2-D and 3-D Seepage and Groundwater Modeling	Sep 1990
Instruction Report ITL-91-1	User's Guide:Computer Program for Design and Analysis of Sheet-Pile Walls by Classical Methods (CWALSHT) Including Rowe's Moment Reduction	Oct 1991
Instruction Report ITL-87-2 (Revised)	User's Guide for Concrete Strength Investigation and Design (CASTR) in Accordance with ACI 318-89	Mar 1992
Technical Report ITL-92-2	Finite Element Modeling of Welded Thick Plates for Bonneville Navigation Lock	May 1992
Technical Report ITL-92-4	Introduction to the Computation of Response Spectrum for Earthquake Loading	Jun 1992
Instruction Report ITL-92-3	Concept Design Example, Computer Aided Structural Modeling (CASM) Report 1:Scheme A Report 2:Scheme B Report 3:Scheme C	Jun 1992 Jun 1992 Jun 1992
Instruction Report ITL-92-4	User's Guide: Computer-Aided Structural Modeling (CASM) - Version 3.00	Apr 1992
Instruction Report ITL-92-5	Tutorial Guide: Computer-Aided Structural Modeling (CASM) - Version 3.00	Apr 1992

(Continued)

**WATERWAYS EXPERIMENT STATION REPORTS
PUBLISHED UNDER THE COMPUTER-AIDED
STRUCTURAL ENGINEERING (CASE) PROJECT**

(Continued)

	Title	Date
Contract Report ITL-92-1	Optimization of Steel Pile Foundations Using Optimality Criteria	Jun 1992
Technical Report ITL-92-7	Refined Stress Analysis of Melvin Price Locks and Dam	Sep 1992
Contract Report ITL-92-2	Knowledge-Based Expert System for Selection and Design of Retaining Structures	Sep 1992
Contract Report ITL-92-3	Evaluation of Thermal and Incremental Construction Effects for Monoliths AL-3 and AL-5 of the Melvin Price Locks and Dam	Sep 1992
Instruction Report GL-87-1	User's Guide:UTEXAS3 Slope-Stability Package; Volume IV, User's Manual	Nov 1992
Technical Report ITL-92-11	The Seismic Design of Waterfront Retaining Structures	Nov 1992
Technical Report ITL-92-12	Computer-Aided, Field-Verified Structural Evaluation Report 1:Development of Computer Modeling Techniques for Miter Lock Gates	Nov 1992
	Report 2:Field Test and Analysis Correlation at John Hollis Bankhead Lock and Dam	Dec 1992
	Report 3:Field Test and Analysis Correlation of a Vertically Framed Miter Gate at Emsworth Lock and Dam	Dec 1993
Instruction Report GL-87-1	User's Guide:UTEXAS3 Slope-Stability Package; Volume III, Example Problems	Dec 1992
Technical Report ITL-93-1	Theoretical Manual for Analysis of Arch Dams	Jul 1993
Technical Report ITL-93-2	Steel Structures for Civil Works, General Considerations for Design and Rehabilitation	Aug 1993
Technical Report ITL-93-3	Soil-Structure Interaction Study of Red River Lock and Dam No. 1 Subjected to Sediment Loading	Sep 1993
Instruction Report ITL-93-3	User's Manual—ADAP, Graphics-Based Dam Analysis Program	Aug 1993
Instruction Report ITL-93-4	Load and Resistance Factor Design for Steel Miter Gates	Oct 1993
Technical Report ITL-94-2	User's Guide for the Incremental Construction, Soil-Structure Interaction Program SOILSTRUCT with Far-Field Boundary Elements	Mar 1994
Instruction Report ITL-94-1	Tutorial Guide: Computer-Aided Structural Modeling (CASM); Version 5.00	Apr 1994
Instruction Report ITL-94-2	User's Guide: Computer-Aided Structural Modeling (CASM); Version 5.00	Apr 1994
Technical Report ITL-94-4	Dynamics of Intake Towers and Other MDOF Structures Under Earthquake Loads: A Computer-Aided Approach	Jul 1994
Technical Report ITL-94-5	Procedure for Static Analysis of Gravity Dams Including Foundation Effects Using the Finite Element Method – Phase 1B	Jul 1994

(Continued)

**WATERWAYS EXPERIMENT STATION REPORTS
PUBLISHED UNDER THE COMPUTER-AIDED
STRUCTURAL ENGINEERING (CASE) PROJECT**

(Concluded)

	Title	Date
Instruction Report ITL-94-5	User's Guide: Computer Program for Winkler Soil-Structure Interaction Analysis of Sheet-Pile Walls (CWALSSI)	Nov 1994
Instruction Report ITL-94-6	User's Guide: Computer Program for Analysis of Beam-Column Structures with Nonlinear Supports (CBEAMC)	Nov 1994
Instruction Report ITL-94-7	User's Guide to CTWALL – A Microcomputer Program for the Analysis of Retaining and Flood Walls	Dec 1994
Contract Report ITL-95-1	Comparison of Barge Impact Experimental and Finite Element Results for the Lower Miter Gate of Lock and Dam 26	Jun 1995
Technical Report ITL-95-5	Soil-Structure Interaction Parameters for Structured/Cemented Silts	Aug 1995
Instruction Report ITL-95-1	User's Guide: Computer Program for the Design and Investigation of Horizontally Framed Miter Gates Using the Load and Resistance Factor Criteria (CMITER-LRFD)	Aug 1995

Destroy this report when no longer needed. Do not return it to the originator.