

# **THOR'S HAMMER: An Aviation Strike Force In Deep Operational Maneuver**

A Monograph  
By  
Major Rick Stockhausen  
Aviation



School of Advanced Military Studies  
United States Army Command and General Staff College  
Fort Leavenworth, Kansas

Second Term AY 94-95

Approved for Public Release; Distribution is Unlimited

# REPORT DOCUMENTATION PAGE

Form Approved  
OMB No. 0704-0188

Public reporting burden for this collection of information is estimated to average 1 hour per response, including the time for reviewing instructions, searching existing data sources, gathering and maintaining the data needed, and completing and reviewing the collection of information. Send comments regarding this burden estimate or any other aspect of this collection of information, including suggestions for reducing this burden, to Washington Headquarters Services, Directorate for Information Operations and Reports, 1215 Jefferson Davis Highway, Suite 1204, Arlington, VA 22202-4302, and to the Office of Management and Budget, Paperwork Reduction Project (0704-0188), Washington, DC 20503.

1. AGENCY USE ONLY (Leave blank)	2. REPORT DATE	3. REPORT TYPE AND DATES COVERED <b>MONOGRAPH</b>
----------------------------------	----------------	--

4. TITLE AND SUBTITLE <b>Thor's Hammer: AN AVIATION STRIKE FORCE IN DEEP OPERATIONAL MANEUVER</b>	5. FUNDING NUMBERS
--	--------------------

6. AUTHOR(S) <b>RICHARD C. STOCKHAYSON</b>	
---	--

7. PERFORMING ORGANIZATION NAME(S) AND ADDRESS(ES) <b>School of Advanced Military Studies Command and General Staff College Fort Leavenworth, KS 66027</b>	8. PERFORMING ORGANIZATION REPORT NUMBER
---	--

9. SPONSORING/MONITORING AGENCY NAME(S) AND ADDRESS(ES) <b>Command and General Staff College Fort Leavenworth, KS 66027</b>	10. SPONSORING/MONITORING AGENCY REPORT NUMBER
--	--

11. SUPPLEMENTARY NOTES

12a. DISTRIBUTION/AVAILABILITY STATEMENT  <b>APPROVED FOR PUBLIC RELEASE DISTRIBUTION UNLIMITED.</b>	12b. DISTRIBUTION CODE
--	------------------------

13. ABSTRACT (Maximum 200 words)

SEE ATTACHMENT

19951107 092

DTIC QUALITY INSPECTED 5

14. SUBJECT TERMS <b>DEEP OPERATIONAL MANEUVER - AVIATION STRIKE FORCE - DEEP OPERATIONS - AIRMECHANIZATION - AIR MECHANIZED UNITS</b>	15. NUMBER OF PAGES <b>59</b>
16. PRICE CODE	

17. SECURITY CLASSIFICATION OF REPORT <b>UNCLAS</b>	18. SECURITY CLASSIFICATION OF THIS PAGE <b>UNCLAS</b>	19. SECURITY CLASSIFICATION OF ABSTRACT <b>UNCLAS</b>	20. LIMITATION OF ABSTRACT <b>UNLIMITED</b>
--	---	--	--

## GENERAL INSTRUCTIONS FOR COMPLETING SF 298

The Report Documentation Page (RDP) is used in announcing and cataloging reports. It is important that this information be consistent with the rest of the report, particularly the cover and title page. Instructions for filling in each block of the form follow. It is important to *stay within the lines* to meet optical scanning requirements.

**Block 1. Agency Use Only (Leave blank).**

**Block 2. Report Date.** Full publication date including day, month, and year, if available (e.g. 1 Jan 88). Must cite at least the year.

**Block 3. Type of Report and Dates Covered.** State whether report is interim, final, etc. If applicable, enter inclusive report dates (e.g. 10 Jun 87 - 30 Jun 88).

**Block 4. Title and Subtitle.** A title is taken from the part of the report that provides the most meaningful and complete information. When a report is prepared in more than one volume, repeat the primary title, add volume number, and include subtitle for the specific volume. On classified documents enter the title classification in parentheses.

**Block 5. Funding Numbers.** To include contract and grant numbers; may include program element number(s), project number(s), task number(s), and work unit number(s). Use the following labels:

<b>C</b> - Contract	<b>PR</b> - Project
<b>G</b> - Grant	<b>TA</b> - Task
<b>PE</b> - Program Element	<b>WU</b> - Work Unit Accession No.

**Block 6. Author(s).** Name(s) of person(s) responsible for writing the report, performing the research, or credited with the content of the report. If editor or compiler, this should follow the name(s).

**Block 7. Performing Organization Name(s) and Address(es).** Self-explanatory.

**Block 8. Performing Organization Report Number.** Enter the unique alphanumeric report number(s) assigned by the organization performing the report.

**Block 9. Sponsoring/Monitoring Agency Name(s) and Address(es).** Self-explanatory.

**Block 10. Sponsoring/Monitoring Agency Report Number.** (If known)

**Block 11. Supplementary Notes.** Enter information not included elsewhere such as: Prepared in cooperation with...; Trans. of...; To be published in... When a report is revised, include a statement whether the new report supersedes or supplements the older report.

**Block 12a. Distribution/Availability Statement.** Denotes public availability or limitations. Cite any availability to the public. Enter additional limitations or special markings in all capitals (e.g. NOFORN, REL, ITAR).

**DOD** - See DoDD 5230.24, "Distribution Statements on Technical Documents."

**DOE** - See authorities.

**NASA** - See Handbook NHB 2200.2.

**NTIS** - Leave blank.

**Block 12b. Distribution Code.**

**DOD** - Leave blank.

**DOE** - Enter DOE distribution categories from the Standard Distribution for Unclassified Scientific and Technical Reports.

**NASA** - Leave blank.

**NTIS** - Leave blank.

**Block 13. Abstract.** Include a brief (*Maximum 200 words*) factual summary of the most significant information contained in the report.

**Block 14. Subject Terms.** Keywords or phrases identifying major subjects in the report.

**Block 15. Number of Pages.** Enter the total number of pages.

**Block 16. Price Code.** Enter appropriate price code (*NTIS only*).

**Blocks 17. - 19. Security Classifications.** Self-explanatory. Enter U.S. Security Classification in accordance with U.S. Security Regulations (i.e., UNCLASSIFIED). If form contains classified information, stamp classification on the top and bottom of the page.

**Block 20. Limitation of Abstract.** This block must be completed to assign a limitation to the abstract. Enter either UL (unlimited) or SAR (same as report). An entry in this block is necessary if the abstract is to be limited. If blank, the abstract is assumed to be unlimited.

SCHOOL OF ADVANCED MILITARY STUDIES

MONOGRAPH APPROVAL

Major Richard C. Stockhausen

Title of Monograph: Thor's Hammer: An Aviation Strike Force  
in Deep Operational Maneuver

---

Approved by:

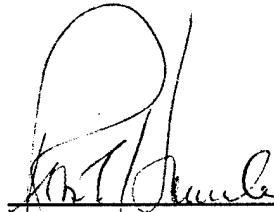

Colonel Robert A. Hammerle, MA

Monograph Director



COL Gregory Fontenot, MA, MMAS

Director, School of  
Advanced Military  
Studies



Philip J. Brookes, Ph.D.

Director, Graduate  
Degree Program

Accepted this 19th Day of May 1995

**ABSTRACT**

**THOR'S HAMMER: AN AVIATION STRIKE FORCE IN DEEP OPERATIONAL MANEUVER**  
by Major Richard C. Stockhausen, USA, 54 pages.

The United States Army's vision of the conventional battlefield of the early 21st century is one characterized by increased lethality, greatly expanded dimensions, and significantly increased dispersion of units. It puts a premium on forces being able to attack simultaneously throughout the depth of this new battlespace. Forces must also be able to dominate the tempo of the battle, delivering lethal pulses of combat power that keep the enemy off balance and destroy the cohesion of his operations. Information technology promises to greatly enhance forces' potential tempo of operations by improving the speed, accuracy, and reliability of battle command systems. Maneuver on the future battlefield, especially operational maneuver, will present new challenges. Maneuver forces as currently structured may not be capable of meeting the requirements of simultaneity and depth of action in the 21st century.

This monograph explores one path to structuring units for effective maneuver on the future battlefield. Specifically, it examines the viability of an aviation strike force (ASF) in deep operational maneuver. The ASF is an air- and ground-based combined arms formation of roughly division size. To assess the potential of such a formation on the future battlefield, the monograph first explores the theoretical foundations of modern deep operational maneuver developed by Tukhachevskiy, Triandafilov, J.F.C. Fuller, and Guderian. It then examines the concepts developed by Simpkin and Von Senger und Etterlin for employing rotary-wing aircraft in operational maneuver. Based on these theoretical reviews, an ASF structure is proposed, based on units and equipment likely to be available in the early 21st century. The analysis of this organization reveals that it has immense potential for deep operational maneuver on an extended, dispersed battlefield.

This monograph concludes that an ASF has the potential to be a highly effective deep maneuver force, enjoying a mobility differential such as that enjoyed by the tank during World War II. This potential warrants a more in-depth study of the ASF concept, its likely strengths, and its limitations.

Accession For	
NTIS CRA&I	<input checked="" type="checkbox"/>
DTIC TAB	<input type="checkbox"/>
Unannounced	<input type="checkbox"/>
Justification _____	
By _____	
Distribution /	
Availability Codes	
Dist	Avail and/or Special
A-1	

## TABLE OF CONTENTS

Title Page .....	i
Approval Sheet .....	ii
Abstract .....	iii
Table of Contents .....	iv
I. Introduction .....	1
II. Deep Operational Maneuver: Theory and Doctrine .....	4
A. Doctrine .....	4
B. Genesis of Modern Deep Operational Maneuver Theory .....	4
C. Imperatives of the 'Deep Operation' .....	9
D. Roles of the Deep Operational Maneuver Forces .....	10
E. Characteristics of a Deep Operational Maneuver Force .....	11
III. Aviation in Deep Operational Maneuver .....	13
A. Early Thoughts .....	13
B. Rotary-Wing Developments .....	14
C. Visions of Airmechanization .....	16
D. Relooking Airmechanization .....	19
IV. Modern Airmechanization: The Aviation Strike Force .....	22
A. General .....	22
B. Designing the ASF .....	22
C. Organizational Structure .....	23
V. The Aviation Strike Force in Deep Operational Maneuver--A Critical Analysis ....	27
A. General .....	27
B. Characteristics and Capabilities .....	27
C. Employment of the Aviation Strike Force .....	32
D. Supporting the Aviation Strike Force .....	35
E. Sustaining the Aviation Strike Force .....	37
VI. Conclusions .....	39
A. Thor's Hammer .....	39
B. Constituting an Aviation Strike Force .....	40
C. Materiel Development .....	41
D. Further Study .....	42

**Figures:**

**Figure 1: Tukhachevskiy's Deep Operation Concept** ..... follows page 6  
**Figure 2: Triandafilov's Deep Operation Concept** ..... follows page 6  
**Figure 3: Simpkin's Airmechanized Division** ..... follows page 17  
**Figure 4: Von Senger und Etterlin's Airmechanized Division** ..... follows page 18  
**Figure 5: The Air Attack Division** ..... follows page 18  
**Figure 6: The Aviation Strike Force** ..... follows page 23

**Endnotes** ..... 43

**Bibliography** ..... 52

## I. Introduction

The United States Army is currently caught up in a maelstrom of change. The geo-strategic environment is reshaping itself in the aftermath of the Cold War. The United States' national security focus is shifting, placing new demands and limitations on its armed forces. Technological development is accelerating, causing some to forecast a military technical revolution in warfare in the early 21st century.<sup>1</sup> In conjunction, existing military technology is becoming more accessible and affordable for a growing number of lesser developed countries. The predicted result is that "the future Army will be smaller, yet have new, expanded, and diverse missions in an unpredictable, rapidly changing world environment."<sup>2</sup> To meet the challenges of its new environment, the future Army will have to be more lethal, flexible, and versatile.<sup>3</sup> To do this, the U.S. Army will have to develop improved warfighting concepts and organizations to exploit them. The helicopter provides one potential basis for developing these concepts and organizations.

The portrait of the future conventional battlefield is one of greatly increased lethality and greatly expanded battlespace.<sup>4</sup> Formations will be increasingly dispersed through the width and depth of the battlefield. They will concentrate only enough to mass combat power at critical times and places then quickly disperse. This battlefield will call for greater depth and simultaneity in operations against enemy forces.<sup>5</sup> The modern helicopter, with its speed, range, and mobility, provides the commander with a tool for meeting these requirements.

The U.S. Army's newest generation of helicopters provides dramatic increases in mobility, lethality, and survivability. Advanced navigation and pilotage, auxiliary fuel systems, and improved performance give these new helicopters unprecedented speed, range, endurance, and adverse weather capabilities. Advanced sensors and designators, precision guided weapons, and improved fire control systems have resulted in a quantum leap in lethality. Improved designs, materials, and countermeasures greatly enhance the battlefield survivability of these new

helicopters over that of the last generation. These new capabilities and the requirements of the projected battlefield call for exploring greater possibilities in employing helicopter formations in the U.S. Army.

Currently, the U.S. Army employs its helicopters in small formations supporting larger ground formations. Each corps and division has an assigned aviation brigade. The size of each aviation brigade varies, but under the Aviation Restructure Initiative (ARI) none will have more than two active duty attack helicopter battalions and three assault helicopter battalions.<sup>6</sup> Like the tank just after World War I, the Army's helicopters are spread throughout the force in 'penny packets.' They have a significant tactical value, but aviation formations lack the robustness to have a significant operational level impact.

In the last decade, several military writers began exploring the operational level possibilities of large aviation formations. They proposed 'airmechanized' divisions, built around and focused on the helicopter. While these formations represent formidable forces at the tactical level, their true value would be at the operational level. Exploiting the mobility of the helicopter, these formations would provide the operational level commander with significantly increased dimensions of depth, tempo, and simultaneity of operations.

The ideas of these writers, however, found little acceptance in the U. S. Army. Its aviation organizations and concepts remain focused on support of ground-based formations at the tactical level. Some believe that the U.S. Army has stagnated in the development of rotary-wing warfighting concepts since its early 'pioneering' in the concepts of 'air mobility' and 'vertical envelopment.' The Chief of Staff of the Army, General Gordon R. Sullivan, recently signaled the potential for this to change. Writing in Military Review, he stated:

"The history of land warfare reflects the manner in which various arms have been integrated into the combat team. Initially, land combat moved from being conducted by unitary armies to being fought by combined arms, ground-based formations. The second step took place when combined arms, ground-based formations became combined arms, ground- and air-based units. Land combat units are currently at this point; however, the

movement is not over. The third step will take place when land combat is waged by formations consisting of *combined arms, air- and ground-based units* [italics added]. This is the direction land combat is now taking."<sup>7</sup>

If General Sullivan is correct, the 'airmechanized' division may become a reality in the 21st century.

This monograph examines the operational potential of a combined arms, air- and ground-based formation organized around the helicopter. Specifically, it analyzes the viability of employing a division-sized, helicopter-based formation as a deep operational maneuver force. The monograph begins with a review of deep operational maneuver theory and doctrine. Existing concepts for employing helicopters in deep operational maneuver are then examined. Based on these reviews, the monograph will propose a potential division-sized 'aviation strike force.' This force will then be analyzed to determine its viability as a deep operational maneuver force. The monograph concludes with an evaluation of the force and recommendations for future study, force structure changes, and material development.

## II. Deep Operational Maneuver: Theory and Doctrine

### A. Doctrine.

Current U.S. Army doctrine refers to maneuver as a 'principle of war,' a 'dynamic of combat power,' and as a 'combat function.' As a principle of war, the object of maneuver is to "place the enemy in a position of disadvantage through the flexible application of combat power."<sup>8</sup> As a dynamic of combat power, it is the ". . . means of positioning forces at decisive points to achieve surprise, psychological shock, physical momentum, massed effects, and moral dominance."<sup>9</sup> As a combat function, "maneuver refers to the employment of forces . . . to achieve relative positional advantage over an enemy force to achieve tactical, operational, or strategic objectives."<sup>10</sup> At the operational level of war, the commander uses maneuver to establish favorable conditions for battle or to exploit tactical actions. Deep operational maneuver refers to the employment of forces beyond the tactical depth of the enemy in order to limit his freedom of action, restrict the tempo of his operations, destroy the coherence of his actions, or to attrit selected parts of his force.<sup>11</sup>

### B. Genesis of Modern Deep Operational Maneuver Theory.

Modern deep operational maneuver theory had its birth in the aftermath of World War I. The price in lives and materiel exacted by the positional warfare 'stalemate' (particularly that of the western front) induced the armies of the major powers to seek ways to return operational maneuver to the battlefield.<sup>12</sup> The search began during the war itself, manifesting itself in new techniques such as the German 'Hutier tactics' and in new technology such as the tank. Nothing proved successful during the war, although some concepts (such as Major General Fuller's Plan 1919) were never truly tested.<sup>13</sup>

- As a result, the 1920s and 30s were a fertile period for thought on restoring operational maneuver to the battlefield. Improving technology, especially developments in tanks and airplanes, gave further impetus to thought on deep maneuver. Tukhachevskiy and Triandafillov in the Soviet Union, J.F.C. Fuller in Great Britain, and Guderian in Germany were some of the leading thinkers on the subject. The general concepts these men developed were amazingly similar, although they varied somewhat in details and emphasis.

### The Soviets

Tukhachevskiy and Triandafillov are referred to by some as the 'father' and 'mother' of the deep operation.<sup>14</sup> They led the intellectual effort that resulted in the development of the Soviet 'deep battle' (glubokiy boy) and 'deep operation' (glubokiy operatsiia) concepts. Of the theorists of deep operational maneuver of the time, they produced what is probably the most in-depth body of thought. Their ideas received official expression in the Soviet Field Service Regulation of 1936 (PU-36).<sup>15</sup> Their concepts continued to serve as a foundation for Soviet doctrine until the demise of the Soviet Union.<sup>16</sup>

The initial focus of Triandafillov's and Tukhachevskiy's thought was at the tactical level. Their 'deep battle' concept was aimed at achieving a breakthrough and exploitation of the enemy's tactical defensive front.<sup>17</sup> During World War I, armies found they could 'break in' to an enemy's defenses, but they would stall before they could break through. The 'deep battle' concept sought to overcome this failure through both simultaneous and successive actions throughout the tactical depth of the enemy's defense.

The 'deep battle' began with a series of actions to contain the enemy's formations. These actions would continue throughout the operation to prevent the enemy from effectively reacting to the breakthrough. Next, attacks were launched at selected points in order to penetrate the defensive lines. Once the enemy's lines had been penetrated, exploiting formations moved through the

breaches and enveloped the enemy's tactical formations. As both Soviet thought and technology matured, the concepts of 'deep battle' were expanded into the 'deep operation.' The focus of the 'deep operation' was to achieve decisive action at the operational level.<sup>18</sup>

The basic form of the 'deep operation' was a classic turning movement at the operational level.<sup>19</sup> To accomplish this, the Soviet's envisioned an all arms operation consisting of two-phases. The first phase focused on the rupture of the enemy's tactical defensive front (a 'deep battle'). The second phase focused on the operational exploitation of the rupture (the actual 'deep operation').

To execute the 'deep operation,' Tukhachevskiy organized his force into two operational echelons. The first echelon consisted of two elements: an infantry-heavy fixing force and a tank-heavy formation acting as a combination of breakthrough force and reserve. The second echelon contained the deep operational maneuver forces. It consisted of highly mobile formations grouped into an exploitation force and independent airborne, aviation, and cavalry formations.

Tukhachevskiy preceded the first phase with an extensive reconnaissance effort to identify weak areas in the enemy defensive front, find critical nodes (command and control facilities, logistics bases, etc.), and locate critical forces (artillery, anti-tank, and reserves). The phase began with an attack along a broad front by the fixing force to contain enemy formations within the tactical defensive front and to suppress enemy fires. The breakthrough force was then committed against a narrow sector of the defensive front, usually at a weak point. Tukhachevskiy stressed the need for achieving surprise at the breakthrough point because it further degraded the enemy's ability to react to the breakthrough attack.<sup>20</sup> As it penetrated, the breakthrough force attempted to totally destroy the defenders in its zone, not just push them back. This was critical for the success of the next phase, providing the operational exploitation force the initial freedom of maneuver it needed. The breakthrough force continued its attack to the tactical depth of the enemy's defense, widening the breach and enveloping and destroying tactical reserves, command and control, and logistics.<sup>21</sup>

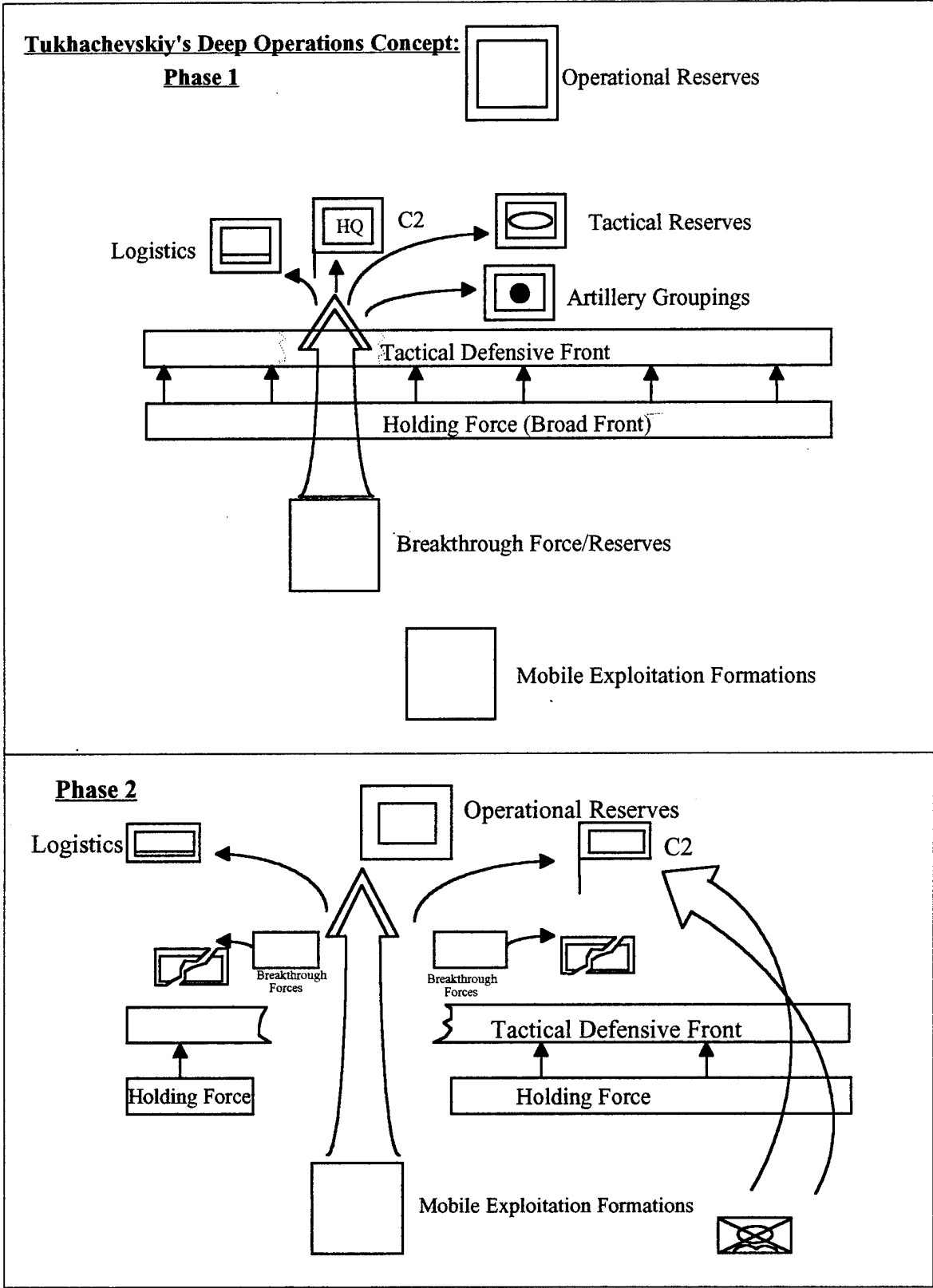
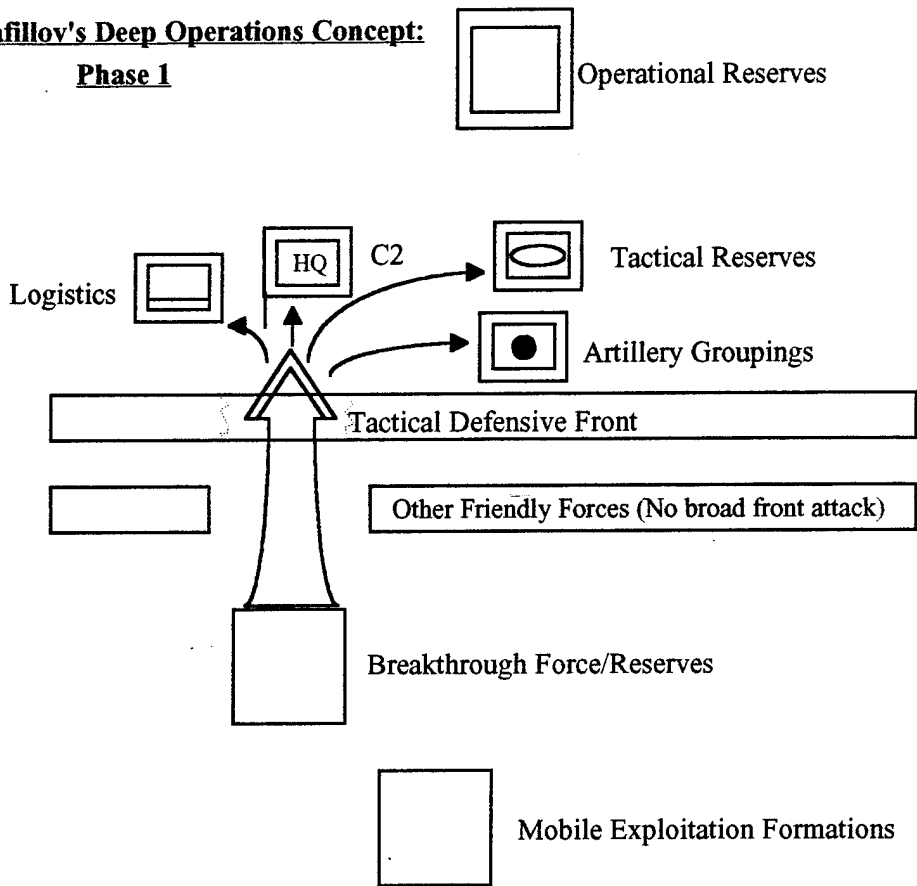

Figure 1.

**Triandafillov's Deep Operations Concept:**

**Phase 1**



**Phase 2**

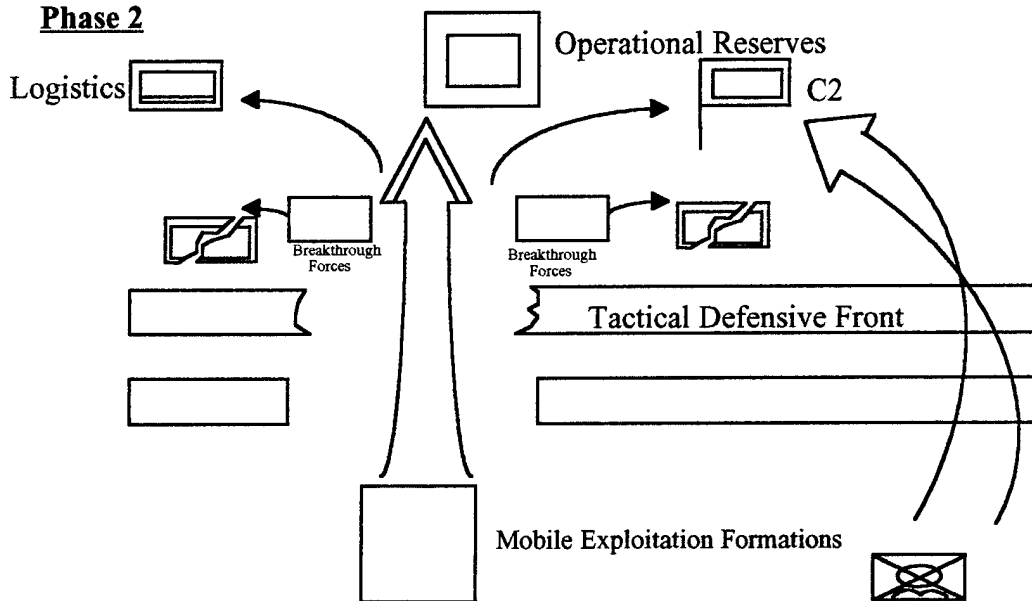

Figure 2.

Phase two began when the enemy's tactical forces were pinned in general and broken through at the selected point. At this juncture, the operational exploitation force was committed through the breach.<sup>22</sup> In conjunction, independent formations of airborne, aviation, and cavalry conducted simultaneous deep engagements to contain the enemy's operational reserves and reinforcements, disrupt his command and control, and deny him critical resources.<sup>23</sup> While these independent formations limited the enemy's freedom of action, the mobile formations of the exploitation force attacked into the enemy's operational depths, turning the defensive line out of its position, destroying operational reserves and command and control facilities, and seizing or destroying communications and logistics (see figure 1.).

Triandafillov differs from Tukhachevskiy in that he does not stress the broad front assault in the first phase. Rather, he focuses the entire operation on a very narrow front, emphasizing depth and high tempo to achieve the rupture, while accepting the higher risk of not tying down the bulk of the enemy's tactical forces.<sup>24</sup> His second phase is very similar to Tukhachevskiy's concept (see figure 2.).

An important concept that Triandafillov introduces is the ". . . *interchangeability* of forces and fire."<sup>25</sup> The thrust of the concept is that the effects of fires could replace the actual presence of troops in certain circumstances. Specifically, fires could be used in lieu of troops to contain enemy formations at both the tactical and operational levels. The concept implies a flexibility of means between maneuver, shock action, and firepower in achieving depth and simultaneity in operations.

#### The British.

In Great Britain, J.F.C. Fuller was one of the foremost advocates of armored warfare, with its inherent possibilities for operational maneuver. In general, Fuller's deep operational maneuver concept looks much like that developed by the Tukhachevskiy and Triandafillov. Like his Soviet counterparts, his ideas involve turning and dislocating the enemy by exploiting open flanks,

interrupted fronts, or penetrations with highly mobile forces.<sup>26</sup> Unlike the Soviets, he developed his concepts for forces of limited size, not massed armies. He advocated an exclusively tank and mechanized force, with its entire structure possessing superior mobility.<sup>27</sup>

Fuller's concept focuses heavily on the psychological impact created by deep maneuver. He stated that ". . . terror and not destruction was the true aim and end of armored warfare . . . to attack the nerves of the army, and through its nerves the will of its commander. . . ."28 In other words, he stressed paralysis of the enemy over destruction. He saw rapid mobility as the key requirement for a small force to accomplish this paralysis.<sup>29</sup>

Fuller also believed that improved, armored cross-country mobility would force existing linear tactics to evolve into nonlinear tactics. Rear areas would become more vulnerable to attacks. The power of surprise would be increased because there were increased options in where and when to attack. An army would no longer be safe anywhere throughout its depth, necessitating all-around protection (and thereby thinning forces at all points).<sup>30</sup> Fuller's concept capitalized on these points.

Like the Soviets, Fuller envisioned a two-phase operation. In the first phase, a medium mechanized force would punch through the enemy lines, attacking up to the enemy artillery line. It would then exploit its penetration at the tactical level by rolling up the enemy's flanks and widening the breach. In the second phase, a light armored, highly mobile force would pass through the breach to destroy enemy command and control centers. Fuller saw the enemy command and control system as the operational center of gravity. He sought to initially 'throw it off balance' by the speed of his operations and then destroy it before it could recover. He believed its destruction by the mobile force would be like a "shot in the brain"<sup>31</sup> to the enemy force.

#### The Germans.

In Germany, Heinz Guderian's ideas bore many similarities to the concepts of Fuller, Tukhachevskiy, and Triandafilov. The operation envisioned by Guderian followed the same

two-phase pattern seen in the Soviet and British concepts. It varied slightly, however, in some of its particulars.

During the first phase, the commander would select a breakthrough point favorable for the employment of the operational exploitation force and launch a concentrated surprise attack against that portion of the enemy line. The assaulting forces would break in fast and deep while aviation and long-range artillery interdicted tactical reserves. Simultaneously, the rest of the enemy's defensive area would be brought under attack to hold forces away from the penetration.<sup>32</sup>

During the second phase, a mobile, combined arms force would be committed through the breach in a tactical exploitation. The force would be roughly grouped into five echelons with five specific missions. The first echelon (the strongest of the five) would seek out and destroy tactical (especially mobile) reserves in their assembly areas, before they could be brought to bear against the spearhead. The second echelon would attack command and control nodes, while the third would destroy artillery groupings. The fourth echelon would destroy mobile anti-tank formations, a task Guderian saw to be as critical as eliminating the reserves. Finally, the fifth echelon would move forward to reduce the infantry battle zone. As the exploitation force unhinged the tactical defense, it would transition to the pursuit and operational exploitation.<sup>33</sup>

### C. Imperatives of the 'Deep Operation.'

The concepts of Tukhachevskiy, Triandafilov, Fuller, and Guderian all stress a common set of 'imperatives' for conducting 'deep operations.' *Coherence of action* of the force, focused on a decision at the operational level, is of paramount importance. *Simultaneity* and *depth* are essential for applying combat power to best effect against the enemy. Dominating the *tempo* of operations is vital for retaining the initiative and achieving operational success.

One premise underlying Tukhachevskiy's development of his 'deep operation' concept was his belief that a prepared, conventional army could not be defeated by a single, decisive blow. Instead, it required a series of blows, properly orchestrated, to achieve a decisive effect.<sup>34</sup> Each of the concepts reviewed above focuses on the orchestration of the actions of the entire force, molding them into a coherent pattern to achieve a decision at the operational level.

The enemy must be struck simultaneously and in depth, as well as sequentially. To Tukhachevskiy, simultaneity and depth were the means to bring the greatest amount of combat power to bear against the enemy.<sup>35</sup> Fuller and Guderian emphasized simultaneity and depth of action to achieve surprise and to 'paralyze' the enemy's ability to react. Triandafilov's concept of interchangeability of forces and fires provides flexibility in the means of achieving simultaneity and depth. In each concept, simultaneity and depth were critical to limiting the enemy's freedom of action.

Dominating the tempo of operations enhances surprise, keeps the enemy off balance, and preserves freedom of action. Each theorist saw this as especially critical for the deep operational maneuver forces. They carefully designed their deep operational maneuver formations to be capable of a much superior tempo of operations than the bulk of forces on the battlefield.

#### D. Roles of the Deep Operational Maneuver Forces.

The deep operational maneuver forces in the concepts reviewed above filled one of two roles. One role was limiting the enemy's operational freedom of action, restricting the tempo of his operations, and disrupting the operational coherence of his actions. This includes actions such as interdicting lines of communication to block the movement of reserves or reinforcements, cut off the flow of supplies, or deny access to key resources. It also includes attacks to disrupt functions such as command and control and logistics. The second role is destroying operationally decisive

formations or functions. These include operational reserves, command and control systems, or logistics systems.

#### E. Characteristics of a Deep Operational Maneuver Force.

In designing their deep operational maneuver forces, Tukhachevskiy, Triandafillov, Fuller, and Guderian stressed mobility over firepower and protection. Their formations possessed a degree of mobility that was considerably higher than that of other formations on the battlefield. These formations combined superior cross-country movement, speed, range, and endurance in order to dominate the tempo of operations while they attained operational depth.

The operational exploitation forces in each concept consisted of mechanized, motorized, tank, and cavalry elements. These were the most mobile formations of the time, and they also possessed a balance of firepower and protection. To ensure the superior mobility of their forces, the Soviets developed specialized moto-mech formations (a combination of motorized and mechanized units) for optimum mobility across a wide spectrum of terrain types.<sup>36</sup> Fuller, who advocated an entirely mechanized army, advocated the use of light tanks for maneuvering to operational depths because of their superior speed and range. Guderian stressed the need for the supporting arms in the mobile formations to match the mobility and tempo of the main battle vehicles.<sup>37</sup> He also emphasized the need to employ these mobile formations in mass, not split among less mobile formations.

Airborne forces presented a challenge as deep operational maneuver forces. They had great mobility while being transported by aircraft, but it dropped to almost nothing once they were inserted. Thereafter, their tempo of operations was severely limited as was their combat worth. Tukhachevskiy and Fuller advocated mechanizing airborne forces, providing them a secondary means of mobility once inserted into the enemy's operational depths. This would enable them to

maintain a high tempo of operations and retain a high combat worth. Today, the BMD-series airborne infantry combat vehicle is a direct result of Tukhachevskiy's proposals.

The design of these deep operational maneuver forces accepted risk in trading some firepower and protection for superior mobility. These theorists believed, however, that an enemy's tactical and operational rear was far less lethal than his defensive front.<sup>38</sup> This allowed trading a measure of firepower and protection while still maintaining superior relative lethality and survivability.

### III. Aviation in Deep Operational Maneuver

#### A. Early Thoughts.

Perhaps the most outstanding proponent of aviation's role in deep operational maneuver was Guilio Douhet. In Command of the Air, he paints a vision of air armadas maneuvering to operational and strategic depths and shattering the enemy. These air forces, he claimed, would make ground forces almost irrelevant, except to 'mop up'.<sup>39</sup> While Tukhachevskiy, Triandafillov, Fuller, and Guderian did not share Douhet's vision, they did recognize that aviation had an integral role to play in their deep operations concepts.

The Soviets recognized very early that aviation would be an important, even decisive, component of modern warfare.<sup>40</sup> Accordingly, they devoted considerable effort to the development of their air arm. Generally, air power was considered an extension of artillery. Its purpose was to deliver "... firepower and destruction beyond the range of artillery pieces."<sup>41</sup> Aviation added new dimensions of depth and simultaneity and Tukhachevskiy and Triandafillov integrated it into their deep operations concepts.

During the breakthrough, aviation had several roles. It would provide close support to the advancing forces, increasing the combat power in the breakthrough sector. It would also isolate the breakthrough sector, interdicting and destroying tactical reserves and other forces reacting to the breakthrough attack.<sup>42</sup> During the operational exploitation, aviation would assist by paralyzing portions of the enemy's operational rear area.<sup>43</sup> Tukhachevskiy stressed the use of *independent* air formations to limit an enemy's operational freedom of action by destroying his vital communications.<sup>44</sup>

In addition to delivering firepower, Tukhachevskiy and Triandafillov recognized that aviation provided a source of operational mobility. They recognized the role it could play in delivering airborne troops to the enemy's operational depths. They also recognized the role aviation played in

enabling a greater simultaneity of operations. It enabled maneuver forces to operate in the enemy's operational depth even before his tactical defenses had been penetrated.

Fuller also saw great possibilities for aviation in deep operations. He seems almost to echo Douhet in his evaluation of its potential:

"[Aviation] added a new dimension to the art of war, so full of possibilities that some think it may eventually grow so powerful as to render armies and navies useless. Even if this should not prove to be the case, it is a certainty that it will greatly modify them."<sup>45</sup>

Fuller tailored the use of aviation in his deep operations concept in keeping with his 'shot in the brain' approach. Aviation served two primary purposes: deep reconnaissance and interdiction of the enemy's command and control apparatus.<sup>46</sup>

Guderian's concept used aviation in reconnaissance, close support, and interdiction roles. Independent aviation formations, he believed, could be used for attacks against a common deep objective, handing it over to the ground forces as they came in range. He also saw these formations providing protection for the panzer formations by interdicting the movement of reserves and destroying artillery, command and control, and anti-tank resources. He even admitted to the possibility of aviation taking the decisive role, with the panzers in support. In Achtung-Panzer!, he states: ". . . it can also work the other way around, with the operations of tank forces supporting the ends of aerial warfare."<sup>47</sup>

#### B. Rotary-Wing Developments.

Although there was military interest in rotary-wing aircraft as early as 1912, it was not until after World War II that serious development of helicopters in battlefield roles began.<sup>48</sup> The United States, with its technological and industrial superiority, took an early lead in developing the helicopter for military service. By the Korean War, military helicopters performed a number of battlefield missions, including medevac, resupply, transportation, aerial observation, and command and control enhancement.<sup>49</sup> In the 1960s, the U.S. Army's Tactical Mobility Requirements Board

(the 'Howze Board'), propelled the helicopter into major battlefield roles. It recommended the adoption of the 'airmobile concept' by the Army. In fact, the Howze Board saw such a transition as inevitable as that from animal mobility to motor.<sup>50</sup>

The creation of the U.S. Army's first air assault division was a direct product of the board's recommendations. With over 400 aircraft, the division had impressive tactical and operational mobility. Its helicopters provided not only mobility, but fire support and reconnaissance, as well.<sup>51</sup> This division, the 1st Cavalry Division (Airmobile), proved to be both an effective tactical and operational level formation in the crucible of the Vietnam War.

Although the United States pioneered the first major employment of helicopters in operational maneuver, further development stagnated in the post-Vietnam era. Only a single airmobile division was retained, while most of Army aviation was grouped into tactical formations and spread throughout the existing force structure. The United States did, however, pioneer another important development in the employment of the helicopter on the battlefield. It began to consider its attack helicopter units as maneuver formations rather than just fire support units. Integrating these formations into the AirLand Battle doctrine of the 1980s led to the development of the 'deep attack.' In the deep attack, attack helicopter battalions would maneuver into the enemy's tactical depth to break up the coherence of his attack and shatter the tempo of his operations. Tukhachevskiy would have recognized the 'deep attack' as a logical component of his 'deep battle.'

While the Americans took the lead in integrating helicopters into the tactical deep battle, the Soviet Union continued the development of the helicopter and airmobile forces for deep operations. They integrated helicopters with airborne units, a logical evolution of Tukhachevskiy's concepts, and formed air assault and airmobile assault units at the army and front levels specifically for conducting deep operational maneuver.<sup>52</sup> According to some experts, the Soviets consider the combat worth of one of their air assault brigades, employed at operational depth, to be equivalent

to that of a tank division.<sup>53</sup> In keeping with Tukhachevskiy's concepts, the Soviets developed mechanized air assault formations using the BMD-series airborne assault vehicle. This provided the air assault unit secondary mobility once it was on the ground at operational depths. To support this, the Soviets developed a series of heavy lift helicopters capable of carrying the vehicles and the necessary logistics to give them endurance in the enemy's operational depth.

### C. Visions of Airmechanization.

In the early 1980s, several military thinkers began advocating a greater role on the battlefield for the helicopter. They saw conditions developing that they believed would bring about a "rotary-wing revolution"<sup>54</sup> on the battlefield. Several trends in modern warfare were combining to reduce the decisiveness of mechanized formations, particularly in deep operational maneuver. Simultaneously, these (and other) trends were setting the conditions that could make the helicopter the centerpiece of maneuver warfare. Like the tank, however, the helicopter would not realize its potential as long as it was piecemealed out in support of established formations. They argued that helicopters must be employed en masse to achieve best effect. Accordingly, they proposed 'airmechanized' divisions to gain the correct balance of combat power. Foremost among these thinkers were Brigadier General Richard Simpkin, a British armor officer, and General Doctor von Senger und Etterlin, then Commander in Chief, Allied Forces Central Europe.

Both men felt that the primary trend affecting the decisiveness of mechanized formations was the proliferation of mechanized forces throughout the world's major armies. With the bulk of these armies generally mechanized, the mobility differential that had made armored forces so decisive in modern maneuver warfare would disappear. Without this mobility differential, there could be no 'mobile force' capable of effectively exploiting to operational depths. With the bulk of all formations equally mobile, the decisive component of deep operational maneuver would be lost.

The answer to restoring the mobility differential required by the 'mobile formations,' they felt, was the helicopter. It could provide a degree of mobility several orders of magnitude higher than any armored fighting vehicle, tracked or wheeled. Simpkin expressed the relationship as "rotor is to track as track is to boot."<sup>55</sup> The helicopter's advantage was not just speed, but its ability to use ground tactically without being tied to it for mobility. These capabilities would provide a helicopter-based force superior range, agility, and tempo in its operations.

Another trend affecting the dominance of mechanized forces in maneuver warfare was the increasing lethality of the modern battlefield. These forces were ". . . slowing down against the mounting power of attrition by modern firepower. . . ." <sup>56</sup> Advanced sensors and precision guided munitions, especially, were negating the mobility and protection of armored vehicles. Simpkin and Von Senger und Etterlin believed that emerging helicopters could restore the power of maneuver.<sup>57</sup> In fact, a very similar concern that the balance between firepower and maneuver had swung too far toward firepower led the U.S. Army to begin exploring the potential of airmobility in the 1960s.<sup>58</sup>

In his book, Antitank, Simpkin proposed what he termed an "airmechanized division."<sup>59</sup> It consisted of an air cavalry brigade, an artillery brigade, and a mechanized brigade formed from composite infantry/armor battalions. In addition, it included other combat support and service support elements.<sup>60</sup> With over 1200 armored fighting vehicles, 470 helicopters, and approximately 22,500 soldiers it represented a considerable amount of combat power rolled into a single division.<sup>61</sup> Although it contained potent ground-based forces, Simpkin intended for the air cavalry brigade to be the primary combat element.<sup>62</sup> With over 300 scout and attack helicopters, this brigade represented an aviation combat force unmatched anywhere in the world (see figure 3.).

Simpkin believed his airmechanized division would be a tactical-operational formation. With its weight of combat power, superior tempo of operations, and expanded battlespace, the division would naturally be the principal combat formation of a corps. It was equally suited, however, for

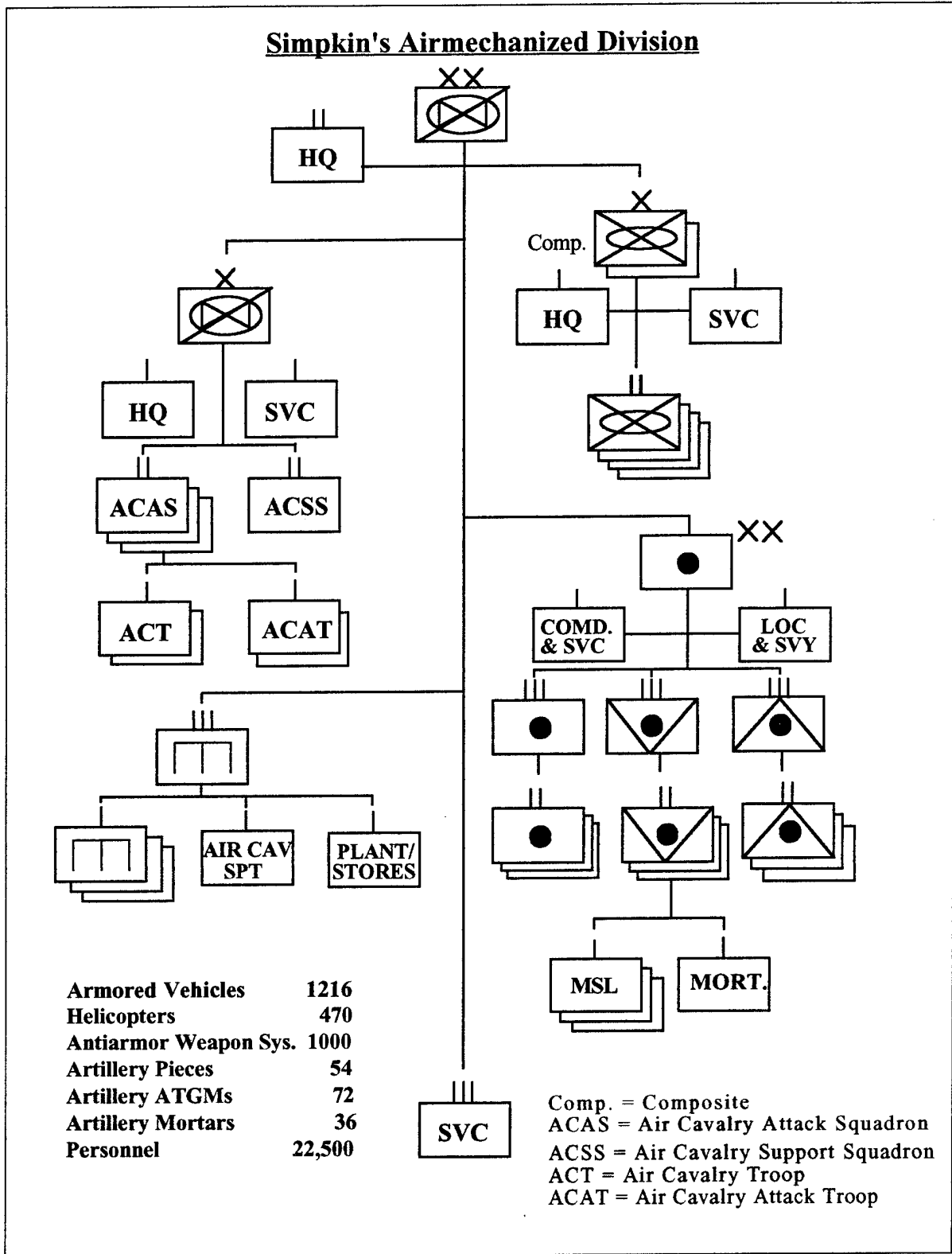

Figure 3.

conducting operational level maneuver, either independently or under the control of a higher formation.<sup>63</sup> Simpkin admitted that such a force would be very expensive, but he believed that its effectiveness would justify the cost.<sup>64</sup>

Although Simpkin's airmechanized division was a balance of ground and aviation units, he predicted the inevitability of independent helicopter formations in the future<sup>65</sup> He believed technology was reaching a point where increases in the cross-country mobility of ground vehicles was providing diminishing returns in terms of cost, fuel consumption, and ergonomics. He stated that mobility increases would be better accomplished ". . . by getting off the ground than by staying on it."<sup>66</sup> Seeking mobility increases by exploiting the third dimension would be easier and more economical as technology progressed. Because of this, it was inevitable that aviation units would become the 'mobile formations' for deep operational maneuver.

General Doctor von Senger und Etterlin also made a proposal for an 'airmechanized division.' He believed that "[t]he first general principle with regard to organization should not be to scatter the new forces [helicopter units] amongst the old but rather to concentrate them in independent large formations"<sup>67</sup> His 'airmechanized division' consisted of an 'airmechanized brigade' of attack helicopters, an airmobile infantry brigade, and an airtransport brigade of lift helicopters.<sup>68</sup> Von Senger und Etterlin's division is much leaner than that of Simpkin, but it is also entirely airmobile where Simpkin's was not. This allows the division to operate fully unfettered by terrain. The 144 scout and attack helicopters of the 'airmechanized brigade' are clearly the main combat power of the division (see figure 4).

When he wrote, von Senger und Etterlin recognized that contemporary helicopters were not quite capable of fulfilling the requirements of his 'airmechanized' concepts. He envisioned a "Main Battle Air Vehicle (MBAV)"<sup>69</sup> to complement his organization. The MBAV was a helicopter-type vehicle equipped with flexible armament systems, suitable for ". . . area saturation or for precision

## Von Senger und Etterlin's Airmechanized Division

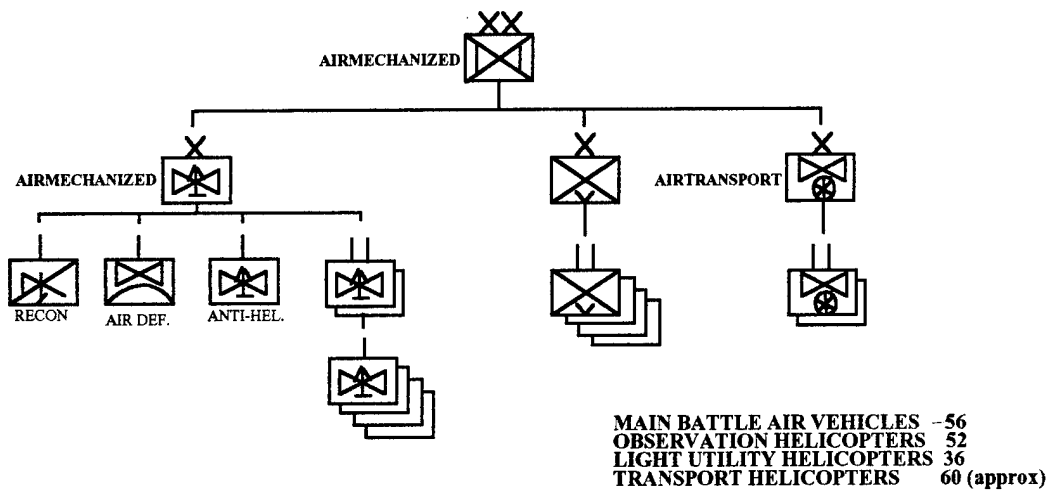

Figure 4.

## Air Attack Division

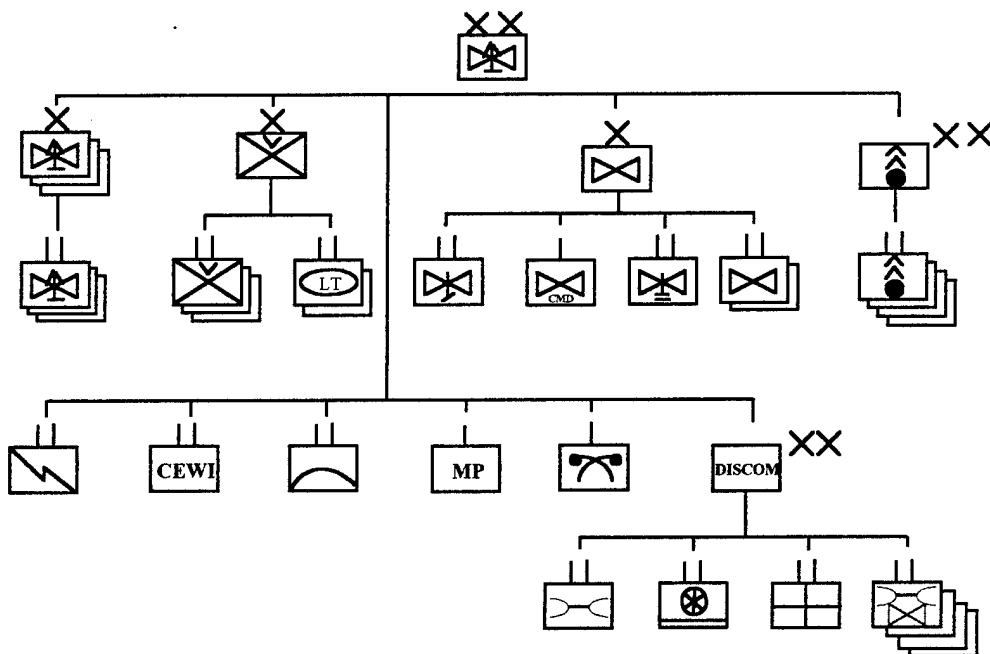

Figure 5.

attack."<sup>70</sup> Today, the AH-64 APACHE and the projected RAH-66 COMANCHE come very close to meeting the requirements von Senger and Etterlin outlined for his MBAV.<sup>71</sup>

Von Senger und Etterlin envisioned his 'airmechanized division' primarily as an operational reserve, particularly suitable to NATO's central region as it faced the Warsaw Pact threat.<sup>72</sup> This is not surprising considering his position at the time. His concept was to launch the division from 200-300 kilometers to the rear to counter penetrations by armored forces, particularly Soviet operational maneuver groups. By staging the force far to the rear, he sought to provide it protection while it was stationary. When an armored penetration developed, the 'airmechanized division' would attack to destroy the enemy's mobile formations, countering their mobility with even greater mobility. In this way, von Senger and Etterlin believed he could negate the advantage of interior lines gained by an attacker once he has achieved a penetration.<sup>73</sup>

In 1990, the U.S. Army began studying the concept of consolidating aviation assets. The 1990 AirLand Battle Future: Alternate Case Study (Phase 1) looked at consolidating aviation assets, particularly attack helicopters, at the corps level.<sup>74</sup> Later, the United States Army Aviation Center did some studies into the potential of an Air Attack Division. It consisted of three attack helicopter brigades, a general support aviation brigade, an air assault infantry brigade, and a division artillery. It also included a division support command and signal, military intelligence, air defense, military police, and chemical units.<sup>75</sup> Only a limited amount of research was done on the organization, however, before the study was discontinued (see figure 5.).

#### D. Relooking Airmechanization.

Currently, a number of factors favor a reexamination of the potential of an airmechanized division. First, the Army is fielding a new generation of helicopters with greatly increased capabilities. Second, information technologies are projected to open up new dimensions in warfare

in the 21st century, requiring more agile, responsive forces. The Army's vision of 21st century warfare also demands formations capable of providing greater simultaneity and depth. Finally, the Army is currently undergoing radical change in its force structure anyway, presenting an opportunity to introduce new organizations without creating a great amount of turbulence.

At the time Simpkin and Von Senger und Etterlin developed their concepts, the Army had just begun fielding its newest generation of helicopters. Units were beginning to receive the new UH-60 BLACKHAWK, a replacement for the Vietnam-era UH-1 HUEY. The AH-64A APACHE was still in its infancy and the RAH-66 COMANCHE was nothing more than a concept known as LHX (light helicopter, experimental). Now the UH-60 and AH-64 fleets are fielded and the RAH-66 is in product development. In addition, a number of modernization programs are on-going that will significantly upgrade the already impressive capabilities of the BLACKHAWK and APACHE. These aircraft are significantly more mobile, lethal, and survivable than their predecessors. They are much more capable of fulfilling the visions of Simpkin and Von Senger und Etterlin than the helicopters that inspired these men.

New information technology, as well as new helicopter technology, is another reason to relook airmechanization. The Army expects information technology to improve dramatically in the early 21st century. It will "... greatly increase the volume, accuracy, and speed of battlefield information. ..."<sup>76</sup> The expectation is that battle command processes will be refined and quickened by the new information technology. The Army will need organizations that can respond with corresponding speed and agility in order to capitalize on the enhanced battle command potential. It will also require organizations with the speed and agility to stay ahead of the enemy's battle command capabilities. Airmechanization promises this increased speed and agility.

The future battlefield will also require organizations capable of providing greater simultaneity and depth to operations. The Army's vision of the future battlefield is one of greatly expanded

dimensions. Formations will be dispersed throughout an extended battlespace, concentrating only for brief periods of time and rapidly dispersing again.<sup>77</sup> Domination of the future battlefield will require organizations with ". . . agile and robust deep and simultaneous attack capabilities."<sup>78</sup>

Airmechanization promises these capabilities.

Finally, the Army is currently undergoing radical, turbulent change in the aftermath of the Cold War. Its force structure is shrinking while the demands on it increase. Maintaining a smaller version of itself does not appear to be the answer to meeting the challenges of the early 21st century. Instead, organizations must be reshaped to provide greater agility, lethality, and survivability.<sup>79</sup> Airmechanization promises one avenue to achieve this.

## IV. Modern Airmechanization: The Aviation Strike Force

### A. General.

The 'airmechanized division' examined in this monograph is only one of many potential organizational structures. It is intended as a representative model in order to evaluate the concept of using a helicopter-based force in deep operational maneuver. Some of the basic inspiration for this organization comes from the Mobile Strike Force (MSF), one of the U.S. Army Training and Doctrine Command's FORCE XXI initiatives. The MSF is a "... conceptual, fully digitized, heavy division equipped with technologies and systems projected to be available at or near the beginning of the 21st century."<sup>80</sup> It was designed to be a deep operational maneuver force, capable of maneuvering to depths of 300 kilometers while sustaining itself for up to five days.<sup>81</sup> The force examined here is an aviation equivalent of the MSF, an Aviation Strike Force (ASF).

### B. Designing the Aviation Strike Force.

Like the deep operational maneuver formations of Tukhachevskiy, Triandafillov, Fuller, and Guderian, the basic requirement of the ASF is superior mobility. Based on the concepts of Simpkin and Von Senger und Etterlin, it will rely on the helicopter to provide it the mobility differential essential to deep maneuver forces. The ASF is envisioned as an air- and ground-based, combined arms formation. To capitalize on the superior mobility of the helicopter, however, most of its ground-based elements will be helicopter transportable. The intent is to ensure that all elements that the ASF projects in deep maneuver capitalize on the mobility differential provided by its helicopters.

The entire ASF is not expected to move into the enemy's depths. Instead, it will use split-based operations to project a force forward that is mostly 'teeth' with a minimum of 'tail' to encumber it.

Under the FORCE XXI concept, such split-based operations will be standard for Army divisions. Significant elements of both the command and control and logistics systems will operate in this manner.<sup>82</sup> It is projected that burgeoning information technology will enable these and other operating systems to exploit the advantages of split-based operations.

Like the MSF, the design of the ASF is limited to systems and technologies that are projected to be available to the Army by the early 21st century. It is assumed that such a force would be fully digitized and capitalize fully on available information technologies. Systems that would be ideal for the ASF, but are not projected to be available, will be noted. The impact of having these systems will be examined as part of the analysis of the force.

The organizational designs of the ASF's subordinate units mirrors existing or projected force structures, where possible. In the case of aviation units, the Aviation Restructure Initiative (ARI) interim or objective organizations were adopted. It was assumed that these new structures were designed to correct tactical deficiencies and address force structure realities beyond the scope of this monograph. In addition, using these and other existing organizational designs simplified support and sustainment analysis.

### C. Organizational Structure (see figure 6).

#### Combat Elements

The primary combat elements of the ASF are an air reconnaissance regiment, two attack helicopter brigades, and an air assault infantry brigade. The air reconnaissance regiment consists of two air reconnaissance squadrons (ARS), patterned after the Aviation Restructure Initiative's interim version of the air assault division ARS. Instead of the OH-58D KIOWA WARRIOR, however, each squadron is equipped with 32 of the more advanced RAH-66 COMANCHE.<sup>83</sup> The air reconnaissance regiment is the ASF's primary reconnaissance and surveillance element. The

## Aviation Strike Force: Organizational Structure

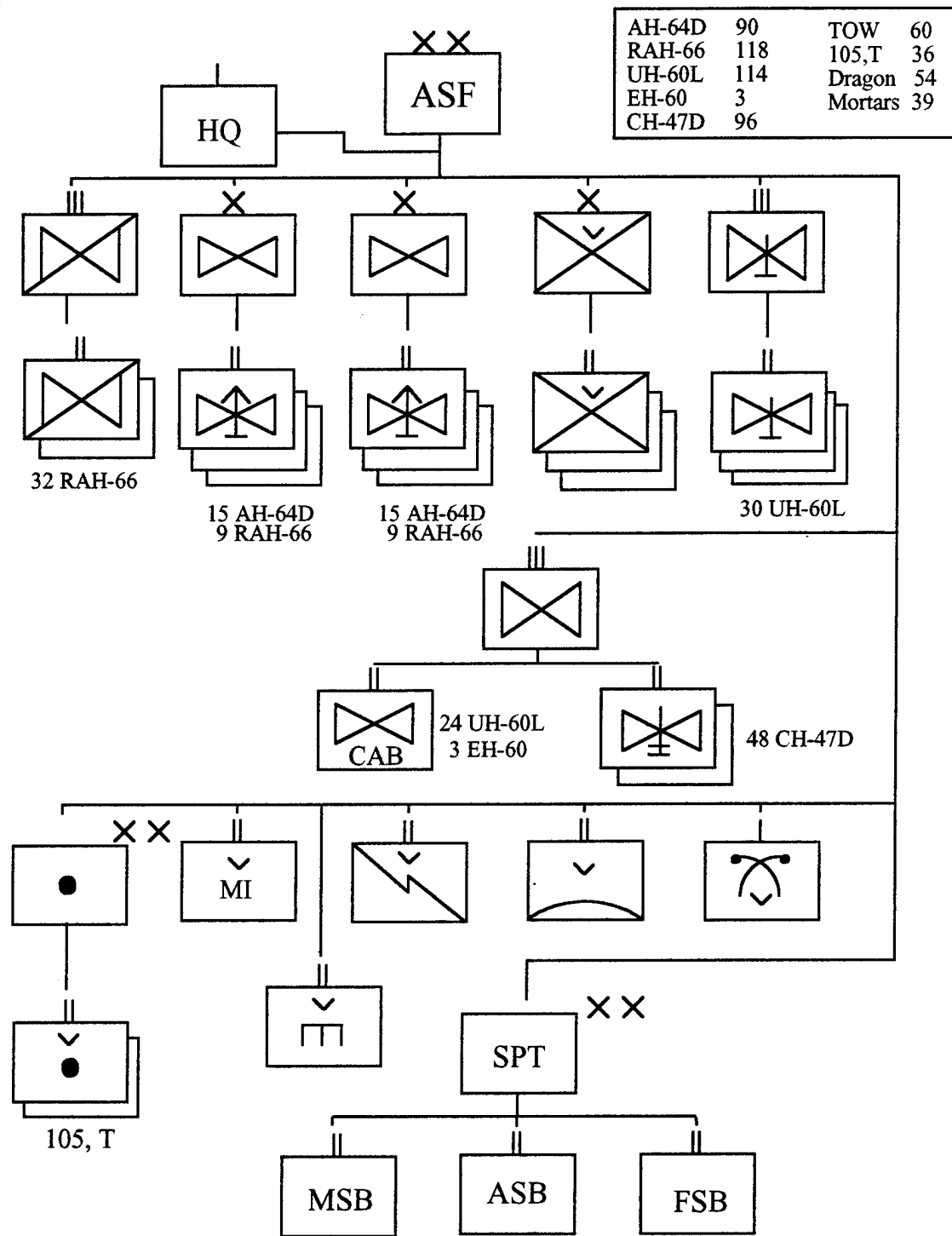

Figure 6.

regiment also conducts security operations, providing air assault escorts and aerial screens for the force. Additionally, the regiment provides the ASF potent counter air and suppression of enemy air defense (SEAD) capabilities with the COMANCHE<sup>84</sup>. As a secondary role, the air reconnaissance regiment can act as an additional attack helicopter brigade, when necessary. Organizing the regiment with two ARS enables it to conduct continuous, distributed operations throughout the ASF's expanded battlespace.

The two attack helicopter brigades each consist of three attack helicopter battalions (ATKHBs). Each battalion is organized under the ARI's air assault division ATKHB objective structure with 15 AH-64D APACHES and 9 RAH-66 COMANCHEs.<sup>85</sup> Additionally, each battalion is equipped with nine LONGBOW systems. These systems greatly improve the lethality and survivability of the ATKHB, making these units the ASF's most potent combat elements.<sup>86</sup> The primary role of the attack helicopter brigades is to destroy enemy mechanized forces and materiel. Their secondary role is reconnaissance and security. Like the ARS, these ATKHBs possess effective SEAD and anti-air capabilities. The attack helicopter brigades are organized to provide the ASF with the flexibility to employ its attack helicopter in mass, continuous, or distributed operations, as necessary.

The air assault brigade is identical to those currently fielded in the 101st Airborne Division (Air Assault). It consists of three air assault infantry battalions. In the ASF, this brigade will play a number of roles. These will include conducting raids against critical enemy facilities and forces, seizing key terrain in order to interdict the movement of forces or supplies, securing the ASF's forward operating bases, and reinforcing the ASF's reconnaissance efforts. Perhaps the most essential role will be to act as the 'anvil' for the attack helicopter brigade's 'hammer' to destroy enemy formations. A multi-role force, the air assault brigade will be pivotal to the ASF's operations.

Ideally, this brigade should be equipped with a means of secondary mobility such as a light armored fighting vehicle. Echoing Tukhachevskiy's and Fuller's arguments for mechanizing airborne infantry, Simpkin argued for providing airmobile infantry with secondary mobility to maintain a high tempo of operations once they were inserted. Unlike the Soviets with their BMD airborne assault vehicles and their MI-26 heavy lift helicopters, the U.S. Army has no suitable vehicle capable of being transported by its helicopters.

#### Combat Support

The fourth major aviation element of the ASF is the assault helicopter regiment. It consists of three assault helicopter battalions. Each battalion is configured in the ARI objective organization with 30 UH-60 BLACKHAWK helicopters. The regiment's primary role is to support air assault operations as part of an air assault task force. Additionally, it supports air movement operations with its utility helicopters. In a secondary role, it may act as an aviation maneuver headquarters if task organized with reconnaissance or attack helicopters.

The final aviation element of the ASF is an air transport regiment. It consists of a combat aviation battalion and two medium lift battalions. Both battalion types are the ARI air assault division objective versions.<sup>87</sup> The command aviation battalion is equipped with 24 UH-60 BLACKHAWK and 3 EH-60 QUICKFIX helicopters. It provides air movement, command and control enhancement, and special electronic mission aircraft support to the ASF. The medium lift battalions each contain 48 CH-47Ds and provide the ASF's primary air movement support. The air transport regiment is the ASF's largest aviation element, controlling 123 of the force's helicopters. Its primary role is to manage the utilization of the ASF's utility and cargo helicopters.

The ASF's division artillery (DIVARTY) consists of two airmobile artillery battalions. Each battalion is equipped with 18 M119A1 105mm, towed howitzers. The primary role of these battalions will be close support to the air assault brigade. They will also conduct artillery raids in

support of the attack helicopter brigades and the air reconnaissance regiment. When required, the ASF will use its attack helicopter assets in an aerial fire support role to augment DIVARTY. An ideal system to equip the DIVARTY with would be a helicopter-transportable multiple launch rocket system (MLRS) with capabilities similar to the present version. This would provide the ASF with significantly increased ranges for its supporting artillery.

The ASF also includes a military intelligence battalion, a signal battalion, an engineer battalion and air defense artillery battalion and a chemical company (smoke/decon). They are each organized generally along the lines of current air assault division assets, so they are configured for airmobile operations.

#### Combat Service Support

The ASF's division support command (DISCOM) consists of a main support battalion (MSB), three aviation support battalions (ASB), and a forward support battalion (FSB). Each battalion fills a role similar to current doctrine. The ASBs primarily support the two attack helicopter brigades and the air transport brigade. The air reconnaissance regiments coordinates support through the nearest ASBs and the MSB. The FSB supports the air assault brigade. The ASF relies heavily on split-based logistics operations in order to reduce the 'tail' of the force when it maneuvers in the depths of the enemy's positions.

**V. The Aviation Strike Force in Deep Operational Maneuver--**  
**A Critical Analysis**

A. General.

The ASF will be analyzed in this section to determine its viability as a deep operational maneuver force. The analysis will begin with an examination of the ASF's characteristics and capabilities, focusing on mobility, firepower, and protection. The force's potential employment will be analyzed to determine how well the ASF enhances the 'imperatives' of simultaneity, depth, and tempo. In conjunction, the ASF's support and sustainment requirements will be identified to determine some of the 'costs' of employing such a force.

B. Characteristics and Capabilities.

Tukhachevskiy, Triandafilov, Fuller, and Guderian all proposed deep operational maneuver forces with a special blend of mobility, firepower, and protection. The primary characteristic of their forces was a high degree of mobility, resulting from superior speed, range, and movement capabilities. The requirement was to possess a mobility advantage an 'order of magnitude' over that of the bulk of the enemy's forces.<sup>88</sup> This mobility advantage was critical for dominating maneuver in the 'deep operation.' Firepower and protection were subordinated to mobility; a risk the theorists accepted because they assumed the enemy's rear would be more vulnerable and less lethal than his front. Even with reduced firepower and protection, the deep maneuver formations retained the lethality and survivability they needed to operate in the enemy's operational depths. An examination of the ASF's characteristics and capabilities indicates that it possesses the proper blend of mobility, firepower, and protection.

## Mobility

The ASF is designed to operate with entirely helicopter-mobile combat formations when maneuvering deep. The combat elements of the air reconnaissance regiment and the attack helicopter brigades are inherently helicopter-mobile. In addition, the ASF can simultaneously move a 1,300-man air assault task force, an artillery battalion, and up to 560 short tons of supporting equipment and supplies by helicopter.<sup>89</sup> This force is roughly equivalent to a heavy division in relative combat power.<sup>90</sup> The ASF's helicopters enable the force to move generally unhindered by the terrain, providing the force superior mobility.

Compared to the combat formations of a heavy division, the ASF's combat elements have a distinct advantage in speed. The slowest of the ASF's helicopters is the AH-64 APACHE, with a cruise speed of 268 kilometers per hour (kph).<sup>91</sup> Considering that the combat formations are entirely helicopter-mobile, it is not unreasonable to expect them to attain speeds of over 200 kph, even when moving in large formations. The maximum speed for the M1 ABRAMS tank and the M2 BRADLEY infantry fighting vehicle is roughly 66 kph.<sup>92</sup> The average speed for planning of a heavy division roadmarching is only 32 kph.<sup>93</sup>

While there is a vast differential in speed between the ASF and a heavy division, they have roughly the same unrefueled range. The cruising range of an AH-64, the shortest distance of all the ASF's helicopters, is just over 400 kilometers (although this may be extended with auxiliary fuel tanks).<sup>94</sup> The cruising range for an M1 is over 450 kilometers.<sup>95</sup> Although they have similar ranges, the mobility differential between the ASF and a heavy division begins to stand out when one considers that the ASF can move 400 kilometers in about 3 hours while a heavy division would require in excess of 17 hours.<sup>96</sup>

As a helicopter-mobile force, the ASF has both advantages and disadvantages in movement capabilities when compared to a heavy division. The primary advantage of the ASF is that it can

move generally unhindered by terrain because it exploits the aerial dimension for its movement. This gives the ASF a significant capability to mitigate or overcome a wide variety of natural and man-made terrain-based obstacles. Most significantly for deep maneuver, the ASF has the ability to pass over operational obstacles such as hilly or forested regions, lakes and swamps, rivers, and major urban areas. The ASF also has the potential to pass over areas of chemical contamination forming obstacles to ground movement.<sup>97</sup> This ability can give the ASF access to the enemy's operational depths while it is denied to a heavy division.

Moving in the aerial dimension also gives the ASF the ability to reduce its movement times by minimizing travel distances and pass times. The ASF may travel 'as the crow flies' while a heavy division is bound to roads or to the dictates of terrain. Additionally, the ASF is not constrained by the availability of movement routes. In essence, the aerial dimension provides a multitude of routes, enabling the ASF to reduce its pass time drastically. These capabilities can be used to enhance the agility and increase the tempo of the ASF's operations.<sup>98</sup>

A disadvantage of the ASF is that it cannot terminate its movement in an area that does not provide suitable landing areas. In order to operate in an area for extended periods, the ASF must establish forward area rearming and refueling sites. These require landing areas of the proper dimensions. Additionally, adequate landing zones must be available for emplacing the air assault task force and the artillery battalion.<sup>99</sup>

Another significant disadvantage of the ASF is that it is vulnerable to climatological 'obstacles' produced by severe weather. The Army's modern helicopters have substantial capabilities for operating at night and in adverse weather, but they are not yet all-weather capable. As a result, weather conditions that would not have a significant impact on a heavy division's operations could significantly hamper the operations of the ASF. While weather 'obstacles' are usually of a transient nature and normally tactical in effect, unfortunate timing can give them operational significance.

Although the ASF has both advantages and disadvantages in certain elements when compared with a heavy division, overall it possesses a significant mobility advantage over its ground-based counterpart. Its speed, range, and movement capabilities combine to give it an agility superior to that of the heavy division. Assuming that the bulk of an enemy's force will be mechanized, the ASF possess the mobility differential required of a deep operational maneuver force.

#### Firepower

The ASF cannot match a heavy division in terms of sheer volume of fire. It contains roughly 300 major direct-fire weapon systems where a heavy division has over 750. Additionally, the ASF only possesses 75 indirect-fire systems while a heavy division has over 140.<sup>100</sup> As noted earlier, however, the ASF has roughly the same relative combat power as a heavy division. The strength of the ASF is that over 200 of its direct-fire systems are precision-guided weapons. The ASF's RAH-66s and AH-64s can bring over 1,400 laser- and millimeter wave radar-guided missiles into the fight.<sup>101</sup> With its superior mobility, the ASF can concentrate its fires against the enemy much more quickly than a heavy division. Coupled with the improved accuracy of battlefield information and near real-time sensor-shooter links promised by future information technology, these capabilities will make the ASF a highly lethal force, both in the enemy's operational depths or at his tactical defensive front.<sup>102</sup>

A limitation of the ASF is that requires relatively open terrain on which to fight. Its precision-guided weapons would be relatively ineffectual in dense jungle or heavily wooded terrain where targets cannot be designated by either laser or millimeter wave radar. Additionally, the ASF is not well suited to fighting light infantry forces. It is well suited for fighting mechanized forces, which usually operate on terrain suitable for the ASF's weapon systems. It is also fully capable of destroying command and control and logistic facilities and equipment, as well as assets and materiel associated with other battlefield functions such as fire support and integrated air defenses.

## Protection

Perhaps the greatest weakness of the ASF is the relative vulnerability of its aircraft.

Helicopters trade the weight of armored protection for the advantages of moving in the aerial dimension. The Army's new generation of helicopters, however, have made significant improvements in protection. New composite airframe materials have improved ballistic protection without adding weight. Redundant systems give the aircraft greater durability. Although these helicopters are more rugged, their best protection is to avoid detection and engagement. Low observable materials and designs greatly reduce the visual, audio, thermal, and radar signatures of the aircraft. Threat warning systems and countermeasures have been greatly improved, especially in the wake of Operation Desert Storm. Improved pilotage systems enable better performance at night, allowing the aircraft to routinely operate in an environment where threat systems' capabilities are reduced. Significant advances in weapon systems allow attack and scout helicopters to acquire and engage threat formations faster, with improved accuracy, and greater standoff. The speed and mobility of the helicopter also play a major role in enhancing its survivability, enabling the crew to reduce the enemy's acquisition and engagement opportunities.

In all, the survivability of the ASF compared to a heavy division is analogous to the survivability of the mobile exploitation formations compared to the breakthrough forces. The ASF is not designed to trade blows with an enemy force. Instead, it is designed to deliver a devastating blow to the enemy while avoiding his counterstrokes. It relies on its mobility to allow it to concentrate and disperse rapidly, denying the enemy the opportunity to strike decisively. In the enemy's tactical and operational depths, where he will lack the concentration of combat units and density of air defenses of the tactical front,<sup>103</sup> the ASF should be sufficiently survivable.

### C. Employing the Aviation Strike Force.

With its ability to maneuver in the aerial dimension, the ASF opens up new options in deep maneuver for the operational commander. It provides him with a degree of flexibility that other deep maneuver forces do not. He can use the ASF to significantly enhance the simultaneity, depth, and tempo of his 'deep operations.'

Unlike ground-based deep operational maneuver formations, the ASF can provide operational simultaneity and depth from the outset of an operation. In a classic 'deep operation,' when no open flanks existed, the ground-based operational exploitation forces had to wait until a breach was opened in the defensive front before they could attack to operational depths. Only after the tactical defenses were penetrated and the mobile formations committed did the operation truly gain operational simultaneity and depth. Prior to this point, the entire focus was on the tactical defensive front. The ASF, however, is not hampered by the need for a physical breach through the enemy in order to move to operational depths.

If the enemy's flanks are tied into tactical or operational obstacles which deny ground movement or maneuver, it is likely that the ASF will be able to exploit these obstacles to gain access to the enemy's operational depths. Since the ASF can overcome a wide spectrum of terrain-based obstacles, the enemy's flank would be virtually open to maneuver by the ASF. This, of course, would be the preferred way to reach the enemy's depths since it would avoid the strength of the enemy's tactical defenses.

If no 'virtual' open flank exists, the ASF can conduct an aerial penetration of the tactical defensive front in order to reach operational depths. While this would be a high risk operation, it would not require the time nor the assets necessary to conduct a penetration on the ground. The enemy's defenses must be suppressed in the vicinity of the axes of aerial penetration during the operation, however, there is no need to physically breach his positions. An aerial breach would

still require a considerable dedication of assets, however, the basic techniques have already been developed in current U.S. Army deep attack procedures.

While the ASF gives the operational commander a force that he can get deep early, he may elect not to commit it right away. He may, instead, use the threat posed by the ASF to influence the enemy commander as either a deception or a deterrent. As a deception, the commander can position the ASF on one part of the battlefield to induce the enemy to react by preparing against an attack by the force. He can then shift to another area for launching the actual attack, moving quicker than the enemy can respond. Used as a deterrent, the operational commander may position the ASF to induce the enemy commander to not commit forces to a certain area or to hold them in position.

If committed early in the operation, the ASF will probably begin its operations with attacks to upset the coherence and tempo of the enemy's operations. A likely scenario is for the ASF to penetrate approximately 200 kilometers into the enemy's depths and establish a forward operating base in an area secure from immediate attack. From such a position, the ASF can threaten over 196,000 square kilometers, including a considerable portion of the enemy's tactical rear and his operational depths up to approximately 450 kilometers.<sup>104</sup> Such a position also allows immediate withdrawal of the force if necessary. The forward operating base would be temporary in nature, providing an area for forward area rearm points (FARPs), emergency maintenance teams, and assembly areas for reserves. The ASF would launch attacks from these bases against critical operational functions, formations, and resources.

The ASF could begin unraveling the enemy's coherence and tempo by attacking the elements of critical operational functions. It can upset command and control by destroying key command posts and signal assets. It can degrade sustainment by interdicting lines of communication, either by dominating terrain or destroying distribution assets. It can further upset the enemy's sustainment

by destroying key logistics bases. The ASF can also attack the enemy's fires by destroying long-range artillery assets or raiding operational airfields. Additionally, the force can enable operational attack by Air Force assets by destroying functional systems such as early warning and integrated air defense assets.<sup>105</sup>

During these operations, the ASF will probably operate in a distributed manner, with the different brigades executing independent missions. This is due to the likely dispersion of the enemy's assets in his operational depths. In these operations in particular, the ASF will rely heavily on the near real-time sensor-shooter links promised by future information technology. Critical targets must be identified precisely and acted upon in a timely manner. To keep the enemy off-balance, the ASF will continually threaten different portions of the battlefield, using its agility to dominate the tempo of operations.

One possible focus for the ASF's operations would be to assist in the breakthrough of the tactical defensive front. It could direct its operations so that the effects impacted primarily on that portion of the enemy's defensive front where the penetration was intended. When necessary, the ASF could shift its attacks to contain or destroy the enemy's tactical reserves in order to ensure the success of the breakthrough.

A more decisive focus would be the containment or destruction of the enemy's operational reserves.<sup>106</sup> The ASF's initial operations would be geared to drawing the enemy's reserve formations out of their positions. Once moving, these formations become more vulnerable to attack by the ASF. By integrating his operational fires with the actions of the ASF, it is possible that the operational commander can destroy an enemy's operational reserves without having to penetrate an enemy's forward defenses and commit exploitation forces.

#### D. Supporting the Aviation Strike Force.

The ASF will require considerable support from the operational commander when committed to deep operational maneuver. It will require intelligence support in order to maneuver and attack effectively, as well as for protection. Additionally, the ASF will require the support of operational fires to complement its maneuver by exploiting the interchangeability of forces and fires. It will also require assets dedicated to its protection, offsetting some of the ASF's vulnerability while operating deep.

#### Intelligence

The capabilities of the ASF's intelligence assets are purely tactical. It will rely on corps and higher assets when conducting deep maneuver. Typically, the ASF will operate beyond the ranges of corps assets, necessitating a heavy reliance on echelons above corps resources. While the intelligence seamless "system of systems" should make the actual collection process invisible to the ASF, the operational commander will have to direct that assets be dedicated to supporting its mission. Before committing the ASF, the operational commander's intelligence system must develop the enemy situation, identify potential hazards, and develop target information. It must continue to develop and track targets from the time of commitment of the ASF until the force executes the engagement. The intelligence system must also develop indicators and warnings to help protect the ASF and enable it to retain the initiative. This will require theater assets such as the Joint Surveillance Target Attack Radar System (JSTARS) and access to national systems to provide the necessary information. A critical facet of this support will be developing responsive sensor-shooter links between collection assets and the combat formations of the ASF.

In return, the ASF can enhance the operational commander's intelligence system by providing battlefield information from the enemy's operational depths. The air reconnaissance regiment and

the attack helicopter brigades should prove to be highly effective reconnaissance assets. Thus, the ASF will be an integral part of the commander's deep operations collection plan.

#### Fires

The ASF will typically operate well beyond the range of supporting fires normally available to a division. Shorter range systems can be used to assist the ASF in aerial penetrations of the enemy's tactical defenses, however, due to range limitations these fires will be limited to the vicinity of the forward line of troops. Once beyond tactical ranges, the ASF will rely on assets such as Army Tactical Missile System (ATACMS) and tactical air forces (TACAIR) for lethal fire support. It will also have to rely on TACAIR for electronic warfare support beyond its organic capabilities. As with the intelligence system, the ASF will need responsive links to fire support assets that can range its targets.

The ASF can also enhance the effectiveness of operational fires. It can provide 'eyes on' confirmation of targets and assist with fire control to ensure greater accuracy in engagements. Additionally, it can help provide timely battle damage assessment. As with the intelligence system, the operational commander should ensure integration of the ASF with his operational fires system.

#### Protection

The operational commander must plan to provide air defense protection to the ASF. Although the force will operate beyond the coverage of most air defense assets, systems such as the Theater High Altitude Air Defense System (THAAD) and the Patriot Advanced Capability-3 (PAC-3) will be able to provide some coverage if positioned properly. TACAIR assets will have to provide additional counter air protection. It is likely that air superiority will be a prerequisite prior to ASF commitment. Without it, the operational commander incurs a magnified risk to the ASF.

#### E. Sustaining the Aviation Strike Force.

Sustainment is undoubtedly the ASF's 'Achilles' heel.' Logistical support of the organization, especially with current and projected combat service support assets, will be difficult. Two particularly critical items will be fuel and ammunition. An examination of these two classes of supply indicates that the ASF's logistic requirements will put unique strains on the operational commander's sustainment system.

A rough estimate of the fuel requirements for the ASF indicate that it will consume nearly 460,000 gallons of bulk fuel daily.<sup>107</sup> This is less than a heavy division's 503,000 gallons per day,<sup>108</sup> but the heavy division does not need to transport its fuel into the enemy's operational depths before ground lines of communication are opened. Actually, the ASF will put less overall strain on the sustainment system than will a heavy division, except for the problem of distribution to the forward combat elements. These supplies will have to be delivered by air.

Of the ASF's 460,000 gallon per day requirement, its forward elements will require a minimum of 192,000 gallons per day.<sup>109</sup> The ASF also requires approximately 494 short tons of ammunition daily.<sup>110</sup> Combining its ammunition and fuel requirements, the ASF's forward combat formations would need 1146 short tons of supplies delivered daily.<sup>111</sup>

With its organic helicopters the ASF can lift 1124 short tons at one time. If it is possible to transit back and forth between the enemy's operational depths and the ASF's rearward supply bases with acceptable risk, the ASF could supply itself easily. However, the risk of constant transit by a large number of helicopters may not be acceptable. Other options are available for the operational commander to keep the ASF supplied while in the enemy's operational depths. Air delivery of supplies using intra-theater airlift assets is one possibility. The ASF would require approximately 115 C-130 equivalents daily.<sup>112</sup> This option, too, entails risk for the delivery aircraft.

Developments such as the Advanced Precision Airborne Delivery System (APADS), however, will

decrease the vulnerability of these aircraft and increase the accuracy of airdropped supplies. This system enables aircraft to make high-altitude, offset airdrops with an accuracy of 100 meters.<sup>113</sup> In either case, helicopter or air-lift delivery, air superiority will be critical.

In general, while the ASF will pose some unusual problems for the sustainment system, it can be supplied at operational depths. While risks are incurred, they must be weighed against the potential gains that the ASF can achieve in the enemy's operational depths. The ability to sustain the ASF at operational depths will determine how the ASF can be employed in deep operational maneuver. If adequate supply cannot be maintained, it will be limited to operational raids of short duration and limited depth. The ASF will lose the endurance it needs to fully exploit the vulnerabilities of the enemy's operational rear. One caution the ASF should observe at all times is to maintain enough fuel on hand to withdraw to friendly territory. Unlike a heavy division or airborne forces, the ASF retains the capability to quickly withdraw from the enemy's operational depths if its position becomes untenable.

## VI. Conclusions

### A. Thor's Hammer.

Within the limits of this study, an Aviation Strike Force appears to be a viable concept for a deep operational maneuver force. In general, it appears to meet the balance of mobility, firepower, and protection that theorists such as Tukhachevskiy, Triandafillov, Fuller, and Guderian believed critical for such formations. Its high degree of mobility can expand the operational commander's maneuver options in simultaneity, depth, and tempo for his 'deep operations.' The ASF links the relative combat power of a heavy division with freedom of maneuver in the aerial dimension to forge a highly lethal force. It blends mobility, physical protection, and firepower to ensure survivability in deep operational maneuver. Its capabilities allow the operational commander to achieve simultaneous action in the enemy's operational depths sooner than with ground-based formations. The ASF's mobility and inherent flexibility provides for a potential tempo of operations that is unmatched by either a heavy or airborne division.

Sustainment while at operational depths will be the weakest link and pose the greatest challenge for the ASF. The force will consume a substantial quantities of fuel and ammunition in its operations, though less than current heavy divisions. Delivering these supplies to the ASF while it is at operational depths will be a challenge, and probably the greatest limitation on its employment possibilities. In a worst case scenario, the ASF will be limited to raiding operational depths, striking quickly and then withdrawing to a source of resupply. Still, the force will represent a significant threat to the enemy's vital assets across a significant breadth and depth of his dispositions. This will force the enemy commander to choose between trying to protect his assets everywhere the ASF could strike (thus diluting his combat power throughout) or leaving critical assets vulnerable to attack.

In Norse mythology, Thor wielded the most powerful weapon of the gods, the hammer Mjolnir. With this weapon, Thor would strike his enemy's from great distances by throwing it with great accuracy and with deadly effect. After it had struck its target, the hammer would then return to Thor's hand, ready to be thrown again. The ASF could be such a tool for the operational commander. With it, he could strike devastating blows against the depths of the enemy, have it return, and quickly strike with it again in some new location.

#### B. Constituting an Aviation Strike Force.

As envisioned, the ASF could be either a standing organization or a formation akin to the German *kampfgruppe* of World War II. From the standpoint of command and control, training, logistics, cohesion, and other operational factors, the standing unit would be preferred. From the standpoint of fiscal and force structure costs, this may not be the preferred, or even feasible, option. The *kampfgruppe* approach provides a way to exploit the ASF concept, even if a standing force cannot be created.

The *kampfgruppe* were ad hoc organizations ranging in size from small detachments to division-sized formations. They were normally formed to fulfill independent missions of special importance, requiring a mix of capabilities not found in a single standing organization. Usually, a principal unit formed the 'nucleus' of the *kampfgruppe*, providing the basic cohesion and control for the entire formation. These organizations were highly successful during World War II, despite their ad hoc status, and provided the Germans a significant dimension of flexibility.<sup>114</sup> In fact, this concept is in line with the Army's FORCE XXI concept which envisions "rapidly tailoring organizations to operate within any potential contingency situation. . . ."<sup>115</sup>

Whether a standing force or an ad hoc organization, the most likely candidate in the current Army force structure to form the nucleus of the ASF is the 101st Airborne Division (Air Assault).

Under the Aviation Restructure Initiative, it will already possess over 60 percent of the aircraft allotted to the ASF. It also possesses much of the rest of the force structure envisioned for the ASF. Reinforced with a corps aviation brigade, the division could easily form an ASF. This will require, however, a mental shift in its focus from the employment of its three ground brigades with integrated aviation support to employment of its aviation assets with integrated ground support.

### C. Materiel Development.

There are several areas of materiel development that would greatly strengthen the viability of an ASF. One of the most obvious is developing improved means of safely and efficiently delivering the necessary supplies to the ASF while in the enemy's depths. This will provide the force a more robust endurance and a better potential for making an operational impact. Developmental systems, such as the Advanced Precision Airborne Delivery System, are currently addressing some of these needs. In the long term, reducing the fuel consumption of the air vehicle--through more efficient power plants or advanced power sources--will be one of the keys to transitioning to the era of air- and ground-based combined arms units. Another key area is developing a means of secondary mobility for the ground-based portion of the ASF once they dismount from the air vehicles. This will improve the overall tempo of the ASF and should not require any significant technological breakthroughs as many suitable light, armored vehicles exist today. Additionally, further developments in aircraft survivability equipment and increasing the ruggedness of the air vehicles, will also improve the viability of air- and ground-based formations. Continued 'digitization' of the battlefield will be also crucial. The promise of information technologies will be the key that unlocks the potential of large air- and ground-based formations.

#### D. Further Study.

The concept of the ASF appears to hold promise for the U.S. Army as it enters the 21st century. It offers one potential avenue for meeting the challenges of the battlefield envisioned in the near future, opening up new dimensions for operational maneuver. Before selecting this avenue, however, it requires further study. The scope of this study was rather narrow, limited to the operational level potential of the ASF in deep operational maneuver and based on the requirements of some of the seminal theorists on modern deep operational maneuver. Both the operational and tactical possibilities and liabilities of such a force need to be studied in greater depth and detail. Additionally, the fiscal and force structure costs of such a force must be explored more fully. Each aspect of the ASF concept must be explored to determine if it is the type of force that can meet all the demands of the 21st century battlefield.

<sup>1</sup> TRADOC Pamphlet 525-5, Force XXI Operations: A Concept for the Evolution of Full-Dimensional Operations for the Strategic Army in the Early Twenty-First Century (Fort Monroe, VA: Headquarters, TRADOC, August 1994), pp. 2-7 to 2-8.

<sup>2</sup> Ibid., p. 4-5.

<sup>3</sup> Ibid., p. 4-6.

<sup>4</sup> Ibid., p. 2-9.

<sup>5</sup> Ibid., pp. 3-10 to 3-12.

<sup>6</sup> United States Army Aviation Center, Aviation Restructure Initiative: Foundation for the Future (Fort Rucker, AL: USAAVNC, February 1994), pp. 10-73. This statement refers primarily to active duty aviation units. Many aviation brigades retain the same structure, or even increase in size, but more units belong to the reserve component or are unfunded requirements. The number of active duty aviation battalions dwindles significantly.

<sup>7</sup> Gordon R. Sullivan, "Land Warfare in the 21st Century," Military Review, September 1993, p. 27.

<sup>8</sup> Field Manual 100-5, Operations (Washington, D.C.: HQDA, 1993), p. 2-5.

<sup>9</sup> Ibid., p. 2-10.

<sup>10</sup> Ibid., p. 2-13.

<sup>11</sup> Ibid., p. 6-14.

<sup>12</sup> Christopher Bellamy, The Evolution of Modern Land Warfare (London: Routledge, 1990), p. 80.

<sup>13</sup> Ibid.

<sup>14</sup> Richard E. Simpkin, Red Armour: An Examination of the Soviet Mobile Force Concept (Oxford, England: Brassey's Defence Publishers, 1984), p. 142.

<sup>15</sup> Richard E. Simpkin, Deep Battle: The Brainchild of Marshal Tukhachevskii (London, England: Brassey's Defence Publishers, 1987), p. 33.

<sup>16</sup> Red Armour, p. 139.

<sup>17</sup> Ibid., pp. 197-198.

- <sup>18</sup> Ibid. pp. 198, 225.
- <sup>19</sup> Ibid., p. 171.
- <sup>20</sup> Mikhail Tukhachevskiy, "New Problems in Modern Warfare," unpublished manuscript, 1931. Printed in Art of War Colloquium (Carlisle, PA: USAWC, 1983). Reprinted in Advanced Military Studies Program Course 1 Readings, Foundation of Military Theory (Fort Leavenworth, KS: USACGSC, undated).
- <sup>21</sup> Ibid., p. 13.
- <sup>22</sup> Richard E. Simpkin, Race to the Swift: Thoughts on Twenty-First Century Warfare (London, England: Brassey's Defence Publishers, 1985), p. 38.
- <sup>23</sup> Tukhachevskiy, p. 15, 47.  
and  
Deep Battle., p. 40.
- <sup>24</sup> Red Armour, p. 140.
- <sup>25</sup> Race to the Swift, p. 38.
- <sup>26</sup> Ibid., p. 16.
- <sup>27</sup> Jonathan M. House, Toward Combined Arms Warfare: A Survey of 20th Century Tactics, Doctrine, and Organization (Fort Leavenworth, KS: Combat Studies Institute, 1984), p. 49.
- <sup>28</sup> J.F.C. Fuller, Armored Warfare: Operations Between Mechanized Forces (Westport, CT: Greenwood Press, 1943), p. 7.
- <sup>29</sup> Ibid. p. 36.
- <sup>30</sup> Ibid., p. 70.
- <sup>31</sup> House, p. 46.
- <sup>32</sup> Heinz Guderian, Achtung-Panzer! The Development of Armored Forces, Their Tactics and Operational Potential, translated by Christopher Duffy (New York: Arms and Armour Press, 1937), pp. 178-181 and 188-198.
- <sup>33</sup> Ibid.
- <sup>34</sup> Turner, p. 154.

- <sup>35</sup> Race to the Swift, pp. 37-39.
- <sup>36</sup> Turner, pp. 204-217.
- <sup>37</sup> Ibid., pp. 205-206.
- <sup>38</sup> Ibid., pp. 199, 204-217, 219.
- <sup>39</sup> Giulio Douhet, "The Probable Aspects of the War of the Future," translated by Dino Ferrari, Command of the Air (Washington, D.C.: Office of Air Force History, 1963), pp. 143-208. Reprinted in The Evolution of Military Thought (Fort Leavenworth, KS: Combat Studies Institute, 1994), pp. 39-95.
- <sup>40</sup> Turner, p. 136.
- <sup>41</sup> Ibid., p. 142.
- <sup>42</sup> Ibid., p. 244.
- <sup>43</sup> Ibid., p. 201.
- <sup>44</sup> Tukhachevskiy, p. 47.
- <sup>45</sup> Fuller, p. 4.
- <sup>46</sup> Ibid.
- <sup>47</sup> Guderian, p. 207.
- <sup>48</sup> Howard A. Wheeler, Attack Helicopters (Baltimore, MD: The Nautical and Aviation Publishing Company of America, 1987), pp. 1-13.
- <sup>49</sup> Ibid., pp. 33-40.
- <sup>50</sup> Arthur T. Frame, "The 1st Cavalry Division's Exploitation of Helicopters in the Ia Drang Valley," Combined Arms in Battle Since 1939, Roger J. Spiller, ed. (Fort Leavenworth, KS: USACGSC Press, 1992), p. 11.
- <sup>51</sup> Ibid., p. 12.
- <sup>52</sup> Field Manual 100-2-3, The Soviet Army: Troops, Organization, and Equipment (Washington, D.C.: HQDA, 1991), pp. 4-116, 4-127, 4-128, 4-131, 4-139, 4-140.
- <sup>53</sup> Simpkin, Race to the Swift, p. 47; and Deep Battle, p. 249.

- <sup>54</sup> Race to the Swift, p. 117.
- <sup>55</sup> Richard Simpkin, Antitank: An Airmechanized Response to Armored Threats in the 90s (New York: Brassey's Publishers Limited, 1982), p. 236.
- <sup>56</sup> General Doctor von Senger und Etterlin. "The Air-Mobile Divisions" RUSI Journal, March 1987, p. 28.
- <sup>57</sup> Ibid.
- <sup>58</sup> John J. Tolson, Vietnam Studies: Airmobility 1961-1971 (Washington D.C.: Department of the Army, 1973), p. 120.
- <sup>59</sup> Antitank, p. 271.
- <sup>60</sup> Ibid., p. 272.
- <sup>61</sup> Ibid., p. 272-273.
- <sup>62</sup> Ibid., p. 272.
- <sup>63</sup> Ibid., p. 273.
- <sup>64</sup> Ibid., p. 272 and 275.
- <sup>65</sup> Ibid., p. 236.
- <sup>66</sup> Ibid.
- <sup>67</sup> General Doctor von Senger und Etterlin. "New Operational Dimensions." RUSI Journal, June 1983, p. 13.
- <sup>68</sup> Ibid., p. 14.
- <sup>69</sup> Ibid., p. 13.
- <sup>70</sup> Ibid.
- <sup>71</sup> Ibid., p. 12. Von Senger und Etterlin outlined several capabilities for his MBAV: a maximum speed of about 300 kilometers per hour; a range of about 600 kilometers; an ordinance payload of 4,000 pounds; a continuous hover capability; the capability to take off and land from unprepared surfaces; and a night/adverse weather operations capability.
- Rick Stockhausen, LONGBOW, COMANCHE, and the Aviation Restructure Initiative: Tactical Implications for the Heavy Division Attack Helicopter Battalion,

SAMS Monograph (Fort Leavenworth, KS: USACGSC, 1994), pp. 55-57 and 66-69. The AH-64 APACHE has a maximum speed of over 300 kilometers per hour; a basic range of 500 kilometers which can be extended to 700 kilometers with an auxiliary fuel tank; an ordinance payload of 4,090 pounds; a stabilized, continuous hover capability; the ability to operate from unprepared surfaces; and a night/adverse weather capability. The COMANCHE's capabilities will be even greater, to include longer flight endurance.

<sup>72</sup> Von Senger., pp. 12-15.

<sup>73</sup> Ibid.

<sup>74</sup> U.S. Army Combined Arms Combat Developments Activity, AirLand Battle Future: Alternate Case Study (Phase 1) (Fort Leavenworth, KS: CACDA, 1990), p. 22.

<sup>75</sup> Edward J. Sinclair, The Air Attack Division: AirLand Battle Future's Operational Contingency Force? SAMS Monograph (Fort Leavenworth, KS: USACGSC, 1990), pp. 19-20.

<sup>76</sup> TRADOC PAM 525-5, FORCE XXI Operations, p. 1-5.

<sup>77</sup> Ibid., p. 2-9.

<sup>78</sup> Ibid. p. 3-10.

<sup>79</sup> Ibid., p. 4-6.

<sup>80</sup> Student Test MSF-94PW, Operational Concepts for the Mobile Strike Force (Force XXI) (Fort Leavenworth, KS: USACGSC, 1994), p. 1-1.

<sup>81</sup> Ibid., p. 2-1.

<sup>82</sup> Force XXI Operations, p. 4-6.

and

U.S. Army Training and Doctrine Command, Force XXI Division Organizational and Operational Concept (Fort Monroe, VA: HQ, TRADOC, 1994), p. D-3.

<sup>83</sup> Aviation Restructure Initiative, p. 31. The ARI final objective version of the air assault division ARS contains 48 RAH-66 COMANCHE helicopters. This was considered still to small to provide adequate, continuous reconnaissance and surveillance for the ASF. The two smaller interim version ARS were deemed to have a sufficient number of aircraft and be more capable of distributed operations. Two objective version ARS were considered to be larger than required although equally capable. The interim ARS structures were selected in order to keep from over-inflating aircraft numbers.

<sup>84</sup> Bruce Reider, Exploiting Technology: Should the U.S. Army Employ the RAH-66 Comanche to Conduct SEAD Operations?, SAMS monograph (Fort Leavenworth, KS: USACGSC, 1994).

<sup>85</sup> Aviation Restructure Initiative, p. 27.

<sup>86</sup> Stockhausen, pp. 20-30.

<sup>87</sup> Aviation Restructure Initiative, p. 20.

<sup>88</sup> Deep Battle, p. 256.

<sup>89</sup> Field Manual 90-4, Air Assault Operations (Washington D.C.: HQDA, 1987), p. D-2.

and

Office of Army Systems Analysis, Weapon Systems: United States Army 1994 (Washington, D.C.: USGPO, 1994), p. 11. The UH-60L has an planning load of 9,000 pounds or 18 troops, and the CH-47D has a planning load of 20,000 pounds or 33 troops. Using an 80 percent operational readiness rate, 91 UH-60s and 76 CH-47s will be available to lift the ASF. Calculations assume that personnel requirements in addition to the 1300-man air assault task force will not exceed 300. A 1600-man troop requirement can be met with 20 CH-47s and 53 UH-60s. An additional 18 UH-60s will be required to move the artillery battalion (18 tubes). This leaves 20 UH-60s for command and control enhancement throughout the ASF. The remaining 56 CH-47s are capable of lifting 560 short tons of additional supplies and equipment.

<sup>90</sup> Command and General Staff College Student Text 101-5, Command and Staff Decision Processes (Fort Leavenworth, KS: USACGSC, 1994), pp. I-7-11 to I-7-13. While the tables in this student text are not meant to be exact, they do provide a rough estimate of relative combat power between various types of units. To avoid a possible over inflation of the combat power increases provided by the integration of the AH-64D LONGBOW and the RAH-66 COMANCHE, the comparison assumed equal relative increases in the combat power of each type of unit due to improvements in technology and organization. While this is simplistic, it does serve to keep estimates of the combat power of the ASF on the conservative side. The only change to the numbers in the student text were those of the ARS, which will greatly improve in combat power with both the OH-58D KIOWA WARRIOR and the RAH-66. It was given a combat power rating equivalent to that of an AH-64 battalion.

<sup>91</sup> Command and General Staff College Student Text 101-6, G1/G4 Battle Book (Fort Leavenworth, KS: USACGSC, 1994), p. 1-20.

<sup>92</sup> Command and General Staff College Student Text 100-3, Battle Book (Fort Leavenworth, KS: USACGSC, 1994), p. 4-7.

<sup>93</sup> G1/G4 Battle Book, pp. 1-10 to 1-12. This figure assumes good roads and weather conditions as well as no enemy interference.

<sup>94</sup> Cruise speed of 268 kph with an endurance of 1 hour and 45 minutes results in a range of 469 kilometers. This figure was reduced to 400 to account for time not spent at cruise (takeoff, landing, etc.).

<sup>95</sup> Battle Book, p. 4-7.

<sup>96</sup> G1/G4 Battle Book, pp. 1-10 to 1-14. These times assume planning for the moves have been completed. Moving at 200 kph, the ASF can cover the 400 kilometer distance in 2 hours. A heavy division moving on four routes at 32 kph requires 12.5 hours for the lead vehicles to reach the destination. As a minimum, pass time for the division will add an additional 5 hours and 12 minutes (moving with 20 vehicles per kilometer). This ignores additional time planning figures such as EXTAL, rest stops, and spacing between march units and serials. Limited to three air routes (a rather artificial restriction for the ASF due to its mobility) and serials of 10 aircraft, the ASF has a pass time of about an hour.

<sup>97</sup> Although risk of contamination exists, it is much less than that for ground vehicles.

<sup>98</sup> Race to the Swift, pp. 119-121. Simpkin goes into some depth in several of his works on the benefits of the helicopter's ability to use ground tactically without being tied to it for movement. One of the greatest advantages is the vast reduction in the pass time of a helicopter-mobile unit. This, in turn, increases the operational tempo of the formation.

<sup>99</sup> The ASF may raid into areas without adequate landing zones, but to perform operations that require endurance in a certain area it requires areas where it can rearm, refuel, and rest its helicopter crews.

<sup>100</sup> Battle Book, p. 4-6. Figures for the heavy division extracted from a major unit weapon system summary.

<sup>101</sup> This figure is based on an 80 percent operational readiness rate for both the AH-64D and the RAH-66; the AH-64D in an anti-armor configuration with 12 HELLFIRE missiles and an auxiliary fuel tank; the RAH-66 in a scout configuration with only 6 HELLFIRE missiles.  $HELLFIREs\ carried = (90 \times .8 \times 12) + (118 \times .8 \times 6) = 1428$ . Using a 75 percent probability of hit per missile, the ASF can expect to destroy up to 1071 vehicles with the armament mounted on its aircraft. Maximum armament loads for the AH-64D and the RAH-66 are 16 and 14, respectively.

<sup>102</sup> Information technology in the form of the 'digitized force' will be extremely important to the ASF in deep operational maneuver. It must be able to strike with precision not just to have a devastating effect upon the target, but to conserve supplies such as fuel and ammunition. The precise situational awareness envisioned in TRADOC

PAM 525-5 and other statements on FORCE XXI promise to provide the information and intelligence the ASF needs to achieve maximum efficiency in its operations. A critical component of the 'digitized force' will be responsive sensor-shooter links that provide near real-time targeting information to the force. The ASF will require direct links to operational-level sensors, such as JSTARS, in its deep maneuver.

<sup>103</sup> Soviet forces employed what was probably the most completely integrated air defense system in the world. The greatest threat to low flying aircraft was found at the tactical defensive front where the low-to-medium altitude air defense systems had their greatest concentrations. The further from the front, the more systems were designed to counter a fast-moving, high altitude air threat, leaving 'gaps' that could be exploited by rotary-wing aircraft.

<sup>104</sup> With an initial penetration of only 200 kilometers, the ASF retains the ability to conduct immediate combat operations for a limited period, if necessary, or to withdraw entirely. The ASF could penetrate as far as 400 kilometers, however, it would lack the fuel for an immediate withdrawal. While it would entail greater risk, the capability exists for the operational commander to exploit.

<sup>105</sup> This was done on a much smaller scale during Operation Desert Storm. APACHES from 1st Battalion, 101st Aviation Regiment, destroyed critical early warning radar sites, opening up a corridor for air component assets to exploit to strike deep against targets in Iraq.

<sup>106</sup> FM 100-5, p. 6-16. One of the most significant concerns for the operational commander is to defeat the enemy's operational reserves. The ASF may be given the mission to destroy these reserves or key portions of them depending on the situation.

<sup>107</sup> G1/G4 Battle Book, pp. 1-5 to 1-8. This figure was obtained by using the consumption figures for an air assault division as a base and adjusting from them to approximate the ASF. This included adding the fuel requirements for 3 AH-64 battalion equivalents and a CH-47 battalion, while subtracting 2 infantry brigades and an artillery battalion. Calculation: 292,277 (air assault division) + 54,534 (3 X ATKHB) + 122,880 (CH-47 battalion) - 10,000 (2 X infantry brigades) - 915 (105, T battalion) = 458,776 gallons per day.

<sup>108</sup> *Ibid.*, p. 1-5.

<sup>109</sup> This envisions most of the CH-47s unloading and returning to friendly territory for refuel. This reduces the ASF's forward force's requirement by 245,760 gallons per day. It also postures the CH-47s to conduct resupply of the ASF forward. These figures also assume a minimum of 10 percent fuel savings with split-based operations for the ASF as a whole. This reduces the amount of bulk fuel the ASF must push forward to 191,714--less than half of the overall requirement for the entire force.

<sup>110</sup> Ibid., pp. 1-6 to 1-8. This figure was obtained using the Class V planning requirements for day 1 of an attack and assuming that the ASF will operate in a moderate intensity battlefield environment (thus reducing overall requirements to 65 percent of heavy intensity). Calculation: 1450 STONS (air assault division) + 240 STONS (3 X ATKHB) 710 STONS (2 X infantry brigades) - 220 STONS (105, T battalion) = 760 STONS; 760 X .65=494 STONS per day. No reductions were taken for split basing because the bulk of the combat forces (using the bulk of this ammunition) are pushed forward.

<sup>111</sup> Fuel weight obtained by using the weight of JP-8, 6.8 pounds per gallon.  
Total STONS = 651.8 STONS (fuel) + 494 STONS (ammo) = 1145.8 STONS.

<sup>112</sup> Field Manual 55-9, Unit Air Movement Planning (Washington D.C.: HQDA, 1993), p. 2-1. For general airlift planning, the allowable cabin load for the C-130 is 25,000 pounds (1.25 STONS).

<sup>113</sup> Weapon Systems: United States Army 1994, p. 33. System can deliver 10.5 short tons gross weight. A C-130 could probably deliver two loaded with 10 short tons each.

<sup>114</sup> James Lucas, Battle Group! (London: Arms and Armour Press, 1993), pp. 7-9.

<sup>115</sup> Force XXI Operations, p. 4-5.

## Books

- Baxter, William. Soviet AirLand Battle Tactics. Novato, CA.: Presidio Press, 1986.
- Bellamy, Christopher. The Evolution of Modern Land Warfare. New York: Routledge, 1990.
- Bellamy, Christopher. The Future of Land Warfare. New York: St. Martin's Press, 1987.
- Fuller, J.F.C. Armored Warfare: Operations Between Mechanized Forces. Westport, CT: Greenwood Press, 1943.
- Fuller, J.F.C. On Future Warfare. London: Sifton Praed & Co., 1928.
- Galvin, John. Air Assault: The Development of Airmobile Warfare. New York: Hawthorne Books, 1969.
- Glantz, David. Soviet Military Operational Art: In Pursuit of Deep Battle. Portland, OR: Frank Cass, 1991.
- Glantz, David. The Soviet Airborne Experience. Fort Leavenworth, KS: Combat Studies Institute, 1985.
- Glantz, David. Deep Attack: The Soviet Conduct of Operational Maneuver. Fort Leavenworth, KS: Soviet Army Studies Office, 1987.
- Glantz, David. The Nature of Soviet Operational Art. Fort Leavenworth, KS: United States Army Combined Arms Center, as published in Parameters, Journal of the United States Army War College, Spring 1985.
- Guderian, Heinz. Achtung-Panzer! The Development of Armored forces, Their Tactics and Operational Potential. trans. by Christopher Duffy. New York: Arms and Armour Press, 1937.
- Holcomb, James F. and Turbeville, Graham H. Exploiting the Vertical Dimension: Continuing Development of Soviet Desant Force Structure. Fort Leavenworth, KS: Soviet Army Studies Office, 1987.
- House, Jonathan M. Toward Combined Arms Warfare: A Survey of 20th Century Tactics, Doctrine, and Organization. Fort Leavenworth, KS: Combat Studies Institute, 1984.
- Hussain, Farooq. The Future of the Military Helicopter. London: Royal United Services Institute, 1986.
- Kipp, Jacob W. Mass, Mobility, and the Russian Army's Road to Operational Art, 1918-1936. Fort Leavenworth, KS: United States Army Combined Arms Center, undated.

- Longworth, Philip. The Art of Victory. New York: Holt, Rinehart, and Winston, 1965.
- Savkin, V. Y. The Basic Principles of Operational Art and Tactics [1972]. Washington, D.C.: U.S. Government Printing Office, 1974.
- Simpkin, Richard. Antitank: An Airmechanized Response to Armored Threats in the '90s. Oxford: Brassey's, 1982.
- Simpkin, Richard. Red Armour: An Examination of the Soviet Mobile Force Concept. Oxford: Brassey's, 1984.
- Simpkin, Richard. Race to the Swift: Thoughts on Twenty-First Century Warfare. London: Brassey's, 1985.
- Simpkin, Richard. Deep Battle: The Brainchild of Marshall Tuchachevskii. London: Brassey's, 1987.
- Spiller, Roger J., ed. Combined Arms in Battle Since 1939. Fort Leavenworth, KS: USACGSC Press, 1992.
- Tukhachevskiy, Mikhail. "New Problems in Warfare." U.S. Army War College Art of War Colloquium: Soviet Operational concepts by Various Soviet Authors. Carlisle Barracks, PA: U.S. Army War College, 1983.
- Turner, Frederick C. The Genesis of the 'Deep Operation:' The Stalin-era Doctrine for Large-Scale Offensive Maneuver. Ann Arbor, MI: University Microfilms International, 1988.

#### Monographs

- Bolzack, Jerry R. The Role of the Airmechanized Raid in Operational Maneuver. Fort Leavenworth, KS: SAMS Monograph, AY 89-90.
- Burkhardt, Robert. The Corps Aviation Brigade and Operational Level Deep Battle: Organizational Considerations. Fort Leavenworth, KS: SAMS Monograph, AY 85-86.
- Chappell, Harold L. Evolution or Revolution: Mobility for the AirLand Battle-Future Concept. Fort Leavenworth, KS: SAMS Monograph, AY 90-91.
- Crawford, Darrel. Airmechanization: Determining Its Operational Viability on the AirLand Battlefield. Fort Leavenworth, KS: SAMS Monograph, AY 88-89.
- Crow, Charles. Tactical and Operational Depth. Fort Leavenworth, KS: SAMS Monograph, AY 85-86.

Drumm, Robert H. An American OMG? The Air Assault Division Employed as an Operational Maneuver Group. Fort Leavenworth, KS: SAMS Monograph, AY 91-92.

Inman, Michael T. Operational Maneuver in the 90's: Is Army Aviation a Viable Option? Fort Leavenworth, KS: SAMS Monograph, AY 89-90.

Jacobs, William M. Massing the Third Dimension in AirLand Battle-Future: The Aviation Division. Fort Leavenworth, KS: SAMS Monograph, AY 91-92.

Mosher, Alan M. Light Armor in Deep Operational Maneuver: The New Excalibur. Fort Leavenworth, KS: SAMS Monograph, AY 93-94.

Petrole, Gary P. Agility Versus Endurance in AirLand Battle-Future: A High-Risk Trade-Off. Fort Leavenworth, KS: SAMS Monograph, AY 90-91.

Pickar, Charles K. Blitzkrieg: Operational Art or Tactical Craft? Fort Leavenworth, KS: SAMS Monograph, AY 91-92.

Sinclair, Edward J. The Air Attack Division: AirLand Battle Future's Operational Contingency Force? Fort Leavenworth, KS: SAMS Monograph, AY 90-91.

Snodgrass, James. Operational Maneuver: From the American Civil War to the OMG. Fort Leavenworth, KS: SAMS Monograph, AY 87-88.

Webb, George S. Prescription for the Counterstroke: The Airmechanized Division at the Operational Level of War. Fort Leavenworth, KS: SAMS Monograph, AY 85-86.

#### Manuals

Field Manual 100-5, Operations. Washington, D.C.: Headquarters, Department of the Army, 1993.

Field Manual 1-100, Army Aviation in Combat Operations. Washington, D.C.: Headquarters, Department of the Army, 1989.

Field Manual 1-111, The Aviation Brigade. Washington, D.C.: Headquarters, Department of the Army, 1993.

Field Manual 100-15, Corps Operations. Washington, D.C.: Headquarters, Department of the Army, 1989.

Field Manual 71-100, Division Operations. Washington, D.C.: Headquarters, Department of the Army, 1990.

Field Manual 90-4, Air Assault Operations. Washington, D.C.: Headquarters, Department of the Army, 1987.

Field Manual 55-9, Unit Air Movement Planning. Washington, D.C.: Headquarters, Department of the Army, 1993.

#### Periodicals

Adams, John A. "Balancing Strategic Mobility and Tactical Capability," Military Review (August 1988), 16.

Brown, Frederic J. "AirLand Battle Future: The Other Side of the Coin," Military Review (February 1991), pp. 13-24.

Ostovich, Rudolph III. "Army Aviation in the AirLand Battle Future", Military Review (February 1991), p. 30-37.

Senger und Etterlin, F.M. von. "The Air-Mobile Divisions: Operational Reserves for NATO", RUSI Journal (1 March 1987), pp. 23-30.

Senger und Etterlin, F.M. von. "New Operational Dimensions", RUSI Journal (1 March 1987), pp. 23-30.

Simpkin, Richard E. "Airmechanized Forces for the 90's", Armor (July-August 1981), pp. 54-57.

#### Other

United States Army Aviation Center. Aviation Restructure Initiative: Foundation for the Future. Briefing booklet. Fort Rucker, AL: USAAVNC, February 1994.

Office of the Assistant Secretary of the Army. Weapon Systems: United States Army 1994. Washington, D.C.: Headquarters, Department of the Army, 1994.

United States Army Training and Doctrine Command Pamphlet 11-9, Blueprint of the Battlefield. Fort Monroe, VA: TRADOC, 10 May 1991.

United States Army Command and General Staff College Student Text 101-6, G1/G4 Battle Book. Fort Leavenworth, KS: USACGSC, 1994.

United States Army Command and General Staff College Student Text 100-3, Battle Book. Fort Leavenworth, KS: USACGSC, 1994.