

AEDC-TSR-95-P23



**A WIND TUNNEL TEST DEMONSTRATING THE
CAPABILITIES OF PRESSURE SENSITIVE PAINT**

**M. E. Sellers
Micro Craft Technology/AEDC Operations**

**November 1995
Final Report for Period April 25 - April 27, 1995**

Approved for public release; distribution is unlimited.

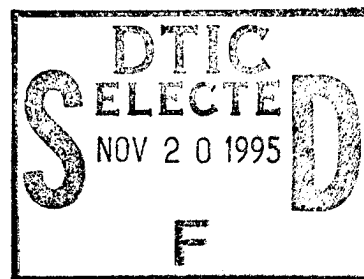

**ARNOLD ENGINEERING DEVELOPMENT CENTER
ARNOLD AIR FORCE BASE, TENNESSEE
AIR FORCE MATERIEL COMMAND
UNITED STATES AIR FORCE**

19951116 104

DTIC QUALITY INSPECTED 8

NOTICES

When U. S. Government drawings, specifications, or other data are used for any purpose other than a definitely related Government procurement operation, the Government thereby incurs no responsibility nor any obligation whatsoever, and the fact that the Government may have formulated, furnished, or in any way supplied the said drawings, specifications, or other data, is not to be regarded by implication or otherwise, or in any manner licensing the holder or any other person or corporation, or conveying any rights or permission to manufacture, use, or sell any patented invention that may in any way be related thereto.

Qualified users may obtain copies of this report from the Defense Technical Information Center.

References to named commercial products in this report are not to be considered in any sense as an endorsement of the product by the United States Air Force or the Government.

DESTRUCTION NOTICE

For unclassified, limited documents, destroy by any method that will prevent disclosure or reconstruction of the document.

APPROVAL STATEMENT

This report has been reviewed and approved.



THOMAS E. MANNING, 1Lt, USAF
Aircraft Systems Test Division
Test Operations Directorate

Approved for publication:

FOR THE COMMANDER



EUGENE J. SANDERS
Technical Director, Aircraft Sys Test Division
Test Operations Directorate

REPORT DOCUMENTATION PAGE			Form Approved OMB No. 0704-0188	
Public reporting burden for this collection of information is estimated to average 1 hour per response, including the time for reviewing instructions, searching existing data sources, gathering and maintaining the data needed, and completing and reviewing the collection of information. Send comments regarding this burden estimate or any other aspect of this collection of information, including suggestions for reducing this burden, to Washington Headquarters Services, Directorate for Information Operations and Reports, 1215 Jefferson Davis Highway, Suite 1204, Arlington, VA 22202-4302, and to the Office of Management and Budget, Paperwork Reduction Project (0704-0188), Washington, DC 20503.				
1. AGENCY USE ONLY (Leave blank)	2. REPORT DATE November 1995	3. REPORT TYPE AND DATES COVERED Final Report for April 25-27, 1995		
4. TITLE AND SUBTITLE A Wind Tunnel Test Demonstrating the Capabilities of Pressure Sensitive Paint			5. FUNDING NUMBERS PE - 65130D JN - 2171	
6. AUTHOR(S) M. E. Sellers Micro Craft Technology/AEDC Operations				
7. PERFORMING ORGANIZATION NAME(S) AND ADDRESS(ES) Arnold Engineering Development Center Air Force Materiel Command Arnold Air Force Base, TN 37389-6000			8. PERFORMING ORGANIZATION (REPORT NUMBER) AEDC-TSR-95-P23	
9. SPONSORING/MONITORING AGENCY NAME(S) AND ADDRESS(ES)			10. SPONSORING/MONITORING AGENCY REPORT NUMBER	
11. SUPPLEMENTARY NOTES Available in Defense Technical Information Center (DTIC).				
12A. DISTRIBUTION/AVAILABILITY STATEMENT Approved for public release; distribution is unlimited			12B. DISTRIBUTION CODE	
13. ABSTRACT (Maximum 200 words) A comparison of a pressure sensitive paint (PSP) developed at Arnold Engineering Development Center (AEDC) with a PSP developed in Russia was performed in the AEDC Propulsion Wind Tunnel 16T. A Generic Wall Interference Model, similar to an old AEDC model used to study wall interference effects, was fabricated at the Central Aerohydrodynamics Institute (TsAGI) in Zhukovsky, Russia. The model has been tested in the TsAGI T-128 wind tunnel and was sent to AEDC with the balance and sting support hardware for the 16T test. The AEDC PSP and Russian PSP were applied to separate wings of the model. Conventional pressure, PSP, and force data were acquired simultaneously at Mach numbers 0.60, 0.85, and 0.95 while angle of attack was varied from -10 to 10 deg. The stagnation pressure and temperature was also varied to permit evaluations of the pressure and temperature sensitivity of each paint. Following the PSP testing, the paint was removed and the model was configured to duplicate the configuration tested in T-128. Aerodynamic model loads and conventional pressure data were acquired at Mach numbers 0.60, 0.85, and 0.95 while angle of attack was varied from -10 to 10 deg. The Reynolds number was set to match the conditions obtained in T-128.				
14. SUBJECT TERMS Pressure Sensitive Paint wind tunnel test surface pressure distribution transonic Flow force and moment data			15. NUMBER OF PAGES 23	
			16. PRICE CODE	
17. SECURITY CLASSIFICATION OF REPORT UNCLASSIFIED	18. SECURITY CLASSIFICATION OF THIS PAGE UNCLASSIFIED	19. SECURITY CLASSIFICATION OF ABSTRACT UNCLASSIFIED	20. LIMITATION OF ABSTRACT UNCLASSIFIED	

COMPUTER GENERATED

Standard Form 298 (Rev. 2-89)
Prescribed by ANSI Std. Z3918
298-102

CONTENTS

	<u>Page</u>
NOMENCLATURE	2
1.0 INTRODUCTION	6
2.0 APPARATUS	7
2.1 Test Facility	7
2.2 Test Article	7
2.3 Test Instrumentation	8
3.0 TEST DESCRIPTION	8
3.1 Test Conditions and Procedures	8
3.2 Data Acquisition and Reduction	8
3.3 Adjustments	9
3.4 Uncertainty of Measurements	9
4.0 Data Presentation	9
REFERENCES	10

ILLUSTRATIONS

Figure

1. Model Installation	11
2. Model Details	12
3. Estimated Uncertainties in 16T Tunnel Parameters	13

TABLES

Table

1. Pressure Orifice Designation and Location	14
2. Nominal Test Conditions	15
3. Run Number Summary	16
4. Estimated Data Uncertainties	18

SAMPLE TABULATED DATA

Sample

1. Body Axis Coefficients	19
2. Stability Axis Coefficients and Pressures	20

Codes

Dist	Avail and / or Special
A-1	

NOMENCLATURE

AB	Model base area, 0.31472 ft ²
ACAV	Model cavity area, 0.094451 ft ²
AFA	Flow correction angle in pitch, deg
ALPHA	Model angle of attack, deg
ALPM	Model angle of attack from accelerometer, deg
BETA	Model sideslip angle, deg
B.L.	Model buttock line, in.
CA	Total axial-force coefficient, total axial force/(Q*SREF)
CAB	Base axial-force coefficient, [(P-PBA)AB]/(Q*SREF)
CACAV	Cavity axial-force coefficient, [(P-PCAVA)ACAV]/(Q*SREF)
CAF	Forebody axial-force coefficient, CA-CAB-CACAV
CDS	Total drag coefficient, stability axis, CA*cos(ALPHA) + CN*sin(ALPHA)
CDSF	Forebody drag coefficient, stability axis, CAF*cos(ALPHA) + CN*sin(ALPHA)
CLL	Rolling-moment coefficient, body axis, rolling moment/(Q*SREF*LREFL)
CLM	Pitching-moment coefficient, body axis, pitching moment/(Q*SREF*LREFM)
CLN	Yawing-moment coefficient, body axis, yawing moment/(Q*SREF*LREFN)
CLS	Total lift coefficient, stability axis, CN*cos(ALPHA) - CA*sin(ALPHA)

CLSF	Forebody lift coefficient, stability axis, $CN \cdot \cos(\text{ALPHA}) - CAF \cdot \sin(\text{ALPHA})$
CN	Normal-force coefficient, body axis, normal force/(Q*SREF)
CONFIG	Model configuration number, 1=AEDC PSP phase, 2=Russian PSP phase, 3=Force and pressure phase
CP _{ij}	Pressure coefficient, $(P_{ij} - P)/Q$, where i=F(fuselage), W(wing), H(horizontal), and j=1-25 (F), 1-24(W), 1-20(H)
CY	Side-force coefficient, body axis, side force/(Q*SREF)
DTDPS	Difference between test section static (T) and dewpoint temperatures, T-TDP, °F
F.S.	Model fuselage station, in.
H	Pressure altitude, ft
LM	Model length, 73.622 in.
LREFL	Model reference length for rolling-moment coefficients, 51.969 in.
LREFM	Model reference length for pitching-moment coefficients, 14.567 in.
LREFN	Model reference length for yawing-moment coefficients, 51.969 in.
M	Free-stream Mach number
MC	Plenum Mach number
MRC	Moment reference center
MODE	Data acquisition mode
P	Free-stream static pressure, psfa
PATM	Atmospheric pressure, psfa
PATMCL	Atmospheric pressure at the tunnel centerline, psfa
PBi	Base pressure, psfa, where i = 1 or 2

PBA	Average base pressure, psfa, $(PB1 + PB2)/2$
PC	Tunnel plenum chamber pressure, psfa
PCAVi	Cavity pressure, psfa, where $i = 1$ or 2
PCAVA	Average cavity pressure, psfa, $(PCAV1 + PCAV2)/2$
PHI	Model roll angle, deg
PROD DATE	Calendar date at which data were recorded
PT	Free-stream total pressure, psfa
PTINST	Stilling chamber total pressure, psfa
Q	Free-stream dynamic pressure, psf
RE	Free-stream unit Reynolds number, ft^{-1}
RUN	Data set identification number
RUN/SET	Run number that a constant set was loaded / the constant set number
SH	Wind tunnel specific humidity, lbm H ₂ O per lbm air
SREF	Model reference area, 5.2531 ft ²
STA	Tunnel station, ft
TEST	Test number designation
TDP	Tunnel dewpoint temperature, °F
TPR	Tunnel pressure ratio
TT	Free-stream total temperature, °F
T	Free-stream static temperature, °F
WA	Average test section wall angle positive value indicates that the walls are diverged, deg

WINDOFF	Run/point number of the air off set of instrument readings used in data reduction
W.L.	Model water line, in.
XCP/L	Normal-force center-of-pressure location, body axis, percent of body length, positive aft of nose, XMRC/LM - (CLM/CN)*(LREFM/LM)
XMRC	Distance from nose to moment reference point, in.
XT	Transfer distance from balance electrical center to model nose, 8.032 in.

1.0 INTRODUCTION

The work reported herein was conducted by the Arnold Engineering Development Center (AEDC), Air Force Materiel Command (AFMC), under Program Element 65139D, at the request of AEDC/DOT, Arnold AFB, TN 37389-6000. The AEDC project manager was Capt. Jay Cossentine. The results of the test were obtained by Micro Craft Technology/AEDC Operations, support contractor for aerodynamic testing at AEDC, AFMC, Arnold Air Force Base, TN. The test was performed in the AEDC Propulsion Wind Tunnel (PWT) 16T during the period of April 25-27, 1995, under AEDC Job Number 2171, PWT Test Number TF-897.

The objectives of the test were to conduct a comparative evaluation of pressure sensitive paints developed at AEDC and by OPTROD Ltd. in Zhukovsky, Russia, and to evaluate the performance of adaptive wall technology used in the Central Aerohydrodynamics Institute (TsAGI) wind tunnel T-128. A larger scale version of a model tested at AEDC in the late 70s to investigate adaptive wall techniques for removing wind tunnel wall interference effects from model data was designed and fabricated at TsAGI and was used for the test in 16T. The model had previously been tested in T-128 in November, 1994 at several fixed, uniform wall porosities and with distributed wall porosity set to reduce wall interference.

Pressure sensitive paint (PSP) is a surface coating whose luminosity varies with local surface pressure when excited by light of an appropriate wavelength. The major advantages of using PSP are to provide a complete surface pressure distribution and to obtain information in areas where it is not possible to install pressure orifices. Unfortunately, the paints currently available also respond to changes in surface temperature, to varying magnitudes, which affect the accuracy of pressure determination. To make PSP a viable alternative to replacing conventional pressure instrumentation the paint temperature sensitivity must be reduced or eliminated, or a way of simultaneously measuring the global surface temperature must be found. The AEDC PSP is very sensitive to changes in temperature while the OPTROD PSP (designated L2) has a low sensitivity to temperature. Each paint was applied to separate wings of the model and tested at the same tunnel conditions to permit evaluation of the pressure and temperature sensitivity. Aerodynamic model loads, conventional surface pressure, and pressure sensitive paint image data were acquired at Mach numbers 0.60, 0.85, and 0.95 while angle of attack was varied from -10 to 10 deg. The stagnation pressure and temperature were also varied at 0.85 Mach number.

Following the PSP testing, the paint was removed and the model was configured to duplicate the configuration tested in T-128. Aerodynamic model loads and conventional surface pressure data were acquired at Mach numbers 0.60, 0.85, and 0.95 while angle of attack was varied from -10 to 10 deg. The Reynolds number was set to match the conditions obtained in T-128. The data acquired in 16T will be used as the interference-free case for comparison with the adaptive wall data acquired in T-128.

The information herein is provided expressly to document the test, describe the test parameters, and facilitate subsequent data analysis. The final data package is on file at AEDC on microfiche and any requests for the data should be addressed to AEDC/DOT, Arnold AFB, TN, 37389.

2.0 APPARATUS

2.1 TEST FACILITY

The AEDC Propulsion Wind Tunnel (16T) is a closed-loop continuous flow, variable-density tunnel with a Mach number capability of 0.06 to 1.60 and stagnation pressure from 120 to 4,000 psfa. The maximum attainable Mach number can vary slightly depending upon the tunnel pressure ratio requirements with a particular test installation. The maximum stagnation pressure attainable is a function of Mach number and available electric power. The tunnel stagnation temperature can be varied from approximately 80 to 160°F depending upon the cooling water temperature. The tunnel is equipped with a scavenging system which removes combustion products when testing rocket motors or turbo-engines.

The test cart used was the High Angle Automated Sting (HAAS) cart which has a 16-ft square by 40-ft long test section enclosed by porous walls. The wall porosity is fixed at six-percent and is provided by regularly-spaced 1-in.-diam holes which are inclined upstream at a 60-deg angle. The test section is completely enclosed in a plenum chamber from which air is evacuated at transonic and supersonic conditions, thus removing part of the tunnel airflow boundary layer through the porous walls of the test section. The HAAS test section has a side wall angle variation capability from -2.0 (convergence) to 0.8 deg (divergence). To compensate for the HAAS strut blockage, each side wall has a bulge section 6.0 in. deep. The model support system consists of a sector and sting attachment which has a pitch capability of -18.6 to 28 deg, in position 1, with respect to the tunnel centerline, and a roll capability of ± 180 deg about the sting centerline.

2.2 TEST ARTICLE

Test section details and the installation of the test article in 16T are shown in Fig. 1. The generic wall interference model (GWIM) model has a cylindrical body diameter of 8.661 in. with an elliptical nose. The wing and horizontal tail are symmetrical NACA 0012 airfoils with 30-deg swept-back leading and trailing edges. The model has a span of 51.964 in. and is 73.622 in. long. Details of the model are given in Fig. 2. The fuselage, wing, and horizontal tail each have one row of pressure orifices. The pressure orifice designations and locations are listed in Table 1. In the first phase of the test the top surface of the starboard wing (with pressure orifices) was painted with the AEDC PSP and the bottom surface of the port wing was painted with the L2 PSP.

For the second phase, the paint was removed and laminar to turbulent boundary-layer transition trips were applied to permit acquisition of data for comparison with T-128 data.

Boundary-layer transition strips, consisting of Epoxy[®] discs, were applied to the model nose and wing and horizontal tail leading edges. Discs 0.05 in. diam and 0.005 in. high were located on 0.10-in. centers 1.5 in. aft of the nose and on the wing and horizontal tail surfaces 1.5 in. aft of the leading edge as was done in T-128. The trip height and location were determined by AEDC personnel to provide turbulent flow at all Mach numbers and atmospheric total pressure. The boundary-layer transition trips were not applied to the wings when the PSP was present.

2.3 INSTRUMENTATION

The model aerodynamic forces and moments were measured using an internally mounted, six-component strain-gage balance (fabricated at TsAGI). The surface pressures were measured using two 48-port electronically scanned pressure (ESP) modules referenced to atmosphere and mounted inside the model. Each port had a silicon pressure transducer that was digitally addressed and calibrated online. The data quality of the ESP module was monitored by applying and measuring a known pressure on several unused ports of the module. An accelerometer (developed by TsAGI) was mounted inside the model to provide a secondary measurement of the model pitch attitude.

3.0 TEST DESCRIPTION

3.1 TEST CONDITIONS AND PROCEDURES

Measurements of the steady-state forces, moments, and pressures, and paint images (when present) were obtained at Mach numbers from 0.6 to 0.95. The nominal test conditions established during the test are given in Table 2. Tunnel conditions were held constant while varying model attitude. Data were recorded at selected angles using the pitch-pause technique. Data were obtained at angles of attack from -10 to 10 deg. A test run number summary is presented in Table 3.

3.2 DATA ACQUISITION AND REDUCTION

All steady-state measurements were sequentially recorded by the facility computer system and reduced to the final form. The data were then tabulated in the Tunnel 16T control room, recorded on magnetic tape, and transmitted to the Analysis and Display System (ADS). The data stored on the ADS were generally available for plotting and analysis immediately after completion of the polar. The availability of the tabulated and plotted data permitted continual online monitoring of the test results. The PSP images were acquired by a personal computer under control of the facility computer and processed on a UNIX workstation. A complete description of the data

acquisition and reduction of the PSP data is reported in a Technical Report yet to be published.

The model force and moment data were reduced to coefficient form in the body and stability axis systems. The reference area and lengths used in the data reduction are given in the Nomenclature. The moment reference point is shown in Fig. 2. The average cavity pressure and its area (given in Nomenclature) were used to calculate the cavity axial force. The average base pressure and its area (given in Nomenclature) were used to calculate the base axial force. The base and cavity axial forces were subtracted from the balance measured axial force to permit calculation of the forebody coefficients. The model surface pressures were reduced to coefficient form using the tunnel free-stream static and dynamic pressure.

3.3 ADJUSTMENTS

The flow angularity in the tunnel pitch plane (AFA), see Table 2, was determined at each Mach number by testing the model upright and inverted over a small angle-of-attack range. The sector pitch angle was adjusted for sting deflections in the pitch plane, caused by aerodynamic loads, and for AFA when setting the model angle of attack (ALPHA). Adjustments for the components of model weight, normally termed static tares, were also accounted for before the measured loads were reduced to coefficient form.

3.4 UNCERTAINTY OF MEASUREMENTS

Uncertainties (combinations of system and random errors) of the basic tunnel parameters, shown in Fig. 3, were estimated from repeat calibrations of the instrumentation and from repeatability and uniformity of the test section flow during tunnel calibration. Uncertainties in the instrumentation systems were estimated from repeat calibration of the systems using secondary standards having uncertainties which are traceable to the National Institute of Standards and Technology (formerly National Bureau of Standards) calibrated equipment. Because the balance calibration was transferred from TsAGI and the calibration data were not made available to AEDC, the balance uncertainty was assumed to be 0.25% of the balance limits. These uncertainties were combined with the tunnel parameters and instrument uncertainties, as described in Ref. 1, to determine the uncertainties of the parameters presented in Table 4. A method for determining the uncertainty of the PSP data has not been produced at this time.

4.0 DATA PRESENTATION

Tabulated data summaries listing specific parameters were generated as well as digital files containing all of the parameters of the test data. Digital images and photographs of the PSP data were generated. Samples of the tabulated data are presented in Samples 1 and 2.

REFERENCES

1. Sellers, M.E. "A Comparison of an AEDC and a Russian Developed Pressure Sensitive Paint in the AEDC Propulsion Wind Tunnel 16T." AEDC-TR-95-18, December 1995.
2. Abernethy, R.B. and Thompson, J.W., Jr. "Handbook - Uncertainty in Gas Turbine Measurements." AEDC-TR-73-5 (AD755356), February 1973.

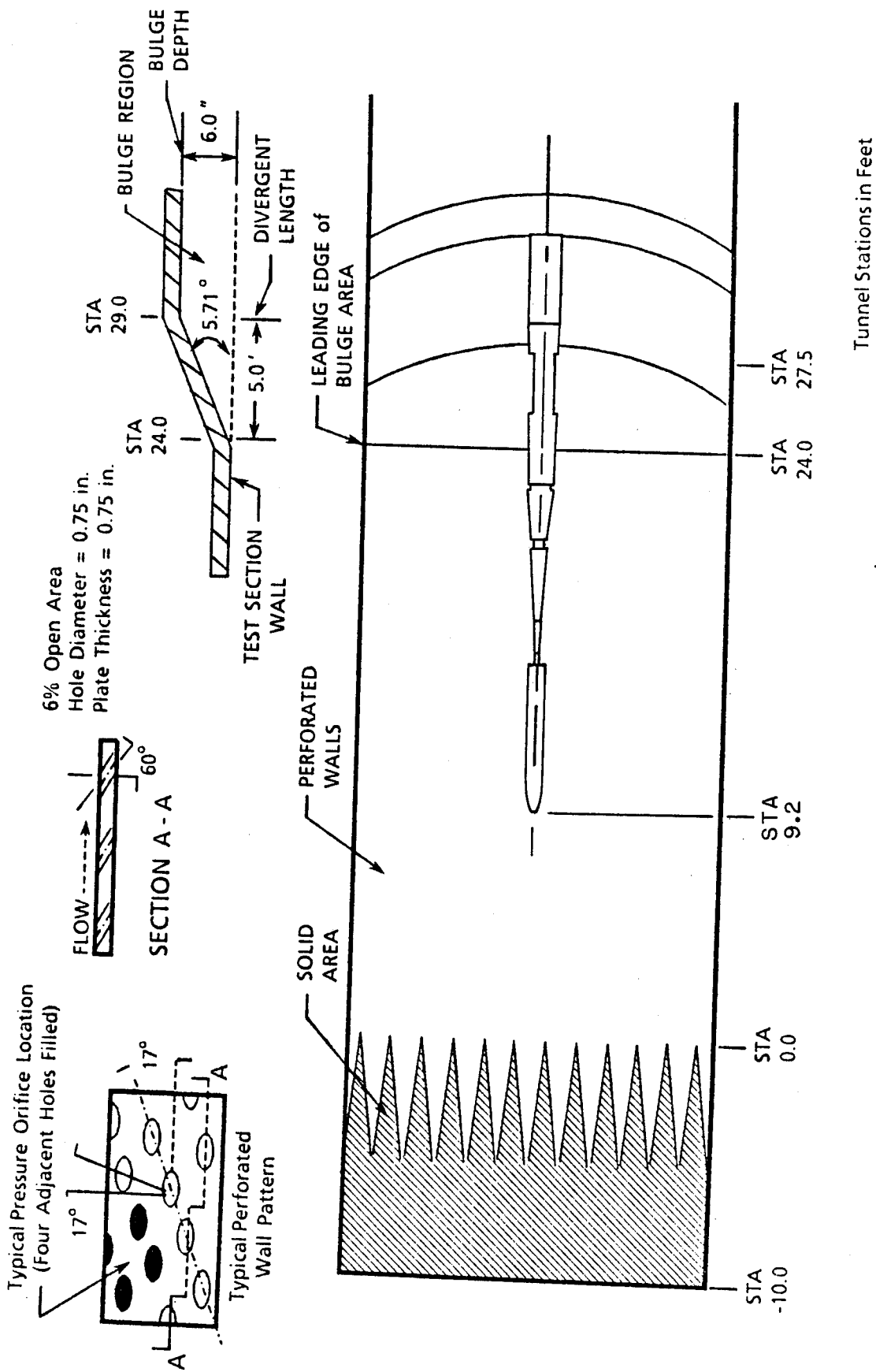

Figure 1. Model Installation

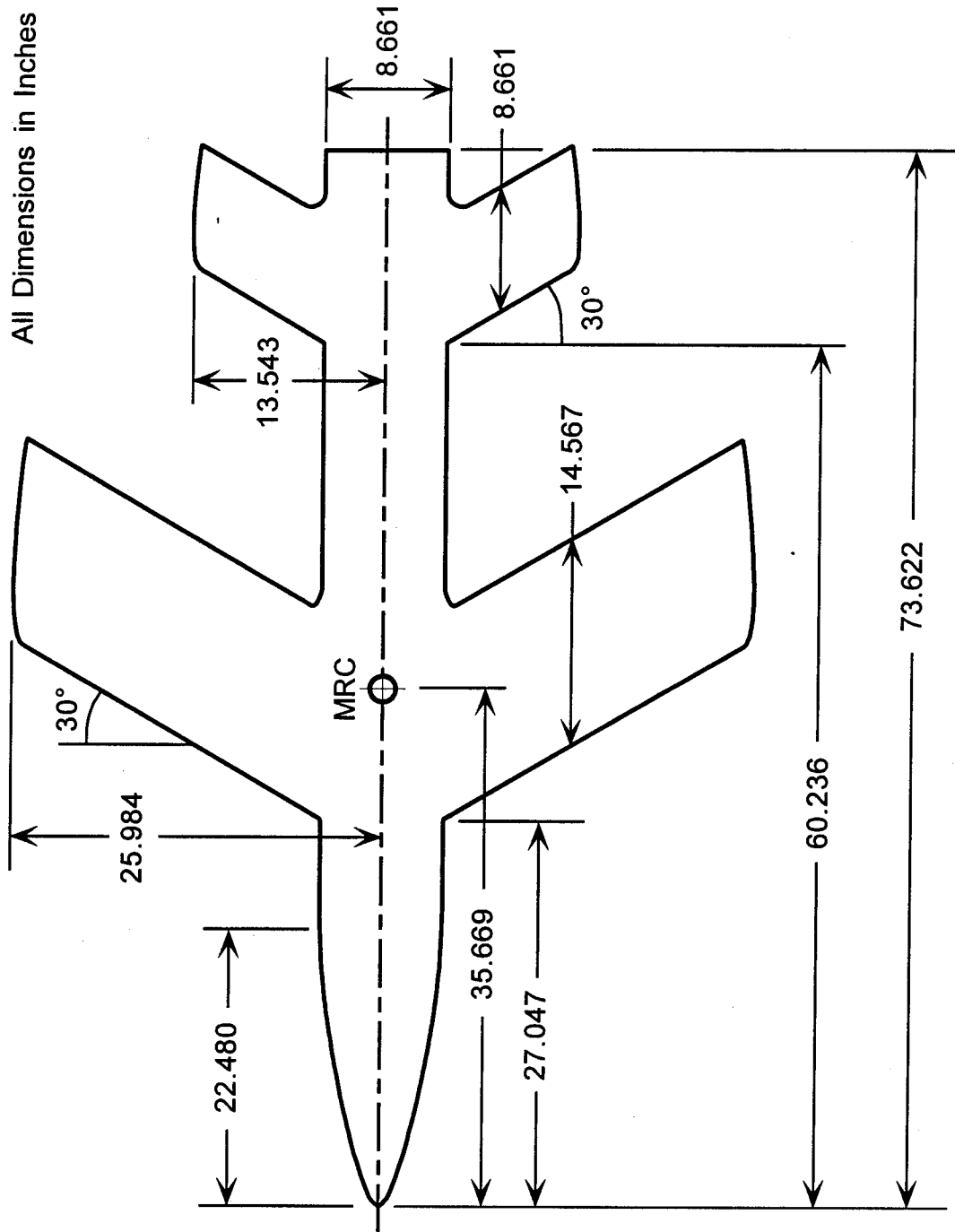

Figure 2. Model Details

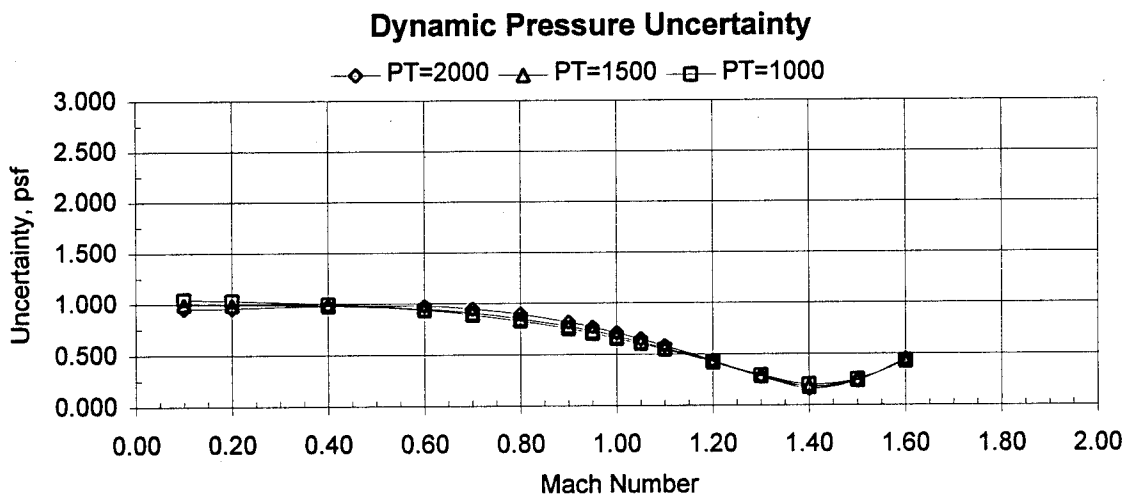
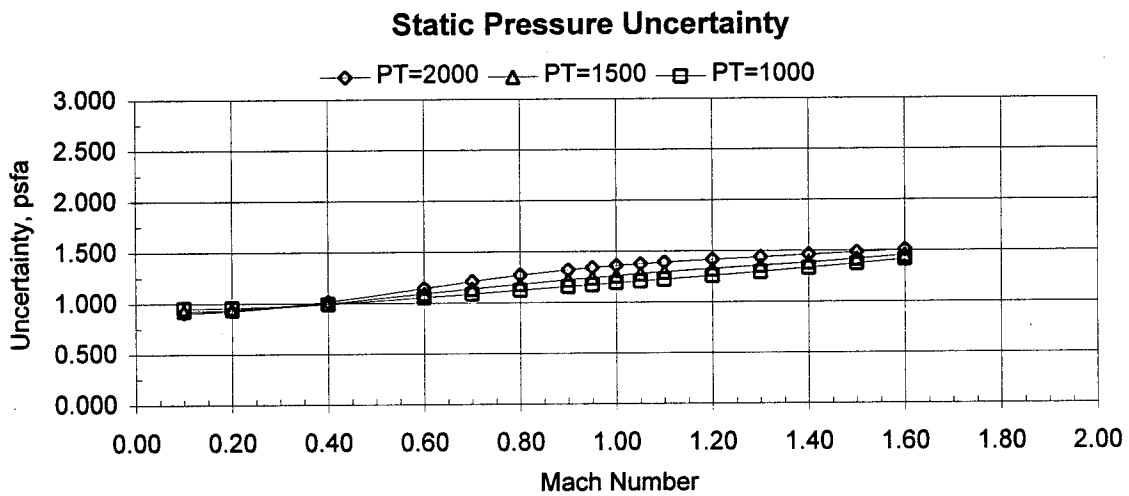
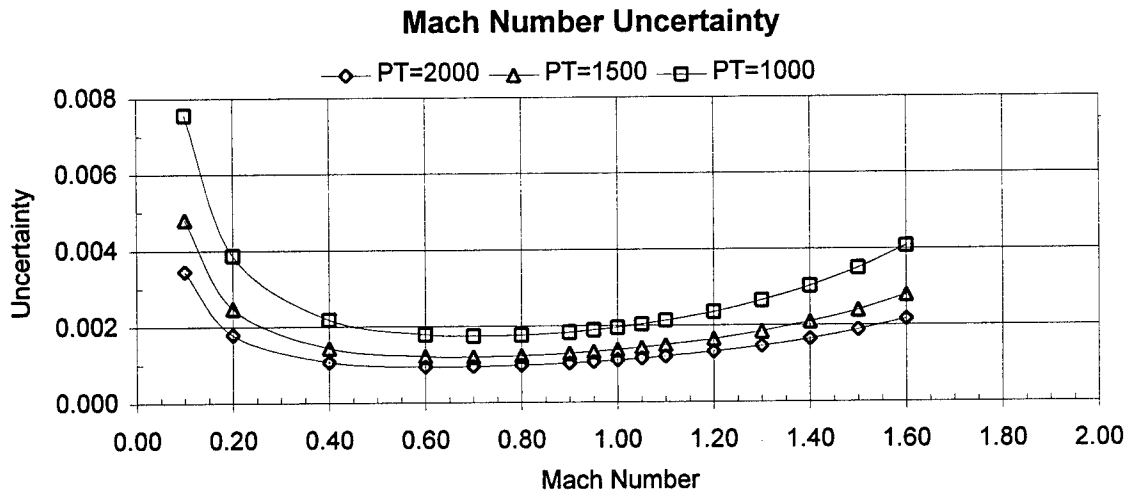

Figure 3. Estimated Uncertainties in 16T Tunnel Parameters

Table 1. Pressure Orifice Designation and Location

Location	No.	F.S.	B.L.	W.L.
Fuselage	1	2.168	0.000	1.215
	2	4.332	0.000	1.864
	3	6.496	0.000	2.391
	4	8.661	0.000	2.866
	5	10.828	0.000	3.287
	6	12.991	0.000	3.636
	7	15.157	0.000	3.906
	8	17.322	0.000	4.122
	9	19.486	0.000	4.214
	10	21.650	0.000	4.275
	11	23.815	0.000	4.330
	12	25.975	0.000	4.330
	13	28.162	0.000	4.330
	14	30.326	0.000	4.330
	15	32.492	0.000	4.330
	16	34.655	0.000	4.330
	17	36.821	0.000	4.330
	18	38.988	0.000	4.330
	19	41.153	0.000	4.330
	20	43.319	0.000	4.330
	21	45.484	0.000	4.330
	22	47.644	0.000	4.330
	23	49.812	0.000	4.330
	24	51.974	0.000	4.330
∇	25	54.143	0.000	4.330
Wing	1	47.313	16.460	0.187
	2	46.520	16.425	0.279
	3	45.823	16.439	0.366
	4	45.080	16.445	0.446
	5	44.364	16.439	0.521
	6	43.632	16.450	0.590
	7	42.859	16.438	0.652
	8	42.154	16.432	0.709
	9	41.430	16.452	0.760
∇	10	40.685	16.470	0.802

Location	No.	F.S.	B.L.	W.L.
Wing	11	39.960	16.481	0.834
	12	39.213	16.478	0.856
	13	38.486	16.480	0.864
	14	37.744	16.489	0.855
	15	37.004	16.496	0.826
	16	36.277	16.478	0.769
	17	35.533	16.447	0.674
	18	35.174	16.476	0.608
	19	34.644	16.444	0.470
	20	34.337	16.444	0.335
	21	37.028	16.367	-0.826
	22	39.947	16.385	-0.834
	23	41.387	16.348	-0.760
	24	42.862	16.335	-0.652
∇	25	45.754	16.336	-0.366
Tail	1	71.217	9.947	0.081
	2	70.434	9.952	0.180
	3	69.993	9.958	0.221
	4	69.558	9.962	0.260
	5	69.115	9.964	0.298
	6	68.676	9.954	0.345
	7	68.250	9.956	0.381
	8	67.823	9.967	0.405
	9	67.381	9.970	0.437
	10	66.947	9.967	0.456
	11	66.489	9.960	0.469
	12	66.082	9.977	0.474
	13	65.190	9.973	0.448
	14	64.329	9.968	0.366
	15	63.630	9.945	0.174
	16	65.188	9.947	-0.488
	17	66.932	9.955	-0.489
	18	67.809	9.953	-0.446
	19	68.683	9.959	-0.389
∇	20	70.403	9.949	-0.225

**Table 2. Nominal Test Conditions
a. Pressure Sensitive Paint Phase**

M	PT, psfa	P, psfa	Q, psf	TT, °F	T, °F	REx10 ⁻⁶	AFA
0.60	1,000	784	198	90	54	1.60	-0.20
0.85	1,000	624	315	90	32	1.96	-0.15
0.85	1,000	624	315	120	48	1.83	-0.15
0.85	2,000	1,247	631	90	22	3.92	-0.15
0.85	2,000	1,247	631	120	48	3.66	-0.15
0.95	1,000	560	353	90	7	2.05	-0.15

b. Force and Pressure Phase

M	PT, psfa	P, psfa	Q, psf	TT, °F	T, °F	REx10 ⁻⁶	AFA
0.60	2,530	1,983	501	96	58	4.00	-0.34
0.847	1,807	1,131	567	96	26	3.49	-0.19
0.946	1,261	709	444	95	11	2.55	-0.17

Table 3. Run Number Summary

PT	TT	REX10-6	ALPHA	PHI	Mach Number								Remarks	
					0.175	0.3	0.6	0.847	0.85	0.946	0.95			
1000	90	1.6	Var	0/180			178/179							Flow Angle
		1.6	Var	0			181/182							AEDC PSP Data
		1.96	Var	0/180				184/185						Flow Angle
		1.96	Var	0				187						AEDC PSP Data
		2.05	Var	0/180								190/191		Flow Angle
		2.05	Var	0								193-196		AEDC PSP Data
	✓	2.05	Var	0								199		
2000	95	3.92	Var	0				257-259						
		3.66	Var	0				260						Exp=0.6 sec
		3.66	Var	0				261						Exp=0.9 sec
		3.66	6	0				262						Exp=0.5 sec
		3.66	6	0				263						Exp=0.4 sec
		3.66	6	0				264						Exp=0.3 sec
	✓	3.66	6	0				265						Exp=0.2 sec
		3.66	6	0				266						Exp=0.1 sec
1000	120	1.83	Var	0				269-270						
1000	95	1.6	Var	180			285							Russian PSP Data
1000		1.96	Var	180				290						
1000		2.05	Var	180								291		
2000		3.92	Var	180				292						
2000	✓	3.92	6	180				293						Exp=0.8 sec

Table 3. Concluded

PT	TT	REX10-6	ALPHA	PHI	Mach Number							Remarks
					0.175	0.3	0.6	0.847	0.85	0.946	0.95	
2000	95	3.92	6	180					294			Russian PSP Data Exp=0.7 sec
		3.92	6	180					295			Exp=0.6 sec
		3.92	6	180					296			Exp=0.5 sec
		3.92	6	180					297			Exp=0.4 sec
	✓	3.92	6	180					298			Exp=0.3 sec
✓	116	3.66	Var	180					299-300			
1000	116	1.83	Var	180					301			
2000	95	1.78	Var	180	306	303						✓
												Force & Pressure Phase
2540	95	4.02	Var	0/180			323/324					Flow Angle
2540		4.02	Var	0			325					
2540		4.02	Var	0			326					Repeat
1807		3.5	Var	0/180				328/329				Flow Angle
1807		3.5	Var	0				330				High Humidity (Wet)
1807		3.5	Var	0				331				Repeat
1807		3.5	Var	0				332				Low Humidity (Dry)
1807		3.5	Var	0				333				Repeat
1261		2.55	Var	0/180						335/336		Flow Angle
1261		2.55	Var	0						337		
1261	✓	2.55	Var	0						338		Repeat

ALPHA was varied from -10 to 10 in 2 deg increments except for 0/180 runs which were -4 to 4 in 2 deg increments
 Additional points were acquired during the Force & Pressure phase at attitudes to match T-128 data points

Table 4. Estimated Data Uncertainties

Parameter	Mach Number						
	0.6	0.6	0.85	0.85	0.85	0.95	0.95
PT	1000	2530	1000	1807	2000	1000	1261
CN	0.020	0.0084	0.013	0.0073	0.0067	0.011	0.0091
CLM	0.013	0.0052	0.0083	0.0046	0.0042	0.0074	0.0059
CY	0.0024	0.0009	0.0015	0.0008	0.0008	0.0013	0.0011
CLN	0.0010	0.0004	0.0006	0.0003	0.0003	0.0005	0.0004
CLL	0.0008	0.0003	0.0005	0.0003	0.0003	0.0004	0.0004
CA	0.0049	0.0021	0.0030	0.0017	0.0015	0.0027	0.0021
CAF	0.0049	0.0021	0.0030	0.0017	0.0015	0.0027	0.0021
CAB	0.0022	0.0014	0.0013	0.0004	0.0005	0.0006	0.0004
CLS	0.020	0.0083	0.013	0.0072	0.0066	0.011	0.0090
CDS	0.0061	0.0026	0.0038	0.0022	0.0020	0.0034	0.0027
CLSF	0.020	0.0083	0.013	0.0072	0.0066	0.011	0.0090
CDSF	0.0061	0.0026	0.0038	0.0022	0.0020	0.0034	0.0027
PBi	1.84	1.84	1.84	1.84	1.84	1.84	1.84
PCAVi	1.84	1.84	1.84	1.84	1.84	1.84	1.84

DATE 1-JUN-95
 MICRO CRAFT TECHNOLOGY
 AEDC OPERATIONS
 PROPULSION WIND TUNNEL
 ARNOLD AIR FORCE BASE, TENNESSEE

RUN 182
 TEST TF-897
 M 0.600 PT 999.8 P 783.8 Q 197.6 REX10-6 TT 91.3 H 25046.
 PC 789.4 MC 0.5910 WA 0.00 TPR 1.092 SHX10+3 TDP 23.9
 PROD DATE 1-JUN-95 WINDOFF 176/ 2 RUN/ SET 178/ 72
 MODE 10/10 TRANSONIC 16T
 DTDPS 35.5 PATM 2039.5 PATMCL 2038.9 PTINST 999.9
 SUMMARY PAGE NO. 1

PN	ALPHA	BETA	PHI	CN	CLM	CLN	CLL	CAF	CAB	CACAV	CABC
1	0.00	-0.01	0.0	0.0013	-0.0032	0.0002	0.0008	0.0155	0.0064	0.0019	0.0084
2	-1.97	-0.01	0.0	-0.1386	-0.0051	0.0002	0.0005	0.0140	0.0064	0.0018	0.0083
3	-3.98	-0.01	0.0	-0.2815	0.0007	0.0003	0.0002	0.0068	0.0066	0.0020	0.0085
4	-5.97	-0.01	0.0	-0.4223	0.0056	0.0003	-0.0002	0.0058	0.0068	0.0021	0.0089
5	-7.97	-0.01	0.0	-0.5680	0.0097	0.0003	-0.0003	-0.0234	0.0071	0.0021	0.0092
6	-9.98	-0.01	0.0	-0.7103	0.0135	0.0002	-0.0005	-0.0383	0.0078	0.0022	0.0100
7	-0.04	-0.01	0.0	-0.0035	-0.0020	0.0003	0.0007	0.0164	0.0065	0.0019	0.0084
8	1.96	-0.01	0.0	0.1348	0.0009	0.0003	0.0010	0.0132	0.0066	0.0019	0.0085
9	3.96	-0.01	0.0	0.2764	-0.0047	0.0002	0.0013	0.0046	0.0069	0.0020	0.0089
10	5.96	-0.01	0.0	0.4224	-0.0101	0.0002	0.0016	-0.0091	0.0070	0.0020	0.0090
11	7.97	-0.01	0.0	0.5657	-0.0137	0.0001	0.0017	-0.0276	0.0073	0.0021	0.0094
12	9.97	-0.01	0.0	0.7001	-0.0157	0.0000	0.0012	-0.0429	0.0077	0.0022	0.0099

Sample 1. Body Axis Coefficients

DATE 1-JUN-95
 MICRO CRAFT TECHNOLOGY
 AEDC OPERATIONS
 PROPULSION WIND TUNNEL
 ARNOLD AIR FORCE BASE, TENNESSEE

RUN 182 TEST TF-897
 MODE 10/10
 PROD DATE 1-JUN-95 WINDOFF 176/ 2 RUN/ SET 178/ 72
 TRANSONIC 16T
 M PT P Q REX10-6 TT H
 0.600 999.8 783.8 197.6 1.596 91.3 25046.
 PC 789.4 MC 0.5910 WA 0.00 TPR 1.092 SHX10+3 TDP 23.9 DTDPS 35.5 PATM 2039.5 PATMCL PTINST 2038.9 999.9

SUMMARY PAGE NO. 2

CONFIG 1 SREF 5.2531 LREFM 14.567 LREFN 51.969 LREFL 51.969 LM 73.622

PN	ALPHA	BETA	PHI	STABILITY AXIS COEFFICIENTS AND PRESSURES											
				ALPM	CLS	CDS	CLSF	CDSF	XPC/L	PB1	PB2	PCAV1	PCAV2		
1	0.00	-0.01	0.00	0.20	0.0013	0.0239	0.0013	0.0155	0.9606	762.	763.	762.	763.	762.	763.
2	-1.97	-0.01	0.00	-1.78	-0.1377	0.0270	-0.1380	0.0188	0.4773	763.	763.	764.	764.	764.	764.
3	-3.98	-0.01	0.00	-5.78	-0.2797	0.0348	-0.2803	0.0283	0.4850	762.	763.	762.	763.	762.	763.
4	-5.97	-0.01	0.00	-7.77	-0.4196	0.0470	-0.4206	0.0382	0.4871	762.	762.	762.	762.	762.	761.
5	-7.97	-0.01	0.00	-9.80	-0.5645	0.0647	-0.5658	0.0556	0.4879	760.	760.	761.	761.	761.	761.
6	-9.98	-0.01	0.00	-9.80	-0.7044	0.0953	-0.7062	0.0654	0.4882	757.	758.	760.	760.	760.	758.
7	-0.04	-0.01	0.00	0.13	-0.0035	0.0249	-0.0035	0.0164	0.3694	762.	762.	762.	762.	762.	763.
8	1.96	-0.01	0.00	2.15	0.1340	0.0263	0.1343	0.0178	0.4831	762.	762.	763.	763.	763.	763.
9	3.96	-0.01	0.00	4.15	0.2748	0.0326	0.2754	0.0237	0.4879	761.	761.	761.	761.	761.	762.
10	5.96	-0.01	0.00	6.16	0.4201	0.0437	0.4211	0.0348	0.4892	761.	761.	762.	762.	762.	763.
11	7.97	-0.01	0.00	8.18	0.5627	0.0604	0.5640	0.0511	0.4893	760.	761.	761.	761.	761.	761.
12	9.97	-0.01	0.00	10.16	0.6953	0.0886	0.6970	0.0789	0.4889	759.	759.	761.	761.	761.	760.

Sample 2. Stability Axis Coefficients and Pressures