

NASA Contractor Report 177936

*Index*  
*attf*

# EVALUATION OF HIGH TEMPERATURE STRUCTURAL ADHESIVES FOR EXTENDED SERVICE - PHASE IV

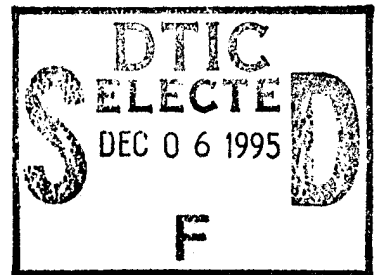

C. L. Hendricks, S. G. Hill and J. N. Hale

Boeing Aerospace Company  
Seattle, Washington 98124

Contract NAS1-15605  
October 1985

19951121 096

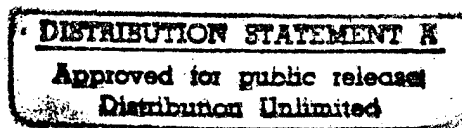

# NASA

National Aeronautics and  
Space Administration

Langley Research Center  
Hampton, Virginia 23665

DTIC QUALITY INSPECTED 6

PLASTED  
1995/11/21

## FOREWORD

This report describes the program performed by the Boeing Aerospace Company for the National Aeronautics and Space Administration, Langley Research Center, under Contract NAS1-15605 - Phase IV. This work was conducted during the period October 15, 1983 to October 15, 1985. Use of commercial products or names in this report does not constitute official endorsement of such products or manufacturer, either expressed or implied, by the National Aeronautics and Space Administration.

Future aerospace vehicles are being designed for performance requirements that impose stringent demands upon structural materials. Adhesive bonding of metallic and composite structures offers the potential to significantly improve structural efficiency and reduce manufacturing costs. This program was dedicated to the test and evaluation of promising adhesive resins produced by NASA (Langley Research Center), King Mar Laboratories, and Hunt Chemical Corporation.

Mr. P. Hergenrother was the NASA Technical Monitor. The Materials and Processes Technology organization of the Boeing Aerospace Company was responsible for the work performed in this program. Mr. C. L. Hendricks was Program Manager and Mr. S. G. Hill was Technical Leader. The following personnel provided critical support to various program activities.

<p>J. N. Hale O. N. Davis P. B. Y. Mori J. O. Eib</p>	<p>Principal Investigator Testing and Analysis Film and Specimen Preparation Film and Specimen Preparation</p>
---	--

Accession For	
NTIS CRA&I	<input checked="" type="checkbox"/>
DTIC TAB	<input type="checkbox"/>
Unannounced	<input type="checkbox"/>
Justification .....	
By .....	
Distribution /	
Availability Codes	
Dist	Avail and/or Special
A-1	

## TABLE OF CONTENTS

	<u>PAGE</u>
1.0 SUMMARY AND INTRODUCTION	
1.1 Summary	1
1.2 Introduction	2
2.0 TECHNICAL DISCUSSION	
2.1 Adhesive Resin Candidate Selection	2
2.2 Preparation of Adhesive Films	6
2.3 Preparation of Test Specimens	8
2.4 Bond Strength Test and Analysis	9
2.4.1 Lap Shear Strength Test and Analysis	9
2.4.2 Crack Extension Test and Analysis	14
2.4.3 Peel Strength Test and Analysis	16
3.0 CONCLUSION AND RECOMMENDATIONS	
3.1 Conclusions	28
3.2 Recommendations	29
4.0 REFERENCES	30
5.0 APPENDICES	31

## LIST OF FIGURES

<u>FIGURE</u>		<u>PAGE</u>
2.3.1	Mechanical Test Specimens	7
2.4.1	Data Summary for X-PQ Adhesive, 602K (625°F) Cure Cycle	17
2.4.2	Data Summary for PPQ-2501 Adhesive, 602K (625°F) Cure Cycle	18
2.4.3	Data Summary for PPQ-HC Adhesive, 602K (625°F) Cure Cycle	19
2.4.4	Data Summary for PPQ-2501 Adhesive, 644K (700°F) Cure Cycle	20
2.4.5	Data Summary for PPQ-HC Adhesive, 644K (700°F) Cure Cycle	21
2.4.6	Single Lap Shear Strength Versus Temperature (PPQ-2501)	22
2.4.7	Single Lap Shear Strength Versus Temperature (PPQ-HC)	23
2.4.8	Single Lap Shear Strength After Humidity Exposure	24
2.4.9	Crack Extension After Humidity Exposure (PPQ-2501)	25
2.4.10	Crack Extension After Humidity Exposure (PPQ-HC)	26
2.4.11	Crack Extension Versus Exposure Time at 505K (450°F)	27

## LIST OF TABLES

<u>TABLE</u>		<u>PAGE</u>
1.2.1	Test Matrix	4
2.1.1	PPQ Lap Shear Strength	5
5.0.1	X-PQ Room Temperature Exposure, Individual Test Values	32
5.0.2	X-PQ 1000 Hour Exposure, Individual Test Values 602K (625°F) Cure Cycle	33
5.0.3	X-PQ 3000 Hour Exposure, Individual Test Values, 602K (625°F) Cure Cycle	34
5.0.4	X-PQ Crack Extension, Individual Test Values, 602K (625°F) Cure Cycle	35
5.0.5	PPQ-2501 Room Temperature Exposure, Individual Test Values, 602K (625°F) Cure Cycle	36
5.0.6	PPQ-2501 1000 Hour Exposure, Individual Test Values, 602K (625°F) Cure Cycle	37
5.0.7	PPQ-2501 3000 Hour Exposure, Individual Test Values, 602K (625°F) Cure Cycle	38
5.0.8	PPQ-2501 Crack Extension, Individual Test Values, 602K (625°F) Cure Cycle	39
5.0.9	PPQ-HC Room Temperature Exposure, Individual Test Values, 602K (625°F) Cure Cycle	40
5.0.10	PPQ-HC 1000 Hour Exposure, Individual Test Values, 602K (625°F) Cure Cycle	41
5.0.11	PPQ-HC 3000 Hour Exposure, Individual Test Values, 602K (625°F) Cure Cycle	42
5.0.12	PPQ-HC Crack Extension, Individual Test Values 602K (625°F) Cure Cycle	43
5.0.13	PPQ-2501 Room Temperature Exposure, Individual Test Values, 644K (700°F) Cure Cycle	44
5.0.14	PPQ-2501 1000 Hour Exposure, Individual Test Values, 644K (700°F) Cure Cycle	45
5.0.15	PPQ-2501 Crack Extension, Individual Test Values, 644K (700°F) Cure Cycle	46

LIST OF TABLES (Continued)

<u>TABLE</u>		<u>PAGE</u>
5.0.16	PPQ-HC Room Temperature Exposure, Individual Test Values, 644K (700°F) Cure Cycle	47
5.0.17	PPQ-HC 1000 Hour Exposure, Individual Test Values, 644K (700°F) Cure Cycle	48
5.0.18	PPQ-HC Crack Extension, Individual Test Values, 644K (700°F) Cure Cycle	49

## 1.0 SUMMARY AND INTRODUCTION

### 1.1 Summary

This report documents the work performed by the Boeing Aerospace Company for the National Aeronautics and Space Administration, Langley Research Center, under contract NAS1-15605 - Phase IV. The primary objective of this program was to evaluate three polymers as structural adhesives for bonding 6Al-4V titanium for long-term applications at 505K (450°F). The three polymers evaluated for adhesive properties included; (1) a crosslinkable polyquinoxaline (X-PQ) from NASA Langley, (2) polyphenylquinoxaline (PPQ-2501) from King Mar Laboratories, and (3) polyphenylquinoxaline (PPQ-HC) from Hunt Chemical Corporation. Surface preparation for the titanium was 10 volt chromic acid anodize (CAA) according to Boeing Specification BAC 5890, "Anodizing of Titanium for Adhesive Bonding". The original test matrix consisted of lap shear, crack extension, and climbing drum peel specimens of the three PPQ adhesives cured at 602K (625°F) and evaluated at initial test temperatures from 219K (-67°F) to 505K (450°F). Testing was also completed after stressed Skydrol exposure, humidity exposure, and long term aging at 450K (350°F) and 505K (450°F). A limited evaluation of PPQ-2501 and PPQ-HC adhesives was also completed on lap shear and crack extension specimens after a 644K (700°F) cure, a portion of this work was completed on Boeing Independent Research and Development Programs.

The three adhesive candidates exhibited varying strengths when exposed to the different thermal and environmental conditions. All three polymers performed well at initial test temperatures from 219K (-67°F) to 505K (450°F). The 644K (700°F) cured adhesives generally exhibited superior shear strengths. In addition, after combined elevated temperature/humidity exposure the 644K (700°F) cured adhesives retained a greater percentage of their initial shear and toughness properties than comparable 602K (625°F) cured adhesives. The PPQ polymers also performed well after 3000 hours exposure at 450K (350°F). Some degradation was apparent after stressed/unstressed 505K (450°F) exposure especially for the 602K (625°F) cured polymers. X-PQ exhibited superior resistance to Skydrol in comparison to PPQ-2501/PPQ-HC under all process conditions used.

## 1.2 Introduction

The purpose of this program was to evaluate three phenylquinoxaline polymers as high temperature structural adhesives. These included an experimental crosslinkable polymer (X-PQ) from NASA-Langley and two experimental materials from King Mar Laboratories (PPQ-2501) in Encinitas, CA and Hunt Chemical Corporation (PPQ-HC) in Providence, R.I.

The basic approach to this study was to convert the supplied polymers to a usable thin adhesive film by impregnating on 112E-glass (A1100 finish). Titanium (6Al-4V) adherends were surface treated using the Boeing developed 10 volt chromic acid anodization process (BAC 5890, "Anodizing of Titanium for Adhesive Bonding"). The initial cure conditions for the polymers was a modification of one used in previous program efforts (Ref. 1). After fabrication, lap shear, crack extension and drum peel specimens were subjected to various environmental exposures and then tested according to the test matrix shown in Table 1.2.1. The program plan included testing at temperatures from 219K (-67°F) to 505K (450°F) before and after exposure to humidity and aircraft fluid (Skydrol). Additional lap shear and crack extension test specimens were also fabricated and tested utilizing the Reference 1 cure cycle.

This report is primarily organized to compare test results from the three adhesive candidates, additional comparisons are also made between the two cure cycles used. Average test values, as well as individual specimen values are tabulated along with comparisons between the performance of the candidates. Conclusions are also drawn from the data generated, and recommendations are made for further work.

## 2.0 TECHNICAL DISCUSSION

This section describes the detailed technical effort that was conducted on this program.

### 2.1 Adhesive Resin Candidate Selection

The candidates for evaluation included X-PQ, PPQ-2501 and PPQ-HC. The chemical structure of X-PQ is shown below:

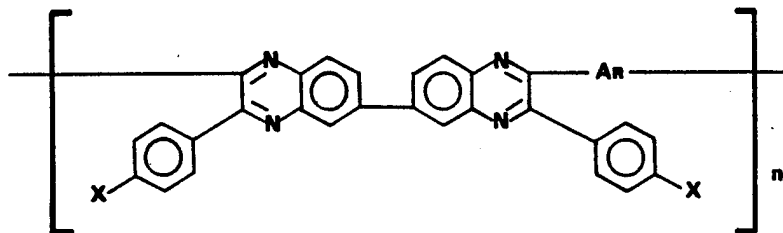

where 80% of Ar =  
and x = H

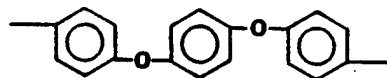

20% of Ar =

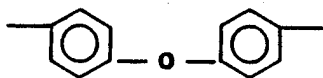

and

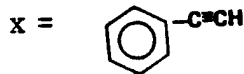

At high temperatures, the pendant phenylethynyl groups react to provide crosslinking (Ref. 2). The chemical structure of PPQ-2501 and PPQ-HC is shown below.

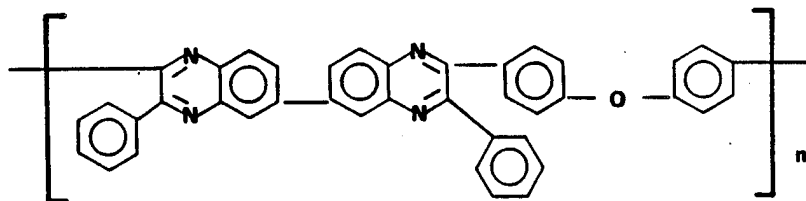

The polyphenylquinoxaline sample from NASA-Langley Research Center, designated X-PQ, sample number 962-79-S, was received as 18.3% solids in a solvent solution of m-cresol/xylene (1:1 mixture). The polymer had an inherent viscosity of 0.55 dl/g and a glass transition temperature of 603K (625°F).

The polyphenylquinoxaline sample from King Mar Laboratories (Encinitas, California), designated PPQ-2501 sample number 85-035, was received as 20% solids in a solvent solution of m-cresol/xylene (1:1 mixture). The polymer had an inherent viscosity of 0.80 dl/g and a glass transition temperature of 563K (554°F).

TABLE 1.2.1

PROGRAM TEST MATRIX  
602K (625°F) CURE CYCLE

TEST CONDITION (EXPOSURE TIME)	TEST SPECIMEN	NUMBER OF SPECIMENS PREPARED FROM EACH ADHESIVE SYSTEM
Ambient initial	Lap Shear	5
	Crack Extension	4
	Climbing Drum	3
219K (-67°F) (initial)	Lap Shear	5
Ambient after exposure to 322K(120°F)/95% RH (1000 hours)	Lap Shear	5
	Crack Extension	4
	Climbing Drum	3
Ambient after exposure to Skydrol, stressed at ambient (1000 hours)	Lap Shear	5
450K (350°F) initial	Lap Shear	5
	Crack Extension	4
	Climbing Drum	3
450K (350°F) after 1000 and 3000 hours at 450K (350°F) in air	Lap Shear	5
	Crack Extension	4
450K (350°F) after exposure to Skydrol, stressed at RT (1000 hours)	Lap Shear	5
450K (350°F) after exposure to 322K (120°F)/95% RH (1000 hours)	Lap Shear	5
	Crack Extension	4
450K (350°F) stressed to determine creep resistance (3000 hours)	Lap Shear	5
505K (450°F) initial	Lap Shear	5
	Crack Extension	4
505K (450°F) after 1000 and 3000 hours at 505K (450°F) in air	Lap Shear	5
	Crack Extension	4
505K (450°F), stressed to determine creep resistance (3000 hours)	Lap Shear	5

The polyphenylquinoxaline sample from Hunt Chemical Corporation (Providence, Rhode Island), designated PPQ-HC, sample number 1344-12-A, was supplied as 20% solids in a solvent solution of m-cresol/xylene (1:1 mixture). The polymer has an inherent viscosity of 0.6 dl/g. The glass transition temperature of this polymer was not determined.

A polyphenylquinoxaline of the same chemical structure as PPQ-2501 and PPQ-HC was supplied by NASA-Langley during Phase I and Phase II of this program. The following cure cycle was employed to fabricate the previously bonded specimens from the NASA-Langley supplied polymer.

1. Apply vacuum and 1.38 MPa (200 psi) autoclave pressure.
2. Heat to 644K (700°F) at 1.7 -2.8K (3-5°F)/minute.
3. Hold at 644K (700°F) for 60 minutes.
4. Cool to below 339K (150°F) before releasing pressure.

A summary of adhesive performance is given in Table 2.1.1 as excerpted from the Phase I and Phase II final report (Table 2.3.1.1, page 55, Ref. 1).

TABLE 2.1.1  
PPQ LAP SHEAR STRENGTH

<u>TEST CONDITION</u>	<u>LAP SHEAR</u>	
	<u>MPa</u>	<u>(psi)</u>
Ambient Initial	28.1	(4080)
219K (-67°F) Initial	31.6	(4580)
505K (450°F) Initial	20.1	(2930)
505K (450°F) After Exposure to 505K (450°F) in Air		
3000 Hours	20.6	(2990)
6000 Hours	19.4	(2820)

Purchased polymers of the same chemical structure were evaluated again in the present Phase IV to determine if the adhesive performance would be the same as the NASA-Langley supplied polymers. King Mar Laboratories and Hunt Chemical Corporation are potential commercial sources for a polyphenylquinoxaline.

## 2.2 Preparation of Adhesive Films

The three polymers were processed into film form by impregnating 112 E-glass (A1100 finish) with the polymer solution. Prior to processing, the glass fabric was oven dried to remove any residual moisture and then stretched tightly on an aluminum frame to facilitate processing.

The initial adhesive coat applied to the glass fabric was a dilute adhesive solution of 3 parts solvent (1:1 m-cresol/xylene) to 1 part supplied adhesive solution. The thinned solution was applied by brush onto the fabric, and the film was subsequently oven dried at 339K (150°F) for 1 hour. Additional coats of the undiluted, unfilled polymer solution were then applied by a plastic sweep to alternate sides of the fabric until the desired film thickness of 0.0254 cm (.010 inch) was achieved. Each individual adhesive coating was also oven dried at 339K (150°F) for 1 hour. The finished adhesive film was oven dried in 14K (25°F) increments up to 458K (365°F). The film was held at each increment for 1/2 hour, and held at the final temperature for 4-5 hours.

To check the adhesive film processing characteristics, the film's volatile content, resin content and flow parameters were determined. The film volatile content was measured gravimetrically before and after exposure to 616K (650°F) for 1/2 hour. Film resin content was also measured gravimetrically before and after exposure to 922K (1200°F) in air for 1 hour. Each of the adhesive films were also tested for resin flow using a 3.55 cm (1.4 inch) diameter film disk pressed between two sheets of aluminum. Resin flow was measured after a 2 hour exposure time at 589K (600°F) and 1.4 MPa (200 psi) in a hydraulic press. Results for each of the adhesive films are shown below:

Adhesive	Volatile Content (Weight Percent)	Resin Content (Weight Percent)	Flow Test (Increase in Diameter/Percent)
X-PQ	3.00	68	11
PPQ-2501	2.98	73	19
PPQ-HC	2.92	70	4

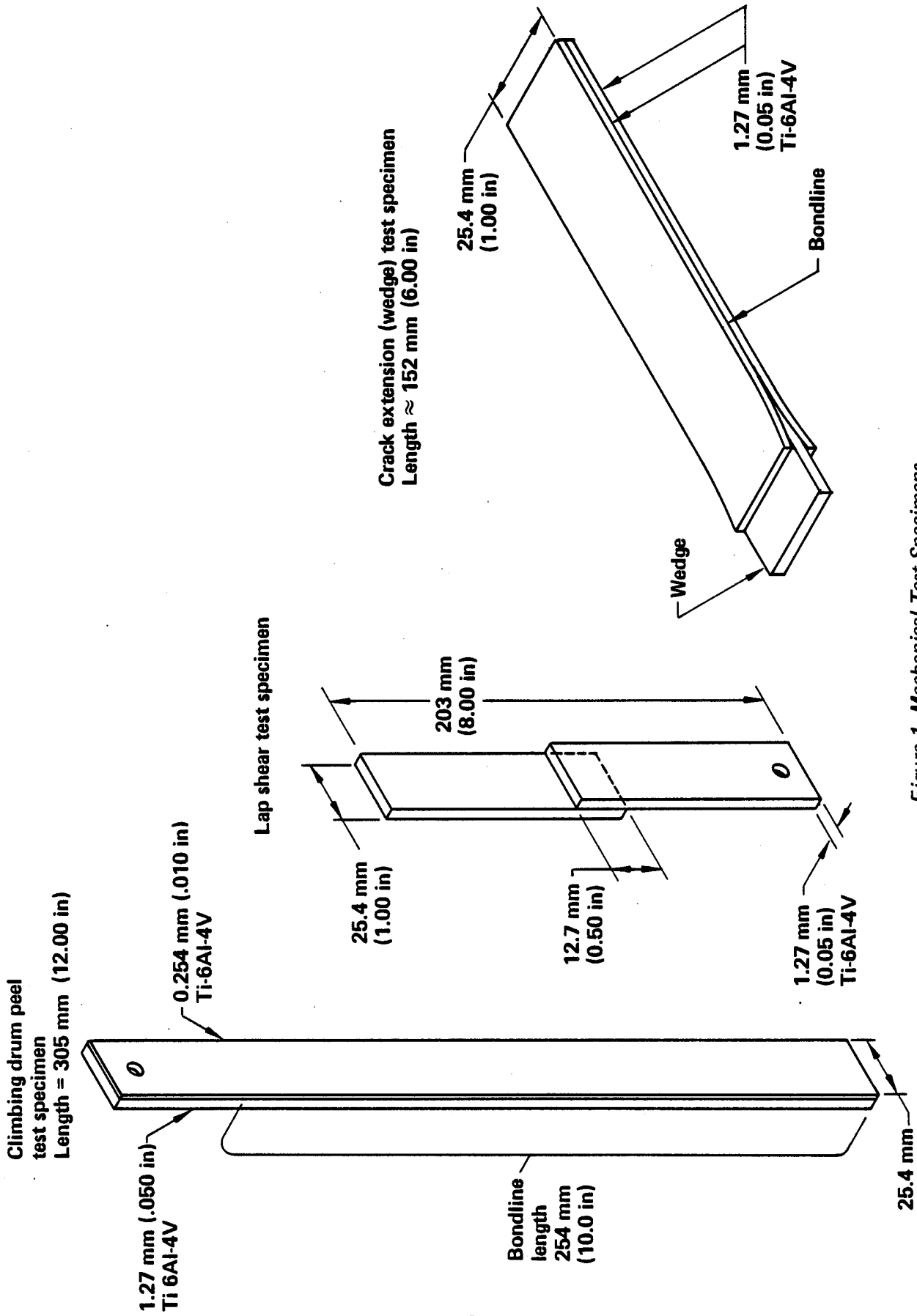

Figure 1. Mechanical Test Specimens

## 2.3 Preparation of Test Specimens

Three different types of test specimens were prepared utilizing the 602K (625°F) cure cycle; single lap shear, crack extension and climbing drum peel. For the limited evaluation of the Reference 1 cure cycle (644K (700°F)), single lap shear and crack extension specimens were prepared. The configuration of each specimen is shown in Figure 2.3.1. For all specimens, the adherends were 6Al-4V titanium alloy and the surface preparation method was 10 volt chromic acid anodize according to BAC 5890. Immediately after surface preparation, each specimen was primed with a dilute adhesive solution and then oven dried at 436K (325°F) for 1 hour. The test specimens were then assembled by cutting appropriate sized pieces of film, assembling the titanium specimens and film in bonding jigs, and then vacuum bagging the specimens. Initially, test specimens were autoclave cured according to the following schedule:

### 602K (625°F) Cure Cycle

1. Apply full vacuum.
2. Increase pressure to 1.4 MPa (200 psi)
3. Increase temperature to 602K (625°F) at 3K/minute (5°F/minute)
4. Hold at temperature for 90 minutes
5. Cool under pressure to 339K (150°F) at 5K/minute (9°F/minute)
6. Release pressure and vacuum

This cure cycle differs from that previously used in Reference 1 as noted earlier. The compromise in cure cycles was made to accommodate the Reference 1 process specification which incorporated both PPQ and LARC-TPI in the same cure cycle. In addition, the lower cure temperature was utilized to potentially improve the adhesives structural life during extended thermal exposure. The data discussed later will show that the compromise cure cycle resulted in inferior bond strengths.

Additional test specimens (lap shear, crack extension) were fabricated from PPQ-2501 and PPQ-HC and autoclave cured according to the following schedule previously utilized in Reference I.

### 644K (700°F) Cure Cycle

1. Apply full vacuum
2. Increase pressure to 1.4 MPa (200 psi)
3. Increase temperature to 644K (700°F) at 3K/minute (5°F/minute)
4. Hold at 644K (700°F) for 60 minutes
5. Cool under pressure to 339K (150°F) at 5K/minute (9°F/minute)
6. Release pressure and vacuum

### 2.4 Bond Strength Test and Analysis

#### 2.4.1 Lap Shear Strength Test and Analysis

### 602K (625°F) Cure Cycle

Shear strengths at ambient temperature, 219K (-67°F), 450K (350°F) and 505K (450°F) were obtained after a 10 minute soak at each temperature. Additional testing was also completed after humidity exposure 322K (120°F)/95% R.H., Skydrol exposure, and long term aging at 450K (350°F) and 505K (450°F). Lap shear specimens were also stressed at 25% of ultimate strength to determine creep resistance at 450K (350°F) and 505K (450°F).

A summary of lap shear strengths for X-PQ, PPQ-2501 and PPQ-HC are listed in Figures 2.4.1, 2.4.2 and 2.4.3, respectively. Individual lap shear results are also tabulated in Tables 5.0.1 through 5.0.12.

### 644K (700°F) Cure Cycle

Shear strengths at ambient temperature, 450K (350°F) and 505K (450°F) were obtained after a 10 minute soak at each temperature. Additional testing was also completed after humidity exposure 322K (120°F)/95% R.H., Skydrol exposure, and stressed (25% of ultimate strength) exposure at 505K (450°F).

A summary of lap shear strengths for PPQ-2501 and PPQ-HC are listed in Figures 2.4.4 and 2.4.5, respectively. Individual lap shear results are also tabulated in Tables 5.0.13 through 5.0.18.

Comparison of lap shear results for the three adhesive candidates are presented in Figures 2.4.6, 2.4.7, and 2.4.8 and reveal the following trends.

#### X-PQ Test Results: 602K (625°F) Cure Cycle

X-PQ exhibited superior initial shear strengths of all three candidates cured at 602K (625°F), at test temperatures from 219K (-67°F) to 505K (450°F). Comparable shear strengths were also obtained for X-PQ after stressed Skydrol exposure (1000 hours). However, humidity exposure (322K (120°F)/95% R.H.) for 1000 hours resulted in a 35% to 40% decrease in shear strength at test temperatures of 293K (68°F) and 450K (350°F). This low strength retention in the presence of moisture was probably due to the cure cycle used as discussed previously. In all three cases the failure mode was primarily cohesive.

Long term exposure (1000 to 3000 hours) at 450K (350°F) in air caused no appreciable degradation in the shear strength of X-PQ, although the failure mode changed from about 87% cohesive to about 72% cohesive with increasing exposure time. In contrast to the long term exposure at 450K (350°F), similar tests at 505K (450°F) resulted in a substantial degradation in shear strength. Again, the cure cycle used did not allow full strength potential - probably due to residual m-cresol/xylene solvent retained.

Lap shear strength decreased from an initial 505K (450°F) value of 16.1 MPa (2330 psi) to 13.4 MPa (1950 psi) after 1000 hours exposure, and 4.7 MPa (680 psi) after 3000 hours exposure. Two test specimens also failed prematurely during testing after 3000 hours exposure. The failure mode changed from about 62% cohesive at 1000 hours to about 20% cohesive after 3000 hours.

Additional specimens stressed to determine creep at 450K (350°F) exhibited no adhesive creep after 3000 hours exposure. Similar test specimens stressed (25% of ultimate) at 505K (450°F) failed adhesively after 2832 hours exposure.

#### X-PQ Test Results: 644K (700°F) Cure Cycle

X-PQ lap shear specimens were not fabricated using the 644K (700°F) cure cycle, because of the limited supply of this experimental polymer.

## PPQ-2501 Test Results: 602K (625°F) Cure Cycle

PPQ-2501 exhibited similar initial shear strengths at test temperatures from 219K (-67°F) to 450K (350°F) when compared to the other adhesive candidates. However, the failure mode was primarily adhesive. The initial 505K (450°F) shear strengths were lower than expected at 8.1 MPa (1180 psi), although the failure mode was 80% cohesive. This possibly indicates the need for the use of the higher cure temperature (700°F/60 minutes) or postcure.

Humidity exposure (322K (120°F)/95% R.H.) for a period of 1000 hours resulted in a 20% to 24% reduction in initial properties at test temperatures of 293K (68°F) and 450K (350°F) respectively. Test specimens failed adhesively (30% cohesive) at 293K (68°F) and 70% cohesive at 450K (350°F).

All ten PPQ-2501 specimens failed adhesively during stressed Skydrol exposure at approximately 120 hours.

Long term exposure (1000-3000 hours) at 450K (350°F) in air resulted in an actual increase in shear strength when compared to the initial 450K (350°F) values. After 1000 and 3000 hours exposure time the shear strength increased by 6% and 21%, respectively. The failure mode in both cases was 100% cohesive.

Long term exposure at 505K (450°F) in air also resulted in an increase in shear strength when compared to the initial 505K (450°F) values. The shear strength increased by 93% after 1000 hours exposure and 65% after 3000 hours exposure. The failure mode was also primarily cohesive. This possibly indicates the need for additional post-cure studies to optimize the initial adhesive properties. The evolution of residual solvent (m-cresol) during long term aging could presumably account for this increase in shear strength.

Lap shear specimens stressed at 25% of ultimate to determine creep at 450K (350°F) exhibited no adhesive creep after 3000 hours exposure. Similar specimens stressed at 505K (450°F) failed cohesively (100%) after 120 hours exposure.

## PPQ-2501 Test Results: 644K (700°F) Cure Cycle

PPQ-2501 exhibited similar initial shear properties at test temperatures from ambient (68°F) to 505K (450°F) to PPQ-HC utilizing the same process conditions. Initial 450K (350°F) shear strengths actually increased by 14% over ambient initial values. In addition, PPQ-2501 retained over 85% of its ambient initial shear strength when tested at 505K (450°F) initial. In all cases the failure mode was primarily cohesive.

Humidity exposure (322K (120°F)/95% R.H.) for a period of 1000 hours resulted in a 8% reduction in initial properties at 293K (68°F). Stressed Skydrol exposure (1000 hours) resulted in a small decrease in shear strength when compared to initial values. At ambient test conditions the shear strength was 26.3 MPa (3820 psi) which decreased to 21.9 MPa (3170 psi) at the 450K (350°F) test condition. All test specimens failed cohesively after humidity or Skydrol exposure.

Lap shear specimens stressed at 25% of ultimate strength to determine creep at 505K (450°F) exhibited no creep after 3000 hours exposure.

## PPQ-2501 Cure Cycle Comparison

In general, the Reference I cure cycle (644K (700°F)) resulted in superior shear properties at all test conditions to comparable specimens cured at 602K (625°F). Initial shear strengths increased by 33%, 59%, and 216% at ambient, 450K (350°F), and 505K (450°F) test temperatures respectively when cured at 644K (700°F) as compared to the 602K (625°F) cure cycle. Additional 644K (700°F) cured test specimens in humidity exposure (1000 hours), retained a significant amount of their ambient initial shear strength than comparable 602K (625°F) cured specimens. In contrast to the 602K (625°F) cured specimens, which failed in stressed Skydrol and 505K (450°F) exposure, all 644K (700°F) cured test specimens survived intact.

## PPQ-HC Test Results: 602K (625°F) Cure Cycle

PPQ-HC exhibited initial lap shear strengths that were intermediate of those recorded for X-PQ and PPQ-2501. PPQ-HC retained 85% of its initial strength at 450K (350°F) and 54% at 505K (450°F). The failure mode for all initial testing from 219K (-67°F) to 505K (450°F) was 50% cohesive.

Humidity exposure (322K (120°F)/95% R.H.) for 1000 hours caused no appreciable degradation of the initial shear strengths at ambient test conditions. However, at 450K (350°F) test conditions, PPQ-HC retained only 39% of its initial 450K (350°F) shear strength with 80% adhesive failures in the test specimens.

Stressed Skydrol exposure (1000 hour) also resulted in substantial decrease in shear strength when compared to initial values. At ambient test conditions the shear strength was 12.81 MPa (1860 psi), which decreased to 1.4 MPa (210 psi) at the 450K (350°F) test condition. After Skydrol exposure, all specimens failed adhesively.

Long term exposure (1000-3000 hours) at 450K (350°F) resulted in an increase of lap shear strength when compared to initial values. After 1000 hours exposure, shear strength was 29.7 MPa (4300 psi) or 153% of the initial 450K (350°F) value. Shear strength after 3000 hours exposure was 25.3 MPa (3670 psi) or 130% of the initial 450K (350°F) value. All failures were primarily cohesive. The increase in strength is attributed to adhesive resin crosslinking/toughening due to thermal aging. This indicates that the initial cure should be at a higher temperature or a post cure is required. The lower strengths at some exposure conditions is attributed to residual m-cresol which may plasticize the adhesive or contribute to incompatibility with the adherend surface.

Long term exposure (1000-3000 hours) at 505K (450°F) also resulted in an increase in shear strength when compared to initial values. After 1000 and 3000 hours exposure, shear strength was 113% and 119% of the initial 505K (450°F) shear strength, respectively. The failure modes were about 60% cohesive.

Additional specimens stressed at 25% of ultimate to determine creep at 450K (350°F) exhibited no adhesive creep after 3000 hours exposure. Similar test specimens stressed at 505K (450°F) failed cohesively after 120 hours.

#### PPQ-HC Test Results: 644K (700°F) Cure Cycle

PPQ-HC exhibited initial lap shear strengths of 27.7 MPa (4020 psi), 28.2 MPa (4090 psi), and 24.1 MPa (3490 psi) at test temperatures of ambient, 450K (350°F), and 505K (450°F) respectively. The failure mode of the ambient initial test specimens was approximately 40% cohesive, with the 450K (350°F) and 505K (450°F) initial test specimens failing 95% cohesively.

Humidity exposure (322K (120°F)/95% R.H.) for a period of 1000 hours resulted in a 20% reduction in initial properties at 293K (68°F). Stressed Skydrol exposure (1000 hours) also resulted in a decrease in shear strength when compared to initial values. At ambient test conditions after humidity exposure, shear strength was 23.4 MPa (3390 psi) which decreased to 17.2 MPa (2490 psi) at the 450K (350°F) test condition. Additional specimens stressed at 25% of ultimate strength to determine creep at 450K (350°F) exhibited no creep after 1000 hours exposure.

### PPQ-HC Cure Cycle Comparison

In general, the Reference I cure cycle (644K (700°F)) resulted in superior shear properties at all test conditions to comparable specimens cured at 602K (625°F). Initial shear strengths increased by 22%, 24%, and 95% at ambient, 450K (350°F) and 505K (450°F) test temperatures when cured at 644K (700°F) when compared to the 602K (625°F) cure cycle. Additional test specimens, after humidity exposure, exhibited similar shear strengths for both cure cycles, however, the 602K (625°F) cured specimens retained a greater majority of its initial strength. Lap shear specimens stressed at 25% of ultimate strength in Skydrol, generally retained a greater majority of their shear strength when cured at 644K (700°F).

#### 2.4.2 Crack Extension Test and Analysis

##### 602K (625°F) Cure Cycle

Evaluation was performed at ambient temperature, 450K (350°F) and 505K (450°F). Additional evaluation was performed after humidity exposure (322K (120°F)/95% R.H.) and long term aging at 450K (350°F) and 505K (450°F).

A summary of crack extension results for X-PQ, PPQ-2501 and PPQ-HC are listed in Figures 2.4.1, 2.4.2 and 2.4.3, respectively. Individual crack extension values are also tabulated in Tables 5.0.1 through 5.0.12.

Comparison of the crack extension values for each of the three adhesive systems tested reveals the following trends. In general, crack extension values increased with increasing test temperature. X-PQ crack extension specimens when examined at 450 K (350°F) and 505K (450°F), increased only 8% and 11%, respectively when compared to initial values. A more noticeable increase was noted for PPQ-2501 with increases in crack extension over ambient initial values of 11% at 450K (350°F), and 27% at

505K (450°F). PPQ-HC remained relatively stable over the same range, with a 6% increase in crack extension recorded at 450K (350°F), and only a 1% increase at 505K (450°F), when compared to 293K (68°F) initial values.

After 1000 hour humidity exposure an increase in crack growth was noted with a corresponding increase in crack growth with test temperature as previously observed. When compared to 293K (68°F) initial values, the growth at 293K (68°F) after humidity exposure revealed the following results.

- o X-PQ 57% increase in crack growth
- o PPQ-2501 61% increase in crack growth
- o PPQ-HC 46% increase in crack growth

When compared to 450K (350°F) initial values, examination of test specimens at 450K (350°F) after humidity exposure revealed the following results:

- o X-PQ 172% increase in crack growth
- o PPQ-2501 62% increase in crack growth
- o PPQ-HC 59% increase in crack growth.

After long term exposure (3000 hours) at 450K (350°F), X-PQ had an 8% increase in crack growth when compared to 450K (350°F) initial values. PPQ-2501 and PPQ-HC exhibited a 20% and 36% increase in crack growth when compared to 450K (350°F) initial values, respectively.

Long term exposure (3000 hours) at 505K (450°F) resulted in a more dramatic increase in crack growth values when compared to initial 505K (450°F) results. X-PQ exhibited an 80% increase, PPQ-2501 a 34% increase, and PPQ-HC a 47% increase in crack growth after 3000 hour 505K (450°F) exposure.

#### 644K (700°F) Cure Cycle

Evaluation was performed at ambient initial, after humidity exposure and long term aging at 505K (450°F).

A summary of the crack extension results for PPQ-2501 and PPQ-HC are listed in Figures 2.4.4 and 2.4.5. Individual crack extension values are also tabulated in Tables 5.0.13 through 5.0.18.

Comparison of the crack extension values for PPQ-2501 and PPQ-HC processed at 644K (700°F), reveals the following trends. In general, crack extension values increased with increasing temperature and exposure time. Although humidity exposure had a more severe effect on crack extension values than long term exposure at 505K (450°F). After 1000 hour humidity exposure, the crack growth at 293K (68°F) when compared to the initial values, revealed the following results.

- o PPQ-2501 21% increase in crack growth
- o PPQ-HC 16% increase in crack growth

### Cure Cycle Comparison

Crack extension values for both cure cycles utilized are presented in Figures 2.4.9, 2.4.10, and 2.4.11.

Comparison of the crack extension values for PPQ-2501 and PPQ-HC at both 602K (625°F) and 644K (700°F) process conditions indicated the following: Ambient initial 293K (68°F) results were essentially identical. However, crack extension values after 1000 hour humidity exposure were much greater for the 602K (625°F) cured adhesives than the 644K (700°F) cured adhesives. Additional test specimens exposed at 505K (450°F) for 1000 hours showed similar results. In general, 644K (700°F) cured test specimens were significantly tougher than comparable 602K (625°F) cured test specimens.

### 2.4.3 Peel Strength Test and Analysis

#### 602K (625°F) Cure Cycle

Peel strength was recorded at ambient temperature, 450K (350°F) and 505K (450°F) after a ten minute soak at temperature.

A summary of climbing drum peel strength values for X-PQ, PPQ-2501 and PPQ-HC are listed in Figures 2.4.1, 2.4.2 and 2.4.3 respectively. Individual peel strength values are also tabulated in Tables 5.0.1 through 5.0.12. Comparison of the climbing drum peel strengths for the three adhesive candidates cured at 602K (625°F) revealed no general trends with respect to exposure conditions and resulting peel values. The failure mode was primarily adhesive.

FIGURE 2.4.1

DATA SUMMARY FOR X-PQ ADHESIVE 602K (625°F) CURE CYCLE

TEST CONDITION	LAP SHEAR		CRACK EXTENSION		CLIMBING DRUM PEEL	
	MPa	(psi)	mm	(inches)	N.M.	(in.lb.)
219K (-67°F) Initial	29.9	(4340)	—	—	—	—
Ambient (68°F) Initial	26.6	(3850)	22.1	(0.87)	1.3	(11.7)
450K (350°F) After Exposure to 450K (350°F) in Air						
Initial	25.5	(3700)	23.9	(0.94)	5.6	(49.7)
1000 Hours	24.6	(3570)	25.7	(1.01)	—	—
3000 Hours	20.6	(2980)	25.9	(1.02)	—	—
450K (350°F) Stressed at 25% of Ultimate to Determine Creep Resistance						
3000 Hours	N		—	—	—	—
505K (450°F) After Exposure to 505K (450°F) in Air						
Initial	16.1	(2330)	24.6	(0.97)	—	—
1000 Hours	13.4	(1950)	28.1	(1.11)	—	—
3000 Hours	4.7	(680)	44.2	(1.74)	—	—
505K (450°F) Stressed at 25% of Ultimate to Determine Creep Resistance						
3000 Hours	F		—	—	—	—
Ambient After Exposure to 322K (120°F)/95% R.H.						
Initial	26.6	(3850)	21.8	(0.86)	1.3	(11.7)
1000 Hours	16.6	(2400)	34.8	(1.37)	0.4	(3.5)
450K (350°F) After Exposure to 322K (120°F)/95% R.H.						
Initial	25.5	(3700)	25.3	(1.00)	—	—
1000 Hours	17.6	(2550)	66.8	(2.63)	—	—
Ambient After Exposure to Skydrol at Ambient, Stressed at 25% of Ultimate						
Initial	26.6	(3850)	—	—	—	—
1000 Hours	28.2	(4090)	—	—	—	—
450K (350°F) After Exposure to Skydrol at Ambient, Stressed at 25% of Ultimate						
Initial	25.5	(3700)	—	—	—	—
1000 Hours	24.1	(3490)	—	—	—	—

N - No creep recorded at 3000 Hours

F - Failed at 2832 hours

FIGURE 2.4.2

DATA SUMMARY FOR PPQ-2501 ADHESIVE 602K (625°F) CURE CYCLE

TEST CONDITION	LAP SHEAR MPa (psi)	CRACK EXTENSION mm (inches)	CLIMBING DRUM PEEL N.M. (in.lb.)
219K (-67°F) Initial	25.2 (3650)	—	—
Ambient (68°F) Initial	21.1 (3060)	22.8 (0.90)	0.6 (5.1)
450K (350°F) After Exposure to 450K (350°F) in Air			
Initial	20.0 (2900)	25.4 (1.00)	0.2 (2.0)
1000 Hours	21.2 (3080)	30.5 (1.20)	—
3000 Hours	24.1 (3490)	30.5 (1.20)	—
450K (350°F) Stressed at 25% of Ultimate to Determine Creep Resistance			
3000 Hours	N	—	—
505K (450°F) After Exposure to 505K (450°F) in Air			
Initial	8.1 (1180)	29.0 (1.14)	—
1000 Hours	15.6 (2260)	39.1 (1.54)	—
3000 Hours	13.4 (1950)	39.1 (1.54)	—
505K (450°F) Stressed at 25% of Ultimate to Determine Creep Resistance			
3000 Hours	F	—	—
Ambient After Exposure to 322K (120°F)/95% R.H.			
Initial	21.1 (3060)	22.4 (0.88)	0.6 (5.1)
1000 Hours	16.9 (2450)	36.6 (1.44)	0.4 (3.2)
450K (350°F) After Exposure to 322K (120°F)/95% R.H.			
Initial	20.0 (2900)	23.6 (0.93)	—
1000 Hours	15.3 (2220)	40.9 (1.61)	—
Ambient After Exposure to Skydrol at Ambient, Stressed at 25% of Ultimate			
Initial	21.1 (3060)	—	—
1000 Hours	F	—	—
450K (350°F) After Exposure to Skydrol at Ambient, Stressed at 25% of Ultimate			
Initial	20.0 (2900)	—	—
1000 Hours	F	—	—

N - No creep recorded at 3000 Hours

F - Failed after 120 hour exposure

FIGURE 2.4.3

DATA SUMMARY FOR PPQ-HC ADHESIVE 602K (625°F) CURE CYCLE

TEST CONDITION	LAP SHEAR		CRACK EXTENSION		CLIMBING DRUM PEEL	
	MPa	(psi)	mm	(inches)	N.M.	(in.lb.)
219K (-67°F) Initial	25.1	(3640)	—		—	
Ambient (68°F) Initial	22.8	(3300)	21.8	(0.86)	1.4	(12.5)
450K (350°F) After Exposure to 450K (350°F) in Air						
Initial	19.4	(2820)	23.1	(0.91)	1.9	(17.0)
1000 Hours	29.7	(4300)	27.4	(1.08)	—	
3000 Hours	25.3	(3670)	31.5	(1.24)	—	
450K (350°F) Stressed at 25% of Ultimate to Determine Creep Resistance						
3000 Hours	N		—		—	
505K (450°F) After Exposure to 505K (450°F) in Air						
Initial	12.3	(1790)	22.1	(0.87)	—	
1000 Hours	13.9	(2020)	32.5	(1.28)	—	
3000 Hours	14.6	(2110)	32.6	(1.29)	—	
505K (450°F) Stressed at 25% of Ultimate to Determine Creep Resistance						
3000 Hours	F		—		—	
Ambient After Exposure to 322K (120°F)/95% R.H.						
Initial	22.8	(3300)	22.5	(0.89)	1.4	(12.5)
1000 Hours	21.9	(3170)	31.8	(1.25)	1.9	(16.6)
450K (350°F) After Exposure to 322K (120°F)/95% R.H.						
Initial	19.4	(2820)	21.3	(0.84)	—	
1000 Hours	8.8	(1280)	36.8	(1.45)	—	
Ambient After Exposure to Skydrol at Ambient, Stressed at 25% of Ultimate						
Initial	22.8	(3300)	—		—	
1000 Hours	12.8	(1860)	—		—	
450K (350°F) After Exposure to Skydrol at Ambient, Stressed at 25% of Ultimate						
Initial	19.4	(2820)	—		—	
1000 Hours	1.4	(210)	—		—	

N - No creep recorded at 3000 Hours

F - Failed after 120 hour exposure

FIGURE 2.4.4

DATA SUMMARY FOR PPQ-2501 ADHESIVE 644K (700°F) CURE CYCLE

TEST CONDITION	LAP SHEAR		CRACK EXTENSION	
	MPa	(psi)	mm	(inches)
Ambient (68°F) Initial	28.0	(4060)	22.4	(0.88)
450K (350°F) Initial	31.9	(4620)	—	
505K (450°F) After Exposure to 505K (450°F) in Air				
Initial	23.9	(3460)	22.4	(0.88)
1000 Hours	—		24.6	(0.97)
3000 Hours	—		TBD	
505K (450°F) Stressed at 25% of Ultimate to Determine Creep Resistance				
3000 Hours	N		—	
Ambient After Exposure to 322K (120°F)/95% R.H.				
Initial	28.0	(4060)	22.4	(0.88)
1000 Hours	25.7	(3730)	27.2	(1.07)
450K (350°F) After Exposure to 322K (120°F)/95% R.H.				
Initial	—		20.6	(0.81)
1000 Hours	—		26.4	(1.04)
Ambient After Exposure to Skydrol at Ambient, Stressed to 25% of Ultimate				
Initial	28.0	(4060)	—	
1000 Hours	26.3	(3820)	—	
450K (350°F) After Exposure to Skydrol at Ambient, Stressed to 25% of Ultimate				
Initial	31.9	(4620)	—	
1000 Hours	21.9	(3170)	—	

N - No creep recorded at 3000 Hours

FIGURE 2.4.5

DATA SUMMARY FOR PPQ-HC ADHESIVE 644K (700°F) CURE CYCLE

TEST CONDITION	LAP SHEAR		CRACK EXTENSION	
	MPa	(psi)	mm	(inches)
Ambient (68°F) Initial	27.7	(4020)	21.6	(0.85)
450K (350°F) Initial	28.2	(4090)	—	
505K (450°F) After Exposure to 505K (450°F) in Air				
Initial	24.1	(3490)	21.6	(0.85)
1000 Hours	—		24.4	(0.96)
3000 Hours	—		TBD	
505K (450°F) Stressed at 25% of Ultimate to Determine Creep Resistance				
3000 Hours	N		—	
Ambient After Exposure to 322K (120°F)/95% R.H.				
Initial	27.7	(4020)	21.8	(0.86)
1000 Hours	22.0	(3190)	25.1	(0.99)
450K (350°F) After Exposure to 322K (120°F)/95% R.H.				
Initial	—		21.8	(0.86)
1000 Hours	—		25.7	(1.01)
Ambient After Exposure to Skydrol at Ambient, Stressed to 25% of Ultimate				
Initial	27.7	(4020)	—	
1000 Hours	23.4	(3390)	—	
450K (350°F) After Exposure to Skydrol at Ambient, Stressed to 25% of Ultimate				
Initial	28.2	(4090)	—	
1000 Hours	17.2	(2490)	—	

N - No creep recorded at 1000 Hours

**FIGURE 2.4.6.**  
**SINGLE LAP SHEAR STRENGTH VS TEMPERATURE (PPO-2501)**



**FIGURE 2.4.7.**  
**SINGLE LAP SHEAR STRENGTH VS TEMPERATURE (PPQ-HC)**

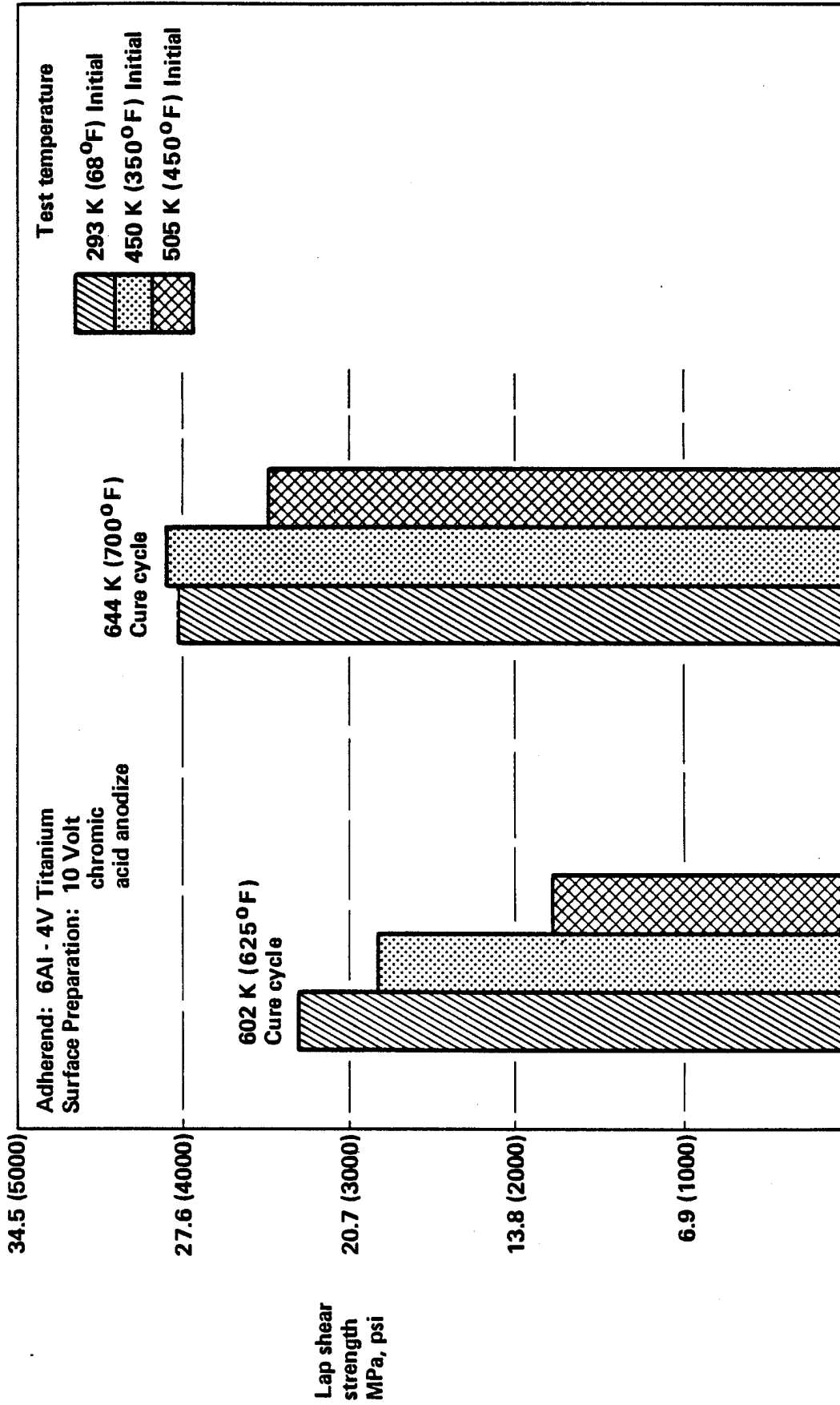

**FIGURE 2.4.8.**  
**SINGLE LAP SHEAR STRENGTH AFTER HUMIDITY EXPOSURE**  
**(1000 HOURS) 322 K (120° F)/95% RELATIVE HUMIDITY**

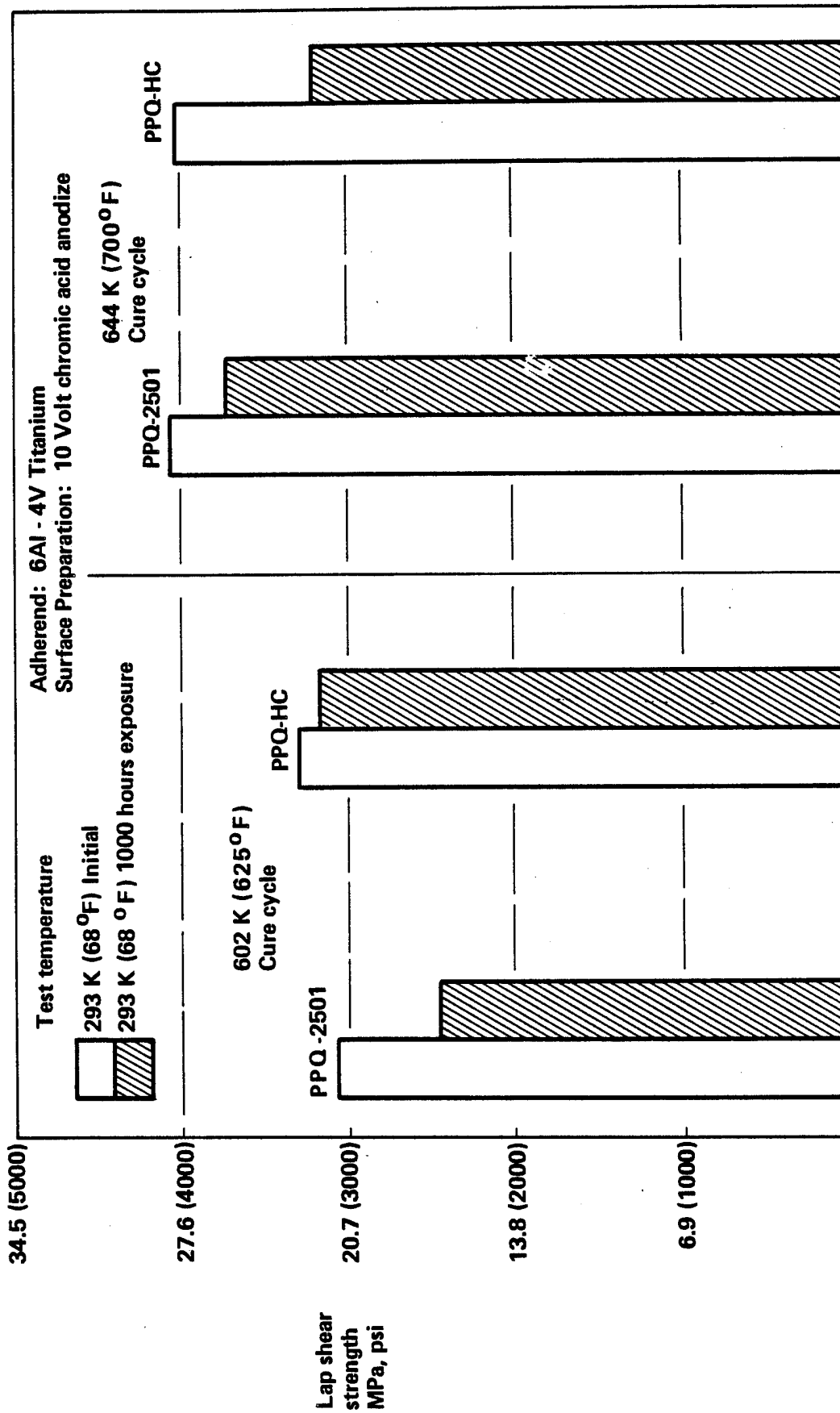

**FIGURE 2.4.9.**  
**CRACK EXTENSION AFTER HUMIDITY EXPOSURE (1000 HOURS)**  
**322 K (120° F)/95% RELATIVE HUMIDITY (PPO-2501)**

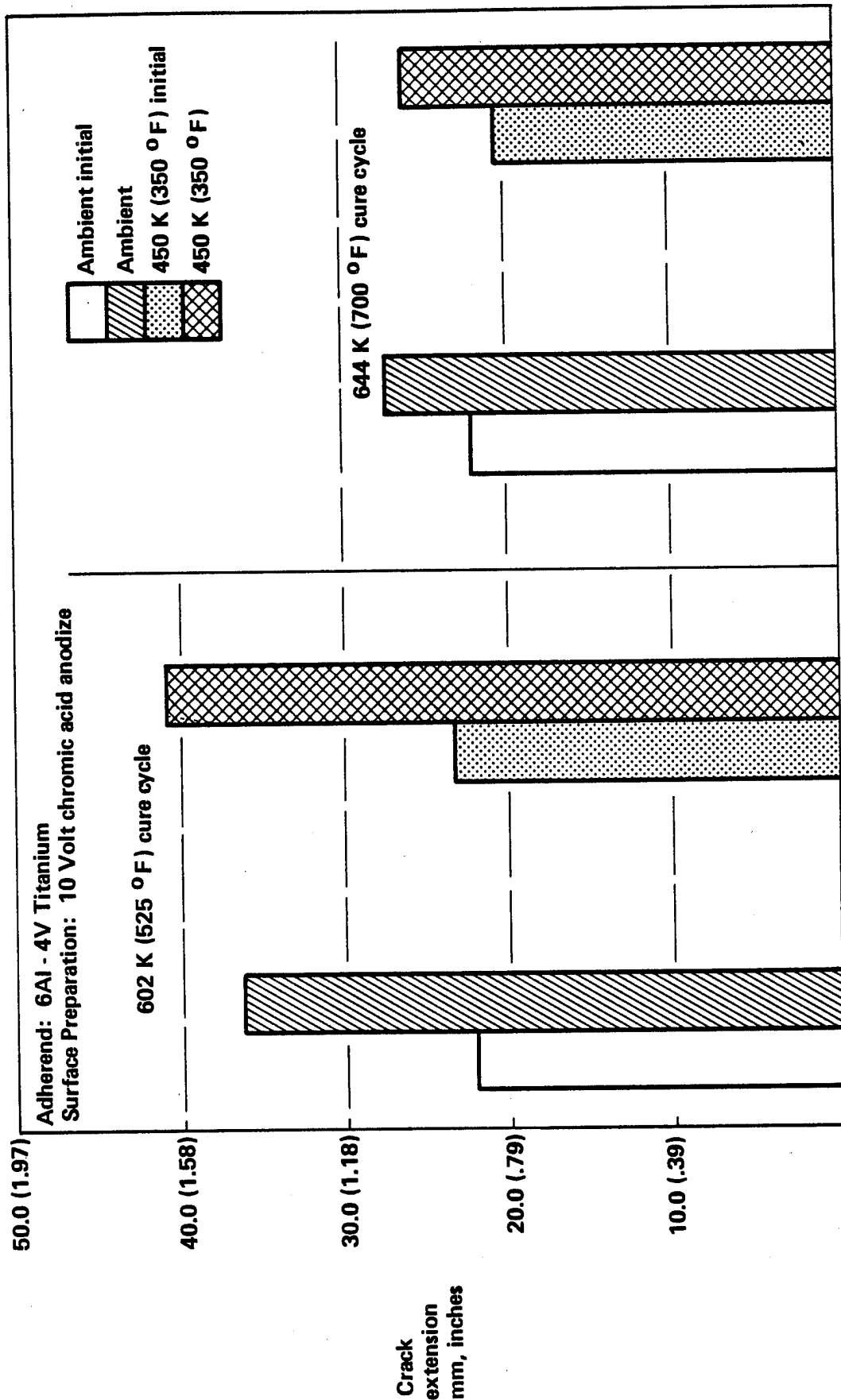

**FIGURE 2.4.10.**  
**CRACK EXTENSION AFTER HUMIDITY EXPOSURE (1000 HOURS)**  
**322 K (120° F)/95% RELATIVE HUMIDITY (PPQ-HC)**

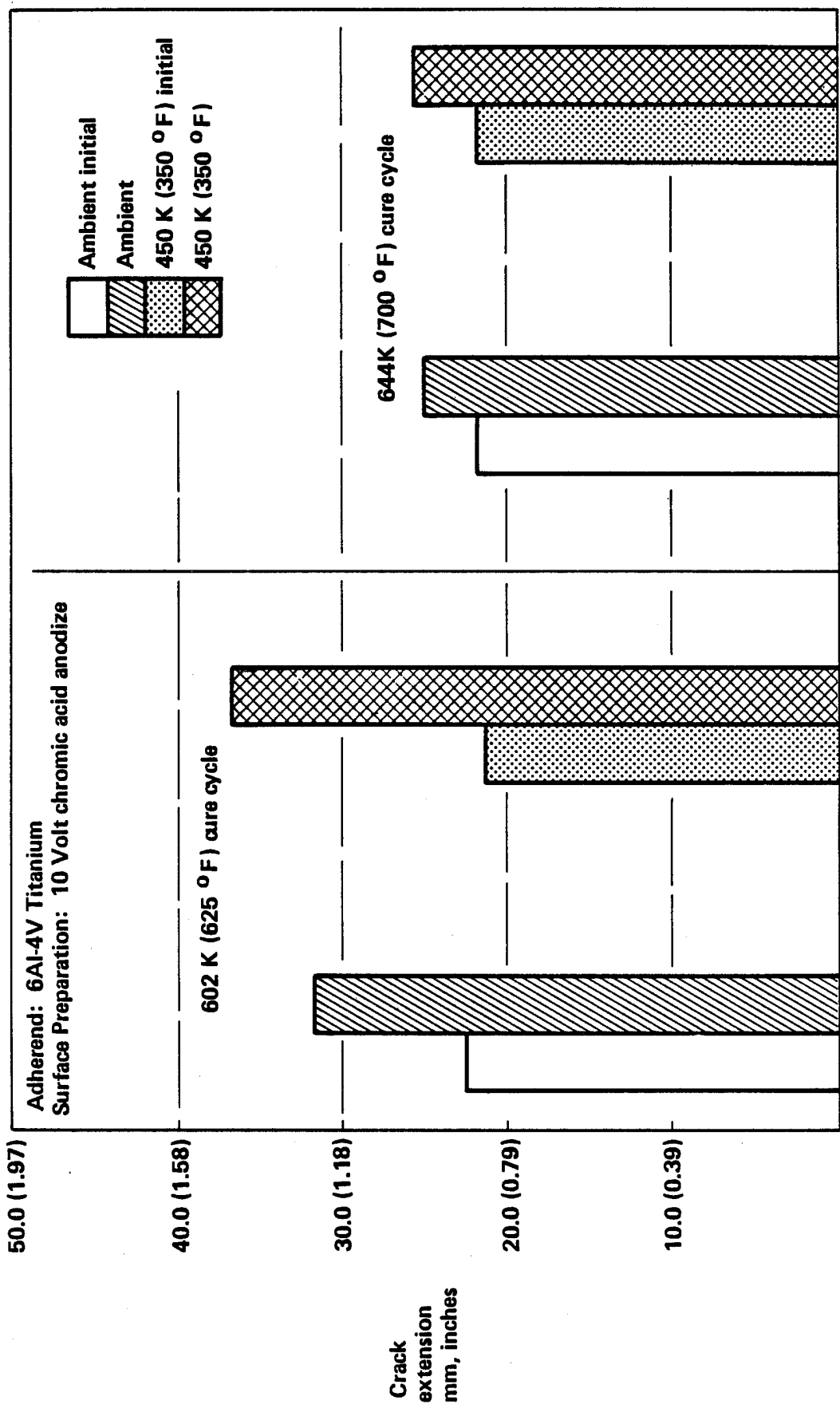

**FIGURE 2.4.11.**  
**CRACK EXTENSION VS EXPOSURE TIME AT 505 K (450° F)**

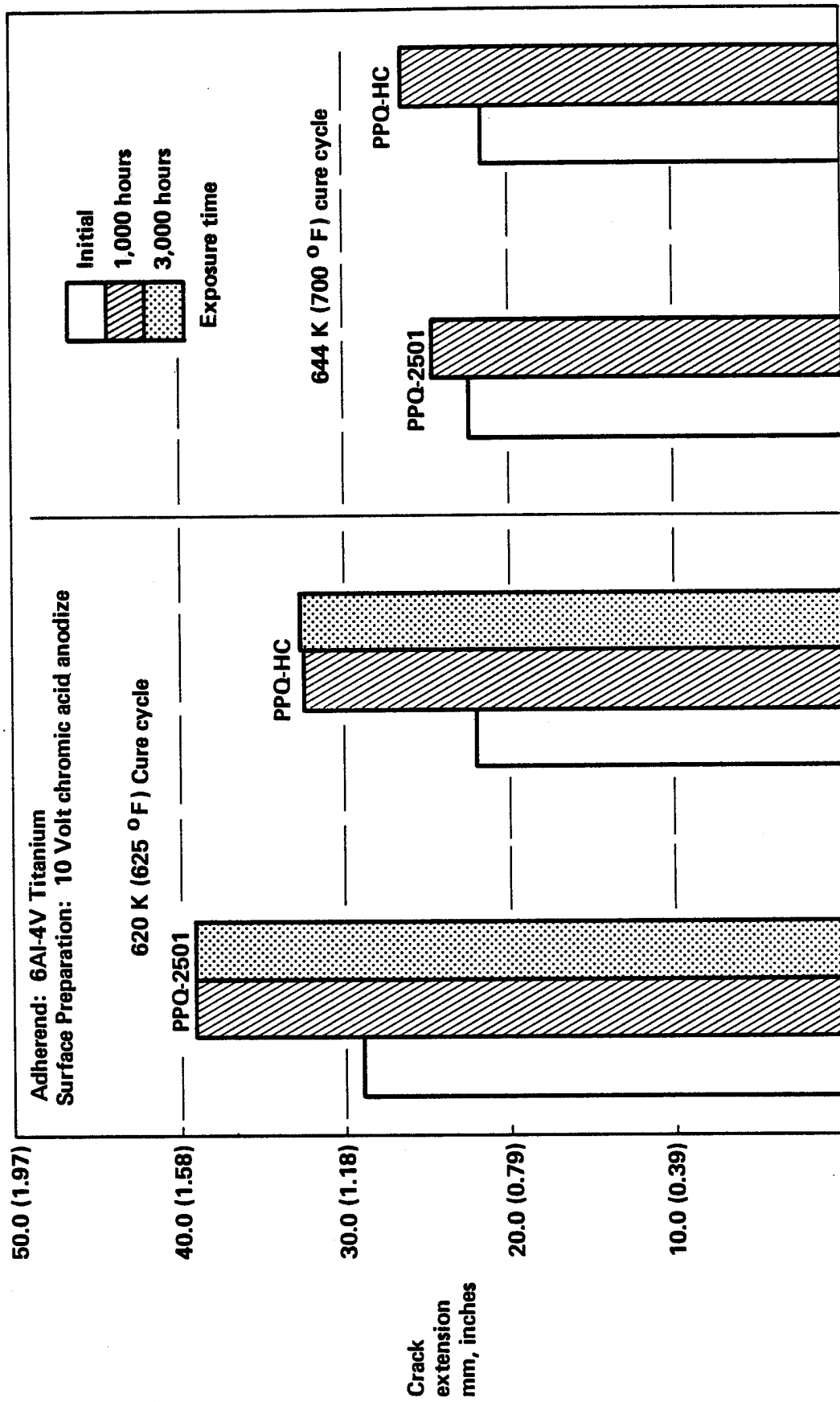

## 644K (700°F) Cure Cycle

No climbing drum peel test specimens were fabricated using the 644K (700°F) cure cycle.

### 3.0 CONCLUSIONS AND RECOMMENDATIONS

#### 3.1 Conclusions

The single most critical aspect of this investigation is the impact of the cure temperature upon PPQ response to environmental exposure. The 602K (625°F) cure cycle was selected as a compromise to promote improved thermal stability of the bond between PPQ and the titanium oxide surface, and as a common cure cycle for the selected adhesive systems in Phase II. Previous work in Phase I and II demonstrated a time-temperature relationship in bond stability, possibly due to the penetration/chemical interaction of the M-cresol/xylene solvent and the oxide-metal interface causing separation which resulted in bond failure. Cure cycles in the 672K (750°F) range caused almost immediate adhesive bond failures.

It is clear that the 602K (625°F) cure cycle, while possibly increasing the oxide to adhesive thermal stability, contributed to the poor environmental stability of the bond. Since initial bond strengths using this cure cycle were (in general) good, the decision to proceed with it seemed appropriate. However, it was not until the results of long term exposure were being established that it became apparent that the optimum adhesive properties had not been attained. Additional work indicated that 644K (700°F) cured test specimens exhibited better shear and toughness properties especially after environmental exposure (Skydrol, humidity) and 505K (450°F) exposure (3000 hours).

All adhesives as supplied were easily converted into film form and fabricated into test specimens using normal processing techniques.

X-PQ (processed at 602K (625°F)), exhibited good initial adhesive properties to 505K (450°F), including long term aging (1000 hours) in stressed Skydrol exposure. X-PQ also retained a majority of its initial shear strength after humidity exposure (1000 hours), although the fracture toughness decreased. A significant degradation in shear strength (stressed/unstressed) and toughness was also noted during 505K (450°F) exposure.

PPQ-2501 displayed good initial adhesive properties to 450K (350°F) at both process conditions used. However, the 644K (700°F) cured test specimens exhibited superior shear and toughness properties at all initial conditions compared to the 602K (625°F) cured test specimens. A significant improvement in shear properties was also apparent in the 644K (700°F) cured test specimens after stressed 505K (450°F) and Skydrol exposure. Previous test specimens cured at 602K (625°F) failed after 120 hour exposure at these conditions. The 644K (700°F) cured test specimens retained a greater percentage of their initial properties after environmental and 505K (450°F) exposure in contrast to the 602K (625°F) cured adhesives.

PPQ-HC also displayed good adhesive properties to 450K (350°F) at both process conditions used. The 644K (700°F) cure test specimens exhibited superior shear and toughness properties at all initial conditions compared to the 602K (625°F) cured test specimens. A significant improvement in crack extension properties was also noted after humidity exposure for the 644K (700°F) cured system. Additional improvements in Skydrol resistance and creep resistance at 505K (450°F) was also realized using the 644K (700°F) cure cycle.

In general, the adhesive candidates exhibited good shear and toughness properties from 219K (-67°F) to 450K (350°F). At 505K (450°F), the 602K (625°F) cured adhesives shear strength and toughness degraded quickly, in contrast to the 644K (700°F) cured adhesives. These polymers were only slightly affected by humidity exposure at both process conditions used. The 644K (700°F) cured polymers displayed superior shear properties after stressed Skydrol and 505K (450°F) exposure.

### **3.2 Recommendations**

Further optimization and development of the adhesive systems, if continued, should include investigation of surface preparation and post-curing methods. Additional investigation of alternative surface preparation techniques to improve high temperature bond stability is also required. The effect of post-curing the PPQ adhesives also requires more work, specifically to characterize the relationship between post cure and initial strength and strength retention at elevated temperatures.

#### 4.0 REFERENCES

1. S. G. Hill, P. D. Peters, and C. L. Hendricks, "Evaluation of High Temperature Structural Adhesives for Extended Service," NASA Contractor Report 165944, July 1982.
2. P. M. Hergenrother, "Polyphenylquinoxaline Containing Pendent Phenylethynyl Groups: Preliminary Mechanical Properties", *Journal of Applied Polymer Science*, 28, 355 (1983).

## 5.0 APPENDICES

TABLE 5.0.1

X-PQ ROOM TEMPERATURE EXPOSURE INDIVIDUAL TEST VALUES  
602K (625°F) CURE CYCLE

Test	Test Temperature K (°F)									
	Ambient	% C	219 (-67)	% C	450 (350)	% C	505 (450)	% C		
Lap Shear, MPa (psi)	26.2 (3800)	90	30.8 (4460)	-	25.9 (3750)	95	18.6 (2700)	95		
	26.3 (3814)	—	29.3 (4250)	95	25.5 (3700)	90	14.9 (2160)	90		
	25.0 (3620)	90	28.0 (4060)	60	23.1 (3350)	-	15.5 (2250)	95		
	27.6 (4000)	85	31.6 (4580)	70	25.9 (3750)	90	15.2 (2200)	95		
	27.6 (4000)	90	30.1 (4370)	60	27.3 (3950)	85	-	-		
Average	26.6 (3850)		29.9 (4340)		25.5 (3700)		16.1 (2330)			
Crack Extension, mm (inches)	22.4 (0.88)				26.0 (1.02)		24.9 (0.98)			
	22.6 (0.89)				21.6 (0.85)		24.4 (0.96)			
	20.6 (0.81)				22.4 (0.88)		24.1 (0.95)			
	23.4 (0.92)				25.1 (1.01)		25.4 (1.00)			
Average	22.1 (0.87)				23.9 (0.94)		24.6 (0.97)			
Drum Peel, N·M (in·lb)	1.0 (9.0)				7.1 (63.0)					
	1.8 (16.0)				4.6 (41.0)					
	1.1 (10.0)				5.1 (45.0)					
Average	1.31 (11.7)				5.6 (49.7)					

\* % C - Percent cohesive failure.

TABLE 5.0.2

X-PQ 1000 HOUR EXPOSURE, INDIVIDUAL TEST VALUES

602K (625°F) CURE CYCLE

Test	Test Temperature	Initial	322K (120°F)			Skydrol at Ambient		
			% C	95% R.H.	% C		% C	
Lap Shear, MPa (psi)	Ambient	26.2 (3800)	90	15.5 (2240)	60	29.7 (4300)	98	
		26.3 (3814)	—	14.4 (2080)	75	29.0 (4200)	95	
		25.0 (3620)	90	14.6 (2110)	50	26.8 (3880)	85	
		27.6 (4000)	85	17.5 (2540)	50	27.3 (3960)	95	
		27.6 (4000)	90	20.8 (3020)	60	28.4 (4120)	90	
	Avg.	26.6 (3850)		16.6 (2400)		28.2 (4090)		
	450K (350°F)	25.9 (3750)	95	17.0 (2470)	90	23.5 (3400)	95	
		25.5 (3700)	90	16.8 (2430)	85	24.3 (3520)	95	
		23.1 (3350)	—	18.6 (2700)	95	21.9 (3170)	90	
		25.9 (3750)	90	16.8 (2430)	95	26.0 (3770)	90	
		27.3 (3950)	85	18.7 (2710)	95	24.9 (3610)	95	
	Avg.	25.5 (3700)		17.6 (2550)		24.1 (3490)		
Drum Peel, N·M (in·lb)	Ambient	1.0 (9.0)	0.5 (4.0)					
		1.8 (16.0)	0.3 (2.5)					
		1.1 (10.0)	0.5 (4.0)					
	Avg.	1.3 (11.7)	0.4 (3.5)					

\* % C - Percent cohesive failure.

**TABLE 5.0.3**  
**X-PQ 3000 HOUR EXPOSURE, INDIVIDUAL TEST VALUES**  
**602K (625°F) CURE CYCLE**

Test	Test Temperature	Initial		Exposure Time (Hrs.)		Exposure Time (Hrs.)		Exposure Time (Hrs.)		% C
				% C	1000	% C	3000	% C		
Lap Shear MPa (psi)	450K (350°F)	25.9	(3750)	95	22.1	(3200)	95	20.8	(3020)	75
		25.5	(3700)	90	28.5	(4130)	90	21.8	(3160)	75
		23.1	(3350)	—	22.3	(3230)	85	17.2	(2500)	60
		25.9	(3750)	90	26.7	(3870)	85	25.5	(3700)	80
		27.3	(3950)	85	23.7	(3440)	80	17.2	(2500)	70
Avg.		25.5	(3700)		24.6	(3570)		20.6	(2980)	
	505K (450°F)	18.6	(2700)	95	17.4	(2520)	70	3.3	( 480)	5
		14.9	(2160)	90	16.0	(2320)	80	10.5	(1520)	50
		15.5	(2250)	95	10.1	(1460)	80	0.3	( 50)	0
		15.2	(2200)	95	9.8	(1420)	40	—	—	
					14.1	(2050)	40	—	—	
Avg.		16.1	(2330)		13.4	(1950)		4.7	( 680)	

\* % C - Percent cohesive failure

TABLE 5.0.4

## X-PQ CRACK EXTENSION INDIVIDUAL TEST VALUES

## 602K (625°F) CURE CYCLE

Exposure	Test Temperature	Exposure Time (hrs)						
		0	125	300	500	800	1000	3000
		mm (inches)	mm (inches)	mm (inches)	mm (inches)	mm (inches)	mm (inches)	mm (inches)
Ambient		22.2 (0.87)	24.1 (0.95)	24.4 (0.96)	24.4 (0.96)	24.4 (0.96)	24.4 (0.96)	—
		22.6 (0.89)	24.1 (0.95)	24.4 (0.96)	24.4 (0.96)	24.4 (0.96)	24.4 (0.96)	—
		20.6 (0.81)	22.6 (0.89)	22.9 (0.90)	22.9 (0.90)	22.9 (0.90)	22.9 (0.90)	—
		23.4 (0.92)	25.1 (0.99)	25.1 (0.99)	25.1 (0.99)	25.1 (0.99)	25.1 (2.51)	—
	Average	22.1 (0.87)	23.9 (0.94)	24.1 (0.95)	24.1 (0.95)	24.1 (0.95)	24.1 (0.95)	—
450K (350°F)		26.0 (1.02)	26.2 (1.03)	26.2 (1.03)	26.2 (1.03)	26.2 (1.03)	27.8 (1.09)	27.8 (1.09)
		21.6 (0.85)	22.9 (0.90)	22.9 (0.90)	22.9 (0.90)	23.4 (0.92)	23.4 (0.92)	24.4 (0.96)
		22.2 (0.87)	25.0 (0.98)	25.0 (0.98)	25.0 (0.98)	25.9 (1.02)	25.9 (1.02)	25.9 (1.02)
		25.6 (1.01)	25.6 (1.01)	25.6 (1.01)	25.6 (1.01)	25.8 (1.01)	25.8 (1.01)	26.2 (1.03)
	Average	23.9 (0.94)	24.9 (0.98)	24.9 (0.98)	24.9 (0.98)	25.4 (1.00)	25.7 (1.01)	25.9 (1.02)
505K (450°F)		25.0 (0.98)	27.2 (1.07)	28.2 (1.11)	28.2 (1.11)	28.2 (1.11)	28.2 (1.11)	41.4 (1.63)
		24.3 (0.96)	26.2 (1.03)	26.9 (1.06)	26.9 (1.06)	26.9 (1.06)	26.9 (1.06)	45.5 (1.79)
		24.1 (0.95)	28.2 (1.11)	28.2 (1.11)	28.2 (1.11)	28.2 (1.11)	28.2 (1.11)	50.0 (1.97)
		25.4 (1.00)	27.4 (1.08)	29.0 (1.14)	29.0 (1.14)	29.0 (1.14)	29.0 (1.14)	39.6 (1.56)
	Average	24.6 (0.97)	27.3 (1.07)	28.1 (1.11)	28.1 (1.11)	28.1 (1.11)	28.1 (1.11)	44.2 (1.74)
322K (120°F)/ 95% R.H.		22.0 (0.86)	27.9 (1.09)	32.3 (1.27)	33.8 (1.33)	34.5 (1.36)	35.8 (1.41)	—
		21.8 (0.86)	25.1 (0.99)	26.9 (1.06)	27.4 (1.08)	32.5 (1.28)	33.8 (1.33)	—
		21.6 (0.85)	30.5 (1.20)	32.0 (1.26)	33.0 (1.30)	33.0 (1.30)	33.5 (1.32)	—
		21.8 (0.86)	30.2 (1.19)	31.8 (1.25)	34.5 (1.36)	35.1 (1.38)	35.8 (1.41)	—
	Average	21.8 (0.86)	28.4 (1.12)	30.7 (1.21)	32.6 (1.27)	33.8 (1.33)	34.8 (1.37)	—
450K (350°F)		24.4 (0.96)	56.4 (2.22)	56.4 (2.22)	73.4 (2.89)	79.8 (3.14)	82.0 (3.23)	—
		21.8 (0.86)	42.9 (1.69)	42.9 (1.69)	43.9 (1.73)	46.5 (1.83)	46.5 (1.83)	—
		30.2 (1.19)	50.8 (2.00)	50.8 (2.00)	60.7 (2.39)	62.2 (2.45)	62.2 (2.45)	—
		24.9 (0.98)	75.4 (2.97)	75.4 (2.97)	76.2 (3.00)	76.2 (3.00)	76.2 (3.00)	—
	Average	25.3 (1.00)	56.4 (2.22)	56.4 (2.22)	63.6 (2.50)	66.2 (2.60)	66.8 (2.63)	—

TABLE 5.0.5

PPQ-2501 ROOM TEMPERATURE EXPOSURE INDIVIDUAL TEST VALUES

602K (625°F) CURE CYCLE

Test	Test Temperature K (°F)											
	Ambient	% C	219 (-67)	% C	450 (350)	% C	505 (450)	% C				
Lap Shear, MPa (psi)	21.4 (3100)	60	26.5 (3840)	35	21.0 (3050)	40	7.9 (1150)	65				
	22.1 (3200)	70	23.8 (3450)	40	20.9 (2900)	45	7.6 (1100)	85				
	22.1 (3200)	80	25.2 (3660)	25	17.6 (2550)	50	6.4 (930)	90				
	19.0 (2750)	20	24.8 (3600)	15	19.0 (2750)	50	10.7 (1550)	60				
	21.0 (3050)	15	25.5 (3700)	20	22.4 (3250)	50	7.9 (1150)	90				
Average	21.1 (3060)		25.2 (3650)		20.0 (2900)		8.1 (1180)					
Crack Extension, mm (inches)	23.1 (0.91)				24.1 (0.95)		32.5 (1.28)					
	25.4 (1.00)				31.8 (1.25)		21.8 (0.86)					
	21.8 (0.86)				26.4 (1.04)		35.3 (1.39)					
	20.8 (0.82)				19.3 (0.76)		25.9 (1.02)					
Average	22.8 (0.90)				25.4 (1.00)		29.0 (1.14)					
Drum Peel, N·M (in·lb)	0.7 (6.3)				0.4 (3.4)							
	0.5 (4.1)				0.2 (1.9)							
	0.6 (4.9)				0.1 (0.7)							
Average	0.6 (5.1)				0.2 (2.0)							

\* % C - Percent cohesive failure.

TABLE 5.0.6

PPQ-2501 1000 HOUR EXPOSURE, INDIVIDUAL TEST VALUES

602K (625°F) CURE CYCLE

Test	Test Temperature	Initial	322K (120°F)			% C	Skydrol at Ambient	% C
			% C	95% R.H.	% C			
Lap Shear, MPa (psi)	Ambient	21.4 (3100)	60	14.9 (2160)	15	All specimens failed at 120 hours	10	
		22.1 (3200)	70	17.0 (2460)	20		5	
		22.1 (3200)	80	17.7 (2570)	30		10	
		19.0 (2750)	20	18.3 (2660)	40		5	
		21.0 (3050)	15	16.7 (2420)	40		5	
Avg.		21.1 (3060)		16.9 (2450)				
	450K (350°F)	21.0 (3050)	40	14.2 (2056)	90	All specimens failed at 120 hours	5	
		20.9 (2900)	45	15.2 (2200)	70		5	
		17.6 (2550)	50	13.5 (1956)	90		0	
		19.0 (2750)	50	16.3 (2360)	60		5	
		22.4 (3250)	50	17.4 (2518)	50		5	
Avg.		20.0 (2900)		15.3 (2220)				
Drum Peel, N·M (in·lb)	Ambient	0.7 ( 6.3)		0.6 (5.1)				
		0.5 ( 4.1)		0.2 (2.2)				
		0.6 ( 4.9)		0.3 (2.3)				
Avg.		0.6 ( 5.1)		0.4 (3.2)				

\* % C - Percent cohesive failure.

**TABLE 5.0.7**

**PPQ-2501 3000 HOUR EXPOSURE, INDIVIDUAL TEST VALUES  
602K (625°F) CURE CYCLE**

Test	Test Temperature	Initial		% C		Exposure Time (Hrs.)		3000		% C	
		1000	% C	1000	% C	3000	% C	3000	% C		
Lap Shear MPa (psi)	450K (350°F)	21.0	(3050)	40	20.7	(3000)	100	20.8	(3020)	90	
		20.9	(2900)	45	17.9	(2590)	100	20.3	(2940)	100	
		17.6	(2550)	50	24.0	(3480)	100	22.1	(3200)	100	
		19.0	(2750)	50	21.7	(3150)	100	27.6	(4000)	100	
		22.4	(3250)	50	22.0	(3190)	100	29.7	(4300)	90	
		Avg.		20.0	(2900)		21.2	(3080)		24.1	(3490)
	505K (450°F)	7.9	(1150)	65	11.4	(1650)	80	13.1	(1900)	40	
		7.6	(1100)	85	15.3	(2220)	80	12.1	(1760)	50	
		6.4	( 930)	90	16.7	(2420)	75	17.4	(2520)	60	
		10.7	(1550)	60	14.3	(2080)	60	11.9	(1720)	50	
		7.9	(1150)	90	20.1	(2910)	70	12.8	(1850)	50	
		Avg.		8.1	(1180)		15.6	(2260)		13.4	(1950)

TABLE 5.0.8

## PPQ-2501 CRACK EXTENSION INDIVIDUAL TEST VALUES

## 602K (6250F) CURE CYCLE

Exposure	Test Temperature	Exposure Time (hrs)						
		0	125	264	500	750	1000	3000
		mm (inches)	mm (inches)	mm (inches)	mm (inches)	mm (inches)	mm (inches)	mm (inches)
Ambient	Ambient	23.1 (0.91)	27.7 (1.09)	28.7 (1.13)	28.7 (1.13)	28.7 (1.13)	31.8 (1.25)	—
		25.4 (1.00)	29.5 (1.16)	30.0 (1.18)	30.2 (1.19)	30.2 (1.19)	30.2 (1.19)	—
		21.8 (0.86)	25.4 (1.00)	25.4 (1.00)	25.9 (1.02)	25.9 (1.02)	25.9 (1.02)	—
		20.8 (0.82)	22.1 (0.87)	24.6 (0.97)	24.6 (0.97)	24.6 (0.97)	24.6 (0.97)	—
	Average	22.8 (0.90)	26.2 (1.03)	27.2 (1.07)	27.4 (1.08)	27.4 (1.08)	28.1 (1.11)	—
450K (3500F)	450K (3500F)	24.1 (0.95)	30.2 (1.19)	31.2 (1.23)	31.2 (1.23)	31.2 (1.23)	31.2 (1.23)	31.2 (1.23)
		31.8 (1.25)	33.3 (1.31)	34.0 (1.34)	34.0 (1.34)	34.0 (1.34)	35.1 (1.38)	35.1 (1.38)
		26.4 (1.04)	30.0 (1.18)	30.0 (1.18)	30.5 (1.20)	30.5 (1.23)	32.0 (1.26)	32.0 (1.26)
		19.3 (0.76)	22.6 (0.89)	23.1 (0.91)	23.1 (0.91)	23.1 (0.91)	23.9 (0.94)	23.9 (0.94)
	Average	25.4 (1.00)	29.1 (1.14)	29.6 (1.17)	29.6 (1.17)	29.9 (1.18)	30.5 (1.20)	30.5 (1.20)
505K (4500F)	505K (4500F)	32.5 (1.28)	36.8 (1.45)	37.6 (1.48)	37.6 (1.48)	47.0 (1.85)	47.5 (1.87)	47.5 (1.87)
		21.8 (0.86)	23.4 (0.92)	24.9 (0.98)	25.4 (1.00)	28.5 (1.12)	33.5 (1.32)	33.5 (1.32)
		35.3 (1.39)	38.1 (1.50)	38.1 (1.50)	39.1 (1.54)	42.4 (1.67)	42.4 (1.67)	42.4 (1.67)
		25.9 (1.02)	28.4 (1.12)	29.2 (1.15)	29.7 (1.17)	31.8 (1.25)	32.5 (1.28)	32.5 (1.28)
	Average	29.0 (1.14)	31.8 (1.25)	32.4 (1.28)	33.0 (1.30)	37.4 (1.47)	39.1 (1.54)	39.1 (1.54)
322K (1200F)/ 95% R.H.	Ambient	27.4 (1.08)	33.5 (1.32)	34.5 (1.36)	35.6 (1.40)	36.6 (1.44)	37.6 (1.48)	—
		20.6 (0.81)	37.8 (1.49)	37.8 (1.49)	38.1 (1.50)	38.1 (1.50)	38.1 (1.50)	—
		20.6 (0.81)	26.2 (1.03)	26.9 (1.06)	27.4 (1.08)	29.0 (1.14)	30.7 (1.21)	—
		21.1 (0.83)	33.5 (1.32)	37.1 (1.46)	37.1 (1.46)	37.8 (1.49)	39.4 (1.55)	—
	Average	22.4 (0.88)	32.8 (1.29)	34.1 (1.34)	34.5 (1.36)	35.4 (1.39)	36.6 (1.44)	—
322K (1200F)/ 95% R.H.	450K (3500F)	22.6 (0.89)	—	—	39.9 (1.57)	—	57.7 (2.27)	—
		20.6 (0.81)	—	—	32.0 (1.26)	—	32.0 (1.26)	—
		25.7 (1.01)	—	—	34.3 (1.35)	—	41.1 (1.62)	—
		25.9 (1.02)	—	—	33.0 (1.30)	—	33.0 (1.30)	—
	Average	23.6 (0.93)	—	—	34.8 (1.37)	—	40.9 (1.61)	—

TABLE 5.0.9

PPQ-HC ROOM TEMPERATURE EXPOSURE INDIVIDUAL TEST VALUES

602K (625°F) CURE CYCLE

Test	Test Temperature K (°F)									
	Ambient	% C	219 (-67)	% C	450 (350)	% C	505 (450)	% C		
Lap Shear, MPa (psi)	22.6 (3270)	50	24.7 (3580)	50	17.2 (2500)	40	14.1 (2050)	50		
	19.3 (2800)	30	17.4 (2530)	60	18.3 (2650)	50	15.5 (2250)	50		
	22.8 (3300)	50	17.9 (2590)	50	21.3 (3050)	60	7.6 (1100)	35		
	20.3 (2950)	50	32.2 (4670)	60	21.7 (3150)	70	12.8 (1850)	50		
	29.0 (4200)	50	33.4 (4850)	70	19.0 (2750)	70	11.7 (1700)	40		
Average	22.8 (3300)		25.1 (3640)		19.4 (2820)		12.3 (1790)			
Crack Extension, mm (inches)	22.9 (0.90)				22.6 (0.89)		21.8 (0.86)			
	21.8 (0.86)				20.8 (0.82)		19.8 (0.78)			
	23.1 (0.91)				21.3 (0.84)		22.1 (0.87)			
	19.8 (0.78)				27.4 (1.08)		24.6 (0.97)			
Average	21.8 (0.86)				23.1 (0.91)		22.1 (0.87)			
Drum Peel, N·M (in·lb)	1.1 (9.6)				2.0 (17.4)					
	1.3 (11.6)				1.8 (16.2)					
	1.8 (16.3)				2.0 (17.3)					
Average	1.4 (12.5)				1.9 (17.0)					

\* % C - Percent cohesive failure.

TABLE 5.0.10

PPQ-HC 1000 HOUR EXPOSURE, INDIVIDUAL TEST VALUES

602K (625°F) CURE CYCLE

Test	Test Temperature	Initial	322K (120°F)			Skydrol at Ambient		
			% C	95% R.H.	% C		% C	
Lap Shear, MPa (psi)	Ambient	22.6 (3270)	50	23.4 (3390)	75	9.2 (1330)	15	
		19.3 (2800)	30	22.8 (3300)	60	9.8 (1424)	5	
		22.8 (3300)	50	21.9 (3180)	60	7.7 (1120)	5	
		20.3 (2950)	50	21.4 (3100)	60	22.6 (3280)	50	
		29.0 (4200)	50	20.0 (2900)	50	14.9 (2160)	10	
Avg.		22.8 (3300)		21.9 (3170)		12.8 (1860)		
	450K (350°F)	17.2 (2500)	40	5.9 (860)	20	2.1 (300)	0	
		18.3 (2650)	50	9.3 (1350)	25	1.1 (156)	0	
		21.3 (3050)	60	10.9 (1584)	30	1.2 (170)	0	
		21.7 (3150)	70	10.8 (1560)	20	Premature Failure	0	
		19.0 (2750)	70	7.2 (1038)	15	Premature Failure	0	
Avg.		19.4 (2820)		8.8 (1280)		1.4 (210)		
Drum Peel, N·M (in·lb)	Ambient	1.1 (9.6)		2.5 (22.3)				
		1.3 (11.6)		0.7 (6.5)				
		1.8 (16.3)		2.4 (21.1)				
Avg.		1.4 (12.5)		1.9 (16.6)				

\* % C - Percent cohesive failure.

TABLE 5.0.11

PPQ-HC 3000 HOUR EXPOSURE, INDIVIDUAL TEST VALUES

602K (625°F) CURE CYCLE

Test	Test Temperature	Initial		% C		Exposure Time (Hrs.)		3000		% C	
		Initial	% C	1000	% C	3000	% C	3000	% C		
Lap Shear MPa (psi)	450K (350°F)	17.2	(2500)	40	30.0	(4350)	95	19.4	(2820)	90	
		18.3	(2650)	50	27.1	(3930)	95	25.5	(3700)	100	
		21.3	(3050)	60	29.7	(4300)	90	26.9	(3900)	100	
		21.7	(3150)	70	30.7	(4450)	95	27.9	(4050)	100	
		19.0	(2750)	70	30.9	(4480)	95	26.9	(3900)	100	
Avg.		19.4	(2820)		29.7	(4300)		25.3	(3670)		
	505K (450°F)	14.1	(2050)	50	14.8	(2140)	50	12.7	(1840)	60	
		15.5	(2250)	50	12.8	(1860)	50	15.0	(2180)	50	
		7.6	(1100)	35	12.7	(1840)	60	13.7	(1980)	60	
		12.8	(1850)	50	16.8	(2440)	60	15.4	(2240)	60	
		11.7	(1700)	40	12.6	(1820)	70	15.8	(2290)	75	
Avg.		12.3	(1790)		13.9	(2020)		14.6	(2110)		

TABLE 5.0.12

## PPQ-HC CRACK EXTENSION INDIVIDUAL TEST VALUES

## 602K (6250F) CURE CYCLE

Exposure	Test Temperature	Exposure Time (hrs)						
		0	125	250	500	750	1000	3000
		mm (inches)	mm (inches)	mm (inches)	mm (inches)	mm (inches)	mm (inches)	mm (inches)
Ambient		22.9 (0.90)	26.9 (1.06)	28.5 (1.12)	28.5 (1.12)	28.5 (1.12)	28.4 (1.12)	—
		21.8 (0.86)	24.4 (0.96)	24.4 (0.96)	25.1 (0.99)	25.1 (0.99)	25.1 (0.99)	—
		23.1 (0.91)	25.6 (1.01)	26.2 (1.03)	26.2 (1.03)	26.2 (1.03)	26.2 (1.03)	—
		19.8 (0.78)	20.8 (0.82)	23.7 (0.92)	23.7 (0.92)	23.7 (0.92)	24.6 (0.97)	—
Average		21.8 (0.86)	24.4 (0.96)	25.7 (1.01)	25.9 (1.02)	25.9 (1.02)	26.1 (1.03)	—
450K (3500F)		22.6 (0.89)	25.1 (0.99)	25.1 (0.99)	25.7 (1.01)	25.7 (1.01)	26.2 (1.03)	26.2 (1.03)
		20.8 (0.82)	23.1 (0.91)	23.4 (0.92)	23.4 (0.92)	23.4 (0.92)	24.6 (0.97)	24.6 (0.97)
		21.3 (0.84)	23.4 (0.92)	23.6 (0.93)	23.6 (0.93)	23.6 (0.93)	24.4 (0.96)	26.9 (1.06)
		27.4 (1.08)	34.0 (1.34)	34.0 (1.34)	34.0 (1.34)	34.0 (1.34)	34.0 (1.34)	48.3 (1.90)
Average		23.1 (0.91)	26.4 (1.04)	26.4 (1.04)	26.5 (1.05)	26.7 (1.05)	27.4 (1.08)	31.5 (1.24)
505K (4500F)		21.8 (0.86)	24.1 (0.95)	24.4 (0.96)	24.4 (0.96)	24.4 (0.96)	24.4 (0.96)	24.9 (0.98)
		19.8 (0.78)	21.1 (0.83)	23.6 (0.93)	24.9 (0.96)	31.2 (1.23)	31.2 (1.23)	31.2 (1.23)
		22.1 (0.87)	24.4 (0.96)	24.9 (0.98)	25.9 (1.02)	25.9 (1.02)	32.3 (1.27)	32.3 (1.27)
		24.6 (0.97)	35.1 (1.38)	35.1 (1.38)	36.3 (1.43)	37.3 (1.47)	42.2 (1.66)	42.2 (1.66)
Average		22.1 (0.87)	26.2 (1.03)	27.0 (1.06)	27.7 (1.09)	28.2 (1.11)	32.5 (1.28)	32.6 (1.29)
322K (1200F)/ 95% R.H.		24.9 (0.98)	31.8 (1.25)	32.8 (1.29)	34.0 (1.34)	34.0 (1.34)	35.3 (1.39)	—
		21.8 (0.86)	26.7 (1.05)	28.6 (1.12)	28.7 (1.13)	29.7 (1.17)	31.0 (1.22)	—
		22.4 (0.88)	26.7 (1.05)	27.2 (1.07)	27.4 (1.08)	29.0 (1.14)	29.0 (1.14)	—
		21.1 (0.83)	28.2 (1.11)	29.7 (1.17)	30.7 (1.21)	31.2 (1.23)	31.8 (1.25)	—
Average		22.5 (0.89)	28.5 (1.12)	29.5 (1.16)	30.2 (1.19)	31.0 (1.22)	31.8 (1.25)	—
322K (1200F)/ 95% R.H.		21.8 (0.86)	—	—	29.7 (1.17)	—	46.5 (1.83)	—
		19.8 (0.78)	—	—	31.5 (1.24)	—	32.8 (1.29)	—
		22.4 (0.88)	—	—	30.5 (1.20)	—	31.8 (1.25)	—
		20.8 (0.82)	—	—	30.2 (1.19)	—	36.1 (1.42)	—
Average		21.3 (0.84)	—	—	30.5 (1.20)	—	36.8 (1.45)	—

TABLE 5.0.13

PPQ-2501 ROOM TEMPERATURE EXPOSURE INDIVIDUAL TEST VALUES

644K (700°F) CURE CYCLE

Test	Test Temperature K (°F)								
	Ambient	% C	450	(350)	% C	505	(450)	% C	
Lap Shear, MPa (psi)	28.8	(4180)	80	32.5	(4710)	75	24.8	(3600)	75
	29.4	(4270)	75	33.4	(4850)	90	26.6	(3850)	80
	29.0	(4200)	60	31.0	(4490)	80	23.0	(3340)	65
	25.9	(3760)	50	28.4	(4120)	90	21.4	(3100)	75
	26.9	(3900)	90	34.1	(4950)	90	23.4	(3400)	80
Average	28.0	(4060)		31.9	(4620)		23.9	(3460)	
Crack Extension, mm (inches)	21.1	(0.83)							
	22.6	(0.89)							
	21.8	(0.86)							
	24.4	(0.96)							
Average	22.4	(0.88)							

\* % C - Percent cohesive failure.

TABLE 5.0.14

PPQ-2501 1000 HOUR EXPOSURE, INDIVIDUAL TEST VALUES

644K (700°F) CURE CYCLE

Test	Test Temperature	Initial	322K (120°F)		% C	Skydrol at Ambient		% C
			% C	95% R.H.				
Lap Shear, MPa (psi)	Ambient	28.8 (4180)	80	25.2 (3660)	100	24.2 (3510)	60	
		29.4 (4270)	75	25.0 (3620)	95	27.6 (4000)	90	
		29.0 (4200)	60	25.7 (3730)	90	25.7 (3720)	80	
		25.9 (3760)	50	25.7 (3720)	85	27.7 (4020)	90	
		26.9 (3900)	90	27.2 (3940)	85	26.5 (3840)	80	
Avg.		28.0 (4060)		25.7 (3730)		26.3 (3820)		
	450K (350°F)	32.5 (4710)	75			25.7 (3720)	75	
		33.4 (4850)	90			25.7 (3720)	95	
		31.0 (4490)	80			21.3 (3090)	80	
		28.4 (4120)	90			22.0 (3190)	90	
		34.1 (4950)	90			20.1 (2920)	80	
Avg.		31.9 (4620)				21.9 (3170)		

\* % C - Percent cohesive failure

TABLE 5.0.15

## PPQ-2501 CRACK EXTENSION INDIVIDUAL TEST VALUES

## 644K (700°F) CURE CYCLE

Exposure	Test Temperature	Exposure Time (hrs)					
		0	500	750	1000	2000	3000
		mm (inches)	mm (inches)	mm (inches)	mm (inches)	mm (inches)	mm (inches)
505K (450°F)	505K (450°F)	21.1 (0.83)	23.6 (0.93)	23.6 (0.93)	23.6 (0.93)		
		22.6 (0.89)	25.1 (0.99)	25.1 (0.99)	25.7 (1.01)		
		21.8 (0.86)	23.1 (0.91)	23.1 (0.91)	23.1 (0.91)		
		24.4 (0.96)	25.9 (1.02)	25.9 (1.02)	25.9 (1.02)		
Average		24.4 (0.96)	24.4 (0.96)	24.6 (0.97)			
322K (120°F)/ 95% R.H.	Ambient	22.1 (0.87)	26.9 (1.06)	26.9 (1.06)	26.9 (1.06)		
		23.9 (0.94)	26.4 (1.04)	26.7 (1.05)	27.4 (1.08)		
		21.8 (0.86)	27.4 (1.08)	27.4 (1.08)	27.4 (1.08)		
		21.6 (0.85)	26.4 (1.04)	26.4 (1.04)	26.9 (1.06)		
Average		26.9 (1.06)	26.9 (1.06)	27.2 (1.07)			
322K (120°F)/ 95% R.H.	450K (350°F)	21.6 (0.85)	25.9 (1.02)	25.9 (1.02)	26.4 (1.04)		
		20.8 (0.82)	25.4 (1.00)	27.7 (1.09)	27.7 (1.09)		
		20.6 (0.81)	25.4 (1.00)	26.7 (1.05)	26.7 (1.05)		
		19.0 (0.75)	24.9 (0.98)	25.4 (1.00)	25.4 (1.00)		
Average		25.4 (1.00)	26.4 (1.04)	26.4 (1.04)			

TABLE 5.0.16

PPQ-HC ROOM TEMPERATURE EXPOSURE INDIVIDUAL TEST VALUES

644K (700°F) CURE CYCLE

Test	Test Temperature K (°F)					
	Ambient	% C	450 (350)	% C	505 (450)	% C
Lap Shear	30.7 (4450)	50	26.2 (3800)	95	25.2 (3650)	100
MPa (psi)	25.5 (3700)	25	26.3 (3820)	85	23.4 (3400)	95
	28.3 (4100)	30	29.9 (4340)	100	25.5 (3700)	90
	27.6 (4000)	40	29.0 (4200)	90	24.1 (3500)	100
	26.4 (3830)	40	29.5 (4280)	100	22.1 (3200)	100
Average	27.7 (4020)		28.2 (4090)		24.1 (3490)	
Crack Extension, mm (inches)	18.8 (0.74)					
	22.6 (0.89)					
	23.1 (0.91)					
	21.6 (0.85)					
Average	21.6 (0.85)					

\* % C - Percent cohesive failure.

TABLE 5.0.17

PPQ-HC 1000 HOUR EXPOSURE, INDIVIDUAL TEST VALUES

644K (700°F) CURE CYCLE

Test	Test Temperature	Initial	322K (120°F)			Skydrol at Ambient	
			% C	95% R.H.	% C		% C
Lap Shear, MPa (psi)	Ambient	30.7 (4450)	50	22.1 (3200)	40	22.4 (3250)	20
		25.5 (3700)	25	23.1 (3350)	70	24.8 (3600)	60
		28.3 (4100)	30	21.3 (3090)	50	23.4 (3400)	40
		27.6 (4000)	40	22.1 (3210)	60	22.8 (3300)	65
		26.4 (3830)	40	21.4 (3100)	60	23.4 (3390)	15
		Avg. 27.7 (4020)		22.0 (3190)		23.4 (3390)	
	450K (350°F)	26.2 (3800)	95			18.4 (2670)	100
		26.3 (3820)	85			17.7 (2560)	100
		29.9 (4340)	100			16.4 (2380)	95
		29.0 (4200)	90			15.9 (2310)	90
		29.5 (4280)	100			17.4 (2520)	100
		Avg. 28.2 (4090)				17.2 (2490)	

TABLE 5.0.18

## PPQ-HC CRACK EXTENSION INDIVIDUAL TEST VALUES

## 644K (700°F) CURE CYCLE

Exposure	Test Temperature	Exposure Time (hrs)					
		0	500	750	1000	2000	3000
		mm (inches)	mm (inches)	mm (inches)	mm (inches)	mm (inches)	mm (inches)
505K (450°F)	505K (450°F)	18.8 (0.74)	22.4 (0.88)	24.1 (0.95)	24.1 (0.95)	24.1 (0.95)	24.1 (0.95)
		22.6 (0.89)	24.6 (0.97)	24.6 (0.97)	24.6 (0.97)	24.6 (0.97)	24.6 (0.97)
		23.1 (0.91)	25.7 (1.01)	25.7 (1.01)	25.7 (1.01)	25.7 (1.01)	25.7 (1.01)
		21.6 (0.85)	23.4 (0.92)	23.4 (0.92)	23.4 (0.92)	23.4 (0.92)	23.4 (0.92)
Average		21.6 (0.85)	23.9 (0.94)	24.4 (0.96)	24.4 (0.96)	24.4 (0.96)	24.4 (0.96)
322K (120°F)/ 95% R.H.	Ambient	23.1 (0.91)	26.2 (1.03)	26.2 (1.03)	26.2 (1.03)	26.2 (1.03)	26.2 (1.03)
		21.1 (0.83)	24.1 (0.95)	24.1 (0.95)	24.1 (0.95)	24.1 (0.95)	24.1 (0.95)
		21.6 (0.85)	24.1 (0.95)	24.1 (0.95)	24.1 (0.95)	24.1 (0.95)	24.1 (0.95)
		21.6 (0.85)	26.2 (1.03)	26.2 (1.03)	26.2 (1.03)	26.2 (1.03)	26.2 (1.03)
Average		21.8 (0.86)	25.1 (0.99)	25.1 (0.99)	25.1 (0.99)	25.1 (0.99)	25.1 (0.99)
322K (120°F)/ 95% R.H.	450K (350°F)	24.1 (0.95)	26.2 (1.03)	26.2 (1.03)	26.2 (1.03)	27.2 (1.07)	27.2 (1.07)
		21.8 (0.86)	22.6 (0.89)	25.9 (1.02)	25.9 (1.02)	25.9 (1.02)	25.9 (1.02)
		20.1 (0.79)	21.3 (0.84)	22.6 (0.89)	24.6 (0.97)	24.6 (0.97)	24.6 (0.97)
		21.3 (0.84)	24.9 (0.98)	24.9 (0.98)	24.9 (0.98)	24.9 (0.98)	24.9 (0.98)
Average		21.8 (0.86)	23.9 (0.94)	24.9 (0.98)	24.9 (0.98)	25.7 (1.01)	25.7 (1.01)

1. Report No.	2. Government Accession No.	3. Recipient's Catalog No.	
4. Title and Subtitle Evaluation of High Temperature Structural Adhesives for Extended Service - Phase IV		5. Report Date October, 1985	6. Performing Organization Code
		8. Performing Organization Report No.	
7. Author(s) C. L. Hendricks, S. G. Hill, and J. N. Hale		10. Work Unit No.	
9. Performing Organization Name and Address Boeing Aerospace Company P. O. Box 3999 Seattle, Washington 98124		11. Contract or Grant No. NAS1-15605	
		13. Type of Report and Period Covered Contractor Report	
12. Sponsoring Agency Name and Address National Aeronautics and Space Administration Langley Research Center Washington, D. C. 20546		14. Sponsoring Agency Code	
		15. Supplementary Notes NASA Technical Representative - Mr. Paul M. Hergenrother Final Report	
16. Abstract <p>The evaluation of three phenylquinoxaline polymers as high temperature structural adhesives is presented. These included an experimental crosslinkable polymer (X-PQ) from NASA Langley and two experimental materials from King Mar Laboratories (PPQ-2501) and Hunt Chemical Corporation (PPQ-HC). Lap shear, crack extension, and climbing drum peel specimens were fabricated from all three polymers, and tested after thermal, combined thermal/humidity, and stressed Skydrol exposure.</p> <p>All three polymers generally performed well as adhesives at initial test temperatures from 219K (-67°F) to 505K (450°F) and after humidity exposure. The 644K (700°F) cured test specimens exhibited superior Skydrol resistance and thermal stability at 505K (450°F) when compared to the 602K (625°F) cured test specimens.</p>			
17. Key Words (Suggested by Author(s)) SuperSonic Cruise Research Adhesive Bonding PPQ Adhesives		18. Distribution Statement Unclassified - Unlimited	
19. Security Classif. (of this report) Unclassified	20. Security Classif. (of this page) Unclassified	21. No. of Pages 50	22. Price