

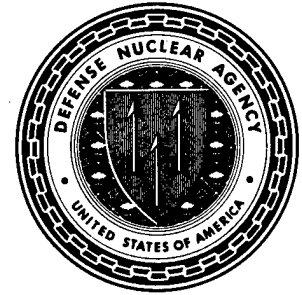

Defense Nuclear Agency  
Alexandria, VA 22310-3398



DNA-TR-95-21

## Batteryless Sensor for Intrusion Detection and Assessment of Threats

Gerald F. Ross, et al.  
ANRO Engineering Inc.  
450 Bedford Street  
Lexington, MA 02173

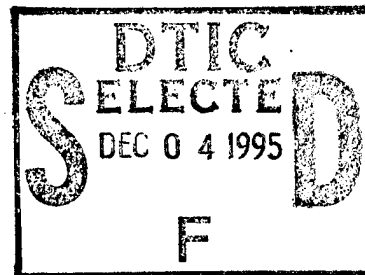

November 1995

Technical Report

CONTRACT No. DNA 001-94-C-0085

Approved for public release;  
distribution is unlimited.

19951130 049

DTIC QUALITY INSPECTED 5

**Destroy this report when it is no longer needed. Do not return to sender.**

**PLEASE NOTIFY THE DEFENSE NUCLEAR AGENCY,  
ATTN: CSTI, 6801 TELEGRAPH ROAD, ALEXANDRIA, VA  
22310-3398, IF YOUR ADDRESS IS INCORRECT, IF YOU  
WISH IT DELETED FROM THE DISTRIBUTION LIST, OR  
IF THE ADDRESSEE IS NO LONGER EMPLOYED BY YOUR  
ORGANIZATION.**



## DISTRIBUTION LIST UPDATE

This mailer is provided to enable DNA to maintain current distribution lists for reports. (We would appreciate your providing the requested information.)

- Add the individual listed to your distribution list.
- Delete the cited organization/individual.
- Change of address.

**NOTE:**  
Please return the mailing label from the document so that any additions, changes, corrections or deletions can be made easily. For distribution cancellation or more information call DNA/IMAS (703) 325-1036.

NAME: \_\_\_\_\_

ORGANIZATION: \_\_\_\_\_

**OLD ADDRESS**

**CURRENT ADDRESS**

\_\_\_\_\_  
\_\_\_\_\_  
\_\_\_\_\_

\_\_\_\_\_  
\_\_\_\_\_  
\_\_\_\_\_

TELEPHONE NUMBER: ( ) \_\_\_\_\_

**DNA PUBLICATION NUMBER/TITLE**

**CHANGES/DELETIONS/ADDITIONS, etc.)**  
*(Attach Sheet if more Space is Required)*

\_\_\_\_\_  
\_\_\_\_\_  
\_\_\_\_\_

\_\_\_\_\_  
\_\_\_\_\_  
\_\_\_\_\_

DNA OR OTHER GOVERNMENT CONTRACT NUMBER: \_\_\_\_\_

CERTIFICATION OF NEED-TO-KNOW BY GOVERNMENT SPONSOR (if other than DNA):

SPONSORING ORGANIZATION: \_\_\_\_\_

CONTRACTING OFFICER OR REPRESENTATIVE: \_\_\_\_\_

SIGNATURE: \_\_\_\_\_

CUT HERE AND RETURN



DEFENSE NUCLEAR AGENCY  
ATTN: IMAS  
6801 TELEGRAPH ROAD  
ALEXANDRIA, VA 22310-3398

DEFENSE NUCLEAR AGENCY  
ATTN: IMAS  
6801 TELEGRAPH ROAD  
ALEXANDRIA, VA 22310-3398

**REPORT DOCUMENTATION PAGE**

Form Approved

OMB No. 0704-0188

Public reporting burden for this collection of information is estimated to average 1 hour per response including the time for reviewing instructions, searching existing data sources, gathering and maintaining the data needed, and completing and reviewing the collection of information. Send comments regarding this burden estimate or any other aspect of this collection of information, including suggestions for reducing this burden, to Washington Headquarters Services Directorate for Information Operations and Reports, 1215 Jefferson Davis Highway, Suite 1204, Arlington, VA 22202-4302, and to the Office of Management and Budget, Paperwork Reduction Project (0704-0188), Washington, DC 20503.

1. AGENCY USE ONLY (Leave blank)		2. REPORT DATE 951101	3. REPORT TYPE AND DATES COVERED Technical 940707 - 950212	
4. TITLE AND SUBTITLE  Batteryless Sensor for Intrusion Detection and Assessment of Threats			5. FUNDING NUMBERS C - DNA 001-94-C-0085 PE - OSD PSAEG PR - RF TA - DB WU- DH602040	
6. AUTHOR(S) Gerald F. Ross (Principal Investigator), Joseph D. DeLorenzo, Walter K. Kahn and Lee R. Cain				
7. PERFORMING ORGANIZATION NAME(S) AND ADDRESS(ES)  ANRO Engineering Inc. 450 Bedford Street Lexington, MA 02173			8. PERFORMING ORGANIZATION REPORT NUMBER	
9. SPONSORING/MONITORING AGENCY NAME(S) AND ADDRESS(ES) Defense Nuclear Agency 6801 Telegraph Road Alexandria, VA 22310-3398 NOSA/Witter			10. SPONSORING/MONITORING AGENCY REPORT NUMBER  DNA-TR-95-21	
11. SUPPLEMENTARY NOTES  This work was sponsored by the Defense Nuclear Agency under RDT&E RMC Code B2638D RF DB 60204 2352A AE 25904D.				
12a. DISTRIBUTION/AVAILABILITY STATEMENT  Approved for public release; distribution is unlimited.			12b. DISTRIBUTION CODE	
13. ABSTRACT ( <i>Maximum 200 words</i> )  This summary report describes the findings of a Phase I SBIR program to develop a batteryless and wireless sensor designed to monitor door and window openings/closings. The sensor radiates a coded signal to a central processor unit which identifies the location of the entry and can time code the event. The sensor works by converting the mechanical energy available by a door/window movement to a dc voltage which powers an imbedded tone modulated oscillator. The program concentrated on the development of the most efficient means to convert the available mechanical energy into electrical energy, as well as a means to effectively radiate the alerting signal. Four different energy conversion sources were developed. Two receivers were also designed and developed for use with the sensors. The sensors were located both in the jamb and doorknob. Installation studies, as well as experiments, were conducted to determine the range of the sensor signal which can be up to one mile. The practical range depends on the sensor location. Based on the highly successful conclusion of Phase I, it was decided to submit a Phase II proposal in concert with an experienced sensor manufacturer to exploit the commercial aspects of this sensor.				
14. SUBJECT TERMS Security Sensor                      Low-Cost Door/Window Monitoring        Easy Installation Batteryless and Wireless        Coded for Location			15. NUMBER OF PAGES 58	
			16. PRICE CODE	
17. SECURITY CLASSIFICATION OF REPORT UNCLASSIFIED	18. SECURITY CLASSIFICATION OF THIS PAGE UNCLASSIFIED	19. SECURITY CLASSIFICATION OF ABSTRACT UNCLASSIFIED	20. LIMITATION OF ABSTRACT  SAR	

**UNCLASSIFIED**

SECURITY CLASSIFICATION OF THIS PAGE

CLASSIFIED BY:

N/A since Unclassified.

DECLASSIFY ON:

N/A since Unclassified.

SECURITY CLASSIFICATION OF THIS PAGE

**UNCLASSIFIED**

## SUMMARY

Different energy sources, transmitters, antennas, and receivers were investigated during Phase I to determine the feasibility of developing a small and cost-effective batteryless and wireless sensor to monitor door and window openings/closings. A primary factor of the Phase I feasibility study was the ease of installation of such a sensor in existing buildings. It was found that a microminiature permanent magnet (PM) motor and gear train combination could be used very effectively as a generator to convert the mechanical energy available, for example, in the opening or closing of a door or the turning of a door handle to power a coded VHF oscillator compactly collocated with the energy source. Different types of antennas were investigated to support the propagation of the VHF signal radiated from the sensor. It was found that the microminiature PM generator chosen was more cost effective than a piezoelectric source suggested earlier for investigation.

Several models of the sensor were constructed and tested under Phase I. It was found that a rack and pinion mechanical coupling was most effective for use in the jamb of a door or sill of a window. A covert installation, where the energy conversion source is placed directly in the door-knob, is recommended for certain applications. Here, the doorknob and the intruder serve as the antenna.

Based on the success of Phase I, a Phase II program is recommended where the operating frequency of the sensor is extended to 900 MHz for size reduction, and coding is installed to suppress electromagnetic interference. Important to the success of the Phase II program is the choice of a Phase II/III partner experienced in the development, manufacture and distribution of security sensors. ANRO has conducted extensive market research and interviewed several potential partners for this program and is currently preparing a Phase II proposal together with Advantor Corporation, Orlando, Florida. Advantor is one of the leading large businesses in the security market.

Accession For	
NTIS CRA&I	<input checked="" type="checkbox"/>
DTIC TAB	<input type="checkbox"/>
Unannounced	<input type="checkbox"/>
Justification .....	
By .....	
Distribution / .....	
Availability Codes	
Dist	Avail and / or Special
A-1	

## TABLE OF CONTENTS

Section	Page
SUMMARY .....	iii
FIGURES .....	vi
TABLES .....	vii
1 INTRODUCTION .....	1
1.1 GENERAL .....	1
2 MECHANICAL/ELECTRICAL ENERGY CONVERSION .....	3
2.1 INTRODUCTION .....	3
2.2 RACK & PINION .....	3
2.3 COVERT MOUNTING OF GENERATOR/GEAR TRAIN WITHIN KEY/LOCKSET .....	5
2.4 PIEZOELECTRIC ENERGY SOURCE .....	8
3 THE TRANSMITTER .....	11
3.1 INTRODUCTION .....	11
4 ANTENNA DEVELOPMENT .....	14
4.1 INTRODUCTION .....	14
4.2 DIPOLE ANTENNAS .....	14
4.2.1 Application at 50 MHz .....	14
4.2.2 Covert circumferential dipole antenna for nonconductive doors .....	15
4.2.3 Extended Doorknob Monopole .....	15
4.2.4 Covert Microstrip Antenna .....	16
5 PROPAGATION IN VARIOUS ENVIRONMENTS .....	19
5.1 Regulatory Considerations in the US .....	19
6 THE BREADBOARD RECEIVER .....	21
6.1 INTRODUCTION .....	21
6.2 RECEIVER PERFORMANCE .....	21
6.3 RECEIVER TUNING .....	23
6.3.1 Local Oscillator Adjustment .....	24
6.3.2 RF Amplifier Adjustment .....	24
7 CONCLUSIONS AND RECOMMENDATIONS .....	25

TABLE OF CONTENTS (Continued)

Section	Page
Appendix	
A BATTERYLESS SENSOR USED IN SECURITY APPLICATIONS .....	A-1
B MOTOR CONSTRUCTION AND USE .....	B-1
C THEORY OF THE MICROSTRIP PATCH ANTENNA, CAVITY MODEL, FOR USE ON A METAL DOOR .....	C-1

## FIGURES

Figure	Page
2-1 Improved rack and pinion version of Batteryless Sensor .....	4
2-2 Top view of door and lockset .....	6
2-3 Regulated ersatz power supply .....	7
2-4 Anvil press to simulate door jamb forces .....	9
3-1 Transmitter/antenna arrangement .....	11
3-2 Modified tone generator .....	13
4-1 Totally flush patch antenna for metal door installation .....	17
4-2 Top-loaded dipole antenna .....	18
6-1 Schematic diagram of the receiver .....	23
A-1 Patent .....	A-2
B-1 Winding approach used in motors with iron core construction .....	B-1
B-2 Skew wound technique typically used in ironless core construction .....	B-2
C-1 Microstrip antenna cross-section .....	C-1
C-2 Resonant frequency .....	C-4

## TABLES

Table	Page
3-1 Tone generator truth table .....	13
4-1 Measurement of radiated signal .....	15
5-1 Path loss measured in different buildings .....	20
6-1 Code selection .....	21

## SECTION 1

### INTRODUCTION

#### 1.1 GENERAL.

This report was prepared in response to the work performed on a Small Business Innovation Research program, Phase I Contract #DNA001-94-C-0085, to determine the feasibility and development of a batteryless, wireless, door or window sensor for use in monitoring openings/closing in government and commercial buildings. The requirement for sensor and sensor systems to improve the security of facilities housing nuclear weapons or stores against various unauthorized access is the prime motive of the program. Specifically, we have focussed on the detection and entry into sensitive precincts by intruders who may somehow succeed in gaining unauthorized, but otherwise normal, access to the main facility.

The major advantages of a batteryless and wireless sensor placed on doors and windows are that its installation can be done simply and it can be made cosmetically covert. No maintenance costs are required, because there is no need to replace batteries; battery replacement is not only expensive, but reveals sensor location. The signal generated by the actual opening or closing of a door/window can be received 100's or 1000's of feet distant inside or outside the building depending on the antenna employed and the operating frequency of the solid state transmitter. The power for the transmitter is generated by converting the kinetic energy produced by the opening/closing motion to an ersatz dc power supply; the voltage need last only 150 ms. A sensitive receiver was designed to detect this signal FM tone coded to a location; later models can be made to time tag the response. For the Phase I program, only four different tone signals were transmitted to code location.

On the program, different versions of the energy conversion source were investigated. The original patented version included a miniature permanent magnet (PM) generator and gear train which used a belt and pulley to convert the linear translation of a small protruding rod located in the jamb of the door. On Phase I, a simple rack and pinion, combined with a microminiature PM generator gear train, was successfully developed. In addition, a novel, completely convert, installation with this same motor/gear train placed in the knob of the door was developed. Here, the doorknob, together with the intruder, constitute the antenna. This work, together with piezo-electric energy source development is reported in Section 2.

The transmitter and antenna development for both the door jamb and doorknob installation is presented in Section 3. A study of propagation within a building was performed showing the signal energy within a building varies between a  $1/R^2$  and  $1/R^4$  law, where R is the distance from the source and the actual signal level depends on the construction of the facility; this work, including two excellent literature references, is reported in Section 5. The receiver we used was developed for ANRO by a subcontractor. It operates at about 50 MHz, using a monopole or chip antenna, and uses batteries; it measures about 12 cu. inches.

The demodulating channels in the receiver correspond to the FM tone code of the two sensors developed under the Phase I program. The design of the breadboard receiver is described in Section 6.

Finally, the Conclusions and Recommendations of this study are reported in Section 7. It is concluded that the feasibility of the concept has been reduced to practice under Phase I and it is recommended that a Phase II effort be launched in concert with a large, experienced, security system company as a subcontractor, to ensure that the devices produced are both cost-effective and marketable.

The concept of the batteryless/wireless sensor has been well received by those introduced to the concept. We have just been notified that the American Defense Preparedness Association has accepted a paper describing the batteryless/wireless sensor concept for presentation at its 11th Annual Security Technology Symposium to take place June 19-22, 1995 in Virginia Beach, Virginia. We have also conducted exploratory talks with recognized firms experienced in the security business in seeking a large business partner for Phase II/III. One such firm, Advantor Corporation, Orlando, Florida, appears to offer an excellent prototype, manufacturing, and marketing/distribution capability. They have expressed an interest to help us develop and market this product as part of a business agreement.

The patent of the batteryless sensor, Patent #5,317,303, entitled "Batteryless Sensor Used in Security Applications", was issued on May 31, 1994. An improvement patent based on the work performed under the Phase I program and, essentially, described in Section 2 of this report, was delivered to ANRO's patent attorney on March 1, 1995. He is currently preparing a patent application which should be filed on/or before April 1, 1995.

## SECTION 2

### MECHANICAL/ELECTRICAL ENERGY CONVERSION

#### 2.1 INTRODUCTION.

The basic door/window sensor was patented by ANRO in May 1994 and is presented in Appendix A for reference (U.S. patent #5,317,303). The patent converted a linear translation of a rod, which is depressed, for example, when the door is closed, to a rotary motion used to turn a permanent magnetic (PM) generator through the action of a belt and pulley. Although a miniature generator and associated gear train were employed, the size of the unit was still judged too large (e.g., 2.3 cu. inches) for general installation.

A new subminiature PM generator/gear train was found on the Phase I program which made the installation much more practical. The unit is described in more detail in Section 2.2 and Appendix B; the new generator/gear train has a volume of 0.387 cu. inches which represents only 15% of the original breadboard unit.

The gear and pulley was replaced by a more efficient rack and pinion, or spur gear, eliminating the belt and possible malfunction. The rack and pinion arrangement is discussed in Section 2.2.

A second novel technique was developed under Phase I to place the new subminiature PM generator/gear train into a doorknob, converting the rotation of the knob directly into a translation of the generator. We have coupled the output of the VHF oscillator to the doorknob so that the intruder, together with the knob, serve as the antenna. This scheme was successfully reduced to practice and is described in Section 2.3.

We have also experimented with and reduced to practice, a piezoelectric energy source for this same application. Although the energy source was demonstrated to operate using an anvil press to simulate the forces available in the jamb of the door, it was judged to not be cost-effective at this time. The piezoelectric work is reported in Section 2.4.

#### 2.2 RACK & PINION.

The generator/gear train in the above-referenced patent has been replaced by a much smaller and more efficient version. The new generator/gear train is manufactured both in Germany and Switzerland by the Faulhaler Group; the U.S. distributor is Micro Mo Electronics, St. Petersburg, Florida. We use Model #1516E06516A, which includes a 262:1 gear reduction train. It is described as a 12 volt permanent magnetic motor. The size of the improved unit, including the gear train,

is 0.63 in. diameter x 1.24 in. long (excluding 0.4 in. long shaft). We connect a 9/16 inch spur gear to the motor/generator shaft that drives a rack as shown in Figure 2-1 with matching teeth (e.g., 14 teeth/inch); the rack is made from 1/8 inch square steel stock.

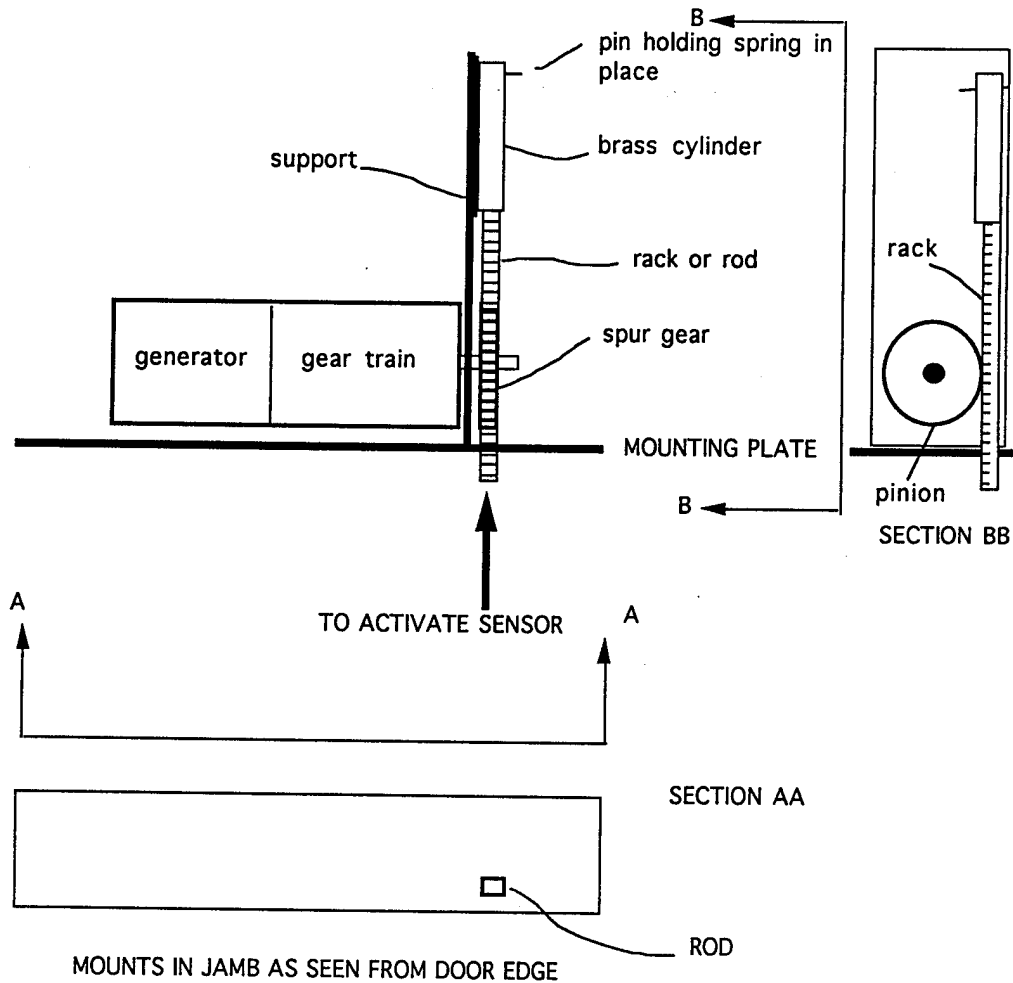

Figure 2-1. Improved rack and pinion version of Batteryless Sensor.

The rack is connected to a brass cylinder on one end by either epoxy or in our case, solder (Note: the steel was cleaned using muriatic acid and tinned preparing it for soldering). This brass cylinder telescopes into a second, somewhat larger, cylinder. Inside this larger cylinder is a spring. The spring is held in place by a pin. The rack, or rod, extends about 3/8" above the mounting surface, as shown in Figure 2-1. The entire unit, together with the electronic package, is mounted in the jamb of the door or in the sill of a window.

When the door/window is closed, the rod is depressed against the spring by about 3/8 inch. When the door/window is opened, the spring force drives the rod "up", turning the spur gear, gear train, and PM generator producing sufficient energy to radiate a 1-10 mw signal over a 150 ms duration. When the door closes, the action reverses; the rod is driven down and the generator spins in the opposite direction. A full-wave bridge rectifier converts the alternating voltage/current generated by this rotation, either CW or CCW, directly to an ersatz  $V_{cc}$  supply of fixed polarity to drive an oscillator. The entire electronic package (i.e., including the transmitter) fits within the jamb of a door. The overall size of the package is 2-1/2 in. x 1-1/8 in. x 2 in. (deep).

The type of antenna depends upon whether a wood or metal door is employed and the operating frequency of the oscillator. We have used a dipole with the existing transmitter successfully by using the door itself as a frame for the antenna; the wire is in a tape attached to the door for quick installation. For the metal door, a so-called patch antenna is employed. The antenna development is described in Section 4 and Appendix C. The higher the operating frequency, the smaller the antenna size required for efficient radiation. We are now operating at about 50 MHz because of the availability of low-cost components used currently in portable cordless phones, and hope for future models to extend the operating frequency to 900 MHz.

### 2.3 COVERT MOUNTING OF GENERATOR/GEAR TRAIN WITHIN KEY/LOCKSET.

In a large number of locksets, the Faulhaler generator/gear train described earlier can be placed directly in the doorknob, as shown in a top view in Figure 2-2.

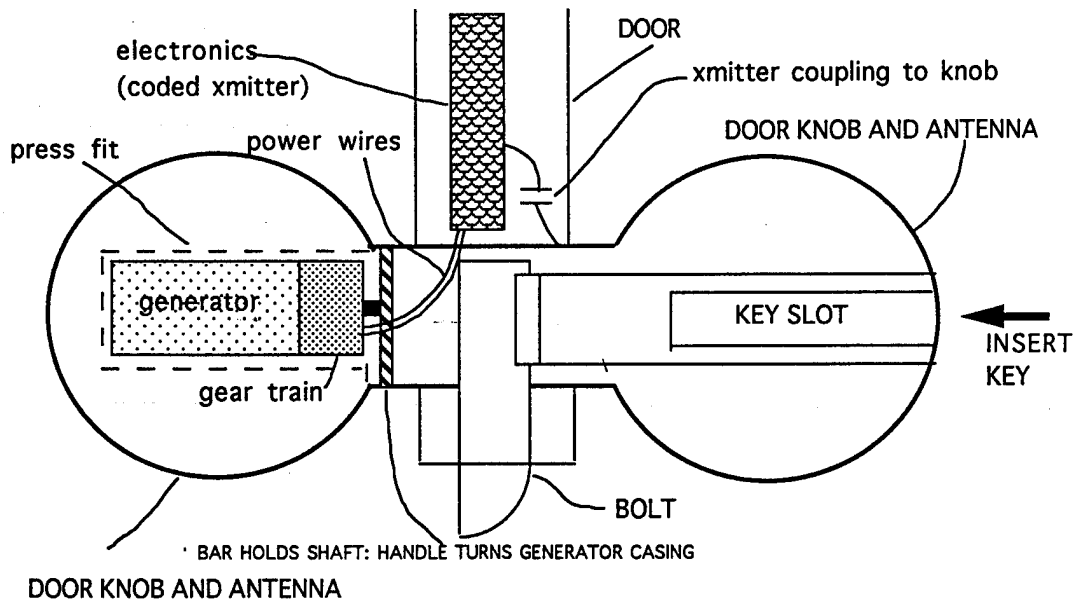

Figure 2-2. Top view of door and lockset.

Here, the doorknob, which also serves as the antenna, is capacitor coupled to the transmitter output tank circuit. In a typical lockset, there are two threaded screws which hold both parts of the lockset together when they are placed on both sides of the door. We press fit the case of the generator/gear train in contact with the knob subassembly so that as the knob turns, the case of the generator/gear train also turns. A brass bar supported in place by the two screws holding both parts of the doorknob together is physically connected to the shaft of the PM generator/gear train preventing it from rotating. In this manner, as the handle turns, the generator/gear train casing turns, but the armature is locked. An EMF is generated because of the relative motion of the armature and the (PM) field pieces.

The output leads from the armature of the generator are filtered by running them through a series of six ferrite beads. This is to suppress 50 MHz feedback into the transmitter/oscillator and tone coding circuitry. This is necessary because the output of the transmitter tank circuit is coupled through a 33 pf capacitor to the doorknob itself, which also serves as the antenna. At 50 MHz, this represents about 100Ω reactance. Note that this is not the most efficient coupling scheme; the coupling must be loose enough to permit oscillation, while tight enough to provide for maximum effective radiated power (erp).

We have also made a change in the rectification circuit. To ensure the same polarity output to drive the transmitter (e.g., +6 volts), when the doorknob is opened (CCW) or closed (CW), a full-wave bridge is employed as shown in Figure 2-3. The new components provide greater circuit efficiency.

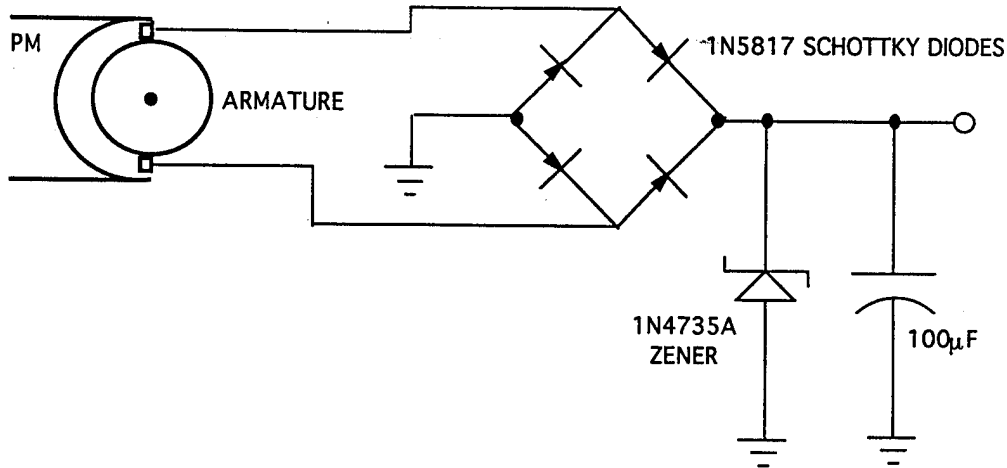

Figure 2-3. Regulated ersatz power supply.

It is desirable to obtain the oscillator operating  $V_{cc}$  (i.e., the ersatz power supply) with a slow turning of the knob. We have found, by experiment, that we could eliminate the 78L05 regulator and the DF02M full-wave bridge rectifier indicated in the original patent by using lower voltage drop components; namely, a Schottky diode bridge rectifier (e.g., 1N5817; 1A, 20 volts) and a single Zener diode (e.g., 1N4735A; 6.2 volts, 1 watt); the Schottky diodes cost about 40¢/each, while the Zener are 25¢/each in small quantities.

The rack and pinion arrangement, as described in the first section, or the covert doorknob installation, produces sufficient energy to activate the oscillator and its tone generator. The resistance of the armature of the current generator unit is about  $120\Omega$ , which means the available power at 5 volts into a  $1,000\Omega$  oscillator load is 25 mw.

To measure the effectiveness of the doorknob itself as an antenna, we set up an experiment using a tuned dipole @ 50 MHz as a "baseline" antenna. It is difficult to measure effective range of the sensor because range depends on the quality of contact between the person and doorknob as well as the size of the intruder. Even without a person holding on to the knob, (with the ersatz supply provided by a separate pulser), the range was about 100 feet @ 50 MHz. Here, the knob

was placed on a wooden door. If the knob was insulated, but placed on a metal door frame which acted as a ground plane, the distance would likely be substantially increased. Also, the range should be improved by increasing the operating frequency toward 900 MHz.

The transmitter and the tone coding circuitry, although modified somewhat in the course of the Phase I program, is, essentially, the same as suggested in the original patent. For future models we plan to send a train of four pulses; for example, each pulse having a duration of 25 ms separated by a dead time of 25 ms. The center frequency  $f_0$ , will continue to be tone modulated as presently performed. The idea here is to significantly reduce the probability of a false alarm by requiring at the receiver that at least three out of four hits are received at a prescribed tone before we declare an intrusion.

Finally, a word about installation. The electronics package shown in Figure 2-2 can be placed in a cylindrical cavity which can be drilled from the edge of the door through an opening already available to accommodate the bolt or tongue of the lock. The present electronics package fits into a hole that is 4-1/2" long and 7/8" diameter. The prototype models incorporating surface mount technology should be much smaller.

#### 2.4 PIEZOELECTRIC ENERGY SOURCE.

To derive sufficient energy from a piezoelectric ceramic crystal to operate the batteryless door/window sensor, requires certain circuit novelty. A piezoelectric crystal is a form of capacitor where energy caused by distending the crystal results in a charge buildup on the surface of the material. The charge buildup is a function of the force/unit area on the crystal material as well as the rate of change of that force; the larger the rate of change, the more energy output. Also, the larger the volume of piezoelectric material, the more energy output can be expected. The cost of piezoelectric material increases exponentially with increasing material volume. For example, a slab of a piezoelectric ceramic block made by Ferroperm, Inc. and measuring 2 in. x 1 in. x 0.2 in., costs \$26 in small quantities.

If one tries to connect a load (e.g., a 1,000 $\Omega$  oscillator load) directly to the output terminals of the ceramic block, there is no energy output. This is because the charge on the piezoelectric crystal leaks off faster than it builds up. We found, experimentally, that the ideal way to extract energy from the ceramic piezoelectric material is to ensure that the output terminals drive an effective "open circuit" until a threshold voltage is reached. At that point, a switching action lets the charge that has built up, discharge and excite a load through a low-pass filter. One switching device we have used for this application is a 700 volt type RS (gas) flash tube available at Radio Shack for \$4.

The ceramic block was designed to fit in the jamb of the door. The force available from the opening/closing action of the door at the crystal is substantial and is determined by the large ratio of the distance from the knob to the hinge divided by about half of the length of the ceramic slab (e.g., about 70:1). In this manner, a 1 pound force applied to closing the door translates to about 70 pound force at the piezoelectric slab. We tried to simulate this large force in a controlled experiment by the use of a small anvil press, as shown in Figure 2-4, using 1/2 inch phenolic and brass pressure plates, as shown, to hold the PZT piezoelectric material. With about a 70 pound force applied by the press, the material generated a 50 volt peak signal of 10 ms duration into a 1 meg  $\Omega$  load. A moderate hammer blow (e.g., an impulsive force) gave about the same output voltage, but the duration of the output was only 3 ms. By using a 100 meg  $\Omega$  load instead, the output voltage approached 360 volts. By using a silicon-controlled rectifier load (MCR100-8), as much as 30 volts, with a duration of 100 ms, was obtained in conjunction with a LPF. A virtual open circuit until breakdown of a threshold switching device performs the best. A voltage that exceeds 750 volts and breaks down a gas tube placed in series with the crystal can produce between 5-12 volts at the output of a low-pass filter network feeding a load.

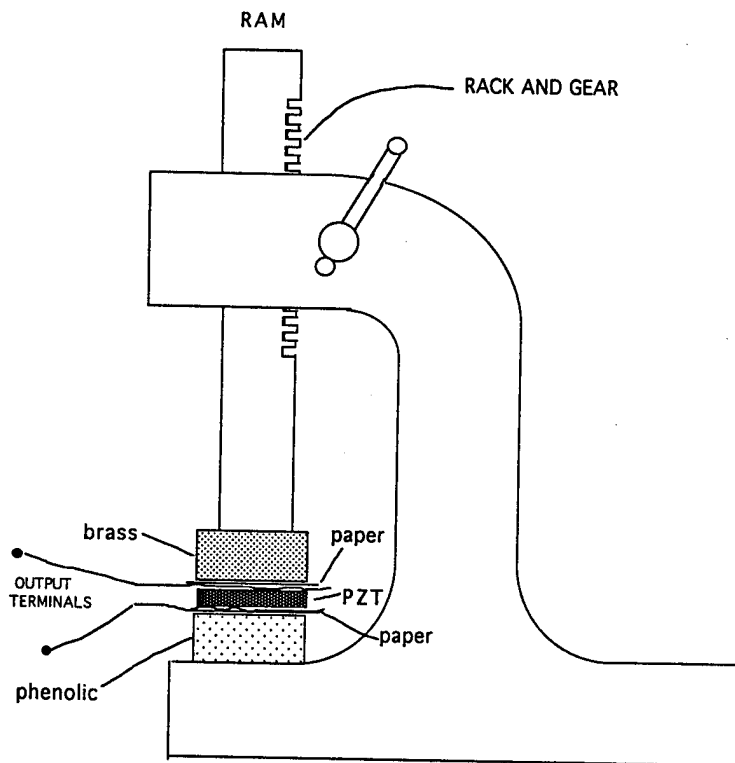

Figure 2-4. Anvil press to simulate door jamb forces.

The conclusion from the investigation is that a virtual, open circuit, threshold device, in conjunction with LPF post filtering, is required when using a piezoelectric energy source. The device can be either a flash tube, where the voltage breaks down on inert gas, generating about a 700 volt pulse lasting a couple of milliseconds, or a metal oxide varistor (MOV) which is a solid state equivalent of the gas tube. In either case, the resulting pulse must be stretched sufficiently by a low-pass filter to reduce the peak voltage to between 5-12 volts when connected to a 1,000 $\Omega$  load; the duration of the ersatz supply should be in the order of several hundred milliseconds including the efficiency losses of the filter and the effects of the 1,000 $\Omega$  load.

## SECTION 3

### THE TRANSMITTER

#### 3.1 INTRODUCTION.

The output of the ersatz power supply, together with the Zener regulator shown in Figure 3-1, is fed to the MX503 tone modulator and, in turn, to the MC2833 RF generator (49.845 MHz oscillator) and modulator as shown in Figure 3-1. The signal output of the MC2833 oscillator chip is used in portable cordless telephone applications. The generator is modulated with CW tones ranging from 600 to 2435 Hz. The duration of the ersatz power supply created by the doorknob or jamb sensor movement is about 150 ms. The receiver is designed to respond to a tone lasting as short as 10 ms.

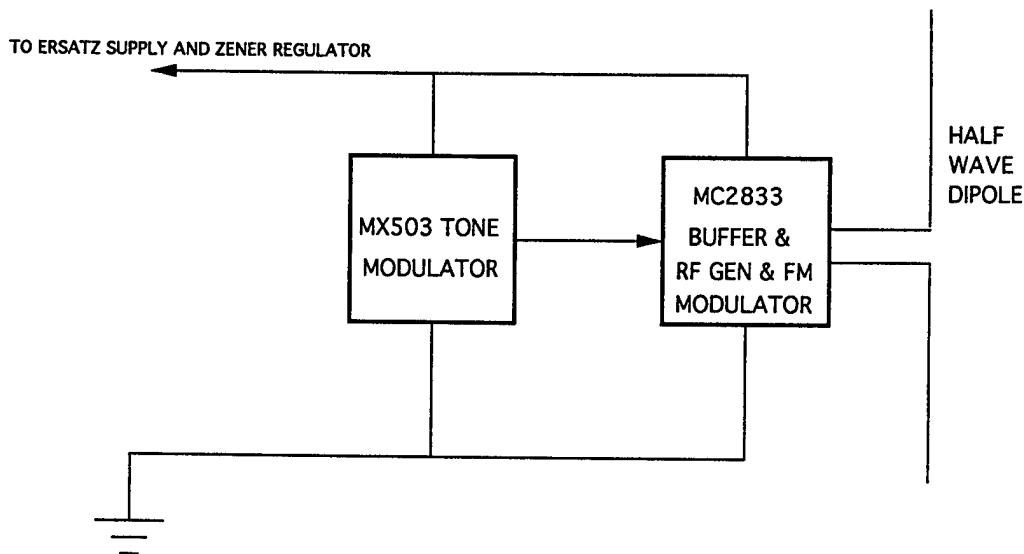

Figure 3-1. Transmitter/antenna arrangement.

It was calculated that to achieve a range of one mile, requires an effective radiated power of about 10 mw. Assuming the gain of a non-resonant dipole (e.g., to minimize the length of the antenna at 50 MHz) and an oscillator efficiency of about 40%, we can estimate the equivalent power supply load. For a  $V_{cc}$  of 5 volts, this corresponds to an equivalent load resistance of

$$R_L = \frac{(V_{cc})^2}{\text{Primary Power}} = \frac{25}{25 \times 10^{-3}} \sim 1k\Omega \quad (3.1)$$

Allowing some power to operate the tone generator and modulator, ANRO used for its initial testing an  $R_L = 750$  ohms. It was found that for a rod length of 1 inch and 120 degree rotation of the shaft in 1/2 seconds, a signal duration of 150 ms is radiated. Electrically, this is also a covert signal which is difficult to detect unless equipped with a specially designed receiver, as developed by ANRO's subcontractor, Multispectral Solutions, Inc., (MSSI) described in Section 4.

One change to the original circuit referred to in the patent shown in Appendix A is the addition of a buffer following the 49.845 crystal oscillator, as recommended by Motorola. A capacitor matching network was also used to couple to the dipole. It was found that the addition of the buffer and matching network significantly reduced harmonic spurious signals (e.g., -38 dB below the fundamental).

The modified tone encoding circuit using the MX503QA chip is shown in Figure 3-2. A three-position DIP switch was installed to match the MSSI receiver described in Section 4. Pin 12 is hard-wired in the high state to generate the four tones shown in the Truth Table (Table 3.1).

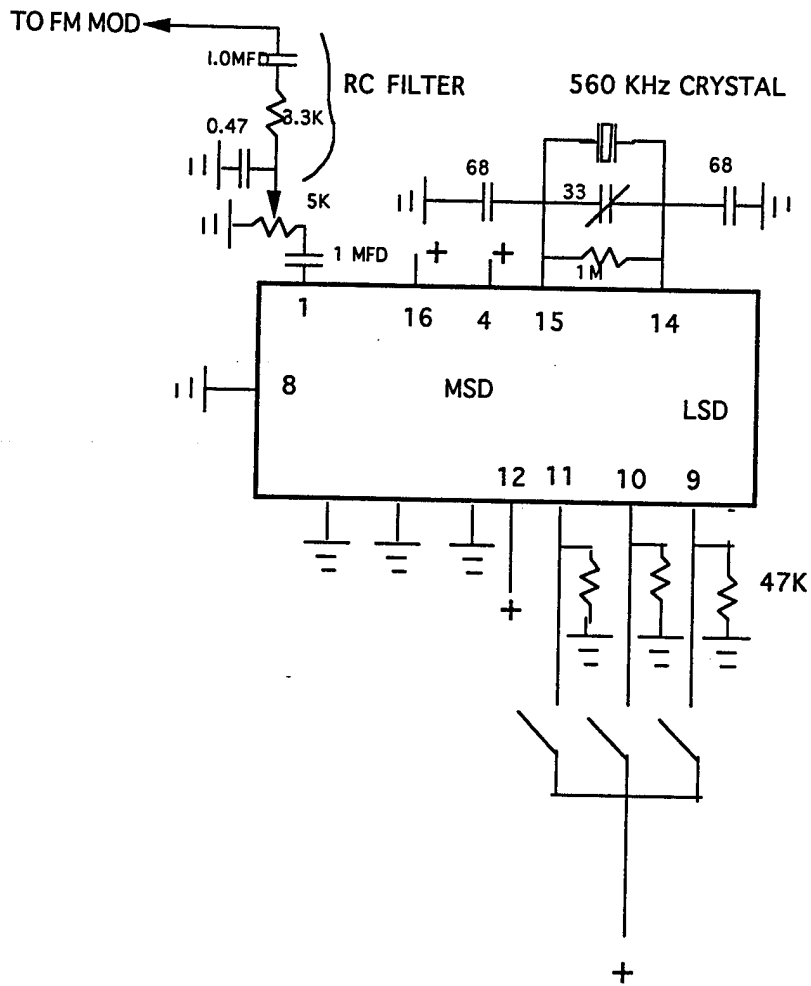

Figure 3-2. Modified tone generator.

Table 3-1. Tone generator truth table.

Calibrated Tone, Hz	Pin Number				Tone Measurement
	12	11	10	9	
1869	1	0	0	1	1864
2007	1	1	0	0	2011
2151	1	0	1	0	2151
2435	1	0	1	1	2431

## SECTION 4

### ANTENNA DEVELOPMENT

#### 4.1 INTRODUCTION.

Certainly, the simplest and often also the smallest and most efficient sort of antenna, is a form of dipole (including the half-dipole or monopole) antenna. Indeed, the very first experiments with electromagnetic radiation were conducted by H. Hertz with an antenna of this type. It follows that use of another type of antenna for a particular application must be justified by special requirement such as high directivity or environmental-physical constraint.

For the present application, near isotropic radiation characteristics are desired. If the environment -- door, window, and the closer frames for these, etc., are non-metallic non-conductors, a dipole, appropriately configured for covertness and ease of installation, is clearly the first antenna of choice. Two forms of dipole antennas were designed and constructed and tested at 50 MHz.

When the door is metallic or laminated with sheet metal, as is often the case in commercial-warehouse and military installations, an electric dipole mounted on the surface of the door would be short-circuited by the conducting material and could not radiate. Consequently a different antenna type is necessitated by this environment. The parallel plane structure of the metal lamination suggests the use of a stripline, patch antenna in this environment. While such antennas represent relatively recent innovations, the design principles governing their performance are now quite well understood. Design formulas for patch antennas appropriately configured for the door application were developed.

#### 4.2 DIPOLE ANTENNAS.

##### 4.2.1 Application at 50 MHz.

The primary consideration governing the design of the antenna for use at this frequency is the covert placement of a sufficiently large dipole. In this application, the very severe limitation on the available primary power demands an efficient radiator. No radiator (in particular, no dipole radiator) effectively smaller than one-half free-space wavelength radiates efficiently. At 50 MHz the free-space wavelength computes to 6 meters. A given conductor length can effectively be doubled through the use of a large conductive ground plane -- the monopole configuration. This option is evidently available only in conjunction with metal or metal laminated doors.

A particularly intriguing means for increasing the effective length of a short antenna, an antenna whose static length is only the length of a doorknob, utilizes the dielectric properties of the door opener (person) to effectively increase the antenna length.

#### 4.2.2 Covert circumferential dipole antenna for non-conductive doors.

A circumferential halfwave dipole @ 50 MHz antenna was constructed by constructing 3/4" pine strips to simulate a door frame. The vertical frame was placed proximal to the PM generator/gear train and electronics assembly. Propagation from the sensor was reviewed each time the mock-up door was opened and closed. A second similar dipole placed in the laboratory received signal levels at 50 MHz, as measured using a wideband scope as indicated in Table 4-1.

Table 4-1. Measurement of radiated signal.

Spacing between antennas	Scope voltage, p-p
4'	220 mv
8'	200 mv
15'	180 mv

We then operated the transmitter using a fixed dc supply. The results were the same.

Using the MSSSI receiver and monopole chip, we were able to receive the signal at least 2000 feet through the ANRO laboratory and building structure in the vicinity of the National Guard Armory on Bedford Street in Lexington, MA. We used a gated 150 ms duration supply to simulate the opening and closing of a door for this experiment.

#### 4.2.3 Extended Doorknob Monopole.

As has been suggested, a novel means for increasing the effective length of a short antenna, an antenna whose static length is only the length of a doorknob, utilizes the dielectric properties of the door opener (person) to effectively increase the antenna length.

The person-antenna interaction has recently received detailed attention in the literature<sup>1</sup>. Although the particular study cited focussed on hand-head interactions with portable cordless phone antennas at 900 MHz, the principles of person-antenna interaction studied and described as well as the computational techniques employed are clearly applicable at 50 MHz.

The range of the doorknob antenna appeared to be about 125 feet with no one holding the knob. When the knob is held, the range is greater, but it is difficult to quantify because it depends upon the body orientation as well as the contact with the knob. The antenna is also effective when an intruder is wearing a medical glove, because of the capacity coupling between the hand and the doorknob at 50 MHz; at higher frequencies the coupling is greater.

An interesting observation to make here is that if the knob can be insulated from a metal frame door, then it should make an effective alternative to the patch antenna. This requires operating at much higher frequencies; for example, 900 MHz.

#### 4.2.4 Covert Microstrip Antenna.

For metal laminated doors, a form of microstrip antenna has been designed that conforms to the door geometry and is readily concealed. This type of antenna can (but does not necessarily) use the outer metal door covering as an integral part of the antenna as shown in Figure 4-1. The theory underlying this type of antenna is presented succinctly in Appendix C. Dimensions for one design are shown in Figure 4-2. The pattern of the radiation from the slit aperture is that of a horizontal magnetic dipole (i.e., the same as that of a current loop in a plane the normal to which coincides with the slit aperture.)

---

<sup>1</sup> M. A. Jensen and y. Rahmat-Samii, "EM Interaction of Handset Antennas and a Human in Personal Communications." Proceedings of the IEEE, Vol. 83, No. 1 pp. 7-16, January, 1995.

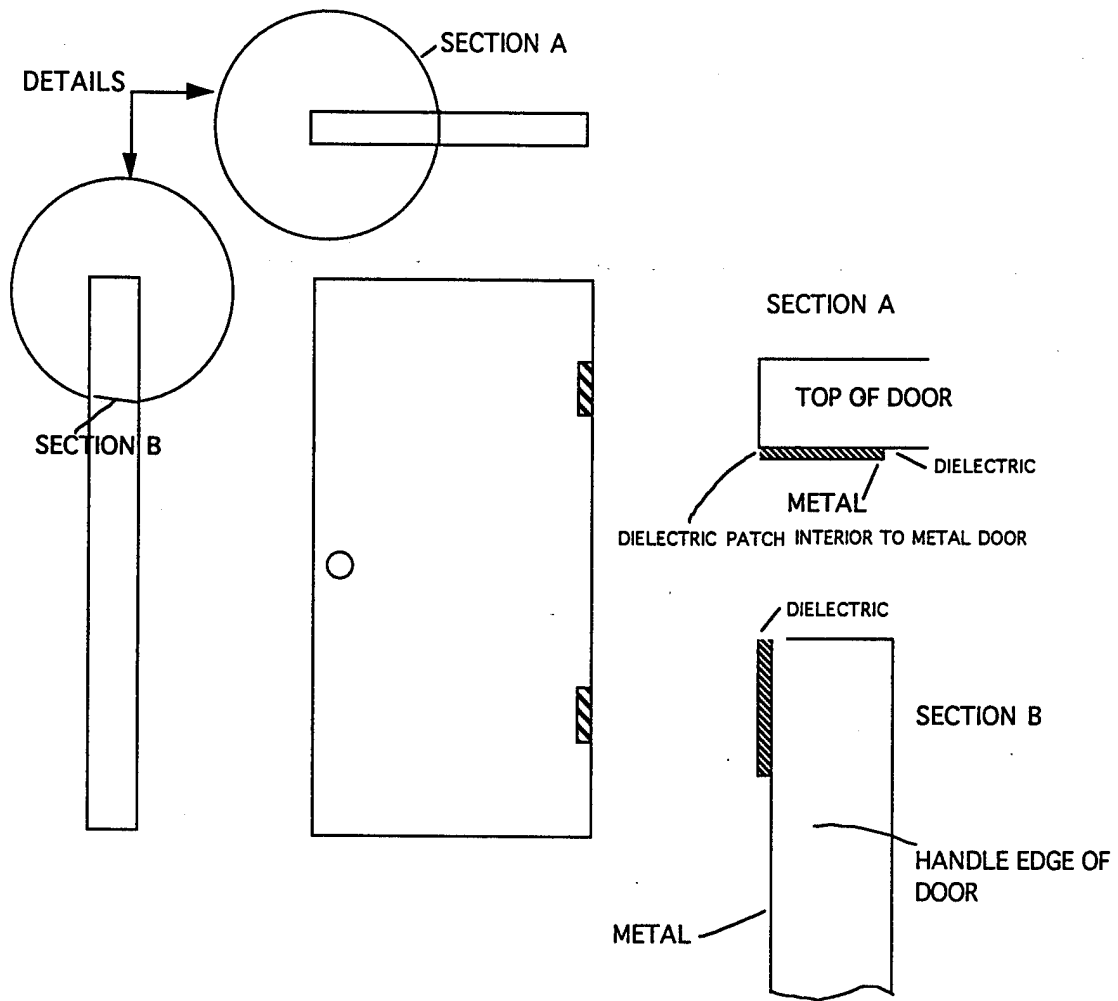

Figure 4-1. Totally flush patch antenna for metal door installation.

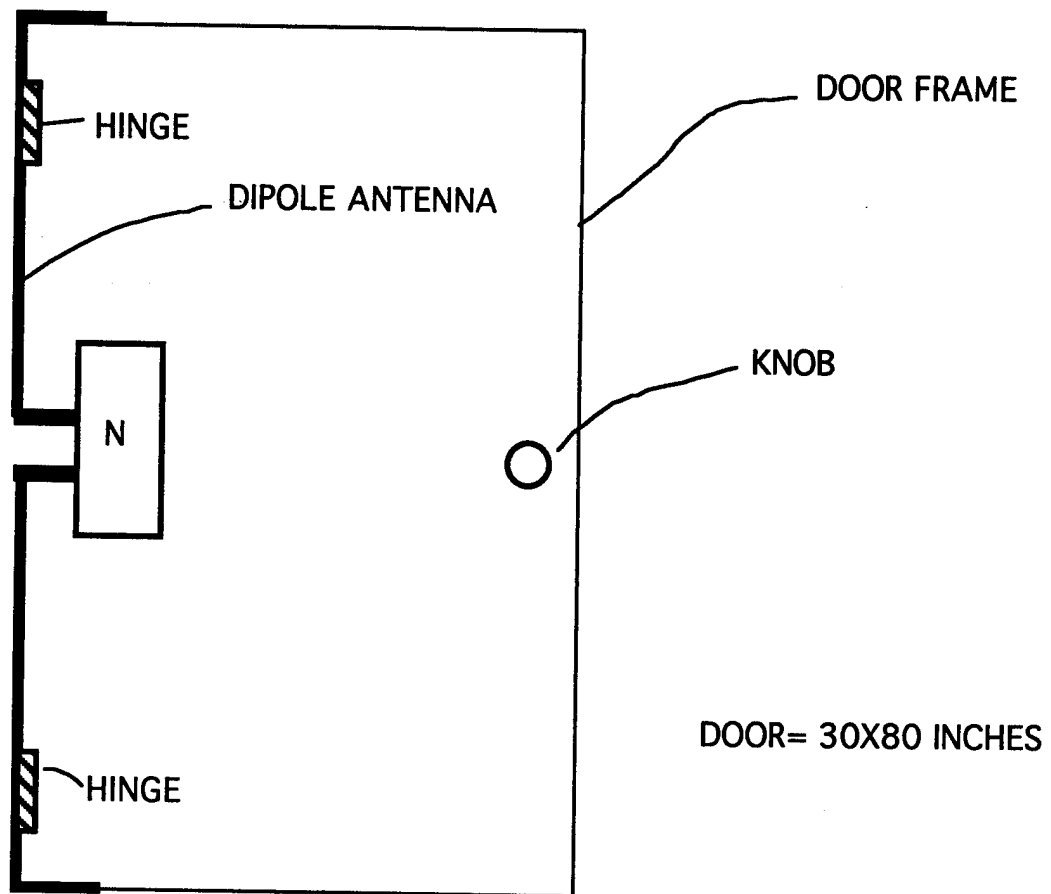

Figure 4-2. Top-loaded dipole antenna.

## SECTION 5

### PROPAGATION IN VARIOUS ENVIRONMENTS

#### 5.1 REGULATORY CONSIDERATIONS IN THE US.

Extensive experiments have verified a semi-empirical analytical model for the path loss  $PL(d)$  encountered in most complex environments including factories, office buildings and urban streets.<sup>2 3</sup>

Path loss describes the attenuation in the propagation environment, and is a measure of the channel attenuation at a specific location, relative to a close-in free-space reference<sup>2</sup>. Measurements have shown that a good path loss model at a specific transmitter-receiver (T-R) separation is given by:

$$\overline{PL}(d) [dB] = PL(d_0) + 10n \log_{10} \left( \frac{d}{d_0} \right) + X_{\sigma} [dB], \quad (5.1)$$

where  $\overline{PL}(d)$  is the mean path loss in dB, at a T-R separation of  $d$  meters;  $\overline{PL}(d_0)$  is the free-space path loss, at a close-in reference distance,  $d_0$ ; and  $n$  is a path-loss exponent, which describes how fast the mean path loss increases with distance<sup>2</sup>. For indoor measurement,  $d_0$  should be in the far field of the antenna, and  $\overline{PL}(d_0)$  is due to free-space propagation from the transmitter to  $d_0$ . The term  $X_{\sigma}$  in Equation (1), described the variation of path loss at a specific distance, for independent measurement locations, made throughout a large area.

The exponent  $n$  in the above formula is found to lie between roughly 2 and 4 (see Table 5-1).

---

<sup>2</sup> H. L. Bertoni, et al., "UHF Propagation Prediction for Wireless Personal Communications," Proceedings of the IEEE, Vol. 82, No. 9, pp. 1333-1359, September 1994. (116 References).

<sup>3</sup> T. S. Rappaport and Sandip Sandhu, "Radio-Wave Propagation for Emerging Wireless Personal-Communication Systems," IEEE Antennas and Propagation Magazine, Vol. 36, No. 5, pp. 14-23, October 1994. (57 References)

Table 5-1. Path loss measured in different buildings.

Building	n	$\sigma$ (dB)	Frequency (MHz)	Ref.
Grocery Store	1.8	5.2	914	12
Retail Store	2.2	8.7	914	12
Open-plan Factories	2.2	7.9	1300	13
Open-plan Factories	1.4-3.3		4000	14
Open-plan Factories B	2.0	3.7	1300	15
Open-plan Factories B	2.1	4.0	1300	15
Open-plan Factories C	2.4	9.2	1300	15
Open-plan Factories C	2.1	9.7	1300	15
Suburban office building - open plan	2.4	9.6	915	16
Suburban office building - open plan	2.6	14.1	1900	16
Suburban office building - soft partition	2.8	14.2	915	16
Suburban office building - soft partition	3.8	12.7	1900	16
Office building - hard partition	3		850	17

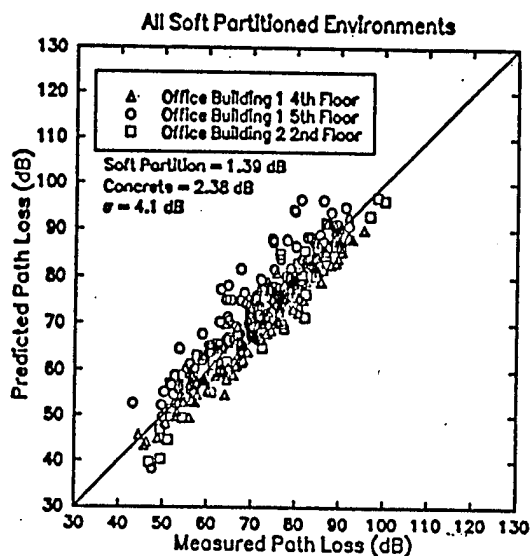

## SECTION 6

### THE BREADBOARD RECEIVER

#### 6.1 INTRODUCTION.

ANRO contracted with Multispectral Solutions, Inc. (MSSI), Gaithersburg, Maryland, to construct two receivers to detect different coded tones from the imbedded door/window sensors @ 49.845 MHz. This frequency was chosen for the Phase I development because of the availability of inexpensive cordless telephone componentry.

#### 6.2 RECEIVER PERFORMANCE.

The receiver, as indicated above, is tuned to 49.845 MHz and responds to a FM tone modulated signal with a 2.5 to 5 kHz deviation which appears for a duration of greater than 10 ms. This is an important parameter because the ersatz  $V_{cc}$  power supply has a duration of about 150 ms for a small deviation of the rod or turn of the doorknob.

The code selections available in the receiver are shown in Table 6-1. The receiver which is equipped with a simple chip antenna measures 15 cu. inches. A LED mounted on each receiver is used as an indicator. The receiver latches when the proper signal is received and can be reset by a 90 degree movement and the tilting of an internal mercury switch.

The sensitivity of the receiver is 0.18 volts for a minimum detectable 5 kHz deviation FM signal.

Table 6-1. Code selection.

Code	Frequency	Code	Frequency
0	600	8	1728
1	741	9	1869*
2	882	A	2151*
3	1023	B	2435*
4	1164	C	2007*
5	1305	D	2295
6	1446	E	459

\* Tuned to the ANRO Transmitter

The receiver was tested on the bench as well as in the field. Bench measurements were performed with an HP864B synthesized RF signal generator and counter, Tektronix 7704A oscilloscope with 7A26, 7B20 and 7B25 plug-ins, and a Stoddard AN/URM-47B (NM-30A) Radio Frequency Interference Measurement Set used for RF amplifier adjustment.

The receiver sensitivity was measured at 0.2  $\mu$ V for a stable, valid tone detection. Since an audio distortion analyzer was not available, SINAD (signal-to-noise and distortion) measurements could not be performed. Current draw of the receiver was significantly less than the specification required -- approximately 2.60 mA at 3.6 volts, well below the 4.0 mA requirement.

Outdoor tests were made with an earlier and lower power version of the ANRO batteryless sensor. The sensor transmitter was connected to a  $1/4\lambda$  dipole and the dipole taped to a window on the third floor of the building. The receiver was then taken outdoors and placed at various distances from the transmitter site.

The transmitter was keyed by either a door closure or opening and, with the receiver in its operating mode (i.e., LEDs facing upward), a visible indication of a received and decoded signal could be observed. Because of line-of-sight terrain limitations, a maximum range of only 2000 feet was possible.

Without radials, the receiver could not detect the transmitter much beyond 1000 feet; however, with radials in place, the receiver was able to detect and decode the transmitted burst at a maximum available distance of 2000 feet.

A schematic diagram of the receiver is shown in Figure 6-1.

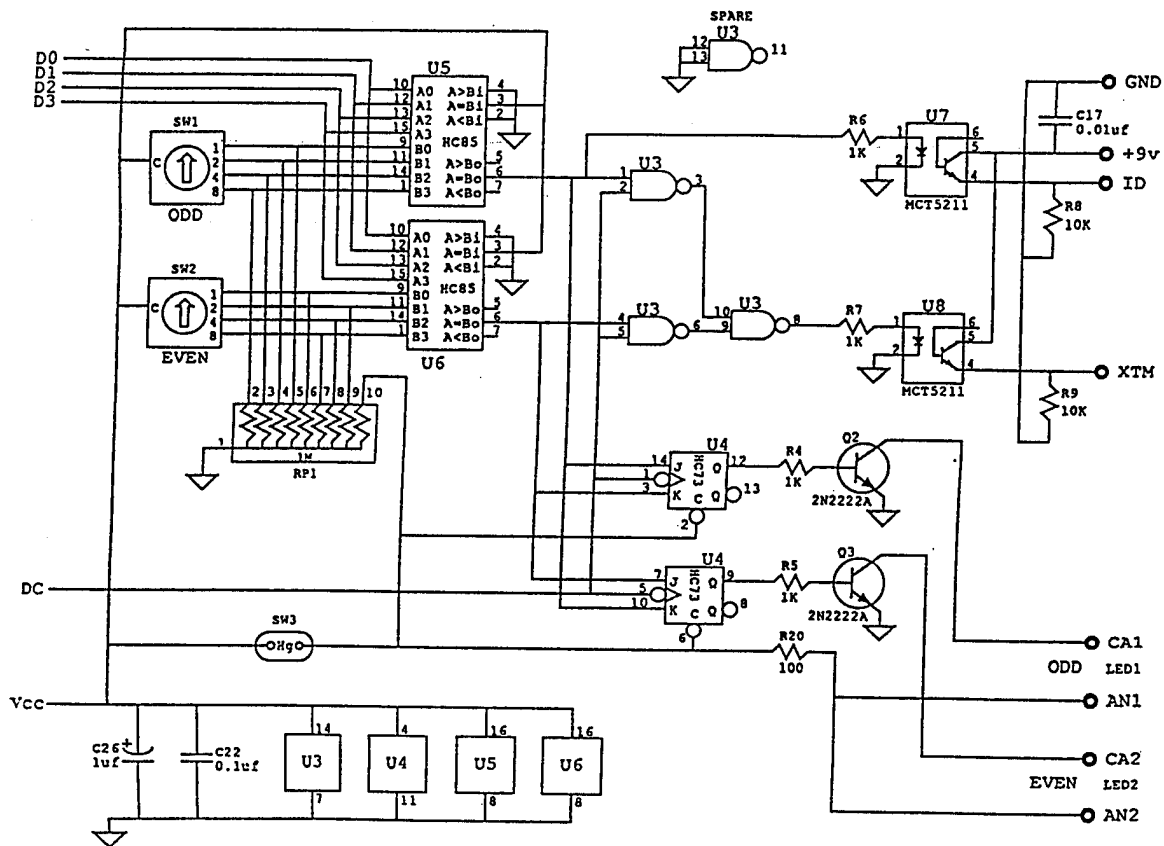

Figure 6-1. Schematic diagram of the receiver.

### 6.3 RECEIVER TUNING.

The prototype receiver has five adjustable components, four variable capacitors and a variable coil. Two of the capacitors are used in the bandpass filter circuitry before and after the RF amplifier; one capacitor is used for adjusting the local oscillator frequency; and the final variable capacitor is used to adjust the 560 kHz ceramic resonator used in the MA-COM decoder. The adjustable coil is the FM quadrature coil used by the MC3367 receiver.

### 6.3.1 Local Oscillator Adjustment.

The adjustment of the local oscillator frequency should be the first adjustment made to the DCSU receiver board. This is accomplished by attaching a low capacitance probe (less than 2 pF) to the end of the 1.2 $\mu$ H RF choke nearest the marking "C" on the PC board and connecting the other end to a high frequency counter. Note that additional RF amplification from the output of the probe to the counter may be required if a low sensitivity unit is used. Adjust the tuning capacitor (marked "C34") nearest to the crystal ("X2) for a measured frequency of 49.390000 MHz.

The above adjustments should be performed without an antenna connected to the receiver.

### 6.3.2 RF Amplifier Adjustment.

With the low capacitance probe connected, as in paragraph 3.1 above, attached the other end of the probe to a selective receiver (or spectrum analyzer) tuned to 49.845 MHz. Attach a signal source (49.845 MHz, FM deviation 5.0 kHz at 1000 Hz) to the antenna input and adjust the RF input level until an output indication (e.g., S-meter or calibrated attenuator level is observed. (NOTE: Since a significant amount of attenuation now exists between the antenna terminals and the output of the low capacitance probe, a large amount of RF -- several tenths of millivolts -- may be needed to observe a signal strength indication depending upon the type of measurement divide used.)

Adjust capacitors "C1" and C33" (capacitors on either side of A1, 2N918) for maximum S-meter deflection. These capacitors adjust the resonant frequencies of the two LC bandpass filters. Two peaks should be observed when tuning these capacitors. This is normal and either peak can be used for final adjustment.

## SECTION 7

### CONCLUSIONS AND RECOMMENDATIONS

- It is concluded that the development of a batteryless and wireless sensor as a security sensor for covert door/window mountings is practical and cost effective. It should have significant commercial, as well as government, applications.
- The most practical energy conversion scheme uses a micro miniature permanent magnetic generator together with its associated gear train to generate the power necessary to radiate a signal thousands of feet in free space and hundreds of feet within buildings. A version of the sensor located in the jamb of a door, for example, is attractive for simple installation. A covert installation where the generator, together with the transmitter electronics, is located in the doorknob, is particularly attractive for certain government installations.
- Several different types of antennas have been evaluated. A half-wave dipole is the most efficient radiator, but requires the use of the door as a frame and adds installation time. The use of the doorknob, itself, in addition to the intruder as the antenna, is particularly attractive. The range of this arrangement is much less than the thousands of feet obtained with the dipole; we measured about 150 feet using a center frequency of about 50 MHz.
- The choice of 50 MHz center frequency was dictated by the inexpensive availability of cordless portable phone components for the Phase I program. To decrease the size of the components, as well as the antenna and its associated installation requirements, it seems reasonable to explore the recently approved 900 MHz frequency band for further models. The propagation at this frequency should also be improved.
- The present receiver uses a single 150 ms duration pulse to indicate a door or window opening/closing. In high EMI areas, it is a better design to use a burst of four 25 ms pulses separated, where each pulse is separated by a 25 ms dead time. For a detection to then occur, we would require, for example, that three out of four pulses are received within a given 150 ms period. This requires a redesign of both the transmitter and receiver circuitry logic.
- Having proved the feasibility of the batteryless door/window sensor under Phase I, we recommend in a Phase II proposal to investigate different frequencies as well as different and, perhaps, more efficient, transmitters and receivers as described above.

- It is important to find a Phase II/III partner experienced with security sensors and that has a global distribution capability to ensure that the product we develop is marketable. We have interviewed a number of potential partners and find that Advantor Corporation, located in Orlando, Florida, proximal to our Sarasota office, has a prototype and manufacturing, as well as marketing capability. We have invited them to join with us in a Phase II proposal effort.

APPENDIX A



US005317303A

**United States Patent** [19]  
**Ross et al.**

[11] **Patent Number:** 5,317,303  
 [45] **Date of Patent:** May 31, 1994

[54] **BATTERYLESS SENSOR USED IN SECURITY APPLICATIONS**

[75] **Inventors:** Gerald F. Ross, Longboat Key, Fla.;  
 Richard M. Mara, Tewksbury;  
 Kenneth W. Robbins, North Reading,  
 both of Mass.; Robert J. Fontana,  
 Rockville, Md.

[73] **Assignees:** Anro Engineering, Inc., Lexington,  
 Mass.; Multispectral Solutions, Inc.,  
 Gaithersburg, Md.

[21] **Appl. No.:** 943,715

[22] **Filed:** Sep. 11, 1992

[51] **Int. Cl.<sup>5</sup>** ..... G08B 1/08; G08B 13/08

[52] **U.S. Cl.** ..... 340/539; 340/541;  
 340/545; 340/547; 340/549

[58] **Field of Search** ..... 340/539, 545, 547-549,  
 340/541, 540

[56] **References Cited**  
**U.S. PATENT DOCUMENTS**

3,614,760	10/1971	Zimmet .....	340/539
3,696,359	10/1972	Ross et al. ....	340/547
3,772,669	11/1973	Johnston et al. ....	340/539
3,781,836	12/1973	Kruper .....	340/547
3,818,467	6/1974	Willis .....	340/539
3,827,038	7/1974	Willis .....	340/539
4,170,005	10/1979	Duke .....	340/547

*Primary Examiner*—Donnie L. Crosland  
*Attorney, Agent, or Firm*—George Grayson

[57] **ABSTRACT**

A batteryless sensor includes a small and concealed permanent magnet motor which operates as a generator to convert rotational or translational energy to an ersatz Vcc transient power supply via a mechanical arrangement to radiate a coded VHF oscillator signal to a repeater or central processing unit located as far as one mile from the sensor. The receiver is able to monitor a multiplicity of sensor units over a given time period.

10 Claims, 5 Drawing Sheets

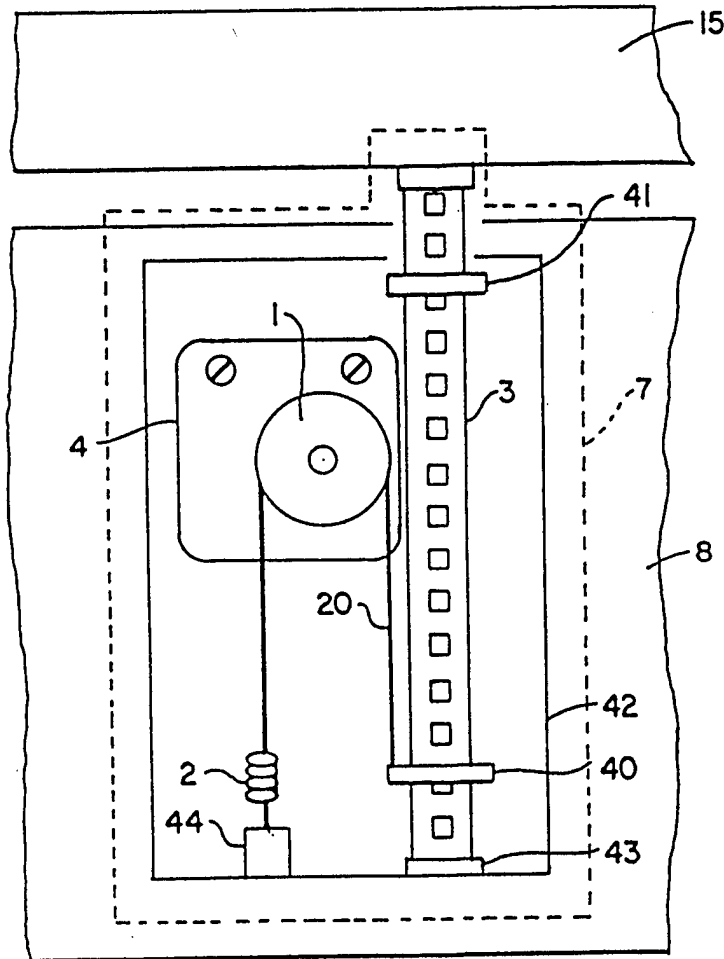

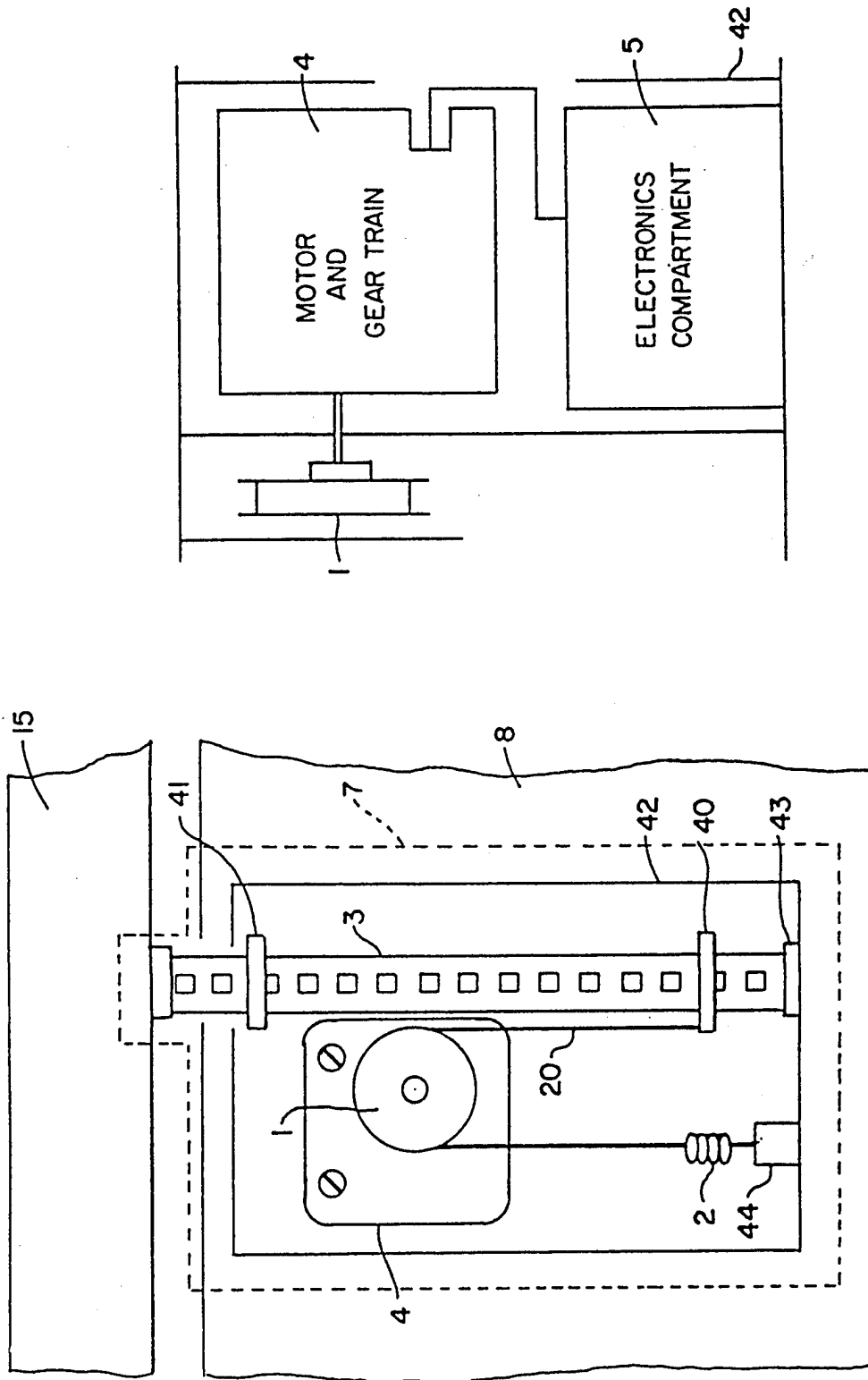

FIG. 1B

FIG. 1A

Figure A-1. Patent.

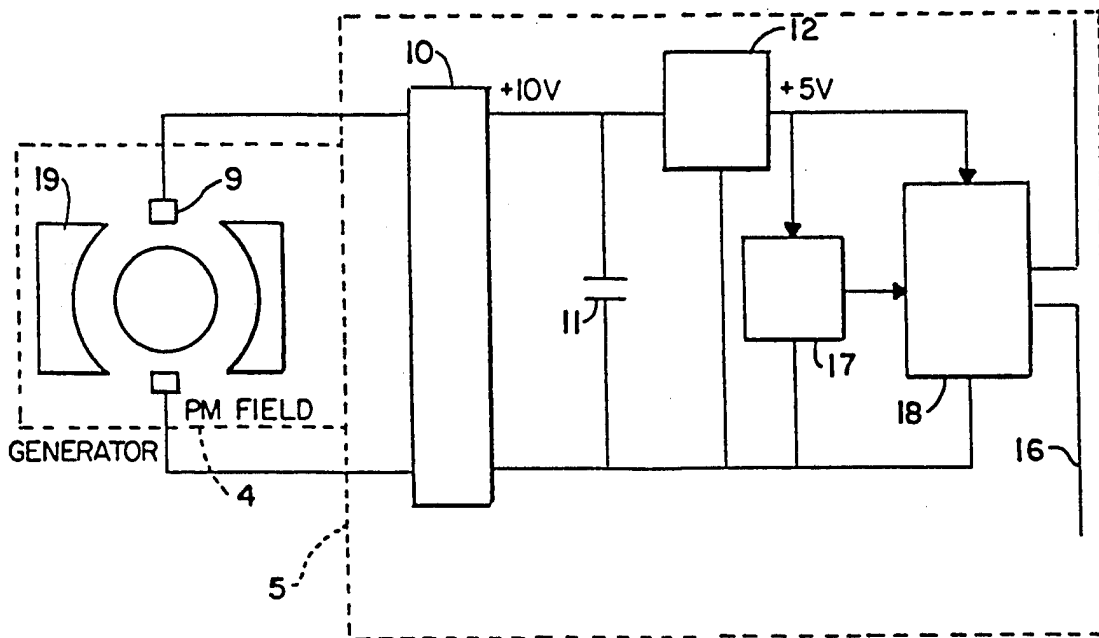

FIG. 2

Figure A-1. Patent. (Continued)

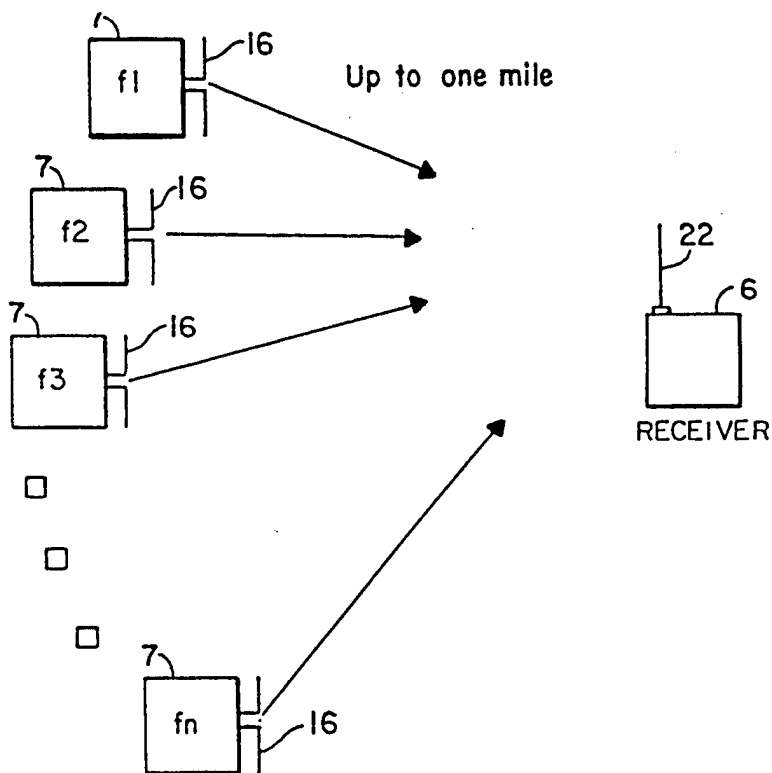

FIG. 3

Figure A-1. Patent.(Continued)

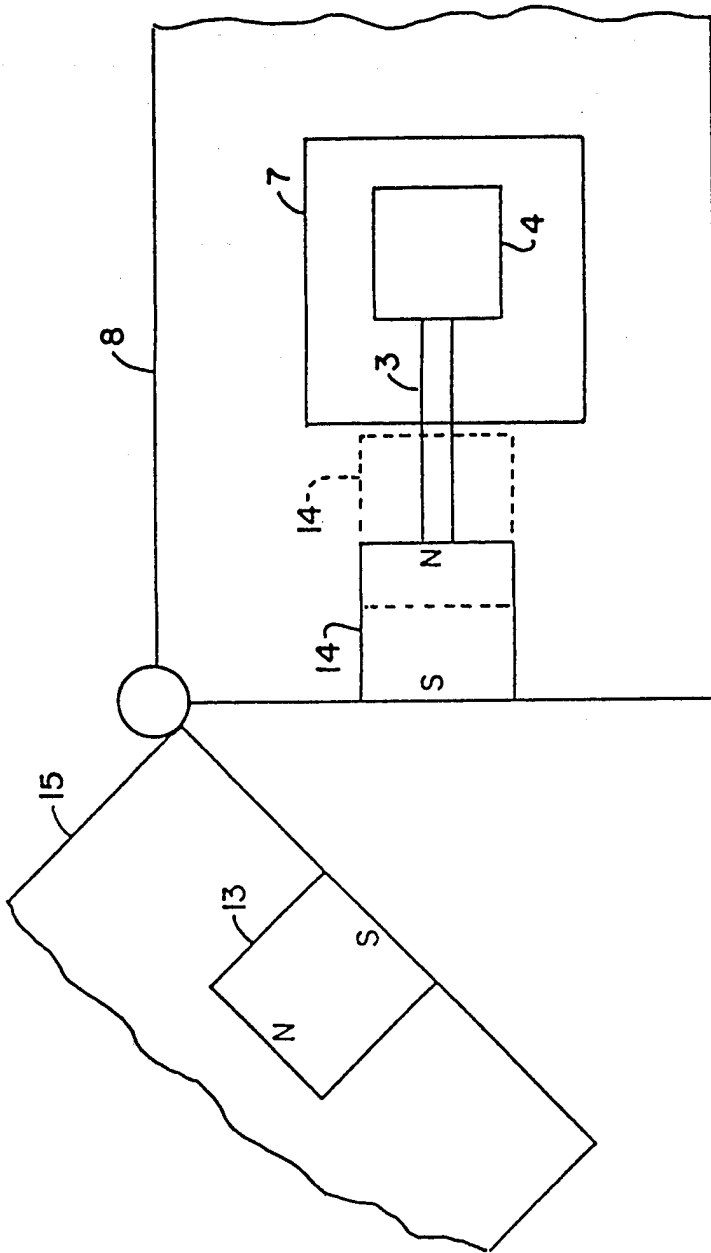

FIG. 4

Figure A-1. Patent. (Continued)

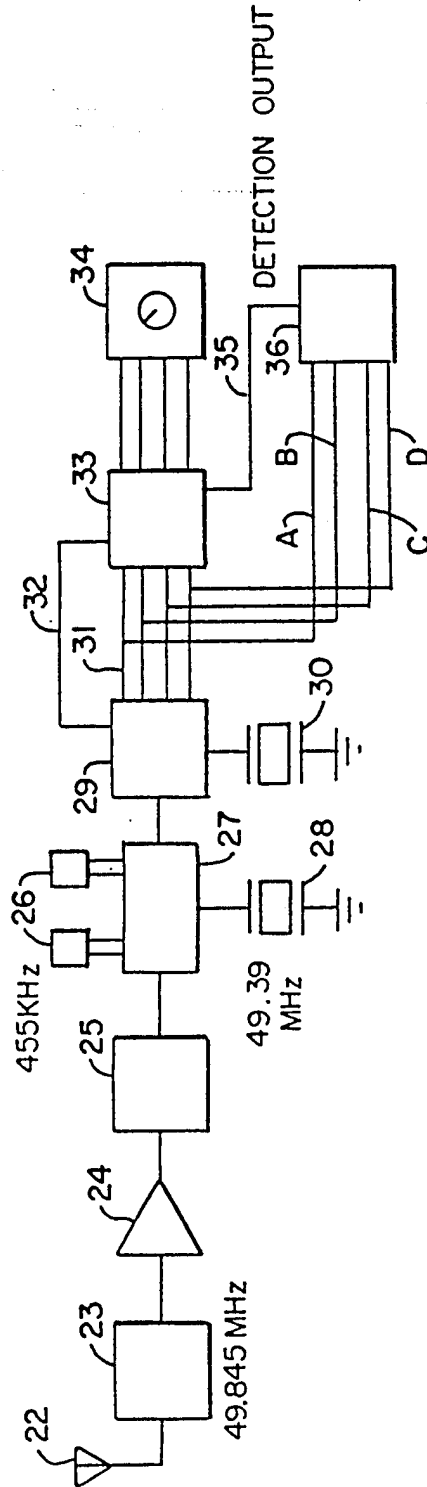

FIG. 5

Figure A-1. Patent. (Continued)

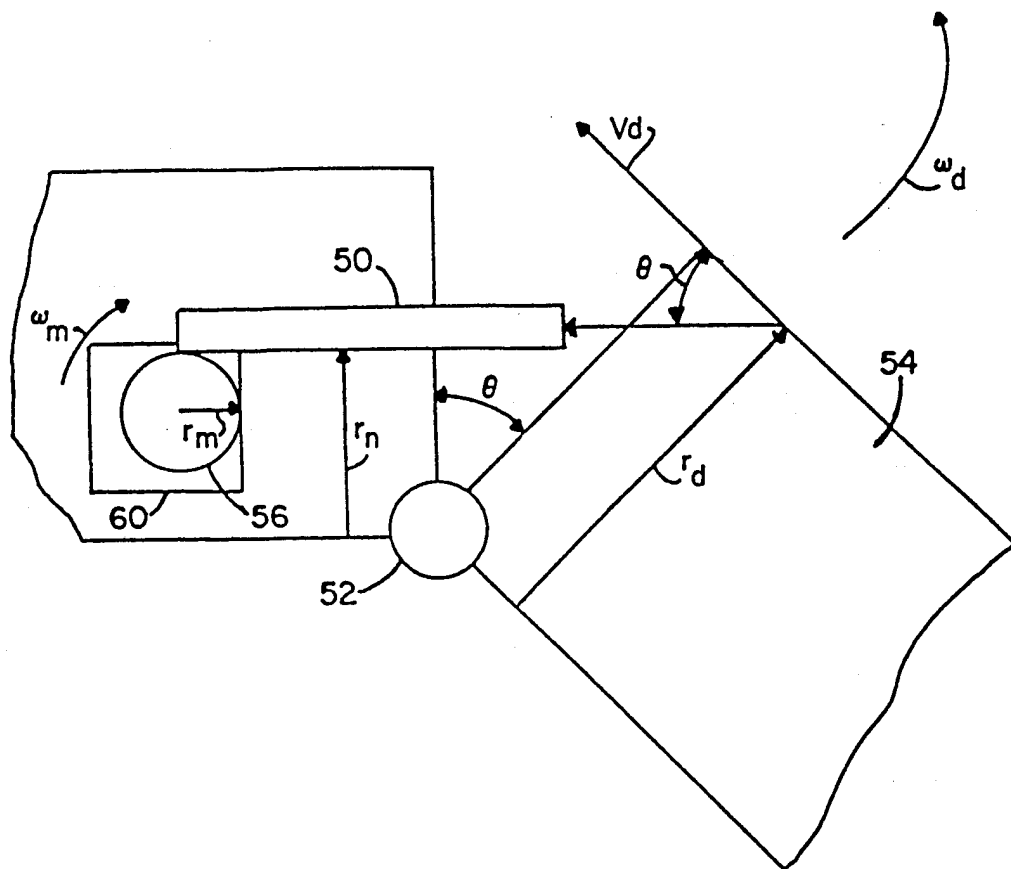

FIG. 6

Figure A-1. Patent.(Continued)

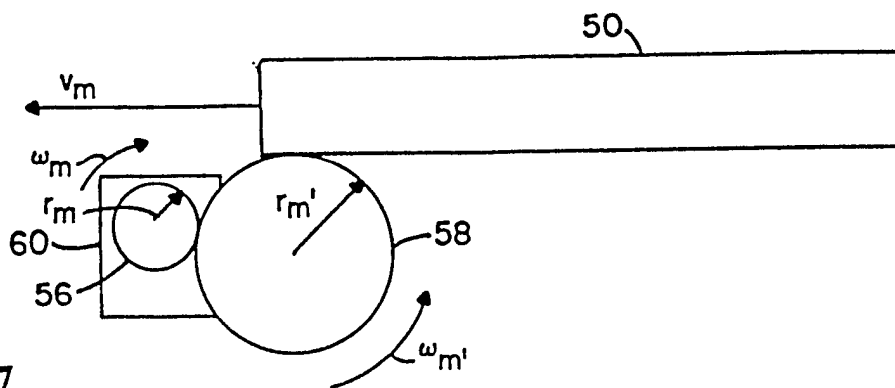

FIG. 7

Figure A-1. Patent.(Continued)

## BATTERYLESS SENSOR USED IN SECURITY APPLICATIONS

### DESCRIPTION OF THE PRIOR ART

#### 1. Field of the Invention

This invention relates to a batteryless and unattended sensor which can be used in security system applications to, for example, determine remotely, the opening/closing of a door or a window without the use of hard wiring.

#### 2. Description of Prior Art

The concept of a batteryless sensor was initially developed and patented for use as a vehicle traffic sensor [Reference 1]. The basic idea of the initial batteryless sensor is very simple. It consists of two opposing magnets mounted on iron pads and separated by a soft iron connecting rod. The rod serves as the core for a solenoid. When a ferromagnetic body, such as the under carriage of a vehicle, passes over the buried sensor a voltage,  $V$ , is produced by the solenoid in accordance with Faraday's Law. This law states that

$$V = N \frac{d\phi}{dt}$$

where  $N$  is the number of turns and  $d\phi$  the differential flux lines cut by the vehicle in a given time increment  $dt$ . The output voltage is an oscillatory transient of sufficient magnitude to power a VHF transmitter with an effective range of a few hundred feet. In the initial sensor, the radiated signal was produced when the amplitude of the signal was positive. The duration and amplitude of the oscillatory burst depended upon the speed and height of the vehicle. An oscillator using the output of the solenoid as an ersatz power supply ( $V_{cc}$ ) radiated a VHF signal to a traffic pole a few hundred feet away and then to a CPU for processing data. To be effective, however, the vehicle must be in motion over the sensor.

In the same year, a second member of the class of batteryless sensors was developed to monitor tire pressure on large trucks based on the energy available from a rotating wheel [Reference 2]. Large trucks contain as many as 32 very expensive tires. Tires wear very quickly when tire pressure is too low. Here, the EMF, necessary to power an oscillator source, is generated by a resonant mechanical system excited by cyclic accelerations of the tire. A switch attached to the tire fill valve closes when the tire pressure is less than a preset threshold. The VHF oscillator signal is radiated to a display in the cab which indicates when tire pressure is too low. This is also a safety feature.

In 1984, a third member of the class of batteryless sensors was developed for use by the Immigration and Naturalization Service (INS), Department of Justice [Reference 3]. There, the task was to detect the presence of illegal immigrants crossing certain sections of our border with Mexico.

Since people are not ferromagnetic targets, a new concept was necessary. The advantages of a batteryless sensor, as before, are that there is no maintenance or battery replacement costs and the possibility of theft of the sensor itself is minimized; installation costs are minimal.

For the INS application, a piezoelectric energy source was chosen. After a considerable amount of experimentation, it was found that an ordinary push

button igniter, similar to those in a commercial gas barbecue, could be mounted in a special set of hydraulic cylinders and used to generate sufficient energy to radiate a VHF signal to a remotely-located repeater. This Pascal cylinder arrangement is used to trade force for displacement, the equivalent of a mechanical transformer. Four pounds of force, as well as a  $\frac{1}{4}$  inch displacement, is required to trip the spring-loaded igniter. A human stepping on the sensor buried in sand four inches below the surface results in about 40 pounds of force applied to the igniter. The mechanical advantage provided by the Pascal cylinders is used to reduce the displacement in about the same proportion. These inexpensive sensors can be used to seed a preferred corridor of entry much like a mine field except here, a signal is radiated instead of an explosion.

The magnetic sensor placed in the roadway produces an EMF by changing the reluctance of the magnetic path. This, in turn, varies the flux lines passing through a solenoid generating the voltage required to power the VHF oscillator. The movement of the ferromagnetic automobile causes the generation action; the magnet and the solenoid are stationary.

In the batteryless low tire pressure sensor, the EMF is generated by a magnet mounted on a cantilever rod surrounded by a solenoid. Both the magnet and the solenoid rotate together with tire motion; only when there is acceleration (deceleration) is there a relative velocity between the magnet and the coil causing an EMF to be generated. This then powers a VHF oscillator which activates under low tire pressure.

For personnel detection, an EMF is generated by a piezoelectric transducer which is activated by an intruder's footprint. The format of this energy is a high voltage, short duration pulse (e.g., 30 kv and 50  $\mu$ s, respectively). Here, converting the signal to a conventional  $V_{cc}$  supply voltage with sufficient duration to operate a coded signal (e.g., 12 V and 20 ms respectively) is the task. The piezoelectric device and mounting structure remain fixed.

### OBJECTS OF THE INVENTION

An object of the subject invention is to create a batteryless energy source for converting either a rotational or a translational motion applied to the sensor into electrical energy sufficient to power a VHF oscillator.

It is another object of the invention to make the duration of the ersatz  $V_{cc}$  energy supply created by the motion sufficient to radiate a coded signal to a selective receiver located typically up to one mile distant from the sensor.

It is a further object to require no wiring to or from the sensor, and that the installation be covert in the sense that its presence is not obvious under general inspection.

### SUMMARY OF THE INVENTION

The above objectives and advantages are achieved in a preferred embodiment of the present invention. A small and concealed permanent magnet motor operated as a generator and when placed, in one example, in a door jamb is used to convert the rotational energy available from opening/closing a door or, in another example, the translational energy from opening/closing a window to an ersatz  $V_{cc}$  transient power supply via a pulley and spring arrangement; the regulated 10 volt supply has a duration of about 150 ms. The duration of

the power supply is sufficient to radiate a coded VHF oscillator signal to a repeater or central processing unit located as far as one mile from the sensor. The receiver is able to interrogate a multiplicity of sensor units over a given time period. It is shown how the covertness of the sensor can be further improved by using opposing magnets mounted both in the door and jamb.

DESCRIPTION OF THE DRAWINGS

- FIG. 1a shows a side view of a batteryless sensor.
- FIG. 1b shows a front view of the batteryless sensor.
- FIG. 2 shows an electronic block diagram of the preferred embodiment of the invention.
- FIG. 3 shows an array of coded sensors and a central receiver.
- FIG. 4 shows a covert permanent magnet approach for driving the permanent magnet generator of the batteryless sensor.
- FIG. 5 shows a micropower receiver block diagram.
- FIG. 6 is a vector representation of physical variables.
- FIG. 7 shows a step up gear arrangement.

DESCRIPTION OF THE PREFERRED EMBODIMENT

1. The Energy Source

In the batteryless sensor described in the subject invention, the intruder spins the armature of a small permanent magnet dc motor and gear train. Either the field or the magnets are moved relative to each other by the motion of the intrusion that generates the EMF. Translation energy here is converted to rotary motion and a pulley and a gear reduction scheme is used to provide the proper duration signal.

A dc motor, acting as a generator, converts motion to a transient electrical power supply. For example, the rotational energy of a door closure/opening motion is converted to the transient electrical power supply. In another example, the linear motion of a double hung window being opened is converted to the transient electrical power supply. The gear train spins the motor, which acts as the generator, at a high speed for a small linear displacement of a rod located in the frame of the door or window. One approach is to use a rack and pinion gear arrangement to convert the linear translation of a rod mounted in the door frame or window into a momentary rotational movement of the generator shaft. This was replaced in later models by a simple pulley and spring arrangement as the preferred mounting arrangement for the sensor. An analysis of the door/rod/pulley and gear train requirements will follow.

A typical example showing the invention is shown in FIGS. 1a and 1b. Referring to FIG. 1a, a batteryless sensor 7 is encased in a door jamb 8. When a plunger rod 3 is pushed in by the closing of a door 15, a timing belt 20 attached to the rod 3 by a collar 40 turns a pulley 1 which rotates a motor/generator 4. A spring 2 applies the proper tension to belt 20 to reset the rod 3 when the door 15 opens, again turning pulley 1 and rotating motor/generator 4 in the opposite direction. A stop collar 41 fastened to rod 3 is stopped by an inner surface of a container 42 to limit the motion of rod 3. A rubber grommet 43 cushions the rod 3 at the bottom. One end of spring 2 is anchored to a block 44, which is fastened to container 42.

In the front view of the sensor 7 shown in FIG. 1b, the motor/generator and gear train assembly 4 and

pulley 1 can be seen in conjunction with transmitter electronics 5 described in the next section. Subminiature componentry for sensor 7 is now commercially available to fit most window and door frames.

One embodiment of the subject invention uses a motor/generator and associated gear train 4 manufactured by Buehler Products, Inc., Raleigh, N.C., and identified as 18 V dc, part #1.61.01.347-5 068. The gear train accompanying the motor/generator 4 requires modification for this application. A number of intermediate spur gears are removed. A spacer is added so that the drive gear directly drives the gear that was previously at the end of the chain. In this manner, an approximately one inch displacement of the rod 3 mounted in the door jamb 8 turns the pulley 1 about 1/2 turn at a sufficient speed to generate about 10 volts across a 1k ohm load. With capacitor filtering, a pulse duration of 150 milliseconds (ms) is produced.

The total cost of all the components, including the motor/generator and gear train 4 and the electronics 5 is in the order of tens of dollars for the batteryless sensor 7; this does not include the cost of receiver 6 of FIG. 3, which is estimated in the range of hundreds of dollars.

2. The Integrated Sensor

An electronic block diagram of the preferred embodiment of the energy source 5 is shown in FIG. 2. Rod 3, belt 20 and pulley 1 turn the generator/gear train 4 shaft by making physical contact with the door 15 as shown in FIG. 1a. The resulting output of generator brushes 9, permanent magnet (PM) field 19 is applied to a DF02M, 1 ampere, 200-volt full-wave bridge rectifier 10 producing an unregulated 10 volt peak signal. A 100 µfd, 25 volt filter capacitor 11 and a 5 volt type 1078L05 regulator 12 provides an Ecc +5 volt supply, which is constant during the 150 ms pulse burst of VHF energy. The 5 volt V<sub>cc</sub> supply is connected to both a tone generator 17 (MX503 or 258TC) and a modulator and VHF oscillator 18 which feeds an essentially resonant dipole 16 (i.e., depending on length constraints in the door application). The signal radiated by the MC2833 oscillator chip 18 is set at 49.845 MHz and receives tones from tone generator 17 from 600 to 2,295 Hz. Four different tones were selected for experimentation and monitored by receiver 6. The MC2833 oscillator chip 18 is described on page 2-20 of the Motorola Telecommunications Catalogue, DL136 Revision 2, 1989.

In FIG. 2, the tone generator 17 supplies a sinusoidal tone frequency depending upon the digital code selected, as shown in Table I, as set by small switches D<sub>0</sub> through D<sub>3</sub>. One such switch setting is assigned to each batteryless/window sensor 7. In FIG. 3, a central receiver 6 distal to the sensors 7 receives the radiated signals.

TABLE I

Input Tone Frequencies (f <sub>0</sub> in Hz)*	Binary Coded Inputs			
	D <sub>3</sub>	D <sub>2</sub>	D <sub>1</sub>	D <sub>0</sub>
MX013QA				
600	0	0	0	0
741	0	0	0	1
882	0	0	1	0
1023	0	0	1	1
1164	0	1	0	0
1305	0	1	0	1
1446	0	1	1	0
1587	0	1	1	1
1728	1	0	0	0
1869	1	0	0	1

TABLE I-continued

Input Tone Frequencies (f <sub>0</sub> in Hz)*	Binary Coded Inputs			
	D <sub>3</sub>	D <sub>2</sub>	D <sub>1</sub>	D <sub>0</sub>
MX013QA				
2151	1	0	1	0
2435	1	0	1	1
2007	1	1	0	0
2295	1	1	0	1
459	1	1	1	0
NOTONE	1	1	1	1

\*Tolerance, ±20 Hz (Minimum)

The experimentally-measured current drains for the various components are as shown in Table II.

TABLE II

CURRENT DRAIN @ 5 VOLTS REGULATED.		
Component #	Component Type	Current (ma)
17	MX503	3
12	78L05	0.5
18	MC2833	3.0

The total current drain of the sensor, when activated, is 6.5 ma, corresponding to an actual load of 770 ohms, as compared to our original value of 750 ohms used in the initial testing of the V<sub>cc</sub> source. The chips for the RF modulator/oscillator 18 and tone generator 17 were selected to coordinate with the receiver 6 design. The frequency deviation of the FM transmission was measured to be 2500 Mz.

In FIG. 4 a more covert application suggests the use of two opposing magnets 13 and 14 in the door 15 and the door jamb 8 respectively. Then when the door 15 closes, the opposing magnets 13 and 14 would cause the rod 3 connected to one of the magnets 14 to drive the gear train 4 and, in turn, the generator 4 of sensor 7. The selection of magnets 13 and 14 and the cosmetic design of the door 15 and jamb 8 to facilitate this concept would be used where covertness is important.

FIG. 3 shows one receiver 6 monitoring a large number, f<sub>1</sub> through f<sub>n</sub>, of coded sensors 7. The dipole 16 transmits the coded rf signals to antenna 22 of receiver 6.

3. Primary Power Requirements

It can be shown that to achieve a range of one mile requires an effective radiated power of about 10 mW. Assuming the gain of the non-resonant dipole 16 of FIG. 2 (because of the extended length required) to be about unity, the dc primary power required for a measured 40 percent oscillator efficiency is about 25 mW. For a V<sub>cc</sub> of 5 volts, this corresponds to an equivalent load resistance of

$$R_L = \frac{(V_{cc})^2}{\text{Primary Power}} = \frac{25}{25 \times 10^{-3}} \sim 1k\Omega$$

Allowing for some power to operate the tone generator used for coding and modulator/transmitter 18, a R<sub>L</sub>=750 ohms was used for initial testing. For a rod 3 having a length of 1 inch and a 120 degree rotation of the shaft of the generator 4 in a half second, a signal duration of 150 ms is radiated; a minimum signal duration of 20 ms is required for successful detection.

4. The Receiver

A block diagram of the receiver 6 is provided in FIG. 5. The radiated VHF signal from the batteryless sensor

7 is received by antenna 22 and filtered by input band-pass filter 23. After amplification in low noise RF amplifier 24, the signal is further filtered by bandpass filter 25 in order to reduce the possibility of adjacent channel interference.

The filtered RF signal is then fed to a micropower RM receiver chip 27 (Motorola MC 3367) which consists of an internal downconverter (controlled by local oscillator crystal 28), IF amplifier, quadrature detector and lower power audio stages. Filtering is accomplished at the intermediate frequency (IF) of 456 kHz through the use of external resonators 26.

The audio output from the micropower receiver 27 is then passed to a tone decoder 29, an MX-COM MX-013 MetroPage™ decoder chip. A reference frequency for the tone decoder is generated by an internal oscillator controlled by external ceramic resonator 30. Upon receiving a narrowband FM, RF emission having the correct tone (FM modulation frequency), the decoder output 31 contains a four-bit digital word containing the ID of the signal, and Data Valid line 32 goes high to indicate that a valid tone has been received.

Hexadecimal switch 34 is used to select one of the 16 possible tone frequencies. If the output 31 from tone detector 29 matches the setting of switch 34, a logical one Detection Output signal 35 is generated by the comparator 33 to activate a monitor 36.

Receiver 6 power is obtained from a set of three (3) D-size lithium batteries (not shown). The entire receiver 6, as described above, draws approximately 2 mA at 3.6 Volts.

The batteryless sensor 7 being used operates on a spring-loaded pulley system which produces a voltage signal used to power a transmitter chip. It is important to determine the minimum rotational (angular) velocity required to cause the generator to produce some minimum supply voltage V<sub>s</sub>.

In FIG. 6, it can be seen that an applied rotational velocity, ω<sub>d</sub>, initiated by a door 54 closure/opening motion will translate to a certain related tangential velocity V<sub>m</sub> as follows:

$$V_d = \omega_d r_d$$

$$V_m = V_d \cos \theta = \omega_d r_d \cos \theta \tag{1}$$

At first it would appear that a generator's 60 velocity depends only on the angle θ of the door 54 opening. However, upon further examination, it can be shown that r<sub>d</sub>, the width of door 54, also varies with θ in a way that diminishes the dependence of the velocity on the angle of the door 54 opening. That is, since:

$$r_d = r_n \sec \theta, \tag{2}$$

it follows from (1) that

$$V_m = \omega_d r_n \sec \theta \cos \theta = \omega_d r_n. \tag{3}$$

Therefore, the relationship between the generator pulley's 56 rotational velocity (ω<sub>m</sub>) and the door's rotational velocity, ω<sub>d</sub>, is given by:

$$V_m = \omega_m r_m. \tag{4}$$

Then, by setting (3) equal to (4), the following ratio of rotational velocities is obtained:

$$\omega_m/\omega_d = r_n/r_m \quad (5)$$

This indicates that the generator's 60 velocity can be varied by changing the ratio of the pulley 56 and hinge 52 to rod and belt 50 radii. If enough rotational motion from the generator pulley 56 cannot be achieved, another step-up gear 58 can be added between the generator pulley 56 and rod and belt 50, as shown in FIG. 7. From the following relationships, the improvement that the step-up gear 58 will contribute can be found to be:

$$V_m = \omega_m r_m' = \omega_m r_m \quad (6)$$

and therefore,

$$\omega_m/\omega_m' = r_m'/r_m \quad (7)$$

Equation (7) indicates that for a given  $V_m$ , the rotational speed of the generator 60 can be increased directly by a factor of the ratio of the radii of the two gears 56 and 58.

While the invention has been shown and described with reference to the preferred embodiment thereof, it will be understood by those skilled in the art that the above and other changes in form and detail may be made therein without departing from the spirit and scope of the invention.

We claim:

1. A system including a number of batteryless sensors and a single receiver for detecting an intrusion at any one of said sensors, each of said sensors comprises:

- a sensor enclosure having an opening at atop end and a spring anchor at a bottom end;
- a rod positioned parallel to an intersection of two sides of said enclosure and having a top end protruding through said opening;
- a spring connected to said spring anchor;
- a pulley;
- a toothed belt having one end connected to said spring and another end connected to said rod at a bottom end in such a manner as to be wrapped around said pulley for a predetermined angle, said rod protruding through said opening a first predetermined distance under tension from said spring when said rod is in a first position, and said rod protruding through said opening a second predetermined distance under tension from said spring when said rod is being held in second position by a protected body,

generator means having said pulley positioned so that rotation of said pulley by said belt when said rod moves between said first position and said second position, and between said second position and said first position, generates a predetermined voltage; electronic means coupled to said generator means and responsive to said predetermined voltage for generating a coded rf signal identifying said sensor; said single receiver responsive to said coded rf signal from said any one of said sensors for signaling that said intrusion occurred and identifying a site of said intrusion.

2. The batteryless sensor of claim 1 wherein said generator means comprises:

- a gear train being driven by said pulley for amplifying the rotational speed of said pulley, and
- a motor/generator coupled to an output shaft of said gear train for generating said predetermined voltage.

3. The batteryless sensor of claim 2 wherein said electronic means comprises:

- a full-wave rectifier for receiving said predetermined voltage and producing an unregulated peak signal;
- a regulator for receiving said unregulated peak signal and producing a constant voltage for a predetermined time;
- a tone generator for receiving said constant voltage and producing a unique frequency signal to identify said sensor;
- an oscillator set for a fixed frequency is modified by said unique frequency to produce said coded rf signal when receiving said constant voltage; and
- a dipole for sending out said coded rf signal to said receiver.

4. A system for detecting an opening or a closing of a number of doors at one or more locations, each of said doors having a covert batteryless sensor, said system including a single receiver for indicating an opening or a closing of any one of said doors, each of said sensors comprises:

- a first magnet immovably mounted in a hinged side door edge with one pole face of said magnet flush with said door edge;
- a second magnet slideably mounted in a door jamb with an opposing pole face parallel to, facing and axial to said one pole face and flush with said door jamb when said door is ajar;
- plunger rod means axially fixed to said second magnet to allow said second magnet to be magnetically repelled by said first magnet so as to move axially a predetermined distance away from said first magnet when said door is closed, and move axially said predetermined distance towards said first magnet when said door is opened,

wherein said plunger rod means includes:

- a sensor enclosure having an opening at a top end;
- a rod positioned parallel to an intersection of two sides of said enclosure and having a top end protruding through said opening and securely fastened to said second magnet, said rod protruding through said opening so as to position said opposing pole face of said second magnet flush with said door jamb when said door is ajar, and to move a predetermined distance when said door is closed and said second magnet is repelled;

generator means coupled to said plunger rod means including means for following a movement of said predetermined distance, and including means for generating a coded rf signal upon detecting said movement; and

said single receiver being responsive to said coded rf signal from said any one of said sensors for signaling that said intrusion occurred and identifying a site of said intrusion.

5. The sensor of claim 4 wherein said follower means comprises:

- said enclosure having a spring anchor fastened at a bottom end;
- a spring connected to said spring anchor;
- a pulley;
- a toothed belt having one end connected to said spring and another end connected to said rod at a bottom end in such a manner as to be wrapped around said pulley for a predetermined angle so as to provide tension to said rod to maintain said opposing pole face of said second magnet flush to said

door jamb when said door is ajar, said pulley translating a linear distance traveled by said rod to a rotational angle when said door is opened and said second magnet is repelled.

6. The sensor of claim 5 wherein said generating means comprises:

- a gear train being drive by said pulley for amplifying the rotational speed of said pulley as said pulley rotates through said angle, and
- a motor/generator coupled to an output shaft of said gear train for generating said predetermined voltage.

7. A system including a number of batteryless sensors and a single receiver for detecting an intrusion at any one of said sensors, each of said sensors comprises:

- means for positioning a sensor in a location whereby said intrusion would effect a physical displacement of a medium;
- mechanical means for sensing said physical displacement, said mechanical means including:
  - a sensor enclosure having an opening at a top end;
  - a rod positioned parallel to an intersection of two sides of said enclosure and having a top end protruding through said opening to a first position, and said rod protruding through said opening to a second position, when said rod is being held by a protected body;
- generator means coupled to said mechanical means for converting said sensing of said physical displacement to a predetermined voltage;
- electronic means coupled to said generator means and responsive to said predetermined voltage for generating a coded rf signal identifying said sensor; said single receiver responsive to said coded rf signal from said any one of said sensors for signaling that said intrusion occurred and identifying a site of said intrusion.

8. The sensor of claim 7 wherein said generator means comprises:

- said enclosure having a spring anchor fastened at a bottom end;
- a spring connected to said spring anchor;
- a pulley;
- a toothed belt having one end connected to said spring and another end connected to said rod at a bottom end in such a manner as to be wrapped around said pulley for a predetermined angle so as to provide tension to said rod to maintain said rod in said first position, said pulley translating a linear distance traveled by said rod from said first position to said second position to a rotational angle;
- a gear train being driven by said pulley for amplifying the rotational speed of said pulley as said pulley rotates through said angle, and

a motor/generator coupled to an output shaft of said gear train for generating said predetermined voltage.

9. A system for detecting an opening or a closing of a number of windows at one or more locations, each of said windows having a covert batteryless sensor, said system including a single receiver for indicating an opening or a closing of any one of said windows, each of said sensors comprises:

- a first magnet immovable mounted in a window frame with one pole face of said magnet flush to said window frame edge;
- a second magnet slideably mounted in a corresponding side of said window with its opposing pole face parallel to, facing and axial to said one pole face;
- spring means axially fixed to said second magnet to allow said opposing pole face to move axially a predetermined distance toward said one pole face when said window is in a first position, and move axially said predetermined distance away from said one pole face when said window is in a second position,

wherein said spring means includes a rod axially fastened to said second magnet at a top end and a toothed belt having one end connected to a spring and another end connected to said rod at a bottom end in such a manner as to be wrapped around a pulley for a predetermined angle so as to provide tension to said rod to maintain said opposing pole face of said second magnet flush to said door jamb when said door is ajar, said pulley translating a linear distance traveled by said rod to a rotational angle when said door is opened and said second magnet is repelled;

generator means including means for following a movement of said second magnet said predetermined distance, and including means for generating a coded rf signal upon detecting said movement; and

said receiver being responsive to said coded rf signal from said any one of said sensors for signaling that said intrusion occurred and identifying a site of said intrusion.

10. A method of detecting an intrusion by means of a batteryless sensor including the steps of:

- A. Installing the sensor at a location where the intrusion would generate a mechanical displacement;
- B. Mechanically sensing the mechanical displacement as a movement in a straight line;
- C. Converting said straight line movement to a rotational movement;
- D. Mechanically speeding up the rotational movement;
- E. Generating an output voltage;
- F. Converting the output voltage to a coded rf signal;
- G. Sensing the coded rf signal over the air;
- H. Receiving the coded rf signal at a remote site; and
- I. Identifying the intrusion source.

\* \* \* \* \*

60

65

## APPENDIX B

### MOTOR CONSTRUCTION AND USE

#### B.1 IRONLESS CORE MOTOR DESIGN.

Ironless core technology for DC motors was originally developed as a means of constructing small motors with high efficiencies, low mechanical time constants, and the ability to operate smoothly at very slow speeds. The distinguishing feature of ironless core motors is the lack of iron laminations on the armature around which the wires of conventional armatures are wound. Ironless core technology has the following advantages:

1. **Elimination of lamination-magnetic field interaction:** The interaction of the iron laminations and the magnetic field in conventional motors produces the low speed 'cogging' effect which is a problem in applications where smooth, low speed operation is important. This interaction also produces a resisting torque which decreases motor efficiency.
2. **Low Inductance:** Elimination of the armature iron also significantly reduces armature inductance, thus decreasing the amount of electrical noise produced by the motor.
3. **Low Armature Inertia:** The ironless core motor features an armature with a very small mass. This results in extremely low inertias, thus permitting rapid acceleration and deceleration.

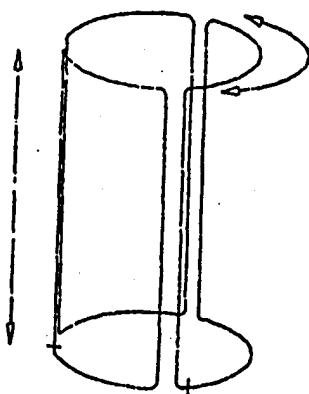

Figure B-1. Winding approach used in motors with iron core construction.

Figure B-1 illustrates the winding approach typically used in motors with iron core construction. A distinction is made between the sections of the armature conductors, which actively participate in producing torque, and the coil winding heads which merely connect the active armature conductors. The winding heads do not contribute to the production of torque but do add mass and ohmic resistance to the armature. When coil winding heads are arranged in several, superimposed layers (as is normally the case), even larger masses and ohmic resistances are involved.

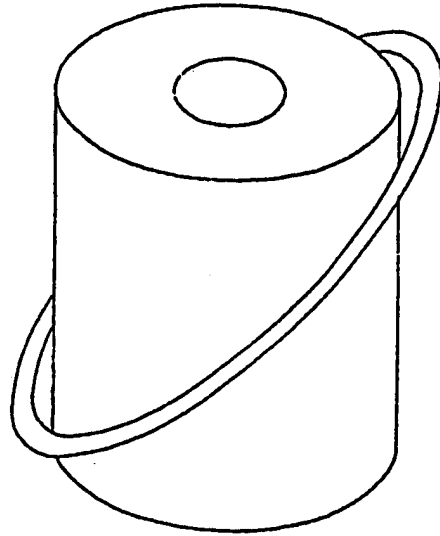

Figure B-2. Skew wound technique typically used in ironless core construction.

Figure B-2 illustrates the skew wound technique typically used in ironless core construction. In this case, all portions of the armature windings contribute to the production of torque. The symmetrical winding distribution also contributes to the smooth operation of the motor.

## B.2 DERIVATION OF THE BASIC MOTOR EQUATIONS.

For an ironless core, DC motor of relatively small size, the relationships which govern the behavior of the motor in various circumstances can be derived from physical laws and characteristics of the motors themselves.

Kirchoff's voltage rule states that "The sum of the potential increases in a circuit loop must equal the sum of the potential decreases." When applied to a DC motor connected in series with a DC power source, Kirchoff's voltage rule can be expressed as "The nominal supply voltage from the power source must be equal in magnitude to the sum of the voltage drop across the resistance of the armature windings and the back EMF generated by the motor."

$$V_0 = (I \times R) + V_e \quad (B.1)$$

Where:

- $V_0$  = power supply voltage in volts
- $I$  = current in the circuit in Amps
- $R$  = resistance of motor windings in Ohms
- $V_e$  = generated back EMF in volts

The back EMF generated by the motor is directly proportional to the angular velocity of the motor. The proportionality constant is the back EMF constant of the motor.

$$V_e = W \times K_e \quad (B.2)$$

Where:

W = angular velocity of the motor  
 K<sub>e</sub> = back EMF constant of the motor

Therefore, substituting equation (B.2) into equation (B.1):

$$V_0 = (I \times R) + (W \times K_e) \quad (B.3)$$

The back EMF constant of the motor is usually specified by the motor manufacturer in volts/RPM or mV/RPM. In order to arrive at a meaningful value for the back EMF, it is necessary to specify the motor velocity in units compatible with the specified back EMF constant.

The motor constant is a function of the coil design and the strength and direction of the flux lines in the air gap. Although it can be shown that the three motor constants normally specified (back EMF constant, torque constant, and velocity constant) are equal if the proper units are used, calculation is facilitated by the specification of three constants in the commonly accepted units.

The torque produced by the rotor is directly proportional to the current in the armature windings - the proportionality constant is the torque constant of the motor.

$$T = I \times K_T \quad (B.4)$$

Where:

T = torque developed at rotor  
 K<sub>t</sub> = motor torque constant

Substituting this relationship into Equation (B.3) produces:

$$V = (T \times R) / K_t + (W \times K_e) \quad (B.5)$$

The torque developed at the rotor is equal to the friction torque of the motor plus the resisting torque due to external mechanical loading:

$$T = T_f + T_l \quad (B.6)$$

Where:

T<sub>f</sub> = motor friction torque  
 T<sub>l</sub> = load torque

Assuming that a constant voltage is applied to the motor terminals, the motor velocity will be directly proportional to sum of the friction torque and the load torque. The constant of proportionality is the slope of the torque-speed curve, given by:

$$\text{Speed loss} = W_o/T_s \tag{B.7}$$

Where

$W_o$  = motor no-load speed

$T_s$  = motor stall torque

An alternative approach to deriving this value is to solve the earlier equation for velocity,  $W$ :

$$W = V_o/K_e - T_s R / (K_t \times K_e) \tag{B.8}$$

Differentiating both sides with respect to  $T_1$  yields:

$$dW/dT_1 = -R / (K_t \times K_e) \tag{B.9}$$

Using dimensional analysis to check units, the result is:

$$-\text{Ohms/oz-inA} \times (\text{V/RPM}) = -\text{Ohm-A-RPM/V-oz-in.} = -\text{RPM/oz-in}$$

which is a negative value describing loss of velocity as a function of increased torsional load.

### B.3 CALCULATING MECHANICAL POWER REQUIREMENTS.

Physically, power is defined as the rate of doing work. For linear motion, power is the product of force times distance per unit time. In the case of rotational motion, the analogous calculation for power is the product of torque times rotational distance per unit time.

$$P_{\text{rot}} = (T \times W) \tag{B.10}$$

$$T_m = (R \times J_m) / (K_e \times K_t) \tag{B.11}$$

Where:

$T_m$  = mechanical time constant

For the motor load system (assuming a purely inertial load), the mechanical time constant is given by:

$$T_m = (R \times (J_m + J_1)) / (K_e + K_t) \tag{B.12}$$

## APPENDIX C

### THEORY OF THE MICROSTRIP PATCH ANTENNA, CAVITY MODEL, FOR USE ON A METAL DOOR

#### C.1 INTRODUCTION.

The electromagnetic field associated with a microstrip antenna may be estimated in much the same manner as those of a dipole antenna.<sup>1 2</sup> This is the type of antenna that can be used on a metal door in place of the doorknob, itself, which must be insulated from the metal door. For the patch antenna, we may regard the guiding structure as an open-circuited transmission line, that is a cavity, on which we compute first order currents neglecting radiation. The radiation field is then computed from the (known) first order currents in the antenna aperture.

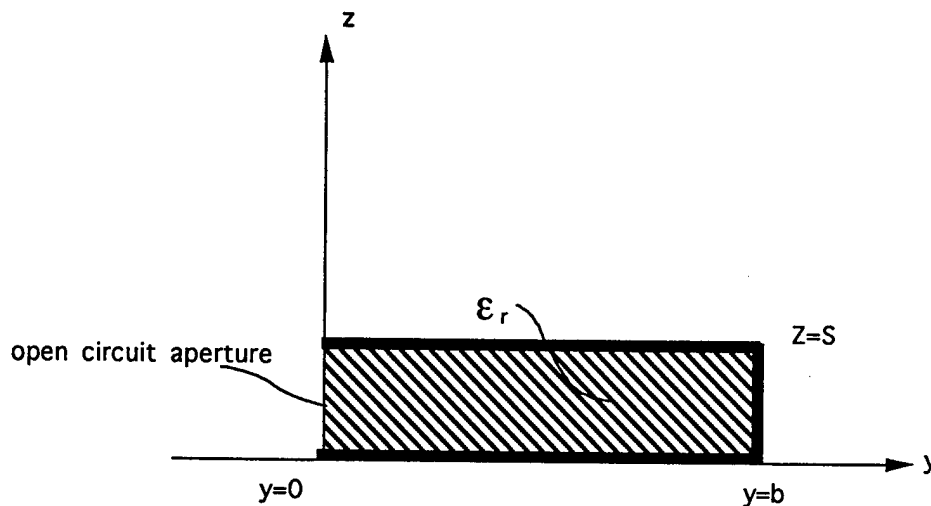

Figure C-1. Microstrip antenna cross-section.

The open circuit conditions in the aperture are enforced by closing this aperture with a perfect magnetic conductor on which tangential components of magnetic field and the normal component of electric field must vanish.

We now consider transverse magnetic (TM) with respect to the  $z$  direction modal fields. These may be derived from a scalar potential function  $\Phi_i(x,y)$  which satisfies

$$(\nabla_i^2 + k_{ci}^2)\Phi_i(x,y) = 0; \quad (C.1)$$

---

1 Y. T. Lo and S. W. Lee, *Antenna Handbook, Theory Applications and Design*, Van Nostrand Reinhold Company, New York, 1988.

2 J. R. James and P. S. Hall, eds., *Handbook of Microstrip Antennas*, Vols. 1 & 2, Peter Peregrinus Ltd., London, U.K., 1989.

subject to the boundary condition that

$$\Phi_i = \text{on electric conductor walls,}$$

$$\vec{\gamma}^0 \cdot \Phi_i = \text{on electric conductor walls,}$$

where  $\vec{\gamma}^0$  is the unit outward normal to the boundary.

For the rectangular geometry, we may verify that

$$\Phi_{mn}(x, y) = A_{mn} \sin\left(\frac{m\pi}{a}x\right) \cos\left(\frac{n\pi}{2b}y\right) \quad (C.2)$$

$$m = 1, 2, 3, \dots$$

$$n = 1, 3, 5, \dots$$

are modal solutions. Clearly,

$$\begin{aligned} \nabla_i^2 \Phi_{mn} &= \left( \frac{\partial^2}{\partial x^2} + \frac{\partial^2}{\partial y^2} \right) A_{mn} \sin\left(\frac{m\pi}{a}x\right) \cos\left(\frac{n\pi}{2b}y\right) \\ &= \left[ -\left(\frac{m\pi}{a}\right)^2 - \left(\frac{n\pi}{2b}\right)^2 \right] A_{mn} \sin\left(\frac{m\pi}{a}x\right) \cos\left(\frac{n\pi}{2b}y\right). \end{aligned} \quad (C.3)$$

and

$$\Phi_{mn}(x, b) = \Phi_{mn}(0, y) = \Phi_{mn}(a, y) = 0.$$

Now,

$$\nabla_i \Phi_{mn}(x, y) = A_{mn} \left[ \vec{x}^0 \left( \frac{m\pi}{a} \right) \cos\left(\frac{m\pi}{a}x\right) \cos\left(\frac{n\pi}{2b}y\right) - \vec{y}^0 \left( \frac{n\pi}{2b} \right) \sin\left(\frac{m\pi}{a}x\right) \sin\left(\frac{n\pi}{2b}y\right) \right] \quad (C.4)$$

and at the aperture,  $x = 0, \vec{\gamma}^0 = -\vec{y}^0$ .

$$-\vec{y}^0 \cdot \nabla_i \Phi_{mn}(0, y) = -\left(\frac{n\pi}{2b}\right) \sin\frac{m\pi}{a}x \sin\frac{n\pi}{2b}y \Big|_{x=0} = 0. \quad (C.5)$$

It follows that

$$k_{cmn}^2 = \left(\frac{m\pi}{a}\right)^2 + \left(\frac{n\pi}{2b}\right)^2 \quad (C.6)$$

The modal electromagnetic fields may now be written

$$\vec{E}_i(x, y, z) = V_{mn}(z) \vec{e}_{mn}(x, y)$$

$$\vec{H}_i(x, y, z) = I_{mn}(z) \vec{h}_{mn}(x, y)$$

where

$$\vec{e}_{mn}(x, y) = -\nabla_t \Phi_{mn}(x, y)$$

$$\vec{h}_{mn}(x, y) = \vec{z}^0 \times \vec{e}_{mn}(x, y).$$

From the Maxwell equation

$$\nabla \times \vec{H} = j\omega\epsilon\vec{E}$$

we obtain

$$\nabla \times \vec{H} \cdot \vec{z}^0 = \nabla \cdot (\vec{H} \times \vec{z}^0) = j\omega\epsilon\vec{E} \cdot \vec{z}^0$$

or

$$(\nabla_t \cdot \vec{H}_t \times \vec{z}^0) = \nabla_t \cdot I_{mn}(z) \vec{e}_{mn}(x, y)$$

$$= I_{mn}(z) \nabla_t^2 \Phi_{mn}(x, y) = I_{mn}(z) k_{cmm}^2 \Phi_{mn}(x, y) = j\omega\epsilon E_z.$$

Finally,

$$E_z(x, y, z) = I_{mn}(z) k_{cmm}^2 A_{mn} \sin\left(\frac{m\pi}{a}x\right) \cos\left(\frac{n\pi}{2b}y\right).$$

In general, the voltages  $V_{mn}(z)$  and currents  $I_{mn}(z)$  satisfy transmission line equations. However, if we assume that the spacing of the plates is small, then we may approximate  $I_{mn}(z)$  by a constant value  $I_{mno}$ . This is equivalent to setting the propagation constant in the  $z$  direction  $k_z \equiv 0$ . Since the total fields must satisfy the dispersion relation,

$$k^2 = k_{cmm}^2 + k_z^2,$$

fields in this thin patch cavity can exist only in the limit  $k_z \rightarrow 0$

$$\omega^2 \mu_0 \epsilon_r \epsilon_0 = k^2 = k_{cmm}^2$$

This is the resonance condition. When the cavity is isolated without losses, fields exist only at these resonant frequencies. The field pattern associated with the  $m=1, n=1$  mode is resonant at

$$2\pi \frac{f}{c} \sqrt{\epsilon_r} = \sqrt{\left(\frac{\pi}{a}\right)^2 + \left(\frac{\pi}{2b}\right)^2}.$$

When  $b = (2/3)a$ ,

$$fa = \frac{c}{2\sqrt{\epsilon_r}} \sqrt{1 + \left(\frac{3}{4}\right)^2}$$

$$\frac{0.18743 \times 10^9}{\sqrt{\epsilon_r}}.$$

This relation is plotted in Figure C-2 for  $\epsilon_r = 1.0, 2.0, 2.56$ .

Since  $k_z \rightarrow 0$ , the wave impedance at every plane,  $z = \text{constant}$ , is the same as at the boundaries, i.e.,  $Z(z) \rightarrow 0$ . Thus, for finite  $I_{mno}$  the corresponding  $V_{mno} \rightarrow 0$ ; the electric fields in the transverse plane  $E_x = E_y \rightarrow 0$ . The magnetic fields are

$$\begin{aligned} \vec{H}_1(x, y, z) &= I_{mno} \vec{h}_{mn}(x, y) = I_{mno} \vec{z} \times \vec{e}_{mn} \\ &= I_{mno} A_{mn} \left[ \vec{y}^0 \left( \frac{m\pi}{a} \right) \cos \left( \frac{m\pi}{a} x \right) \cos \left( \frac{n\pi}{2b} y \right) + \vec{x}^0 \left( \frac{n\pi}{2b} \right) \sin \left( \frac{m\pi}{a} x \right) \sin \left( \frac{m\pi}{2b} y \right) \right]. \end{aligned}$$

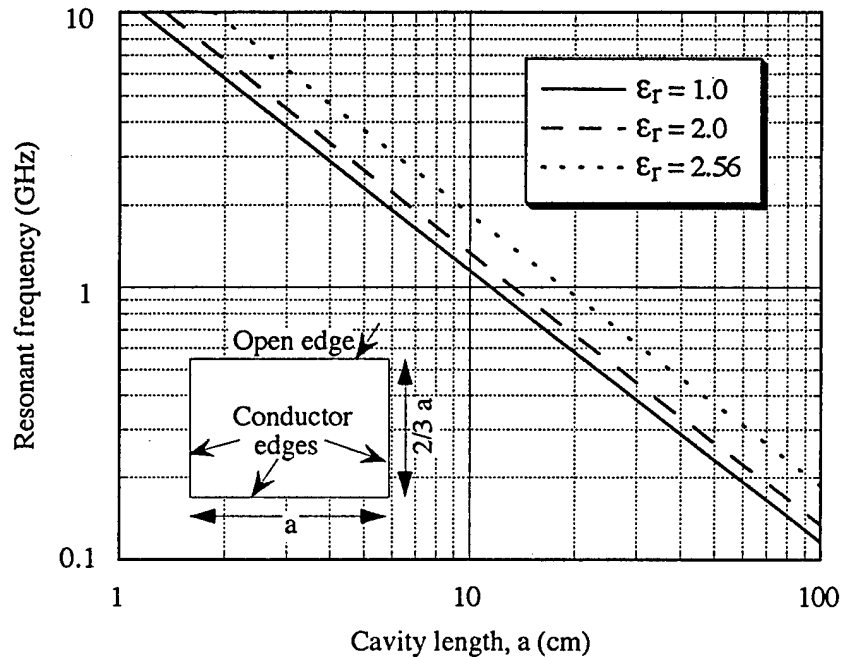

Figure C-2. Resonant frequency.

When coupling and radiation (losses) are taken into account, the cavity has finite  $Q$  (bandwidth).

## C.2 RADIATION.

The (magnetic) surface currents density which would need to flow on a hypothetical magnetic conductor to confine the cavity field is

$$\begin{aligned} \vec{J}_{ms} &= \vec{\gamma}^0 \times \vec{E} \text{ (at guide wall)} \\ &= -\vec{y}^0 \times \vec{z}^0 E_z(x, 0+, z) \\ &= -\vec{x}^0 E_z(x, 0+, z) \quad \frac{\text{Volts}}{\text{meter}}. \end{aligned}$$

In fact, no magnetic conductor is present and the actual field, just outside the antenna patch, is approximately (within the validity of the cavity mode) just the field inside the patch. Absent all other causes, this field is produced by precisely the negative of the above magnetic current. Consequently, we may derive the radiation field from just this magnetic current. Integrating over the gap dimension  $s$ , we find a source magnetic current<sup>3</sup>

$$V(x) = s \vec{J}_{ms} \cdot \hat{z} = s E_z(x, 0, z) = V_0 \sin \frac{\pi}{a} x.$$

We may regard this magnetic current (volts) as the Babinet dual of the electric current (amperes) associated with a half-wave electric dipole. The radiation pattern is, therefore,

$$\frac{1}{2} \sqrt{\frac{\epsilon_0 |V_0|^2}{\mu_0 8\pi^2}} \left[ \frac{\cos\left(\frac{\pi}{2} \sin \theta\right)}{(\cos \theta)} \right]^2 \quad (\text{watts/steradian}).$$

When this is integrated over the sphere, the result is

$$P_{RAD} = \frac{1}{2} \sqrt{\frac{\epsilon_0 |V_0|^2}{\mu_0 8\pi^2}} \cdot 2\pi(1.22) \quad \text{watts.}$$

The average total energy stored in the cavity is

$$\begin{aligned} W &= 2W_E = \int_0^s \int_0^a \int_0^b \epsilon_0 \epsilon_r |E_z|^2 dx dy dz \\ &= \int_0^s \int_0^a \int_0^b \left| \frac{V_0}{s} \right|^2 \sin^2 \frac{\pi}{a} x \cos^2 \frac{\pi}{2} y dx dy dz \\ &= \epsilon_0 \epsilon_r \frac{|V_0|^2 a}{s} \frac{b}{2} \left( \frac{1}{2} + \frac{1}{\pi} \right) \\ &= \epsilon_0 \epsilon_r \frac{|V_0|^2 a^2}{s} \left( \frac{1}{2} + \frac{1}{\pi} \right), \quad b = \frac{2}{3} a. \end{aligned}$$

We, therefore, obtain the radiation "Q",  $Q_{RAD}$

$$\frac{1}{Q_{RAD}} = \frac{P_{RAD}}{W 2\pi f_0} = 0.0283 \frac{s \lambda_0}{\epsilon_r a^2}$$

Evidently, the radiation Q for antennas scaled in proportion to wavelength is a constant (independent of frequency).

<sup>3</sup> The voltage  $sE_z = V(x)$  newly defined here is different from and not directly related to the quantities  $V_{mo}$  proportional to  $E_x, E_y$ .

### C.3 VARIATION OF INPUT IMPEDANCE.

We assume that the microstrip antenna is excited by probe coupled to a coaxial line or equivalent. The effect of positioning the probe may be accounted for by an ideal transformer in the input circuit. The transformer ratio is

$$n = \sin \frac{\pi}{a} x \cos \frac{\pi}{2b} y.$$

Consequently,

$$Z_{in}(x, y) = n^2 Z_{in} \left( \frac{a}{2}, 0 \right).$$

This offers a simple means for adjusting the coupling of the antenna to the input transmission line.

## DISTRIBUTION LIST

DNA-TR-95-21

### DEPARTMENT OF DEFENSE

DEFENSE INTELLIGENCE AGENCY  
ATTN: DIW-4

DEFENSE NUCLEAR AGENCY  
3 CY ATTN: NOSA  
ATTN: OPNA  
ATTN: OPNO  
2 CY ATTN: SSTL

DEFENSE TECHNICAL INFORMATION CENTER  
2 CY ATTN: DTIC/OCF

OASD (C3I)  
ATTN: ODASD I&S

OFFICE OF THE SECRETARY OF DEFENSE  
ATTN: DNA OATSD LIASON OFFICE

U S CENTRAL COMMAND  
ATTN: CCJ3  
ATTN: CCPM

U S EUROPEAN COMMAND  
ATTN: ECJ5N

UNDER SECRETARY OF DEFENSE (ACQ)  
ATTN: ODDR&E/TS/LS

US NUCLEAR COMMAND & CONTROL  
ATTN: LT COL AL RIGGLE

### DEPARTMENT OF THE ARMY

ADVANCED RESEARCH PROJECT AGENCY  
ATTN: EAO  
ATTN: STO S FLANK

ARMY RESEARCH INSTITUTE  
ATTN: PERI-ZT

DEPARTMENT OF THE ARMY  
2 CY ATTN: DAMO-ODL-S

OFFICE OF THE CHIEF OF ENGINEER  
ATTN: CEMP-ET

U S ARMY BELVOIR RD&E CTR  
ATTN: AMSAT-I-WTP  
ATTN: SATBE-JIS  
ATTN: STRBE-N  
ATTN: STRBE-X

U S ARMY ELECTRONIC WARFARE LAB  
ATTN: DELEW-I-S

U S ARMY MILITARY POLICE SCHOOL  
ATTN: ATZN-MP-CD  
ATTN: ATZN-MP-DE  
ATTN: ATZN-MP-TB  
ATTN: ATZN-MP-TS

U S ARMY NUCLEAR & CHEMICAL AGENCY  
ATTN: MONA-SU

U S ARMY RESEARCH LABORATORY  
ATTN: AMSRL-HR  
ATTN: DR D HODGE  
ATTN: SLCHE-CC-LHD HARRAH

U S ARMY TRAINING AND DOCTRINE COMD  
ATTN: ATCD-N

USAS4A  
ATTN: AMXSY-CA

### DEPARTMENT OF THE NAVY

CNO (NO9N3)  
ATTN: CODE 24B

DAVID TAYLOR RESEARCH CENTER  
ATTN: CODE 1203

NAVAL FACILITIES ENG SERV CTR  
ATTN: ESC66

NSWC  
ATTN: CODE 2064 L D HEMBREE

OFFICE OF CHIEF NAVAL OPERATIONS  
ATTN: NO9N

SPACE & NAVAL WARFARE SYSTEMS CMD  
ATTN: PME-121-3

U S ATLANTIC COMMAND  
ATTN: J324

U S MARINE CORPS  
ATTN: POS-20  
ATTN: POS-30

### DEPARTMENT OF THE AIR FORCE

AIR FORCE MATERIEL COMMAND  
ATTN: AFMC/SP

DEPARTMENT OF THE AIR FORCE  
ATTN: AF/RDST

ELECTRONIC SYSTEMS DIV  
ATTN: AVJR

HQ ACC/SP  
ATTN: HQ ACC/SP

MILITARY AIRLIFT COMMAND AMC/SP  
ATTN: SP

PACAF/LGWSN  
ATTN: SP

TECHNICAL DIRECTOR (NWI)  
ATTN: NTSMS

U S AIR FORCE IN EUROPE/SP  
ATTN: USAFE/SPO  
ATTN: USAFE/SPP

**DNA-TR-95-21 (DL CONTINUED)**

**USAF/SP**

ATTN: USAF/SPO  
ATTN: USAF/SPP

**DEPARTMENT OF ENERGY**

ASSOCIATED UNIVERSITIES, INC  
ATTN: DOCUMENT CUSTODIAN

**DEPARTMENT OF ENERGY**

ATTN: DASMA DP-20  
ATTN: NN-513.4

**SANDIA NATIONAL LABORATORIES**

ATTN: DIV 5838  
ATTN: ORG 5806 J W KANE  
ATTN: ORG 5831  
ATTN: ORG 5861

**OTHER GOVERNMENT**

NATIONAL INSTITUTE OF STANDARDS & TECHNOLOGY  
ATTN: L ELAISON

**U S SECRET SERVICE**

ATTN: LIBRARY

**DEPARTMENT OF DEFENSE CONTRACTORS**

**ANRO ENGINEERING INC**

2 CY ATTN: G F ROSS  
2 CY ATTN: J D DELORENZO  
2 CY ATTN: L R CAIN  
2 CY ATTN: W K KAHN

**COMPUTER SCIENCE CORPORATION**

ATTN: R A SWANSON

**JAYCOR**

ATTN: CYRUS P KNOWLES

**KAMAN SCIENCES CORP**

ATTN: DASIAC

**KAMAN SCIENCES CORPORATION**

ATTN: DASIAC

**VITRO CORPORATION**

ATTN: THOMAS J WHITTLE