

NASA Contractor Report 3955

A Refined Shear Deformation Theory for the Analysis of Laminated Plates

J. N. Reddy

GRANT NAG1-459
JANUARY 1986

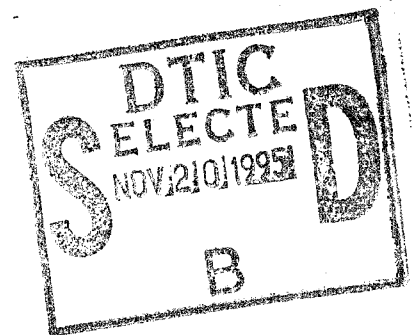

19951116 058

NASA
DEPARTMENT OF DEFENSE
PLASTICS TECHNICAL EVALUATION CENTER
HANSCOM, MASS, 01901

DTIC QUALITY INSPECTED B

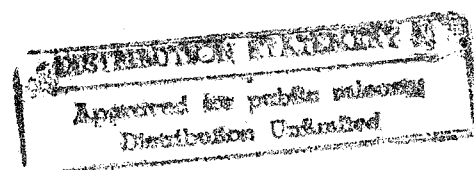

PLASTED 48759

-- 1 OF 1
-- ***DTIC DOES NOT HAVE THIS ITEM***
-- 1 - AD NUMBER: D43986E
-- 5 - CORPORATE AUTHOR: VIRGINIA POLYTECHNIC INST AND STATE UNIV
-- BLACKSBURG
-- 6 - UNCLASSIFIED TITLE: A REFINED SHEAR DEFORMATION THEORY FOR THE
-- ANALYSIS OF LAMINATED PLATES.
--10 - PERSONAL AUTHORS: REDD, J. N. J.
--11 - REPORT DATE: JAN 1986
--12 - PAGINATION: 38F
--14 - REPORT NUMBER: VPI-E-86, 26
--15 - CONTRACT NUMBER: NASH-45A
--16 - MONITOR ACRONYM: NASA
--17 - MONITOR SERIES: CR-3988
--20 - REPORT CLASSIFICATION: UNCLASSIFIED
--21 - LIMITATIONS (ALPHA): APPROVED FOR PUBLIC RELEASE; DISTRIBUTION
-- UNLIMITED. AVAILABLE FROM NATIONAL TECHNICAL INFORMATION SERVICE
-- SPRINGFIELD, VA 22161-4070
--23 - LIMITATION CODES: 1 ~~2~~

-- END Y FOR NEXT ACCESSION END

ALC-Z FOR HELP/ANSI 3 HDX 3 3 LOG CLOSED 3 PRINT OFF 3 PARITY

NASA Contractor Report 3955

A Refined Shear Deformation
Theory for the Analysis
of Laminated Plates

J. N. Reddy

*Virginia Polytechnic Institute and State University
Blacksburg, Virginia*

Prepared for
Langley Research Center
under Grant NAG1-459

NASA

National Aeronautics
and Space Administration

**Scientific and Technical
Information Branch**

1986

**A REFINED SHEAR DEFORMATION THEORY
FOR THE ANALYSIS OF LAMINATED PLATES**

J. N. Reddy
Department of Engineering Science and Mechanics
Virginia Polytechnic Institute and State University
Blacksburg, Virginia 24061 USA

ABSTRACT

A refined, third-order plate theory that accounts for the transverse shear deformation is presented, the Navier solutions are derived, and its finite element models are developed. The theory does not require the shear correction factors of the first-order shear deformation theory because the transverse shear stresses are represented parabolically in the present theory. A mixed finite element model that uses independent approximations of the displacements and moment resultants, and a displacement model that uses only displacements as degrees of freedom are developed. The mixed model uses C^0 elements for all variables and the displacement models use C^1 elements for the transverse deflection and C^0 elements for other displacements. Numerical results are presented to show the thickness effect on the deflections, and the accuracy of the present theory in predicting the transverse stresses. A comparison of the results obtained using the finite element models of the present theory with the experimental and the three-dimensional elasticity theory shows that the present theory is more accurate than the first-order shear deformation plate theory.

Accession For	
NTIS GRA&I	<input checked="" type="checkbox"/>
DTIC TAB	<input type="checkbox"/>
Unannounced	<input type="checkbox"/>
Justification	
<i>Unlimited Release</i>	
By <i>DTIC AF memo 2/10/95</i>	
Distribution/	
Availability Codes	
Dist	Avail and/or Special
<i>A-1</i>	

1. BACKGROUND: REVIEW OF THE LITERATURE

The classical laminate theory (CLT), which is an extension of the classical plate theory (CPT) to laminated plates, is inadequate for laminated plates made of advanced filamentary composite materials. This is because the effective elastic modulus to the effective shear modulus ratios are very large for such laminates. In addition, the classical plate theory is plagued with the inconsistency between the order of the differential equation and the number of boundary conditions (see Stoker [1]). An adequate description of the transverse shear stresses, especially near the edges, can be achieved with the use of a shear deformation theory.

The shear deformation plate theories known in the literature can be grouped into two classes: (1) stress-based theories, and (2) displacement-based theories. The first stress-based shear deformation plate theory is due to Reissner [2-4]. The theory is based on a linear distribution of the inplane normal and shear stresses through the thickness,

$$\begin{aligned}\sigma_1 &= \frac{M_1}{(h^2/6)} \frac{z}{(h/2)}, \quad \sigma_2 = \frac{M_2}{(h^2/6)} \frac{z}{(h/2)}, \\ \sigma_6 &= \frac{M_6}{(h^2/6)} \frac{z}{(h/2)}\end{aligned}\quad (1)$$

where (σ_1, σ_2) and σ_6 are the normal and shear stresses, (M_1, M_2) and M_6 are the associated bending moments (which are functions of the inplane coordinates x and y), z is the thickness coordinate and h is the total thickness of the plate. The distribution of the transverse normal and shear stresses $(\sigma_3, \sigma_4$ and $\sigma_5)$ is determined from the equilibrium equations of the three-dimensional elasticity theory. The differential

equations and the boundary conditions of the theory are obtained using Castigliano's theorem of Least Work.

The origin of displacement-based theories is apparently attributed to Basset [5], who begins his analysis with the assumption that the displacement components can be expanded in series of powers of the thickness coordinate z . For example, the displacement component u_1 along the x -direction in the N -th order theory is written in the form

$$u_1(x,y,z) = u(x,y) + \sum_{n=1}^N z^n \psi_x^{(n)}(x,y) \quad (2a)$$

where x and y are the Cartesian coordinates in the middle plane of the plate, and the functions $\psi_x^{(n)}$ have the meaning

$$\psi_x^{(n)}(x,y) = \left. \frac{d^n u_1}{dz^n} \right|_{z=0}, \quad n = 0, 1, 2, \dots \quad (2b)$$

Basset's work has not received as much attention as it deserves. In a 1949 NACA technical note, Hildebrand, Reissner and Thomas [6] presented (also see Hencky [7]) a first-order shear deformation theory for shells (which obviously can be specialized to flat plates). They assumed the following displacement field [a special case of Eq. (2a) for $N = 1$],

$$\begin{aligned} u_1(x,y,z) &= u(x,y) + z \psi_x(x,y) \\ u_2(x,y,z) &= v(x,y) + z \psi_y(x,y) \\ u_3(x,y,z) &= w(x,y) \end{aligned} \quad (3)$$

The differential equations of the theory are then derived using the principle of the minimum total potential energy. This gives five equilibrium equations in the five generalized displacement variables, u , v , w , ψ_x and ψ_y .

The shear deformation theory based on the displacement field in Eq. (3) for plates is often referred to as the Mindlin plate theory.

Mindlin [8] presented a dynamic analysis of Hencky's theory [7], and used the displacement field given by Eq. (3) for the vibration of isotropic plates. Historical evidence (from the review of the literature) points out that the basic idea of the displacement-based shear deformation theory came from Basset [5] and Hencky [7]. The shear deformation theory based on the displacement field given by Eq. (3) will be referred to as the first-order shear deformation theory.

Following these works, many extensions and applications of the two classes of theories were reported in the literature (see [9-35]). Gol'denveizer [16] has generalized Reissner's theory [2-4] by replacing the linear distribution of stresses through thickness [see Eq. (1)] by a distribution represented by an arbitrary function $\phi(z)$:

$$\sigma_1 = M_1\phi(z), \quad \sigma_2 = M_2\phi(z), \quad \sigma_6 = M_6\phi(z). \quad (4)$$

Kromm [14,15] presented a shear deformation theory that is a special case of Gol'denveizer's extension of Reissner's theory. In Kromm's theory, the function $\phi(z)$, instead of being arbitrary, is determined such that the transverse shear stresses vanish on the bounding planes of the plate. The displacement field in Kromm's theory is of the form

$$\begin{aligned} u_1 &= u - z \frac{\partial w}{\partial x} + \frac{3}{2} z \left(1 - \frac{4}{3} \frac{z^2}{h^2}\right) \psi_x \\ u_2 &= u - z \frac{\partial w}{\partial y} + \frac{3}{2} z \left(1 - \frac{4}{3} \frac{z^2}{h^2}\right) \psi_y \\ u_3 &= w \end{aligned} \quad (5)$$

where u , v , w , ψ_x and ψ_y are displacement functions which are functions of x and y only. Schmidt [29] presented an extension of Kromm's theory by accounting for moderately large deflections (i.e., in the von Karman sense).

Extension of the displacement-based theory to the moderately large deflections case is due to Medwadowski [17] and the extension to laminated plates is due to Whitney [23] and Whitney and Pagano [24].

The second- and higher-order displacement-based shear deformation theories have been investigated by Nelson and Lorch [27], Librescu [28] and Lo, Christensen and Wu [30]. These higher-order theories are cumbersome and computationally demanding because with each additional power of the thickness coordinate an additional dependent unknown is introduced (per displacement) into the theory.

Levinson [32] and Murthy [33] presented a third-order theory that assumes transverse inextensibility. The nine displacement functions were reduced to five by requiring that the transverse shear stresses vanish on the bounding planes of the plate. However, both authors (and also Schmidt [29]) used the equilibrium equations of the first-order theory in their analysis. As a consequence, the higher-order terms of the displacement field are accounted for only in the calculation of the strains but not in the governing differential equations or in the boundary conditions. Recently, Reddy [34,35] corrected these theories by deriving the governing differential equations by means of the virtual work principle. The theory presented in [34] accounts for moderately large rotations but is limited to orthotropic plates, while that in [35] is for the small-deflection theory of laminated plates. Finite element models of these theories were presented in [36,37]. The present report contains a summary of the research reported in references [34-37] on the development and analysis of a higher-order plate theory.

2. MATHEMATICAL FORMULATION OF A HIGHER-ORDER THEORY

Consider a rectangular laminate with planform dimensions a and b and thickness h as shown in Fig. 1. The coordinate system is taken such that the x - y plane coincides with the mid-plane of the plate, and the z -axis is perpendicular to that plane ($x_1 = x$, $x_2 = y$ and $x_3 = z$). The plate is composed of perfectly bonded orthotropic layers with the principal material axes of each layer oriented arbitrarily with respect to the plate axes.

2.1 Displacement Field

To obtain a parabolic distribution of the transverse shear stresses through the thickness, a cubic expansion in the thickness coordinate z [i.e., set $N=3$ in Eq. (2a)] is used for the inplane displacements and transverse inextensibility (i.e., the transverse normal strain ϵ_z is zero) is assumed. The additional displacement functions are determined in terms of the five displacement functions in Eq. (3) by requiring the transverse shear stresses to vanish at $z = \pm \frac{h}{2}$. The resulting displacement field is given by

$$\begin{aligned}u_1(x,y,z) &= u(x,y) + z\left[\psi_x(x,y) - \frac{4}{3}\left(\frac{z}{h}\right)^2\left(\psi_x(x,y) + \frac{\partial w}{\partial x}(x,y)\right)\right] \\u_2(x,y,z) &= v(x,y) + z\left[\psi_y(x,y) - \frac{4}{3}\left(\frac{z}{h}\right)^2\left(\psi_y(x,y) + \frac{\partial w}{\partial y}(x,y)\right)\right] \\u_3(x,y,z) &= w(x,y) \quad ,\end{aligned}\tag{6}$$

where u_1 , u_2 and u_3 are the displacements in the x -, y - and z -directions, respectively. The displacements of a point $(x,y,0)$ on the midplane of the plate are denoted by u , v and w ; ψ_x and ψ_y are the rotations of the normals to the midplane about the y - and x -axes, respectively. The assumed deformations of the transverse normals in

various plate bending (displacement based) theories are shown in Fig.

2.

The strains of the von Karman theory (i.e., only the products and squares of $\partial w/\partial x$ and $\partial w/\partial y$ in the strain-displacement equations of the large deflection theory are retained) can be obtained from Eq. (6):

$$\epsilon_1 = \epsilon_1^0 + z(\kappa_1^0 + z^2 \kappa_1^2), \quad \epsilon_2 = \epsilon_2^0 + z(\kappa_2^0 + z^2 \kappa_2^2), \quad (7)$$

$$\epsilon_4 = \epsilon_4^0 + z^2 \kappa_4^2, \quad \epsilon_5 = \epsilon_5^0 + z^2 \kappa_5^2, \quad \epsilon_6 = \epsilon_6^0 + z(\kappa_6^0 + z^2 \kappa_6^2)$$

where

$$\epsilon_1^0 = \frac{\partial u}{\partial x} + \frac{1}{2} \left(\frac{\partial w}{\partial x} \right)^2, \quad \kappa_1^0 = \frac{\partial \psi_x}{\partial x}, \quad \kappa_1^2 = -\frac{4}{3h^2} \left(\frac{\partial \psi_x}{\partial x} + \frac{\partial^2 w}{\partial x^2} \right)$$

$$\epsilon_2^0 = \frac{\partial v}{\partial y} + \frac{1}{2} \left(\frac{\partial w}{\partial y} \right)^2, \quad \kappa_2^0 = \frac{\partial \psi_y}{\partial y}, \quad \kappa_2^2 = -\frac{4}{3h^2} \left(\frac{\partial \psi_y}{\partial y} + \frac{\partial^2 w}{\partial y^2} \right)$$

$$\epsilon_4^0 = \psi_y + \frac{\partial w}{\partial y}, \quad \kappa_4^2 = -\frac{4}{h^2} \left(\psi_y + \frac{\partial w}{\partial y} \right) \quad (8)$$

$$\epsilon_5^0 = \psi_x + \frac{\partial w}{\partial x}, \quad \kappa_5^2 = -\frac{4}{h^2} \left(\psi_x + \frac{\partial w}{\partial x} \right)$$

$$\epsilon_6^0 = \frac{\partial u}{\partial y} + \frac{\partial v}{\partial x} + \frac{\partial w}{\partial x} \frac{\partial w}{\partial y}, \quad \kappa_6^0 = \frac{\partial \psi_x}{\partial y} + \frac{\partial \psi_y}{\partial x}, \quad \kappa_6^2 = -\frac{4}{3h^2} \left(\frac{\partial \psi_x}{\partial y} + \frac{\partial \psi_y}{\partial x} + 2 \frac{\partial^2 w}{\partial x \partial y} \right)$$

2.2 Stress Field

Assuming that each layer of the laminate possesses a plane of material symmetry parallel to the x-y plane, the constitutive equations for the k-th layer can be written as

$$\begin{Bmatrix} \bar{\sigma}_1 \\ \bar{\sigma}_2 \\ \bar{\sigma}_6 \end{Bmatrix}^{(k)} = \begin{bmatrix} \bar{Q}_{11} & \bar{Q}_{12} & 0 \\ \bar{Q}_{12} & \bar{Q}_{22} & 0 \\ 0 & 0 & \bar{Q}_{66} \end{bmatrix}^{(k)} \begin{Bmatrix} \bar{\epsilon}_1 \\ \bar{\epsilon}_2 \\ \bar{\epsilon}_6 \end{Bmatrix}^{(k)}, \quad (9a)$$

$$\begin{Bmatrix} \bar{\sigma}_4 \\ \bar{\sigma}_5 \end{Bmatrix}^{(k)} = \begin{bmatrix} \bar{Q}_{44} & 0 \\ 0 & \bar{Q}_{55} \end{bmatrix}^{(k)} \begin{Bmatrix} \bar{\epsilon}_4 \\ \bar{\epsilon}_5 \end{Bmatrix}^{(k)} \quad (9b)$$

where $\bar{\sigma}_i$ and $\bar{\epsilon}_i$ ($i = 1,2,4,5,6$) are the stress and strain components referred to lamina coordinates and \bar{Q}_{ij} 's are the plane-stress reduced elastic constants in the material axes of the k -th lamina,

$$\begin{aligned}\bar{Q}_{11} &= E_1/(1-\nu_{12}\nu_{21}), \quad \bar{Q}_{22} = \frac{E_2}{E_1} \bar{Q}_{11}, \quad \bar{Q}_{12} = \nu_{12}\bar{Q}_{22} \\ \bar{Q}_{44} &= G_{23}, \quad \bar{Q}_{55} = G_{13}, \quad \bar{Q}_{66} = G_{12}\end{aligned}\quad (10)$$

and E_i , ν_{ij} and G_{ij} are the usual engineering constants.

2.3 The Principle of Virtual Displacements: Governing Equations

The equations of equilibrium can be obtained using the principle of virtual displacements. In analytical form, the principle can be stated as follows (see [38]):

$$\int_{\Omega} (\delta U + \delta W) dV + \delta V = 0 \quad (11)$$

where U is the total strain energy density due to deformation, W is the potential of distributed external loads, V is the potential of discrete external loads, and Ω is the volume of the laminate and δ denotes the variational symbol. Integrating the expressions in Eq. (11) through the laminate thickness, integrating by parts with respect to x and y , and collecting the coefficients of δu , δv , δw , $\delta\psi_x$, and $\delta\psi_y$, the following equations of equilibrium are obtained:

$$\underline{\delta u}: \quad N_{1,x} + N_{6,y} = 0$$

$$\underline{\delta v}: \quad N_{6,x} + N_{2,y} = 0$$

$$\underline{\delta w}: \quad Q_{1,x} + Q_{2,y} - \frac{4}{h^2} (R_{1,x} + R_{2,y}) + \frac{4}{3h^2} (P_{1,xx} + 2P_{6,xy} + P_{2,yy}) = q$$

$$\frac{\delta \psi}{\delta x}: M_{1,x} + M_{6,y} - Q_1 + \frac{4}{h^2} R_1 - \frac{4}{3h^2} (P_{1,x} + P_{6,y}) = 0 \quad (12)$$

$$\frac{\delta \psi}{\delta y}: M_{6,x} + M_{2,y} - Q_2 + \frac{4}{h^2} R_2 - \frac{4}{3h^2} (P_{6,x} + P_{2,y}) = 0$$

where

$$(N_i, M_i, P_i) = \int_{-h/2}^{h/2} \sigma_i(1, z, z^3) dz \quad (i=1,2,6)$$

$$(Q_2, R_2) = \int_{-h/2}^{h/2} \sigma_4(1, z^2) dz \quad (13)$$

$$(Q_1, R_1) = \int_{-h/2}^{h/2} \sigma_5(1, z^2) dz$$

2.4 Laminate Constitutive Equations

The laminate constitutive equations are relations between the stress resultants (13) and the strains (7). Using Eqs. (7) in (9) and the result in Eq. (13), we obtain

$$\begin{Bmatrix} \{N_1\} \\ \{N_2\} \\ \{N_6\} \\ \{M_1\} \\ \{M_2\} \\ \{M_6\} \\ \{P_1\} \\ \{P_2\} \\ \{P_6\} \end{Bmatrix} = \begin{bmatrix} [A_{11} & A_{12} & A_{16}] \\ & [A_{22} & A_{26}] \\ \text{sym.} & & [A_{66}] \\ & & & [D_{11} & D_{12} & D_{16}] \\ & & & & [D_{22} & D_{26}] \\ & & & \text{sym.} & & [D_{66}] \\ & & & & & & [H_{11} & H_{12} & H_{16}] \\ & & & & & & & [H_{22} & H_{26}] \\ & & & & & & \text{sym.} & & [H_{66}] \end{bmatrix} \begin{Bmatrix} \{\epsilon_1^0\} \\ \{\epsilon_2^0\} \\ \{\epsilon_6^0\} \\ \{\kappa_1^0\} \\ \{\kappa_2^0\} \\ \{\kappa_6^0\} \\ \{\kappa_1^2\} \\ \{\kappa_2^2\} \\ \{\kappa_6^2\} \end{Bmatrix}$$

$$\begin{Bmatrix} Q_2 \\ Q_1 \\ R_2 \\ R_1 \end{Bmatrix} = \begin{bmatrix} A_{44} & A_{45} & D_{44} & D_{45} \\ & A_{55} & D_{45} & D_{55} \\ & & F_{44} & F_{45} \\ \text{sym.} & & & F_{55} \end{bmatrix} \begin{Bmatrix} \epsilon_4^0 \\ \epsilon_5^0 \\ \kappa_4^2 \\ \kappa_5^2 \end{Bmatrix} \quad (15)$$

where A_{ij} , B_{ij} , etc., are the laminate stiffnesses, defined by

$$(A_{ij}, B_{ij}, D_{ij}, E_{ij}, F_{ij}, H_{ij}) = \int_{-h/2}^{h/2} Q_{ij} (1, z, z^2, z^3, z^4, z^6) dz \quad (i, j=1, 2, 6)$$

$$(A_{ij}, D_{ij}, F_{ij}) = \int_{-h/2}^{h/2} Q_{ij} (1, z^2, z^4) dz \quad (i, j = 4, 5) \quad (16)$$

3. EXACT CLOSED-FORM SOLUTIONS

In the general case of arbitrary geometry, boundary conditions and lamination scheme, exact analytical solutions to the set of differential equations in Eq. (12) cannot be found. However, closed-form solutions for the static case exist for certain 'simply supported' rectangular plates with two sets of laminate stiffnesses (see Reddy [34,35]), as described below.

It is possible to obtain the Navier-type solutions for the following two types of simple supported boundary conditions.

$$\begin{aligned}
 \text{S-1:} \quad & u(x,0) = u(x,b) = v(0,y) = v(a,y) = 0 \\
 & N_2(x,0) = N_2(x,b) = N_1(0,y) = N_1(a,y) = 0
 \end{aligned} \tag{17a}$$

$$\begin{aligned}
 \text{S-2:} \quad & u(0,y) = u(a,y) = v(x,0) = v(x,b) = 0 \\
 & N_6(0,y) = N_6(a,y) = N_6(x,0) = N_6(x,b) = 0
 \end{aligned} \tag{17b}$$

$$\begin{aligned}
 & w(x,0) = w(x,b) = w(0,y) = w(a,y) = 0 \\
 \text{S-1} \quad & P_2(x,0) = P_2(x,b) = P_1(0,y) = P_1(a,y) = 0 \\
 \text{and :} \quad & \\
 \text{S-2} \quad & M_2(x,0) = M_2(x,b) = M_1(0,y) = M_1(a,y) = 0 \\
 & \psi_x(x,0) = \psi_x(x,b) = \psi_y(0,y) = \psi_y(a,y) = 0
 \end{aligned} \tag{17c}$$

Here a and b denote the planform dimensions along the x and y coordinates, respectively, and the origin of the coordinate system is taken at the lower left corner of the rectangular plate (see Fig. 1).

The Navier procedure involves expressing u , v , w , ψ_x , and ψ_y in terms of the Fourier series with undetermined coefficients. The functions in the series are selected such that they satisfy the boundary conditions of the plate. The coefficients are then determined by satisfying the equilibrium equation, Eq. (12).

Exact solutions can be obtained for rectangular plates with the combination of boundary conditions given in Eq. (17) and with the following zero plate stiffnesses [see Eqs. (14), (15) and (16)]:

For S-1 boundary conditions [Eqs. (17a) and (17c)]:

$$\begin{aligned}
 A_{16} &= A_{26} = B_{16} = B_{26} = D_{16} = D_{26} = 0 \\
 E_{16} &= E_{26} = F_{16} = F_{26} = H_{16} = H_{26} = 0 \\
 A_{45} &= D_{45} = F_{45} = 0
 \end{aligned}
 \tag{18a}$$

For S-2 boundary conditions [Eqs. (17b) and (17c)]:

$$\begin{aligned}
 A_{16} &= A_{26} = B_{11} = B_{12} = D_{16} = D_{26} = 0 \\
 E_{11} &= E_{12} = F_{16} = F_{26} = H_{16} = H_{26} = 0 \\
 A_{45} &= D_{45} = F_{45} = 0
 \end{aligned}
 \tag{18b}$$

The stiffnesses of the general cross-ply laminate satisfy Eq. (18a) while the stiffnesses of the antisymmetric angle-ply laminate satisfy Eq. (18b). A complete discussion of the exact solutions is presented in [38].

4. FINITE-ELEMENT MODELS

4.1 Displacement Model

Although the present higher-order theory has the same five generalized displacements as the first-order theory, second-order derivatives of the transverse deflection w appear in the total potential energy expression of the higher-order theory. An examination of the total potential energy functional of the higher-order theory reveals that u , v , w , ψ_n , ψ_s , and $\frac{\partial w}{\partial n}$ and $\frac{\partial w}{\partial s}$ appear in the geometric boundary conditions. Therefore, the finite element model based on the total potential energy requires the C^0 -continuity of u , v , ψ_x and ψ_y and the C^1 -continuity of w across interelement boundaries. Thus, the Lagrange interpolation of u , v , ψ_x and ψ_y , and the Hermite interpolation of w are required. Consequently, the classical plate bending (i.e., Hermite) element can be obtained as a special case from the present element by suppressing ψ_x and ψ_y degrees of freedom. In the present study, the four-node rectangular element with u , v , w , ψ_x , ψ_y , $\frac{\partial w}{\partial x}$ and $\frac{\partial w}{\partial y}$ as the nodal degrees of freedom is used.

The elemental equations of the displacement model are of the form (see [36])

$$[K^e]\{\Delta^e\} = \{F^e\} \quad (19)$$

where $\{\Delta^e\}$ denotes the vector of generalized nodal displacements and $\{F^e\}$ is the force vector that contains the applied transverse load as well as the contributions from the boundary of the element (see Reddy [39]).

4.2 Mixed Model

To relax the continuity requirements placed in the displacement model described above (i.e., to reduce the C^1 -continuity to the C^0 -

continuity on w), a mixed formulation of the problem is considered. In a mixed model, independent approximations of the displacements and stress resultants are used. A close look at Eq. (12) shows that a mixed variational formulation of these equations can be obtained by treating $u, v, w, \psi_x, \psi_y, M_1, M_2, M_6, P_1, P_2$ and P_6 as the nodal degrees of freedom. The governing equations for u, v, w, ψ_x and ψ_y are given in Eq. (12). The equations for the other six variables (M_1, M_2, M_6, P_1, P_2 and P_6) are provided by the laminate constitutive equations (14) and (15).

The mixed model is of the form (see [37])

$$[K^e]\{\Delta^e\} = \{F^e\} \quad (20)$$

where $[K^e]$, $\{\Delta^e\}$ and $\{F^e\}$ are the generalized element stiffness matrix, element displacement vector and element force vector, respectively.

5. NUMERICAL RESULTS

Numerical results obtained using the displacement and mixed finite element models described herein are presented for the bending of laminated anisotropic plates. Only representative results are included here. For additional results, see Refs. 34 thru 37.

In all the problems considered, the individual layers are taken to be of equal thickness, and only two sets of material properties are used (these values do not necessarily indicate the actual properties of any material, but they serve to perform parametric studies):

Material 1:

$$E_1/E_2=25, G_{12}/E_2=0.5, G_{23}/E_2=0.2, \nu_{12}=0.25 \quad (21)$$

Material 2:

$$E_1/E_2=40, G_{12}/E_2=0.6, G_{23}/E_2=0.5, \nu_{12}=0.25 \quad (22)$$

It is assumed that $G_{13} = G_{12}$, $\nu_{13} = \nu_{12}$. For the analysis based on the first-order shear deformation plate theory (FSPT), unless stated otherwise, the shear correction coefficients are taken to be

$$K_1^2 = K_2^2 = 5/6.$$

First, the (mixed) element was evaluated for its sensitivity to locking by using different integration rules. A two-layer, cross-ply [0/90], simply supported square plate under uniformly distributed transverse load was analyzed using the uniform 4x4 mesh of linear elements and 2x2 mesh of quadratic elements (in a quadrant), and various types of integration rules. Full integration refers to the usual integration rule (2x2 for the linear element and 3x3 for the quadratic element) for evaluating both bending and transverse shear terms of the stiffness matrix. Reduced integration refers to one point less (in each

coordinate direction) than that used in the usual integration scheme. Mixed (selective) integration refers to the use of the full integration rule for bending terms and the reduced integration rule for the shear terms. From the numerical results presented in Table 1, it is clear that full integration for very thick plates ($4 \leq \frac{a}{h} \leq 10$), mixed integration for moderately thick plates ($10 \leq \frac{a}{h} \leq 25$) and reduced integration for thin plates ($50 \leq \frac{a}{h}$) give the best results. Also, the quadratic element is less sensitive to integration rules than the linear element. In general, mixed integration gives the best results for the entire range of thicknesses.

5.1 Thickness Effect

The accuracy of the present higher-order theory over the first-order and classical plate theories is demonstrated using a specific problem. Consider a four-layer [0/90/90/0] square cross-ply laminated plate (Material 1) subjected to sinusoidally distributed transverse loading. The plate is simply supported along all four edges with the in-plane displacements, unconstrained in the normal direction, and constrained in the tangential direction. The deflections and stresses are non-dimensionalized as follows:

$$\begin{aligned}
 \bar{w} &= w\left(\frac{a}{2}, \frac{a}{2}, 0\right) \frac{100E_2h^3}{q_0a^4} \\
 \bar{\sigma}_1 &= \sigma_1\left(\frac{a}{2}, \frac{a}{2}, \frac{h}{2}\right) \frac{h^2}{q_0a^2} \\
 \bar{\sigma}_2 &= \sigma_2\left(\frac{a}{2}, \frac{a}{2}, \frac{h}{4}\right) \frac{h^2}{q_0a^2}, \\
 \bar{\sigma}_6 &= \sigma_6\left(0, 0, \frac{h}{2}\right) \frac{h^2}{q_0a^2}, \tag{23}
 \end{aligned}$$

$$\bar{\sigma}_5 = \sigma_5(0, \frac{a}{2}, 0) \frac{h}{q_0 a},$$

$$\bar{\sigma}_4 = \sigma_4(\frac{a}{2}, 0, 0) \frac{h}{q_0 a}$$

where q_0 denotes the intensity of the distributed transverse load, $q(x,y) = q_0 \sin \frac{\pi x}{a} \sin \frac{\pi y}{a}$. The exact maximum deflections obtained by various theories are compared for various side-to-thickness ratios in Fig. 3. The deflections predicted by the present higher-order shear deformation theory (HSDT) are in excellent agreement with the 3-D elasticity solutions of Pagano and Hatfield [40]. In the range of medium to thick plates ($5 \leq \frac{a}{h} \leq 20$), the HSDT yields more accurate results than the first-order shear deformation theory (FSDT). The effect of shear deformation on the deflections is apparent from the difference between the deflections predicted by the classical laminate theory (CLT) and the two shear deformation theories. The shear deformation causes a reduction in stiffness of composite plates and this reduction increases with decreasing side-to-thickness ratio. Clearly, the CLT is adequate in predicting the deflections of thin laminates ($a/h \geq 50$).

5.2 Through-the-Thickness Distribution of Transverse Shear Stresses

The exact stresses $\sigma_4 \equiv \sigma_{yz}$ and $\sigma_5 \equiv \sigma_{xz}$ computed using the constitutive equations of the HSDT are greatly improved over the results obtained using the CLT (classical laminate theory) and FSDT (first order shear deformation theory) as shown in Fig. 4a. The shear stresses obtained using the constitutive equations are on the low side of the 3-D elasticity solutions. This error might be due to the fact that the

stress continuity across each layer interface is not imposed in the present theory. As in the case of the classical laminate theory (CLT), the transverse shear stresses can also be determined by integrating equilibrium equations (of three-dimensional elasticity in the absence of body forces) with respect to the thickness coordinate:

$$\begin{aligned}\sigma_{xz} &= - \int_{-h/2}^{h/2} (\sigma_{x,x} + \sigma_{xy,y}) dz \\ \sigma_{yz} &= - \int_{-h/2}^{h/2} (\sigma_{xy,x} + \sigma_{y,y}) dz\end{aligned}\tag{24}$$

The foregoing approach not only gives single-valued shear stresses at the interfaces but yields excellent results for all theories in comparison with the three-dimensional solutions. Despite its apparent advantage, the use of stress equilibrium conditions in the analysis of laminated plates is quite cumbersome. Typical stress distributions of $\bar{\sigma}_5 = \bar{\sigma}_{xz}$ and $\bar{\sigma}_4 = \bar{\sigma}_{yz}$ through the thickness ($a/h = 10$) are shown in Fig. 4b. Note that the stress discontinuity at the laminate interfaces is due to the mismatch of the transformed material properties.

5.3 Relative Magnitudes of Transverse Stresses

The orders of magnitude of the stresses can be assessed by comparing the solutions of the higher-order theory with those of the three-dimensional theory of elasticity. To this end, an analytical solution is developed using the plate equations and boundary conditions in three dimensions following the procedure of Pagano [40]. The results, for specific problems, are shown in Tables 2 and 3.

The ratios of stresses in a simply supported square isotropic plate under sinusoidally (SDL) and uniformly (UDL) distributed transverse loads are given in Table 2. The number of terms used in the double-

TABLE 1 Effect of Reduced Integration and Type of Mesh on the Accuracy of the Solution* (Cross-Ply [0/90] Simply Supported Square Plate Under UDL; Material 1)

Type of Integration	$(\frac{a}{h})$	Type of Mesh**		$(\frac{a}{h})$	Type of Mesh	
		4x4L	2x2Q		4x4L	2x2Q
Full	4	3.0792	6.9705	20	1.4784	1.7479
Mixed		3.1045	3.0723		1.7475	1.7534
Reduced Sol.		3.1145	3.0769		1.7576	1.7548
Exact		3.0706	3.0706		1.7509	1.7509
Full	5	2.5728	2.5813	25	1.3261	1.7252
Mixed		2.5990	2.5808		1.7270	1.7334
Reduced		2.6090	2.5850		1.7371	1.7348
Exact Sol.		2.5791	2.5791		1.7310	1.7310
Full	10	1.8409	1.9192	100	0.2826	1.6789
Mixed		1.9185	1.9193		1.6927	1.7001
Reduced		1.9288	1.9218		1.7029	1.7014
Exact Sol.		1.9173	1.9173		1.6977	1.6977

* $\bar{w} = wE_2h^3 100/q_0a^4$.

** 4x4L = 4x4 uniform mesh of linear elements
 2x2Q = 2x2 uniform mesh of quadratic elements

TABLE 2 Stress Ratios in a Simply Supported Square Isotropic Plate Under Different Loadings (SSL-Sinusoidal Loading, UDL-Uniformly Distributed Loading) ($E = 10^6$ psi, $\nu = 0.3$, $q_0 = 1.0$ psi.)

$(\frac{a}{h})$	SSL		UDL ($m = n = 30$)	
	σ_z/σ_x	σ_{xz}/σ_{xy}	σ_z/σ_x	σ_{xz}/σ_{xy}
4	0.28740	0.53731	0.20363	0.58287
5	0.19069	0.43579	0.13338	0.47597
6.25	0.12478	0.35207	0.08667	0.38747
10	0.04989	0.22262	0.03443	0.24861
12.5	0.03210	0.17859	0.02212	0.20048
20	0.01261	0.11197	0.00868	0.12654
25	0.00808	0.08964	0.00556	0.10148
50	0.00202	0.04486	0.00139	0.05092
100	0.00051	0.02244	0.00035	0.02548

Note: $\sigma_x = \sigma_y$ and $\sigma_{xz} = \sigma_{yz}$
 $\sigma_x, \sigma_y, \sigma_z$ values are at $(x = y = \frac{a}{2}, z = \frac{h}{2})$
 σ_{xz} is at $(x = 0, y = \frac{a}{2}, z = 0)$
 σ_{yz} is at $(x = \frac{a}{2}, y = 0, z = 0)$
 σ_{xy} is at $(x = y = 0, z = \frac{h}{2})$

TABLE 3 Stresses in a 4-ply [0/90/90/0] Square Plate Under Sinusoidal Loading: Material 1 ($q_0 = 1.0$ psi.)

$(\frac{a}{h})$	σ_x	$-\sigma_y$	σ_z	σ_{xz}	$-\sigma_{yz}$	$-\sigma_{xy}$
4	11.524	45.240	1.0	0.8773	4.5975	0.8356
10	55.861	93.344	1.0	3.0137	4.8842	2.7503
20	217.13	256.74	1.0	6.5632	7.0610	9.2083
50	1348.3	1388.70	1.0	16.870	15.505	53.924
100	5388.5	5429.0	1.0	33.880	30.374	213.54

σ_x is at $(x = y = \frac{a}{2}, z = \frac{h}{2})$ σ_{xz} is at $(x = 0, y = \frac{a}{2}, z = 0)$
 σ_y is at $(x = y = \frac{a}{2}, z = -\frac{h}{2})$ σ_{yz} is at $(x = \frac{a}{2}, y = 0, z = -\frac{h}{2})$
 σ_z is at $(x = y = \frac{a}{2}, z = \frac{h}{2})$ σ_{xy} is at $(x = y = 0, z = \frac{h}{2})$

Fourier series, for the UDL case, is $m=n=30$, and for SDL, we take $m = n = 1$. It is clear that the ratio of normal stress σ_z to the inplane normal stresses σ_x and σ_y is very small (less than 5%) for moderately thick plates and very thin plates i.e., ($10 \leq \frac{a}{h} \leq 100$). However, the transverse shear stresses σ_{xz} and σ_{yz} are about 25% of the inplane shear stress, σ_{xy} , for moderately thick plates ($10 \leq \frac{a}{h} \leq 25$). In Table 3, similar results for a 4-ply [0/90/90/0] laminate are presented (Material 1 and sinusoidal loading); the same trend as described for isotropic plates is seen, confirming the fact that the transverse shear stresses should be considered before considering the transverse normal stress for moderately thick and thin plates.

5.4 Geometric Nonlinearity Effect

Next, the results of the von Karman (nonlinear) theory are presented. In Figures 5 and 6, the mixed finite element results of the higher-order theory are compared with the experimental and thin plate theory results of Zaghoul and Kennedy [41,42]. In Figure 5, center deflection versus the load intensity are presented for a simply supported, orthotropic, square plate ($a = b = 12$ in., $h = 0.138$ in.) under uniform loading. The material properties used are $E_1 = 3 \times 10^6$ psi, $E_2 = 1.28 \times 10^6$ psi, $G_{12} = G_{13} = G_{23} = 0.37 \times 10^6$ psi, $\nu = 0.32$. The finite element results are in excellent agreement with the experimental results. The thin plate theory results [41] are in considerable error, which can be attributed to the neglect of transverse shear deformations. In Figure 6, the center deflection of a clamped 4-ply symmetric bidirectional [0/90/90/0] square plate ($a = b = 12$ in, $h = 0.096$ in) under uniform loading is presented. The material properties used are: $E_1 = 1.8282 \times 10^6$ psi, $E_2 = 1.8315 \times 10^6$ psi, $G_{12} = G_{13} = G_{23} =$

.3125x10⁶ psi, $\nu = 0.23949$. The finite element results obtained using the higher-order theory are almost the same as those obtained using the first-order theory, and are in better agreement with the experimental results than those obtained using the classical theory. The difference between the experimental and higher-order theory solutions is attributed to inexact simulation of the experimental boundary conditions (clamped), which have significant effect on the deflections in composite laminates (because of the degree of orthotropy) than in homogeneous orthotropic plates.

6. SUMMARY AND CONCLUSIONS

A higher-(third-)order shear deformation theory is presented and its accuracy is demonstrated by comparing with the 3D elasticity theory, the classical plate theory and the first-order shear deformation theory. Mixed and displacement finite element models of the theory are described. The finite element solutions for nonlinear bending are compared with experimental solutions and found to be in good agreement.

The higher-order shear deformation theory gives, in general, more accurate solutions for the bending of laminated anisotropic plates than the classical plate theory and the first-order shear deformation theory. The present observations concerning the effects of shear deformation, and coupling and material anisotropy on the bending of plates are in conformity with other investigators' findings (see [23,24]). The first-order shear deformation theory (FSDT) is found to overpredict the deflections, and to underestimate the natural frequencies and buckling loads (results not included here) for medium to thick anti-symmetric cross-ply and angle-ply plates. In FSDT, the shear correction factors play a crucial role in the determination of deflections. No such corrections are required in the present higher-order theory. In addition, the finite element based either on the displacement formulation or the mixed formulation is less susceptible to locking than the element based on the displacement formulation of the first-order theory.

The present theory gives accurate through-the-thickness distribution of the interlaminar shear stresses but does not contain the transverse normal stress. It is possible to account for σ_z by expanding w as $w(x,y) = w_0(x,y) + z\psi_z(x,y)$, which would increase the number of nodal degrees of freedom by one. The discontinuity of the stresses (obtained using

constitutive equations) at layer interfaces can be eliminated by imposing continuity requirements, which might lead to a more complicated computational model.

Acknowledgements

The author acknowledges that the numerical results included in the report were obtained by Mr. Nam Phan and Dr. N. S. Putcha during their thesis work.

7. REFERENCES

- [1] Stoker, J. J.: "Mathematical problems connected with the bending and buckling of elastic plates." Bull. Amer. Math. Soc., Vol. 48, pp. 247-261, 1942.
- [2] Reissner, E.: "On the theory of bending of elastic plates." J. Math. Phys., Vol. 23, pp. 184-191, 1944.
- [3] Reissner, E.: "The effect of transverse shear deformation on the bending of elastic plates." J. Appl. Mech., Vol. 12, No. 1, pp. A-69 to A-77, 1945.
- [4] Reissner, E.: "On bending of elastic plates." Q. Appl. Math., Vol. 5, pp. 55-68, 1947.
- [5] Basset, A. B.: "On the extension and flexure of cylindrical and spherical thin elastic shells." Phil. Trans. Royal Soc., (London), Ser. A, Vol. 181, No. 6, pp. 433-480, 1890.
- [6] Hildebrand, F. B.; Reissner, E.; and Thomas, G. B.: "Notes on the foundations of the theory of small displacements of orthotropic shells." NACA Technical Note No. 1833, March 1949.
- [7] Hencky, H.: "Über die berücksichtigung der schubverzerrung in ebenen platten." Ing. Arch., Vol. 16, pp. 72-76, 1947.
- [8] Mindlin, R. D.: "Influence of rotatory inertia and shear on flexural motions of isotropic, elastic plates." J. Appl. Mech., Vol. 18, pp. 31-38, 1951.
- [9] Bolle, L.: "Contribution an probleme lineaire de flexion dune plaque elastique." Bull. Technique de la Suisse Romande, Parts 1 and 2, Vol. 73, pp. 281-285 and 293-298, 1947.
- [10] Reissner, E.: "Finite deflections of sandwich plates." J. Aero. Sci., Vol. 15, pp. 435-440, 1948.
- [11] Green, A. E.: "On Reissner's theory of bending of elastic plates." Q. Appl. Math., Vol. 7, No. 2, pp. 223-228, 1949.
- [12] Schäfer, V. M.: "Über eine verfeinerung der klassischen theorie dunner schwach gebogener platten." ZAMM, Vol. 32, No. 6, pp. 161-171, 1952.
- [13] Reissner, E.: "On variational theorem for finite elastic deformations." J. Math. Phys., Vol. 32, pp. 129-135, 1953.
- [14] Kromm, A.: "Verallgemeinerte Theorie der Plattenstatik." Ing. Arch., Vol. 21, pp. 266-286, 1953.
- [15] Kromm, A.: "Über die Randquerkräfte bei gestutzten Platten." ZAMM, Vol. 35, pp. 231-242, 1955.

- [16] Gol'denveizer, A. L.: "O teorii izgiba plastinok Reissnera (On Reissner's theory of the bending of plates)." *Izvestiya AN SSSR, OTN*, No. 4, pp. 102-109, 1958 (translation of the paper available as NASA Technical Translation F-27, May 1960).
- [17] Medwadowski, S. J.: "A refined theory of elastic, orthotropic plates." *J. Appl. Mech.*, Vol. 25, pp. 437-443, 1958.
- [18] Salerno, V. and Goldberg, M. A.: "Effect of shear deformations on the bending of rectangular plates." *J. Appl. Mech.*, Vol. 27, No. 1, pp. 54-58, 1960.
- [19] Volterra, E.: "Effect of shear deformations on bending of rectangular plates." (Discussion of Ref. [18]) *J. Appl. Mech.*, Vol. 27, No. 3, pp. 594-596, 1960.
- [20] Boal, J. L. and Reissner, E.: "Three-dimensional theory of elastic plates with transverse inextensibility." *J. Math. Phys.*, Vol. 39, pp. 161-181, 1960.
- [21] Ambartsumyan, S. A.: Theory of Anisotropic Shells, NASA Report TT F-118, 1964.
- [22] Yang, P. C.; Norris, C. H. and Stavsky, Y.: "Elastic wave propagation in heterogeneous plates." *Int. J. Solids and Struct.*, Vol. 2, No. 4, pp. 665-684, 1966.
- [23] Whitney, J. M.: "The effect of transverse shear deformation on the bending of laminated plates." *J. Comp. Materials*, Vol. 3, pp. 534-547, 1969.
- [24] Whitney, J. M. and Pagano, N. J.: "Shear deformation in heterogeneous anisotropic plates." *J. Appl. Mech.*, Vol. 37, pp. 1031-1036, 1970.
- [25] Reissner, E.: "A consistent treatment of transverse shear deformations in laminated anisotropic plates." *AIAA J.*, Vol. 10, No. 5, pp. 716-718, 1972.
- [26] Chou, P. C. and Carleone, J.: "Transverse shear in laminated plate theories." *AIAA J.*, Vol. 11, No. 9, pp. 1333-1336, 1973.
- [27] Nelson, R. B. and Lorch, D. R.: "A refined theory for laminated orthotropic plates." *J. Appl. Mech.*, Vol. 41, pp. 177-183, 1974.
- [28] Librescu, L.: Elastostatics and Kinetics of Anisotropic and Heterogeneous Shell-Type Structures, Noordhoff, The Netherlands, 1975.
- [29] Schmidt, R.: "A refined nonlinear theory of plates with transverse shear deformation." *J. Industrial Mathematics Society*, Vol. 27, Part 1, pp. 23-28, 1977.
- [30] Lo, K. H.; Christensen, R. M. and Wu, E. M.: "A high-order theory of plate deformation." Parts 1 and 2, *J. Appl. Mech.*, Vol. 44, pp. 663-676, 1977.

- [31] Reissner, E.: "Note on the effect of transverse shear deformation in laminated anisotropic plates." Comput. Meth. Appl. Mech. Engng., Vol. 20, No. 2, pp. 203-209, 1979.
- [32] Levinson, M.: "An accurate simple theory of the statics and dynamics of elastic plates." Mech. Res. Commun., Vol. 7, pp. 343-350, 1980.
- [33] Murthy, M. V. V.: "An improved transverse shear deformation theory for laminated anisotropic plates." NASA TP-1903, November 1981.
- [34] Reddy, J. N.: "A refined nonlinear theory of plates with transverse shear deformation." Int. J. Solids Struct., Vol. 20, No. 9/10, pp. 881-896, 1984.
- [35] Reddy, J. N.: "A simple higher-order theory for laminated composite plates." J. Appl. Mech., Vol. 51, pp. 745-752, 1984.
- [36] Phan, N. D.: "Linear Analysis of Laminated Composite Plates Using a Higher-Order Shear Deformation Theory." M.S. Thesis, Virginia Polytechnic Institute, Blacksburg, VA, USA, 1984.
- [37] Putcha, N. S.: "A Mixed Shear Flexible Finite Element for Geometrically Nonlinear Analysis of Laminated Plates." Ph.D. Thesis, Virginia Polytechnic Institute, Blacksburg, VA, USA, 1984.
- [38] Reddy, J. N.: Energy and Variational Methods in Applied Mechanics, John Wiley and Sons, Inc., New York, 1984.
- [39] Reddy, J. N.: An Introduction to the Finite Element Method, McGraw-Hill Book Co., Inc., New York, 1984.
- [40] Pagano, N. J. and Hatfield, S. J.: "Elastic behavior of multilayered bidirectional composites." AIAA J., Vol. 10, pp. 931-933, 1972.
- [41] Zaghoul, S. A. and Kennedy, J. B.: "Nonlinear behavior of symmetrically laminated plates." J. Appl. Mech., Vol. 42, pp. 234-236, 1975.
- [42] Zaghoul, S. A. and Kennedy, J. B.: "Nonlinear analysis of unsymmetrically laminated plates." J. Engng. Mech. Division, ASCE, Vol. 101, No. EM3, pp. 169-186, 1975.

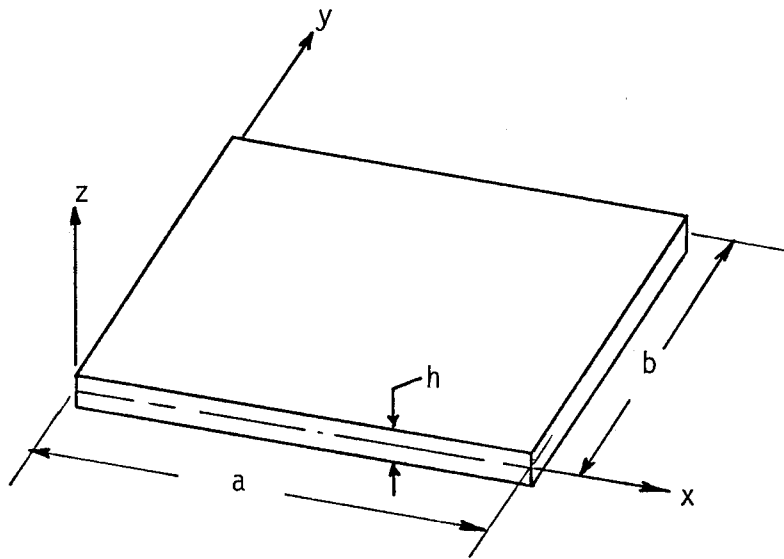
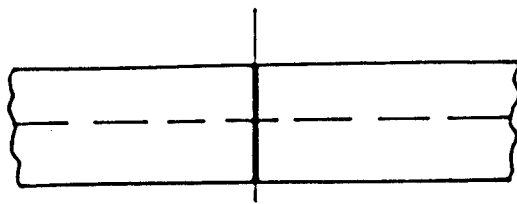
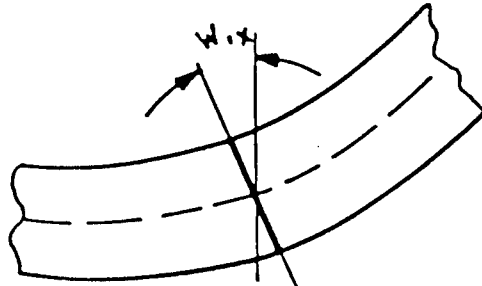

Figure 1. The geometry and the coordinate system for a rectangular plate.

Kinematics of various plate theories



UNDEFORMED



DEFORMED IN CLASSICAL
(KIRCHHOFF) THEORY

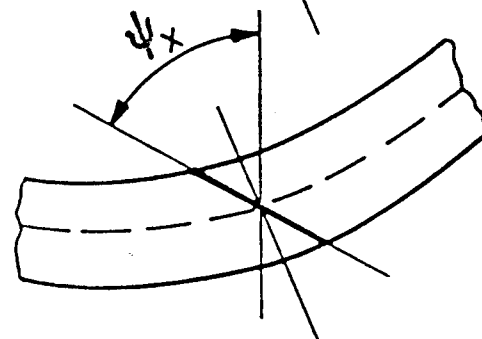

DEFORMED IN THE FIRST
ORDER THEORY

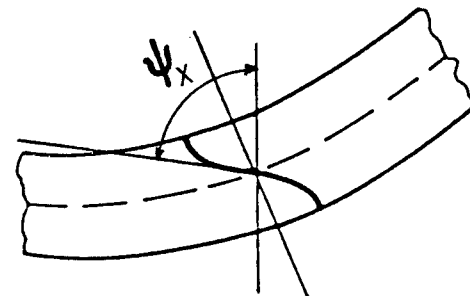

DEFORMED IN THE THIRD
ORDER (PRESENT) THEORY

Figure 2. Assumed deformation patterns of the transverse normals in various displacement-based theories.

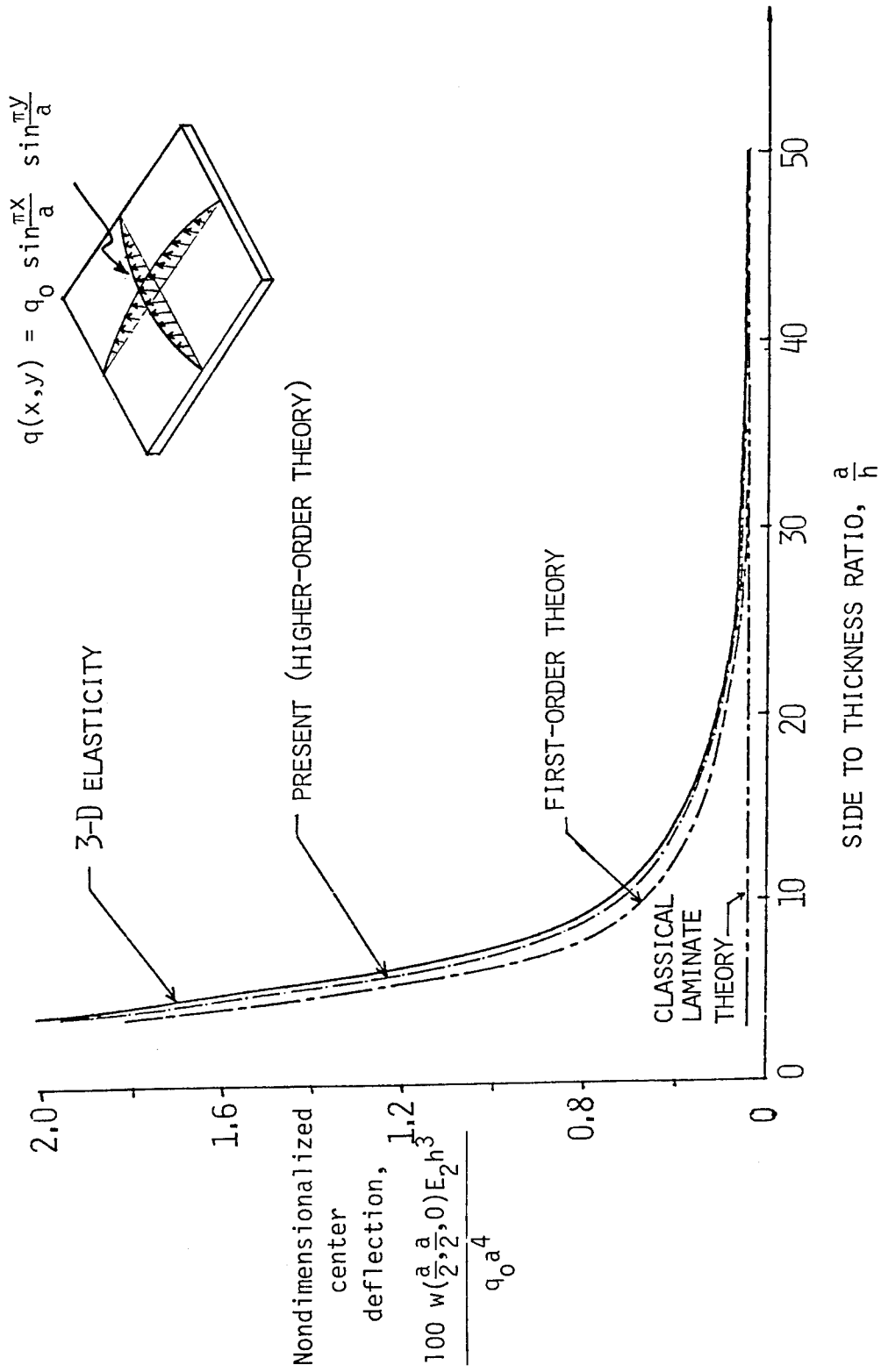

Figure 3. Nondimensionalized center deflection versus side to thickness ratio for four-layer, symmetric cross-ply [0 /90 /90 /0] square laminated plate.

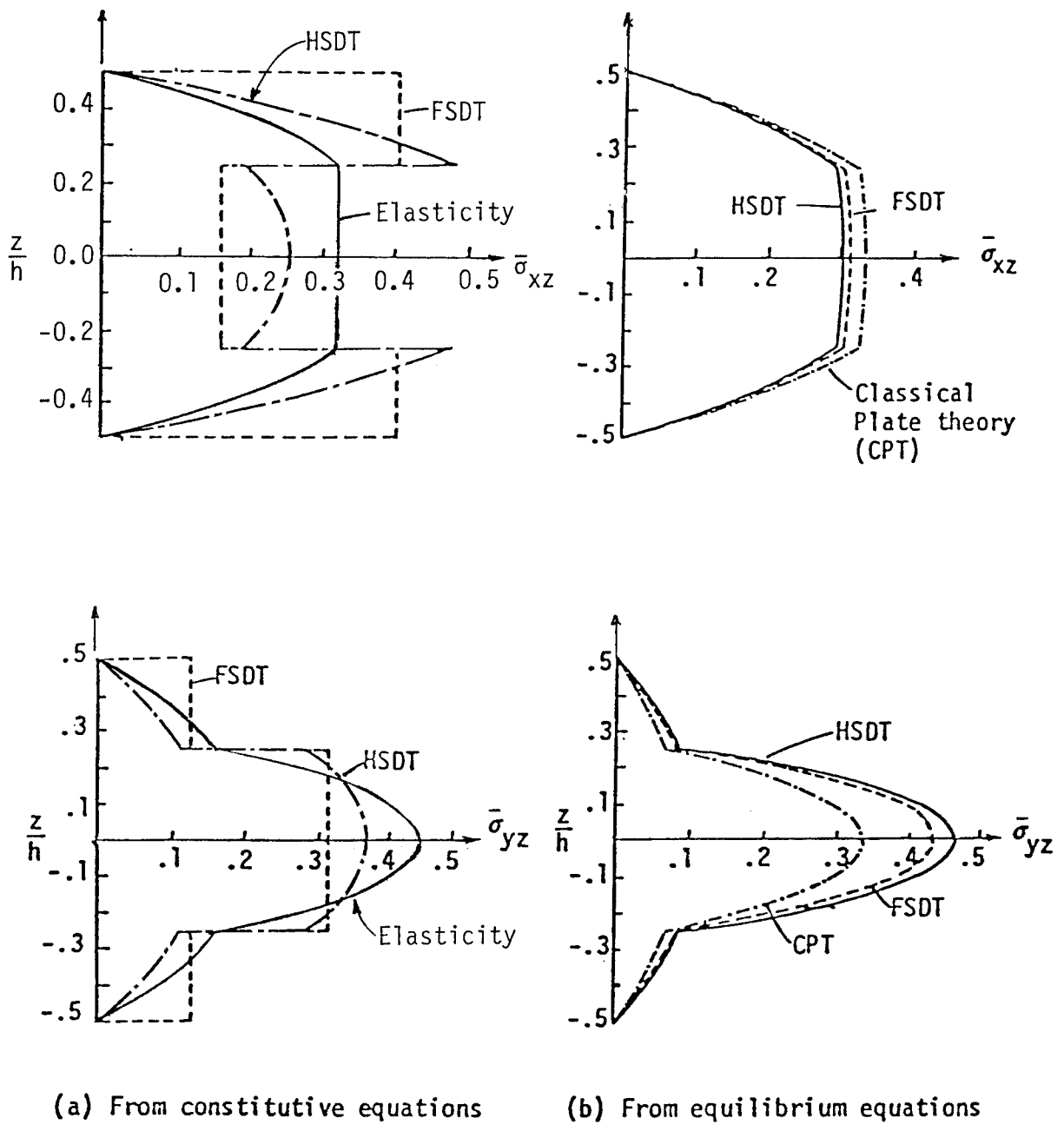

Figure 4. The distribution of normalized transverse shear stresses through the thickness of a four-layer [0/90/90/0] square laminated plate under sinusoidal load ($a/h = 10$).

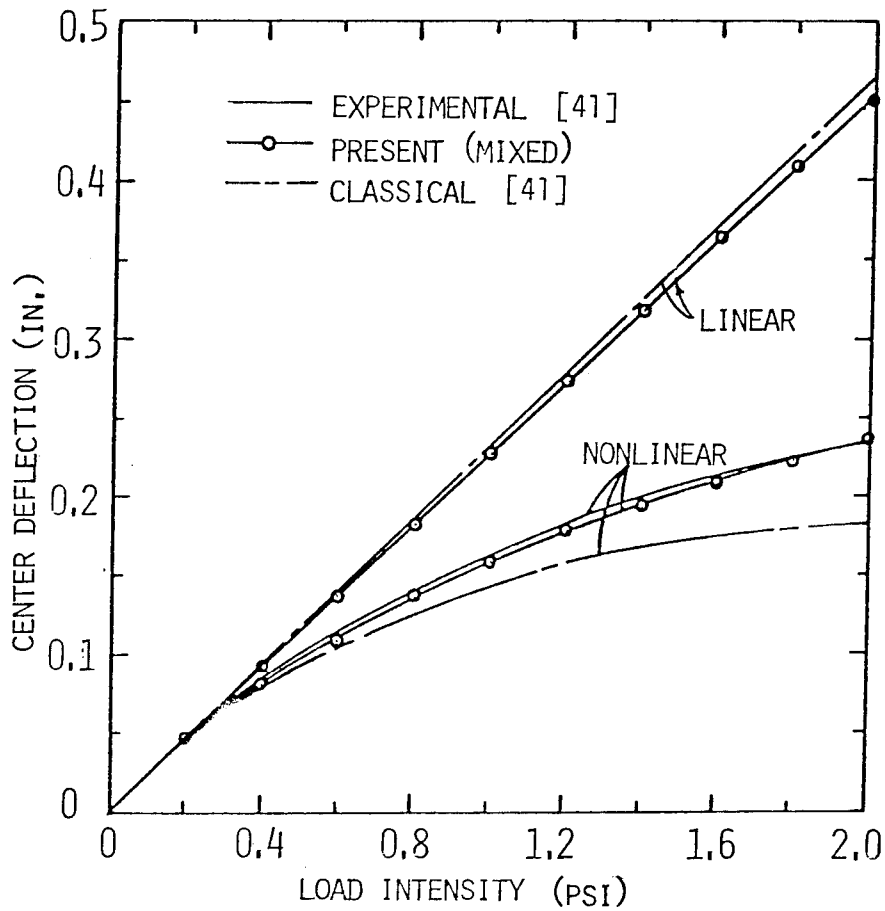

Figure 5. Center deflection versus load intensity for a simply supported square orthotropic plate under uniformly distributed transverse load. The following simply supported boundary conditions were used:

$$v = w = \psi_y = M_x = P_x = 0 \text{ on side } x = a$$

$$u = w = \psi_x = M_y = P_y = 0 \text{ on side } y = b$$

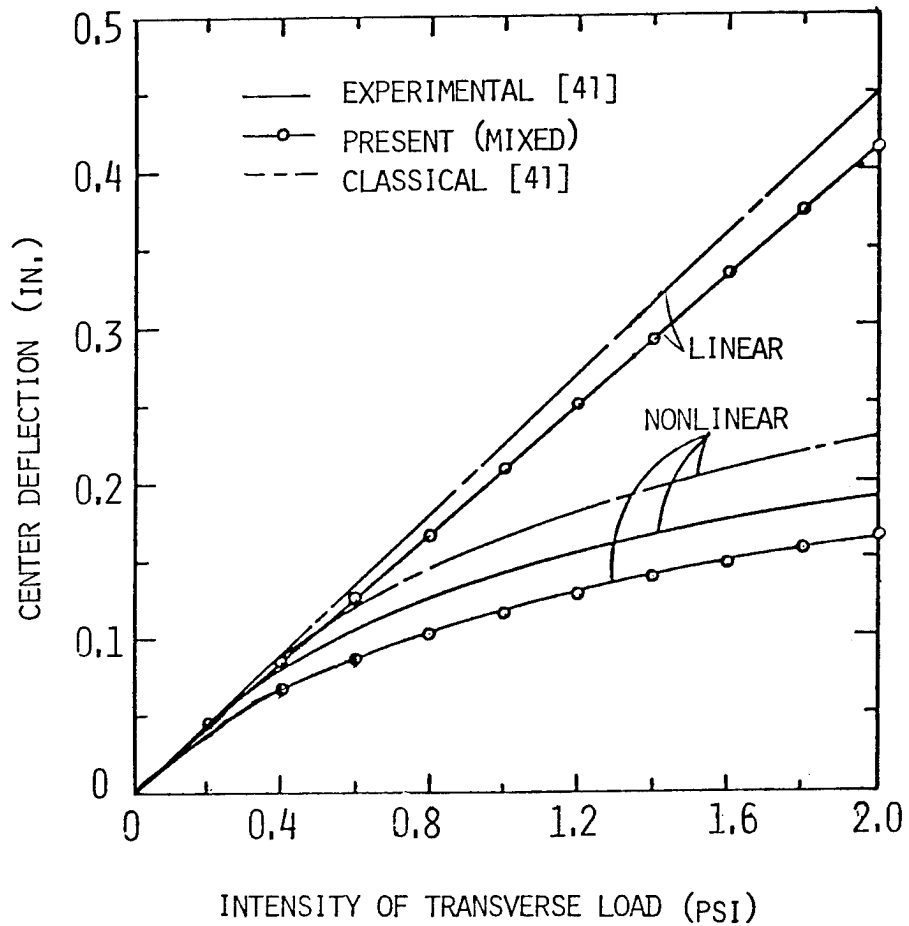

Figure 6. Center deflection versus load intensity for a clamped (CC-1) square laminate $[0/90/90/0]$ under uniform transverse load (von Karman theory).

$$\text{CC-1: } u = v = w = \psi_x = \psi_y = 0 \text{ on all four clamped edges}$$

1. Report No. NASA CR-3955	2. Government Accession No.	3. Recipient's Catalog No.	
4. Title and Subtitle A Refined Shear Deformation Theory for the Analysis of Laminated Plates		5. Report Date January 1986	
		6. Performing Organization Code	
7. Author(s) J. N. Reddy		8. Performing Organization Report No. VPI-E-85.26	
		10. Work Unit No.	
9. Performing Organization Name and Address Engineering Science and Mechanics Department Virginia Polytechnic Institute and State University Blacksburg, Virginia 24061		11. Contract or Grant No. NAG1-459	
		13. Type of Report and Period Covered Contractor Report	
12. Sponsoring Agency Name and Address National Aeronautics and Space Administration Washington, D.C. 20546		14. Sponsoring Agency Code 505-90-28-31	
		15. Supplementary Notes NASA Langley Technical Monitor: Dr. Norman Knight, Jr. First year report covering the research carried out during March 84 to March 85.	
16. Abstract A refined, third-order plate theory that accounts for the transverse shear strains is presented, the Navier solutions are derived for certain simply supported cross-ply and antisymmetric angle-ply laminates, and finite-element models are developed for general laminates. The new theory does not require the shear correction factors of the first-order theory (i.e., the Reissner-Mindlin plate theory) because the transverse shear stresses are represented parabolically in the present theory. A mixed finite-element model that uses independent approximations of the generalized displacements and generalized moments, and a displacement model that uses only the generalized displacements as degrees of freedom are developed. The displacement model requires C^1 -continuity of the transverse deflection across the inter-element boundaries, whereas the mixed model requires a C^0 -element. Also, the mixed model does not require continuous approximations (between elements) of the bending moments. Numerical results are presented to show the accuracy of the present theory in predicting the transverse stresses. Numerical results are also presented for the nonlinear bending of plates, and the results compare well with the experimental results available in the literature.			
17. Key Words (Suggested by Author(s)) Bending Closed-form solutions Finite-element analysis Laminated plates Shear deformation Third-order theory		18. Distribution Statement Unclassified - Unlimited Subject Category 39	
19. Security Classif.(of this report) Unclassified	20. Security Classif.(of this page) Unclassified	21. No. of Pages 36	22. Price A03