



**PORTABLE INSTRUMENT PACKAGE
(PORTAPAK) FOR THE MEASUREMENT
OF NOISE AND VIBRATION**

HARALD K. HILLE

J. F. ROSE, JR., MAJOR, USAF

Aerospace Medical Research Laboratory

L. KEITH KETTLER

University of Dayton Research Institute



19951120 073

MARCH 1970

This document has been approved for public release and sale;
its distribution is unlimited.

DTIC QUALITY INSPECTED 5

AEROSPACE MEDICAL RESEARCH LABORATORY
AEROSPACE MEDICAL DIVISION
AIR FORCE SYSTEMS COMMAND
WRIGHT-PATTERSON AIR FORCE BASE, OHIO

NOTICES

When US Government drawings, specifications, or other data are used for any purpose other than a definitely related Government procurement operation, the Government thereby incurs no responsibility nor any obligation whatsoever, and the fact that the Government may have formulated, furnished, or in any way supplied the said drawings, specifications, or other data, is not to be regarded by implication or otherwise, as in any manner licensing the holder or any other person or corporation, or conveying any rights or permission to manufacture, use, or sell any patented invention that may in any way be related thereto.

Federal Government agencies and their contractors registered with Defense Documentation Center (DDC) should direct requests for copies of this report to:

DDC
Cameron Station
Alexandria, Virginia 22314

Non-DDC users may purchase copies of this report from:

Chief, Storage and Dissemination Section
Clearinghouse for Federal Scientific & Technical Information (CFSTI)
Sills Building
5285 Port Royal Road
Springfield, Virginia 22151

Organizations and individuals receiving announcements or reports via the Aerospace Medical Research Laboratory automatic mailing lists should submit the addressograph plate stamp on the report envelope or refer to the code number when corresponding about change of address or cancellation.

Do not return this copy. Retain or destroy.

14. KEY WORDS	LINK A		LINK B		LINK C	
	ROLE	WT	ROLE	WT	ROLE	WT
Instrumentation Noise Vibration Measurements						

Foreword

The portable instrument package (PORTAPAK) was designed and fabricated by the Biodynamic Environment Branch, Biodynamics and Bionics Division, Aerospace Medical Research Laboratory, Wright-Patterson AFB, Ohio. The work was performed by Mr H. K. Hille and Major J. F. Rose, Jr., Biodynamic Environment Branch, with a major contribution by Mr. L. K. Kettler, University of Dayton Research Institute, under Project 7231, "Biomechanics of Aerospace Operations" and Task 723104, "Biodynamic Environment of Aerospace Flight Operations," Work Unit No. 028. Acknowledgment is made of the assistance by the Fabrication and Modification Division, Aeronautical Systems Division, for fabricating the case for the package.

This technical report has been reviewed and is approved.

C. H. KRATOCHVIL, Colonel, USAF, MC
Commander
Aerospace Medical Research Laboratory

Accession For	
RTIS GRAAI	<input checked="" type="checkbox"/>
DTIC TAB	<input type="checkbox"/>
Unannounced	<input type="checkbox"/>
Justification	
By _____	
Distribution/	
Availability Codes	
Dist	Avail and/or Special
A-1	

Table of Contents

<i>Section</i>	<i>Page No.</i>
I. INTRODUCTION	1
II. DESCRIPTION OF SYSTEM	2
PHYSICAL CHARACTERISTICS	2
ELECTRICAL CHARACTERISTICS	4
III. DESCRIPTION OF COMPONENTS	10
TAPE RECORDER	10
MICROPHONE WITH COMPLEMENT	12
VIBRATION TRANSDUCER	12
AUXILIARY EQUIPMENT	13
APPENDIX I. SPECIFICATIONS OF EQUIPMENT	15

List of Illustrations

	<i>Page No.</i>
No. 1. The Portable Instrument Package (PORTAPAK)	2
No. 2. Sideview of the Connector Panel	3
No. 3. Simplified Block Diagram of the Recording System	4
No. 4. Detailed Circuit Diagram of the Recording System	5
No. 5. Frequency Response and Dynamic Range of the Acoustical Recording Section	7
No. 6A. Characteristics of the Vibration Recording Section – Frequency Response	8
No. 6B. Characteristics of the Vibration Recording Section – Dynamic Range for 3 Different Acceleration Levels	8
No. 6C. Characteristics of the Vibration Recording Section – Noise Floor Recorded Under Different Conditions	9
No. 7. Frequency Response of Tape Recorder for 3 Speeds with Different Equalizations	10
No. 8. Noise Floor of Tape Recorder	11
No. 9. Transducers and Auxiliary Equipment for the PORTAPAK	13

Section I

INTRODUCTION

With the continuing development of new aircraft, helicopters, and larger propulsion systems, considerable effort has been made to document the noise and vibration environments generated during inflight and ground operations. This documentation is needed to provide the necessary information to evaluate the effects of such environments on structures and personnel and to establish requirements for ear protection and communication systems. Accurate description of the noise sources provides further information for proper noise control, and the data can be used by air base planners, to evaluate community response to aircraft operations. Documentation of vibration environments present in these aerospace systems are of interest for biomechanical evaluations in the frequency range from dc to 30 Hz. Data acquired are used for simulation studies in the laboratory to establish vibration tolerance criteria for crewmembers.

The PORTAPAK is a single channel recording system for the recording of either acoustic or vibration environments. This portable system was designed for use in aircraft or in the field under conditions that restrict the use of larger and heavier recording equipment. The PORTAPAK is a light-weight, self-contained recording system consisting of a tape recorder and associated circuitry, a condenser microphone as an acoustical transducer, and a linear servoaccelerometer as the vibrational transducer. A complete description of the system and its performance characteristics for both acoustical and vibrational recording capability are given. Wow and flutter measurements including sensitivity of the complete system when exposed to a noise field in excess of a 150 dB sound pressure level are presented and characteristics of the PORTAPAK are compared with laboratory recording systems. In addition, specifications of the equipment and components incorporated into the system are listed in Appendix I.

Section II

DESCRIPTION OF SYSTEM

PHYSICAL CHARACTERISTICS

Measurement of noise and vibration environments in the field around aircraft and other noise generating systems and during inflight operations often requires elaborate recording systems, consisting of a tape recorder, a condenser microphone as the transducer, and other associated equipment. In many cases, however, the physical size of the conventional equipment with its power requirements prohibits data acquisition on board an aircraft or at remote ground stations. Especially with the development of new aircraft such as the F-4C and F-111, space limitations for the installation of such tape recorder and associated equipment restrict data acquisition during in-flight operations.

These restrictions and space limitations led to the development of a special recording system with physical and electrical design considerations that eliminate previous deficiencies.

The physical layout and characteristics of the PORTAPAK are such that it can be used for most any single-channel survey on the ground or in any aircraft. Under these conditions, ease of operation is maintained, the controls and meters are easily accessible, and the auxiliary equipment including the transducers is stored in the same case. Fig. 1 shows the recording system with the transducers and its calibrator in place.

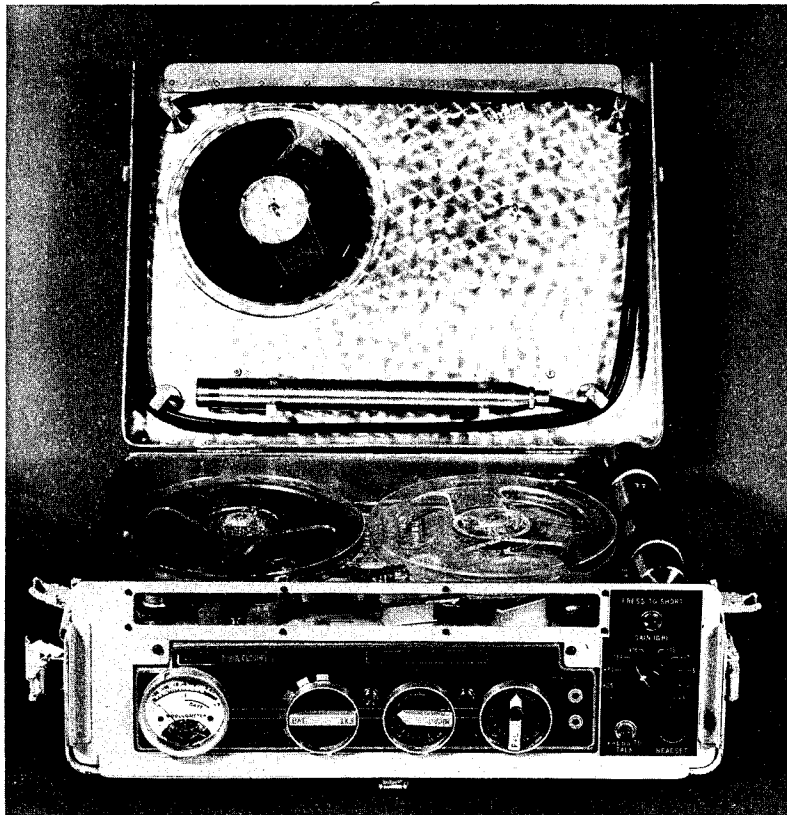

Fig. 1. The Portable Instrument Package (PORTAPAK)

The portable system weighs only 30 pounds and the overall dimensions are 17 inches wide, by 14½ inches deep, by 5½ inches high. It can be handcarried on-board an aircraft and operated without using aircraft power. In a field survey when conventional measurement methods are applied (250 ft walk around) the system can be carried by means of a shoulder strap.

The operating controls including the VU Meter are located at the front of the system with the exception of the tape transport control knob, which is accessible from the top of the tape recorder. These controls are protected during transportation by a removable cover attached by latching devices to the main case and incorporates a handle for convenient transport. Tape threading is accomplished in the conventional manner at the top where tape reels and head assembly are located. The tape transport and head assembly is also protected by a hinged lid in which two extra tape reels and the condenser microphone with its cable are stored when the system is not in use. The top cover plate contains the acoustical calibrator which is used to apply an acoustical signal for calibration of the system in the field. During operation the tape motion can be observed with the top cover closed through a window at the front panel.

At the right side of the case, the connectors for the transducers, aircraft communication system and data output are located as shown in fig. 2. These connectors are recessed in such a way as to prevent damage during transportation.

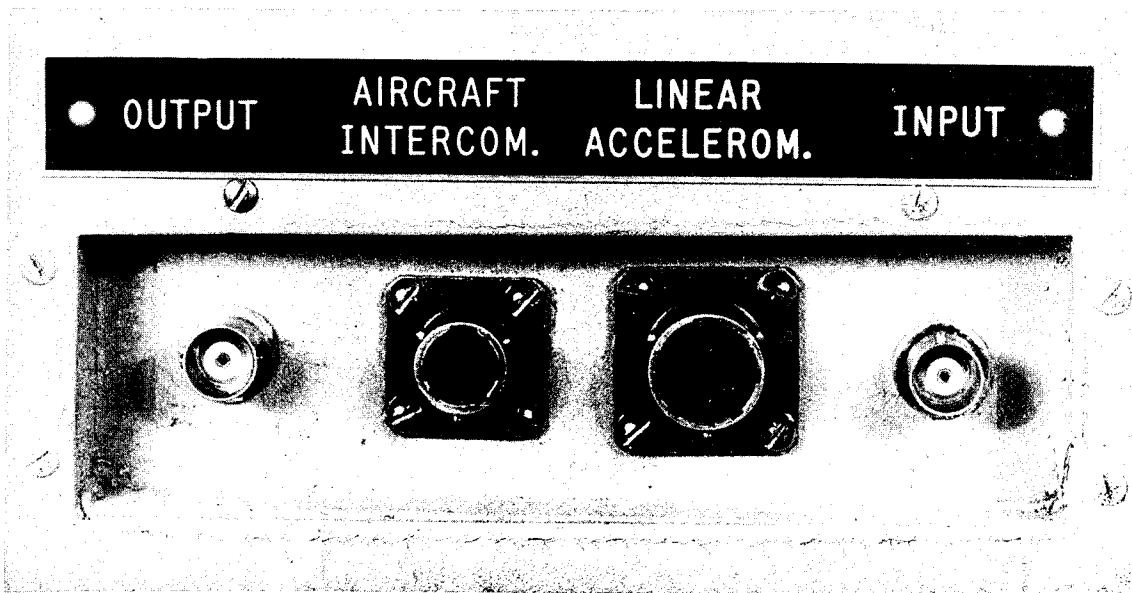

Fig. 2. Side View of the Connector Panel

The case was designed and fabricated to provide a protective housing for the equipment exposed to the environments associated with aircraft operations. The tape recorder is shock mounted

by foam rubber glued to the inside and in addition rubber feet are mounted at two sides of the case to prevent severe shocks during transportation and handling of the system.

ELECTRICAL CHARACTERISTICS

A recording system for noise and vibration environments must meet certain electrical requirements to obtain the most faithful recording and reproduction of a complex signal. A frequency response from 20 to 20 kHz ± 2 dB, low distortion (less than 1%), and a high signal to noise ratio of the microphone, tape recorder and its associated signal conditioning circuitry are significant factors in the design of such a system. Gain and attenuation for the signal to be recorded must be provided to increase the dynamic range of the recording system and the recording time must be sufficient for continuous recording of data samples with larger durations. In addition, the speed stability of the tape recorder to be used in a system must be compatible with laboratory instrumentation recorders to facilitate an accurate reproduction of the recorded data in the laboratory.

In designing the PORTAPAK equipment, components were selected that meet the requirements for an overall system performance as stated above. Its simplified functional block diagram is shown in fig. 3. The output from the condenser microphone and its battery operated cathode follower is applied to the input connector for the acoustical transducer. The microphone system is properly impedance matched through an operational amplifier, and the signal applied to the tape recorder can be amplified or attenuated in increments of 5 dB, from -15 dB to +30 dB. The signal from the vibration transducer, a linear servo accelerometer, is attenuated by an operational

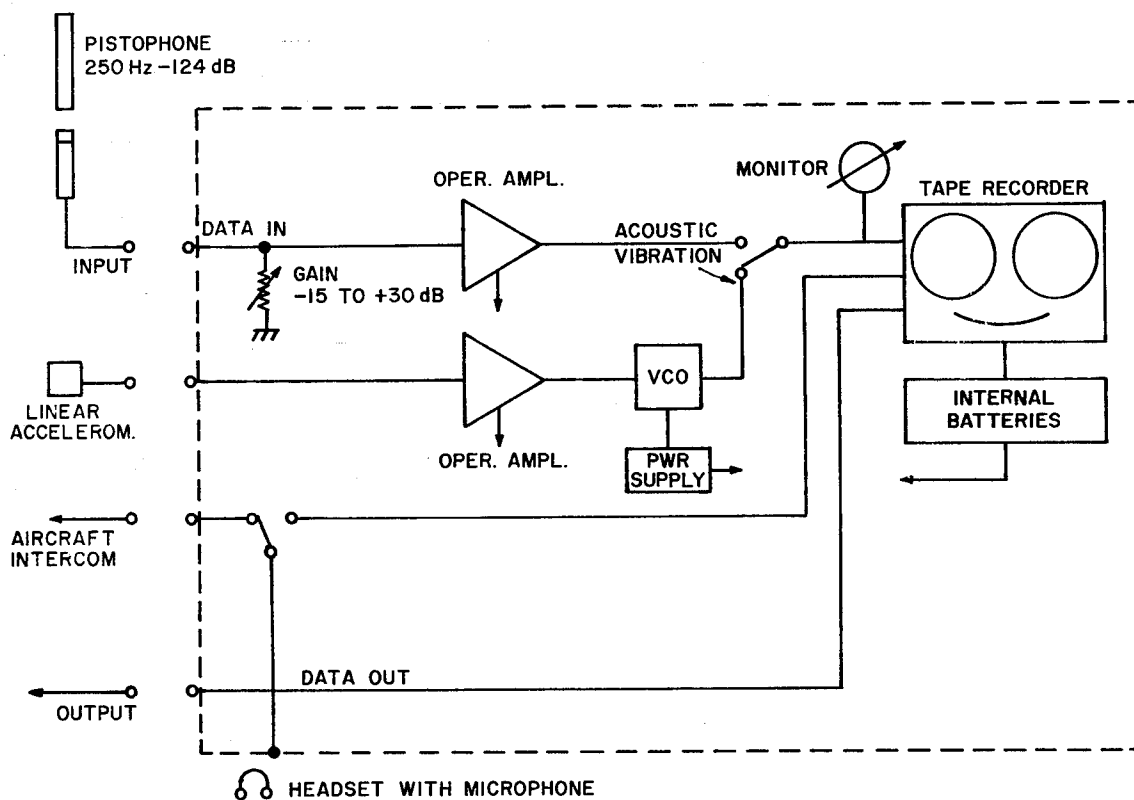

Fig. 3. Simplified Block Diagram of the Recording System

amplifier which drives a voltage controlled oscillator. This FM signal is recorded, and it contains the signal from the vibration transducer in the frequency range from 0 to 30 Hz. Voice annotation can be recorded by connecting a headset (H-157) or helmet to the front jack of the PORTAPAK. During inflight recordings, the PORTAPAK can be connected with the aircraft intercom system. In this case the pilot and the operator can communicate with each other and the operator can also record flight conditions.

Power for the PORTAPAK is provided by batteries contained in a case located under the top plate for the signal conditioning circuitry. The batteries for the tape recorder are located at the bottom of the housing accessible through a removable cover. The power required for the signal circuitry, an operational amplifier and a voltage controlled oscillator, is ± 15 and $+28$ vdc respectively. It is provided by six $7\frac{1}{2}$ vdc "A" batteries. The necessary power for the tape recorder of $+18$ vdc is obtained from twelve $1\frac{1}{2}$ vdc "D" size batteries.

The detailed circuit diagram is presented in fig. 4. The circuitry of the tape recorder is not included in this diagram since the tape recorder is a commercially available item.

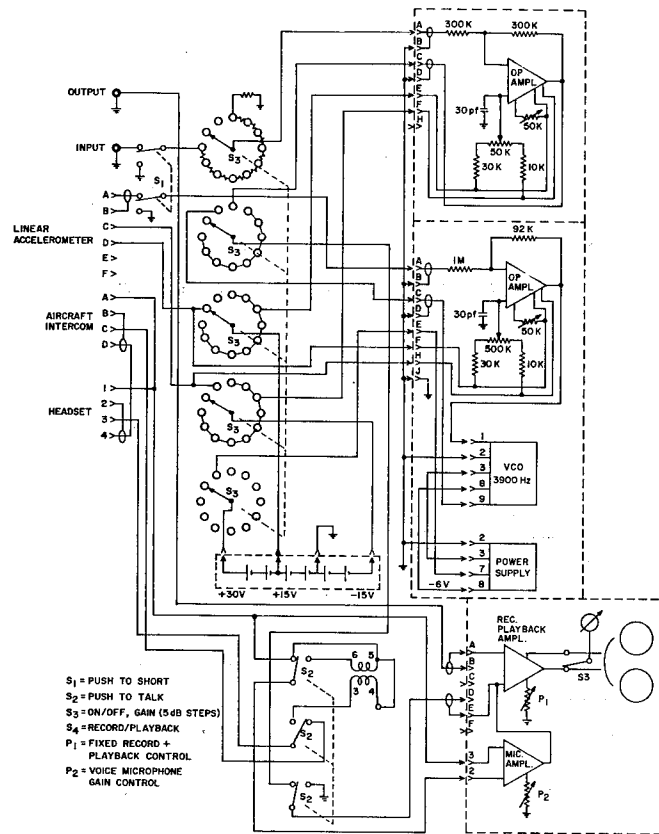

Fig. 4. Detailed Circuit Diagram of the Recording System

In general the recording system is divided into two sections: the acoustical section and the vibration signal conditioning circuitry section. The mode for the recording of acoustical or vibration data can be selected with the main function switch (S3) located at the right hand side of the PORTAPAK. Operation of this switch also applies power to the individual signal conditioning circuitry. The tape recorder, however, is energized by a separate function switch in the test posi-

tion which enables the operator to monitor the signal. After the PORTAPAK is energized and the desired recording mode is selected the signal from the acoustical transducer and its cathode follower is applied to the shorting switch (S1) that appears on the front panel as a push button (Press to Short). This feature enables the operator to record a shorted input before recording a data sample to establish the noise floor and subsequently the dynamic range of the system. In the normal position this push button connects the incoming signal to the function switch (S3), which is also used in the acoustical recording mode as a step attenuator. In connection with an operational amplifier the signal from the acoustical transducer can be amplified or attenuated in increments of 5 dB, from -15 dB to +30 dB. In the 0 dB position the input signal is so controlled that an input signal of 1V will not overload the tape recorder. The signal level can be monitored by a VU meter mounted at the front of the tape recorder. In addition to the step attenuator (S3) the tape recorder has a separate gain control fixed by means of a set screw in a preset position and therefore, the signal from the acoustical transducer is only controlled by the step attenuator (S3). To record voice transmissions the data input can be disconnected from the tape recorder by the switch S2 (Press to Talk). Its operation connects the voice microphone from the H-157 headset to the recorder and allows the operator to record pertinent comments at the beginning or during the recording of data. The data input is disconnected when the switch S2 is depressed.

The recorded data may be played back through a loudspeaker located within the tape recorder. The playback mode is selected by placing the main function switch (S3) in the "off" position at the tape recorder. In fig. 5 the overall system response for the acoustical section is shown. Discrete frequencies were applied to the input of the cathode follower and then recorded. The data are presented with the corrections for microphone, cathode follower, and tape recorder responses applied.

With the proper selection of microphones, sound pressure levels in a range from 54 to 135 dB can be recorded. This upper range can be extended by 15 dB since the cathode follower accepts voltage levels up to 8v (+18 dB re 1v) and the microphone diaphragms will not be damaged when exposed to these higher levels. The lower curve in fig. 5 shows the noise floor of the system recorded in an anechoic chamber with the microphone attached to the PORTAPAK. It represents the actual noise of the recording system analyzed in $\frac{1}{3}$ -octave bands as a function of sound pressure levels in dB re 0.0002 dyne/cm². The noise floor of the anechoic chamber was measured and analyzed and found to be 5 to 10 dB lower in these bands. Therefore, the data presented in the lower curve is the actual noise-floor of the system.

For the measurement of the vibration environments a linear servo accelerometer, as the transducer, is used that covers the frequency range of interest (0 to 30 Hz) for the vibration measurements. However, for the recording of the vibration data a different circuitry is employed. The low frequency response of the tape recorder is not sufficient to properly record the frequency range of 0 to 30 Hz. Therefore, a voltage controlled oscillator is used that provides a frequency modulated signal output which corresponds to the data signal introduced at the input.

The output from the vibration transducer is applied to the switch S1 (Press to Short) and to the main function switch (S3) for selection of the vibration recording mode by the operator. After the mode is selected the signal is introduced to an operational amplifier which attenuates the signal sufficiently to drive the voltage controlled oscillator at a center frequency of 3,900 Hz with a deviation of $\pm 7.5\%$. The selection of this sub-carrier band was made because the intelligence frequency in this band is 60 Hz within the range of interest. The signal output from the voltage controlled oscillator is attenuated to a level that does not overload the tape recorder if the maximum possible signal from the transducer is applied. Fig. 6A shows the frequency response of the vibra-

tion signal conditioning circuitry played back through a discriminator. The input signal to this circuit was simulated by an oscillator. The frequency response in the range from 0 to 30 Hz is essentially flat. The transducer was dynamically calibrated and it was found to be flat within ± 0.2 dB in the frequency range of interest.

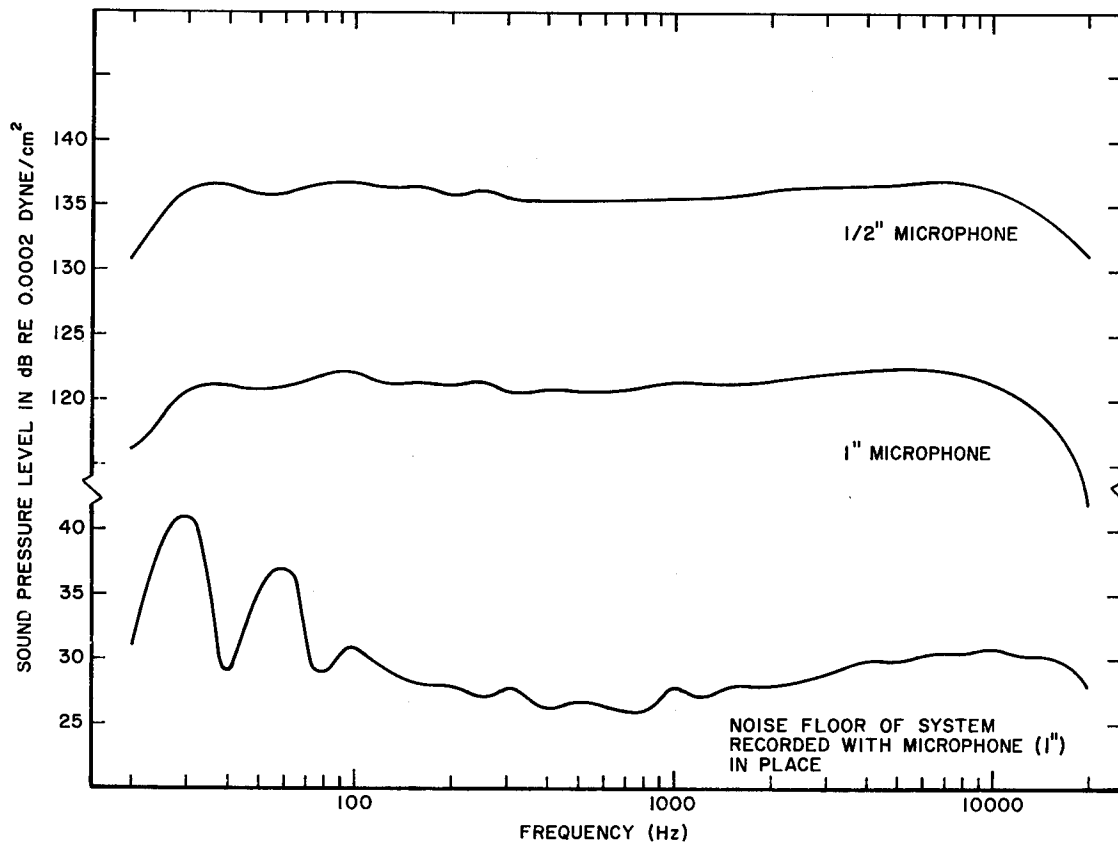

Fig. 5. Frequency Response and Dynamic Range of the Acoustical Recording Section

As stated, the gain for the vibration recording section is fixed, however, the recording of different acceleration levels is possible by selecting the appropriate range of the transducer. In fig. 6B the dynamic range of three different linear servo accelerometers is shown. The maximum ranges of these transducers for acceleration measurement are ± 1 g., ± 2 g and ± 5 g. The voltage output is ± 7.5 vdc for full range excitation. For displaying the dynamic range of such a transducer, an appropriate signal representative of the different acceleration ranges was recorded and reproduced through a discriminator and displayed on a graphic level recorder. The dynamic range of such recording is 35 dB, whereby the lowest voltage to be recorded is approximately 8 dB above the noise floor.

Fig. 6C represents the spectral content of the noise level of the vibration record/reproduce electronics recorded under different conditions and as reproduced through the 3.9 kHz discriminator. The output signal was analyzed with a $\frac{1}{3}$ -octave band analyzer. Curve A shows the noise

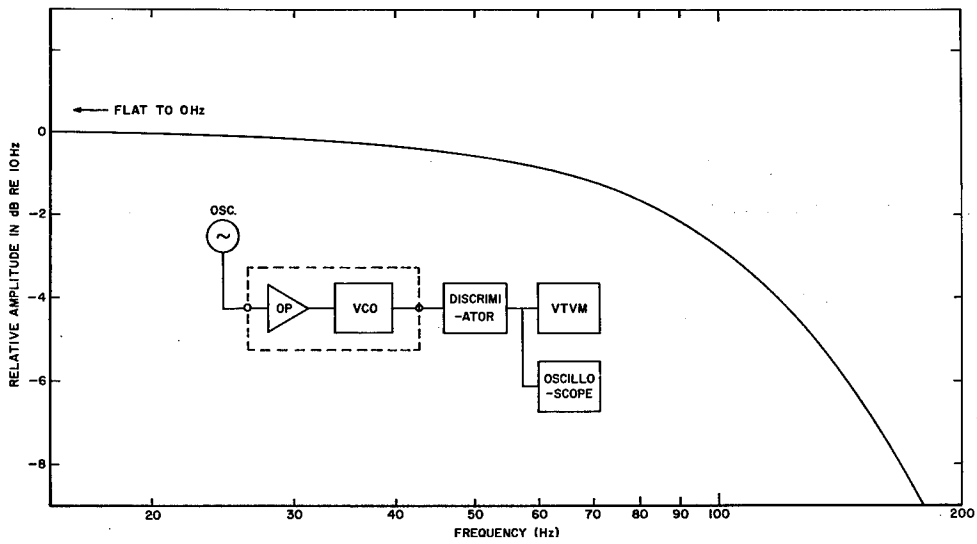

Fig. 6A. Characteristics of the Vibration Recording Section — Frequency Response

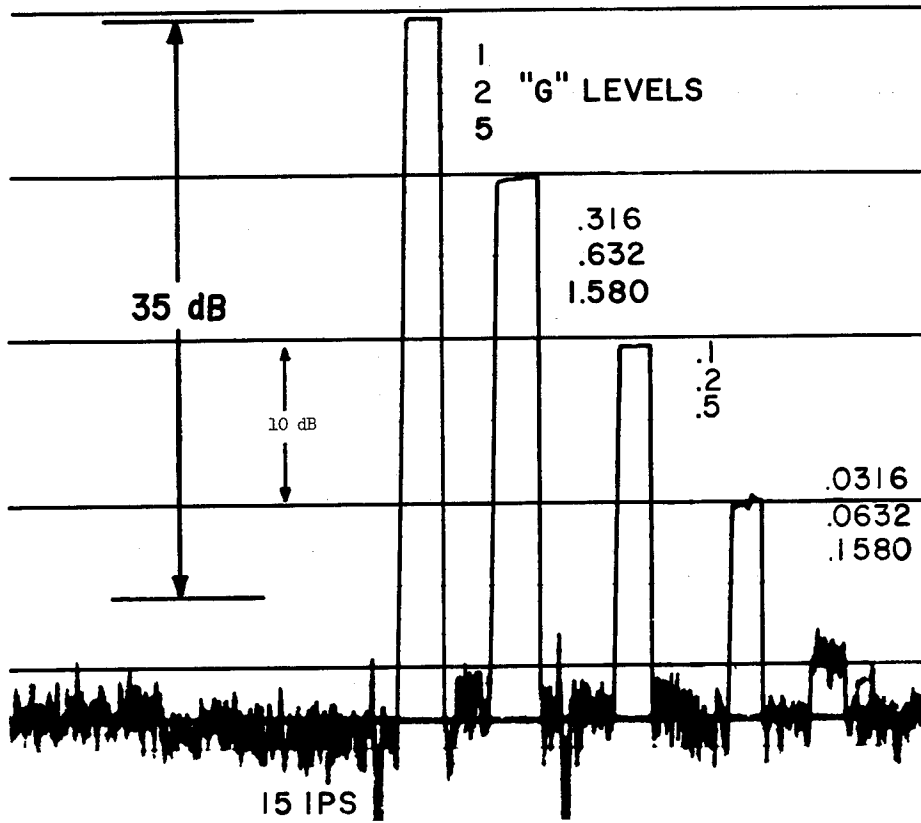

Fig. 6B. Characteristics of the Vibration Recording Section — Dynamic Ranges for 3 Different Acceleration Levels

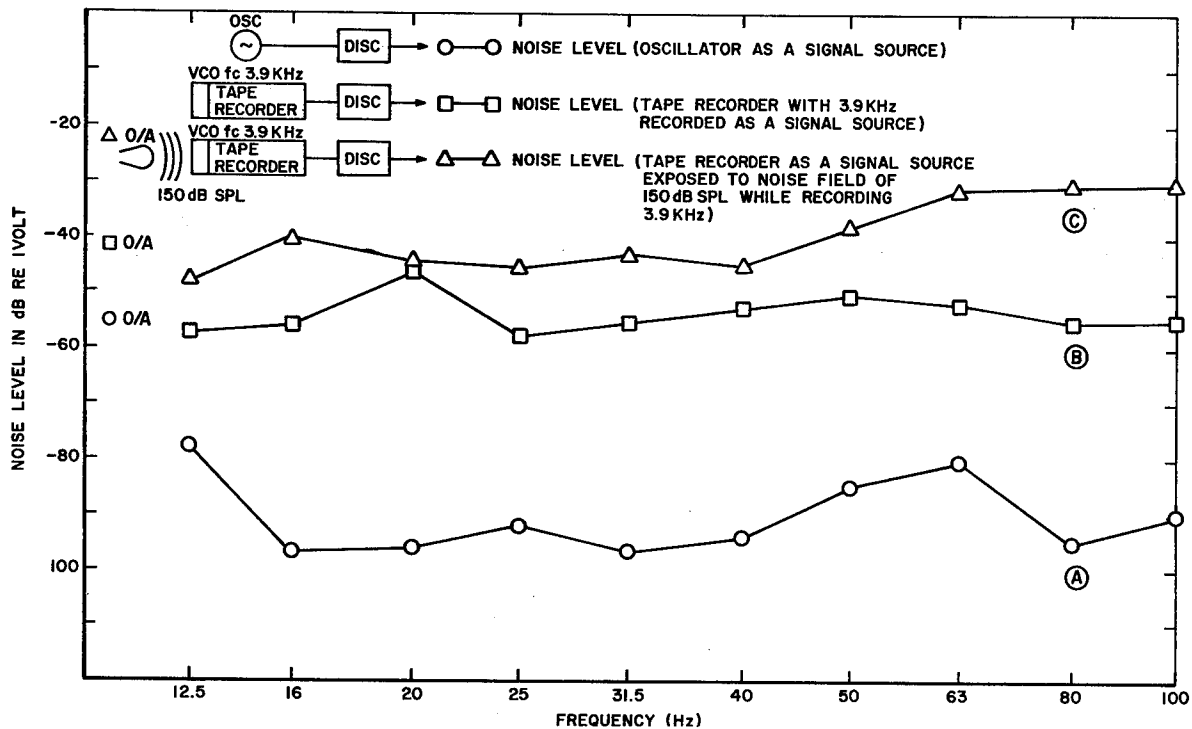

Fig. 6C. Characteristics of the Vibration Recording Section — Noise Floor Recorded Under Different Conditions

level of the discriminator itself using an oscillator as the signal source, the normal condition. In curve B the tape recorder was used as a signal source by recording a 3.9 kHz signal which then was reproduced through the discriminator. The increase in the noise level is due to the wow and flutter of the tape recorder. In the third condition the effects of high intensity noise on the recording system can be seen (Curve C). The PORTAPAK with its tape recorder was exposed to high intensity broadband noise of 150 dB SPL, while recording a 3.9 kHz signal. The exposure of the tape recorder to such high intensity noise causes an increase in the wow and flutter and subsequently the overall noise level. However, in most cases the PORTAPAK can be protected from such exposure by extending the transducer cable and operating the recording system under a protective cover.

Section III

DESCRIPTION OF COMPONENTS

TAPE RECORDER

The tape recorder incorporated into the PORTAPAK consists basically of a tape transport, a head assembly for full track (single channel) operation for use with 1/4-inch magnetic tape and an electronic assembly that contains the record and reproduce amplifier, bias and erase oscillator.

On the front panel are controls for setting the record level for the line input (data) and playback level. In addition, a second input (microphone) is provided that can be controlled with a separate level control. This input provides a higher input sensitivity for use with a low impedance dynamic microphone. By means of a function switch the record or playback mode can be selected and monitored at the VU meter also located on the front panel. A test position is provided for monitoring the input level to be recorded without energizing the tape transport. The tape recorder can also be used with an external power source in which case the external mode of the function switch is selected.

An important feature independent of the requirement for faithful recording and reproduction of a signal (good frequency response, low distortion, and high signal to noise ratio) is speed stability to maintain compatibility with laboratory instrumentation recorders. A servo circuit is employed in this recorder to control and maintain a constant speed over a supply voltage range from 12 to 18 vdc.

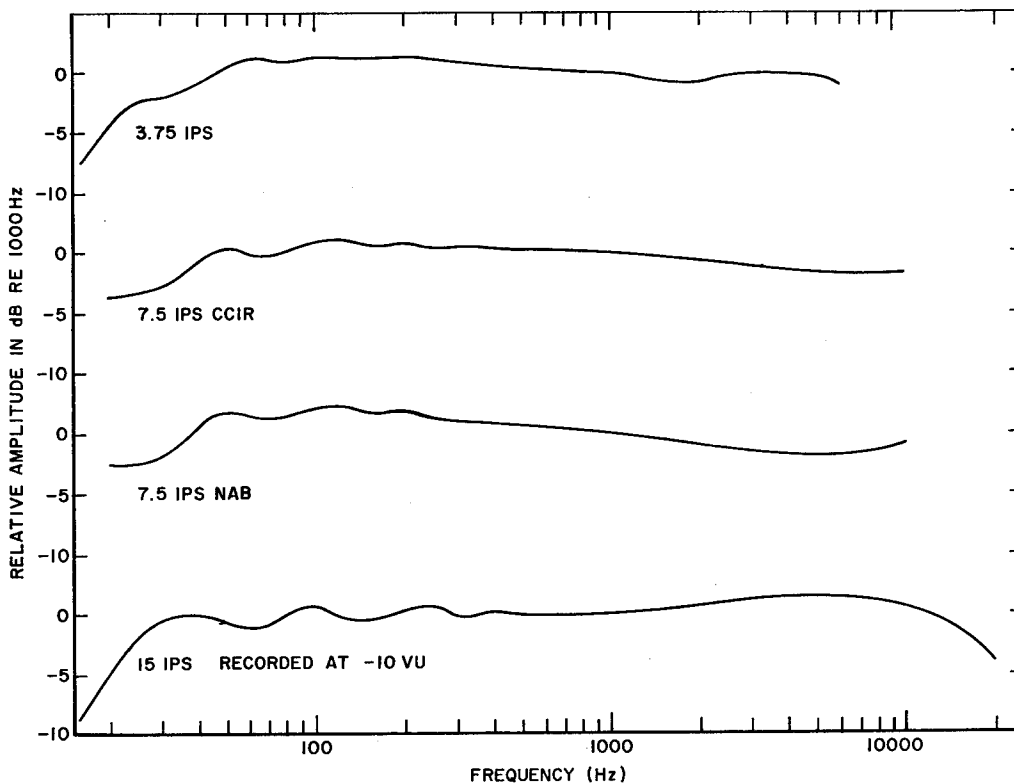

Fig. 7. Frequency Response of Tape Recorder for 3 Speeds With Different Equalizations

The tape transport operates at speeds of 3¾, 7½, and 15 ips with equalization both for record and playback conforming with the CCIR and Ampex Equalization Standard. Fig. 7 presents the frequency response for these speeds as a function of relative amplitude in dB re 1000 Hz. For the tape speed of 7½ ips the low frequency characteristics with the two different equalization standards are shown. The best response curve is obtained at 15 ips. At this speed the response is affected very little when the recorder is used with different types of magnetic tape and in addition the tape speed is compatible with the laboratory instrumentation recorder. The recordings were made at room conditions with new batteries and an input signal of -10 VU.

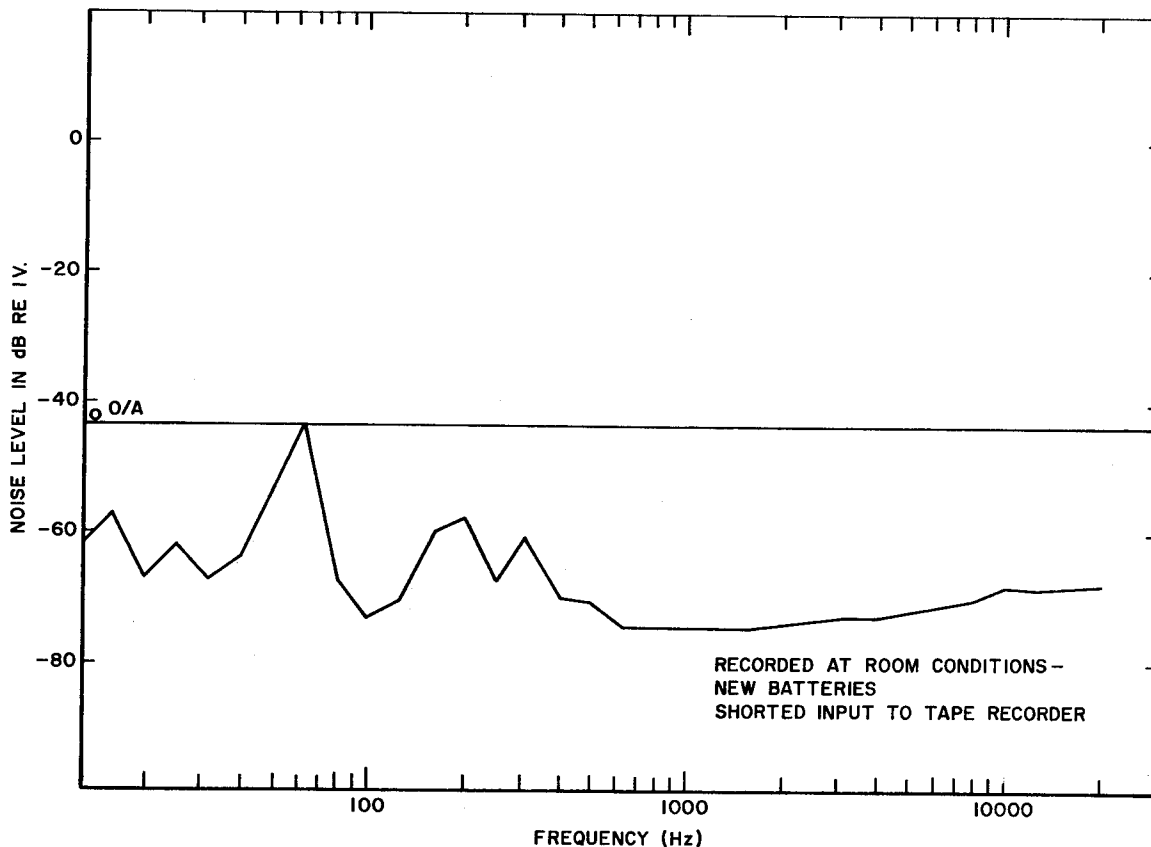

Fig. 8. Noise Floor of Tape Recorder

In fig. 8 the noise level of the tape recorder in one-third octave bands is presented. This recording was made with a shorted input and the overall noise level is -42 dB. In the one-third octave band analysis a 60 Hz signal predominates. This signal is attributed to the square wave generator used for the speed control of the tape transport as described earlier. The tape recorder is battery operated and further specifications are given in Appendix I.

MICROPHONE WITH COMPLEMENT

For precise sound pressure measurement a condenser microphone has many advantages not found with other conventional microphones. The most outstanding feature is its long term stability under a great range of environmental conditions, due primarily to its insensitivity to temperature variations. In addition, the frequency characteristics of the condenser microphone cover the whole audio frequency range from 20 Hz to 20 kHz. Condenser microphones have different sensitivities and can be selected for each individual measurement range of the system. It is well suited for field measurements and easy to calibrate with standard conventional acoustical calibrators or it can be readily calibrated against laboratory standards.

For these reasons the condenser microphone was selected for the acoustical transducer in the PORTAPAK. The only disadvantage of this microphone is the necessity of a polarized d-c voltage which has to be provided to the two electrodes (back plate and diaphragm).

The complete microphone complement consists of the microphone cartridge and a battery operated cathode follower for impedance conversion to transform the high source impedance of the transducer to a low output impedance to allow the use of a long cable and a low input impedance amplifier between the microphone and recording system.

Two different microphones are available for the PORTAPAK. The 1 inch microphone cartridge has a sensitivity of approximately -45 dB re $1\text{v}/\mu\text{bar}$. The $\frac{1}{2}$ inch microphone cartridge has a sensitivity of approximately -60 dB re $1\text{v}/\mu\text{bar}$. Sound pressure levels up to 150 dB can be measured with the 1 inch microphone and up to 160 dB with the $\frac{1}{2}$ inch microphone without damaging the diaphragm. The 1 inch microphone is fastened directly to the housing of the cathode follower. When measurements are made with the $\frac{1}{2}$ inch microphone, the cartridge is placed onto the cathode follower by means of an adapter. This adapter is 130 mm long and so extends the low capacity guard ring arrangement between the microphone cartridge output and the cathode follower input that the change in sensitivity is negligible (-0.2 dB). For the measurement of even higher sound pressure levels a $\frac{3}{4}$ inch microphone cartridge is available. However, precautions have to be exercised in calibrating this arrangement since another adapter is used which is attached onto the $\frac{1}{2}$ inch adapter.

The cathode follower used is a battery operated unit in which 3 small mercury cells deliver the necessary polarized d-c voltage for the microphone cartridge, plate, and filament voltages for the vacuum tube. A small voltmeter is also included for checking the battery voltage. It has a useable frequency range of 20 Hz to 20 kHz and with an 8 v input voltage the harmonic distortion is less than 2%. Fig. 9 shows the two microphones and the battery operated cathode follower. A conventional wind screen is also shown that fits all microphones and is used to reduce the effect of wind noise.

VIBRATION TRANSDUCER

For the vibration measurements, a linear servo accelerometer that measures acceleration up to 5G in the frequency range from 0 to 30 Hz with sufficient sensitivity, accuracy, and resolution was selected as the transducer. This type of transducer is a radical departure from conventional accelerometer design. It functions as a miniature servo system that is responsive to input accelerations along its sensitive axis and which has an analog voltage output that is directly proportional to the input acceleration. The servo nulling amplifier, which is an operational amplifier, is located in the transducer housing and requires a supply voltage. A voltage of ± 15 vdc is supplied by the PORTAPAK through a cable and connector to the transducer. The output impedance is 5,000 ohms so that a longer cable can be used without deterioration of frequency response and resolution, and no additional amplification of the signal is necessary.

The linear servo accelerometer was statically and dynamically calibrated in the frequency range from 2 Hz to 30Hz at different acceleration levels. The calibration showed that the response of the transducer is flat within ± 0.2 dB in this frequency range and that the natural frequency (200 Hz) is outside the range of interest.

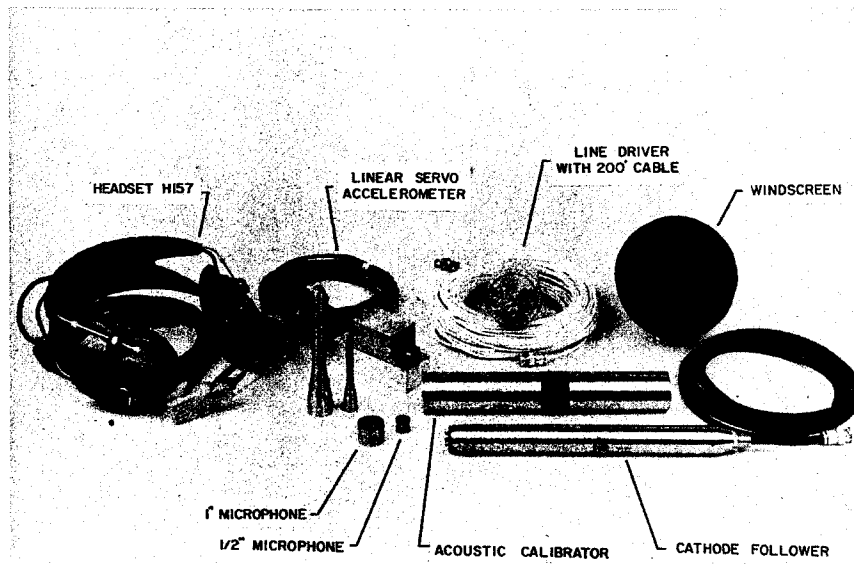

Fig. 9. Transducers and Auxiliary Equipment for the PORTAPAK

Field calibration of this transducer can be conveniently accomplished by rotating the position of the accelerometer in the vertical (gravity) plane, or by the current torque method, which is a unique feature of this type accelerometer. In this case an external current is applied through the torque coil. The response of the entire servo system of the accelerometer will be the same since the electro-mechanical servo cannot differentiate between the electrical (simulated acceleration) input and a true inertial input.

The transducer, as shown in fig. 9, is designed for ease of installation on board an aircraft or helicopter. Accelerometers having different ranges (1G, 2G and 5G) are available and can be used with the PORTAPAK as required. The physical and environmental parameters of this particular transducer is listed in the appendix I.

AUXILIARY EQUIPMENT

The PORTAPAK was designed primarily for the acquisition of noise and vibration environmental data in and around aircraft and other Air Force Systems. In using such an instrument package in remote locations it must be self-contained and necessary support equipment must be on hand for the calibration and checkout before each test. Fig. 9 shows a photograph of the auxiliary equipment that is essential for the proper recording of data during a field survey. The headset with its microphone is used for voice transmissions and can be substituted during flight operations by a helmet. The two microphone adapters are used with a $\frac{1}{2}$ and a $\frac{1}{4}$ inch microphone for the recording of sound pressure levels which exceed the dynamic range of the 1 inch microphone.

The acoustical calibrator is a mechanical pistonphone where two pistons are symmetrically driven by means of a miniature electric motor. It is battery operated and provides an absolute calibration of the whole recording system. With additional couplers it can also be used for the $\frac{1}{2}$ and $\frac{1}{4}$ inch microphones. The sound pressure level generated by the pistonphone is 124 dB with a maximum error of ± 0.2 dB. The cathode follower that contains the microphone cartridge is also shown. It is battery operated and used for impedance conversion allowing longer cables and relatively low input impedance amplifiers to be used between the microphone and the recording instruments. In addition a wind screen that fits all microphone sizes is part of the auxiliary equipment and is used for recordings during adverse weather conditions such as rain and wind.

A line driver with 250 ft of coaxial cable is employed when the PORTAPAK is located remotely from the noise source to be measured. The line driver is a self-contained operational amplifier which so drives the cable that the frequency characteristics and the noise floor of the system are unchanged.

The transducer for vibration measurements is a linear servo accelerometer and is shown mounted on its fixture with the cable for connection to the PORTAPAK.

In addition to the accessories, which are stored in the housing for the PORTAPAK, another case is available containing a battery operated oscilloscope and signal generator. The oscilloscope is used for visual monitoring of recorded data in the field, and the oscillator is used to record discrete frequencies before the test, which are required to identify the response of the system during the later analysis of the data. Additional equipment such as a volt-ohm meter, cable, etc., are also stored in this case to aid in the performance of minor repairs and adjustments during field operations if the system is malfunctioning.

Appendix I

SPECIFICATIONS OF EQUIPMENT

TAPE RECORDER, KUDELSKI TYPE NAGRA III

SPECIFICATIONS

1. Frequency Response:

At 15"/sec — 30 c/s to 18.000 c/s \pm 1 dB (30 c/s to 16.000 c/s \pm 1.5 dB)

At 7.5"/sec — 40 c/s to 15.000 c/s \pm 1 dB (50 c/s to 12.000 c/s \pm 1.5 dB)

2. Distortion:

2% of 3rd harmonic, 0.5% 2nd harmonic

3. Signal to Noise Ratio:

At 7.5" and 15" ips Record-Playback — 62.5 dB

4. Speeds:

The Nagra III has three operating speeds: 15", 7.5" and 3 $\frac{3}{4}$ ". The speed is changed by a switch.

5. Inputs:

There are two mixable inputs in the Nagra III, with two separate sensitivity control potentiometers.

Input No. 1 —

Sensitivity: 0.2 to 10 mv with 200 ohms microphone;

0.1 to 5 mv with 50 ohms microphone;

Input No. 2 —

Sensitivity: 0.5 to 10v with input impedance to 100 kohms

10 mv to 1v with input impedance of 2.5 kohms

6. Outputs:

Balanced line output: This line output is symmetrical.

With a load not less than 600 ohms + 4.4 volts (+14 dB)

7. Reels to be Used:

Standard Tape Reels up to 7" diameter (1200 feet length with regular tapes like the Scotch 111) with the cover open.

Up to 5" (600 feet Scotch 111) with the cover closed.

8. Power Requirements:

The recorder is operated with 12 D size batteries.

Power Consumption

in the TEST mode 85 ma.

In playback mode 175 ma.

In recording mode 205 ma.

9. Dimensions:

Dimension of casing 12.5" x 8.7" x 4.3" (318 x 222 x 112 mm).

Overall dimensions 14" x 9.5" x 4.3" (354 x 240 x 112 mm).

Weight of the recorder without batteries 13 lb, 13 oz (6.250 kg).

BATTERY DRIVEN CATHODE FOLLOWER

BRUEL & KJAER, TYPE 2630

SPECIFICATIONS

Input Impedance: 270 M Ω paralleled by 3 pF

Output Impedance: less than 300 Ω

Gain: 0.8 dB \pm 0.2 dB

Frequency Linearity: \pm 0.2 dB from 30 Hz to 20 kHz and with 50 pF at input \pm 1 dB from 20 Hz to 200 kHz. With 500 pF at input (e.g. an accelerometer) the response falls 1 dB at 3 Hz and 3 dB at 2 Hz.

Total Noise Level: (with 50 pF at the Input) in the range 20 c/s-35 kc/s: less than 35 uv (decreases when the battery voltage decreases).

Microphony: the signal-to-noise ratio is higher than 50 dB at 130 dB SL when used with a microphone cartridge having a sensitivity of 5 mV/ μ bar.

Distortion: less than 4% up to 200 kHz with input voltage 0.1 Volt and loaded by 1.1 m 30 pF.

Temperature Influence: less than \pm 0.4 dB in the range -5°C to $+50^{\circ}\text{C}$ ($+23$ to 140°F).

Storing temperature range: -10 to $+72^{\circ}\text{C}$.

Batteries: 3 Mallory cells type RM1 or RM 1-R.

Service life (with 8 hour service periods): 20 hours.

Weight with batteries and 3 meters cable: 0.6 kg.

Tube: CK 512 AX; *Transistors:* 2 x 2N2374.

CONDENSER MICROPHONES

BRUEL & KJAER TYPE 4131 (1")
TYPE 4133 (½")

SPECIFICATIONS

TYPE	4131	4133		
Nominal Cartridge Diameter	1 inch	½ inch		
Frequency Response* Flat within ±2 dB in the Range:	Free-field (0° incidence) 20 c/s to 18 kc/s	Free-field (0° incidence) 20 c/s to 40 kc/s		
Sensitivity* at cathode follower output	5mv/μbar -46 dB re 1 v/μbar	1mv/μbar -50 dB re 1 v/μbar		
Cartridge open-circuit sensitivity*	-45 dB re 1 v/μbar	-58 dB re 1 v/μbar		
Dynamic Range (from equivalent A-weighted noise level to 4% harmonic distortion)	15-146 dB re 0.0002 μbar	32-160 dB re 0.0002 μbar		
Resonant Frequency (90° phase angle)	10 kc/s	25 kc/s		
Polarization Voltage	200 v	200 v		
Polarized Cartridge Capacity*	70 pF	20 pF		
Equivalent Air Volume (at 1 atm)	0.15 cm ³	0.01cm ³		
Temperature Range: up to	100C	100 C		
Temperature coefficient between -50C and +60C	less than ±0.01 dB/C	less than ±0.01 dB/C		
Ambient Pressure Coefficient (increase of sensitivity for a 100 mm Hg decrease of pressure around 1 atm)	0.2 dB	0.1 dB		
Relative humidity influence	less than 0.1 dB (in the absence of condensation)			
Dimensions of cartridge:	diameter	height	diameter	height
without protecting grid	23.77 mm (0.936")	17 mm (0.67")	12.7 mm (½")	11 mm (0.43")
with protecting grid	23.77 mm (0.936")	19 mm (0.75")	13.2 mm (0.52")	12.7 mm (½")
Thread:			12.7 mm (0.50") - 60NS2	
grid (or coupler) mounting	23.11 mm (0.91") - 60NS2		11.7 mm (0.46") - 60NS2	
cathode follower mounting				

*Individually calibrated.

LINEAR SERVO ACCELEROMETER

DONNER TYPE 4310

SPECIFICATIONS

Nonlinearity: <0.05% of full range

Hysteresis & Nonrepeatability: <0.02% of full range

Resolution: <0.001% of f.r., 2.5 v \pm 1%

Temp. Coeff. of Null (of full range): 0.001% per F, 0.006% per F

Output Noise: <0.05% of full range in rms volts

Cross Axis Sensitivity (Referred to true sensitive axis): 0.0002 g/g of applied acceleration

Temp. Sensitivity of Scale Factor: 0.01% per F

Natural Frequency (90° Phase Shift) (dependent on g range): Electr. damped: 15-250 Hz at 25C,
Fluid damped: 60-150 Hz at 25C

<i>Damping Ratio:</i> Electr. damped:	0.4 to 0.7 \pm 0.1
	0.3 to 1 \pm 0.1
Fluid damped:	1 to 5 \pm 10% at 25C

Temperature Range: -60F to +200F storage
-40F to +200F operating

Shock Survival: 100 G 11 msec

Vibration Survival: 15 G rms, bandwidth 20 to 2000 Hz
(0.12 G² per Hz)

Case Alignment: \pm 1° to true sensitive axis

Output Current: 3 ma f.r.

Electrical Connections: 6 solder terminals

Weight: 4.5 oz electrically damped, 6 oz fluid damped

Physical Configuration: Rectangular aluminum case

Range: \pm 0.5 G to \pm 35 G

Input Power: \pm 15 vdc \pm 10% at 10 ma maximum

Voltage Output - Nominal: \pm 7.55 vdc full scale, \pm 1%

Output Impedance: 5 k nominal

PISTONPHONE BRUEL & KJAER, TYPE 4220

SPECIFICATIONS

Accuracy: ± 0.2 dB

Sound Pressure Level: 124 dB re $2 \times 10^4 \mu\text{bar}$ (individually calibrated)

Frequency: Pos. "Measure": 250 Hz \pm
Pos. "Check": 350 to 400 Hz (with new batteries)

Distortion: Less than 3% at 250 Hz

Batteries: 7 Mallory RM-3(R) mercury cells supplied. (B&K part No. QB 0002) Diameter 25.1 mm (0.98"). The battery compartment can also fit RM-4(R) cells (diameter 30.2 mm 1.19"), giving 50% longer service life.

Temperature Range: Batteries: 0-60C (32-140F)
Pistonphone alone: -40 to 60C (-40 to +140F)

Humidity: Relative humidities of up to 100% will not influence the calibration.

Dimensions: Length: 250 mm (9"). Diameter: 36 mm (1.4").

Weight: Pistonphone with batteries: 0.7 kg (1.5 lbs.)
Total weight of the case containing pistonphone, adaptors, and barometer 1.6 kg/35 lbs.