



DTIC
ELECTE D
DEC 05 1995
B

DISTRIBUTION STATEMENT A
Approved for public release;
Distribution Unlimited

19951128 088

**MEDICAL DEPARTMENT
UNITED STATES ARMY
IN WORLD WAR II**

DTIC QUALITY INSPECTED 5



MEDICAL DEPARTMENT, UNITED STATES ARMY

SURGERY IN WORLD WAR II

NEUROSURGERY

Volume II

Prepared and published under the direction of

Major General S. B. HAYS

The Surgeon General, United States Army

Editor in Chief

Colonel JOHN BOYD COATES, Jr., MC

Editors for Neurosurgery

R. GLEN SPURLING, M.D. BARNES WOODHALL, M.D.

Associate Editor

ELIZABETH M. McFETRIDGE, M.A.

OFFICE OF THE SURGEON GENERAL

DEPARTMENT OF THE ARMY

WASHINGTON, D.C., 1959

SURGERY IN WORLD WAR II

Advisory Editorial Board

MICHAEL E. DeBAKEY, M.D., *Chairman*

FRANK B. BERRY, M.D.	JOHN B. FLICK, M.D.
BRIAN BLADES, M.D.	FRANK GLENN, M.D.
J. BARRETT BROWN, M.D.	M. ELLIOT RANDOLPH, M.D.
STERLING BUNNELL, M.D. (dec.)	ISIDOR S. RAYDIN, M.D.
NORTON CANFIELD, M.D.	ALFRED R. SHANDS, Jr., M.D.
B. NOLAND CARTER, M.D.	HOWARD E. SNYDER, M.D.
EDWARD D. CHURCHILL, M.D.	R. GLEN SPURLING, M.D.
MATHER CLEVELAND, M.D.	BARNES WOODHALL, M.D.
DANIEL C. ELKIN, M.D. (dec.)	ROBERT M. ZOLLINGER, M.D.

Colonel JOHN BOYD COATES, Jr., MC (ex officio)
Colonel DOUGLAS B. KENDRICK, MC (ex officio)
Colonel JOSEPH R. SHAEFFER, MC (ex officio)

The Historical Unit, United States Army Medical Service

Colonel JOHN BOYD COATES, Jr., MC, *Director*
Colonel OTHMAR F. GORIUP, MSC, *Executive Officer*
Colonel R. L. PARKER, MSC, *Special Assistant to Director*
Lieutenant Colonel R. J. BERNUCCI, MC, *Special Assistant to Director*
JOSEPHINE P. KYLE, *Special Assistant to Director*
Lieutenant Colonel C. A. PENDLYSHOK, MSC, *Chief, Special Projects Branch*
Major RAYMOND H. WHITE, MSC, *Chief, Promotion Branch*
DONALD O. WAGNER, Ph.D., *Chief, Historians Branch*
WILLA B. DIAL, *Chief, Editorial Branch*
LUCY W. LAZAROU, *Chief, Research and Archives Branch*
HAZEL G. HINE, *Chief, Administrative Branch*

U. S. GOVERNMENT PRINTING OFFICE: 1959

For sale by the Superintendent of Documents, U.S. Government Printing Office
Washington 25, D.C.

NEUROSURGERY

Volume II

Accession For	
NTIS GRA&I	<input checked="" type="checkbox"/>
DTIC TAB	<input type="checkbox"/>
Unannounced	<input type="checkbox"/>
Justification	
By _____	
Distribution/	
Availability Codes	
Dist	Avail and/or Special
A-1	

MEDICAL DEPARTMENT, UNITED STATES ARMY

The volumes comprising the official history of the Medical Department of the U.S. Army in World War II are prepared by the Historical Unit, U.S. Army Medical Service, and published under the direction of The Surgeon General, U.S. Army. These volumes are divided into two series: (1) The administrative or operational series; and (2) the professional, or clinical and technical, series. This is one of the volumes published in the latter series.

VOLUMES PUBLISHED

ADMINISTRATIVE SERIES

Hospitalization and Evacuation, Zone of Interior

CLINICAL SERIES

Preventive Medicine in World War II:

Vol. II. Environmental Hygiene

Vol. III. Personal Health Measures and Immunization

Vol. IV. Communicable Diseases Transmitted Chiefly Through Respiratory and Alimentary Tracts

Surgery in World War II:

General Surgery, vol. II

Hand Surgery

Neurosurgery, vol. I

Ophthalmology and Otolaryngology

Orthopedic Surgery in the European Theater of Operations

Orthopedic Surgery in the Mediterranean Theater of Operations

The Physiologic Effects of Wounds

Vascular Surgery

Miscellaneous:

Cold Injury, Ground Type

United States Army Dental Service in World War II

Contributors

ELDRIDGE H. CAMPBELL, Jr., M.D. (deceased)

Formerly Colonel, MC, AUS; late Professor of Surgery, Albany Hospital, Albany, N.Y.

EDMUND JOHN CROCE, M.D.

Chief, Surgical Division, Worcester City Hospital, Worcester, Mass. Formerly Major, MC, AUS.

FRANCIS ASBURY ECHLIN, M.D., C.M., M. Sc., Med. Sc. D., F.A.C.S.

Professor of Clinical Neurosurgery, New York University-Bellevue Medical Center, New York, N.Y. Formerly Major, MC, AUS.

FREDERIC H. LEWEY, M.D. (deceased)

Formerly Lieutenant Colonel, MC, AUS; late Professor of Neuroanatomy and Associate Professor of Neuropathology, Graduate School of Medicine, University of Pennsylvania, Philadelphia, Pa.

WILLIAM R. LYONS, Ph. D., M.D.

Professor of Anatomy, University of California, School of Medicine, San Francisco, Calif. Formerly Captain, MAC, AUS.

WILLIAM K. MASSIE, M.D.

Orthopedic Surgeon, Lexington, Ky. Major, U.S. Army Reserves.

DONALD D. MATSON, M.D.

Associate Clinical Professor of Surgery, Harvard Medical School; Neurosurgeon, Children's Medical Center; Neurological Surgeon, Peter Bent Brigham Hospital, Boston, Mass. Formerly Major, MC, AUS.

FRANK H. MAYFIELD, M.D., F.A.C.S., A.B.N.S.

Assistant Professor of Clinical Surgery, College of Medicine, University of Cincinnati; Director of Department of Neurosurgery, The Christ Hospital and Good Samaritan Hospital, Cincinnati, Ohio. Formerly Lieutenant Colonel, MC, AUS.

WADE C. MYERS, Jr., M.D.

Chief of Surgery, Tampa General Hospital, Tampa, Fla. Formerly Captain, MC, AUS.

FRANK E. NULSEN, M.D.

Professor of Neurosurgery, Western Reserve University School of Medicine, Cleveland, Ohio; Chief of Neurosurgery, University Hospitals of Cleveland, and Senior Consultant in Neurosurgery, Crile Veterans' Administration Hospital. Formerly Captain, MC, AUS.

FREDERICK M. OWENS, Jr., M.D.

Clinical Associate Professor, University of Minnesota School of Medicine, Minneapolis, Minn. Assistant Chief, Neurosurgery, McCloskey General Hospital, Temple, Tex. Formerly Major, MC, AUS.

STANLEY E. POTTER, M.D.

Assistant Professor of Surgery, University of Nebraska College of Medicine, Omaha, Nebr. Formerly Captain, MC, AUS.

GEORGE C. PRATHER, M.D., F.A.C.S.

Assistant Clinical Professor of Surgery, Harvard Medical School, Boston, Mass. Head of Department of Urology, Beth Israel Hospital, Boston, Mass. Formerly Lieutenant Colonel, MC, AUS.

ROBERT T. ROSENFELD, M.D.

Attending Orthopedic Surgeon, Cedars of Lebanon Hospital, Mount Sinai Hospital, Los Angeles County General Hospital, Los Angeles, Calif. Fellow, American College of Surgeons, International College of Surgeons, American Academy of Orthopedic Surgeons. Formerly Major, MC, AUS.

R. GLEN SPURLING, M.D.

Professor of Neurosurgery, University of Louisville School of Medicine, Louisville, Ky. Formerly Colonel, MC, AUS.

T. CAMPBELL THOMPSON, M.D.

Surgeon in Chief, Hospital for Special Surgery, Professor of Clinical Surgery (Orthopaedics), Cornell Medical Center, New York, N.Y. Formerly Colonel, MC, AUS.

WILLIAM P. VAN WAGENEN, M.D.

Associate Professor of Neurological Surgery, University of Rochester School of Medicine and Dentistry, Rochester, N.Y. Formerly Lieutenant Colonel, MC, AUS.

WARNER WELLS, M.D.

Assistant Professor of Surgery, University of North Carolina School of Medicine, Chapel Hill, N.C. Formerly Consultant in Surgery to The Surgeon General, Department of the Army. Formerly Lieutenant Colonel, MC, AUS.

BENJAMIN BRADFORD WHITCOMB, M.D.

Visiting Neurosurgeon, Hartford Hospital, Hartford, Conn. Assistant Clinical Professor of Surgery (Neurology), Yale University, New Haven, Conn. Formerly Major, MC, AUS.

BARNES WOODHALL, M.D.

Professor and Chairman of the Division of Neurosurgery, Duke University School of Medicine, Durham, N.C. Formerly Lieutenant Colonel, MC, AUS.

Foreword

The first volume of the history of neurosurgery in World War II, which was published in 1958, dealt with the administrative aspects of this specialty and with the management of head injuries and their residua. This second (and final) volume in the neurosurgical series deals with injuries and diseases of the spine and peripheral nerve injuries.

The management of injuries of the spinal cord had been among the more dismal chapters in the medical history of World War I. The management of these injuries is, however, among the more brilliant chapters of the medical history of World War II. The paraplegic program, which is described in detail in this volume, was, and remains, an example of good medicine and of perceptive and compassionate care of men who otherwise would have been bedridden cripples all of their lives if, indeed, they had survived. Without this program, most of them would probably have died, partly because of their injuries and partly because they would have had nothing to live for. This program, which was instituted in Army hospitals during the war, was, shortly after the war ended, taken over by the Veterans' Administration, in which it has been continued on much the same lines and with much the same success.

The story of herniated nucleus pulposus (rupture of the intervertebral disk) in World War II is an example of the flexibility which is possible by the intelligent application of intelligently conceived administrative regulations. Most of the neurosurgery performed in the first year of United States participation in the war was for this condition. By the end of the war, surgery for lesions of the intervertebral disk was confined almost entirely to those patients whose line of duty was "yes" and who desired the operation. The reversal of the original policy occurred because it had been found that few of the men operated on for this condition could be returned to full military duty. The excellent results achieved by surgery in civilian life were not being duplicated in military circumstances, chiefly because of the physical requirements of military duty and because the protection of a *locus minoris resistentiae* which is possible in civilian life is absolutely impossible in service. The time and efforts of medical officers and other medical attendants, including physiotherapists, as well as the hospital bed space formerly devoted to herniated nucleus pulposus, were therefore wisely diverted to those who would receive more benefit from them.

It had been expected, from the standpoint of the caseload, that head injuries would furnish the outstanding neurosurgical problem in World War II. As events turned out, the heaviest neurosurgical load was furnished by peripheral nerve injuries.

The management of these injuries represented a striking advance over the methods used in World War I. Primary nerve suture was not attempted, but, whenever possible, repair was instituted overseas, after debridement and healing of the soft-tissue wound. The place of repair was not important. What mattered was the timing. Nerves repaired within the optimum time period of 21 to 90 days after wounding were restored to functional usefulness in countless cases in which the plan of delayed surgery usually practiced in World War I would have left useless extremities.

The management of peripheral nerve injuries in the specialized neurosurgical centers described in the first neurosurgical volume had much to do with making these successful results possible. This was partly because of the concentration in the centers of a trained neurosurgical staff and specialized equipment. It was also because in these specialized centers there were immediately available neurologists; orthopedic, plastic, and vascular surgeons; and other specialists who were needed for the care of the numbers of patients with peripheral nerve injuries whose wounds required combined management.

The record of these peripheral nerve injuries has been preserved in the Peripheral Nerve Registry, which is described in detail in this volume. The followup of a very large number of these cases is recorded in the volume on peripheral nerve regeneration published in 1957 as a Veterans' Administration monograph. This monograph, of which Dr. Barnes Woodhall, coeditor of the neurosurgical volumes in the World War II medical history, is also a coeditor, is probably the most satisfactory followup of wartime injuries that has ever been accomplished.

Neurosurgery furnished a particularly brilliant chapter of military medicine in World War II. I should like to repeat here what I stated in the foreword to the first of the neurosurgical volumes, that the editors of this volume, Dr. Woodhall and Dr. R. Glen Spurling, and the authors of the various chapters have added to their wartime service in the Medical Corps by the time and effort which they have devoted to the preparation of this permanent record of their work.

S. B. HAYS,
Major General,
The Surgeon General.

Preface

The first volume of the history of neurosurgery in World War II, published in 1958, was devoted to the administrative details without which military medicine cannot function; the evolution of neurosurgical policies in their broad aspects; and head trauma, including certain of its immediate sequelae. This second and final volume of the neurosurgical history of World War II is concerned with injuries of the spinal cord and peripheral nerves. A chapter on lesions of the intervertebral disk is included.

Because of the classic work of Harvey Cushing on penetrating wounds of the brain, the chapters on this subject in the history of the Medical Department of the U.S. Army in World War I were exceedingly helpful in setting up the program for the management of head trauma in World War II. In sharp contrast, the World War I history was of little help to the clinician in the management of peripheral nerve injuries and injuries of the spinal cord incurred in combat in the Second World War. It is true that the invaluable laboratory experiments of Carl Huber on peripheral nerve suture were printed in full in it, but the clinical sections did little more than discourage the neurosurgeon in his attempt to eliminate or reduce disability from peripheral nerve injuries. As for major injuries of the spinal cord, the few paragraphs, devoted to them are merely a depressing statement of the futility of treatment for these casualties, most of whom, if they did not die soon after wounding, died soon afterward, within weeks or months.

The most dramatic achievement of the entire neurosurgical program in World War II was undoubtedly the new chapter which was written in the management of paraplegia. Maj. Gen. Norman T. Kirk, USA (Ret.), The Surgeon General of the Army when this program was put into effect, has this to say of what was accomplished in this program:

This was a splendidly conceived program. Many new things were accomplished for the paraplegic which had never been accomplished before in either military or civilian medicine. Until this program was adopted, his life expectancy was measured in months, chiefly because of ascending urinary tract infection and the loss of vital pints of blood serum which leaked from decubitus ulcers. As paraplegics lost appetite, weight, and strength, they also became susceptible to other infections.

All of this was changed by the paraplegic program, in which neurosurgeons, urologists, internists, orthopedic surgeons, plastic surgeons, nurses and ward attendants, dietitians, and physiotherapists worked as a team with a single-minded purpose and objective. Urinary tract infection was controlled. Automatic bladder function was established. Bedsores were closed surgically, so that blood serum losses were ended. Plastic surgery was also employed as necessary. Under an improved dietary regimen, the patients gained weight and strength. With the help of orthopedic surgeons and physical therapists, many of them became ambulatory.

There would be little disagreement with General Kirk's concluding statement, that more was achieved for the paraplegic in World War II, in comparison with his status in previous wars, than for any other type of casualty.

In the early months of the war, the methods of management of the intervertebral disk were carried over from accepted civilian practices which had been developed in this relatively new entity before World War II. The only new concept which arose from the Army experience was the futility of attempting to rehabilitate most of these patients for field duty by any means at our disposal.

Between the two World Wars, injuries to major peripheral nerve trunks had been handled by orthopedic and industrial surgeons as well as by neurosurgeons. These injuries are relatively uncommon, however, and, because of the scarcity of material, very few important clinical studies, and even fewer important experimental studies, had been concerned with their diagnosis, treatment, and prognosis.

When the United States entered World War II, it was fully realized that large numbers of peripheral nerve injuries would be encountered. Reports from various sources had indicated the frequency of these injuries in the experience of other belligerents during the first years of the war. Our British colleagues, however, were the only ones who had laid down a definite policy of management for them, and they had selected orthopedic surgeons to do the job.

One of the first medicomilitary questions which Maj. Gen. James C. Magee, USA (Ret.), then The Surgeon General of the Army, had to decide was who should be responsible for these injuries in the U.S. Army. With the advice and concurrence of his chief consultant in surgery, the late Brig. Gen. Fred W. Rankin, it was decided to make the management of peripheral nerve injuries a part of the neurosurgical program.

There were two compelling reasons for this decision. The first was that, when the United States entered World War II, it had a more abundant supply of trained neurosurgeons than any other country in the world. The second reason, which proved eminently sound, was that orthopedic surgeons would be so busily engaged in the treatment of enormous numbers of casualties with bone and joint injuries that they would have little time for setting up an effective program in another field, particularly as the planned program for peripheral nerve injuries envisaged not only the management of peripheral nerve trauma but also preparations for a longtime study of these injuries once the conflict had ended.

Throughout this second volume on neurosurgery in World War II, the reader will encounter many references to the Peripheral Nerve Registry set up in the Office of the Surgeon General in November 1944. It is ironical to record that the 5-year study of peripheral nerve regeneration after

repair,¹ which was the outgrowth of this Registry, should have been completed and published before the volume of the World War II history which tells the story of how the Registry came into being. The readers of this second neurosurgical volume are urged to consult this monograph on nerve regeneration. The two books, in a sense, complement each other, and to read only one of them and ignore the other would leave the story of peripheral nerve injuries in World War II only half told.

As in the first volume of the neurosurgical series, we wish to acknowledge our debt of gratitude to the authors of the various chapters of this volume. They produced them, often at a great sacrifice of time and energy, immediately after their separation from service. There is no better proof of their devotion to duty than that, when the project was revived 10 years later, they again gave freely of their time and effort to revise and correct their manuscripts and thus help to produce this volume.

R. GLEN SPURLING, M.D.
BARNES WOODHALL, M.D.

¹ Woodhall, Barnes, and Beebe, Gilbert W. (editors): *Peripheral Nerve Regeneration. A Follow-up Study of 3,656 World War II Injuries.* Washington: U.S. Government Printing Office, 1957.

Contents

	<i>Page</i>
FOREWORD.....	IX
PREFACE.....	XI

Part I

INJURIES OF THE SPINAL CORD

<i>Chapter</i>		<i>Page</i>
I	Historical Note (<i>Barnes Woodhall, M.D.</i>).....	3
II	The Zone of Interior (<i>Barnes Woodhall, M.D.</i>).....	5
	Evolution of Policies.....	5
	Personnel.....	6
	Supplies and Equipment.....	8
	Surveys of Paraplegic Centers.....	8
	Causes of Death.....	11
	Transfer of the Paraplegic Program to the Veterans' Administration...	13
III	The Mediterranean (Formerly North African) Theater of Operations (<i>Eldridge H. Campbell, Jr., M.D.</i>).....	19
	Incidence.....	19
	Surgical Policies.....	20
	Decubitus Ulcers.....	22
	Management of the Cord Bladder.....	22
	Hospital Management.....	22
	Evacuation.....	23
IV	The European Theater of Operations (<i>R. Glen Spurling, M.D.</i>).....	25
	Surgical Policies.....	25
	Transportation.....	29
	Decubitus Ulcers.....	29
	The Cord Bladder.....	30
V	The Management of Acute Compound Battle-Incurred Injuries of the Spinal Cord (<i>Donald D. Matson, M.D.</i>).....	31
	Historical Note.....	31
	Classification of Compound Injuries of the Spinal Cord.....	32
	First Aid Treatment.....	35
	Neurologic Examination.....	36
	Lumbar Puncture.....	38
	Roentgenologic Examination.....	39
	Laminectomy.....	41
	Postoperative Care.....	57

<i>Chapter</i>	<i>Page</i>
V The Management of Acute Compound Battle-Incurred Injuries of the Spinal Cord—Continued	
Care of the Bladder.....	61
Care of the Gastrointestinal Tract.....	63
Nutrition.....	63
Evacuation.....	63
Factors of Mortality.....	64
VI Urologic Aspects of Spinal Cord Injuries (<i>George C. Prather, M.D.</i>).....	67
The Status of the Bladder After Injury of the Spinal Cord.....	67
Progress of Recovery.....	68
Methods of Examination of the Bladder.....	72
Care of the Bladder.....	86
Surgical Measures.....	95
Bladder Training.....	98
Comparison of Methods of Bladder Management.....	98
Status of the Upper Urinary Tract After Injury of the Spinal Cord.....	100
Status of the Sex Organs After Injury of the Spinal Cord.....	101
Genitourinary Complications of Injuries to the Spinal Cord.....	101
Results of Treatment.....	114
Spinal Cord Injury in the Female.....	118
Military Policies.....	119
A Suggested Program of Management.....	123
Conclusions.....	124
VII The Management of Paraplegic Patients in Zone of Interior Hospitals (<i>Barnes Woodhall, M.D.</i>).....	127
Analysis of Cases.....	127
Preliminary and Continuing Examinations.....	129
Decubitus Ulcers.....	130
Nutrition and Diet.....	146
Bladder Function.....	151
Bowel Function.....	153
Personal Hygiene.....	157
Psychiatric and Emotional Considerations.....	158
Physical Reconditioning.....	162
Ambulation.....	164
Relief of Pain and Spasm.....	178
Rehabilitation.....	184
Results of Program.....	186
Physician and Patient.....	188
The Problem of Morale.....	190
VIII Management of the Ruptured Intervertebral Disk (Herniated Nucleus Pulposus) (<i>R. Glen Spurling, M.D.</i>).....	193
Historical Note.....	193
Development of Clinical Policies in the Zone of Interior.....	194
Development of Clinical Policies in Oversea Theaters.....	202

Part II

PERIPHERAL NERVE INJURIES

<i>Chapter</i>	<i>Page</i>
IX Historical Note (<i>Barnes Woodhall, M.D.</i>).....	207
Peripheral Nerve Injuries in World War I.....	207
X The Zone of Interior (<i>Barnes Woodhall, M.D.</i>).....	211
Early Nerve Repair.....	211
Diagnostic Procedures.....	212
Nerve Grafting.....	218
Management of Causalgia.....	219
Neuropathologic Studies.....	219
Disposition.....	221
Peripheral Nerve Registry.....	225
XI The Mediterranean (Formerly North African) Theater of Operations (<i>Eldridge H. Campbell, Jr., M.D.</i>).....	231
Evolution of Policies.....	231
Primary Repair of Peripheral Nerve Injuries.....	231
Early Nerve Suture.....	233
Statistical Data.....	237
XII The European Theater of Operations (<i>R. Glen Spurling, M.D.</i>).....	239
Evolution of Policies.....	239
Timing of Nerve Repair.....	239
Principles and Techniques.....	242
Combined Bone and Nerve Injuries.....	244
Physical Therapy.....	246
Statistical Data.....	247
XIII Standard Methods of Examination in Peripheral Nerve Injuries (<i>Frederic H. Lewey, M.D.</i>).....	251
General Considerations.....	251
Objectives of the Examination.....	252
Initial Investigations.....	253
Quantitative Examination of Sequence of Returning Motor Function.....	256
Quantitative Assessment of Strength of Muscles of Hand and Foot.....	256
Nerve Block To Eliminate Supplementary Movements.....	263
Handprints and Footprints.....	265
Electrodiagnosis.....	266
Sensibility Tests.....	266
Sensory Examinations.....	272
Qualitative Determination of Sequence of Returning Sensory Function.....	272
Qualitative Methods of Mapping Out Areas of Impaired Sensation.....	273
Quantitative Determination of Pain Sensation.....	273
Quantitative Determination of Superficial Pressure (Touch).....	275
Estimation of Number of Pain and Touch Points.....	276
Nerve Block To Eliminate Overlap Sensation.....	277
Localization of Returning Sensation.....	277
Compass Test (Special Discrimination Test, Two-Point Test).....	277
Sweat Tests.....	279
Skin Temperature Test.....	280
Case Histories.....	283

<i>Chapter</i>	<i>Page</i>
XIV Anatomic Approaches to the More Commonly Injured Peripheral Nerves (<i>Warner Wells, M.D., Frederick M. Owens, Jr., M.D., and Francis A. Echlin, M.D.</i>).....	301
Historical Note.....	301
General Considerations.....	304
The Brachial Plexus.....	305
The Musculocutaneous Nerve.....	313
The Axillary Nerve.....	317
The Radial Nerve.....	318
The Median Nerve.....	328
The Ulnar Nerve.....	335
The Femoral Nerve.....	343
The Sciatic Nerve and Its Terminal Divisions.....	350
XV Techniques of Peripheral Nerve Repair (<i>Benjamin Bradford Whitcomb, M.D.</i>).....	363
General Considerations.....	363
Arrangement of Operating Room.....	364
Preoperative Preparation.....	365
Anesthesia.....	368
Incision and Exposure.....	369
Evaluation of the Status of the Nerve.....	372
Neurolysis.....	374
Techniques of Repair.....	375
Special Techniques.....	377
Steps of the Operation.....	382
Other Methods of Anastomosis.....	389
Regional Injuries.....	391
XVI Combined Bone and Peripheral Nerve Injuries (<i>Wade C. Myers, Jr., M.D., and Robert T. Rosenfeld, M.D.</i>).....	415
General Considerations.....	415
Selection of Cases for Combined Operation.....	416
Preoperative Management.....	420
Operation.....	421
Analysis of Data.....	422
Postoperative Complications.....	426
Results.....	428
XVII Peripheral Nerve Injuries Complicated by Skin and Soft-Tissue Defects (<i>Stanley E. Potter, M.D., and Edmund John Croce, M.D.</i>).....	429
Evolution of Policies.....	429
Routine of Management.....	429
Special Techniques.....	430
Postoperative Management.....	431
Conclusions.....	431
XVIII Peripheral Nerve-Vascular Injuries (<i>Barnes Woodhall, M.D.</i>).....	439
Incidence.....	439
Diagnostic Considerations.....	440

CONTENTS

XIX

<i>Chapter</i>	<i>Page</i>
XVIII Peripheral Nerve-Vascular Injuries—Continued	
Injuries of the Neck.....	441
Injuries of the Upper Extremity.....	448
Injuries of the Lower Extremity.....	455
Peripheral Nerve Injury With Vascular Occlusion.....	458
Management of Combined Vascular-Nerve Injuries.....	464
Other Associated Injuries.....	466
 XIX Causalgia Following Combat-Incurred Injuries of the Peripheral Nerves (<i>Frank H. Mayfield, M.D.</i>).....	 469
General Considerations.....	469
Incidence.....	470
Pathologic Process.....	473
Etiologic Considerations.....	474
Symptoms and Signs.....	478
Differential Diagnosis.....	485
Management.....	487
Results.....	489
 XX Peripheral Nerve Grafts (<i>Frank E. Nulsen, M.D., Frederic H. Lewey, M.D.,</i> <i>and William P. Van Wagenen, M.D.</i>).....	 493
General Considerations.....	493
Development of the Program.....	494
Materials and Methods.....	495
Indications.....	496
Technique.....	497
Evaluation of Results.....	499
Results.....	502
Summary and Conclusions.....	510
 XXI Neuropathologic Changes in Battle-Incurred Injuries of Peripheral Nerves (<i>William R. Lyons, Ph. D., M.D.</i>).....	 513
Materials and Methods.....	513
Time Lapse.....	514
Completely Severed Nerve Stumps.....	515
Severed Nerve Stumps in Fibrous Continuity.....	519
Neuromas in Continuity.....	519
Nerve Segment Eroded by Aneurysm.....	528
Suture Sites.....	531
Additional Studies.....	541
Comment.....	547
 XXII Physical Therapy in the Management of Peripheral Nerve Lesions (<i>Wil-</i> <i>liam K. Massie, M.D.</i>).....	 557
Changes in the Neuromuscular System Produced by Peripheral Nerve Injuries.....	 557
Diagnostic Aspects of Physical Therapy.....	559
Techniques of Physical Therapy.....	562
Psychologic Aspects of Physical Therapy.....	568

<i>Chapter</i>	<i>Page</i>
XXIII Orthopedic Techniques for Use in Irreparable Nerve Injuries (<i>T. Campbell Thompson, M.D.</i>).....	569
General Considerations.....	569
Operations on the Upper Extremity.....	571
Operations on the Lower Extremity.....	578
Conclusions.....	584
APPENDIXES	
A Army Service Forces Circular No. 25.....	587
B War Department Technical Bulletin 162.....	589
C Routine Procedure for Transverse Myelitis Cases.....	599
D Battle Wounds and Battle Injuries of the Spinal Cord and Vertebrae.....	609
E Peripheral Nerve Injury Study, All Nerves.....	611
F Peripheral Nerve Injury Study, Sciatic Nerves.....	633
INDEX.....	651

Illustrations

<i>Number</i>		
1	Colony type of paraplegia ward.....	10
2	Wheelchair mess for paraplegic patients.....	11
3	Roentgenograms showing shell fragment wound of spinal canal.....	20
4	Roentgenograms showing bullet wound of spinal canal.....	21
5	Roentgenograms showing fracture-dislocation of fifth cervical vertebra.....	26
6	Roentgenogram showing crush fracture of third lumbar vertebra.....	26
7	Roentgenogram showing shell fragment wound of cauda equina.....	27
8	Roentgenograms showing shell fragment wound of spinal canal.....	27
9	Common varieties of compound spinal wounds due to high-explosive missiles.....	34
10	Roentgenograms showing bullet wound of spine.....	40
11	Roentgenogram showing shell fragment wound of spine.....	41
12	Incisions for laminectomy.....	53
13	Surgical exposure of spinal wounds.....	53
14	Technique of laminectomy.....	54
15	Closure of wound of spine.....	54
16	Surgical exposure for hemilaminectomy.....	56
17	Position of paraplegic in bed.....	60
18	Position of paraplegic in bed.....	60
19	Cystometer.....	74
20	Cystometric curves of normal bladder.....	75
21	Cystometric curves of normal bladder.....	75
22	Cystometrogram of paraplegic bladder in first stage of recovery.....	76
23	Cystometrogram of paraplegic bladder in second stage of recovery.....	76
24	Cystometrogram of paraplegic bladder in third stage of recovery.....	77
25	Cystometrogram of paraplegic bladder with voluntary control.....	77
26	Cystometrogram of paraplegic bladder in third stage of recovery.....	78
27	Cystometrogram of paraplegic bladder with recovery still incomplete.....	78
28	Cystogram of paraplegic bladder in first stage of recovery.....	82
29	Cystogram of paraplegic bladder in stage of atony.....	83
30	Urethrogram of paraplegic in first stage of bladder recovery.....	84

CONTENTS

XXI

<i>Number</i>	<i>Page</i>
31 Urethrogram of paraplegic with complete cord transection.....	85
32 Urethrogram of paraplegic with good automatic bladder.....	86
33 Urethrogram of paraplegic with good bladder control.....	87
34 Urethrocystogram of paraplegic with sufficient bladder control to permit voluntary voiding.....	88
35 Diagram for closed system of bladder drainage and irrigation.....	92
36 Correct placement of suprapubic tube.....	96
37 Incorrect placement of suprapubic tube.....	96
38 Roentgenograms showing renal calculi in paraplegic.....	105
39 Intravenous urogram showing obstructing calculus in paraplegic.....	106
40 Roentgenograms showing ureteral calculi in paraplegic.....	107
41 Roentgenogram showing calculi in paraplegic.....	108
42 Multiple unilateral renal calculi in paraplegic.....	109
43 Roentgenogram showing bladder stone in paraplegic.....	110
44 Control record for paraplegic ward.....	130
45 Decubitus ulcers in paraplegic.....	132
46 Decubitus ulcers in paraplegic.....	133
47 Care of paraplegic on Stryker frame.....	136
48 Care of paraplegic on Stryker frame.....	137
49 Decubitus ulcer treated by skin graft.....	139
50 Plastic repair of decubitus ulcers.....	141
51 Plastic repair of decubitus ulcers.....	142
52 Plastic repair of decubitus ulcers.....	143
53 Plastic repair of decubitus ulcers.....	144
54 Plastic repair of decubitus ulcers.....	145
55 Roentgenograms showing neurogenic ossifying fibromyopathies in paraplegics..	148
56 Bedside setup for tidal drainage of bladder.....	152
57 Manometer used in typical tidal drainage of bladder.....	153
58 Instruction chart for use of tidal-drainage apparatus.....	154
59 Ward record for progress in genitourinary problems in paraplegics.....	155
60 Ward defecation record used in colony paraplegic care.....	156
61 Toilet guerney.....	157
62 Maximal physiologic position for defecation in paraplegia.....	157
63 Full sitting position on toilet seat achieved by paraplegic.....	158
64 Transfer from wheelchair to toilet by fully conditioned paraplegic.....	158
65 Toilet seat design for paraplegic.....	158
66 Washbasin arrangement for wheelchair-ambulant paraplegic.....	159
67 Bathing arrangements for wheelchair-ambulant paraplegic.....	159
68 Reconditioning at colony bed level by paraplegic.....	164
69 Mat exercises for paraplegics.....	166
70 Advanced exercises for paraplegics.....	168
71 Chair exercises for paraplegics.....	168
72 Brace fitting of paraplegic.....	169
73 Details of long leg brace for paraplegic.....	170
74 Brace fitting of paraplegic.....	171
75 Thoracopelvic girdle for paraplegic.....	172
76 Step-through gait in paraplegia.....	173
77 Swing-through gait in paraplegia.....	174
78 Swing-through gait in paraplegia.....	174
79 Use of overhead suspension track in early stage of ambulation in paraplegia...	175
80 Advanced step-through ambulation by paraplegic.....	176
81 Walking record used in paraplegic colony.....	177
82 Roentgenograms showing shell fragment in spinal canal.....	179

<i>Number</i>	<i>Page</i>
83	179
84	183
85	186
86	196
87	197
88	199
89	214
90	215
91	218
92	227
93	255
94	255
95	257
96	258
97	259
98	262
99	263
100	266
101	267
102	268
103	269
104	270
105	270
106	271
107	274
108	274
109	274
110	281
111	284
112	286
113	287
114	288
115	288
116	290
117	292
118	293
119	295
120	295
121	297
122	298
123	299
124	300
125	306
126	307
127	307
128	309
129	309
130	312

<i>Number</i>	<i>Page</i>
131 Surgical anatomy of musculocutaneous nerve.....	315
132 Skin incision for exposure of musculocutaneous nerve.....	315
133 Surgical exposure of musculocutaneous nerve.....	315
134 Skin incision for exposure of axillary nerve.....	319
135 Surgical anatomy of axillary space.....	319
136 Skin incision for exposure of axillary nerve.....	319
137 Surgical anatomy of axillary nerve.....	319
138 Surgical anatomy of radial nerve.....	321
139 Superficial cutaneous branches of radial nerve.....	321
140 Skin incision for exposure of radial nerve.....	323
141 Surgical exposure of radial nerve.....	323
142 Skin incision for exposure of radial nerve.....	324
143 Surgical exposure of radial nerve.....	324
144 Skin incision for exposure of radial nerve.....	324
145 Skin incision for exposure of radial nerve.....	327
146 Surgical exposure of deep radial nerve.....	327
147 Distribution of median nerve in arm.....	327
148 Terminal branches of median nerve.....	329
149 Course of median nerve.....	329
150 Skin incisions for exposure of median nerve.....	329
151 Cross section of arm showing relation of median nerve to neurovascular bundle..	332
152 Surgical anatomy of antecubital fossa.....	332
153 Motor branches of median nerve.....	332
154 Surgical exposure of median nerve.....	334
155 Cross section showing anatomy of median nerve in forearm.....	334
156 Surgical exposure of digital nerve in index finger.....	334
157 Flexion technique of bridging gap in median nerve.....	334
158 Stripping technique of achieving length in injury of median nerve.....	336
159 Technique of repair of median nerve.....	336
160 Distribution of ulnar nerve.....	337
161 Skin incision for exposure of ulnar nerve.....	339
162 Surgical exposure of ulnar nerve.....	341
163 Skin incision for exposure of ulnar nerve.....	341
164 Technique of anterior transplantation of ulnar nerve.....	344
165 Surgical anatomy of femoral nerve.....	345
166 Superficial cutaneous branches of femoral nerve.....	345
167 Relation of femoral nerve to vascular structures at Poupart's ligament.....	347
168 Skin incision for exposure of femoral nerve.....	348
169 Surgical exposure of femoral nerve.....	348
170 Skin incision for exposure of femoral nerve.....	350
171 Surgical exposure of femoral nerve.....	350
172 Schematic demonstration of origin, course, and main branches of sciatic nerve..	355
173 Anatomic approach to sciatic nerve.....	355
174 Exposure of sciatic nerve to gain length.....	357
175 Anatomic approach to common peroneal and tibial nerves.....	358
176 Anatomic approach to tibial nerve.....	360
177 Anatomic approach to peroneal nerve.....	361
178 Instruments for peripheral nerve surgery.....	366
179 Instruments and apparatus for peripheral nerve surgery.....	368
180 Closure of incision in peroneal nerve injury.....	370
181 Scars of healing by granulation after debridement in peripheral nerve injuries..	371
182 Incision for repair of ulnar nerve.....	372
183 Scar tissue in typical missile wounds of peripheral nerves.....	373

<i>Number</i>	<i>Page</i>
184 Nerve suture after extensive mobilization of proximal segment.....	377
185 Technique for repair of lateral neuroma.....	378
186 Optimum positions for flexion-relaxation of sutured nerves.....	379
187 End-to-end nerve suture.....	383
188 Resection of scarred portion of damaged nerve.....	385
189 Injection of distal nerve segment to facilitate anastomosis.....	386
190 Suture techniques of nerve repair.....	386
191 Suture techniques of nerve repair.....	387
192 Nerve suture site after removal of tantalum foil.....	388
193 Tantalum foil cuff.....	388
194 Postoperative roentgenogram showing tantalum sutures.....	390
195 Roentgenograms showing shortening of fractured humerus in repair of injury of radial nerve.....	405
196 Combined surgery in injury of humerus and radial nerve.....	424
197 Combined surgery in injury of humerus and radial nerve.....	425
198 Combined surgery in injury of radius, ulna, and median and ulnar nerves.....	426
199 Combined surgery in shell fragment wound of femur and sciatic nerve.....	427
200 Repair of injury of tibial nerve with soft-tissue loss.....	432
201 Repair of injury of tibial and peroneal nerves with soft-tissue loss.....	433
202 Repair of injury of tibial nerve with soft-tissue loss.....	434
203 Repair of injury of ulnar nerve with soft-tissue loss.....	435
204 Repair of injury of median nerve with soft-tissue loss.....	436
205 Repair of injury of ulnar nerve with soft-tissue loss.....	437
206 Repair of injury of radial nerve with soft-tissue loss.....	438
207 Paralysis of hypoglossal nerve.....	444
208 Paralysis of seventh nerve.....	444
209 Paralysis of spinal accessory nerve.....	447
210 Musculocutaneous and median nerve injury with axillary aneurysm.....	450
211 Paralysis of ulnar nerve with aneurysm of brachial artery.....	451
212 Aneurysm of brachial artery with ulnar and median nerve paralysis.....	452
213 Frozen hands after nerve-vascular injury.....	455
214 Popliteal aneurysm with sural nerve involvement.....	457
215 Frozen hand after nerve-vascular injury.....	460
216 Ischemic contracture of hand from nerve-vascular injury.....	461
217 Retention of function of hand after nerve-vascular injury.....	464
218 Patient with causalgia.....	480
219 Protection of causalgic hand.....	481
220 Serial demonstration of relief in causalgia.....	482
221 Oscillometric tracings in median nerve injury.....	483
222 Causalgic hand after median nerve injury.....	483
223 Oscillometric tracings in sciatic nerve injury.....	484
224 Method of keeping causalgic hand constantly moist.....	484
225 Roentgenograms showing spotty osteoporosis in causalgic limb.....	486
226 Successful frozen dried homograft applied to facial nerve.....	501
227 Successful frozen dried homograft applied to median nerve.....	504
228 Successful frozen dried homograft applied to median nerve.....	504
229 Successful frozen dried homograft applied to median nerve.....	505
230 Successful frozen dried homograft applied to median nerve.....	506
231 Unsuccessful application of frozen dried homograft to ulnar nerve.....	507
232 Unsuccessful application of frozen dried homograft to ulnar nerve.....	507
233 Unsuccessful application of frozen dried homograft to ulnar nerve.....	508

<i>Number</i>	<i>Page</i>
234 Unsuccessful use of frozen dried homograft.....	509
235 Unsuccessful use of frozen dried homograft.....	510
236 Unsuccessful use of frozen dried homograft.....	511
237 Unsuccessful use of frozen dried homograft.....	511
238 Successful autogenous nerve graft.....	512
239 Complete severance of ulnar nerve.....	516
240 Cross section of severed musculocutaneous nerve.....	517
241 Cross section of severed branch of femoral nerve.....	518
242 Complete severance of posterior tibial nerve.....	520
243 Complete severance of radial nerve.....	522
244 Cross sections of degenerated distal nerve segments.....	524
245 Neuroma of ulnar nerve.....	525
246 Surgical exposure of median nerve.....	526
247 Longitudinal section through neuroma in continuity of ulnar nerve.....	527
248 Longitudinal section through neuroma in continuity of ulnar nerve.....	527
249 Cross sections of common peroneal and posterior tibial nerves.....	528
250 Contusion of sciatic nerve.....	528
251 Neuroma in continuity of common peroneal nerve.....	529
252 Fusiform neuroma in continuity of ulnar nerve.....	530
253 Neuroma in continuity of ulnar nerve.....	531
254 Neuroma in continuity of ulnar nerve.....	532
255 Erosion of radial nerve by aneurysm.....	534
256 Giant cell and fibrous reaction around silk sutures in ulnar nerve.....	536
257 Fibrous reaction around site of tantalum sling suture.....	537
258 Section through suture site of median nerve.....	538
259 Anastomotic zone of common peroneal nerve after tantalum wire suture.....	539
260 Temporary repair of radial nerve with silk sling stitches and fibrin film wrapping.....	540
261 Cross section through fascicle of sutured radial nerve.....	542
262 Longitudinal section through fascicle of sutured ulnar nerve.....	542
263 Neuroma of ulnar nerve after repair with inadequate resection.....	544
264 Cross section through sutured median nerve.....	546
265 Complete severance of median nerve.....	548
266 Bulb suture of common peroneal nerve.....	550
267 Disruption of radial nerve after suture.....	551
268 Disruption of common peroneal nerve after suture.....	552
269 Stretch fibrosis of common peroneal nerve.....	553
270 Repair of radial nerve by sural autograft cables.....	554
271 Frozen dried homograft applied to posterior tibial nerve.....	555
272 Steindler technique of transplantation of flexor muscles.....	572
273 Steindler technique of transplantation of flexor muscles.....	572
274 Transplantation of flexors of forearm.....	575
275 Transplantation of flexors of forearm.....	575
276 Transplantation of flexor digitorum sublimis tendons in clawhand deformity.....	578
277 Transplantation of flexor sublimis tendon into thumb.....	578
278 Transplantation of flexor sublimis tendon into thumb.....	578
279 Lambrinudi operation to correct equinus and varus deformities.....	581
280 End result of Lambrinudi subastragalar arthrodesis.....	581
281 Transplantation of tibialis posticus for correction of equinovarus deformity.....	582
282 Transplantation of tibialis posticus for correction of equinovarus deformity.....	583
283 Transplantation of tibialis posticus for correction of equinovarus deformity.....	583

Color Plates

<i>Number</i>	<i>Page</i>
1 Cross section through fascicle of severed ulnar nerve.....	518
2 Cross section through fascicle of severed median nerve.....	518
3 Cross section through fascicle of severed median nerve.....	518
4 Cross section through fascicle of severed ulnar nerve.....	518
5 Longitudinal section through fascicle of severed sciatic nerve.....	518
6 Cross section through fascicle of severed median nerve.....	518
7 Cross section through fascicle of severed sciatic nerve.....	518
8 Longitudinal section through fascicle of segment of neuroma in continuity in posterior cord of brachial plexus.....	518
9 Longitudinal section through neuroma in continuity in common peroneal nerve.....	518
10 Longitudinal section through neuroma in common peroneal nerve.....	518
11 Longitudinal section through neuroma in continuity in median nerve.....	518
12 Longitudinal section through frozen dried homograft in tibial nerve.....	518

Tables

<i>Number</i>	
1 Status and disposition of paraplegics in December 1945.....	16
2 Distribution of 1,260 battle-incurred spinal cord injuries in United Kingdom hospitals.....	28
3 Specimen case fatality rates in surgery of spinal cord injuries.....	65
4 Status in 1944 of 1943 admissions for herniated nucleus pulposus.....	198
5 Cases of herniated nucleus pulposus operated on in 1943.....	201
6 Status in 1945 of 1943 admissions for herniated nucleus pulposus.....	202
7 Anatomic distribution of 1,184 peripheral nerve injuries in Mediterranean theater.....	237
8 Essential data in 6,245 peripheral nerve injuries in European theater.....	248
9 Average strength of motions of hospital population (in pounds).....	260
10 Skin temperature.....	282
11 Summarized data in 36 combined bone-nerve operations.....	417
12 Incidence of causalgia in neurosurgical centers.....	471
13 Essential data in 60 cases of causalgia.....	491
14 Results of frozen dried homografts in 5 partial peripheral nerve defects.....	499
15 Results of frozen dried homografts in complete peripheral nerve defects.....	502

Part I

INJURIES OF THE SPINAL CORD

CHAPTER I

Historical Note

Barnes Woodhall, M.D.

The policies employed in injuries of the spine and the results secured by them in World War I require no extended discussion. Only a few pages were devoted to them in the official history of World War I,¹ and the section dealing with their management in forward hospitals dismisses them in a single paragraph, as follows:

SPINAL CASES

These did very badly throughout, as was anticipated. Most of them were immediately evacuated to base hospitals and fully 80 percent died in the first few weeks in consequence of infection from bed sores and catheterization. The conditions were such, owing to pressure of work, as to make it almost impossible to give these unfortunate men the care their condition required. No water beds were available, and each case demands the almost undivided attention of a nurse trained in the care of paralytics. Only those cases survived in which the spinal lesion was a partial one.

Wounds of the bony spine were classified into (1) those without perforation of the dura or injury to the cord, (2) those without perforation of the dura but with injury to the cord, (3) those with perforation of the dura and injury to the cord, and (4) those with injury to the cord without external wounds (spinal concussion). Surgery was never considered for spinal concussion, and spinal lesions in which a transverse injury was suspected were also considered inoperable if they were complicated by serious wounds of the chest and abdomen.

The results of spinal injuries were described as extremely discouraging and the mortality as very high. In one series of 32 cases reported by Col. Harvey Cushing, MC, 8 were inoperable and there were 23 deaths (71.8 percent). Of the 24 patients operated on, 15 died (62.5 percent). All of these patients were cared for in forward areas, and the followup was inadequate because casualties with spinal cord injuries were evacuated promptly if they were regarded as at all transportable. The implication is that more deaths probably occurred in rear areas. Suture of the cord was stated to be "a vain and harmful procedure, as the added handling produces more injury. An injured cord can be cleansed, but not restored."

¹ (1) Cushing, Harvey: Organization and Activities of the Neurological Service, American Expeditionary Forces. *In* The Medical Department of the United States Army in the World War. Washington: Government Printing Office, 1927, vol. XI, pt. 1, pp. 749-758. (2) Hanson, Adolph M.: Management of Gunshot Wounds of the Head and Neck in Forward Hospitals, A.E.F. *In* The Medical Department of the United States Army in the World War. Washington: Government Printing Office, 1927, vol. XI, pt. 1, pp. 776-794.

The management of the bladder was never made a subject of specific instructions, and it was never decided whether intermittent catheterization or merely allowing the bladder to fill and overflow by dribbling was the better policy. The principal objective was to avoid infection, and from this standpoint there was something to be said for each of these plans. On the whole, the "let alone" policy was most favored in evacuation hospitals.

The sad record of spinal cord injuries in World War I can best be summed up in a paragraph from the official history which reads as follows:

* * * Many of these cases undoubtedly died soon after their evacuation to the rear. It was rather common to have men with spinal cord injuries arrive dead or dying. Injuries of the spine, perhaps, formed a much larger group than those computed from hospital records would lead one to think, as the serious wounds involving the chest and abdomen in which death occurred at the front, were undoubtedly in many instances, complicated by spinal injuries.

CHAPTER II

The Zone of Interior

Barnes Woodhall, M.D.

EVOLUTION OF POLICIES

Although during the prewar years civilian neurosurgeons had had some hopeful experiences in the treatment of paraplegia, it is lamentably true that, during the early months of World War II, both casualties arriving from overseas and those who had suffered their injuries in the Zone of Interior had very little encouragement offered them. Two factors were responsible. The first was the feeling of hopelessness inherited from World War I. The second was the administrative policy that these patients should be passed through the Army general hospital system as rapidly as possible and then discharged to the VA (Veterans' Administration) as inevitable casualties of the war. There was a strong feeling among some of the officers who had recently entered the Medical Corps from civilian practice that this admission of failure was not justified. It is significant that the changes which eventually produced one of the most striking advances in medical history were instigated by Col. (later Brig. Gen.) Fred W. Rankin, MC, Chief Consultant in Surgery, Office of the Surgeon General.

The recommendations which General Rankin made to The Surgeon General concerning the care of paraplegics were formally implemented in Circular No. 25, Headquarters, Army Service Forces, 22 January 1945 (app. A, p. 587). This circular specified (1) that paraplegic casualties should be retained in the Army general hospital system until maximum benefit had been achieved (p. 13), and (2) that they should not be transferred to the jurisdiction of the VA until their progress appeared to have leveled off and until it was unlikely that further substantial improvement would occur.

TB MED (War Department Technical Bulletin) 162 (app. B, p. 589) was issued in May 1945, after the neurosurgical centers designated for the care of paraplegics had assumed their responsibilities and had begun to assemble the diverse professional talent necessary for the management of these patients. The bulletin covered all phases of the new program. Its objectives were outlined in the first paragraph. After the warning that a defeatist attitude was intolerable in the care of patients with transverse myelitis, it was pointed out that the majority of these men could lead a wheelchair existence, at least; that many of them could be taught to walk

with braces and crutches; and that practically all of them could achieve self-support by means of some sedentary occupation, which should be regarded as the ultimate objective of all rehabilitation. It was further emphasized that it was the mission of general hospitals in the Zone of Interior to effect, before the final discharge of a paraplegic, a degree of rehabilitation for him "essential for the preservation of morale and human dignity."

The major problems encountered in the management of patients with traumatic paraplegia included the prevention of decubitus ulcers, the maintenance of a satisfactory nutritional status, the control of neurologic complications, the establishment of bladder function, and, as has just been described, the achievement of rehabilitation, a term which covered a variety of objectives. The management of these problems and the techniques of the new program are described elsewhere in this volume (p. 127). They were all at Newton D. Baker General Hospital, Martinsburg, W. Va., on 11-12 May 1945; at Hammond General Hospital, Modesto, Calif., on 24-25 June 1945; and at Halloran General Hospital, Staten Island, N.Y., and Thomas M. England General Hospital, Atlantic City, N.J., on 19-20 October 1945.

PERSONNEL

Organization.—An efficiently operated paraplegic program required the support of practically every section in the hospital. More important, however, than securing the formal support of the various services was securing the understanding help and cooperation of everyone associated with the patients in any way at all and particularly those in constant, intimate association with them.

At the inception of the program in each hospital, it was found useful to assemble the ward personnel, including nurses, nurses' aides, wardmasters, and ward attendants, and explain to them in detail the objectives and techniques of the program. The explanations covered the methods employed in the restoration of bladder and bowel function, the care of decubitus ulcers, the importance of adequate nutrition, and the other clinical responsibilities which ward personnel must assume. The explanation also included the mental and somatic approach to these patients and the extreme importance of the psychologic encouragement which those who cared for them could best supply.

Conferences between ward officers and ward personnel were held thereafter at regular intervals as well as when special problems arose. All personnel were made to feel that suggestions were welcome. Initiative was thus fostered, and many helpful changes in treatment or additions to the regular ward routines were introduced in this way.

Selection and training.—Unfortunately, trained personnel were always in short supply. At an occasional hospital, as Col. Loyal Davis, MC, mentioned in a survey of paraplegic centers which he made early in 1945,

medical officers, physical therapists, nurses, orderlies, and social service personnel were so numerous that "there was an average of 1 such person for each patient throughout the 24 hours."

This was not generally true. For one thing, personnel assigned to the care of paraplegic patients had to be of a very special type. For another, as all chiefs of services lamented, constant changes of personnel could undo a program which had been carefully planned and in which there had been every reason to anticipate success. As Col. Russel H. Patterson, MC, said in discussing this phase of the program at the Hammond conference on transverse myelitis in June 1945—

One group of corpsmen is uninterested in this type of patient and would rather not take care of them. Another mixed group is untrained and it would take too long to train them to be the kind of attendants who should be assigned to this job. You cannot take corpsmen who have been field sergeants at Guadalcanal and Okinawa and put them on a ward to take care of any sick patient, let alone paraplegics. They don't fit. Also if you have a corporal who does wonderful work with these cases supervised by a top sergeant who knows nothing about them, this tends to break morale.

The same thoughts were expressed by other chiefs of paraplegic services at this conference and at others. There was general agreement that the professional and nonprofessional personnel assigned to these wards must be a select group, intelligent, well trained, and, above all, enthusiastic and interested. At the Hammond conference, there was serious discussion of the possible necessity of establishing a school at some one of the paraplegic centers for the training of personnel for this special work.

As Lt. Col. (later Col.) Ambrose H. Storck, MC, saw the problem, it was one that would continue for many years. Work with these patients could be done only by physicians who were genuinely interested and who were willing to devote years of their lives to it. Even the reconditioning and physical therapy requirements of this group differed from those of "run-of-the-mill, short-term, less serious cases." Educational and vocational planning and training must be on a long-term basis.

The end of the war in the Pacific and the transfer of paraplegic patients to the VA within the following months (p. 13) relieved the Army of the responsibility for these patients. Otherwise, the increasing necessities of the paraplegic program would probably have required the setting up of such a training center as had been proposed and the recruitment of a greatly increased number of personnel with special qualifications to staff the centers.

The efficient use of personnel required that nurses, nurses' aides, aidmen, and civilian personnel must not only understand the program and its purposes but also must understand their own duties. When WAC's were first assigned to the program in early 1945, they served competently, but in the beginning there was considerable confusion because their duties and their hours of work were not clearly specified by regulations. As Colonel Patterson said at the Hammond conference—

* * * * *

When WAC's began to replace corpsmen, the question arose as to how long they were to work. The answer was 8 hours, the same as nurses. When you mentioned it to the top sergeant, he said 12 hours, the same as corpsmen. It was some time before we got all of this straight at Bushnell. Paraplegic wards are complicated, and things like this cannot be left to chance.

Colonel Patterson, as well as others, also mentioned the effect on military morale of the wages paid to civilian employees, sometimes more than twice as much as WAC's and aidmen were receiving. Also under discussion was the effect of blanket promotions of newly assigned personnel on individuals who had given long and faithful service and who did not receive promotions.

In spite of the personnel difficulties which beset the paraplegic program throughout the war and, indeed, as long as the Army was responsible for it, the care which these patients received was of the highest type. It was not only technically competent. It was also truly devoted.

SUPPLIES AND EQUIPMENT

Supplies in paraplegic centers were sometimes slow in arriving, but, on the whole, they were excellent, efficient, and adequate. Because of the special necessities of these patients, many of the items required for their care were not in the supply catalog and had to be purchased as nonstandard items. How rapidly the supplies could be secured depended chiefly upon the understanding and cooperation of the hospital commanders, most of whom were sympathetic and helpful. In a surprising number of cases, lack of formal equipment and temporary shortages were overcome by the ingenuity of professional and nonprofessional personnel, who devised ingenious substitutes.

To the end of the war, there was no general agreement on the type of bed best for paraplegics. A hard bed, a bed with inner springs, and an air mattress were all used with varying degrees of success.

Air conditioning was almost essential in the management of paraplegics but was difficult to accomplish during wartime conditions. In May 1945, General Rankin called this fact to the attention of the director of the Hospital Division, Office of the Surgeon General, and recommended that steps be taken at once to provide it for the 20 paraplegic centers then in operation. If this was impossible, he recommended that separate units be installed in the paraplegic wards. If air conditioning could not be accomplished immediately by a general system or by local units, he recommended that first priority be given to hospitals located in portions of the country in which the summers were uncomfortably warm. As the result of this recommendation, air conditioning was installed in the paraplegic ward of Newton D. Baker General Hospital and certain other centers.

SURVEYS OF PARAPLEGIC CENTERS

Visits to the various paraplegic centers by the Consultant in Neurosurgery, Office of the Surgeon General, revealed conditions ranging from

good to superb. No neurosurgical condition encountered in World War II was handled with more technical competence, skill, and understanding than paraplegia, as is shown by the following (summarized) reports, which are entirely typical.

Newton D. Baker General Hospital

A visit to Newton D. Baker General Hospital in September 1945 showed that the physical environment for the care of paraplegics was almost ideal. The ward, which was without partitions, was air conditioned. There were special wards for officers and a number of small rooms in which seriously ill patients could be cared for. The beds were arranged around the periphery of the ward in colony style (fig. 1). All were equipped with Balkan frames and exercise bars. There were specially constructed bedside tables for the patients' personal belongings. Wheelchairs and walkers were in generous supply, so that the patients could be kept out of bed for large parts of the day (fig. 2). Ward officers had their own office. The treatment rooms were well equipped with the special equipment necessary for paraplegics. Excellent diets were served attractively from a well-equipped kitchen.

In addition to the urologic problems, all competently handled by Capt. (later Maj.) Boris P. Petroff, MC, chief of the urologic service, there were three other main problems, as follows:

1. *Decubitus ulcers*.—Initial attempts at secondary closure of these ulcers had been so successful that a plastic surgeon, Capt. (later Maj.) Donald E. Barker, MC, was assigned to assist in the management of these cases. At the time of the inspection, every ulcer had been closed by secondary suture, by rotation of skin flaps, or by skin grafts. This was a monumental accomplishment. The protein deficit which played such an important part in decubitus ulcers was fully appreciated, and dietetic and other measures were entirely adequate.

2. *Control of pain*.—In many cases, this was a problem which was hard to overcome. The chief measures employed were removal of retained foreign bodies, excision of scar tissue from lesions in the cauda equina, and spinothalamic cordotomy.

3. *Control of spastic reflexes*.—These were attacked by all known methods, including nerve crushing, the administration of curare in a few cases, and in three instances, anterior rhizotomy.

McCaw General Hospital

When the paraplegic center at McCaw General Hospital, Walla Walla, Wash., was visited in September 1945, there were approximately 50 patients in it, about 45 of whom had been treated by laminectomy overseas. The ward setup was excellent, and practically all the equipment necessary for the competent management of these patients had been provided, including a full supply of Stryker frames. The only real lack was a swimming pool.

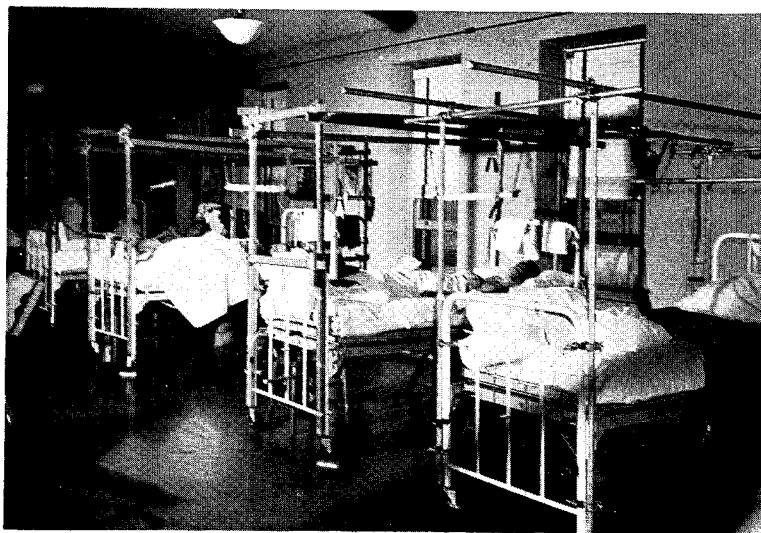

FIGURE 1.—Colony type of paraplegia ward equipped with Balkan frames and exercise bars and typical of wards in all World War II paraplegia centers.

Most of the patients had had extensive decubitus ulcers on their arrival, and many of the lesions had presented real problems of management. Treatment had consisted of elevation on the Stryker frame, the application of zinc peroxide, and the usual general measures, including a high-protein component in the diet. Surgery was resorted to as indicated. The possibility of a secondary breakdown after the healing of extensive lesions was fully appreciated, and, when healing had occurred spontaneously, it was the rule to excise scars and perform sliding or undermining operations, to provide soft-tissue coverage for bony prominences. The stamp type of Thiersch's graft proved most satisfactory for this purpose.

Pain and spasm were usually controlled by standard measures, but curare in various preparations had been used in seven cases, in all of which spasm was particularly troublesome. Relief was of varying duration. In one instance it had lasted for 72 hours. Even when it lasted no longer than 6 or 7 hours, however, this interval provided an opportunity for physical therapy, which could not be employed when spasticity was continuous. Attempts to develop an oil solution or a suspension, in order to prolong the action of the curare, had not been successful. The best response to this measure was observed in patients who had the most pain associated with spasm. In one or two cases in which the dosage of curare had not been sufficient to relax spasm notably, the relief of pain was quite pronounced.

With the enthusiastic cooperation of the orthopedic service, ambulation was accomplished in most patients. Braces were fitted as necessary. Mass sports, which were part of the reconditioning program, provided wholesome recreation.



FIGURE 2.—Wheelchair mess for paraplegic patients in advanced reconditioning group.

At this paraplegic center, there was a particularly praiseworthy attempt to train the patients for future life. A number undertook courses at Whitman College, Walla Walla, Wash., which was adjacent to the hospital, or continued their previous scholastic training there. One soldier who had been taking law before he entered the Army resumed his legal training. Occupational therapy was directed to practical ends. It included typing, watch repairing, key making, and other useful occupations.

As at all centers, the warm interest of the medical officers and other personnel in their patients had much to do with this highly successful program.

CAUSES OF DEATH

In spite of the serious condition of many paraplegics, fatalities in paraplegic centers were remarkably few. Most of them were attributable to urinary tract infection or its complications.

The report of six necropsies at the paraplegic center at Nichols General Hospital, Louisville, Ky., by Capt. (later Maj.) Henry Rappaport, MC, may be assumed to be typical. In these six cases, infection of the urinary tract or complications of the infection were responsible for five of the deaths. In the sixth case, death was caused by complications of a deep sacral decubitus ulcer.

There was a certain common pattern in these six cases. All the patients were extremely emaciated. All had severe secondary anemia. Every post mortem examination revealed a type of inflammation which had spread by

direct extension, without respect for such anatomic barriers as fascia, periosteum, or the serosal membranes or the capsules of viscera. The appearance of the inflammation strongly suggested a pronounced decrease of general and local resistance to infection. The lack of resistance was further evidenced by the type of organisms found in three cases, in which pure cultures of gram-negative bacilli were recovered from blood taken at autopsy. The same organisms were also found in the local lesions. In spite of the usual low pathogenicity of the organisms of the *coli-aerogenes* group, these organisms were apparently able to cause continued suppuration and septicemia in these debilitated patients.

Previous studies had shown that resistance to infection is considerably decreased in hypoproteinemia and that, once infection develops, the regeneration of blood protein is much more difficult. In all of these fatal cases, anorexia was pronounced, and the food intake was entirely inadequate. Captain Rappaport therefore suggested that the type of inflammation found in these necropsies was chiefly due to lack of resistance, particularly lack of tissue resistance, caused by severe protein depletion of the tissues. He cited the work of Elman and others to the effect that the reduction of tissue protein is always more severe than is indicated by the plasma protein values (p. 147).

The findings in these six cases suggested a causal relation between the degree of protein deficiency and the extent and severity of the inflammatory process. Captain Rappaport's suggestion was that a vicious circle was thus established, whereby hypoproteinemia decreases resistance to infection, and, once infection develops, the regeneration of body proteins becomes more difficult, and a fatality may result.¹

¹ Editor's Note: Dr. Harry Kessler wrote an article entitled "Traumatic Paraplegia, Rationale of Therapy" which was published in the *Annals of Internal Medicine*, volume 40, pp. 905-923, May 1954. According to Kessler, writing from the central office of the VA in Washington, D.C., 2,949 patients with traumatic paraplegia (including quadriplegics) were admitted to hospitals of the VA system between 1 Jan. 1946 and 31 Dec. 1950. In this group, there were 226 deaths; 102 occurred in 1946, 31 in 1947, 46 in 1948, 24 in 1949, and 23 in 1950. It was cautiously concluded that after the first year of his disability, the paraplegic, having come safely through the initial period of spinal shock, has a better chance for survival. This report does not specify causes of death, but Kessler was impressed with the frequency with which renal insufficiency appeared as a precursor of the fatality. The extensive amyloidosis also apparent in some of these fatal cases was not surprising, since the life of the paraplegic is punctuated by recurrent bouts of infection and malnutrition.

Later (in September 1955), a survey was made of the 5,743 patients treated in VA hospitals between 1 Jan. 1946 and 30 Sept. 1955 for traumatic injury of the spine resulting in paraplegia or quadriplegia. It revealed that 590 paraplegic and 212 quadriplegic patients had died at some time after their first episode of treatment in these hospitals.

When the survival experience was studied in relation to age, taking into consideration the time elapsed between injury and the beginning of treatment in a VA hospital, it was found that the age at the time of injury was an extremely important factor. Younger patients, whether their injuries caused paraplegia or quadriplegia, had a better chance of survival. As might have been expected, the paraplegic patient was found, in general, to have a better chance of survival than the quadriplegic. It was interesting to observe, however, that quadriplegics with partial lesions who were under 25 years of age at the time of injury had about the same survival experience as the paraplegic with a partial lesion in the same age group. The 10-year survival experience of both paraplegics and quadriplegics showed a decrease in the percentage of survivors as the age of the patients increased.

It is still not possible to determine whether the paraplegic or quadriplegic patient has a different mortality experience from that of the nonparaplegic veteran of similar age, but, by use of the

TRANSFER OF THE PARAPLEGIC PROGRAM TO THE VETERANS' ADMINISTRATION

Early Planning—1945

The policy set up in World War II that no patients should be discharged from Army hospitals to the care of the VA until they had received maximum hospitalization benefits introduced difficulties of interpretation in a number of conditions, one of which was transverse myelitis. Army Service Forces Circular No. 25, 22 January 1945 (app. A, p. 587) attempted to clarify the requirement, as follows:

1. Wounds and pressure sores should be completely healed and no further surgery should be anticipated.
2. Every attempt should have been made to establish an automatic bladder, eliminate bladder infection, and establish satisfactory bowel function.
3. Every effort should have been made to achieve restoration of muscular function in lower extremities by physical therapy, braces, crutches, and other devices such as walkers.
4. Patients should be discharged to the jurisdiction of the VA only when these requirements had been met as far as possible, when progress had leveled off, and when no further substantial improvement could be anticipated.

On a number of occasions during the first part of 1945, The Surgeon General further clarified the interpretation of maximum hospital benefits by stating that patients with paraplegia who gave any promise of continuing improvement should be retained in Army hospitals until no further substantial improvement could be expected.

At the paraplegic conferences held while the war was in progress, there was considerable discussion about the future management of these patients. Many of the medical officers who were caring for them envisaged paraplegic centers especially built as well as especially equipped and staffed. The discussions covered the location (in a temperate climate, within reasonable proximity to an industrial center as well as near medical and educational facilities); the type of building (one story, close to the ground or with adequate elevators); specialized professional personnel (in neurosurgery, urologic and orthopedic surgery, general surgery, and internal medicine); other personnel (in sufficient numbers and qualitatively recruited); physical

1949-51 life tables for the white male population of the United States, certain observations were possible. The differential mortality increased with advancing age. For example, for every 100 study patients under 25 years of age at the onset of the injury, 84 percent survived for 10 years, as contrasted to an estimate of 98 percent for the general population of comparable age. The differential, or added, risk of death is therefore 14 percent at the end of 10 years. This differential was found to be 18 percent for paraplegics in the 25- to 34-year group, 24 percent in the next decade, and 40 percent in the 45- to 59-year group. The mortality experience for quadriplegics was similar except that the differentials were larger than those observed for paraplegics.

The VA has under consideration the preparation of a book covering all aspects of spinal cord injury. Such a volume would be a fitting complement to the wartime experience, emanating, as it would, from hospitals which have acquired a significant experience in the handling of patients with this disability.—B. W.

reconditioning (requiring special personnel, special facilities, and brace-shops); and research. The clue to the successful operation of such a center would be its personnel, persons with interest in, and appreciation of, the problems of the paraplegic, centering from the sympathetic, imaginative, and understanding direction of the commanding officer.

By V-J Day, it had become clear that paraplegics then in Army hospitals were to become the responsibility of the VA. Numerous conferences were held, participated in by the neurosurgical consultants, representatives of the Hospital Division and other divisions of the Office of the Surgeon General, and representatives of the VA.

At a conference of surgeons of the service commands on 27-29 September 1945, which was also attended by Maj. Gen. Paul R. Hawley, USA (ret.), newly appointed medical director of the VA, it was agreed that an effort would be made to concentrate all paraplegic patients into five Army hospitals and that the VA would take over these hospitals, thus insuring that there would be no break in the operation of the program.

The hospitals selected (Birmingham General Hospital, Van Nuys, Calif., Vaughan General Hospital, Hines, Ill., Cushing General Hospital, Framingham, Mass., McGuire General Hospital, Richmond, Va., and Kennedy General Hospital, Memphis, Tenn.) were all near large cities in various sections of the country, which would guarantee a continuance of the same high type of medical care and the same industrial and educational facilities which the paraplegic program had previously offered. The plan was that, as the hospitals in which they were then being cared for closed, the patients would be placed in the hospitals nearest their homes. All of the details of this planning appeared in Circular No. 440, Headquarters, Army Service Forces, 10 December 1945, which also contained a very detailed account of the purposes and techniques of the paraplegic program.

Survey of Paraplegic Patients

On 10 December 1945, the Office of the Adjutant General, Headquarters, Army Service Forces, issued instructions to the 19 general hospitals in the Zone of Interior in which paraplegic patients were then concentrated for a survey and comprehensive evaluation of these patients.² A detailed questionnaire was attached, to be filled in for each patient hospitalized as of 15 December 1945. The survey was carried out by the Surgical and Neuro-psychiatric Consultants Divisions, the Medical Statistics Division, and the Resources Analysis Division, Office of the Surgeon General.

The reasons stated for the survey were as follows:

1. The cessation of hostilities presaged a reduction and consolidation in the Army hospitalization system.

² Memorandum, Maj. Gen. Edward F. Witsell, Acting The Adjutant General, to commanding officers of general hospitals designated as neurosurgical centers, 10 Dec. 1945, subject: Survey of Paraplegia Patients.

2. An effective demobilization program had to take into consideration the requirements not only of the Army but also of the VA.

3. The exceptional success of the Army paraplegic program made it essential to continue it with minimum disturbance, although there was full recognition that the care of chronically ill patients was a responsibility of the VA.

4. In spite of the great success of the Army in caring for paraplegic patients, it was recognized that the long-term program could be further improved if additional information could be obtained concerning the present and prospective status of those who were still hospitalized.

Data secured.—Questionnaires were returned from 17 of the 19 paraplegic centers to which they were sent. DeWitt General Hospital, Auburn, Calif., and McCaw General Hospital, which were on the point of closing, did not participate in the survey. As of 15 December 1945, the date set for the study, there were approximately 1,500 paraplegics in Army hospitals. The smallest number of patients (5) were in Letterman General Hospital, San Francisco, Calif., and the largest number (139) in Kennedy General Hospital. There were more than 100 paraplegics in each of six other hospitals.

On 5 February 1946, a summarized report of the survey³ produced the following information and predictions:

As of 15 December 1945, 63 paraplegics had reached maximum improvement. Four of these would have to continue to receive institutional care, but 41 could be discharged to their own care and 18 to their homes if they could be cared for in them.

Exclusive of these 63 patients and 27 others for whom classification was not possible, 1,389 had not yet reached maximum improvement (table 1). Of this number, it was expected that 739 (more than 50 percent), would have reached maximum improvement by 30 June 1946 and 512 others by the end of the year. This left 138 patients (10 percent), who would not reach maximum improvement until after 31 December 1946.

Of the 1,389 paraplegics still to receive maximum improvement, 440 (about 30 percent), could be discharged to their own care, and 949 would require continued care indefinitely. About two-thirds of this group could receive such care in their homes if it could be provided; 348 would always require hospitalization.

On the assumption that the VA could accept all the patients transferred to it, there would remain, as of 1 July 1946, 650 paraplegics in Army hospitals. If the VA could not accept any patients, there would remain under Army care 715 patients if only those requiring institutional care were considered and almost 1,000 if those who required continued care indefinitely were taken into account.

At the time of the survey, 55 percent of the patients were classified as completely paralyzed. Medical officers were uncertain about the degree

³ Memorandum for Maj. Gen. Raymond W. Bliss from Eli Ginzberg, Director, Resources Analysis Division, Office of the Surgeon General, 5 Feb. 1946, subject: Paraplegic Patients.

TABLE 1.—*Report on status and probable disposition of paraplegia patients remaining as of 15 December 1945*

Status	Total	Discharge to own care	Will require continued care indefinitely		
			Total	Can be discharged to home	Will remain for institutional care
Patients who have achieved maximum improvement ¹	² 90	41	22	18	4
Patients who require further surgery or therapy.....	1, 389	440	949	601	348
Total.....	² 1, 479	481	971	619	352
Estimated time of maximum improvement:					
Prior to 31 Dec. 1945.....	35	5	30	0	30
1 Jan. 1946-31 Mar. 1946.....	231	133	98	41	57
1 Apr. 1946-30 June 1946.....	473	191	282	208	74
1 July 1946-30 Sept. 1946.....	356	48	308	230	78
1 Oct. 1946-31 Dec. 1946.....	156	43	113	66	47
After 31 Dec. 1946.....	138	20	118	56	62

¹ As defined in sec. II, Army Service Forces Circular No. 25, 22 Jan. 1945.

² Includes 27 patients not classified.

of ambulation likely to be achieved by the total group but ventured the opinion that about 4 of every 10 men would be permanently nonambulatory. They were willing to estimate that 71 percent of the entire group would have full use of their remaining extremities and that about 16 percent would have partial use of them.

It was estimated that approximately a quarter of the patients would have a work tolerance of 6 hours daily or less, that an additional 25 percent could work 6 to 8 hours, that about a third could work more than 8 hours but less than 12 hours, and that about a sixth would have work tolerances ranging to 13 or more hours per day. On the other hand, only 38 percent of the completely paralyzed patients would have a work tolerance in excess of 8 hours, compared to 63 percent of the incompletely paralyzed group.

Of the 1,399 patients for whom detailed questionnaires were returned, it was estimated that 472 could probably be discharged to their own care, 612 to their homes if care could be provided in them, and 293 to institutions. In 22 cases, no prognosis was possible.

Apparently medical officers took into consideration the ability of the family to care for the patient when predicting the final disposition of these men, although it was not the sole consideration. It was recommended that 90 patients whose families could not care for them should be discharged to home care or their own care, the disposition probably being predicated on the

professional conviction that, from the emotional standpoint, these patients would do better at home. Smaller percentages of the euphoric and depressed groups would be discharged to their own care.

A higher percentage of less well educated patients would probably be institutionalized. This fact, it was thought, might indicate a greater degree of adaptability on the part of those with more education or merely the superior economic status of the family, which was, of course, correlated with the amount of schooling the patients had received. Only a small percentage of students were likely to be hospitalized, while the farmer and clerk groups would have a higher than average percentage in this category.

Fifty-seven percent of the families stated that they could care for the patients; fourteen percent could not. In the remaining cases, this possibility had either not been investigated or was not specified. Fourteen percent of the patients had had no visits from their families during their hospitalization and had not visited them; 18 percent had less than one visit per month, 23 percent one or two visits, and 27 percent four visits or more. In 14 percent, the number of visits was not specified, and in 2 percent there was no information on this point. In 2 percent of the cases, the patients had gone home on furlough but had had no visits from their families.

There was no correlation between the ability of the family to care for the patient and the number of visits paid him per month; it was thought reasonable to expect more frequent visits on the part of the wealthier families.

Later Preparations for Transfer of Patients—1946

Plans for necessary alterations of the five proposed paraplegic centers to be transferred to the VA were drawn up by the Hospital Construction Branch, Office of the Surgeon General. The necessary physical changes included air conditioning, covered passages between buildings, numerous ramped exits, and other special construction required for the care of paraplegics with their peculiar needs. These plans were reviewed and approved by representatives of the VA.

The problem of personnel loomed large from the first. In January 1946, The Surgeon General had pointed out to General Hawley that it was imperative that the paraplegic program continue without interruption and that the transfer in status from Army to VA control be accomplished with the least possible difficulty. He suggested that representatives from the VA visit the hospitals to be transferred, with the idea of studying the treatment programs and recruiting necessary civilian personnel. He also suggested that it would be highly desirable that the transfer be accomplished gradually, so that, as the Army patient load declined, the VA might take over certain wards and buildings progressively, building up its staff as the transfers continued and eventually assuming operation of the entire hospital.

As the result of this suggestion, The Adjutant General, in February 1946, authorized the placing of VA personnel in Army hospitals which were

closing and also authorized the gradual transfer of portions of the hospital as The Surgeon General had directed. Arrangements were made for feeding of VA patients by Army messes during the phasing-out periods.

In March 1946, after it became evident that the civilian personnel employed by the VA did not fully understand the nature and techniques of the paraplegic program, a number of officers and enlisted men from the Sixth Service Command were detailed to the paraplegic center at Vaughan General Hospital to assist VA personnel until civilians could take over the program entirely. Similar arrangements were made in the Third Service Command at McGuire General Hospital. Close contact was maintained by the VA with the Personnel Division, Office of the Surgeon General, and physiotherapists and other qualified personnel were employed by the VA hospitals as the Army hospitals closed down.

In February 1946, representatives of the Office of the Surgeon General attended a meeting at the VA at which there was a briefing of the officers of the VA scheduled to go into the hospitals this organization was taking over.

Final Transfer of Program

The VA assumed control of Vaughan, Birmingham, and McGuire General Hospitals 31 March 1946 and of Kennedy General Hospital 30 June 1946. Cushing General Hospital passed into VA control 30 September 1946. By the time Army control of these hospitals ended, almost all of the approximately 1,500 patients in 19 Army hospitals in December 1945 had been brought together into these 5 hospitals.

At the end of December 1946, there were still 53 paraplegics in the Army hospital system; 28 of these were at Percy Jones General Hospital, Battle Creek, Mich., and were to remain there until necessary plastic surgery had been completed. There were 4 each at Brooke General Hospital, Fort Sam Houston, Tex., and McCornack General Hospital, Pasadena, Calif., 2 each at Oliver General Hospital, Augusta, Ga., and Pratt General Hospital, Coral Gables, Fla., 1 at the Army and Navy General Hospital, Hot Springs, Ark., 1 at Fitzsimons General Hospital, Denver, Colo., and 11 at Walter Reed General Hospital, Washington, D.C. These few patients were still receiving necessary professional care before their final disposition. The transfer of all the others from the Army hospital system to the VA system had been effected expeditiously and without interruption of the planned paraplegic program.

The neurosurgical procedures required by the patients still in Army hospitals in December 1945 included 33 operations for pain and 61 for muscle spasm. Of 432 patients who still had decubitus ulcers, 179 would need surgery. Further treatment to achieve bladder control compatible with the existing cord lesion was required in 298 patients, and 52 required treatment for infection, stone, and other urinary tract complications.

CHAPTER III

The Mediterranean (Formerly North African) Theater of Operations

*Eldridge H. Campbell, Jr., M.D.*¹

INCIDENCE

Detailed information concerning deaths from battle wounds which occurred in Fifth U.S. Army hospitals in Italy during 1944 and 1945 is available in the 1,450 fatalities analyzed in the massive study carried out by Maj. (later Col.) Howard E. Snyder, MC, and Capt. (later Maj.) James W. Culbertson, MC.² This analysis showed that injuries of the spine accounted for 0.94 percent of all battle casualties treated in these hospitals during this period of time and for 1.9 percent of the 1,450 fatalities. This is in contrast to all wounds of the chest and abdomen, which together accounted for 13.6 percent of all Fifth U.S. Army battle-casualty admissions and for 52.2 percent of the 1,450 fatalities.

In another survey, Capt. Wolfgang W. Klemperer, MC, found that, in a series of 115 missile injuries of the spinal cord, injuries of the chest, abdomen, or both were present in 19 of 82 injuries of the cervicothoracic cord and in 11 of 33 injuries of the lumbosacral cord.³ Thoracic injuries (18 cases) predominated in the injuries of the cervicothoracic cord and abdominal or thoracoabdominal (10 cases) in the injuries of the lumbosacral cord.

The bullet was retained in the spinal canal (figs. 3 and 4) in 4 of a series of 68 cord injuries studied by Capt. William B. Weary, MC, and in 59 of a (second) series of 201 cases studied by Captain Klemperer. The apparent discrepancy between the two series is easily explained; most of Captain Klemperer's cases were observed in forward hospitals before operation and most of Captain Weary's in rear hospitals after initial surgery. Paralysis was complete in 27 of the 59 cases in which the missile was re-

¹ A consultant in neurosurgery was never formally appointed in the Mediterranean theater. When the need arose, Dr. Campbell, then a lieutenant colonel in the Medical Corps, represented the consultant in surgery to the Theater Surgeon. Gaps in this chapter are due to this fact; they could not be overcome because of Dr. Campbell's death while the history was in preparation.

² Snyder, Howard E., and Culbertson, James W.: Study of Fifth Army Hospital Battle Casualty Deaths. An Analysis of Case Reports From Field and Evacuation Hospitals on 1,450 Fatally Wounded American Soldiers. A Preliminary Report, in three volumes. Gardone Riviera, Italy, September 1945. [Official record.]

³ Klemperer, W. W.: Statistical Report on Spinal Cord Injuries. M. Bull. North African Theat. Op. 1: 12-15, March 1944.

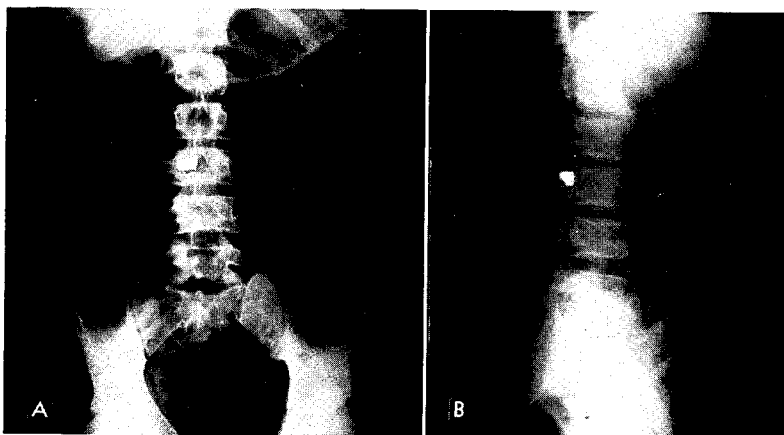

FIGURE 3.—Roentgenograms showing shell fragment wound of spinal canal with paraplegia. A. Anteroposterior view showing irregular shell fragment at level of third lumbar vertebra. B. Lateral view showing shell fragment within dural canal.

tained in Captain Klemperer's cases, in comparison with complete paralysis in 65 of the 104 cases in which the missile was definitely stated to have come to rest outside of the canal. Complete paralysis was also more frequent in the 94 thoracic and 47 cervical injuries than in injuries of other zones. There were only 17 instances of complete paralysis in the 55 lumbar injuries and none in the 5 sacral injuries. Variations in relative size, fixation, and vulnerability of tissues to trauma probably account for these differences.

SURGICAL POLICIES

In the Tunisian campaign of 1942-43, the policy of management of injuries of the spine was one of great conservatism. This attitude, which was derived from previous civilian experience with similar injuries, continued throughout the Mediterranean campaign as far as fracture-dislocations of the closed type were concerned. It was, however, considerably liberalized for missile injuries. Anatomic disruption of the cord proved extremely difficult to predict solely on the basis of neurologic or roentgenologic examination. While the great majority of patients with immediate and complete paralyzes could be expected to recover little if any function after operation, there were numerous exceptions. For this reason, if the patient's general condition were satisfactory and if other high-priority casualties with better chances of recovery were not thereby denied operation, debridement and laminectomy were performed even in apparently hopeless cases.

In general, there were two reasons for attempting decompression of the cord: (1) The necessity for debridement of the wound, which was just as valid in this region as anywhere else in the body, and (2) an attempt to

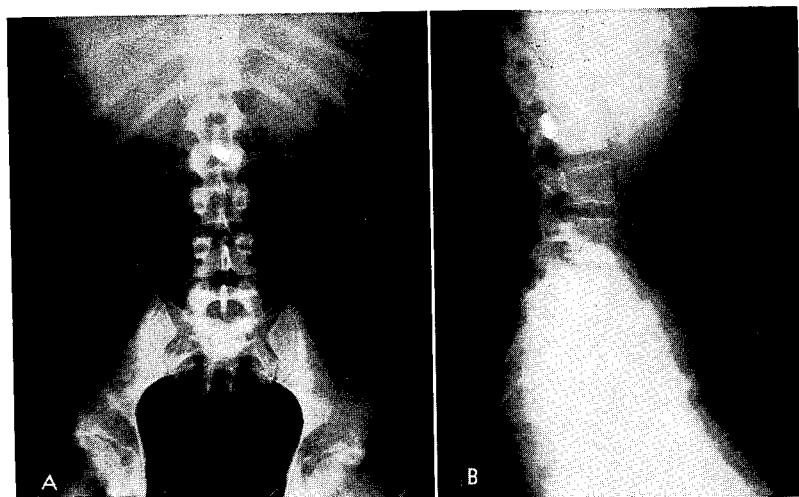

FIGURE 4.—Roentgenograms showing bullet wound of spinal canal with paraplegia. A. Anteroposterior projection showing rifle bullet at level of second lumbar vertebra. B. Lateral view showing rifle bullet within dural canal.

relieve pressure upon the cord. Debridement was regarded as particularly essential if the wound of entrance or of exit was in the back. The danger of infection was not so great if the missile had penetrated the spinal canal from in front, though effective reparative surgery was then much more difficult. Failure to debride or to close wounds of the lumbar and sacral areas was always likely to lead to complications.

Persistent cardiorespiratory imbalance was regarded as a clear contraindication to laminectomy. Injuries of the chest and abdomen and major injuries of the extremities usually demanded priority of surgery because they presented a risk to life which the wound of the spine, for the moment, did not. Thoracic injuries carried a particular hazard when the respiratory muscles were weakened or paralyzed, and in at least one instance death is known to have occurred from tension pneumothorax because all the attention was concentrated on the spinal cord injury.

The best results were achieved when debridement and laminectomy could be performed within 24 hours of wounding. When concomitant wounds were present, a double major operation was usually more than a recently wounded casualty could tolerate, and debridement and exploration of the spinal wound therefore had to be deferred until some recovery from the first procedure had taken place. Improvement was the rule if debridement was done for a missile wound of the spinal column which had caused only partial paralysis, particularly if there was pressure on the cord or if a foreign body had entered the canal. Even partial recovery was most unusual if paralysis had been immediate and complete.

DECUBITUS ULCERS

The prevention and treatment of decubitus ulcers in patients with spinal cord injuries was a serious nursing problem. A paraplegic patient left without attention for only a few hours inevitably developed pressure sores. Because of delays in evacuation, many paraplegics arrived at general hospitals with pressure sores already present. Once they had been hospitalized, the development of decubitus ulcers was the exception, though the record was achieved only by unremitting care. An instance of what such good nursing can accomplish is the record of the neurosurgical center at the 33d General Hospital, in which only one bedsore developed after admission in approximately 200 paraplegic patients.

MANAGEMENT OF THE CORD BLADDER

Suprapubic cystostomy was found to be the most satisfactory method of managing the cord bladder when the care of the paraplegic patient had to be carried out by any but the most experienced personnel. It was also the most practical method in military hospitals during busy periods.

Tidal drainage was not used during the North African campaign because materials for it were not available in adequate quantities. Later, it was found that this method was not practical under military circumstances, partly because of the risk of leakage of air into the system and partly because the frequent turning of the patients, which was necessary to prevent bedsores, entailed constant readjustment of the apparatus and was prohibitively time consuming.

Urologic complications were fortunately uncommon. Sulfadiazine and penicillin were not employed prophylactically, although many patients received sulfadiazine for other reasons. The deliberate use of these agents in urinary tract complications was reserved for the treatment of acute infections.

HOSPITAL MANAGEMENT

Good nursing care of paraplegic patients proved, as always, to be requisite for optimal convalescence. All departments of the hospital cooperated in the treatment of paraplegic patients. The genitourinary division was responsible for the care of suprapubic cystostomies, indwelling catheters, and bladder irrigations. The orthopedic division made the plaster shells for immobilization when they were indicated and prepared the splints used as a preventive or corrective measure in footdrop. Physiotherapists carried out active and passive exercise to maintain joint function and assisted in light (infrared) treatment of decubitus ulcers.

Psychotherapy was an important phase of treatment in many cases and was indirectly aided by the services of American Red Cross aides, who provided occupational therapy, reading matter, and recreation. The general

attitude of all who came into contact with the patients was expected to be one of cheerfulness and optimism.

It was the practice, as far as possible, to make few changes in nurses and aidmen assigned to paraplegic wards. More nursing hours were required for patients with these injuries than for any other patients in the hospital. Because of the general use of catheters, however, the amount of linen used was actually less than on the acute surgical wards, on which patients were frequently incontinent of both urine and feces.

EVACUATION

Evacuation from the point of wounding to the forward hospital was found to entail certain hazards in missile wounds of the spinal column, though these were possibly not as great as in closed injuries, in which loss of bony stability was sometimes considerable. Immobilization of an injured part, which was often necessary, had to be carried out with the greatest care. If local pressure and ischemia were permitted to last more than a very few hours, the basis of the development of bedsores could be laid quite as well in this period as in any later period. Since plaster and splints were impractical at the division level, paraplegic patients were usually transported on well-padded litters, braced by folded blankets and straps. Attempts at extension, even by experienced surgeons, were not recommended until the forward hospital was reached.

Evacuation from the base hospital to the Zone of Interior was also fraught with hazard. Nursing care was frequently inadequate during long journeys, and unpredictable delays might impose a great burden on the skin or the bladder.

If paralysis was complete, and particularly if the cord injury was high, patients seemed to travel more comfortably in well-made plaster halfshells. They felt more secure, and, if the shells were properly molded and adequately padded, pressure was evenly distributed and pressure sores were unlikely to develop. Plaster body casts were not advisable, if only because they prevented inspection and care of the skin. If a plaster shell was used, it was neither necessary nor desirable to keep the upper half in situ.

It was found to be a wise plan to instruct each patient, before departure, concerning his own needs and particularly concerning the intervals at which he should be turned, so that, if the precaution was omitted by the attendants, he could make the necessity known.

CHAPTER IV

The European Theater of Operations

R. Glen Spurling, M.D.

SURGICAL POLICIES

Injuries to the spinal cord accounted for a considerably greater number of neurosurgical casualties¹ in the European theater than had been anticipated, some 12 percent in all. About half of the injuries were gunshot wounds. In the other cases, spinal cord damage resulted from fractures or fracture-dislocations of the vertebrae, some of which were caused by traffic accidents. These injuries required a much greater proportion of the neurosurgeon's time and effort than the percentage might suggest. In about half of all combat-incurred injuries, severe associated injuries, particularly wounds of the chest and abdomen, made the care of these patients doubly difficult.

Neurosurgeons, at least early in the fighting in the European theater, were not in agreement about the value of surgical exploration of spinal cord injuries. The dictum that very few injuries of the spine in which the cord was involved would be improved by operation had been carried over from civilian practice into military practice, and for a time it seriously handicapped military neurosurgeons. As a matter of fact, the attempt to correlate the two types of injuries was as fallacious as it was misleading. The "broken back" of civilian practice is usually a lesion which affects the vertebral body primarily (figs. 5 and 6). The major lesion in a gunshot wound of the spine was likely to be in the vertebral arches (figs. 7 and 8).

Paraplegia proved the most distressing of all military neurosurgical conditions and the most difficult to benefit. It was fully realized that in only a very small proportion of these cases could surgery improve the patient's lot, but it was also realized, with equal clarity, that in an occasional case, particularly the type of case in which the bony injury was limited to the vertebral arches, debridement of the spinal canal might occasionally result in dramatic improvement.

The policy was therefore formulated before D-day in the European theater and was disseminated to all neurosurgeons that, whenever there was reasonable doubt concerning the complete destruction of the spinal cord, the patient should have the benefit of prompt exploration, particularly if

¹ Neurosurgical conditions were defined early in World War II as surgical lesions of the brain, spinal cord, peripheral nerves, and sympathetic nervous system.

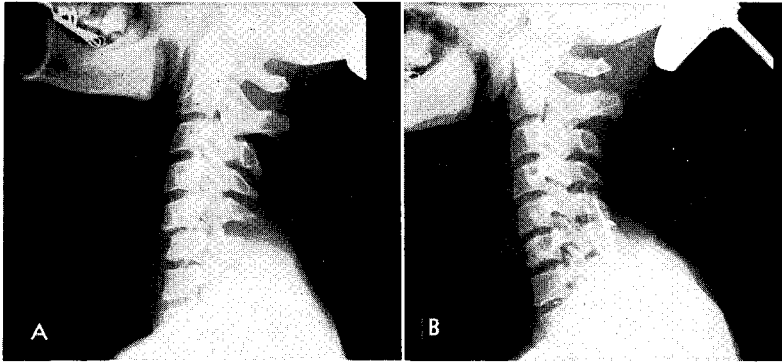

FIGURE 5.—Fracture-dislocation of fifth cervical vertebra on sixth in accident involving military vehicle. A. Prereduction roentgenogram. B. Roentgenogram after reduction and fusion.

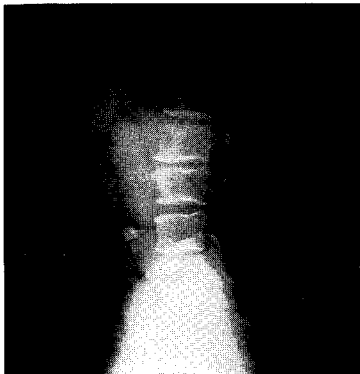

FIGURE 6.—Lateral roentgenogram showing mild crush fracture of third lumbar vertebra with paraparesis. The injury was sustained during a jump from a military vehicle under enemy fire. This illustration, like figure 5, is typical of the so-called civilian type vertebral injury seen in military personnel.

there was evidence of subarachnoid block by the Queckenstedt test. Operation was to be done under local analgesia, on the litter on which the patient had been transported, unless circumstances made it imperative to move him. The dura was not to be opened in the absence of definite indications.

Reports of 1,260 battle-incurred wounds of the spinal cord (table 2) made to the Senior Consultant in Neurosurgery, Office of the Chief Surgeon, by 25 neurosurgeons in the European theater showed that operation was performed in 479 (38 percent). Most of these operations were performed at the level of the evacuation hospital on the Continent or in general hospitals in the United Kingdom. Whenever possible, the operation was done in a general hospital.

In about 15 percent of all patients operated on, according to these reports, the plan of management just outlined resulted in striking improvement within 48 hours after operation. Other benefits were also accomplished. Spinal fluid leaks were eliminated by closure of defects in the dura. Root pain was eliminated by the removal of bony chips and foreign bodies about the posterior nerve roots. Another advantage was that the prognosis in the

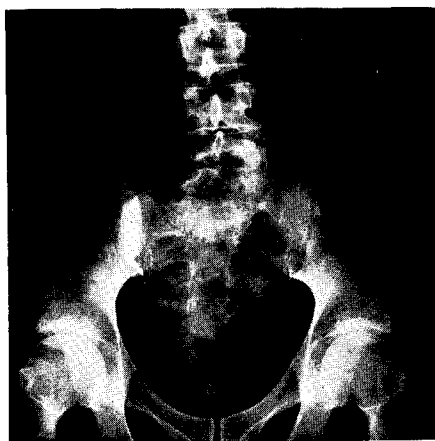

FIGURE 7.—Roentgenogram showing large shell fragment wound of cauda equina, with disruption of lateral components of fourth and fifth lumbar vertebrae. This injury was associated with a major abdominal injury.

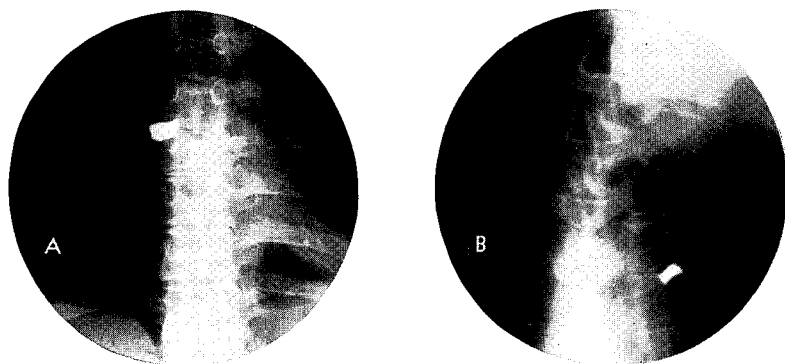

FIGURE 8.—Roentgenograms showing traversing shell fragment wound of spinal canal. A. Anterior projection. B. Lateral view of same wound showing fragmentation of vertebral body.

individual case could be made with greater certainty after inspection of the anatomic damage to the spinal cord.

Manual of Therapy.—Instructions concerning fractures of the spine with neurologic involvement, as given in the *Manual of Therapy*,² which was prepared in the European theater before D-day, were chiefly concerned with diagnosis of the injury and with the prevention of further trauma. High priority of transportation to evacuation or general hospitals was indicated.

² *Manual of Therapy*, Office of the Chief Surgeon, European Theater of Operations, U.S. Army, 5 May 1944. Appropriate sections published in *Medical Department, United States Army Surgery in World War II, Neurosurgery, Volume 1*. Washington: U.S. Government Printing Office, 1958, appendix B, p. 403.

TABLE 2.—Percentage distribution of 1,260 battle-incurred injuries of spinal cord observed in United Kingdom hospitals, from D-day to V-E Day

Period	Injuries			Physiologic loss		Operation	All infections		Case fatality rate	
	Number	Cervical	Thoracic	Lumbar	Complete		Incomplete	Epidural abscess		Meningitis
			Percent	Percent	Percent	Percent	Percent	Percent	Percent	Percent
D-day-31 July 1944.....	247	15.0	53.0	32.0	63.0	37.0	140.0	8.0	0.8	---
1 Aug. 1944-31 Oct. 1944.....	457	17.0	48.0	35.0	62.0	38.0	243.0	9.0	.3	5.0
1 Nov. 1944-31 Jan. 1945.....	313	18.0	47.0	40.0	55.0	45.0	229.0	2.2	2.5	3.8
1 Feb. 1945-V-E Day.....	243	16.0	43.0	41.0	45.0	55.0	238.0	2.0	2.1	5.0
Total.....	1,260	15.5	47.7	36.8	57.1	42.9	38.0	5.8	1.3	4.6

¹ Marked postoperative improvement occurred in 12.0 percent of the cases.

² Marked postoperative improvement occurred in 8.0 percent of the cases.

³ Marked postoperative improvement occurred in 13.0 percent of the cases.

⁴ Marked postoperative improvement occurred in 16.0 percent of the cases.

⁵ Based on 1,013 cases, from 1 Aug. 1944, to V-E Day.

When the manual was revised at the close of the active campaign in Europe, it was found that the only major changes necessary in the neuro-surgical section concerned the transportation and care of paraplegics. Their entire management had become considerably more aggressive.

TRANSPORTATION

Originally, a choice was permitted in the method of transporting patients with spinal injuries in the thoracic and lumbar regions, either the recumbent or the prone position being used. Experience promptly showed that the prone or semiprone position was far superior to the supine position. It eliminated the necessity for a cast. The patient traveled more comfortably. Finally, there was less chance of the development of decubitus ulcers. The prone position was therefore used routinely during the closing months of the fighting in Europe unless an associated thoracic or abdominal wound contraindicated it.

When the needs of paraplegic patients were realized, air mattresses were authorized for immediate delivery to all general hospitals in which such care was given, and their addition to the permanent table of basic allowances for all 1,000-bed hospitals was also recommended. Approval was obtained from the Theater Chief Surgeon for placing air mattresses, suitably sized to fit army field cots, field ambulances, hospital trains, and air ambulances in all field and evacuation hospitals. Recommendations concerning these mattresses were forwarded to Lt. Col. (later Col.) Augustus Crisler, MC, Chief Consultant in Surgery, First U.S. Army, who was enthusiastic in his support of the project. High priority for the procurement of these mattresses in suitable numbers was obtained from Col. (later Maj. Gen.) S. B. Hays, MC, Chief, Medical Supply, Office of the Chief Surgeon, Headquarters, European theater, and they proved extremely useful.

It was recommended that all hospitals designated for the care of neuro-surgical patients order from the nearest supply depot an operating table pad (item 7162800) for every patient with transverse myelitis and that an adequate supply of these pads be kept on hand to meet these calls. These pads fitted the army stretcher and facilitated the evacuation of paraplegic patients to the Zone of Interior after they were made available.

Patients were usually transported with indwelling catheters, with clamps. The attendants who accompanied them were instructed to open the clamps and drain off the urine every 2 hours.

DECUBITUS ULCERS

Decubitus ulcers occurred in some paraplegics in spite of every effort to prevent them. Preventive measures included strict local cleanliness, turning of the patients at regular intervals, maintenance of a high-protein intake, and systemic chemotherapy and antibiotic therapy. When ulcers developed,

these same measures were useful. The experience with applications of plasma locally was not encouraging. Every effort was made to get these patients into condition for evacuation, so that skin grafting could be accomplished in Zone of Interior hospitals. Most patients were ready for evacuation within 90 days after wounding.

THE CORD BLADDER

It was originally believed that the cord bladder could be handled successfully by tidal drainage through an indwelling urethral catheter for a period of 4 or 5 weeks. Experience proved that this method, which required a great deal of care and attention, was not suitable for use in wartime on busy wards filled with paraplegic patients. During the latter half of the European campaign, therefore, high suprapubic cystostomy was resorted to at once in all patients with complete physiologic loss of cord function. It was constantly stressed, however, that even though tidal drainage had proved impractical in the immediate postwounding period, this was because of the circumstances and not because of any inherent defect in the method. Tidal drainage was a very valuable and entirely practical method later, because it helped to maintain bladder capacity after the wound had contracted around the suprapubic tube.

In a series of 100 paraplegics observed at one Army hospital in the European theater between D-day and 30 November 1944, tidal drainage was used in 65 cases. On an average of 20 days, 31 patients had had a return of bladder function, 18 patients were still on drainage when the survey was made, and 16 had required suprapubic cystostomy because there had been no bladder recovery. Suprapubic cystostomy was done primarily in the remaining cases. In 6 of these 100 patients, the injury was cervical, in 45 thoracic, and in 49 lumbosacral. In 69 cases there were associated major injuries, including wounds of the chest in 30 cases, intra-abdominal wounds in 16 cases, and fractures in 23 cases. In spite of the difficulties of managing patients who were so seriously wounded, no gross urinary tract infections had occurred.

CHAPTER V

The Management of Acute Compound Battle-Incurred Injuries of the Spinal Cord

Donald D. Matson, M.D.

HISTORICAL NOTE

A great deal of information concerning the symptoms and signs of compound wounds of the spinal cord, as well as the pathologic processes in these injuries, was accumulated during World War I, particularly by British neurologists.¹ The interpretation of this material from the point of view of therapy was, however, scanty and inconclusive. As Tinsley² noted, the Medical Research Council of Great Britain, in its review of World War I spinal cord injuries, recommended laminectomy only for incomplete lesions with progressive signs of functional loss and stated that a physiologically complete transection of 48 hours' duration was a contraindication to surgery because of the hopeless prognosis. This review also claimed that the gravity of the initial injury was not increased by the presence of a foreign body or of indriven bone in the cord.

In reviewing experiences with injuries of the spinal cord in the U.S. Army in World War I, Cushing³ stated merely that most of these casualties were evacuated to base hospitals for therapy and that only those patients survived whose lesions were partial. When there was immediate complete loss of sensation and motor power, only debridement of the external wound was performed. Hanson⁴ noted that Cushing reported 32 cases of spinal cord injury with a case fatality rate of 71.8 percent; 24 of these patients were operated on, with a case fatality rate of 62.5 percent.

In World War II, compound wounds of the cord were among the most difficult and in many ways the most discouraging of all wounds to treat.

¹ (1) Holmes, G.: I. The Pathology of Acute Spinal Injuries. *Brit. M.J.* 2: 769-774, 27 Nov. 1915. II. The Clinical Symptoms of Gunshot Injuries of the Spine. *Brit. M.J.* 2: 815-821, 4 Dec. 1915. III. The Sensory Disturbances in Spinal Injuries. *Brit. M.J.* 2: 855-861, 11 Dec. 1915. (2) Discussion on Gunshot Wounds of the Spine. *Brit. M.J.* 1: 451-452, 25 Mar. 1916.

² Tinsley, M.: Compound Injuries of the Spinal Cord. *J. Neurosurg.* 3: 306-309, July 1946.

³ Cushing, Harvey: Organization and Activities of the Neurological Service, American Expeditionary Forces. *In* The Medical Department of the United States Army in the World War. Washington: Government Printing Office, 1927, vol. XI, pt. 1, pp. 749-758.

⁴ Hanson, Adolph M.: Management of Gunshot Wounds of the Head and Neck in Forward Hospitals, A.E.F. *In* The Medical Department of the United States Army in the World War. Washington: Government Printing Office, 1927, vol. XI, pt. 1, pp. 776-794.

On the other hand, the overall case fatality rate in patients reaching field and evacuation hospitals alive was reduced to around 15 percent, and the postoperative case fatality rate for early laminectomy was reduced to between 5 and 12 percent, according to Tinsley and others.⁵ One can only speculate how much preservation of function was accomplished by treatment during the acute phase of injury.

Many factors were responsible for this reduction in mortality. The most important of these were (1) the rapid evacuation of patients with spinal cord injuries to general hospitals in the rear, where adequate specialized equipment and neurosurgical personnel were available, (2) the presence in forward hospitals of trained surgeons capable of performing early laminectomy on nontransportable patients with serious injuries, (3) routine systemic chemotherapy and antibiotic therapy in the treatment of all compound wounds as well as the prophylactic use of these agents in the prevention of urinary and pulmonary complications, and (4) the general availability in the forward areas of large quantities of blood for replacement therapy.

Because of the widespread confusion which prevailed regarding therapy of spinal wounds in the acute stage, a historical account of their treatment in World War II is a difficult task. In this chapter, however, an attempt has been made to describe the pathologic processes of these injuries as seen in their early stages, the clinical problems which they presented, and the consensus with respect to early operative and supportive treatment. No attempt has been made to discuss final results.

CLASSIFICATION OF COMPOUND INJURIES OF THE SPINAL CORD

Injuries to the spinal cord produced by high-explosive missiles may be divided into three etiologic groups, as follows:

1. *Direct injuries due to missiles.*—This group includes wounds produced by the passage of bullets or shell fragments directly into, or through, the substance of the cord or the cauda equina. Division of structural continuity produced in this fashion was permanent, since no regeneration of nervous tissue within the central nervous system can occur. If only partial anatomic transection was brought about by such a direct injury, the adjacent nervous elements might be spared both anatomically and physiologically, or they might be spared anatomically and interrupted physiologically, either temporarily or permanently. The damage produced directly to the cord occurred in two ways: (1) By destruction at the moment the metallic foreign

⁵ (1) Haynes, W. G.: Acute War Wounds of the Spinal Cord. Analysis of 184 Cases. *Am. J. Surg.* 72: 424-433, September 1946. (2) Matson, D. D.: Treatment of Compound Spine Injuries in Forward Army Hospitals. *J. Neurosurg.* 3: 114-119, March 1946. (3) Pool, J. L.: Gunshot Wounds of the Spine; Observations from an Evacuation Hospital. *Surg. Gynec. & Obst.* 81: 617-622, December 1945.

body struck, or (2) by subsequent compression of nervous tissue caused by the presence of the foreign body in the spinal canal.

2. *Indirect injuries produced by bone.*—In this group are included wounds in which a missile fractured the vertebra and caused depressed or comminuted fragments of bone to lacerate the cord or protrude into the spinal canal and compress the cord. In this group, as in the first group, the damage might be produced either at the moment of injury or by subsequent pressure or movement of the bony fragments within the spinal canal.

3. *Indirect injuries due to concussion.*—This group includes wounds in which a loss of neurologic function occurred after passage of a missile in the vicinity of the spinal column but not through the canal itself. Presumably, the impairment of function resulted from disturbance of neuronal cytoplasm due to transmission of a pressure wave from the path of the missile.

From a mechanical point of view, direct compound spinal injuries can be divided into three common varieties (fig. 9), as follows:

1. Ricocheting wounds, in which a missile struck the vertebral body or neural arch, fractured it, and drove bone fragments into the canal but bounced off into the soft tissues at an angle to the direction of entry. These wounds had the most favorable prognosis of all.

2. Perforating wounds, in which a missile passed completely through the spinal canal or a portion of it. These wounds almost invariably carried a poor prognosis.

3. Penetrating wounds, in which a missile lodged in the spinal canal itself or in the bony vertebra and protruded into the canal. These wounds sometimes had a favorable prognosis after early operation.

As noted by Scarff,⁶ the loss of neurologic function immediately after direct compound spinal cord injury may be due, from a pathologic point of view, to any one of the following factors or to a combination of them: (1) Edema of the cord, (2) hemorrhage into or about the cord, (3) compression of the cord by bone fragments or foreign bodies, and (4) anatomic section of the cord.

Unfortunately, in the acute phase of injury, the surgeon's efforts toward restoration of function could be directed effectively toward only one of these etiologic factors; namely, localized, extrinsic compression of the cord. There is no need to discuss anatomic section of the cord except to reiterate that this is a hopeless injury, since neuronal elements within the central nervous system never regenerate. Edema of the cord was extremely common and was often severe, but surgical treatment was not effective in it either unless persistent extrinsic compression was a factor in producing it. There has never been reliable evidence that the function of a swollen, contused cord could be improved by operative removal of normal laminae or incision of intact dura.

⁶ Scarff, J. E.: The Surgical Treatment of Injuries of the Brain, Spinal Cord, and Peripheral Nerves. *Surg. Gynec. & Obst.* 81: 405-424, October 1945.

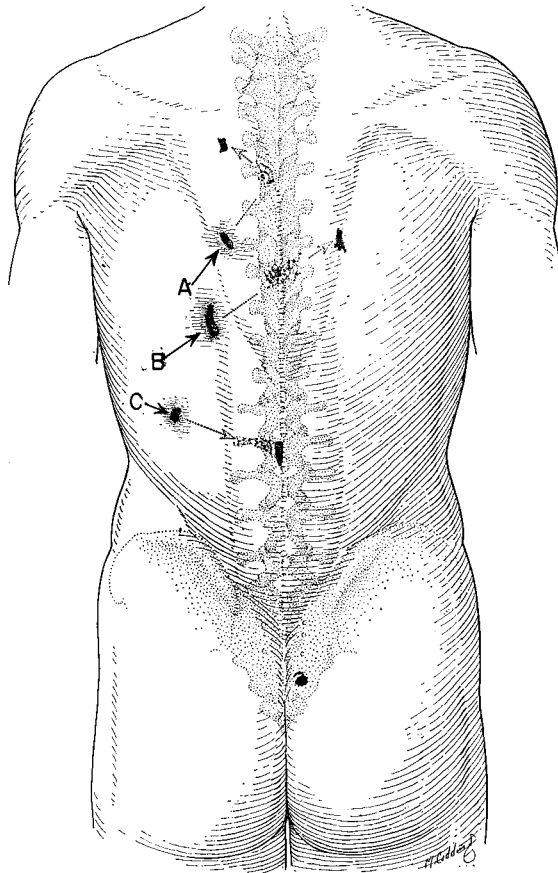

FIGURE 9.—Common varieties of compound spinal wounds due to high-explosive missiles. A. Ricocheting wound. The metallic foreign body has struck the spine and been deflected at an angle on the same side as the wound of entry. B. Through-and-through wound. The metallic foreign body has passed completely through the spinal canal to lie in the soft tissues on the side opposite the wound of entry. C. Penetrating wound. The metallic foreign body lies impacted in the spine or free within the spinal canal.

As to hemorrhage, it was extremely uncommon to find extradural, subdural, or subarachnoid bleeding in any significant amount. Serious local compression of the cord by hematoma was not seen.⁷ As pointed out by Pilcher,⁸ there is adequate space both inside and outside the dura for longitudinal infiltration of extravasated blood. Intramedullary hemorrhage, on the other hand, undoubtedly contributed to cord destruction, but, like edema of the cord, it was not responsive to surgical treatment.

⁷ See footnote 5, p. 32.

⁸ Pilcher, C.: Injuries of the Spinal Cord and Cauda Equina. *South. Surgeon* 11: 755-764, November 1942.

It becomes apparent, therefore, that, except for the relief of compression due to indriven bone fragments and foreign bodies, the efforts of the neurosurgeon in the early treatment of injuries of the spinal cord were limited to (1) prophylaxis against infection, (2) relief of pain, and (3) the prevention of urinary, gastrointestinal, and skin complications.

FIRST AID TREATMENT

Almost without exception, patients with spinal cord injuries became helpless immediately. Also, with rare exceptions, the maximum extent of the paralysis occurred at the moment of injury. The casualty lay where he was injured until he could be moved by litter. External wounds were usually dressed on the field or at the first battalion aid or clearing station reached.

In the early months of the European campaign, it was customary to sprinkle sulfanilamide powder into all wounds before dressings were applied. Later, this practice was largely discontinued, and patients were given penicillin intramuscularly in doses of 20,000 to 40,000 units at the first medical installation reached. Efforts were then made to continue regular systemic antibiotic therapy without interruption throughout the preoperative and postoperative periods.

Care in moving patients with closed injuries of the spine, especially fracture-dislocations, was always extremely important because of the ease with which additional cord damage could be brought about by mismanagement. In penetrating injuries of the spine, particularly in the cervical region, this same danger was present, though perhaps not to the same degree.

Casualties with injuries of the lumbar spine traveled well either in the prone position or on their backs, with a pillow or folded blanket under the lumbar region. Those with thoracic injuries traveled satisfactorily in either the supine or prone position. Those with injuries of the cervical spine traveled satisfactorily only if lying on their backs with a small pillow or folded blanket underneath the shoulders, so as to raise them 2 to 3 inches and allow the head to fall back into slight extension.

In moving patients with cord injuries, flexion, extension, and torsion of the spine were avoided. Aidmen (preferably two or three) were instructed to lift or roll the patient like a log when placing him on a litter. Once he was on the litter, no further movement was permitted, except for treatment of shock, removal of clothing, necessary first aid dressings, catheterization, and physical examination, until he had reached a field or evacuation hospital or even, after transport by air or ambulance, to a general hospital. Thus he often reached the destination for definitive treatment on the same litter on which he was first placed immediately after wounding. No attempt was made to hyperextend a patient unless there was evidence of a compressed fracture of a vertebral body.

The early introduction of an indwelling urethral catheter was essential (p. 61). If the tactical situation did not permit evacuation to a forward hospital within a reasonable length of time (4 to 8 hours), catheterization was often carried out as a first aid procedure. When this precaution was neglected, distention of the bladder with overflow incontinence resulted.

Morphine sulfate, in doses of 16 to 32 mg. subcutaneously, was ordinarily administered for pain, which frequently, however, was not an outstanding feature of this type of injury.

Shock was often profound, especially when the spinal wounds were associated with penetrating wounds of the chest and abdomen, as well as in complete anatomic transection of the cord in the low cervical or high thoracic region. Wet clothing was removed and warmth applied. Transfusions of plasma were given on the field or in battalion aid, collecting, or clearing stations when it was necessary to support the patient for evacuation. On his arrival at a field or evacuation hospital, transfusions of whole blood or additional transfusions of plasma were given as indicated. Small doses of ephedrine sulfate at intervals were effective in combating hypotension.

NEUROLOGIC EXAMINATION

When a patient with a definite or suspected spinal cord injury arrived at a hospital equipped for definitive operative treatment, a brief but careful neurologic examination was carried out as soon as possible. This was done as part of the initial examination unless shock was present. In such cases, resuscitation took precedence over all other procedures. In addition to those patients whose obvious paraplegia made the diagnosis of cord injury immediately apparent, it soon became evident that, to rule out the possibility of spinal cord damage, every patient with a penetrating wound of the neck, shoulders, thorax, abdomen, and back must be checked briefly for sensation, voluntary motion of the extremities, and urinary retention. Otherwise, preoccupation with obvious penetrating wounds of the chest and abdomen might result in unfortunate neglect of an associated spinal injury.

Symptoms

Except for the occasional patient with cervical damage, patients with spinal cord injuries usually remained conscious and alert from the moment of wounding. They could often give an accurate account of how they were wounded and of any subjective changes observed from the time of injury to the time of examination. It was extremely important to question each patient carefully to obtain these details. Although there were no definite symptoms which differentiated complete anatomic from complete physiologic transection of the cord, clues could sometimes be picked up from the history which would definitely establish the incompleteness, or at least suggest a reasonable doubt of the completeness, of a cord transection.

If there was a history of abrupt and complete loss of motion and all forms of sensation ("dead all over") from the instant of injury, with no subsequent subjective change, then the presence of complete physiologic transection of the cord, though not necessarily of anatomic transection, was likely. The outlook under these circumstances was generally poor. If, on the other hand, the patient stated that, after being hit, he was able to walk or run for a short distance before he collapsed, or if he at any time had experienced pain, sensations of warmth or cold, or paresthesias of any kind in the lower extremities, or if he had been able to pass any urine spontaneously, then the lesion was considered an incomplete one until proved otherwise, and the outlook was generally much more favorable.

Signs

Elaborate equipment was not necessary for satisfactory neurologic examination. In most instances, with a pin and a percussion hammer, an adequate clinical appraisal could be made in a very few moments. Such an examination, together with examination of the external wounds and of roentgenograms, gave sufficient information to localize the lesion and indicate proper therapy. The early clinical picture often gave an impression of a more severe injury than actually existed. The reverse was never true.

In complete transection of the spinal cord, whether anatomic or physiologic, there was absolute loss of sensation below a well-demarcated level which corresponded to the known anatomic segmental configuration. Light touch, pain, temperature sensations, position sense, vibration, and deep pressure were all absent below the level of the lesion. It was important to test all of these, particularly pain and deep pressure. Often there was a band of hyperesthesia extending one to two dermatomes above the anesthetic level. The upper level of anesthesia might move a segment or two up or down, depending upon the extent of associated edema of the cord, but in complete lesions, anesthesia always remained uniform throughout the anesthetic area. It was never spotty, and it never exhibited remissions and exacerbations. If there was ever reliable appreciation of any type of sensation, even though transient, at some point below the level of injury, then the lesion was considered partial. According to Haynes, a clinical level of anesthesia and paralysis two to three segments higher than the level of bony injury shown in roentgenograms usually indicated a complete transection.

In total transections, there was immediate complete flaccid paralysis of all muscles innervated from cord levels below the site of the lesion. The maintenance of any muscle tone or voluntary movement therefore indicated an incomplete transection.

In total transections, immediate complete areflexia was observed below the level of injury in almost every instance. Certain exceptions to this generally accepted finding were noted by Matson, Pool, and others. Occasionally,

a bilateral atypical plantar response was obtained in complete lesions, in the form of a delayed, weak, slow, vermicular type of plantar flexion. A slow, widespread withdrawal type of response, similar to the mass reflexes observed later on, was very seldom observed in the early period. With these exceptions, however, any type of reflex response in the acute phase of injury indicated a partial lesion.

Vasomotor changes were often noted in the early period after injury. The skin in the involved areas usually became cold and pale or mottled immediately; later, it became flushed, dry, and warm. Priapism was very infrequent, but lesser degrees of penile turgescence were commonly observed with both complete and partial transections.

Patients with injuries of the lumbar spine often exhibited neurologic findings which were incorrectly interpreted by the unwary examiner. The error could usually be avoided if it was remembered that the conus medullaris lies opposite the body of the twelfth thoracic vertebra and the interspace below it. Below this level, spinal injuries were associated with lesions of the cauda equina, so that, depending on which roots were involved, asymmetrical and bizarre neurologic pictures were frequently seen.

Repeated brief neurologic examinations at frequent intervals and by the same examiner were especially valuable in determining the exact level of a lesion as well as the improvement or progression of an incomplete lesion. It was extremely important to note on the patient's record the neurologic status at the time of each examination, especially in the forward areas, where movements of both patients and surgeons were frequent and often unforeseen.

LUMBAR PUNCTURE

Lumbar puncture to determine the character of the spinal fluid and estimation of dynamics (Queckenstedt's test) proved of no particular value in the early diagnosis or treatment of compound spinal injuries. In closed spinal lesions, the presence of a block of the subarachnoid space can be determined readily by this method and may be of importance in deciding upon laminectomy. In penetrating wounds of the spinal cord due to missiles, the same criteria are not present, as indicated by the following observations:

1. A metallic foreign body or a depressed bone fragment often encroached upon the spinal canal, causing local compression of the long tracts of the cord without producing demonstrable interference with the circulation of the spinal fluid.

2. A complete block to the circulation of fluid was sometimes produced in the first few days after injury by edema of the cord alone, in the absence of any extrinsic compression that could be alleviated by surgical intervention.

3. Manometry proved unsatisfactory whenever there had been penetration of the dura resulting in a spinal fluid leak.

4. The finding of blood in the subarachnoid fluid on lumbar puncture did not necessarily mean that dural penetration had taken place. Blood was often present after simple concussion or contusion of the cord, without direct involvement of the dural contents.

Lumbar puncture, therefore, did not help to differentiate anatomic from physiologic transection, or complete from partial transection, of the cord, nor did it aid in designating cases suitable for early laminectomy. For these reasons, spinal fluid studies were largely abandoned in forward hospitals.

Lumbar puncture was, of course, indicated in patients who showed clinical evidence of infection. If meningitis was established, lumbar punctures were continued for the intrathecal administration of penicillin one or more times daily in doses of 10,000 to 20,000 units.

Postoperative lumbar punctures were indicated only for the diagnosis and treatment of meningeal infection.

ROENTGENOLOGIC EXAMINATION

Even with the best equipment and technicians available, it is often difficult to obtain good roentgenograms of the spine, particularly in the thoracic and low cervical regions. In forward hospitals of combat zones, it was even more difficult to obtain satisfactory films for one or more of the following reasons:

1. Stereoscopic roentgenograms were not available; they would often have been of great value in locating protrusion of bone fragments and foreign bodies into the spinal canal.

2. The power available from portable generators varied considerably and caused technicians infinite trouble in estimating the time of exposure necessary.

3. In the rush of casualties which followed any heavy engagement, there was neither the time nor the personnel available to place patients in perfect position for roentgenograms.

It was often possible, however, in spite of these difficulties, to obtain fair, and even good, anteroposterior films. It was more difficult to obtain satisfactory lateral films. Operations for spinal injuries were never acute emergencies, and repeated roentgenograms often justified the additional time and effort expended to secure them.

Roentgenograms were never made until patients had been adequately treated for shock and until sufficient personnel were available to move them onto the X-ray table. Roentgenograms of the spine were always requested in accordance with the level of injury estimated by clinical examination rather than by the site of the external wound, since the spinal injury was often found at a considerable distance from the wound of entry or exit.

Although roentgenograms often did not show accurate bony detail at

the point of injury, they were invaluable in permitting deductions concerning the course taken by a penetrating missile. Anteroposterior and lateral films localized metallic foreign bodies well, and, when these films were considered in conjunction with clinical examination of the wounds of entrance and exit, with evaluation of the neurologic signs, wound tracks could usually be charted with considerable accuracy.

Metallic foreign bodies inside the spinal canal or impinging upon it could be identified readily (figs. 10 and 11). It was always extremely important to determine whether a metallic foreign body lay on the same side of the midline as the wound of entrance or on the opposite side. If it was on the opposite side, the spine was examined carefully for fracture along the calculated course of the missile (fig. 9B). When roentgenograms showed

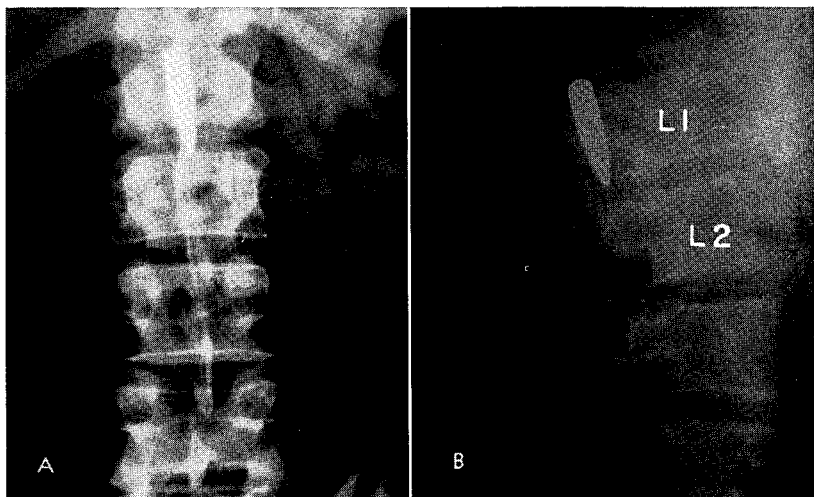

FIGURE 10.—Roentgenograms showing bullet lying free within spinal canal at L_1 and fracture of pedicle and lamina of L_2 . Preoperative weakness of the left leg was relieved completely following removal of the foreign body and depressed bone fragments. A. Anteroposterior view. B. Lateral view.

the foreign body on the same side as the wound of entrance, the surgeon could never assume that the spine was uninjured because foreign bodies very frequently ricocheted from the spine on the same side or bounced directly backward after causing a depressed fracture (fig. 9A).

It was often possible to see actual protrusion of depressed fragments of lamina or pedicle into the spinal canal. More often, however, these conditions were assumed to exist rather than actually visualized. It was the rule to find much more extensive bony comminution and depression at operation than had been predicted by examination of the roentgenograms.

LAMINECTOMY

Indications

The indications for operative intervention in the management of spinal injuries and the optimum time for it have always been controversial subjects. The exigencies of war made these problems even more difficult, for, in addition to the purely clinical indications for laminectomy, such other factors had to be considered as transportation and nursing facilities and the relative priority of these patients in commanding the time of the neurosurgical personnel available. It was necessary, therefore, to adopt some general policy, which was, of course, subject to modification by particular problems

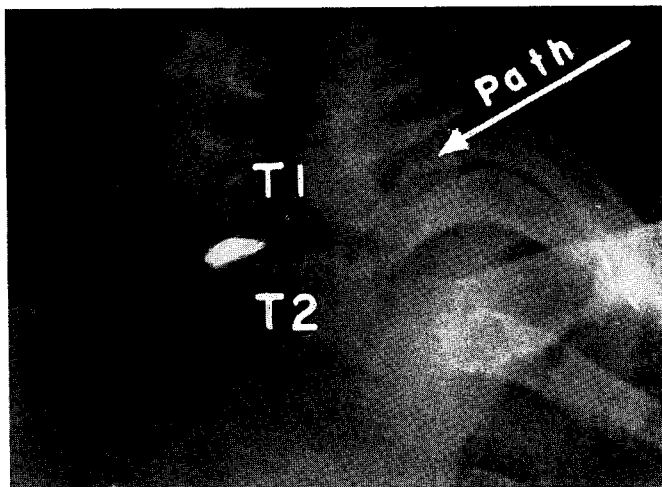

FIGURE 11.—Anteroposterior roentgenogram showing shell fragment on side of spinal canal opposite from wound of entry in neck. This roentgenologic observation, together with the clinical findings of complete physiologic cord transection, usually indicated a poor prognosis, although anatomic transection of the cord could be established only by laminectomy.

arising in unusual circumstances. In spite of the efforts of theater surgeons and consultants to standardize the treatment of these wounds, there was probably no type of war injury that received less uniform treatment at the hands of different surgeons. As has already been pointed out, there was considerable confusion after World War I regarding early surgical treatment of compound spinal wounds; much of this confusion was carried over to World War II. The actual difficulty in interpreting the clinical and roentgenologic findings and the variable tactical situations which arose, together with the existing confusion concerning the optimum form of therapy, all contributed to the lack of standardization in early treatment.

There were in reality two different problems, which, while separate, were still dependent on one another. The first problem was purely clinical: What were the actual indications for early laminectomy after compound spinal injury? The second problem was administrative as well as clinical: What was the level in the chain of medical evacuation at which laminectomy was best performed?

In compound wounds of the spine, as well as in all other compound injuries, some type of early operation was always indicated. Wounds of entrance and exit required debridement, at least.

Prevention of infection.—When there were sizable wounds directly over, or near, the spinal column, the only satisfactory way to perform an adequate debridement was to excise the wound to its depths and perform a formal laminectomy as widely as necessary to remove all comminuted and depressed bone fragments. This was especially true if the dura was open and a spinal fluid leak existed, as the following case history shows:

A U.S. Army sergeant was admitted to a field hospital in Belgium on 4 September 1945, alert, cooperative, and not in shock. He stated that immediately after wounding he had become completely numb from the nipple line down and had fallen to the ground at once.

Examination revealed a ragged 2.0- by 2.5-cm. wound of entrance directly over the fourth dorsal vertebra in the midline posteriorly, with leakage of spinal fluid. There was complete anesthesia below the fifth dorsal vertebra bilaterally, complete areflexia, complete flaccid paralysis of the abdomen and lower extremities, and retention of urine. Roentgenograms revealed a large metallic foreign body within the spinal canal at the level of the fourth dorsal vertebra.

Under local procaine hydrochloride infiltration, the wound was excised and extended. Comminuted fragments of the spine and laminae of the fourth dorsal vertebra were removed. A 1.5- by 2.5-cm. metallic foreign body was found to have passed directly through the spinal canal. It was dislodged from the body of the vertebra and removed. There was a large gap in the dura, and the cord was completely transected. After thorough debridement, a piece of fascia was placed over the gap in the dura, and the paraspinal muscles were approximated tightly over the bone defect. Penicillin and sulfanilamide powder were dusted into the outer layers of the wound.

The postoperative course was uneventful, and the wound healed primarily. Constant bladder drainage was maintained until evacuation. There was no change in the complete paraplegia.

When a spinal fluid leak persisted, it usually meant either that there was a large laceration of the dura or that a spicule of bone or a foreign body was protruding through the dura and thus maintaining the opening. Such an injury is illustrated by the following case:

A U.S. Army officer was received in an evacuation hospital in Germany on 11 December 1944, 24 hours after injury. There was a 1.5-cm. wound of entry directly over the midlumbar region, with gross leakage of spinal fluid. There was weakness of both lower extremities, but all motions could be performed. There was hypesthesia below the fourth lumbar vertebra bilaterally but no anesthesia. The patient was able to void spontaneously. His temperature was 101° F., and there was definite stiffness of the neck. Roentgenograms revealed a 1.0- by 1.0-cm. metallic foreign body in the spinal canal at the level of the third lumbar vertebra.

The patient was given penicillin and sulfadiazine systemically, and a large sterile dressing was applied to the wound of entrance after thorough cleansing of the surrounding skin. Three days later, fever and stiffness of the neck had disappeared, but spinal fluid still leaked from the wound. The weakness and sensory loss had almost completely disappeared.

Under local anesthesia, the wound was excised widely, and the incision was extended to expose the laminae of the second to the fourth lumbar vertebrae. A small metallic foreign body was found protruding through the dura at the third lumbar vertebra. It was removed, together with comminuted bone fragments. The dural opening was enlarged sufficiently to make certain there was no damage to the cauda equina. The dura was closed tightly, and the rest of the wound was closed in layers after subdural instillation of 10,000 units of penicillin. The postoperative course was afebrile and uneventful.

If wounds involved infected or contaminated paraspinal tissues as well as the dura, closure of the dura was essential to prevent meningitis. This was particularly true when missiles passed through the bowel first and then entered the spinal canal. The following case history illustrates this type of injury:

A staff sergeant was seen in consultation at a field hospital in Belgium on 6 January 1945. Two days earlier, he had been admitted in shock with a wound of entrance in the right anterior chest wall and with paraplegia. After shock therapy, a thoracoabdominal operation had been performed, with suture of a laceration of the lower lobe of the right lung, suture of two perforations of the small intestine, and suture of lacerations of the liver and the diaphragm. Constant bladder drainage was instituted. The postoperative course had been satisfactory, but the paraplegia had remained unchanged.

Examination revealed sensory and motor loss at the fourth lumbar vertebra on the right and at the second lumbar vertebra on the left. Roentgenograms revealed a small-caliber bullet in the region of the spinal canal at the third lumbar vertebra, with fractures of the bodies and pedicles of the second and third lumbar vertebrae on the right.

Approximately 72 hours after the thoracoabdominal operation, laminectomy was carried out under local procaine hydrochloride infiltration. The bullet was found protruding into the dura, with gross leakage of spinal fluid into the paraspinal tissues. About half of the roots of the cauda equina were divided, and half were intact. Several tiny pieces of clothing and debris were removed from within the dura. All comminuted bone fragments were removed, and the dura was closed with a fascial graft. Penicillin and sulfanilamide powder were dusted into the wound, which was closed tightly.

Although the patient was not seen again by this particular surgeon, he was reported convalescing satisfactorily 8 days after operation, though at this time there was no change in the neurologic picture.

Relief of root pain.—Occasionally, a compound wound of the lumbar spine or sacrum was observed, with involvement of the cauda equina, in which the patient experienced severe radicular pain. The presence of pain was always evidence of an incomplete transection. The pain might even grow more severe while the neurologic deficit receded. According to Pool, in four out of five patients with root pain, pain was relieved by operation. Since this type of pain was very severe and was usually untouched by ordinary medication, early operation was indicated. An example of such an injury follows:

A technical sergeant was admitted to a field hospital in Germany on 20 March 1945, with a wound of entrance through the right side of the abdomen and a wound of exit in

the midlumbar region. There was partial paraplegia, with retention of urine. After preliminary shock therapy, laparotomy was carried out with suture of one perforation of the stomach and two of the duodenum and repair of a laceration of the liver. The exit wound in the lumbar region was debrided superficially.

The postoperative course was satisfactory, and there was definite improvement in the motor power of both lower extremities, as well as in sensation. The patient, however, complained increasingly of radiating pain down the back of the right leg and the lateral aspect of the foot. When he was seen in consultation on the seventh day after laparotomy, this pain was very severe. Roentgenograms revealed a comminuted fracture of the vertebral arch of the fourth lumbar vertebra. There was loss of function below the fifth lumbar vertebra on the right and the first sacral vertebra on the left.

On the following day, under local procaine hydrochloride infiltration, the old wound of exit in the midline was excised and extended. Severely comminuted fragments of the spine, laminae, and pedicles of the fourth lumbar vertebra were removed from their encroachment on the spinal canal. The dura was lacerated on the right side, and roots of the cauda equina had herniated through the dural defect. They appeared badly contused and edematous but were intact. After replacement of the cauda equina, the dura was sutured. Penicillin and sulfanilamide powder was dusted in all layers of the wound after closure of the dura, and closure was effected in layers. Because this was a reopened wound, a slip drain was left beneath the fascia for 48 hours.

The patient was dramatically relieved of most of his pain immediately after operation and remained free of it up to the time of his evacuation 5 days later. There was no change in his neurologic status during this time. Constant bladder drainage was maintained.

Decompression of the spinal cord and cauda equina.—The importance of extrinsic pressure on the spinal cord by bone fragments or metallic foreign bodies has always been a subject of great controversy. For this reason, it was difficult to define and establish a uniform policy of treatment. As experience accumulated during the war, however, certain criteria for operation were adopted by most neurosurgeons and are worth presenting in some detail.

In general, it was thought that laminectomy for purely decompressive purposes was indicated early in certain types of cases but that these cases did not constitute the surgical emergencies which they had often been considered. Pool stated that laminectomy could be postponed safely, to allow cardiorespiratory stabilization, without jeopardizing the chances for subsequent neurologic improvement, and that the general condition of the patient rather than the neurologic status should determine the optimum moment for operation. Haynes, though he believed that the pressure of bone, debris, and foreign bodies should be removed early, preferably within 48 hours, also stated that the prognostic difference between operation at 48 hours and at 10 days was of minimal significance. Matson believed that operation purely for purposes of decompression was probably the least urgent reason for early laminectomy, but he thought that decompression should be carried out as soon as feasible in all instances in which local compression of the spinal cord was suspected or was actually demonstrable.

Early laminectomy for relief of local compression was considered particularly desirable for spinal injuries in the following types of patients:

1. Patients who exhibited a neurologic picture consistent with incomplete transection of the cord and in whom the picture had definitely altered since the time of injury, especially if the neurologic deficit had increased. These cases were extremely uncommon, which lends weight to the belief that the greater part of the physiologic loss was due to damage produced at the moment of injury rather than caused by subsequent compression. Even in patients showing improvement, however, recovery might well stop short of the maximum possible if cord compression remained, and it was therefore the policy to relieve it as soon as possible.

2. Patients with a neurologic picture of fixed but incomplete cord transection, whose roentgenograms revealed clear-cut encroachment on the spinal canal by a metallic foreign body or a definite fracture of the lamina or pedicle with or without depression of bone fragments. It should be pointed out again that detail was poorly visualized in these roentgenograms and that almost invariably there was more comminution and depression of fractures than was evident in the roentgenograms. A Brown-Séguard type of incomplete lesion was occasionally seen and appeared to indicate an especially favorable prognosis. The following case is an example of such an injury:

A U.S. soldier was admitted to an evacuation hospital in Germany on 21 March 1945. He was alert, cooperative, and not in shock. There was a ragged wound of entrance 2.0 by 3.0 cm. on the left arm just below the shoulder, with inability to use this extremity. The man was also unable to move the left lower extremity, though there was some tone present in the muscles. On the right side, there was absence of pain sensation in the trunk and lower extremity and some weakness of the leg. Sensation on the left was normal.

Roentgenograms revealed comminuted fractures of the neck of the left humerus and the left scapula, together with fractures of the spines and pedicles of the fifth and sixth cervical vertebrae on the left. There was a metallic foreign body in the soft tissues of the neck to the left of the midline.

Under local procaine hydrochloride infiltration, supplemented by intravenous thio-pental sodium (Pentothal sodium) anesthesia, a midline incision was made from the spines of the fourth to those of the seventh cervical vertebra. The fractured spines of the fifth and sixth cervical vertebrae were removed, together with comminuted depressed fragments of the sixth cervical lamina on the left. The dura was intact and did not appear contused. Clear, colorless spinal fluid was aspirated from the subarachnoid space through a hypodermic needle, and the dura was therefore not opened. The foreign body was removed from the soft tissues of the neck, and the wound was closed in layers without drainage. The wound of entrance was then debrided, and a thoracobrachial plaster spica was applied.

By the time the patient reacted from the anesthesia, there was already improvement in the motion of the left leg, and by the time of evacuation, on the sixth day, there was almost complete recovery of sensation on the right as well as of motion on the left.

3. Patients with a neurologic picture of complete physiologic transection of the cord, with roentgenograms showing the presence of a metallic foreign body within, or protruding into, the spinal canal, as well as patients who had demonstrable fractures with depression of bone fragments into the canal.

If a metallic foreign body lay on the same side of the spinal cord as the wound of entrance, the prognosis was considered more favorable than if it had crossed the midline. What appeared to be complete immediate physiologic transection was not necessarily a contraindication to early laminectomy, provided that examination of the wound and of the roentgenograms indicated that a favorable situation might be present. While the presence of such an immediate complete physiologic transection always carried an extremely guarded prognosis, it did not necessarily indicate a hopeless outcome; an occasional patient showed significant improvement during a time interval which made it reasonable to assume that operation had permitted, or at least hastened, this course. Tinsley reported laminectomies on 19 patients with complete physiologic transections, with early postoperative improvement in two. Haynes also reported early improvement in patients with apparently complete physiologic transections. Matson observed two patients who showed some return of function following early laminectomy, although preoperatively they had been considered to have complete physiologic transections. McCravey⁹ reported that one out of six patients with complete immediate physiologic transection exhibited subsequent improvement. At any rate, it may be concluded from these observations that, if examination of the patient and of the roentgenograms left any reasonable doubt in the surgeon's mind that the cord had been severed, there was nothing to lose and there might be much to gain by early relief of localized cord compression.

4. Patients with a history and neurologic picture of immediate complete cord transection who had through-and-through wounds traversing the spinal canal or patients whose roentgenograms showed gross fractures of one or more vertebrae with obliteration of the spinal canal by bone fragments. Lowest priority for early operation was given to these casualties. Even in this group, however, complete physiologic transection did not necessarily mean anatomic transection, as is illustrated by the following case:

A U.S. soldier was admitted to a field hospital in Belgium on 12 September 1944, in good general condition. There was a 1.5-cm. wound of entrance in the right side of the neck anteriorly and a 2.5-cm. wound of exit in the middorsal region opposite the fourth and fifth dorsal vertebrae. There was complete flaccid paralysis of the abdomen and lower extremities, complete loss of sensation below the nipple line, areflexia of the lower extremities, priapism, and retention of urine. Spinal fluid leaked profusely from the wound of exit. There was no evidence of penetration of any vital structures of the neck or mediastinum.

Under procaine hydrochloride anesthesia, the wound of exit was excised and extended, so that the spine and fractured laminae of the fourth and fifth dorsal vertebrae could be removed. A dural laceration on the right side was extended, so that intradural exploration within could be carried out. The cord was markedly contused, hemorrhagic, and edematous but was anatomically intact. The dura was sutured and the wound closed in layers after being dusted with penicillin and sulfanilamide. The entrance wound was then debrided.

⁹ McCravey, A.: War Wounds of Spinal Cord; A Plea for Exploration of Spinal Cord and Cauda Equina Injuries. *J.A.M.A.* 129: 152-153, 8 Sept. 1945.

This patient was evacuated 5 days after operation, at which time he showed no evidence of any return of function. His wound appeared well healed. Constant bladder drainage was maintained.

5. Patients with wounds of the lumbar region of the spine which involved the cauda equina. Except in the presence of severe root pain, these wounds were not considered to be as urgent as similar wounds of the cervical and thoracic vertebrae with involvement of the spinal cord proper.

Exploration.—It must again be emphasized that in the acute stage of injury, clinical findings, roentgenographic studies, and lumbar puncture did not give a true picture of the pathologic changes, nor could they be relied upon to determine the prognosis. Every patient with a demonstrable compound wound of the spine and abnormal neurologic findings therefore should at some time have had the benefit of exploratory laminectomy.

Spinal cord concussion.—A temporary and reversible interruption of physiologic function of the spinal cord may occur as a result of severe trauma in the region of the spinal column, without actual mechanical pressure on the cord or gross anatomic changes within its substance. This injury was recognized in World War I, as well as in civilian practice, and has become known generally as spinal cord concussion. In World War II, it was observed frequently, usually following passage of a high-velocity missile close to the spine, with or without production of a fracture of a spinous or transverse process but always without direct involvement of the cord. It is assumed that, in such cases, the interruption of function is due to a wave of pressure transmitted from the pathway of direct injury to the cytoplasm of neuronal elements within the cord.

Recovery from spinal cord concussion often began within a few hours. Maximal if not complete recovery usually occurred within the first 1 to 3 weeks, but improvement was sometimes observed to continue for months.¹⁰ Decompression by removal of normal laminae of a cord that had sustained concussion was thought to be of no avail. Any improvement which followed such an operation undoubtedly would have occurred anyway in about the same period of time. In the absence of any roentgenologic or other evidence of vertebral fracture or of encroachment upon the spinal canal, there was no indication for early laminectomy at the site of a clinical level of physiologic transection. This decision implied completely negative roentgenograms or other definite evidence that the spinal column was not directly involved.

Administrative Considerations in Early Laminectomy

Unfortunately, it was not always possible during World War II to proceed with the management of cord injuries on the basis of purely clinical judgment. Because of the rapid movements of the battlefield, it was neces-

¹⁰ (1) See footnote 5 (3), p. 32. (2) Baker, G. S., and Daniels, F., Jr.: Concussion of the Spinal Cord in Battle Casualties. *J. Neurosurg.* 3: 206-211, May 1946. (3) Livingston, W. K., and Newman, H. W.: Spinal Cord "Concussion" in War Wounds. *West. J. Surg.* 54: 131-139, April 1946.

sary for medical units in forward areas to be mobile. It was often necessary to transport patients long distances before fixed installations could be reached. These considerations frequently played a necessary part in the decision to carry out laminectomy at any given time or in any given hospital.

Particularly because of the problems involved in postoperative nursing care of casualties with cord injuries, every effort was made to move these patients to a fixed neurosurgical center in the rear as soon as possible, whether or not operation was performed in a forward area. Although they traveled fairly well during the first few days after laminectomy, provided that there were no complicating injuries of the chest, abdomen, or head, in general it was better to transport them to the rear before laminectomy if this was practical within a reasonable length of time. If, however, the transportation facilities were so poor or the chain of evacuation was so uncertain as to prohibit removal to a general hospital within 48 to 72 hours, then operation on patients in the categories just outlined was indicated in forward areas.

A considerable number of compound spinal injuries were associated with penetrating wounds of the chest, abdomen, or pelvis. Patients with the latter injuries were considered nontransportable for 8 to 10 days after operation, and they were held in field and evacuation hospitals for this period of time unless the military situation required earlier evacuation. It was therefore necessary to perform laminectomy on these patients in the forward areas unless operation was to be delayed beyond the 10-day period. Laminectomy was never carried out before, or at the same time as, an open chest or abdominal procedure. It was usually possible, however, to perform it within 48 to 72 hours after a chest or abdominal operation had been completed, and certainly within the 10-day period. When spinal wounds were associated with massive hemothorax, laminectomy was delayed until respiratory stabilization was achieved. Maintenance of systemic chemotherapy or antibiotic therapy permitted this delay without undue hazard of infection. The following case history illustrates the management of such an injury:

A U.S. Army corporal was admitted to an evacuation hospital in Belgium on 20 September 1944, in moderate shock. He was alert and cooperative but had moderate respiratory difficulty. There was a 1.5-cm. wound of entrance at the apex of the right shoulder. There was an incomplete motor paralysis of the lower extremities, a sensory loss at the ninth and tenth dorsal vertebrae, and retention of urine. Roentgenograms taken after treatment of shock revealed a massive hemothorax on the right side and a small-caliber bullet imbedded in the same side of the vertebral arch of the tenth dorsal vertebra.

Oxygen was administered by the intranasal route, and 500 to 600 cc. of blood were aspirated from the chest. These measures somewhat improved the respiratory status. Several hours later, the patient was taken to the operating room and placed in the face-down position in preparation for laminectomy. In this position, however, his respirations became more difficult, his pulse rapid, and his color slightly dusky. He was therefore taken back to the shock ward and kept in Fowler's position while intranasal oxygen was continued. During the next 24 hours, aspiration of the chest was repeated twice, with removal of 600 to 800 cc. of blood each time, and two transfusions of whole blood were given.

At the end of this time, laminectomy of the ninth and tenth dorsal vertebrae was carried out satisfactorily under local procaine hydrochloride anesthesia. A 30-caliber bullet was found protruding into the spinal canal, compressing the dura sharply toward the left. Careful exploration after removal of this slug and several comminuted bone fragments revealed the dura to be intact. The connection with the pleural cavity, which had been sealed, was not reopened. The wound was closed tightly in layers.

Postoperatively, aspiration of the chest was repeated three more times. The patient's convalescence was otherwise uneventful, and he showed definite neurologic improvement at the time of evacuation on the tenth day. Constant bladder drainage was maintained.

Occasionally, patients with spinal injuries were considered nontransportable because of other injuries, such as extensive burns, compound fractures of the femur, penetrating wounds of the brain, or severe maxillofacial injuries. Here too, if early laminectomy was indicated, it was performed under appropriate anesthesia as soon as the patient's general condition permitted it.

Anesthesia

Three types of anesthetic agents were generally employed for early laminectomy, depending upon the character and location of the wound, the anesthetic facilities available, and the individual preference of the surgeon. These included (1) local 1 percent procaine hydrochloride, (2) intravenous 2.5 percent thiopental sodium, and (3) intratracheal gas-oxygen-ether.

Premedication.—Morphine sulfate, in doses of 11 to 16 mg., was usually given preoperatively to patients with injuries in the thoracic and lumbar regions. It was given subcutaneously 45 to 60 minutes before operation, or, more often, intravenously, just as the patient was placed on the operating table. Morphine was never given preoperatively to patients with injuries of the cervical region, nor was it given to patients with any respiratory depression or irregularity.

Pentobarbital sodium (Nembutal) by mouth or amobarbital sodium (Amytal sodium) subcutaneously, in doses of 0.1 to 0.2 gm., was often used to good advantage 1 to 1½ hours before operation, to relieve anxiety and restlessness. In the presence of injuries of the cervical portion of the spinal cord or any evidence of respiratory depression, the barbiturates were either withheld or were administered with extreme caution. Atropine sulfate, 0.45 to 0.65 mg., was given routinely before operation whenever general anesthesia was contemplated.

Since pain was seldom severe and often was completely absent, because of the anesthesia produced by the cord injury itself, large amounts of drugs for premedication were seldom necessary. Root pain at this stage was uncommon, though it was occasionally seen in cauda equina injuries. Severe root pain responded poorly to ordinary medication and itself constituted an indication for early operation.

Local anesthesia.—In most instances, local was the anesthesia of choice for formal laminectomy. As long as the operation was carried out in the midline, only small amounts of the anesthetic agent were needed. Often, the

area of operation was already partly or completely anesthetic. Sometimes, however, it lay in the zone of hyperesthesia found just above the level of anesthesia. If debridement of wounds of entrance or exit away from the midline was also necessary, then local infiltration with procaine alone was usually unsatisfactory, and thiopental sodium in small amounts was administered intravenously, as necessary, to supplement the local anesthetic.

One percent procaine hydrochloride (Novocain), to which epinephrine (Adrenalin), 0.18 to 0.3 cc. per 30 cc. of 1:1,000 solution, had been added, was routinely used. The skin along the line of incision was thoroughly infiltrated, after which approximately 5 cc. of procaine was injected beneath the fascia on each side of each spinous process. This anesthesia was usually sufficient for the entire procedure unless manipulation of sensory nerve roots at the level of injury was necessary.

Local procaine hydrochloride infiltration was used routinely by some surgeons even when general anesthesia was employed, since it lessened the amount of the general agent necessary and proved of substantial aid in local hemostasis.

Thiopental sodium (Pentothal sodium).—Intravenous thiopental sodium in 2.5-percent solution was widely used by many surgeons as the principal anesthetic agent, as well as to supplement local infiltration for short periods. It could also be given satisfactorily in a continuous intravenous drip of 0.5- to 1-percent solution. Its use demanded the presence of a competent anesthesiologist to observe the patient's airway and vital signs, to administer oxygen when necessary, and to insure an even level of anesthesia.

Thiopental sodium was contraindicated in injuries involving the soft tissues of the neck or the cervical portion of the spine. It was also contraindicated in the presence of associated penetrating wounds of the chest and in all instances of respiratory depression or irregularity, whatever the cause.

When thiopental sodium was employed, it was especially important that correct positioning on the operating table be achieved, with the lower part of the chest and the abdomen free from compression and the nasopharynx and trachea free from obstruction. It was usually found desirable to induce anesthesia to a satisfactory level with the patient on his back. Then he was turned to the prone position, his head and shoulders were positioned, and his airway, respirations, and color were observed in this position for a few moments before he was covered with drapes and the operation was begun.

Thiopental sodium was especially valuable when soft-tissue wounds or fractures elsewhere had to be debrided at the same time as the spinal wound. Its principal use by Matson was for wounds in the lumbar region when no respiratory complications were present.

Ether.—Inhalation anesthesia through an intratracheal tube was usually the anesthesia of choice in penetrating wounds of the chest which involved the thoracic region of the spine. During laminectomy on a patient with such an injury, the operative wound could have been converted, necessarily or

inadvertently, into a sucking wound of the chest because of a pleural communication produced by the missile. The advantage of positive pressure under such circumstances is self-evident.

Intratracheal gas-oxygen-ether anesthesia was also preferred for operations in the low cervical region when paralysis of the accessory muscles of respiration was present, especially if large amounts of secretion had accumulated in the respiratory tree. This method allowed control of respirations during possible periods of temporary arrest due to operative manipulations in the region of the cervical portion of the cord. It also permitted thorough aspiration of the pharynx and trachea before and during operation.

Care of patient at operation.—Throughout all spinal operations, careful observations of the pulse, respirations, and blood pressure were made whenever possible. An intravenous needle was inserted before operation, and suitable fluid was continuously administered. Blood loss was replaced immediately by whole blood, and other supportive treatment was given as indicated.

Positioning

Patients with spinal injuries were routinely operated on in the prone position. Considerable attention was devoted to proper adjustment of this position, regardless of the anesthesia used. If local anesthesia was employed, it was important that the patient be made as comfortable as possible, since the operative procedures were usually fairly long. It was also essential to make certain that prominent areas in the zone of anesthesia, such as the iliac crests, shins, and dorsum of the ankles, did not rest against any hard surface during operation.

Whenever it was available, a cerebellar type of headrest was used, thus allowing the patient's head to be kept in the midline in a comfortable position. In laminectomies of the cervical and upper thoracic regions, this was essential. In the absence of a cerebellar headrest, a support for the forehead was improvised by making a sling between the handles of the standard army litter.

The most important point in arranging the position of these patients, however, was sufficient elevation of the shoulders from the operating table or litter to permit easy respiratory excursion of the diaphragm. It was essential to be able to slip the flat of the hand under the chest and upper part of the abdomen at all times. This position was readily achieved by placing a long, narrow sandbag, hard pillow, or tight small blanket roll diagonally under each shoulder. Constant bladder drainage was maintained throughout operation.

Preparation of the Surgical Field

With the patient in a satisfactory position, the operative area was scrubbed thoroughly with soap and water, followed by alcohol and bichlo-

ride of mercury or by a 0.5-percent iodine solution or tincture of thimerosal (Merthiolate), according to the surgeon's preference. Suitable drapes were applied to isolate the operative site and any wounds requiring separate debridement.

Technique

No attempt will be made to describe in detail the steps of a laminectomy, since standard techniques were used in these operations.

Incision.—In cases which were suitable for early laminectomy, it was only occasionally that more than one or two vertebrae were involved, so that, provided the incision was properly placed, a large exposure was usually unnecessary. If, however, the external wound was even a short distance away from the midline, it was debrided separately, and laminectomy was carried out through a fresh exposure (fig. 12 A). If there was a wound of entrance or exit directly in the midline, it was included in the operative incision, and complete excision of the wound margins was carried out as the operative exposure proceeded (fig. 12 B).

The skin incision was made with digital pressure on the wound edges to minimize hemorrhage (fig. 13 A). Subperiosteal reflection of the muscles from the spines, intervertebral ligaments, and laminae was carried out with the aid of a broad, sharp periosteal elevator (fig. 13 B). Since this step is the most shock-producing part of a laminectomy, it was limited, whenever possible, to one vertebra above and one below the involved segments. Bleeding was controlled at each step with suction, pressure, and electrocautery, and self-retaining retractors were introduced to maintain the exposure (fig. 13 C). It was usually necessary to remove one or more vertebral spines, whether or not they were previously fractured, in order to gain adequate exposure of the involved structures.

Removal of bone fragments and foreign bodies.—The most important aim in early posttraumatic laminectomy was the visualization and complete removal of all comminuted and depressed bone fragments and of all metallic or other foreign bodies which encroached upon the lumen of the spinal canal. In addition, contaminated and devitalized tissues were removed as thoroughly as possible.

The same principles were applied in the operative management of depressed fractures of the spine as in depressed skull fractures. The most important was obtaining adequate exposure before attempting to remove bony fragments or impacted foreign bodies. This was necessary to minimize the danger of additionally injuring nervous tissue or of causing concealed hemorrhage which would be difficult to control.

Laminectomy could sometimes be started easily and safely at the site of the traumatic bony defect by gently teasing out loose fragments and then enlarging the opening with suitable rongeurs (fig. 13 D). If the traumatic defect was small or the fragments were impacted, it was usually easier and

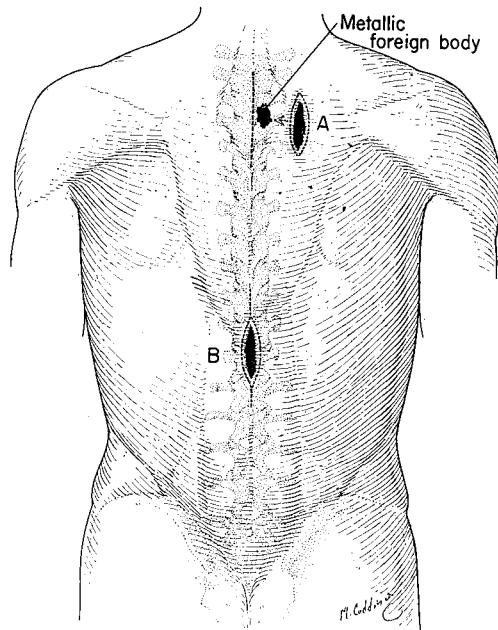
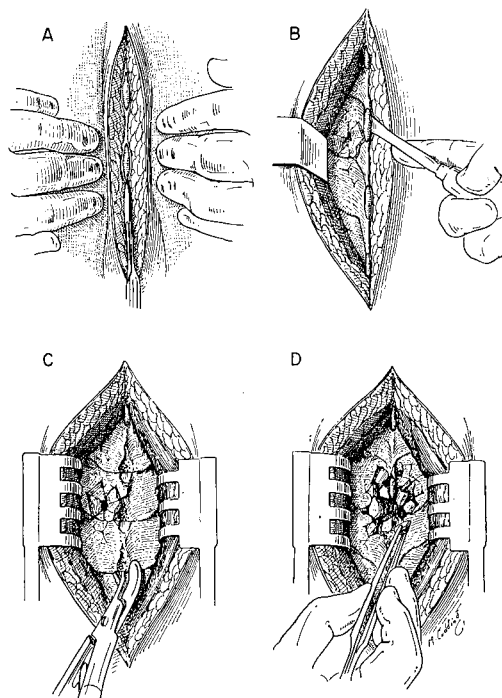

FIGURE 12.—Incisions for laminectomy. A. Incision used for separate debridement when wound of entrance or exit was located at distance from midline of back. Formal laminectomy in this type of injury was carried out through a fresh operative approach. B. Incision used when wound of entrance or exit was located in midline. In this type of injury, the wound was excised in the surgical incision and was extended sufficiently to permit adequate exposure of the spinal wound.

FIGURE 13.—Surgical exposure of spinal wounds. A. Midline incision carried down to vertebral spines, with bleeding controlled by digital compression of wound margins. B. Reflection of paraspinal muscles from spines and laminae on left, revealing penetrating wound of vertebral arch. Subperiosteal reflection of paraspinal muscles on right, beginning at tip of spinous process. Note broad, sharp periosteal elevator used for this step of the procedure. C. Exposure completed by removal with heavy rongeurs of 3 spinous processes. In this type of impacted fracture, bony removal of 2 adjacent laminae was most easily and safely begun at the distal margin of the lower lamina. D. More extensive spinal wound, in which debridement has been begun by removal of loose, comminuted fragments of lamina and pedicle. The operation is completed by rongearing all contaminated bony margins until a smooth defect is obtained.



safer to begin removal of bone at an uninjured point, usually the distal edge of an adjacent lamina (fig. 13 C). Every precaution was taken to protect the dura and any exposed nervous tissue with moist cotton as the bone was removed. Small amounts of extradural blood clot were frequently found and removed, although it was never thought that enough extradural hematoma was present to produce significant local compression by itself. Wide decompression of the spinal canal by removal of additional uninjured laminae was not believed to be necessary. An effort was always made, however, to remove sufficient bone to permit assurance that displacement of the dural envelope from every aspect had been relieved.

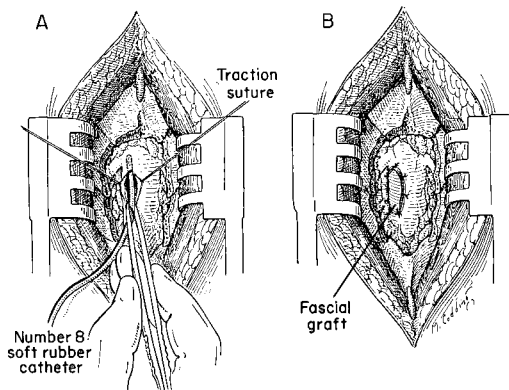
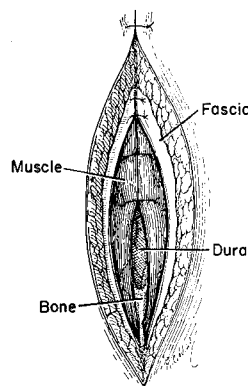

FIGURE 14.—Technique of laminectomy. A. Exposure of dural wound after removal of all depressed and comminuted fragments and rongeur-ing of contaminated bony margins. Traction sutures have been placed through the edges of the dural laceration to facilitate exposure for debridement within the dura. A No. 8 soft rubber catheter is passed up and down the subdural space to make certain all extrinsic compression on the cord has been relieved. B. Closure of dura by tacking fascial graft to margins of defect with fine silk sutures.

FIGURE 15.—Composite picture illustrating careful closure of operative wound in layers. When complete closure of the dura was impossible, tight approximation of the paraspinal muscles and fascia in the midline proved especially important.



Management of dura.—If the dura had been penetrated, exploration within it was always carried out. Whenever possible, this was done through the laceration itself. If this was not possible, the dura was opened in the midline in the standard fashion. Intradural operation was limited to the removal of bone chips, macerated tissue, foreign bodies, and blood clot. Operative manipulation of the cord itself, which was not believed to be of

any value, was avoided. No subdural hematomas were of sufficient extent to cause local compression in themselves. A small soft rubber catheter was passed upward and downward to make certain that there was no unexposed encroachment on the cord (fig. 14 A). The use of the electrocautery intradurally was avoided. Bleeding from the cord was controlled with pressure by moist cotton pledgets and the application of tiny muscle stamps or of fibrin foam when it was available. For the record, an attempt was made to estimate the extent of contusion and laceration of the cord or cauda equina.

Every effort was made to obtain a tight closure of the dura. Small round needles and fine silk facilitated this procedure. If dural defects remained, a free graft of fascia was cut from the paraspinal muscles. Many times, such a graft could not be sutured in a watertight manner, but it could usually be tacked in position with a few fine silk sutures (fig. 14 B). When the dural defect extended to the anterior aspect of the cord, a fascial graft was usually necessary, supplemented by a tight approximation of the paraspinal muscles above this area.

There was considerable difference of opinion in World War II, as there had been previously, whether dura which had been depressed and contused but not penetrated should be opened at operation. Since the spinal cord itself does not respond to any operative manipulation and since bleeding in the subarachnoid space is distributed longitudinally without local extramedullary clot formation and compression, there would appear to be no therapeutic reason for opening the dura when it is certain that it has not been penetrated. It has been argued that it is of considerable prognostic importance in subsequent management of the patient to inspect the cord at the point of injury. This might be true when anatomic destruction of the cord could be visualized directly, but this type of destructive injury was extremely infrequent in the presence of an intact dura. On the other hand, if the cord was not divided, even direct inspection of the amount of edema, contusion, and intramedullary hemorrhage present did not furnish a reliable indication of what future function might be.

One reason for not opening the dura was the possibility of introducing contaminated material into a previously clean subarachnoid space. There was also the risk of additional damage by any manipulation of an edematous, contused cord. There seemed, therefore, to be little indication for opening the dura if it had not already been penetrated.

Closure of wound.—Careful approximation of the paraspinal muscles in the midline in the region of the bony defect was always carried out. This was necessary to obliterate dead space in the wound, as well as to prevent the formation of a cerebrospinal fluid fistula when the dura could not be closed accurately. Unless gross sepsis was present, laminectomy wounds were closed in layers with silk sutures, without drainage (fig. 15). If a contaminated wound had been excised through the operative incision, the skin and subcutaneous tissues were sometimes left open, but the muscles and

fascia were carefully approximated. When wounds of entrance or exit were debrided separately from the operative approach for laminectomy, they were handled like all soft-tissue wounds except that, if the dura had been penetrated, the muscular and fascial layers were closed, to prevent spinal fluid leakage.

Local chemotherapy.—There was considerable variation in the use of local chemotherapy by individual surgeons. It became a common practice, after closure of the dura, to dust all layers of the wound with a powder made by mixing 1 gm. of sulfanilamide with 5,000 units of penicillin. Penicillin in liquid form, well diluted (1,000 units per cubic centimeter), was sometimes introduced into the subarachnoid space. In some theaters, local sulfonamide therapy was not used at all, and a sulfonamide was never introduced beneath the dura. The general conclusion was that, as in cranio-cerebral wounds, penicillin locally, plus penicillin and sulfadiazine systemically, provided the most satisfactory routine of chemotherapy.

Hemilaminectomy

Occasionally, a small spinal wound could be debrided satisfactorily through a unilateral approach (fig. 16). The standard exposure for removal

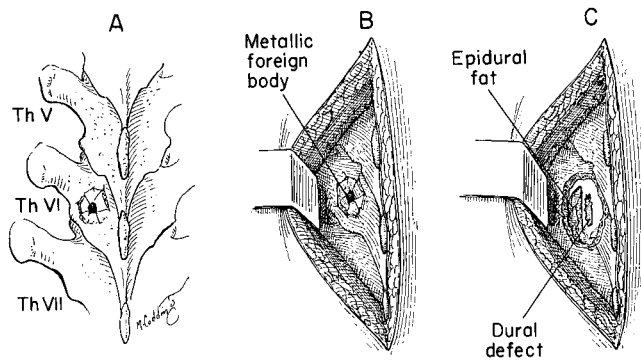

FIGURE 16.—Surgical exposure for hemilaminectomy. A. Location and size of wound suitable for management by hemilaminectomy. B. Reflection of paraspinal muscles subperiosteally from one side only of spinous processes and laminae, to reveal the small spinal wound. C. Exposure of small dural laceration after debridement of depressed fracture and removal of metallic foreign body. This small laceration can be readily sutured through this limited approach.

of a herniated intervertebral disk or for unilateral cordotomy was found applicable in these cases. Subperiosteal dissection of the muscles from the vertebral spines and from the laminae on one side only was carried out, and a deep retractor was used to maintain the exposure (fig. 16 B). Removal of one or more laminae could then be accomplished as necessary, followed by

debridement of the dural wound (fig. 16 C). If intradural exploration of any extent proved necessary, it was usually more satisfactory to do a bilateral laminectomy than to attempt operation through this limited exposure. The following case history illustrates the use of hemilaminectomy:

A U.S. soldier was admitted to an evacuation hospital in Germany on 17 March 1945, with paralysis of both lower extremities. He was alert, cooperative, and not in shock. There was incomplete sensory loss at the first lumbar vertebra bilaterally, areflexia of the legs, and retention of urine. There was a ragged wound of entrance in the upper lumbar region on the right, about 1 inch from the midline. Roentgenograms revealed a metallic foreign body lying opposite the body of the twelfth thoracic vertebra on the right, in the paraspinal muscles. They also showed a comminuted fracture of the transverse processes, laminae, and pedicles of the twelfth dorsal and first lumbar vertebrae on the right, with a fracture of the neck of the twelfth rib.

Constant bladder drainage was instituted by means of an indwelling catheter. There was no blood in the urine. Under local procaine hydrochloride anesthesia, supplemented by a small amount of intravenous thiopental sodium, the wound margins were excised and extended in the midline. The paraspinal muscles were reflected from the spinous processes and laminae from the eleventh dorsal to the second lumbar vertebrae on the right side. The spines were not fractured, but comminuted and depressed fragments of the transverse processes, pedicles, and laminae of the twelfth dorsal and first lumbar vertebrae were removed, as well as the comminuted medial end of the twelfth rib. A 2.0- by 1.5-cm. metallic foreign body and several small pieces of cloth were removed from the bony defect, which was then made smooth by rongeur-ing the margins of the adjacent laminae. The dura, which was explored carefully and found intact, was not opened. The pleura was also intact. There was no evidence of injury to the kidney. Penicillin and sulfanilamide powder were dusted into all layers of the wound, which was closed tightly in layers with silk.

The postoperative course was uneventful. Definite improvement in sensation, without return of motor power or reflexes, was observed up to the time of evacuation on the sixth day.

POSTOPERATIVE CARE

No less important than operation in the early management of spinal injuries were nursing and supportive care. This was true whether or not early laminectomy had been performed. In hospitals in the forward areas, where personnel and facilities were necessarily limited, the care of these patients provided an especially difficult problem. The general principles of good postoperative care of any major surgical procedure applied to these injuries.

Routine Measures

Fluid administration.—Fluids were administered orally and parenterally to maintain normal hydration and an adequate urinary output; this usually meant the administration of 2,000 to 3,000 cc. daily. Transfusions of whole blood were given to replace depleted hemoglobin and red cells. Plasma and whole blood transfusions were also used to bolster falling serum protein levels.

Sedation and control of pain.—Barbiturates and paraldehyde were administered for restlessness and sleeplessness. Codeine and morphine in stand-

ard doses were used for pain except in injuries of the cervical portion of the cord and instances of respiratory depression. While the spinal injury itself was not often painful, associated wounds frequently were.

Chemotherapy and antibiotic therapy.—Since nearly all spinal wounds were compound fractures, casualties routinely received postoperative systemic penicillin therapy. Penicillin was given in doses of 20,000 to 40,000 units every 3 hours and was continued for at least 5 to 7 days. If the dura had been penetrated, it was usually administered for 7 to 10 days. If a spinal fluid fistula persisted, penicillin was continued for longer periods. If clinical signs of meningitis developed, penicillin was continued systemically and was also injected intrathecally by the lumbar route in doses of 10,000 to 20,000 units once or twice daily. Intrathecal penicillin was introduced in a solution of 1,000 units per cubic centimeter of spinal fluid or physiologic salt solution.

During the early postoperative period, sulfadiazine also was given by most surgeons, in doses of 4 to 6 gm. daily and was continued in smaller doses as long as constant bladder drainage was continued.

When early postoperative evacuation became necessary, it proved especially important to arrange for uninterrupted chemotherapy during transportation.

Special Postoperative Problems

Certain specialized problems in the management of spinal cord injuries must be considered in more detail.

Position.—Air and water mattresses were not available in forward hospitals in the early fighting on the Continent. Some forward hospitals, in fact, had no mattresses at all. Beds were not available, but the standard army cots and litters were always provided. After operation, the patient was transferred to a cot, with a mattress if it were available. If no mattress was available, one was improvised by placing on the cot at least three folded blankets covered by a tightly stretched clean, dry sheet.

Measures to prevent hypostatic pneumonia were imperative in the first few days after operation, particularly in cervical injuries. Nasopharyngeal, intratracheal, and bronchoscopic suction was employed as indicated for removal of excessive secretions. It was sometimes thought desirable to leave the patient flat on his back for a few hours postoperatively, to promote early sealing of the operative wound. Thereafter, he was to be moved at least every 2 hours, day and night. Unfortunately, this plan was not always feasible in active field and evacuation hospitals, though every effort was made to alter the position at some regular interval. Alert, cooperative patients could often be instructed to keep track of the time for movement themselves and to notify the attendants.

A change of position did not necessarily mean moving from back to abdomen every 2 hours, or even from side to side. The buttocks could be

raised alternately 2 or 3 inches with a small, soft pillow, a folded sheet, or towel. The legs could be shifted a few inches or rotated a few degrees. The legs were always kept separated by a pillow (fig. 17), and the points of pressure on this pillow were changed frequently. This type of adjustment of position could be carried out easily and safely by a single nurse or an aidman. For turning the patient from back to abdomen or from side to side, which was necessary at less frequent intervals, additional attendants were needed.

At all times, when the paralyzed patient lay on his back an effort was made to keep a pillow under his calves, so that his heels did not touch the bed (fig. 18). No attempt was made to hyperextend the spine except in fractures in the cervical region. In them, the head was allowed to fall back slightly by placing a small pillow or folded blanket under the shoulders to elevate them 2 to 3 inches (fig. 18 B). The prone position was well tolerated by patients with thoracic and lumbar injuries.

Care of the skin.—It has often been pointed out,¹¹ and it should be re-emphasized here, that bedsores are always pressure sores; they are not trophic disturbances of the skin. Every decubitus ulcer is preceded by a pressure area in which subsequent ischemic necrosis takes place. In spite of general knowledge of this fact, adequate care of the skin in spinal cord injuries proved one of the most difficult tasks the personnel of medical units in forward areas were called upon to perform.

The sequelae of pressure necrosis over bony prominences were, however, so distressing that all possible measures of prevention, no matter how laborious or time consuming, were attempted. Measures for the care of the skin of patients who had been operated on were usually initiated immediately after operation and were maintained as rigidly as the facilities and personnel permitted. An effort was made to give daily skin care to the area below the level of the lesion, with special attention devoted to the sacrum, trochanters, and heels. This entire area was massaged with alcohol, carefully dried, and powdered at least once daily and oftener if possible. Every attempt was made to keep the bed coverings dry at all times and as free from wrinkles as possible. Wet sheets or blankets demanded immediate replacement. All of these measures were feasible in hospitals in the forward areas except under the most unusual circumstances. The efficiency with which they were carried out determined, in large degree, the general status of the patient and the speed of convalescence when hospitals in rear echelons were reached.

Psychiatric care.—The depression experienced by patients with spinal cord injuries upon realization that paralysis might be permanent was often profound. Every reassurance that could be given, therefore, to sustain a

¹¹ (1) Davis, Loyal E.: *The Principles of Neurological Surgery*. Philadelphia: Lea & Febiger, 1946, 3d ed., pp. 321-322. (2) Raaf, J.: *Treatment of the Patient With Spinal Cord Injury*. *Am. J. Surg.* 67: 263-279, February 1945. (3) Munro, D.: *Thoracic and Lumbosacral Cord Injuries: A Study of 40 Cases*. *J.A.M.A.* 122: 1055-1063, 14 Aug. 1943. (4) Munro, D.: *Tidal Drainage and Cystometry in the Treatment of Sepsis Associated With Spinal-Cord Injuries*. *New England J. Med.* 229: 6-14, 1 July 1943.

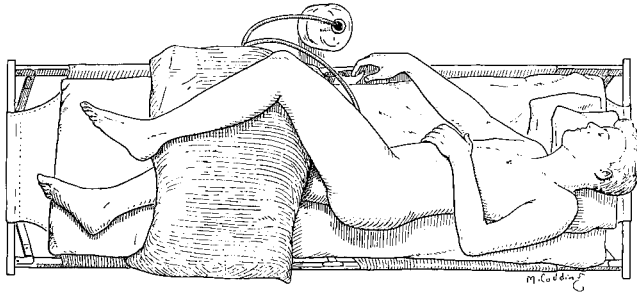

FIGURE 17.—Proper position of paralyzed patient with either thoracic or lumbar spinal wound. A soft pillow between the knees keeps the legs from touching one another. Another small pillow against the back allows frequent adjustment of the position of the trunk.

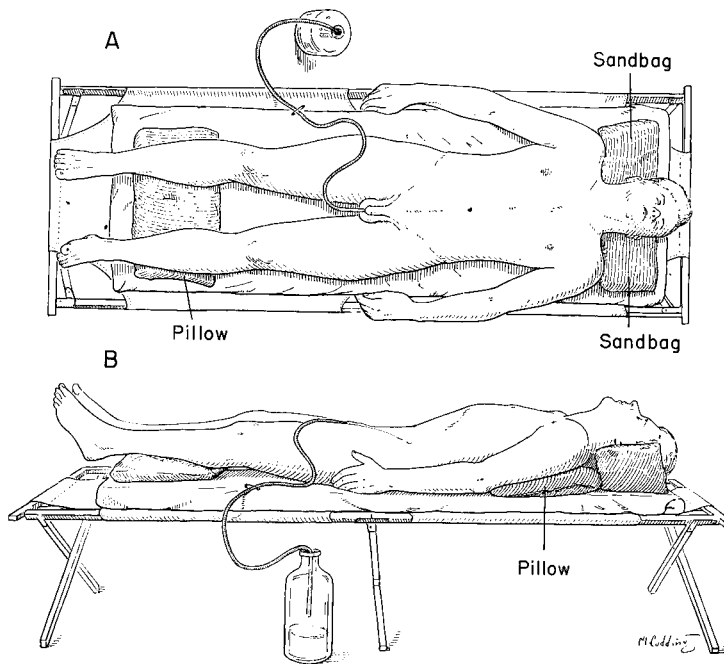

FIGURE 18.—Proper position for patient with compound fracture through low cervical or upper thoracic spine. A. View from above showing sandbags on both sides of head to prevent rotation and lateral deviation. Note that the indwelling catheter is connected to a tube which passes over the patient's thigh and is attached to the mattress with sufficient slack to prevent any tensions on the catheter. B. View from side. A broad pillow under the calves prevents the heels from touching the mattress, and a pillow under the shoulders allows the head to fall back in extension. Sandbags hold the head steady, as shown in view A.

casualty through the long period before any visible progress toward self-support was achieved proved highly desirable. An early, detailed explanation to the patient of the possibilities for adequate living with his disability often gave invaluable encouragement.

CARE OF THE BLADDER

Retention of urine, with a variable degree of overflow incontinence, was an immediate result of injury to the spinal cord at any level. The condition was not painful, because of the loss of sensation. It was of paramount importance, therefore, that these facts be remembered, so that management of the paralyzed bladder could be started at the earliest possible moment.

Usually, an indwelling urethral catheter was inserted under aseptic precautions as soon as feasible after the diagnosis of spinal cord injury had been made. It was important not to wait to see how much retention there would be, since, if marked distention of the bladder was once permitted, subsequent recovery of bladder tone and the development of automaticity were greatly delayed. Ideally, catheters should have been inserted at the first battalion aid or clearing station in which the patient was treated. Actually, circumstances did not often permit this, and urinary drainage was not usually instituted until after the patient's arrival at an evacuation or field hospital.

There are several ways of managing urinary retention in spinal cord injuries. All, however, were not practical in the forward areas.

1. Nonintervention, which simply means allowing the bladder to distend and overflow intermittently, is disastrous. Retrograde dilation and infection of the urinary tract invariably follow, and the constantly wet bedclothes quickly lead to breakdown of the sacral skin.

2. Repeated catheterization is a method of management which is mentioned only to be condemned. Under any circumstances, it is undesirable, and in the forward areas conditions did not permit the regularity and strict asepsis necessary to make this method at all feasible.

3. Manual compression, consisting of firm pressure on the bladder through the lower abdominal wall at 4-hour intervals, often produces satisfactory emptying of the bladder in the absence of obstruction. It obviates the danger of introducing infection. It must, however, be carried out with considerable care and with absolute regularity, and for these reasons it was impractical in the treatment of patients in forward areas and during long periods of transportation.

4. The use of an indwelling urethral catheter proved to be the most widely adaptable and most satisfactory method of bladder management. Foley type catheters were not available. A soft rubber catheter large enough to fit the urethra snugly (No. 16 to No. 22 F.) was inserted into the bladder under aseptic precautions and securely fastened to the penis with adhesive

strips. The indwelling catheter was attached to rubber tubing, which was always led out over, rather than under, the patient's thigh and into a constant drainage bottle at the side of the cot. The tubing was fastened to the side of the litter or cot in such a way as to permit turning the patient without tension on the catheter (fig. 18). Attention to the details of catheterization and to the arrangement for constant drainage was worthwhile and did much to prevent catheters from leaking and coming out unnecessarily.

Indwelling catheters were irrigated at least once daily and were changed weekly. Systemic chemotherapy was instituted in all patients in whom constant urethral drainage was employed, and a daily urine output of at least 1,000 cc. was maintained.

The studies of Munro¹² and many others have shown that early return of bladder tone and automaticity is best promoted by the use of tidal drainage. In units in forward areas, however, where equipment, time, and personnel were all limited and where transfers from one hospital to another were frequent and often unforeseen, tidal drainage proved entirely impractical. When nontransportable patients remained in the forward areas for 10 to 14 days, it was occasionally used, but, ordinarily, simple, constant urethral drainage was employed until the patients reached a general hospital in the rear.

5. Suprapubic cystostomy was preferred by many surgeons in the forward areas. This method was always indicated in the presence of a purulent urethritis or balanitis or in the presence of any injury or obstruction of the urethra itself. It was employed by most surgeons only in nontransportable cases and in other circumstances in which it was evident that it would be 10 to 14 days before the patient would reach an installation where tidal drainage could be established and continued satisfactorily. Suprapubic cystostomy was easily carried out under local anesthesia, or, in many of these cases, under virtually no anesthesia, through a short midline incision centered approximately halfway between the umbilicus and the pubis. It was important not to bring the catheter out too close to the pubis because of the danger of osteomyelitis. Perineal urethrostomy, in the hands of some urologic surgeons, proved to have some mechanical advantages over suprapubic cystostomy and was occasionally used in the forward areas.

In summary, the most satisfactory management of the paralyzed bladder consisted of the earliest possible insertion of a sufficiently large, well-secured urethral catheter, with maintenance of uninterrupted bladder drainage and the use of systemic chemotherapy until tidal drainage could be established at a fixed medical installation. Early suprapubic cystostomy was also satisfactory but was reserved by most surgeons for patients who presented local

¹² (1) Munro, D.: The Rehabilitation of Patients Totally Paralyzed Below the Waist, With Special Reference to Making Them Ambulatory and Capable of Earning Their Living. III. Tidal Drainage, Cystometry and Bladder Training. *New England J. Med.* 236: 223-235, 13 Feb. 1947. (2) Munro, D., and Hahn, J.: Tidal Drainage of the Urinary Bladder: A Preliminary Report of This Method of Treatment as Applied to "Cord Bladders" With a Description of Apparatus. *New England J. Med.* 212: 229-239, 7 Feb. 1935.

injury, obstruction, or infection and in whom constant urethral drainage was impossible or undesirable.

CARE OF THE GASTROINTESTINAL TRACT

Retention of feces as well as of urine was the usual immediate response to cord injury. For this reason, enemas were begun during the early post-operative period and were usually given every 2 days to prevent fecal impaction and incontinence. In lesions of the cervical and thoracic regions, atony of the bowel was frequently sufficient to produce distressing abdominal distention. Ileus was relieved by the administration of neostigmine bromide (Prostigmin bromide) and vasopressin (Pitressin) or by the insertion of a Miller-Abbott tube.

The use of the bedpan by paralyzed patients always introduced problems. It was necessary to raise the buttocks and thighs and the lower part of the back on pillows or folded blankets, so that the weight was never carried on the bedpan itself. Pressure on the skin over the sacrum could thus be avoided.

NUTRITION

It was found important, from the earliest possible moment, to devote special attention to the nutrition of patients with spinal cord injuries. The subsequent recovery of motor and sensory function, as well as the development of automaticity of the bladder and rectum, was shown to be markedly retarded in the presence of poor nutrition. The nutritional factor was also found to be extremely important in both the development and the healing of pressure sores. It was therefore essential to maintain an adequate caloric, protein, and vitamin intake from the beginning. Falling serum protein levels in the early period after injury were corrected by transfusions of plasma and whole blood. If the oral intake was not sufficient, it was supplemented by fluids and vitamins given parenterally, or by high-caloric, high-protein feedings by tube.

EVACUATION

In perhaps no other type of injury was the desirability of early evacuation of the patient to a fixed medical installation so great as in spinal cord lesions. Because the problems of nursing care in forward areas made satisfactory management so difficult, every effort was made to move these patients as soon as possible to hospitals staffed with adequate medical and nursing personnel and equipped with beds, mattresses, and facilities for tidal drainage of the bladder.

If no other complicating wound existed, casualties with spinal injuries could be evacuated within 3 to 5 days after laminectomy, or even earlier in most instances. An attempt was always made to expedite transportation to a neurosurgical center once evacuation had been decided upon.

Whether or not these patients had been operated on in a forward area, evacuation was undertaken only after certain preparations could be made, as follows:

1. The patient was placed on the litter on a mattress of folded blankets covered by a dry, tightly stretched sheet.
2. Arrangements were made as far as possible to continue chemotherapy without interruption en route.
3. A well-fitting, tightly secured urethral or suprapubic catheter was in place.
4. Arrangements were made for the maintenance of continuous urinary drainage and for adjustment of the patient's position at frequent intervals during transportation.

Unavoidable delays in transportation due to the exigencies of warfare occurred all too frequently and often contributed to the development of pressure sores which might otherwise have been avoided. It was, therefore, frequently a matter of individual judgment, depending upon the particular circumstances, to decide the optimum time for evacuation. If transportation facilities were poor but held promise of improvement, it was preferable to keep the patient in a forward unit and carry out surgical and supportive treatment there until rapid evacuation became available.

Because of its speed and comfort, air transportation proved the ideal method of evacuation of patients with these injuries of the spinal cord, who, therefore, were given the highest priority for movement by air. An effort was made to route them from forward units directly to the nearest airstrip for evacuation to a fixed neurosurgical installation in the rear.

FACTORS OF MORTALITY

Death in the acute stage of spinal cord injury occurred principally in two groups of casualties: (1) Those with transections of the cervical part of the cord, and (2) those with complicating injury to vital structures in the chest. In both of these groups, shock was profound and was often lethal in spite of treatment. The usual cause of death, however, was respiratory failure due to (1) interruption of the innervation to the muscles of respiration, or (2) insufficient aeration brought about by accumulation of secretions in the respiratory tree, by direct injury to the lungs themselves, or by massive hemothorax. Occasionally, patients with injuries of the thoracic and lumbar parts of the spinal cord succumbed although they might have survived but for associated injury to abdominal viscera. The actual early mortality rate from spinal cord injury itself is, therefore, difficult to determine.

No attempt will be made here to report complete statistics, but the results obtained in the early treatment of these wounds can be illustrated in a general way. In 482 patients with spinal cord injury who reached

field and evacuation hospitals of the First U.S. Army alive during a 9-month period, the overall mortality was 14.5 percent. This figure is almost identical with that observed at two individual evacuation hospitals; 93 patients were treated at the 45th Evacuation Hospital, with a case fatality rate of 16.1 percent, and 85 cases at the 128th Evacuation Hospital, with a case fatality rate of 14.1 percent.

Accurate conclusions regarding postoperative case fatality rates in the acute stage are even more difficult to ascertain because of the wide discrepancies in individual surgeons' indications for laminectomy and because of the lack of uniformity in periods of postoperative observation in forward hospitals. It was amply proved, however, that early laminectomy itself was not a hazardous procedure in competent hands when the proper neurosurgical equipment and supportive therapy were available. Postoperative meningitis without a persistent spinal fluid fistula was extremely uncommon and was usually readily controlled by systemic and intrathecal penicillin therapy. As in cord lesions that were not operated upon, early fatalities were usually caused by pulmonary edema or occurred in the presence of severe associated injuries of thoracic or abdominal viscera.

The figures in table 3, reported by individual surgeons, concern postoperative observations varying from 2 or 3 days up to 2 weeks, but it is believed that they are of general significance:

TABLE 3.—*Specimen case fatality rates in surgery of spinal cord injuries*

Surgeon	Surgical cases	Case fatality rate
Tinsley	22	4.5
Haynes	76	7.9
Matson	33	6.1
Pool	35	11.4

CHAPTER VI

Urologic Aspects of Spinal Cord Injuries

George C. Prather, M.D.

As a result of the cooperation of specialists in many fields, the outlook for patients who sustained spinal cord injuries in World War II was greatly improved over that of patients with similar injuries in World War I. This chapter is concerned with the role of the urologic surgeon in that cooperative endeavor. The literature on the subject before 1941 is included, since most of the diagnostic and therapeutic procedures employed in Army hospitals had previously been tested in civilian clinics. World War II simply supplied the opportunity for their trial on a mass scale.

THE STATUS OF THE BLADDER AFTER INJURY OF THE SPINAL CORD

Historical Note

Severe injury of the spinal cord produces a profound effect on bladder activity. Recorded observations in man and in animals show that, in the absence of complications, time has an important, though variable, effect on bladder physiology. The immediate disturbances and subsequent changes in the bladder may be described as stages in the natural process of recovery. Knowledge of these phenomena is essential for a proper interpretation of the status of the bladder at a given time, as well as for the formulation of opinions regarding the eventual results and the evaluation of various forms of treatment.

Even though it was known that, in animals, bladder activity could be resumed after spinal cord injury, Kidd,¹ in 1919, stated that before World War I patients seldom recovered from paraplegia; that a bladder, once paralyzed, was not likely to recover; and that an automatic bladder was a rarity. He emphasized the importance of the demonstration by Head and Riddoch² of the possibility of the establishment of an automatic bladder in battle casualties.

¹ Kidd, F.: The Treatment of the Bladder in Gunshot Injuries of the Spinal Cord. Brit. M.J. 1: 397-399, 5 Apr. 1919.

² Head, H., and Riddoch, G.: The Automatic Bladder, Excessive Sweating and Some Other Reflex Conditions, in Gross Injuries of the Spinal Cord. Brain 40: 188-263, November 1917.

Holmes,³ in 1933, in a study by cystometric methods of the recovery of bladder activity after spinal cord injury identified three stages which merged into each other. Munro,⁴ in 1936, recognized three stages in the recovery process if the cord transection was above the sacral segment; when the lesion was due to hematomyelia or edema at any level, he thought that four stages could be recognized.

PROGRESS OF RECOVERY

Observations by cystometric methods in World War II pointed to three stages of recovery, though the cystometric picture in the third stage depended upon whether or not transection was partial or complete. These stages are best conceived of as recognizable but merging phases of a gradual and continuous development. The duration of each stage varied in the patients studied in World War II and was also subject to fluctuation according to the presence or absence of complications, not only in the urinary tract but in other parts of the body.

Spinal Shock

Before the three stages in the natural process of recovery are discussed, it is necessary to consider the phenomenon which, in 1843, was termed "spinal shock" by Marshall Hall (cited by Fulton and McCouch).⁵ This term has continued in good usage to the present time. Spinal shock, which dominates the picture in the first stage of recovery, refers to the immediate but usually temporary suppression of all reflexes caudal to the injured segment. It has been defined by Munro as "that condition which when caused by spinal injury of any type produces suppression or alteration of segmental reflex activity below the level of the cord injury."

Spinal shock occurs in all vertebrates, its intensity varying with cerebral development. This is consistent with observations that the severity or duration of the phenomenon, or both, are progressively manifested in the cat, dog, monkey, chimpanzee, and man. Fulton and his associates⁶ demonstrated that, in the cat, spinal shock does not occur unless the ventral quadrant of the spinal cord is sectioned. Later, Fulton and McCouch pointed out that, in man, section of the corticospinal tract leads to spinal shock. They further suggested that the present concept of spinal shock indicates a suppression of reflexes caused by sudden withdrawal of continuous excitation which normally occurs from suprasegmental levels via the descending pathways.

³ Holmes, G.: Observations on the Paralyzed Bladder. *Brain* 56: 383-396, December 1933.

⁴ Munro, D.: The Activity of the Urinary Bladder as Measured by a New and Inexpensive Cystometer. *New England J. Med.* 214: 617-624, 26 Mar. 1936.

⁵ Fulton, J. F., and McCouch, G. P.: The Relation of the Motor Area of Primates to Hyporeflexia ('Spinal Shock') of Spinal Transection. *J. Nerv. & Ment. Dis.* 86: 125-146, August 1937.

⁶ Fulton, J. F., Liddell, E. G. T., and Rioch, D. M.: The Influence of Experimental Lesions of the Spinal Cord Upon the Knee Jerk. I. Acute Lesions. *Brain* 53: 311-326, October 1930.

First Stage of Recovery

After injury of the spinal cord, the bladder, as a reflex organ, is immediately affected and dominated by spinal shock, as shown by atonicity of the bladder wall and loss of reflex contractions of the detrusor. The bladder thus becomes distended to large capacity, reaching to, or above, the umbilicus. Overflow incontinence, which may occur after a period of 24 to 48 hours, is the only type of urination that can be expected. Cystometric studies during this stage show a bladder of large capacity and low intravesical pressure, without evidence of reflex detrusor activity (the so-called atonic neurogenic bladder). Holmes found no pressure recorded until 4 to 8 oz. of fluid had been introduced into the bladder. The pressure then rose slowly, reaching a level of 8 to 10 cm. H₂O when 20 oz. had accumulated. The pressure curve repeated itself when the bladder was emptied. Cystitis caused no change in the cystometric record, and the findings were the same for injury at all levels of the cord and for injuries of the cauda equina. In other words, the bladder, at this stage, presented only the property of elasticity.

Holmes stated that the first stage of recovery lasted from a period of days to one of weeks. According to Thomson-Walker,⁷ it may last from 24 hours to 18 months.

Second Stage of Recovery

After a variable period of time, a return of mild reflex activity caudal to the injured segment usually becomes evident and produces changes in the activity of the vesical musculature. Progression from the first to the second stage occurs gradually but can be demonstrated by cystometric study. The bladder now has a smaller capacity, intravesical pressure is increased, and the curve rises more rapidly. Although reflex contractions of the bladder can be observed, they are of insufficient strength or duration to produce efficient emptying. According to Munro,⁸ these contractions are due to a reflex arc that lies wholly within the bladder wall. The term "autonomous cord bladder" is used to describe the status of the bladder at this stage. Several observers⁹ believe that the autonomous bladder may represent the final stage of recovery in cases in which there has been complete transection of the cord at the level of the sacral segments or cauda equina.

⁷ Thomson-Walker, J.: The Treatment of the Bladder in Spinal Injuries in War. *Brit. J. Urol.* 9: 217-230, September 1937.

⁸ Munro, D.: Treatment of the Urinary Bladder in Cases With Injury of the Spinal Cord. *Am. J. Surg.* 38: 120-136, October 1937.

⁹ (1) Lewis, L. G.: Treatment of the Neurogenic Bladder After Acute Spinal Injury. *S. Clin. North America* 23: 1505-1525, December 1943. (2) Munro, D.: The Cord Bladder—Its Definition, Treatment and Prognosis When Associated With Spinal Cord Injuries. *New England J. Med.* 215: 766-777, 22 Oct. 1936. (3) Nesbit, R. M., and Gordon, W. G.: The Management of the Urinary Bladder in Traumatic Lesions of the Spinal Cord and Cauda Equina. *Surg. Gynec. & Obst.* 72(2A): 328-331, February 1941.

The clinical manifestation of the second stage of recovery is overflow incontinence. The amount of residual urine is smaller than in the first stage, perhaps because bladder capacity is not so great.

Third Stage of Recovery

Further recovery of the bladder beyond the second stage depends upon several factors, including the extent of the injury of the spinal cord, the level of the injury, the severity of bladder infection, and the general condition of the patient. The type of bladder to be reasonably hoped for in the final stage of the recovery process depends upon whether transection of the spinal cord has been partial or complete.

Complete transection of the cord.—Patients with complete transection of the cord show complete functional interruption of the cord at a given level for a long period of time. In some cases, this is demonstrable when the cord is visualized at operation. If laminectomy has not been done, patients are regarded as falling within this category if they show no evidence of voluntary motor power or return of sensation below the level of the injury during a period of at least 6 months after injury.

It is expected that the bladder of the patient with complete transection of the cord will progress to a final stage in which periodic, involuntary, forceful, and efficient micturition is characteristic. The patient has no voluntary control over the periodic reflex voiding, but during the 1-hour to 4-hour intervals between voidings, there is no leakage of urine. The patient with this type of bladder becomes familiar with his individual time schedule and learns to govern his activities accordingly. It was observed in patients in World War II, though it was never explained, that the intervals between voidings were frequently much longer when the patient was in the sitting position than when he was recumbent in bed. Bladder capacity in this final stage was found to vary between 150 and 400 cc. and residual urine from 30 to 90 cc.

It was observed in Army paraplegic centers that emptying contractions of the bladder usually created an intravesical pressure of 70 cm. H₂O or more. Holmes found oscillations of bladder pressure independent of reflex contractions of the legs and did not regard bladder activity as part of a mass reflex. Head and Riddoch, on the other hand, had found that peripheral stimuli often initiated automatic reflex evacuation of the bladder except in cases of complete transection of the cauda equina.

The term "automatic reflex bladder" is used to describe the type of vesical activity achieved by patients in the third stage of recovery. It is the normal end of the path of recovery in patients who have had complete transection of the spinal cord. Most with complete transection can be expected to progress to this stage, although a few appear to remain in the first or second stage; even when the nerve lesion is above T₁₀, bladder in-

fection is minimal, and the general condition is excellent. Limited recovery is usually associated with flaccid paralysis of the lower extremities. The cause of failure of progression to an automatic type of bladder is not clear, but it is possible that lack of vascularity in the distal segment of the spinal cord has led to necrosis and that insufficient tissue remains to permit a suitable reflex arc.

Partial transection of the cord.—Patients with partial transection of the spinal cord show some evidence of voluntary motor power and sensory appreciation below the level of the lesion, although it may not be evident for several months after injury. The expectation is that patients in this category will progress to a third or final stage of bladder recovery characterized by voluntary micturition sufficient to produce efficient emptying of the bladder. Control is voluntary, although during the act of voiding it may be necessary to use manual pressure over the lower abdomen, or there may be straining and diminished sensation over the bladder region. The organ under these circumstances can be termed a “voluntary neurogenic bladder.” Bladder capacity is within normal limits, and residual urine varies in amounts.

Although the terms “complete transection” and “incomplete transection” have been emphasized because of their importance in predicting eventual outcome and evaluating the results of treatment, it is often difficult to state with assurance immediately after injury whether or not the lesion is complete. During spinal shock, no reliable data can be secured about the degree of nerve injury.¹⁰

Level of injury.—The level of injury in the cord may have some bearing on the degree of recovery. Denny-Brown¹¹ and Head¹² recorded cases of complete transection at the level of the conus or cauda equina in which an automatic reflex type of bladder developed, but Lewis and Riches pointed out that patients with complete lesions above the lumbar segments develop an automatic type of voiding much more consistently than those whose lesions are below that level.

Other factors.—Other factors of importance in the recovery process include a positive nitrogen balance; freedom from toxic and febrile states; absence of decubitus ulcers; and absence of gross infection of the bladder wall, this being essential for recovery of the organ, since infection of the muscle layers followed by fibrosis would naturally militate against satisfactory bladder function. Experience with paraplegic patients in World War II confirmed the importance of all these statements.

¹⁰ Riches, E. W.: Methods and Results of Treatment in Cases of Paralysis of Bladder Following Spinal Injury. *Brit. J. Surg.* 31: 135-146, October 1943.

¹¹ Denny-Brown, D. E.: Nervous Disturbances of the Vesical Sphincter. *New England J. Med.* 215: 647-652, 8 Oct. 1936.

¹² Head, Henry: *Studies in Neurology*. London: Henry Frowde, Hodder & Stoughton Ltd., 1920, vol. II, passim.

METHODS OF EXAMINATION OF THE BLADDER

Study of the bladder and of the region of the bladder neck is essential in every case to secure comparative data and to determine the method of treatment necessary for optimum results. Not all methods of examination are applicable in every case, nor, as was demonstrated in World War II, are they all essential in the days or weeks immediately following injury, but they should be used selectively, according to the needs of the individual case. The most important of these methods are urinalysis, determination of residual urine, cystometry, cystoscopy, and cystography.

Urinalysis

Examination of the urine in paraplegic subjects contributed the greatest amount to knowledge of the condition of the bladder. Immediate examination of a freshly obtained specimen was stressed, and it was recommended that, at intervals, the specimen be examined by the urologist himself, personal correlation of microscopic findings and clinical picture being preferable to the usual formal data entered on a laboratory report.

The centrifuged urine sediment, when carefully examined under the high-powered dry lens (or oil immersion if the specimen was stained), provided an approximate indication of the degree of infection in the bladder, though it did not necessarily indicate the state of the bladder mucosa. During an acute urinary infection, with pyuria, the bladder mucosa was always infected and red and perhaps showed edema or hemorrhagic areas. In patients with mild, chronic infection, there was usually no change from normal, but when bacteria were present in bladder urine, potential cystitis and pyelitis were also present.

Badal, Munro, and Lamb,¹³ in a careful cultural study of urines of patients on tidal drainage, concluded that bacteria are always present in the bladder 72 hours after the introduction of an indwelling catheter. The most common organisms found in their studies were *Proteus vulgaris*, *Escherichia coli*, and alpha hemolytic streptococci. Prather's studies of routine cultures taken from the distal ends of urethral catheters or suprapubic tubes after several months of drainage showed staphylococci, *Pseudomonas aeruginosa*, *P. vulgaris*, and *Esch. coli* as the most common urinary inhabitants. Predominating organisms changed from week to week.

There is no doubt that any kind of tube kept in the bladder for more than 40 hours acts as a foreign body and gives rise to a foreign-body reaction which provides a locus for bacterial growth. Bacterial growth ensues, as in other parts of the body, but, also as in other parts of the body, if the region is properly drained and cleansed and if adequate body resistance is maintained, clinical evidence of infection does not develop. A positive

¹³ Badal, D., Munro, D., and Lamb, M. E.: Clinical Significance of Bacteriuria in Patients With Spinal-Cord Injuries. *New England J. Med.* 230: 688-693, 8 June 1944.

urine culture with any type of bladder drainage therefore indicates potential, but not necessarily actual, clinical disease.

Cultures were also always desirable for another reason, to determine proper medication should clinical evidence of sepsis occur.

David's¹⁴ experimental studies can be correlated with clinical experience. After injection of *Bacillus coli* into the bladders of normal dogs, he found that organisms remained in the urine for some time but that no histologic evidence of cystitis or pyelitis appeared. If an animal had a bladder residual, however, the introduction of bacteria into the bladder caused ulcerative cystitis and renal infection. After section of the lower dorsal spine of the experimental animal, infection in the wound in the back was followed by bladder infection with the same organisms.

Cystometry

Cystometry is useful to determine bladder tone (the relation of the volume of bladder content to intracystic pressure), the presence or absence of reflex contractions of bladder muscle, bladder capacity, maximum voluntary pressure, and sensation to bladder distention. Although various forms of instruments for cystometry are available, a simple model, which is easily disassembled and sterilized, is entirely adequate. The model shown (fig. 19) has no automatic recording device. More can always be learned about the individual patient by close observation while the examination is in progress than can be gathered from a casual survey of a completed record. In some models used for tidal drainage, cystometric observations can be made without additional equipment.

Two features are important in any apparatus used for cystometry. First, a water (or very sensitive aneroid) manometer is required to measure small changes in intracystic pressure. In addition, a constant drip method of filling the bladder during the procedure is to be preferred to the older method of introducing 25-cc. to 50-cc. increments of fluid into the bladder at intervals. By the constant drip method, the manometer is not shut off, no reflex activity is missed, and there is no confusion or delay while one awaits the downward step-ladder changes in pressure so common immediately following the sudden introduction of larger amounts of fluid.

Normal bladder activity.—There are some differences of opinion concerning normal bladder activity as demonstrated by cystometric studies. Munro described three types, as follows:

1. Spaced, emptyinglike contractions occurred throughout the experiment.
2. Emptying contractions occurred toward the end of a 400-cc. fill in the form of unspaced tetanic contractions.
3. No emptying contractions occurred until over 400 cc. of fluid had been introduced into the bladder.

¹⁴David, V. C.: The Management of the Urinary Tract of Paraplegic Patients. J.A.M.A. 75: 494-497, 19 Feb. 1921.

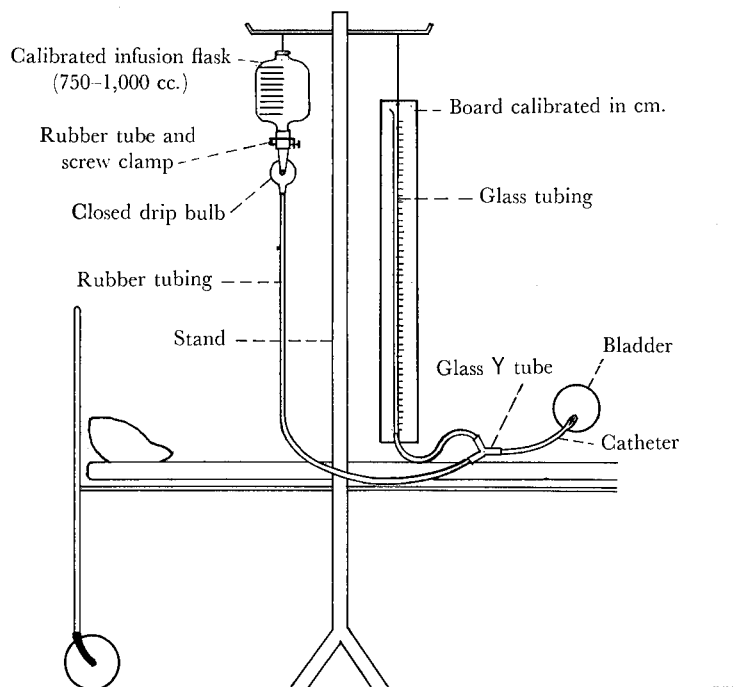

FIGURE 19.—Simple cystometer using principle of constant drip filling of bladder and indication of intravesical pressure in centimeters H_2O . The set consists of an infusion bottle, rubber tubing, straight glass tubing, and board calibrated in centimeters. It is autoclaved between individual studies.

Simeone and Lampson¹⁵ reported that cystometric curves observed in their studies of normal individuals could be divided into an initial rise, a relatively flat area, and a final sharp rise. Spontaneous bladder contractions were practically never seen until a steep rise in pressure had occurred. Muschat, Carp, and Charny¹⁶ were of the opinion that too much stress was ordinarily laid on the pressure curve and emphasized, instead, the composite picture consisting of (1) the first desire to void, (2) the pressure curve, which gradually rose, and (3) the maximal voluntary pressure of 60–80 mm. Hg. Examples of pressure curves in normal individuals¹⁷ are shown in figures 20 and 21.

Cystometric findings after injury.—Cystometric findings are immediately altered after injury of the spinal cord. During the period of spinal shock, in the first stage of recovery, with associated loss of reflexes below the level of injury, the pressure curve is flat and low, bladder capacity is

¹⁵ Simeone, F. A., and Lampson, R. S.: Cystometric Study of the Function of the Urinary Bladder. *Ann. Surg.* 106: 413–422, September 1937.

¹⁶ Muschat, M., Carp, J., and Charny, C. W.: The Normal Cystometrogram. *J. Urol.* 37: 718–720, May 1937.

¹⁷ Watkins, K. H.: Clinical Value of Bladder Pressure Estimations. *Brit. J. Urol.* 6: 104–118, June 1934.

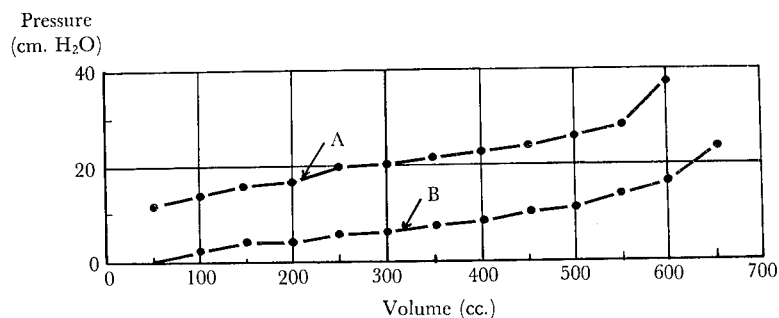

FIGURE 20.—Cystometric curves in centimeters H₂O of normal bladder at rest. Curve A represents the highest, and curve B the lowest, curve in a series of examinations. First sensation is at 100 cc. in curve A and at 150 cc. in curve B. (From Watkins.)

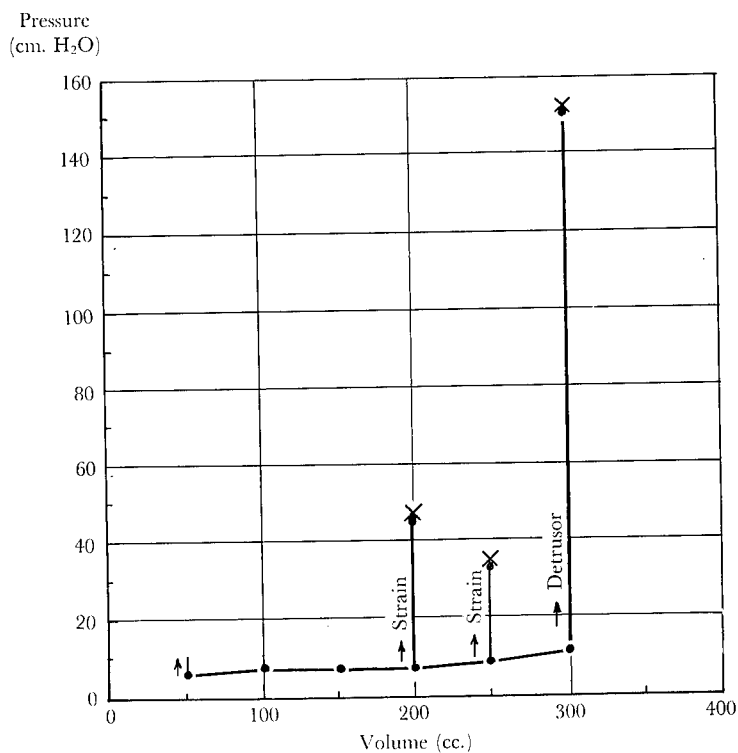

FIGURE 21.—Cystometric curve. Pressures recorded on bladder with normal innervation. The vertical lines rising from the curve at rest indicate the result of attempted urination. The first three attempts had very little effect. A marked increase of pressure resulted at the next two efforts, after the man was requested to strain as hard as possible with his abdominal muscles. At the last attempt at urination, the micturition reflex was released, and the high pressure which results from contraction of the detrusor muscle is shown. First sensation was noticed at 250 cc. (From Watkins.)

increased to 500 to 600 cc. or more, no reflex contractions are evident, and the sensation of distention is lacking except when the lesions are low in the spinal cord; then, painful sensations may be felt in the lower part of the abdomen. An example of a typical cystometric chart in this stage (atonic neurogenic bladder) is shown in figure 22.

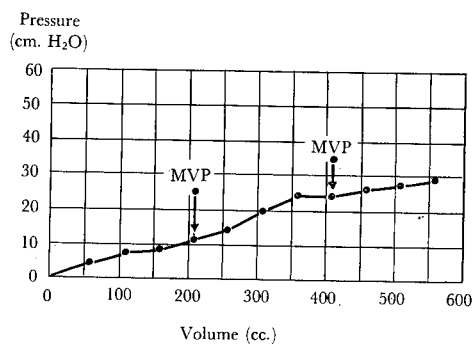
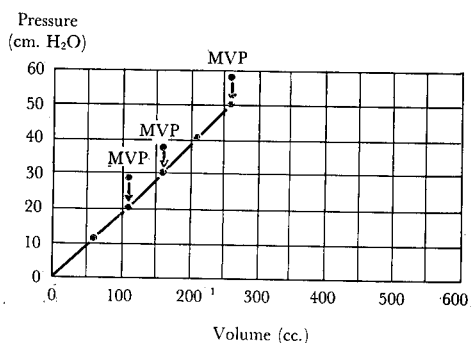

FIGURE 22.—Cystometrogram showing atonic bladder at first stage of recovery following severe spinal cord injury. In a few cases, this stage may be permanent.



¹ Lower abdominal pain.

FIGURE 23.—Cystometrogram illustrating second stage of recovery in patient with complete transection of middorsal portion of spinal cord. The rise in pressure is rather steep, but there are no reflex voiding contractions. The lesion is too high to permit more than a 10-cm. rise by maximum voluntary pressure.

As the bladder begins to show recovery from spinal shock and the second stage develops (autonomous cord bladder), the cystometric chart reflects certain changes, including increased initial tonus; a fairly steep pressure curve; a capacity limited to that of a normal bladder; minor rhythmic detrusor contractions, seldom greater than 10 cm. H₂O and insufficient to empty the bladder; lack of definite desire to void; and, in some patients, a feeling of lower abdominal discomfort when the bladder is full. A cystometrogram taken at this stage is shown in figure 23.

Cystometric findings in the third stage of recovery depend upon whether or not transection has been complete. Instances of complete transection, when the bladder is of the reflex or automatic type, the following findings are characteristic: normal to increased initial tonus; variable pressure curve; a capacity between 150 and 400 cc.; forceful reflex detrusor contractions, with urination when capacity has been reached; no sensation of bladder distention; and, frequently, variable flushing or sweating reactions in the upper part of the body when the bladder reflex is about to act. The cystometric chart of this type of patient is shown in figure 24.

When transection of the cord is partial, urination is voluntarily controlled and cystometric findings may be very close to normal, especially if the lesion is in the upper part of the cord (fig. 25). Figures 26 and 27 show studies on patients with partial transection of the cauda equina.

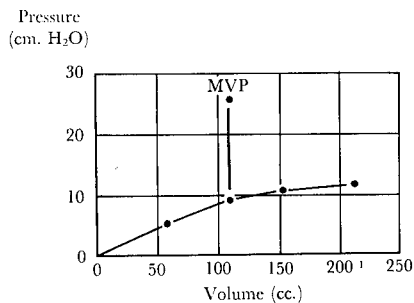

¹Leakage around catheter.

FIGURE 24.—Cystometrograph illustrating third or final stage of recovery in patient with complete transection of upper thoracic portion of spinal cord. Reflex contractions occur periodically during constant filling, but they are insufficient to produce voiding until 150 to 200 cc. has accumulated in the bladder. The patient has an automatic reflex type of urination at fairly regular intervals with no leakage of urine between voidings.

The data just listed were collected routinely on all military casualties in World War II. In addition, Mullenix¹⁸ advocated that, in traumatic paraplegias, there should be determination of active or maximum bladder pressure routinely throughout the entire process of bladder filling. This was done in numerous instances and gave interesting information.

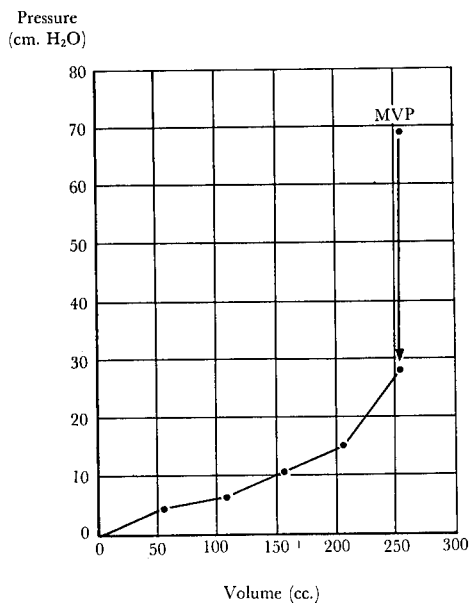

¹Desire to void.

FIGURE 25.—Cystometrograph in patient with partial transection of cervical portion of spinal cord. Voiding is now voluntary, with perfect control. The cystometric data, which are essentially normal, represent the typical third or final stage of recovery in partial transections in the upper segments of the spinal cord.

¹⁸ Mullenix, R. B.: Cystometry in the Study of the Traumatic Neurogenic Bladder. *J. Urol.* 55: 470-482, May 1946.

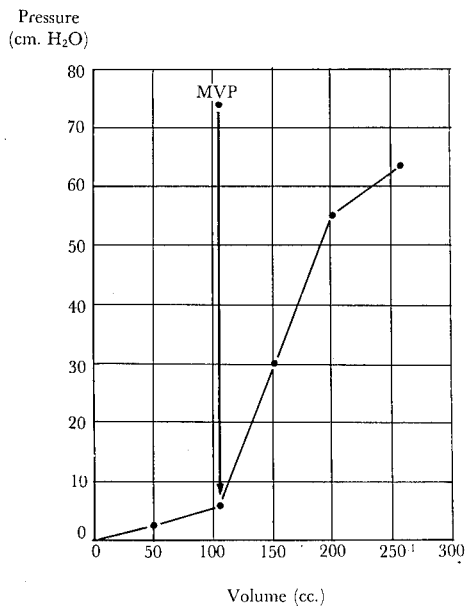
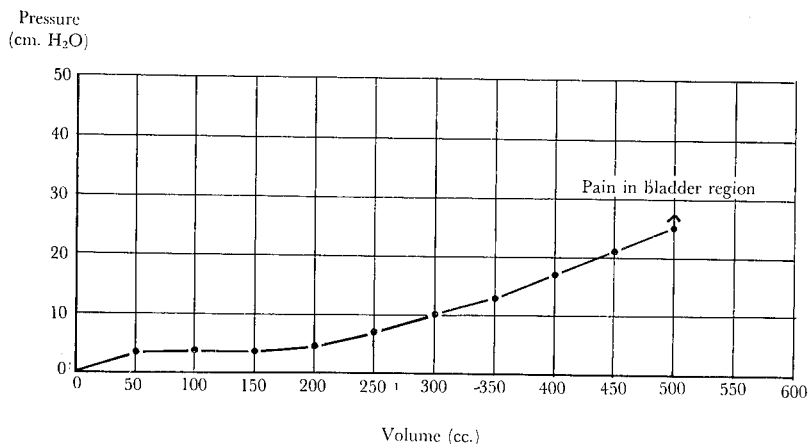

FIGURE 26.—Cystometrogram in patient with partial transection of cauda equina. Recovery to the third stage of voluntary voiding has been accomplished. Because the nerve lesion is low, maximum voluntary pressure is essentially normal.

¹ Leakage around catheter.



¹ Desire to void.

FIGURE 27.—Cystometrogram in patient with partial transection of cauda equina. Recovery is not yet complete. The pressure curve is somewhat flattened, but, soon after this examination, the patient developed voluntary voiding, which had to be supplemented by abdominal pressure.

Mullenix used the term "expulsive force" for the difference between voluntary pressure and the usual passive values recorded during filling. He believed this factor important in any prognosis of the ability to void. Prather's interpretation of maximum voluntary pressure is that it reflects either paralysis or integrity of muscles of the abdominal wall, its value being primarily dependent on the level (and perhaps the extent) of the spinal lesion. In injuries of the conus or cauda equina, with no paralysis of the abdominal muscles, the voluntary contraction of these muscles raises intravesical pressure and may, to advantage, augment the reflex contractions of the detrusor. In injuries of the upper part of the spinal cord, since the abdominal muscles cannot be voluntarily contracted, there is little difference between the passive pressure and the maximum voluntary pressure. Observations in military casualties bore out these observations.

Cystometric responses vary, and changes from one stage of recovery to another do not necessarily occur rapidly. Repeated examinations are frequently required to obtain an accurate impression of the functional capacity of the bladder muscle. Effectiveness in voiding may also be influenced by conditions in the region of the bladder neck and the urethra.

It was the opinion of all concerned with the management of battle-incurred paraplegias and other traumatic types in World War II that cystometric studies were an integral part of the complete study of bladder physiology.

Cystoscopy

Cystoscopy was not recommended routinely as part of the examination of paraplegic patients in the early period of their disability. Used selectively, and with due care to avoid trauma, it supplemented other examinations and at times was invaluable in disclosing and dealing with bladder stones and in explaining abnormal roentgenologic findings. Unless it was employed for special studies, it was used only during the latter part of the recovery period, to identify changes in the bladder neck which needed correction in order to improve bladder function. Its use was strictly limited to medical officers who were experienced with it; injuries of the lower urinary tract at the hands of untrained cystoscopists could readily occur because of absence of normal sensation in paraplegic patients.

The cystoscopic picture in the paraplegic patient varied with the stage of recovery. During the first (atonic) stage, the mucosa was usually smooth, with fine trabeculation. During the second stage, moderately heavy trabeculation was frequently found. During the third stage, patients with complete transection who had developed an automatic bladder showed moderate to heavy trabeculation. Patients with partial transection who were voiding effectively with voluntary control showed normal mucosa if the spinal lesion was high and coarse trabeculation if the injury involved the cauda equina.

Trabeculation, which indicates a thickened bladder wall, could ap-

parently not be explained entirely by the effort of the bladder muscle to overcome urethral or vesical neck obstruction as it was observed in patients who were still on drainage. Hargrave,¹⁹ in 1852, had noted a similar finding at autopsy in a patient who had been treated by intermittent catheterization.

No abnormality was observed in the appearance of the ureteral orifices except for occasional edema, presumably caused by contact with the catheter or with a suprapubic tube placed too low in the bladder.

Although it is generally believed that the bladder neck, prostatic urethra, external sphincter, and membranous urethra relax or open after contraction of the detrusor muscle has begun, these regions are closely linked to the physiology of the bladder. In a complete study of bladder action following spinal cord injury, the region of the bladder neck deserves study along with the bladder. Information concerning it was obtained by cystoscopy with the Foroblique lens system or by urethrocystography. Sphincterometry as developed by Simons²⁰ was not used in paraplegic centers, though its possibilities have since been expanded.

Cystoscopic and cystographic observations had been made by Uhle,²¹ in 1913, to study methods of bladder closure. Burns,²² in 1917, had made similar studies in a series of tabetic patients; but Plaggemeyer,²³ in 1921, seems to have been the first to make cystoscopic studies in patients with spinal cord injuries. He described complete relaxation of the prostatic urethra and bladder neck, elevation of the trigone in some cases, and atrophy in others. Cumming,²⁴ in 1922, made cystoscopic observations in paraplegics and described a relaxed bladder neck and a normal or hypertonic external sphincter. In further studies,²⁵ he demonstrated dilatation of the bladder neck during the stage of overflow incontinence and concluded that the internal sphincter is regularly dilated and presumably inactive soon after the onset of paralysis but regains tone in periods of recovery.

Prather's observations on patients with spinal cord injuries in Army paraplegic centers, which were made through a No. 20 F. panendoscope with Foroblique vision, may be summarized as follows:

1. The prostatic urethra and bladder neck were definitely relaxed and dilated in patients with complete transection of the spinal cord in the upper and middle thoracic segments who had flaccid paralysis below the

¹⁹ Hargrave, Professor (reported by Mr. Arthur H. Taylor): Fracture of the Spine—Hypertrophy of the Bladder Caused by Long-Continued Disease of the Spinal Cord. Dublin M. Press 27: 161-163, 1852.

²⁰ Simons, I.: Advances in the Field of Cystometry Due to Clinical Studies With the Sphincterometer; Studies in Bladder Function; Preliminary Report. J. Urol. 36: 88-97, July 1936.

²¹ Uhle, A. A.: Clinical Observations Upon the Mechanism of Bladder Closure. Tr. Am. A. Genito-Urin. Surgeons 8: 303-313, 1913.

²² Burns, J. E.: The Bladder Changes Due to Lesions of the Central Nervous System; Their Description and Treatment. Surg. Gynec. & Obst. 24: 659-668, June 1917.

²³ Plaggemeyer, H. W.: Final Report on Fractures of the Spine in Relation to Changes in Kidney and Bladder Function. J. Urol. 6: 183-193, September 1921.

²⁴ Cumming, R. E.: Shell Fracture of the Spine and Changes in Kidney and Bladder Function; Further Observations. J.A.M.A. 78: 335-339, 4 Feb. 1922.

²⁵ Cumming, R. E.: Structural and Functional Changes in the Urinary Tract Following Focal Cord Lesions. J.A.M.A. 99: 1998-2004, 10 Dec. 1932.

level of the lesion and who had, as yet, failed to develop any sign of reflex activity of the bladder wall.

2. The bladder neck appeared normal for the age group in the majority of patients with complete transection of the cord in the upper or middle thoracic segments whose bladders had recovered to the third (final) phase and who were voiding periodically (automatic reflex bladder). In others in this group, there appeared to be slight dilatation of the prostatic urethra.

3. Patients with complete transection at D₁₂ or below invariably showed moderate to considerable relaxation of the bladder neck and prostatic urethra.

4. Most patients with partial transection at these lower levels revealed slight to moderate dilatation in the same region.

5. When partial transection had occurred in the higher segments of the cord, the bladder neck usually appeared normal.

Bumpus, Nourse, and Thompson²⁶ reported various degrees of vesical neck relaxation after cystoscopic examination. In some patients, they found constriction in the region of the internal urethral orifice, so that the bladder and prostatic urethra had an hourglass appearance. In other cases, they observed a bar type of deformity.²⁷

Cystography

Cystography, which permits indirect observation of the bladder, was used to determine the general shape of the organ, the presence and size of diverticula, spasticity, and approximate capacity. Roentgenographic studies were made after the injection of sterile sodium iodide (3 to 4 percent) or Skiodan (8 to 10 percent) through a catheter or suprapubic tube. Films of the bladder region about 45 minutes after injection of a medium for intravenous pyelography usually provided satisfactory data if the drainage tube in the bladder was clamped off during examination.

During the first stage of recovery (the period of spinal shock), cystograms showed a large, smooth-walled bladder, which, if filled to capacity, would occupy the whole bony pelvis (fig. 28). A similar picture was likely to be found in severe lesions of the cauda equina. In the second stage of recovery, cystograms showed irregularities in the periphery of a bladder of normal size, caused by trabeculations. In the third stage, the cystogram of the distended automatic bladder frequently revealed a rounded appearance with an irregular border consistent with trabeculation. During the third stage, in patients with partial transection, the cystogram appeared normal except in lesions of the cauda equina, in which the bladder appeared slightly dilated, with a slightly irregular margin.

²⁶ Bumpus, H. C., Jr., Nourse, M. H., and Thompson, G. J.: Urological Complications in Injury of the Spinal Cord. *J.A.M.A.* 133: 366-369, 8 Feb. 1947.

²⁷ Numerous postwar studies in Veterans' Administration hospitals have produced extensive data on cystoscopic findings in paraplegic subjects.

Reflux up into one or both ureters was occasionally observed when the cystographic medium had been introduced through the urethral catheter, but this was an infrequent finding in the paraplegic patient, at least during the early months after injury. It was more common after a considerable period of time had elapsed (fig. 29). Reflux was assumed to be the result of an inflammatory change involving the ureteral orifice rather than a direct effect of the nerve lesion.

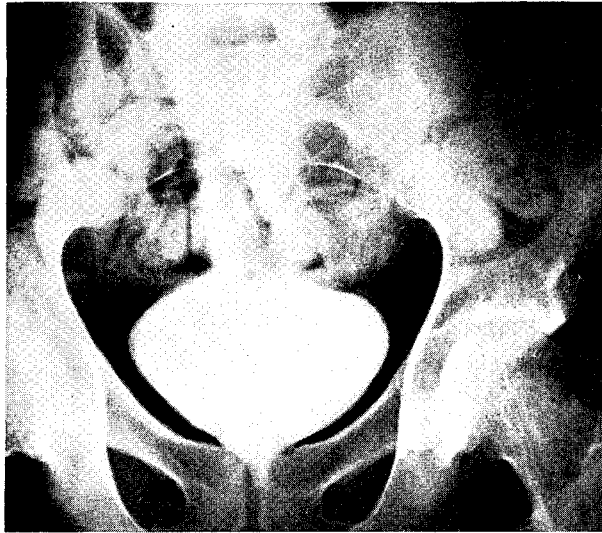

FIGURE 28.—Cystogram through suprapubic tube in patient with complete transection of dorsal portion of spinal cord in first stage of recovery. The bladder is atonic, and the bladder neck is dilated.

Cystourethrography and Urethrography

In 1933, Denny-Brown and Robertson²⁸ studied three cases of complete transection of the cauda equina by cystometry, with the proximal tip of the catheter in the bladder, in the prostatic urethra, and in the bulbous urethra. In the absence of roentgenologic aid, however, it is difficult to see how these observers could have been absolutely certain about the position of the proximal end of the catheter in the prostatic urethra, especially if the prostatic urethra were dilated, as it should be in this type of lesion. They found the degree of laxity of the internal sphincter directly proportional to the degree of vesical contraction both during actual discharge and during vesical contraction without discharge. They were unable to find any evidence of a functioning external sphincter, though the pressure at which the discharge

²⁸Denny-Brown, D., and Robertson, E. G.: The State of the Bladder and Its Sphincters in Complete Transverse Lesions of the Spinal Cord and Cauda Equina. *Brain* 56: 397-463, December 1933.

of urine began and terminated was much higher for the external than for the internal sphincter.

Watkins,²⁹ in 1936, found by cystography wide relaxation of the vesical neck in 7 of 8 cases of partial transection of the cauda equina. He also noted variations in the bladder neck at intervals of only a few minutes. Even when the internal sphincter was widely dilated, there was no escape of fluid. Watkins disagreed with the interpretation of Denny-Brown and Robertson, according to which the internal sphincter should have been closed in the interval between vesical contractions.



FIGURE 29.—Cystogram in patient with severe lesion of cauda equina. The bladder is atonic, and the bladder neck is relaxed.

Denny-Brown³⁰ reported additional cystographic observations on the bladder neck. He noted that in patients with automatic reflex urination, with only 25 cc. of opaque solution in the bladder, the region of the internal meatus had the shape of a small dimple. If distention was continued, the dimple widened to a small funnel, and the urethra was dilated down to the verumontanum. It was Denny-Brown's opinion that a funnel type of

²⁹ Watkins, K. H.: The Bladder Function in Spinal Injury. *Brit. J. Surg.* 23: 734-759, April 1936.

³⁰ See footnote 11, p. 71.

bladder neck is commonly found in lesions of the cauda equina, because the procedure used to demonstrate it excites contraction of the bladder.

Urethrography by the injection of a small amount of opaque material through the urethra from the external meatus should not produce sufficient intravesical pressure to cause reflex detrusor activity and should disclose the condition of the bladder neck in a resting state (figs. 30, 31, 32, 33, and 34).

Studies of changes in the bladder neck were made by Prather and Petroff³¹ in 129 cases of spinal cord injury at an Army paraplegic center.



FIGURE 30.—Urethrogram showing dilated bladder neck in patient in first stage of recovery. The dye in the bladder surrounds a stone.

The bladder neck showed some degree of dilatation in 30 of 36 cases of complete transection of the cord or cauda equina, a ratio of 5 dilated cases to 1 normal case. In 93 cases of partial transection of the cord or cauda equina, the ratio was 2.2 dilated cases to 1 normal case. In 29 cases of complete transection of the thoracic portion of the cord, the ratio of dilated to normal cases was almost 4 to 1, while all patients with complete transection of the cauda equina had some degree of dilatation at the internal

³¹ Prather, G. C., and Petroff, B.: Spinal Cord Injuries: Urethrographic Study of the Bladder Neck. *J. Urol.* 57: 274-284, February 1947.

urethral orifice. Dilatation of the neck was common in patients with partial transection at various levels. It occurred with increasing frequency from the level of the cervical region to the cauda equina.

In an effort to determine the significance of bladder tone or bladder capacity in urethrographic changes at the bladder neck, Prather and Petroff compared 10 patients with automatic bladders (the hypertonic type), with a capacity of about 150 cc., with 12 patients with other types of bladders, with a capacity of over 400 cc. Some degree of dilatation was common in both groups.



FIGURE 31.—Urethrogram in patient with complete transection in lower dorsal region. Filling defect caused by tip of suprapubic tube can be seen. Bladder neck is dilated.

A selected group of patients who had had urethrographic studies during a period of bladder drainage were reexamined 5 to 9 months later, when they were voiding and not on drainage. Patients with both partial and complete transection of the cord were included. While there might have been some changes in the shape of the prostatic urethra and bladder neck, little or no change in the degree of dilatation had occurred with the lapse of time or with changes in the status of the bladder.

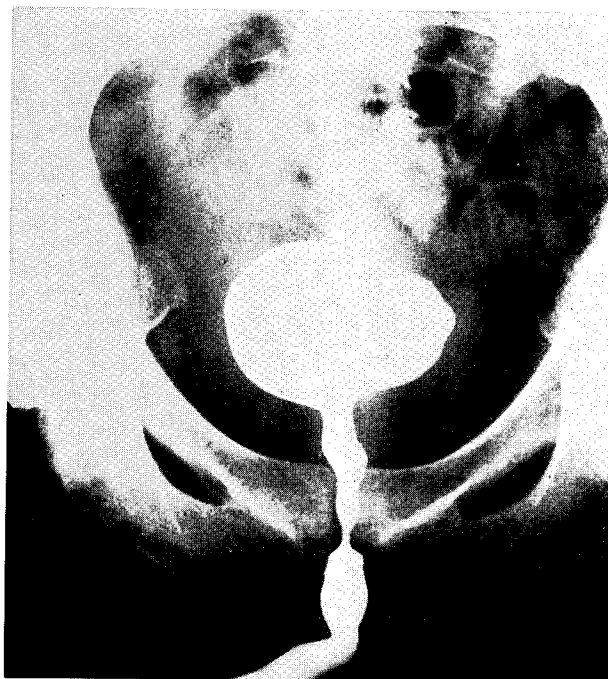

FIGURE 32.—Urethrogram in patient with complete transection in lower dorsal region of the spinal cord. He has good automatic reflex bladder with satisfactory capacity. The bladder neck is dilated.

Studies by various observers indicate that dilatation of the bladder neck is a common finding in patients with spinal cord injury, but the correlation of the observation with detrusor action is difficult at this time for three reasons:

1. The dilated bladder neck is common with both hypertonic and atonic types of bladder.
2. There is no marked change in dilatation over a period of months during which changes in bladder activity occur.
3. The groups studied are not absolutely parallel.

CARE OF THE BLADDER

The objectives of care of the bladder in Army paraplegic centers can be simply stated, as follows:

1. All patients should become ambulatory and free of urinary infection.
2. Patients who had sustained partial transection of the spinal cord should attain voluntary control of urination and be capable of emptying the bladder.

3. Patients who had sustained complete transections should attain involuntary, periodic reflex voiding at satisfactory intervals and should be capable of emptying the bladder.

These objectives were considerably easier to express than to achieve. Urinary drainage was provided during the first and second stages of recovery, or some arrangement was made to prevent overflow incontinence from contributing to the development of, or aggravation of, pressure sores over the sacral and trochanteric regions. That type of drainage was selected

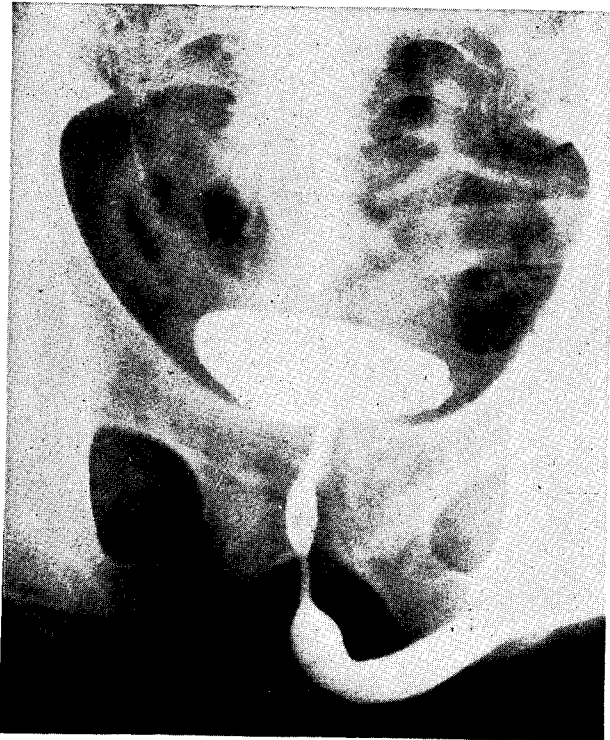

FIGURE 33.—Urethrogram in patient with partial transection of cauda equina. It shows no change from the normal. The patient was voiding voluntarily with good control.

which would keep bladder infection at a minimum, would not contribute to infection of the upper urinary tract, would avoid genital sepsis, would not interfere with ambulation, and would permit ultimate rehabilitation of the bladder to a voiding state.

Nondrainage Methods

By the nondrainage program in paraplegia, the bladder is permitted to distend and overflow, or manual expression of urine is accomplished by

abdominal massage of the organ every 4 to 6 hours. A catheter is not used in the hope that urinary infection may be avoided. Temporary distention of the bladder for a matter of hours is not harmful and does not interfere with the recovery process, but long-continued distention is harmful and interferes with resumption of function.

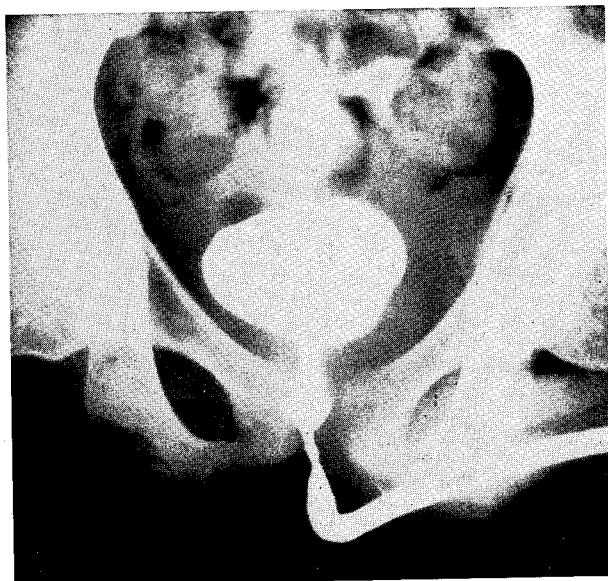

FIGURE 34.—Urethrocytogram in patient with partial transection of cauda equina. The bladder recovered sufficiently to permit voluntary voiding supplemented by straining with abdominal muscles. The bladder neck is dilated.

Over a period of years, various opinions have been expressed concerning this method of treatment. Besley,³² in 1917, stated that infection seldom occurred in the absence of catheterization and that distention of the bladder was not harmful either to the bladder or the kidneys. In World War I, Vellacott and Webb-Johnson³³ reported on 66 patients kept under observation in a forward area for an average of 3 weeks each. Most of these patients had been injured between 1 and 7 days earlier. Fifty had retention of urine. Only 1 of 10 in this group who had not been catheterized was infected, while 31 of 40 who had been catheterized had become infected. The preference of these observers was for a noncatheter program. Kidd, in 1919, wrote that the Credé method of emptying the bladder had been used in

³² Besley, F. A.: A Plea for Noncatheterization of the Urinary Bladder in Cases of Gunshot Wounds of the Spinal Column. *J.A.M.A.* 69: 638-639, 25 Aug. 1917.

³³ Vellacott, P. N., and Webb-Johnson, A. E.: Spinal Injury With Retention of Urine; the Avoidance of Catheterization. *Lancet* 1: 733-737, 3 May 1919.

France by British surgeons in 1917 but that many patients had become infected; he did not favor a nondrainage program.

David, in 1921, recommended that the catheter should not be used in patients seen early and without infection; if infection was present, this advice would not hold. Cahill,³⁴ in 1928, stated that, since World War I, he had preferred to use the Credé method or permit overflow. He observed a temporary rise in the nonprotein nitrogen of the blood but found that the level improved after reflex bladder action returned. Connors and Nash,³⁵ in 1934, reported on 54 patients (only 21 of whom had urinary retention) treated without catheterization; they maintained that urinary infection had not occurred in any. They used the Credé method every 4 to 6 hours and began treatment before maximum distention had been reached. Rupture of the bladder was not encountered, and only one patient developed decubiti, though an occasional patient required cystostomy. There is no mention in the paper of the ultimate state of the bladder.

Wesson,³⁶ in 1934, favored a noncatheter program and stated that overflow will occur in all cases and that conversion to an automatic bladder will take place within 96 hours; no statistics are given. Munger,³⁷ in 1937, advocated the noncatheter program if catheterization had not previously been employed and recommended suprapubic drainage in all infected cases.

Hinman³⁸ recommended a trial of manual expression of urine as the best method, if it is effective, for the early development of an automatic bladder, as well as the best method of avoiding urinary infection. Manual massage of the bladder from above downward toward the symphysis pubis by the palm of the hand must be performed every 4 hours by the clock. This method, Hinman granted, is time consuming, is predicated on the availability of conscientious personnel, and is applicable only when there is no urinary infection and no mechanical obstruction.

Brock,³⁹ in 1940, stated that the tendency to infection of the chronically overdistended bladder when this method is used is nearly as great as when catheterization and bladder irrigations are used, and Riches, in 1943, after only partial success with manual expression of urine, concluded that the method was neither safe nor certain for routine use.

³⁴ Cahill, G. F.: The Treatment of Bladder Paralysis Due to Non-Tabetic Spinal Cord Lesions. *Am. J. Surg.* 5: 442-444, November 1928.

³⁵ Connors, J. F., and Nash, I. E.: The Management of Urologic Complications in Injuries to the Spine; Report of 54 Cases Without a Single Infection in the Urinary Tract. *Am. J. Surg.* 26: 159-167, October 1934.

³⁶ Wesson, M. B.: Is the Use of a Catheter Ever Justified in Fractures of the Spine? *Urol. & Cutan. Rev.* 38: 572-579, August 1934.

³⁷ Munger, A. D.: The Urologic-Orthopedic Viewpoint on the Cord Bladder. *J. Urol.* 37: 54-59, January 1937.

³⁸ (1) Hinman, F.: The Treatment of Paralytic Bladder in Cases of Spinal Cord Injury. *Surgery* 4: 649-662, November 1938. (2) Hinman, F.: The Care of the Bladder at the Front When Paralyzed by Injuries to the Spinal Cord. *J. Urol.* 46: 499-504, September 1941. (3) Hinman, F.: Care of the Neurogenic Bladder; Abnormal and Genito-Urinary Injuries. Philadelphia: W. B. Saunders Co., 1942.

³⁹ Brock, Samuel (ed.): Injuries of the Skull, Brain and Spinal Cord: Neuro-Psychiatric, Surgical, and Medico-Legal Aspects. Baltimore: Williams & Wilkins Co., 1940.

A number of the earlier proponents of this form of treatment apparently advocated it because of their poor results with a program of intermittent catheterization. Unfortunately, there is no sizable series of cases on record describing the ultimate bladder function and the extent of rehabilitation achieved by the nondrainage technique. It is clearly not a method which can be employed when large numbers of patients must be treated at the same time or when transportation is involved in their management. Under those circumstances, it is doubtful that the program could be safe for the patient, from the standpoint of avoiding bedsores, or that it is best for the bladder should urinary infection develop. Even before World War II, there was a trend away from the method, and results obtained by other methods during the war supply no cause for regret that it was not used, nor have they led since to renewed interest in the noncatheter program.

Intermittent Catheter Drainage

It is generally agreed that in the management of spinal cord injuries, intermittent catheter drainage is the worst form of treatment which can be used. Thomson-Walker's report of the tragic English experience with it in World War I, in which it was used routinely in certain installations, should forever prohibit its further use. The estimated total death rate due to urinary sepsis in his series was 80 percent. Of 339 patients whom he personally observed 2 to 3 weeks after injury, 47 percent were dead within 8 weeks, and another 17 percent of those who survived to be transferred to another hospital later died of urinary infection. It was a well-established urologic principle before World War II that this type of drainage should not be used for more than a few days.

Constant Drainage

Kidd, in 1919, in an effort to avoid overdilatation of the bladder and the severe infection which results from intermittent catheterization, recommended drainage with a "tied in" catheter. This form of therapy has now been used in urologic cases for many years, and it was widely used in World War II. Its chief advantage is that it obviates the necessity for surgery (cystostomy or urethrostomy) and the time occupied by healing of a surgical wound.

The chief objection to drainage of the bladder by a urethral catheter is the possible occurrence of urethral or scrotal sepsis. Scrotal sepsis, although it may result in loss of part of the scrotal contents, is not dangerous to life or likely to delay recovery materially if it is treated properly. Peri-urethral abscess, however, with fistula formation at the penoscrotal junction, is a serious complication in the paraplegic patient. The opening heals only slowly, and plastic surgery may be necessary. When voiding is reestablished, it is often difficult, when the ordinary glass or metal urinal is used, to pre-

vent leakage of urine from the fistula onto the bed or the clothing. When leakage occurs, complete rehabilitation of the bladder may be delayed for weeks.

A practical consideration, which was particularly important in the large numbers of paraplegics handled in oversea theaters, is the daily attention required by the catheter and the rest of the drainage system used. Bladder irrigations are necessary to keep down infection, and, even if there is no evidence of incrustation, the catheter must be changed, with a sterile technique, at least every 7 to 10 days. The tactical situation often prevented the use of constant drainage by this method, desirable as it was, in oversea theaters in World War II.

Whenever catheter drainage was employed, certain precautions, in addition to the use of a nontraumatic, sterile technique, were essential. The catheter itself was always a No. 18 F. or a smaller size, since the urethra of the paralyzed patient has no more tolerance to pressure than the sacral and trochanteric regions. Either the two-holed (Robinson) soft rubber catheter or the balloon (Foley) catheter was used.

It was possible to use the Robinson catheter effectively if penile adhesive strapping could be properly maintained. The balloon catheter, however, with a 5-cc. bag, required less daily adjustment and was desirable because it avoided the possible penile constrictions and abrasions caused by adhesive tape. Repeated cystoscopic observations failed to reveal edema or necrosis of the bladder neck caused by the distended bag of this type of catheter. The balloon type of catheter is the only type which can be kept properly adjusted in the presence of priapism. Since intravesical prostatic enlargement is seldom present in men of the age group which made up the bulk of casualties in World War II, there was seldom difficulty in keeping the catheter in a satisfactory position for drainage within the bladder.

Methods of Irrigation

Syringe irrigation.—Facilities for syringe irrigation were always kept available, since this is an effective method and is occasionally necessary when the catheter becomes blocked by debris or clot. Its routine use, however, was impossible under military circumstances. It requires time and effort on the part of nursing personnel, and it requires a fresh set of sterile utensils for each irrigation on each patient. Moreover, since the catheter must be disconnected and reconnected at each treatment, the chances of cross infection are obvious.

Closed system with manual control.—This type of irrigation, which has been commonly used in urologic practice for many years, was widely employed during World War II, by means of an apparatus (fig. 35) similar to that used by Nesbit and Gordon.

This apparatus proved very satisfactory under military circumstances. The unit, which was kept ready in sterile packs for immediate use, could be

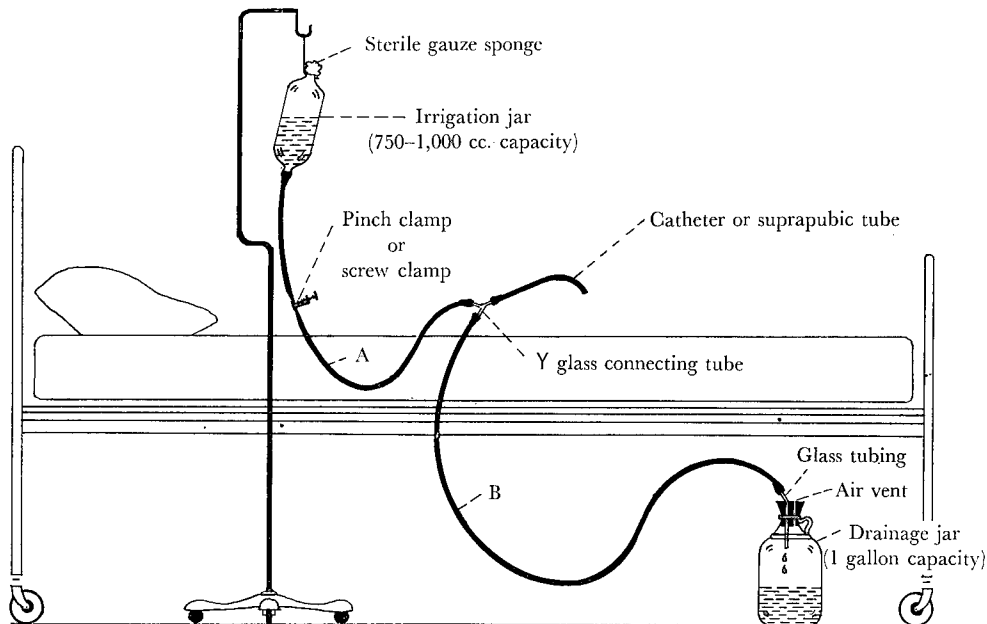

FIGURE 35.—Diagram for closed system of drainage and irrigation of bladder, with manual control. To irrigate bladder, clamp on A is opened while B is pinched off. After the desired volume of fluid has entered the bladder, A is pinched off and B is released. After this maneuver has been repeated several times, the clamp on A is reapplied.

easily sterilized in the autoclave. It was simple to set up and was quickly disassembled for resterilization. Setting it up took no longer than connecting the ordinary drainage tube, and, over a long period of time, the saving in time and effort was considerable. The bladder was thoroughly cleansed at each treatment because the irrigating fluid entered by force of gravity. As long as the irrigating fluid was kept sterile, attendants could irrigate the bladder easily, quickly, and without chance of contamination. The amount to be run in at each bladder fill was readily seen on the calibrated irrigating jar, and errors were practically impossible. The patient who had the use of his arms could be taught to irrigate himself a certain number of times a day and could do it quite as well as an attendant. With this system, there was no difficulty with failure of drainage because of air in the tubing. There was also no difficulty if drainage had to be reinstated after a period of ambulation. For these various reasons, it was the general opinion among Army urologic surgeons that this system was simple, effective, compatible with optimum functional activity of the bladder, and, in general, well adapted to military use.

Closed system with automatic control (tidal drainage).—Tidal drainage (the nomenclature employed by Munro and Hahn⁴⁰) provides a closed

⁴⁰ Munro, D., and Hahn, J.: Tidal Drainage of the Urinary Bladder; Preliminary Report of This Method of Treatment as Applied to "Cord Bladders" With Description of Apparatus. *New England J. Med.* 212: 229-239, 7 Feb. 1935.

system of drainage and bladder irrigation in which periodic irrigation and emptying occur automatically. Laver,⁴¹ in 1917, described an automatic irrigator based on the principle of siphonage and on the observation that water finds its own level. Munro and Hahn, in 1935, described a more complicated apparatus for the same purpose, and Munro championed tidal drainage after that time. Lawrie and Nathan,⁴² Bellis,⁴³ Stewart,⁴⁴ and Cone and Bridgers⁴⁵ all described simplified devices for tidal drainage which are effective and which permit cystometric studies without additional equipment. All models have the same objective, to provide automatic filling and emptying of the bladder at a predetermined level of intravesical pressure. To use any of them intelligently, previous cystometric studies are necessary, so that the level of the siphon loop may be properly adjusted. The system will not function properly if there is air in the rubber tubing leading to the bladder, nor will the emptying of the bladder be effective if the opening of the air vent is larger than a 22-gage needle.

Munro⁴⁶ is of the opinion that the early use of tidal drainage will avoid urinary infection and has published statistics to prove the point.⁴⁷ Hinman, whose experience, like Munro's, was civilian, advocated this method in cases in which manual expression is contraindicated or impossible; he believed that it hastens the development of an automatic bladder provided that detailed attention is given to the care of the catheter and apparatus. Military urologic surgeons were generally in favor of it. Stewart and other English neurosurgeons⁴⁸ preferred tidal drainage to other methods when facilities and trained personnel were available, and Riches was of the opinion that the time requirement for the development of a reflex bladder was slightly less when this form of treatment was used. American neurosurgeons thought it an excellent method of treatment, but most of them did not consider it essential for optimum recovery or rehabilitation of the paralyzed bladder.

The disadvantages of tidal drainage in both military and civilian practice are those common to all methods which require the use of urethral catheters over long periods of time; that is, possible urethral or scrotal sepsis. Munro, in his article on rehabilitation, found the incidence of complications less with tidal drainage than with other forms of treatment.

⁴¹ Laver, C. H.: An Automatic Bladder Irrigator. *Guy's Hosp. Gaz.* 21: 71-74, 1917.

⁴² Lawrie, R. S., and Nathan, P. W.: Automatic Tidal Drainage of the Bladder. *Lancet* 2: 1072, 18 Nov. 1939.

⁴³ Bellis, C. J.: An Improved Apparatus for Tidal Drainage of the Urinary Bladder and Empty Cavitities. *Surgery* 8: 791-797, November 1940.

⁴⁴ Stewart, O. W.: The Neurogenic Bladder; Combined Tidal Irrigator and Cystometer. *Lancet* 1: 287-289, 7 Mar. 1942.

⁴⁵ Cone, W. V., and Bridgers, W. H.: A Combined Tidal Irrigator and Cystometer for Management of the Paralyzed Bladder. *Surg. Gynec. & Obst.* 75: 61-66, July 1942.

⁴⁶ (1) See footnote 9(2), p. 69. (2) Munro, D.: Rehabilitation of Patients Totally Paralyzed Below the Waist, With Special Reference to Making Them Ambulatory and Capable of Earning Their Own Living; Control of Urination. *New England J. Med.* 234: 207-216, 14 Feb. 1946.

⁴⁷ See footnote 9(2), p. 69.

⁴⁸ Discussion on the Treatment of the Paralyzed Bladder. *Proc. Royal Soc. Med.* 36: 197-202, 26 Nov. 1942.

Certain objections have been raised to the apparatus itself. Lewis found that the bladder was not always emptied, either because of a change in the patient's position or because of air trapping; he and Thomas⁴⁹ both thought that thorough bladder irrigation was necessary daily. Bumpus, Nourse, and Thompson, who used tidal drainage at some stage of convalescence in most of the naval casualties under their care, found supplemental irrigations necessary to prevent puddling of infected urine and accumulation of calcium debris in the bladder, in spite of their best efforts to maintain efficient automatic drainage.

Irrigating solutions.—The solution used as an irrigating medium, regardless of the system of drainage used, was always sterile, antiseptic, non-irritating, and preferably of such quality as to delay or prevent phosphatic deposits on glass and rubber tubing. Sterile water, saline solution, boric acid, potassium permanganate, sulfanilamide, and solutions G and M proposed by Suby and Albright⁵⁰ were all tried with varying degrees of success.

Solution G was found too irritating for long-continued use in the bladder, as shown by bloody mucus in the return fluid. Solution M,⁵¹ which did not have this undesirable feature, was readily autoclaved and proved more effective than boric acid solution in delaying incrustations on tubing, though the ingredients of the formula were not always immediately available in the large quantities needed. Boric acid solution was a satisfactory substitute. Whatever solution was used, it was thought important to give it a distinctive coloring (by the use of a small quantity of methylene blue) to prevent errors and substitutions.

Drugs

The effect of drugs on reflex activity of the bladder after spinal cord injury has perhaps not been fully exploited. Nesbit and Gordon found that efforts to influence either sympathetic or parasympathetic activity by drugs were without clinical benefit. Riches found that drugs of the acetylcholine type had no favorable influence on the bladder during spinal shock but appeared to enhance reflex contractions once recovery had set in. The use of atropine in an effort to lengthen the intervals between voidings in patients with the reflex automatic type of bladder after complete transection was of benefit in some ambulatory cases, but actual data are not available.

⁴⁹ Thomas, W. H.: Tidal Drainage and Tidal Irrigation. *Urol. & Cutan. Rev.* 45: 147-149, March 1941.

⁵⁰ Suby, H. I., and Albright, F.: Dissolution of Phosphatic Urinary Calculi by Retrograde Introduction of Citrate Solution Containing Magnesium. *New England J. Med.* 228: 81-91, 21 Jan. 1943.

⁵¹ Citric acid (monohydrous)	32.35
Magnesium oxide (anhydrous)	3.84
Sodium carbonate (anhydrous)	8.34
Distilled water q.s.ad.	1,000.00

SURGICAL MEASURES

Suprapubic Cystostomy

Suprapubic drainage of urine has been advocated for many years as a method of avoiding urethral sepsis during paralysis of the bladder and of protecting the upper urinary tract against infection. Thomson-Walker⁵² advocated this method during World War I, and 20 years later he was still in favor of it if Credé methods failed. Boyd and Bailey⁵³ recommended it as the logical method of primary treatment, and Munger favored it when urinary infection was present. Hinman stated that it should be used in civilian practice when other methods of treatment have failed and should be used at once in battle-incurred spinal cord injuries of considerable degree. Riches⁵⁴ advocated it at an early stage in the hope of preventing renal infection, though it has, of course, no influence on already established upper urinary tract infection. The comprehensive reports of Thomson-Walker and Riches and the large experience in the U.S. Army in World War II all indicate that cystostomy does not adversely influence the rehabilitation of the bladder to a voiding state or reduce bladder capacity even after months of drainage if bladder infection is kept minimal. During World War II, secondary closure of the suprapubic sinus was only occasionally necessary.

Suprapubic drainage did not interfere with ambulation in paraplegics or with frequent changes of position in bed, although it proved troublesome if a Stryker frame had to be used over a long period. The tube could be connected to a closed system of drainage, and irrigation could be manually controlled to avoid possible cross-contamination by personnel using syringe irrigations. Patients could be taught to irrigate themselves as required, and, if the cystostomy had been performed properly, cystometric determinations could be carried out via the suprapubic tube.

The chief disadvantage of the method is that it is a surgical procedure and that it takes 3 to 4 weeks for the sinus to heal during a period of urethral catheter drainage, when rehabilitation of the bladder is at hand. Like a urethral catheter, the bladder catheter requires periodic changing, but the experience in World War II definitely refuted the assertion that this type of drainage leads to shrinkage of the bladder capacity. The U.S. experience also did not support either the contention that the tube is prone to rot and break, that it fails to prevent puddling, and that it promotes shrinkage and fibrosis of the bladder wall,⁵⁵ or the complaint of leakage about the catheter. The latter difficulty was not encountered in any properly performed and properly maintained suprapubic cystostomy.

⁵² Thomson-Walker, J.: The Bladder in Gunshot and Other Injuries of the Spinal Cord. *Lancet* 1: 173-179, 3 Feb. 1917.

⁵³ Boyd, M. L., and Bailey, M. K.: Suprapubic Cystostomy in Bladder Paralysis. *Tr. Am. A. Genito-Urin. Surgeons* 21: 305-315, 1928.

⁵⁴ See footnotes 10, p. 71, and 48, p. 93.

⁵⁵ See footnote 9(1), p. 69.

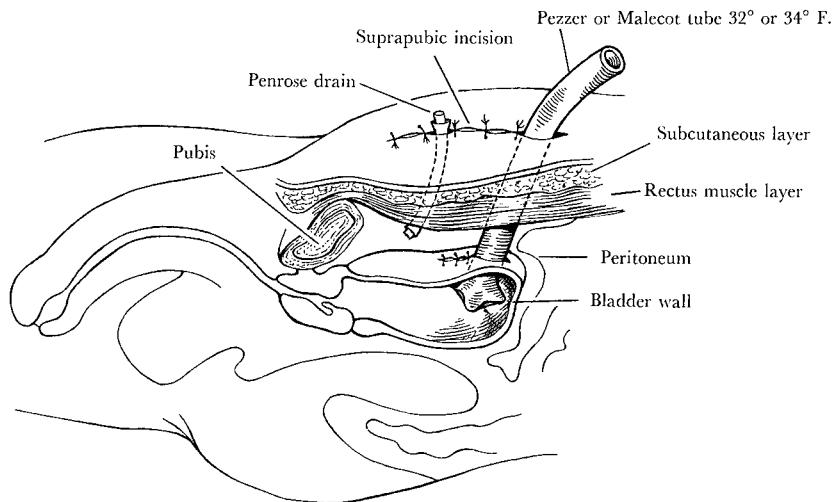

FIGURE 36.—Correct placement of suprapubic tube high in vertex of bladder. This position avoids pressure on the trigone, permits easy surgical reentry into the bladder, and leaves an oblique sinus when the tube is removed.

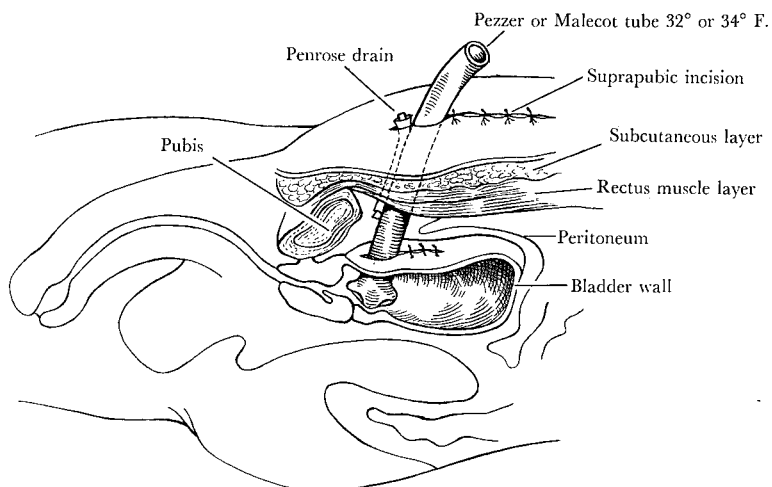

FIGURE 37.—Wrong placement of suprapubic tube, causing pressure on trigone with possible edema around ureteral orifices. With the tube in this position, it is difficult to obtain further surgical exposure of the bladder without opening the peritoneum. After removal of the suprapubic tube, the residual sinus is short and may require a longer period to heal than an oblique sinus.

The placing of the tube was extremely important.⁵⁶ It was introduced high in the dome of the bladder (fig. 36) and was brought out through the upper end of the skin incision. These precautions, which prevented riding of the proximal end of the tube on the trigone and ureteral orifice, resulted in an oblique sinus, which facilitated later closure. This technique also avoided the possibility of infection of the pubic bone which might occur if the tube were placed at the lower end of the incision adjacent to the pubic bone (fig. 37).

Perineal Urethrostomy

Lewis'⁵⁷ suggestion that unurethrostomy in the bulbous urethra, with insertion of a Malecot tube to the bladder, was seldom used in U.S. paraplegic casualties. The method seems to have numerous objections. It avoids peri-urethral abscess and fistula at the penoscrotal angle, it is true, but it does not diminish the possibility of prostatic and scrotal sepsis. The necessary proximity of the incision and the channel for the tube to an incontinent anus invite urinary infection. The possible bad effect of pressure by the tube on perineal structures when the patient is in the sitting position may delay wheelchair activities. When there is delay in healing of the urethrostomy opening, prolonged urethral catheter drainage is required, because the buttocks are wet each time the patient voids. Clearly, this is not a satisfactory method for routine use.

Cystoscopic Procedures

Cystoscopic removal of bladder calculi, whenever they were present, was necessary before satisfactory rehabilitation could be accomplished. Many small stones could be removed through the sheath of the cystoscope or resectoscope with the aid of the Ellik evacuator. Larger calculi could be crushed and removed by irrigation. These maneuvers were carried out through the cystostomy wound or, if the bladder was intact, through the urethra. The bladder was always inspected for possible calculi before the patient was changed from a suprapubic to a urethral catheter program.

Resection of the bladder neck, if used selectively, proved a useful adjunct method in a small proportion of cases after it was believed that maximum neurogenic activity had been attained. For an eventual satisfactory functional result in paraplegic subjects, reflex activity of bladder musculature must be present, and sufficient sphincteric or urethral resistance must remain to avoid continuous incontinence. Although, in many instances,

⁵⁶ (1) See footnote 48, p. 93. (2) Hamm, F. C.; Suprapubic Cystostomy. *Mil. Surgeon* 96: 241-244, March 1945. (3) Prather, G. C.; Suprapubic Cystostomy. *Bull. U.S. Army M. Dept.*, No. 81, pp. 96-98, October 1944.

⁵⁷ Lewis, L. G.; Perineal Urethrostomy for Drainage of Neurological Bladders. *Bull. U.S. Army M. Dept.*, No. 69, pp. 46-48, October 1943.

a well-defined widening or relaxation of the bladder neck was revealed by urethrographic and cystoscopic examination in paraplegic casualties, in the great majority, the desired end result of functional control and efficient emptying could be obtained without revision of the bladder neck. In instances of inefficient emptying of the bladder with demonstrable adequate reflex activity on cystometry, resection of the bladder neck was sometimes vital in the restoration of satisfactory bladder activity.

Bumpus, Nourse, and Thompson, as the result of experience in the Navy in World War II, stated that dysfunction following low spinal (cauda equina) lesions was most responsive to transurethral resection. Results were less spectacular but still worthwhile in patients with automatic reflex voiding who had an appreciable bladder residue. Their practice was to resect small amounts of tissue from the entire circumference of the bladder neck, the total volume of the excised portions not exceeding 10 gm.

Experiences with resection of the bladder neck were not universally successful in Army paraplegic centers, though some excellent results were obtained. The method was probably most useful in patients whose natural progress was not complete. To achieve the best results, as well as to avoid doing harm, bladder neck resection was used selectively and only after it was thought that maximum neurogenic activity had been attained.

BLADDER TRAINING

Bladder training for paraplegic patients with complete transection after reflex bladder action had become reestablished was frequently very effective when the plan devised by Munro⁵⁸ was employed. The urethral catheter was clamped off at intervals of 1½ to 3 hours, in the expectation that the bladder would accommodate itself to this time schedule, so that the patient could void at regular intervals. When this had been accomplished, the patient was given a trial on a similar schedule without the catheter.

COMPARISON OF METHODS OF BLADDER MANAGEMENT

It is difficult to compare the effects of some of the methods described above, for the caliber of the attending personnel appeared to be as important as the method, if not more important. Any method in the hands of unskilled individuals could end in disaster. Several of the methods in expert hands could produce gratifying results.

In the description of a method of treatment, perfect technique in skilled hands, experience with the method, availability of equipment, and knowledge of potential complications are all assumed. In time of war, when treatment often had to be started before a hospital for definitive care was reached, and when problems of transportation were encountered, these ideal conditions were unattainable. Furthermore, it was often difficult to compare effective-

⁵⁸ See footnote 46(2), p. 93.

ness of methods except on a mass basis, and even then several methods might have been employed in an individual patient.

Except in time of war, few individuals have a large experience with paraplegic patients. Those who do usually have one method of treatment which they believe the best. They therefore report the results of one method instead of a comparative study of results of different methods with the same skilled personnel. Neurosurgeons not trained in urologic surgery prefer methods not involving detailed urologic procedures if they do not appear necessary. Although neurosurgeons, principally Munro, have contributed more to the rehabilitation of the bladder in civilian life than urologists, it remains for the urologist with his various diagnostic and therapeutic procedures to make valid and conclusive comparisons of methods of treatment.⁵⁹ The opportunity, however, is open only to the urologist who is interested, ingenious, and skilled, and who has access to an appreciable number of paraplegic patients.

The review of a number of reports on the treatment of the bladder after spinal cord injury, as well as observations of patients treated by various methods during World War II, permit the following statements:

1. A program of intermittent catheterization is certain to lead to disaster.

2. A nondrainage program, with overflow voiding or Credé emptying of the bladder, may be used in the individual case unless there is evidence of urinary infection, though it is difficult to maintain a dry bed and avoid decubitus ulcers. Nondrainage is not a feasible technique when large numbers of patients are to be cared for or when attendant personnel is limited. Eventual rehabilitation of the bladder is possible.

3. Drainage by urethral catheter, while it is an accepted method, must be supplemented by bladder irrigations, under sterile precautions, with a closed system that is either automatically or manually controlled. Careful hygienic attention to the catheter and urethra is required, and a properly working irrigating system is essential. Urethral sepsis and scrotal sepsis are potential complications. The choice between manually controlled irrigation and tidal irrigation is open and depends upon the availability of equipment and training of the personnel. Rehabilitation of the bladder to a voiding state is probable.

Suprapubic drainage with a properly placed tube is an accepted method, perhaps the preferable method, if a long period of bladder drainage appears necessary or if transportation problems make the urethral catheter program difficult. A closed system of irrigation is advisable. Periodic change of the tube is mandatory. This method, while it avoids a certain number of genital complications, eventually requires a period of urethral drainage during closure of the suprapubic sinus. Rehabilitation of the bladder to a voiding

⁵⁹ Important studies have been made in Veterans' Administration hospitals since the end of World War II.

state is probable but requires a slightly longer time than the urethral catheter method.

Removal of bladder calculi is necessary for proper bladder function, regardless of the type of drainage employed, and resection of the bladder neck may be required in some cases to facilitate efficient emptying of the bladder.

STATUS OF THE UPPER URINARY TRACT AFTER INJURY OF THE SPINAL CORD

Numerous observations⁶⁰ indicate that the totally denervated kidney can carry on all the renal function essential to life. There also appears to be no anatomic physiologic change in the ureters directly attributable either to injured nerve tissue or to the immediate altered bladder physiology.⁶¹ Other observations indicate that ureteral reflux is not likely to occur⁶² and that there is no tendency toward hydronephrosis.⁶³ Intravenous urography and cystography in paraplegics studied in general hospitals confirmed these observations. In the absence of obstructive pathologic changes independent of bladder dysfunction, urograms were normal, and reflux was observed in only the occasional case, in which it could probably be explained by localized changes in the ureteral orifice as the result of inflammation, edema, and similar changes rather than by physiologic changes caused by the spinal injury.

Observations on patients with spinal cord injuries sustained in World War II confirm the observations made in World War I that, after such injuries, renal function is maintained satisfactorily in the absence of complicating renal infection or calculi formation.⁶⁴ These observations covered periods up to 2 years and included many patients whose bladders had been rehabilitated to a voiding state. A much longer period of time must elapse before the status of the upper urinary tract can be reported in a large series of paraplegic patients, but at the time of writing there are some indications of upper tract deterioration in patients with autonomous bladder function over a period of many months. Sporadic case reports⁶⁵ and individual observations suggest that a long-term study may reveal an increasing incidence of upper urinary tract dilatation, especially if bladder emptying is incomplete or if inflammatory processes have permanently altered the vesi-

⁶⁰ White, James C., and Smithwick, Reginald H.: *The Autonomic Nervous System*. New York: The Macmillan Co., 1941.

⁶¹ Gruber, C. M.: *The Autonomic Innervation of the Genito-Urinary System*. *Rev.* 13: 497-609, October 1933.

⁶² (1) See footnote 24, p. 80. (2) Fullerton, A.: *A Note on the State of the Ureters and Their Orifices in Cases of Gunshot Wounds of the Spine*. *Brit. M.J.* 1: 124-125, 1 Feb. 1919. (3) Plaggemeyer, H. W.: *Shell Fractures of the Spine*. *J.A.M.A.* 73: 1599-1604, 22 Nov. 1919.

⁶³ See footnote 25, p. 80.

⁶⁴ See footnote 23, p. 80.

⁶⁵ Hepler, A. B.: *Late Results of Paralysis of the Bladder Following Fracture of the Spine; Value of Excretory Urograms in Demonstrating These Changes*. *S. Clin. North America* 13: 1379-1382, December 1933.

coureteral junction. For a proper interpretation of upper urinary tract observations years after spinal cord injury, earlier studies on each patient must be available for comparison.⁶⁶

STATUS OF THE SEX ORGANS AFTER INJURY OF THE SPINAL CORD

After injury to the spinal cord and recovery from spinal shock, reflex erection of the penis and priapism are not uncommon. Ejaculation has also been described. Cobb and Coleman,⁶⁷ in a study of 20 cases, found that after injuries to the cervical portion of the cord, sexual function, as a rule, was affected relatively more severely than urinary or rectal function. In lower cord injuries, sex potency might return while there was still lack of control over urine and feces. The World War II experiences were not completely in accord with these findings. Some patients with partial transection of the cauda equina had satisfactory marital experiences, but others found themselves impotent for a period of at least a year after injury. Observations on this point are incomplete.⁶⁸

GENITOURINARY COMPLICATIONS OF INJURIES TO THE SPINAL CORD

Even before the age of Lister, thought had been given to changes in the urine of paraplegic patients. Curling,⁶⁹ in 1833 and in 1836, stated that the alkaline state of the urine was produced primarily by morbid secretions of the bladder and secondarily by the debilitated state of the kidneys. Burne,⁷⁰ in 1833, took the same point of view, on the basis of finding foul ammoniacal urine in the bladder and acid urine in the kidneys.

Renal Complications

Renal infection and calculus formation were the two serious urinary tract complications encountered most frequently in World War II. Very often they existed together, each condition enhancing the other at the expense of the host.

Infections.—There was no attempt in World War II to differentiate clearly between pyelonephritis and so-called cortical abscesses of the kidney. It is likely that a number of patients considered to have nephritis actually had microscopic abscesses in the renal parenchyma.

⁶⁶ Extensive studies along these various lines have been made in Veterans' Administration hospitals since the end of World War II.

⁶⁷ Cobb, S., and Coleman, C. C.: *The Course of Recovery Following Trauma of the Spinal Cord*. Arch. Surg. 3: 132-139, July 1921.

⁶⁸ Further studies have been made in Veterans' Administration hospitals.

⁶⁹ (1) Curling, T. B.: *Essay on Affections of the Bladder in Paraplegia*. London M. Gaz. 13: 76-83, 1833. (2) Curling, T. B.: *Further Observations on Affections of the Bladder in Paraplegia*. London M. Gaz. 18: 325-331, 1836.

⁷⁰ Burne, J.: *On the State of the Bladder in Paraplegia*. London M. Gaz. 13: 353-355, 1833.

The mortality rate from renal infection, both in World War I and afterward, was alarmingly high, chiefly because efficient urinary antiseptics were not then available. Thomson-Walker's⁷¹ report on a large series of patients could not fail to create concern, since 47 percent died within 8 weeks and still others at a later date. Vellacott and Webb-Johnson reported 10 percent of deaths from urologic causes during the first month after injury, and it may be assumed that other patients in their series later succumbed to the same causes.

During World War II, intravenous urography, more effective medicinal agents, and better handling of the paralyzed bladder helped to reduce the toll of renal sepsis. Although there are no data for the first few weeks after injury, those patients who were evacuated to the United States in general did well.⁷²

Raines, at the conference on spinal cord injuries, reported no deaths from urologic causes in a series of over 100 cases observed over a period of months. Petroff⁷³ had only 1 death among 70 patients over a period of a year or more, and Prather⁷⁴ reported only 1 death from urologic disease in a series of 61 cases observed over a period of 18 months.

In patients who appeared to have renal infection after spinal cord injury, the diagnosis was usually made on the basis of fever and, perhaps, pain, nausea, vomiting, and urinary findings, or on the exclusion of other causes. The condition might be acute, recurrent, or chronic. In only the acute and recurrent types did the temperature chart usually give a clue.

The mode of infection, just as in patients without spinal injuries, was by the hematogenous, lymphatic, or ascending routes. It is difficult to prove which route was most common. As pointed out previously, reflux could not be demonstrated in the majority of cases, and it should not be assumed that the ascending intraureteral path was the principal route. There were many other possibilities, including transmission to the kidney via periureteral lymphatics from an infected bladder; dissemination via the bloodstream from septic foci in other parts of the body, including areas injured by penetrating missiles and bedsores; and transmission from the intestinal tract. Petroff found positive blood cultures in three cases.

The types of organisms responsible for renal infection are multiple. Although the organisms found in urine from the bladder do not necessarily mean that the same bacteria are causing the renal infection, they probably offer the best general guide that is available without ureteral catheterization or surgery. Raines found *Proteus*, *Aerobacter aerogenes*, and *Esch. coli* the most common bacteria in cases in which pure cultures of urine were ob-

⁷¹ See footnote 52, p. 95.

⁷² Conference on Spinal Cord Injuries, Halloran General Hospital and Thomas M. England General Hospital, 19-20 Oct. 1945.

⁷³ Urological Conference and Symposium on the Paralyzed Patient, Newton D. Baker General Hospital, 11-12 May 1945.

⁷⁴ Prather, G. C.: Spinal Cord Injuries: Care of the Bladder. *J. Urol.* 57: 15-28, January 1947.

tained. In combination with these varieties, Raines frequently found non-hemolytic streptococci, *Alkaligenes fecalis*, and *Staphylococcus aureus*. Petroff found the bacilli just mentioned more difficult to eradicate than the coccic forms. Prather found that cultural studies of urine specimens from patients on drainage usually showed a mixed infection. The bacteria most frequently encountered were staphylococci, *Ps. aeruginosa*, *P. vulgaris*, *Esch. coli*, and *B. cloacae*.

The diagnosis of renal infection was usually made after an abrupt rise in temperature, sometimes preceded by a chill. Pain was not present unless the level of anesthesia was below the level of the upper abdomen. If the patient was on drainage and had had a mild urinary infection, the urine sometimes showed gross changes. This was not often a reliable sign. Patients who were voiding clear urine usually developed cloudy urine with the onset of an acute or recurrent infection.

The first important question raised by a temperature elevation caused by renal infection was whether or not there was obstruction at some point in the upper urinary tract. If there was no obstruction, medicinal measures were pushed to the limit. If there was obstruction, these measures were seldom sufficient. Since ureteral catheterization is not a satisfactory routine procedure in this type of case, intravenous urography was used as a good way of disclosing obstruction of the kidney. The value of periodic routine studies during the afebrile period or normal convalescence was enhanced by the ability to compare them with films taken later during febrile episodes. Only by periodic examinations of this type could the upper urinary tract be indirectly visualized and the correct interpretation given to an episode of renal infection. There was no hesitancy about using intravenous urography during the first days of a febrile reaction.

Treatment of renal infections was far more effective during World War II than it was some years ago, even though complete and permanent sterilization of the urine was not always attained. Because of the ever-present necessity of forcing fluids to combat calculus formation, together with the desirability of a high fluid output in renal infection, medicinal agents which required restricted urinary output for their best effect were not useful. Fortunately, the use of sulfonamides, penicillin, and streptomycin is not incompatible with a high urinary output. In addition to the use of these agents, a high liquid intake and output, attention to the general nutritional state, transfusions of whole blood, plasma, amino acids, and vitamins played an important part in the treatment.

For renal infections caused by gram-negative bacilli, the sulfonamides appeared to be the best agents for routine use except in patients who had developed sensitivity to them. Sulfadiazine or sulfathiazole in 1-gm. doses by mouth every 4 to 6 hours around the clock, with an equal quantity of soda bicarbonate, was the customary treatment for the ordinary renal infection. Larger doses were seldom more effective, and even smaller quantities

were sometimes just as useful. Once begun, medication was continued for a period of 5 to 7 days; dosages of 1 gm. 4 times a day over a period of several weeks could be given without untoward reaction. If these drugs could not be used by mouth, sulfadiazine was utilized intravenously. Although there is no apparent reason why a patient with spinal cord injury should be exempt from the renal complications of the sulfonamides, no instance of this type of anuria seems to have occurred.

Streptomycin proved a valuable agent in the treatment of gram-negative infections of the urinary tract, especially in relieving virulent febrile stages which had not been controlled by the sulfonamides. It could be used simultaneously with sulfonamides or with penicillin. Although the optimum dosage of streptomycin had not yet been agreed upon, it was evident that large doses at the beginning of treatment helped to prevent the development of resistance by the organism. With a standard of 1,000,000 units to the gram, 300,000 to 400,000 units intramuscularly every 3 hours appeared to be the average dose; 5 to 7 consecutive days of medication were necessary for a fair trial. Alyea⁷⁵ found the drug most effective in an alkaline urine.

Penicillin seemed to be the most effective agent against coccic infections in the kidney. The usual doses were 20,000 to 40,000 units intramuscularly every 3 hours. Penicillin could be used simultaneously with streptomycin or the sulfonamides. It was believed to be most effective in an acid urine.

Ureteral catheterization, drainage, and lavage were sometimes employed in the treatment of renal infection. These methods were always used cautiously, but, on occasion, their heroic employment served to relieve obstruction, facilitate diagnosis, and prepare patients for operation. Very thorough irrigation of the bladder was desirable before ureteral catheters were passed through it on their way to the kidney.

Calculi.—Data accumulated during World War II showed a disturbingly high incidence of renal calculi in paraplegics over a period of approximately 15 months after injury. Prather, by routine intravenous urography at intervals of 6 to 8 weeks, demonstrated calculi in 31.5 percent of patients with complete transection and in 20 percent of patients with partial transection. Other observers, who did not differentiate between complete and incomplete lesions, also reported a high incidence. Petroff reported 20 percent; Bowie, 18.6 percent; Riba, 13 percent; and Malcolm, 9 percent.⁷⁶

The frequent occurrence of renal calculi in the recumbent patient is a well-established phenomenon. The three known etiologic factors are infection, stasis, and hypercalciuria.⁷⁷ Patients with injury of the spinal cord were necessarily confined to bed for periods of weeks or longer until stability of bony structures permitted ambulation. It was not surprising, therefore, to find a high incidence of stone in this group.

⁷⁵ Personal communication, E. P. Alyea to G. C. Prather.

⁷⁶ Transverse Myelitis Conference, Hammond General Hospital, 24-25 June 1945.

⁷⁷ Flocks, R. H.: "Early" Calcium Urolithiasis. *J.A.M.A.* 130: 913-918, 6 Apr. 1946.

According to Prather, routine intravenous urograms in a series of 60 patients, many of whom had been bedfast and on bladder drainage for several months, showed no dilatation of kidney pelves or ureters. Similar studies, several months later, when voiding had been reestablished, likewise revealed no upper urinary tract dilatation. Calculus formation is probably not due to any gross anatomic change that can be demonstrated by pyelographic study.

Calculi can form rather quickly. Large stones were found to develop in a period of 5 months, and it was not unusual to see a definite increase in size over an interval of 2 months. Bilateral stone formation was common, but no more so than the unilateral distribution (figs. 38, 39, 40, 41, 42, and 43).

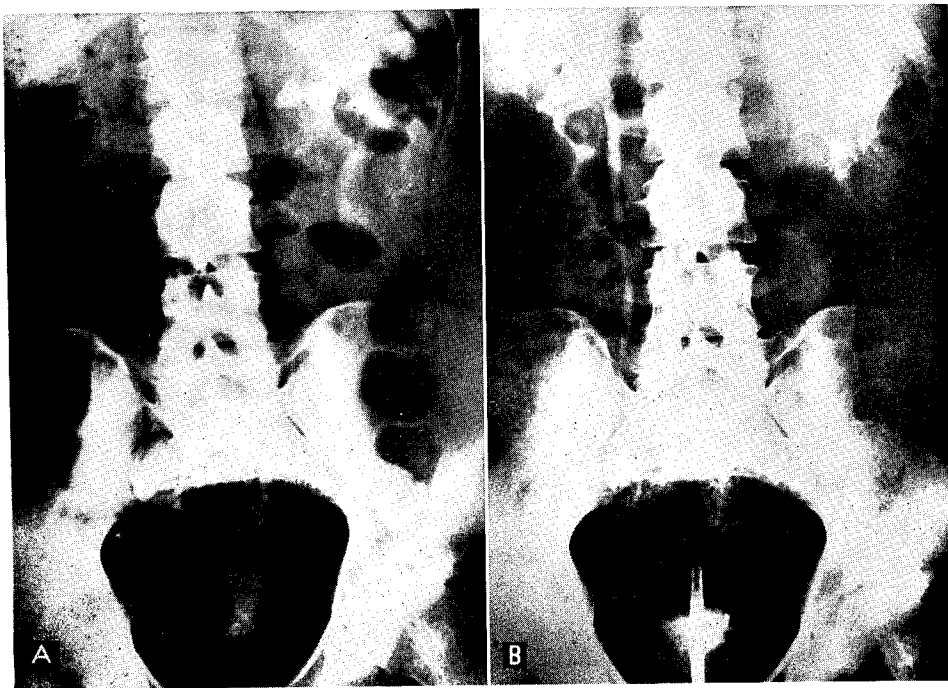

FIGURE 38.—Roentgenograms showing renal calculi. A. Two left renal calculi in paraplegic patient with high fever. At the time of operation, the left kidney contained multiple cortical abscesses. Left pyelolithotomy was done rather than nephrectomy because of a calculus in the upper pole of the opposite kidney. The patient made an excellent recovery from operation. B. Postoperative intravenous urogram following surgical removal of left renal calculi from severely septic kidney. The kidney had excellent function.

Symptoms were lacking in patients with transection in the upper part of the spinal cord. Even those with a level of anesthesia below the kidney area seemed to have less pain than the nonparalyzed patient. Gross hematuria occurred occasionally. It was seen more often in orthopedic patients

confined to bed than in paraplegic patients. Nausea and vomiting, which were common symptoms, were often thought to be due to a dietary upset until the correct diagnosis was established.

Accurate diagnosis could be established only by roentgenologic studies. Intravenous pyelography was preferred to the retrograde technique as a routine. If proper treatment was to be given, it was imperative to determine



FIGURE 39.—Intravenous urogram showing small calculus in upper right ureter completely obstructing right kidney. There is also a small stone in the right kidney. Both calculi were removed surgically at the same operation.

the degree of obstruction caused by the stone. At times, retrograde examination was necessary to make the diagnosis, but this was done only after painstaking irrigation of the bladder to prevent the introduction of organisms into a clean field or the introduction of new organisms into a locale already infected. Stereoscopic and oblique films often aided in the localization of opaque shadows and were sometimes necessary to avoid mistakes in interpretation.

Treatment was first directed against the known causative factors. The incidence of renal infection could be reduced by proper treatment of the bladder, by improvement in the patient's general condition, and by expert



FIGURE 40.—Roentgenograms showing ureteral calculi in patient with complete spinal cord transection in middorsal region. A. Right ureteral calculus at level of lower border of sacroiliac joint. B. Retrograde pyelogram showing abnormal kidney and ureter above obstructing ureteral stone. The numerous filling defects are caused by inspissated pus. Right ureterolithotomy was done, with prompt recovery. C. Postoperative intravenous urogram demonstrating excellent anatomic and functional recovery by right kidney.

attention to foci of infection in other parts of the body, particularly pressure sores. A routine daily liquid intake of 4,000 cc. was an aid in the prevention of renal infection.

Stasis in the kidneys was combated by changes of body position every 2 hours. This could be accomplished without the use of a Stryker frame. A program of forced fluids also helped to avoid urinary stasis in renal calyces and pelves.

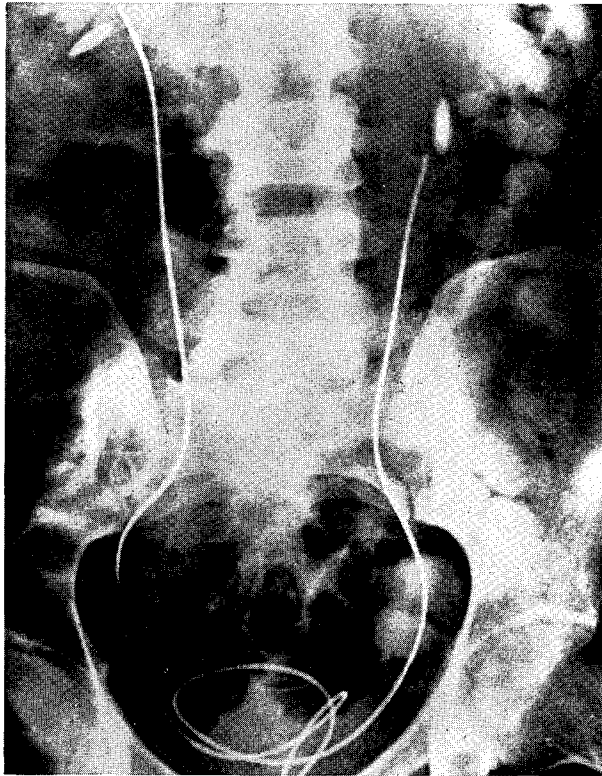

FIGURE 41.—Roentgenogram showing bilateral single calculi in patient with partial cauda equina transection. The stones were removed surgically. There was no recurrence of calculi during the next 6 months.

Hypercalciuria was very difficult to combat. There still appears to be no specific method of correcting it by dietary, hormonal, or drug therapy.

If calculous disease became established in spite of every effort, it was often possible to control it by surgery. The paralyzed patient tolerated renal surgery surprisingly well. In addition, as time passed and he became more ambulatory, if a clean removal of calculi had been done, the chances of recurrence decreased.

In the bedfast patient, calculi which were asymptomatic and not associated with fever or hydronephrosis were not considered immediately surgical. It was wiser, if possible, to wait until the patient was ambulatory before undertaking operative removal. Stones in the calyces do not require surgery. Occasionally, however, calculi obstructed the kidneys of a bedfast patient and operation was necessary for the patient's survival. The most efficient urinary antiseptics were not adequate to control infection under these circumstances.



FIGURE 42.—Roentgenogram showing multiple unilateral renal calculi in paraplegic patient, which increased appreciably in size over a period of 4 months.

In the ambulatory patient, surgery could be timed and planned to remove all calculi through one incision, before obstruction or dispersion of the stones into the ureter had taken place.

Conservative renal surgery was paramount in the paraplegic patient because of the greater than average possibility of stone formation in the opposite kidney. Kidneys which were widely and grossly infected, with multiple abscesses throughout the cortex, at times improved, and function was maintained when obstruction was relieved. The presence of calculous disease of the opposite kidney often contraindicated nephrectomy even when the infected kidney appeared gravely damaged.

These statements do not imply that nephrectomy was never done. When a normal kidney was opposite a large pyonephrotic kidney with a thin cortex, surgical judgment took precedence over rules.

Nephrostomy and irrigation with Suby and Albright's solution G proved helpful but was not universally successful. Prather's experience confirmed Bowie's finding that irrigation treatment by means of ureteral catheters is not successful.

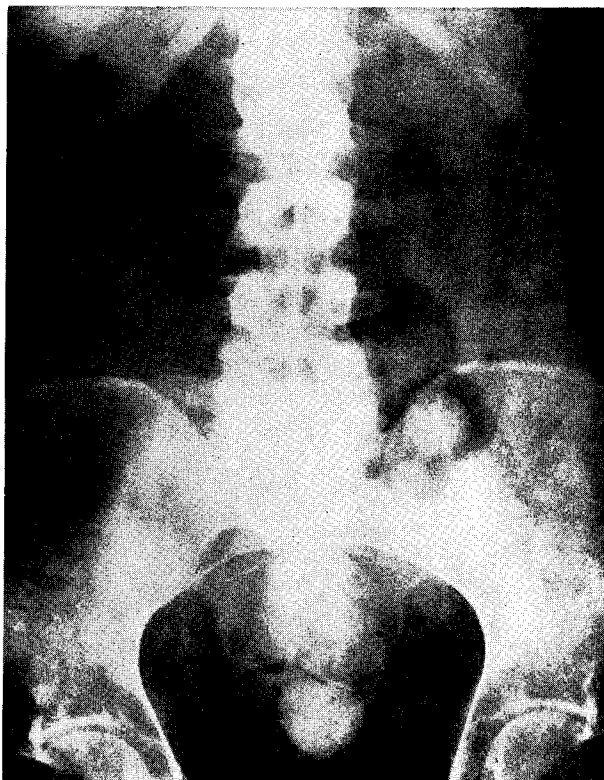

FIGURE 43.—Roentgenogram showing bladder stone in paraplegic patient with complete spinal cord transection in upper dorsal region.

Unless ambulation was enforced and strenuous efforts were made to eradicate infection, there was an appreciable recurrence of calculus formation. Recurrence in series of cases observed over periods of 5 to 12 months was otherwise not unduly large.

Calculous disease in combination with infection was a serious threat to the welfare of the paraplegic patient. The obstructing stone had to be removed if the urinary antiseptic agents were to exercise their full effect.

Ureteral Complications

Calculi.—Ureteral stones descend from the renal pelvis and occur in the paraplegic patient as they do in any other group of patients. The tendency of renal calculi to increase in size fairly rapidly and thus become too large to engage the ureter produced a higher ratio of renal stones to ureteral stones in military practice than in ordinary urologic practice.

The pain of ureteral colic was often absent in the paralyzed patient with a high level of anesthesia. Frequently, a febrile reaction called attention to obstructive pathologic changes in the urinary tract. The diagnosis was made by roentgenograms. Intravenous urography provided information concerning the degree of obstruction. When there was uncertainty about the nature of an opaque shadow in the course of the ureter, retrograde study, especially in the oblique position, was often necessary.

Treatment of ureteral calculi became a matter of keen judgment. It rested on estimating the probabilities of spontaneous passage versus manual dexterity, not only with cystoscopic instruments but with surgical measures. Calculi of passable size not causing a febrile reaction or more than minimal dilatation proximally were treated expectantly, in the hope that they would descend to the bladder spontaneously. Frequent roentgenologic examination was required to watch their progress. Cystoscopic manipulation under these circumstances was associated with a definite risk of infection above the calculus if the procedure was not successful.

Calculi considered too large to have a good chance of passing spontaneously, as well as those of borderline size responsible for a febrile reaction because of the infected kidney above, were removed by ureterotomy. Surgery, as already stated, was well tolerated by the paraplegic patient and provided a certain method not only of removing the stone but also of relieving obstruction. Ureteral incisions, like those in the kidney, healed at a normal rate, and fistula formation was uncommon. In an appreciable number of primary closures of the ureter, there was no urinary drainage from the wound after operation.

Bladder Complications

Infection.—Long-continued severe cystitis was likely to lead to a reduced bladder capacity, as observed by Head and Riddoch in World War I. These observers also found that any severe fever tended to disturb previously established reflex action. As Ware⁷⁸ had noted in 1918, it is entirely possible for a hypertonic, small-capacity bladder to develop within 3 months of injury.

Calculi.—Bladder stones were not a direct menace to the life of the paraplegic patient, but they interfered with establishment of satisfactory bladder

⁷⁸ Ware, M. W.: Contracture of the Bladder (Hypertonia Vesicae) Due to Spinal Injury. *Ann. Surg.* 67: 533-535, May 1918.

function and, by irritation of ureteral orifices, might be responsible for reflux or ascending infection.

The incidence of bladder calculi in military personnel with spinal cord injury was apparently uniformly high. Prather reported an incidence of 30 percent in patients with complete transection and of 14 percent in those with partial transection. These figures are comparable to those of Raines and Bowie, who reported, respectively, that 27 and 32 percent of their patients showed bladder calculi.

Stone formation occurred irrespective of suprapubic urethral catheter drainage and of tidal or manually controlled irrigation as well as during the use of solution M as the sole irrigating medium. In most instances the stones were small.

Symptoms were minimal, because the patients had little or no sensation in the bladder. The diagnosis was usually made by roentgenograms or by cystoscopy. Chemical analysis usually showed that the stones were chiefly composed of calcium phosphate and calcium carbonate.

The treatment of multiple small calculi in the bladder did not prove difficult. They could be crushed with the cystoscopic lithotrite and removed through the resectoscope sheath with the aid of the Ellik evacuator, or, at times, they could be removed through a suprapubic sinus.

Prostatic Complications

With the employment of urethral catheter drainage over a long period of time, prostatitis of some degree was probably universal in the paraplegic patient, but it seldom appeared to be of clinical significance. Since there was no good reason to examine prostatic secretion in these patients, no data are available.

Prostatic abscess was unusual even in patients on urethral catheter drainage for many weeks. Perhaps this immunity might be explained, at least in part, by the dilated prostatic urethra which is common in many of these cases. If the bladder neck and prostatic urethra are relaxed, secretions from the prostate emerging into the urethra would flow back easily into the bladder.

Complications in the External Genitalia

Epididymitis.—Infection in the epididymis may occur whenever there is urinary infection, presumably by retrograde extension via the ejaculatory ducts and vas deferens. Bloodborne infection is also possible, but, in general, it tends to cause abscess of the testis rather than of the epididymis. Epididymitis is more common during periods of bladder drainage by urethral catheter than by a suprapubic tube. These observations were all confirmed in paraplegic centers.

In the paralyzed patient, symptoms were negligible, but inspection of the swollen scrotum revealed the disease. Fever was common.

Treatment was the same as in the nonparalyzed patient. Elevation of the scrotum, which is an accepted procedure, helped to relieve pain in the patient who had sensory appreciation. Reverting to cystostomy drainage simply for this infection was hardly advisable once the inflammatory process had begun. Systemic use of sulfonamides and penicillin was logical and useful. Surgical drainage was necessary only if a fluctuant abscess occurred. In virulent infections, the process might cause extensive scrotal sepsis necessitating epididymo-orchidectomy.

Periurethral abscess.—Infection in the glands of the urethra might become severe enough in one area to lead to abscess formation. This occurred most frequently during periods of drainage by urethral catheter and was not uncommonly due to the use of too large a catheter. A large catheter was also apt to produce pressure necrosis at angular portions of the urethra and to cause abscess formation. In the paralyzed patient, catheters larger than No. 18 F. were found to enhance the probability of periurethral abscess. Abscess formation, which was most common at the penoscrotal angle, often caused sufficient inflammatory reaction to be momentarily confused with scrotal sepsis. Careful palpation led to the correct diagnosis.

The abscess itself was not serious, but if urethral fistula followed evacuation of pus, the recovery of the patient to a voiding state was delayed, sometimes by many weeks. Treatment of the abscess was by systemic agents, sulfonamides, and penicillin, with incision and drainage when required. A small, urethral catheter permitted intraurethral discharge of pus. As in epididymitis, cystostomy did not appear advisable once the process had become full blown, since a change to suprapubic drainage at this point does not prevent the formation of a fistula.

Urethral fistula.—Fistulas in the bulbous portion of the urethra tended to close more quickly than those of the penile urethra provided that there was no obstruction distal to the opening. They might close spontaneously in either area. If the fistula was small and spontaneous closure did not occur, fulguration of the sinus aided in the process. When the opening was larger, surgical closure by plastic methods was sometimes required, as described by Cordonnier.⁷⁹

Priapism.—Priapism as a reflex mechanism was common in patients with spinal cord injury, especially those with complete transection, after the stage of spinal shock had passed. It was usually recurrent, each episode lasting from a few minutes to several hours. The erection disturbed the adjustment of urethral catheters if adhesive-tape fixation had been used. Hartwell,⁸⁰ in 1917, noted priapism in 27 of a series of 67 patients with injury of the cervical or thoracic portions of the spinal cord; in all but 3 of the 27 cases, the patients had suffered complete transection.

⁷⁹ Cordonnier, J. J.: *Fistula of the Penile Urethra: A Method of Repair Utilizing Stainless Steel "Pull-Out" Sutures.* *J. Urol.* 55: 278-286, March 1946.

⁸⁰ Hartwell, J. B.: *An Analysis of 133 Fractures of the Spine Treated at the Massachusetts General Hospital.* *Boston M. & S. J.* 177: 31-41, 12 July 1917.

There is no specific treatment. At times, neurosurgical advice was requested concerning possible nerve section or block to overcome the condition.

Impotence.—Few data are available on this question, but it is a subject that needs study and evaluation. Cobb and Coleman found that, as a rule, sexual function suffered relatively more than urinary or rectal function in high lesions but that, in lower injuries, sex potency might return before control of bladder and rectum was regained. Impotence might exist even after partial transection and was of special concern to the male patient who had made a good recovery in respect to ambulation and bladder and bowel control. In Army experiences, the condition was more common following partial transection of the cauda equina than after a similar injury at a higher level. Further data are required to discover how much time is required for optimum recovery.⁸¹

RESULTS OF TREATMENT

An accurate survey of results of urologic treatment is difficult because in reported series, the distinction between partial and complete transection of the cord has not always been maintained and because several methods of treatment were often employed in one patient. The following statements should therefore be accepted with these reservations in mind.

In 1917, Thomson-Walker, who did not differentiate between partial and complete transection, found that 55 days was the average length of time for the first two stages of bladder recovery. His cases were treated by intermittent catheterization, and the mortality rate, as already mentioned was very high. Apparently, some of his patients later underwent cystostomy. In a series of 100 patients whose injuries were more than 2 years old, 69 had resumed voiding with an automatic reflex bladder. In those patients who had bladder capacities of 8 to 12 ounces, the residual urine varied between 0 and 6 ounces. Patients with larger capacity had a larger residual.

Riches reported on 30 patients studied in World War II in whom no single form of treatment was used. In injuries of the spinal cord, a period of 4 to 20 weeks (an average of 12 weeks) elapsed before voiding was resumed, while in injuries of the cauda equina, a period of 6 to 68 weeks (an average of 26 weeks) passed before voiding took place. Periodic reflex micturition developed best in supralumbar lesions, and the residual urine was seldom over 2 ounces. Of 20 patients with incomplete transection, 9 recovered voluntary control after intervals of 1 day to 15 months. The presence of a suprapubic tube for periods of 9 to 13 months did not prevent eventual return of micturition which was clinically normal except for the presence of infection and a 2-oz. bladder residual. Over a period of 2 years, the mortality rate was 28.5 percent, and half of the deaths were caused by urinary tract infection.

⁸¹ Studies on this point have been made in Veterans' Administration hospitals.

Dennis,⁸² writing in 1895, found that the higher the injury of the cord, the higher was the mortality rate. He cited the death rate in the Civil War for gunshot wounds of the cervical region as 70 percent, of the dorsal region as 63.5 percent, and of the lumbar region as 43.5 percent. Cumston,⁸³ in World War I, found a mortality rate of 32 percent in lesions of the cauda equina, considerably less than the death rate of 64 percent in injuries of the spinal cord. Riches, in 1943, reported a mortality rate of 62.5 percent in complete transection of the spinal cord and of 15.8 percent in complete transection of the cauda equina. In cases of partial transection of the cauda equina, the reported mortality rate was 12.5 percent as compared to 43.7 percent for partial transection of the spinal cord.

Up to the end of World War II, Munro⁸⁴ had reported the largest number of spinal cord injuries observed in civilian life. In 1943, he reported an overall mortality rate of 57.5 percent in 40 thoracic and lumbosacral cord and conus injuries. Deaths due to genitourinary sepsis were estimated as representing about 17 percent of the total deaths. Some of these deaths, however, were due to surgical accidents. In 100 cases of cervical cord injuries, the mortality rate was 46 percent, but genitourinary sepsis was responsible for only 6.5 percent of the total deaths.

Some interesting comparative data for tidal drainage were reported by Munro⁸⁵ in 1946. Infection of the genitourinary tract developed in 24 percent of a group of patients who were completely paralyzed below the waist while they were under treatment by this method, but it had cleared up in all but 8 percent before discharge. Infection was present at discharge, however, in 20 percent of a group in whom this method was not employed until other techniques had been used and was also present at discharge in 17 percent of a group of patients in whom it had not been employed at all. Sixty-nine percent of Munro's patients who had been treated exclusively with tidal drainage had no infection of the genitourinary tract at any time.

Functional results in 125 selected cases in Munro's series showed that complete urinary control was attained in 58 percent of the patients when tidal drainage was used from the start, in 45 percent when it was used after an interval, and in 79 percent when it was not used. Munro does not specify in what type of case the tidal apparatus was not used, nor does he state what type of treatment was used instead. The reasons for failure in cases in which tidal drainage was used were variable; they do not discredit this method and would contribute to the failure of any method. In a selected group of 101 cases, only 1 patient in whom tidal drainage was properly used for a sufficient length of time failed to have infallible 24-hour control of urination at the time of discharge.

⁸² Dennis, F. S.: *The Treatment of Injuries of the Spine and Cord by Sayre's Plaster-of-Paris Jacket*. *Ann. Surg.* 21: 268-278, 1895.

⁸³ Cumston, C. G.: *The Treatment of Cranio-Cerebral and Cord Injuries of Warfare*. N. York M.J. 109: 196-198, 1 Feb. 1919.

⁸⁴ Munro, D.: *Thoracic and Lumbosacral Cord Injuries; A Study of 40 Cases*. *J.A.M.A.* 122: 1055-1063, 14 Aug. 1943.

⁸⁵ See footnote 46(2), p. 93.

In 1936, after only a brief experience with tidal drainage, Munro⁸⁶ reported that the uninhibited normal cord bladder (automatic bladder) had a storage capacity of less than 200 cc. in 90 percent of cases and that the average residual was about 6 percent of the fill. End points of progress were reached between 17 months and 17 years after injury. There are no recent data by this author on bladder capacity, amount of residual, and rate of recovery in cases with complete transection of the spinal cord, now that many years of experience with tidal drainage have been acquired. A larger capacity may be inferred from his statement that patients can go a minimum of 3 hours during the day and for the entire night without wetting themselves. If one can assume a urinary output of 2,000 cc. per 24 hours, with 6 voidings at 3-hour intervals during the day and none at night, bladder capacity would be about 330 cc.

Petroff discussed the progress of patients injured in World War II at a symposium on the subject in 1945.⁸⁷ He had been able to transfer to tidal drainage 42.5 percent of 40 patients with complete transection who had had suprapubic cystostomy overseas. Reflex urination had been developed within a period of approximately 1 year from the time of injury. Patients with partial transection could, in general, be rehabilitated to a voluntary voiding status within 6 to 8 months from the time of injury.

Medler,⁸⁸ at a similar conference, reported that in 122 cases of partial and complete transection, two-thirds of the patients were free of catheters at a time presumably averaging 8 to 15 months after injury. Prather studied a series of 61 patients with spinal cord injuries. There were 2 deaths, in an average period of nearly 15 months from the time of injury, in 20 patients who had suffered complete transection of the spinal cord. One death was caused by general sepsis that included the urinary tract and the other by acute hepatitis. Periodic reflex voiding had been established in 62 percent of the patients without the use of tidal drainage or resection of the bladder neck. Micturition occurred at 1- to 4-hour intervals during the day, with a longer interval during the night. There was no leakage of urine during the interval between urinations. Bladder residual varied between 1 and 3 oz. Several weeks after rehabilitation of the bladder had been accomplished, the urine became grossly clear, but it still showed positive cultures in the majority of cases. These patients were ambulatory in wheelchairs or were on braces outdoors and indoors. Some took trips to surrounding towns via automobile.

Patients in whom voiding had not become reestablished either were in poor general condition from associated injuries or had not sufficient reflex bladder activity, as shown by cystometric study, to reestablish voiding. Those who had developed periodic reflex micturition did so within 3 to 10 months from the time of injury (an average of 5.77 months). After con-

⁸⁶ See footnote 9(2), p. 69.

⁸⁷ See footnote 73, p. 102.

⁸⁸ See footnote 72, p. 102.

version from suprapubic drainage, it was possible to develop an automatic bladder, with the suprapubic wound healed, within a period of 4 to 8 weeks. Most of these patients had had suprapubic cystostomy overseas. A manually controlled system of irrigation was used during both suprapubic and urethral drainage in the majority of the cases.

Forty cases of partial transection of the cord or cauda equina caused by war injuries were studied by Prather for periods up to 19 months from the time of injury. His personal study began after the patients had been evacuated to the United States. There were no deaths in this series. Thirty-nine patients resumed voluntary voiding in normal quantities and with nearly perfect control. Tidal drainage was used in only a few cases, and resection of the bladder neck was necessary in only one case. In the patients who had had urinary retention for 1 month or longer, the longest time from injury to resumption of voiding was 11 months, and the average period was 3 months. Fifteen percent had resumed voiding less than a month after injury.

Bumpus, Nourse, and Thompson's report on a series of 101 spinal cord injuries concerned naval personnel. They found it advisable to resect the bladder neck in 39 of 56 patients with injuries below the level of the eleventh thoracic vertebra. Following this procedure, satisfactory urination was established in all but three. They believed that the operation facilitated emptying of the bladder and contributed toward an eventual clear urine. They also used vesical neck resection to diminish or eliminate bladder residual in 16 patients with lesions above the tenth thoracic segment. In their series, there were two deaths. Of the surviving patients, 94 percent were free of catheter drainage, and in the majority, the urine was grossly clear. Negative urinary cultures were reported in 39 percent.

The data from these various sources indicate that urologic treatment of spinal cord injuries was far more successful during the period just before and during World War II than it had been 20 years earlier. Several factors were probably responsible. Wider knowledge of the ability of the bladder to recover its functional activity had led to more energetic and successful attempts at rehabilitation to a state of satisfactory voiding. The greater cleanliness of a sterile closed system of drainage and irrigation had helped to reduce gross bladder infection and prevent a certain number of renal complications. In addition, the more efficient urinary antiseptics saved lives and contributed to eventual recovery. In World War II, the paraplegic patient was justified in looking forward to bladder function that would permit a reasonable social existence.

Influence of Level of Treatment on End Results

The level as well as the extent of the spinal cord injury determines to some degree the final status of the bladder and the success of the long-term program of rehabilitation.

Patients with complete cervical transection present special difficulties in

rehabilitation of the bladder because they cannot use their hands. Since they are unable to use a urinary receptacle, they are sometimes best left on suprapubic drainage. If, however, a partial transection in the cervical region is unilateral, the patient can handle a urinal satisfactorily and should look forward to a normally functioning bladder under excellent voluntary control.

Patients with complete transection at the level of the upper and middle thoracic segments have an excellent chance of developing an efficient, socially compatible, reflex type of bladder as an end result. The intervals between voiding may reach several hours, and, during the intervals, no leakage of urine should occur. In the supine position, a bladder capacity of 4 to 8 oz. is to be hoped for. In the sitting position, a larger amount of urine may accumulate before a reflex contraction takes place. A bladder residual of 1 to 3 oz. is not uncommon. Patients with partial transection at this level should attain an efficient bladder with voluntary control.

In cases of complete transection at the level of the lower thoracic or lumbar segments, the establishment of an automatic bladder is less certain. There are, however, a number of reported instances in which very satisfactory reflex function has become established. Bladder capacity is usually greater than with complete lesions at a higher level, and a longer interval between voiding can be anticipated if, at the time of reflex contraction, supplementary effort by straining or suprapubic pressure is used. These methods may help to avoid a tendency toward a larger bladder residual than is commonly found in higher lesions.

Patients with complete transection at the level of the cauda equina are unlikely to progress to an efficient type of automatic bladder, although Denny-Brown⁸⁹ reported cases in which it had been achieved. Munro,⁹⁰ however, found an inefficient autonomous bladder the typical end result. In such instances, the bladder with an appreciable bladder residual is best cared for by permanent drainage if voluntary straining and abdominal pressure do not produce satisfactory emptying.

Partial lesions of the cauda equina may be associated with some incontinence when the patient is standing or engaged in physical activity. During attempted urination, some straining may be necessary to empty the bladder.

SPINAL CORD INJURY IN THE FEMALE

Lack of wide experience with females with this type of disability prevents authentic statements for this group. The progress toward recovery should be the same, however, and the chance for urethral and genital complications less. During the early phases of the illness, it would seem imperative to use a balloon-type catheter for drainage with either manual or auto-

⁸⁹ See footnote 11, p. 71.

⁹⁰ See footnote 9(2), p. 69.

matic irrigation to prevent overflow incontinence, a wet bed, and decubitus ulcers. Rehabilitation to a satisfactory voiding state should be possible.

MILITARY POLICIES

Although complete data are not available, some information in regard to the urologic problems of paraplegic patients can be summarized.

Historical Note

Not much information is available concerning spinal cord injuries in World War I. Cushing set the mortality rate at 80 percent.⁹¹ There was no definitive program of management (p. 4), and only casualties with partial cord injuries seem to have survived.

According to Young,⁹² nonintervention was generally believed to be the wisest course, and the Manual of Military Urology,⁹³ for which he served as chief editor, recommended this policy. He had no information on how successful this policy had been, but he stated that, in many cases, it was apparently desirable, or later became essential, to employ catheterization or suprapubic drainage. Connors and Nash, in a survey of the policies of the various combatants in World War I, found that the British, like the U.S. forces, had never issued definite orders or instructions regarding treatment. The French Army apparently used catheterization early and cystostomy later. Inquiry of German and Austrian sources was unproductive, the replies stating that there were no statistics on the problem and no preferred method of treatment.

Evolution of Policies in World War II

At the beginning of World War II, there was no official policy regarding the urologic management of spinal cord injuries. This is readily explained. Probably in no other type of injury were such divergent opinions concerning the proper or best treatment so positively expressed by so many authorities. Different methods of handling the bladder in civilian spinal cord injuries had been championed and denied with equal vigor by recognized urologists and neurosurgeons. Experiences in World War I, while they had failed to indicate any ideal form of treatment, had demonstrated that the program of intermittent catheterization led to an appalling mortality. It is therefore understandable that, in this confusion, no official policy could be honestly advocated. Tidal drainage had been the only new form

⁹¹ Cushing, H.: Organization and Activities of the Neurological Service, American Expeditionary Forces. In *The Medical Department of the United States Army in the World War*. Washington: Government Printing Office, 1927, vol. XI, pt. 1, pp. 749-758.

⁹² Young, Hugh H., and Davis, David M.: *Young's Practice of Urology*. Based on a Study of 12,500 Cases. Philadelphia and London: W. B. Saunders Co., 1926, vol. II, p. 695.

⁹³ *Manual of Military Urology Including Venereal Diseases, Skin Diseases and Wounds of the Genito-Urinary Organs*. Published for the American Expeditionary Forces by the American Red Cross. Paris: Masson et Cie., 1919, 2d ed.

of treatment prescribed in the previous 10 years, but care of war casualties usually prohibited the use of this system until the patient reached a well-equipped fixed installation. Furthermore, relatively few physicians were acquainted with this apparatus, its intricacies, and the cystometric studies necessary for its correct use. In addition, associated wounds of the chest or abdomen often prohibited the immediate use of this favored treatment.

Management overseas.—In spite of the known difficulties, much thought was given to formulating a program of management of these casualties, particularly in the European theater, and long before D-day. Instructions were issued just before the invasion date, specifying that tidal drainage should be used. It was thought that rapid air evacuation from the Continent to England would facilitate this plan, and, for some months, paraplegic patients sent from France to England were all treated by tidal drainage on the Continent.

Gradually, however, patients began to be returned with suprapubic tubes. As reported by Scarff, this was due to several factors:

* * * primarily to the advent of new armies in the theater—for instance, the 7th, the 9th, and the 15th. Parts of the 7th Army had fought in the African desert and in the Italian mountains and their unique experience in these difficult terrains undoubtedly justified their belief that the suprapubic drainage was the only safe method. Others simply had not come under the persuasion of the Chief Surgeon's staff and had evolved their own doctrines, in which the immediate safety of the patient completely obscured the long-term objective of his later rehabilitation.

The lengthening lines of communication, delay in prompt evacuation because of adverse weather, and changing personnel finally made continuance of the tidal drainage program impossible.

Between D-day and V-E Day, 1,260 paraplegic patients were treated in general hospitals in the United Kingdom Base alone. The ideal care, according to the senior consultant in neurosurgery, consisted of transporting the paraplegic patient from the battalion aid station to the nearest collecting station, then sending him in an ambulance to the nearest evacuation hospital, where his general condition could be evaluated and he could be prepared for prompt air evacuation to a neurosurgical center. Insertion of an indwelling catheter was the only urologic measure advised at this stage. For various reasons, including other wounds, only about 50 percent of the casualties could be handled in this manner. The remainder had to be cared for in evacuation and field hospitals for the first 2 or 3 weeks after injury.

Once the patient arrived in a general hospital, he was placed in a special ward, of which a urologist was in charge. The care of the bladder was considered the most urgent problem. In some of the centers, tidal drainage via the urethral catheter was used for several weeks. At the end of that period, if there was no return of spinal cord function, a suprapubic cystostomy was performed, to facilitate immediate treatment of urinary sepsis and to make the patient ready for evacuation to the United States in the shortest possible time. When the wound had healed well around the supra-

pubic tube and urinary sepsis had subsided, he was considered ready for evacuation from a urologic point of view. It was not feasible to use tidal drainage continuously in an active theater of war in a large group of casualties. Furthermore, it was completely impractical during the trip to the Zone of Interior by any form of transportation.

The neurogenic bladder was one of the most common types of urologic dysfunction that confronted the urologist in modern warfare, and its management remained a debatable subject to the end of hostilities. No conclusions could be drawn concerning whether or not tidal drainage irrigation was essential because statistics on parallel groups of identical injuries were not available. Nor could conclusions be drawn concerning the relative merits of various irrigating fluids used in tidal drainage, though acid mediums appeared to be the most valuable. Of 117 patients observed by Maj. (later Lt. Col.) John N. Robinson, MC, in whom the extent of the lesion was not specified and who were treated with tidal drainage, 50 percent had some degree of return of bladder function. Of a group treated by catheter drainage in which tidal irrigation was not used, 31 percent had a comparable return of vesical function. Of another group of 294 patients, 199 required suprapubic cystostomy either because of early recognition of a hopeless lesion or because of failure to respond to urethral drainage. Robinson found that patients who experienced marked or complete improvement showed it within 3 weeks. He believed that suprapubic cystostomy after that time appeared to be the logical therapy either to insure safety during evacuation or because of a poor ultimate prognosis. Lt. Col. J. Hartwell Harrison, MC, in the Southwest Pacific Area, found that the best results were obtained when early continuous tidal drainage was instituted by urethral, perineal, or suprapubic catheter. It was not possible to use the urethral catheter in many patients until an automatic bladder had been established, and a few, even with the best of care, did not tolerate it. For transportation over long distances by air or water, the suprapubic catheter proved to be the easiest to care for and the safest method of drainage.

Suby and Albright's solution was used for irrigations. Progress toward automaticity was followed by biweekly cystometrograms.

Additional personnel were assigned for handling spinal cord injuries, and with the care thus made possible, patients under the regimen described did not develop renal or vesical calculi, and automatic bladders were established before evacuation in one-third of the cases.

Management in the Zone of Interior.—After arrival in the United States, which was usually 6 to 12 weeks after injury in the European theater, paraplegic patients were sent to neurosurgical centers located in Army general hospitals. The trip from overseas, whether by air or by ship, had often been an arduous one.

Thorough reevaluation of the urinary tract by roentgenography, intravenous urography, cystometry, and cystoscopy was instituted, and the general measures described were continued.

Capable representatives in various special fields, such as neurosurgery, orthopedic surgery, plastic surgery, nursing, dietetics, physiotherapy, occupational therapy and recreation, Red Cross, and the Chaplain Corps, were also enlisted for the welfare of these casualties. Their rehabilitation became a challenge in many fields of medicine.

The urologic program was at first left to the ability, ingenuity, and resourcefulness of the urologists at the centers designated for the care of the paraplegic patient. Organized and improved urologic treatment became increasingly necessary, however, as the number of patients increased. Sterile closed systems of drainage and irrigation were instituted in some centers. Cystometric studies disclosed that many bladders were capable of resuming function, so that it was possible to institute urethral catheter drainage with a closed system of drainage while the suprapubic wound healed. Attention was also given to obtaining a renal condition as near normal as possible. The final steps, removal of the catheter, a training period for the bladder, and either reflex or voluntary voiding, proved successful in many cases. This improvement was not accomplished overnight, but, during a period of months, excellent results were obvious and stimulated further effort.

A survey of paraplegic patients in October 1945 revealed that 948 of 1,430 paraplegic patients had arrived in the Zone of Interior with suprapubic tubes in situ and that 236 of these, almost 25 percent, were voiding on arrival. At the time of the survey, 635 patients, almost 44 percent, had reestablished bladder activity and were voiding. Of 642 patients presumed to have complete transections of the cord, 29 percent were voiding periodically with an involuntary reflex type of bladder activity, 32 percent were on urethral drainage, and 39 percent remained on suprapubic drainage. Of 750 patients presumed to have partial transection of the spinal cord, 65 percent were voiding with voluntary control. These averages, which of course do not represent the final accomplishment or the end point in the rehabilitation of the bladder, indicate that commendable progress had been made in these cases within a period of months after the injury.

The survey produced further interesting clinical and statistical data. Fifty-six cases of periurethral abscess were found, 48 of which occurred during urethral catheter drainage. One hundred and seventy-nine instances of epididymitis were recorded, 126 of which occurred during urethral catheter drainage.

Urinary tract calculi proved to be an important potential or actual complication. At the time of the survey, more than 12 percent of the patients had renal calculi, and at least 20 percent had vesical calculi.

Drugs had not proved helpful in promoting bladder activity.

Resection of the presacral nerve was reported in two cases; both operations were failures. Resection of the bladder neck to facilitate emptying of the bladder had been tried in 33 cases up to this time, with good results in 19 and poor results in 14.

Inquiry among the urologists on duty at neurosurgical centers yielded the following opinions: Twenty believed it advisable to aim for resumption of voiding in the paraplegic patient, and only two did not believe the effort worthwhile. Nine believed tidal drainage was necessary for the eventual rehabilitation of the bladder, but sixteen disagreed with that opinion. Twenty-three advocated cystometric study periodically to determine the status of the bladder, although three did not believe this type of examination helpful.

The mortality rate in spinal cord injuries in active theaters of war was not yet known at this time (October 1945), nor was the mortality rate known in patients who had survived the initial shock of injury and had been returned to the Zone of Interior. Scattered reports from neurosurgical centers in the United States indicated a remarkably low mortality rate during the first year, probably not over 6 percent, in this group; all the deaths, furthermore, were not due to urologic causes. Patients who were not discharged to their homes would eventually be transferred to Veterans' Administration hospitals for further care, and statistical data must necessarily come from that source (p. 12(n)).

A SUGGESTED PROGRAM OF MANAGEMENT

The following suggested program is based on an academic review of contributions of many authors and on experiences in the rehabilitation of patients during World War II. It is believed that it is as errorproof as possible and that it will lead to a urinary tract as functionally efficient as the extent of the injury allows. A successful result, as just indicated, depends as much on the skill and attention of those in immediate charge as on the several possible methods of treatment.

There appears to be no reason to catheterize the bladder until urinary retention has been demonstrated. When, however, it becomes evident that the bladder will not immediately resume function, the patient should be catheterized under strict aseptic precautions with a No. 18 F. two-holed soft rubber catheter. The catheter should be arranged for constant drainage and connected to a sterile closed drainage system with provision for closed irrigation controlled either manually or automatically.

If the neurosurgical survey indicates that a partial transection of the spinal cord has occurred, plans can be made to continue the urethral catheter program with the hope that voluntary bladder action will be reestablished in a period of weeks. If the survey indicates that there is complete transection of the spinal cord, the urethral catheter program can be continued unless contraindications appear, or suprapubic cystostomy can be done and the tube connected to a closed drainage system. In cases of complete transection, a number of weeks may elapse before a reflex type of bladder is established. With either the urethral or suprapubic drainage program, frequent irrigations under aseptic conditions must be used, and catheters or

tubes must be changed periodically before they become obstructed or encrusted.

Fluid intake and output must be maintained at a high level and the general state of nutrition watched carefully.

Routine tests of renal function, as indicated by blood chemistry studies and phenolsulfonphthalein excretion, should be made and repeated at intervals to be determined. Cystometric determinations should also be recorded at intervals of 1 to 2 weeks to note progress of recovery of bladder musculature.

Urinary studies, including cultures, should be made frequently. Roentgenologic study of the urinary tract by intravenous pyelography should be done as soon as practicable and repeated at intervals of several weeks.

Sulfonamides and antibiotic agents need not be used routinely but are helpful if upper urinary tract infection occurs. If urinary infection is present, urinary antiseptics should be used vigorously after bladder drainage has been terminated.

As soon as ambulation has been achieved or is in immediate prospect and the bladder shows a satisfactory cystometric response, measures must be undertaken to accomplish satisfactory voiding.

If voiding is not resumed as might be expected by the findings on combined urologic and neurologic examination, cystoscopic study of the bladder and bladder neck is justified. If there is evidence of vesical neck obstruction when neurologic improvement has reached a maximum, resection of this region should be considered.

A sincere interest in the welfare of the patient, strict attention to aseptic conditions, and an understanding of the aims of treatment on the part of the medical and nursing staff are essential for progress.

CONCLUSIONS

From the experiences in World War II, certain facts concerning urologic care of spinal cord injuries in war become apparent, as follows:

1. The soldier with paralysis of the bladder should have constant bladder drainage by means of a No. 18 F. urethral catheter connected to a sterile closed drainage system during the early part of his illness. Frequent irrigation of the bladder is important and can be accomplished by a tidal apparatus or by manual control.

2. If neurosurgical survey indicates a partial transection of the spinal cord, urethral catheter drainage can be maintained with hope of recovery of bladder function in a period of weeks.

3. If neurosurgical opinion indicates a severe injury with probable complete transection of the spinal cord, and if transportation over long distances is necessary, a high suprapubic cystostomy with manual irrigation by means of a sterile closed system offers a safe program.

4. Tidal drainage is a good method of bladder irrigation but is not necessary for rehabilitation of the bladder to a satisfactory voiding state.

5. Resection of the bladder neck may aid selected patients to reestablish voiding.

6. Renal surgery is necessary at times to save life and to prevent deterioration of renal substance.

7. Roentgenologic study of the upper urinary tract by means of intravenous urography at intervals of several weeks is advisable to interpret possible febrile episodes properly.

8. Cystometric study is necessary periodically to determine the proper time to aim for rehabilitation of the bladder.

9. Penicillin, streptomycin, and the sulfonamides are helpful in controlling urinary infection.

10. Cleanliness, gentleness, and personal ability remain important factors in urologic technique and treatment.

11. The aim of treatment should be reestablishment of the bladder as a satisfactory functioning organ. This objective can be accomplished in the majority of cases.

CHAPTER VII

The Management of Paraplegic Patients in Zone of Interior Hospitals

Barnes Woodhall, M.D.

The care of paraplegics in civilian hospitals before World War II had been conspicuously bad. In previous wars, the care provided for them had been even worse, partly because of the circumstances and partly because the care was based on an attitude of total defeatism (p. 3).

How completely the situation changed before World War II ended is indicated in a statement by the consultant in neurosurgery, Office of the Surgeon General, March 1945, as follows: "We have the problem of taking care of broken backs in much better shape. Indeed, for all practical purposes, we have it mastered. We simply were not aggressive enough, either mentally or physically, at first. Now we are."

The story of how this problem was mastered is contained in this chapter, in which the practical details of the paraplegic program are described and the concept on which it was based is set forth. The material is derived, unless otherwise indicated, from the reports of the conferences held at Newton D. Baker General Hospital, Martinsburg, W. Va., on 11-12 May 1945; Hammond General Hospital, Modesto, Calif., on 24-25 June 1945; Halloran General Hospital, Staten Island, N.Y., and Thomas M. England General Hospital, Atlantic City, N.J., on 19-20 October 1945; and the special session on war wounds of the spinal cord held at Newton D. Baker General Hospital on 20 June 1945 (p. 6).

ANALYSIS OF CASES

No comprehensive analysis of patients with paraplegia was undertaken in the course of the war, but a great deal of information of a general character was obtained in the questionnaire sent out from the Office of the Surgeon General in December 1945 (p. 14). The detailed replies concerned 1,399 patients, probably more than 70 percent of all paraplegics treated in Army hospitals in the Zone of Interior in World War II. The information which follows was summarized from those replies.

Cause of injury.—No information was requested in the original questionnaire concerning the cause of injury, but a supplemental study included in the report indicated that accidents were a more important cause of para-

plegia than of peripheral nerve injuries, the respective proportions being 21 percent and 4 percent. Shell fragments or shrapnel accounted for 40 percent of the spinal injuries against 62 percent of the peripheral nerve injuries and gunshot wounds for 35 percent of the spinal injuries against 26 percent of the peripheral nerve injuries. These figures were secured in an analysis of 114 paraplegics at Halloran General Hospital. A survey of 26 paraplegics at Percy Jones General Hospital, Battle Creek, Mich., showed that accidents were chiefly caused by traffic accidents, falls, and dives into shallow water.

Branch of service.—In 64 paraplegics studied at Halloran General Hospital, 86 percent were in the Army Ground Forces, 11 percent in Army Service Forces, and 3 percent in the Army Air Forces. About 80 percent of Army personnel were in the infantry. According to the Adjutant General's Office, 89 percent of all men in service during World War II were in the Army Ground Forces, 8 percent were in service forces, and 3 percent in Army Air Forces. For the Army as a whole, the infantry accounted for 90 percent of all personnel.

Age.—The median age of paraplegics was 24 for enlisted men, and the first quartile was 21. These age averages are about a year below the Army average. Only 17 percent were above 30 years of age, against 24 percent for the entire Army. A survey of paraplegic officers gave about the same results, except that the percentage of older paraplegics was less than the Army proportion of older men. The explanation was assumed to be the high proportion of paraplegics wounded in action, a group composed chiefly of younger men.

Rank.—Officers composed 8.2 percent of the paraplegics surveyed. At V-E Day, officer personnel accounted for 9.3 percent of Army strength. The explanation, again, is the high proportion of younger men in the paraplegic group and the very small number of Army Air Force personnel in it.

Marital status.—About a third of the paraplegic patients were married, against 44 percent for the entire Army. The explanation was the high percentage of younger paraplegics and their prolonged absence overseas. About half of the married paraplegics had children; 70 percent had 1 child each, and 2 percent had 4 children each.

Occupation.—In 3 percent of the paraplegics, no information was secured about occupation. Mechanics made up 26 percent, farmers 14 percent, clerks and students 11 percent each, salesmen 4 percent, and professional personnel 2 percent. The remainder represented a wide variety of other occupations. Comparable Army data, which were incomplete, showed that 12 percent of the personnel were farmers, 13 percent clerks, 13 percent salesmen, 5 percent students, and 4 percent professional men. The youthful age of the paraplegics is, again, the explanation for the small percentage of professional men in the paraplegic group. The high percentage of farmers might reflect selective factors in their background which resulted in their greater utilization in the infantry than in other branches of service.

Educational level.—Only 2 of the 1,399 paraplegics analyzed in this survey had had no schooling at all. In 3 percent, the educational level was not specified. Of the remaining patients, 3 percent had had from 1 to 4 years of schooling, 24 percent from 5 to 8 years, 56 percent from 9 to 12 years, and 11 percent from no college training at all to up to 3 years. The remaining 3 percent had had 4 years or more of education at and above the college level. Twenty-seven percent of the paraplegic group had failed to reach high school, against 35 percent for the entire Army, and 14 percent had attended college, against 12 percent for the entire Army. The explanation of these discrepancies is probably that paraplegics were both younger and more competent, as shown by the fact that so many of them had qualified for oversea service.

Army General Classification Tests.—No information was available on the results of the AGCT (Army General Classification Tests) for 23 percent of the paraplegics, including the 8 percent who were officers. In the order of descending achievement, 5 percent of the remaining paraplegics were in group I, 22 percent in group II, 24 percent in group III, 24 percent in group IV, and 2 percent in group V. These are, on the whole, higher scores than for the Army as a whole; on the basis of ten million examinations given at reception centers, 5.8 percent of all selectees were in group I and 8.8 percent in group V. Many paraplegics who did not go beyond high school had scores equal to, or superior to, the college group.

PRELIMINARY AND CONTINUING EXAMINATIONS

A complete history was taken, and a complete physical examination was made as soon as paraplegic patients were received in Zone of Interior neurosurgical centers. Routine laboratory tests included urinalysis and urine culture; blood studies, including a hematocrit determination; the Kahn test; blood chemical determinations, including nonprotein nitrogen, urea nitrogen, and creatinine; calcium and phosphorus determinations; determinations of the serum protein; and roentgenograms of the chest, spine, and urinary tract.

Orthopedic and genitourinary consultations were requested when these examinations were completed, and other consultations were requested on special indications.

Urinalysis was repeated twice weekly. The pH of the urine was determined every second day. Cultures of the urine were taken routinely once every 4 weeks, and oftener if necessary. Cystometric studies and sphincterometric studies were carried out at the same intervals. The blood chemistry was determined at least once every 6 weeks.

Roentgenologic practices differed from hospital to hospital. In one sense, it seemed wasteful to repeat these examinations in the absence of special indications. The general opinion was, however, that repeated roentgenograms were justified to determine bony changes and to guard against the insidious development of calcification, calculi, and osteoporotic changes.

The simplest way for the ward officer to keep close track of his paraplegic patients was by means of a chart, in tabular form (fig. 44), showing the name of the patient, the date and level of injury, and the dates of laminectomy and of suprapubic cystostomy. Frequent entries on this chart kept the medical officer responsible for the patient fully informed of his status and progress.

	NAME	DATE INJURY	LEVEL OF INJ.	DATE LAMIN.	DATE * SUPRA.	DATE * URETH.	SORES	BOWL	CYSTO-METRIC	KUB	COMPLICATIONS & REMARKS
1											
2											
3											
4											
5											
6											
7											
8											
9											
10											
11											
12											
13											
14											
15											
16											
17											
18											
19											
20											
21											
22											
23											
24											
25											
26											
27											* DATE STARTED
28											

FIGURE 44.—Control board in ward office for charting of data on all paraplegic patients on ward.

DECUBITUS ULCERS

The defeatist attitude toward gunshot injuries of the spine and their residuals evident in World War I and in the early months of World War II extended to all phases of their management, including the management of decubitus ulcers. Maj. (later Lt. Col.) J. Lawrence Pool, MC, and Capt. (later Maj.) Donald D. Matson, MC, who were among the first to adopt a more hopeful attitude in regard to the entire problem, directed particular attention toward this phase of it. These ulcers had been a serious problem in World War I in the patients who had survived their acute injuries for any length of time. In World War II, because of geographic considerations and the long distances over which transportation of these casualties was necessary, the problem was even more serious.

General Considerations

There was general agreement that the great majority of the paraplegic casualties received from overseas in World War II arrived with decubitus ulcers, which frequently were multiple as well as extensive. Of 21 patients treated during one period by Capt. (later Maj.) Donald E. Barker, MC, at Newton D. Baker General Hospital, 10 had 1 ulcer, 5 had 2, 4 had 3, and 1 had 5. The size ranged from a lesion 1 by 2 inches in extent to a lesion 6 by 8 inches, which covered the entire area of the sacrum.

Decubitus ulcers were observed in paraplegics on every body surface subjected to ischemia for periods of time sufficient to initiate cellular necrosis. At first, the upper limits of presumed safety were estimated rather liberally. As the war progressed, these limits were set at a maximum of 4 to 6 hours, with the shorter interval regarded as safer. It was also realized that the presumed safety of these time limits depended upon a number of factors in addition to the mere passage of time. Chief among these factors were repetitive ischemia and the systemic changes brought about by malnutrition and infection. Ulcers were occasionally observed in patients in good general condition, who had been well handled, and in whom they had developed in spite of every precaution. Most often, however, they occurred in cachectic, very ill patients, in whom inept handling had often compounded the predisposing circumstances.

Decubitus ulcers were observed on the heels; on the dorsum of the toes; and over the tibia, patella, sacrum, trochanteric region, ischial tuberosity, anterior superior iliac spines, spinous processes, alar scapulae, anterior chest wall, and olecranon. They were also occasionally observed over the forehead and malar prominences. Ulcers over the sacrum and in the trochanteric region, in which they were frequently bilateral, were of the greatest practical importance, both because of their frequency and because their correct treatment often required complicated plastic procedures. Small ulcers in these areas could often be closed by suture, but large ulcers might require extensive plastic operations, which were the more difficult to perform because of various degrees of subcutaneous invasion by the ulcerative process, and, in some cases, because of osteomyelitis of the sacrum or femur.

The pathologic process included engorged venules, thrombosis of the smaller veins, and thickened arterioles. Capillary thrombosis was manifested clinically by the absence of blanching on pressure. The bacteriologic flora was similar to that of the feces and urine.

Care During Transportation

Paraplegic patients were evacuated from overseas theaters to general hospitals in the Zone of Interior as soon as their condition permitted. The global extent of World War II made transportation necessary over great

distances, by whatever method of evacuation was available and practical, including rail, sea, and air transport.

It is a distressing historical fact that during most of the war, paraplegic patients arrived in the Zone of Interior considerably the worse for the journey (figs. 45 and 46). No authentic observations are available covering



FIGURE 45.—Paraplegic patient showing wound of entry, over-sea laminectomy scar, ill-defined level of cutaneous anesthesia, indicated by area of skin discoloration, and decubitus ulcers secondary to transportation.

the period of transportation, but the general criticism may justifiably be made that the high excellence of professional care behind the lines overseas and the similarly high excellence of professional care of these patients in Zone of Interior hospitals were not duplicated between these areas. Transportation, as far as paraplegics were concerned, was characterized by a dismal hiatus in treatment. The circumstances were particularly unfortunate for men with injuries of the spine, whose care must be incessant and unremitting.

In spite of the fact that in most gunshot wounds of the spine, the bony skeleton was relatively stable, protection of the vertebral column during transportation outweighed all other therapeutic considerations during the first months of U.S. participation in World War II. Many additional months were to pass before there was a full appreciation of the relevancy of the already well-established fact that decubitus ulcers develop as the result of ischemia of skin surfaces under pressure, whether or not analgesia is present. The paraplegic patient, who was unable to recognize pressure and unable to move even if he was aware of it, was naturally the better for

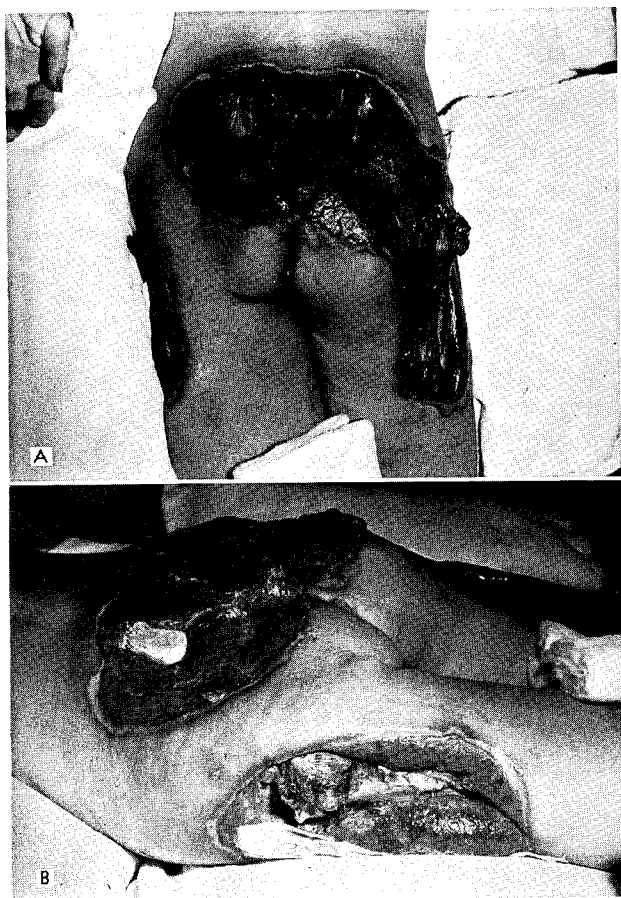

FIGURE 46.—Extensive decubitus ulcers in cachectic paraplegic patient. A. Posterior view. B. Oblique view. Note sequestration of head of femur.

care during transportation. If he did not receive it, he was simply the victim of adverse circumstances.

Eventually, it was realized that decubiti would inevitably occur unless certain measures were employed during transportation, as follows:

1. The position of the casualty must be changed during transportation at least every 4 hours and oftener if possible. This was mandatory.
2. During the intervals between changes of position, which were periods of potential ischemia, pressure points must be protected.
3. Body surfaces must be constantly protected from the macerating effects of body excretions.

The whole problem of the transportation of paraplegics was discussed in detail at the paraplegic conferences. Particular attention was devoted to it during the June 1945 conference at Hammond General Hospital, at which

it was pointed out that if ever casualties of the war deserved priority in transportation, it was these paraplegics. It was also pointed out that rapid transportation had other desirable effects in addition to the prevention of decubitus ulcers. One of them was the elimination of the period of debilitation and muscle wasting almost inevitable when transportation was by sea or by slow train.

On the other hand, every speaker at this and other conferences emphasized that air travel in itself was no solution to the problem, particularly if patients brought from overseas by plane were transported by train across the United States, as some of those in hospitals in the Ninth Service Command had been. In the absence of trained attendants, who understood the care of these patients, bedsores would develop, no matter what mode of transportation was employed. These attendants, whether they were nurses, medical officers, or technicians, had to understand that these patients must be turned regularly, that care of the bladder was necessary, and that the skin must be kept clean and dry. Skin care offered special difficulties in the tropics in patients who were in casts.

The entire problem of transportation of paraplegics had many ramifications. It was pointed out in discussions at the conferences, for instance, that they traveled better in Stryker frames and could be turned in them much more easily than in any other device. The use of these frames, however, was not practical because they were cumbersome in the limited space of the plane, and they added considerable extra weight. One proposal was that engineers in the Army Air Corps devote some attention to the development of a lightweight stretcher which could be used for the transportation of paraplegics and in which they could be turned easily. It was suggested that unless a Stryker frame was used, these patients should travel in the prone position, in which less cord damage was likely. Another proposal, that a number of specially built planes—up to a dozen—should be reserved for paraplegics, was regarded as unrealistic because the total number of these patients was very small. A more practical suggestion was that all paraplegics be tagged, just as patients receiving penicillin were tagged, with the instructions that they be turned every 2 hours.

Prevention

The prevention of decubitus ulcers was an objective never fully achieved, but the elements of prophylaxis were finally appreciated. The important measures consisted of (1) rapid transportation, as soon after injury as feasible, to a permanent hospital installation in the Zone of Interior, and (2) the segregation of patients for transportation under the care of specially trained air evacuation personnel, who were adept in turning paraplegics, in the care of the bladder, and in the other prophylactic and therapeutic measures of which paraplegics were in constant need.

In the last months of the war, when these principles had been realized and implemented, paraplegics often were received in Zone of Interior hospitals 60 hours or less after injury, and without decubitus ulcers, because they had been transported in appropriately padded casts, under the care of specially trained aircrews. It was reported at the Hammond conference in June 1945 that at DeWitt General Hospital, Auburn, Calif., patients who had arrived within the past month were already ahead of patients with equivalent lesions who had arrived a year earlier. One reason for the improvement of the patients who had recently arrived was that the hospital was now more fully prepared for the management of these patients than it had been then, but another, extremely important, reason was that they were transported faster, before deterioration of their status could occur and before bedsores, if they developed at all, could become extensive.

Management

While certain general principles of management were applied in all cases of decubitus ulcer in paraplegics, individualization of the patients was the rule in all centers, the regimen of therapy employed being fitted to the necessities of the special case. Careful records were kept of all lesions, including serial measurements and serial photographic records.

The protein deficit in decubitus ulcers, which played such an important role in their perpetuation and the correction of which was an essential phase of their management, is discussed under a separate heading (p. 147).

General care.—At many of the centers, it was the practice to nurse paraplegics on Stryker frames (figs. 47 and 48), which facilitated turning them. Otherwise, they were cared for on soft beds, on soft sheets kept free of wrinkles. There was no contact with rubber mattresses or other irritants.

The patient was turned every 2 hours. Daily baths were the rule, with more frequent bathing if necessary. The skin was kept dry and free of contamination from bodily excretions. Washing with green soap followed by ether was satisfactory. Dressings were usually sufficient to isolate the lesion from urine and feces. Alcohol rubs and massage were given at least every 4 hours.

The skin was protected from pressure at points of predilection. Pillows were more useful for this purpose than rings, which were usually made of cotton batting or were inflated by air. In either event, their resiliency promptly disappeared, and it was not very long before they were furnishing no protection at all against pressure.

Local measures.—The first phase of active therapy in decubitus ulcers was the institution of local measures, in addition to the general cleansing measures just described, to eradicate gross infection and prepare the bed of the ulcer for skin grafting or for surgical incision and plastic restitution of the defect.

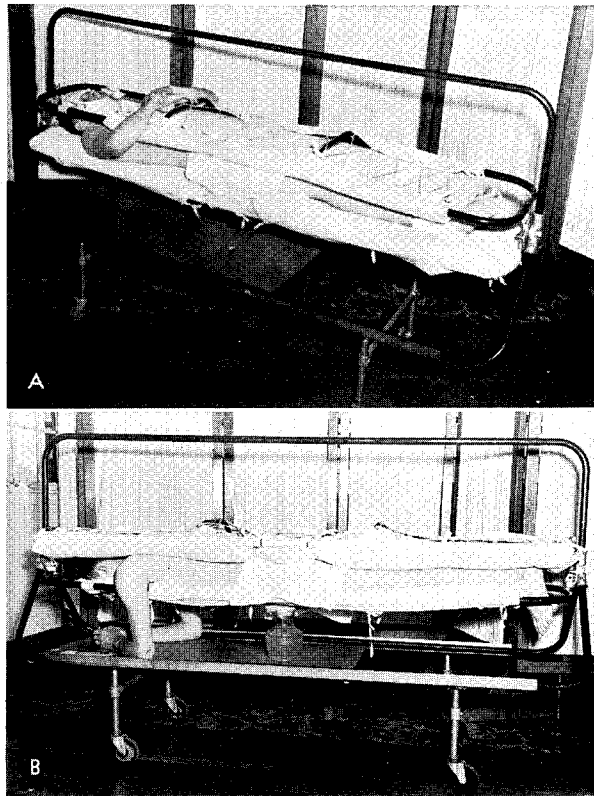

FIGURE 47.—Care of paraplegic on Stryker frame. A. Patient in supine position. B. Patient in prone position after being turned.

Debridement of all necrotic tissue was the first essential of management. It was repeated as necessary until no more sloughing tissue was present. Moist necrotic tissue was removed immediately, but mumified tissue was left in situ. No debridement was done until a line of cleavage was evident.

There was general agreement on the necessity for initial debridement, but thereafter there was no agreement at all on the local measures to be employed to hasten preparation for surgery. Some observers thought that pressure dressings, changed twice daily, were effective in lessening local anemia and tissue anoxia. Others believed that more effective results were achieved by controlled exposure of the ulcer to air and sunlight. Still others believed that, when feasible, it was well to elevate the affected part, to improve the blood supply. Fluorescein studies, however, with observations under light, paralleled the clinical impression that the blood supply to decubitus ulcers was generally good.

Although no effort was made to secure bacteriologic sterility, numerous local applications were used. Among the agents employed were sugar, min-

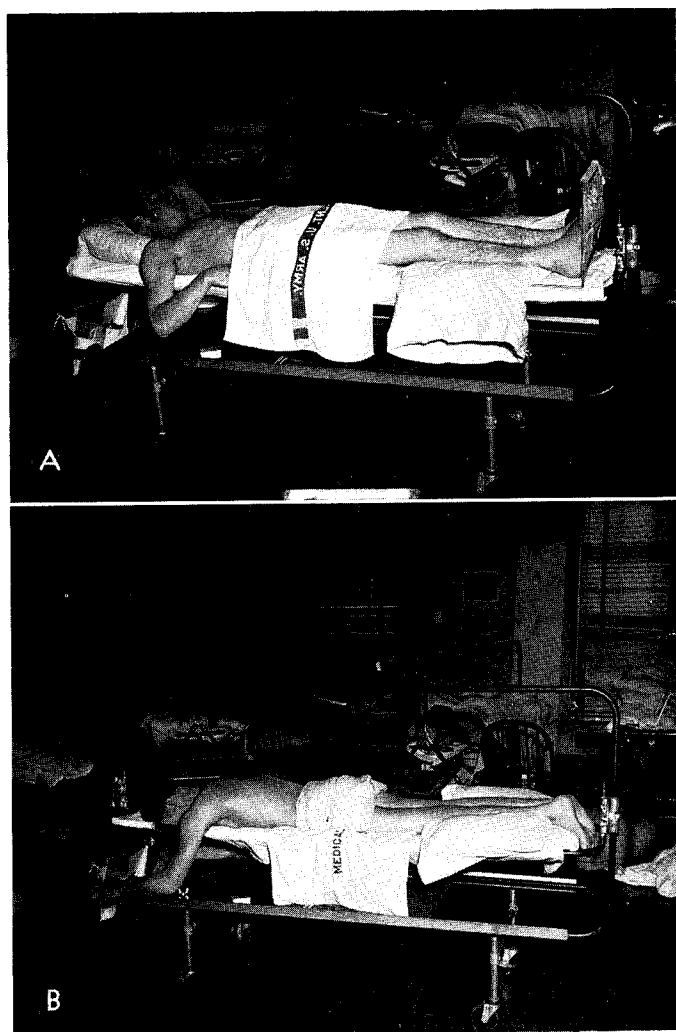

FIGURE 48.—Care of paraplegic on Stryker frame. A. Patient in supine position. B. Patient in prone position after being turned.

eral oil, balsam of Peru, horse serum, gentian violet, tannic acid, chloramine-T (Chlorazene), chloroazodin (Azochloramid), boric acid, acetic acid (which was always used when *Pseudomonas* infection was present), castor oil, iodoform, Dakin's solution, petrolatum-impregnated ointments, urea ointment, and various solutions and ointments containing penicillin. At Cushing General Hospital, Framingham, Mass., healthy granulations appeared rapidly after the use of a paste composed of concentrated red blood cells, thickened with agar and containing penicillin. Secondary closure was possible in 17 such cases, in all of which the bedsores were deep and penetrating; those over the trochanter measured up to 5 cm. and those over the sacrum

up to 7 cm. in diameter. On the other hand, the experience with red blood cell paste at DeWitt General Hospital was not such as to encourage its extensive use. The injection into the granulating surfaces of the ulcer of a ground-up solution prepared from autogenous skin does not seem to have been used at any of the paraplegic centers.

When Dakin's solution was used, normal adjacent skin frequently became irritated. The use of petrolatum-impregnated gauze or of tincture of benzoin afforded protection and was particularly useful beneath adhesive tape. At DeWitt General Hospital, adhesive strapping was found to be remarkably useful in some cases in reducing the size of ulcers; it was reported to support the tissues, relieve local edema and anoxia, and keep the edges mechanically approximated. Most observers, on the contrary, believed that adhesive tape should be used only to hold dressings in place and then with great caution, because the skin irritation produced by the necessarily frequent changes of dressing often led to ulceration.

At McCaw General Hospital, Walla Walla, Wash., the policy was to pack the cavity left after debridement of an ulcer with gauze saturated with zinc peroxide. Packing was so effected that all wound surfaces were in contact with the gauze, but it was sufficiently loose not to traumatize the area and cause further undermining. This treatment, because it afforded an oxygenated environment, was particularly efficacious when anaerobic organisms were present. Similarly good results were obtained with the use of Dakin's solution or chloramine-T. The proper use of either of these solutions resulted in digestion of necrotic tissue and stimulation of granulations. Penicillin-saturated gauze was sometimes effective, but results with chloroazodin were not good. If these methods proved inadequate, the undermined pockets were incised and packed open.

This list of agents and techniques scarcely covers all the methods used in the local management of decubitus ulcers. Their number and variety indicate the generally unsatisfactory results accomplished with all of them. In retrospect, it seems that the simpler methods, such as the use of penicillin ointment, probably gave the best results.

Surgical Measures

Under a combination of the methods described, ulcers of small to moderate size could be expected to heal eventually in most cases, but it was a slow process, extending over many months. Moreover, the thin-based scar which resulted could be expected to break down under the slightest trauma. When this happened, new ulcers were likely to form.

The employment of surgical measures in the management of decubitus ulcers was the result of evolution. There was little if any background of experience with this plan when the United States entered World War II. It was natural, therefore, that, following the observation that ulcers which healed spontaneously were notoriously unstable, the first surgical efforts

should be directed toward skin grafting. The method was used chiefly for sacral ulcers. Ulcers treated in this manner proved more stable than those which had healed spontaneously, but the thin, atrophic surface which resulted showed tendencies toward erosion (fig. 49). In the meantime, con-



FIGURE 49.—Sacral decubitus ulcer in paraplegic patient. A. Ulcer after preparation for graft. B. Ulcer after application of split-thickness skin graft.

siderable success was being obtained by direct closure of small ulcers in the sacral and trochanteric regions, and the success of these measures in small ulcers led to more daring attacks upon larger trochanteric and sacral ulcers.

Rationale.—It was estimated that the time saved in treating ulcers in this manner varied from 6 months in an ulcer an inch or less in diameter to 2 years or more in larger ulcers. Some sacral and trochanteric ulcers, it was thought, would have taken as long as 5 years to heal by nonsurgical methods; aggressive surgery in ulcers of this kind was lifesaving in some cases, and eventually it was believed that the excision and closure of ulcers as small as three-fourths of an inch in diameter which had penetrated to the subcutaneous tissue was good practice.

An additional reason for a prompt resort to surgery was that early ambulation, which was the desideratum in all these patients, was impossible until their decubitus ulcers were fully healed. Simply getting the patient out of bed often effected an almost miraculous improvement in his morale. Finally, nursing care was greatly decreased by closure of the ulcer by one method or another.

Preoperative preparation.—A paraplegic patient was regarded as ready for operative intervention (1) when he had been in positive nitrogen balance

for several weeks, as manifested clinically by an improvement in weight, strength, and general well being (p. 151), and (2) when the ulcer showed no evidence of acute inflammation; was free from sloughing fascia, muscle, and other necrotic tissue; and presented a fixed margin invaded by vigorously growing epithelium.

No surgery could be attempted until the decubitus ulcer appeared healthy. Soft, fluffy, weeping granulations could not be expected to function for the growth of epithelium. Even for simple closure, the apposing granulating surfaces had to be smooth, firm, and relatively dry. If they were not smooth, fluid pockets would form and would eventually dissect away the proposed line of apposition. If skin grafts were used, they would not adhere and would float off in the secretions from the wound.

Captain Barker, of Newton D. Baker General Hospital, who had a particularly wide experience with the surgery of decubitus ulcers, preferred to prepare his patients as follows: As soon as a definite line of demarcation became evident, the necrotic tissue was dissected away by scissors. Then, until the patient and his wound were both ready for surgery, the ulcers were dressed with boric acid, urea ointment, or an emulsion made by mixing 4 cc. of penicillin with 1 ounce of petrolatum. In his experience, the appearance of the ulcer did not vary greatly with the kind of ointment used. When the base was clean, the operation was done; there was no attempt at bacteriologic cleanliness.

Some surgeons used dressings saturated with physiologic salt solution for 48 hours before operation. Others used no special immediate local measures.

Since skin grafts do not take well in anemic subjects, blood studies were made before operation, and transfusions were given as necessary. Vitamin C was sometimes administered, on the ground that it plays a role in tissue healing.

Penicillin was in general use when paraplegic patients began to be received in large numbers in Zone of Interior hospitals, and it was frequently used before and after surgery on decubitus ulcers. At Cushing General Hospital, for instance, it was given systematically for 48 hours before operation and for 21 days afterward. At operation, the wound was filled with penicillin solution, and the solution was also injected through the suture line twice daily for 10 days after operation.

This plan was originally found very effective. As time passed, however, some centers reported that when it was used, a high incidence of extensive, destructive *Pseudomonas* infection occurred after skin grafting because other organisms were being killed off. The use of penicillin in paraplegics to be submitted to skin grafting was therefore discontinued at Dibble General Hospital, Menlo Park, Calif., DeWitt General Hospital, and other centers which had had the same experience.

Techniques.—The surgical techniques used in decubitus ulcers¹ varied from hospital to hospital (figs. 50, 51, and 52).

Primary excision and closure was the method of choice in small ulcers. The ulcer was completely excised, the excision including the scar tissue, peripheral rim, and granulating base. Debridement was continued until a firm, healthy base was reached unless the ulcer was so close to the bone that



FIGURE 50.—Plastic repair of decubitus ulcers. A. Simple trochanteric ulcer involving skin and subcutaneous tissues. B. Closure of ulcer by undermining of skin flaps.

no excision of granulation tissue was possible. The tissues about the ulcer were then extensively undermined, usually for several inches, until closure could be effected without tension. Closure was effected in layers, with one

¹ (1) Croce, E. J., Schullinger, R. N., and Shearer, T. P.: The Operative Treatment of Decubitus Ulcer. *Ann. Surg.* 123: 53-69, January 1946. (2) Barker, D. E., Elkins, C. W., and Poer, D. H.: Methods of Closure of Decubitus Ulcers in the Paralyzed Patient. *Ann. Surg.* 123: 523-533, April 1946. (3) Gibbon, J. H., Jr., and Freeman, L. W.: The Primary Closure of Decubitus Ulcers. *Ann. Surg.* 124: 1148-1164, December 1946. (4) White, J. C., and Hamm, W. G.: Primary Closure of Bedsores by Plastic Surgery. *Ann. Surg.* 124: 1136-1147, December 1946. (5) Barker, D. E.: Late Results in Surgery for Decubitus Ulcers. *Am. J. Surg.* 74: 180-182, August 1947. (6) Conway, H., Kraissl, C. J., Clifford, R. H., III, Gelb, J., Joseph, J. M., and Leveridge, L. L.: The Plastic Surgical Closure of Decubitus Ulcers in Patients With Paraplegia. *Surg. Gynec. & Obst.* 85: 321-332, September 1947.



FIGURE 51.—Plastic repair of decubitus ulcers. A. Trochanteric ulcer involving skin, subcutaneous tissues, and fascia. B. Repair of ulcer by undermining of skin flaps and advance of gluteal skin.

suture line for the deep fascia and one for the skin, except in the trochanteric area, where three layers of sutures were usually required, as the ulcer frequently extended through the fascia lata and the fascia of the gluteus maximus. An extremely careful technique was necessary to secure satisfactory healing. Nonabsorbable sutures, preferably of tantalum or steel wire, were used and were left in place for 21 days.

This technique gave excellent results, and at some centers virtually superseded all other methods of closure. At Cushing General Hospital, for instance, of 52 operations analyzed over one period, 60 percent of the ulcers closed by suture remained healed after the first attempt, though some of the sacral ulcers were as large as 15 cm. in diameter. A number of these cases had previously been managed by grafts of various kinds.

When simple closure with undermining of the adjacent skin was not possible, full-thickness flaps of skin and subcutaneous tissues from adjacent surfaces could be rotated to fill the defect. This method was particularly successful in sacral ulcers and ulcers over the trochanteric region (in which skin grafting was not desirable), because atrophy of the gluteus muscle, as the result of malnutrition, had usually left an abundance of loose skin which could be borrowed from the buttocks (fig. 53). If a large enough flap could not be secured, split-thickness skin grafts could be used to supplement it. In Captain Barker's experience, about 80 percent of ulcers managed by primary closure with rotation flaps healed satisfactorily after the first operation. The technique he employed was very precise; the flap was in the exact pattern of the ulcer and was usually transferred to it from an area ventral to it. In the technique employed by Maj. William B. Scoville, MC, the posterior surface of the trunk was extensively undermined after the ulcer

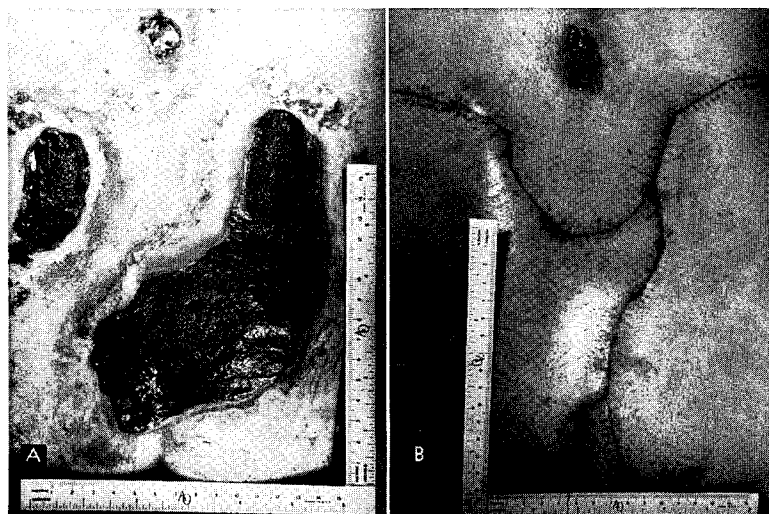

FIGURE 52.—Plastic repair of decubitus ulcers. A. Multiple sacral decubitus ulcers. B. Repair of ulcers by undermining and advance of skin flaps.

was debrided, and an area of skin and subcutaneous tissue large enough to cover the defect was shifted caudally.

In any comment on the results of skin grafting in decubitus ulcers, it must be remembered that this technique was generally used in the more unfavorable cases, in which the ulcers, practically always over the sacrum, were very large and in which the patients were likely to be poor surgical risks and unfit for extensive radical surgery.

Pinch grafts were not found very desirable, and split-thickness skin grafts, twelve one-thousandths of an inch in thickness, were most often used. The granulating area was shaved down to a firm, healthy base except when the ulcer lay so close to the bone that this was not possible. The graft was obtained from the patient, usually from the back. The donor area practically always healed without difficulty, as did the surgical incision, even though it was made in an anesthetic area.

At Halloran General Hospital, Capt. (later Maj.) Edmund J. Croce, MC, described a method for the plastic closure of large sacral ulcers based on the consideration that the skin from the iliac crest above to the trochanter laterally is normally free and loose, and that this normal state is accentuated by the loss of subcutaneous fat and the atrophy of the glutei common in paraplegics.

After the ulcer was excised, curvilinear incisions were made on each side of the ulcer, extending along the iliac crests above and into the buttocks below. The large flaps thus outlined were raised from the gluteal fascia. When they were rotated toward the middle of the ulcer and approximated, the defect could be completely closed with a layer of skin and normal sub-

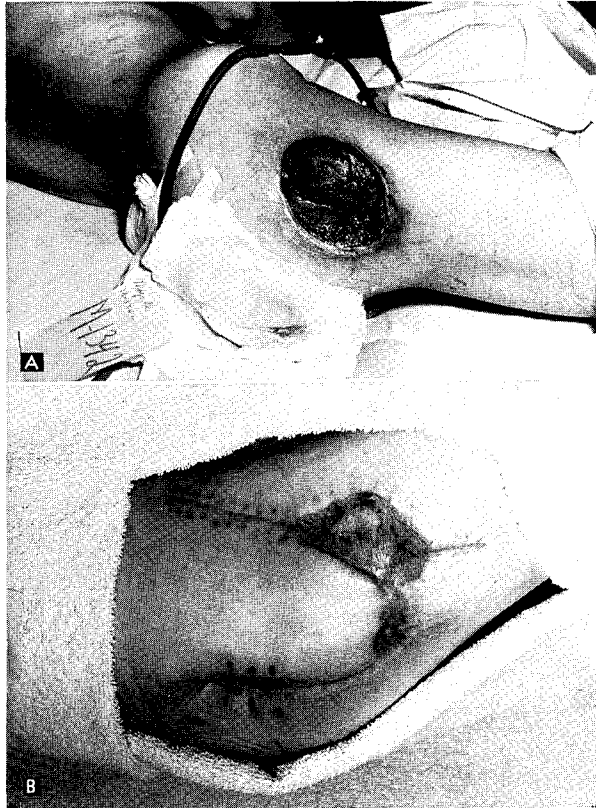

FIGURE 53.—Plastic repair of decubitus ulcers. A. Deep trochanteric ulcer extending to femur. B. Repair of ulcer by rotation full-thickness skin flap technique, supplemented by small split-thickness skin graft.

cutaneous tissue apparently capable of withstanding the abuse which the skin in this area ordinarily receives. A fine silk technique (000000 black silk) was used throughout. Originally, some of the larger ulcers were closed in two stages. Later, ulcers from 10 to 12 cm. long and from 12 to 15 cm. wide were closed in a single stage. The end results of these techniques were apparently more durable than the use of split-thickness skin grafts applied directly over the sacrum, some of which had broken down repeatedly in patients in whom the Croce method proved entirely satisfactory (fig. 54).

In a few centers, the following technique of skin grafting was used: Five cubic centimeters of whole blood, taken from the patient, was centrifuged, and the serum was painted on the recipient site of the graft. The white-cell layer was then taken off with a loop and mixed with Tyrode's grafts. Narrow strips were used, no attempt being made to cover the entire area with a single graft. The wound was covered with a strip of gauze, applied with

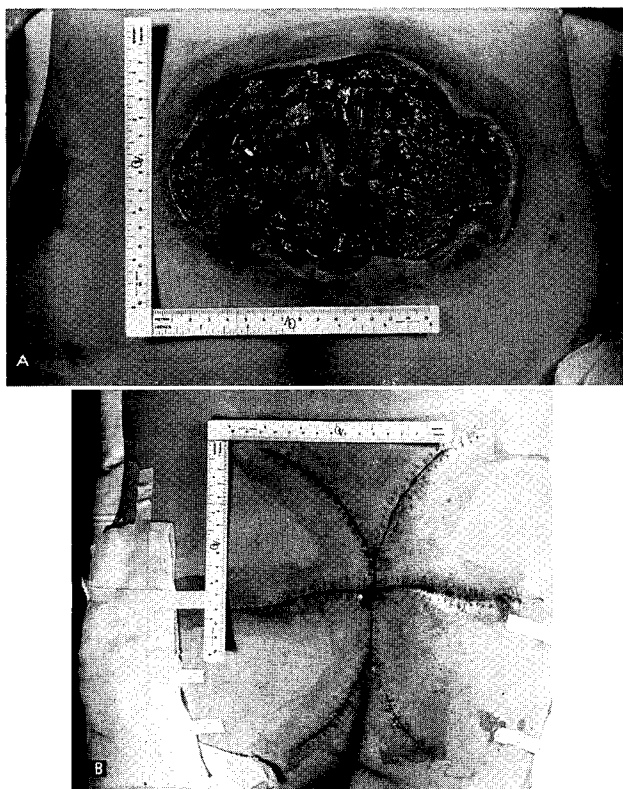

FIGURE 54.—Plastic repair of decubitus ulcers. A. Extensive decubitus ulcer of sacrum. B. Repair of ulcer by multiple full-thickness flap technique.

slight pressure, to prevent bubble formation. Results with this technique were apparently no better than those achieved by standard, less complicated methods.

Postoperative care.—Postoperative care consisted of the standard routine, usually supplemented by wet dressings for 3 or 4 days if grafts had been employed. At Halloran General Hospital, postoperative dressings were placed in charge of a single nurse. The medical officers had no time to undertake them, and an interested nurse handled them very capably.

A major postoperative problem was to hold the dressings, and therefore the grafts, in place in patients whose paraplegic state required that they be moved constantly. No matter how careful ward personnel were, dressings lost position, and the grafts were sometimes lost also. Captain Barker reported a case in which three unsuccessful operations were open to this explanation. The patient had five large ulcers, from which there was a daily protein loss of 50 gm., with a reversal of the albumin-globulin ratio.

NUTRITION AND DIET

Malnutrition and Protein Deficits

A chain of circumstances was responsible for the poor state of nutrition which was common to most paraplegics with battle-incurred wounds and which was far more severe than is the malnutrition likely to be encountered in the great majority of paraplegics treated in civilian practice. When these patients were received in Zone of Interior hospitals, weight losses were sometimes enormous. In one series of 82 patients reported by Col. Robert H. Kennedy, MC, from Percy Jones General Hospital, the average weight loss was 50 pounds.

Complicating conditions.—In addition to the complications which arose more or less directly from the spinal cord injury, such as urinary tract infection and decubitus ulcers, concomitant injuries were frequently present in these paraplegic patients and assumed more than ordinary significance because they added to the already grave burdens which they were carrying. At one time, 32 paraplegics in the paraplegic center at Ashford General Hospital, White Sulphur Springs, W. Va., also presented injuries of the peripheral nerves and blood vessels; compound fractures; traumatic amputations; penetrating wounds of the chest; and penetrating wounds of the abdomen, some of which had required colostomy. Three of these patients presented the bizarre complications of cecal, urinary and biliary fistulas, respectively, through the spinal wound. Another had an osteomyelitis of the spine with a psoas abscess, and still another had chronic intermittent meningitis, probably arising from a number of retained foreign bodies. Some of these complicating wounds were themselves complicated by such conditions as arteriovenous and arterial aneurysms and empyema.

Urinary tract infection was almost universal and almost invariably produced a low-grade febrile response, sometimes interrupted by acute episodes, lasting a week or more, of chills, sweats, and high fever. Pyelonephritis was the most usual cause of these episodes, though, in an occasional case, a patchy pneumonitis or a malarial attack might be responsible. The frequent blood cultures taken in all febrile cases were practically always negative.

The physical consequences of these wounds and the mental depression associated with them frequently culminated in anorexia. This state, combined with the infections and draining wounds present, caused serious protein deficits, which were difficult to overcome because of the problem of getting enough food into the patients, particularly the proteins which they needed. Here, psychologic considerations also played a part. It was repeatedly found that these men would begin to eat only when they could be convinced that the future still held something for them.

Active management of the paraplegic state was necessarily deferred until complicating conditions were cleared up. Intensive treatment was

necessary. Infected and draining wounds had to be treated and closed. Abdominal wounds with perforation of hollow viscera might require more than one operation on the gastrointestinal tract. Enteric fistulas were sometimes almost intractable.

Disorders of calcium metabolism.—Disorders of calcium metabolism were rather frequent in paraplegic patients.² Capt. (later Lt. Col.) A. Bradley Soule, Jr., MC, reported a number of such cases. At one of the paraplegic conferences, he also described soft-tissue calcification about the hips and in the lower extremities demonstrable by roentgenograms in 23 of a series of 62 patients with spinal cord lesions (fig. 55). It seemed a reasonable assumption that the changes were the result of stasis of blood flow in patients with elevated blood calcium levels and that they were fostered by recumbency. Other observers commented on the extensive osteoporosis often observed in the bones of the lower extremities in patients who led a wheel-chair existence. Pathologic fractures might follow even minor trauma.

A remarkable improvement occurred in these patients when they became ambulatory. Longitudinal pressure upon the long bones of the extremities apparently stimulated calcification and greatly reduced the possibilities of both osteoporosis and of calculus formation in the urinary tract (p. 104).

Protein Deficits

The most serious of the nutritional deficiencies exhibited by paraplegic patients concerned protein. Protein losses occurred from the so-called toxic destruction which is a concomitant of all serious disease or injury, from the ordinary wear and tear of daily living, and from decubitus ulcers, the importance of which as a cause of protein deficits was recognized for the first time in World War II.

Decubitus ulcers.—At almost every hospital in which paraplegics were treated, a conspicuous and definite relation was established between the plasma protein levels and the status of decubitus ulcers as well as their actual development. In the presence of a protein deficiency, the tissues were so changed in character that it apparently required a smaller amount of pressure, or the same amount of pressure for a shorter period, to cause necrosis. When malnutrition reached a certain point, even the amount of pressure exerted by the recumbent body of ordinary periods of rest might cause bedsores.

Studies by Mulholland and his associates³ at the New York University

² (1) Herrmann, L. G., Reineke, H. G., and Caldwell, J. A.: Post-traumatic Painful Osteoporosis: A Clinical and Roentgenological Entity. *Am. J. Roentgenol.* 47: 353-361, March 1942. (2) Soule, A. B., Jr.: Neurogenic Ossifying Fibromyopathies: A Preliminary Report. *J. Neurosurg.* 2: 485-497, November 1945. (3) Soule, A. B., Jr., and Stiff, D. W. S.: Changes in the Bones and Soft Tissues in Paraplegia. *Bull. U.S. Army M. Dept.* 9: 1018-1021, December 1949.

³ Mulholland, J. H., Tui, C., Wright, A. M., Vinci, V., and Shafroff, B.: Protein Metabolism and Bed Sores. *Ann. Surg.* 118: 1015-1023, December 1943.

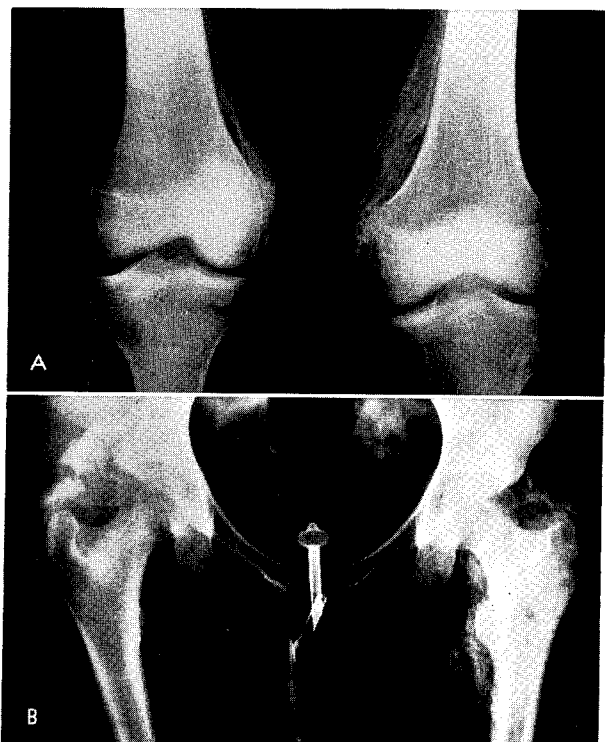

FIGURE 55.—Roentgenograms showing neurogenic ossifying fibromyopathies in patients with traumatic paraplegia. A. Extensive ossifications about knees 116 days after spinal injuries. B. Extensive and progressive ossifications about both hip joints, with virtual ankylosis, 6 months after onset of paraplegia.

College of Medicine, established a number of useful and significant points, as follows:

1. If patients had had large doses of hypnotics, which kept them lying in one position for a long time, bedsores developed rapidly.
2. The same mechanism was set up by the use of casts in patients with fractures.
3. When there was loss of nitrogen from the body, from toxic causes, from undernutrition, or from a combination of these causes, the character of the tissues was altered. In normal patients, who were able to change their position frequently, bedsores did not develop at all. They developed rapidly in malnourished patients.

4. In random studies of patients with bedsores, it was invariably found that the plasma-protein concentration was below the lower limits of normal.

Studies of decubitus ulcers in the paraplegic centers practically always showed large losses of protein. Various methods were used to demonstrate this fact. 1st Lt. (later Capt.) Mark A. Jacobs, SnC, covered ulcers with

pads of cellucotton for 24 hours and then carried out micro-Kjeldahl determinations on the exudate recovered from the dressings. All the patients whom he studied had some loss of protein from the ulcers, and 1 patient, with 5 ulcers, had a total protein loss by this route of over 40 gm. in 24 hours. At other centers, losses up to 50 gm. in 24 hours were reported in some cases.

Proof of the importance of protein loss from ulcers was furnished not only by laboratory evidence but also by the improvement which resulted when the ulcers were closed or skin grafts were applied. Once a good nutritional balance had been attained, progressive, spontaneous healing of small ulcers was frequently observed.

Evaluation of protein deficits.—The most severely malnourished paraplegics practically always revealed an increase in interstitial tissue fluid. This increase was demonstrated by Maj. Helmuth Sprinz, MC, working at Halloran General Hospital, to be characteristic of severe protein depletion. In these cases, the plasma volume of the blood was normal or even slightly higher than normal, but there was a decrease in the volume of circulating red blood cells. The serum protein concentration and the albumin-globulin ratio were not significantly altered except in patients with nutritional edema, in whom a lowering of the serum-protein concentration and a reversal of the albumin-globulin ratio were likely to be observed.

When this reversal had occurred, it had to be considered indicative of an extensive depletion of protein stores, in view of the established fact that each gram loss of plasma protein was accompanied by a loss of about 30 gm. of tissue protein. In order to use a determination of the total plasma protein as an index of the state of protein malnutrition, two important factors had to be taken into consideration. The first was the effect of dehydration. The second was the presence of decreased levels of albumin and increased levels of globulin. As plasma protein diminished, the water-retaining power of the blood was also decreased. Fluid was lost into tissue spaces, and there was an increased concentration of plasma, with a consequent decrease in total plasma volume. When this occurred, the quantity of protein which would have been low when the plasma volume was normal might appear normal or even higher than normal. Unless these considerations were borne in mind, the plasma protein value would be likely to be regarded as normal when actually protein depletion was present. To obviate these pitfalls, red blood cell counts and hematocrit determinations were necessary, as well as determinations of the plasma protein and of the albumin-globulin ratio.

Dietary Correction

The diet of paraplegics was always a subject of intensive discussion at paraplegic conferences. Obvious points were stressed, such as the placing of one dietitian in charge of paraplegics; the importance of serving the food

appetizingly; and observation of the amount of food which was not consumed. Curiously, there was a professional tendency to disregard the food which was not eaten, though all the dietary planning in the world was perfectly useless if patients did not eat what was put before them.

It was a good plan to get the patients out of bed and send them to their meals in wheelchairs as soon as possible. As their morale improved, so did their appetites, though patients with colostomies and those with malaria presented special problems which were not so readily solved.

The basic hospital diet in U.S. Army hospitals provided the patients with about 2,800 calories daily. The protein content of this diet ranged from 100 to 113 gm. per day. This provision, which amounted to about 1.5 gm. per kilo of body weight daily, was in excess of the National Research Council estimate that the daily requirement was 1 gm. per kilo. In paraplegic patients, the total caloric value of the diet was stepped up to about 3,200 calories in most hospitals and the protein intake to 150 to 175 gm. daily. In the face of special necessities, up to 300 gm. per day could be administered by supplemental feedings.

The components of the diet were so planned as to supply as much energy as possible, with the idea of sparing the protein to a maximum degree for use in anabolic reactions. The fat content was moderate. A certain amount was necessary, to aid in the absorption of fat-soluble vitamins, though some observers thought that fats should be strictly limited because they lengthen the emptying time of the stomach and so retard digestion.

Vitamin supplements were used on indications, in some instances probably more liberally than was necessary. The approximate vitamin A content of the average hospital diet was 14,000 units daily, against an estimated requirement of 5,000 units daily. It was doubtful that patients whose utilization of vitamin A was normal and who had no hepatic disease and no disorders preventing bile from entering into the intestinal tract required any more. The thiamine, riboflavin, and niacin contents of the diet were also far above normal. The average vitamin C content of the diet was 165 mg. daily, against a requirement of 75 mg.

The situation was somewhat different when mineral oil, which was the laxative of choice in paraplegics, had to be administered, since it is known to interfere with the absorption of the fat-soluble vitamins D and K. In these cases, supplemental vitamin therapy was used, with the full recognition that Peter was being robbed to pay Paul.

Adjunct measures.—When the patient was anemic, the deficiency had to be corrected before satisfactory tissue and plasma protein regeneration could occur; otherwise, most of the protein administered would be diverted to the synthesis of hemoglobin. Whole blood was therefore used as liberally as necessary to correct acute plasma protein deficiencies, especially when edema of the tissues was obvious.

The use of plasma in chronic hypoalbuminemia due to malnutrition,

while logical, was entirely impractical. As already pointed out, for every gram of plasma protein which remained in the blood, as much as 30 gm. might be removed by the tissues. To supply 2,000 gm. of protein for the entire body would require, it was estimated, 30 liters of plasma, which would require 120 donors.

From the nutritional point of view, therefore, protein in excess amounts had to be administered from other sources, chiefly from the protein concentrates or hydrolysates which were available commercially. These preparations were available for both oral and intravenous administration. A hydrolysate of casein, the protein component of milk, was then available for intravenous administration. A preparation of wheat, beef, and yeast proteins, as well as of casein, was available for oral use.

When it was possible, it was always desirable to confine alimentation to the oral route. This was partly because this is the physiologic method of taking food and partly because of the risk, in intravenous alimentation, of overloading the circulation of patients whose plasma protein levels were dangerously low. To administer 100 gm. of protein, for instance, in the form of a 5-percent Amigen solution required the introduction of 2 liters of fluid. Such amounts could not be tolerated over a very long period.

The chief drawback to the oral administration of Amigen was that it was extremely unpalatable, and ingenious ways had to be found to disguise the taste. Another preparation, Aminoids, though it had less than half the protein content of Amigen, was more generally useful because it was more palatable. These hydrolysates, incorporated in food and put into fruit juices and milk shakes, increased the protein intake by 50 to 100 gm. of protein daily.

Results.—Evidence that protein deficits had been corrected was usually prompt and convincing. It became progressively easier to restore and maintain a normal nitrogen balance. The efficacy of all therapeutic agents was enhanced. Chronic infection was more readily controlled. Wound healing was faster and more satisfactory. Finally, as already noted, decubitus ulcers healed more rapidly, and skin-grafting procedures were more successful.⁴

BLADDER FUNCTION

The paraplegic patient is the captive of the dead half of his body. Bladder and bowel function and skin care are therefore extremely important for his mere existence.

⁴ In July 1945, a research project on metabolic studies on patients with spinal cord injuries was warmly approved in the Surgical Consultants Division, Office of the Surgeon General, and was also approved by the Commanding General, Army Service Forces. It was to be conducted under the direction of the surgical consultant, Fifth Service Command, and the chief of surgery, Wakeman General Hospital, Camp Atterbury, Ind. This project, which was to be continued during the war with Japan and which was to have urgent priority, did not come into existence because the war with Japan ended about a month after it had been approved.

The urologic aspects of spinal cord injuries are discussed in detail in a separate chapter of this volume (p. 67), and no additional discussion of them is required in this chapter.

The management of bladder function and the prevention of urinary tract complications was a constant struggle in Zone of Interior paraplegic centers. Typical tidal drainage setups are shown in figures 56, 57, and 58.

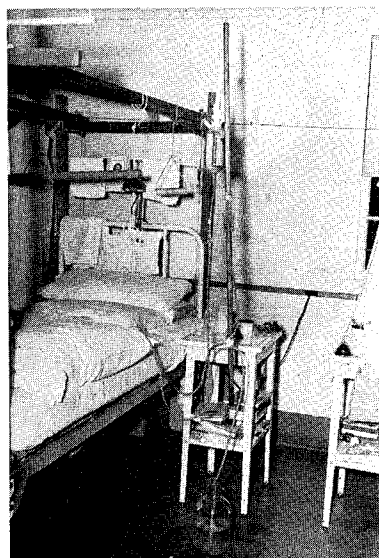

FIGURE 56.—Bedside installation for tidal-drainage apparatus in paraplegia colony.

Calculi were a continuing problem,⁵ sometimes being observed after only a month of recumbency. Treatment was basically acidification of the urine, which required repeated, frequent determinations of the urinary pH. Repeated roentgenologic studies (films of the kidneys, ureters, and bladder, and intravenous urograms) and inspections of the bladder were necessary, because paralyzed patients do not experience pain and tenderness from calculi as do normal patients. Similarly, diagnosis was likely to be delayed even in such conditions as epididymitis and torsion of the spermatic cord.

The various paraplegic centers developed their own special technical methods, such as the use of the suprapubic opening for inspection of the bladder and removal of stones and encrustations of the mucosa; the reaction by this method was less than after cystoscopy by the transurethral route. Rolling the patient on his abdomen during irrigation was also found to facilitate drainage by causing the gravitation of the exudate toward the

⁵ The importance of urinary calculi in paraplegic patients did not diminish with the passage of time. In 1948, it was reported, in Veterans' Administration Technical Bulletin 10-503, pp. 15-27, 15 Dec. 1948, that they were present in 42.5 percent of the 458 paraplegics treated at the Veterans' Administration hospital at Van Nuys, Calif. About a third of the stones were vesical.

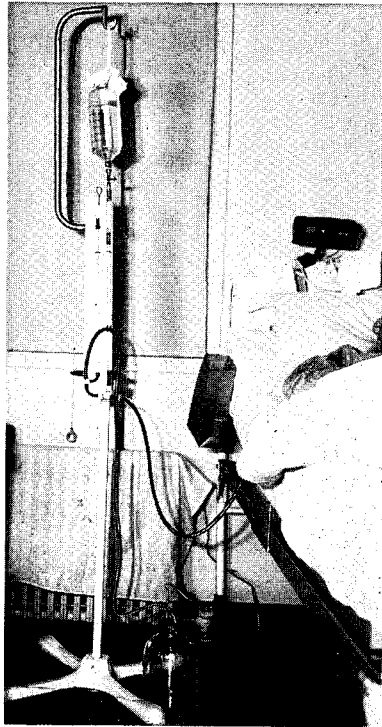

FIGURE 57.—Detail of manometer in typical tidal-drainage apparatus.

suprapubic catheter. When irrigation was carried out in the supine position, it was often found that only the supernatant exudate had been removed.

Results of using stone-dissolving solutions were not encouraging, and the best conservative method of treatment was found to be getting the patient out of bed. Surgical procedures were always delayed until it was clear that his condition would be jeopardized without them.

A special chart for recording urinary tract management and progress was useful (fig. 59).

BOWEL FUNCTION

Bowel function was always a problem in paraplegics. The basis of management was a complete knowledge of the individual patient's status and needs, which implied careful recordkeeping. A daily ward chart (fig. 60) was useful for this purpose. From it, the ward officer could determine at once, for all his patients, the type of cathartic necessary, the amount to be administered, and the necessary frequency of medication. The objective was to reduce the use of cathartics and the necessity for enemas to the minimum possible in each case. Frequent digital examinations were necessary to rule out rectal impaction.

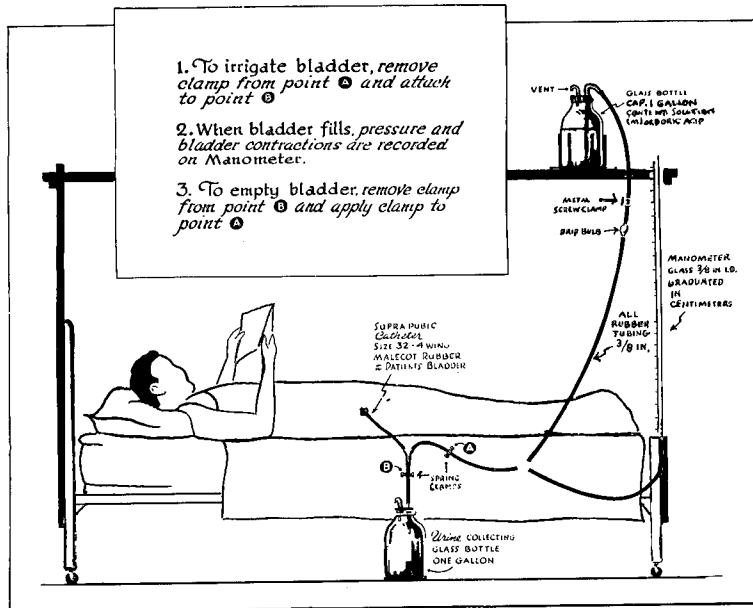

A

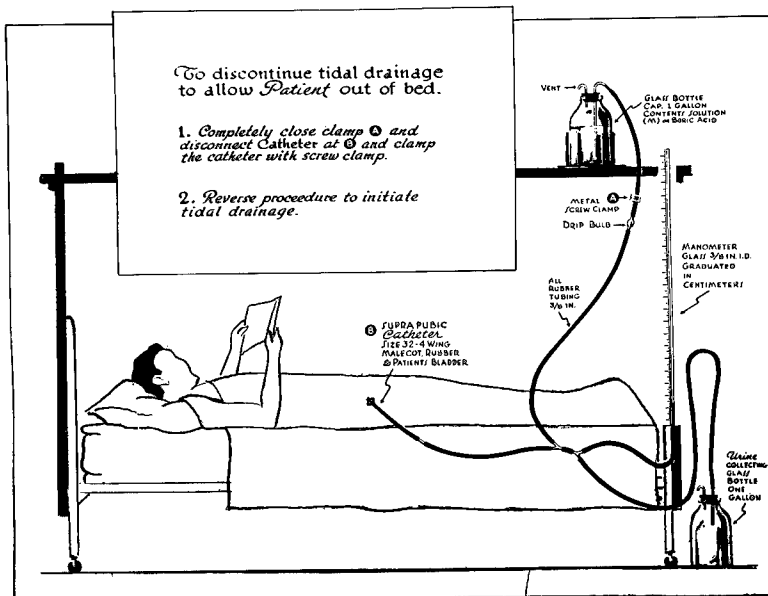

B

FIGURE 58.—Graphic chart and instruction sheet used to instruct ward personnel in management of tidal-drainage apparatus. A. Bladder irrigation. B. Discontinuance of bladder irrigation.

SPECIAL PROGRESS NOTES							
Name _____		Rank _____		Ward _____			
DATE	REACTION	CULTURE	CYSTOMETRIC	CYSTOSCOPIC	I.V.P.	ALBUMIN	MICROSCOPIC

FIGURE 59.—Ward chart depicting progress in genitourinary problems in paraplegic patients.

Even before the patient was able to assume an upright position in bed, bowel function could be improved by a number of mechanical measures. There was considerable improvement, for instance, when Fowler's position began to be used routinely, and, in some particularly favorable cases, spontaneous bowel movements occurred.

Experienced attendants often found the lateral recumbent position, with the legs flexed, satisfactory for cleansing of the bowel manually or by enema.

Before limited ambulation was possible in the regimen of a paraplegic patient, bowel management differed in only one detail from bowel management in any recumbent patient; every paraplegic needed constant observation and supervision when he was placed on a bedpan or over the aperture of a toilet guerney or Stryker frame, in order to prevent further skin necrosis or increased trauma to decubitus ulcers.

When the patient had progressed sufficiently, he was placed on a padded toilet guerney or toilet seat, to which he was lifted by a tackle (figs. 61, 62, 63, 64, and 65). The advanced degree of Fowler's position that could be attained on the toilet guerney allowed the patient full exercise of such

RESULTS OF ENEMAS GIVEN EVERY OTHER DAY.	ROUTINE: Mineral Oil 1 oz. daily; ½ oz. Petrolagar night before enema.																					
	STUBBORN CASES: Mineral Oil 2 oz. daily; 1 oz. Petrolar or 1 cc Pill night before enema.																					
	DATE	DATE	DATE	DATE	DATE	DATE	DATE	DATE	DATE	DATE	DATE	DATE										
H - HARD M - MEDIUM S - SOFT	H	M	S	H	M	S	H	M	S	H	M	S	H	M	S	H	M	S	H	M	S	
PATIENT'S NAME:																						

FIGURE 60.—Ward defecation record used in colony paraplegic care.

ancillary aids as pressure on the abdominal wall. When he was on the toilet, his bed could be given the necessary attention with far less expenditure of effort than when he was in it.

Each patient was instructed in the importance of active defecation and the prevention of overdilatation of the bowel, which could further destroy the functional response of the muscle fibers and the intrinsic nerves. He was taught how to replace impaired abdominal pressure by proper movements of the diaphragm and by manual support of the abdominal wall. He was shown how to apply his hands flat against the abdomen, take deep breaths, close the glottis, and then fix the diaphragm firmly. Instruction in certain musical instruments proved of value in improving bowel function.

All patients received an ounce of mineral oil every day, never with their meals. The night before an enema was ordered, the patient was given from ½ to 1 oz. of cascara petrolagar, or, in stubborn cases, a compound cathartic pill.

Enemas were necessarily administered by ward attendants, but these attendants were carefully instructed in the precautions necessary to avoid damaging the bowel. The bowel in paraplegia is also involved in the disturbance of sensory function below the level of the lesion, and an exceptional degree of care was necessary to prevent serious damage, including perforation, which might occur without any immediate reaction on the part of the patient. Attendants who performed catheterization required the same warn-

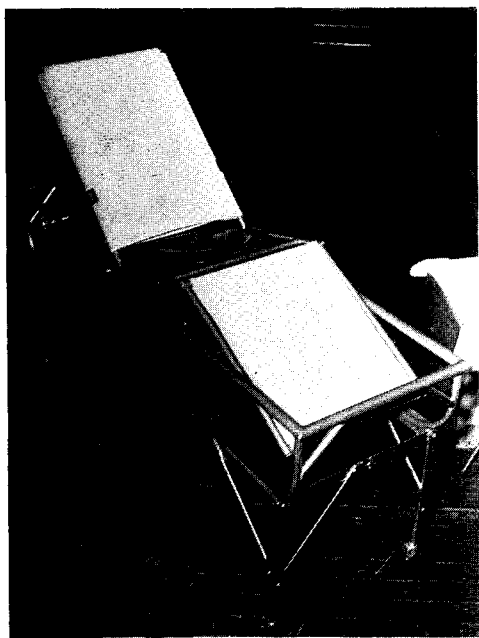

FIGURE 61.—Detail of lightweight toilet guerney, adjustable for Fowler's position or upright position, and readily cleansed.

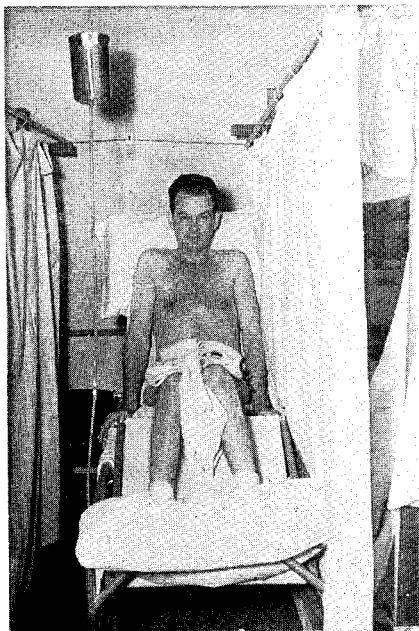

FIGURE 62.—Maximal physiologic position attained in adjustable toilet guerney for bowel evacuation. Note privacy obtainable for this purpose in any typical paraplegia colony. Note also self-administering enema apparatus.

ing. In the report of the enema, a special note was made of the consistency of the feces.

When paraplegic patients became fully conditioned in terms of shoulder-arm strength, had gained wheelchair ambulation, and were well versed in the care of bowel function, toilet arrangements became much less complicated. Two efficient installations are presented in figures 64 and 65, showing how transfer from wheelchair to toilet seat could be facilitated by the use of horizontal and vertical bars.

PERSONAL HYGIENE

Certain adaptations of facilities and equipment having to do with the personal hygiene of the paraplegic patient, though apparently minor, were most important. In these patients, the functions of washing and shaving must be performed sitting, in the wheelchair subserving ambulation. Basins and mirrors had to be lowered appropriately, and the undersurface of the washbasin had to be open, to provide for entrance of the legs and the forward part of the chair (fig. 66).

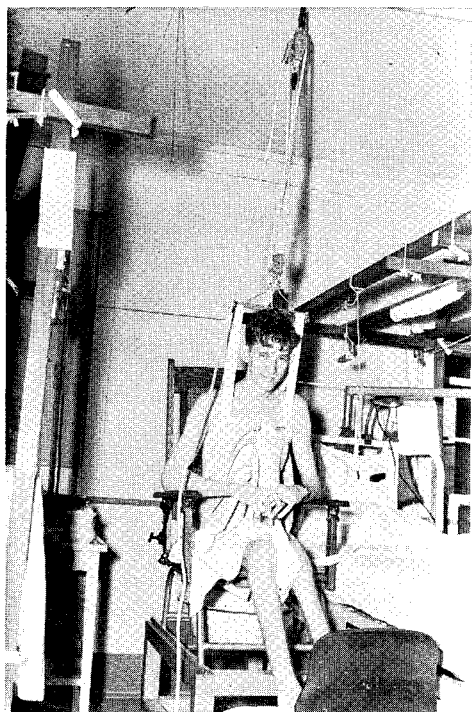

FIGURE 63.—Full sitting position on toilet seat achieved by shoulder-arm efforts of patient and overhead tackle. Strengthening of the muscles of the shoulder and arm was an important aspect of reconditioning and had already started by use of the bed bar and conditioning apparatus seen on patient's bed.



FIGURE 64.—Transfer from wheelchair to toilet seat carried out by fully conditioned paraplegic by means of lateral horizontal bars.

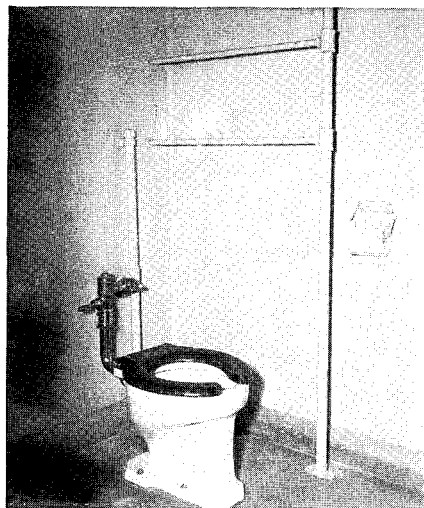

FIGURE 65.—Another toilet-seat design, utilizing vertical and horizontal bars, for transfer of paraplegic from wheelchair to toilet seat.

Bathing by the advanced paraplegic patient was easily mastered by the technique of transfer from the wheelchair after adequate shoulder-arm conditioning. Overhead bars, as already mentioned for the toilet, were mandatory. The overhead multiple bar was fixed to the wall and lowered to the desired diagonal position above the tub (fig. 67).

PSYCHIATRIC AND EMOTIONAL CONSIDERATIONS

It was impossible to treat paraplegics simply as medical and physical problems, without taking into consideration what had happened to them.

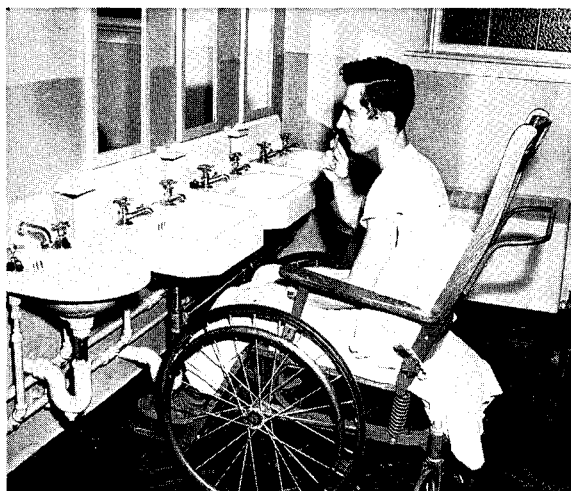

FIGURE 66.—Washbasin arrangement for wheelchair-ambulant paraplegic patient. Note low positions of washbasin and mirror and free entrance of forward part of wheelchair under basin.

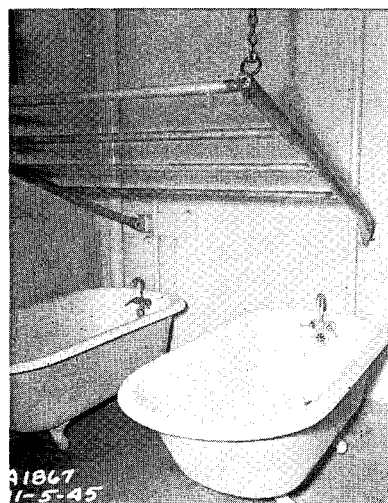

FIGURE 67.—Double tubs and overhead adjustable horizontal bars for use by wheelchair-ambulant paraplegic patients.

The spinal cord injury had usually occurred suddenly. Within a matter of moments, the status of the individual had changed from complete independence to almost complete dependence on others for transportation, nutrition, and bodily function. The adult, in effect, had abruptly returned to what amounted to the infantile state. The paralyzed soldier was more gravely affected physically than soldiers with deformities, amputations, and even loss of sight and hearing. He did not have to have a great deal of

intelligence and imagination to perceive what had happened to him in the spheres of society, work, and sex.

Paraplegic Survey

Interesting data on the soldier's emotional state were secured in the paraplegic survey conducted in December 1945 (p. 14). It was not clear, the report stated, to what extent the reporting medical officers had adjusted their concepts of normality to reflect the extreme disability from which these patients suffered, but they classified only 15 percent as depressed, while 5 percent were euphoric, 12 percent indifferent, and 68 percent normal.

No significant correlation was found between the emotional status of the patient and the level of his schooling, but the euphoric group contained no individual who had had less than 5 years of formal schooling. There was also no significant correlation between the emotional status and the AGCT score. The indifferent group was composed chiefly of men with low test scores who, in general, shared many of the characteristics of the depressed group.

There was a high percentage of farmers and a low percentage of salesmen, students, and professional men in the depressed group. The normal group contained a large percentage of salesmen, professional men, and students.

There was a positive—perhaps understandable—correlation between the emotional status of the patient and the ability of his family to care for him after his discharge. The normal group contained a high percentage of patients who could be cared for by their families, and the depressed group contained the largest percentage of patients whose families could not care for them. There was no significant correlation between the emotional groups and the frequency of family visits; the 15 percent of patients who had had no family visits at all manifested no special emotional reactions. There was a large percentage of both euphoric and depressed patients in the group of patients who received four visits or more a month. In the depressed group, the significant relationship was probably the large proportion of completely paralyzed patients, though patients with complete paralysis were on the whole no more depressed than those with incomplete paralysis.

The euphoric group was composed almost entirely of nonambulatory patients, and a higher than average number of ambulatory patients appeared in the depressed group.

Evolution of Policies of Management

Despondency and depression were the first inevitable consequences of the paraplegic state. Some of the men were convinced that their span of life would be measured in months. Others believed, or persuaded themselves that they believed, that their paralytic state was transient and that in a

matter of time they would be completely normal again. Both groups, before a great deal could be accomplished with them, had to be brought to terms with the realities of the situation. This meant facing the fact that the disability was permanent and that life must be lived with it.

Before any somatic rehabilitation could be attempted, the patient's self-confidence had to be revived, and he had to be given hope for the future. The medical officer explained to him in detail the specific aims of the rehabilitation program in its first phase; namely, to restore bowel and bladder control, to get him out of bed, and to teach him to walk again. Along with these physical objectives would go training for the future.

Opinions varied widely concerning the need for psychiatrists and psychologists. At some centers, consultation was asked at once. At others, consultation was requested only when it was clearly indicated. At Hammond General Hospital, said Lt. Col. (later Col.) Mark Zeifert, MC, at the paraplegic conference in June 1945, there had not been more than 2 or 3 requests for such consultations during the whole operation of the program. "When a normal person has a fit of depression," he said, "he doesn't send for a psychiatrist. His wife or his children or his friends help him out of it." On a paraplegic ward, the ward officer should be the mental hygienist. "If he isn't," Colonel Zeifert said, "get rid of him and get someone else who is." Paraplegics need help, but it must be given to them casually, almost unprofessionally, by all who come in contact with them.

Colonel Zeifert's approach throughout was bluntly matter of fact. Said he:

We are directed not to use the swimming pool for these patients. Why not? If the paraplegic had been swimming all his life, why shouldn't he use the pool to swim in? He should learn to swim again in the hospital, while he knows someone is there to protect him while he is learning again. If that kind of attitude is taken with respect to all the other natural, normal activities of these men, you can provide them with a natural life. Otherwise, you will end with a biological specimen on your hands.

As the war came to an end, there was a growing realization of the wisdom of this attitude. Lt. Col. John J. Loutzenheiser, MC, stressed it at the Hammond conference. The physical job, he said, was being very well done, but the "song and dance element" should be taken out of it from that time on, and every part of the program should be purposeful, profitable, productive, and designed to fit these unfortunate men for prompt return to a useful, independent life. Dr. Howard A. Rusk's aphorism was more and more quoted, that, "having added years to the lives of traumatic paraplegics, we must now above all add life to their years."

Colonel Kennedy also stressed that rehabilitation of paraplegics should be carried out with imagination as well as competence. Otherwise, he said, quoting Douglas A. Thom, these men would be "* * * * merely living memorials to the skill of medical officers during World War II, but to no good purpose. They must be given something besides just the privilege of staying alive."

To provide that "something" required discipline and a serious purpose as well as solicitous kindness.

PHYSICAL RECONDITIONING

Physical reconditioning of paraplegics began immediately upon their admission to Zone of Interior neurosurgical centers, while they were still bedridden and on Stryker frames. All physical therapy and all exercises, whether conducted in bed, in a wheelchair, or on the mat, were designed to prepare them for the ultimate goal of ambulation. The establishment of this goal was the natural outgrowth of the optimistic spirit which began to characterize the paraplegic centers and the patients in them almost as soon as the new program began to operate.

Physical therapy began with heat. Electrical therapy was not used at all.

Because of the tendency in spastic patients to mass reflexes, all forms of physical therapy were applied with extreme care, and all massage was delicate, especially in patients who already presented these reflexes. The smaller joints were attacked first, beginning with the big toe. If manipulation produced mass reflexes, it was discontinued at once. As experience accumulated and physical therapy was applied with more and more skill, it produced excellent results and was seldom responsible for undesirable reactions.

Physical therapy was always prescribed for paraplegic patients because it was seldom possible to prophesy the outcome in any given case. Passive exercise of the lower extremities was chiefly valuable for reeducation, but there was sometimes a flicker in some muscles, and continued guided exercises occasionally permitted the patient to use a brace for footdrop only instead of a long caliper brace.

Whenever a swimming pool was available, patients were put into it as soon as possible. One of the difficulties here was the practical one of bladder and bowel control, a reasonable degree of which had to be achieved before a common swimming pool could be used.

The widespread interest in reconditioning which had developed throughout the Army by the time the paraplegic problem had been appreciated was adapted to meet the special needs of this group of patients. Experiences of established civilian institutions, such as the New York Institute for the Crippled and Disabled, proved of inestimable value and were fully utilized in the large scale preambulation and ambulation programs finally put into effect in the paraplegic centers.

Specimen Program

How intensive the reconditioning program was and how promptly it was put into effect can be seen in the program set up at the center at Walter

Reed General Hospital, Washington, D.C. All paraplegics on Stryker frames were assigned to the same ward. A single physical reconditioning officer was responsible for these patients. The patients were turned a minimum of 6 times each day, and exercises were conducted in whatever position they were when the instructor entered the ward.

The basic exercises were as follows:

1. Exercises in the supine position consisted of raise and push exercises; leg-stretching exercises; shoulder-blade squeezing exercises, which might require modification for the individual patient; curl and twist exercises; hip-shrigger exercises; and breathing exercises. If bridge-raising exercises, performed with the elbows braced at the sides, were forbidden, chest-raising exercises were substituted. If paralysis was complete, pullups were carried out on the overhead horizontal bar.

2. Exercises in the prone position consisted of raise and push exercises and shoulder-blade squeezing exercises, as in the supine position; leg-stretching exercises, with head rotation substituted if the legs could not be moved; curl and twist exercises, with muscle-testing exercises substituted if arching of the back was contraindicated; and bridge-raising, hip-shrigger, and breathing exercises, as in the supine position.

Group exercises were performed once daily, for 30 minutes at a time, Monday through Friday. Patients were encouraged to perform the exercises on their own initiative a second time each day, and twice daily on Saturdays and Sundays. They were also encouraged to carry out remedial exercises each hour, as prescribed by the physical therapist or the physical instructor. After a patient had regained sufficient strength, he was encouraged to carry out arm and shoulder exercises with dumbbells, to pull himself up on bars, and to perform such other movements as he could (fig. 68).

Since the protective mechanism of pain was not present, great care had to be taken that the exercises were not begun too early and that they were not too vigorous. No patient began exercises until he had been pronounced fit for them by the ward officer and until any precautions necessary had been made a matter of record. The average patient was ready to begin exercises within 3 to 5 months after injury.

Progress notes were maintained for all patients, and precautions were noted on this form. The patients were encouraged to keep a record of their own progress in terms of the number of repetitions performed and the increase achieved in the range of motion.

All exercises prescribed for paraplegics were designed to increase the strength of muscles of the shoulders, arms, hands, back, and trunk for the achievement of balance and the final task of ambulation (figs. 69, 70, and 71).

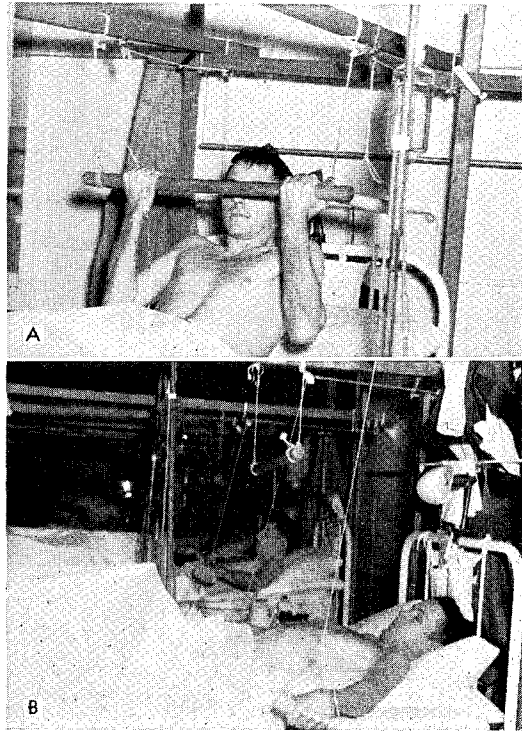

FIGURE 68.—Reconditioning at the colony bed level after control of decubitus ulcers, bladder infection, and nutritional requirements had been achieved in some substantial way in paraplegic patients. A. Simple progressive weight barbell exercises followed by, or carried out simultaneously with, bed-bar exercises designed to further development of shoulder-arm-hand musculature. B. Colony bed exercise allowing full active movement of shoulder-joint musculature.

Results

The reconditioning program was remarkably successful. Under the regimens specifically planned for them, the patients rapidly achieved a considerable degree of physical stability, which fitted them for an out-of-bed existence, whether in a wheelchair or ambulatory. Most of them gained weight. Their mental improvement was even more notable. They were alert and hopeful, and most of them were prepared to go much farther in rehabilitation than had seemed possible when the program was first conceived.

AMBULATION

The chief desire of every paraplegic patient was to be able to walk again, and the first objective of the paraplegic program was to make this desire come true. The entire exercise program, as just noted, was planned with this end in view. Exercises begun in bed were continued in a wheel-

chair and on a mat. Functional activity, such as shaving himself and pulling on his own socks and slippers, was required of each patient from the time he was able to sit erect and balance himself. He was encouraged to take shower baths as soon as possible, with as little help as possible.

In most centers, 70 percent or more of all patients attained some type of gait on crutches and thus became free of a bed or wheelchair existence. Patients and medical officers alike were responsible for the results secured, and it is not too much to say that nowhere else during the war did an earlier attitude of complete defeat meet a more resounding rout than in the ambulation phase of the paraplegic program.

On the other hand, the program was not free from one important error, that in some instances too much was promised. As Col. Loyal Davis, MC, pointed out in one of the discussions of the paraplegic program, it was essential that both profession and laity clearly understand that no paraplegic patient could ever move about freely and that not all patients could be made to walk again.⁶ What could be done for them depended entirely on the level and the nature of the spinal cord injury. It was unfortunate, Colonel Davis said, that in some cases, the psychotherapy which was a necessary part of the management of the paraplegic had been overemphasized and oversold and that in these cases it might very well cause a disturbing and bitter reaction in both the patient and his family.

Braces.—Before the patient could stand and attempt to walk on crutches, he had to be custom fitted with bilateral braces, extending to the upper femoral region or higher (figs. 72, 73, and 74). These braces had to be light enough not to be a drag on the patient, yet strong enough to give him confidence. The hip joint had to be immobilized so that the feet did not drag. When there was little or no function in the abdominal musculature, a thoracopelvic girdle was also necessary (fig. 75).

At some hospital centers, standard braces, obtainable in three sizes, were applied before individual braces were prescribed. In spastic types of paralysis, the braces had to be supplemented by ankle and knee straps, and fitting was, in general, much more rigid than in nonspastic types.

One of the difficulties encountered in the ambulation phase of the paraplegic program had to do with securing and fitting proper braces. There was constant competition with the provision of braces for orthopedic casualties, who were numerous and whose needs were great. The braces supplied were apt to follow the heavy, cumbersome pattern of protective orthopedic devices. Light metals, which would have been ideal for braces, were not available during most of the war, and ambulation was often delayed and was frequently made more arduous because of technical failures in braces. Only in the last few months of the operation of the paraplegic centers were braces of proper design received promptly and in sufficient quantity to care for the paraplegic hospital population.

⁶ Many patients, after they had reached the point of ambulation and savored the satisfaction of the achievement, wisely returned to their wheelchairs.

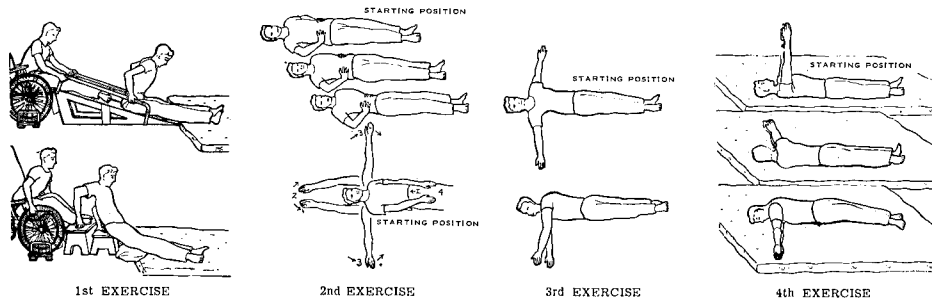

A

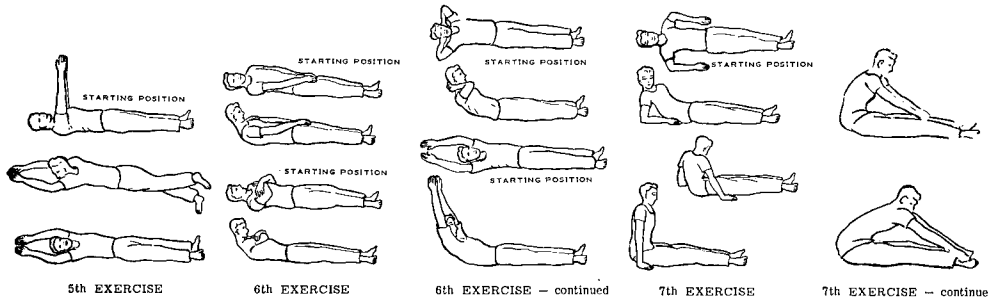

B

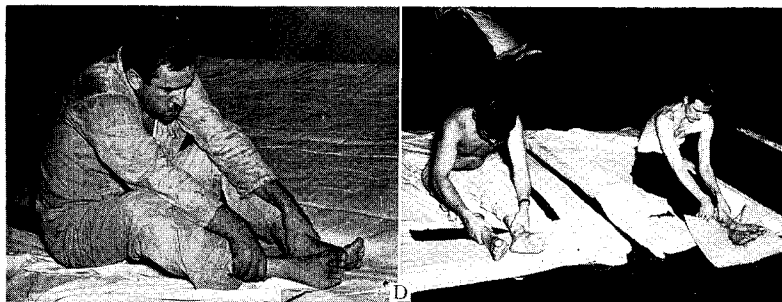
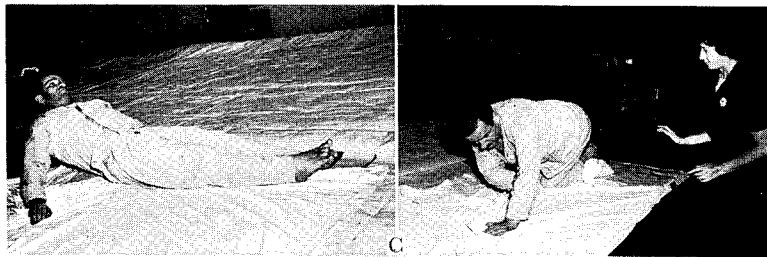
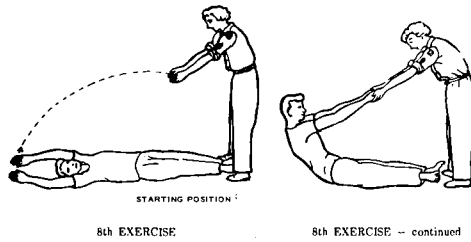
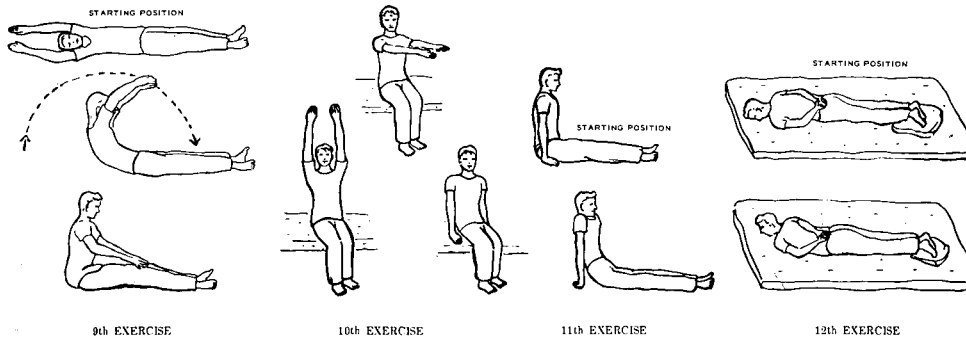

FIGURE 69. (See opposite page for legends.)



E



F

FIGURE 69.—Mat exercises. After adequate shoulder-arm conditioning, ambulation was possible by wheelchair, although bed-chair transport was not readily effected without further training. When ambulation was possible, group exercises could be conducted on mats. The exercises illustrated here represent the fruit of expert supervision, much hard work, and much personal anguish. A. Transport by chair to mat by means of inclined plane or blocks, followed by trunk exercises (exercises 1-4). B. Turning, twisting of the neck, and abdominal exercises (exercises 5-7). These exercises were particularly valuable for patients with spinal transection at lumbar levels. C. Paraplegic patient at exercise at fifth level of reconditioning, showing (1) preliminary position and (2) guidance by trained rehabilitation experts as position is changed. D. Paraplegic patients who have attained full control of shoulder-arm-trunk function after prolonged conditioning in mat exercises. E. Attainment of abdominal muscle and trunk control by paraplegic with low-level lesion (exercise 8). The practical value of these more advanced exercises in relation to personal paraplegic care is apparent, for instance, when the patient leaves his bed. F. Final steps of mat conditioning exercises (exercises 9-12).

Education in Walking

Level of lesion.—The paraplegic patient was graduated as rapidly as possible from mat exercises for the upper extremities and trunk to standing exercises at parallel bars and crutch balancing exercises. Patients with cord lesions at or below the tenth dorsal vertebra were put into braces promptly, without waiting for recovery of muscle function below the lesion. If their upper extremities were intact, the hope of ambulation with crutches could

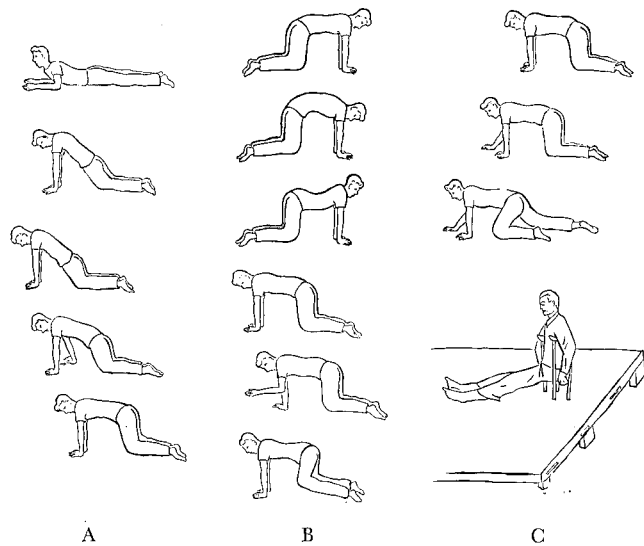

FIGURE 70.—Advanced exercises. With the completion of the simpler mat exercises, paraplegic patients advanced to crawling and modified crutch exercises. These patients must use their arms for ambulation when they transfer from bed to chair, from chair to toilet, from chair to automobile (or even airplane), and when they fall, as they frequently do. A. Arm-trunk lifting exercises, to assume the crawl position. B. Abdominal-trunk exercises. Balancing exercises in anticipation of actual crawling. C. Crawling exercises and first application of modified crutch walking.

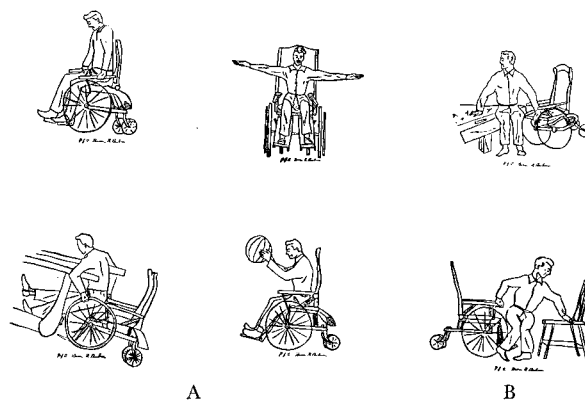

FIGURE 71.—Chair exercises. When paraplegics could begin chair ambulation, group conditioning was facilitated. A. Continuing arm-shoulder play and early ambulation exercises. B. Important chair transfer exercises.



FIGURE 72.—Brace fitting of paraplegic before efforts at ambulation. A. Measurement of long leg brace with low pelvic girdle. B. First fitting of long leg brace for patient with lumbar vertebral injury.

be held out to them. Patients with lesions as high as the second dorsal vertebra, provided the upper extremities were intact, could frequently get about with the aid of braces and crutches, but instruction and practice were likely to be prolonged, and the prognosis had to be guarded. Patients with high lesions, who were unable to use a walker, were promptly put into wheelchairs. They could not walk, but the simple change of posture and the additional exercise of moving the chair proved of great benefit to them.

Rationale of instruction.—Instruction in ambulation was based on certain facts and principles. In transverse myelitis, there are three events, as follows: (1) Loss of motor power, or paralysis, (2) loss of sensation, including loss of proprioceptive power, and (3) disturbance of the autonomic nervous system. Manifestations of these losses are, in turn, (1) disturbances in powers of locomotion, (2) disturbances in the sense of balance, and (3) proneness to trophic changes, including fixation of the joints. The patient is most

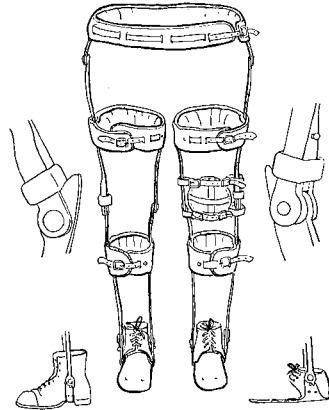

FIGURE 73.—Detail of long leg brace with low pelvic girdle.
Note ankle and knee locks.

greatly handicapped who has lost control of his hip muscles, for with this loss goes a loss of stability in this area.

These losses must be overcome by substitution factors. The first is the use of the muscles of the upper extremity. The second is utilization of the sense of vision. If this sense is used, it is usually possible to train the eyes to achieve balance almost entirely, by teaching the patient to focus on his environment and not on his paralyzed extremities. Once the lower extremities are properly stabilized by braces, the patient develops an awareness of the position of the paralyzed parts and can use his eyes for other purposes.

Techniques of ambulation.—Normal walking is a complicated process, and it was never a simple matter to relearn it to paraplegics. The paralytic gait is fundamentally a succession of alternating movements as the non-weight-bearing extremity is swung forward like a pendulum. Propulsion is obtained by the tripod action of the crutches and the braced lower half of the body. Walking under these handicaps involves swinging the pelvis and lower extremities forward, by action of the musculature of the thoracic cage or the abdomen, with the force transmitted through the braces. Since the gluteus muscle is paralyzed, the patient must lean far to one side or the other to raise the opposite extremity off the ground. This makes for grotesque overmovement at first, and it required long hours of practice to eliminate it.

Two gaits were taught in the paraplegic centers, the step through (fig. 76), which was much harder to learn but which gave the appearance of more normal locomotion, and the swing through (figs. 77 and 78). The latter technique could be learned readily after the first had been mastered, and the patient could then use whichever method best suited his need at the particular moment. The swing-through gait permitted more rapid progress but was more difficult to achieve if taught first; it was best suited for open, unobstructed areas.

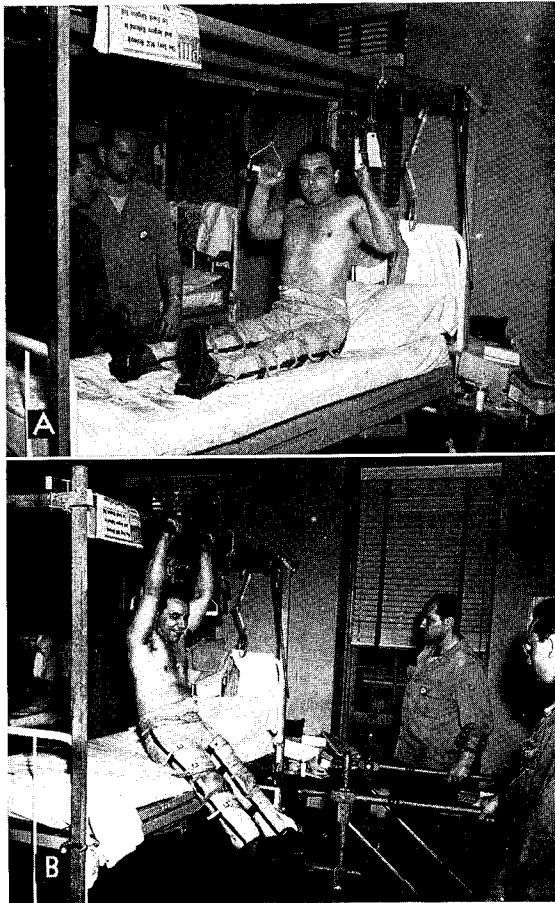

FIGURE 74.—Brace fitting of paraplegic before efforts at ambulation. A. Final fitting of long leg brace. Note advanced conditioning of shoulder-arm-trunk musculature. B. Transition from bed to the first stages of ambulation.

Overhead suspension, which was always kept loose, was used only to protect the patient from falling and to give him mental reassurance. It was not intended to pull him up (fig. 79). It was used chiefly for paraplegics with high thoracic transections and resulting loss of function of the lower abdominal and hip musculature. Ambulation in these patients was better achieved by the use of a wheelchair.

Walkers were useful because they provided a chance to exercise the same muscle groups later used in walking with crutches. They were used chiefly for balancing and stepping exercises and were not intended to replace parallel bars.



FIGURE 75.—Thoracopelvic girdle on paraplegic patient with mid-thoracic spinal cord transection and loss of function of abdominal musculature.

Sidestepping and walking backward were taught to provide the patients with free range of motion. Parallel bars were useful in teaching them to go upstairs and downstairs; going downstairs was taught first (fig. 80).

Crutches were unpadded. Walking with crutches is fatiguing and patients readily developed the habit, if the crutches were padded, of resting on them in the axilla. These patients were going to have to use crutches for the rest of their lives, and it was no kindness to them to permit them to get into bad habits at the start. The way to use the crutches was to rotate them in the axilla, not rest on them.

Walking with crutches was difficult to teach. It meant learning a new and changed balance. Teaching a paraplegic to walk was quite different from teaching a man with infantile paralysis, whose sensory tracts were intact. The patient with infantile paralysis feels when he puts his legs down. The man with a high lesion in transverse myelitis felt as if he were walking on stilts. His point of gravity was completely altered, and he had to be taught to use his crutches, and to think of them, as if they were prolongations of his upper extremities. This was no simple matter.

When the patient had learned to rise from bed to chair, from chair to standing position, from standing position to parallel bars, and from bars to crutches, he was taught to walk on a level surface and then to negotiate stairs. The need for training patients in the use of public transportation

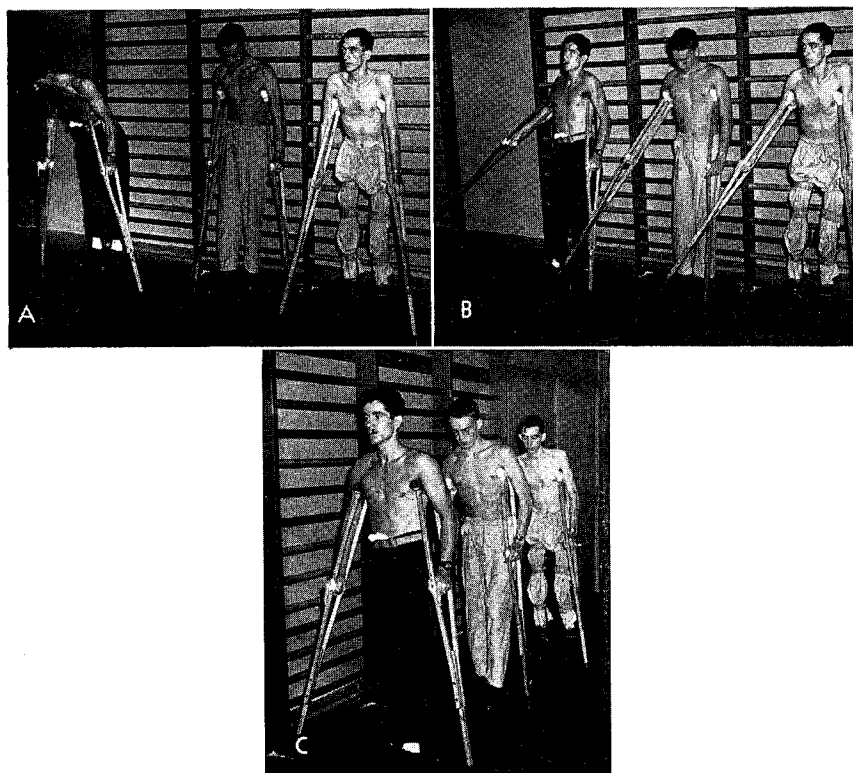

FIGURE 76.—Details of step-through gait. A. Paralytic patients beginning instruction in step-through gait. B. First-stage instruction in step-through gait. C. Walking posture with step-through gait, with gait achieved by alternating movements of ipsilateral extremity and crutch.

ceased to be important when automobiles with hand controls were provided for them. License bureaus in the various States readily granted licenses to these men after they had been instructed in the use of their cars and had passed the required examinations.

A surgical procedure was sometimes necessary before ambulation could be undertaken. The feet had to be at right angles to the leg, and a patient with a fixed equinus of 10° or 15° could not stand up until it was corrected. Paralysis of the calf muscles sometimes remedied the situation, but deliberate lengthening of the heel cord was usually preferable.

Instruction was particularly difficult in spastic paralytics with the so-called scissors gait deformity. Neurectomies and tenotomies were used with advantage in some of these cases, as in spastic children.

Records.—Throughout the whole exercise and ambulation program, it was the custom at some centers to keep charts showing the achievement and time of accomplishment of some 60 activities (fig. 81).

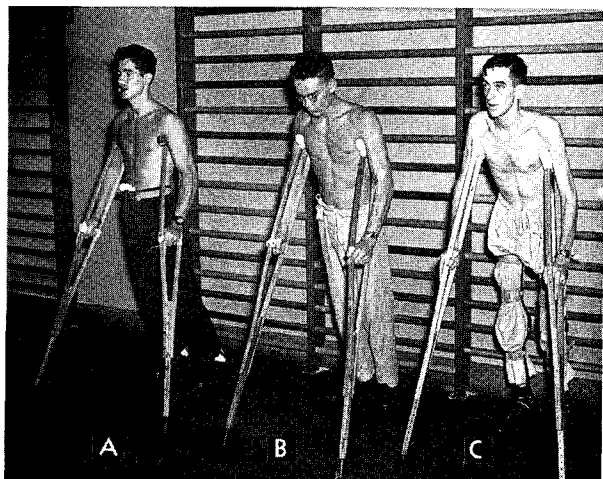

FIGURE 77.—Paraplegic patients shown in figure 76 demonstrating first phase of tripod or swing-through gait. Note detail of following illustrations.

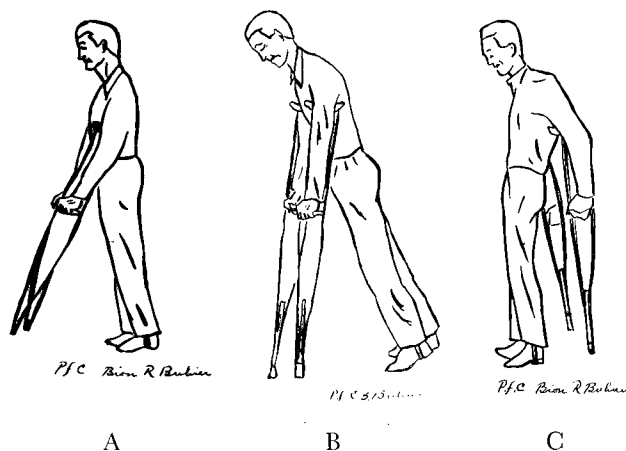

FIGURE 78.—Details of tripod or swing-through gait. A. First or preparatory stage, with tripod formed by feet together and crutches separated. B. Body weight inclined forward over crutches with swing through of paralyzed lower extremities. C. Finishing position of swing-through gait, to be followed by placing crutches in position illustrated in view A.

The competitive aspect of the program improved the general morale, and success in the ambulation program was of great aid in practically every other problem which the paraplegic encountered.

Specimen Programs

Cushing General Hospital.—At the end of hostilities, in August 1945, Col. Condict W. Cutler, Jr., MC, reported that there were 88 patients with cord

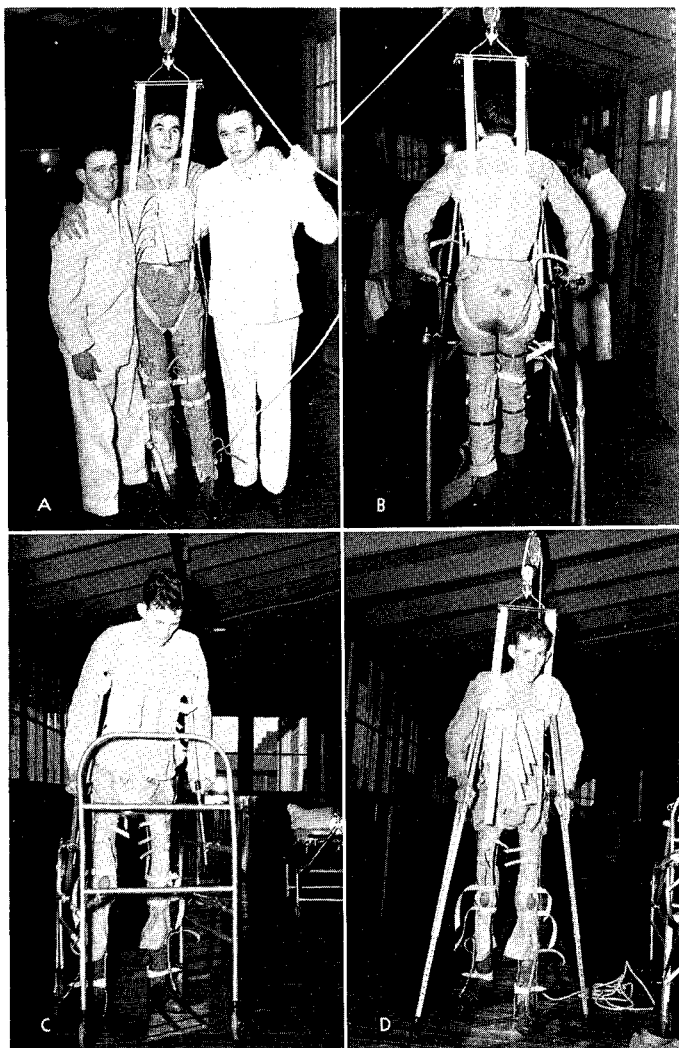

FIGURE 79.—Use of overhead suspension track in early stages of ambulation. A. Patient lifted from transport guerny by means of overhead suspension. B. First stage of ambulation, with use of paralytic walker in step-through gait with overhead suspension. C. Second stage of ambulation, with use of paralytic walker without aid of overhead suspension. D. Third stage of ambulation, with early use of crutches with aid of overhead suspension by paraplegic patient with high thoracic, spinal cord transection.

injuries in the paraplegic center at Cushing General Hospital. They had arrived emaciated, anemic, avitaminotic, incontinent of feces, and afflicted with large decubitus ulcers. By means of transfusions, special alimentation, and vitamin medication, their physical state was brought back to as nearly normal as possible.

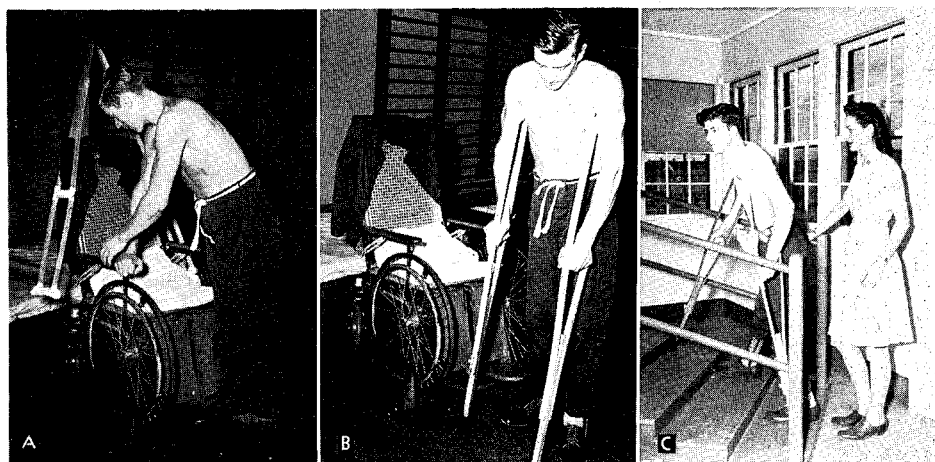

FIGURE 80.—Advanced ambulation with step-through gait in paraplegic patient with low lumbar vertebral injury. A. Movement from chair to crutches. B. Ambulation with step-through gait. C. Training in going upstairs and downstairs.

At first, it was thought necessary to keep paraplegics in bed during treatment of their bladder condition, as well as to maintain the suprapubic cystostomy for long periods. Later, it became apparent that they could be got out of bed earlier than was previously thought possible, and that they would be the better for it. The suprapubic tubes were therefore removed as soon as gross infection of the bladder had cleared up under irrigation. Suprapubic sinuses which failed to close after removal of the catheter were closed surgically. Irrigations were continued at 2-hour intervals through the urethral catheter until cystometric examinations had revealed increasing capacity. Then tidal drainage was instituted and was continued until automatic bladder function had been established. Once this had been accomplished, ambulation could be begun.

Meantime, while the urinary condition was being cleared up, regular exercise of the unparalyzed muscles of the upper body had been carried on, and the patients had been given special instruction in self care.

The orthopedic section of the hospital collaborated in the construction of appropriate braces. When these were applied, the patients attended classes daily for guidance, assistance, and instruction in ambulation. They were provided with special messing facilities. Thanks to the careful preparation for ambulation, the majority of these patients relearned to walk in a remarkably short time.

Hammond General Hospital.—At Hammond General Hospital, Capt. (later Maj.) Ernest H. J. Bors, MC, directed another remarkably successful program (app. C, p. 599). As soon as the patient was admitted, roentgenograms of the spine and evaluation by orthopedic surgeons provided information concerning exactly how much the patient could undertake.

E - EXCELLENT G - GOOD S - SPASTIC		UP ON BRACES						W OR W/O - WITH OR WITHOUT OVER- HEAD SUPPORT.
PATIENT'S NAME	DATE	DATE	DATE	DATE	DATE	DATE	DATE	
	E G S W OR W/O							

FIGURE 81.—Walking record used to follow ambulation progress in paraplegic colony.

A table of measurements was charted, showing the vital capacity and the circumference of the biceps, forearms, and thorax. Measurements were taken every 6 weeks.

Exercises were directed toward strengthening the musculature, including that of the upper extremities and of the thorax, abdomen, and back. They were partly dynamic and partly carried out by squeeze pulleys. Projected crutches (facsimiles) at the bedside were used to prepare the muscles for future motion on real crutches. Other exercises consisted of pull-ups on bars, lifting exercises for the hips and buttocks when the nerve supply of the local musculature had not been impaired, and arching and sitting-up exercises to take care of the back and abdominal muscles.

The patient was trained to become accustomed to a sitting position in bed before he was put into a wheelchair. After he had been in a chair several times, each time for a longer period than the last, the first attempt was made to apply braces and to bring him up into a walker with the aid of the overhead suspension track. This overhead track proved very useful in handling patients for various purposes, including placing them on the toilet and giving them reassurance when they attempted to walk for the first time.

The overhead suspension track was kept on the side porch adjacent to the ward. The patient was brought to it, clad in his corset and braces, and was lifted from the transport guernsey and placed in the upright position. Two sizes of supporting belts, one large and the other small, were connected with the tackle. Both were reinforced by supporting and straddle straps, which permitted comfortable adjustment of the belt and at the same time prevented its slipping. A suspension belt which was too tight simply created respiratory embarrassment.

The patient was then aided by one or two attendants to get onto his walker. As progress was made in ambulation, the overhead suspension was made progressively looser until eventually it could be discarded altogether, the patient then being forced to rely entirely upon the walker and his braces. From the walker, the patient progressed to walking on crutches, at first with the aid of overhead suspension.

When the patient began to try to walk, he was carefully taught how to place his weight in the various motions of walking, and how to use his crutches properly. The tripod position was explained, as well as the alternate use of the left foot and right crutch and the right foot and left crutch.

All phases of walking were supervised by the ward officer, with the assistance of specially trained personnel. A record was kept on each patient to show his progress.

RELIEF OF PAIN AND SPASM

Patients with combat-incurred injuries of the spinal cord practically always had severe pain soon after wounding and for some time thereafter. From a third to a half of all paraplegics had some form of sensory disturbance which was more or less persistent. The discomfort might take the form of a tingling sensation. It might also be moderate or agonizingly severe root pain of segmental distribution. It might also be of the causalgic type and limited to one extremity. Patients with lesions of the conus or of the cauda equina usually had more pain than those with lesions at a higher level; causalgic pain was frequent in lesions at the lower level. Patients with incomplete lesions usually had more pain than those with complete lesions.

The causation of the pain was perfectly obvious in some cases. In others, it was never clarified. Retained foreign bodies in close proximity to pain tracts of the posterior nerve groups explained some cases (fig. 82). Bony overgrowth from healed fractures which impinged on nerve groups was responsible for some cases (fig. 83). Arachnoiditis following trauma to the cord might result in a generalized or girdle type of pain. Involvement of the sympathetic nervous system sometimes resulted in a most distressing type.

Spastic contractures, which were frequently painful, affected about 40 percent of all paraplegics. They usually appeared at intervals varying from 2 weeks to 7 months after injury of the cord.

As with pain, there was no universal explanation for these so-called mass reflexes. The mechanism of the phenomenon was the entrance of sensory stimuli into the spinal cord through a posterior nerve root, and, after their transmission to a large number of anterior horn motor cells, the emergence of these sensory stimuli as efferent stimuli to motor groups. This theory, however, fails to explain why some patients exhibited these spasms and others did not. Some patients with proved transection of the cord might have a minimum motor response to strong sensory stimuli while others

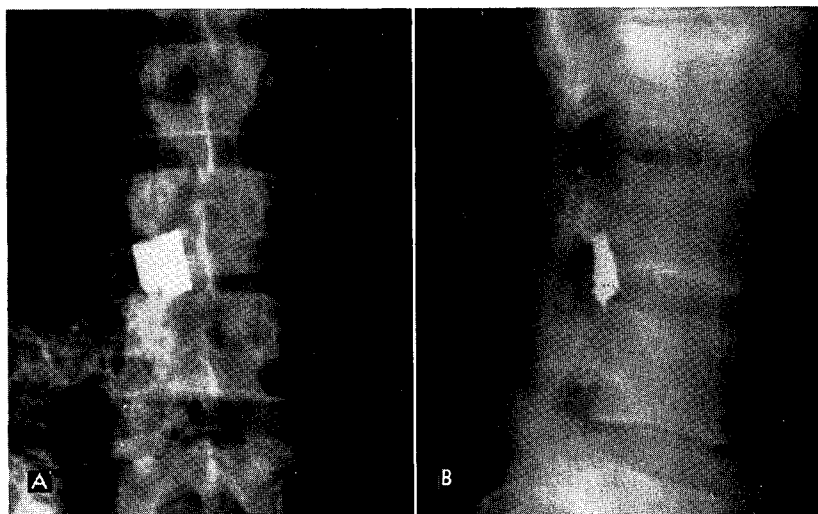

FIGURE 82.—Roentgenograms showing shell fragment partly within spinal canal. A. Anteroposterior view. The foreign body lies on the same side of the midline as the wound of entry in the back, which is a favorable sign. B. Lateral view, showing fractures of vertebral bodies. This observation indicates that the shell fragment has passed completely across the anteroposterior diameter of the spinal canal, which is an unfavorable sign. In this case, however, the dura was found intact at operation.



FIGURE 83.—Roentgenogram showing fistula and exostosis in healing gunshot wound following laminectomy. This patient suffered from persistent posterior nerve-root pain.

with partial transection might exhibit maximum motor response to minimal stimuli.

Whatever the explanation, spasms of any severity in paraplegic patients were incapacitating in the special sense that ambulation and rehabilitation were impossible until they were controlled.

Nonsurgical Measures

Pain tended to decrease spontaneously with time, improvement in the general condition, and increasing activity. In 10 percent or more of all patients, it was persistent enough to require surgical measures for relief, and in most patients, measures of relief were required until spontaneous relief occurred.

Mild analgesics, hot baths, and the distraction and diversion of rehabilitative measures were useful in most cases in the interim. When they were not, more radical measures had to be employed. Morphine could not be used repeatedly for long periods because of the risk of addiction. If the choice lay between it and surgery, there was no question that surgery was better. On the other hand, while paraplegics did not tolerate pain well, they also did not withstand extensive surgical procedures well.

Spontaneous relief of spasm occurred in many patients when they became ambulatory. Physical therapy was always employed, and massage with effleurage and gentle passive motion sometimes achieved good results. Traction was also successful in some cases.

At a number of centers, rather striking success was achieved in the management of painful spasm by the use of the curare. By this time, this agent could be used without fear of the toxicity which had for so long kept it in ill repute, and preparations were becoming available which would hold it in suspension for prolonged periods of time. Results varied from moderate to dramatic. Even the most severe spastics were likely to have periods of relief for 15 to 18 hours or longer; during this time, physical therapy could be carried out and other attempts made to reestablish muscle tone. One patient at McCaw General Hospital who was relieved by this measure had had such severe and persistent adductor spasm that he had developed extensive decubitus ulcers on the knees and a similar ulcer in the groin.

Some striking successes were also achieved by the use of cobra venom in dosages of 0.5 to 1 cc. twice daily. No results were usually observed for 4 or 5 days. Then, as pain diminished, the dosage schedule could be reduced. In 70 of 71 patients with pain and spasm at Bushnell General Hospital, Brigham City, Utah, the results of this measure were so good that no additional medication was necessary except for aspirin and phenacitin. In some hospitals, snake venom and curare were used interchangeably.

Paravertebral block with procaine hydrochloride was tried in some patients with varying results. If adequate relief was obtained, sympathectomy was carried out in some cases, with resection of the first, second, and third lumbar ganglia. The procedure was attended with little risk.

If the pain was segmental and the etiologic factors were obscure or the chances of relief by more direct measures were slight, alcoholic injection of the posterior nerve roots was employed. Paravertebral alcoholic injections were also used in patients with draining wounds or with decubitus ulcers whose location prevented surgical measures. Results were not impressive.

Alcoholic injection into the subarachnoid space and the low sacral region was generally avoided because of the risk of interfering with bowel and bladder function.

Surgical Measures

The neurosurgical task in the Zone of Interior was of diminishing magnitude in the management of paraplegics in comparison with the nonsurgical problems presented by these patients. Surgery, however, was sometimes necessary. Originally, a variety of procedures were employed, as the individual neurosurgeons desired. In TB MED (War Department Technical Bulletin) 162, May 1945 (app. B, p. 589), only the following procedures were authorized:

1. Decompression for excessive proliferation of bone at a fracture site if the process was thought to be responsible for pain and progressive paralysis.

2. Removal of retained foreign bodies or displaced bone fragments in the cauda equina. Exploratory procedures intended only to identify pathologic neural changes were condemned.

3. Appropriate rhizotomy for the relief of radicular pain caused by pressure on the nerve root at the site of injury.

4. Anterolateral cordotomy for the relief of intensive burning pain in completely paralyzed extremities if the lesion was in the cervicodorsal region.

5. Sympathectomy for burning pain, interpreted as a true causalgia and caused by injury to the cauda equina. Patients thought amenable to sympathectomy were to be selected, as already indicated, by preliminary paravertebral block of the lumbar sympathetic ganglia.

In this publication it was emphasized that while pain, progressive paralysis, and mass reflexes associated with intractable flexor spasm and ultimately with flexor contractures were common complications of injuries of the spinal cord, care must be taken to differentiate true neurosurgical difficulties from nonspecific and arthritic pain. It was recognized, however, that the therapy of compound fractures and of amputation stumps of the lower extremities could be severely comprised by the presence of flexor spasm and that relief of spasm was therefore to take precedence over any method of treatment directed at the other injuries.

Laminectomy.—There were a number of arguments in favor of exploratory laminectomy in Zone of Interior hospitals and many regrets when it was officially forbidden. For one thing, it could be done with a minimum risk to life; there were very few deaths and few postoperative complications in the cases in which it was performed.

Another argument in favor of exploratory laminectomy was that the adoption of a conservative policy in regard to it meant that some patients who might be helped by surgery would not have the benefit of operation. Neurologic examination revealed only the extent of physiologic interruption,

not the extent of the anatomic lesion of the cord. The Queckenstedt test as a criterion for surgery was discredited long before the end of the war; the response was normal as long as the lumen of the subarachnoid space was no smaller than the bore of the needle used.

Roentgenologic examination was also not reliable in the selection of patients for laminectomy. Depressed bone fragments were often found in the spinal canal after films had been reported as negative. Even when careful stereoscopic views were made, the fracture of the laminae, the pedicle, or both was often more extensive than the films had suggested. Finally, partial compression of the dura and cord was sometimes found at operation when it had not been revealed by roentgenologic or manometric studies, and decompression often led to dramatic improvement.

Not much neurologic improvement could be expected if laminectomy was unduly postponed. Improvement was evident in 57 percent of 36 patients observed at Newton D. Baker General Hospital on whom laminectomy had been performed within 3 hours to 5 days after injury, against a 10-percent improvement in 386 patients in whom operation had been delayed beyond this period. An occasional patient was benefited by late surgery, but the circumstances were almost always out of the ordinary. In a patient at DeWitt General Hospital, for instance, who had undergone laminectomy because of a block and an incomplete lesion of the cauda equina, evacuation of an absolutely sterile intradural abscess resulted in a moderate amount of function.

All neurosurgeons, in their evaluation of surgery in paraplegia, pointed out that a distinction must be made between operation on the cauda equina and operation on the spinal cord. The cauda equina is essentially a group of peripheral nerves, and its behavior is similar to that of peripheral nerves. It can withstand surgery, and some degree of recovery or relief might be expected after operation on it. Many surgeons noted that exploration of the cauda equina produced about the same results as surgery in certain peripheral nerve lesions. With injuries of the spinal cord proper, however, recovery of function after operation is nothing like as probable.

Rhizotomy.—Experience, which accrued slowly, finally demonstrated that anterior rhizotomy for the relief of mass reflexes in the completely severed cord segment was often useful and sometimes lifesaving (fig. 84). It was particularly useful in injuries of the cauda equina. At operation, the sensory roots were often found glued to the cord or dura by dense adhesions, or partly torn, or adherent to rough bony spicules or fractured bone.

Results were sometimes dramatic. At Newton D. Baker General Hospital, for instance, the operation was done on a patient with such pronounced flexion contractures that he had suicidal ideas. Once his legs were straightened out, his rehabilitation was rapid and gratifying. It was often technically difficult to free the bound-down nerve roots, and scar tissue inevitably re-formed after operation; but, at least while the patients were under observation, results were good in some cases and in some were dramatic.

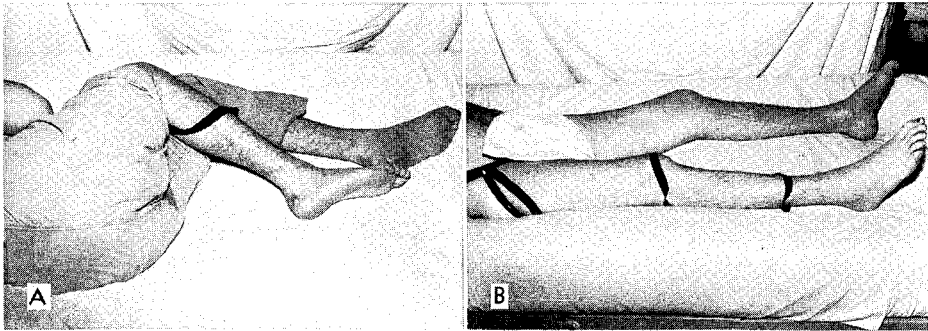

FIGURE 84.—Surgery for relief of spasm and contracture in paraplegic patients. A. Spastic contractures of lower extremities. B. Relief of muscle spasm and contractures after anterior rhizotomy.

Cordotomy.—Cordotomy, with section of one or both lateral spinothalamic tracts, was generally reserved for extreme cases of intractable pain in which rhizotomy had failed. It was a relatively simple procedure technically, and most observers believed that there was little to lose by it. The possible risk of increasing motor involvement and urinary tract impairment was worth taking, since cordotomy usually relieved pain. The operation cannot be done under direct vision, since these tracts are not on the surface of the cord, and some of the pain fibers were therefore sometimes left intact.

Other operations.—Until the limitations placed upon neurosurgical procedures in paraplegics by TB MED 162, a number of miscellaneous procedures were undertaken, and still others were discussed.

If adductor spasm prevented the patient from becoming ambulatory promptly, obturator neurectomy was performed in some hospitals. The results were sometimes poor, but this, it was pointed out, could be explained by the anatomic fact that a small branch of the femoral nerve which supplies the adductor group was frequently overlooked—some surgeons being ignorant of its existence—and failure to cut it permitted spasm to continue.

Section of the cerebral sensory cortex for relief of pain was discussed but was considered applicable only to the very occasional case. Since most patients with transverse myelitis had bilateral pain, both posterior central cortices would have to be exposed, the corresponding areas identified by stimulation, and subpial resection performed. This would have been a very formidable procedure indeed, and, as one observer remarked, it seemed an excellent method of making a paraplegic into a triplegic and giving him epilepsy besides.

Amputation.—Amputation of the legs was the subject of theoretical discussions at several of the paraplegic conferences but was never performed unless the extremities were the site of extensive bone or vascular damage.

There were a number of arguments in favor of the procedure. The legs, which were absolutely useless in complete transection of the cord, weighed

40 to 50 pounds and were perfectly useless in ambulation. Actually, in the new circumstances, they were harmful; they acted as stilts, elevating the center of gravity from the ground for about 4 feet. Against these considerations was the fact that amputation is a mutilating procedure, which a surgeon would not willingly undertake, and that it might merely superimpose a severe psychologic trauma on the severe physical trauma already present. It was also pointed out that a patient with a lesion of the conus could not be fitted with prostheses, for anything that touched the lower extremities caused pressure sores. Amputation for the purpose of using any kind of prosthesis would be defeated by the development of decubitus ulcers.

If amputation should be undertaken, disarticulation at the hip would be more reasonable than midhigh amputation. The patient could then be supplied with a platform, on which he could push himself along.

In these discussions, it was brought out that the literature was devoid of any references to amputation in paraplegics. The sense of the discussions on the subject at the paraplegic conferences was that this was a repugnant procedure, for which there was no indication in paraplegic subjects. The Council on Physical Medicine of the American Medical Association had recommended the operation only if it offered a better prognosis in terms of appearance, comfort, and function, and only if a sufficient part of the extremities possessed enough useful function to work well in prostheses. These criteria were unlikely to be met.

REHABILITATION

Recreation

When paraplegic patients were received in Zone of Interior hospitals, there was a deliberate effort, during the first weeks of hospitalization, to keep them occupied and interested all of their waking hours. A great deal of time was necessarily occupied by medical matters, including attention to decubitus ulcers and to the control of bowel and bladder function. Exercises accounted for another portion of the day, and when ambulation was attempted, training and practice took up still more time. Distracting occupations and entertainment were especially necessary between dinner and bedtime, but occupational therapy, reading matter, games, and other diversions had to be provided continuously. At Hammond General Hospital, it was found most efficient to plan entertainment and occupational schedules for the hours between 1300 and 2100 for a month at a time. Moving pictures, band concerts, and entertainment by show units were particularly helpful.

From the first, an attempt was made to make the men feel that they were still part of the outside world. At McCaw General Hospital, even men with severe decubitus ulcers being cared for on Stryker frames, who could not be moved to wheelchairs, were taken outdoors, to the post exchange, and even to the Saturday night barbecues and the rodeo. Men with bedsores

which had cleared up were allowed 3-day furloughs or passes to visit their families without any redtape at all; they merely told the administrative officer that they wanted to go, and arrangements were made for them to go.

When patients revealed an active interest in music, this was encouraged, particularly the playing of instruments which required strong movements of the diaphragm and the abdominal muscles. The playing of saxophones, trombones, and harmonicas often resulted in significant improvement in abdominal pressure. Music often helped to tide patients over the most trying period of their hospitalization.

The patient's special interests were investigated at almost the first personal interview with him by the ward officer. As soon as the information was secured, it was distributed to those who would be concerned and who could help. The post library produced books. The recreational officer brought records. The special services officer played request pieces over the loudspeaker and dedicated them to the patient. Everyone cooperated in getting him what he was interested in and what he expressed a desire for (fig. 85).

Occupational Training

On the more serious side, as soon as the patient was fit for it plans were made for his reeducation and rehabilitation for a future occupation. At the interview conducted for this purpose, he was questioned about what he had done in the past and what he hoped to do in the future. The approach had to be extremely careful. If a man had been a lumberjack and wanted to return to his former occupation, this was obviously no moment to discuss his future. It was no kindness to build up hopes which later had to be torn down. All of the information thus obtained was used for guidance in the rehabilitation of the patient.

At McCaw General Hospital, much importance was attached to psychologic testing. A profile was made of the patient's abilities as determined on the basis of his performance while he was still on the Stryker frame. The patient was told what these tests showed, and plans for his future were made in accordance with them. It was always necessary to remember that the paraplegic group represented all social and educational levels and that the expression of interest in an occupation was very different from ability to follow it.

Many patients expressed a desire to continue their education, but the Army educational program did not prove useful in this connection. The courses were difficult to obtain, and the few obtained were not suited to the previous education and qualifications of the men who undertook them. Centers which were located adjacent to colleges, such as McCaw General Hospital, were fortunate. Patients were able to attend classes in these colleges, and some of them did the preliminary work for medical and legal training or began to study medicine and law.

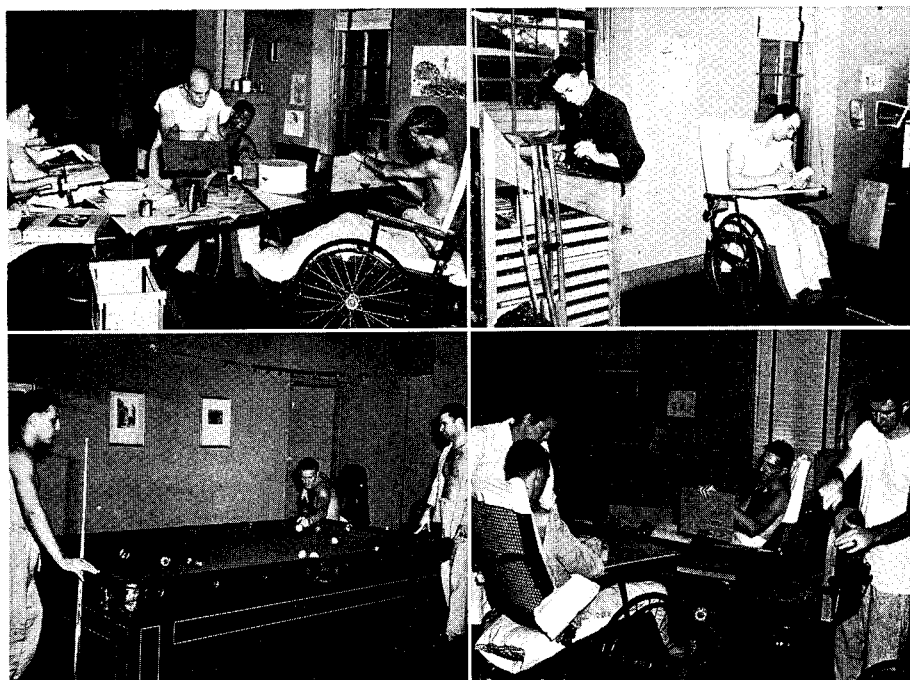

FIGURE 85.—Paraplegics engaged in various kinds of recreation and occupational therapy. These are typical scenes.

The paraplegic survey (p. 14) showed that men who had had the most schooling were most desirous of more schooling. Four out of every five of those with previous college training desired to continue their education. Younger patients more often desired additional schooling than older patients, and patients in the euphoric and normal groups more often desired it than those in the depressed and indifferent groups.

As to occupational training, 70 percent of those who did not desire further schooling also did not desire occupational training. Those with the highest AGCT scores had the greatest interest in securing further occupational training. The euphoric and normal groups had an above-average interest in additional training and the depressed and indifferent groups less than average. Patients to be discharged to their own care or to their own homes apparently had a slightly greater desire for occupational training than those who would require institutional care.

RESULTS OF PROGRAM

The end results of the paraplegic program could not be assessed during the war and must be reported by the Veterans' Administration, to which most of these patients were turned over within the 16 months after the war

ended (p. 13).⁷ A few general comments may be made, however, and a few special instances related.

In speaking of the program at Cushing General Hospital, Colonel Cutler said that in one group of 67 paraplegics, 16 were eventually so improved that they were able to walk. It might be discouraging to reflect, he continued, that the 51 others showed no neurologic improvement in the periods (up to 12 months) in which they were under observation and treatment. On the other hand, all of the patients who remained unimproved from this standpoint had been brought to a tolerable and even a useful existence and all of them proved the entire justification of the new attitude toward spinal cord injuries, as well as its great rewards.

The most successful results from the standpoint of occupational therapy and training were accomplished in work that existed and was not created. In one center, several of the paraplegics worked 4 hours a day, 2 hours in the morning and 2 hours in the afternoon, doing precision work in a nearby factory. They were paid by the hour, punched the timeclock, and lost pay if they were absent or late. Their interest in what they were doing was amazing. One of these men, his ward officer stated, did more to help the morale of the other patients than anybody else, not excluding the Red Cross workers and the Gray Ladies. He gave a practical demonstration that a man with paralyzed legs could still lead a useful life and hold down a paying job, and his determination and cheerfulness did more good than medicine to the other patients.

Many of the men learned new occupations. A patient who thought he wanted to be a rancher ended with a chicken farm. A former truckdriver for a dairy company showed a real talent for leatherwork and was making \$45 a week from it when he left the hospital.

One particularly impressive case history was related by Captain Bors at the paraplegic conference at Hammond General Hospital in June 1945. In fact, the experience with this highly unpromising patient had provided the chief stimulus for the whole plan of management of patients with transverse myelitis at this institution.

This man, the first with transverse myelitis to be received, was a con-

⁷ Statistics of the Veterans' Administration are not available in such form as to permit a followup of the paraplegics who were treated under the program in World War II, but Veterans' Administration Technical Bulletin 10-503, dated 15 Dec. 1948, is of comparative interest. On this date, 35 of 90 paraplegics were attending school and 29 were engaged in business, on-the-job training, or some remunerative hobby. The work tolerances of these 29 patients ranged from 15 to 40 hours weekly, and their monthly earned income ranged from \$100 to \$240. Two patients were earning \$130 and \$155 per month, respectively, while training for future jobs.

As in other studies, this survey showed that patients with injuries at lower levels were more likely to carry out plans for study and work than those with cervical and upper dorsal injuries.

Other facts also had to be taken into consideration in evaluating these results, chiefly the benefits payable to paraplegics at this time. Compensation was \$360 per month. Each man was given an automobile equipped for his driving needs. A home could be purchased at a low interest rate after a small downpayment, and a subsidy could be secured for a specially equipped house, amounting to not more than \$10,000 or not more than 50 percent of the cost. How far these benefits influenced the desire to work cannot, of course, be determined, but their influence cannot be entirely overlooked.

scientific objector. He was rendering aid to casualties on Attu when he was stabbed through the spinal cord by a Japanese soldier. When he arrived at Hammond General Hospital, he was completely paralyzed below the eighth dorsal vertebra and had tremendous decubitus ulcers. He was a depressed, complete invalid, "with no more activity than a jellyfish." He was interested in nothing at all, and daily visits by the commanding officer of the hospital had completely negative results until, after weeks of effort, he became interested in the radio which had been placed by the side of his bed. One thing led to another. Once his bowel and bladder function were regulated and his ulcers cleared up, he was put into a wheelchair and then fitted with braces and taught to walk. He learned to put on his own braces and take them off. He learned to walk up and down stairs.

Meantime, his interest in radio continued, and he became so adept a mechanic that he was termed the "No. 1 radio instructor." He completed his studies at Modesto Junior College, Modesto, Calif., securing the necessary (very high) credits to make him eligible for admission to Stanford University, Palo Alto, Calif., where, when the war ended, he was studying the scientific aspects of radio, with every prospect of a successful career in this field.

The objective of the training phase of the paraplegic program, as 1st Lt. (later Capt.) Edward B. Schlesinger, MC, expressed it, was to provide these men with the complete economic security which they deserved of their country. They were eligible for a pension (then \$150 per month) and for the pay of an attendant (then \$100 per month), but this was not enough. Before they were dismissed from the hospital, they had to be provided with a way to make a living in a dignified, grownup occupation, in some line of work in which they would be given business on their merits and not just because they were crippled.

The point of view of the patients was well expressed by a man treated at McCaw General Hospital, after he had been taught to walk and had completed his first 6 months of legal training at a nearby college. He said: "From the viewpoint of some persons, it seems that it would be more merciful if the terribly handicapped should die. But believe me, living is sweet, and so long as there is a glimmer of hope, there is a chance to live."

There was no better way of providing this "glimmer of hope" than by teaching these paraplegic cripples once more to take their place in the community of normal men.

PHYSICIAN AND PATIENT

The success of the paraplegic program depended fundamentally upon the personal relations between the patient and those who cared for him, particularly the medical officers who cared for him. The cooperation of the patient—which usually had to be secured—was essential. The physician

needed tact and compassion almost more than he needed medical knowledge and skill.

The Relation Between Patient and Hospital Staff

The essence of this relation was well expressed at the paraplegic session at the Newton D. Baker General Hospital in June 1945 by Lt. Col. (later Col.) David H. Poer, MC, who spoke in substance as follows:

The basis of the everyday routine of care for paraplegic patients is the purposeful development of a strong patient-doctor relationship. All matters of every nature, all supervision, all details of management must be the direct responsibility of a single medical officer, in whose charge the patient is placed. This officer must be familiar with everything that happens to the patient and everything that is done for him.⁸ If the ward officer was not interested, neither were the patients.

This relationship is of inestimable value to the patient. He finds that he has a strong post to tie himself to and to spring back from on his road to a reasonably satisfactory mode of life. The time and method by which the officer establishes, builds up, and cements this relationship derive from the daily ward rounds. They must be regular and systematic, and they must be made at least once daily, including Sundays and holidays. Rounds made in the evening are of immense value, since they are usually free from the hurry, bustle, and rush of the average hospital day. During these periods, the patient will discover that the officer not only knows his problems but can point the way to their solution. The complexity of the problems of paraplegic patients requires an unusually time-consuming program, but it pays rich dividends, and they cannot be obtained otherwise.

All personnel responsible for the care of the patients work directly under the authority of the ward officer. The hospital corpsmen and ward attendants are the most important members of the treatment team. Their duties are concerned with the care of bowel and bladder function, with aiding the patients to become ambulatory, with feeding them, and with turning them and caring for their beds. When attendants carry out their duties properly and are sedulous in shifting areas of pressure, Stryker frames promptly become unnecessary.

The work of the technicians who carry out physical therapy blends into the reconditioning program, which is designed to give the man the massive shoulder-girdle musculature required to substitute for motion of the legs. Specially trained urologic technicians or male nurses carry out the simple procedures necessary to keep the urinary tract free from infection.

⁸ Detailed records had to be kept on all patients, and ward officers had different plans for keeping the overall picture of all of their patients immediately at hand. At Hammond General Hospital, a control board in the office of the paraplegic ward informed the ward officer at a glance of the special symptoms of each patient, his progress in the control of bowel and bladder function, his status in regard to ambulation, his participation in ward activities, and all the other details which provided a picture of the patient's mental and physical status at any time.

The Red Cross program is social as well as recreational. Red Cross workers are particularly helpful in the family adjustments which the paraplegic requires. They concern the wife and the children most of all, but they also involve other members of the family. Personal guidance and counsel are provided to take care of all legal and business matters.

Educational and vocational instructors are also needed. The educational program is set up to fit the needs of each patient and is directed toward training him to earn a livelihood after he is discharged.

There is no ward in the hospital in which the chaplain can render more useful service to patients and can be of more assistance to medical officers. Chaplains of all faiths visit the wards daily, and efforts are made to take all patients to chapel services.

Since the original injury is to the spinal cord, the first line of treatment is the responsibility of the neurosurgeon, though the urologist has the chief daily contact with the patient until automatic function of the bladder has been established and infection brought under control. The internist, especially the internist trained in nutrition, has an important role on the paraplegic ward. The results he achieves hasten, and are hastened by, closure of decubitus ulcers. The orthopedic surgeon and the general surgeon also play a part when there are associated conditions or complications.

Behind the medical staff stands the nurse in charge of the ward. She shares with the medical officer responsibility for all details of treatment. She is his listening post and intelligence department. She advises him and supports him and shares with him the supervision of the work of attendants and technicians.

Everything possible is done to convince the patient and his family that he is receiving the most modern treatment possible, that bowel and bladder control will be established, that he will be taught to walk again if this is compatible with his injury, that he will be trained in a gainful occupation, and that he will be dismissed from the hospital as soon as these things are achieved or are achieved to the extent possible. When there is a serious and determined effort to accomplish these results, Colonel Poer concluded, the morale of a paraplegic ward and of the patients in it ceases to be a major problem.

THE PROBLEM OF MORALE

A discussion by Colonel Kennedy at the paraplegic session at Newton D. Baker General Hospital in June 1945 throws a great deal of light on why the paraplegic program in Zone of Interior hospitals was a success. He discussed the specialized personnel needed to deal with paraplegic patients, personnel who had to be specialized not only in their training but in their attitude and their compassion. He spoke of such practical matters as securing special supplies; when ward and other personnel were told they were not available, all of them "should take the attitude that there is no

such answer as 'No' to their needs." He thought that officers might get better treatment, and progress more rapidly, if they were put in the paraplegic wards along with enlisted personnel. He wondered whether it might not be practical to keep in service certain paraplegics who could demonstrate to other patients what could be accomplished in this condition.

Then Colonel Kennedy spoke of the morale of paraplegic patients. He said that originally, in his own hospital (Percy Jones General Hospital), the patients had come in rapidly and their morale was poor. Since the program had developed, the morale in the paraplegic ward was better than in any other ward in the hospital and he thought the following story might explain it:

Among the 600 patients in this neurosurgical center were 41 paraplegics, 39 of them enlisted men. A few days before Christmas, the officer on the paraplegic ward went to the commanding officer of the hospital and said, "We've got 39 men over there in the paraplegic ward. Christmas is coming and many of these men have their families here. I don't know whether they'll be alive next Christmas but they're here this Christmas and I want every one of these men to have their families here for Christmas dinner." The answer was "No." Said the young lieutenant, who had been in the Army all of 4 months, "Sir, I demand that these men be allowed to have their families here for Christmas. These men deserve it. They have given everything to their country. They deserve to have their families here, and, damn it, they're coming to dinner."

The end of the story is that there were 140 on the ward for dinner Christmas day. The Red Cross set up bridge tables at each bedside, with gay tablecloths, candles, and comfortable chairs. Enlisted men, WAC's, and nurses from other wards volunteered to serve the dinner. Presiding most graciously over the affair, and the most pleased person on the ward, was the commanding officer of the hospital.

One need not go beyond that story to know why, in that hospital center and in others, the morale of paraplegic men was high and why the program, founded on compassion as well as on technical competence, put courage and hope into the hearts of soldiers who otherwise would have had no reason to keep on living, let alone striving to create a new existence for themselves.

CHAPTER VIII

Management of the Ruptured Intervertebral Disk (Herniated Nucleus Pulposus)

R. Glen Spurling, M.D.

HISTORICAL NOTE

The condition known as rupture of the annulus fibrosus with herniation of the nucleus pulposus (more commonly spoken of as ruptured intervertebral disk) furnished no problem in World War I, since at that time the syndrome was unknown, at least as such. Its clinical importance began many years later, with Mixter and Barr's¹ first publication on the subject in 1934. There is no doubt, of course, that, had this knowledge been available earlier, numerous obscure and puzzling complaints related to the back would have been explained as ruptured disks in World War I.

By the time the United States entered World War II, the classical clinical picture of the ruptured intervertebral disk was well established, and diagnostic methods had become reasonably well standardized. The errors inherent in air myelography had been pointed out, and the value of Lipiodol studies, as well as their difficulties and dangers, had been clarified. The introduction of iophendylate (Pantopaque) in 1940, by Strain, Plati, and Warren,² was particularly well timed. Pantopaque was to prove a useful and innocuous agent, and contrast myelography with it furnished the solution of numerous diagnostic problems. Finally, hemilaminectomy and interlaminar resection of disk tissue had become common practice following the development of these operations by a number of neurosurgeons. In 1938, Love and Walsh³ had reported 100 surgical cases.

Followup studies on adequate numbers of surgical patients in civilian practice had shown conclusively that, if the cases were properly selected and if careful protection was provided for the lower lumbar region over a considerable period of time, half or more of all patients would be completely relieved of their symptoms, while another large group would receive almost

¹ Mixter, W. J., and Barr, J. S.: Rupture of the Intervertebral Disc With Involvement of the Spinal Canal. *New England J. Med.* 211: 210-215, 2 Aug. 1934.

² Strain, W. L., Plati, J. T., and Warren, S. L.: Iodinated Organic Compounds as Contrast Media for Radiographic Diagnosis. Iodinated Aracyl Esters. *J. Am. Chem. Soc.* 64: 1436-1440, June 1942.

³ Love, J. G., and Walsh, M. N.: Protruded Intervertebral Disks; Report of One Hundred Cases in Which Operation Was Performed. *J.A.M.A.* 111: 396-400, 30 July 1938.

complete relief. Perhaps most important of all, it had been shown that eventual return to ordinary activities was possible in most of the successful cases.

DEVELOPMENT OF CLINICAL POLICIES IN THE ZONE OF INTERIOR

The management of herniated nucleus pulposus was to prove a major responsibility of neurosurgeons in Zone of Interior hospitals in World War II. From the standpoint of numbers, this lesion was exceeded only by peripheral nerve injuries.⁴ From the military standpoint, it accounted, in the aggregate, for a very considerable loss of manpower-days.

Policies of management were arrived at by evolution as the importance of the ruptured disk syndrome became clear and as it became apparent that the methods of management which had proved correct and highly successful in civilian practice could not be applied in military practice.

Classification of Patients

Patients with ruptured lumbar disk in Zone of Interior hospitals fell into three categories, as follows:

1. Many men were inducted with the disability, in spite of the military regulation that provided that no person was to be inducted with a history or physical findings suggestive of such a lesion or with a history of surgery for it.⁵ When questions of disposition arose, men in this group were considered Line-of-Duty-No.

2. Many men without a previous history of herniated nucleus pulposus developed the condition under the wear and tear of routine military service. At Kennedy General Hospital, Memphis, Tenn., special studies by Maj. (later Lt. Col.) Fritz J. Cramer, MC, showed that it might be the result of acute trauma. At post mortem studies, protruded intervertebral disks were found directly opposite lesions present in the spinal cord, and violent protrusion of the disk, due to compression of the nucleus pulposus or its herniation, was proposed as a true mechanism for producing injuries of the spinal cord with traumatic paralysis. When questions of disposition arose, men in this group were considered Line-of-Duty-Yes.

3. A considerable number of men were returned to Zone of Interior hospitals when the original policy which permitted surgery overseas was altered and operation was no longer permitted in oversea theaters.

⁴This was true throughout the war and after the fighting ended. A report from Halloran General Hospital dated 7 Dec. 1945 showed that in the preceding 6 months, 2,277 patients had been admitted to the neurosurgical center; 1,518 had peripheral nerve injuries, 229 craniocerebral wounds, and 369 signs and symptoms indicative or suggestive of ruptured disks. During this period, 253 myelograms were performed, and 58 of the 908 operations were for ruptured disks.

⁵War Department Mobilization Regulations No. 1-9, 19 Apr. 1944. Section X. Spine, Scapulae, and Sacroiliac Joints.

Early Policies of Management

The importance of herniated nucleus pulposus in young men subjected to the unaccustomed rigors of Army life became evident early in the war. A considerable number of operations for it were done by Maj. (later Col.) R. Glen Spurling, MC, at Walter Reed General Hospital, Washington, D.C., in which the first neurosurgical service in an Army hospital had been established in the spring of 1942. Almost at the same time, the Society of Neurological Surgeons discussed the problem in detail at its annual meeting, and Dr. W. Jason Mixter, acting for the society, raised the question of their management with Col. (later Brig. Gen.) Fred W. Rankin, MC, Chief Surgical Consultant, Office of the Surgeon General. In his letter to Colonel Rankin, Dr. Mixter pointed out that it was the sense of the society that it was not possible to be dogmatic about the type of treatment to be given to army personnel suffering from ruptured disks. Inquiries to Canadian neurosurgeons had revealed the same indecision concerning the management of army personnel.

Dr. Mixter proposed that certain Army (and Navy) hospitals be designated for the management and study of this condition; that patients be referred to these hospitals only after careful selection and screening according to a specified routine; that the services be in charge of competent neurosurgeons, with a special interest in herniated nucleus pulposus; and that the myelographic and surgical management of these patients follow the same standard technique in all hospitals. Special emphasis was placed upon proper screening, to prevent the designated hospitals, as Dr. Mixter expressed it, "from becoming a dumping ground for every lame back in the Army."

Colonel Rankin was in general agreement with these proposals, except that he believed it important that each neurosurgical center in which patients with ruptured disks were to be treated should have a close relation with an orthopedic service. The original suggestion, that a neurosurgeon and an orthopedic surgeon examine each patient before he was sent to a neurosurgical center, was not considered practical, and a form was drawn up (fig. 86) which could be submitted to the center and on the basis of which the patient would be accepted or rejected.

The establishment at about this time (the summer of 1942) of neurosurgical centers in several general hospitals made the establishment of special services for the management of ruptured disks no longer the urgent matter which it had been originally, but the plan which had been proposed was, in general, followed, as is evident in the instructions contained in Circular Letter No. 43, Office of the Surgeon General, 13 February 1943.

Selection of cases for surgery.—In this letter, it was pointed out that herniated nucleus pulposus had become a major military problem, which required the joint attention of orthopedic surgeons and neurosurgeons.

SPECIAL EXAMINATION OR ADDITIONAL DATA LOW BACK PAIN CHART*	
Name	Grade
Ward	
Line of Duty	
Civilian Compensation Claim: Yes ... No ...	
HISTORY: Trauma: No ... Yes ... Type	
Back Pain: Date of onset	
No. of recurrences in civil life	
In Service	
Location	
Character	
Duration (No. of months)	
Intensified by: Bending Lifting Coughing Straining	
Relieved by: Lying down Walking Immobilization (type)	
Leg Pain: Date of onset	
No. of recurrences in civil life	
In service	
Location: Right Left Bilateral	
Character	
Pattern: Radiation to hip Knee Calf Foot	
Intensified by: Coughing Straining Bending Sitting	
Relieved by: Lying down Flexing thigh Walking	
Sensory disturbances:	
Numbness	
Tingling	
Coldness	
ADDITIONAL HISTORY (Record any familial history of arthritis or back symptoms, etc.):	
EXAMINATION: Weight In relation to height and age	
Gait: Smooth without limp Limp (describe)	
Upper Extremity:	
Signs of arthritis: Shoulder Elbow Wrist Fingers	
Atrophy Weakness Sensation Reflexes	
Trunk:	
Lumbar lordosis Reversal on forward bending	
List: Right Left Pelvic tilt	
Muscle span	
Percussion tenderness	
* Key: N = Normal; O = Absent.	
Radiating percussion pain	
Lateral bending test:	
Toward painful side	
Away from painful side	
Hyperextension test	
Spinal Mobility: Flexion Lateral	
Extension Rotation	
Lower Extremity:	
Length (A.S.S.-I.M.): Right Left	
Circumference: Thigh Right Left	
(Atrophy) 10"	
Knee Right Left	
Calf Right Left	
Sensory changes: Hypesthesia	
Paresthesia	
Motor changes:	
Reflexes:	
Knee jerk Right Left	
Ankle jerk Right Left	
Plantar response Right Left	
Straight leg raising test Right Left	
Lasegue test Right Left	
Jugular compression test	
Feet: Normal Relaxed arches	
Pronation Circulation	
PERSONALITY APPRAISAL: Mental level Stoic Hypochondriac	
CLINICAL DIAGNOSIS:	
EXTENT OF PATIENT'S DESIRE FOR RELIEF:	

A

B

FIGURE 86.—Special form developed for use in cases of ruptured intervertebral disk and other cases of low back pain. A. Front of form. B. Reverse of form.

Prompt and appropriate treatment would permit the return to duty of these patients within a few weeks.

Characteristic clinical manifestations were listed as low back pain; unilateral sciatica; limitation of motion of the lower back; pain on percussion over the lumbar spine, with radiation into the hip and leg; increased pain on hyperextension of the lumbar spine; hypesthesia and paresthesia of the foot and leg on the affected side; absent or diminished ankle jerk on the affected side; and a positive jugular compression test.

Great discretion was to be exercised in the selection of patients for transfer to neurosurgical centers. Operation was to be performed only in these centers, and the line-of-duty status of the patient was to be evaluated before it was undertaken. If the man had had episodes of pain and disability referable to the lower back before induction, the condition was to be considered Line-of-Duty-No, and operation was to be performed only in exceptional circumstances. Low back pain or disability was considered an indication for operation only under exceptional circumstances even in Line-of-Duty-Yes cases; the chief indication for disk surgery was intractable sciatic pain.

In Circular Letter No. 190, Army Service Forces, Office of the Surgeon General, 17 November 1943, instructions were given for the careful selection of patients with preinduction disabilities for elective surgery. Such operations were to be considered only for men with conditions which past experience had shown to be readily correctible and then only if return to full military duty would be possible within a relatively short time. They were not to be considered for defects which would require prolonged hospitalization or in which the liability of recurrence or failure was great. This circular letter further pointed out that no individual with a preinduction disability was to be considered for elective surgery unless he gave particular promise of being of future value to the Army from both the mental and the physical standpoint. Herniated nucleus pulposus was listed as among the preinduction defects in which surgery would not ordinarily be justified.

Myelography.—Myelography was recommended for diagnosis and for localization of the disk lesion if clinical findings were not adequate for these purposes. It was not to be performed, however, outside of neurosurgical centers, to which patients were to be transferred for investigation and treatment only after a judicious selection.

Preliminary studies of the clinical reaction to Pantopaque had demonstrated its safety for clinical use, and subsequent experiences with it confirmed the initial impression (fig. 87). The myelograms proved remarkably accurate in the more than 200 cases first investigated by this technique at the

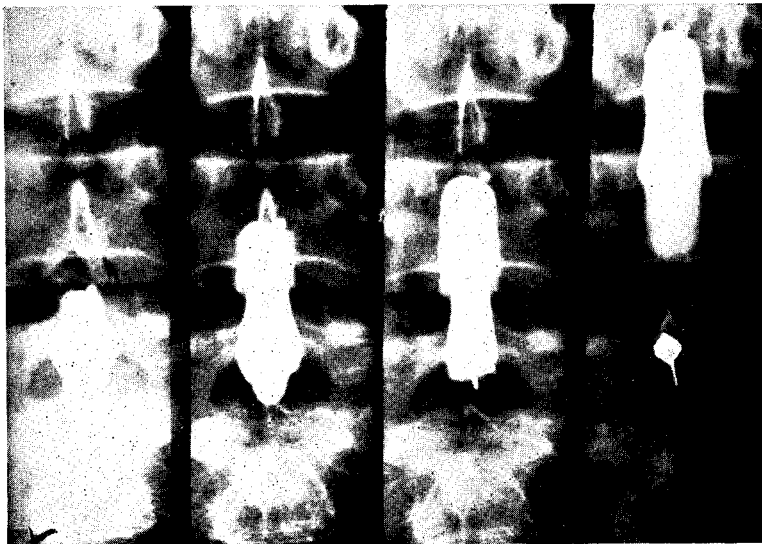

FIGURE 87.—Serial Pantopaque myelogram, with lumbar puncture needle at L₅, showing no abnormalities. Reading from left to right, note smooth opaque column and symmetrical axillary pouches at L₅, L₄, L₄, and L₃.

neurosurgical center at Walter Reed General Hospital. Spot films made with a grid showed precise detail. Dural sleeves and axillary pouches were usually completely outlined, and not infrequently the whole course of the nerve root at each level could be shown. Use of this method therefore became routine to verify the clinical diagnosis before operation was advised and to localize the lesion accurately, so that, at operation, the removal of the damaged disk could be accomplished with the least possible disturbance of the weight-bearing mechanism of the spine (fig. 88).

Untoward reactions never followed the use of Pantopaque if it was removed immediately after the examination. If, for any reason, it could not be completely aspirated, the reaction was no more serious than when Lipiodol was used. The whole procedure, in the hands of an experienced neurosurgeon, including the time necessary for the injection and aspiration of the Pantopaque, did not require more than 15 to 20 minutes.

It was the policy with Pantopaque, as with other contrast mediums, not to attempt myelography until a week or more after diagnostic lumbar puncture. Later, it became the policy not to remove the spinal fluid for examination until after the myelogram.

Later Policies of Management

Statistical studies.—Statistical studies for the year 1943 indicated the magnitude of the problem of herniated nucleus pulposus among Army personnel as well as the results of the policies then in effect (table 4). The approximately 2,400 cases observed among enlisted and officer personnel in the continental United States represented an admission rate of about 0.5 per thousand strength for enlisted men and a slightly higher admission rate for officers, who constituted about 11 percent of all patients hospitalized for this cause.

TABLE 4.—*Status, about 1 August 1944, of sample of patients admitted for herniated nucleus pulposus in 1943*

Operations performed during 1943	Enlisted personnel			
	Total cases in sample	Still in service 1 Aug. 1944	Discharged up to 1 Aug. 1944	Percent discharged
None.....	328	72	256	78
Excision of herniated nucleus pulposus (including laminectomy).....	126	87	39	31
Miscellaneous or unknown.....	29	7	22	76
Total.....	483	166	317	66

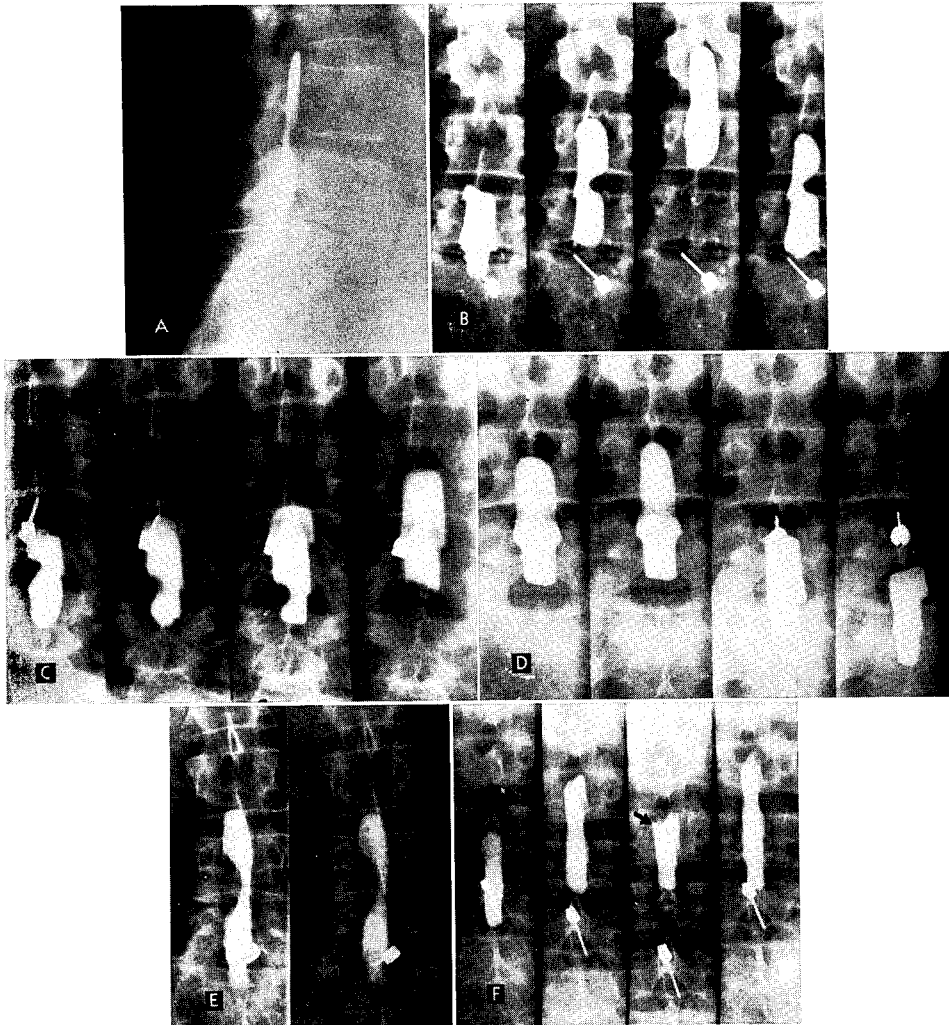

FIGURE 88.—Pantopaque myelograms. A. Lateral view showing anterior defect in opaque column at L_4 and narrow lumbosacral disk. The lumbar puncture needle is at L_5 . B. Serial myelogram showing defect characteristic of ruptured disk at L_4 on left. Lumbar puncture needle is at L_5 . C. Serial myelogram showing filling defect characteristic of lumbar ruptured disk at L_5 on right. Lumbar puncture needle is at L_4 . D. Serial myelogram showing minimal changes characteristic of lateral ruptured disk at L_5 . Note that the axillary pouch at L_5 is well shown on the right, while the one on the left fails to fill. E. Myelograms showing large filling defect on left characteristic of tumor of cauda equina. The neoplasm proved to be a neurofibroma. F. Serial myelogram with demonstration of filling defect (shown by arrow) at L_3 as column progresses upward. Note that the defect is obliterated when the third interspace is completely covered by the opaque material. The lesion proved to be a ruptured intervertebral disk at L_3 .

The results of surgical treatment as analyzed in an approximately 20-percent sample of these cases in August 1944 compared favorably with the results of surgical treatment in civilian practice. The discharge rate of 31 percent for enlisted personnel treated by surgery compared very favorably with the discharge rate of 78 percent for patients treated conservatively. In a sample of 59 officers, 50 were still in service—32 who had been treated surgically and 18 who had not. Nine (15 percent) had been discharged. This separation rate corresponded quite well with the results at the neurosurgical center at Walter Reed General Hospital, where less than 10 percent of the officer personnel with ruptured intervertebral disks had been separated from service for this reason.

These statistics seemed to indicate that the neurosurgical management of herniated nucleus pulposus during 1943 had been effective in attaining the major objective of all medical treatment of Army personnel, that is, rehabilitation of the patients for duty. On the other hand, although this conclusion seemed fully justified, it had to be weighed in the light of two highly favorable extraneous factors which were operative during 1943. The first was the pressing need of the Army for manpower, as a result of which there was considerable pressure on medical officers to expedite the return to either full or restricted duty of all men capable of service. The second was that the sample contained a relatively large group of officers, whose incentives for return to duty were greater than those of enlisted men and who presented, therefore, few problems of rehabilitation.

The situation in respect to officers continued relatively favorable throughout the war. During the latter half of 1944, however, and the first months of 1945, the whole picture of herniated nucleus pulposus underwent a considerable change. The story at the neurosurgical center at O'Reilly General Hospital, Springfield, Mo., was typical. Early results of surgery were extremely encouraging. Later, they became less rosy. Some men who had been returned to duty on a limited service status after a period of convalescence were coming back with recurrent symptoms. Others who had been operated on elsewhere were being referred to this center for evaluation. There was no doubt, in short, that the results of surgery for ruptured disk in military practice were by no means as good as they were in civilian practice. The belief was also growing that practically all patients with ruptured disks, whether or not the disability existed before induction, were likely to have their symptoms aggravated by military service, and that line-of-duty evaluation should therefore play practically no part in the decision for or against operation.

War Department Circular No. 212, 29 May 1944, specified that if an enlisted man could not "perform a reasonable day's work for the Army," his retention was wasteful and he should be discharged. Many, if not most, of the men operated on for herniated nucleus pulposus were covered by this regulation, which was quickly reflected in the results of surgery. Increasing

difficulty was experienced in accomplishing alleviation of symptoms, in contrast to the numerous good results formerly secured promptly.

An additional reason for the deterioration in surgical results was, paradoxically, the excellent reconditioning system which had been introduced. However desirable it was in its general application, it proved ill adapted to patients with low back disabilities. Practically all patients with disk lesions responded unfavorably to it, and many of them had to be rehospitalized because their symptoms were reactivated. Similar observations were made in the reconditioning centers in the United Kingdom Base.

To determine the then current status of patients with herniated nucleus pulposus who had been operated on in 1943 (table 5), a reevaluation of an approximately 20-percent sample was undertaken in March 1945 (table 6). The proportion of discharges after surgery was found to have risen from 31 to 56 percent, while the total separations after surgery had risen from 66 to 83 percent. In all probability, these increases reflected not only the influence of personnel requirements of the Army upon this special neurosurgical problem but also the actual inability of patients with this type of lesion to withstand the difficulties and hardships of Army life.

Final Policy Changes

War Department Circular No. 209, 13 July 1945, took cognizance both of the change in Army manpower requirements and of the long-term unsatisfactory results, at least from the military standpoint, of surgery for herniated nucleus pulposus. In a more realistic approach to the problem, the following policy was outlined for the management and disposition of patients with this condition:

TABLE 5.—Cases of herniated nucleus pulposus (continental United States) operated on in 1943 among approximately 20 percent of Army strength during that year

Cases admitted	Total	Method of treatment	
		Excision or laminectomy	No operation
Enlisted men.....	450	133	317
Male officers.....	62	39	23
Females.....	8	4	4
Total.....	520	176	344

1. All patients with a diagnosis of herniated nucleus pulposus established as not in line of duty were to be treated conservatively and then separated from service in accordance with current military directives unless they desired surgery for intractable pain or there was evidence of neural paralysis.

TABLE 6.—*Status, about February 1945, of cases, shown in table 5 of herniated nucleus pulposus*

Status	Total	Method of treatment	
		Excision or laminectomy	No operation
Enlisted men:			
In service.....	90	50	40
Separated.....	360	83	277
Percent separated.....	80	62	87
Male officers:			
In service.....	44	28	16
Separated.....	18	11	7
Percent separated.....	29	28	30
Females:			
In service.....	5	3	2
Separated.....	3	1	2
Percent separated.....	38	25	50
Total:			
In service.....	139	81	58
Separated.....	381	95	286
Percent separated.....	73	56	83

2. Military personnel who developed ruptures of the intervertebral disk in line of duty were to be treated with the objective of achieving maximum hospital benefit. Treatment was to be by conservative methods or, if the patient desired it, by surgery. After maximum hospital benefits had been attained, disposition was to be in accordance with current directives.

3. The "inherent repetitive character" of the syndrome of herniated nucleus pulposus was to be closely examined in determining the line-of-duty status in each individual case.

The war ended before the new policy could be put into effect and its advantages and disadvantages tested.

DEVELOPMENT OF CLINICAL POLICIES IN OVERSEA THEATERS

The Mediterranean Theater of Operations

Early in the Tunisian campaign, it became apparent that operations for ruptured intervertebral disk were, on the whole, not satisfactory in an oversea theater. The immediate surgical results were usually good, but it was difficult to get the men back to duty, and, if they could be returned, difficult to keep them there. It therefore became the policy to evacuate men with this condition to the Zone of Interior if they could not perform full or limited duty in the theater. Operation overseas was permitted only in

exceptional cases, and then only on written recommendation of the disposition board of a general hospital.

In practice, this policy worked out so that operation was performed overseas only in the following special circumstances:

1. The patient was in extreme pain, and the long delay entailed in a return to the Zone of Interior would have worked considerable hardship on him.
2. Pain, although intermittent and continuous, had not been relieved by short periods of rest and was resulting in debilitation. The diagnosis of ruptured intervertebral disk in this group of patients had to be absolutely clear cut.
3. The patient was of particular value to the Army in the oversea theater.
4. The patient himself desired the operation, in order to be able to return to his unit, in which his work would not be unduly strenuous.

When these various criteria were strictly observed, operation for ruptured disks in the Mediterranean theater usually gave good results.

The European Theater of Operations

It was originally the policy in the European theater to perform surgery for ruptured intervertebral disk whenever it seemed likely that the patients could be rehabilitated for duty. Operation was performed only in a general hospital, only by a neurosurgeon, only after the chief of the orthopedic service of the particular hospital had excluded (in a numerical listing) all other conditions as possible causes of the symptoms, and then only after approval by the theater senior consultant in neurosurgery or orthopedic surgery.

Under these strict regulations, the number of surgical cases was small. In June 1943, Col. Loyal Davis, MC, then senior consultant in neurosurgery, reported that only 29 operations had been done in the theater up to that time; 11 patients had been returned to full duty and 5 to limited duty, but sufficient time had not elapsed to determine end results. By March 1944, however, it had become evident that only a small percentage of surgical patients were likely to recover sufficiently, and within a reasonably brief time, to return to full duty.

Furthermore, as preparations for invasion of the Continent were intensified, the permitted period of convalescence for elective surgery was reduced to 4 weeks at a maximum. Since disk lesions obviously could not be handled under such a limitation, neurosurgeons in the theater were instructed to operate for this condition only if the soldier was classified as essential and then only if he could be expected to return to his former duties without an unduly long convalescence. Patients who did not qualify for surgery under these criteria were treated conservatively for a period of about 2 weeks, and, if they had not responded satisfactorily to treatment by the end of this time, were evacuated to the Zone of Interior.

Part II

PERIPHERAL NERVE INJURIES

CHAPTER IX

Historical Note

Barnes Woodhall, M.D.

PERIPHERAL NERVE INJURIES IN WORLD WAR I

The experiences of neurosurgeons with injuries of the peripheral nerves in World War I were recorded at length and in a variety of ways. Although the American experience was limited because of the relatively brief duration of U.S. Army combat experience, there is a long, complete, and excellent discussion of these injuries in the official history of the Medical Department.¹ Huber's valuable neuropathologic studies are included in detail. The British experience with peripheral nerve injuries appeared in the periodical literature while the war was in progress, and an excellent and representative summary by Platt and Bristow appeared in the *British Journal of Surgery* in 1924.²

The World War I experience and the lessons derived from it were also recorded in a number of texts, the most important being those by Benisty,³ Tinel,⁴ Stookey,⁵ and Pollock and Davis.⁶ Pollock and Davis' book was well known to both general surgeons and neurosurgeons before the outbreak of World War II, and during the war, it was destined to attain a high place of respect and actual affection in the minds of military neurosurgeons.

It is extremely unfortunate that the official history of the U.S. Army Medical Department in World War I was not made readily available to military neurosurgeons in World War II. It should have been required reading for them and for other military surgeons. It contains fundamental information on peripheral nerve anatomy and on technical methods of nerve exposure, mobilization, transplantation, and suture. Had they possessed this fundamental knowledge, military surgeons untrained in neurosurgery but required by the necessities of war to learn rapidly how to treat peri-

¹ The Medical Department of the United States Army in the World War. Washington: Government Printing Office, 1927, vol. XI, pt. I, pp. 866-1283, passim.

² Platt, H., and Bristow, W. R.: The End Results of Operations for Injuries of the Peripheral Nerves. *Brit. J. Surg.* 11: 535-567, January 1924.

³ Benisty, A.: Treatment and Repair of Nerve Lesions, edited by E. F. Buzzard. London: University of London Press, Ltd., 1918.

⁴ Tinel, J.: Nerve Wounds. Symptomatology of Peripheral Nerve Lesions Caused by War Wounds. Philadelphia: W. B. Saunders Co., 1922.

⁵ Stookey, Byron: Surgical and Mechanical Treatment of Peripheral Nerves. Philadelphia: W. B. Saunders Co., 1922.

⁶ Pollock, Lewis J., and Davis, Loyal: Peripheral Nerve Injuries. New York: Paul B. Hoeber, Inc., 1933.

peripheral nerve injuries could have assumed these responsibilities more readily. They could also have passed more readily to the more difficult problems of nerve injuries associated with soft tissue, bone, and vascular injury; traction palsy; the therapy of causalgia; and the perplexing management of neuromas in continuity.

Policies of Nerve Repair

Theoretically, the advantages of prompt suture in peripheral nerve injuries had been fully recognized in World War I. Practically, because most of these wounds were actually infected or there was good reason for believing that they would become infected, a policy of rather extreme conservatism had to be adopted. The majority of patients with peripheral nerve injuries were treated in specialized centers in the Zone of Interior, and definitive surgery was not, as a rule, performed until several months after the injuries had been sustained, as will be pointed out shortly. An additional reason for the postponement of definitive surgery was delay in evacuation, which naturally was very much slower in World War I than in World War II. The inevitably poor results of nerve suture under these circumstances were reflected in numerous statements that battle casualties with this type of injury were doomed, at best, to a mediocre functional result. This feeling, which was essentially accurate for the period, persisted well into the early years of World War II and was with difficulty replaced by a more optimistic point of view.

Generally speaking, no important technical advances were made in the surgery of peripheral nerve injuries in World War II with the possible exception of the introduction of tantalum wire sutures and tantalum cuffs. The striking improvement in results rested more upon a fuller appreciation of the principles of nerve repair than upon mechanical or surgical advances in technique.

Forward surgery.—During World War I, conditions in forward areas and the pressure of work made it impossible to do more than emphasize the necessity of some sort of neurologic examination of every patient with a wound of the extremities before any major debridement was undertaken. When this precaution was omitted, excision of presumably contaminated tissue in the depth of the wound not infrequently led to accidental division of regional nerves.

If the neurologic examination produced evidence of nerve damage, it was urged that the nerve be exposed in the wound; that a record be made of the findings; and that, if the nerve were severed, it be sutured immediately. It was believed that this policy offered the best chances of restoration of function, but it could be employed only in isolated cases, in view of the regulation forbidding primary wound closure during the active fighting in the summer and fall of 1918.

Neurosurgical Centers

It was recognized in World War I that peripheral nerve injuries, by reason of their complexity, demand the cooperation of the neurologist, the "surgeon skilled in neurologic surgery," the orthopedic surgeon, and the personnel of a well-developed physical therapy department. For this reason, special centers were set up to which casualties with peripheral nerve injuries were to be sent. In all, 12 such centers were set up, though the majority of patients were concentrated in 6.

Peripheral Nerve Registry

On 29 January 1919, in recognition of the complexities of peripheral nerve injuries, The Surgeon General appointed a Peripheral Nerve Commission to correlate and study these injuries, which accounted for the majority of neurosurgical casualties returned from overseas. In the confusion of their return, many of these patients had been unavoidably scattered through general and base hospitals, and one of the first duties of the Peripheral Nerve Commission was to see to it that they reached the specialized centers. On the advice of the commission, the Section of Brain Surgery, Surgeon General's Office, printed and distributed blanks for a Peripheral Nerve Registry. Every patient with a peripheral nerve injury was examined and studied according to this form, and duplicate copies were furnished to the Section on Brain Surgery for the use of the commission as the patients were discharged. Commanding officers of all hospitals were instructed to recommend the transfer to specialized centers of all patients who were hospitalized in nonspecialized hospitals.⁷

The 3,129 peripheral nerve registers which were filed in the Surgeon General's Office represent between 80 and 90 percent of all the peripheral nerve injuries for which surgery was done in U.S. Army hospitals in World War I. It was hoped that the organization, which seemed ideal for the purpose, could be maintained, so that a thousand or more neurorrhaphies could be studied from the standpoint of long-term results. Unfortunately, this hope was not realized.

Arrangements were not made for followup studies while the patients were hospitalized. During 1919, the supervision of all patients who did not require operative treatment was transferred to the U.S. Public Health Service, under the Bureau of War Risk Insurance, and in 1921, the Veterans' Bureau took over the care of the remaining patients who were then under treatment or who were compensable.

The more than 3,000 operations recorded in the Peripheral Nerve Registry had been performed chiefly by skilled neurosurgeons, under almost ideal conditions, with trained neurosurgical assistance and with supplemental physical therapy available. It is most unfortunate that these patients

⁷ Circular Letter No. 100, Surgeon General's Office, U.S. Army, 21 Feb. 1919.

could not be followed up, but dealing with three widely scattered governmental agencies proved an impossible task. The majority of followup examinations which were made were carried out by inexperienced personnel and were correspondingly unreliable.

Timelag and End Results

It was the general practice at neurosurgical centers in World War I to postpone operations for a minimum of 3 months after wound healing. Since the majority of wounds were infected, the timelag was more nearly 4 to 8 months and sometimes even longer. A number of operations were performed after August 1919, in patients who for one reason or another, chiefly overcrowding, had not passed through the neurosurgical centers. They were discovered when they appeared for adjustment of compensation. At General Hospital No. 11, 31.5 percent of 400 patients were operated on by the end of the fourth month, 41 percent by the end of the fifth or the sixth month, and 15.5 percent by the end of the eighth month.

Only a few end results of peripheral nerve surgery were recorded in the official history of the Medical Department in World War I.⁸ In 496 operations, consisting of 350 neurorrhaphies, 132 neurolyses, and 14 transplants, the best results were secured in surgery on the internal popliteal and median nerves, in which there were, respectively, 92 percent and 86 percent of mediocre and good results. The highest percentage of failure, oddly, occurred in operations on the musculospiral nerve, almost half of which were unsuccessful. The results in the ulnar and sciatic nerves were about midway between these extremes, there being 70 percent good or mediocre results.

The generally poor results of neurolysis could be explained by the fact that the military neurosurgeons of World War I had an insufficient knowledge of neuropathology.

⁸ See footnote 1, p. 207.

CHAPTER X

The Zone of Interior

Barnes Woodhall, M.D.

EARLY NERVE REPAIR

Principles and Rationale

The most important advance to come out of World War II in the management of peripheral nerve injuries in the Zone of Interior was, as elsewhere, the general application of the principle of early nerve repair. Even before the entry of the United States into the war, experimental and histopathologic evidence had indicated that the optimum time for end-to-end suture of severed nerves is between the third and the sixth week after injury. Clinicians were slow to test these concepts on battle casualties, but eventually the policy of extreme conservatism, which implies delay, was abandoned and was replaced by a policy of prompt exploration, within a period of 21 to 90 days after wounding, of all nerve injuries in which there was the least doubt that spontaneous regeneration was occurring.

This alteration in surgical principles and practice was based upon a number of considerations, including (1) statistical evidence of a high incidence of nerve division in the early experience of the Mediterranean and then the European theater, (2) absence of primary wound infection as the result of the new plan of management of soft-tissue wounds, (3) pathologic demonstration of what constitutes a neuroma in continuity, (4) the ease and safety of nerve exploration in competent hands under local analgesia, and (5) evidence that damaged nerves are likely to regenerate rapidly when they are treated before degenerative changes occur in the distal nerve trunk. Evidence substantiating the validity of early nerve repair continued to accumulate as studies of regenerating nerve injuries were recorded in the Peripheral Nerve Registry (p. 225).

Combined Injuries

A second major advance in the treatment of peripheral nerve injuries in World War II resulted from a deeper appreciation of the influence of soft-tissue, bone, and vascular injuries upon the timing of nerve repair and the technical methods by which it was achieved. These injuries were frequent and serious, and it is surprising that so little attention was originally paid to the possibility of improvement of results by their combined management.

In vascular injuries associated with nerve injuries, the factor of neural ischemia, with its well-established pathologic sequelae, had to be considered in relation to the usual crippling effect of the peripheral nerve injury alone. The organization of three vascular centers in Zone of Interior general hospitals (Ashford General Hospital, White Sulphur Springs, W. Va., Mayo General Hospital, Galesburg, Ill., and DeWitt General Hospital, Auburn, Calif.) was a partial solution of a problem which was never, unfortunately, fully solved. The dramatic, lifesaving character of the therapy directed toward the vascular component of the injury tended to submerge the real significance of the less acute, but often more disabling, nerve injury. The neuropathologic changes which occur in ischemia were well understood, but this understanding, regrettably, was not translated, in any of the neurovascular centers, into a coordinated clinical study of these injuries. A real opportunity was thus missed.

Combined bone and nerve injuries tended to progress satisfactorily and rapidly when the professional talents of orthopedic surgeons and neurosurgeons were available on a combined ward. Coordination of effort along these lines in Zone of Interior hospitals soon proved, beyond a doubt, that nerve repair can be hastened and new approaches to joint problems discovered if a damaged limb is treated as a single structure rather than in terms of its various isolated component parts. Progress in the coordinated attack, it must be granted, was not as rapid as it should have been. It was sometimes confused, for example, by peering too closely at the femur and thus losing sight of the gradual deterioration of muscle, nerve, and skin which was occurring as the progressive result of nerve injury. Improvement was eventually achieved by the enthusiastic pioneering of young orthopedic surgeons and neurosurgeons who worked as teams, as well as by constant emphasis upon the high priority of peripheral nerve injuries in neurosurgical centers.

DIAGNOSTIC PROCEDURES

When the neurosurgeon deals with only a limited number of patients, as he does in civilian practice, it is a relatively easy matter to carry out deliberate and careful examinations and record the results. When, however, the military neurosurgeon is confronted with the mass of peripheral nerve injuries which are encountered in wartime and which must be treated under military conditions, a very different situation exists. That is why there was a steadily increasing tendency toward centralization of diagnostic methods in so-called nerve laboratories in the Zone of Interior neurosurgical centers in World War II (figs. 89 and 90).

An adequate heritage of knowledge concerning accepted methods of diagnosis of peripheral nerve injuries was available at the start of World War II. Sensory patterns and supplementary motor movements had been thoroughly studied and were generally understood. The significance of Tinel's

sign was fully appreciated. The techniques of simple manual examinations were generally known, and possible errors and pitfalls based upon anatomic variations were clearly recognized.

Not as much can be said for the more objective methods of neurologic investigation. The reaction of injured peripheral nerve tissue to galvanic and faradic stimulation was known, but this method cannot be considered refined, and it was obviously not applicable to large numbers of casualties. Moreover, testing had been officially made the responsibility of the physical therapy departments in general hospitals, and examinations, as a result, suffered from lack of standardization, as well as from the fundamental defects inherent in a secondhand report of a study carried out by personnel not responsible for the therapy to be based upon the results of the examination.

Other methods for recording electrical activity were still in the laboratory stage of development at the beginning of the U.S. participation in World War II if they existed at all. These methods are all useful in identifying partial nerve lesions, detecting early regeneration, and permitting quantitative estimations of recovery, and there was great need for them.

The war years were to see a steady (though individualistic and uncoordinated) effort in Zone of Interior hospitals to achieve progress in this important field. Results were limited during the war, but they promised to come to more complete fruition in the postwar era.¹

One particularly important diagnostic effort was the determination of the galvanic-tetanus ratio, which was developed and refined by Pollock and his group,² under a National Research Council contract, and which was studied intensively at the neurosurgical center at the Percy Jones General Hospital, Battle Creek, Mich.

Another important advance was the observation by Richter³ that, under certain conditions, the area of increased skin resistance after section of a peripheral nerve approximates the area of sensory loss. This observation led to the development of a rapid and objective method for delineating sensory patterns (fig. 91). A large number of studies by this method upon

¹ The report of electrodiagnostic techniques and results in the followup study of 3,656 World War II peripheral nerve injuries, edited by Barnes Woodhall, M.D., and Gilbert W. Beebe, Ph. D., and published in 1957, shows that this prophecy has been amply fulfilled.

² (1) Pollock, L. J., Golseth, J. G., and Arieff, A. J.: The Use of Discontinuity of Strength Duration Curves in Muscle in Diagnosis of Peripheral Nerve Lesions. *Surg. Gynec. & Obst.* 79: 133-141, August 1944. (2) Pollock, L. J., Golseth, J. G., and Arieff, A. J.: Use of Galvanic Tetanus and the Galvanic Tetanus Ratio in Electrodiagnosis. *Arch. Neurol. & Psychiat.* 54: 317, October 1945. (3) Pollock, L. J., Golseth, J. G., Arieff, A. J., and Mayfield, F.: Electrodiagnosis by Means of Progressive Currents of Long Duration; Studies on Peripheral Nerve Injuries in Man. *Surg. Gynec. & Obst.* 81: 192-200, August 1945. (4) Pollock, L. J., Golseth, J. G., Mayfield, F., Arieff, A. J., Liebert, E., and Oester, Y. T.: Spontaneous Regeneration of Severed Nerves. *J.A.M.A.* 134: 330-333, 24 May 1947.

³ (1) Richter, C. P.: Sympathetic Innervation of the Skin: Experimental and Clinical Studies. *Arch. Neurol. & Psychiat.* 48: 1028-1030, December 1942. (2) Richter, C. P., and Malone, P. D.: Peripheral Nerve Lesion Charts. *J. Neurosurg.* 2: 550-552, November 1945. (3) Richter, C. P., and Woodruff, B. G.: Lumbar Sympathetic Dermatomes in Man Determined by the Electrical Skin Resistance Method. *J. Neurophysiol.* 8: 323-338, 1 Sept. 1945.

Form 55 E-10A
 MEDICAL DEPARTMENT, U. S. A.
 (Authorized April 27, 1943) **PERIPHERAL NERVE EXAMINATION**

Date 26 June 1945

Name _____ Grade Pvt. Serial No. _____

Organization Unsgd. Inf. Date of injury 17 July 1944

Describe injury: Wound perforating moderate, middle 1/3 of upper arm, caused by shell fragment. (Right)
 Debridement 7 hours
 Secondary closure 15 August

Condition of wound:
 Wound healed 30 August 1944

Date of operation: 26 December 1944

Type of operation: Neurorrhaphy, radial nerve, right. Silk.

Name of surgeon: Lt. E. E. Clifton, W.G.H.

Improvement since injury: No evidence of return of function radial nerve. 10 Dec. (Subjective and objective) There has been no return of function since operation. 26 January 1945.
 Definite return of function of the brachio-radialis and Supinator and beginning function of the extensor carpi radialis. 30 May 1945.
 Definite return of function of muscles of Radial nerve since operation. 26 June 1945.

Summary: WIA 17 July 1944 perforating moderate, middle 1/3 of upper arm, caused by shell fragment. (Right) Debridement 7 hrs. Secondary closure 15 Aug. Wound healed 30 August 1944. Neurorrhaphy 26 Dec. 1944, radial nerve. There has been definite return of function of the brachio-radialis and Supinator and beginning function of the extensor carpi radialis. 30 May 1945. There has been further return of function with definite contraction of Extensors of the wrist. There is beginning return of sensation. 26 June.

Eugene E. Clifton
 EUGENE E. CLIFTON, Lt. M. C.

10-24851-1

FIGURE 90.—Form used for examination of peripheral nerves (page 1).

IMPORTANT MUSCLES READILY ACCESSIBLE TO EXAMINATION

- 26 Jan. 1945
- UPPER EXTREMITY
- 3 RADIAL (C. C. C. G. T.)
 - 0 TRICEPS
 - 0 BRACHIO RADIALIS
 - 0 EXTENSOR CARPI LONGUS
 - 0 SUPINATOR
 - 0 EXTENSOR COMMUNIS DIGITORUM
 - 0 EXTENSOR CARPI ULNARIS
 - 0 ABDUCTOR POLLICIS LONGUS
 - 0 EXTENSOR POLLICIS LONGUS
 - 0 EXTENSOR POLLICIS BREVIS
 - 0 MEDIAN (C. C. C. G. T.)
 - 0 PRONATOR TERES
 - 0 FLEXOR CARPI RADIALIS
 - 0 FLEXOR DIGITORUM SUBLIMIS
 - 0 FLEXOR LONGUS POLLICIS
 - 0 ABDUCTOR POLLICIS BREVIS
 - 0 OPONENS DIGITI V
 - 0 FLEXOR CARPI ULNARIS
 - 0 PROFUNDUS
 - 0 ULNAR (C. T.)
 - 0 FLEXOR CARPI ULNARIS
 - 0 ABDUCTOR DIGITI V
 - 0 DORSAL AND PALMER INTEROSSEI
 - 0 ADDUCTOR POLLICIS
- SPINAL ACCESSORY
- 0 STERNOCLEIDOMASTOID
 - 0 TRAPEZIUS
 - 0 DORSALIS SCAPULAE
 - 0 RHOMBOID
 - 0 LONG THORACIC (C. C. C.)
 - 0 SERRATUS ANTERIOR
 - 0 THORACO DORSALIS (C. C. C.)
 - 0 LATISSIMUS DORSI
 - 0 PECTORAL NERVES (C. C. C.)
 - 0 PECTORALIS MAIOR
 - 0 SUPRA SCAPULAR (C. C.)
 - 0 SUPRASPINATUS
 - 0 INFRA SPINATUS
 - 0 MUSCULO CUTANEUS (C. C.)
 - 0 BICEPS BRACHII
 - 0 AXILLARY (C. C.)
 - 0 DELTOID

LOWER EXTREMITY

- 0 FEMORAL NERVE (L. L. L.)
- 0 ILIOSACS
- 0 QUADRICEPS FEMORIS
- 0 ADDUCTORS
- 0 SCIATIC (L. L. S. S. S.)
- 0 GLUTEUS MAXIMUS
- 0 BICEPS FEMORIS
- 0 SEMITENDINOSUS
- 0 POSTERIOR TIBIAL
- 0 GASTROCNEMIUS
- 0 TIBIALIS POSTICUS
- 0 FLEXOR DIGITORUM LONGUS
- 0 FLEXOR DIGITORUM HALLUCIS
- 0 COMMON PERONEAL
- 0 TIBIALIS ANTIUS
- 0 EXTENSOR LONGUS DIGITORUM
- 0 EXTENSOR LONGUS TIBIALIS
- 0 PERONEUS LONGUS AND BREVIS

CODE

- 0=No demonstrable function.
- 1=Barely perceptible function.
- 2=50 percent function.
- 3=75 percent function.
- 4=100 percent function.

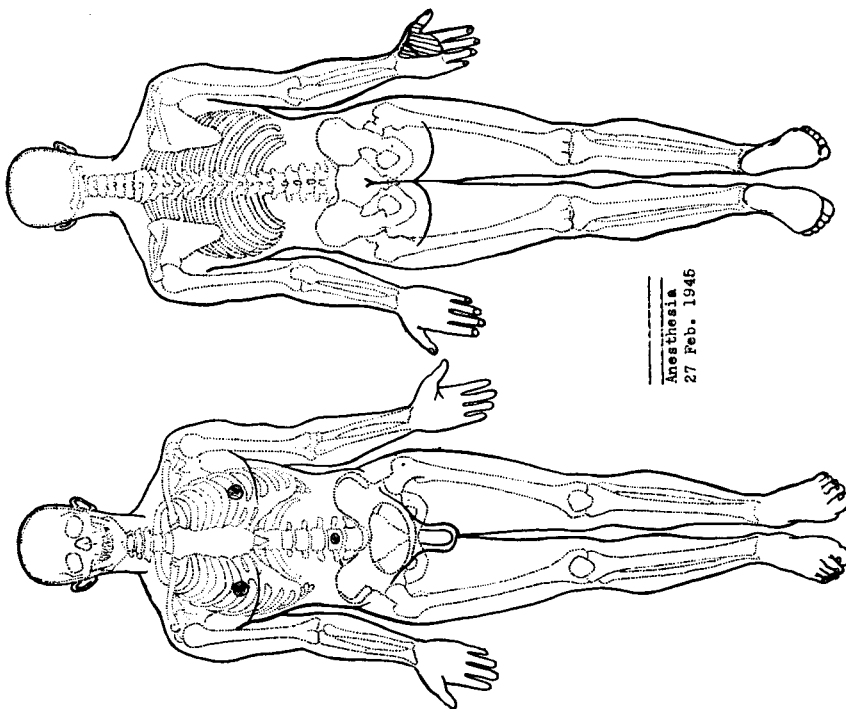

PERIPHERAL NERVE EXAMINATION

FIGURE 90.—Continued. Pages 2 and 3 of form.

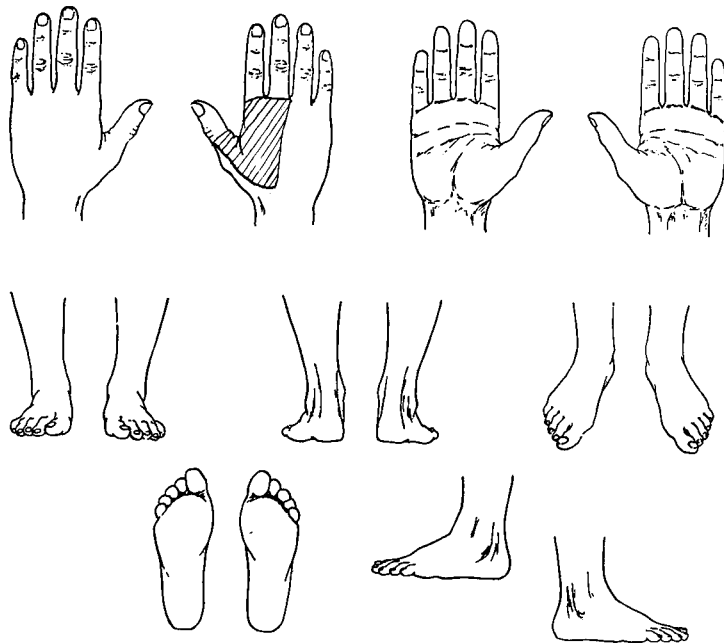

FIGURE 90.—Continued. Page 4 of form.

individual nerve divisions and the subsequent course of their regeneration were carried out at the neurosurgical centers at Walter Reed General Hospital, Washington, D.C., Newton D. Baker General Hospital, Martinsburg, W. Va., and Halloran General Hospital, Staten Island, N.Y.

In the closing months of World War II, instruments for the determination of skin resistance were distributed to all neurosurgical centers, with complete instructions for their use.⁴ At the same time, personnel from each center were trained in the technique of electrodiagnosis at the neurosurgical center at Percy Jones General Hospital.

The ideal of a simple, readily applicable battery of instruments for objective nerve testing was an objective all through the war, but it had not been completely achieved when hostilities ended. Hope that this effort would continue in the postwar era was fostered by the ready acceptance by the Army of a National Research Council project in this field, to be correlated with the study of large numbers of regenerating nerve lesions in patients under treatment in the hospitals of the Veterans' Administration.⁵

⁴ Richter, C. P.: Instructions for Using the Cutaneous Resistance Recorder or "Dermometer," on Peripheral Nerve Injuries, Sympathectomies, and Paravertebral Blocks. *J. Neurosurg.* 3: 181-191, May 1946.

⁵ Woodhall, B., and Beebe, G. W. (editors): *Peripheral Nerve Regeneration. A Followup Study of 3,656 World War II Injuries.* Washington: U.S. Government Printing Office, 1957.

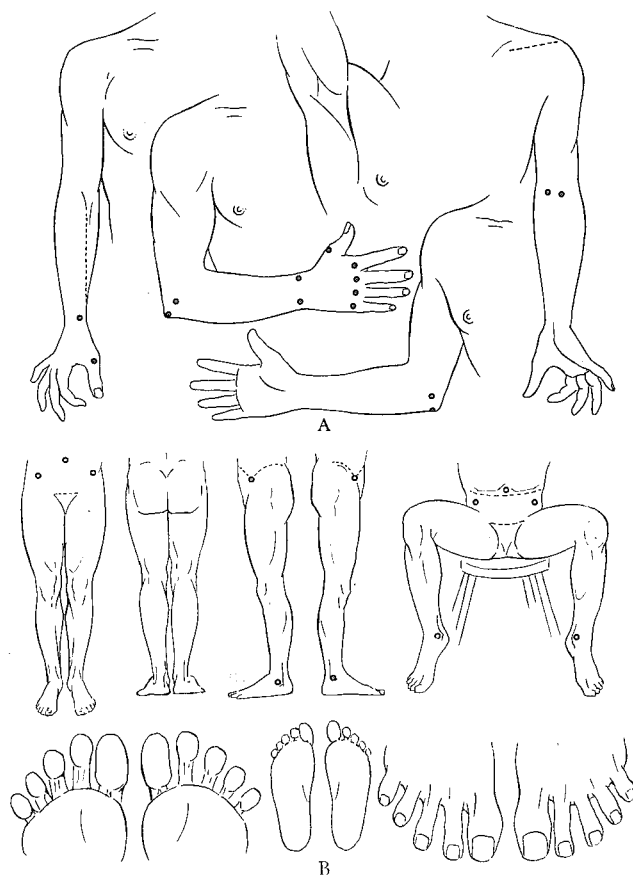

FIGURE 91.—Charts used in mapping areas of anesthesia or high electrical skin resistance produced by peripheral nerve and other neurologic lesions (modified from Richter and Malone). A. Upper extremity. B. Lower extremity.

NERVE GRAFTING

In the interim between World War I and World War II, nerve grafting had occasionally been carried out, but the only new and hopeful study had been an experimental investigation of frozen dried homografts. Early in World War II, plans were formulated for the development of a neurosurgical center at Walter Reed General Hospital, to which patients with presumably irreparable nerve injuries should be referred for nerve grafting. The experience at Cushing General Hospital, Framingham, Mass., to which the program was transferred in 1944, is related elsewhere in this volume (p. 493). At Walter Reed General Hospital,⁶ failure followed all eight homo-

⁶ Spurling, R. G., Lyons, W. R., Whitcomb, B. B., and Woodhall, B.: The Failure of Whole Fresh Homogenous Nerve Grafts in Man. *J. Neurosurg.* 2: 79-101, March 1945.

grafts. In the seven cases in which the grafts were later removed, the injury was successfully repaired by end-to-end suture, supplemented by the methods of mobilization and transplantation which became standardized as the war progressed. Among 26 nerve injuries referred to this center as irreparable, only 6 could not be repaired by the use of these techniques.⁷

Even at the end of the war, nerve grafting in man was still, for all practical purposes, in the experimental stage. In no other field of peripheral nerve surgery had such auspicious results in the laboratory been followed by such dismal failures in clinical application. With the exception of the successful autografting of small nerves, such as the facial and digital nerves, and an occasional impressive instance of regeneration in frozen dried homografts (p. 500), the record of nerve grafting in man was a practically unbroken record of failures in World War II, as it had been in World War I.

MANAGEMENT OF CAUSALGIA

The syndrome of causalgia had been known since the Civil War, but the successful therapy of this distressing condition dates from 1930, when the first dorsal sympathectomy for causalgia of the upper extremity was performed by Spurling.⁸ The events of World War II proved that the relief of causalgic pain secondary to combat-incurred peripheral nerve injuries can be achieved by an appropriate attack upon the sympathetic nervous system (p. 488).

NEUROPATHOLOGIC STUDIES

Very little knowledge concerning the intrinsic pathologic changes which occur in peripheral nerve injuries was inherited from the experience of World War I. A great deal of pertinent information was contained in the protocols of Huber's animal experiments,⁹ it is true, but it was not translated to human experience. The practical problem, therefore, which faced neurosurgeons in neurosurgical centers in Zone of Interior hospitals in World War II was the correlation of pathologic changes in damaged nerve segments with the extent of neural resection required before nerve suture could be undertaken. There was also need for information concerning the effects of traction and ischemia, as well as concerning changes characteristic of lesions in continuity.

⁷ Followup studies of peripheral nerve injuries by the Followup Agency of the National Research Council developed by the Committee on Veterans Medical Problems in cooperation with the Veterans' Administration, the Army, and the Navy, include 42 cases in which nerve grafting was performed. In 12 instances, no secondary surgery was performed. In 10 instances, secondary surgery was limited to exploration and lysis. In the remaining 20 cases, end-to-end anastomosis proved practical.

⁸ Spurling, R. G.: Causalgia of the Upper Extremity; Treatment by Dorsal Sympathetic Ganglionectomy. *Arch. Neurol. & Psychiat.* 23: 784-788, April 1930.

⁹ Huber, G. Carl: Experimental Observations on Peripheral Nerve Repair. *In* The Medical Department of the United States Army in the World War. Washington: Government Printing Office, 1927, vol. XI, pt. 1, pp. 1091-1283.

Pathologic laboratories in Army general hospitals were too fully occupied with routine tasks to undertake special studies. The considerable mass of gross material which was produced by an average of 6 neurosurgical procedures daily at each of 19 or 20 neurosurgical centers could not possibly be processed by available laboratory personnel in terms of frozen sections, permanent sections, and photographic records. In addition, these laboratories were not staffed or equipped for such highly specialized investigations.

The practical result of this combination of a deficit in fundamental knowledge and a shortage of facilities and qualified personnel was reflected early in World War II in a more or less total disregard by neurosurgeons of intrinsic neural changes in damaged peripheral nerves, as well as by a lack of comprehension of their significance. The statement can be made, without qualification, that most neurosurgeons early in the war did not know what they were suturing and whether the tissues they were uniting were normal or damaged. In some centers, as a matter of fact, this fundamental aspect of peripheral nerve surgery was not fully appreciated until the end of the war. Operative notes mentioned "fibrous," "atrophic," or "normal appearing" nerve ends, but correlation of clinical observations with adequately stained tissue specimens was for the most part missing.

In many neurosurgical centers, on the other hand, consistent efforts were made as the war progressed to study the pathologic changes in nerve segments by one of two methods of approach. One was the use of frozen sections. The other was the more refined method of constant comparison of gross findings with stained tissue slides. The potential as well as immediate value of permanent sections for comparative study during the course of neural regeneration soon became evident. It also became equally evident that only a trained histopathologist, devoting his entire time to the task and furnished with special equipment, could possibly study the mass of material available for investigation and thus increase the factual knowledge which must underlie any clinical advance.

Tables of organization for general hospitals did not provide for a histopathologist with special training in neuroanatomy, and it was only by a series of fortunate, entirely fortuitous circumstances that the services of Dr. William R. Lyons, Associate Professor (now Professor) of Anatomy, University of California Medical School, Berkeley, Calif., could be obtained for this purpose. In the spring of 1944, Dr. Lyons was commissioned captain in the Sanitary Corps, U.S. Army. He had been admirably fitted by his previous experience in high-altitude studies with the National Research Council for his immediate mission, the application of the rapid freezing-dehydration technique for the production and study of human nerve grafts. His larger mission was the study of peripheral nerve injuries, particularly the neuropathologic changes associated with them.

During the slow process of collecting the necessary equipment for the nerve-graft studies, Captain Lyons began the study of correlating neuro-

pathologic changes in damaged nerves with the progress of neural regeneration. The natural evolution of interest in this problem, as well as in nerve grafting, inevitably led to the appearance of the neuroanatomist at the side of the neurosurgeon in the operating room, to gather anatomic material and to teach the neurosurgeon the facts of neuropathology. Data concerning the history of the injury, the operative findings, and the gross and histologic changes were assembled and were recorded by photography and photomicrography. Correlation of these observations with the progress of neural regeneration was achieved through the Peripheral Nerve Registry (p. 225). Eventually, a neuropathologic laboratory which approached the ideal in organization was established at the Halloran General Hospital.

Early in the evolution of Captain Lyons' work, an accession number was provided for his material, and the full facilities of the Army Medical Museum were placed at his disposal by the director of the Army Institute of Pathology. These facilities continued to be at his disposal even after the transfer of his laboratory from its original location in Walter Reed General Hospital to Halloran General Hospital. The clinical, pathologic, and photographic source material derived from the nerve injuries studied by Captain Lyons was later deposited in the Army Institute of Pathology (now the Armed Forces Institute of Pathology) and was available for additional and more detailed histologic study and for correlation with studies of clinical neural regeneration as it progressed in the patients followed up after the war.

DISPOSITION

Evolution of Policies

It was recognized early in World War II that because convalescence from peripheral nerve injuries is often prolonged, the efficient use of the bed capacity of the general hospital system could quickly become impaired if the hospitalization of these casualties were continued beyond the point of definitive treatment. On the other hand, it was necessary to continue to observe these patients beyond this time period. It was also desirable to secure as much technical information as possible about these injuries during the period of neural regeneration, when no active therapy was being carried out.

All of these considerations were reflected in the first directive issued concerning the disposition of patients with peripheral nerve injuries. War Department Circular No. 224, section IV, 21 September 1943, read as follows:

* * * Military personnel who have sustained injuries to the peripheral nerves will not be discharged from the Army until the maximum degree of recovery has been achieved. If otherwise qualified, such patients should be placed on a duty status which permits them to perform work in accordance with their capabilities and be reexamined at least every 3 months at the hospital where they were last treated for the nerve injury until maximum recovery has been achieved and final disposition can be made.

Within a year after this directive had been issued, two very undesirable situations had developed, as follows:

1. Although directives had been issued previously to the effect that patients with peripheral nerve injuries should be treated in neurosurgical centers in designated general hospitals, there still remained outside of these centers a rather large number of patients whose nerve injuries had been associated with bone or vascular injuries or both. Although these casualties were given high priorities, at embarkation points, there had been a tendency to concentrate on the vascular injury or the bone injury (p. 211) and a failure to consider the injured extremity as a whole. Combined centers or wards for the treatment of combined injuries had improved the situation but had not solved the entire problem. Since the nerve injury was usually basically responsible for the functional defect, it would have been wiser, without delay, to have made the combined injury the responsibility of the neurosurgeon.

2. War Department Circular No. 224 had apparently not been sufficiently explicit concerning the return of patients with peripheral nerve injuries to neurosurgical centers after 3 months of restricted duty status. As a result, a considerable number of patients were being lost to observation.

War Department Circular No. 423, section II, 27 October 1944, made mandatory the treatment of all patients with peripheral nerve injuries by a neurosurgeon in a neurosurgical center. It also provided that—

* * * Military personnel who have sustained injuries to peripheral nerves will not, if otherwise qualified, be discharged from the Army until maximum degree of recovery has been achieved. Such patients will be placed on duty status which permits them to perform work in accordance with their capabilities, and will be reexamined every 3 months until maximum recovery has been achieved and final disposition can be made. In order to make sure that such patients actually appear for reexamination, they should, at the time of disposition from hospital where they have received definitive treatment, be ordered to return at the end of 3 months for reexamination at the nearest general hospital specializing in neurosurgery. If, upon such reexamination, it is determined that maximum recovery has not been achieved, they will again be ordered to present themselves at the end of another 3-month period for reexamination at the nearest general hospital specializing in neurosurgery. This will be continued until maximum recovery has been achieved.

This circular was later amended to provide that patients with peripheral nerve injuries which required further surgical treatment should be returned to the center in which definitive treatment had been initiated.

Final Disposition

The final disposition of patients with peripheral nerve injuries was originally dependent in large part upon the need and demand for restricted duty personnel. Few men who had suffered major nerve injuries could be returned to full duty commensurate with the requirements of combat. During the year after the issuance of War Department Circular No. 423, on 27 October 1944, a large pool of men with peripheral nerve injuries was accu-

mulated on a restricted duty status. They were of little value, since most Army installations already possessed a sufficient number of restricted duty personnel, and there were persistent demands from unit commanders to be protected against the assignment of unusable personnel.

It was next thought that the disposition of these patients to the convalescent hospital system might provide a solution to the problem, but this plan proved unsatisfactory from every standpoint. About the only justification for it was the enormous pressure for beds then being put upon the neurosurgical centers. At one time, casualties with injuries of the peripheral nerves were sent directly to convalescent hospitals from debarkation points, before their injuries had been evaluated. Their care was, of course, inadequate, convalescent hospitals being totally unsuited for neurosurgical care and observation. Moreover, since disposition of these patients was a function of the convalescent hospital, all semblance of continuity of neurosurgical treatment was lost, and registration of these injuries in the Peripheral Nerve Registry was also ineffective.

Ninety-day work furlough.—The lack of demand for restricted duty personnel in the Army and failure of disposition of patients to the convalescent hospital system to solve the problem of these casualties led to the introduction of the 90-day work-furlough plan. This plan, initiated at Cushing General Hospital, was, as its name implied, a work furlough, during which patients occupied themselves with useful civilian pursuits. The 90-day period was sufficiently long for demonstrable changes in neuroregeneration to occur and was also sufficiently long for the patient to perform some useful labor and thus contribute to the solution of the manpower crisis then plaguing the country.

A patient with a peripheral nerve injury was regarded as eligible for work under the following conditions: (1) If he did not require further active or passive physiotherapy, (2) if he was able to use, in good measure, some part of the injured extremity, (3) if there was indisputable evidence of neuroregeneration, of either spontaneous or surgical origin, and (4) if the patient was cognizant of possible injury to anesthetic areas and was able to walk, for instance, for a reasonable distance without injury to such an area.

These criteria were applied in both postoperative cases and in cases in which surgery was not required or was not planned within a month of the beginning of the furlough.

A great deal of attention was paid to evaluation of the patient's temperament and of his attitude toward the prospective work before the furlough was granted. Psychoneurotics, neurasthenics, alcoholics, and other emotionally unstable persons were promptly found to be unsuitable for this kind of disposition. Their work record was irregular, they were sick the greater part of the time, and they were a constant source of dissatisfaction and actual irritation to their employers and in the organizations in which they worked.

The process of granting the furlough after preliminary arrangements had been made between the employer and the prospective employee was carefully detailed. When the patient returned from the work furlough for reexamination, every effort was made to expedite the general examination and the evaluation of his neurologic status. If maximum hospitalization benefits had not yet been achieved, he could often be returned to work on the day of the examination. If, however, he was regarded as ready for some type of final disposition, then he was admitted to the hospital, and disposition was carried out through the usual channels.

Postwar Disposition

With the ending of the war in Europe, the relation between the Medical Corps officer and the neurosurgical patient assumed more and more of the usual doctor-patient relation, quite uninfluenced by the pressure of emptying hospital beds or of returning soldiers to duty in a fighting army. Under the new circumstances, the previous definition of maximum hospital benefits could no longer be considered realistic, since there was no longer any necessity to return men to limited service duty. The patients themselves were eager to get back to their homes. The Army hospital system was in process of reduction. Veterans' hospitals were in process of expansion.

To cover disposition to convalescent furloughs and to redefine the criteria of maximal hospital benefits in peripheral nerve injuries, Army Service Forces Circular No. 244 was issued 28 June 1945. In it the following clinical criteria were outlined as guides for neurosurgeons in the management of patients with these injuries:

- * * * * *
2. Eligibility of peripheral nerve injury cases for convalescent furlough or sick leave, detached service, and transfer to convalescent hospitals is dependent upon the neurosurgeon's evaluation of the progress of regeneration, the necessity for supervised physiotherapy, and the patient's ability to care for himself without harm to his regenerating nerve or jeopardy to his denervated extremity. The following points will be considered:
 - a. General condition of the extremity.
 - b. Requirement for further operation.
 - c. Necessity for physiotherapy other than that self-administered.
 - d. Favorable expectancy of nerve regeneration as evidenced by an intact suture line, examined by X-ray when metallic sutures are used, descent in Tinel's sign, decrease in muscle atrophy, alteration towards normal in electro-diagnostic tests, decrease in skin resistance patterns, and the like.
 - e. Extent of the patient's insight into the potential hazards of his disability.
 3. Maximal benefit of hospitalization is based on the following:
 - a. Those cases which have undergone operative repair or spontaneous resolution must possess as a minimum, regeneration of the injured nerve to the point of innervation of proximal musculature and to a steady diminution in the sensory loss of the involved autonomous zone. In more distally placed injuries regeneration of the nerve to the sensory status described may be considered minimal evidence of regeneration.
 - b. No remediable deformity secondary to nerve injury should exist which can be controlled or functionally corrected by physiotherapy and orthopedic or plastic rehabili-

tation measures with the exception of distal deformities, such as opponens or extensor hallucis longus paralyse which may require prolonged observation prior to reconstructive surgery.

c. Irreparable nerve injuries must have been considered for orthopedic and plastic rehabilitation measures and such measures completed or rejected.

d. In cases where other conditions are associated with peripheral nerve injuries, the above criteria are the minimum to be met prior to disposition.

PERIPHERAL NERVE REGISTRY

For all practical purposes, as indicated elsewhere (p. 207), the knowledge relating to the biologic and technical factors of nerve repair and regeneration which might have stemmed from the experience of World War I was almost completely lost. It was fortunately realized sufficiently early in World War II that the great mass of military neurosurgical data concerning peripheral nerve injuries would be similarly lost if an integrated effort were not promptly made to preserve them. The outcome of this effort was the formal establishment by The Surgeon General 22 November 1944 of the Peripheral Nerve Registry.¹⁰

Early records.—In March 1943 Maj. (later Col.) R. Glen Spurling, MC, then Consultant in Neurosurgery, Office of the Surgeon General, requested The Surgeon General to authorize a form to be used by all hospitals overseas and in the Zone of Interior for the uniform recording of peripheral nerve injuries. It was realized then that these injuries would be among the major surgical problems of the war, and at that time no special arrangements had been made to care for them. In October 1943, Major Spurling noted in his official diary that the problem was still unsolved.

After consultation with Maj. (later Lt. Col.) Barnes Woodhall, MC, on 1 March 1944, Colonel Spurling addressed a memorandum to Brig. Gen. Fred W. Rankin, Chief Surgical Consultant, Office of the Surgeon General, concerning the collection of neurosurgical data by means of central registries, similar in scope to the bone tumor registry and the Cushing brain tumor registry, which had proved so effective in civilian life.¹¹ The suggestion was made for two reasons: (1) That if new techniques of treatment were developed, accurate and reliable conclusions could be more readily drawn from accumulated material, and (2) that historical material would thus become available to be recorded after the war. As an example, it was suggested that all neurosurgical centers in the Zone of Interior should submit once a month to the chief of neurosurgery at Walter Reed General Hospital the identification and pertinent clinical data for all patients with peripheral nerve injuries treated during the month. Eventually, all followup observa-

¹⁰ Letter, Brig. Gen. Edward F. Witsell, Acting The Adjutant General, to commanding generals, all service commands and the Military District of Washington, 22 Nov. 1944, subject: Peripheral Nerve Injury Report (Control Approval Symbol MCR-118), SG Form 941.

¹¹ Letter, Lt. Col. R. G. Spurling, to Brig. Gen. Fred W. Rankin, Chief Surgical Consultant, Office of the Surgeon General, 1 Mar. 1944, subject: Collection of Clinical Data of Neurosurgical Interests Relative to War Casualties.

tions on all peripheral nerve injuries would find their way into this central registry.

In the discussion of this plan, it was pointed out that the introduction of tantalum as a suture and sheathing material was representative of the type of advanced methods which required evaluation by regimented studies. It was also pointed out that the data on the registry forms could be utilized as a cross section of the technical dexterity of participating neurosurgeons, many of whom were encountering for the first time the problems inherent in combat-incurred peripheral nerve injuries and their repairs.

Establishment of Registry.—The directive setting up the Peripheral Nerve Registry provided that forms be prepared for all patients with peripheral nerve injuries treated by nerve suture or nerve grafting, a separate form being prepared for each major nerve involved (fig. 92). The forms were to be sent to the Surgical Consultants Division, Office of the Surgeon General (1) immediately upon completion of the operative procedure; (2) as of the 90th, 180th, 270th, and 360th day of the patient's hospital stay, whether during the course of the first admission or any readmission; and (3) upon his final disposition from the hospital, whether on the first admission or a readmission.

On 18 April 1945, additional instructions were issued to aid in clarification of assessments of these individual injuries.¹²

Originally, it had been planned to register new cases of peripheral nerve injury only until 1 May 1945. In April 1945, the duration of the registry was extended to 31 December 1945. With the end of the Japanese phase of the war in August 1945, the necessity for an extension of such length disappeared, and on 12 September 1945, instructions were issued to end the registration of new cases as of 1 October 1945.¹³ Assessments of nerve injuries already registered were to be continued until the 360th day of hospitalization, or until earlier discharge, for all patients for whom an original Registry form had been submitted before this date.

At first, the Registry was maintained only in the general hospitals in the Zone of Interior designated for the care of neurosurgical casualties. Later, it was extended to oversea hospitals. The maintenance of the Registry was made the responsibility of the neurosurgical staffs of the participating hospitals, and approximately 85 neurosurgeons cooperated in the task.

Objectives of Registry.—The objectives of the Peripheral Nerve Registry were limited. It was restricted to a compilation of nerve sutures and nerve grafts. These operations were performed only in injuries which were complete and in which the study of regeneration would therefore be unqualified.

The Registry was designed for specialized studies going beyond the data required by Medical Department requirements. Its accuracy depended upon

¹² Letter, Maj. Gen. J. A. Ulio, The Adjutant General, to commanding generals, all service commands and the Military District of Washington, 18 Apr. 1945, subject: Peripheral Nerve Injury Report (Control Approval Symbol MCR-118) SG Form 941.

¹³ Letter, Maj. Gen. Edward F. Witsell, Acting The Adjutant General, to commanding generals, all service commands and the Military District of Washington, 12 Sept. 1945, subject: Peripheral Nerve Injury Report (Reports Control Symbol MCR-118) SG Form 941.

PERIPHERAL NERVE INJURY REPORT									
1. HOSPITAL		2. ADMISSION DATE		3. REGISTER NO.		COVERING APPROVAL			
4. NAME (Last, First, Middle Initial)		5. UNIT (Serial No.)		6. GRADE		7. DATE OF INJURY			
8. ORGANIZATION AND AID OR SERVICE		9. CAUSE AND LOCATION OF INJURY		10. INCLUDED NERVE (Check with area)		11. PATHOLOGIC SPECIMENS		12. OTHER (Specify)	
13. MEASUREMENT OF DEFECT		14. AFTER SURGERY		15. AFTER SURGERY		16. AFTER SURGERY		17. OTHER (Specify)	
18. END TO END ANASTOMOSIS OPERATIVE PROCEDURE		19. NERVE GRAFTING OPERATIVE PROCEDURE		20. DATE		21. DISPOSITION			
22. ASSESSMENT OF RECOVERY (See instructions)		23. DATE		24. DATE		25. DATE		26. DATE	
27. DATE EN.		28. SIGNATURE OF SUBSCRIBER		29. SIGNATURE OF NEUROLOGIST		30. SIGNATURE OF NEUROLOGIST		31. DATE	
13. MEASUREMENT OF DEFECT		14. AFTER SURGERY		15. AFTER SURGERY		16. AFTER SURGERY		17. OTHER (Specify)	
18. END TO END ANASTOMOSIS OPERATIVE PROCEDURE		19. NERVE GRAFTING OPERATIVE PROCEDURE		20. DATE		21. DISPOSITION			
22. ASSESSMENT OF RECOVERY (See instructions)		23. DATE		24. DATE		25. DATE		26. DATE	
27. DATE EN.		28. SIGNATURE OF SUBSCRIBER		29. SIGNATURE OF NEUROLOGIST		30. SIGNATURE OF NEUROLOGIST		31. DATE	

Figure 92.—Form used in Peripheral Nerve Registry. Left, front. Right, back.

INSTRUCTIONS

Items 1-3 To be completed from corresponding entries on clinical record (see also AR 90-105)

Item 4 If more than one of the indicated nerves is involved, a separate form should be prepared for each nerve. The block for "other" should be marked, and the fact that other nerves were also injured under item 19. Under the block for brachial plexus, individual or multiple nerve salures may be indicated by appropriate notation; the same notation may be made for other nerves, e.g., sciatic.

Item 11 The measurement of defect before surgery refers to the measurement of operation prior to any manipulation of the surgical defect remaining which necessitates procedures leading to end to end suture or grafting.

Item 12 The block for "other" should be marked only in the case of specimens clearly distinguishable from those specifically enumerated; in such cases, the description of the pathologic specimen should be entered in the space after the block for "other."

Item 13-15 The blocks are so arranged that those indicated to the right describe the operative procedure in increasingly greater detail. For instance, in item 13, the block for "with suture material" includes mobilization of the nerve, the first, third, ninth, tenth, and fourteenth blocks under item 13 should be marked. When some "other" procedure is involved, its nature should be entered in the space after the block for "other."

Item 15 The information called for under this item should be to the assessment of recovery as of the date on which the report is being submitted. The following codes should be used to indicate the degree of recovery.

NOTES

0 no contraction
1 power is present to act against resistance
2 plus return in distal muscles to such an extent that sufficient
3 simultaneous synergic and isolated movements

SENSORY

Usual Modalities

0 absence of sensibility in autonomous zone
1 recovery of some degree of superficial pain in a.z.
2 recovery of some degree of superficial pain in a.z.
3 recovery of some degree of superficial pain in a.z.

Electrical Stimulation

0 no response to galvanic current
1 reaction to depolarization (worm-like response)
2 weak or subnormal twitch to galvanic current
3 normal contraction

Skin Resistance

0 persistent area of increased skin resistance
1 increased skin resistance
2 normal skin resistance

When the above descriptions of (end boxes, the codes for) the assessment of recovery do not fully describe the situation, further comment should be made under item 18.

Item 16 Only cases which are CD's (or retired) or disqualified for overseas duty on account of nerve injury, should be marked under the blocks "top" or "retired a/c nerve injury" and "limited duty a/c nerve injury," respectively. All other assignments, except return to full duty, should be marked under "other." Cases which are disqualified for overseas duty for reasons other than the nerve injury, the block "other" should be marked.

Item 17 Time lost applies only to time in quarters and/or hospital while in military service during current assignments for the nerve injury.

Item 18 Comment should be made under this item regarding the influence of bone, vascular and soft tissue injuries. The presence of intraneural pathology, the possible influence of primary suture excess and any other factors which would tend to influence the results of the operation should be noted. (See item 19.) If a comment is desired, an extra page may be attached for reporting additional comment.

Item 19 In each hospital, the cases of peripheral nerve injuries on which reports must be rendered will be numbered consecutively; that is, individuals with injuries which require nerve suture or grafting will be given identifying numbers in consecutive order, as their records are submitted. In the case of an individual with injuries to several peripheral nerves, the block designated "nerve injury" should be marked in the case of each nerve. An X mark in the block designated "nerve injury" indicates that the individual was in the same hospital for examination or treatment of a peripheral nerve injury should receive the same number as the individual who was first admitted. A check on the completeness of the records received.

Item 20 To be signed by the neurosurgeon and dated as of the date the report is submitted.

careful observations recorded by trained neurosurgical personnel. Often, because of the pressure of work in combat areas and the large amount of paperwork necessary in all military hospitals, there were omissions.

The special form used (fig. 92), although necessarily detailed, was kept as simple as possible. A registry designed to record a potential reservoir of many thousands of cases naturally could not be devoted to minutiae. The recording of such very detailed data is a task for individual observers studying limited numbers of cases in personal series.

Analysis of Data

As cases were accumulated in the Registry,¹⁴ significant samples, ranging in number from 450 to 469, were analyzed by various methods. The period of observation in all cases analyzed ranged from 3 to 12 months. The results secured in 649 cases analyzed by statistical methods were compared with results of two groups of cases analyzed by a single individual (hand analysis). The first of these groups consisted of 450 cases. The second, which included the 450 cases first analyzed, consisted of 602 cases. The results in these hand-analyzed cases showed remarkably close correlation with the 649 cases analyzed by the statistical methods employed in the evaluation of all Registry cases.

The following conclusions were drawn from these various analyses:

1. The proportion of failures was far greater when nerve suture was performed at the time of debridement than when it was deferred until after delayed wound closure. These data fully substantiated the directives which had been issued during the war recommending that at debridement, surgery on the damaged nerve should be limited to coaptation or simple protection of divided nerve ends. The number of cases of primary nerve suture was of course small, but the evidence clearly pointed to the dubious value of this procedure.

2. Pathologic studies of Registry cases in which coaptation suture had been performed showed without much doubt that if such a suture was properly applied, it did not increase neural damage at the point of severance or in either segment, while, at the same time, it maintained the nerve in its normal anatomic plane and prevented retraction of the ends.

3. Failures in nerve suture performed after delayed wound closure were not frequent. They could be traced to two main causes, as follows: (1) Inept surgical technique and (2) inadequate mobilization, or no mobilization at all, of the extremity after nerve suture. In 9 of 16 suture-line disruptions in one of these analyses, for instance, the failures were directly attributable to improper mobilization of the extremity. In 17 neuromas of the suture line encountered in this analysis, it was possible to demonstrate the adverse effects of infection, intraneural sutures, tension on the suture line, unwise

¹⁴ Woodhall, B., and Lyons, W. R.: Peripheral Nerve Injuries. I. The Results of "Early" Nerve Suture: A Preliminary Report. *Surgery* 19: 757-789, June 1946.

selection of suture material, and inadequate resection of damaged nerve ends. There were also several failures in which errors in identification of nerve tissue again emphasized the importance of concentrating nerve injuries in neurosurgical centers for care by well-trained neurosurgeons. Another significant finding in the 602 hand-analyzed cases was the far larger number of failures in advanced units (22.4 percent) as compared with the number of failures in general hospitals (5 percent).

4. These cases indicated that nerve grafting was still a laboratory procedure unless it was limited to small nerves, such as the digital or facial nerves. It should not be regarded as a part of early nerve suture.

5. This analysis also clearly indicated the importance of detailed operative records and progress notes in peripheral nerve injuries. In the absence of positive evidence of regeneration, lack of positive data concerning the earlier procedure was a logical indication for secondary intervention.

6. In the first 450 cases analyzed by hand, 345 patients showed some degree of regeneration over periods covering from 3 to 12 months after operation, while 53 showed no evidence of regeneration. In 17 of the 53 apparent failures, the poor result could be explained by suture failure and in 2 others by failure of the graft.

The period of investigation, with 12 months as the maximum, while it was too short for the assessment of full nerve regeneration, was sufficient to show the trend of normal nerve growth. It was also ample to make frank failures manifest. From the standpoint of timing, the 44 failures which occurred in 602 cases analyzed by hand fell into 3 groups, as follows:

In 16 cases, repair was done at the time of debridement.

In three cases, repair was done at the time of delayed wound closure.

In 16 cases, repair was done shortly after delayed wound closure.

In the remaining nine cases, the failures were ascribed to causes which bore no relation to the time at which repair was done.

Addendum

By September 1945, 7,050 nerve sutures and 67 nerve grafts had been recorded in the Peripheral Nerve Registry (apps. E and F, pp. 611 and 633). The data varied greatly in detail and accuracy, chiefly because the Registry was a hurriedly planned wartime project, without careful prewar planning. Of the many difficulties inherent in the appraisal of neural regeneration in these injuries, not the least was the prolonged time interval which must elapse before regeneration can be fully assessed. The duration of the war, however, as well as the duration of hospitalization in many of the cases studied, permitted fairly adequate observation during the early months of nerve regeneration.

The average period of observation, on the other hand, was only 12 months, a period entirely inadequate to determine the end results of surgery. Had observation ended there, the World War II experience would have been

lost as hopelessly as the World War I experience was lost. Fortunately, the situation was quite different. The Conference on Postwar Research was called by the National Research Council in 1946 and was followed by a Peripheral Nerve Conference in January 1947. The plan for a followup project on peripheral nerve injuries was submitted to the Veterans' Administration, through the Committee on Veterans Medical Problems of the National Research Council and was recommended for financing in March 1947. Final planning was completed in November 1947.

The Veterans' Administration medical monograph entitled "Peripheral Nerve Regeneration—A Follow-up Study of 3,656 World War II Injuries," was published in 1957. The 2,554 men in whom these injuries occurred were followed up for a median period of 52 months. The cases are analyzed from a wide variety of viewpoints, varying from the timelag between wounding and operation to the training of the neurosurgeon who performed the operation.

The author of one of the forewords to that volume, Doctor Spurling, who served as Senior Consultant in Neurosurgery, Office of the Chief Surgeon, Headquarters, European Theater of Operations, U.S. Army, wrote as follows concerning it:

Every man, woman, or child who has seen war and its aftermath will hope prayerfully that the opportunity to study such large masses of battle casualties as are represented in this volume will never again occur. But, should future generations be faced by a similar catastrophe, this monumental work on peripheral nerve regeneration will ease the task of those who must care for these injuries and will assure the victims of another war better functional results than our generation of neurosurgeons has been able to achieve.

In other words, the significance of this volume on peripheral nerve regeneration is that the experience of World War II in the management of peripheral nerve injuries, unlike the experience of World War I, has not been lost.

CHAPTER XI

The Mediterranean (Formerly North African) Theater of Operations

*Eldridge H. Campbell, Jr., M.D.*¹

EVOLUTION OF POLICIES

At the beginning of the North African campaign, in the winter of 1942, neurosurgical policies and practices in this theater were those recommended by the National Research Council, which were essentially those in effect at the end of World War I. These recommendations were to let severed peripheral nerves strictly alone and not to undertake repair until several months after wounding. In line with this policy, the early repair of peripheral nerve lesions was not encouraged in the Tunisian campaign of 1942-43.

Even had the burden of surgical work been less, no other program would have been feasible at this time, for the management of soft-tissue wounds had not yet been stabilized. By the spring of 1944, however, delayed primary closure of soft-tissue wounds was an established policy in the theater and was followed by sound healing in practically all cases.

In the meantime, the results of occasional neurorrhaphies performed soon after wounding seemed highly promising. One such operation was performed at the 26th General Hospital, Bizot, Italy, by Maj. Lyle A. French, MC, in June 1943. At about the same time, Maj. (later Lt. Col.) Henry G. Schwartz, MC, discussed his experiences at the 21st General Hospital with four peripheral nerve injuries followed by causalgia and successfully treated by neurolysis alone or by resection and suture with neurolysis. The first of these operations was done in April 1943. In discussing them, Major Schwartz said: "Granting that professional skill is available and the indications exist, we raise the question whether any fixed time interval for nerve repair should be laid down."

PRIMARY REPAIR OF PERIPHERAL NERVE INJURIES

The whole question of management of peripheral nerve injuries was discussed at a meeting of neurosurgeons called 23 May 1944 by Col. Edward D.

¹ A consultant in neurosurgery was never formally appointed in the Mediterranean theater. When the need arose, Dr. Campbell, then a lieutenant colonel in the Medical Corps, represented the consultant in surgery to the Theater Surgeon. Gaps in this chapter are due to this fact; they could not be overcome because of Dr. Campbell's death while the history was in preparation.

Churchill, MC, Consultant in Surgery, Office of the Surgeon, Headquarters, North African Theater of Operations, U.S. Army.

The advantages of primary repair of injured nerves, which was discussed in detail at this meeting, were fully recognized, but it was generally agreed that they were outweighed by the disadvantages of this policy, among which were the following:

1. Past experience had shown that primary nerve repair was entirely impractical in military surgery during rush periods. It was a time-consuming operation, and it could be performed only by experienced neurosurgeons, whose time, when high priority casualties were numerous, could be more profitably occupied in lifesaving procedures.

2. Some patients were in such poor condition that they could not tolerate any but the most urgent procedures at the initial operation.

3. The results of primary repair were likely to be poor unless the operation was limited to wounds in which closure of the deep fascia would be satisfactorily achieved. Closure of the skin was not necessary.

4. The incidence of infection was appreciably greater when immediate suture was done in nerve injuries associated with compound fractures.

5. It was not easy at the first operation to determine how far pathologic changes might ultimately extend from the point of injury.

6. Lack of success was likely to be attended with serious consequences. Neuromas were almost inevitable under the circumstances, and additional length was lost by the additional resection necessary at secondary procedures. Moreover, failure might not be detected for many months, during which time all chances of successful repair might be lost.

In spite of these sound arguments, primary nerve suture was made permissive in certain carefully selected cases. The experience at the 15th Evacuation Hospital is probably typical of the small number in which it was employed. Definitive repair was originally thought to be possible in 92 of 168 nerve injuries in 150 casualties. It proved feasible in only 52 of the 92; 23 of these injuries were complete. After painstaking debridement of each wound, which consumed an average of 1¼ hours, the instruments were completely changed, and the damaged nerve was repaired. Local chemotherapy was not employed, but all patients received sulfadiazine by mouth. Later, when penicillin became available, it was used instead of sulfadiazine.

Immediate results were good. In the 10 to 14 days after operation during which these patients were under observation, only 3 instances of imperfect healing were described in the 52 injuries, all under the terms "late type," "mild," "noninvasive infection." The first followup observations, in 12 patients, were equally optimistic. Satisfactory recovery of function was apparently occurring in every instance. The experience was cited as showing what could be accomplished by primary nerve suture performed under auspicious circumstances by experienced neurosurgeons. The first observations, however, were admittedly casual, and long-term results did not

bear out the original optimism. Eventually, half of the operations were classified as failures.

The general experience of the Mediterranean theater indicated that the policy of primary nerve suture is unlikely ever to have a wide application in military surgery. The most that can be said for it is that when evacuation hospitals have long periods of relative inactivity, as sometimes happened in World War II, competent neurosurgeons may be permitted to employ the operation in favorable, carefully selected cases.

EARLY NERVE SUTURE

At the meeting called in May 1944 to discuss the management of peripheral nerve injuries, it was agreed that, under military conditions, the best policy for general use would be inspection of the damaged nerve at the time of initial wound surgery or delayed primary wound closure, with nerve repair a few weeks later. This policy was at once disseminated to all neurosurgeons in the theater, and the new program was undertaken on as wide a scale as the burden of work permitted.

Principles and Techniques

Certain aspects of the new program were promptly found to be important, as follows:

Records.—It was essential that records contain a concise but complete description of the observations made on the injured nerve at either initial or reparative surgery, preferably supplemented by a diagram which made clear whether the nerve was intact, partly or totally divided, wedged, or otherwise damaged. If a segment had been destroyed, the length of the defect was to be estimated, to assist in planning for subsequent repair.

Accurate knowledge of the structural defect was prerequisite to sound future treatment and accurate prognosis. If, for instance, a nerve which was still paralyzed at the end of 1 or 2 months was exposed and found intact, obviously another 4 to 6 months must be allowed to elapse before hope for spontaneous recovery was abandoned. If, on the other hand, operation was withheld on the erroneous assumption that the nerve had not been divided when it really had been, much valuable time would be lost and the ultimate functional result might be seriously prejudiced.

Visualization at initial wound surgery.—It would, of course, have been highly desirable to visualize the nerve lesion in all cases as promptly as possible; that is, at initial wound surgery. In spite of the interest and wholehearted cooperation of forward surgeons in the program, it proved impractical to identify the damage at this time, and therefore to describe it, in more than half of all cases. In most instances, the omission was of no great consequence, since the desired data could be obtained at the reparative operation in a general hospital 4 to 10 days later, usually with little additional dissection or retraction.

Exploration at reparative surgery was not attended with any risk in the absence of inflammation. If inflammation or infection were present, exploration was obviously contraindicated. In 55 consecutive operations at the 33d General Hospital in the early days of the new program, visualization of the injured nerve was carried out at the reparative operation with no lighting up of infection, and there was no evidence of increased fibrosis in any of these cases when neurorrhaphy was performed several weeks after the initial operation.

Management of nerve at initial wound surgery.—During World War I,² it had been suggested that severed nerve stumps be stitched together at the first operation, to prevent retraction, and this was done in a number of instances in the Mediterranean theater in the first months of the new peripheral nerve program. The value of this technique was highly debatable. When the nerve ends were examined at neurorrhaphy 3 to 8 weeks later, swelling frequently seemed to be more massive and more extensive than in cases in which preliminary suture had not been done. Retraction of the ends had been prevented, it is true, but the impression was gained that, at least in a number of cases, longer segments had to be resected before healthy neural tissue was reached than was necessary in cases in which suture had been omitted at the first operation. The result was that the gap to be overcome was not only no less than it might otherwise have been, which was one of the objectives of preliminary suture, but was actually greater. Deeply placed sutures, the resulting tension, and the drawing of the nerve into a more exposed position within the wound may all have contributed to these changes. Exposure of the nerve seemed to be particularly undesirable; it was observed on numerous occasions that portions of nerve stump exposed in the wound were considerably more reddened and swollen than other portions which, although they had been loosened within the wound bed, were covered by muscle.

For these reasons, makeshift suturing of divided nerves was not recommended, though the use of one or two fine silk epineurial sutures to anchor the nerve ends was permissible at debridement. It was strongly recommended that the nerve be protected with adjacent muscle or subcutaneous tissue at the first operation.

The local application of sulfonamide drugs was advised against, not only because of their reputedly irritating effect upon neural tissue but also because of the policy, which had by this time become general in the Mediterranean theater, of not introducing bacteriostatic or bactericidal substances into wounds. Penicillin had become available by the time the program was fully operative, and its routine administration was advised, in dosages of 25,000 units every 3 hours by the intramuscular route.

² The Medical Department of the United States Army in the World War. Surgery. Washington: Government Printing Office, 1927, vol. XI, pt. 1, pp. 866-1283.

A plaster splint, to include both adjacent joints, was also advised, to secure maximum rest for the part and to reduce nerve retraction.

Timing.—The optimum time for the repair of the damaged nerve was determined by correlation of the pathologic process in the nerve with the progress of healing in the soft-tissue wound. In the usual case, progress was as follows:

1. When the nerve was visualized at initial wound surgery or at delayed primary wound closure, 4 to 10 days after injury, the nerve ends were friable and edematous.

2. By the end of the second or third week after delayed primary wound closure, epithelization of the wound was complete, and organization of the underlying cicatrix was well advanced. If for any reason the wound had to be reopened during this period, vascularity was usually found to be rather pronounced. If the wound was large, areas of induration and edema were likely to be found both in it and about it. The nerve ends were usually swollen and rather friable, as at the reparative operation.

3. By the fourth week after wounding, adjacent tissues had usually become reasonably soft. Edema was likely to be minimal. Vascularity was still somewhat excessive, but fibrosis within the wound had not progressed to the stage at which dissection was difficult. Edema within the nerve trunks had for the most part subsided if it had not actually disappeared.

On the basis of these observations, the fourth or fifth week after successful delayed primary wound closure was usually regarded as the optimal time for nerve surgery. If, however, the nerve injury was complicated by a fracture, operation was deferred until stability had developed as the result of callus formation or had been achieved by internal fixation.

It would have been highly desirable to perform nerve repair in Zone of Interior hospitals rather than in the theater, but this was not practical. Because of associated injuries which made them nontransportable, as well as because of delays in evacuation and for other reasons, many patients could not have reached the United States until several months after wounding. If, therefore, one of the important considerations of the new program, the prompt performance of nerve surgery, was to be realized, nerve suture had to be carried out overseas whenever it could be accomplished.

Resection of damaged neural tissue.—One of the first things that a military neurosurgeon had to learn was that the extent of resection of damaged nerve tissue differed in civilian and military practice. In civilian practice, it had long been established technique to cut the injured nerve ends back to the point at which transected fasciculi stood out sharply. In wounds produced by high-velocity missiles, however, conservative resection was not sufficient. Early in the program, it became evident that epineurial fibrosis appeared within a few days of wounding and was far more extensive than in civilian-type injuries. It was most pronounced within the first centimeter on either side of the injury, but it extended backward, although to a lesser

degree, for several additional centimeters. Careful inspection of the neural tissue was necessary, for grossly normal nerve bundles were likely to be encountered for a considerable distance before normal epineurium was reached. On the other hand, if resection were carried back to normal epineurium, the surgeon might find himself confronted with a gap that seemed insurmountable. The decision was often delicate, for many failures could be attributed to clearly inadequate resection of damaged nerve tissue.

Nerve suture.—Approximation of the severed nerve ends was best accomplished by the well-established method of end-to-end anastomosis with epineurial sutures of fine silk, care being taken to avoid tension and rotation. Transneural stay sutures were not used because of the risk of subsequent intraneural scarring. The placing of radiopaque sutures in the epineurium on either side of the anastomosis was recognized from the beginning of the program as a desirable and dependable method of facilitating detection of postoperative distraction, but tantalum wire was not then available to carry it out.

In the Mediterranean theater, anastomoses were not protected by either tantalum foil or fibrin film. Convincing evidence of the effectiveness of these techniques in preventing fibroplasia had not yet been adduced, and some reports suggested that scar formation might actually be increased when they were used. So far as was known at the time, the best bed for a sutured nerve was a plane of clean, dry, scar-free, living tissue.

Management of extensive injuries.—Injuries in which there was extensive loss of nerve tissue presented special technical problems. Not infrequently, particularly in large avulsed wounds, long segments of nerve trunk had been destroyed, and a large gap remained, even after extensive mobilization of the nerve ends above and below the lesion, flexion of adjacent joints, or nerve transplantation. The use of nerve grafts was not regarded as warranted; reports concerning them had been extremely disappointing.

In many instances, therefore, sufficient length for repair could be gained only by bone shortening, a procedure which had been known for many years but which had not previously been generally used. It proved practical and not at all difficult. Observations on six patients at the 33d General Hospital in the early phase of the nerve repair program indicated that the loss of 1 or 2 inches of the shaft of the intact humerus interferes only very slightly with subsequent function. In any event, it was believed to be a small price to pay for functional recovery in, for instance, a median nerve injury.

When compound comminuted fractures were associated with extensive nerve injuries, shortening of the humerus was carried out either at the time of delayed primary wound suture or 4 or 5 weeks later, when the nerve was repaired.

Splinting.—While some support of the injured nerve was necessary after wounding and after reparative nerve surgery, prolonged fixation was highly undesirable and actually harmful; fingers and wrists readily became stiff and

even frozen. Braces were of little or no value except in wristdrop or foot-drop. Aside from the other undesirable features of more complicated apparatus, splints which combined simplicity of design with lightness and elasticity were the most useful kind for an oversea theater. An entirely desirable splint did not become available during the war.

STATISTICAL DATA

Accurate determination of the incidence of peripheral nerve injuries in the Mediterranean theater proved difficult. In forward areas, the heavy burden of work, particularly the necessity for focusing attention upon the salvage of life and limb, made it virtually impossible to record or even identify all cases, while the fact that many paralyzes were transient possibly vitiated some of the diagnoses made at the base. The incidence, however, was thought to be somewhat higher than the 2-percent incidence estimated for World War I.³ Data available during the war suggested that 5 to 8 percent was a more reasonable estimate for nerve injuries in World War II.

Peripheral nerve repair was more frequently applied to injuries of the upper extremity than of the lower (table 7), one reason being the large number of vascular injuries associated with nerve injuries in the lower extremity (p. 439).

TABLE 7.—*Anatomic distribution of 1,184 peripheral nerve injuries in 1,121 casualties treated in 3 hospitals in the Mediterranean Theater of Operations*

Nerve	15th Evacuation Hospital (150 casualties)	33d General Hospital (592 casualties)	26th General Hospital (379 casualties)	Total injuries
Ulnar.....	46	161	125	332
Radial.....	43	130	62	235
Median.....	37	84	55	176
Perineal.....	6	83	40	129
Sciatic.....	21	51	25	97
Brachial plexus.....	14	36	52	102
Tibial.....	1	18	17	36
Femoral.....		20	9	29
Saphenous.....		12		12
Axillary.....		6	3	9
Musculocutaneous.....		1	8	9
Not specified.....		4	14	18
Total injuries.....	168	606	410	1,184

Type of injury.—About half of all peripheral nerve injuries encountered in the Mediterranean theater were incomplete. Capt. (later Maj.) Donald H. Wrook, MC, in reporting on a series of 143 nerves inspected at initial

³ See footnote 2, p. 234.

wound surgery, stated that 58 were completely severed, 34 were partly severed, and 51 were lesions in continuity. These observations are in substantial agreement with observations at the 33d General Hospital.

The large proportion of incomplete nerve injuries, in which only neurolysis was necessary, further emphasized the importance of a clear record, preferably supplemented by a diagram, of the status of the injury as surveyed at primary debridement or reparative surgery (p. 223). It is easy to see that, without such a record, a large proportion of unnecessary reoperations might have been performed.

Multiple nerve injuries were frequent, the estimated incidence varying from 8 or 10 percent up to 20 percent. In one series of 102 successive casualties observed at the 33d General Hospital, 18 patients had more than 1 nerve injury. In 14 of these 18 cases, the injuries were in the upper extremities.

Concomitant injuries.—Compound fractures occurred in association with nerve injuries in a third or more of all cases. Maj. (later Lt. Col.) Joe M. Parker, MC, and Capt. Francis R. Crouch, MC, found that 40 percent of 271 compound fractures of the humerus managed at the 21st General Hospital were associated with injuries of the radial, ulnar, and median nerves. In 243 battle fractures of the radius, ulna, or both bones, the incidence of associated nerve injuries was practically the same, 39 percent. At the 33d General Hospital, the incidence of combined bone-nerve injuries was about 36 percent.

Concomitant injuries of major blood vessels in which gangrene did not develop occurred in 21 percent of 126 patients with nerve injuries studied at the 33d General Hospital; of 18 patients with more than 1 injury, 9 also had vascular injuries, bone injuries, or both.

CHAPTER XII

The European Theater of Operations

R. Glen Spurling, M.D.

EVOLUTION OF POLICIES

In the early spring of 1944, British neurosurgeons were still advocating the policy of watchful waiting for a return of function in major nerve injuries, with late exploration if spontaneous recovery did not occur. This policy was not in accord with recent experimental studies, or with the experience in U.S. Army hospitals in the Mediterranean theater. These data had clearly indicated that early suture of severed nerve trunks yields the most satisfactory end results. This did not, of course, mean primary nerve suture. However applicable this policy may be in civilian-type nerve injuries, and however sound it may be in theory, it was realized that it was both dangerous and illogical in war wounds. In these wounds, the contusion of the nerve ends which is inevitable after injury by a blunt missile does not permit accurate resection and repair at the time of initial wound surgery.

Experimental and histopathologic evidence, as well as the good results obtained in the Mediterranean theater, indicated that the optimum time for repair of a damaged nerve is between the third and the ninth week after injury. Repair accomplished between the 21st and 28th day was probably productive of the best end results and could be carried out with the least technical difficulty.

Still another reason for prompt exploration in every major nerve injury in which rapid clinical improvement was not occurring was the minimal operative risk (p. 250). Surgical exploration was the final step in diagnosis. If the nerve was found severed, valuable time was saved. If it was intact, neurolysis often hastened recovery. If no surgery was indicated, the patient was almost never the worse for the exploration.

TIMING OF NERVE REPAIR

In military practice, the selection and disposition of cases for operation was often necessarily modified by factors not related to the professional welfare of the patient. The chief of these difficulties concerned transportation.

Triage and Evacuation Overseas

The first phase of the peripheral nerve program of early repair was the formulation of plans for the prompt triage and evacuation of these patients from the Continent to neurosurgical centers in the United Kingdom. These objectives were accomplished on the basis of three considerations:

1. Repair of peripheral nerve injuries was practically always an elective operation.

2. Casualties with peripheral nerve injuries therefore could not be given a high priority for evacuation. In Circular Letter No. 81, Office of the Chief Surgeon, Headquarters, ETOUSA (European Theater of Operations, U.S. Army), 10 June 1944, neurosurgical priorities for evacuation from the Continent to the United Kingdom Base were assigned first to spinal injuries, second to penetrating injuries of the brain, third to closed cranial injuries, and last of all to peripheral nerve injuries.

3. Men with peripheral nerve injuries could seldom be returned to active combat duty, but they were operated on overseas only if evacuation to the Zone of Interior would be delayed.

From the standpoint of risk to life, the order of priority established for neurosurgical casualties was obviously justified. From the standpoint of the program of prompt repair of peripheral nerve injuries, it was very undesirable indeed. Even under optimum conditions of triage and evacuation in the period immediately after D-day, patients with peripheral nerve injuries, because of their low priority, seldom reached neurosurgical centers in the United Kingdom until 2 or 3 weeks after wounding. In the interim, they had passed through two or more general hospitals serving as transit installations, but, in spite of their delayed evacuation, many were arriving with their soft-tissue wounds still open.

A concerted effort was therefore made to expedite early wound closure, so that nerve exploration, with neurorrhaphy if it were found to be necessary, could be instituted promptly upon their arrival at neurosurgical centers. This objective was eventually accomplished, chiefly by means of conferences and personal contacts. When the program began to operate satisfactorily, the patient with a peripheral nerve injury, by the time he reached the United Kingdom, was in excellent condition for early nerve repair at the optimal time. His injuries had been debrided, in conformity with the regulations established for the management of soft-tissue wounds, and delayed wound closure had usually been done at some one of the installations at which he had halted temporarily in transit.

Evacuation to the Zone of Interior

Theoretically, because of the future unfitness of casualties with peripheral nerve injuries for combat duty and because of the necessity for keeping hospital beds in the combat zone and zone of communications free for other

casualties, it had been decided that most peripheral nerve repairs should be done in the Zone of Interior. As in the Mediterranean theater, however, military necessities did not always permit this ideal to be achieved, chiefly because facilities for evacuation were frequently limited and those which were available frequently had to be utilized for more urgent needs. If the original plan had been adhered to inflexibly, by the time many of the patients reached neurosurgical centers in the Zone of Interior, the optimal time for nerve repair would have passed, and the functional results would have been jeopardized, or at least would have been less good than they should have been.

The solution of the problem, then, was to correlate the optimal time for surgery with the available transportation. This was accomplished by the following methods:

1. Disposition proceedings were undertaken and completed in each case as soon as possible after the patient reached a neurosurgical center in the United Kingdom Base.

2. Patients with serious wound infections or with extensive soft-tissue injuries requiring plastic repair were evacuated to the United States as soon as transportation was available.

3. If transportation was available, other casualties with peripheral nerve injuries were also evacuated to the Zone of Interior as promptly as possible.

4. If transportation was not available, or if, for any other reason, including complicating injuries, evacuation was undesirable, the waiting period was utilized for the repair of peripheral nerve injuries. The patients were then evacuated as soon after operation as their condition permitted and facilities were available.

Neurosurgical Personnel

The shortage of neurosurgical personnel played a role in the timing of repair of peripheral nerve injuries. The number of trained neurosurgeons available to handle the heavy casualty load was always inadequate. The deficit was met in two ways: (1) By the use of a number of general surgeons who had had some training in traumatic surgery in the Zone of Interior, and (2) by the use of general surgeons of sound training who were rapidly instructed in fundamental neurosurgical principles. These two supplemental groups of surgeons were assigned to special neurosurgical centers, in which they worked under chiefs of service who were formally trained in neurosurgery and who had usually had considerable experience in this specialty in civilian practice. The centers were under the continuous supervision of regional consultants in neurosurgery, who in turn maintained intimate contact with the senior consultant in neurosurgery. The entire program could thus be unified by standardization of diagnostic and therapeutic methods.

It is not too much to say that it was the resourcefulness and energy of the young general surgeons who were suddenly called upon to become profi-

cient in neurosurgery that made possible the handling of so many peripheral nerve injuries so well within the optimum period for repair.

PRINCIPLES AND TECHNIQUES

Initial Wound Surgery

The Manual of Therapy for the European Theater of Operations,¹ which was issued 5 May 1944, outlined the following plan of management for peripheral nerve injuries. It is interesting to note that these general principles required no substantial alterations in the year of heavy fighting which followed.

1. Injury to one or more of the major nerve trunks should be regarded as a possibility in every wound of the extremities. Simple tests for motor and sensory function should be used to determine which nerve (or nerves) is involved.

2. The existence of a nerve injury does not warrant any departure from the regulation management of soft-tissue wounds; that is, initial debridement and delayed wound closure.

3. If the severed nerve ends are visualized when debridement is done, they should be approximated whenever possible. If the gap does not permit approximation, the ends should be snugly anchored to surrounding soft tissue. Fine stainless steel or tantalum wire should be used for suture material, both being useful for later roentgenologic demonstration of the location of the injury and the extent of the defect. The purpose of the initial suture or temporary anchoring of the nerve ends is to prevent the retraction which greatly complicates later end-to-end suture. Elaborate primary nerve suture should not be attempted.

4. The soft-tissue wound should, as usual, be left open, to be closed at an appropriate time in an installation farther to the rear. The muscles or fascia should be approximated loosely over the exposed nerve trunk. A pack should never be placed over an exposed major nerve trunk.

5. Splinting is usually a preliminary requirement for transportation. About half of all nerve injuries are associated with injuries to one or more of the long bones, but, even in the absence of bone injuries, the extremity should be immobilized in the most favorable position to prevent deformity. This can usually be achieved with bandages, blankets, or rolls of clothing; casts and elaborate splints are seldom required for evacuation. Protection of an extremity deprived of sensation is, however, essential.

6. An extremely important phase of preevacuation management is the careful recording of the condition of the injured nerves at the first observation and a statement concerning exactly what was done at debridement. The

¹ The sections of this manual devoted to neurosurgery are reproduced as app. B in Medical Department, U.S. Army, Surgery in World War II. Neurosurgery, Volume I. Washington: U.S. Government Printing Office, 1958, p. 403.

notes can be written either on the emergency medical tag or on the cast. Lack of these data may delay subsequent surgery or result in unnecessary nerve exploration.

Definitive Nerve Surgery

Every neurosurgeon who participated in the peripheral nerve repair program was carefully instructed in the generally accepted principles of nerve surgery, with particular emphasis upon the following points:

1. If the nerve was not divided, a policy of strict conservatism was observed, the operation usually being limited to neurolysis.
2. The proximal and distal nerve ends were accurately trimmed back until grossly normal neural tissue became apparent.
3. The transected nerve ends were approximated by a very carefully performed interrupted epineurial suture.
4. The suture line must be free from tension. This objective was usually accomplished by as extensive dissection as was necessary. Transplantation of the proximal and distal nerve segments was preferable to excessive or unphysiologic flexion of contiguous joints.
5. Tantalum wire (0.003 inch) swaged upon atraumatic needles was recommended but was not mandatory for the sutures. If the surgeon preferred fine silk, he was at liberty to use it. The wire sutures, however, were considered superior to other materials for several reasons. One was that experimental studies had shown wire to be inert in human tissues. Another was that, even at the beginning of the program, it was surmised that disruption of the repair might present a problem, which would be simplified by early roentgenologic studies of a radiopaque suture line. When the necessity of later evaluation of large numbers of patients submitted to nerve suture is borne in mind, the importance of this precaution is manifest. Preliminary surveys in the European theater testified to the validity of this reasoning.
6. Strict hemostasis was mandatory. It was to be accomplished without the use of a tourniquet unless an associated vascular injury made mechanical control of the blood supply necessary.
7. A small cuff of tantalum foil (0.00025 inch in thickness) was placed about the suture site in almost all nerve repairs carried out in the European theater. In one center, a plasma clot sheath was used, the variation being permitted because experimental studies had suggested that the method might be valuable and a comparison of this technique with other methods of protecting the suture line seemed warranted.

Correspondence between the senior consultant in neurosurgery in the European theater, Col. R. Glen Spurling, and the consultant in neurosurgery, Office of the Surgeon General, Lt. Col. Barnes Woodhall, indicated that the use of tantalum cuffs was not harmful and was probably useful. Followup studies indicated that regeneration had occurred rather consistently

when they had been used in end-to-end sutures and that they had also been useful when the scarred area of nerve was protected by a cuff after neurolysis. A report from the neurosurgical center at Cushing General Hospital, Framingham, Mass., early in 1945 suggested that the use of these cuffs was harmful; many of them had had to be removed, and some of them had been found to be fragmented when the secondary operation was undertaken. Neurosurgeons in the European theater were therefore instructed to be careful in the application of these cuffs and to use no ties about them. The original technique of annealing the foil was also altered, and it was merely curled about a piece of rubber tubing, as one would roll a cigarette, in warm saline solution. The report from Cushing General Hospital about the risks of tantalum cuffs was the only such report received.

Postoperative Management

Casts were forbidden for the correction of deformities due to nerve injuries except during the immediate period of immobilization necessary after operation.

Extension of the flexed joint was usually begun at the end of the second week after operation and was completed by the end of the fifth week. The timing was considered safe because of the comparative freedom from extensive fibrosis observed in patients treated by early nerve suture. It also had the practical advantage of reducing the period of oversea hospitalization and thus permitting evacuation to the Zone of Interior within the holding policy of the theater.

There was no doubt that the prolonged use of any sort of cast or splint was an obstacle to prompt and satisfactory functional recovery. On the other hand, neuropathologic studies showed that suture-line disruption sometimes occurred when the policy of early mobilization was employed, and it may be that discretion was not always used in its application. A followup study of one series of 650 peripheral nerve injuries in the Zone of Interior showed an incidence of rupture of the suture line of about 4 percent. This was not regarded as unduly high; in fact, it compared very well with the incidence noted when the suture line was protected from much longer periods of time. The many variables which entered into the situation made definite conclusions impossible, and the optimum time for joint extension was still under debate when the war ended.

COMBINED BONE AND NERVE INJURIES

Wounds of the extremities with combined injuries of major nerve trunks and fractures of the long bones comprised a considerable proportion of battle wounds encountered in general hospitals. In the past, the functional results of these injuries had been highly unsatisfactory. In the early part of the European campaign, as in the North African and Mediterranean fighting,

they were handled on orthopedic services, with the primary objective of securing correct alinement of bone fragments by the usual treatment for fractures, including reduction, manipulation, and plaster immobilization or skeletal traction. As a result of this policy, most casualties with combined bone and nerve injuries were not sent to neurosurgical centers for treatment of the nerve lesion until 8 to 16 weeks after injury. Then, because of the theater holding policy, most of them had to be returned to the Zone of Interior for definitive treatment of the nerve injury. Many arrived with immobile joints and atrophied, paralyzed muscles, and end-to-end suture of the severed nerve had proved impossible in about 20 percent of all cases.

Surgical management.—In December 1944, in cooperation with Col. Mather Cleveland, MC, Senior Consultant in Orthopedic Surgery, Office of the Chief Surgeon, ETOUSA, a program was instituted in the theater to provide prompt combined treatment of nerve injuries associated with fractures of the long bones, as follows:

1. Early triage was the first consideration, so that patients with these combined injuries could be transferred to neurosurgical centers while still in the casts or splints in which they had been placed immediately after wounding.
2. Once the patients reached the centers, every effort was made, through the cooperation of orthopedic surgeons, plastic surgeons, and neurosurgeons, to facilitate early repair of the damaged nerve.
3. The soft-tissue wound was closed by the usual routine.
4. The injured nerve was treated by suture or lysis as soon as possible after healing of the soft-tissue wound, while, at the same operation, the orthopedic surgeon carried out whatever procedure was indicated on the fractured long bone.
5. The elective operation was performed, as a rule, within 3 weeks after healing of the soft-tissue wound. In the interim, as soon as the original plaster had been removed, the extremity was placed in balanced skeletal traction.

This routine facilitated management of the fracture and also provided the optimum conditions for dealing with the soft-tissue wound by simple delayed closure or, if necessary, by an appropriate plastic procedure.

Adjunct therapy.—Penicillin or sulfadiazine was administered for 24 hours before, and for 72 hours after, the delayed wound closure. A booster dose of tetanus toxoid was given before the combined bone-nerve operation.

Physical therapy, including daily electrical stimulation of paralyzed muscles, was instituted as soon as the patient arrived at the neurosurgical center and was continued throughout the period of hospitalization. Plaster was used for immobilization after the bone-nerve operation, whether or not internal fixation had been employed, but a window was cut in the cast over the muscle belly to allow for electrical stimulation. During the postoperative period, every effort was made to encourage active and passive motion of the joints, particularly the small joints.

Evacuation.—After V-E Day, when a holding policy of 60 days was instituted in the European theater, patients with complicated nerve and bone injuries had to be evacuated to the Zone of Interior for treatment. Simpler combined injuries continued to be handled in the theater. Attempts were made, however, to complete the closure of all soft-tissue wounds before evacuation.

Results.—Approximately 300 combined injuries of the major nerves and long bones were treated according to this routine in the European theater, within an average period of 6 weeks after injury. About 10 percent of the patients required shortening or internal fixation of the fractured bone, and about 60 percent required end-to-end nerve suture. In the remaining patients, the nerve was found intact, and simple neurolysis was sufficient. In a sample studied at one neurosurgical center, approximately three-quarters of the combined bone-nerve injuries were in the upper extremities and approximately a quarter in the lower. The incidence of complications, particularly wound infection, was negligible during the period the patients remained under observation in the European theater.

So far as is known, this was the first time in the history of surgery that a large series of patients with combined bone and nerve injuries were subjected to early, simultaneous operation.

PHYSICAL THERAPY

No opportunity was lost of emphasizing to all medical officers and all others who participated in the peripheral nerve program that the surgical procedure was only a single stage in the treatment of the paralyzed extremity. However satisfactory the nerve repair and subsequent regeneration might be, an extremity would continue to be functionally useless if temporarily denervated muscles were permitted to become irreversibly atrophied or fibrosed or if joints of the wrist, hand, ankle, fingers, or toes became irreversibly frozen.

The excellent results obtained in the peripheral nerve injury program in the European theater were due at least in part to the expansion of the physical therapy service proportionately with the neurosurgical load. The Chief Surgeon's Office cooperated fully in this expansion, by the authorization of additional space and equipment, by the assignment of available Army personnel in excess of Table of Organization specifications, and by permitting the employment of trained British civilian personnel whenever possible. As a result, the physical therapy service became one of the most important departments of every neurosurgical center.

Experimental and clinical studies had indicated that daily galvanic stimulation of denervated muscles would prevent atrophy and retard fibrosis. This measure was therefore employed as a routine in all cases, beginning with 15 brisk contractions daily and progressing gradually to 30 contractions. When casts were used for postoperative immobilization, windows were cut

in them over the bellies of the paralyzed muscle groups, and galvanic stimulation was begun the day after operation. Other measures included massage, active and passive motion, and the use of dry and moist heat as indicated. Particularly careful attention was given to the active and passive motion of small joints. The excellent results obtained by this practice in patients with combined nerve-bone injuries raised the interesting speculation that it might be advisable to cut windows over the bellies of all muscle groups in extremities immobilized for any considerable period of time and to practice galvanic stimulation, regardless of the basic lesion.

Fixation by splints, as already indicated, was kept at a minimum. It was considered of the greatest importance to give the patients detailed instructions concerning the care of their own joints. No patient was considered ready for evacuation until all his joints had been fully extended, which, on the average, could be accomplished within 3 to 5 weeks after nerve repair. If, however, he was not carefully instructed in constant movement of the joints, passively as well as actively, he was likely to arrive in the Zone of Interior with frozen joints, particularly the joints of the hand.

STATISTICAL DATA

Earlier in the war, during the fighting in the Mediterranean theater, many neurosurgeons had been somewhat hesitant over applying the principles just outlined for the management of nerve injuries to battle casualties. Even the most skeptical, however, were apparently convinced of their wisdom and safety by the demonstration during the Italian campaign that open granulating soft-tissue wounds could be closed within 7 to 10 days after wounding, with resulting primary healing, so that elective neurosurgical repair could be undertaken within the optimum time period after wounding without fear of serious wound infections. The European campaign presented an opportunity to test the program on a large scale.

Of 6,245 major peripheral nerve injuries treated in general hospitals in the United Kingdom in the approximately 11-month period between D-day and V-E Day (table 8), 2,873 (46 percent) were operated on overseas within the period designated as early; that is, within 21 to 90 days after wounding. The remaining injuries were treated in the Zone of Interior for a variety of reasons, the most frequent of which was the inability of the neurosurgical centers abroad to handle larger surgical loads within the optimum time limit for surgery. The increase in the volume of patients operated on overseas as time passed is noteworthy. In spite of the increasingly heavy patient load, the proportion rose from just over 34 percent in the 8 weeks after D-day to more than 50 percent in the 6 months before V-E Day.

In almost 47 percent of the cases in which surgery was done, the nerve was found intact, and neurolysis, usually external but occasionally internal, was done. In the remaining cases, the operation consisted of end-to-end

TABLE 8.—Essential data in 6,245 peripheral nerve injuries observed in the European Theater of Operations, D-day to V-E Day

Essential data	D-day to 1 Aug. 1944		1 Aug. to 1 Nov. 1944		1 Nov. to 1 Feb. 1945		1 Feb. 1945, to V-E Day		Total	
	Number	Percent	Number	Percent	Number	Percent	Number	Percent	Number	Percent
All injuries-----	756		1,871		1,504		2,114		6,245	
Operations-----	259	34.3	780	41.7	754	50.0	1,080	51.1	2,873	46.0
Timelag (average in days)-----	28		41		42		42		39	
Procedures:										
Neurolysis ¹ -----	111	42.5	320	41.0	385	51.0	529	49.0	1,345	46.8
Neurorrhaphy-----	148	57.5	460	59.0	369	49.0	551	51.0	1,528	53.2
Type of suture:										
Silk-----	2	1.4	5	1.0	3	.8	4	.7	14	.9
Tantalum-----	146	98.6	455	99.0	366	99.2	547	99.3	1,514	99.1
Cuff (tantalum)-----	133	90.0	414	90.0	322	87.3	526	95.5	1,405	91.3
Wound healing:										
Primary-----	254	98.0	764	98.0	743	98.5	1,064	98.5	2,825	98.3
Secondary-----	5	2.0	16	2.0	11	1.5	16	1.5	48	1.7

¹ The proportion of cases in which only neurolysis was necessary makes clear the importance of a written record, or, better, a diagram of the nerve injury, as surveyed at primary debridement, to avoid unnecessary exploration later.

suture, which is the most desirable method of treating divided nerves. The fact that this technique could be applied in almost every case in the series in which it was indicated is evidence of the soundness of the whole program of early nerve suture. The number of insurmountable gaps in the group of cases under consideration from the European theater was less than 1 percent, whereas in a series of similar cases operated on in the Zone of Interior after the North African campaign it was about 10 percent. The improvement is significant, for the alternative of elective bone shortening to facilitate end-to-end suture, while it is practical, is not a desirable procedure if it can be avoided, and most nerve grafts are clinical failures.

Early nerve suture, moreover, was proved to possess at least three major advantages over delayed suture, as follows:

1. Mobilization of the proximal and distal nerve segments was much more readily achieved.
2. Fibrosis in the wound, and particularly in the nerve stumps, was greatly reduced.
3. Flexion of contiguous joints was more easily accomplished.

The timelag between wounding and neurorrhaphy in this series varied from an average of 28 days in the period immediately after D-day to 42 days in the period between 1 February and V-E Day. The average of 39 days for the whole series is longer than the most desirable interval, which is 21 to 28 days after injury, but is still well under the upper limit of 90 days. Associated injuries and late closure of the wound accounted for many of the delays in definitive neurosurgery, but the most frequent reason was the difficulties encountered in evacuation from the Continent, particularly during the winter months when air evacuation was often hampered by bad flying conditions.

On the other hand, the timelag does not seem unduly long when one recalls that, in the interval, the patients had been removed from the front-line and transferred to various installations along the line of evacuation on the Continent before they finally reached the neurosurgical centers in the United Kingdom. On the whole, the 39-day average probably represents the shortest practical period within which definitive neurosurgery can be done on large groups of casualties under conditions of active warfare.

That primary wound healing occurred in more than 98 percent of the cases is itself convincing testimony concerning the wisdom of delaying neurosurgery for 3 to 4 weeks after debridement of the initial wound. The policy of early nerve stretching, however, was possibly somewhat overemphasized (p. 244).

Many of the simpler injuries in the series were operated on under local (procaine) infiltration analgesia. Operations on the sciatic nerve were usually performed under spinal analgesia. All brachial plexus injuries and many combined injuries of the upper arm were handled under intratracheal ether anesthesia.

The single death in the 2,873 operations followed local nerve block, in preparation for exploration of a common peroneal nerve lesion, and was presumably the result of a procaine hydrochloride (Novocain) reaction. The fact that nearly 3,000 consecutive major neurosurgical operations could have been performed with so low a case fatality rate is ample testimony to the competence of the anesthesiologists, particularly when it is remembered that neurosurgical procedures are necessarily complicated and prolonged, and that as long as 5 hours may be required for a single operation.

At the beginning of the program, early nerve surgery was carried out only in the injuries in which bone complications were not present. Later, as already mentioned, combined injuries were brought under the same program. The regimen included debridement and delayed wound closure, balanced skeletal traction for immobilization, combined operation by the neurosurgeon and orthopedic surgeon, antimicrobial therapy, and preoperative and postoperative physical therapy.

CHAPTER XIII

Standard Methods of Examination in Peripheral Nerve Injuries

Frederic H. Lewey, M.D.

This chapter concerns methods of examination found useful in the neurologic-neurosurgical center at Cushing General Hospital, Framingham, Mass., in which, at times during World War II, large numbers of patients with peripheral nerve injuries required immediate diagnosis and prompt decision concerning treatment. The routine which was developed insured a thorough and sufficiently complete workup by the use of a limited number of simple, practical, rapid, and objective methods.

The aim of these methods was twofold: (1) To shorten the time of hospitalization and (2) to express the results of the examination in numerical terms. The latter objective was of special importance, since, in military practice, each patient's motor power and sensibility frequently had to be assessed by different investigators in subsequent followup studies.

GENERAL CONSIDERATIONS

The routine at Cushing General Hospital was established on the basis of the following considerations:

1. The individual yardstick for what is designated as "good," "fair," or "poor" function always varies with the increasing experience of the same physician and varies still more from one examiner to the next. The expression of one's estimate in percentage of the normal without a better basis than an impression is never justifiable because it pretends an exactness which is not warranted.

2. The presence or absence of improvement in such properties as muscular strength, sensitivity, and electrical irritability of muscles and nerves determine the expected course of a nerve lesion.

3. The importance of reasonably exact and reproducible measurements as criteria of the functional condition of a nerve cannot be overrated. The slightest indication of motor or sensory improvement, if reliable, may prevent an unnecessary operation; if it is unreliable, it may delay nerve repair and restitution of function for months.

4. It is well understood that no measurement in which human factors enter will be truly exact; observational error is on the one side and the

patient's ability at judging his sensations, as well as his skill in demonstrating his true muscle power, is on the other. Standardization of the methods of examination and adequate objective controls will minimize but cannot completely nullify errors. Experiences at this neurosurgical center repeatedly showed that the results of three independent observers, who used the methods to be described and the same standardized techniques, were in reasonable agreement and that the values obtained in subsequent examinations of the same patient were sufficiently significant to permit sound judgment concerning further procedures.

5. Nerve regeneration is a slow process, often requiring years even under favorable conditions. Every effort on the part of the neurologist and neurosurgeon was therefore directed toward shortening this period of restitution. A correct appraisal of the initial findings contributed greatly to this task. There was seldom doubt concerning the treatment of the small number of patients returned from overseas with the definite statement that a nerve had been seen to be interrupted and had not been repaired at the time of the delayed primary closure of the wound, but in the majority of patients, unfortunately, no reliable data were available concerning the anatomic condition of the paralyzed nerve. There was often doubt, therefore, whether it was sufficiently injured to need surgical repair or, on the contrary, whether it was capable of spontaneous recovery.

6. Clinical observation was always the best test of nerve regeneration, but it had to be used judiciously, so that the examiner would not be deceived by the host of trick movements which patients develop unconsciously. If motion is present in a muscle group, continued increase of strength should be demonstrable. The same could be said for the sensory disturbance in the distribution of the injured nerve.

Erroneous conclusions were easily drawn from correct observations and recordings. One read frequently, for instance, in the chart of a patient with an ulnar paralysis, followup statements extending over months to the effect that strength and sensitivity had improved more and more until eventually the absence of abduction and lack of sensation in the little finger were the only residuals of the paralysis. Actually, these two signs represented the only intrinsic deficit which had ever been present. All other initial disturbances had been situated in the overlap area of the median and radial nerves, which gradually assumed some of the ulnar functions. In other words, the improvements, which were correctly recorded, had no bearing on the ulnar nerve lesion, which was just as complete after months of observation as in the beginning and which should have been repaired immediately.

OBJECTIVES OF THE EXAMINATION

Four basic questions had to be answered as early and as precisely as possible concerning all peripheral nerve injuries in World War II, as follows:

1. Was the injured nerve completely or partially interrupted?

2. Was the nerve in continuity, but with too many of its fibers interrupted intraneurally to permit spontaneous recovery?

3. Could a paralyzed nerve be left alone with the assumption that it was only bruised and would recover spontaneously?

4. Had a nerve suture been successful?

All the methods of examination described in this chapter were selected to provide material for the replies to these questions.

INITIAL INVESTIGATIONS

The Clinical History

All patients were seen within 24 hours of admission, although sometimes, when convoys brought groups of 20 or more patients at once, only in a cursory way at this time.

Two of the younger ward officers were detailed for the first examinations. They took the history of the injury and of previous treatment and abstracted all pertinent data from the records accompanying or following the patient.

Deciphering of an oversea chart, scribbled with pencil in odd places, was a tedious job. It was done so completely the first time that the task did not have to be duplicated.

The checklist contained the following items:

1. Operative findings and procedures, copied verbatim, with reproduction of sketches and photographs.

2. Extent of the initial motor and sensory paralysis, as well as exact dates and extent of each subsequent stage of improvement.

3. Whether or not the nerve had actually been seen or explored and, if so, its appearance during primary treatment and secondary closure of the wound.

4. Whether the nerve stumps had been tagged and how.

5. Injuries to, and ligation of, larger blood vessels.

6. Interruption of tendons and extensive loss of muscles and of other soft tissue.

7. Bone or joint injuries.

8. The number and type of hospitals which the patient had passed through, with the names of surgeons who had performed operations or made pertinent statements. It was soon found that operations, statements, and suggestions by certain neurosurgeons overseas could be taken at face value even though the time elapsed was too short for confirmation or though they seemed to be at variance with the current findings.

All dates and statements were checked with the patient. Any additional information was characterized as such. Contradictory statements were also recorded as such, though those made by patients were not overrated. It was surprising how often intelligent men had not been interested enough to inquire who had operated on them and what had been found or done.

Data which were pertinent in the opinion of the examiner and which could not be found in the chart or verified by the patient were specifically noted.

Exploration.—Exploration of the paralyzed nerve proved to be the wisest procedure in patients who had been observed or operated on by physicians unfamiliar with neurosurgical work if no sign of recovery of function or regeneration of nerve could be traced at the time of admission. In a certain number of patients, the exploration was found to be unnecessary. More often, the findings on personal inspection were in sharp contrast to the description on the chart. Nerves reported to be intact were found completely interrupted. Other nerves were seen to be sutured to tendons or blood vessels. Simple exploration in the hands of a competent neurosurgeon is a minor and harmless procedure. It was not refused by any patient after its implications had been explained to him.

Neurologic Examination

Plaster casts were removed at once unless they had been applied for recent fractures. A qualitative motor and sensory examination followed, for first orientation. Slips were filled out for all routine and special laboratory and X-ray examinations. Thereafter, the patient and his chart were presented to the chief of section for discussion of the results. The examiner filled out SGO Form 55-E-10A on the typewriter, with a carbon copy, while the final motor and sensory examinations described later were performed by the specially trained personnel. A complete examination took from 2 to 4 hours, and occasionally more, depending on the complexity of the case and the number of required tests, and this plan saved time and gave more reliable results. Ward officers, however, were urged to learn the various special methods of examination.

Recording.—Experience in World War I had taught that many charts were lost in the course of events through the chain of hospitalization or that, at least, important forms disappeared from them. This fact was verified in World War II. To make and keep a copy of each chart was small extra work. Time was also saved by this plan when patients returned from work furlough for a routine checkup. It took just a few minutes to get the duplicate chart from the file cabinet, to examine the patient, and to add the result to the chart. The copy was retained for his original chart, which came through messenger mail from the registrar, often after the patient had returned to his work.

The statisticians initiated a filecard (figs. 93 and 94) based on the prepared chart and checked it for completeness in both the original record and the copy. The copy was retained in the department's file cabinet. The original chart with the filecard clipped to it was delivered to the chief of section for preparation of the weekly combined neurologic-neurosurgical, orthopedic, and medical conference.

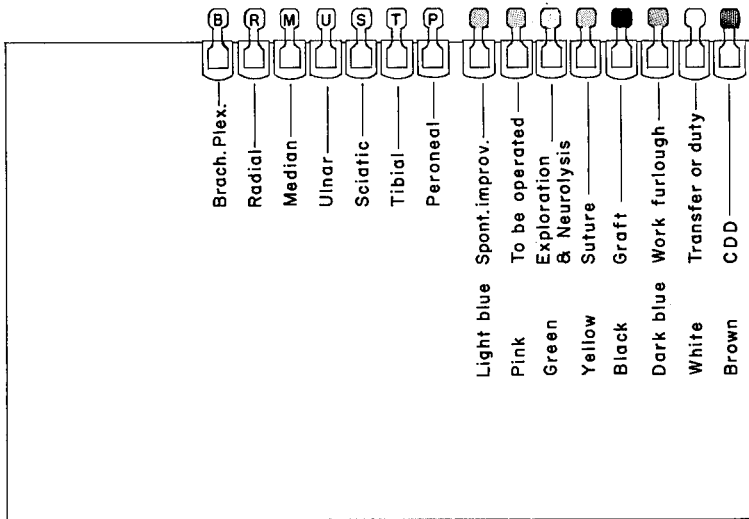

FIGURE 93.—Diagram showing method of indicating by type and position of riders on filecard the particular nerve injured, the means of recovery (spontaneous versus surgical), the treatment employed, and the immediate and ultimate disposition of the patient. Immediate checking of the patient's total status was thus possible.

Name	Gr. Sgt.	ASN	Inj. 9 June 1944	July 1
Age	27			
Address:			Prev. Oper. -	Trf
1. DIAGNOSIS: Ulnar, left		3. OPERATION: Explor. Lysis. Suture. Graft. Cuff. Tantal.		
Injury Section by glass		9 July '44 (Capt. Scoville) Resect. of " rem. 5 Jan. '45		
mot. Complete		small neuroma & glioma, transposition, end to		
sens. "		end sut. over 3/4" gap.		
caused by Fall on maneuvers		Electr. Motor 1.5" bel. sut.: Fl. p. IV, V, rest 0		
Atrophy ++++ all ulnar muscles, see print		" Sens. " " " : Pain in 5th dig.		
Electr. Exam.		4. RECOVERY: 23.VIII 27.XI.45 17.VI.46		
Spont. Recov. 0		18.V.45 0 Ad. p. 20% Abd. V. Ad. p. 30% Abd. V. 20%		
Sympath. Invol. 0		+ + + + Inteross. I: 20%		
Other: 0		sens. 0 0 Palm Dig. 0 Dig. V: Hypalg. " esth.		
2. TYPE & PLACE OF INJURY 2" ab. elbow, med. side		Intraneur. Abd. V, Inteross. I: + +		
Interrupt: ✓ 3/4"		EMG% 5 12 20		
Scar: - intraneur. extra		CHR. msc 28 16 8 2		
Bruise -		KCT. mA 20 17.5 15		
Second Sect. ✓		First Signs of: 16 July '45 Oper. Rep. ✓		
Other: 16" → ABD. V.		Final Recov.: " Overseas 0		
		Growth Rate: 3/4" /m Ankylosis 0		

PRINTED IN OCCUPATIONAL THERAPY

FIGURE 94.—Specimen filecard of patient with interruption of left ulnar nerve (first rider, treated by suture (second rider, yellow on original card), sent on work furlough (third rider, dark blue on original card), and eventually discharged (fourth rider, brown on original card).

The methods of examination described were so selected that the necessary devices could be readily made by any mechanic or bought in any hardware store. Graphic records were drawn on stencils and mimeographed. In this way, blanks were prepared for sensory and motor recordings (fig. 95). Large figures were found to be essential. Sensory entries were made with black, blue, and red pencil, to give instantaneously a clear visual picture of the condition. Verbal descriptions were given in unequivocal terms. To give only one example, fingers were named, not counted; index, middle, ring, and little fingers are specific terms.

QUANTITATIVE EXAMINATION OF SEQUENCE OF RETURNING MOTOR FUNCTION

Figure 96 shows the forms used for ulnar, radial, median, sciatic-tibial, and peroneal nerve injuries. They show the nerve branches to a few muscles whose isolated function can be easily tested. The forms were blocked on cardboard, on which the directions for their use were printed. As soon as a muscle, previously paralyzed, showed beginning action, this date was written in the corresponding space, together with a number indicating whether motion resulted (1) from voluntary contraction, (2) electrical stimulation on the intact skin, or (3) intraneural stimulation. If, for example, in a radial paralysis concomitant with a fracture of the humerus, only triceps function was present initially, but if the brachioradial was found contracting at a later date and the extensor carpi radialis followed in due time, it became clear that the nerve was regenerating and needed no surgical intervention. Figures 113, 119, 121, and 123 show records of patients with various nerve injuries. The figures were drawn true to scale, as far as possible, and permitted ascertaining with sufficient accuracy the ratio inches/months, meaning the distance from the lesion to the muscle examined, over the number of months from the date of injury to the first observation of muscle movement. This form, in contrast to figure 95, does not reckon the degree of muscle strength, but checks the orderly progress of the nerve regeneration from the place of injury to the most distant muscle. It could be filled in without the use of any instrument.

QUANTITATIVE ASSESSMENT OF STRENGTH OF MUSCLES OF HAND AND FOOT

Origin, meaning, and reliability of test.—The use of the spring scale (fig. 97) for measuring muscle strength seems to have been introduced into medicine by Lovett¹ and developed on his instigation by Martin.² Pollock³

¹ Lovett, Robert W.: *The Treatment of Infantile Paralysis*. 2d edition. Philadelphia: P. Blakiston's Son & Co., 1917.

² Martin, E. G., and Lovett, R. W.: *A Method of Testing Muscular Strength in Infantile Paralysis*. *J.A.M.A.* 65: 1512-1513, 30 Oct. 1915.

³ Pollock, Lewis J., and Davis, Loyal: *Peripheral Nerve Injuries*. Hoeber's Surgical Monographs. New York: Paul B. Hoeber, Inc., 1933.

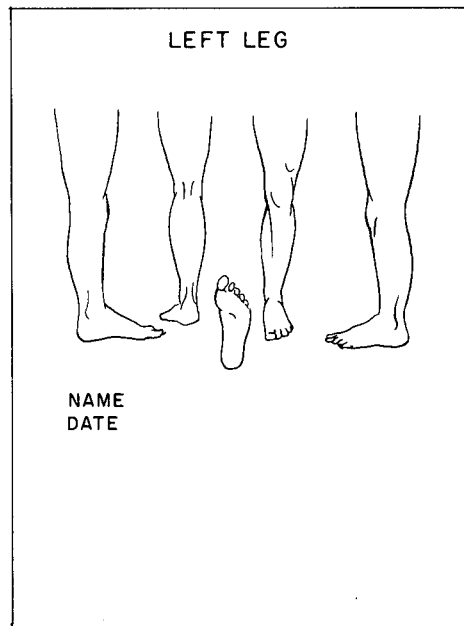
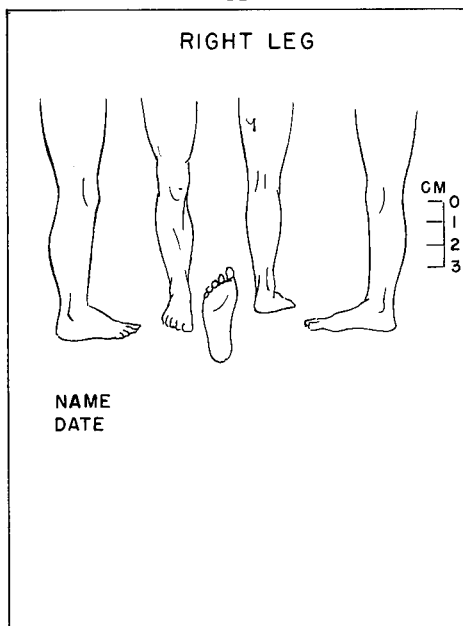
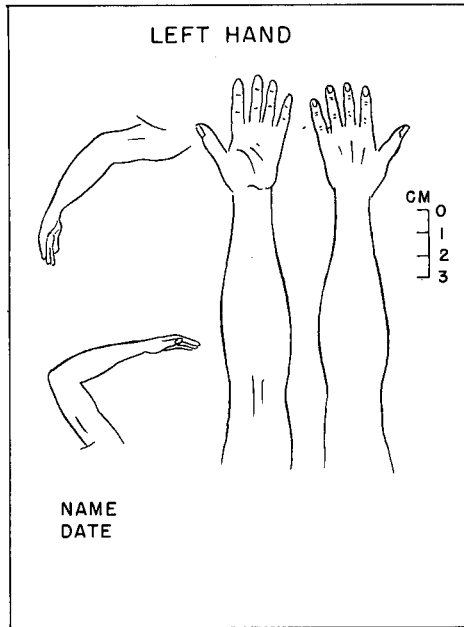
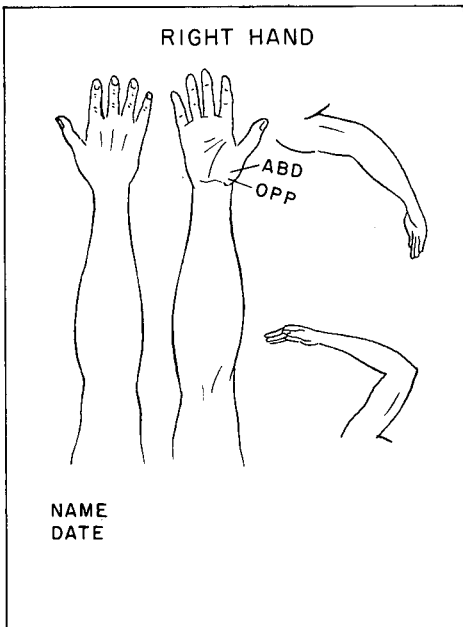

FIGURE 95.—Mimeographed forms for recording of motor and sensory examinations.

A. Right hand. B. Left hand. C. Right leg. D. Left leg.

NAME: _____
 ASN: _____
 DATE: _____
 EXAMINER: _____

ULNAR N.

Flex. carp. uln.

Flex. digit. prof. IV, V

Adduct. poll.

Abd. digit. V

Palm, dors. inteross.

A

NAME: _____
 ASN: _____
 DATE: _____
 EXAMINER: _____

RADIAL N.

Deltoid

Triceps long.

Triceps med., brev.

Brach. rad.

Ext. carp. rad. long, brev.

Ext. digit. comm.

Ext. carp. uln.

Abd. poll. long.

Ext. poll. long, brev.

B

NAME: _____
 ASN: _____
 DATE: _____
 EXAMINER: _____

MEDIAN N.

Flex. carp. rad.

Flex. indic. prof.

Abd. poll. brev.

Oppon. poll.

C

NAME: _____
 ASN: _____
 DATE: _____
 EXAMINER: _____

SCIATIC N.

Hamstrings

Gastrocnem.

Flex. digit.

Flex. hall.

Abd. digit. min.

Post tibial n.

Common peroneal n.

Lat. plantar n. (sens.)

Med. plantar n. (sens.)

D

NAME: _____
 ASN: _____
 DATE: _____
 EXAMINER: _____

COMMON PERONEAL N.

Superf. peroneal n.

Tib. ant.

Peron. long, brev.

Ext. dig. long.

Ext. hall. long.

Deep peroneal n.

E

FIGURE 96.—Forms for recording progressing regeneration of injured peripheral nerve. These forms were blocked on cardboard, on which the following directions were listed: Mark site of injury and state distance from injury to muscle examined in inches. Write date of first muscle action in appropriate space. Indicate whether method of examination was (1) voluntary contraction, (2) electrical stimulation on skin, or (3) bipolar intraneural electrical stimulation. A. Form for ulnar nerve. B. Form for radial nerve. C. Form for median nerve. D. Form for sciatic nerve. E. Form for common peroneal nerve.

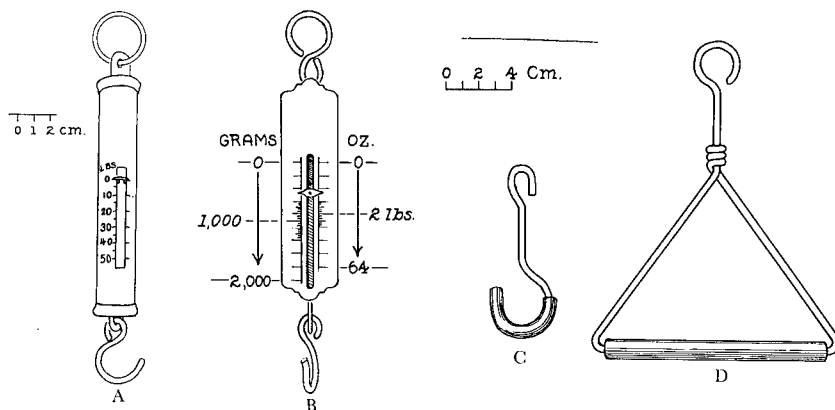

FIGURE 97.—Spring scales and appliances for measuring muscle strength.
See text for description.

used the technique in World War I, but no one seems to have followed his example. The method does not always test single muscles, but rather muscle groups active in a motion. The ability to resist the passive extension of a voluntarily contracted muscle group is determined by means of a spring scale and expressed in pounds.

The values so derived were recorded in the sensory form, either directly in pounds or computed in percentages of normal. Table 9 gives the *M* (computed mean) of the strength of various normal muscle groups participating in a motion, their *SD* (standard deviation), and their *SE* (standard error). The normal values were obtained from a hospital population which, as a group, did not show the fitness of combat soldiers. The random sample consisted of persons showing no nerve or muscle weakness and included studies on manual and clerical workers, as well as on both extremities of right-handed and left-handed individuals.

The reliability and limitations of the method were statistically evaluated by plotting its values, expressed in percent of the normal, against the voltage of the electromyogram on maximal nerve stimulation, also expressed in percent of the normal. A high degree of relationship was found ($r = +.75$ with an *SE* of 0.04). Ninety-four and a half percent of all points of the scatter diagram fell within the limits of ± 2 *SD*. The results of the method may be called reasonably reliable, reproducible and comparable.

Materials.—Material (fig. 97) for this test consisted of the following items:

1. A spring scale indicating up to 50 pounds and a smaller scale with a 64-ounce capacity for measuring the first appearance of strength in hand and finger muscles.

2. A wire about three-sixteenths inch thick and about 4 inches long, one end of which was bent to hook into a ring of the scale; the other end was bent into an open loop of about $1\frac{3}{4}$ inches in diameter and was covered with a rubber tube.

TABLE 9.—Average strength of motions of hospital population expressed in pounds (450 gm.)

Anatomical location and nerve	Motion	Mean (M)	Standard deviation of mean (SDM)	Standard error of mean (SEM)	Range for normals (M \pm 2 SD)
Upper extremity:					
Median nerve:					
Index finger	Flexion, end phalanx (flex. dig. prof.)	12.2	1.2	0.2	10-14½
Thumb	Flexion, end phalanx (flex. poll. long.)	12.4	1.0	.15	10½-14½
	Flexion, prox. phalanx (flex. poll. br.)	21.3	2.5	.25	16½-26½
	Volar abduction (abd. poll. brev.)	11.9	1.2	.3	9½-14½
	Opposition (opponens)	17.4	1.2	.3	15-20
Wrist	Flexion	30+			
Ulnar nerve:					
Little finger	Flexion, end phalanx (flex. dig. prof.)	12.2	1.2	.2	10-14½
	Abduction (abd. dig. V)	8.9	.6	.12	8-10
	Adduction (add. dig. V)	2.3	.6	.1	1-3½
Index finger	Abduction (inteross. I)	9.0	.8	.13	7½-10½
	Adduction	4.1	.4	.1	3½-5
Thumb	Adduction	10.4	1.0	.2	8½-12½
Radial nerve:					
Wrist	Extension	30+			
Fingers	Extension, prox. phalanx (ext. dig. com.)	11.8	1.4	.22	9-14½
Thumb	Extension, distal phalanx (ext. long.)	8.8	1.7	.17	4½-12
	Extension, proximal phalanx (ext. brev.)	13.4	2.1	.2	9-17½
	Radial abduction (abd. poll. long.)	11.9	1.2	.3	9½-14½
Lower extremity:					
Tibialis posterior nerve:					
Toes	Flexion	19.3	.2	.2	19-20
Foot	Flexion (plantar flexion)	40.4	1.9	.2	36½-44
	Inversion (tib. post.)	20.8	2.0	.2	17-25
Peroneal nerve:					
Toes	Extension	15.8	1.9	.2	12-19½
Foot	Extension (dorsiflexion; tib. ant.)	30.5	1.9	.2	27-34
	Everson (peron. long. and br.)	20.6	1.7	.2	17½-24

3. Wire of the same type formed into an isosceles triangle of 4-inch length, the base of which was padded with rubber; the opposite tip was bent to hook into the scale.

4. A thin metal plate about 4 inches long and 1 inch wide with a hole in one end for the scale. The plate was wrapped in tape to provide a good grip.

Technique.—The patient was informed of the principles of the method and was admonished energetically and repeatedly during the entire examination to apply all possible force in resisting the pull of the scale. Hand, fingers, or leg had to be fixed by the examiner in such a manner that the patient was prevented from pulling with muscle groups other than those under scrutiny. Figure 98 A, B, and C shows the procedure in testing the forearm, hand, or finger muscles. In the foot, plantar and dorsal flexion of foot and toes and eversion and inversion of the foot (fig. 98 D) were tested. This same method could be applied for measuring other muscle groups in the arm and leg.

It was important in this test to hold hand, fingers, and foot exactly as demonstrated and to exercise traction in the given direction. Patients developed, unconsciously, innumerable trick movements and learned to use auxiliary muscles. The positions of extremities, hook, and scale were so chosen as to exclude, as far as possible, undesirable errors, such as the contraction of the finger extensors in testing abduction of the index or little fingers. Nevertheless, inspection and palpation of the muscles or muscle groups under scrutiny were not omitted.

The duration of examination for each injured nerve was 25 minutes.

Recording.—Each figure which was secured was immediately noted in its proper space in the form. Figure 99 indicates the points at which the strength of each motion (adduction, abduction, opposition, and so forth) was inscribed. The results were recorded either directly in pounds or in percentages of the normal, depending on the purpose for which they were to be used. The large figure (M) (fig. 98 A, B, C, and D) was used to compute the percentage of deviation from the norm. The range (small figures, ± 2 SD) provided a general idea of what strength could be expected in a certain movement. The pounds given on figure 98 A, B, C, and D are slightly at variance with those of table 9; they are rounded to a quarter of a pound, in contrast to the calculated values of table 9.

The unit of measurement was noted on each patient's chart, with the date, name of patient, and examiner. Special remarks were sometimes useful, that the patient did or did not apply maximal force, for example, that he seemed to be in good or poor condition, or that it was a very hot day.

Figures 111, 116, 117, 118, 120, 122, and 124 are examples of gradual increase of muscle strength in injuries of the peripheral nerves, expressed in percentage of the normal. The measured distance from the site of the injury or suture to the muscle examined is given in inches (") in relation to

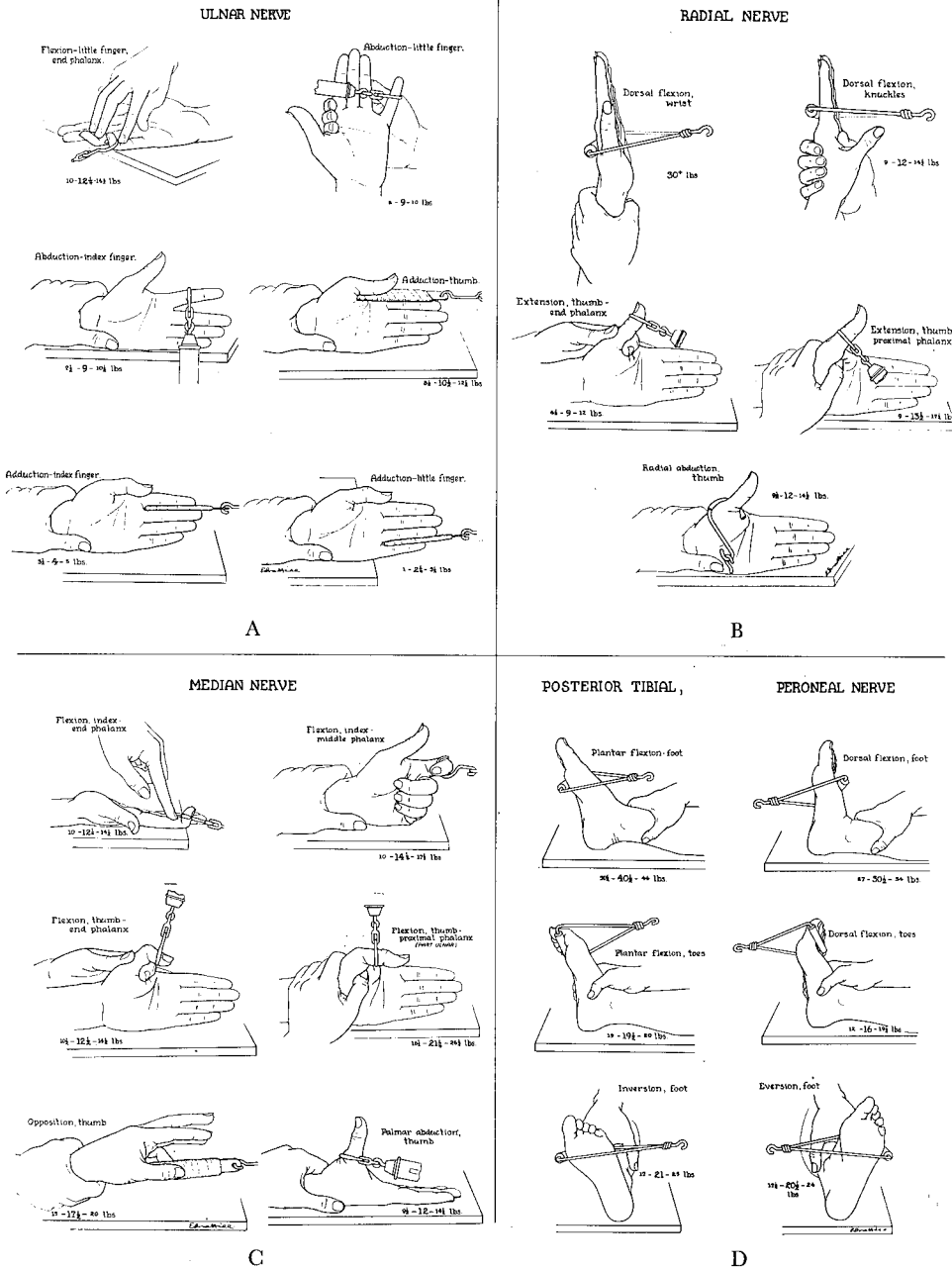

FIGURE 98.—(See opposite page for legends.)

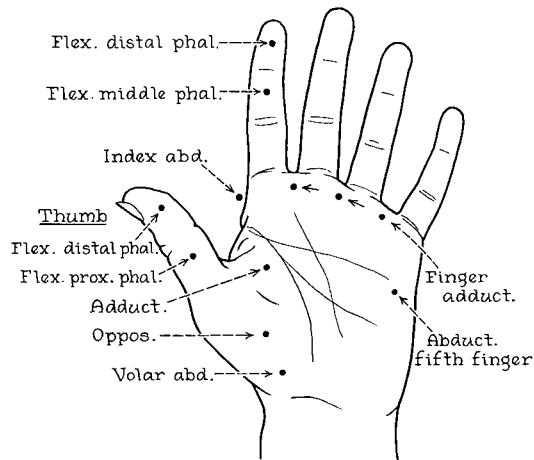

FIGURE 99.—Diagram indicating exact spots on sensory form on which measured strength of respective motions were recorded.

the time elapsed since injury or suture in months (m). The average growth rate of all nerves, including the initial phase, was found in over 1,000 patients to be 1.4 mm. per day or about one fifty-eighth inch per month.

NERVE BLOCK TO ELIMINATE SUPPLEMENTARY MOVEMENTS

Trick movements have already been mentioned as a source of erroneous interpretation of recovery from nerve injuries. True trick movements, as explained by Jones,⁴ are passive movements. They are brought about by tension on the paralyzed muscle by overaction of its antagonist, by recoil phenomena, or by the action of gravity. Such faulty methods of examination were carefully avoided.

Supplementary movements are performed by muscles so connected with joints or tendons that these structures are able to take over the action of the paralyzed muscle. In addition, there are true individual variations, as, for instance, in the innervation of the thenar and flexor profundus muscles by ulnar and median nerves. These movements are not sufficiently stressed

⁴ Jones, Robert (editor): *Orthopaedic Surgery of Injuries*. London: H. Frowde, 1921.

FIGURE 98.—Standard position, fixation of parts, and direction of traction for measuring strength of various characteristic movements. The technique was devised to prevent trick movements and minimize interference with supplementary movements. The presence or absence of contraction of the corresponding muscles had to be verified by inspection and palpation. The large figures on the form indicate the mean strength of the hospital population surveyed and the smaller figures the range (± 2 SD) expressed in pounds (450 gm.). A. Technique for testing ulnar nerve. B. Technique for testing radial nerve. C. Technique for testing median nerve. D. Technique for testing posterior tibial and peroneal nerves.

in many textbooks of anatomy and neurology. Well-known twigs—sometimes good sized, sometimes rudimentary—connect the two nerves on the forearm. An extensive ulnar nerve overlap into the territory of the median will greatly benefit a person with median paralysis but harm one with ulnar paralysis.

In view of these facts, a block of the motor fibers of one or more adjacent nerves was found to be the only safe way to obtain a correct diagnosis. One patient, an officer, was observed with a complete interruption (later confirmed) of the ulnar nerve at the elbow. His only motor deficit was an inability to flex the tip of the little finger. He was not willing to accept the diagnosis and the recommended suture of the nerve until block of the median nerve convinced him of the loss of ulnar function.

This method was used before the war by a number of observers, including J. C. White in his investigation of peripheral vascular disorders and Woollard in cases of sensory dissociation. Highet⁵ availed himself of the method systematically during World War II.

Materials.—The materials employed included the following items:

1. Hypodermic needles (No. 25).
2. Varnish M 473 (Sterling Varnish Co., Haysville, Pa.).
3. An electric stimulator.
4. A plate electrode (indifferent electrode).
5. Wires and alligator clips.

The needles were thoroughly cleaned, dipped into the varnish, and dried hanging, with the tips downward, to obtain an even coating. They were baked at a temperature of not less than 135° C. (275° F.) for 4 to 6 hours. The points of the needles were carefully pared with a sharp knife to avoid chipping. The needles were sterilized by boiling or in alcohol.

Technique.—The needle was attached to a 5-cc. syringe filled with 2-per cent procaine solution, to which adrenalin had been added (1:50,000). One pole of the stimulator was fastened on the hub of the needle by means of an alligator clip. The other terminal went to the indifferent electrode. The needle was inserted into the nerve to be anesthetized, the correct position being suggested by the motor and sensory effects of electrical stimulation. Injection of 2 to 10 cc. of the procaine solution was necessary to produce complete motor and sensory paralysis, including vasodilatation and anhydrosis, in 10 to 15 minutes. The block lasted for 2 to 4 hours. The method could be used concurrently with bipolar intraneural stimulation of the injured nerve and with a sweat test.

The duration of this test was 45 to 60 minutes.

Opposition of the thumb in a median paralysis, if prevented by anesthesia of the ulnar nerve, was not considered suggestive of regeneration of the median nerve.

⁵ Highet, W. B.: Procaine Nerve Block in the Investigation of Peripheral Nerve Injuries. *J. Neurol. & Psychiat.* 5: 101-116, July-October 1942.

HANDPRINTS AND FOOTPRINTS

The use of handprints and footprints was introduced into neurology by Pollock,⁶ in 1920, to record muscle atrophies and their gradual improvement as well as trophic disturbances of the skin.

Materials.—The materials used in this test included the following:

1. A thick glass plate, or a sheet metal plate nailed on a board, 6 inches wide and 8 inches long.
2. A squeegee roller 5 inches wide, as used for photographic printwork.
3. Printer's ink which comes conveniently in tubes for fingerprinting or in bottles for mimeographing.
4. Mimeograph paper or any similar absorbing paper which is not glossy.

Technique.—The palm or the sole was scrubbed and cleaned with 70 percent alcohol and dried with a hair drier. A drop of printer's ink was placed on the glass or metal plate and distributed with the squeegee until the plate was evenly inked. The squeegee was rolled over the palm and fingers or the sole and toes. It was advisable to have an even, thick film of ink over the entire surface at once. It was difficult to correct incomplete inking without collecting stain at the seams, which reproduced as thick lines. Experience taught how much ink was best for good prints.

The mimeograph paper was placed flat on a wrinkle-free, hard surface. The hand, with thumb and fingers slightly separated, was placed flat, with the arm strictly vertical, on the paper and was carefully pressed against it. Each digit was cautiously rolled as for fingerprints. Here, again, experience told the degree of pressure necessary to produce a good skin pattern without distorting the picture.

The inked sole was similarly placed flat on the paper. Weight was put on the foot, and the toes were slightly rolled over the paper. Foot and toes were lifted simultaneously from the paper.

Two or three prints of decreasing density could be made with one inking, to be inserted into the copies of the chart. The signed prints were covered with onion sheet paper. The ink was easily removed from the skin by scrubbing with green soap and hot water. The ink plate was cleaned every evening and freshly inked before use. Because of its changing quality, each batch of ink required a few test prints.

The duration of the tests was 10 minutes.

Results.—Atrophy of muscles and clawing of fingers and toes were clearly seen in the prints obtained by this technique. The gradual return to normal could be followed by comparison with subsequent prints (figs. 111, 114, 115, 116 B, and 117 B). Figures 100 and 101 indicate the site of atrophic muscles in paralysis of the corresponding nerves. With some experience, the diagnosis of a median, ulnar, or combined nerve lesion could be made from the print.

⁶ Pollock, L. J.: Hand and Foot Prints as Records in Lesions of the Peripheral Nerves. J.A.M.A. 74: 943-944, 3 Apr. 1920.

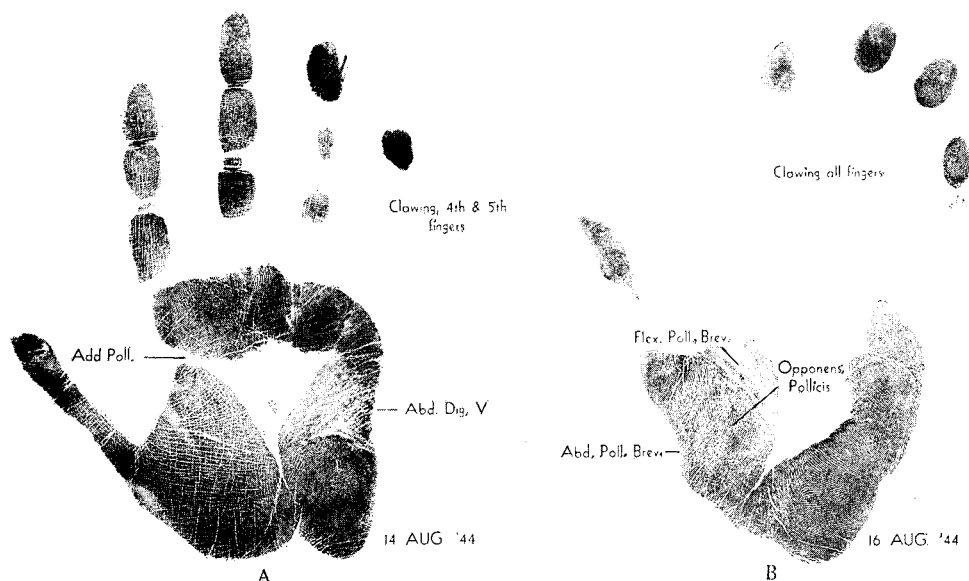

FIGURE 100.—Handprints indicating paralysis of peripheral nerves of arm. A. Print of left hand of patient with mild ulnar paralysis. Note clawing of fourth and fifth fingers and mild atrophy of abductor pollicis and of concavity of abductor digiti V, which is normally convex. B. Print of right hand of patient with complete median paralysis. The abductor pollicis shows a concave surface. The opponens pollicis is flattened. The flexor pollicis brevis shows a defect in its median portion. All fingers are clawed, the fourth and fifth chiefly because of ankylosis.

The prints in radial and peroneal nerve paralysis were not characteristic enough to be made routinely. The loss of the intrinsic foot muscles was sometimes quite marked (fig. 102). The trophic changes of the sole in tibial nerve injuries and their recovery could be easily demonstrated and recorded (fig. 103).

ELECTRODIAGNOSIS

It was observed that the most careful measurements of motor function were often inadequate in two types of patients: (1) Those with recently neurotized muscles who had not yet learned their voluntary use and (2) those in whom overlap injuries of a muscle gave a false notion of regeneration through the nerve that normally supplies it. In both these instances, the presence or absence of function of the nerve in question could be promptly established by bipolar intraneural stimulation.

SENSIBILITY TESTS

Four main types of sensitivity were differentiated, as follows: (1) Pain and temperature sensation; (2) deep pressure, joint, and position sense; (3) superficial pressure (touch); and (4) vibratory sense.



FIGURE 101.—Handprints of patient with complete paralysis of left ulnar and median nerves. A. Print of left hand showing severe atrophy of all intrinsic hand muscles. B. Print of normal right hand of same patient.

Experience showed that not all modalities of sensation are equally important for judging lesions of the peripheral nerves. Temperature sensation ran fairly parallel with pain sensation. Quantitative temperature measurements did not deliver sufficient additional information to warrant the complicated apparatus required. Examinations of joint and position sense were reserved for special cases. Vibration spread too widely over the skin to normal parts to give reliable results in peripheral nerve injury.

Pain sensation to pinprick and perception of superficial pressure were the modalities of sensation whose exact measurement gave the most useful data. The question of the interpretation of pain response in deep pressure to the terminal phalanges is still controversial. The isolated return of pain sensation did not appear to afford positive evidence of regeneration.

A pin and a wisp of cotton wool were all that were needed for the first orientation and for outlining the area of complete loss of sensation. This field, if examined soon after complete interruption of a nerve, has been called the maximal area of anesthesia. It includes the black and the dotted areas of figures 104 and 105.

Within a few weeks or months, the anesthetic field gradually shrank from its periphery toward the center until the dotted area eventually regained normal sensation. This area is called the overlap area of the adjacent skin nerves. It was important to remember that recovery of



FIGURE 102.—Footprints of patient with contusion of left tibial and peroneal nerves caused by bullet wound through thigh 15 July 1944. A. Print taken 29 September 1944, showing gross trophic disturbances of sole of foot. Note scar across heel. B. Print taken 7 March 1945, when motor recovery was full and sensory recovery 50 percent complete. Note beginning of transverse arch and partial return of normal skin pattern.

sensation in the overlap area was not a sign of regeneration in the interrupted nerve.

When the overlap area has regained full pain and touch sensation, the black areas may remain void of sensation and mark the area which is exclusively innervated by the interrupted nerve. This area, the so-called autonomous area or region of isolated sensory supply of a nerve, should not be confused with the extension of the residual sensibility. This term, which was used by Sherrington for the territory of a spinal root after transection or full anesthesia of its two or three adjacent upper and lower roots, has been applied to the sensitive area of a peripheral nerve after anesthesia of its neighbors. This area, in the order of magnitude, is the maximal functional field of a sensory nerve, including its overlap area into the adjacent skin nerves. The isolated sensory supply (autonomous area), on the contrary, represents the smallest sensory field. This area does not, in most cases, regain sensation until the injured nerve has regrown into the skin and made contact with its end organs.

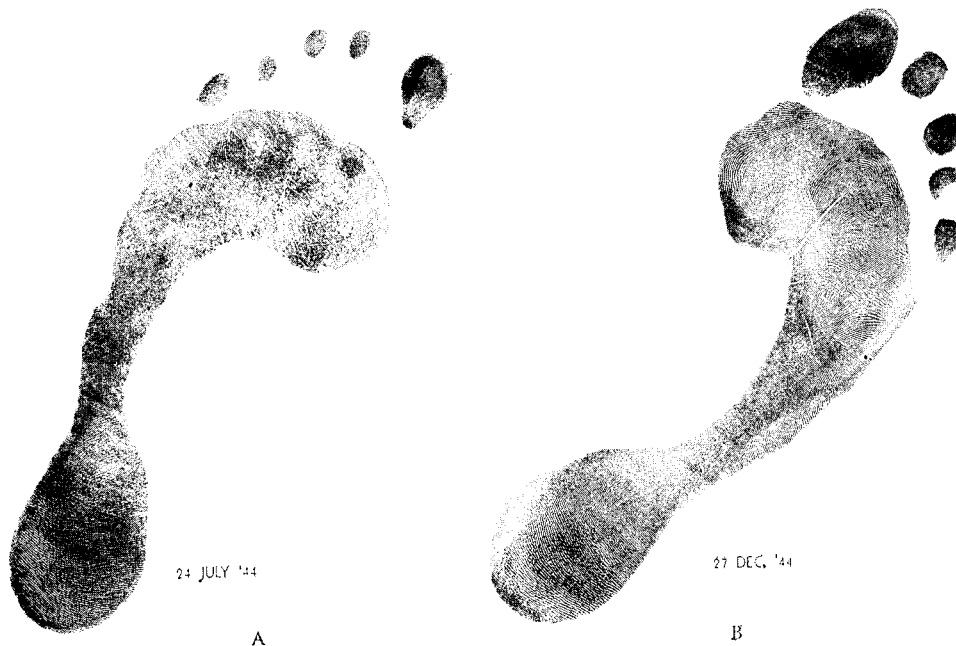

FIGURE 103.—Footprints of patient with interruption of left tibial nerve 15 inches above sole of foot 16 March 1944. A. Print of left foot showing clawing of toes, atrophy of intrinsic muscles of foot, and loss of skin pattern 24 July 1944. B. Print of normal right foot of same patient.

Some characteristics of decreased sensitivity might be explained by a combination of physiologic and anatomic conditions. The function of a sensory nerve might be so impaired that its threshold of irritability was increased. A stronger stimulus was needed to produce a sensation. The term "hypesthesia" was used for decrease of touch sensation and the term "hypalgesia" for decrease of pain sensation.

On the other hand, only a certain number of nerve fibers might have been injured or regenerated to their end organs in the skin. The end organs which were present might have a normal threshold, but only a percentage of the normal number of pain or touch points could be found. The terms "penesthesia" and "penalgesia" were used for this condition, to imply scarcity of end organs.

The importance of determining the number of pain points and of touch points, or both, under certain conditions is best exemplified in a specific case (fig. 106). The threshold for touch and pain sensation in a patient with radial paralysis (8 gm.) had not improved during a period of 3 months. The conclusion might have been drawn that regeneration had not progressed and that the nerve was possibly scarred and should be explored. Determination of the number of end points, however, showed that a great number of nerve fibers had arrived in the skin since the last examination. That

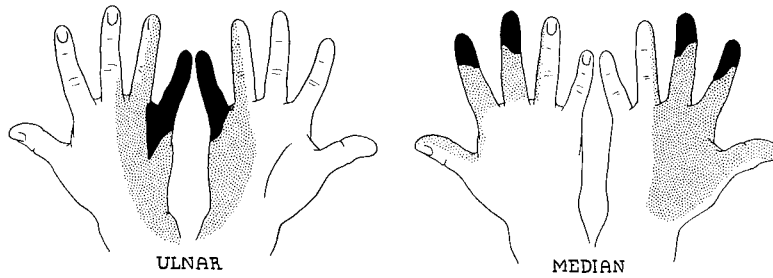

FIGURE 104.—Diagrams showing areas of autonomous or isolated sensory supply of ulnar and median nerves (black) and of fields of overlap from adjacent nerves (dotted). Shrinkage of anesthesia in dotted field does not indicate regeneration of injured nerve.

regeneration was progressing on schedule was borne out by later developments.

Pinprick is felt painfully only on stimulation of the end point of a pain-sensitive nerve fiber. Its threshold was determined by measuring, in grams, the pressure under which a pin had to be pressed against the skin to produce soreness.

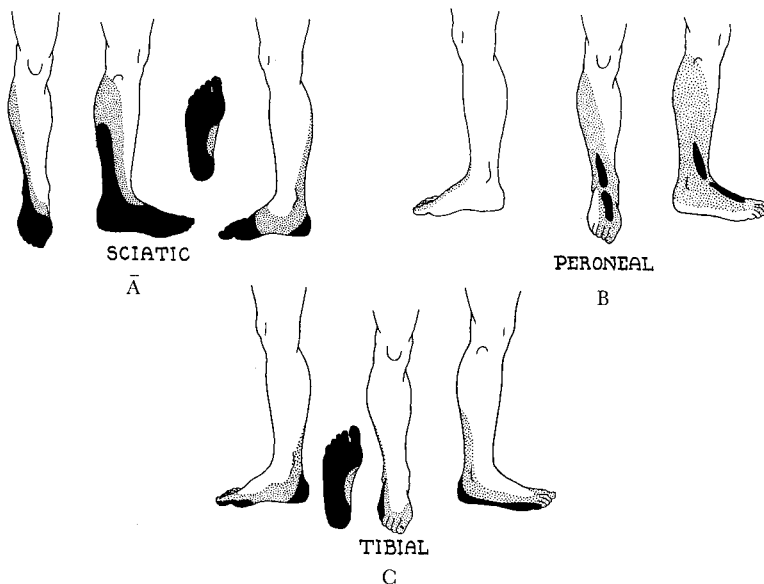

FIGURE 105.—Diagrams of areas of autonomous or isolated sensory supply of sciatic, peroneal, and tibial nerves (black) and of fields of overlap from adjacent nerves (dotted). Shrinkage of anesthesia in dotted field does not indicate regeneration of injured nerve. A. Sciatic nerve. B. Peroneal nerve. C. Tibial nerve.

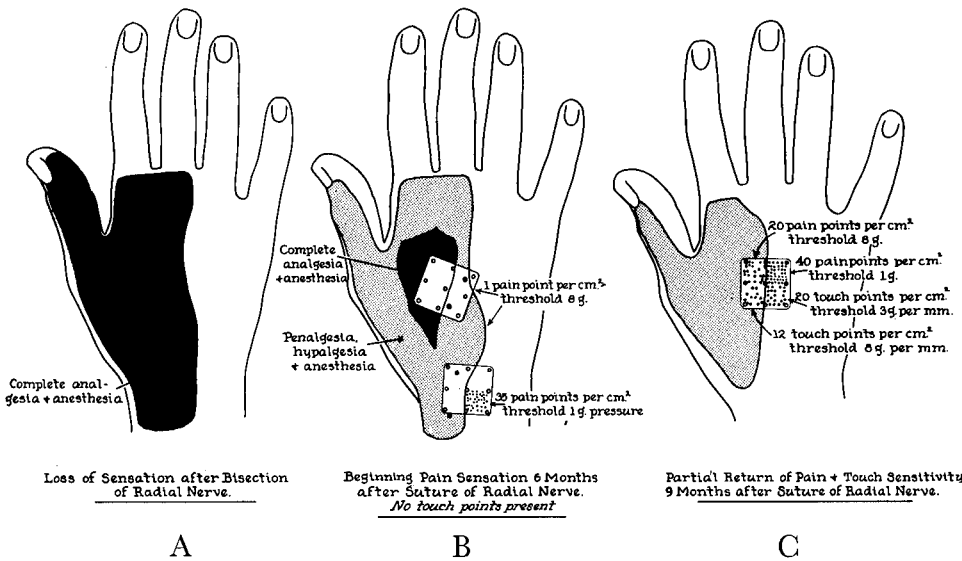

FIGURE 106.—Diagrams showing quantitative estimation of pain and touch points and their threshold after injury of radial nerve. A. Complete loss of sensation in radial distribution after bisection of radial nerve. B. Beginning return of pain and touch sensation with 8-gm. threshold 6 months after nerve suture. C. Partial return of pain and touch sensitivity 9 months after nerve suture. Although the threshold shows no further improvement 3 months after the last test, as shown in B, the number of points has increased from 1/cm.² to 20 and 12 respectively, indicating good nerve regeneration.

This is not the situation with the end organs for touch.⁷ Touch, which really means superficial pressure, produces a slight indentation of the skin which becomes deeper with increased pressure. As this happens, a greater number of end organs become involved and stimulated. The threshold is expressed in terms of the tensile strength of the von Frey's hair which just produces sensation. As a rule, therefore, touch sensitivity is expressed in grams per millimeter.

The average threshold of pain sensation is one-half gram and of touch sensation 1 gram per millimeter. There is little variation of threshold in the various parts of the extremities.

The normal density of pain and touch points varies a great deal in various parts of the body and undergoes great variations during life. End organs are normally grouped in clusters, and numerous minimal lesions of the skin in the course of life decrease the number of end organs and may leave parts completely bare. Most neurologists have agreed to calling 50 pain end organs and 30 touch points per square centimeter a normal number.

⁷ There are two types of touch end organs: (1) The basket-shaped nerve endings around the root of each hair and (2) Meissner's end organs in hair-free parts of the skin. In hair-clad portions of the skin, the number of touch points is about equivalent to the number of hairs within the same field.

This is far below the actual number of pain points, but there are practical limitations to mapping out a larger number.

SENSORY EXAMINATIONS

Each sensory examination begins with the question of what type of sensation, if any, the patient observes in the area of the injured nerve. Numbness means absence of touch sensation in the skin and continues usually for a while after pain sensation has returned. The term "paresthesia" comprises many abnormal sensations and requires specification.

QUALITATIVE DETERMINATION OF SEQUENCE OF RETURNING SENSORY FUNCTION

Tinel's Sign

Tinel first drew attention to the fact that the amyelinic nerve fibers at the tip of a regenerating nerve are sensitive to gentle compression. The sensation is that of formication and is usually likened to electricity by the patient. It is not local but is projected into the skin distribution of the compressed nerve.

This tingling sensation is not to be confused with pressure pain, which is confined to the place of nerve compression or its immediate neighborhood. The sensation is often elicited by compression of adjacent muscles and is sometimes even more marked in them.

Tinel's sign, if present, is of great significance for the prognosis of nerve regeneration, but its value depends on exact performance of the test. Both Tinel and Woodhall stressed the importance of strict adherence to the original definition of the phenomenon.

Three observations have to be secured before any conclusion can be drawn, as follows:

1. From 4 to 6 weeks after partial injury or suture of a nerve, gentle compression of its distal portion, about 1 or 2 inches below the lesion, must produce a tingling sensation in the peripheral distribution of the compressed nerve confined to its anatomic distribution.
2. This trigger point must become insensitive to pressure a few weeks later.
3. The sensitive spot must travel down the nerve with a velocity of about 1.5 inches a month.

This sequence of events was found to be characteristic of nerve regeneration, but it indicated nothing about its degree. The absence of formication on nerve compression, as well as failure of the trigger point to migrate down the nerve, suggested a poor prognosis. These findings indicated that the nerve was completely interrupted or that its fibers had not passed the suture line or that they had met an obstacle and had not progressed beyond it.

Tinel's sign was therefore regarded as of primary importance in the evaluation of a nerve injury. It had a negative value in demonstrating when the nerve was interrupted or had not regenerated or when a suture was a failure.

QUALITATIVE METHODS OF MAPPING OUT AREAS OF IMPAIRED SENSATION

Dragging a pin over the skin from the analgesic or hypalgesic area toward the intact skin was found to be the simplest way of outlining an area of lost or decreased pain sensation.

Pain sensation to unqualified pinpricks depended chiefly on sharpness and thinness of the needle used and the changing degree of pricking. Pollock suggested, to prevent the latter change, that the pin be inserted into a 5-cc. or 10-cc. syringe and be weighted down by means of the piston.

Gentle touch with a wisp of cotton wool was used successfully over hairless parts to determine qualitatively the perception of superficial pressure (touch), but it gave erroneous results over hair-clad portions. It was inadvisable to draw a wisp of cotton or a hair over the skin; this practice led to summation phenomena and wrong conclusions. Simultaneous stimulation of skin and deep sense organs was done only with a camel's-hair brush. The borderline between denervated and intact skin was marked with a red pencil.

Recording.—It was found more difficult than is usually realized to transfer correctly the outline of a determined skin area to a blank. For routine clinical purposes, an approximate reproduction on the form was sufficient. If greater exactness was desired, the skin drawing could be copied through an onionskin sheet of paper, or, better, a photographic record, could be made.

QUANTITATIVE DETERMINATION OF PAIN SENSATION

Head's spring algometer (fig. 107) is a handy, easily manufactured instrument sufficiently exact to determine the threshold of pain. It was found practical to have one instrument to measure prick under a pressure of 2 to 10 gm. (fig. 107 A) and another to measure it under a pressure of 10 to 40 gm. (fig. 107 B). Returning superficial pain sensation might need values even up to 60 gm.

Materials.—Each of these instruments consists of a thin metal tube 10.5 cm. long and 6.5 mm. in the external diameter. Tube A (fig. 14 A) is closed at the top, and the tip is screwed on. Tube B (fig. 14 B) is closed at the tip and the top is screwed on. Tube A contains a thin metal rod ending in a moderately thin needle. A small crossbar at the upper end of the rod supports the needle at the blind end of the tube; another bar, at the lower end, limits the protrusion of the needle from the tube. A fine spring scale, soldered to the crossbar at the upper end of the rod, connects at its lower end through a slot with a collar surrounding the tube. The spring is so cal-

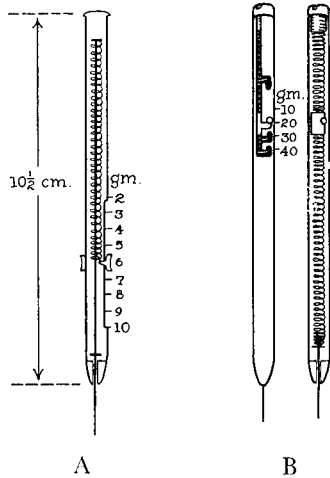

FIGURE 107.—Structure of Head's algometer. A. Algometer for prick under pressure of 2 to 10 gm. B. Algometer for prick under pressure of 10 to 40 gm.

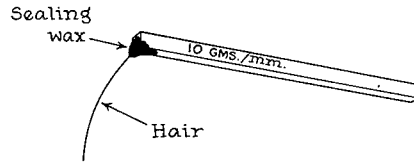

FIGURE 108.—Graduated hair after von Frey for measuring threshold of sensibility to touch (superficial pressure).

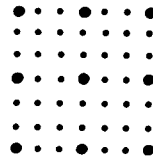

FIGURE 109.—Pattern of rubber stamp used for estimation of number of pain and touch points per square centimeter. Each side of square measures 2 cm.

ibrated that the point of the needle, when applied vertically, bears only its own weight. When the collar is slid down, increased pressure is exerted on the needle. The degrees of pressure can be measured in grams by turning the scales.

Tube B contains a longer and coarser spring with a crossbar, which connects with the needle at the lower end only. A collar which glides inside the tube is fixed to the spring at such a point that it exercises a pressure of 10 gm. when the upper end of the spring presses against the screw, closing the tube, so as to bear only its own weight. A small button at the outer circumference of the collar protrudes through a slot. This button can be moved downward and fixed on 1 of 3 openings which are so placed that they exert a pressure of 20, 30, and 40 gm., respectively.

Technique.—The patient was instructed to observe pain or soreness, not degrees of sharpness, and to disregard the touch sensation accompanying the prick. Pain had to be all or nothing. If the patient had to think over what he felt, it was usually not pain. A preliminary test over a pain sensitive area best explained what to expect. The pin was placed vertically on the skin. The threshold was determined by gradually increasing the pressure until further increase did not augment the number of pain points in a given area.

The duration of this test was 20 minutes.

Recording.—The measured grams of pressure were noted with a red pencil in the outlined area or were surrounded with a red square. The territory in which prick under a load of 40 gm. was not felt as pain was considered analgesic and painted red.

QUANTITATIVE DETERMINATION OF SUPERFICIAL PRESSURE (TOUCH)

Materials.—Materials required for this test were a set of von Frey's hairs, prepared in the following way:

A great number of human hairs and horsehairs, about 1 to 1½ inches long were collected. The force (f) exerted by bending the hairs was measured in milligrams by turning the scales. The force in the sets used at Cushing General Hospital varied between 45 mg. and 1,800 mg. Hairs of equal force were grouped together.

The next step consisted in measuring the length of the two axes of the elliptic diameter of the hairs at their thick ends, which could be done in one one-thousandth of a millimeter (μ) with a thin slice of the hair. If the two axes of the ellipse were called a and b , the radius of a circle of equal size was $r = \sqrt{a \times b}$. This radius varied in the sets used in these studies from 0.045 to 0.090 mm. The force (f) of the hair measured in milligrams, divided by r (radius) expressed in millimeters $\frac{f}{\sqrt{a \times b}}$ gave the tension of the hair in grams per millimeter.

A complete test set after von Frey contained hairs of 1, 2, 3, 4, 5, 6, 8, 10, 15, and 20 gm./mm. tension. Deep sense organs might respond to hairs of 8–20 gm./mm. when cutaneous sensitivity was absent. The hairs were fixed with sealing wax to a piece of hardwood, the size of a kitchen match, and their tension value was noted on the handle (fig. 108). The handles were placed on a rack, which kept the hairs free from any contact, and the set was protected against humidity in a tightly closed box.

Technique.—Examinations were made in a quiet room with the patient seated comfortably and relaxed. The temperature was kept moderate because sweating as well as shivering impairs the accuracy of perception. The patient was instructed to say "Touch" whenever he felt a touch. No questions were asked. A short demonstration over the intact skin preceded the examination. During the examination, the patient kept his eyes closed.

Sixteen contacts of the skin were made per minute, following Head's suggestion, in irregular time intervals to avoid rhythmic answers and to detect the imaginary touch sensations so common in hypesthetic areas. The test was usually begun with the strongest hair of 20 gm./mm. and was not continued if this touch was not felt. If it was felt, the examiner then used the finest hair, of 1 gm. tension, and jumped rapidly to 3, 5, 8, 10, and 15 gm./mm. until the number of touch points was not increased further by use of a stronger hair. The examination was kept as short as possible because the test is trying and attention rapidly fails. Occasional touches over an area of intact skin checked the patient's attention.

The duration of the test was 20 minutes.

Recording.—The measured tension was noted with blue pencil in the outlined area of hypesthesia or was surrounded by a blue diamond. The ter-

ritory in which superficial pressure with the hair of 20 gm./mm. tension was not felt was considered anesthetic and painted blue (figs. 111 A, 113, 116 A, 117 A, 118, and 124). Completely analgesic and anesthetic areas were blacked out.

ESTIMATION OF NUMBER OF PAIN AND TOUCH POINTS

Materials.—A rubber stamp was prepared, outlining a square whose sides measured 2 cm. The borders of each centimeter were marked by thick dots. Each square centimeter was subdivided by small dots which served as landmarks only (fig. 109). By touching or pricking each dot and interval, it was easy to map out accurately 49 points per square centimeter.

An area of not less than 2 square centimeters was investigated because of the normal tendency to grouping of touch and pain points and because of their frequent loss following minimal skin lesions and the ensuing error.

Technique.—After delineation of the hypesthetic area, the inked rubber stamp was so placed on the skin that half of it lay within the hypesthetic field and the other half in the normal control area (fig. 106). The threshold was measured as described. The landmarks on the upper border of each centimeter were followed with pin or hair from left to right, each being touched seven times serially. To avoid adaptation, the examiner then went on to the lowest row of the same centimeter from right to left, continuing in zigzag movements until a square centimeter was mapped out. The other square centimeters were examined in the same way.

This method of examination was found to be the only exact one, because it precluded the possibility of touching the same sensitive points several times while bypassing insensitive ones. It was, however, time consuming and tiring and was therefore reserved for special studies.

The duration of the full test was 1 hour.

A rapid simplified survey of the number of pain and touch points could be obtained by touching the skin at random within the area of decreased sensitivity with the predetermined pin or hair 50 subsequent times. The patient was asked to register each sensation. The answers were tallied; a correct answer was marked by a slant, failure by a zero, and hallucinatory answers by a broken stroke. The relation of correct to missed answers, possible hallucinatory ones being disregarded, gave the percentage of points present directly. The method was inexact from a physiologic point of view but gave an approximate idea for clinical purposes.

The duration of the simple test was 15 minutes.

Recording.—The patient's hand was placed on a sheet of paper, and its contour was outlined. A print was made with the rubber stamp in the same position on the skin. The places of positive answers were marked in the corresponding spot on the paper (fig. 106). Pain points were marked in red, touch points in blue.

NERVE BLOCK TO ELIMINATE OVERLAP SENSATION

If it was doubtful whether an injured nerve had itself regenerated or its sensitivity had been restored by fibers of the adjacent skin nerves, it was helpful to anesthetize the fibers, as already described. If the original field remained sensitive, the conclusion was that the interrupted nerve had reached its skin distribution. Block of sensory nerves abolished, at the same time, sweating in their skin distribution. The combined anesthesia and anhydrosis following nerve block were often helpful in the frequent instances of an unusually large overlap in one of the hand nerves. It might be important to find out whether return of sensitivity was caused by shrinking in the overlap area or through regeneration, or whether an unusually small area should be interpreted as an individual variation or as the consequence of a partial nerve lesion.

In this test, it was necessary to copy the original outline of the anesthetic region through onionskin paper, or better, to photograph it.

LOCALIZATION OF RETURNING SENSATION

In the beginning of returning sensation, localization is not yet possible or may be incorrect or may show the phenomenon of split sensation. This means that a sensation is felt simultaneously at the point of touch and at another point or that it travels from the original point to a second one. This phenomenon is a sign of returning function.

Technique.—The extremity to be examined was hidden from the patient by a screen. The corresponding extremity of a helper was placed on the other side of the screen, in view of the patient, in the same position as the arm or leg to be tested. The patient was instructed to indicate with his index finger on the helper's limb the point at which he felt the touch on his own body. If the sensation radiated from the original point to another area, or if it appeared at two points simultaneously, he was asked to follow with his finger the course of the sensation.

The duration of the test was 30 minutes.

Recording.—The point touched was marked in black on the sensory form and the place to which it was projected was marked in red. In the case of split sensitivity, an arrow was run from the touched spot to the area of point of radiation.

COMPASS TEST (SPECIAL DISCRIMINATION TEST, TWO-POINT TEST)

The power of discriminating two points touched simultaneously or successively does not depend directly on the shortest distance between them. It is rather a judgment, predicated upon the interference of several impulses arriving in the cortex in very short intervals and integrated into peaks and

valleys of cortical activity. The distance of these peaks from one another or their frequency in the time unit is considered the determining factor of spatial discrimination. In reality, therefore, two-point discrimination is a frequency discrimination in the brain wave pattern.

Materials.—A pair of compasses was used in this test, as the name indicates. Head used a carpenter's compass, the legs of which were ground down until they had lost their sharpness. A minimal droplet of solder was sometimes affixed to the legs, but a piece of cork over the points was not a practical solution. Commercial esthesiometers are manufactured with blunt ivory points and have the advantage of a fine measuring scale and vernier, but an ordinary slide gage with a vernier whose jaws had been rounded was usually available and was easy to handle.

Technique.—All measurements were made in the longitudinal axis of the extremities. The following tabulation gives an approximate idea of the normal distance of two touch points in a given area as determined by Weber and confirmed by von Frey:

Skin region:	<i>Millimeters</i>	Skin region—Continued	<i>Millimeters</i>
Tip of tongue	1.1	Cheek	11.3
Volar surface of finger pulp	2.3	Dorsum of basal phalanx	15.8
Vola of middle phalanx	4.5	Lower part of forehead	22.5
Dorsum of finger and phalanx ..	6.8	Back of hand	31.5
Tip of nose	6.8	Forearm	40.5
Vola capit. ossis metacarpalia ..	6.8	Lower leg	40.5
Tip of toe	11.3	Back of foot	40.5
Dorsum of middle phalanx	11.3	Upper arm (middle)	67.5
Vola of hand	11.3	Thigh (middle)	67.5

This distance was selected for the first test. If the two points could not be felt clearly as separate units, the distance was gradually enlarged until threshold was obtained. With this distance, sometimes 2 points (and sometimes only 1) were applied to the area to be tested in irregular intervals but in such a sequence that the patient was touched 10 times with 1, and 10 times with 2 points.

The duration of this test was 30 minutes.

Recordings.—Sometimes only the measured distance was noted over the standard value in the examined part of the body, for instance $\frac{5}{1.5 \text{ cm.}}$. At other

times, McDougall's method of sampling was used. A correct answer was marked by a slant, placed above the line when one point was touched, below the line when two were touched. An error was marked with a cross placed above the dividing line when one point was called two and below it when two points were called one. The answers, whether right or wrong, were arranged in strict sequence above and below the horizontal line. Such a record in a field with a normal spatial discrimination distance of 1.5 cm. is shown before the return of two-point discrimination:

1.5 cm. $\frac{1}{2}$ $\frac{///}{XX}$ $\frac{//}{X}$ $\frac{/}{XXX}$ $\frac{//X/}{XXXX}$ or short $\frac{1.5 \text{ cm.}}{2}$ $\frac{1}{2}$ $\frac{9 \text{ R.}}{2}$ $\frac{1 \text{ W.}}{10 \text{ W.}}$

This record changed with gradually returning spatial discrimination to:

1.5 cm. $\frac{1}{2}$ $\frac{///}{//X}$ $\frac{//}{/X/}$ $\frac{//X}{/X}$ $\frac{//}{XX}$ or 1.5 cm. $\frac{1}{2}$ $\frac{9 R. 1 W.}{5 R. 5 W.}$

In other words, there was no recovery of the two-point discrimination in the first record and only 50 percent recovery in the second.

SWEAT TESTS

The skin area of an interrupted peripheral nerve does not sweat. The autonomic (cholinergic) sweat fibers run along with the sensory branch of the nerves. The area of lost or decreased sweating is similar to, though not completely identical with, that of diminished sensitivity. The sweat test could be used, therefore, as an objective means of verifying the patient's statement about hypesthetic or anesthetic regions or to demonstrate them if the patient was unconscious or otherwise unable to cooperate.

Sweat Tests of Hands

The simplest and cleanest method of recording sweating, though it is limited to the palm of the hand, was described by Silverman and Powell.⁸ It is based on the fact that ferric chloride forms a black-blue ink with tannic acid in the presence of sweat.

Materials.—Materials for this test included the following items:

1. Five-percent aqueous solution of tannic acid.
2. USP tincture ferric chloride, diluted 1:3 with alcohol (25 percent), to be kept in a tightly closed brown bottle.

Technique.—The tannic acid solution was poured into a glass or enamel (photographic) tray large enough to hold letter-sized paper. Ordinary mimeograph paper was soaked in the solution for 3 minutes and then allowed to dry. The patient's palm was cleaned with alcohol and dried with a blower or fan. It was painted with the ferric chloride by means of an applicator and again dried.

One cubic centimeter of furtrethonium iodide (Furmethide iodide) (containing 5 mg.) was injected intramuscularly. Profuse sweating began within 3 to 5 minutes. The patient placed his wrist, flexed 90°, against the edge of a table, the forearm hanging straight down. This position permitted maximal flattening of the hand. The examiner pressed the hand firmly down on the tannic acid paper and held it in position for about 3 minutes. The hand was then lifted straight upward, to avoid smearing. If the first print was too heavy, the hand was placed at once upon another sheet of treated paper. The correct degree of printing was found after some experience. The reproduction thus secured was so delicate that often single sweat glands could be demonstrated, especially on the pulp of the fingers.

The duration of the test was 10 to 15 minutes.

⁸ Silverman, J. J., and Powell, V. E.: Studies on Palmar Sweating. *Am.J.M. Sc.* 208: 297-305, September 1944.

Sweat Tests of Other Parts of Body

Chinizarin method.—To demonstrate sweating on other parts of the extremities than the hands and the trunk, sweating reagents had to be placed directly on the skin.

Materials for the test included the following items:

1. Chinizarin 2-6 disulfonate (Burroughs Wellcome), a gray powder which turns red when in contact with sweat.
2. A tube of greaseless jelly.

The part to be examined was anointed with the greaseless jelly and allowed to dry. The patient was given 10 gm. of aspirin and hot fluids in large amounts and was placed in a baker for 45 minutes. He was then removed and wiped dry. Once he started to sweat, he always continued to do so. The dyestuff was applied to the skin by cotton wool and was not rubbed in. The powder turned to red in areas in which the patient sweated.

The duration of the test was 2 hours.

The color showed well on Kodachrome or on panchromatic black and white film (fig. 110).

Iodine-starch method.—If Chinizarin was not available, the iodine-starch method, although inconvenient, gave good results in experienced hands.⁹

Materials consisted of the following items:

1. Tincture of iodine 1.5 percent, 450 cc.
2. Castor oil, 50 cc.
3. Starch powder.

The part to be tested was painted with iodine. The skin was allowed to dry without wiping. Starch was pressed into the skin with cotton wool. When the patient was allowed to sweat, the sweat produced a dark blue to black color. If too much sweating occurred, the black powder would begin to flow.

Results were photographed on commercial film.

SKIN TEMPERATURE TEST

Painful coldness in fingers and toes was one of the commonest and most distressing symptoms in paralysis of the peripheral nerves. Furthermore, the possibility existed that the impaired circulation suggested by such evidence might impede recovery and that objective knowledge of the degree and mechanism of the vasomotor paralysis might be helpful in an attempt to alleviate it. The presence of paradoxical vasoconstriction might also call for immediate sympathetic block to avoid subsequent ischemic contractures and ankyloses.

⁹The effect of Fumethide iodide in connection with the Chinizarin or starch methods was not tested. The possibility of sensitization of denervated sweat glands to cholinergic drugs should not be overlooked.



FIGURE 110.—Hyperhidrosis in skin distribution of ulnar nerve after interruption, suture, and beginning regeneration of nerve (Chinizarin method). (Photograph taken with flashlight on panchromatic film.)

Impairment of vasomotor function could often be diagnosed by simple observation. The extremity was usually cyanotic, especially when dependent, and might remain so after being elevated. It might, on the other hand, be pale and fail to gain normal color when dependent. The effect of immersing the hand or the foot in cold or hot water might indicate the nature of the vasomotor disturbance.

These are all qualitative methods of examination. The only quantitative, accurate, and prompt method of judging the blood flow in the tissues is measuring the skin temperature by means of a thermocouple. The temperature indicates vasospasm, vasoparalysis, and vascular reactions to direct and indirect reflex stimuli.

Principle of test.—Since the interest is in the spot temperature rather than in the average temperature over the skin, the method of choice is the potentiometric method. If wires of two dissimilar metals, such as iron and constantan, are united by silver solder, a voltage is generated proportional to the temperature difference between the two junctions. One junction is used for measuring the skin temperature; the other is placed into ice water in a thermos bottle, to serve as the temperature reference junction. The increase or decrease of voltage is an accurate measure of the temperature on the warm junction. A portable direct current null potentiometer with a slide wire dial is calibrated in millivolts. The values in terms of degrees centigrade are read from a conversion table and added to or subtracted from the temperature in the thermos bottle.

In Leeds and Northrup instruments, one junction is at room temperature and the circuit compensated electrically. No ice bath is needed. Hence, the reading of the potentiometer is independent of changes in the room temperature. The dial of the potentiometer is calibrated directly in degrees centigrade. Point galvanometer, standard cell, battery, and galvanic keys are included. An uncalibrated galvanometer is used to show when the dial

reading is correct within the limits of error of the instrument; that is, $\pm 0.7^{\circ}$ C.

Materials.—Materials used in the test consist of the following items:

1. A portable direct current null potentiometer with millivolt indicator.
2. A switch box with six or more outlets.
3. Thermocouples, which may be bought ready made for measuring skin temperature or may be made. Constantan-iron wire can be bought by the foot and the number of junctions prepared by uniting the two wires with silver solder.

Technique.—The patient is placed on a bed in a constant temperature room of about 20° C. The two binding posts of the potentiometer are connected with the switch box from which go six leads, as follows: 1, for taking the room temperature; 2, for taking the patient's mouth temperature; 3, 4, 5, and 6, to the pulp of the index and little fingers of each hand.

If the foot is to be examined, the latter electrodes are placed on the plantar surfaces of the little toes and the dorsal interspaces between the big and second toes. The thermocouples are securely fixed to the skin with tape, which should not be wound around the fingers. Readings are taken in intervals of from 5 to 10 minutes from all thermocouples, which are connected in rapid sequence with the potentiometer by means of the switch-box.

After 30 to 40 minutes, heat pads are placed on the trunk, and the patient is covered with 3 or 4 blankets. The hands remain uncovered. When the temperature has leveled off after 1 hour, the heat pads and blankets are removed, and the normal hand is immersed in ice water for 3 to 5 minutes.

After the temperature of both hands has leveled off, the hand on the injured side is immersed in ice water for 3 to 5 minutes. Then the normal hand is immersed in hot water, and, finally, the hand on the injured side is similarly immersed.

A complete examination consumed about 4 hours but could be shortened in individual cases. The method was, however, reserved for selected cases.

Recording.—Temperature readings were plotted against time. Examples of results and of conclusions drawn from them are illustrated in figure 112 and table 10.

TABLE 10.—*Skin temperature in degrees centigrade (case 2)*

Procedure	Left index finger	Right index finger	Right little finger
Heating whole body	+12 +9	Percent -25	Percent +10 (-16)
Local ipsilateral icing (axon reflex)	- 7 -5.8	-18	
Local contralateral icing (spinal reflex)	- 4 -2	-50	

CASE HISTORIES

The following case histories are presented in the form of summarized progress notes from the hospital charts, to show convenient graphic presentation of motor and sensory signs and muscle atrophies. The final degree of recovery was unknown in most of these patients when these summaries were made.

As already indicated, the idea underlying these graphic presentations was to demonstrate simultaneously, as concisely and as precisely as possible the extent and severity of the initial motor and sensory defects, the type and location of surgical treatment, the distance from the injury to the muscle examined, the time factor, and the progress of recovery.

The key to the graphic records is as follows:

1. The numbers in the sets of unpainted hands and feet in the motor forms represent percentages of full average strength in the respective motions.
2. The exact spots on the sensory form on which the measured strength of the respective motions is recorded are indicated as in figure 99.
3. Blackout areas on the sensory forms indicate complete loss of all modalities of sensation. On the colored charts, which could not be reproduced for reasons of economy, loss of pain sense was indicated by uniformly red coloration and loss of touch sensation by uniformly blue coloration.
4. Figures framed by squares (red on the original charts) indicate the percentage of return of pain sensation and those framed by diamonds (blue in the original charts) indicate the percentage of return of touch sensation. The areas to which these figures refer are slightly shaded.

Case 1. Injury of left ulnar nerve above elbow

9 June 1944. Fell on piece of glass during maneuvers. Complete sensory and motor paralysis of left ulnar nerve below wrist flexor (figs. 94 and 111).

19 July 1944. The ulnar nerve was exposed 6 inches above and 12 inches below the elbow. A neuroma ($\frac{3}{4}$ inch) was resected 2 inches above the elbow. The ulnar nerve was transposed and sutured end-to-end.

3 Jan. 1945. No return of motor or sensory function. Removal of tantalum cuff. Electrical stimulation of the nerve $1\frac{1}{2}$ inches below the suture line resulted in flexion of the end phalanges of the ring and little fingers and sensation radiating downward to the little finger. Handprint shows clawing of little, ring, and index fingers, atrophy of abd. dig. V, of 4th and 3d interossei, and of thumb adductor muscles. Hence, the thumb has sunk down.

23 Aug. 1945. No motor improvement, slight shrinkage of analgesic area at wrist (overlay). Has worked an average of 40 hours a week as maintenance man in a textile mill during the last 7 months and improved the configuration of his hand slightly. The index and ring fingers have straightened. The tone of the adductor has improved. No more can be expected in 13 months with a distance of $16\frac{1}{2}$ inches to grow.

26 Nov. 1945. Fair strength in the thumb adductor and beginning motion in the abd. dig. V. This means $16\frac{1}{2}''/16$ m. Both muscles have gained in volume; all fingers straightened. Sensation still absent in the entire area of isolated ulnar supply.

17 June 1946. Good improvement of strength of all hand muscles except for adductor of little finger. Return of pain and touch sensation down to tip of little finger $21''/23$ m.

Summary.—Return of motor function of intrinsic hand muscles and sensitivity on time,

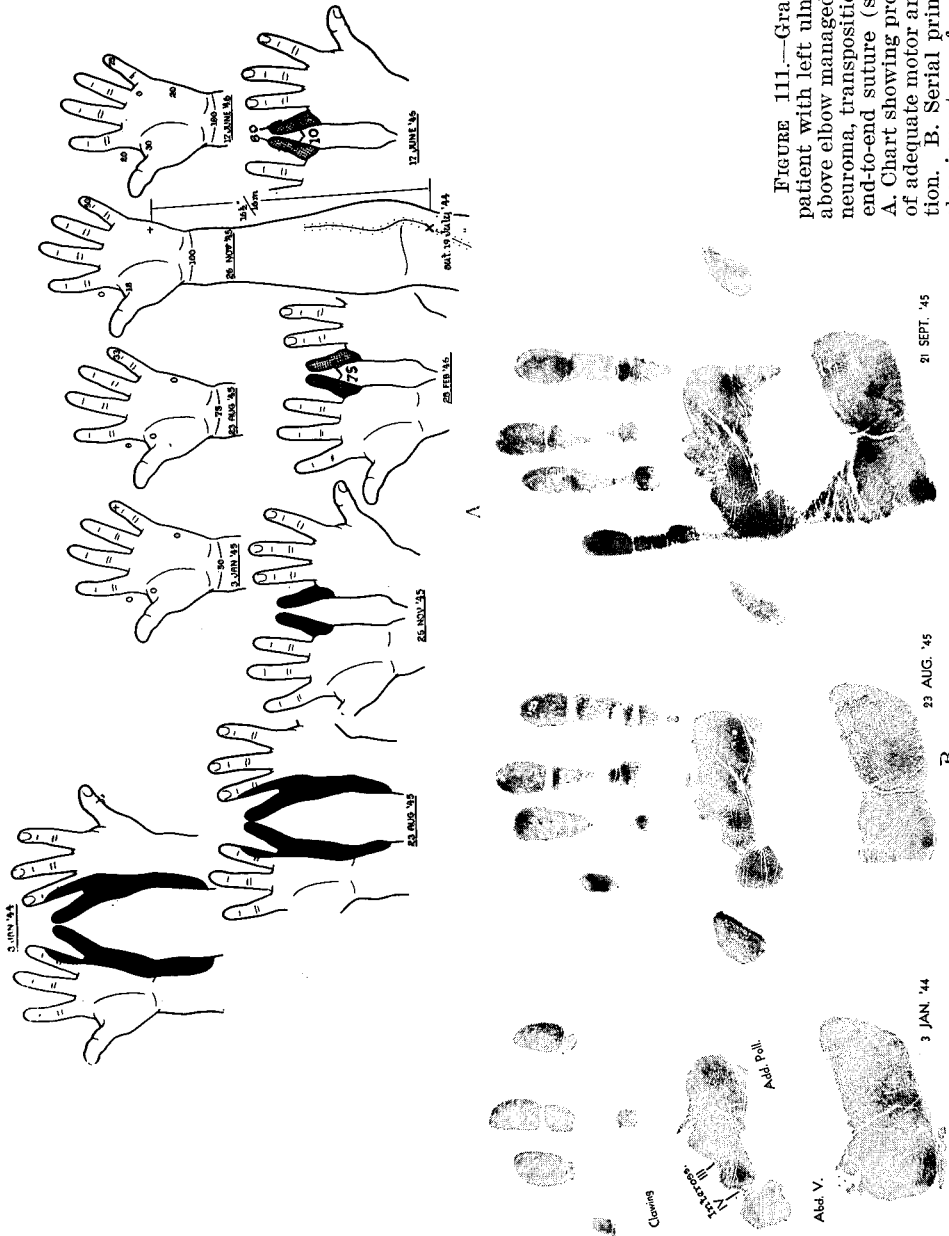

FIGURE 111.—Graphic record of patient with left ulnar nerve injury above elbow managed by resection of neuroma, transposition of nerve, and end-to-end suture (see also fig. 94). A. Chart showing progressive return of adequate motor and sensory function. B. Serial prints of left hand, showing return of muscle volume.

following end-to-end suture and transposition of ulnar nerve. One may argue as to whether 20 percent of the average represents adequate strength in the abd. dig. V. Further improvement can be expected, but to all intents and purposes, this patient has even now a perfectly useful hand as evidenced by the fact that he has earned a normal livelihood in his trade as a mechanic.

Case 2. Injury of right median nerve near elbow

17 Jan. 1946. Complete motor and sensory paralysis of radial nerve, complete sensory and partial motor paralysis of median nerve with mild causalgia following severe lesion on radial side of volar aspect of right forearm near elbow (fig. 112).

16 and 19 Apr. 1946. Procaine blocks of right stellate ganglion with good result.

17 Apr. 1946. Complete analgesia and anesthesia in distribution of the radial, median, and musculocutaneous nerves. No radial or ulnar pulses, no oscillometric readings at wrist.

Sweating is almost absent in thumb, index, and middle fingers, and on thenar and metacarpal area of the index. It is poor over metacarpal area of middle finger and adductor region of palm.

Skin temperature of right index finger is 3.5° C., while that of the left index finger rises 11.8° C. In other words, there is reflex vasoconstriction in right index finger on heating the body. The temperature of the right little finger rises but lags 2.5° C. (23 percent) behind that of the normal hand.

29 Apr. 1946. Operation. The radial nerve was found to be interrupted, the ends so far apart that they were left alone for later tendon transplant. The median nerve was embedded in dense scar tissue below the pronator muscle but in continuity. It was freed from scar and injected with saline, which passed freely.

4 Sept. 1946. Sensation for touch and pain has partially returned over the palm and for subcutaneous pressure in thumb, index, and middle fingers.

14 May 1947. Thirteen months after neurolysis, sensation was normal in the palm and basal phalanges of index and middle fingers; touch sensation had returned in the distal phalanges; analgesia continued. Sweating had returned to thumb and index finger and to the basal phalanx but not yet to the distal phalanges of the middle finger. It was decreased over the thenar.

Skin temperature is shown in table 10.

Summary.—The axon reflex has recovered—as is the rule—earliest and relatively best. The vasomotor reaction of the little finger has improved compared with the figures of a year ago (–23 percent) but still lags 16 percent behind the normal side, although the ulnar nerve was at no time involved.

Case 3. Injury of right ulnar nerve above elbow

11 Dec. 1944. Wounded by shell fragments in right upper arm with severance of the ulnar nerve 2 inches below the axilla (fig. 113).

7 Apr. 1945. Nerve sutured end to end overseas without transposition and under considerable tension.

21 Sept. 1945. Patient's transfer to Cushing General Hospital requested because there seemed to be no indication of returning function. X-ray suggested separation of suture. At the time of his arrival at Cushing, intraneural stimulation at elbow 6 inches below suture line gave acute sensation in finger. The tantalum cuff was removed and an entirely satisfactory nerve suture found. Sensation on nerve stimulation was present at all points in the distal portion of the freed nerve, though not as acute as in the proximal portion. No motor reaction could be expected except in wrist and deep finger flexors, which seemed to be intact.

10 Jan. 1946. No improvement of motility or sensation in hand, but intraneural stimulation at wrist showed abduction of 5th finger, i.e., 18"/9 m.

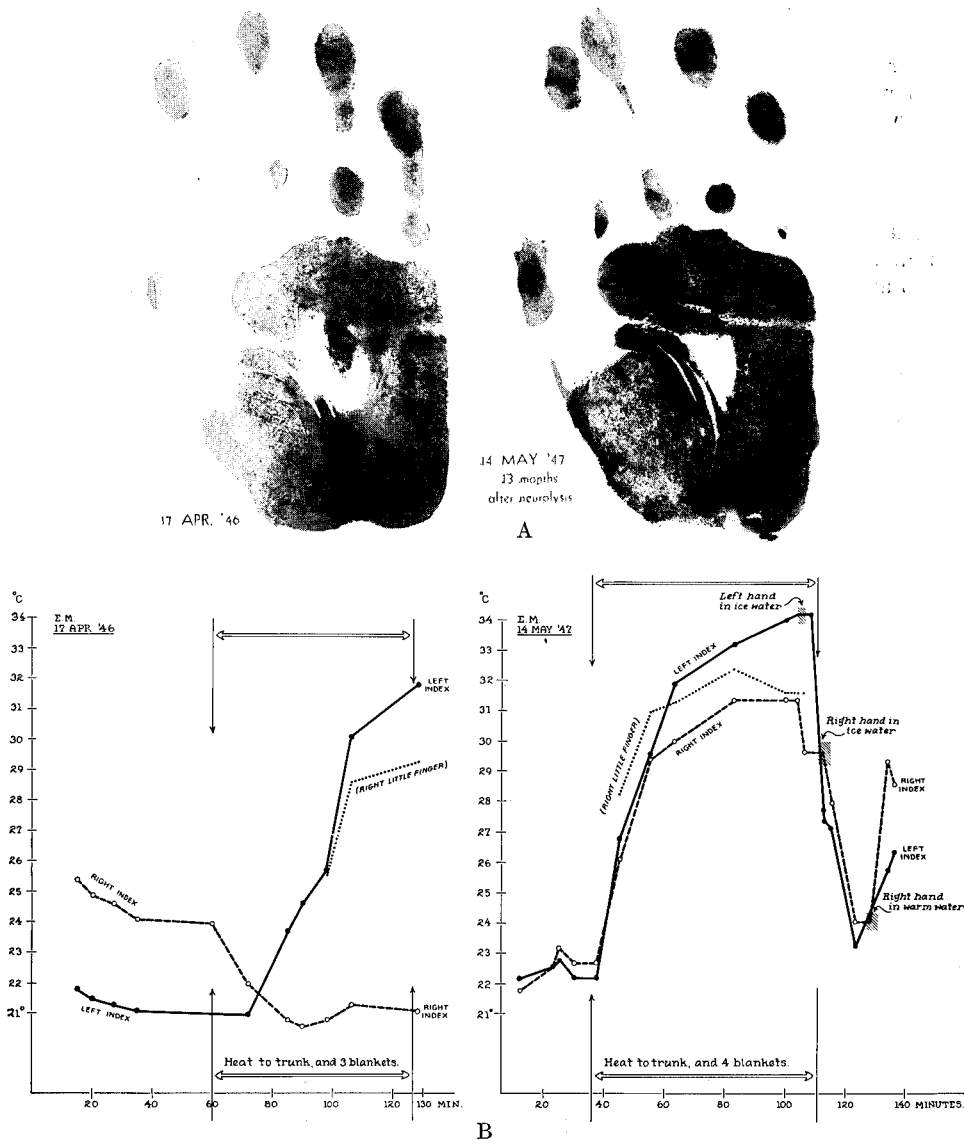

FIGURE 112.—Graphic record of patient with complete sensory and partial motor paralysis of right median nerve, managed by neurolysis. A. Sweat handprints taken at 13-month interval (tannic acid-ferric chloride method). Second print shows gradual return of sweating, which is still incomplete over middle and terminal phalanges of middle finger. B. Skin temperature curves of same patient taken at 13-month intervals. The first examination shows vasoconstriction of right index finger. The second shows lagging of temperature increase on heating body of right index and little fingers in comparison with uninjured side. There is also lagging decrease of skin temperature in injured side for direct cooling as well as cooling of opposite side (axon reflex and spinal vasomotor reflex).

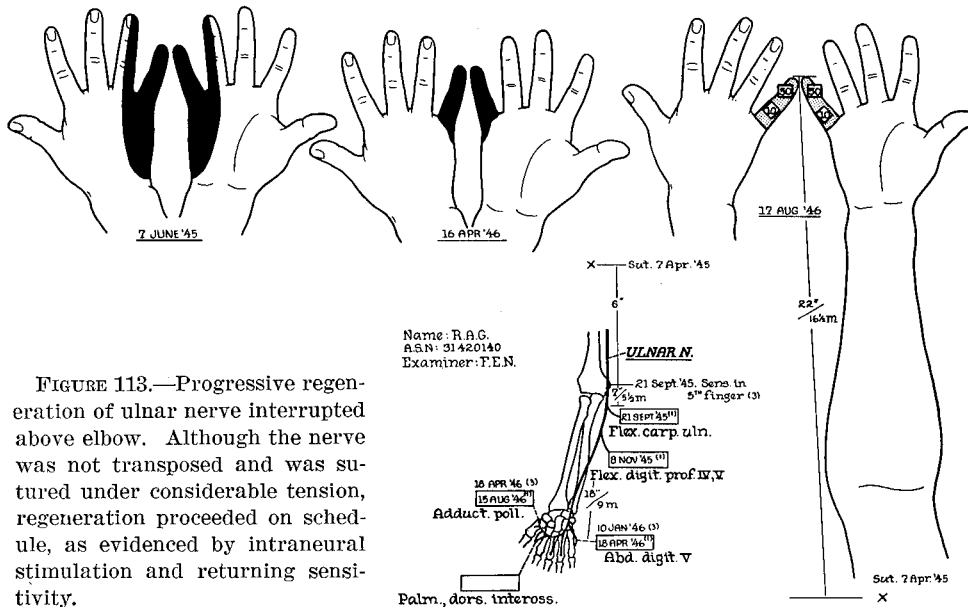

FIGURE 113.—Progressive regeneration of ulnar nerve interrupted above elbow. Although the nerve was not transposed and was sutured under considerable tension, regeneration proceeded on schedule, as evidenced by intraneural stimulation and returning sensitivity.

18 Apr. 1946. Definite voluntary flicker in abd. dig. V and normal sensitivity in overlay area of palm not yet in isolated supply area of little finger.

15 Aug. 1946. Intraneural stimulation gives strong contraction in short thumb flexor and some in opponens. There is good recovery of pain and touch sensation down to the tip of the little finger; this means 22"/16½ m. There is still a mild inability to extend fully the last two fingers. This is so little disabling that patient rejected suggestion of transferring his sublimus tendon to the dorsal aponeurosis.

Summary.—Good regeneration despite tension on nerve scar, anticipated by intraneural stimulation.

Case 4. Injury of right ulnar nerve below elbow

31 May 1944. Wounded in upper third of right forearm by rifle bullet, with complete sensory and motor ulnar paralysis below the wrist flexors. Patient insisted on existence of considerable improvement, which delayed operation for 3½ months (fig. 114).

12 Sept. 1944. The nerve was freed 3 inches both above and below elbow and found completely interrupted. It was transposed and sutured end to end over a 5-cm. gap.

10 April 1945. Marked atrophy of thumb and of adductor and abductor of little finger with clawing.

6 July 1945. Although there is no motor or sensory improvement in the hand, its configuration has much improved. The little finger has been limbered up and straightened and the thumb adductor has better tone.

25 Sept. 1945. Patient has improved to the degree that he is acceptable for reenlistment in the Regular Army. There is 70 percent strength in the deep flexor of the little finger, 45 percent in the abductor dig. V, and 20 percent in the thumb adductor. There is 75 percent return of touch sensation down to the tip of the little finger and practically full pain sensation. The handprint shows good increase in the volume of the abd. dig. V and reappearance of the thumb adductor.

Summary.—This man has used his right hand with unusual energy for 5 months in his occupation as a tree surgeon. This may have contributed to the excellent final



FIGURE 114.—Handprints of patient with complete interruption of right ulnar nerve below elbow, managed by transposition and end-to-end nerve suture. Serial prints show good return of motor and sensory function. The atrophy of the intrinsic hand muscles and the clawing present at the first study disappeared almost completely over the 12-month period of observation, with an increasing distance of 14 inches. The patient constantly used his hand because he wished to reenlist in the Regular Army, for which he was accepted.

FIGURE 114.—Handprints of patient with complete interruption of right ulnar nerve below elbow, managed by transposition and end-to-end nerve suture. Serial prints show good return of motor and sensory function. The atrophy of the intrinsic hand muscles and the clawing present at the first study



FIGURE 115.—Handprints of patient with partial ulnar neuromyolysis. Note rapid return of motor and sensory function.

FIGURE 115.—Handprints of patient with partial ulnar neuromyolysis. Note rapid return of motor and sensory function.

result, despite a lapse of 16 months from the time of interruption of the nerve to the reinnervation of the muscles. 14"/12 m.

Case 5. Injury of right ulnar nerve above wrist

11 Sept. 1944. Received laceration of right forearm with compound fractures of distal ends of radius and ulna resulting in complete motor and sensory paralysis of right ulnar nerve below wrist flexor and finger flexors when struck by tank during attack (fig. 115).

There was bony union of radial fracture and no union of ulna when patient arrived at Cushing General Hospital. The paralysis continued unchanged for 4 months. The ring and little fingers showed clawing. The last two interossei and the abductor dig. V were atrophied. It was therefore decided to explore the ulnar nerve.

12 Jan. 1945. Incision over course of the ulnar nerve extending 3 inches above and 6 inches below elbow joint. Dense scar found 2 inches distal to joint. A neuroma involved less than a third of the nerve, which felt moderately hard at this point. Saline injected flowed slowly through the scar. The nerve branches to the flexor carpi ulnaris and to the finger flexors came off proximal to the scar and reacted well on electrical stimulation. There was no reaction in the intrinsic hand muscles but near-normal sensory response from a point 2 inches distal to scar. The nerve was transposed to a more superficial level to provide a better bed but otherwise left alone.

22 May 1945. Beginning strength in abductor dig. V and thumb adductor. Can innervate all interossei but without power. The fingers have straightened. The atrophy of the interossei is receding but that of the abductor dig. V and thumb adductor has progressed. Touch and pain sensations have markedly improved down to the fingertips.

24 Sept. 1945. Muscle strength and sensibility have continued to improve, though very slowly, while the volume of the intrinsic hand muscles has returned to normal except for the third interosseus.

Summary.—One is inclined to believe that the return of function was influenced by the neurolysis. If this were not the case and regeneration had started soon after injury, 10"/8 m. and even 14"/8 m. would represent an average growth rate for a completely interrupted sutured nerve. The completeness with which the marked muscle atrophy was restored to normal within 4 months exceeds anything seen in complete interruption of a nerve. The slow progress in regaining muscle strength, on the other hand, may be due to the fact that the patient, a college student, could not be persuaded to do hard manual work. This case is considered to be an example of partial intraneural interruption and scarring. Exploration and neurolysis were certainly indicated and possibly helpful in hastening recovery.

Case 6. Injury of left ulnar nerve above elbow

1 June 1944. Wounded by mortar shell at junction of middle and lower third of upper arm. The left forearm and hand became immediately useless, the little and ring fingers numb. The wound was debrided the same day and the ulnar nerve explored. Its sheath was intact but the nerve appeared narrowed and felt as if about one-half of its fibers were severed. The nerve was left alone (fig. 116).

11 Oct. 1944. On the patient's arrival at Cushing General Hospital, the intrinsic hand muscles were paralyzed and there was considerable atrophy, with clawing of last two fingers. Sensitivity in little finger absent.

20 Nov. 1944. Nerve explored and found in perfect condition. Electrical stimulation gave contraction of wrist and finger flexors but not of intrinsic hand muscles. Sharp pain response in little finger from most distal part of incision.

29 Jan. 1945. Touch and pain sensation down to fingertip is first sign of returning nerve function. 22½"/8 m. This recovery rate of 2½ inches per month suggests that the sensory fibers had been spared in the intraneural injury.

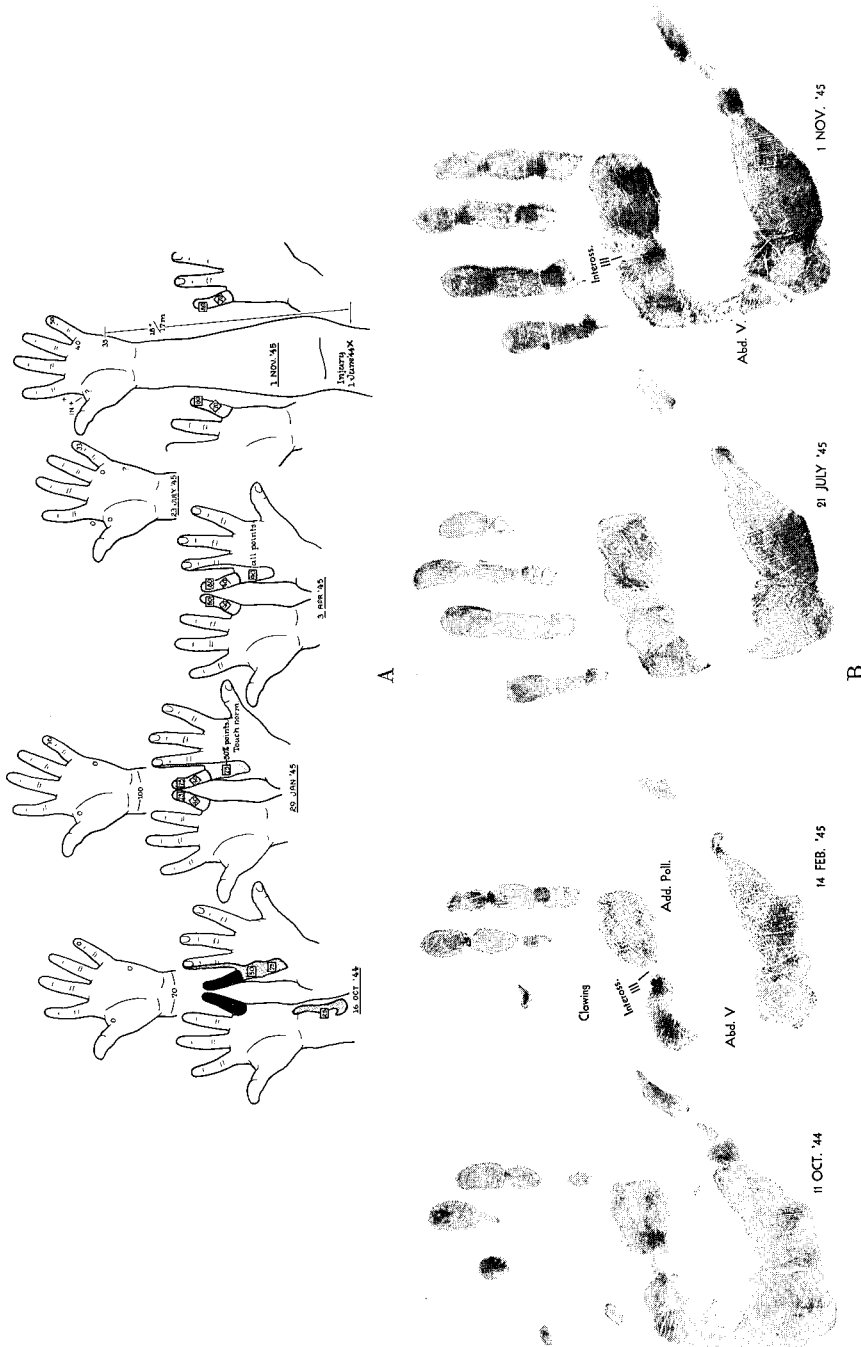

FIGURE 116.—Graphic record of patient with complete paralysis caused by contusion of left ulnar nerve in upper arm. The time required for return of function suggests that the motor fibers were interrupted intraneurally and had to grow again while the sensory fibers were only contused and therefore recovered much more rapidly. A. Chart showing progressive return of motor and sensory function. B. Serial handprints. Note that clawing had disappeared and that the volume of the intrinsic hand muscles had begun to increase rapidly when the patient was discharged.

21 July 1945. Questionable flicker in abductor digiti V. Muscle atrophy, which had increased until February, has begun to recede. The last fingers have been limbered up and straightened.

1 Nov. 1945. All intrinsic hand muscles are innervated, though the adductor pollicis reacts only to intraneural stimulation. The atrophy of abductor dig. V has markedly improved. 18"/17 m. Only mild hypesthesia and hypalgesia present in little finger.

Summary.—This soldier, although a college student in civilian life, has worked his hand hard, lacing and holding wire nets and cables 50 hours a week for 7 months. He has limbered up perfectly his contracted last two fingers and increased the volume of his paralyzed muscles better than expected. He was fortunate to be debrided the day of injury by an experienced neurosurgeon, who explored and judged correctly the condition of the nerve and gave a complete description of his findings. It would have saved the patient the reexploration of 20 Nov. 1944—which did no harm anyway—had we known the oversea surgeon at that time as we did shortly afterward. The time sequence of recovery suggests that the motor fibers to the intrinsic hand muscles had been interrupted intraneurally and had to regenerate in the usual growth rate, whereas the sensory fibers were only contused. A number of them regained function much earlier than could be expected from regrowth, while others lagged as much as the motor fibers.

Case 7. Injury of left median nerve in forearm

28 Aug. 1944. Wounded by shell fragments in left forearm 2 inches above wrist with complete motor and sensory median paralysis (fig. 117).

3 Dec. 1944. Median nerve mobilized, sutured, and encased in performed tantalum cuff in general hospital overseas.

30 Jan. 1945. Clawing of index and middle fingers.

19 Mar. 1945. Cuff removed, revealing an indurated nerve. Electric stimulation 1½ inches below suture line produced only sensory response in index and middle fingers.

4 Apr. 1945. Marked atrophy of opponens and abd. poll. br. muscles. Straightening of index and middle fingers.

26 July 1945. Just beginning return of touch and pain sensitivity down to fingertips and voluntary contraction of short thumb abductor.

20 Oct. 1945. Voluntary contraction of short thumb abductor and of opponens on intraneural stimulation at wrist. Volume of opponens and abd. poll. br. muscles restored, though not yet completely.

28 Jan. 1946. All intrinsic muscles are innervated. Sensation improved to degree that remaining deficit does not impair earning capacity. Patient has worked in his pre-war occupation, as plastic moulder, an average of 46 hours a week during the last 9½ months.

Summary.—The long delay of motor recovery, 4"/11 m., in a median or ulnar suture close to the wrist is not unusual. The early return of pain sensation in the median distribution of the palm is no sign of regeneration of the median nerve but of the returning overlap from radial and ulnar nerves. The eventual degree of strength, especially in the opponens, cannot be predicted, but the good and rapid return of muscle volume is promising. The crucial factor in a median nerve paralysis is the satisfactory return of sensitivity in the fingertips, rather than of motor strength, which usually can be compensated for by the adductor pollicis and the ulnar-innervated part of the short thumb flexor or, in the worst cases, by transplantation of a tendon.

Case 8. Injury of right ulnar and median nerves above elbow

12 Nov. 1944. Wounded by shell fragment. Compound comminuted fracture right humerus, lower third and complete paralysis of median and ulnar nerves (fig. 118).

24 Apr. 1945. Both nerves were found interrupted above the elbow and sutured end to end over 8-cm. gap with mobilization of nerves between axilla and middle of forearm. Transposition of ulnar nerve. Humerus plated.

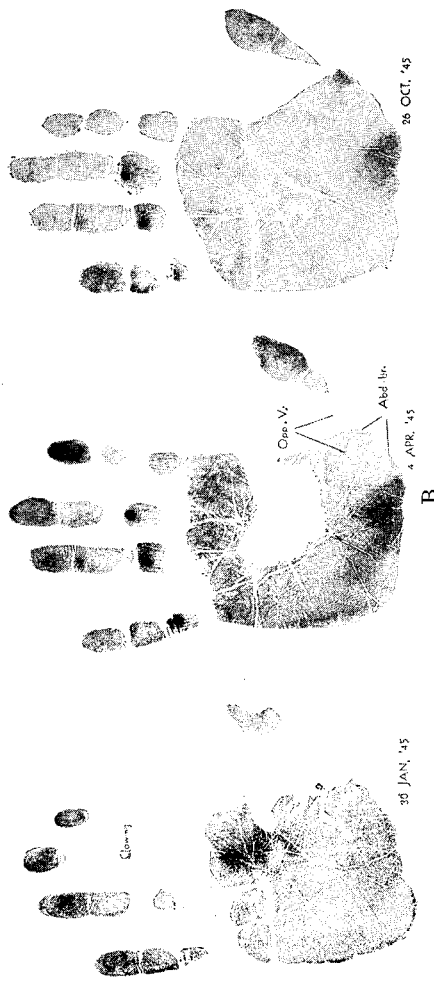
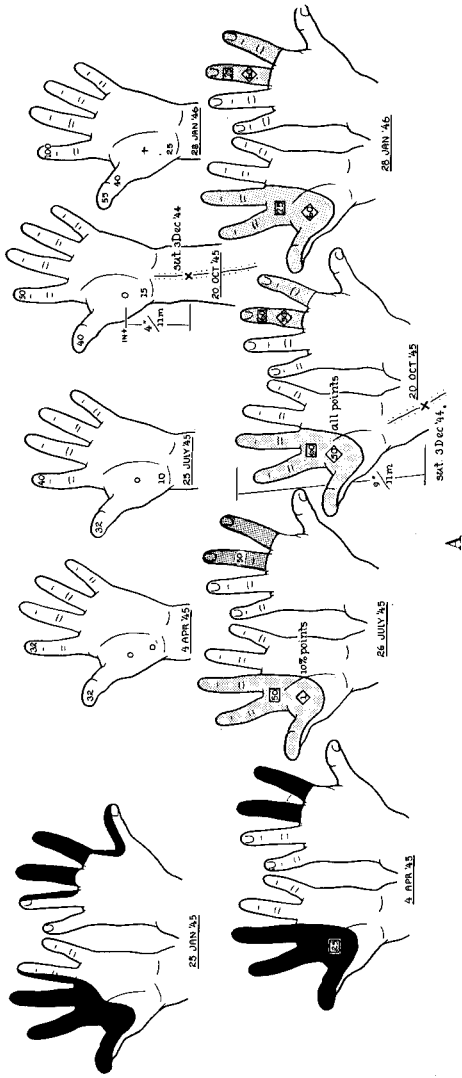

FIGURE 117.—Graphic record of patient with interruption of left median nerve in forearm. The delayed return of motor function in a lesion close to the wrist was frequent (4"/11 m.). The slow but progressive improvement of touch sensation in the fingertips and the rapid return of muscle volume suggest that the final result in this case will be satisfactory. A. Chart showing progressive return of motor and sensory function. B. Serial handprints showing return of muscle volume.

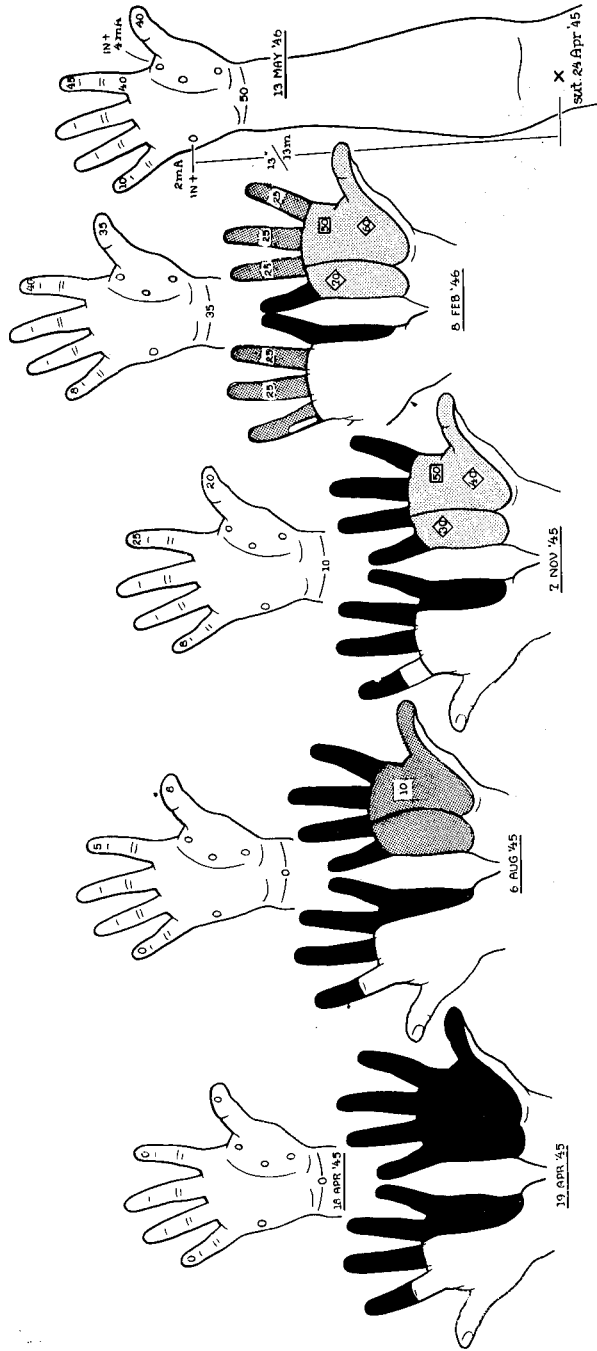

FIGURE 118.—Graphic record of patient with interruption of right ulnar and median nerves above elbow, managed by mobilization of both nerves between axilla and forearm, transposition of ulnar nerve, end-to-end suture of both nerves, and plating of humerus. Intraneural irritability of ulnar nerve at wrist appeared on schedule (13"/13 m.) but did not improve in the next 3 months.

Failure of progression and complete absence of irritability of the median nerve are not necessarily indicative of a poor prognosis because the nerve fibers may have to grow from the upper end of the mobilized part of the nerve, which would mean a progression of 19"/16 m. Beginning return of sensitivity in the first three fingers gives hope for an eventually useful hand.

6 Aug. 1945. Long thumb flexor innervated. Return of pain sensation in overlay area of median and ulnar distribution of palm.

7 Nov. 1945. Wrist and long finger flexors of ulnar and median innervated.

8 Feb. 1946. Forearm flexors improved but intrinsic hand muscles absent. Returning pain sensation in fingers except for little finger.

13 May 1946. Intraneural stimulation of ulnar nerve at wrist gives contraction of abductor V with 2 MA and of adductor pollicis at 4 MA. Intraneural stimulation of median nerve at wrist gives no motor reaction.

9 Aug. 1946. Improvement of sensation but little of motion. Contracture of fourth and fifth fingers is most distressing and tendon transplant will probably be needed.

Summary.—Patient has worked during the last year in his trade as fur cutter, averaging 40 hours a week, despite handicap caused by absence of thumb opposition and by flexion contractions of ring and little fingers. Distance from suture to hand muscle is 13 inches, the time elapsed 13 months. However, the nerves were mobilized another 6 inches up to the axilla and may have to grow from this point down. This would mean 19"/16 m. at the time of discharge. Patient is discharged on his own request. The final result remains to be seen. Tendon transplants may be eventually necessary.

Case 9. Injury of right radial nerve above elbow

9 Apr. 1945. Wounded by rifle bullet, sustaining compound comminuted fracture of right humerus with complete radial paralysis below level of triceps muscle (fig. 119).

24 May 1945. Radial nerve suture with tantalum wire overseas. Tantalum foil. No union of fracture.

10 July 1945. Arrival at Cushing General Hospital. Still complete motor and sensory radial paralysis. Good bony union of fracture.

9 Oct. 1945. First motion in brachioradial muscle. Beginning touch sensation on back of hand.

4 Dec. 1945. Beginning dorsiflexion of hand and extension of fingers.

13 Feb. 1946. Thumb extension and abduction, improving touch and pain sensation.

Has worked a 50-hour week during last 4 months as a grocery store clerk.

Summary.—Excellent result of early end-to-end suture of radial nerve with fracture of humerus 10"/8¾ m.

Case 10. Injury of left radial nerve (at operation) above elbow

30 May 1944. Simple complete fracture of lateral condyle of left humerus (fig. 120).

13 June 1944. Open reduction with removal of fragment. Radial nerve retracted.

20 June 1944. Wristdrop, inability to extend thumb or fingers, and loss of sensitivity on radial part of dorsum manus. Patient was transferred to Cushing General Hospital for neurosurgical treatment when no improvement was apparent 3 months after operation.

10 Oct. 1944. Arrival at Cushing General Hospital. Wrist and finger extensors showed fair strength and the long thumb extensor some motion. There was still complete analgesia. However, 40 percent touch sensation had returned in one-tenth of the normal number of touch points.

23 July 1945. Thirteen months after operative traction paralysis, strength of finger extensors was full, of wrist extensors and long thumb abductor 75 percent, of thumb extensors about 50 percent. Pain and touch sensitivities had returned 75 and 85 percent, respectively; that is, 13"/13 m. Patient has worked in his own trade as hydraulic press operator on a 48-hour week during the last 6 months.

Summary.—This is an example of a radial nerve contusion by the retractor during operation. There was justifiable concern as to the degree of injury when no return of function was observed in 3 months, with a distance of 3 inches from the site of injury to the wrist extensor. However, improvement became apparent 1 month later and progressed satisfactorily despite the delay.

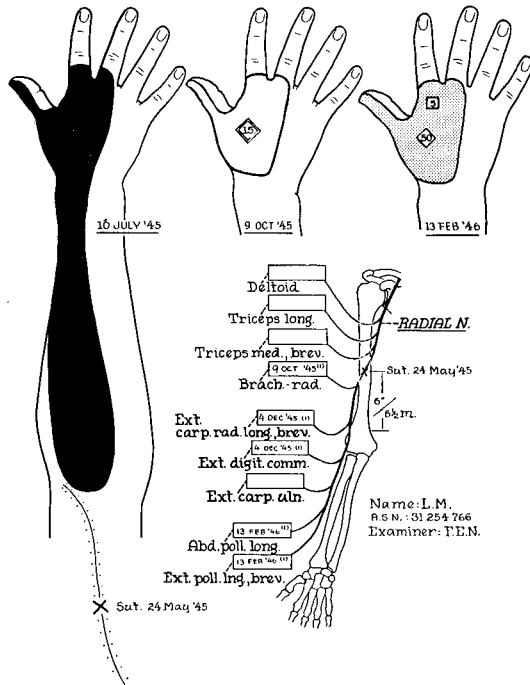

FIGURE 119.—Graphic record of patient with interruption of right radial nerve and fracture of humerus. Chart shows excellent motor and sensory result of early end-to-end nerve suture.

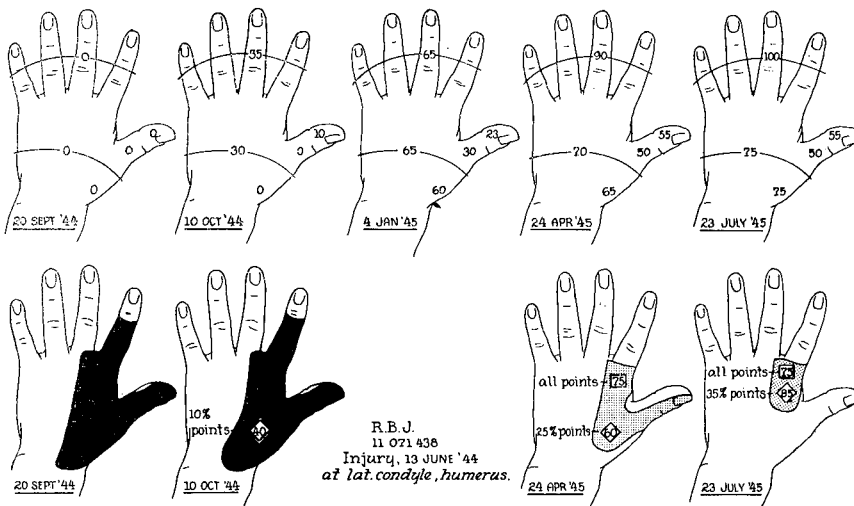

FIGURE 120.—Graphic record of patient with contusion of left radial nerve by traction during open reduction of fracture of humerus, with removal of lateral condyle. A week later, complete radial paralysis was evident. Spontaneous delayed recovery occurred.

Case 11. Injury of left sciatic nerve in upper third of thigh

7 July 1944. Wounded by shell fragments in upper third of left thigh with motor and sensory sciatic paralysis below the knee. Pin and needle sensation, most marked over dorsum of foot, had suggested returning function and delayed exploration (fig. 121).

7 Dec. 1944. Operation. Incision from gluteal fold to popliteal space and freeing of nerve. The nerve was completely interrupted in the middle of the thigh, about 4 inches above its bifurcation. It was fully mobilized, and the tibial and peroneal portions were isolated and separately sutured end-to-end after resection of neuromas and gliomas, over a gap of 2 inches. The knee was flexed to 90°.

18 Jan. 1945. Cast removed and leg gradually stretched to 150° until February 1st.

8 Oct. 1945. First sign of returning function in gastrocnemius which is just in time (10"/10 m.).

18 Mar. 1946. Good strength in gastrocnemius and trace in tibialis ant. Intraneural stimulation of peroneal at fibular head gave sensory radiation but no motion. 11"/15 m.

19 July 1946. Voluntary contraction of toe extensors and questionable reaction of peroneal muscles to intraneural stimulation. No sensory improvement except for overlay areas. No more can be expected for another year. Has worked as a punch press operator for over a year with a weekly average of 50 hours.

Summary.—This is an example of a high sciatic interruption, sutured after 5 months' delay. Patient made a good motor recovery and was clearly going on to a satisfactory end result, only slightly behind schedule. Began gainful employment 7 months after suture.

Case 12. Injury of tibial and peroneal components of left sciatic nerve

25 June 1944. Wounded by mortar shell fragment involving the left sciatic nerve 3 inches below sciatic notch with complete paralysis (fig. 122).

4 Aug. 1944. Returning function of hamstrings and sensation in peroneal distribution. Complete motor paralysis in tibial and peroneal distribution.

20 Oct. 1944. Freeing and mobilization of sciatic nerve from gluteal crease to popliteal space. Peroneal portion separated from tibial and found intact. Injected saline passed freely. A neuroma and 5 cm. of scar were resected from the tibial portion and the ends united, using tantalum wire. Separate preformed tantalum cuffs were placed around each nerve. Knee splinted at 90° flexion.

14 Nov. 1944. Cast changed.

27 Nov. 1944. Cast removed and patient allowed to straighten leg gradually.

8 Jan. 1945. Cuffs removed. Electrical stimulation 6 inches below cuff gave sensation in peroneal nerve and 4 inches below suture in tibial; that is, a growth rate of 4"/3 m. No motor reaction.

27 Feb. 1945. Left on work furlough as truckdriver. Mild peroneal sensory disturbance at capit. fibul. following mobilization and handling of nerve.

5 May 1945. In motorcycle accident, fractured right and left radii below the heads. Returned to hospital.

20 June 1945. Beginning motor function in both tibial and peroneal nerves. 13 $\frac{3}{8}$ " / 8 $\frac{1}{2}$ m. = 1 $\frac{5}{8}$ " p.m.

9 Aug. 1945. Good extension and flexion of foot, not of toes; good eversion and inversion of foot.

15 Nov. 1945 and 16 Jan. 1946. Further improvement of mobility and sensitivity but still complete analgesia and anesthesia of the sole.

19 Apr. 1946. Increase in strength of all muscles but toe flexors. Sensitivity of sole still absent. Its return cannot be expected until end of 1946. Has worked the last 8 months on a farm about 40 hours a week without subjective or objective difficulties.

Summary.—This is an example of high sciatic injury with early return of hamstring

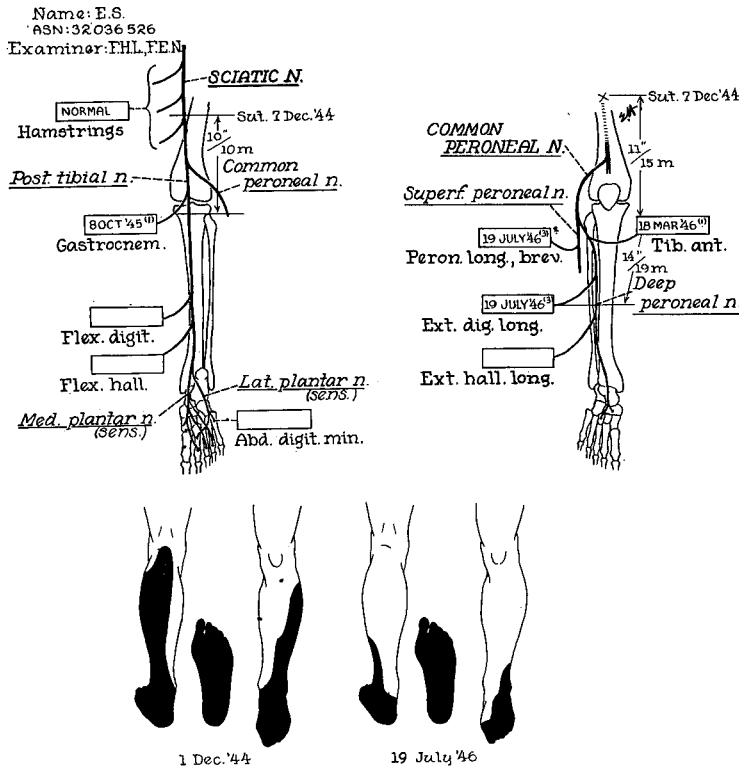

FIGURE 121.—Graphic record of patient with high interruption of left sciatic nerve, managed by end-to-end suture of tibial and peroneal components. Operation was delayed for 5 months because of presumed sensory improvement. Good motor recovery is evident and is only slightly behind schedule. In this case, no sensory improvement can be expected for another year.

activity and peroneal sensitivity suggesting that the peroneal portion was at least partially preserved. Operative inspection and saline injection strengthened this assumption, although electrical stimulation elicited pain only. The tibial portion was resected and sutured over a 5-cm. gap. The almost simultaneous return of motor function in tibial and peroneal nerves indicates that the nerve fibers had been interrupted also in the grossly intact peroneal nerve and had to regenerate from the place of injury. Most of the return of tibial sensitivity, if not all, is due to overlap, but return of sensation in the sole cannot be expected in less than 21 to 30 months. Trophic disturbances and pains have not been present at any time. Has worked on a farm, and the last 3 months in his own profession as auto repairman in a garage, about 40 hours a week, without difficulties. This is a satisfactory result in adequate time. It shows that a truckdriver may be able to leave the hospital and return to commercial work 9 months after a high sciatic injury with suture of its tibial portion.

Case 13. Injury of left tibial and peroneal nerves above popliteal space

12 May 1945. Wounded on Okinawa by mortar shell 3½ inches above popliteal space. Complete motor and sensory sciatic paralysis in the leg. Evacuated to Zone of Interior 3 June 1945 (fig. 123).

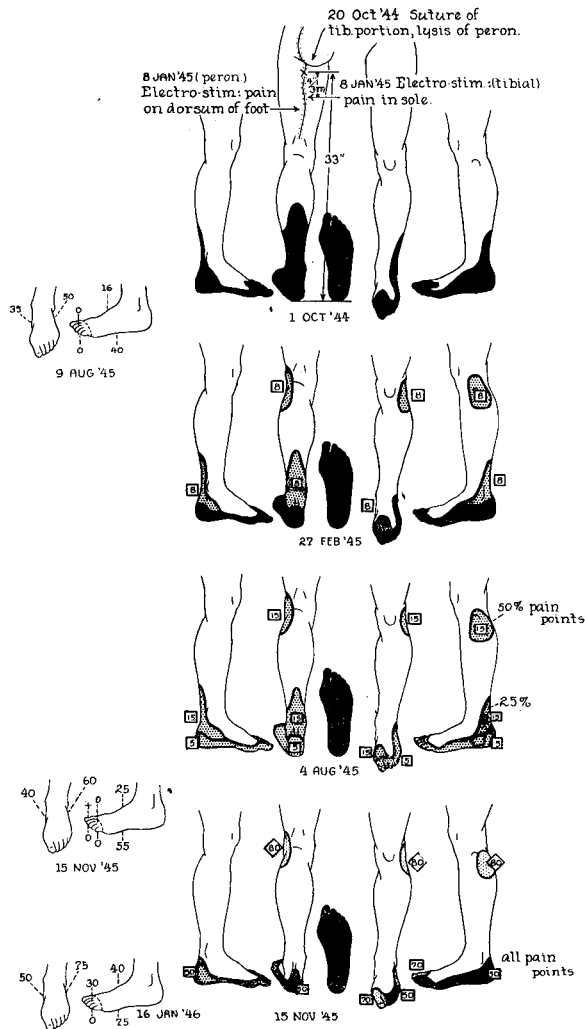

FIGURE 122.—Graphic record of patient with high left sciatic injury, with complete interruption of tibial portion and contusion of peroneal portion. The injury was managed by long mobilization of the sciatic nerve and resection and end-to-end suture of the tibial portion. The peroneal portion was found intact and was left alone. Electrical stimulation of the nerves 6 inches and 4 inches, respectively, below the injury gave sensation in the peroneal and tibial skin areas. Beginning motor function was observed in both nerves 8 months after suture, with satisfactory progress.

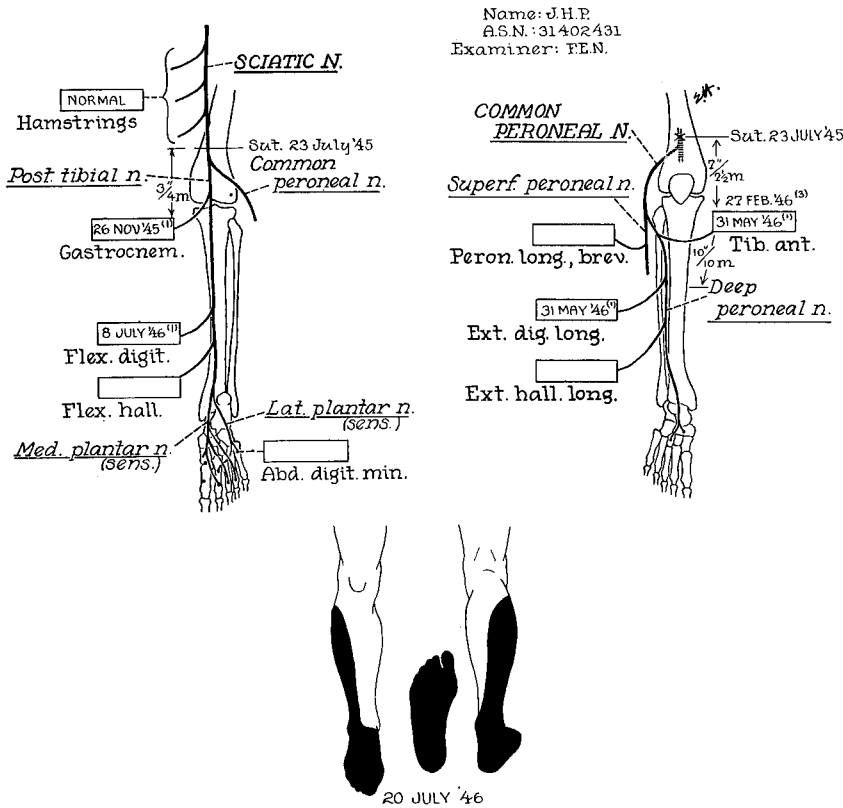

FIGURE 123.—Graphic record of patient with interruption of both the left tibial and the left peroneal nerve above popliteal space, managed by early end-to-end suture. Good progress of motor recovery restored the patient to full earning capacity. Return of sensitivity could not yet be expected (15"/12 m.).

23 July 1945. Sciatic nerve freed from junction of upper and middle third of thigh down to head of fibula. The nerve was almost completely interrupted. No sensory or motor response to electrical stimulation was obtained in the tibial component, and very slight sensory response in the peroneal. The nerve was mobilized throughout the length of the incision, the scarred ends resected, and each component sutured separately end to end over a 5-mm. gap with tantalum wire in 90° flexion of the leg. The leg was gradually straightened after 7 months of immobilization and was straight on 6 Nov. 1945.

26 Nov. 1945. First sign of regeneration: voluntary contraction of gastrocnemius. 3½"/4 m.

27 Feb. 1946. Contraction of tibialis ant. on intraneural stimulation of peroneal in popliteal space.

31 May 1946. Voluntary contraction of foot and toe extensors.

8 July 1946. Voluntary contraction of toe flexors. No innervation of long or short peroneal muscles. No return of sensitivity. Is able to walk without brace. Has worked as stock clerk for 8 months without difficulty.

Summary.—This is an example of early suture of tibial and peroneal nerves at the level of the lower third of the thigh. Good functional recovery permitting gainful employment 6½ months after injury and full working capacity in less than a year.

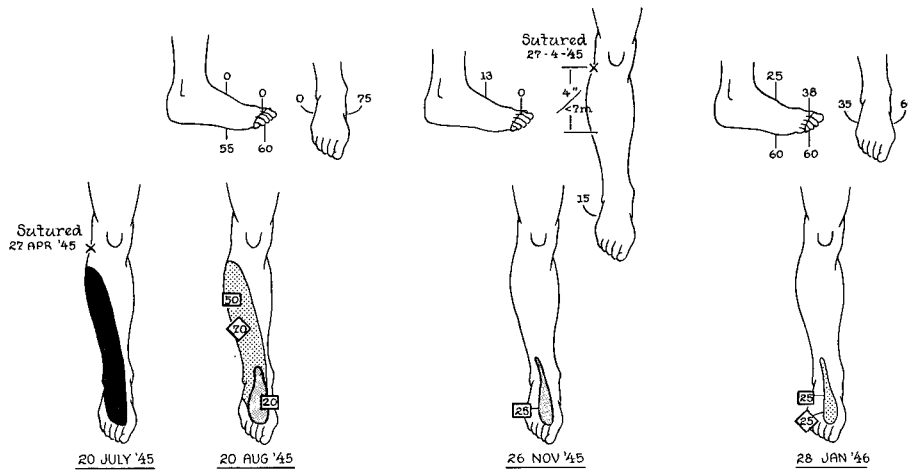

FIGURE 124.—Graphic record of patient with partial interruption of right common peroneal nerve, managed by suture. There has been satisfactory return of sensory and motor function within the usual time limits.

Progress of motor reinnervation was on time in both tibial and peroneal nerves, with the exception of the long and short peroneal muscles, which are often delayed. However, this did not much impair the gait. The shrinking analgesia and anesthesia are due to overlap only. The distance from the lesion to the foot is 19 inches, and no real improvement could be expected until 1947.

Patient had additional penetrating wounds of right upper arm and chest with hemothorax. Air transport nevertheless permitted nerve suture in Cushing General Hospital 10 weeks after injury on Okinawa.

Case 14. Injury of right common peroneal nerve

28 Feb. 1945. Wounded by shell fragments in popliteal space with complete paralysis of right common peroneal nerve (fig. 124).

27 Apr. 1945. Exploration in which three-fourths of nerve was found interrupted 1 inch above bifurcation into superficial and deep branches. No motor response on electrical stimulation but sensory response from preserved filament. Suture (overseas) of interrupted bundles and inclusion in preformed tantalum cuff.

20 July 1945. Complete motor and sensory paralysis in common peroneal.

20 Aug. 1945. Complete motor paralysis. Beginning return of sensation in lateral sural and common peroneal distribution.

26 Nov. 1945. Beginning return of motor function in ant. tibial and peroneal muscles (4 7/8 m.), not yet in toe extensors. Hypalgesia, anesthesia in deep peroneal distribution. The degree of motor return suggests that function began before present examination; that is, within expected time.

28 Jan. 1946. Good progress in motor and sensory improvement. Has worked for last 5 months as projectionist in movie theater without more difficulties than early fatigue. Able to walk 2 miles without brace.

Summary.—Complete interruption of motor fibers and partial interruption of sensory in common peroneal nerve with suture and return of motor function, as well as good sensory return.

CHAPTER XIV

Anatomic Approaches to the More Commonly Injured Peripheral Nerves

Warner Wells, M.D., Frederick M. Owens, M.D., and Francis A. Echlin, M.D.

An injured nerve that fails to recover spontaneously must be explored, for its physiologic continuity is interrupted by constriction, scar, or severance. The success of the operation and the ultimate result are as dependent on a correct anatomic approach as on a correct suture technique. The purpose of this chapter, therefore, is to present methods of approach to the more commonly injured peripheral nerves based on the anatomy of that portion of the extremity involved.

The techniques presented are an outgrowth of an experience in the handling of over 3,000 peripheral nerve injuries at McCloskey General Hospital, Temple, Tex., in World War II. No claim is made to originality. With the exception of a greater awareness of the importance of flexion creases, nothing fundamentally new was added in World War II to the descriptions of Stookey¹ and others published after World War I.

The procedures described are based on fundamental principles of surgical anatomy, on the unwritten store of surgical knowledge, and on the writings of those pioneers in this field who created the obligation to do nerve surgery through their studies in anatomy, physiology, and surgery. The references give credit only to those most immediately concerned. There are many more. It is hoped that the techniques subscribed to in World War II will be improved as other surgeons, faced with the same problems but equipped with new tools, bring to bear on them their ingenuity and their imagination.

HISTORICAL NOTE

In an essay on the early history of practical anatomy, Keen² made the following reference to Galen (b. 131 A.D.): "Surgeons, however, not infrequently have been allowed to test operations on criminals, who were pardoned if they survived. Galen thus operated in cases of nerve wounds * * *."

From his experience, Galen drew certain conclusions, as follows:

1. Section of a nerve produced paralysis in the region it supplied.

¹ Stookey, Byron: *Surgical and Mechanical Treatment of Peripheral Nerves*. Philadelphia and London: W. B. Saunders Co., 1922.

² Keen, William Williams: *The Early History of Practical Anatomy. In Addresses and Other Papers*. Philadelphia and London: W. B. Saunders Co., 1905, pp. 1-40.

2. This paralysis was incurable because nature was powerless to effect regeneration of nerves.

This idea of Galen's traversed the Middle Ages, Guy de Chauliac in the 14th century to the contrary, and it was not until the year 1776 that Cruikshank³ contested Galen's doctrine by stating that paralysis was not permanent after nerve section but that regeneration and resumption of function occurred. Cruikshank reached his conclusions after observing regeneration in the unsutured pneumogastrics and vagi of the dog after their deliberate severance. His study, however, was not reported until 1795.

Perhaps Druitt,⁴ in 1852, was drawing on Cruikshank's observations when he stated that, following complete nerve division, the nerve will readily unite in the same manner as bone or tendon, and sensibility and motion will return.

This idea of regeneration without suture has threaded its way through the literature up to the present day. Ballingall,⁵ in 1830, did, however, express a skeptical note when he stated: "The bulbous ends of a nerve which had not united have been cut out, but without avail."

Nerve surgery is born of war. Interest in it waxes during periods of hostility and wanes during the intervals of peace. For their knowledge of peripheral surgery, neurosurgeons are chiefly indebted to surgeons faced with the problem in military life. This was especially true in the Civil War, the Sino-Japanese War, and the First World War.

Billroth,⁶ in 1859, published a historical monograph on the nature and treatment of gunshot wounds, but he did not mention nerve injuries. Billings' Civil War journal describes fractures and amputations but makes no reference to nerve wounds.⁷

Philadelphia saw the opening, in 1863, of the Christian Street Hospital and later the Turner's Lane Hospital, successively devoted to the diseases and injuries of the nervous system, and probably the first Army hospitals in this country devoted exclusively to a specialty. To these hospitals went S. W. Mitchell, G. R. Morehouse, and W. W. Keen. Out of their experience they published, in 1864, a book, the first of its kind, on gunshot wounds and other injuries of nerves.⁸ Nerve surgery is not mentioned, although hope is expressed that prostheses may benefit paralyzed extremities.

³ Cruikshank, W.: *Experiments on the Nerves, Particularly on Their Reproduction; and the Spinal Marrow of Living Animals*. Philosoph. Tr. Roy. Soc. London, 85: 512-519, 1795.

⁴ Druitt, R.: *In The Principles of Surgery*, by James Miller. Third American from second and enlarged Edinburgh edition, revised with additions by F. W. Sargent. Philadelphia: Blanchard and Lea, 1852.

⁵ Ballingall, George: *Introductory Lectures to a Course of Military Surgery*, delivered in the University of Edinburgh. Edinburgh: A. Black, 1830.

⁶ Billroth, Theodor: *Historical Studies on the Nature and Treatment of Gunshot Wounds From the Fifteenth Century to the Present Time*. Berlin: 1859. Translated by C. P. Rhoads. Yale J. Biol. & Med. 4: 3-36, October 1931; 4: 119-148, December 1931; 4: 225-258, January 1932.

⁷ Garrison, Fielding H.: *John Shaw Billings; A Memoir*. New York: G. P. Putnam's Sons, 1915.

⁸ Mitchell, S. Weir, Morehouse, George R., and Keen, William W.: *Gunshot Wounds and Other Injuries of Nerves*. Philadelphia: J. B. Lippincott Co., 1864.

Mitchell described causalgia the same year, and 8 years later, in 1872, he wrote his classic text on injuries of nerves and their consequences.⁹ The next year saw the publication of Létiévant's work entitled "Traité des Sections Nerveuses,"¹⁰ which, despite its emphasis on neurectomy, did employ the physiologic principles underlying the experiments of Waller, Phillippeaux, and Vulpian.

Baudens, a French Army surgeon, serving with the colonial forces in Algiers, is credited with performing the first nerve suture; in 1836, he sutured the median and ulnar nerves in the axilla by approximating adjacent tissues. When the patient died a few days later, the ends were found to have separated. Nélaton and Laugier each performed nerve suture in 1864, and each claimed recovery within a few days of operation. Six more instances of nerve suture were recorded before 1870.

Nerve surgery did not pose a real problem until 1867, when Lister¹¹ introduced "systematic and scientific antiseptics and asepsis for the treatment of wounds and the performance of surgical operations." Lister's work was based on Pasteur's experiments. When it became possible to salvage, rather than amputate, badly wounded extremities, existing nerve injuries and their treatment became significant. Waller's theory of nerve degeneration, advanced in 1852, then gave the physiologic basis for nerve suture.

By 1893, in an analysis of the collected records of 84 primary sutures, Howell and Huber¹² stated: "The prognosis of cases of 'primary nerve suture' is very favorable; in all probability function will be restored either completely or partially."

Out of the First World War came careful and scholarly works on the management of nerve wounds by Tinel¹³ in 1918; Benisty¹⁴ in 1918; Stookey in 1922; Platt and Bristow¹⁵ in 1924; the section on neurosurgery in *The Medical Department of the U.S. Army in the World War* in 1927;¹⁶ and Pollock and Davis¹⁷ text in 1933. Bunnell's¹⁸ book on the surgery of the

⁹ Mitchell, S. Weir: *Injuries of Nerves and Their Consequences*. Philadelphia: J. B. Lippincott Co., 1872.

¹⁰ Létiévant, J. J. E.: *Traité des Sections Nerveuses*. Paris: J. B. Ballière et Fils, 1873.

¹¹ Lister, J.: On the Antiseptic Principle in the Practice of Surgery. A paper read before the British Medical Association in Dublin on August 9, 1867. *In* the *Collected Papers of Baron Joseph Lister*. Oxford at the Clarendon Press, 1909, vol. II, pp. 37-46.

¹² Howell, W. H., and Huber, G. C.: A Physiological, Histological, and Clinical Study of the Degeneration and Regeneration in Peripheral Nerve Fibres After Severance of Their Connections With the Nerve Centres III. *Critical Résumé of Surgical Cases of Primary and Secondary Suture*. *J. Physiol.* 14: 1-51, 1893.

¹³ Tinel, J.: *Nerve Wounds. Symptomatology of Peripheral Nerve Lesions Caused by War Wounds*. New York: William Wood & Co., 1918.

¹⁴ Benisty, A.: *Treatment and Repair of Nerve Lesions*, edited by E. Farquhar Buzzard. London: University of London Press Ltd., 1918.

¹⁵ Platt, H., and Bristow, W. R.: *The Remote Results of Operations for Injuries of the Peripheral Nerves*. *Brit. J. Surg.* 11: 535-567, January 1924.

¹⁶ *The Medical Department of the United States Army in the World War*. Washington: Government Printing Office, 1927, vol. XI, pt. 1, pp. 1081-1283.

¹⁷ Pollock, Lewis J. and Davis, Loyal: *Peripheral Nerve Injuries*. Hoeber's Surgical Monographs. New York: Paul B. Hoeber, Inc., 1933.

¹⁸ Bunnell, Sterling: *Surgery of the Hand*. Philadelphia: J. B. Lippincott Co., 1944.

hand, published in 1944, is a classic, not only for its treatment of nerve injuries, but for all phases of reconstructive surgery in the upper extremity.¹⁹

GENERAL CONSIDERATIONS

Certain general considerations are important if the surgeon is to combine good judgment with technical skill.

The extremity must be considered as a whole, with the recollection that the arm is but a vehicle to support and provide range of motion for the prehensile organ of sense, the hand, and that the foot is a hinged platform adapted to the locomotor function of the leg. Skin, bone, muscles, tendons, blood vessels, and nerves must be appraised collectively if the best functional result is to be obtained.

Bunnell summarizes the problem as follows: "Usually in the same traumatized limb with flexion contracture, injury to tendons, bones, joints, and nerves, we must combine plastic, orthopedic, and neurologic surgery. As the problem is composite, the surgeon must also be. It is impractical for three specialists to work together or in series. There is no shortcut. The surgeon must face the situation and equip himself to handle any and all of the tissues in a limb."

There are two rules to be followed with respect to incision: (1) Excision of the skin and subcutaneous tissue scar as part of the planned incision, and (2) delineation of the incision to conform to the course of the nerve and possible extension in such a manner as to avoid contractures. Straight lines should be avoided; flexion creases must not be crossed transversely or in a straight line, and the linear course of lymphatics and blood vessels must be respected. Sharp dissection to explore the injured nerve is preferred to blunt or scissors dissection. The plane of dissection should always be in a direction parallel with the axis of the extremity, for all important vascular, nervous, muscular, and tendinous structures are disposed in a linear direction. Transverse dissection cuts rather than separates. Moreover, longitudinal dissection is less likely to injure the collateral blood supply where the normal blood flow has been compromised.

The proximity of nerves to blood vessels should keep the operator ever alert to the possibility of aneurysm or arteriovenous fistula even though the condition is not diagnosed preoperatively.

The exploratory wound must be made large enough to expose normal tissue above and below the lesion, to make it easier to follow the nerve into areas in which scarring and distortion are considerable.

With few exceptions, the peripheral nerves have a meager intrinsic blood supply. Their nutritional requirements are largely supplied from small vessels that enter through the loose connective tissue investing them.

¹⁹ The late Dr. Sterling Bunnell served as the special consultant in hand surgery to the Secretary of War during World War II and also as editor for "Medical Department, United States Army. Surgery in World War II. Hand Surgery." Washington: U.S. Government Printing Office, 1955.

If, therefore, a nerve is freed for a considerable distance, it becomes, in effect, a nerve graft. Care should be taken, when a nerve is freed, to leave it attached at intervals to its vascular connective tissue investment.

The mechanical difficulty experienced in obtaining end-to-end apposition of the proximal and distal nerve stumps when large defects exist is perhaps the chief obstacle to successful nerve suture. The technical maneuvers employed, which are discussed under the respective nerves, represent perhaps the greatest contribution to nerve suture. Platt and Bristow, after World War I, enumerated them in the order of their importance, as follows:

1. Wide anatomical exposure with free mobilization of the nerve.
2. Positioning of the extremity to afford maximum relaxation of the nerve.
3. Transplantation of the nerve to a new position that will shorten its course.
4. Stripping of the nerve branches in the proximal segment or, in very occasional instances, the sacrificing of a branch to allow downward displacement of the nerve trunk.
5. Bone shortening, in the case of brachial plexus lesions in which the clavicle is shortened or allowed to override and in which nonunion of fractures requires the trimming of bone ends.
6. Preoperative exercises designed to stretch the nerve upward from its site of attachment to the wound scar.

With increasing experience, the surgeon will find that the use of these expedients for gaining length will decrease the number of lesions ordinarily considered to be irreparable by direct suture.

THE BRACHIAL PLEXUS

General Anatomy

The brachial plexus is formed within the neck from the interlacing fusion of the anterior primary divisions of the fifth, sixth, seventh, and eighth cervical nerves and the first thoracic nerve, plus contributory twigs from the fourth cervical and second thoracic nerves. Accurate localization of the level of a nerve lesion requires that it be considered from the standpoint of its components, including the nerve roots that form it and its own trunks, divisions, cords, and main branches (fig. 125).

Components.—The lower four cervical nerves, after crossing behind the vertebral artery and between the anterior and posterior parts of the intertransverse muscles, enter the posterior triangle of the neck between the contiguous borders of the anterior and middle scalene muscles (fig. 126). The anterior primary division of the first thoracic nerve divides into two branches, the smaller of which enters the first intercostal space as the first intercostal nerve. The larger branch, after receiving a twig from the second thoracic nerve, passes in front of the neck of the first rib and behind the

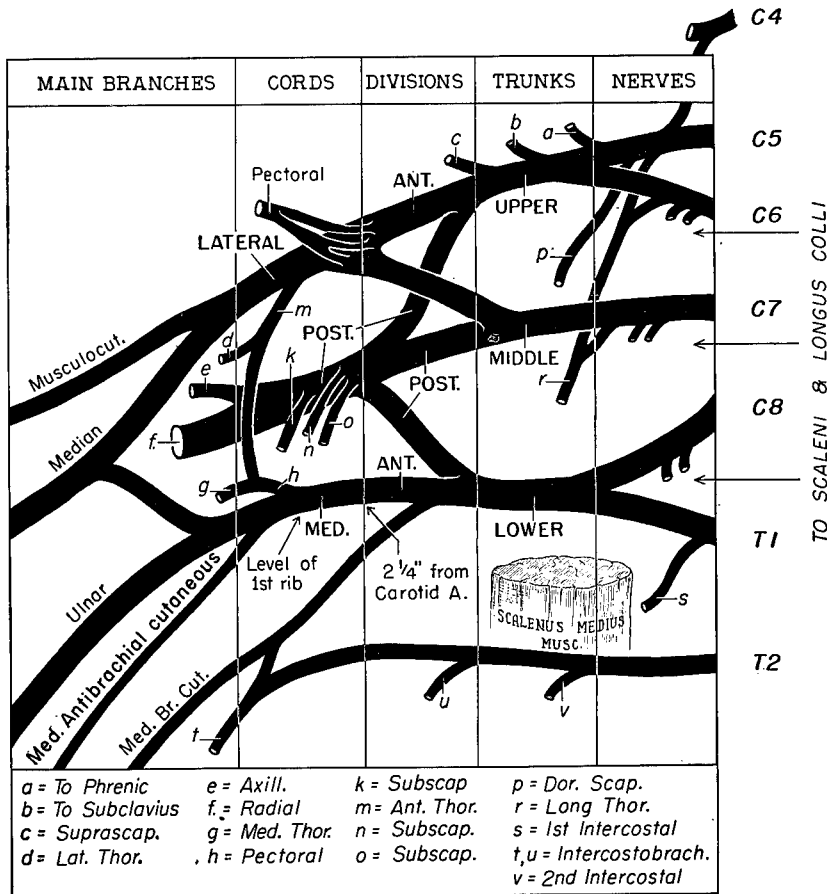

FIGURE 125.—Schematic view of brachial plexus, its roots components, and its main branches (modified from Bunnell).

apex of the pleural sac. It continues upward and laterally into the posterior cervical triangle, where, on the anterior surface of the scalenus medius, it combines with the other nerves in the formation of the brachial plexus.

Three trunks are formed on the anterior surface of the scalenus medius muscle to comprise the first portion of the brachial plexus. The fifth and sixth cervical nerves fuse to form the upper trunk. The seventh cervical, which is the largest nerve entering the plexus, crosses the muscle independently as the middle trunk. The eighth cervical and first thoracic nerves form the lower trunk.

The upper, middle, and lower trunks each divide into anterior and posterior portions to form the second portion of the brachial plexus.

The third portion of the brachial plexus begins near the first rib. It consists of the lateral, medial, and posterior cords, which are so called because

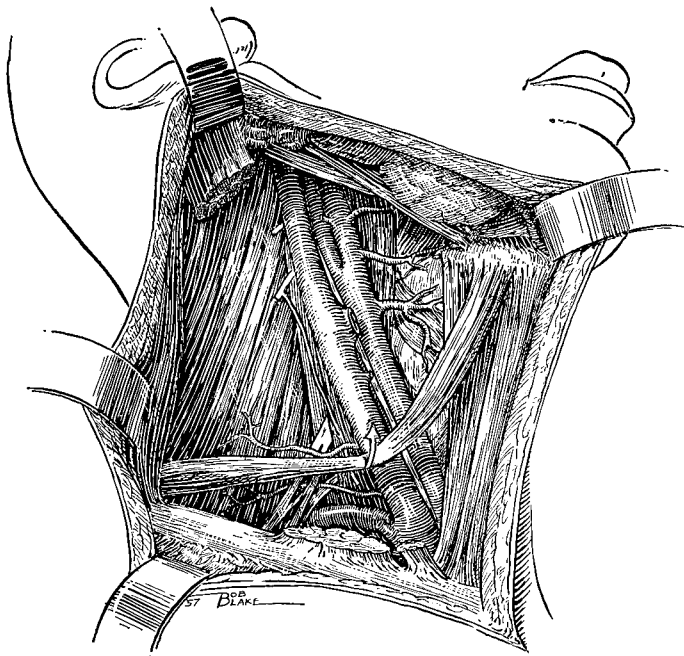

FIGURE 126.—Supraclavicular exposure of brachial plexus.

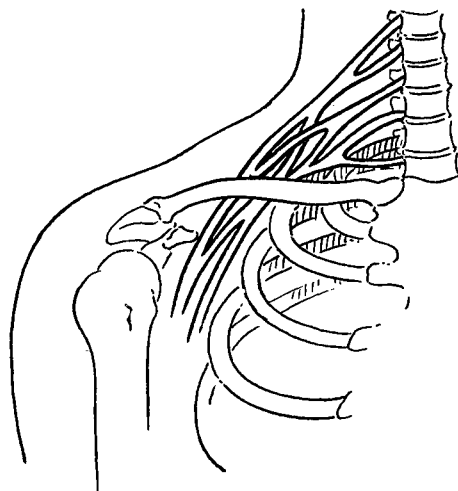

FIGURE 127.—Relation of brachial plexus to first rib and clavicle.

of their relation to the axillary artery. The lateral cord is formed by the anterior branches of the upper and middle trunk, the medial cord by the anterior branch of the lower trunk, and the posterior cord by the posterior branches of all three trunks. The lateral cord controls all flexor and pronator motions of the upper extremity, and the posterior cord controls all extensor and supinator motions. The medial cord controls the flexor muscles on the ulnar side of the forearm and the intrinsic muscles of the hand.

There are five main terminal branches in the brachial plexus, the musculocutaneous, radial, axillary, median, and ulnar nerves. The lateral cord branches into the musculocutaneous for flexing the elbow and into the upper branch of the median nerve for the sensory distribution of that branch and for flexion of the wrist and pronation. The posterior cord branches to form the axillary nerve for abduction of the shoulder and the radial nerve for extension of the forearm, wrist, and fingers. The medial cord branches to form (1) the lower branch of the median nerve, which supplies the flexors of the digits, and (2) the ulnar nerve, which supplies the flexors on the ulnar side of the forearm and all the intrinsic muscles of the hand except the thenar muscles and the first two lumbricales. Two minor terminal branches which arise from the medial cord, the medial antebrachial cutaneous and the medial brachial cutaneous nerves, supply sensation down the medial side of the arm.

Relations.—The brachial plexus begins in the posterior cervical triangle, which is bounded anteriorly by the sternocleidomastoid, posteriorly by the trapezius, and inferiorly by the clavicle (fig. 126). It extends from the lateral border of the scalenus anterior, from beneath which the roots of its constituent nerves appear, through the neck, and beneath the clavicle into the axilla. Here, each of its three cords divides into terminal branches near the lower border of the pectoralis minor.

In the posterior triangle, the brachial plexus is bounded posteriorly by the scalenus medius, which it crosses, and anteriorly by the skin, superficial fascia, platysma, supraclavicular branches of the cervical plexus, and the deep fascia. The levator scapulae and the trapezius muscles lie laterally.

In the root of the neck, the lower border of the plexus is in relation with the pleura, the first rib, and the third part of the subclavian artery (fig. 127). It is crossed by the lower part of the jugular vein, by the nerve to the subclavius, by the transverse cervical and scapular veins, by the posterior belly of the omohyoid muscle, and by the transverse cervical artery. In the axilla, the cords of the brachial plexus are arranged around the axillary artery (fig. 128). The posterior cord lies dorsally, the lateral cord laterally, and the medial cord medially to the artery. The medial cord is overlapped anteriorly by the axillary vein (fig. 129).

The surgeon will be better oriented, and a lesion within the plexus can be more accurately placed, if the nerve branches which arise within the

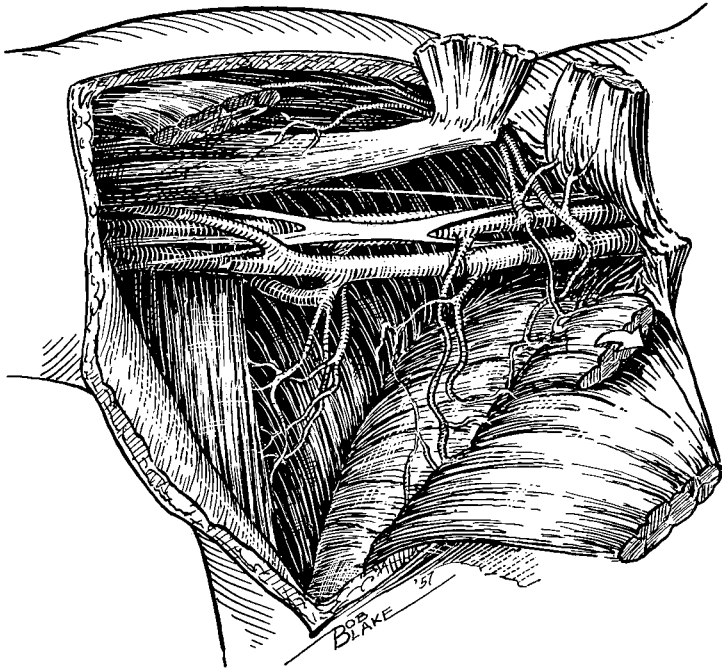

FIGURE 128.—Relation of cords of brachial plexus to axillary artery.

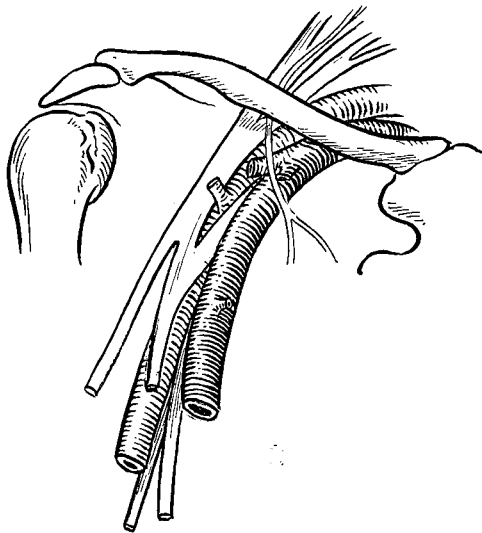

FIGURE 129.—Relation between medial cord of brachial plexus and axillary vein.

plexus are grouped according to the components from which they arise (fig. 125), as follows:

1. Branches from the nerve roots forming the plexus. Twigs supplying the scaleni and longus colli muscles arise from the lower three or four cervical nerves immediately after their exit from the respective intervertebral foramina. The dorsal scapular nerve arises primarily from the fifth cervical nerve and crosses the scalenus medius parallel with, and below, the spinal accessory nerve to the anterior border of the levator scapulae. Here it disappears, to supply the rhomboids. The long thoracic nerve (external respiratory nerve of Bell) arises by three roots from the fifth, sixth, and seventh cervical nerves, respectively, the two upper roots traversing the scalenus medius and the lower root crossing it anteriorly before merging behind the brachial plexus. The nerve runs downward behind the first stage of the axillary artery, to supply the serratus anterior muscle. A twig to the phrenic arises from the fifth cervical nerve. The first intercostal nerve arises from the first thoracic nerve.

The sympathetic innervation to the upper extremity enters the brachial plexus near the inner border of the scalenus medius before the nerves fuse into the trunks. Because of its importance, both diagnostically and surgically, it is necessary to consider the sympathetic supply at this point. The fifth and sixth cervical nerves each receive a gray ramus communicans from the middle cervical sympathetic ganglion, and the seventh and eighth nerves are supplied by the inferior cervical sympathetic ganglion. Two gray rami communicans from the first thoracic ganglion supply the first thoracic nerve.

2. Branches from the trunks. The suprascapular nerve, the first conspicuously large nerve to leave the brachial plexus superiorly, arises from the upper trunk near the lateral border of the scalenus medius and runs across the posterior cervical triangle on the upper border of the posterior belly of the omohyoid muscle to supply the supraspinatus and infraspinatus muscles. The nerve to the subclavius makes its exit from the upper trunk medial to the suprascapular nerve.

3. Branches from the cords. The lateral and medial anterior thoracic nerves arise from the lateral and medial cords, respectively, and pass anteriorly to supply the pectoralis major and minor muscles. The subscapular nerves, three in number, arise from the posterior cord as the upper, middle, and lower nerves and pass posterior to the plexus to supply the subscapularis, latissimus dorsi, and teres major muscles, respectively. The medial brachial cutaneous and medial antebrachial cutaneous nerves arise from the medial cord to supply, in succession, the medial surface of the arm and forearm.

4. Main branches from the plexus. These nerves will be considered under separate headings.

Summary.—The brachial plexus may be considered as arising from five nerves and terminating in five nerves. Intervening are three trunks and three cords connected by three anterior and three posterior divisions. These

divisions serve to separate the flexor and extensor nerve fibers which enter the upper extremity. Fairly well defined and consistent nerve branches emerge successively from different levels. These nerve branches, which are the roots, the trunks, and the cords, together with the tissues which they supply, serve as a means of identifying the level of a brachial plexus lesion. Of additional aid is the knowledge that the lateral cord subserves all flexor and pronator motions, the posterior cord all extensor and supinator motions, and the medial cord the flexor muscles on the extreme ulnar border of the forearm and the intrinsic muscles of the hand.

The surgeon will be better oriented at the operating table if he keeps in mind that the trunks are formed on the anterior surface of the scalenus medius muscle and that the cords begin at or near the level of the first rib.

Surface Anatomy

The brachial plexus itself has no direct superficial landmarks. There is no difficulty, however, in localizing it accurately because of its relation to easily seen and palpated superficial landmarks in the neck and axilla, as follows:

1. With the head turned to one side, the sternocleidomastoid muscle of the opposite side is thrown into strong relief.
2. The brachial plexus can be palpated deep in the neck as it crosses the scalenus medius muscle immediately lateral to the middle third of the sternocleidomastoid muscle.
3. The pulsation of the carotid artery can be felt just medial to the plexus.
4. The cords of the plexus begin $2\frac{3}{4}$ inches lateral to this vessel.
5. The brachial plexus descends into the axilla beneath the middle third of the clavicle (fig. 129).
6. The axillary artery can be palpated in the axilla.
7. The lower ends of the cords and the beginnings of the terminal branches are disposed around this vessel (fig. 128).

Surgical Approach

Position.—The patient lies semirecumbent, with the head extended and turned to the side opposite the lesion. An arm board affixed to the table provides lateral support for the arm on the affected side. Preparation includes the neck, shoulder, anterior thorax, axilla, and the entire extremity. The arm is wrapped in sterile stockinet but is readily accessible whenever it is necessary to determine the effect of electrical stimulation. It is also left free for any change in position necessitated in the course of the procedure.

Exposure.—The supraclavicular portion of the brachial plexus is exposed through an incision that begins $1\frac{1}{2}$ inches lateral to the middle third of the sternocleidomastoid muscle and continues forward and downward toward

the sternoclavicular joint (fig. 130). Although this is not a collar incision, it closely follows the creases present when the head is in neutral position. If dissection below the clavicle proves necessary, the incision can be carried downward and laterally across the upper chest toward the axilla, in line with the course of the pectoral muscle. Deforming scars and keloid can thus be avoided.

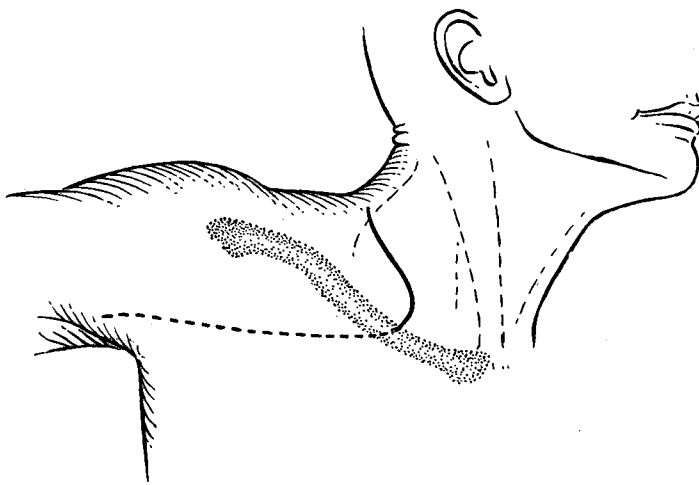

FIGURE 130.—Skin incision for exposure of brachial plexus.
Dotted line represents extension.

The platysma is divided and widely undermined. The external cervical fascia is incised lateral to the sternocleidomastoid, care being taken to avoid injury to the external jugular vein and supraclavicular branches of the cervical plexus. The sternocleidomastoid muscle is retracted medially. Incision of the deep fascia is then necessary to allow retraction of the omohyoid muscle and exposure of the brachial plexus. The plexus stands out more prominently and is exposed more easily if it is kept under tension by abducting, extending, and externally rotating the arm.

The scalenus anticus muscle lies medially and just lateral to the internal jugular vein and carotid artery. The phrenic nerve crosses its anterior surface obliquely (fig. 126). The brachial plexus emerges from beneath its lateral border, crosses the scalenus medius, and runs obliquely downward and laterally to lie in relation with the subclavian artery near the root of the neck.

The topmost conspicuous nerve is the fifth cervical. The seventh cervical nerve is also recognized by its large size. The eighth cervical and first thoracic nerves are identified by their deep medial roots, which lie close to the innominate vein, subclavian artery, and apex of the pleura. The cords are well defined as the plexus crosses the first rib, and, from this point downward, the posterior cord is behind the artery.

If dissection must be prolonged below the clavicle, the incision is extended, as just described. The clavicle is severed in the middle in a dovetail manner, and its ends are separated. It is not usually necessary to cut the pectoralis major; lateral spread of its serrations from the breach in the clavicle is sufficient in most cases. It may or may not be necessary to divide the insertion of the pectoralis minor at the coracoid process (fig. 128).

If the brachial plexus lesion is infraclavicular, it may be exposed through the axillary incision employed for the radial nerve (p. 322) or through an incision parallel with the clavicle in front of the anterior axillary fold.

Exposure of the brachial plexus is a difficult and tedious procedure. The surgeon who undertakes it must possess an accurate knowledge of the regional anatomy as well as technical skill and judgment. When the injury has been severe, the scar will be large and the tissues distorted and brittle. It is essential that the injured area be approached from normal surroundings. Blind dissection could be fatal or crippling. The threat of serious hemorrhage from large vessels is always present and must be anticipated to be avoided.

Methods of Gaining Length

The brachial plexus is under greatest tension when the neck is extended, the head turned and inclined to the opposite shoulder, the arm extended and externally rotated, and the shoulder turned outward. Relaxation, on the contrary, is maximal when the neck is flexed, the head turned and inclined to the same side, the arm flexed and adducted, and the arm and shoulder internally rotated. Gaps in the plexus up to $2\frac{1}{4}$ to $2\frac{3}{4}$ inches can thus be overcome by the simple expedient of correct positioning. If great length is required, the nerves can be freed down into the arm and the clavicle made to override. Gaps up to 4 to $4\frac{3}{4}$ inches can thus be overcome.

Closure of the Wound

Severed muscles or tendons are reapproximated, and the subcutaneous tissues and skin are closed separately. Loose approximation of the deep tissues will eliminate dead space and lessen the chances of bleeding from raw surfaces. If the clavicle has been divided, it will heal without internal fixation if the dovetailed ends are approximated and the arm and shoulder properly splinted.

THE MUSCULOCUTANEOUS NERVE

General Anatomy

The musculocutaneous nerve, one of the two terminal branches of the lateral cord of the brachial plexus, is composed chiefly of fibers derived from

the fifth and sixth cervical nerves. In about half of all cases, it also receives fibers from the fourth and seventh cervical nerves. It originates deep in the axilla, lateral to the axillary artery. It innervates the coracobrachialis, the biceps, and the brachialis muscles, as well as the humerus and the elbow joint. It also supplies sensation to the anterolateral and posterior surfaces of the forearm (fig. 131).

After a short course in the axillary fossa lateral to the axillary artery, the musculocutaneous nerve leaves the artery to pierce the substance of the coracobrachialis muscle. Branches to this muscle are given off just before the nerve enters it. In some instances, however, the nerve supply to the coracobrachialis muscle comes directly from the seventh cervical nerve, the musculocutaneous nerve not passing through the brachial plexus.

The musculocutaneous nerve then runs obliquely and laterally down the arm between the biceps and brachialis muscles, which it supplies as it descends. It also gives off twigs to the humerus and the nutrient artery. Its deep terminal branch descends to provide the chief nerve supply to the elbow.

The lateral antebrachial cutaneous nerve begins below the branch to the brachialis muscle and descends between this muscle and the biceps to the anterolateral aspect of the elbow. Here it penetrates the deep fascia to become superficial. It then divides into anterior and posterior branches, which supply the anterolateral, posterior, and posterolateral aspects of the forearm. The anterior branch extends as far as the thenar eminence, whose midportion it supplies.

Only the axillary nerve has a shorter course proximal to its sphere of innervation than the musculocutaneous nerve. Because of its short main trunk, the latter nerve was therefore seldom the seat of isolated nerve injury, while its close proximity to the brachial plexus and the muscles which the plexus innervates accounted for the frequent association of injuries of these structures and the musculocutaneous nerve.

Surface Anatomy

The course of the musculocutaneous nerve in the arm can be visualized by drawing a line from the coracoid process to the lateral epicondyle of the humerus. In its anteroposterior position, the nerve is in a plane with the medial and lateral bicipital sulci. The two branches of the lateral antebrachial cutaneous nerve in the forearm are on each side of a line drawn from the lateral epicondyle of the humerus to the thenar eminence.

Surgical Approach

Position.—The patient lies supine, with the shoulder elevated and the arm abducted 90° on the affected side. The elbow is left free to move, and the arm and axilla are included in the sterile field.

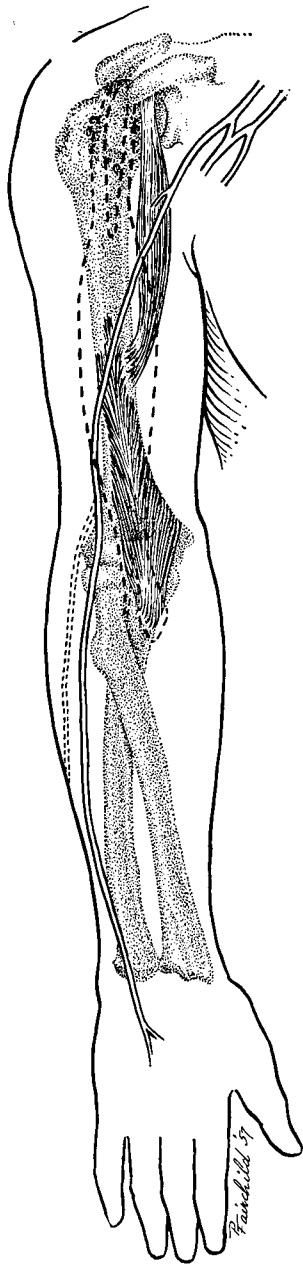

FIGURE 131.—Surgical anatomy of musculocutaneous nerve.

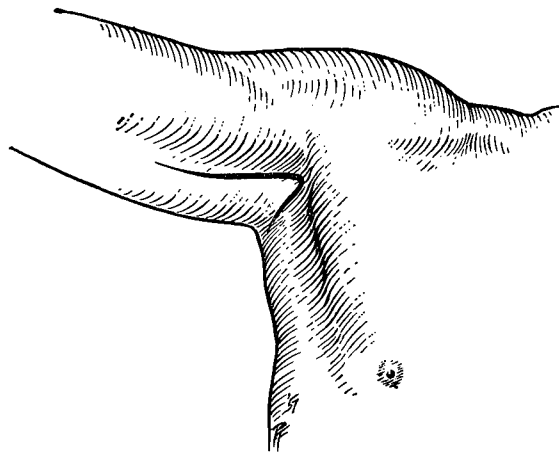

FIGURE 132.—Skin incision for exposure of musculocutaneous nerve.

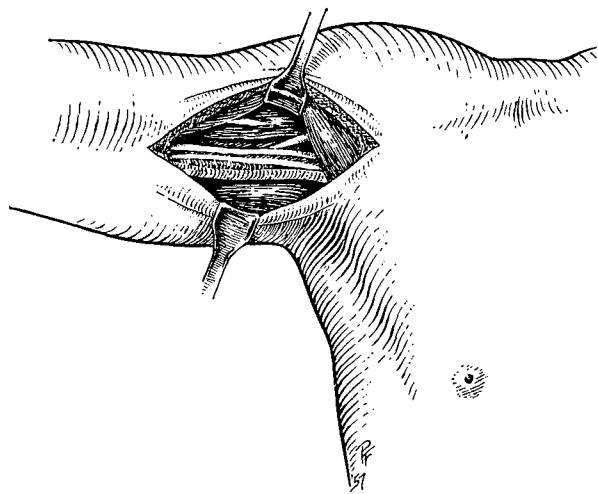

FIGURE 133.—Surgical exposure of musculocutaneous nerve.

Exposure.—A curved incision, with its center over the medial bicipital sulcus in the upper arm, is projected upward to the lower border of the pectoralis major muscle at the point at which it crosses the axilla. It is then continued downward across the axilla to the border of the latissimus dorsi muscle, in line with the transverse skin crease (fig. 132). Branches of the medial brachial cutaneous nerve lie in the subcutaneous tissue.

This incision affords adequate exposure of the brachial plexus in the lower axilla and permits any necessary extension in the arm.

In the upper arm, the fascia investing the coracobrachialis is incised, and the undersurface of the muscle is followed upward toward the coracoid process. The musculocutaneous nerve will be seen between this muscle and the neurovascular bundle lateral to the axillary artery (fig. 133). The nerve pierces the coracobrachialis muscle just opposite the lateral third of the pectoralis minor muscle. Branches to the coracobrachialis emerge at this point. Just below the coracoid process, the musculocutaneous nerve becomes part of the lateral cord of the brachial plexus.

Within the upper and middle thirds of the arm, the musculocutaneous nerve lies between the biceps and the brachialis muscles. The motor branches to these muscles arise soon after the nerve leaves the substance of the coracobrachialis muscle. The terminal lateral cutaneous branch can be seen descending obliquely and laterally between the biceps and brachialis muscles toward the lateral epicondyle of the humerus.

The musculocutaneous nerve and its branches in the forearm were seldom deliberately explored unless one of them was the site of a painful neuroma.

Methods of Gaining Length

The musculocutaneous nerve is under greatest tension when the head is inclined to the side opposite the lesion; the shoulder and arm are externally rotated; the arm is abducted; and the forearm is extended, with stretching of the biceps and consequent traction on the nerve. Maximum relaxation is obtained when the head is inclined to the side of the lesion, the arm and shoulder are internally rotated, the arm is adducted, and the forearm is flexed at the elbow. Positioning is thus used to advantage when defects up to 2 inches must be overcome. Because the normal course of the musculocutaneous nerve is in a straight line with the muscles it innervates, nothing is gained by trying to reroute it.

Closure of the Wound

Closure of the wound consists simply of reapproximation of deep fascia, subcutaneous tissues, and skin.

THE AXILLARY NERVE

General Anatomy

The axillary nerve arises from the posterior cord of the brachial plexus. It is composed primarily of fibers from the ventral division of the fifth and sixth cervical roots. It runs in the sheath of the radial nerve, to form the posterior cord of the brachial plexus. As it leaves the radial nerve, it passes over the inferolateral third of the subscapularis muscle.

After the axillary nerve runs behind the axillary artery, it turns posteriorly across the inferior border of the subscapularis muscle to enter the quadrilateral space of Velpeau behind the surgical neck of the humerus. It winds around the surgical neck of the humerus and courses forward and laterally through the deltoid muscle, by which it is covered. Motor fibers are supplied to the teres minor and the deltoid muscles, while sensory fibers supply the skin of the lateral aspect of the shoulder.

Surface Anatomy

The axillary nerve is situated so deeply that it cannot be palpated at any point. Posteriorly, it can be located in the space bounded above by the teres minor, laterally by the humerus, and inferomedially by the long head of the triceps muscle.

Surgical Approach

Like the musculocutaneous nerve, the axillary nerve was seldom injured independently, both because of its short course and because of its intimate relation to the brachial plexus. Injury to the axillary nerve in its muscular bed was so frequently associated with crippling injuries to the shoulder joint and deltoid muscle that only the exceptional patient could be benefited by surgery.

Because of its intimate relation to the brachial plexus, the surgical anatomy of that structure must be taken into consideration when axillary exposure of the axillary nerve is necessary.

Exposure in the axilla.—The patient lies supine, with the arm abducted and externally rotated. The shoulder is elevated by placing a small, hard pillow beneath the medial portion of the scapula. The entire arm is so draped that it can be moved freely.

The incision is made transversely across the axilla, beginning at the lower third of the tendinous portion of the pectoralis major muscle and extending posteriorly along the skin lines to the angle between the latissimus dorsi and triceps muscles (fig. 134).

The deep fascia is divided, and the pectoralis major is retracted upward. This maneuver exposes the neurovascular bundle and the axillary nerve, which, with the radial nerve, lies posterior to the axillary artery. The

axillary nerve usually arises from the medial aspect of the radial nerve (fig. 135). It extends distally on the subscapularis muscle to enter the quadrilateral space just above the tendon of the latissimus dorsi muscle. If exposure must extend farther in a proximal direction, the tendinous portion of the pectoralis major muscle may be divided; if this is necessary, the muscle must be carefully resutured when the wound is closed.

Considerable exposure can be gained from the approach just described, including exposure of the nerve in the quadrilateral space.

Exposure at the surgical neck of the humerus.—The distal portion of the axillary nerve can be exposed behind the humerus by employing a posterior extension of the axillary incision just described. The patient lies on the unaffected side, with the arm flexed across the chest. The line of incision (fig. 136) extends from the tip of the acromion process to the posterior axillary line at the medial border of the long head of the triceps muscle. The plane of dissection passes between the posterior border of the deltoid muscle and the lateral border of the long head of the triceps. A layer of fascia between these muscles is divided, after which the nerve is exposed as it passes beneath the teres minor muscle. The motor branch to the teres minor muscle arises at this point, but the remainder of the motor branches originate as the nerve fans out beneath the deltoid muscle (fig. 137).

Injury to the nerve at the point at which it breaks up into its distal branches usually defies repair. In such cases, the freshly cut ends of the nerve bundles are implanted directly into the muscle. Irreparable injuries in this region can be overcome by arthrodesis of the shoulder joint, provided that the other muscles in the shoulder girdle are intact.

Methods of Gaining Length

The short course of the axillary nerve exterior to the muscles which it supplies precludes the bridging of any large gap. Relaxation is maximal with the shoulder elevated, the arm externally rotated, and the head inclined to that side.

THE RADIAL NERVE

General Anatomy

The radial (musculospiral) nerve contains fibers from the sixth, seventh, and eighth cervical nerves. It arises from the posterior cord of the brachial plexus and mediates all extension to the elbow, wrist, and digits except for the two distal joints of the fingers; these two joints are extended by the intrinsic muscles of the hand.

After its beginning at the lower border of the pectoralis minor, the radial nerve first traverses the axilla behind the axillary artery. Then it continues down the upper arm, between the humerus and the brachial artery

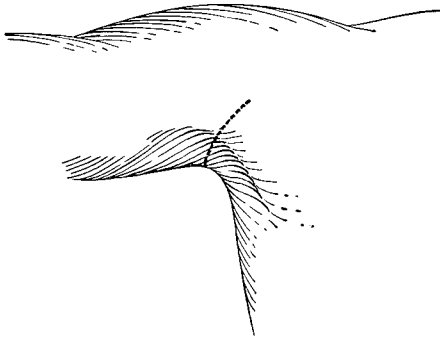

FIGURE 134.—Skin incision for exposure of axillary nerve.

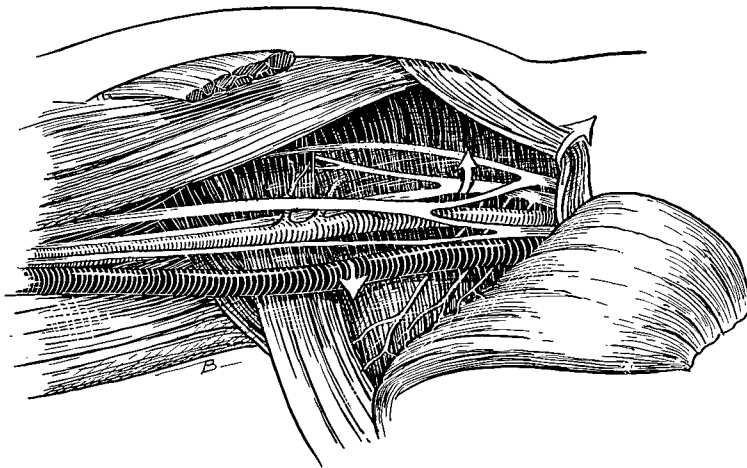

FIGURE 135.—Surgical anatomy of axillary space and exposure of axillary nerve.

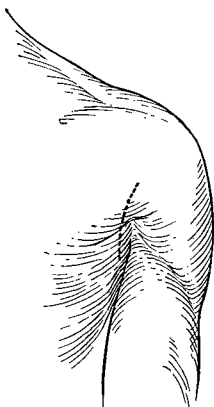

FIGURE 136.—Skin incision for exposure of distal portion of axillary nerve.

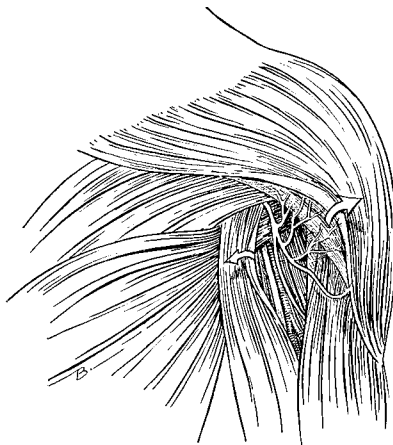

FIGURE 137.—Surgical anatomy of distal portion of axillary nerve.

(fig. 138). Near the middle of the arm, the radial nerve, with the profunda artery, passes obliquely behind the humerus through the musculospiral groove to the external aspect of the arm. Near the lower third of the arm, the nerve pierces the lateral intermuscular septum. Then, accompanied by an anterior terminal branch of the profunda artery, it descends between the brachioradialis and extensor carpi radialis longus to the elbow, where it divides into its terminal branches. These branches are the motor or deep radial and the sensory or superficial radial.

The superficial radial nerve courses downward, under cover of the brachioradialis muscle, to the middle third of the forearm, where it lies lateral to the radial artery. In the lower third of the forearm, it becomes superficial to the brachioradialis tendon. Then it perforates the deep fascia and descends along the radius to its terminal branches on the dorsum of the first three digits.

The deep radial nerve leaves its bed between the brachioradialis and extensor carpi radialis longus to pass through the substance of the supinator muscle. It then crosses the abductor pollicis longus, in company with the posterior interosseous artery, to become the dorsal interosseous nerve as it dips beneath the extensor pollicis longus. Accompanying the volar interosseous artery and lying on the interosseous membrane next to the radius, this nerve then descends through the groove for the extensor digitorum communis and the extensor indicis proprius to the wrist, where it ends in a gangliform enlargement which gives branches to the carpal articulation.

Branches in the arm.—Motor branches from the radial nerve to the medial and long heads of the triceps arise in the axilla. A sensory area behind the arm is supplied from that level by the posterior brachial cutaneous nerve. In the middle third of the arm, motor branches arise to the lateral and medial heads of the triceps and to the anconeus. A sensory branch, the dorsal antebrachial cutaneous nerve, also arises at this level. This nerve, through upper and lower branches, supplies the skin over the lower lateral and anterior aspect of the arm and the back of the forearm to the wrist (fig. 139). After the radial nerve has pierced the lateral intermuscular septum, motor branches are given off to the brachioradialis, the extensor carpi radialis longus, and the lateral portion of the brachialis. An articular filament passes to the elbow joint.

Branches in the forearm.—From above downward, the deep radial and the dorsal interosseous nerves supply the extensor carpi radialis brevis, supinator, brachioradialis, extensor digitorum communis, extensor digiti quinti proprius, extensor carpi ulnaris, extensor indicis proprius, and the extensor muscles of the thumb. The superficial radial nerve supplies sensation to the skin over the dorsum of the first three digits and the radiodorsal aspects of the hand.

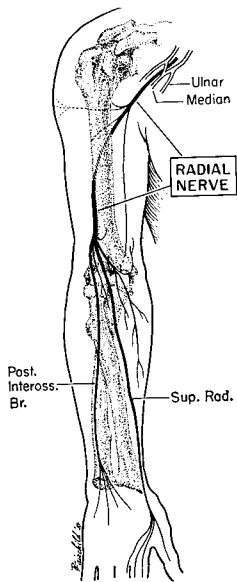

FIGURE 138.—Surgical anatomy of radial nerve.

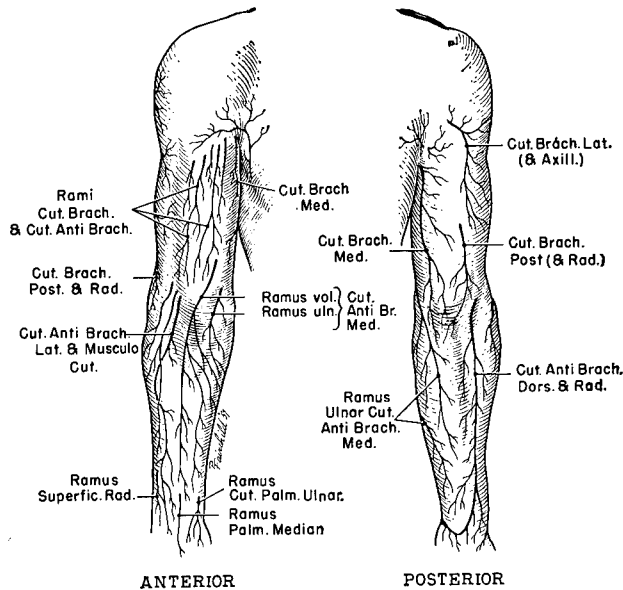

FIGURE 139.—Superficial cutaneous branches of radial nerve in upper extremity.

Surface Anatomy

Since the radial nerve lies behind the axillary artery in the axilla, its approximate position can be gaged by palpation of this vessel. In the upper arm, the nerve lies deep in the medial bicipital sulcus beneath the brachial artery. An oblique line drawn from the posterior axillary fold to a point approximately 1 inch below the insertion of the deltoid muscle will define the course of the nerve to the outside of the arm. From this point, the nerve trunk runs forward through the lateral bicipital sulcus to the front of the lateral epicondyle of the humerus. Here it divides into its deep and superficial branches.

The superficial branch of the radial nerve lies beneath the brachioradialis muscle to the lower forearm. Here the branch becomes superficial and continues downward, close to the radius, to the hand. The deep radial nerve leaves the anterolateral aspect of the elbow to follow the radius in a gentle spiral beneath the anteroexternal bulge of the brachioradialis and radial extensor muscles. In the lower forearm, the dorsal interosseous nerve descends to the wrist through the groove between the radius and ulna in which the common extensor tendons lie. A line drawn between the lateral condyle of the humerus to the tubercle of the radius generally corresponds to the course of the radial nerve in the forearm.

Surgical Approach

Positioning and preparation.—The patient lies supine on the operating table for all exposures of the radial nerve. Pillows or folded sheets are placed beneath the body to raise the affected extremity 45°. With proper draping, there are no lesions of the radial nerve which cannot be approached from this position.

The entire arm, axilla, and shoulder are prepared. The hand is encased in a sterile glove, and the extremity is wrapped in sterile stockinet. The arm is extended on an arm board, and drapes are so applied that the entire arm, axilla, and shoulder are in a sterile field. With such preparation and draping, the extremity is allowed complete range of motion, and any change in position necessary for fresh exposure or extension of the incision is easily accomplished.

Exposure in the axilla.—With the arm held upright (fig. 140), a gently curving incision is made in the groove between the biceps and deltoid and is extended posteriorly across the axilla to the lateral border of the latissimus dorsi. The lines of Langer are thus followed, and the crossing of flexion creases, which might later cause keloid or flexion contracture, is avoided. When the subcutaneous exposure is completed, care must be taken to avoid the intercostobrachial and thoracodorsal nerves.

In the center of the wound, between the short head of the biceps and the latissimus dorsi, is a fascia-encased neurovascular bundle which contains the lower reaches of the brachial plexus and the axillary artery and vein as they blend into their respective components in the arm. The radial nerve is on the opposite side of this bundle, behind either the axillary or the brachial artery. It can be identified as the largest nerve going into the arm (fig. 141).

If there is much scar tissue, its presence, together with the fragility of the large, thin-walled veins, imposes great caution on the surgeon. Tissue distortion may require identification of the posterior cord, from which the radial nerve arises, above the lesion, as well as of the radial nerve in the upper arm below the lesion. The posterior cord lies behind the axillary artery and gives rise to the axillary nerve, which can be identified by electrical stimulation. The radial nerve lies between the humerus and the brachial artery in the arm. The motor branches to the medial and long heads of the triceps which emerge from the radial nerve trunk at this level should be identified for suture if they are severed or for their protection if they are intact.

Closure of the incision in the axilla requires approximation only of the subcutaneous tissues and skin. This exposure requires no severance of muscular, tendinous, or retaining structures.

Exposure in the upper arm.—With the arm held upright (fig. 142), an oblique incision is made from the apex of the axilla downward and laterally to a point 1 inch below the insertion of the deltoid. The medial and lateral

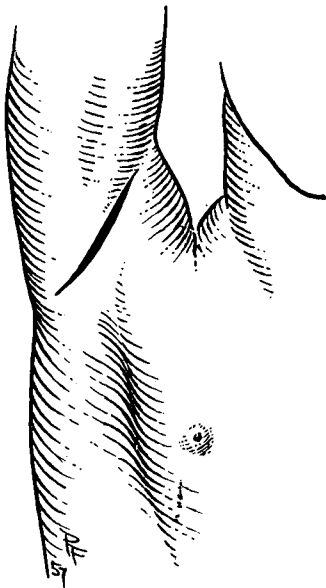

FIGURE 140.—Skin incision for exposure of proximal third of radial nerve.

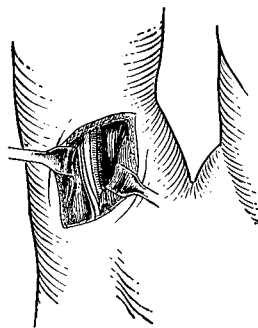

FIGURE 141.—Surgical exposure of axillary portion of radial nerve.

brachial cutaneous nerves are avoided. The medial intermuscular septum is incised at the upper limit of the wound, and the deep fascia is divided downward and laterally. The neuromuscular bundle, which contains the brachial artery and veins and the median, ulnar, radial, and medial antebrachial cutaneous nerves, lies in the sulcus between the biceps and the long head of the triceps.

The radial nerve is identified behind the brachial artery. By separation of the fascia investing the long head of the triceps, it is possible to trace the nerve downward and laterally between this head and the medial head of the triceps. The long and lateral heads of the triceps can be separated posteriorly in the lower end of the wound without cutting any muscle fibers. When this has been done, the radial nerve will be found close to the humerus in the musculospiral groove. The profunda artery accompanies the nerve (fig. 143), and motor branches emerge to the lateral and medial heads of the triceps and the anconeus. A sensory branch, the dorsal antebrachial cutaneous nerve, also emerges at this point. All of these structures must be respected.

Closure requires approximation of the deep fascia, the subcutaneous tissues, and the skin.

Exposure in the arm.—The patient lies with the arm resting easily against the body and the forearm flexed across the abdomen at an angle of 45° with the arm (fig. 144).

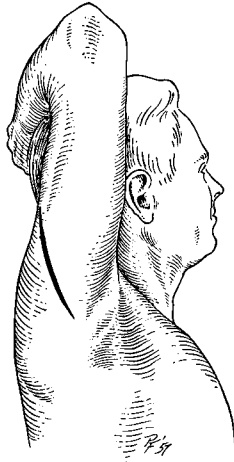

FIGURE 142.—Skin incision for exposure of radial nerve in upper third of arm.

FIGURE 143.—Surgical exposure of radial nerve in upper third of arm.

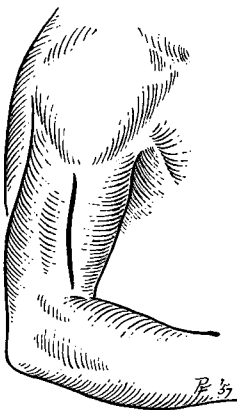
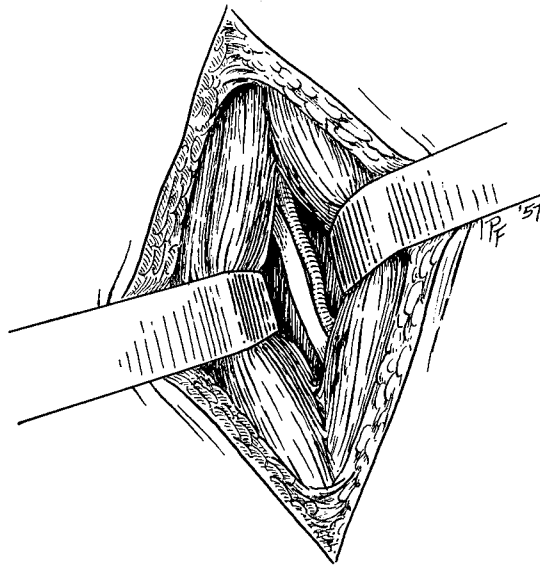

FIGURE 144.—Skin incision for exposure of radial nerve in lateral aspect of arm.

The incision is begun in the midlateral portion of the arm, over the lateral bicipital sulcus, 1 inch below the insertion of the deltoid. It is carried downward and slightly forward toward the prominence of the brachioradialis and extensor carpi radialis at the elbow. If the incision must be carried below the elbow, it crosses the antecubital fossa transversely, in order to prevent contracture or keloid at the bend of the elbow, and then curves gently back to a straight course over the radius.

The deep fascia is incised, and a plane of cleavage is sought between the brachialis and the lateral head of the triceps. The radial nerve lies deep between these muscles. As the nerve courses upward, it pierces the lateral intermuscular septum; this dense fascial investment must therefore be divided to expose the upward passage of the nerve. In its downward extension, the radial nerve lies deep between the brachialis and brachioradialis, dividing at the elbow into the superficial and deep radial nerves. It is accompanied by an anterior terminal branch of the profunda artery, and it gives off branches to the brachioradialis, the extensor carpi radialis longus, the lateral portion of the brachialis, and the elbow joint. Precautions must be taken to identify and avoid these structures. If separate nerve branches should be cut, they must be repaired.

The frequency with which the radial nerve and humerus are both injured is due to their close proximity in this region, in which the nerve is also particularly liable to compression or destruction by the formation of callus. Moreover, the numerous and variable muscle branches, the proximity of many muscles affecting refined movement, and the frequency with which injuries to the middle and lower arm involve the elbow greatly increase the difficulties attendant on exploration of the radial nerve in this region.

Closure requires approximation of the deep fascia, the subcutaneous tissues, and the skin. It is not necessary to reapproximate muscle sheaths.

Exposure in the forearm.—The patient lies supine, with the affected extremity resting in midposition on an arm board. The line of incision corresponds to a line drawn between the external condyle of the humerus and the tubercle of the radius. If exposure at the elbow is desired, a transverse incision is used, to protect the flexion crease. Any extended exposure in the forearm should be made through a curved or oscillating incision to prevent contracture or keloid (fig. 145). Branches of the dorsal and lateral antebrachial cutaneous nerves course subcutaneously in this region. The deep fascia is divided.

The deep radial nerve is approached at the elbow by separating the loose areolar tissue between the biceps tendon and the brachioradialis muscle. The extensor carpi radialis longus, which lies beneath the brachioradialis, is retracted laterally. The nerve, which runs between it and the brachialis, is thus exposed. Near the capitellum of the humerus, the nerve divides into deep and superficial branches. The deep radial branch passes around the head of the radius to enter the substance of the supinator, while

the superficial radial branch continues superficially, under cover of the brachioradialis.

In order to expose the deep radial nerve in the upper forearm as it traverses the substance of the supinator, it is necessary to make multiple splits in the muscle or, in some cases, to sever part of it (fig. 146). The utmost care is necessary in dissection to avoid injury of the emerging branches of the deep radial nerve, which include those to the brachioradialis, extensor carpi radialis brevis, supinator, extensor digitorum communis, extensor digiti quinti proprius, and extensor carpi ulnaris. It should be emphasized that injury to the deep radial nerve is often impossible to repair unless it was made with a sharp instrument or was associated with a fracture of the upper end of the radius. This is because of the close proximity of the nerve to the muscles it innervates, its numerous branches, and the shortness of these branches. The superficial radial nerve, which lies under cover of the brachioradialis muscle in the upper forearm, is seldom explored independently for the purpose of deliberate suture unless it is the site of a painful neuroma.

In the middle third of the forearm, the deep radial nerve can be found by separating the extensor carpi radialis brevis and the extensor digitorum communis. It accompanies the posterior interosseous artery across the dorsal surface of the abductor pollicis longus. This nerve is small, and its motor branches, which emerge in this area to supply the extensor indicis proprius and the extensor muscles of the thumb, are smaller. When scarring is present, therefore, identification and suture are both difficult. The deep radial nerve terminates in the dorsal interosseous nerve, which passes through the groove for the common extensors to the wrist. Here it supplies trophic and sensory innervation to the carpal articulations.

Wound closure in the forearm includes approximation of the deep fascia, subcutaneous tissues, and skin.

Methods of Gaining Length

The radial nerve is under greatest tension when the arm is fully pronated, extended, and abducted at the shoulder. Conversely, maximal relaxation is achieved when the arm is fully adducted, externally rotated at the shoulder, and flexed across the chest, with the forearm flexed on the arm and supinated. As a rule, nerve suture can be effected with this positioning. If, however, repair cannot be accomplished even with optimum positioning, the best plan is to transfer the nerve to an anterior position in the arm and make it pass between the biceps and the brachialis, to rejoin the divided nerve segments at the inner aspect of the arm, as recommended by Bunnell. Since the branches of the nerve to the triceps anchor the nerve trunk, they must be gently stripped upward until sufficient mobilization is achieved.

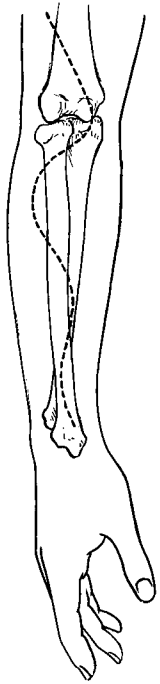

FIGURE 145.—Skin incision for exposure of radial nerve in forearm.

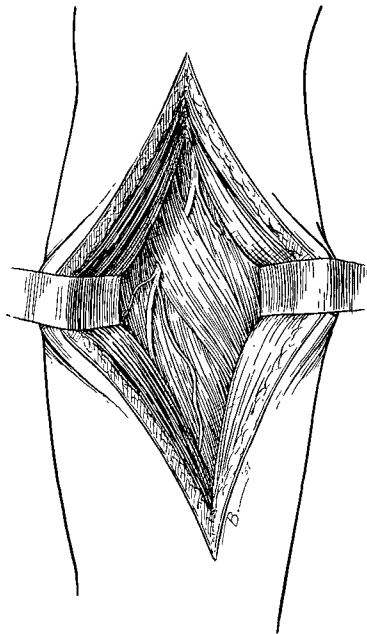

FIGURE 146.—Surgical exposure of deep radial nerve.

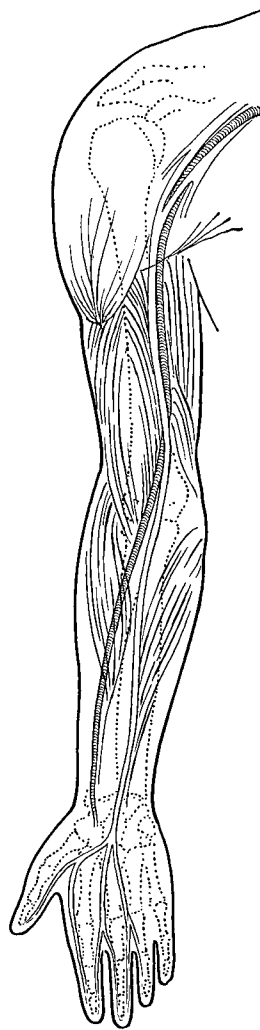

FIGURE 147.—Distribution of median nerve in arm. Skin incision for its exposure is shown by dotted lines.

THE MEDIAN NERVE

General Anatomy

The median nerve originates in the medial aspect of the arm, deep in the axilla, lateral to the axillary artery and near the lower border of the pectoralis minor muscle (fig. 147). It is formed by fusion of components of the lateral and medial cords of the brachial plexus. Its nerve fibers are derived principally from the sixth, seventh, and eighth cervical nerves and the first thoracic nerve (p. 310). It courses vertically through the medial aspect of the arm, within the neurovascular bundle. It lies lateral to the brachial artery in the upper arm but crosses it anteriorly in the middle of the arm and lies medial to it from that point to the elbow.

The median nerve is found anterior to the medial intermuscular septum. It gives out no branches in the arm but occasionally receives a small branch from the musculocutaneous nerve.

At the elbow, the median nerve assumes an anterior course which carries it beneath the lacertus fibrosus and between the two heads of the pronator teres muscle. In the upper forearm, it lies deeply bedded, between the flexor digitorum sublimis and flexor digitorum profundus muscles, but, as it approaches the wrist, it comes to lie superficially, between the flexor carpi radialis and flexor digitorum sublimis tendons and beneath the tendon of the palmaris longus. From the elbow downward, branches are supplied successively to the elbow joint, pronator teres, flexor carpi radialis, palmaris longus, flexor digitorum sublimis and profundus, flexor pollicis longus, and, through the volar interosseous nerve, to the pronator quadratus.

At the wrist, except for the superficial palmar branch, the median nerve passes between the anterior annular (transverse carpal) ligament superficial to the flexor tendons. At the lower border of this ligament, it divides into three common volar digital nerves that lie dorsal to the superficial volar arch (fig. 148). These nerves, in turn, divide into the proper volar digital nerves that lie on the volar side of the digital arteries and send motor and sensory branches to the thenar eminence, the thumb, the index and middle fingers, and the radial side of the ring finger. The motor branches innervate, respectively, the abductor and flexor pollicis brevis, the opponens pollicis, and the first and second lumbrical muscles. Sensation to the medial border of the eminence is supplied by the palmar branch of the median nerve.

Surface Anatomy

A line drawn from beneath the lower border of the pectoralis major at the apex of the axilla along the medial aspect of the biceps brachii downward to the lacertus fibrosus conforms to the course of the median nerve in the arm (fig. 149). From this latter point to the midvolar aspect of the wrist, the median nerve descends in the forearm. The thenar crease marks

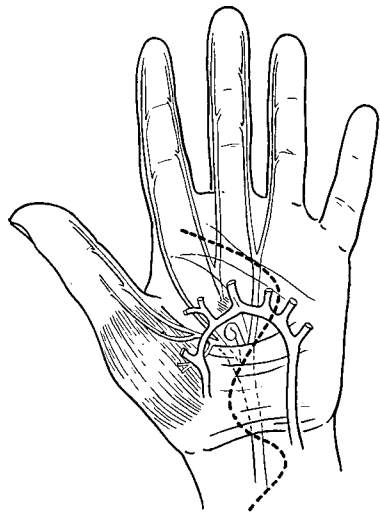

FIGURE 148.—Terminal branches of median nerve below annular ligament. Dotted lines indicate skin incision for surgical exposure.

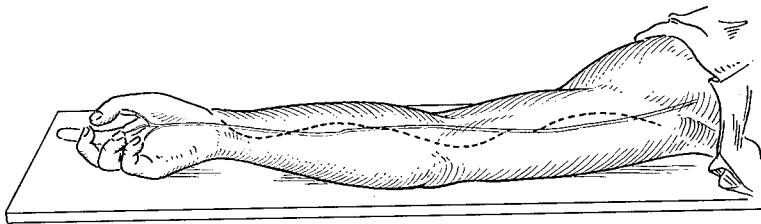

FIGURE 149.—Course of median nerve in upper extremity.

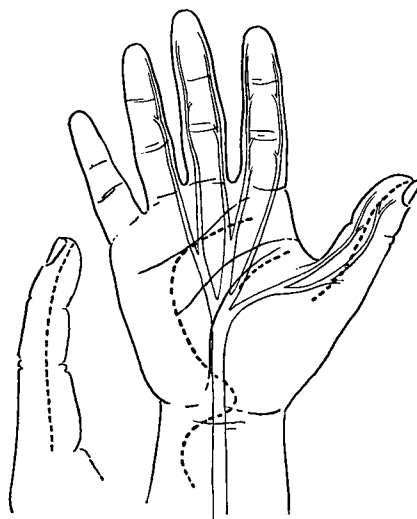

FIGURE 150.—Skin incisions for exposure of terminal branches of median nerve.

its course in the hand, although the nerve begins to divide near the proximal transverse palmar crease (fig. 150). The digital nerves lie in a midlateral position along each side of the fingers.

Surgical Approach

Positioning and preparation.—The patient lies supine, with an ether frame so placed that drapes can extend to the shoulder girdle. This is to make the entire arm accessible in the operative field. Experience has proved this precaution a necessity except in exploration in the lower forearm and hand. The drapes must cover the whole body, and movement of shoulder, elbow, and wrist joints must be possible in a sterile field. The hand is encased in a sterile glove and the arm in sterile stockinet, in which windows may be cut as necessary to correspond with the proposed skin incisions; if they are required, the edges of the stockinet incised should be folded under, to prevent entrance of lint into the wound.

The extremity prepared in this manner permits any necessary incision, free range of motion, and freedom for examination on electrical stimulation of the nerve.

Exposure in the arm.—The arm, resting on an arm board, is abducted and externally rotated. The incision, which follows the medial bicipital groove, is curved to prevent keloid or contracture. The medial brachial and antebrachial nerves are encountered in the subcutaneous tissue, the latter from the lower third of the arm downward. The basilic vein likewise pierces the deep fascia in the lower third of the arm, to pass from a superficial to a deep position. The neurovascular bundle is identified by palpating the brachial artery under the medial intermuscular septum between the bellies of the biceps and triceps muscles. It is opened longitudinally under tension.

The median nerve lies anterior to the medial intermuscular septum, lateral to the brachial artery in the upper arm. It crosses the artery anteriorly in the middle third of the arm and lies medial to it in the lower third. From the middle third of the arm downward, the ulnar collateral artery and vein occupy a position lateral to the median nerve. Throughout the arm, anastomosing branches of the venae comitantes enmesh the deeper structures. The ulnar nerve, because it is smaller and situated more medially and posteriorly, is unlikely to be confused with the median nerve. If, however, tissue distortion is great, electrical stimulation may be necessary to identify the two nerves accurately.

Closure entails approximation of the deep fascia and suture of the subcutaneous tissues and skin (fig. 151).

Exposure at the elbow.—The arm rests in supination. The incision crosses the elbow transversely, in line with the flexion creases. The cubital and basilic veins are spared. The medial antebrachial cutaneous nerve lies near the medial reach of the incision and the lateral antebrachial cutaneous nerve near the lateral. The deep fascia is divided; the lacertus fibrosus,

which crosses the antecubital fossa obliquely, is used as a landmark (fig. 152).

The median nerve courses immediately beneath the midportion of the lacertus fibrosus. Above it, the median nerve lies medial to the brachial artery and biceps tendon and rests on the brachialis muscle along with the inferior ulnar collateral artery. Below this fibrous band, the nerve is medial to the ulnar artery and in lateral relation with the pronator teres, beneath whose two heads it disappears. Articular branches to the elbow and branches to the pronator teres arise from the median nerve as it passes through the antecubital fossa. The nerve in this location lies relatively uncovered and can be exposed merely by separating loose areolar tissue and fat.

Closure requires approximation of the deep fascia, subcutaneous tissues, and skin.

Exposure in the forearm.—The patient lies with the forearm and hand supinated. A curved incision is centered over the midvolar aspect of the forearm. The medially and laterally placed antebrachial cutaneous curves are avoided. The deep fascia is cut longitudinally.

To expose the median nerve in the upper forearm, the flexor carpi radialis is retracted medially and the brachioradialis laterally. The humeral head of the pronator teres is detached. The nerve is thus exposed as it crosses the smaller ulnar head of the pronator teres. At this level, the median nerve crosses the ulnar artery anteriorly and descends into the mid forearm in company with the median artery. Branches to the flexor carpi radialis, palmaris longus, and flexor digitorum sublimis are given off at this level. The volar interosseous nerve arises at the lower border of the pronator teres, on a level with the bicipital tubercle of the radius. This nerve supplies the pronator teres and, in its course to the wrist along the interosseous membrane, also supplies the two lateral divisions of the flexor digitorum profundus and the flexor pollicis longus (fig. 153).

To expose the median nerve in the mid forearm, it is necessary to divide the radial attachment of the flexor digitorum because the nerve lies between this muscle and the flexor digitorum profundus. In some cases, however, adequate exposure of a localized lesion can be secured merely by separating the obliquely coursing fibers of this muscle. Since most of the branches of the median nerve in the forearm arise in the upper third, they will not be encountered in the mid forearm unless there is a variation in the mode of origin.

The median nerve is quite easily exposed in the lower forearm. Here it is centrally situated beneath the deep fascia and can be visualized by retracting the flexor carpi radialis on the radial side and the palmaris longus and flexor digitorum sublimis tendons on the ulnar side. The only branch of the median nerve which arises in the lower forearm is the palmar branch (palmar cutaneous nerve), which emerges just above the transverse carpal ligament.

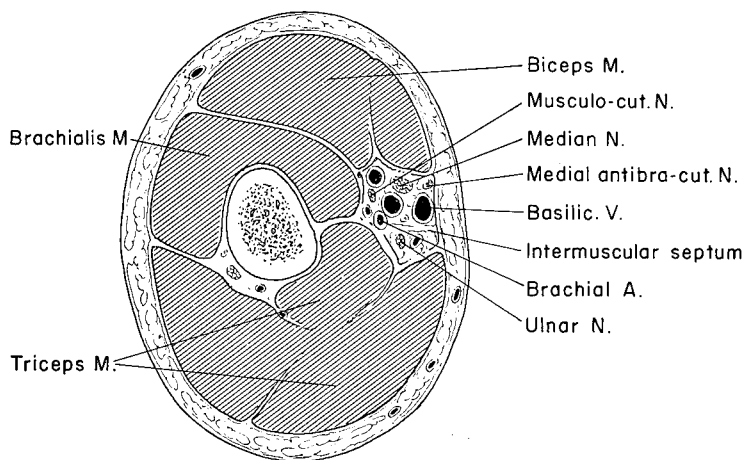

FIGURE 151.—Cross section of middle third of arm showing relation of median nerve to neurovascular bundle.

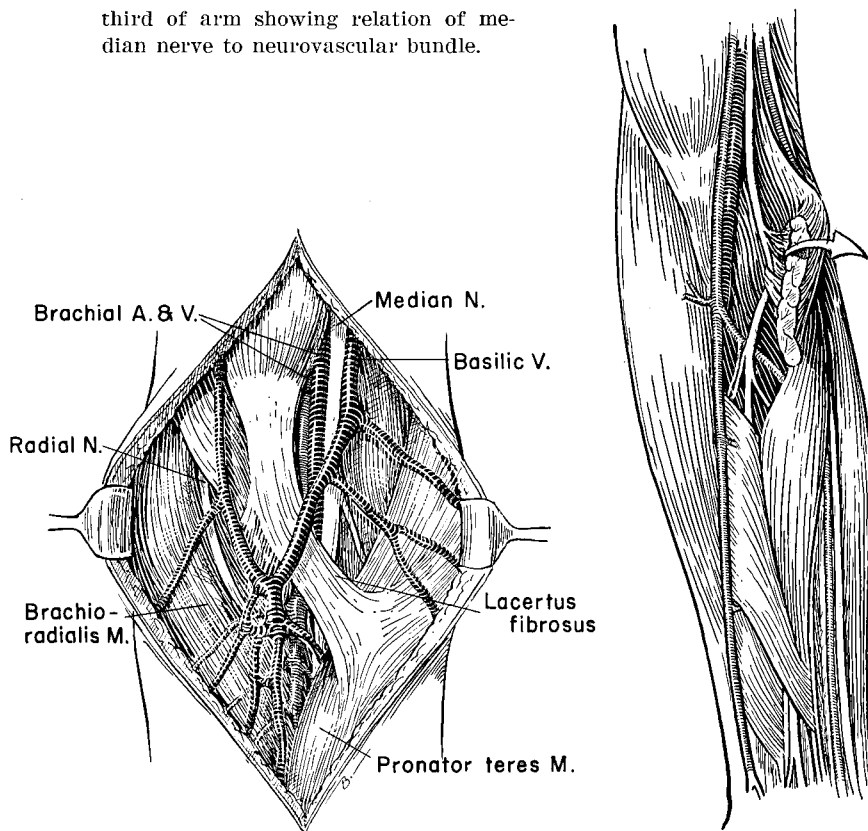

FIGURE 152.—Surgical anatomy of antecubital fossa.

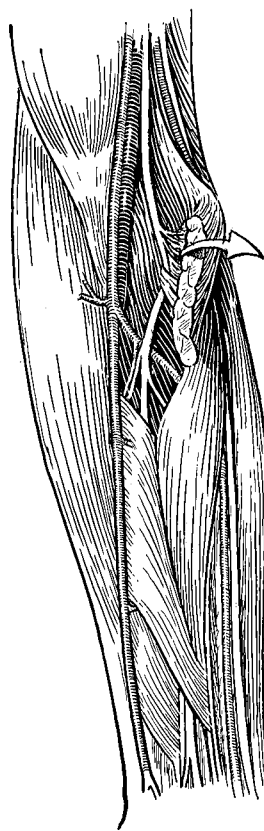

FIGURE 153.—Motor branches of median nerve in forearm.

Closure requires reapproximation of any muscles or tendons of origin which have been cut. The deep fascia, subcutaneous tissues, and skin are sutured in layers.

Exposure at the wrist.—The wrist is held with the hand supinated. A transverse incision is made across the flexion creases of the wrist, with provision for extension if necessary (fig. 154).

When the deep fascia has been incised, the palmar cutaneous branch is seen lying superficial to the transverse carpal ligament. This branch carries sensation to the central depressed surface of the palm and to the medial border of the thenar eminence. The median nerve lies beneath the transverse carpal ligament, in front of the flexor tendons, in the middle of the wrist, under the tendon of the palmaris longus. The palmaris longus is retracted toward the ulna, and a linear incision is made between the tendons of the flexor digitorum sublimis and the flexor carpi radialis. The median nerve lies between these tendons, superficial to the tendons of the flexor pollicis longus and the flexor digitorum profundus (figs. 154 and 155). It is unlikely to be confused with the ulnar nerve, which lies far off toward the ulna, beneath the tendon of the flexor carpi ulnaris and the ulnar artery.

Closure requires suture of the deep fascia, subcutaneous tissues, and skin.

Exposure in the hand.—The incision in the hand conforms to the natural creases (fig. 150).

The median nerve, at the point at which it divides into the common volar digital nerves, lies in the middle of the palm, beneath the midportion of the thenar or radial crease, in front of the flexor tendons, and behind the superficial volar arch (fig. 148). The common volar digital nerves, in turn, promptly divide into the proper volar digital nerves that extend to their respective fingers and into a smaller branch to the thenar eminence. This branch supplies the abductor pollicis, the opponens, and the superficial head of the flexor pollicis brevis. Branches to the first and second lumbricales arise respectively from the first and second common volar digital nerves. A branch which arises from the common volar digital nerve communicates with the ulnar nerve and may contribute a twig to the third lumbrical muscle.

The proper volar digital nerves, which supply sensation to the pulp and matrices of the nails of the thumb, index, and middle fingers, as well as to the radial side of the fourth finger, lie along the respective sides of these digits and may be explored as far as the distal digital creases. The incision is made in a linear direction on the midlateral aspect of the finger (figs. 150 and 156). It is frequently necessary, to secure adequate exposure, to divide the accompanying digital artery and vein. The lateral reflections of the pulleys are to be avoided.

Buried sutures are seldom required to close an incision in the hand or fingers. If they are necessary, they should be used sparingly. Closely spaced interrupted sutures that approximate the entire thickness of the skin eliminate the risk of painful subcutaneous foreign body reactions.

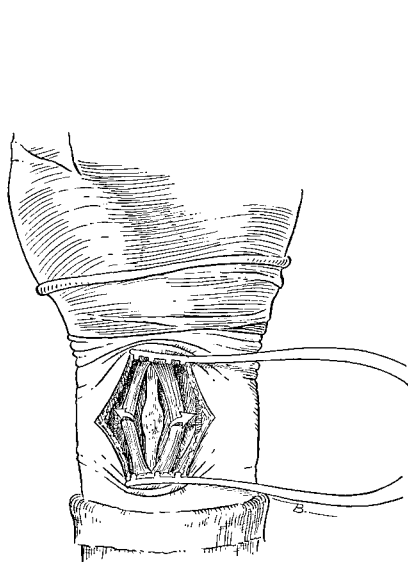

FIGURE 154.—Surgical exposure of median nerve at wrist.

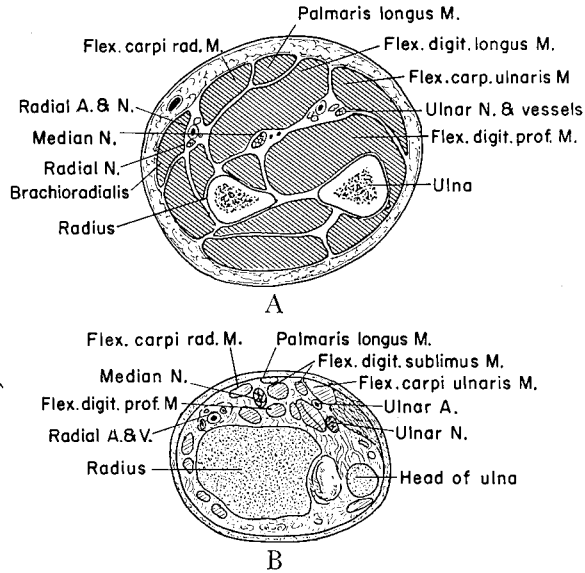

FIGURE 155.—Cross section showing anatomy of median nerve in forearm. A. In mid forearm. B. Above annular ligament.

FIGURE 156.—Surgical exposure of digital nerve in index finger.

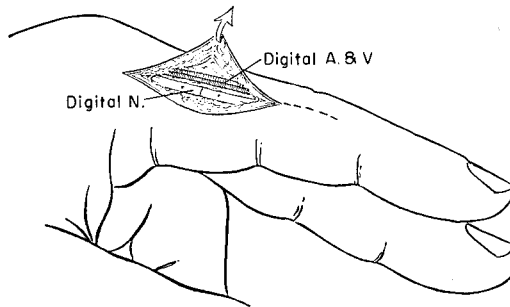
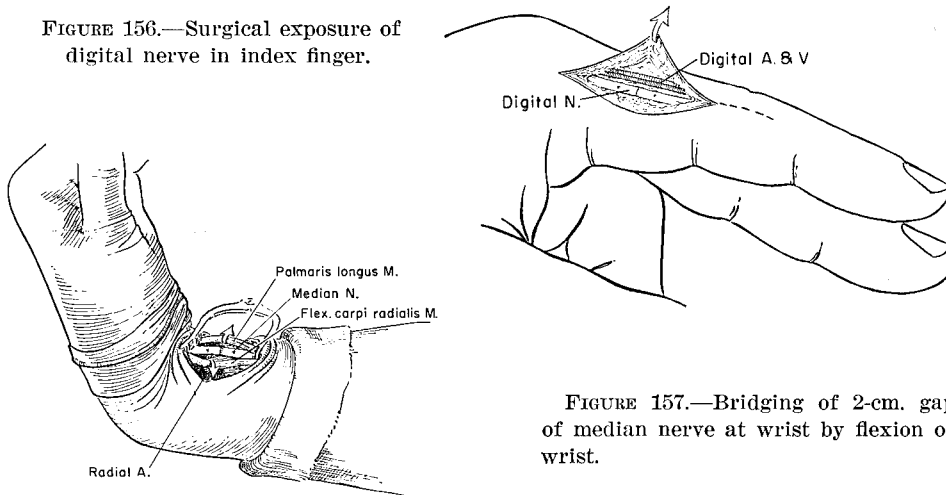

FIGURE 157.—Bridging of 2-cm. gap of median nerve at wrist by flexion of wrist.

Methods of Gaining Length

The median nerve is under greatest tension when the arm is abducted and externally rotated, the forearm is extended and pronated, and the wrist and fingers are extended. Relaxation is maximal with the arm adducted and internally rotated and the elbow, wrist, and fingers flexed; the hand is in neutral position. Defects up to almost an inch in the hand can be overcome by flexing the fingers. Defects of $1\frac{1}{2}$ to 2 inches at the wrist can be bridged by sharply flexing the wrist and fingers (fig. 157). Defects of $2\frac{1}{2}$ to 3 inches in the arm and forearm can be overcome by stripping the nerve branches in the forearm and flexing the elbow and wrist (figs. 158 and 159). Even larger defects can be bridged by detaching the humeral head of the pronator teres and rerouting the nerve to a subcutaneous position at the elbow, in combination with freeing the nerve high in the arm and flexing the elbow and wrist.

THE ULNAR NERVE

General Anatomy

The ulnar nerve arises from the medial (inner) cord of the brachial plexus, which itself originates in the anterior divisions of the eighth cervical and first thoracic spinal roots. The nerve passes distally with, and mesial to, the brachial artery and median nerve into the lower third of the arm. Here it deviates posteriorly, piercing the medial intermuscular septum to cross the medial head of the triceps muscle. After it crosses the biceps, the ulnar nerve enters the ulnar groove posterior to the medial epicondyle of the humerus. It is easily palpable in its superficial position as it lies beneath the dense fascia between the olecranon and the medial epicondyle. The branches to each head of the flexor carpi ulnaris muscle arise just distally, followed by two branches to the flexor digitorum profundus of the ring and the little finger (fig. 160).

The ulnar nerve enters the forearm beneath an aponeurotic arch formed by the junction of the two heads of the flexor carpi ulnaris muscle. As the nerve traverses the medial aspect of the forearm, it is covered in the upper third by the flexor carpi ulnaris muscle. For the remainder of its course in the forearm, it lies in close approximation to the ulnar artery and vein, within the sheath of the common flexors of the fingers.

About 5 cm. above the wrist, the ulnar nerve divides into the dorsal cutaneous and the volar branch. The dorsal cutaneous branch pierces the deep fascia beneath the flexor carpi ulnaris and goes to the dorsum of the hand. The volar branch enters the hand through an opening in the transverse carpal ligament on the radial side of the pisiform bone. Separation into superficial and deep branches occurs at the lower margin of the ligament.

The superficial branch is sensory to the volar aspect of the hand, the ulnar aspect of the ring finger, and the little finger. It sends small motor

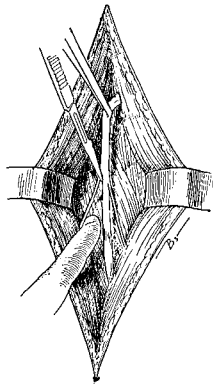

FIGURE 158.—Stripping of muscular branches of median nerve in upper forearm to attain additional length.

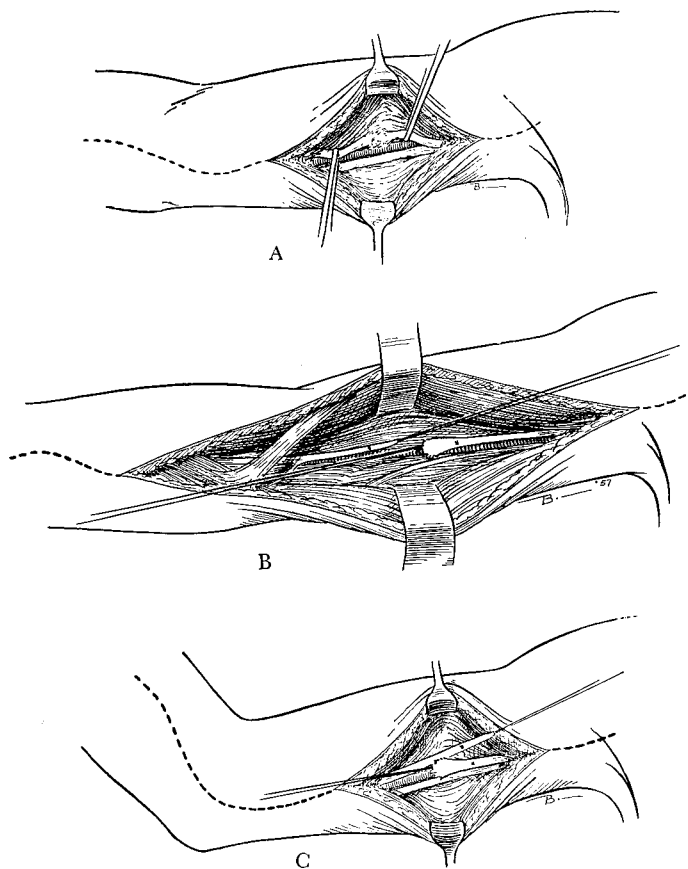

FIGURE 159.—Technique of repair of injured median nerve in arm. A. Exposure of nerve. B. Proximal neuroma and distal glioma freed and held with fine traction sutures. Note gap between nerve ends with forearm extended. C. Overlapping of nerve ends achieved by flexing forearm and abducting arm.

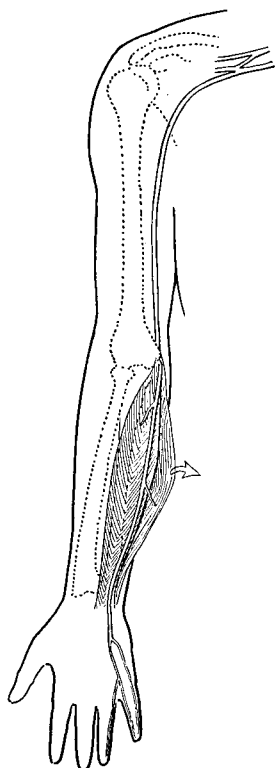

FIGURE 160.—Distribution of ulnar nerve in upper extremity.

branches to the palmaris brevis muscle. The deep branch, which is principally motor, penetrates the depths of the palm, in company with the deep volar arch of the artery. It then passes between the abductor digiti quinti and the flexor digiti quinti brevis, to lie beneath the flexor tendons of the fingers. It supplies the three short muscles of the small finger, the interossei, and the third and fourth lumbricales, as well as the adductor pollicis and the medial head of the flexor pollicis brevis. Small articular branches of the superficial branch of the ulnar nerve pass to the wrist joint along its course.

Surface Anatomy

The ulnar nerve can be rolled beneath the fingers as it lies in relation to the brachial artery and the median nerve along the medial aspect of the arm. At the elbow, it is readily identified in the ulnar groove. At the wrist, it is immediately subjacent to the flexor carpi ulnaris tendon, just proximal to the insertion of this tendon into the pisiform bone. In the upper third of the forearm, the medial antebrachial cutaneous nerve crosses the ulnar nerve obliquely, in a dorsomedial direction, on the external surface of the fascia of the flexor carpi ulnaris muscle.

Surgical Approach

Positioning and preparation.—The patient lies supine, with the shoulder at the edge of the table and the arm abducted on an arm board placed high under the shoulder. After preliminary antiseptic preparation of the skin from the axilla down to, and including, the tips of the fingers, the hand is encased in a sterile glove. Drapes are then so placed as to allow exposure as far as the axilla. The probable lines of incision are delineated on the skin by scratch marks made throughout the course of the nerve, after which the arm is encased in sterile stockinet for skin coverage. Pads placed beneath the arm facilitate exposure of the nerve.

Exposure in the axilla.—A transverse incision, already described (p. 316), is employed for exposure of the ulnar nerve in the axilla. This incision follows the skin lines but does not cross them. Incapacitating contracting keloids form when incisions cross the skin lines in the axilla. A separate incision can be started several centimeters below the axilla for mobilization of the nerve (fig. 161). The subcutaneous tissues of the axilla and the axillary fascia are divided to expose the neurovascular bundle.

With the arm abducted, the ulnar nerve lies dorsomedial to the axillary artery, while the median nerve lies anterolateral to the artery and the radial nerve lies dorsolateral. The medial antebrachial cutaneous nerve lies between the median and ulnar nerves, on the medial aspect of the axillary vessels. The ulnar nerve is easily exposed in this region, in which, however, it is seldom injured independently. Injury to it is usually associated with injury to the median and radial nerves and to the axillary artery.

Exposure in the arm.—The patient lies supine, with the arm abducted on an arm board and the forearm fully supinated. In the upper two-thirds of the arm, the incision is the same as that used for the median nerve (p. 330); that is, it roughly follows the course of the neurovascular bundle in a gently oscillating curve. In the lower third of the arm, the incision deviates posteriorly toward the medial epicondyle. It crosses the elbow anterior to the epicondyle, however, to avoid an incision over the posteromesial aspect of the elbow, which is an area subject to considerable trauma.

The deep fascia is divided, care being taken not to injure the medial brachial cutaneous nerves. By retraction of the border of the coracobrachialis in the upper part of the arm and of the biceps lower down, the neurovascular bundle is exposed. If it is necessary to obtain exposure in the lower axilla, the inferior fibers of the pectoralis major muscle may be cut. When the neurovascular bundle is opened, the ulnar nerve is exposed in its posterior portion. In the lower third of the arm, the nerve pierces the medial intermuscular septum and lies in close relation to the posterior surface of the septum as far distally as the medial epicondyle.

Exposure of the ulnar nerve in the neurovascular bundle is a tedious procedure. Dissection must be cautious, to avoid injury to the brachial

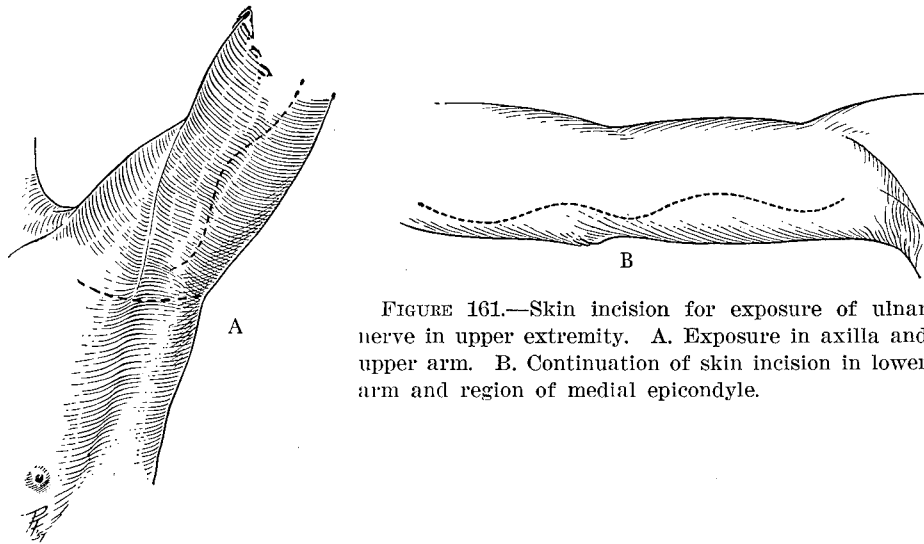

FIGURE 161.—Skin incision for exposure of ulnar nerve in upper extremity. A. Exposure in axilla and upper arm. B. Continuation of skin incision in lower arm and region of medial epicondyle.

artery and veins. If there is much scarring, the procedure is particularly time consuming.

Identification sutures, with due attention to the surface markings of the ulnar nerve, are placed at the center of the mesial half of the nerve, both above and below the lesion, to facilitate proper alinement of the nerve for suture. These sutures are placed before the nerve is freed from its bed. The nerve is mobilized as far as is necessary distally and proximally to obtain length for overcoming the gap in it. Dissection is carried out with as much sparing as possible of the vascular supply.

Frequently, in order to gain sufficient length for repair of the ulnar nerve in the axillary area, it is necessary to transplant it anterior to the medial epicondyle. When the nerve is in its normal position behind this epicondyle, maximum relaxation is obtained by flexion of the wrist, extension of the elbow, and adduction of the arm. After transplantation of the ulnar nerve, however, to a position anterior to the medial epicondyle, the greatest relaxation is gained by flexion of the wrist, flexion of the elbow, and adduction of the arm.

Exposure at the elbow.—In general, since almost any surgery on the ulnar nerve in the elbow region requires its transplantation to the anterior position, considerable exposure of the nerve is necessary in both the arm and forearm. The arm is abducted and externally rotated. The elbow is somewhat flexed, and the hand is supinated.

The incision begins in the region of the point of penetration of the intermuscular septum by the ulnar nerve. It extends distally along the septum to a point about $1\frac{1}{2}$ inches above the medial epicondyle. Here it sweeps forward in a gentle curve anterior to the medial epicondyle. Then, after

crossing the antecubital space, the incision continues across the junction of the two heads of the flexor carpi ulnaris about $1\frac{3}{4}$ inches below the epicondyle. From this point, the incision may be extended distally in a gently oscillating curve to the wrist on the radial side of the pisiform bone.

The fascia is divided in the line of the uppermost part of the incision, and the nerve is isolated. At the elbow, the posterior skin flap is dissected free at the level of the fascia and displaced posteriorly, thus exposing the region of the ulnar groove. The heavy fascia over the nerve is then divided. Anastomotic vessels about the elbow joint may give considerable trouble, but careful ligation will control bleeding.

As the nerve is exposed, the first (articular) branch of the ulnar nerve comes into view on the inner aspect. The branches to the two heads of the flexor carpi ulnaris muscle are distal to the articular branch. It may be necessary, in order to expose the ulnar nerve after it passes between the two heads of the flexor carpi ulnaris muscle, to split the muscle at the point of junction of the heads.

In this region, the medial antebrachial cutaneous nerve crosses the forearm from a ventral position to a dorsomedial position. When it must be divided, to facilitate exposure of the ulnar nerve, the ends should be marked and the nerve resutured when skin closure is done; failure to resuture it leads to anesthesia of the medial aspect of the forearm. The branches of the ulnar nerve which supply the flexor digitorum profundus of the ring and little fingers should be preserved, whenever possible, during transplantation of the nerve. They arise from the nerve trunk, just below the olecranon and distal to the point of origin of the flexor carpi ulnaris branches.

Exposure in the forearm.—The ulnar nerve in the forearm lies along an essentially straight line between the radial side of the pisiform bone and the medial epicondyle. In the lower forearm, it lies to the radial side of the flexor carpi ulnaris tendon, on the flexor digitorum profundus muscle. It is contained within the thin enveloping fascial sheath of the flexor digitorum muscles. The nerve is accompanied in its course by the ulnar vessels.

Exposure of the nerve is most easily begun at the wrist, the dissection then being carried proximally into the forearm. When identification is difficult at the wrist, the nerve may be exposed at the medial epicondyle and traced distally between the two heads of the flexor carpi ulnaris muscle (fig. 162).

The dorsal cutaneous branch arises from the main trunk of the ulnar nerve near the junction of the middle and lower thirds of the forearm. This branch should be carefully protected, for it supplies sensation to the dorsum of the hand and fingers on the ulnar aspect of the hand; this portion of the hand is particularly exposed to trauma, and serious trophic changes can follow the division of the nerve.

Exposure at the wrist.—The arm is fully abducted on an arm board, with the elbow extended and the hand fully supinated. The ulnar nerve can

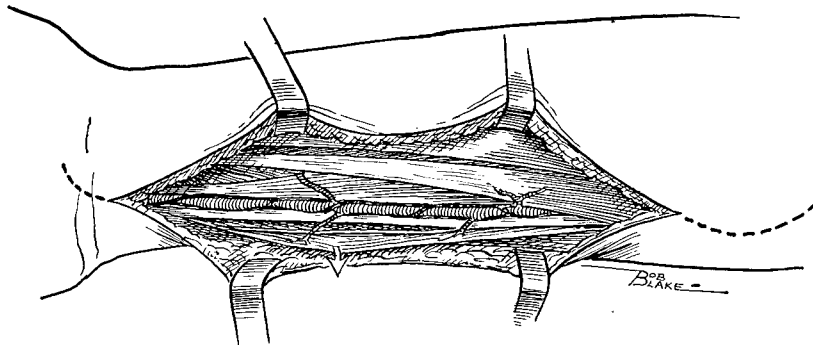

FIGURE 162.—Surgical exposure of ulnar nerve in lower forearm.

often be palpated just proximal to the flexion creases of the wrist; at this point, it lies dorsolateral to the tendon of the flexor carpi ulnaris muscle.

The incision should follow the skin lines for some distance but should not cross the flexion creases in a straight line (fig. 163). The nerve is first exposed proximal to the lesion by dividing the fascia between the flexor carpi ulnaris tendon and the flexor sublimis tendons. In the lower

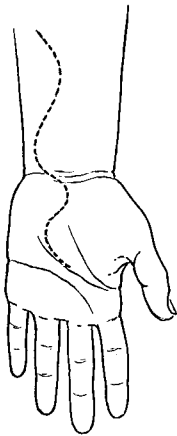

FIGURE 163.—Skin incision for exposure of ulnar nerve at wrist and in hand.

third of the forearm, the nerve lies within the fascial sheath of the common flexor tendons of the fingers; this sheath must be divided to expose it. In this area, the nerve lies close to the ulnar artery and vein, and careful dissection is required to avoid injury to the vessels. The dorsal sensory branch of the ulnar nerve leaves the main trunk from 2 to 4 inches above the wrist and pierces the deep fascia to pass around the ulna to the dorsum of the wrist.

Distally, the ulnar nerve is exposed as it lies beneath the annular ligament to the radial side of the pisiform bone. The ligament may be divided longitudinally over the nerve without causing any disturbance in the function of the wrist. The nerve divides into superficial and deep volar branches at the distal border of the ligament. Here, the deep branch passes into the depth of the palm, in company with the deep volar vascular arch, while the superficial branch runs directly to the ring and little fingers, sending small motor branches to the palmaris brevis muscle.

Before the proximal and distal segments of the ulnar nerve are freed at the wrist, identification sutures are placed in the sheath, to provide for accurate approximation of the cut ends. The nerve is usually freed without difficulty from the adjacent tendons, but some trouble may be encountered in the region of the scar because of overgrowth of the cut ends of the tendons and nerves. Great care must be taken to identify the proximal and distal nerve ends, which are often difficult to distinguish from each other in scar tissue. One valuable differential feature is the presence of blood vessels within the nerve sheath and their absence in the tendons. Even when the transected ends of tendons and nerves are remarkably similar, proximal and distal dissection will serve to identify the nerve by its position, its anatomic proximity to the artery and vein, and its nutrient vessels.

Repair of tendons should be carried out simultaneously with repair of the nerve when there are severe injuries at the wrist or in the lower forearm. Defects of $1\frac{3}{4}$ to $3\frac{1}{2}$ inches at the wrist can be overcome by flexion of the wrist and proximal dissection of the nerve. At times, however, it may be necessary to transplant the nerve at the elbow in order to gain sufficient relaxation for satisfactory nerve suture.

Technique of Transplantation at the Elbow

Transplantation of the ulnar nerve is sometimes indicated for progressive neuritis resulting from trauma to the nerve in its normal position behind the medial epicondyle, as well as to gain sufficient length for satisfactory anastomosis of a severed nerve.

The incision is begun over the medial intermuscular septum in the lower third of the arm. It passes anterior to the medial epicondyle of the humerus in a sweeping curve to the midportion of the belly of the flexor carpi ulnaris muscle, about $1\frac{1}{2}$ inches below the medial epicondyle. The skin and subcutaneous tissues anterior to the medial epicondyle are dissected radially at the level of the deep fascia, to expose the ulnar side of the biceps tendon. This usually cannot be accomplished without division of the medial antebrachial cutaneous nerve in the upper third of the forearm. This nerve should be marked for suture at the time the skin is closed.

The ulnar nerve is then dissected proximally as far as the point at which it pierces the intermuscular septum. The septum is divided and the

nerve is placed anterior to the septum, to promote passage from the neurovascular bundle into the forearm in a straight line.

The nerve is next dissected away from the enveloping areolar tissue with careful sharp dissection. Its articular branch is identified after the dense fascia between the medial epicondyle and the olecranon has been divided, and the branch is itself divided. The branches to the two heads of the flexor carpi ulnaris, which leave the main trunk just distal to the articular branch, are identified and mobilized proximally along the ulnar nerve into the lower third of the arm. This is accomplished by carefully cutting the nerve sheath at the junction of the branch and the main nerve trunk and, by cautious dissection, separating the nerve bundle from the main nerve to achieve maximum mobility. If necessary, dissection (fig. 164) may be continued proximally for 3 or 4 inches.

Branches of the ulnar nerve to the flexor profundus muscles of the ring and little fingers are identified as they leave the main trunk slightly distal to the flexor carpi ulnaris branches. These branches, like the others, are freed from the trunk to allow for anterior displacement of the main nerve.

After satisfactory relaxation of tension has been obtained by dissection of the branches, the ulnar nerve is placed on the deep fascia of the flexor muscle group, which arises from the medial epicondyle in such a position that the nerve follows a straight line down the forearm (fig. 164B). It is a wise precaution, to prevent posterior displacement of the nerve on motion of the elbow, to suture the overlying subcutaneous tissue to the fascia posterior to the transplanted nerve trunk. In this position, the nerve is covered by a pad of fat and subcutaneous tissue.

Some surgeons prefer to pass the ulnar nerve deep to the muscles arising from the medial epicondyle. If the nerve is divided in the upper third of the forearm, it may be passed through a tunnel made between the flexor digitorum profundus muscle and the overlying flexor sublimis and pronator teres muscles. On the other hand, if the nerve is intact, the flexor sublimis and pronator teres muscles, which arise from the medial epicondyle, may be divided close to their origin and resutured after the nerve trunk has been placed on the ventral surface of the flexor digitorum profundus muscle.

THE FEMORAL NERVE

General Anatomy

The femoral nerve, which is the largest terminal nerve of the lumbar plexus, is formed by the fusion of fibers from the second, third, and fourth lumbar nerves and, sometimes, from the first. The fusion of these nerves begins and is completed with the substance of the psoas muscle, above or near the posterior brim of the pelvis, anterior to the transverse processes of the lumbar vertebrae, and medial to the quadratus lumborum muscle.

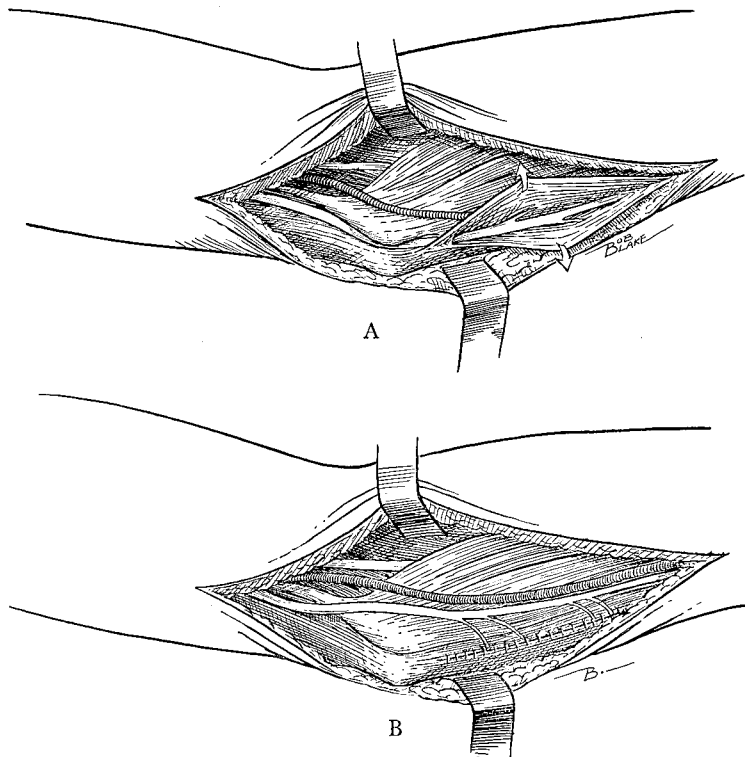

FIGURE 164.—Technique of anterior transplantation of ulnar nerve. A. Surgical exposure of nerve in condylar groove. B. Anterior transplantation of nerve. Suture of fascia of flexor carpi ulnaris.

The nerve passes downward and laterally, making a visible entry into the pelvis between the psoas and iliacus muscles a short distance above the inguinal (Poupart's) ligament. Here it lies lateral to the external iliac artery. It descends behind the inguinal ligament into the thigh, through the groove between the iliacus and psoas muscles, where it lies lateral to the femoral artery in the femoral trigone (Scarpa's triangle). Here it divides into superficial and deep terminal branches that supply the muscles and skin on the anterior aspect of the thigh. Collateral branches supply the iliacus and femoral artery before the nerve enters the thigh (fig. 165).

Terminal branches.—The femoral nerve has three superficial terminal branches, two motor and one sensory. A branch emerges from the femoral nerve trunk just below the inguinal ligament and passes medially between the femoral artery and the psoas muscle to the pectineus. Another twig follows the middle branch of the anterior femoral cutaneous nerve laterally to enter the sartorius. The anterior femoral cutaneous nerve, which is composed of middle and internal branches (fig. 166), supplies sensation over

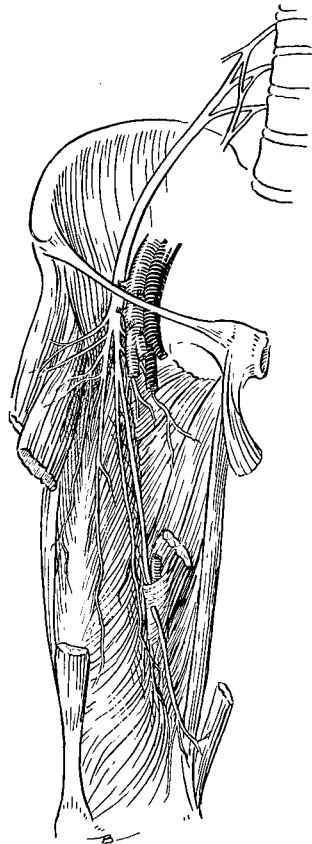

FIGURE 165.—Surgical anatomy of femoral nerve.

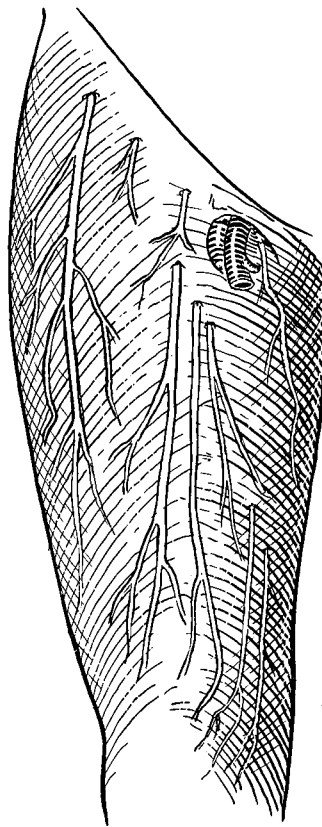

FIGURE 166.—Superficial cutaneous branches of femoral nerve.

the anterior and medial surfaces of the thigh down to the knee. One branch, the posterior, after anastomosing with the obturator in the adductor (Hunter's) canal, extends to the medial aspect of the mid calf.

The femoral nerve has six deep terminal branches, only one of which, the saphenous, mediates sensation. This nerve follows the femoral artery down to the adductor canal (fig. 165), which it traverses. Below the canal, the nerve passes between the sartorius muscle and the gracilis tendon, supplying a branch to the patella, and then continues down the leg in company with the great saphenous vein. At the ankle, the nerve courses anterior to the internal malleolus and continues into the medial side of the foot as far as the instep. The saphenous nerve supplies sensation to the medial side of the leg and foot. The motor branches, which are arranged medially to laterally, supply the vastus medialis, articularis genu (subcrureus), vastus intermedius (crureus), vastus lateralis, and rectus femoris. All of these motor branches branch promptly and frequently. Except for the branch to

the vastus medialis, which follows the saphenous nerve to the adductor canal, they are quickly lost in the substance of their respective muscles. Electrical stimulation is of great value in this region, in which easy anatomic identification is impossible.

Accessibility.—Because of its origin, course, and termination, the femoral nerve is the least accessible of the peripheral nerves. Arising as it does from short interlocking nerve roots within the substance of the psoas muscle, its first portion cannot be surgically exposed without grave damage to the surrounding tissues. The second portion, which extends from its pelvic appearance between the iliacus and psoas muscles down to the inguinal ligament lateral to the external iliac artery (fig. 167), is accessible through a suprainguinal, retroperitoneal approach. The most easily exposed length of the femoral nerve is its short third portion, which extends from the inguinal ligament to its terminal branching in the femoral trigone. The fourth portion consists of small terminal branches which, with the exception of the saphenous nerve, lie almost wholly within the subcutaneous tissues and muscles of the thigh. These branches are therefore difficult to expose except near their point of origin.

Surface Anatomy

The femoral nerve emerges from the psoas muscle at a point level with the anterior superior spine of the ilium. Its position in the thigh can be ascertained by palpating the femoral artery; it lies immediately lateral to this vessel, just beneath the inguinal ligament.

Surgical Approach

Positioning and preparation.—The patient lies supine for all exposures of the femoral nerve. Skin preparation includes the entire lower abdomen and the flank, groin, and thigh. Drapes are so applied that the entire leg on the involved side is included in the operative field, to permit easy flexion of the thigh. The thigh itself should be readily visible and palpable, to be available for electrical stimulation if it is necessary for identification of nerves. A folded pillow placed beneath the knee maintains relaxation of the femoral nerve and the adjacent muscles.

Exposure in the pelvis.—An oblique incision is made in the lower abdomen with the center level with, and $1\frac{1}{2}$ inches inside, the anterior superior iliac spine (fig. 168). The external oblique aponeurosis is divided longitudinally about an inch medial to the inguinal ligament (fig. 169A). The ilioinguinal and iliohypogastric nerves are identified and preserved. The fibers of the internal oblique and transversalis muscles are now separated in succession, exposing the parietal peritoneum (fig. 169B). By means of blunt dissection, the peritoneum is separated from the deep transversalis fascia laterally and posteriorly until the psoas muscle is reached.

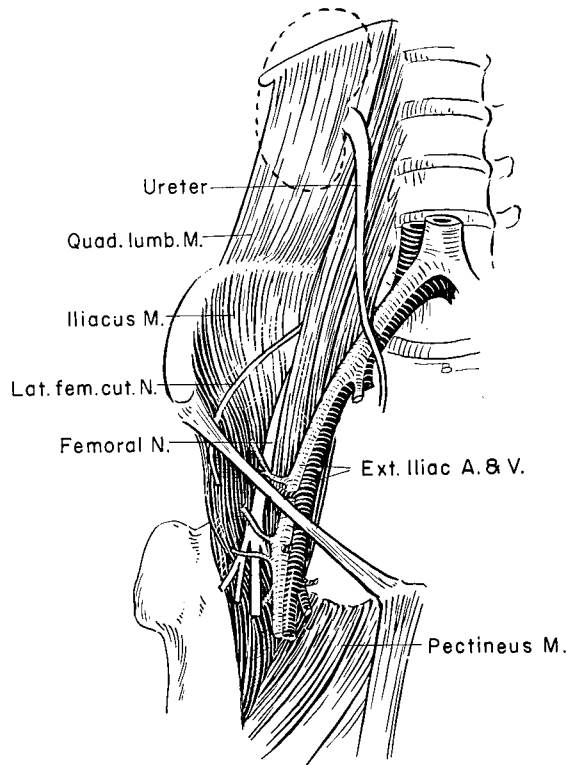

FIGURE 167.—Relation of femoral nerve to vascular structures at Poupart's ligament.

The femoral nerve will be found lying lateral to the external iliac artery and vein in the lower end of the surgical field (fig. 169C). It courses upward in the groove formed by the iliacus and psoas muscles. If these muscles are separated at the point at which the nerve deviates medially and becomes lost from view, an additional 2 to 2½ inches of nerve can be exposed. There is no objection to tracing the nerve as far as possible into the substance of the psoas.

The ureter crosses the psoas in the upper end of the wound. The genitofemoral nerve descends to the groin on the anterior surface of this muscle. The inferior epigastric and deep circumflex iliac vessels are situated anteriorly in the lower end of the wound. It is important to fix the position of all of these structures at the beginning of the dissection.

The nerve can usually be traced into the thigh, if that is necessary, without extending the incision. If, however, subinguinal incision is necessary, it is better made through a second incision paralleling the first. The integrity of the groin is thus not compromised.

If scarring prevents a retroperitoneal approach to the intrapelvic portion of the femoral nerve, the exploration can be accomplished transperitoneally.

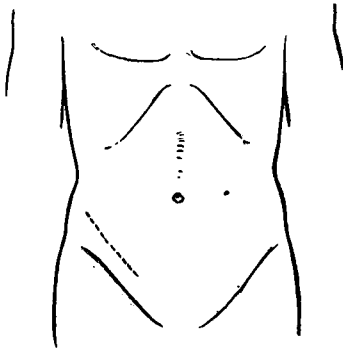

FIGURE 168.—Skin incision for exposure of intrapelvic portion of femoral nerve.

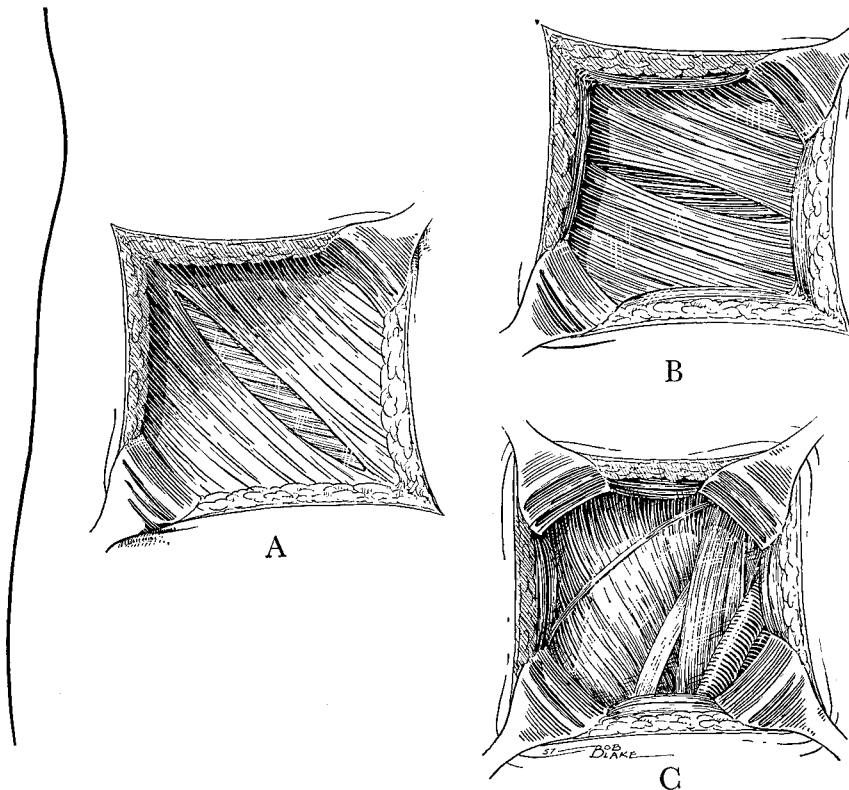

FIGURE 169.—Surgical exposure of femoral nerve in pelvis. A. Division of external oblique aponeurosis. B. Further dissection through fibers of transversalis muscle. C. Relation between femoral nerve and lateral femoral cutaneous nerve in pelvis.

Closure is effected in anatomic layers. The transversalis and internal oblique muscles are loosely reapproximated unless they coapt naturally; the sutures can be omitted. The external oblique aponeurosis is snugly sutured; if its leaves are thin and weak, they should be imbricated. The subcutaneous tissues and the skin are also sutured.

Exposure in the thigh.—The precise site of exposure of the femoral nerve in the thigh will depend not only on the level of injury but also upon the surgeon's judgment. As already pointed out, exploration of the femoral nerve below the femoral trigone is of dubious value because of the intramuscular course of small, finely divided nerves. If, however, exploration of isolated cutaneous or motor nerves is undertaken, the decision must be made on the merits of the case. Operation is on general surgical principles. Incision for repair of motor nerves is made with the recollection that their position corresponds to that of the muscle involved. Incision for repair of sensory nerves follows their anatomic course and is made with respect to flexion creases and the lines of Langer, in order to prevent keloid contracture.

Exploration of the femoral nerve in the femoral trigone is not required very frequently, at least for war wounds, probably because a wound of the femoral nerve in this area is usually associated with a severe wound of the femoral artery and vein, and the entire limb is lost. Exploration in this area was necessary only once, for causalgia, in more than 1,500 consecutive admissions to one neurosurgical ward in McCloskey General Hospital, Temple, Tex.

The femoral nerve in the trigone is exposed through an oblique subinguinal incision, with its center over the femoral artery (fig. 170). The lateral femoral cutaneous nerve may be encountered in the incision, and branches of the lumboinguinal nerve lie medially in the subcutaneous tissue (fig. 166). The great saphenous vein and its tributaries penetrate the cribriform fascia and enter the femoral vein through the fossa ovalis at the median end of the incision.

The cribriform fascia is opened obliquely downward, exposing the femoral trigone. The femoral nerve lies lateral to the femoral artery in a groove between it and the iliopsoas (fig. 171). Branches of the superficial epigastric and lateral circumflex arteries emerge from the lateral side of the femoral artery and cross the nerve. The terminal motor and sensory branches of the femoral nerve show considerable individual variation; they can be identified by the tissues they supply. If there is associated vascular damage, special precautions must be taken to prevent injury to the collateral blood supply.

Closure requires approximation of the cribriform fascia, the subcutaneous tissues, and the skin.

Methods of Gaining Length

The femoral nerve is under greatest tension when the back is arched and the thigh extended. Relaxation is maximal when the back and thigh are flexed. Gaps of 2½ to 3 inches can be overcome by flexing the back and thigh, with the knee flexed to relax the hamstring muscles. Subcutaneous rerouting of the nerve is of no value because the nerve would then describe an arc rather than a straight line. Deepening the groove between the iliacus and the psoas is of some little help because normally the nerve is somewhat curved and each end is situated more posteriorly than is the center. Branch stripping is of no help, with the possible exception of the branches to the pectineus, sartorius, and iliacus, all of which are terminal and emerge from the parent trunk in an almost straight line.

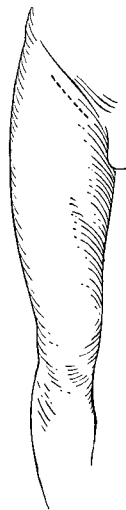

FIGURE 170.—Skin incision for exposure of femoral nerve in thigh.

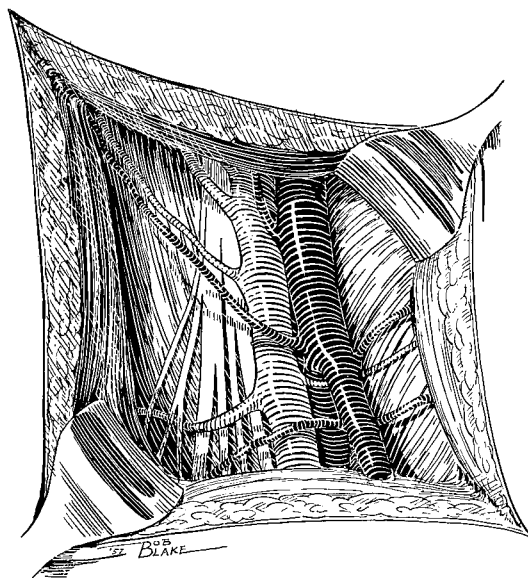

FIGURE 171.—Surgical exposure of terminal branches of femoral nerve in thigh.

THE SCIATIC NERVE AND ITS TERMINAL DIVISIONS

The sciatic nerve, which is the largest nerve in the body, arises from ventral and dorsal divisions of the fourth and fifth lumbar nerves and the first, second, and third sacral roots (fig. 172). Its trunk contains a tibial portion derived from the ventral divisions and a peroneal portion derived from the dorsal divisions.

The sciatic nerve leaves the pelvis by passing through the great sacrosciatic foramen and usually beneath, but sometimes through, the piriformis muscle. It then descends the posterior aspect of the thigh almost vertically

to the apex of the popliteal space. Here it divides into the tibial and the common peroneal nerves.

In its upper portion, the sciatic nerve lies approximately midway between the great trochanter and the tuberosity of the ischium. It is covered by the gluteus maximus muscle. It lies first upon the posterior surface of the obturator internus and gemelli muscles and then upon the quadratus femoris. From just below the lower border of the gluteus maximus to the popliteal space, the nerve lies upon the posterior surface of the adductor magnus, lateral to the semimembranosus. Here it is covered by the obliquely crossing belly of the long head of the biceps femoris muscle.

Division of the sciatic trunk into the tibial and common peroneal nerves most often occurs near the upper part of the popliteal space, but it may also take place at a higher level. In a small percentage of cases, division occurs within the pelvis itself. The sciatic nerve is then replaced by two distinct nerves. Even when the tibial and common peroneal components are incorporated in a single sheath, they are divided by a septum and can usually be separated from one another. The tibial portion occupies a ventromedial position in the sciatic trunk and the peroneal portion a lateral and somewhat dorsal position.

Branches in the thigh.—The nerve to the hamstrings, although at times it is incorporated within the sciatic trunk, is usually separated from it and should not be regarded as a branch of the sciatic. This fact explains why the hamstring muscles are almost always spared in injuries of the sciatic nerve, even in high lesions. The nerve to the hamstrings lies medial to the tibial portion of the sciatic nerve and divides into branches which innervate the semitendinosus, the long or ischial head of the biceps, the semimembranosus, and the dorsal portion of the adductor magnus. The short or femoral head of the biceps is supplied at about the middle of the thigh by a nerve which runs as a separate funiculus on the lateral border of the peroneal division of the sciatic nerve. This nerve may or may not be regarded by anatomists as a collateral branch of the sciatic nerve, depending upon the point of view. In any event, it must not be overlooked.

The tibial nerve.—The tibial nerve, after leaving the trunk of the sciatic nerve, descends in the thigh and crosses the popliteal space near its midline almost perpendicularly. At this level, it lies just beneath the fascia, dorsal and somewhat lateral to the popliteal vein, which itself lies dorsolateral to the popliteal artery. The tibial nerve then passes downward between the two heads of the gastrocnemius to lie deep or anterior to this muscle on the posterior aspect of the popliteus muscle. The nerve enters an arch in the soleus in company with the popliteal artery and vein. From this point, it descends in the leg as the posterior tibial nerve.

The tibial nerve gives off five muscular branches in the popliteal space. These branches supply, respectively, the two heads of the gastrocnemius, the plantaris, the soleus, and the popliteus muscles. Although they leave the

nerve at different levels, they have a common intraneural course, through a bundle which lies on the posterior aspect of the main nerve trunk. By careful dissection, they may be separated from the parent trunk for many centimeters above the points of their emergence.

The branches to the two heads of the gastrocnemius arise near the upper part of the popliteal space and diverge to enter the medial and lateral heads of the muscle. The nerve to the soleus arises at a lower level, passes deep or anterior to the lateral head of the gastrocnemius, and enters the soleus from its posterior aspect. This nerve sometimes emerges from the tibial in common with the branch to the lateral head of the gastrocnemius. The branches to the plantaris and the popliteus usually leave the main nerve separately at about this level. Articular branches are also given off to the knee joint, and vascular branches supply the anterior and posterior tibial and peroneal arteries.

In the popliteal space, the tibial division gives off the medial sural cutaneous nerve, which descends between the two heads of the gastrocnemius to the mid calf. Here it pierces the deep fascia and anastomoses with a communicating branch from the common peroneal nerve to form the sural or short saphenous nerve. The nerve supplies the skin over the posterolateral aspect of the lower third of the leg and the outer side of the foot and small toe.

The posterior tibial nerve.—In the calf, the posterior tibial nerve lies in a compartment in the intermuscular septum, deep to the soleus and on the posterior surface of the tibialis posticus muscle. As the nerve approaches the ankle, it occupies a groove between the flexor digitorum longus and the hallucis longus. It passes behind the medial malleolus and divides into its terminal branches in front of, and medial to, the tendo achillis. These branches, the medial and lateral plantar nerves, enter the sole of the foot. Throughout the leg, the posterior tibial nerve lies in close proximity to the posterior tibial artery and vein; it is posterior to the vessels in the upper calf and lateral to them from that point to the ankle.

Soon after its formation, the posterior tibial nerve gives off muscular branches to the lower portion of the soleus, tibialis posticus, flexor hallucis longus, and flexor digitorum longus. Articular branches are given off to the ankle joint, and a medial calcaneal branch supplies the skin on the posterior medial surface of the heel and on the posterior part of the sole of the foot.

The medial and lateral plantar nerves, which are the terminal branches of the posterior tibial, supply the intrinsic muscles of the sole of the foot. The medial plantar, which is the larger, gives branches to the flexor digitorum brevis, abductor hallucis, flexor hallucis brevis, and first lumbrical muscles. It supplies the skin over the medial aspect of the sole of the foot and over the dorsal surfaces of the medial three toes and the adjacent half of the fourth.

The lateral plantar nerve innervates the remaining muscles of the sole of the foot and the skin over the lateral aspect of the sole and the dorsal and plantar surfaces of the fifth toe and half of the fourth toe.

The common peroneal nerve.—The common peroneal nerve, when it leaves the sciatic trunk, descends through the lateral aspect of the popliteal space along the medial border of the biceps femoris muscle. It crosses the dorsal surface of the lateral head of the gastrocnemius, passes behind the head of the fibula, and then winds around its neck to enter a canal at the origin of the peroneus longus muscle. Here it divides into its terminal branches.

In the popliteal space, the common peroneal nerve gives off the communicating peroneal nerve, which descends on the posterior surface of the lateral head of the gastrocnemius, perforates the deep fascia on the back of the calf and unites with the anastomotic branch from the tibial to form the sural (short saphenous) vein. The lateral sural cutaneous nerve also arises from the peroneal nerve in the popliteal space, either as a separate branch, or, in common with the communicating peroneal nerve, to supply the skin over the posterior and lateral aspects of the leg.

As the common peroneal nerve passes through the peroneus longus muscle, it divides into superficial and deep peroneal nerves, and it also gives off the recurrent tibial branch. The superficial or musculocutaneous nerve emerges from beneath the peroneus longus muscle and descends the leg along the septum between this muscle and the extensor digitorum longus. It innervates the peroneus longus and brevis muscles and remains deeply placed to about the middle of the leg. Here it passes through the deep fascia and supplies the skin on the front of the leg and the dorsum of the foot.

The deep peroneal (anterior tibial) nerve, after emerging from the peroneus longus muscle, passes forward and downward, deep to the extensor digitorum longus muscle, to the ventral surface of the interosseus membrane. Here it descends in the leg in close apposition with the anterior tibial artery; it is deeply placed between the tibialis anticus muscle medially and the extensor hallucis and digitorum longus muscles laterally. The deep peroneal nerve passes deep to the tendon of the extensor hallucis longus onto the dorsum of the foot, where it divides into its lateral and medial terminal branches.

In the leg, the deep peroneal nerve supplies muscular branches to the tibialis anticus, extensor digitorum longus, extensor hallucis longus, and peroneus tertius muscles. Its lateral terminal branch innervates the extensor digitorum brevis muscle, and its medial terminal branch sends dorsal digital cutaneous nerves to the adjacent aspects of the great and second toes.

The tibial recurrent nerve, which is the smallest of the three branches of the common peroneal nerve, is usually the first to leave the main trunk. After passing beneath the peroneus longus muscle, it sends motor branches to the upper portion of the tibialis anticus muscle and also sends articular branches to the knee joint.

Surgical Exposure of the Sciatic Nerve

Positioning and preparation.—The patient lies prone. An attendant, standing on a stool, elevates the foot and raises the thigh from the table, to facilitate the skin preparation, which should include the skin of the buttock and lower back if there is any chance that it may be necessary to reflect the gluteus maximus muscle. The entire leg is also included in the preparation.

A sterile sheet is passed beneath the leg and thigh. The foot and ankle are wrapped in stockinet and then in a small sheet which is secured with a bandage. The upper part of the leg is draped, provision being made for exposure of the buttock on the affected side. A laparotomy sheet, with the entire exposed limb thrust through the opening, can be used to advantage. The draping described permits free mobility of the whole limb, which is essential, especially if neurorrhaphy is necessary and the leg must be fixed in flexion at the knee at the time of suture, to make up the nerve gap, and maintained in this position after operation.

Exposure beneath the gluteus maximus muscle.—The question mark or inverted question mark incision used in World War I is employed for exposure of the sciatic nerve beneath the gluteus maximus muscle (fig. 173A). The objective of the incision is to expose the nerve throughout its course from the sciatic notch into the thigh, with a minimum of injury to muscle fibers and blood vessels. To accomplish this, it is necessary to divide the tendon of insertion of the gluteus maximus muscle, so that the muscle can be reflected medially with its nerve while the blood supply is left intact.

A curved incision, beginning at the posterior iliac spine, circles the border of the buttock downward and outward to the inner portion of the greater trochanter. The incision then curves downward and inward along the lower border of the gluteal fold to the midpoint of the thigh. It can be extended vertically downward as far as is necessary. The deep fascia is exposed and divided in the line of the incision (fig. 173B). A finger is passed beneath the fascia, and the muscle is traced laterally to its insertion. It is divided a few centimeters from its bony attachment. At the upper limit of its insertion, the muscle is split in the direction of its fibers to the upper medial angle of the skin wound. The whole muscle is now reflected medially, care being taken to avoid injury to the inferior gluteal vessels and nerves which lie on its deep surface. The small sciatic nerve, which crosses the gluteal fold near its midpoint, must also be protected. Particular care must be used in reflecting the muscle, as not infrequently it is adherent to the underlying structures and even to the sciatic nerve trunk itself as a result of penetrating wounds in this region.

When the muscle is reflected, the sciatic nerve, the small sciatic nerve, and the nerve to the hamstrings are exposed as they emerge from the sacro-sciatic foramen beneath the piriformis muscle. Since this muscle may be

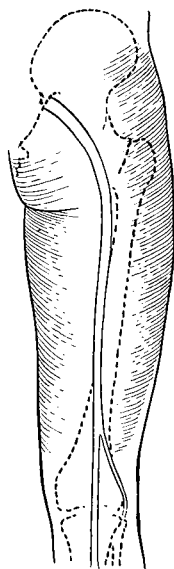

FIGURE 172.—Schematic drawing of sciatic nerve showing origin, course, and main branches.

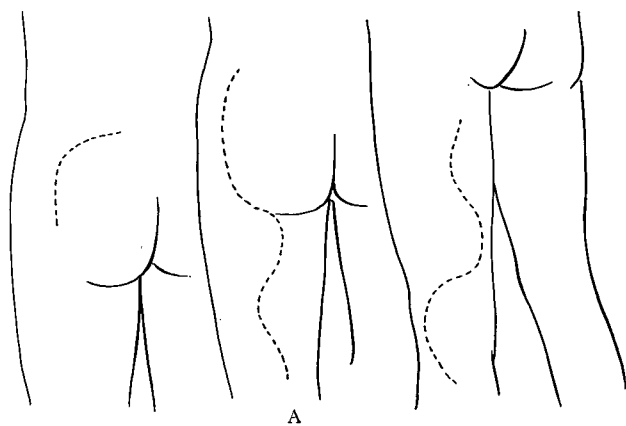
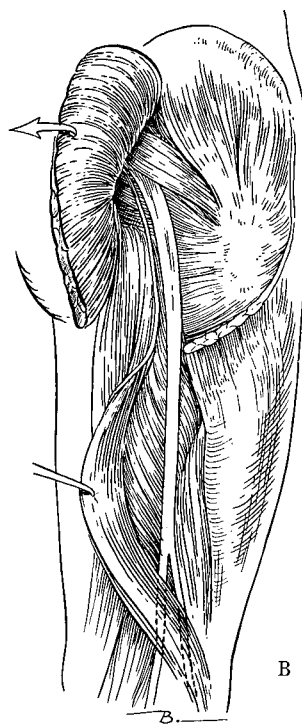

FIGURE 173.—Anatomic approach to sciatic nerve. A. Outline of skin incisions in hip and thigh. B. Division of gluteus maximus at tendinous insertion to expose sciatic nerve in buttock and upper thigh.



incorporated in the main sciatic trunk or lie to its medial side, an attempt should be made to identify it at this stage by electrical stimulation. The small sciatic nerve should also be identified by tracing it downward to its superficial position beneath the gluteal fold. When the piriformis muscle is retracted upward, the sciatic nerve can be traced higher for a short distance. If further exposure is necessary, the tendon of the piriformis may be divided and the muscle reflected medially.

The wound is closed in the usual fashion, care being taken to secure firm suture of the tendon of insertion of the gluteus maximus. Particular care is necessary, in closure of the wound of the thigh, not to incorporate the small sciatic nerve in the suture line, since this error could give rise to troublesome postoperative pain. This nerve lies in close relation to the deep fascia and may easily escape notice.

In certain injuries to the sciatic nerve beneath the gluteus maximus, it is not necessary to divide the tendon of insertion of this muscle. This is particularly true when only a neurolysis is indicated. In injuries of the nerve near the sacrosiatic notch, adequate exposure may be obtained by utilizing the upper portion of the question mark incision, between the trochanter and the posterior inferior iliac spine. The lower third of the nerve beneath the gluteus maximus can be exposed by retracting the lower border of the muscle upward and dividing only the lowermost fibers of its tendinous attachment.

Exposure in the thigh.—The sciatic nerve can be exposed in the thigh by a midline dorsal incision extending from the gluteal fold to the popliteal space (fig. 174). An incision limited to this region may be adequate for lesions in the upper third of the thigh. If a gap of several centimeters in the nerve requires neurorrhaphy, length can be gained by exposing the nerve with its tibial and common peroneal branches through a separate incision in the popliteal space. In the upper third of the thigh, the incision is made through the deep fascia, care being taken to avoid the posterior femoral cutaneous nerve, which lies in close relation to the fascia.

Immediately below the inferior margin of the gluteus maximus muscle, the sciatic nerve, which here is covered only by skin and fascia, lies along the lateral border of the biceps. When this muscle is retracted medially, the nerve is brought into view and can be traced downward to the mid thigh, where it lies deep to the biceps. It can be followed into the buttock by retracting upward the lower border of the gluteus maximus. During the exposure of the sciatic nerve in the thigh, care must be taken to preserve the branches to the hamstring muscles which lie to the medial side of the nerve. A branch to the short head of the biceps, lying to the lateral side of the nerve, must also be avoided.

Below the upper third of the thigh, the sciatic nerve is exposed by retracting the biceps muscle laterally and the semimembranosus and semitendinosus muscles medially.

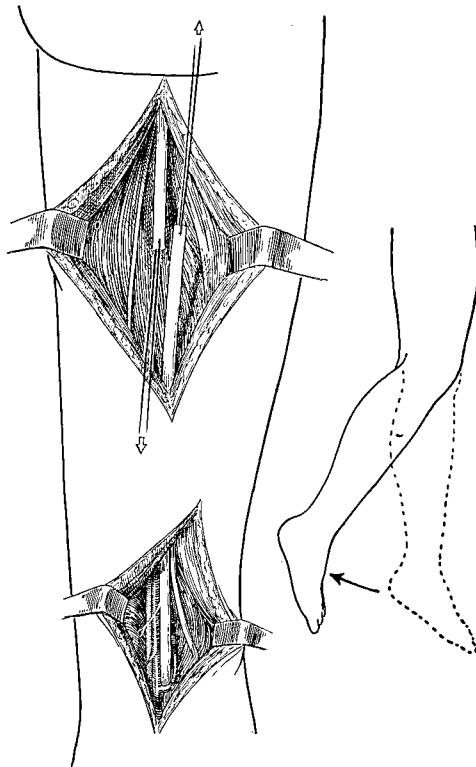

FIGURE 174.—Exposure of sciatic nerve in mid thigh and popliteal space to show technique for gaining length.

Near the apex of the popliteal space, the nerve divides into the tibial and common peroneal portions. The common peroneal nerve is readily identified by palpation as it passes along the medial border of the biceps in the popliteal space. It constitutes the lateral portion of the sciatic nerve and can easily be differentiated from the tibial portion, from which it is separated by a fibrous septum. It is important to identify each component when the sciatic nerve has been divided, so that there will be no crossing of the components during suture. Technical considerations are discussed elsewhere, under a separate heading (p. 362).

Surgical Approach to the Terminal Divisions of the Sciatic Nerve

Exposure of the tibial and common peroneal nerves in the popliteal space.—In order to expose the tibial and common peroneal nerves in the popliteal space, the longitudinal midline incision used to expose the sciatic nerve is extended directly downward through the popliteal space to just above the flexion creases. Here it is curved sharply laterally, to avoid crossing the

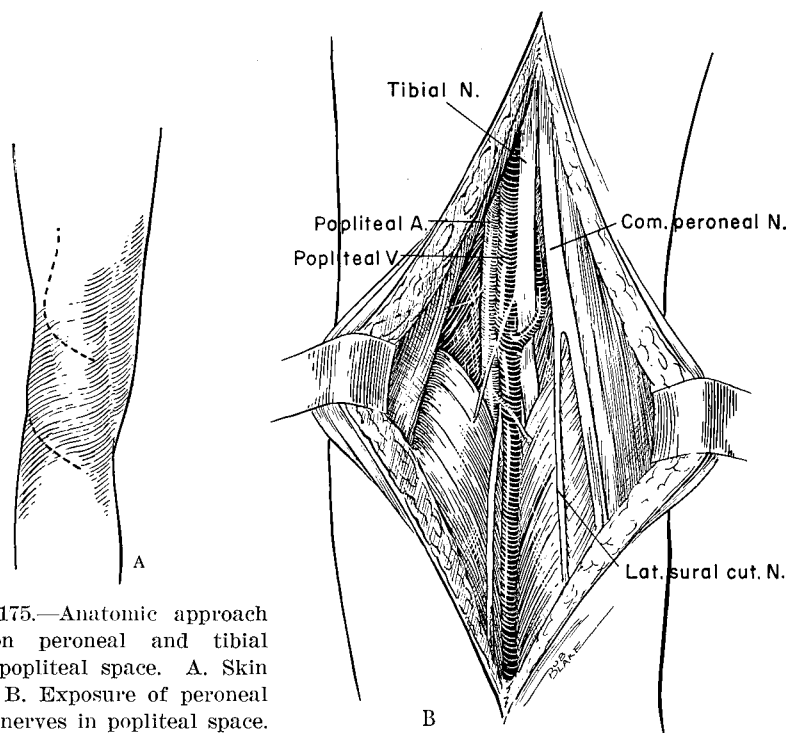

FIGURE 175.—Anatomic approach to common peroneal and tibial nerves in popliteal space. A. Skin incisions. B. Exposure of peroneal and tibial nerves in popliteal space.

creases perpendicularly (fig. 175A). The incision is then continued downward to the neck of the fibula and is carried forward along the course of the peroneal nerve as it enters the peroneus longus muscle.

The deep fascia is exposed and divided in line with the incision (fig. 175B). The common peroneal nerve can now be traced (1) upward to the level at which it unites with the tibial nerve to form the sciatic trunk and (2) downward to its entrance into the peroneus longus muscle. If it is desired, the tibial nerve may be exposed first. It can usually be found with ease as it enters the apex of the popliteal space from beneath the biceps, or as it leaves the space deeply between the two heads of the gastrocnemius muscle.

In the popliteal space, the tibial nerve is surrounded by fat and is crossed by several small vessels, which may be divided. This nerve lies dorsal and slightly lateral to the popliteal vein, which has a similar relation to the more deeply placed popliteal artery. The tibial nerve can be exposed in the lower portion of its course by retracting the two heads of the gastrocnemius. This maneuver will expose the nerve as it lies upon the popliteus muscle, just before it enters an arch in the soleus muscle to become the posterior tibial nerve.

The muscular and sensory branches given off from the tibial and common peroneal nerves at this level have been identified earlier in this chapter

(pp. 352, 353). The individual branches are identified and preserved. By careful dissection, they may be separated from the parent trunk for many centimeters to gain length in overcoming large gaps in the nerves.

Exposure of the posterior tibial nerve.—A large gap in the posterior tibial nerve may be overcome, even when it occurs at the ankle, by mobilizing the tibial and posterior tibial nerves and their branches. Mobilization requires exposure of the tibial nerve in the popliteal space (p. 357), as well as of the posterior tibial nerve throughout the greater part of its course. Free mobilization of the posterior tibial nerve beneath the soleus muscle, which is usually essential to gaining length at the ankle, requires division of the lower half of the medial tibial attachment of the soleus muscle. For the operation, the patient lies semiprone, with a pillow beneath the pelvis on the side opposite the leg to be operated on (fig. 176A).

The posterior tibial nerve is exposed in the lower two-thirds of the leg through a longitudinal incision that starts midway between the tendo achillis and medial malleolus and ascends the leg parallel with, and about an inch posterior to, the tibia (fig. 176B). Care must be taken to avoid the internal saphenous vein and the medial sural nerve.

The deep fascia is divided in line with the incision. A fascial plane is identified between the soleus, gastrocnemius, and flexor digitorum longus muscles. Incision is made in this plane, and the gastrocnemius and soleus muscles are retracted laterally. The neuromuscular bundle containing the posterior tibial artery, with its venae comites and nerve, is brought into view as it lies under the deep layer of the fascia cruris on the posterior surface of the posterior muscle in a groove between the flexor digitorum longus and flexor hallucis longus muscles. After the fascia has been opened, the nerve is carefully dissected away from its vessels, and a wide elastic band is placed about it to serve as a retractor. The nerve can now be dissected downward to the ankle and upward to the level at which the attachment of the soleus interferes with further direct visualization. If there is much scar tissue, venous bleeding is often troublesome and ligation may be necessary to control it.

The incision to expose the posterior tibial nerve in its upper third is carried medially over the attachment of the soleus. The lower half or lower two-thirds of the attachment is divided about 1 cm. medial to its tibial attachment and is retracted laterally, to bring the nerve into view. If local mobilization does not provide sufficient length, the incision can be extended upward to expose the tibial nerve in the popliteal space. A separate incision for mobilization of the tibial nerve is frequently adequate. Whichever incision is used, care must be taken to have it cross the midpopliteal space parallel to the flexion creases and not at right angles to them.

Closure is accomplished in the usual fashion. The attachment of the soleus muscle should be firmly sutured. In closure of the fascia, care must be taken not to injure the medial sural nerve.

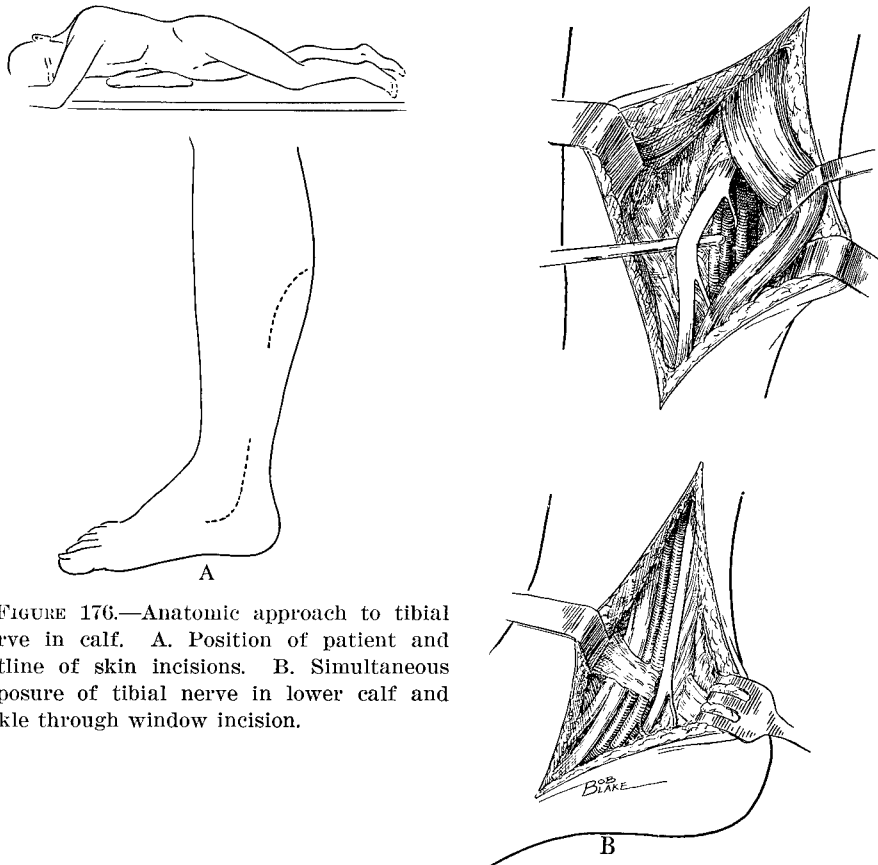

FIGURE 176.—Anatomic approach to tibial nerve in calf. A. Position of patient and outline of skin incisions. B. Simultaneous exposure of tibial nerve in lower calf and ankle through window incision.

Exposure of the common peroneal nerve below the popliteal space.—

To expose the common peroneal nerve and its branches after the nerve leaves the popliteal space, the incision used for exposure in the popliteal space is continued downward and forward across the neck of the fibula and then down the anterior aspect of the leg along the course of the extensor digitorum longus muscle (fig. 177A). The nerve is identified by palpation along the medial border of the biceps tendon as it crosses the lateral head of the gastrocnemius. The deep fascia may be opened at this point and the nerve traced downward as it passes posterior to the head of the fibula and winds around its neck. As the nerve crosses the fibula, it is somewhat flattened and is covered by a connective tissue layer consisting of deep fascia and a lateral expansion of the biceps tendon. When this layer of connective tissue is opened, the nerve, which lies immediately beneath it, can be traced downward and anteriorly to its point of entry into the peroneus longus muscle. This muscle can now be opened to expose the nerve as it passes through the muscle to divide into its terminal branches (fig. 177B).

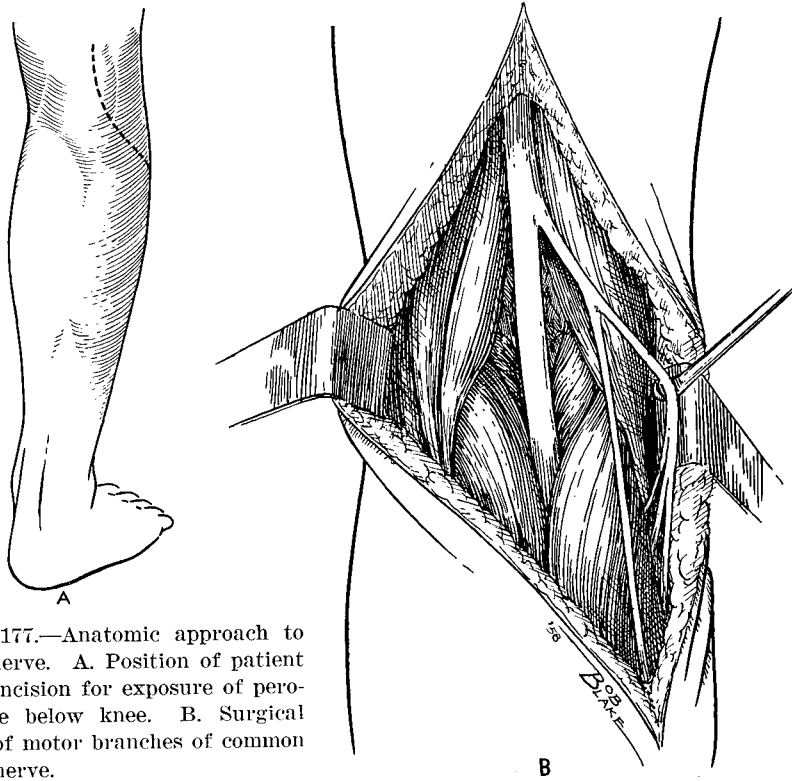

FIGURE 177.—Anatomic approach to peroneal nerve. A. Position of patient and skin incision for exposure of peroneal nerve below knee. B. Surgical exposure of motor branches of common peroneal nerve.

The common peroneal nerve in the popliteal space consists of two large bundles. The more dorsal and lateral bundle continues through the peroneus longus muscle as the superficial peroneal (musculocutaneous) nerve. This nerve descends the leg along the septum between the peroneus longus and extensor digitorum longus muscles. In its upper third, it is deeply placed and gives off branches to the peroneus longus and brevis muscles. At the junction of about the middle and lower third of the leg, the superficial peroneal nerve will be found lying upon the peroneus brevis muscle; immediately thereafter it passes through the deep fascia to supply the skin of the front of the leg and the dorsum of the foot.

The other large bundle in the common peroneal nerve continues through the peroneus longus muscle as the deep peroneal (anterior tibial) nerve. As it passes through this muscle and forward, deep to the extensor digitorum longus muscle, it gives off branches to these muscles and to the tibialis anticus. It is usually impractical to follow the common peroneal nerve beneath the extensor digitorum longus muscle unless the wound is in this region and involves the muscular branches. It is only occasionally possible to suture the terminal branches at this level.

In the lower third of the leg, both the deep and the superficial peroneal nerves can be exposed through a longitudinal incision over the extensor digitorum longus muscle, about midway between the tibia and the fibula. The deep peroneal nerve is exposed by incising the deep fascia and opening the cleavage plane between the extensor digitorum longus and the tibialis anticus muscles. The nerve lies deep between the latter muscle and the extensor hallucis longus within the neurovascular bundle, in close apposition with the anterior tibial artery. Exposure of the deep and superficial peroneal nerves is seldom indicated except in certain instances in which pain in the foot requires relief.

Methods of Gaining Length

The sciatic nerve and its major branches are under greatest tension when the thigh is flexed, adducted, and internally rotated and the leg is extended. Relaxation is maximal when the thigh is extended, abducted, and externally rotated and the knee is sharply flexed. Defects in the sciatic nerve up to 6 inches can be bridged by thus positioning the lower extremity. Gaps of $2\frac{2}{5}$ to 4 inches in the tibial or peroneal nerve can be closed at the knee by simply flexing the knee, and additional length can be gained by transplanting the nerve to a subcutaneous position. An additional $\frac{2}{5}$ to $\frac{4}{5}$ inch can be gained in the peroneal nerve by removing the head of the fibula. Defects up to $4\frac{4}{5}$ inches in the posterior tibial nerve at the ankle can be closed by combining the advantages of wide mobilization, nerve stripping, and positioning.

It was the general military experience that soldiers with injuries of the lower extremity who practiced preoperatively until they were able to touch their hands to the floor with legs extended were better prospects for suture repair of the sciatic nerve and its branches than were those who had not thus become supple and relaxed.

CHAPTER XV

Techniques of Peripheral Nerve Repair

Benjamin Bradford Whitcomb, M.D.

GENERAL CONSIDERATIONS

The techniques described in this chapter are chiefly those used in neurosurgical centers in the Zone of Interior and overseas during World War II. They were arrived at by a process of evolution, it is true, but they were based on classical, well-established principles of nerve repair. As is always necessary in a military program, the procedures were standardized, but, so long as the fundamental principles were followed, minor modifications, to fit special circumstances, were both permitted and encouraged.

All operations at neurosurgical centers were performed by, or under the supervision of, qualified neurosurgeons. Peripheral nerve surgery cannot be undertaken lightly. The surgeons who perform it must be qualified technically, but they also must have a proper background of neuroanatomy, neurophysiology, and neuropathology. With this knowledge, the timing of repair of nerve injuries is on a rational basis and is related to the nature and extent of the injury.

The categories of nerve injuries employed in World War II were as follows:

1. Fresh wounds produced by some sharp instrument, such as a razor. These wounds, which resembled the type of injury seen in civilian life, were not combat incurred. Because they were generally clean, they could be repaired at once, through a relatively small incision. When the nerve ends were trimmed back a few millimeters to obtain flush surfaces for approximation, the delicate epineurium held sutures well, since tension was minimal or absent.

2. Wounds similarly produced by some cutting agent, but grossly contaminated. In such injuries, extension of the incision was necessary to accomplish adequate repair. The best plan was to leave the wound open and repair the nerve a week or so later, at the time of delayed primary wound closure. In these circumstances and with this timing, extension of the incision was safer, and the epineurium was more suitable for suture.

3. Combat-incurred injuries from high-velocity missiles. Nerve injuries of this kind were associated with more or less extensive wounds of the soft tissues, to which first attention had to be given. These wounds were in no way comparable with the nerve injuries generally observed in civilian prac-

tice. Even when the nerve was completely severed, it was not possible to determine the precise extent of damage immediately after the injury. Furthermore, in the face of the contamination always present in a combat-incurred wound, and, in many instances, the infection already established, immediate nerve repair was not safe.

The policy was therefore developed of treating the soft-tissue wound by the usual techniques of debridement and delayed primary wound closure and deferring repair of the nerve injury until at least 3 weeks had elapsed. At the end of this time, histopathologic processes were sufficiently established for the surgeon to be able to demonstrate grossly the amount of proximal and distal resection which would be necessary for satisfactory suture. In the meantime, the soft-tissue wound would have healed successfully; antibiotic therapy would have been used prophylactically or therapeutically; and the epineurium would have become sufficiently strong to hold sutures, even if some tension were present. At the preliminary operation, however, nothing was done to the nerve except to investigate and record its status and, perhaps, approximate the severed ends with a tantalum sling suture.

A great deal was gained by the delay of 3 weeks or more after injury before nerve repair was attempted. Delay, however, could not be indefinite. If the repair operation was postponed more than 3 months, results became progressively less good from loss of muscle substance and the accompanying fibrotic process. According to Bowden and Gutmann,¹ detectable function is still possible if nerve repair is delayed as long as 3 years, but it would be unreasonable to expect it to be useful.

4. Combat-incurred wounds in which nerve trauma was associated with serious bone, vascular, or soft-tissue loss. Special techniques of repair were required in such injuries, though the general principles just outlined were always followed; that is, adequate debridement, delayed primary wound closure, and delayed nerve repair.

5. Closed injuries in which nerve damage was associated with fractures, traction or stretch palsies, and paralysis resulting from ischemia. This category of injuries provided the most formidable problem which faced the military surgeon who was called upon to repair peripheral nerves.

ARRANGEMENT OF OPERATING ROOM

Operations for the repair of peripheral nerve injuries, particularly those in which there were associated injuries and considerable scarring, often lasted for several hours. A good deal of apparatus was required in addition to the usual surgical instruments, and additional personnel were frequently necessary. Ideally, peripheral nerve surgery was performed in a large operating room, not only to eliminate the discomforts of crowding but also to avoid the risk of contamination almost inevitable with crowding.

¹ Bowden, R. E. M., and Gutmann, E.: Degeneration and Re-Innervation of Human Voluntary Muscle. *Brain* 67: 273-313, December 1944.

The length of the operation meant that the comfort of the patient and of the surgeon and his assistants was a practical consideration. The patient was placed on a suitable mattress, and special attention was paid to making such positioning as was required as comfortable as possible. When the injury was in the upper extremity, the arm was placed on a padded board, which extended at about right angles to the table.

The surgeon and his assistants sat on stools of the proper height, and the instrument tables and other apparatus were located with due regard for their convenience.

Illumination was provided from fixed overhead lights, preferably supplemented by movable spotlights. These lights were almost essential for operations in certain sites. For work on a flexed extremity, for instance, in which precise approximation of the nerve ends was to be attempted, the ordinary reflector type of overhead light did not provide sufficient illumination.

Instruments and apparatus.—The basic instruments of the usual dissecting set were suitable for peripheral nerve repair (fig. 178), with the proviso that all of them be delicate and fine. Nerve hooks were essential. The fine-toothed iris forceps was found to be an ideal instrument for handling delicate epineurium. Fine suture material was supplied on atraumatic needles.

The Greenwood bipolar electrocoagulation forceps was excellent for achieving hemostasis near nerve trunks; when it was used, there was no spread of heat to surrounding tissues, as there was when unipolar electrodes were used in conjunction with a ground plate attached to the patient's body. Only fine-pointed forceps were used, so that the mass of tissues to be coagulated between the points was held to a minimum.

Fibrin foam or Gelfoam with thrombin was of great value in accomplishing hemostasis in beds of scar tissue or in the nerve trunk itself, both being areas in which ligatures were not practical and electrocoagulation was contraindicated.

An essential piece of apparatus in peripheral nerve surgery was the inductorium or electric nerve stimulator. Many models of this instrument were available, some more complicated than others, but the only essential was a weak faradic stimulation through a fine needlepointed bipolar electrode. Some types of stimulator could withstand sterilization by heat, and others were sterilized by cold or wet sterilizing solutions. When wet sterilization was employed, the electrodes were thoroughly rinsed and the contacts dried before use. Their terminals of application were kept in glass containers until they were needed; large test tubes were satisfactory.

PREOPERATIVE PREPARATION

No matter how thorough the preoperative study had been, it was always a wise precaution for the surgeon, the day before operation was scheduled, to make a second objective survey of the patient's status, with particular

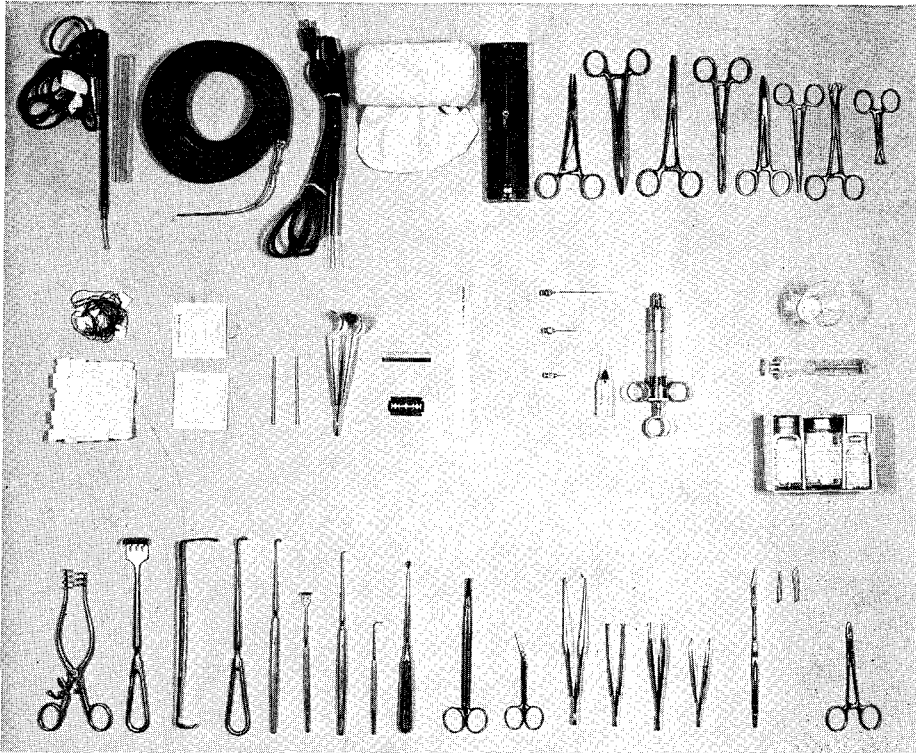

FIGURE 178.—Instruments for use in peripheral nerve surgery. Top row, left to right: cord and applicator for electrosurgical unit; controlled suction tip with noncollapsible rubber tubing; bipolar electrode with cord for nerve stimulation; sterile stockinet roll; silver clip cartridge; clip applicator; large curved hemostat; Kocher forceps; Allis forceps; small curved hemostat; mosquito hemostatic forceps towel clips (two sizes). Middle row: cottonoid strips and small pledgets with suture attached; tantalum wire size 0.005 and 0.003 swaged into fine curved needles; blades; metal rule; needles; Novocain and Novocain syringe; fibrin foam with thrombin and isotonic saline with syringe and medicine glass for preparation. Bottom row: self-retaining retractor; blunt rake retractor; Army retractor; vein retractor; nerve retractor; small rake retractor; nerve hooks (large and small); curette scissors; iris scissors; bayonet forceps; small-toothed forceps; dural forceps; fine-toothed iris forceps; long knife handle with assorted blades; small needle holder.

reference to any paralysis present. In peripheral nerve injuries, particularly in early cases, the dramatic changes which sometimes occurred in the course of a few days could radically alter the planned operation or even eliminate the need for surgery.

Preoperative preparation followed standard practices, with special measures employed only if they were indicated. Some surgeons thought it advisable, in operations on the sciatic nerve, to have the plaster fixation cast to be used after operation prepared beforehand. The cast was bivalved and

padded and was thus ready for immediate application at the end of the operation.

Skin preparation.—Preparation of the skin, which began the night before operation, included a wide area around the planned incision. If the wound was in an extremity, as it usually was, the entire limb was shaved and scrubbed with soap and water. Many surgeons preferred an orthopedic preparation, in which, after the usual cleansing measures, the skin was additionally cleaned by alcohol and ether and was then wrapped in sterile towels. There was not universal agreement on the need for these additional measures, except when a combined attack on nerve and bone was planned. On the other hand, it was taught and practiced that the availability of effective antibiotic and chemotherapeutic agents did not release the surgeon from the necessity of painstaking skin preparation, in view of the extensive and prolonged exposure necessary in peripheral nerve surgery.

In the operating room, the extremity was thoroughly scrubbed with soap and water, this cleansing, like all other measures, going well beyond the area of the planned incision. Alcohol and ether were then applied, followed by some colored antiseptic with fat solvent properties. The phenol coefficient in the antiseptic was regarded as of less importance than the coloring, which indicated the area of skin which had been prepared.

If the lower extremity had to be prepared, as in exploration of the sciatic nerve, it was usually held by an assistant or suspended from a standard by means of a towel about the ankle. The patient himself frequently cooperated in maintaining the extremity in the desired position. If the operation was to be on the upper extremity, the prepared hand was usually covered by a rubber glove or sterile towel.

Draping.—After the extremity had been prepared, it was placed on sterile drapes of waterproofed material or on several thicknesses of ordinary sterile drapes. A roll of stockinet was then used to encase the limb like a stocking.

Certain general principles were followed in draping the patient. The sterile field was completely isolated. The drapes were so arranged as to permit free movement of the joints adjacent to the injury, with due regard to the probable position of the extremity at the time of closure. The patient's face was left exposed, so that there would be no interference with his breathing. An arm was left exposed, so that the anesthetist could determine the blood pressure and pulse and administer intravenous fluids and medication as necessary. Heavy drapes were supported on instrument stands or on standards; a great deal of fluid could be lost from perspiration in the course of the operation if this precaution were not taken.

The reflection of light from white drapes could become extremely trying to the surgeon and his assistants during long operations, and colored drapes, preferably dark green or gray, were used whenever possible (fig. 179).

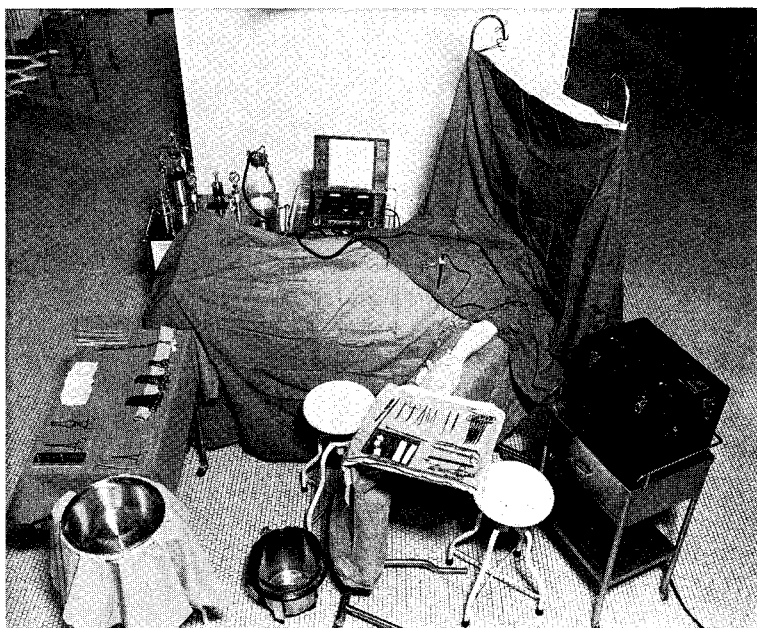

FIGURE 179.—Arrangement of instruments and apparatus for peripheral nerve surgery. Suction machine, inductorium, and electrocautery apparatus are on the far side of the patient, with their respective leads available to the operative field.

ANESTHESIA

Regardless of the anesthetic used, an anesthetist was always present, not only to administer anesthesia as necessary but also to follow the condition of the patient by regular determinations of the blood pressure, pulse, and respiration and to administer intravenous fluids and medications. With an anesthetist present, the surgeon need not restrict himself to the use of any single agent but could employ whatever combination he might wish to secure balanced anesthesia.

Preoperative preparation included the administration of a barbiturate, morphine, and atropine in the dosages appropriate to the individual case.

Local infiltration anesthesia.—Local infiltration anesthesia, achieved with 0.5- to 1.0-percent solutions of procaine hydrochloride (Novocain) or piperocaine hydrochloride (Metycaine hydrochloride), was the anesthesia of choice in peripheral nerve surgery; it was essential until the status of the affected nerve had been fully evaluated. It had many advantages. While the nerve was being tested, the patient's cooperation, as just indicated, was essential in recognizing sensory stimuli from the distal segment. If the sheath was opened, the relative content of sensory and motor fibers in the funiculi could also be recognized. Local anesthesia has a hemostatic effect in the surgical field. It was always adequate when correctly administered.

The patient's postoperative condition was better after local than after general anesthesia, and he could take fluid and food at once.

The chief disadvantage of local anesthesia was, as always, that it had to be repeated at intervals during the operation, particularly into the subcutaneous tissues. Whatever agent was employed was given under direct vision. No injection was made into the nerve until stimulation and evaluation had been completed.

Regional anesthesia.—Regional anesthesia was not employed in peripheral nerve surgery. It had no real advantages over local or general anesthesia, and it was useless in testing the sensory components of the damaged nerve. Furthermore, unless it was administered by experts, brachial plexus and sciatic nerve blocks sometimes damaged these nerve trunks, principally because the trauma produced bleeding in or about them. Finally, if the operation was prolonged, regional anesthesia was not sufficient and had to be supplemented by local infiltration anesthesia.

Spinal anesthesia.—Continuous spinal anesthesia was ideal for repair of peripheral nerve injuries in the lower extremity after the distal segments had been stimulated and the status of the nerve evaluated. Since many sciatic lesions were only partial, the importance of recognizing the intact fibers is obvious. The status of motor fibers can be determined under any variety of anesthesia, but intact sensory fibers, as already emphasized, can be determined only with the cooperation of the patient. As soon as the status of the nerve had been determined, a local anesthetic agent was instilled through a needle already placed in the spinal canal. Ideal anesthesia was thus assured for the remainder of the operation.

General anesthesia.—General anesthesia was achieved by the intravenous or inhalation techniques. Intravenous anesthesia with thiopental sodium (Pentothal sodium) was used as a supplement to local infiltration anesthesia or spinal anesthesia when the patient became apprehensive or uncomfortable from prolonged positioning. Inhalation anesthesia was chiefly used for the same reasons, particularly when prolongation of the operation would require the use of Pentothal sodium in amounts which exceeded safe limits.

INCISION AND EXPOSURE

Incision.—The operative incision was planned before operation, not after the patient had been placed on the operating table. The fundamental approaches for each peripheral nerve employed during World War II were based on previous developments and wartime experience. These standard approaches were anatomically sound. Due regard was paid to anatomic considerations as well as to the principles of plastic surgery. Flexion creases, for instance, were not vertically crossed (fig. 180), and as far as possible the cutaneous nerve and vascular distribution was always preserved.

The site of the incision in combat-incurred wounds was necessarily affected by the location and extent of the scar of the original injury. The

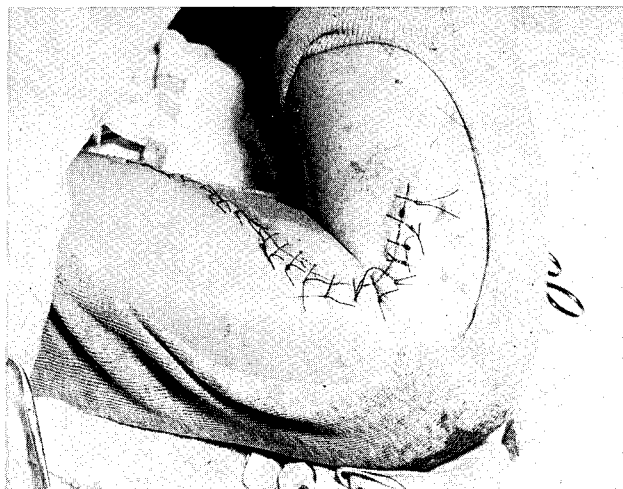

FIGURE 180.—Closure of lateral incision for injury of peroneal nerve. Note that incision does not cross flexion crease of knee and this facilitates suture with the knee flexed.

distortion inevitable as the result of scarring frequently made exposure difficult. The scar was usually attached to underlying tissues, and, if it did not require removal because of its interference with the function of the underlying muscles or vascular supply to a nearby incision, its excision was usually indicated for cosmetic reasons. Whenever possible, the site of excision was incorporated into the surgical incision, in order to preserve maximum blood supply to the skin (fig. 181).

The incision was large enough to permit mobilization of the nerve segments under full vision. If the nerve defect was extensive, the incision was extended to permit not only mobilization of the segment but also careful dissection of the functioning branches (fig. 182). Blind stripping of these branches by traction on the nerve segments through a small incision was always harmful.

The margins of the incision were protected by towels, not only to protect them against contamination and for hemostatic purposes but also to keep the skin edges from drying during long neurosurgical procedures.

Dissection.—Dissection to expose the injured nerve was carried out gently and carefully between the normal muscle planes of cleavage, with due regard to protection of the muscle bellies and their nerve and blood supply. It was occasionally necessary to split a muscle in the direction of its fibers or to detach it from its insertion or tendinous point of origin by cutting through the tendinous portion, but it was almost never necessary to cut across the muscle fibers themselves.

The nerve involved was identified both above and below the point of injury and the surrounding scar, in which recognition of structure was



FIGURE 181.—Typical scars of healing by granulation following debridement. Resections of the entire scar must be planned for in incisions for nerve repair. A. Wide scar overlying nerve injury in upper arm. Modified Z-plasty incision is indicated. B. Contracted scar in median and ulnar nerve injury of upper arm. This scar is easily resected and should not be extended proximally. Note Tinel's irritative phenomenon in both the ulnar and the median distribution. C. Scar following tibial nerve injury and resulting palsy. This scar might require modified Z-plasty to prevent constriction about the lower calf. D. Long scar in injury of posterior tibial nerve with resulting palsy. This scar can easily be adapted to the incision employed for nerve repair.

often difficult (fig. 183). Dissection toward and through the scar was done cautiously and slowly, in order to preserve both large and small functioning nerve branches and their accompanying vessels.

This stage of the operation was by far the most difficult and most time-consuming part. The experienced neurosurgeon knew enough to proceed cautiously. A direct primary attack on the structures in the area of greatest scarring was evidence of inexperience and poor surgical judgment. Nerves with good function or essential blood vessels were often incorporated in the scar, and normal anatomic relations were distorted by the contraction of the scar tissue. A hasty, careless approach might mean the needless severance of these important structures and, possibly, the loss of the entire extremity.

The objective was full exposure of involved nerve tissue both above and below the scar tissue until the area was visualized in which the appearance of the nerve was normal and it was in normal relation with adjacent tissue. Careful hemostasis was also essential. Satisfactory dissection could not be accomplished rapidly. In fact, many experienced surgeons commented that as their experience increased and the entire operation was performed more rapidly, the period devoted to dissection was prolonged.



FIGURE 182.—Extensive incision for mobilization and repair of ulnar nerve.

EVALUATION OF THE STATUS OF THE NERVE

As the nerve was followed from each end into the area of maximum scarring, the pathologic process gradually unfolded, and, in about half of all cases, the extent of damage was immediately apparent. If gross continuity had not been lost, careful appraisal of the status of the nerve could present many difficulties. A good idea of the condition of the nerve had usually been obtained clinically by appropriate preoperative studies, and the surgeon was able to say, before exposure, whether function had been partly or entirely lost. At this stage of the operation, he proceeded to gather further information.

The nerve, once it was properly identified, was held by moist rubber tapes. Great gentleness was essential, for a nerve is part of the nervous system, not of the musculoskeletal system, and could not be handled as if it were. If there was an obvious transection of the nerve, the proximal and distal segments were grasped by the scarred ends and freed completely from surrounding scar tissue, care being taken, as already mentioned, to preserve any important regional branches.

Electrical Stimulation

The electrical stimulator (p. 365) was essential in all peripheral nerve surgery. The bipolar electrode provided more information about lesions in

continuity than any other method. The surgeon who used it during the course of his dissection was frequently able to avoid disaster to a functioning nerve branch traversing the scar tissue which was being dissected.

Certain precautions had to be taken in the use of the electric stimulator, as follows:

1. No matter how much confidence the surgeon might have in the apparatus which he was using, it was necessary to check every negative response to stimulation by immediately testing an adjacent piece of functioning muscle, to be sure of the presence of an electric current. Contacts might work



FIGURE 183.—Scar tissue in gunshot wound of upper arm typical of missile wounds of peripheral nerves.

loose or short circuits become established in the course of repeated use and sterilization of the cord and electrodes, and without the precaution mentioned, a normally functioning nerve might be sectioned simply because it did not respond to an electrode which was temporarily dead.

2. The stimulus to evoke a response was always minimal. Otherwise, the patient was subjected to unnecessary discomfort, while contamination of the operative field could occur because of uncontrollable flexion of the joints affected by the stimulus.

3. Another reason for using a minimal stimulus was that a strong stimulus might spread to adjacent tissue and produce a false response.

Responses varied in intensity. Vague, unlocalized burning sensations were occasionally encountered in complete lesions when the distal end was stimulated. This phenomenon was considered as (1) the result of stimulation of wandering fibers which had reached the distal segments through circuitous routes through the scar tissue or (2) the result of impulses traveling along accompanying vessels. It was usually regarded as of little significance. Definite sensory responses, however, could usually be localized to definite areas of nerve distribution. They were ordinarily present on light stimu-

lation at varying distances distal to the lesion, even after the nerve had been dissected from the scar tissue. The response was more difficult to detect if the sensory stimulus in the distal segment was the result of stimulation of regenerating nerves or intact fascicles. If nerves were regenerating and if anatomic continuity at the level of the lesion was poor, the response probably represented spontaneous regeneration, and resection of the scarred area, with end-to-end nerve suture, was often advisable. If, however, the fascicles could be shown to be preserved, it was not wise to sacrifice their continuity in order to facilitate end-to-end repair of the remaining fascicles; the function of preserved nerve fibers is always better than the function of repaired fibers because of the cortical associations established in preserved fibers.

NEUROLYSIS

If preoperative investigation, gross appearance of the nerve, and electrical stimulation indicated that nerve function had been suspended only because of pressure or ischemia from involvement of the nerve in the scar, neurolysis was the procedure of choice. Extreme care was exercised in freeing the nerve from its surrounding bed of scar tissue, in order to inflict no further injury upon it. The surrounding scar tissue, particularly if it was excessive and was evidently restricting muscle function, was resected as far as possible. If gross anatomic damage was slight and the nerve trunk appeared soft, this simple procedure alone often produced gratifying, and sometimes dramatic, results. It was not uncommon, indeed, for a group of muscles which had been paralyzed for months to respond actively to voluntary stimulus after the operation. At times, this postoperative result could be anticipated from the nearly normal response to electrical stimulation at operation.

More frequently, the traumatized area of the nerve was firm, and its contour might show constriction or uniform swelling. Some surgeons recommended the injection of physiologic salt solution under the epineurium, using the ease with which the solution dissected along the nerve trunk as a diagnostic criterion. Other surgeons recommended this method as a therapeutic procedure. In such cases, however, particularly if the function of the distal segment was seriously impaired, it was not thought wise to base the fate of the nerve on either gross dissection of the nerve trunk by salt solution or on the rate of diffusion of the solution. It was usually much wiser to open the nerve sheath under direct vision and examine the fascicles. Intraneural fibrosis, particularly if it involved the perineurium of the fascicles, was often dense enough to render sections of these structures ischemic even if their anatomic continuity was undisturbed. Extensive intraneural dissection was not necessary. The procedure had to be performed with great care, in order not to interrupt the continuity of the fascicles. It was best performed under magnification by means of a loupe, with a fine-pointed knife or needle.

When the continuity of the fascicles had evidently been lost in areas of fibrosis or neuroma but possible early regeneration was suggested by a sensory response plus, perhaps, a feeble motor response on stimulation, it was often difficult for the surgeon to decide whether neurolysis alone would be sufficient or resection and suture would be the wiser course. The decision was made on the basis of clinical evaluation, gross pathologic appearance, and the results of stimulation, with due consideration of the time interval since injury. If the sensory response was satisfactory, the lack of motor response might be explained by the fact that the down-growing nerve fibers had not yet had time to reach or innervate their muscles. In such cases, particularly if the lesion was only weeks or a few months old, it was often best to wait 6 to 8 weeks, in order to evaluate the results of neurolysis alone, before resorting to end-to-end suture. If, however, the lesion was of long duration, and particularly if a fusiform neuroma was present, resection with direct suture was usually advisable without further delay.

Repeated neurolyses were done in some cases of moderate functional deficits because good function had been transmitted by electrical stimulation despite large neuromas in continuity. In such cases, if the persistent nerve dysfunction was a real disability, subsequent resection of the neuroma, in spite of its apparent function, often, surprisingly, produced no functional loss which the patient could detect, and end-to-end suture promised more.

If neurolysis was decided upon as the procedure of choice, the involved area of nerve was dissected from the scar tissue and was placed in a normal muscle plane if that was feasible. In the past, a great deal of attention had been given to techniques of protecting traumatized areas of nerves from reinvolvement in scar tissue. Tantalum foil and fibrin film were used for this purpose in many of these injuries in World War II. These methods went the way of those which had preceded them, and there is little evidence to suggest that such procedures are ever indicated.

TECHNIQUES OF REPAIR

Complete Nerve Suture

When the interruption of nerve continuity is complete, end-to-end anastomosis of the segments is always indicated. The World War II experience left no doubt that the optimum results of nerve repair could be obtained only by this method and only after proper preparation of the segments. Any other method of repair was a poor substitute or was merely one phase of the repair procedure.

The wartime experience also left no doubt that experience was the most important factor in the management of large nerve defects. Neurosurgeons who were accustomed to performing peripheral nerve surgery only very occasionally encountered nerve injuries in which end-to-end anastomosis could not be accomplished. These injuries are discussed under special headings (p. 416). Inexperienced neurosurgeons rather frequently resorted to some type of nerve

graft to overcome relatively small defects. In some instances (p. 499), end-to-end suture was done, with considerable ease, after the lapse of a few months and the acquisition of more experience by the same surgeon.

There was considerable discussion in the course of the war over the wisdom and necessity of applying orientation sutures or identification markers on the segments of the damaged nerve at debridement, to minimize their rotation and make end-to-end anastomosis of individual fascicles more likely. When the injury was of short duration and the gap was short, these markers were important. Only too frequently, however, when the nerve was inspected after the two segments had been dissected free from scar tissue, considerable rotation and displacement were observed, in spite of the markers. Furthermore, the marked disparity commonly present between the proximal and distal segments often made alinement of fascicle to fascicle a matter more of chance than of skill.

A small suture of tantalum was always placed on the epineurium of the divided segments at a measured interval from the anastomotic site, care being taken that the markers were placed as nearly as possible at the same points on the circumference of the nerve. The site could frequently be determined by the proximity of a longitudinal vessel which might have been interrupted. These markers were useful in the orientation of the nerve segments, but their greatest value was in the postoperative roentgenograms taken to determine the integrity of the suture site.

The nerve segments, after mobilization and dissection from the surrounding scar tissue, were followed proximally and distally until they appeared to lie free in normal tissue, to be of normal size and consistency, and to be surrounded by loose areolar tissue. In the dissection, great care was taken to preserve not only the muscle branches but also their blood supply, which contributes to the nutrition of the nerve trunk itself. Care was also taken during mobilization of the nerve segments to maintain, at least intermittently, the connection between the nerve tissue and the surrounding areolar tissue, so that the circulation would not be cut off. Extensive mobilization with utter disregard of the vascular supply of the nerve segment frequently resulted in a cyanotic appearance over a few centimeters of the distal mobilized segment (fig. 184). Fibrosis of the nerve segment was increased in proportion to the degree of ischemia produced by careless mobilization.

Partial Nerve Suture

In World War II, partial nerve suture was applicable to about 10 percent of all injuries in which continuity had been interrupted. Its purpose was to preserve all functioning fascicles and all which appeared to be in anatomic continuity, so that no actual or potential function would be lost and an opportunity would be established for restoration of a reasonable degree of recovery to fascicles which had been severed. Partial nerve suture required more dexterity and patience than complete nerve suture. Its proper execution de-

pended upon the complete cooperation of the patient while the stimulator was carefully applied intraneurally to the individual fascicles. Operation was performed under local anesthesia.

A lateral neuroma (fig. 185) was more easily managed than a central neuroma. The lateral lesion, with the involved fascicles, was carefully dissected free from the adjacent fascicles which were still intact. Then the fascicles which were contributing to the neuroma were stripped from the adjoining normal nerve, as much epineurium being retained as possible. The

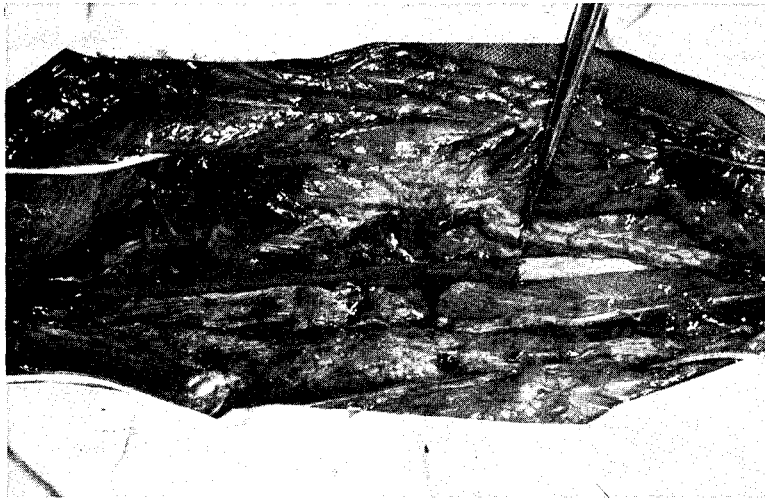

FIGURE 184.—Suture of nerve after extensive mobilization of proximal segment. Note cyanotic appearance of segment of nerve on left after extensive mobilization which damaged blood supply.

proximal segments of the involved fascicles could be dissected proximally much more easily than could the distal segments. This was partly because they were attached to the definite neuroma which the regenerating fibers had produced and partly because the distal segments of these fibers were atrophic and smaller and could be identified by their negative response to electrical stimulation.

SPECIAL TECHNIQUES

Certain procedures, many of them used in civilian practice, proved useful in overcoming defects in the continuity of the damaged nerve. These techniques are discussed in order of their importance.

Flexion-Relaxation

Before resection of the neuroma and the glioma from the ends of the severed nerve, the adjacent joints were flexed and the separated segments brought toward each other and overlapped to the extent necessary to permit

approximation of normal nerve tissue after the damaged area had been cut back. In many instances, it was immediately evident that end-to-end suture could be accomplished without undue tension.

Positions of optimum relaxation were as follows (fig. 186):

1. For injuries of the brachial plexus, the elbow was flexed and the arm adducted. The arm was held in forward flexion during nerve suture and closure of the wound. Afterward, the patient was most comfortable in a Velpeau dressing, with the hand over the unaffected shoulder. In instances of extreme tension, the position was modified by elevation of the shoulder.

2. For injuries of the neurovascular bundle or in the upper arm, the position recommended for injuries of the brachial plexus could also be used after transposition of the ulnar nerve anterior to the humeral condyle. Flexion of the elbow alone was often sufficient.

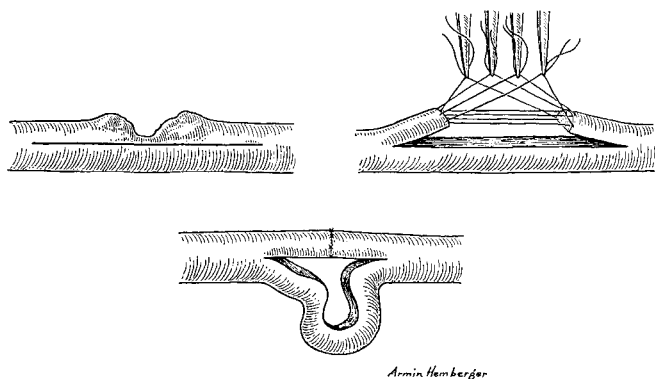

Armin Hemberger

FIGURE 185.—Procedure for repair of lateral neuroma. Note that the injured fascicles are split from the remaining normal nerve before sectioning and suture.

3. For injuries of the radial nerve near the elbow, maximum relaxation was secured by flexion and pronation of the forearm.

4. For injuries of the median and ulnar nerves after transposition, flexion of the forearm with supination was most desirable. For injuries of the median nerve in the forearm, maximum relaxation was secured by flexion of the forearm and wrist, although, when possible, flexion of the wrist was avoided because of the adverse effect of the traumatized muscles or tendons which were almost inevitably involved. For injuries of the ulnar nerve in the forearm after transposition of the nerve at the elbow, flexion of the elbow and flexion and ulnar deviation of the wrist provided the best relaxation.

5. For all injuries in the leg, flexion of the knee was required, with hyperextension of the thigh. A double hip spica was necessary to maintain this position with any degree of comfort to the patient. For injuries of the common peroneal nerve or its branches, additional relaxation was obtained by

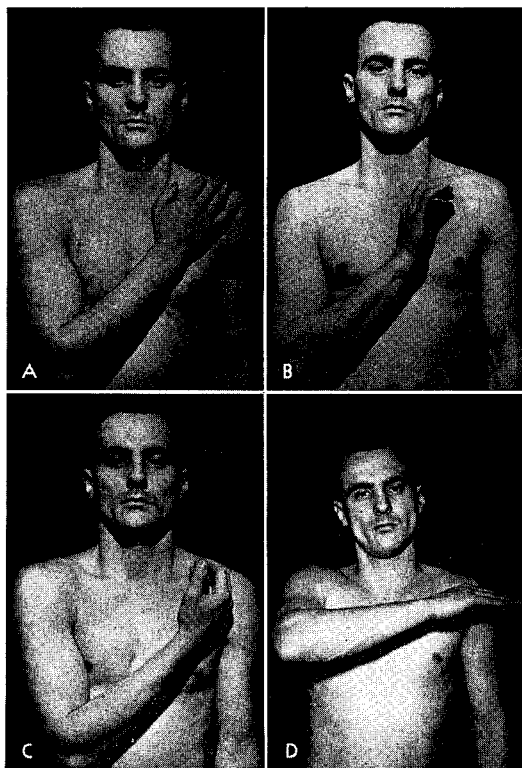

FIGURE 186.—Optimum positions for flexion-relaxation of sutured nerves. A. Nerves in upper arm, axilla, and brachial plexus. B. Radial nerve. C. Median and ulnar nerves. D. Axillary nerve and brachial plexus.

combining this position with external rotation of the leg. Sufficient abduction of the leg had to be provided to make the patient comfortable and to permit use of the bedpan.

Nerve Transposition

Nerve transposition had the objective of shortening the gap to be bridged by transposing the damaged nerve to a more superficial plane in the region of the flexed joint. To accomplish this, it was necessary to do a careful dissection of the branches of the nerve by opening the epineurium and splitting the fascicles proximally from the nerve trunk for a distance of several centimeters. Great care had to be taken, as already mentioned, not to interrupt the continuity of these fascicles, whether they were functioning, as they might be when they were dissected from the proximal segment, or were nonfunctioning, as when they were dissected from the distal segment. Nerve transposition, combined with flexion-relaxation, was usually sufficient to overcome most large defects.

Another technique, slight stretching of the nerve by traction on a neuroma or glioma, also gave good results when it was used in the management of short defects which were overcome by flexion-relaxation. It is, however, a very delicate procedure, whose abuse can produce irreparable nerve injury, and it was never used to make up distance.

Bone Shortening

Bone shortening to overcome nerve defects was limited, for all practical purposes, to injuries of the upper extremity and especially to shortening of the humerus. Under exceptional circumstances it was employed in the lower extremity, in high lesions of the sciatic nerve, when the knee joint was fixed in extension, but it was not a desirable procedure because shortening of a bone of the lower extremity severely affects body mechanics and influences both standing and walking. It was frequently applied in defects of the radial nerve, especially those associated with fractures of the humerus with poor union or nonunion. An osteotomy was performed, with resection of the deformed bone, or an oblique cut was made, with overriding of the severed bone, which reduced the total length of the humerus by at least 2 inches.

Shortening of the bone permitted adequate repair of many large defects, particularly when it was combined with flexion-relaxation of the adjacent joints. There was no appreciable loss of function in the upper extremity, in which the muscles appear able to adapt themselves readily to a limited degree of shortening. If the bone was perfectly normal, the surgeon did not usually consider resection of the humerus for a defect of the radial nerve alone; such a defect could be managed better by tendon transplants. Resection of the normal bone might be considered, however, when two or more nerves of the upper extremity were separated by gaps too great to be overcome by more conventional means. The amount of bone which could be resected without impairing the function or cosmetic appearance of the extremity varied with the size of the individual, but 2 inches was accepted as the upper limit, and it was seldom necessary to attain this degree of shortening to produce the desired result.

Two-Stage Repair (Suture of Neuroma)

Before resection of a neuroma or glioma, the surgeon estimated the gap in the nerve to be overcome later. If it immediately became evident that extensive contusion of the proximal and distal segments would make nerve suture impossible after removal of the scarred ends, another procedure had to be planned. If it was possible, after flexion-relaxation of the adjacent joints, to bring the neuroma and glioma together, a two-stage procedure was undertaken. The scarred ends were fastened together securely with metallic sutures, or, if silk was used, radiopaque markers were placed on each segment.

Gradual extension of the adjacent joints was begun after operation. When this had been accomplished, the second stage procedure was undertaken, in

the hope that sufficient lengthening of the nerve had occurred to permit good end-to-end suture of satisfactory fascicles.

This procedure was not without risk. It was always possible that nerve segments which might have been brought together by other means might become irreversibly damaged by traction or stretch palsy. Neuroma suture, however, was not without its merits. Operation was considerably facilitated if, at debridement, the contused nerve ends were available and had been brought together with a sling stitch.

Other Methods

In most cases, the results in the repair of severed nerves depended chiefly upon the length of the gap to be overcome. If it was only a centimeter or two, there was occasionally some regeneration with almost any method employed, or even in spite of the method employed. If all of the methods described, even including dissection throughout the entire extremity for maximum mobilization, had failed to overcome a gap in a nerve ready to be sutured, some one of the following procedures was occasionally attempted:

Suture à distance.—This method, which was suggested by Assaky² in 1886, merely brought the nerve ends together as closely as possible by cables of catgut running between the proximal and distal segments. In a few cases of this kind recorded in the Peripheral Nerve Registry, gaps of 2 to 4 cm. were overcome by regenerating fibers, and a certain amount of gross function was achieved. Experimental work with scaffolding of nylon, glass, and plastic threads had been successful in the laboratory, but these techniques were not employed clinically during World War II.

Tubulization.—Tubulization has been recommended with agents of almost every conceivable material, both autogenous and extraneous. No clinical experiences were reported during World War II which indicated that results were any better when this technique was used than when the gap was left unprotected.

Nerve grafts (nerve transplantation).—Nerve grafts are discussed in detail elsewhere in this volume (p. 493). In the opinion of many neurosurgeons, they have always received much more consideration than their clinical success would warrant. Good results have been achieved with them in small unmixed nerves, such as the digital and the facial nerves, but they have invariably failed to deliver sufficient functioning fibers over a sufficient distance to make them of much practical value in the repair of major nerve injuries.

Whole heterogenous or homogenous grafts, whether fresh or preserved, proved worthless. Whole autogenous grafts secured from an amputation stump and applied to the injured nerve in another limb sometimes transmitted fibers through several centimeters, but these regenerating fibers were so few and so inhibited by fibrosis that their failure was practically assured. The

² Assaky, G.: De la suture des nerfs à distance. Arch. gén. de méd. 2: 529-553, November 1886.

failure of any autogenous graft, particularly a whole graft, inserted into a nerve trunk was unquestionably due to the ischemia and fibrosis in its depth; the graft was a free transplant completely removed from its blood supply. The successes occasionally associated with cable grafting or the use of small grafts for digital or facial nerves resulted from the fact that the fascicles in these smaller structures, due to their proximity to an early blood supply, were more likely to be viable.

STEPS OF THE OPERATION

Preparation of Nerve Ends for Suture

After the nerve segments had been completely mobilized and it had been decided that end-to-end suture was feasible, scar tissue was excised from the distal and proximal stumps until the fascicles seen in cross section appeared normal and were as free as possible of surrounding fibrosis. The distal segment was usually appreciably smaller in diameter than the proximal segment, this being the result, in part, of degenerative processes in the distal segment. The glioma or scarring on the distal stump was usually much less extensive than that on the proximal stump; it extended back only as far as the extent of the contusion at the time of injury plus whatever area of fibrosis may have followed the further extension of the intraneural hemorrhage.

Scarring of the distal stump did not cause the bulbous appearance produced in the proximal stump by regenerating nerve fibers; instead, the scar tissue might be flattened or tapering or give evidence of slight swelling from the sheath cells and from fibrosis, so that the term "glioma" was fully justified. The involvement was frequently not more than a centimeter in length.

To the naked eye, discrete fascicles appeared to pout from the cut end of the nerve for a considerable time before the fibrosis had been eliminated by serial section. At this stage of the procedure, it was therefore best to use a sterile magnifying glass or loupe. On closer scrutiny, the surgeon frequently found that, if an unsurmountable gap was not to be produced, a compromise had to be made between theory and practice and that nerve ends with some degree of fibrosis had to be used. As Lyons and Woodhall³ demonstrated, the condition of the distal segment was more important than that of the proximal segment. Proximal fascicles, though not completely satisfactory, might still give off an abundance of branching axons, while a fibrous distal stump would transmit few if any. When a compromise was necessary, therefore, the sacrifice was made in favor of the distal segment, so that its fascicles might be discrete and the interfascicular spaces be as free as possible of perineurial fibrosis to receive the regenerating axons. For this reason, it was always advisable to make serial sections of the stump of the distal segment before the proximal segment was attacked.

The importance of precise, sharp cross sections in nerve repair had so

³ Lyons, William R., and Woodhall, Barnes; *Atlas of Peripheral Nerve Injuries*. Philadelphia: W. B. Saunders Co., 1949.

impressed neurosurgeons that they have introduced many ingenious devices to further this objective. Gross,⁴ for instance, devised silver miter boxes of assorted sizes to hold the nerve segments atraumatically and accurately while a razor blade is carried down through the slot. Tarlov's⁵ nerve holder grips the nerve end snugly in sponge rubber while the cross section is made.

Perhaps the commonest method employed during World War II was to steady the nerve segment with cotton pledgets on a moistened tongue depressor. The advantage of this simple method was that it was carried out quickly and that the entire nerve was well visualized while the section was made.

Serial sections were cut, about 1.5 to 2 mm. apart. Each section was left attached to the nerve by a small part of the sheath until the final section, showing a healthy cross section, had been made (fig. 187). A piece of fibrin

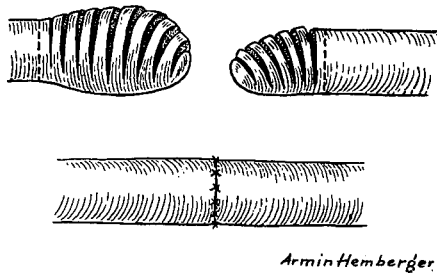

Armin Hemberger

FIGURE 187.—Classical method of end-to-end suture following resection of scarred ends by serial section.

foam or gel was placed over the freshly cut nerve end to control bleeding.

Attention was then turned to the proximal neuroma. The proximal stump of a severed nerve terminates in a bulb of regenerating neuraxes with their numerous branchings and of proliferating sheath cells and connective tissue. These regenerating nerve fibers frequently fold back upon themselves and extend proximally on both sides of the epineurium and intrinsically through the perineurial spaces to produce a typical expanding, bulblike appearance. The first few cuts might produce a rather dense, homogenous white appearance. Then there might appear large, edematous fascicles, which an inexperienced surgeon might consider suitable for approximation. They were not. When a few more serial cross sections were made, these fascicles would be seen breaking up into numerous smaller, discrete, softer fascicles unencumbered by perineurial fibrosis. At this point, the diameter of the nerve would be almost normal.

During this procedure, as well as throughout the operation, the nerve segments were handled with the greatest gentleness, by delicate iris forceps placed in the epineurium. Sponging was usually done with moist cotton.

⁴ Gross, S. W.: Device for Accurate Approximation of Peripheral Nerves. Bull. U.S. Army M. Dept. 75: 118, April 1944.

⁵ Tarlov, I. M.: Autologous Plasma Clot Suture of Nerves. J.A.M.A. 126: 741-748, November 1944.

Anastomosis

At this time, the extremity was positioned to facilitate nerve suture. If the wound was at all extensive, it was closed except in the area of the nerve suture. Some surgeons preferred to close it even before the neuroma and glioma were removed. There were two principal advantages in closure of the greater portion of the wound before nerve suture was accomplished. The first was to eliminate the difficulties which might arise in closing the wound after the necessary position of flexion had been employed. The second was that it reduced the necessity for handling the extremity between the time the anastomosis was completed and the plaster cast applied and thus reduced the opportunities for inadvertent stretching of the suture site.

Orientation sutures, previously applied, were now brought into line and the opposing surfaces of the two segments were brought together by one of several possible methods of anastomosis (fig. 188). If the distal end was very much smaller than the proximal, so that approximation would be difficult, the distal segment might be blown up by the injection of salt or procaine solution through a fine needle (fig. 189). A less satisfactory way of overcoming the discrepancy in size was to make an oblique cut across the distal segment at the last section, to increase its size.

If the nerve segments could be approximated without tension, fine epineurial anastomotic sutures were placed at once. Care was taken to place the first two sutures in diametric opposition, to prevent distortion. These sutures were left long and used to rotate the nerve as the remaining sutures were placed. If moderate tension was present, traction sutures were placed at identical points on the circumference of each segment, a few centimeters behind the site of the sutures which would pass through the epineurium alone. These two sutures were then crossed and held by an assistant with a hemostat over the point of tension where the surfaces to be sutured came together without tension. They were removed after the anastomosis had been accomplished.

Livingston and his associates⁶ proposed still another method of anastomosis. At the same circumferential point in each segment, a small lip of the sheath is left to extend distally. Small, matched mosquito clamps are placed on these tabs adjacent to the cut surface of the nerve and are rotated 180°, so that they can be held together and thus bring the surfaces to be approximated into apposition. The last two sutures are left long. The tabs are then resected and their points of epineurial attachment closed.

When stay or sling sutures were applied (fig. 190), it was best to use 0.005 tantalum. The sutures were placed in the proper plane, about 1 to 1.5 cm. from the cut surfaces of the nerve, and were used to draw the nerve ends into approximation. The ends of the suture were held at their point of emergence from the nerve by two hemostats or were tied if correct tension could be exerted and if their presence did not interfere with the approximation stitches to be placed in the epineurium later.

⁶ Livingston, K. E., Livingston, W. K., and Davis, E. W.: A Technique of Nerve Suture. *J. Neurosurg.* 3: 270-271, May 1946.

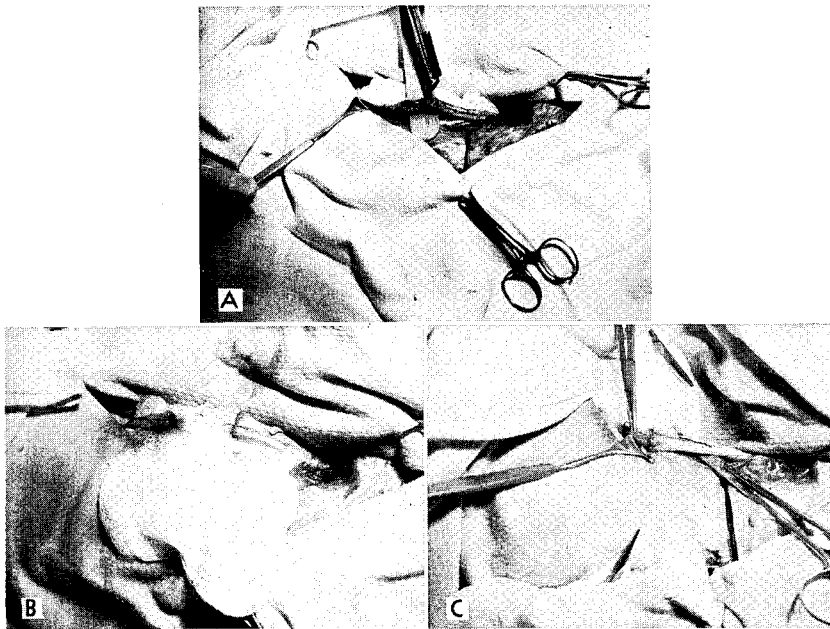

FIGURE 188.—Customary method of resecting scarred portion of nerve. A. Orientation sutures in place. B. Fine tantalum epineurial sutures in place for demonstration purposes. They have not yet been tied. C. Fine epineurial approximation sutures used to complete anastomosis.

There was no doubt that good results were accomplished by the use of the transfixing or sling suture technique, but many surgeons thought its employment superfluous, and the introduction of these sutures necessarily meant additional trauma to the transected fascicles. If, however, early mobilization of the adjacent joints was particularly desirable and it was thought that the strain on the suture site could not be borne by the delicate approximation sutures alone, the transfixing sutures had their place.

Some surgeons preferred to secure the tension effect of transfixing stay sutures by using mattress-type sutures for the epineurium. Two were placed in diametrically opposite locations, each passing through a small bite of the epineurium in both the proximal and the distal segments. A more satisfactory type of epineurial tension suture was described by Learmonth and Wallace,⁷ who placed several small interlocking loops in the epineurium on each side of the suture site. The delicate approximation sutures in the epineurium, which were placed with a fine atraumatic needle, were so spaced as to bring the epineurium together throughout its entire circumference and prevent the exposure of aberrant fibers.

Apposition of the opposing surfaces of the cut nerve by suture practically always controlled bleeding. If it did not, fibrin or Gelfoam soaked in throm-

⁷ Learmonth, J. R., and Wallace, A. B.: Certain Plastic Problems in the Surgery of Peripheral Nerves. *Surg. Gynec. & Obst.* 76: 106-109, January 1943.

bin was applied. Care was taken to see that all foreign material had been removed before the nerve suture was completed.

Protection of Site of Anastomosis

Transplantation.—Some surgeons, after the nerve had been sutured, thought it beneficial to transplant the site of anastomosis to a fresh muscle plane free from scar tissue. The theory was good, but the plan was not prac-

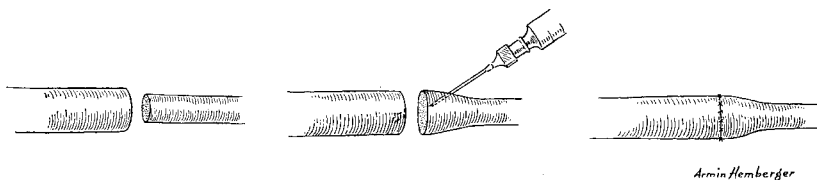

FIGURE 189.—Method of enlarging distal segment to facilitate anastomosis. Novocain or saline solution may be used.

tical. In extensive combat-incurred injuries, there was no such muscle plane in the vicinity of the injured nerve. This practice also had its disadvantages, in that it required dangerous lengthening of the nerve. It was frequently possible, however, to transplant the suture site superficially to an adjacent subcutaneous area in which it would be surrounded by viable fat and run little risk of further fibrous fixation.

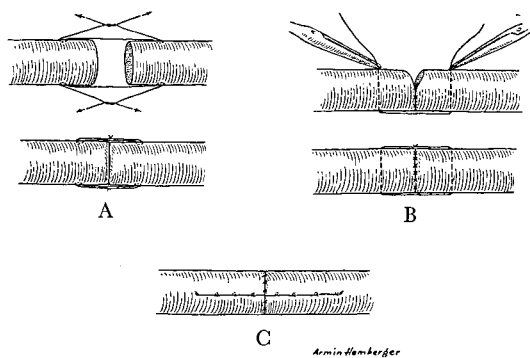

FIGURE 190.—Suture techniques. A. Epineurial sling sutures, diametrically opposed, which do not pierce fascicles. B. Through-and-through suture. Here the suture is passed directly through both proximal and distal segments. The nerve is held in approximation by means of hemostats on the stay suture at its level of emergence from the nerve. The suture is tied after approximation stitches have been placed. C. Interlocking epineurial stay suture recommended by Learmonth and Wallace. Although this suture requires a little more time, its holding power is greater, and the fascicles are not pierced by it.

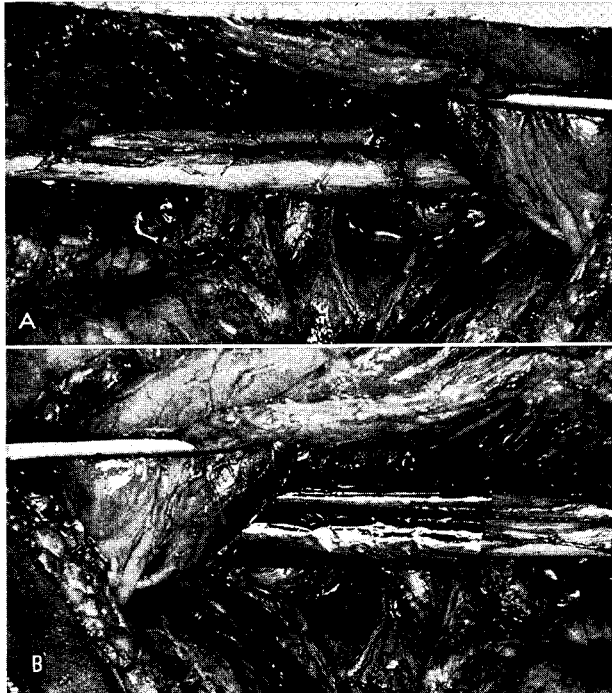

FIGURE 191.—Suture techniques. A. Suture of both components of sciatic nerve. B. Protection of suture line with annealed tantalum foil.

Tantalum foil.—Early in World War II, when tantalum, which is relatively inert in tissues, began to be produced in thin foil, it was thought that it might be useful as a protective wrapping for injured nerves (fig. 191). At first, it was coiled as neatly as possible about the site of anastomosis and held by restraining ligatures. The idea was that fibrous tissues would thus be barred from invading the suture site and fixing it to adjacent tissues. The further result, it was thought, was that the tension would be dispersed throughout the entire length of the nerve when the extremity was gradually permitted to extend.

Some of these results were obtained, but there were also a number of undesirable results. The distal ligature used to hold the foil against the nerve was found to act as a constricting band which inhibited the downgrowth of neuraxes into the distal segment and prevented it from attaining the diameter of the remainder of the nerve. When the operative site was reexplored and the constricting band was removed, the tissue enclosed within the foil presented as a smooth, glistening layer (fig. 192), which prevented adhesions between the nerve and the surrounding tissue. The foil, however, was often found broken and cracked, particularly when it had been placed near a joint. To overcome this difficulty, slightly heavier foil (0.0005 inch) was annealed into coils or tubes which were cut to the size of the nerve and which, when

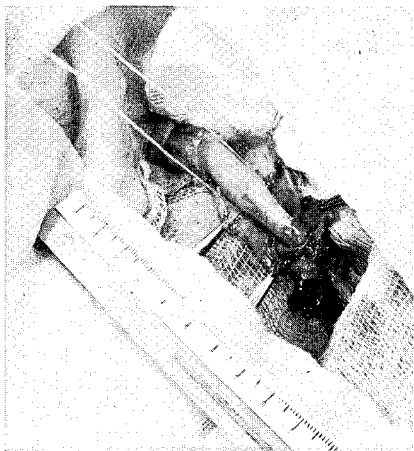

FIGURE 192.—Appearance of nerve suture site after removal of tantalum foil. Note glistening appearance with surrounding membrane, but note also scar limitation at each end.

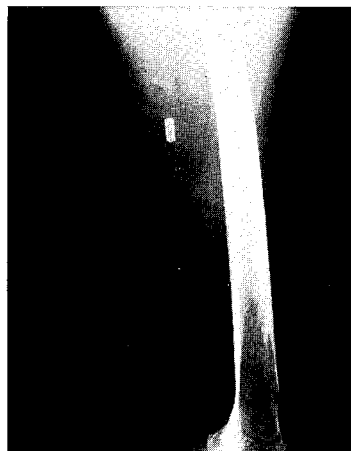

FIGURE 193.—Small cuff of tantalum foil illustrating size adequate to surround suture site only.

applied, it was thought would remain snugly against the epineurium by their own spring action. When foil thus prepared was not placed in the region of a joint and was not sufficiently overlapped to produce a constricting membrane, it seemed to fulfill the desired purposes. Surgeons who used this method usually employed rather short cuffs, about 1 to 1.5 cm. in length, just long enough to protect only the suture site (fig. 193).

Tantalum was misused by many surgeons, and trauma to the enclosed nerve was often evident upon reexploration. As a result, it was rather generally condemned. Its use in selected cases to protect the anastomotic site had obvious advantages, but the disadvantages attendant upon its employment, and the harm attendant upon its misuse, warranted prohibition of its use routinely. It is entirely possible that the disadvantages associated with the use of any material to be wrapped about a repaired nerve exceed the advantages of its use even in occasional, carefully selected cases.

Selection of Suture Material

Almost every known suture material was used at one time or another for the repair of peripheral nerves, including catgut, linen, silk, nylon, cotton, stainless steel, human hair, and tantalum. All resulted in some degree of success. Before World War II, fine silk was most generally used, but experiences during the war indicated the definite advantages of tantalum.

Tantalum, like stainless steel, is more inert and therefore less irritating to the tissues than silk or other organic suture materials. It is a more uniform element than steel. It is more malleable, which makes it easier to

handle and to apply to the fine atraumatic needles into which it may be swaged. A tantalum thread of the same diameter as silk has equal tensile strength on straight pull, but, after both are sterilized, tantalum has 40 per cent more strength than silk on knot pull. The radiopacity of tantalum also proved an enormous advantage. These metallic sutures (fig. 194) made it possible to make serial roentgenologic studies of the integrity of the suture line.

The more inert the material used for sutures, generally speaking, the less the surrounding tissue reaction and the less the ultimate fibrosis. On the other hand, with few exceptions, it is doubtful that the material used for sutures was as important as its size.

OTHER METHODS OF ANASTOMOSIS

Removable Suture Technique

The pullout suture method devised by Bunnell for repair of tendons was adapted by Potter⁸ for repair of selected cases of peripheral nerve injuries. This technique is carried out as follows: A wire loop brought through the skin on one needle is placed through another wire loop formed by passing the wire twice through the epineurium of each segment. The wire is then brought through the skin and tied over a button. A similar procedure is carried out with another wire suture, the loop in the epineurium being diametrically opposite the first loop and the pull being on the opposite segment. After a period of 2 to 3 weeks, each wire is cut and withdrawn. The advantage of this method is that the anastomosis is left uninfluenced by any foreign material. The need for it, however, is scarcely sufficient to warrant the technical difficulties. Occasional good results were reported, but the instances in which the technique was feasible were not numerous.

Tube Technique

Weiss⁹ reported excellent experimental results in the repair of severed nerves with segments of arteries and veins and with preformed tubes of collagen or tantalum. The precise technique and special instruments required make this method impractical for combat-incurred injuries. Furthermore, all nerves of the human subject are apparently under some degree of tension, and this is not a method applicable to injuries in which any degree of tension is present.

Plasma Clot Anastomosis

The sutureless method of anastomosis proposed by Young and Medawar¹⁰ involved the use of a coagulated plasma cuff produced by adding chick embryo

⁸ Potter, S. E.: A Removable Suture Method of Nerve Repair. *J. Neurosurg.* 3: 354-357, July 1946.

⁹ Weiss, Paul: Experiments on Nerve Repair. *Tr. Am. Neurol. A.*, pp. 42-51, 1943.

¹⁰ Young, J. Z., and Medawar, P. B.: Fibrin Suture of Peripheral Nerves. Measurement of the Rate of Regeneration. *Lancet* 2: 126-128, 3 Aug. 1940.



FIGURE 194.—Postoperative roentgenogram demonstrating presence of tantalum sutures. Note sutures in infraclavicular region. These are well clustered and denote integrity of brachial plexus repair.

tissue to concentrated blood plasma and allowing a coagulum to form about the nerve ends as they were held in apposition. This method has the disadvantage of all sutureless methods; namely, its limited tensile strength. Tarlov¹¹ modified the technique by holding the nerve ends together by a single sling suture of tantalum wire. He also surrounded the anastomotic site with a rubber mold into which the patient's chilled blood plasma was poured. The improvement in results when this method was used did not compensate for the technical difficulties attendant on it.

Another sutureless method, proposed by Singer,¹² utilized fibrin film, which is a byproduct of the preparation of plasma and serum albumin from whole blood. Two pieces of film were cut into squares large enough to surround the nerve. They were then soaked in thrombin, and one side of each square was dipped into fibrinogen. The treated sides were placed about the suture site opposite each other. Coagulum formed immediately, and the pieces of film adhered to the nerve and to each other. The technique of this method was simple, but sterilization of the film frequently required sufficient denaturation to produce a considerable foreign-body reaction, and the resulting fibrosis thus undid any possible advantage of this method as compared with direct suture methods.

Nerve Grafting

As already mentioned, the technique of nerve grafting is described in detail elsewhere in this volume (p. 493).

¹¹ Tarlov, I. M.: Plasma Clot Suture of Nerves. *J. Neurosurg.* 1: 359, September 1944.

¹² Singer, M.: The Combined Use of Fibrin Film and Clot in End-to-End Union of Nerves. *J. Neurosurg.* 2: 102-115, March 1945.

REGIONAL INJURIES

The Brachial Plexus

Injuries of the brachial plexus by penetrating missiles seldom involved the entire structure, but the extent of the paralysis often greatly exceeded what would have been expected from the fibers which were sectioned. The explanation was undoubtedly the characteristically dense fibrosis which follows hemorrhage in this region. In one neurosurgical center, 5 percent of all nerve sutures performed in the course of World War II were for injuries of this plexus.

The anatomy of the important group of nerves constituting the brachial plexus usually had to be remastered by military neurosurgeons before they attempted the repair of nerve injuries in this region. With this knowledge, it was usually possible to locate the site of the lesion clinically, and the location of the scar and the course of the missile were of further assistance in localization when the injury was direct. In the indirect or traction type of injury, the roots were usually involved, and, if the injury was severe, there was some evidence of cord damage. Even when there was evidence of an avulsion type of injury, it was the policy to explore the plexus and perform a neurolysis, at least.

Operation was performed as follows:

With the patient lying supine, the neck, the shoulder, and the entire upper extremity on the affected side were prepared and draped. A horizontal, supraclavicular incision was made, transecting the platysma and the clavicular portion of the sternocleidomastoid muscle. This incision usually provided adequate exposure of the upper portion of the brachial plexus. For exposure of the divisions and cord, the outer angle of the incision was extended downward between the pectoralis major and deltoid muscles. If the lesion was low lying, or if lower exposure was desired to permit more adequate identification, the tendon of the pectoralis major was sectioned close to its insertion, the muscle was reflected, and the incision was continued posteriorly into the axilla as far as the neurovascular bundle. It should be stressed that the incision for exposure of the lower portion of the brachial plexus and the extension to disclose the axillary contents followed the course of the cephalic vein, curving posteromedially over the neurovascular bundle only after it had crossed the insertion of the pectoralis major bundle.

Other incisions proposed for exposure of the brachial plexus, such as those curving medially along the lower border of the pectoralis major muscle, provided adequate exposure of the axilla when the flap was reflected, but upward extensions, which were frequently necessary, were awkward. The transverse incision of the dome of the axilla proposed by Seletz¹³ was difficult to close, particularly after positioning to overcome nerve defects in this

¹³ Seletz, E.: Peripheral Nerve Surgery: Review of Incisions for Operative Exposure. Preliminary Report. *J. Neurosurg.* 3: 135-147, March 1946.

region. It was sometimes possible to expose the infraclavicular portion of the plexus merely by retraction of the pectoralis major, thus avoiding the removal of its insertion and its reflexion.

Whenever a nerve anastomosis was required, the exposure was always extended to permit adequate mobilization and identification of the involved segments. The pectoralis minor was then separated from the coracoid process and the lower plexus visualized. If the lesion was retroclavicular, the clavicle was transected. Experience showed that a subperiosteal resection of about 2 inches of clavicle improved the exposure without complicating the post-operative course or impairing the cosmetic results.

As in repair of the more peripheral nerves, it was always necessary, in lesions of the brachial plexus, to isolate its components both above and below the area of involvement. By careful neurolysis, identification of the various components of the plexus was gradually established. The electric stimulator was used repeatedly.

If the injury was restricted, neurolysis was all that was necessary, though the surgeon could not be content to leave the plexus matted together by scar tissue into a solid structure.

When the supraclavicular approach was used, the upper nerve trunk, which lies most superficially and was most often involved in closed traction or avulsion injuries, was most readily identified. Its roots of origin are quite clear as it emerges from behind the scalenus anticus and lies on the scalenus medius. The trunk itself, which is quite short, breaks up into three branches, the supraclavicular nerve and the anterior and posterior divisions.

The middle trunk was readily identified as an extension of the seventh root beneath the upper trunk. The lower trunk was more difficult to expose in its proximal portion, but injuries in this area were rather infrequent; because of the proximity of the subclavian artery, deaths from hemorrhage often occurred.

Lesions of the divisions and cords of the brachial plexus were so intimately associated with injuries of the subclavian and axillary arteries that aneurysms, which might not have been recognized before operation, were sometimes encountered. When they were, it was always necessary to isolate the vessel proximal to the lesion to be ready to control hemorrhage which might occur.

The dissection of the normal plexus, with the branching of its trunks into divisions and fusion of the divisions into cords, is a very difficult task. It is therefore easy to understand the tedious and exacting dissection required when the entire structure was embedded in scar tissue. Constant use of the stimulator, with isolation of functioning branches, was essential. Portions of the plexus which had been divided and separated by small gaps in scar tissue had to be dissected free and the proper associations established between their proximal and distal segments. After these ends had been sectioned until satisfactory fascicles were seen, they could often be brought together simply by

raising the shoulder. If a portion of the clavicle had been removed, further relaxation could be produced by bringing the shoulder forward and flexing the arm.

After satisfactory reconstruction had been accomplished, the muscle tendons were reattached to their insertions, and the wound was closed. The arm was put up in a Velpeau plaster bandage applied sufficiently snugly to prevent traction.

The Axillary Nerve

Surgery upon the axillary nerve has always given notoriously poor results, primarily because of the difficulty in compensating for nerve defects by positioning of the arm.

The upper portion of the nerve was exposed through an anterior incision similar to that employed for exposing the lower portion of the brachial plexus. The incision was carried along the course of the cephalic vein, thus separating the deltoid from the pectoralis major muscle. The pectoralis muscle was divided at the insertion, the deep pectoral fascia was opened, and the overlying median nerve and axillary artery were retracted medially, disclosing the radial nerve, which was followed upward to the origin of the axillary nerve at the lower end of the posterior cord. Since the upper branch of the triceps frequently comes off quite high, it was sometimes confused with the axillary nerve, but its identity was readily established by electric stimulation.

The nerve could be followed well into the mid axilla by the exposure described. Further exposure could be obtained, if necessary, through a dorsal incision made along the posterior border of the deltoid muscle; when the muscle was retracted upward, the nerve was observed coming through the quadrilateral space to supply its undersurface.

Repair of the proximal third of the axillary nerve was accomplished fairly easily, and results were often good; but repair of the distal portion was extremely difficult, particularly if the gap was of any size, and results were, in general, not satisfactory.

The Musculocutaneous Nerve

In contrast to the axillary nerve, which is the deepest and most inaccessible terminal branch of the brachial plexus, the musculocutaneous nerve is the most superficial and most readily accessible of its terminations. For this reason, and because of the gross function which it distributes, chiefly flexion of the forearm, the results of repair of the musculocutaneous nerve were frequently gratifying.

Since this nerve arises from the outer cord of the brachial plexus along with the lateral head of the median nerve, varying portions of the lateral head of the median nerve may accompany the musculocutaneous nerve within its sheath. The lateral head, in fact, may sometimes be entirely absent from its usual location, the fibers joining the median nerve in the region of the

antecubital space. For this reason, paralysis which follows section of the musculocutaneous nerve was sometimes far greater than would be expected from this injury.

The approach to the musculocutaneous nerve, particularly in its upper portion, was the same as the anterior approach to the axillary nerve. The musculocutaneous nerve passes between the two heads of the coracobrachialis muscle and lies upon it and upon the undersurface of the biceps, sending branches to both of them. It then pierces the fascia between the brachialis and the biceps to extend its sensory course to the lateral aspect of the forearm. Injuries to the midportion of the upper arm may thus divide branches of the nerve as well as the parent nerve, and careful search should be made for them in the repair, since the branches to the biceps usually represent the greatest function of the nerve. Because of the excellent compensatory function of the brachioradialis nerve in producing flexion of the forearm, early, adequate repair of the musculocutaneous nerve was sometimes considered unnecessary, and results of surgery were jeopardized by the delay.

Exposure for the lower portion of the musculocutaneous nerve was the same as exposure of the neurovascular bundle as a whole, with retraction of the anterior skin flap.

The Median Nerve in the Arm

From the point of view of function, the median nerve is the most important single peripheral nerve in the body. Injury to it usually involves the ulnar nerve and the medial cutaneous nerve also, since all three nerves lie in rather close association within the neurovascular bundle in the upper arm. The musculocutaneous nerve and the radial nerve in the upper third of the arm and in the axilla are also frequently involved in the same injury because of their continued close association in this area. At the elbow, although the three main trunks have become more evenly dispersed circumferentially about the arm, it was still not at all unusual for a penetrating injury to affect two or more of these structures simultaneously. As a rule, injuries to the neurovascular bundle were very grave, particularly if an artery were damaged. If the collateral circulation was not promptly established, the traumatic lesion was often complicated by a severe ischemic paralysis of the forearm, the end result being a Volkmann's type of contracture which would militate against the success of any surgical repair.

The incision was made with the patient positioned as for exploration of a plexus injury, with the arm abducted and externally rotated. In the axillary area, the nerves are in such proximity to each other that their exposure is similar to that for injuries of the lower plexus. The pectoralis major tendon was reflected and the incision was extended downward over the course of the neurovascular bundle. Sufficient exposure was thus provided to identify the damaged nerves and follow them upward through scar tissue to their point of section.

Injuries above the nerve heads.—When the injury of the median nerve was at or above the junction of its two heads, alinement of the proper funiculi with each other was facilitated, and the correct radicular constituents were more likely to traverse their original fasciculi. This possibility was somewhat overstressed in the older literature. It was often an impractical objective, particularly in some old, complete lesions. It was, however, a possibility in the median and ulnar nerves, and every effort was made to promote as precise an alinement of corresponding fascicles as could be obtained in them, since these nerves are not only important mixed nerves but their ultimate function is extremely intricate.

Lesions at this level therefore required the exposure of the terminations of the brachial plexus and of the nerves in the forearm. Due care was taken to distinguish the median nerve from the ulnar and the musculocutaneous nerves, as well as to distinguish the ulnar nerve from the medial brachial cutaneous and the medial antebrachial cutaneous nerves. These nerves, which are purely sensory terminations of the medial cord, were frequently all involved in the same injury which had affected other structures in this region, particularly the ulnar nerve. The appropriate proximal stumps were often difficult to recognize because of edema and distortion, especially if they arose from the same cord. With correct knowledge of their distribution, however, they could be recognized by the sensory distribution perceived by the patient upon electric stimulation.

Injuries in the upper third.—If the defect was in the axilla or the upper third of the arm and was small, it could be overcome by flexion of the elbow and adduction of the arm alone. If it was more extensive, and particularly if it was in the ulnar nerve, it might be necessary to extend the incision along the ulnar nerve into the forearm, mobilizing the nerve sufficiently to transpose it anterior to the medial condyle of the humerus, in order to obtain the additional benefits received by flexing the elbow.

Injuries in the middle third.—There are no branches of the median nerve in the middle third of the arm, which greatly facilitated dissection in wounds in this area involving the neurovascular bundle. Great care had to be taken in dissecting the injured nerves from the surface of an intact brachial artery. Irreparable damage to the forearm from ischemia could follow accidental section of this vessel, and, when the accident happened, an immediate attempt was made to restore its continuity. If an aneurysm were present, no apprehension usually had to be felt concerning the vascular supply because a rich collateral circulation was probably already present.

It was frequently possible in the middle third of the arm to transpose a sutured nerve into a muscle plane along the coracobrachialis or the biceps, or, more superficially, into the subcutaneous area. Repair of lesions of the ulnar nerve at this level, even if the gaps were slight, was best supplemented by transposition of the nerve anterior to the medial epicondyle for relief of tension.

Injuries in the lower third.—Lesions of the median and ulnar nerves in the lower third of the upper arm were less likely to be associated with each other, and incisions for their exposure varied. When both nerves were involved, both could be exposed by following the incision along the course of the ulnar nerve, carrying it to the midpoint of the forearm, and elevating a flap of skin at the elbow. When this flap was retracted laterally, the median nerve was exposed.

Combined or separate lesions of the median or ulnar nerve in the lower third of the upper arm at any point proximal to the origin of the first muscle branches frequently presented the problem, particularly if the gap was large, of adequate mobilization of the distal segment before repair could be undertaken. This was because of the short length and the course of the muscle branches.

If this difficulty arose in the median nerve, it was solved as follows: The bicipital fascia, which was opened during exposure of the nerve, was not closed after suture. The nerve was thus allowed to assume a more superficial location, which appreciably shortened its course. Next, the muscle branches from the median nerve were carefully mobilized. Obviously, after these nerves had been dissected back as far as possible into their muscles, whatever restriction upon their free mobilization still existed was the result of the shortness of the branches themselves rather than of the parent nerve. It was therefore not necessary to transpose the median nerve superficial to the pronator, since the trunk itself was not under tension. The restriction upon mobilization of the distal segment was apparently due to the pull of the branches in the order of their respective appearance. If further mobilization was essential, one or more of these branches therefore had to be sacrificed.

Fortunately, the first two of these branches supply the pronator. Weakness of this muscle is not a serious handicap and was regarded as worthwhile if the sacrifice would permit the regeneration of further strength and sensation to the hand.

Repair of the ulnar nerve by careful dissection of the branches to the flexor carpi ulnaris, both along the nerve trunk and, in selected cases, into the muscle itself, permitted the transposition of this nerve medially to a point at which most defects in the area could be overcome when the elbow was flexed. The great advantage of overcoming large nerve gaps by flexion at the elbow introduced two considerations. First, when large defects were overcome in this manner, the involved structures were seen to be under considerable tension when any extension at all was attempted. In these cases, the wisest plan was to persuade the patient never to attempt complete extension and by all means to avoid forced extension; if there is sensation in the hand and if there is useful associated motor function, it is always much more satisfactory to have an arm in considerable flexion. The second consideration was that lesions of these nerves anywhere in the extremity were also bene-

fited by flexion of the elbow if dissection had been adequate in the forearm, in which the median and ulnar nerves were more likely to be injured independently.

The Median Nerve in the Forearm

Damage to the median nerve and its branches in the forearm was likely to be disastrous because of its effect on the function of the fingers and hand. This is a region in which knowledge of the detailed anatomy was essential to the neurosurgeon confronted with such a situation. The results were often disheartening, but it was nonetheless worthwhile to make every endeavor to identify the branches and to carry out repair.

To expose the median nerve in the forearm, an incision was made along the neurovascular bundle in the upper arm and brought down to the medial portion of the flexion crease in the elbow. This crease was followed laterally to just beyond its midpoint. Here, a right-angled incision was made and was carried down the mid forearm. This type of incision prevented the unfortunate effects of any straight pull of a scar across the flexion crease. The median nerve was isolated above and below the pronator teres, the more distal exposure being accomplished by retraction of the flexor carpi radialis and the flexor digitorum sublimis after separation of its radial attachment. If the lesion was beneath the superficial head of the pronator teres, it was usually necessary to reflect this muscle from its insertion into the radius to promote adequate exposure.

Injuries of the upper forearm.—Lesions of the median nerve distal to the lower border of the pronator teres have the same neurologic effects as lesions of the median nerve at the wrist, and repair of even large gaps in this region was possible without loss of motor function. In such cases, the tendinous arch of the flexor sublimis was opened, and, by retraction of the superficial head of the pronator, any motor branches emerging from the main trunk could be carefully separated by opening the epineurium and carrying the dissection upward. If the median nerve was transected above the point at which these branches come off, sutures were placed with due recollection of the fact that the motor supply to the muscles in the forearm comes from the medial side of the nerve. If this fact were not borne in mind, confusion, rotation, and interfunicular crossings were likely to result.

The phenomenon of axon splitting frequently overcame the surgeon's best efforts to rearrange funicular topography, even in acute lesions, before atrophy had occurred. When sensation first returned to an area, touch or tactile stimulation might be localized not only in the area touched but in one or more other areas, while, at times, sensation was referred entirely to other areas instead of to the area stimulated. With the passage of time, this confusion tended to become less marked, and the patient, as the result of reeducation, experience, or both, came to find that distortion of sensation seemed much less important than it had seemed originally.

The proximal segment was drawn proximally from beneath the pronator, which was then retracted downward and medially, and the motor branches were farther dissected until they were found to compose a separate bundle. The dissection could easily be carried upward as far as necessary to permit transposition of the median nerve superficial to the pronator. When the nerve was in this position and there was sufficient flexion of the elbow, all but the most extensive gaps could be overcome. If loss of function to the deep flexors was apparent upon faradic stimulation, an additional search was made for the volar interosseous branch, which was repaired when possible.

Injuries of the mid forearm.—It was not unusual in wounds of the median nerve of the mid forearm to find a great deal of scar tissue and distortion. In such cases, the nerve was picked up at the wrist, where it lies just medial to the tendon of the flexor carpi radialis, and was followed proximally through the scar tissue to its point of termination. It was easily identified at the antecubital fossa, where it passes along the medial side of the biceps tendon along with the brachial artery.

Injuries at the wrist.—At the wrist, injuries of the median nerve were frequently associated with transection of tendons and sometimes of primary vessels. In such cases, it was often advisable to repair both tendons and nerves at the same operation.

The ends of the nerves were first isolated and were protected with packs of moist cotton. The lacerated tendons were then identified, and, if there was no considerable loss of substance, were sutured together. When loss of substance was so great that direct suture was not practical, it was often possible to suture the distal segment into a proximal tendon which had the same physiologic function.

The palmar cutaneous branch is the single branch of the median nerve proximal to the wrist which is of any importance. It leaves the median nerve before it passes under the annular ligaments and usually travels with the vessel into the palm. Since this branch of the median nerve supplies sensation to the palm and thenar eminence, time and effort to repair it were warranted. If the median nerve had been severed at or near its origin, it was sought for and incorporated into the repair whenever this was practical. Small gaps could be overcome by flexion of the wrist alone. This nerve, however, is of such importance to the hand that the surgeon did not hesitate to take radical measures to restore it.

The best technique was to dissect it throughout the forearm, dissect the proximal motor branches from the sheath under the pronator teres, and transplant the nerve superficially, in order to achieve adequate suture repair without tension. The disability associated with extreme flexion of the wrist, particularly when tendons are involved, often justified overcoming the gap principally from the relaxation accomplished by flexion of the elbow alone. Physical therapy was then employed to prevent adhesions, with resulting contractures, about the sites of tendon repair.

Injuries in the hand.—Injuries to the median nerve or its branches in the palm are quite common in peacetime, when they are usually the result of such accidents as falling on broken glass or lacerations from porcelain handles of faucets. In military practice, these wounds were of two types. The first type resulted from the accidental or purposeful discharge of a rifle or pistol. The second type was the combat-incurred injury, which was part of an extensive injury from shell fragments or the explosion of boobytraps. The true combat-incurred injury involved reconstruction of the whole hand and was usually treated in a hand center equipped and staffed for this work.

When the nerve was the principal tissue damaged, it was essential that it be thoroughly exposed and all its branches identified, so that proper anastomoses could be performed. The skin was open by a Z-shaped incision across the flexion crease of the wrist. The incision was extended along the palm, along one of the flexion creases which turns about the thenar eminence of the head of the first metacarpal. When the palmar fascia was opened, the median nerve was exposed as it emerges from under the annular ligament and lies lateral to the flexor tendons. It was frequently possible to produce enough relaxation in the nerve to bring a suitable stump, 2 to 3 cm. long, down into the palm and suture the distal segments of the primary branches of the nerves in the hand into it.

Lesions in the digital nerves could be repaired by direct suture if the gap was not too great and by nerve graft if it was. The most important branches from this standpoint were those to the thumb and index finger. The recurrent painful neuromas which were discouraging sequelae to some of these procedures in the past were often successfully controlled by sympathectomy.

Functional results.—Functional results of repair of the median nerve in the upper arm or forearm were frequently good as far as return of gross motor power was concerned. On the other hand, in spite of every effort at correct funicular arrangement—at the best, this was crude in combat-incurred injuries—and with the return of gross sensation, the intricate function necessary to form many of the simple acts performed with the thumb and index finger was lacking. One patient whose median nerve in the distal forearm was repaired under highly favorable circumstances was reexamined 4 years after operation. Thenar atrophy, which is often persistent, had completely disappeared, and tactile sensation was good throughout, even to the point of reasonable two-point discrimination. The patient noticed no handicap in his ability to play the piano, but he still could not wind his watch with the affected hand. If the relatively extensive representation of the thumb on the motor cerebral cortex is recalled, it is easy to understand that it is completely unreasonable to compare the manifestations of regeneration in such a specialized nerve as the median with those of the radial nerve, whose function is gross and almost completely that of extension.

The Ulnar Nerve

The ulnar nerve was the most frequently injured of all the peripheral nerves in World War II. Its subcutaneous location and its proximity to bone made it particularly susceptible to trauma in injuries about the elbow.

The ulnar nerve was exposed in the forearm by an incision which roughly followed the course of the nerve from the distal third of the upper arm downward and posterior to the medial condyle of the humerus. This incision, which was curved slightly forward, was continued along the antero-medial aspect of the forearm just medial to the flexor carpi ulnaris muscle and tendon in the distal half of the forearm and wrist.

Injuries at the elbow.—If the nerve lay in its normal position in the medial aspect of the elbow, simple transposition out of this location to a subcutaneous position anterior to the condyle was often all that was necessary to relieve its fixation in callus, swelling, or a large fusiform neuroma. This procedure was sometimes combined with external and internal neurolysis, the sheath being left open.

In injuries at the elbow with complete section of the ulnar nerve, the proximal segment was identified as it pierced the intermuscular septum, and the distal segment could be identified just beneath the head of the flexor carpi ulnaris muscle. When the lesion was located just proximal to the origin of the muscle branches, it was frequently impossible to achieve sufficient mobility of the distal segment to overcome a large gap, though moderate transposition of the nerve anteriorly and flexion-relaxation of the elbow often overcame a defect of several centimeters. If necessary, the upper branches of the flexor carpi ulnaris muscle were sacrificed; this procedure considerably increased the medial transposition of the nerve and, additionally, shortened its course. By sacrificing all of the branches, gaps up to 12 to 14 cm. were successfully repaired. Such a procedure, however, was not lightly undertaken. Much of the strength of the hand passes through the ulnar branches of the flexor digitorum profundus, and return of gross function to this muscle usually occurred after nerve suture. On the other hand, return of function to the intrinsic muscles of the hand was more uncommon, particularly if the nerve injury had been present long enough for extensive atrophy to occur.

Injuries in the upper forearm.—Lesions of the ulnar nerve distal to the branches of the flexor digitorum profundus were easily repaired, but dissection of the nerve was necessary from the level at which it pierces the muscular septum in the upper arm to the wrist. By dissection of the branches of the flexor carpi ulnaris and the flexor digitorum profundus, it was possible to reroute the nerve anterior to the humeral condyle, as well as medially, which accomplished extensive shortening of its course. The muscle branches had to be separated from the parent nerve with great care; the epineurial sheath was opened by delicate iris scissors or the point of a knife blade. Such extensive dissections were not always successful, chiefly, it was

thought, because of anoxia caused by depletion of the blood supply of the nerve in the course of the dissection and mobilization. This risk always had to be borne in mind in operations on the ulnar nerve in this location, in which it was usually necessary to separate the proximal segment, at least, from its intimate connection with the ulnar artery.

Injuries in the lower forearm and wrist.—Management of lesions of the ulnar nerve in the distal portion of the forearm and at the wrist required preoperative knowledge of sensation to the dorsum of the ulnar aspect of the hand and the fourth and fifth fingers. If sensation was absent, it was necessary to identify the dorsocutaneous branch of the nerve. If the lesion was proximal to the origin of this branch, correction was simple. This branch, however, arises higher on the nerve than is sometimes realized, and its independent section in injuries to the main division is not uncommon. This is particularly true if the injury also involves the flexor carpi ulnaris tendon, since these structures, throughout their course through the wrist, are never more than 1 cm. apart. If both were injured, any gap present had to be made up by transposition of the nerve at the elbow rather than by flexion at the wrist. If the volar branch alone was involved, small gaps could be overcome by flexion and ulnar deviation of the wrist itself.

Injuries in the hand.—In injuries to the ulnar nerve distal to the annular ligament in the palm, exposure was secured through a modified Z incision across the flexion crease of the wrist to the mid palm. After a flap had been reflected medially, the nerve was isolated in the wrist and followed through the carpal ligament in its compartment to its point of division into deep and superficial branches. Up to this point, repair of the nerve could be done quite readily, by treating the injury of the superficial branch and its digital termination as injuries of the median nerve were treated (p. 399). The deep nerve, however, could seldom be repaired beyond the proximal centimeter.

From the standpoint of sensation alone, the dorsocutaneous branch of the ulnar nerve is more important than the volar, since it supplies the medial surface of the hand and the little finger. These are important areas of contact, particularly when the hand is at rest.

Regeneration of the intrinsic muscles of the hand was most difficult to obtain unless nerve suture was done early and postoperative physical therapy was vigorous. When these criteria were met, results were generally good and atrophy was minimal. It was frequently possible to demonstrate some return of function in the hypotenar muscles and occasionally in the adductor pollicis, but, as always, the interossei and the two medial lumbricales were notoriously poor in their response to surgery.

The Radial Nerve in the Arm

Injuries in the axilla.—The surgical approach to the radial nerve in the axilla was the same as for the lower brachial plexus and the upper portions

of the other main nerve trunks in this area. As was true of other nerves in the neurovascular bundle, lesions affecting the radial nerve at this level were frequently accompanied by other nerve or vascular injuries.

If the lesion was high but below the origin of the upper large branch of the triceps, this branch was always stimulated because it was frequently involved in the same lesion before it entered the muscle. Repair was not difficult.

On the other hand, the axillary portion of the radial nerve was extremely difficult to repair, and its exposure was somewhat more difficult than exposure of the median and ulnar nerves because these nerves, with the artery, had to be retracted medially to permit adequate exposure.

If a gap of any size had to be overcome, it was necessary to adduct the arm and rotate it externally as well as to raise it forward. Because of the necessary approximation of the axilla, the nerve occupied a deep location in the wound, and adequate exposure at this stage was sometimes achieved with difficulty.

Injuries associated with fractures of the humerus.—Lesions of the radial nerve in the next portion, as it passes through the musculospiral groove of the humerus, are very common in peacetime and were also common in war. They were usually associated with fractures of the humerus. An injury at this level, in fact, was uncommon in the absence of bone damage. Fractures of the humerus which were combat incurred were associated with radial nerve paralysis in about 30 percent of all cases. In many instances, the nerve was not completely severed, and recovery was spontaneous.

A radial nerve paralysis associated with a fracture of the humerus, particularly a compound fracture, was an indication for visualization of the nerve when the fracture was reduced, for a number of reasons, as follows:

1. The earliest possible repair of the nerve was desirable if it was severed, though it was always advisable to wait at least 3 weeks from the time of wounding.

2. Investigation of the nerve along with the fracture made it possible to extricate it from a fracture site in which it might be impinged upon by a bony spicule.

3. It was desirable to place it in a new bed, away from the fracture site, to prevent its encasement in callus.

Experience with these injuries in World War II soon showed the advantages of a combined neurosurgical and orthopedic attack, and this policy became almost routine.¹⁴ Previously, the policy had been to delay surgical exploration until the wound had healed sufficiently to permit open reduction of the fracture if that was indicated. Then the attack on the nerve was delayed until after bony healing had taken place, in the belief that spon-

¹⁴ Attention is called to the excellent discussion of combined bone-nerve injuries in the volume in this series of histories entitled "Medical Department, United States Army. Surgery in World War II. Orthopedic Surgery in the Mediterranean Theater of Operations," pp. 116, 128-129, 132-133, and 161.

taneous regeneration might occur in the interim and that, if nerve repair was necessary, there would be less chance of derangement of the bony fragments. The later plan gave priority to the nerve injury.

Ideally, these combined injuries were treated as follows:

After primary debridement, followed by the administration of penicillin, delayed primary wound closure was performed, preferably within 2 to 3 days after the first operation. Combined bone-nerve surgery was carried out about 3 weeks after injury.

Although various incisions were recommended for exposure of the lesions, the most universally satisfactory approach was through medial and posterolateral incisions, with the arm prepared and draped to facilitate freedom of manipulation. The medial incision was made along the course of the neurovascular bundle from the axilla to the mid arm. The contents of the bundle were retracted downward into the area of trauma and scarring. Electric stimulation determined whether the branches of the triceps were intact.

The lateral incision began between the lower end of the biceps and the origin of the brachioradialis and extended upward posteriorly over the course of the radial nerve to a point at about the junction of the middle and upper third of the arm. The nerve could be identified as it penetrated the intramuscular substance and was followed upward into the area of trauma. If the injury was produced by a shell fragment or was associated with a comminuted compound fracture, the triceps muscle was sometimes completely destroyed or was so scarred and distorted that the normal anatomic relations were of little use in guiding dissection.

When the muscle was relatively intact, it might be necessary to sever some of the fibers of the lateral head of the triceps close to its origin in order to preserve the nerve supply, although adequate exposure could sometimes be obtained by retracting these fibers or splitting them. In lesions of longer standing, it might be necessary to use a chisel to free the nerve from extensive callus. Sometimes the mere release of the nerve from such callus was followed by satisfactory return of function.

In a combined bone-nerve injury, the radial nerve, although still in continuity, consisted of frayed, fibrous bands, indicating that a traction or stretch palsy had been caused by displacement of the distal fragment and actual tearing apart of the nerve substance. The damage often extended over several centimeters and resulted in a large defect, which was ordinarily difficult to overcome at this level.

If the nerve was found completely separated and if the bone fragments were in good position and alignment, the proximal and distal ends were mobilized, care being taken to preserve the branches of the triceps, if possible, by stripping them up to the parent nerve. If the gap was small, it might be possible to repair the defect directly by the relaxation produced by flexion of the elbow. For this technique to be successful, the fibers of the triceps

muscle had to lie between the new suture site and the bone. If the gap was large or the scar tissue in the proposed site of repair was excessive, it was frequently advisable to reroute the nerve segment anterior to the humerus, so that the repaired nerve could lie between the brachialis and the biceps.

Some observers believed that the extra length afforded by this rerouting procedure was remarkable. Most believed that it was not. At Halloran General Hospital, which had a particularly wide experience with such lesions (p. 415), a gain of 1.0 to 1.5 cm. was thought the most that could be hoped for. There were, however, two advantages inherent in transposing the radial nerve anterior to the humerus as a technique of repair. One was the improved exposure produced by the transposition for the repair operation. The other was the new bed, free from scar tissue, provided for the regenerating nerve.

In occasional lesions in continuity in which resection and sutures were not required and which were not accompanied by complete fracture of the humerus, the nerve might be brought through the fracture site to the anterior location. The outlook for regeneration was then more promising.

In injuries in which both bone and nerve required surgical attention, the nerve ends were mobilized, removed from the fracture site, and protected by moist cotton while the orthopedic part of the procedure was carried out. Meantime, the site of probable resection of the neuroma and glioma had been estimated, and, if the defect to be overcome was too great to be made up by ordinary means, the additional distance was recovered in the repair of the bony fragment. A shortening of not more than 3.5 to 5 cm. was usually not difficult to attain. In some instances, it facilitated bony repair and secured firmer union. The bone fragments were fixed in place by a plate (fig. 195), a graft, or some other technique of internal fixation.

The nerve was then repaired, care being taken that the course selected for it avoided irregularities and extraneous agents used in the repair of the bone. Relaxation from flexion of the elbow could be further increased by adduction of the arm. Fixation by a Velpeau dressing was satisfactory. When more rigid fixation was required because of operation on the bone, a plaster shoulder spica was frequently used.

Injuries in the distal third of the arm.—Lesions in the radial nerve in the distal third of the arm were more readily accessible to surgical repair. When the injury was associated with a fracture of the lower third of the humerus, the bony injury was not likely to be as severe as in the injuries just discussed.

In this part of the arm, the radial nerve lies between the brachioradialis laterally and the biceps and brachialis medially. If it was necessary, it was identified above the intermuscular septum and followed downward. Care was taken to preserve the branches of the brachioradialis and the extensor carpi radialis. These two nerves sometimes formed a large motor trunk. If it was destroyed, along with the parent nerve, they could be repaired inde-

pendently. If it was necessary to suture them to the nerve, it had to be remembered that these fibers arise from the fascicles on the lateral aspect of this structure.

The distal segment could be found by identifying the superficial radial nerve in the forearm and following it up to its junction with the posterior interosseous to form the common trunk. The proximal segment had to be mobilized thoroughly, since the course of the posterior interossei through the supinator considerably restricts the mobilization of the distal segment unless branches are sacrificed.



FIGURE 195.—Roentgenograms of fracture of humerus. A. Nonunion. B. Repair of fracture after 5 cm. shortening by use of bone plate. The tantalum sutures employed to repair the radial nerve may be seen near the head of the screw second from the elbow.

The Radial Nerve in the Forearm

In the forearm, the sensory division of the radial nerve (the superficial radial nerve) lies under the brachioradialis. Because of its sensory distribution, the autonomous area of which is very small, this nerve is not of surgical importance, though it was occasionally used in World War II as a cable graft to other nerves in the arm. It was sometimes attacked surgically because of the annoyance produced by neuromas along its course.

The posterior interosseous nerve is important because of its function in opening the hand. It was frequently injured during operations for removal of the head of the radius after fracture. Its exposure and repair required considerable dexterity.

Its exposure in the upper portion, before it enters the supinator muscle, was accomplished by extension of the incision to expose the lower portion of the radius in the upper arm. The incision was made to curve laterally, to

avoid crossing the flexion crease of the elbow in a straight line. By traction on the brachioradialis and extensor carpi radialis, the nerve could be followed into the supinator. For additional exposure, a straight incision was made over the dorsum of the forearm, between the extensor carpi radialis and the extensor digitorum communis. After the fascia had been opened and the plane followed between these two muscles in the upper portion of the incision, the fibers of the supinator could be identified, and, after section of the superficial portion, the nerve could be seen coming from the lower portion of this muscle.

If the injury was within the muscle itself, the upper portion of the nerve was identified through the exposure just described. The distal segment was identified at the lower border of the supinator, where the nerve breaks up into its numerous branches.

Defects in this region could be repaired quite readily by mobilizing the proximal segment from above, at the point at which it was most often injured during surgical attack on the head of the radius. Because of the size of the branches and the difficulty of repairing them, it was important to remember the surgical significance of the two separate clusters (the proximal branches to the extensor digitorum communis and extensor carpi ulnaris and the distal branches to the abductor pollicis longus, extensor pollicis longus, extensor pollicis brevis, and extensor indicis proprius). A lesion which destroyed one cluster might spare the other, and a surgical repair might salvage either one.

Disability of the hand was not only minimized but its physiologic restitution was more easily accomplished in this region by tendon splitting than by transposition of flexor tendons. The technique recommended by Albritten,¹⁵ with intraneural dissection of the branches of the supinator and superficial extensors, permitted mobilization of the proximal segment distally through the supinator by flexion of the elbow. The surgeon was thus enabled to overcome almost any reasonable gap that might occur in the dorsal interosseous nerve.

In the past, the satisfactory results obtained from tendon transplants somewhat dampened enthusiasm for extensive surgery to correct defects of the posterior interosseous nerve. In World War II, the satisfactory results which followed surgical repair of the nerve sufficiently outweighed the physiologic results from tendon transplants to warrant the more frequent use of surgery.

The Femoral Nerve

The wartime experience with repair of the femoral nerve was not wide. One reason was that few such injuries were seen because of the high fatality rate attendant upon associated injuries of the accompanying femoral artery.

¹⁵ Albritten, F. F., Jr.: The Surgical Repair of the Deep Branch of the Radial Nerve. *Surg. Gynec. & Obst.* 82: 305-310, March 1946.

Another was the relatively short course of this nerve in the leg before it breaks up into its numerous branches. Partial lesions were more likely to be injuries of the branches in the mid thigh than injuries of the main nerve in the groin.

Preoperative examination usually gave the surgeon some idea of the portion of the quadriceps chiefly affected. Whenever localized atrophy was present, surgical exploration usually revealed that suture was warranted.

The incision for repair of the femoral nerve or any of its branches was made just lateral to the femoral artery. It extended downward over the sartorius, along the medial border of the rectus femoris. When the sartorius muscle was mobilized and reflected laterally, the principal branches of the nerve were disclosed, and affected branches could be followed downward to the point of injury. It was frequently possible to identify the distal segments of the branches, and anastomosis could be completed by mobilizing the proximal segment and flexing the thigh until the patient was in a sitting position. Plaster fixation in this position was well tolerated. A window was left open over the anterior thigh to use for galvanic stimulation of the quadriceps muscles, which atrophy rapidly from disuse. If the lesion was only partial, quadriceps exercises within the cast were encouraged.

The Obturator Nerve

Injuries of the obturator nerve were even more uncommon than injuries of the femoral nerve. This nerve, after passing through the obturator foramen, soon breaks into muscular branches, which explains why deficits of the entire nerve were seldom seen.

Surgery upon the pelvic portion of this nerve was not uncommon in military practice, particularly in the treatment of paraplegics, in whom adductor spasm could be a disabling complication. The nerve could be isolated through a suprapubic incision as it enters the upper part of the obturator foramen after passing along the outer wall of the lesser pelvis. Its identification was facilitated by the use of the electric stimulator. Simple section was frequently accompanied by section of the pelvic adductor attachments.

The Sciatic Nerve

Surgery on the sciatic nerve was facilitated by the fact that it is by far the largest nerve in the body. From the standpoint of surgical anatomy, it was important to remember that the peroneal portion of the nerve occupies its posterolateral aspect and, because of its location, was particularly vulnerable to trauma in certain areas, such as its course under the gluteus. The lateral portion of the nerve was also frequently injured in dislocations of the hip. It was not unusual for surgeons, in error, to assume that a peroneal palsy which was present was the result of pressure on or trauma

to the peroneal nerve at its most exposed point over the head of the fibula, especially since injuries which produced dislocations of the hip were likely to be accompanied by trauma elsewhere in the leg.

Injuries in the upper portion.—The sciatic nerve was exposed in its upper portion through a gluteal-reflecting incision and in its lower portion through a vertical incision in the thigh, the location of the incision depending upon the level of the lesion. If the injury was at the gluteal fold, the vertical incision in the midline of the thigh could be extended laterally, following the gluteal fold; only the lower fibers or the femoral attachments of the gluteus were reflected. If, however, the gap in the nerve was great, it was frequently necessary to combine the two exposures and mobilize the nerve in its entirety.

To secure this exposure, the patient was placed prone, and the entire leg and buttock, as well as the lower lumbar region, were thoroughly prepared. Drapes were either stitched or clipped to the medial portion of the buttocks, to prevent contamination, which was always a serious risk in this area.

The operation was begun under local anesthesia, which was continued until the status of the nerve was evaluated. It was then continued under continuous spinal anesthesia, administered through a malleable needle or an ordinary spinal needle with a shield.

Exposure was secured by the ?-shaped curve recommended by Stookey.¹⁶ It extended from the level of the posterior iliac spine outward and downward to the trochanter of the femur. After passing downward over the insertion of the gluteus maximus tendon, it curved medially again along the gluteal fold to the midline of the thigh. It was then extended downward over the course of the sciatic nerve as far as the requirements of the special case indicated.

The fascia was opened, and the fibers were split above the trochanter in the direction of cleavage. The muscle was followed to its termination in the thick, tendinous band which passes across the greater trochanter over a bursa and is inserted into the iliotibial tract of the fascia lata. This band was cut along its tendinous portion. After the few fibers requiring transection in the attachment of the muscle to the femur and the few blood vessels which required ligation had been cared for, the whole muscle could be reflected medially and held in retraction by an assistant. The inferior gluteal vessels and nerves could then be seen on the undersurface of the muscle, and measures were taken for their protection.

The sciatic trunk was now exposed. The injured portion was likely to be encased in scar tissue which obscured the nerve through most of its subgluteal course. When this condition was present, the nerve was isolated at the lower border of the gluteus, where it is most superficial, and the branches to the hamstrings were identified and stimulated. The nerve was then followed upward into the region of maximum scarring. Dissection

¹⁶ Stookey, Byron: *Surgical and Mechanical Treatment of Peripheral Nerves*. Philadelphia and London: W. B. Saunders Co., 1922.

was simplified by the fact that there are no branches given off by the sciatic nerve in this region between the branches to the hamstrings and the inferior gluteal nerve above.

The sciatic nerve was isolated in the region of the sciatic notch and was followed downward. If the injury was in the region of the notch, the piriformis muscle was likely to be involved in the scar tissue; if it was, it was transected. Otherwise, it was separated from its insertion and reflected. The inexperienced surgeon had to guard against a common error in this stage of the procedure, identification of the greater trochanter and the ischial tuberosity as the lower border of the sciatic notch. These structures are at about the midpoint of the subgluteal exposure.

If the sciatic nerve injury was in the notch and the piriformis had to be transected, care had to be taken not to injure the superior gluteal vessel and nerve as they emerged above this muscle. Dissection of the piriformis, neurolysis, and even nerve suture could be successfully accomplished at the level of the sciatic notch. In dissection at this level, however, extreme care had to be taken to isolate the gluteal vessels. Accidental opening of one of these vessels at or slightly above the level of the notch might resist all efforts at control of the bleeding from below and requires an anterior pelvic approach for ligation of the lower portion of the internal iliac artery. This approach was frequently employed in aneurysms of the subgluteal artery associated with sciatic palsy from pressure.

Gaps in the subgluteal region of the sciatic nerve could be overcome by mobilizing the distal segment of the nerve, flexing the knee, and extending the thigh at the hip. This maneuver, however, did not solve the problem if the branches to the hamstrings were involved as they came off the common trunk. Lesions in this area, as well as in the lower portion of the sciatic nerve, were more likely to be partial than complete. Whether the primary components of the nerve were involved totally or in part, the tibial and peroneal portions of the nerve were separated from each other to facilitate neurolysis through the neuromatous portion and to permit more accurate approximation of the divided fascicles of each segment. The involved component of the nerve or the fascicles was painstakingly dissected from the intact portion for a distance sufficient to permit approximation of the prepared fascicles without causing too much kinking in the intact, relaxed segments.

Repair was best accomplished by metallic sutures. If they were not used, metallic markers were placed at measured distances on each side of the anastomotic site, to permit later roentgenologic studies of the integrity of the suture line. In injuries of the sciatic nerve, it was always best to have a spica plaster cast prepared and bivalved before operation, to minimize the risk of loss of position during its application after operation.

Injuries in the lower portion.—Exposure and repair of the sciatic nerve are less difficult in the lower portion of the thigh, in which no important nerve branches are given off except those from the peroneal portion to the

short head of the biceps femoris. The nerve is readily exposed through a midline incision.

In the upper thigh, the long head of the biceps femoris crosses the sciatic nerve obliquely from the medial aspect above to the outer aspect below. When the muscle was retracted medialward in the upper half of the thigh and laterally in the lower thigh, the nerve was completely exposed. It facilitated the mobilization of the muscle belly to isolate it and place a tape around it.

Special technical points.—In its course through the thigh, the sciatic nerve lies on the adductor magnus, in a deep muscle trough between the hamstrings. The lesser sciatic nerve lies in the fascia, which placed it under the incision in the upper portion, near the gluteal fold. The fascia was incised at a sufficient distance from it to avoid including it with the sutures in the closure.

In all lesions of the sciatic nerve, whether partial or complete, suture was preceded by complete separation of the two components for a distance of several centimeters above and below the level of repair. The same procedure was of definite advantage in neurolysis. If a line of division was not obvious, it could usually be found by palpation of the nerve between the thumb and fingers. If it was not identified by this means, the nerve was isolated at the point of its bifurcation and was dissected upward, with due care to protect the fascicles and blood supply of each component.

In complete transections of the sciatic nerve, there was frequently sufficient distortion and rotation present for the segments to be isolated sufficiently far from the injury to establish the normal dorsolateral position of the peroneal component and the ventromedial position of the tibial component. Normally, the sciatic nerve under the gluteus is surrounded by a large amount of loose areolar tissue, so little was usually gained by extensive exposure of this portion. If a large gap had to be overcome, the popliteal fascia was opened widely. If the tibial component was involved, it was mobilized to a more superficial location in the popliteal space. If the peroneal component was involved, it was freed to the head of the fibula; in some cases, it was advisable to resect the neck of the fibula.

The nerve components were then repaired independently, to avoid the risk of crossing fibers. Whenever the gap in the peroneal portion was more than 4 to 5 cm., a relaxation stay or sling suture was placed through the parts for additional support. Neuropathologic studies showed that tantalum or stainless steel produced the least tissue reaction. A thread of 0.005 inch was adequate. If the gap in each of the components was about the same in extent, it was frequently possible to place the sling stitch through the septum dividing them, thus avoiding injury to any of the fascicles. This was a wise precaution, for it was estimated that separation of the suture site could be anticipated in about 25 percent of all cases.

The Peroneal Nerve

Independent injuries to the main components of the sciatic nerve were more likely to occur above the popliteal space, just above which the two main nerve trunks begin to diverge. The smaller, lateral component, the common peroneal nerve, is quite simple and is easily accessible throughout its course. Small gaps were readily overcome by simple flexion of the knee. Larger gaps, although they might be overcome equally easily, were frequently prone to disruption or to traction paralysis, with further tissue destruction. This was because of the unusual mechanical stresses exerted on the nerve, which has one fixed point over a bony prominence and then passes in an almost straight line along the sciatic nerve to its point of emergence from the sciatic notch. Any stretch here is not alleviated by any intervening soft tissue and must be compensated for by the elasticity of the nerve itself. More favorable conditions were sometimes produced by resecting the neck of the fibula, which permitted the nerve to assume a more medial position and provided it with a more direct course from the popliteal space to its distribution in the anterior muscles of the leg. The course of the nerve was thus slightly shortened, and the stretch pull was alleviated by the soft tissue of the muscle rather than by the bone.

During the war, an incision for exposure of the peroneal nerve was developed which was a definite improvement over the incision formerly employed, which followed the flexion crease of the knee. The limb was prepared and so draped that the lower leg could be freely mobilized. Then the knee was flexed acutely, and a line of incision outlined from the midpoint of the lower thigh downward to a point well above the flexion crease of the knee. Here the incision was swung laterally. Slight medial retraction of the skin flap exposed the peroneal nerve satisfactorily, and the awkwardness and inconvenience attendant upon attempts to close the older type of incision after flexion of the knee to obtain relaxation were eliminated.

Two other points were important in repair of injuries of the peroneal nerve. The first was that the nerve be isolated after its bifurcation into superficial and deep divisions and the distal segments be followed upward, to correct any funicular distortion produced by trauma and permit appropriate fascicles to be approximated with each other. The second was that the proximal segment be mobilized by incision of the deep fascia and further separation from the tibial nerve.

Although the common peroneal nerve was most often injured in its passage around the head of the fibula, injuries of the deep and superficial peroneal nerves, either in combination or singly, were not infrequent. Gaps in the upper portion of the superficial nerve could be overcome by mobilizing the proximal segment, after splitting the two terminal portions of the peroneal nerve for a distance of several centimeters.

Surgery was seldom performed below the branch of the extensor digitorum longus because of the extensive dissections necessary for mobilization

sufficient to overcome a gap of any length. Recovery of the extensor function of the great toe was better accomplished by a split tendon transplant.

Injuries of the common peroneal nerve over the head of the fibula frequently required isolation of both the deep and superficial peroneal nerves independently. They were then sutured into the common peroneal trunk, which was brought down from the popliteal space.

The Tibial Nerve

In view of its size and importance, injuries of the tibial nerve were neglected in a surprising number of cases. This was probably because they were so often overlooked and undiagnosed, at least in some locations.

Injuries of the tibial nerve in the popliteal space, above the origin of the branch of the gastrocnemius, were easily recognized and repaired. In this location, mobilization of the distal segment was somewhat restricted because of the limitations imposed by the branches to the gastrocnemius, but a considerable gap could usually be overcome by flexion of the knee. Also, it was sometimes advantageous to separate the tibial from the peroneal portion of the sciatic nerve for several centimeters, to afford better mobilization of the proximal segment.

The surgical approach in this location was through a straight incision, the continuation of the incision used for exposure of the sciatic nerve. Extension of the incision medially over the medial hamstrings, in the form of a flap, greatly facilitated closure if the nerve suture required flexion of the knee for relaxation.

If the injury was between the heads of the gastrocnemius but above the origin of the soleus, the two heads of the gastrocnemius were divided to improve the exposure.

Injuries of the posterior tibial nerve below the level at which branches are given off to the plantar flexors of the foot were frequently overlooked. Experience in civil practice showed that a complete lesion at this level was sometimes not recognized until years after the injury, when the patient presented himself with trophic ulcers on the ball of the foot, loss of intrinsic muscles, and undue prominence of the metatarsal heads, which sometimes had eroded through the anesthetized skin. Flexion of the toes was greatly diminished or completely lost, and ability to invert the foot, with stabilization of the ankle, was also lost if the lesion was above the origin of the branch to the tibialis posterior.

Lesions seen in military practice had not, of course, reached this stage, and in several instances gaps of extraordinary length—several 10 cm. long and another 16 cm. long—were repaired. The technique was as follows:

The patient lay prone on the table. The surgeon took his position on the side of the table opposite the injured limb. The skin incision was an extension of the incision used for an injury of the tibial nerve in the popliteal space. It curved around the medial angle of the flexion crease of the knee,

extended slightly posteriorly, and then continued just posterior to the medial border of the tibia downward to the ankle, where it passed midway between the medial malleolus and the tendo achillis. Finally, the incision followed the course of the nerve into the foot.

The saphenous vein and nerve were identified after the skin was opened and were protected as much as possible; when the incision in the fascia was closed later, care was taken not to strangle the nerve in the suture. The fascia was opened in line with the skin incision. In the lower half of the leg, the separation was between the soleus and gastrocnemius muscles posteriorly, as they join to form the tendo achillis, and between the flexor digitorum longus and the tibialis posticus anteriorly. Above this point, the narrow attachments of the medial border of the soleus muscle were separated from the posterior medial surface of the tibia. The upper attachment of the soleus was separated from the oblique popliteal lines of the tibia as far as the tendinous arch, which was opened laterally. When this dissection had been completed, the soleus and gastrocnemius muscles could readily be retracted laterally en masse, with their nerve and blood supply. The neurovascular bundle was thus exposed under the deep layer of the fascia on the posterior surface of the tibialis posticus muscle, within the groove between the flexor digitorum longus and the flexor hallucis longus muscles.

The main trunk of the posterior tibial nerve was picked up distally at the anterior medial border of the tendo achillis, just above the internal malleolus. Stimulation of the nerve at this point usually indicated whether the lesion was partial or complete. The nerve was identified proximally, either at the popliteal space or at the level of the tendinous arch of the soleus, and dissection of the segments was carried out proximally and distally through the scar tissue until the proximal neuroma and distal glioma were encountered.

It was frequently possible to preserve the nerve supply to the deep flexors as well as to the gastrocnemius and soleus, even though the lesion was quite high, since these branches come off high in the calf or even in the popliteal space. More often, the two lowest branches of the muscles of the calf, the flexor hallucis longus and the flexor digitorum longus, were involved. For adequate mobilization, these branches had to be separated from the proximal portion of the posterior tibial nerve by careful intraneural dissection. If these branches were dissected after they came from a common fasciculus and if the dissection was carried up to the popliteal space, the branches to the soleus and the gastrocnemius were also exposed. At this level, these branches were sometimes as large as the rest of the posterior tibial nerve. During the dissection, great care was taken to protect the posterior tibial artery and its branches through the muscles of the calf.

In occasional injuries in which the gap to be overcome was excessive, a few more centimeters could be obtained by withdrawing the proximal end from between the heads of the gastrocnemius and extending it down the leg superficially to the medial border of the soleus.

When considerable dissection was necessary above the knee, it was a good plan to close the upper part of the wound as far as possible before flexing the knee to facilitate nerve suture.

After the nerve was repaired, the soleus was resutured to its attachment at the tibia in the upper half of the leg with interrupted sutures of fine silk. The wound was then closed in the usual manner.

It was generally agreed that the approach just described was less traumatic and sounder physiologically than the midline incision which requires splitting of both the gastrocnemius and the soleus.

The posterior tibial nerve, like the median nerve, has an unusually large number of sensory and autonomic fibers to the sole of the foot and the toes. Causalgia was frequent after injuries to both nerves. It was always associated with partial lesions in continuity and was therefore not regarded as an indication for resection and suture, since the function of the affected nerve was often quite good and the symptoms could be well controlled by sympathectomy.

CHAPTER XVI

Combined Bone and Peripheral Nerve Injuries

Wade C. Myers, Jr., M.D., and Robert T. Rosenfeld, M.D.

GENERAL CONSIDERATIONS

When the problems of a combat-incurred peripheral nerve injury were added to the problems of a serious bone injury in the same extremity, both neurosurgeons and orthopedic surgeons were often confronted with a very difficult situation. The original policy of treating the skeletal injury first and relegating the nerve injury to second place gave unsatisfactory functional results, and it is unfortunate that the policy eventually evolved of treating the injured extremity rather than of treating the separate structural injuries was not established earlier.

The experience at the neurosurgical center at Halloran General Hospital, Staten Island, N.Y., with these combined injuries is typical of the general experience. In February 1945, the policy of combined neurosurgical-orthopedic management of combined bone and nerve injuries was set up at this center. Patients with these injuries were segregated in special wards, and their care was made the joint responsibility of the orthopedic surgeon and the neurosurgeon.

The new policy was based on the principle, by then thoroughly established, that nerve injuries must be sutured as soon as possible after wounding if maximum functional recovery is to be obtained. In practice, this meant that nerve repair was performed as soon as possible after healing of the soft-tissue injury. Primary repair of combat-incurred nerve injuries was never considered practical in World War II.

Policies were completely flexible and depended upon the exigencies of the individual case. In some instances, neurosurgical and orthopedic procedures were carried out at the same operation. In some instances, nerve lesions were repaired before the fracture had solidly united or before sufficient time had elapsed after wound healing to permit a reconstructive bone operation. In some instances, in which the bone injury had resulted in ankylosis, it was necessary to perform reconstructive orthopedic surgery to permit flexion of the joint before the severed nerve ends could be approximated. Whatever the plan for the special case, the important consideration was that its management was the joint responsibility of the neurosurgeon and the orthopedic surgeon.

This chapter is chiefly based upon the 36 combined bone-nerve injuries which were repaired at single operations at the Halloran General Hospital Neurosurgical Center in 1945 (table 11). Over the same period, several hundred patients with less serious injuries of the same kind recovered under conservative management, and in a smaller number of cases, which are briefly discussed, surgery for the nerve injury and the bone injury was performed at separate procedures. The important consideration, as already pointed out, was that in all of these cases, no matter how they were managed, the approach was total, and the treatment, no matter how it was carried out, was a joint neurosurgical-orthopedic responsibility.

The combined treatment of neurosurgical-orthopedic injuries offered many advantages, aside from the obvious one that there were no administrative delays in transferring patients from one section to another. The neurosurgeon was able to evaluate the nerve injury promptly and to perform early nerve repair with the assurance that the bone injury was under competent supervision and management. Adequate fixation of the fracture not only expedited bony union but also helped to prevent disruption of the suture site in the nerve. When the bone injury also had to be managed surgically, the patient was subjected to only one major surgical procedure instead of two, with a resultant decrease in morbidity and shortening of hospital-stay days, and a consequent increase in his morale. From the practical standpoint, the bone shortening possible under the plan of combined operation often permitted more satisfactory nerve repair. The experience at all neurosurgical centers was that the plan of combined management offered the optimum chances for satisfactory functional recovery in nerve injuries complicated by orthopedic injuries.

SELECTION OF CASES FOR COMBINED OPERATION

Orthopedic and neurosurgical procedures were carried out at the same operation when the following conditions existed:

1. When continuity of the bony structure was necessary to prevent separation of the repaired nerve. This was particularly necessary when the bony defect was in the femur or the humerus and the nerve defect was in the sciatic or in the radial, ulnar, or median nerves. Without effective stabilization of the bone by grafting, distraction of the bony fragments frequently caused separation of the suture site.

2. When shortening of the humerus was necessary to permit suture of the nerve because the gap in the nerve was too wide to permit union by any technique of repair. In 10 cases thus treated at Halloran General Hospital, all instances of radial nerve injury, pathologic changes in the humerus would have required resection, regardless of the nerve injury. In another case, not included in the series, a normal humerus was shortened 1.75 cm. because it would otherwise have been impossible to approximate the severed ends of the radial, median, and musculocutaneous nerves, all of which were completely

TABLE 11.—Summarized data in 36 combined bone-nerve operations performed at Halloran General Hospital Neurosurgical Center, 1945

Nerve and case number	Months after suture	Operation	Muscle function			Tinel's sign	Autogenous zone sensation
			Brachio-radialis	Extensor carpi longus	Extensor digitorum communis		
Radial nerve:							
Case 1.....	7. 5	Neurorrhaphy.....	+	+	1 +	Complete.....	Superficial.
Case 2.....	9	do.....	+	+	1 +	do.....	Do.
Case 3.....	8	do.....	+	+	1 +	39 cm.....	Do.
Case 4.....	8	do.....	+	+	1 +	Complete.....	Do.
Case 5.....	7. 5	do.....	+	+	1 +	do.....	Do.
Case 6.....	9	do.....	+	+	1 +	do.....	Do.
Case 7.....	7	do.....	+	+	1 +	do.....	Do.
Case 8.....	10	do.....	+	+	1 +	do.....	Do.
Case 9.....	9	do.....	+	+	1 +	do.....	Do.
Case 10.....	7	do.....	+	+	1 +	41 cm.....	Do.
Case 11.....	8	do.....	+	+	1 +	Complete.....	Do.
Case 12.....	6	do.....	+	1 +	1 +	26 cm.....	Deep.
Case 13.....	1	Neurolysis.....	+	+	1 +	Complete.....	Complete return.
Case 14.....	6	Neurorrhaphy.....	-	-	-	(²).....	(²).
Case 15.....	6	do.....	-	-	-	(³).....	(³).
Case 16.....	6	Exploration.....	-	-	-	(⁴).....	(⁴).
Case 17.....	6	do.....	-	-	-	(⁵).....	(⁵).

See footnotes at end of table.

TABLE 11.—Summarized data in 36 combined bone-nerve operations performed at Halloran General Hospital Neurosurgical Center, 1945—Continued

Nerve and case number	Months after suture	Operation	Muscle function			Tinel's sign	Autogenous zone sensation
			Extensor communis digitorum	Extensor carpi ulnaris	Extensor pollicis longus		
Dorsal interosseous nerve:							
Case 1	6	Neurorrhaphy	--	--	--	--	(6)
Case 2	6	do.	--	--	--	--	(6)
Nerve and case number	Months after suture	Operation	Muscle function			Tinel's sign	Autogenous zone sensation
			Flexor carpi ulnaris	Abductor digiti quinti	Adductor pollicis		
Ulnar nerve:							
Case 1	10	Neurorrhaphy	+	+	+	Complete	Deep.
Case 2	6	do.	Injury below motor branch.	do.	do.	do.	Do.
Case 3	5	do.	do.	do.	do.	do.	Do.
Case 4	6	do.	do.	do.	do.	do.	Do.
Case 5	7	do.	do.	do.	do.	do.	Superficial.
Case 6	7	do.	do.	do.	do.	do.	Deep.
Case 7	6	do.	do.	do.	do.	do.	Do.
Case 8	6	Neurolysis	do.	do.	do.	do.	Superficial.
Case 9	6	do.	do.	do.	do.	do.	Do.

Nerve and case number	Months after suture	Operation	Muscle function		Tinel's sign	Autogenous zone sensation
			Abductor pollicis brevis	Opponens pollicis		
Median nerve:						
Case 1	6	Neurorrhaphy	+	+	Complete	Superficial.
Case 2	6	Neurolysis	+	+	do	Do.
Case 3	6	do	+	+	do	Do.
Case 4	6	do	+	+	do	Do.
Sciatic nerve:						
Nerve and case number	Months after suture	Operation	Muscle function		Tinel's sign	Autogenous zone sensation
			Tibialis anticus	Gastrocnemius		
Case 1	6	Neurolysis	+	+	Complete	Superficial.
Case 2	8	Neurorrhaphy	1+	1+	58 cm.	None.
Case 3	9	do	+	+	70 cm.	Do.
Case 4	10	do	1+	+	68 cm.	Do.

¹ Galvanic-tetanus ratio greater than 2.0, indicating that regenerating nerve fibers had reached originally denervated muscle.

² Failure. Extensive cellulitis with abscess formation 10th postoperative day.

³ Failure. Poor ends, no return.

⁴ Inoperable. 18-cm. defect found at exploration.

⁵ Inoperable. 18-cm. defect found at operation.

⁶ Not lost, but there was no return of muscle function.

paralyzed. It was not the policy to shorten the normal humerus for injury of the radial nerve alone; in this type of case, satisfactory results could be obtained by tendon transplantation.

3. When reconstructive bone surgery was necessary and the interval since wound healing was sufficient to make the combined bone-nerve procedure safe. The combined procedures in this category were most often done in the forearm, when the ulnar or median nerve required repair and the damaged radius or ulna had to be managed by bone graft.

Timing of operation.—The neurosurgeon preferred to operate as soon as possible after satisfactory healing of the soft-tissue wound. Theoretically, the orthopedic surgeon considered a 3-month interval between wound healing and reconstructive surgery ideal. Practically, when there had been no evidence of infection involving the bone, a 2-month interval proved entirely adequate. If infection was present and of long standing, even a 3-month interval was not sufficient.

In numerous instances, it was possible to perform the nerve repair earlier than the orthopedic operation; reinfection was less likely in a soft-tissue wound, and, if it should occur, was of less consequence than when the bone was involved. In such cases, the policy was to perform neurosurgery at the earliest possible date and defer bone surgery until a later date; because it was less urgent than early nerve repair, it could afford to wait a more ideal time. This policy was particularly important in injuries of nerves of the forearm, in which bone shortening was not considered advisable.

In the Halloran General Hospital series, the average time between injury and complete wound healing was 2.5 months, the range being 10 days to 6 months, and between injury and reconstructive surgery 5.1 months. The shortest interval between wounding and reconstructive surgery was 1.5 months; in this case, only nerve surgery was done. The longest interval was 9 months.

PREOPERATIVE MANAGEMENT

Immobilization.—Patients with compound fractures of the humerus were usually received in Zone of Interior hospitals in shoulder spicas, which had been found most satisfactory for transportation splinting. These casts were removed, and hanging casts were substituted as promptly as possible. The early use of an anterior molded splint, in place of a full plaster cast, permitted the daily removal of the extremity from the splint for physiotherapy and muscle-stimulating exercises. The policy of early motion prevented excessive muscular atrophy and kept the skin in favorable condition for operation. No instance of nonunion could be attributed to this form of treatment.

Patients with fractures of the femur and the knee joint were usually received from overseas in hip spicas. On their arrival in the Zone of Interior, these casts were removed, and traction suspension was substituted.

Skin traction was satisfactory in most cases. Skeletal traction was used if the fracture was markedly displaced or malaligned. In limbs which presented a mere bowing deformity, it was usually possible to correct the bowing by vertical skin traction, with supplementary lateral traction by slings. In the majority of cases of marked deformity, however, too great an interval had elapsed between injury and admission of the patient to the Zone of Interior hospital to permit correction of the deformity by traction, particularly when there was overriding. Surgical measures were usually required in such cases.

Fractures of the tibia were treated by the application of a plaster posterior molded splint as soon as possible. As in fractures of the upper extremity, the injured limb could be removed from the cast daily for physiotherapy, which included massage, mobilization of the joint, electrical stimulation, and skin conditioning. No instance of nonunion could be attributed to this form of treatment.

Management of septic compound fractures.—Patients who arrived at the hospital with draining wounds caused by bone infection were examined and evaluated from the neurosurgical standpoint, but the primary problem in these cases was orthopedic. Transportation casts were removed. Wounds were inspected and cultures made. Roentgenograms were also made.

Measures were then instituted to expedite healing of the fracture. Sequestrectomy, secondary wound closure, skin grafting, and revision of the scar were employed as indicated. Penicillin was used as an adjunct to surgery, and liberal plasma and whole blood transfusions were given according to the indications. Every effort was made to maintain a sound nutritional status by a diet high in proteins and vitamins.

About 28 percent of all patients with orthopedic-nerve injuries were received at Halloran General Hospital with draining wounds. The average interval between wounding and their arrival at the hospital was 12 weeks, the range being 2 to 23 weeks.

In septic compound fractures, operation was practically always deferred for 6 months or more after wounding; if the infection had been particularly obstinate, a still longer delay was necessary.

Care of the skin.—Particular attention was paid to the condition of the skin before operation. Dense and adherent scars were resected, and skin grafting by means of pedicle flaps was employed if the wound could not be closed satisfactorily after excision of the scar. The Potter and Croce technique of performing a neurosurgical procedure and applying a pedicle flap at the same operation (p. 430) was sometimes very useful.

OPERATION

When combined nerve-bone reconstructive surgery was performed, operation was carried out according to a carefully planned routine, the steps of which were as follows:

1. The neurosurgeon made the initial incision, isolated the nerve, mobilized it as freely as possible, and resected the ends as far back as necessary to reach healthy nerve tissue. He also measured the defect which existed with the joint flexed, to determine whether bone shortening would be required, and, if it were necessary, how much nerve tissue must be resected.

2. The orthopedic surgeon then initiated the orthopedic procedure. Experience showed that, because of the additional handling of the extremity following the orthopedic operation, exceptionally firm fixation was necessary. For this reason, both a plate and a graft were frequently used, tibial cortex usually being employed for the latter purpose. The graft was fixed in place with metal screws, and multiple bone chips and a generous amount of cancellous bone were packed around the fracture site.

3. The neurosurgeon, at the completion of the orthopedic procedure, repaired the nerve lesion. In all instances of complete nerve section, end-to-end neurorrhaphy was performed with interrupted epineurial sutures of 0.003-inch tantalum wire. The suture site was usually enclosed in a 2-cm. length of tantalum foil. If nerve section was not complete, neurolysis was performed.

4. After the neurosurgeon had closed the wound, the orthopedic surgeon applied the plaster splint.

5. The nerve and orthopedic procedures were always performed through different muscle planes, so that excessive scar formation would not endanger the chances of nerve recovery.

Anesthesia.—The first neurosurgical phase of the operation was usually performed under local anesthesia, secured with procaine hydrochloride (1-percent solution), so that the results of stimulation of the exposed nerve could be properly evaluated. General anesthesia was not begun until the orthopedic stage was reached. Combined bone-nerve operations were frequently very long, but the plan described meant that there was no undue prolongation of the anesthesia.

ANALYSIS OF DATA

Management of Regional Injuries

Upper arm.—Of 18 patients with compound comminuted fractures of the humerus who underwent combined bone-nerve surgery, 17 presented paralysis of the radial nerve and the other paralysis of the ulnar nerve.

In 10 cases, all instances of radial nerve injury, shortening of the humerus was necessary, the average resection being 4.1 cm. and the lower and upper limits 2.5 and 6.5 cm., respectively.

Neuromas in continuity were found in the single ulnar nerve injury and in six of the radial nerve injuries. The average gap in the nerve after excision of the neuroma was 6.1 cm., the range being 5 to 6.6 cm. These (and all other) measurements of the nerve defects were made with the

elbow in 90° flexion. In the remaining cases, the average gap after excision of damaged tissue was 6.6 cm., the range being 5.2 to 10 cm. In many cases, the character of the injury was responsible for the length of the defect. In other cases, prolonged preoperative immobilization had resulted in considerable restriction of motion of the elbow.

The bone injury in all 18 cases consisted of nonunion, malunion, or limited union; the fracture had united in many cases, but the bone mass was insufficient to permit good function and assure safety from refracture under moderate stress.

Neurorrhaphy was performed in 14 of the 17 radial nerve injuries and in the single ulnar nerve injury. Neurolysis was adequate in one case, and the damage in the two remaining cases was inoperable.

In seven instances of radial nerve involvement, the nerve was transplanted anteriorly (figs. 196 and 197). The usual lateral incision was made, and the nerve was freed to the posterior aspect of the humerus in the musculospiral groove. An incision was next made on the medial aspect of the arm over the neurovascular bundle in its upper portion, and the nerve was dissected free from the medial aspect. It was then passed distally between the brachialis muscle and the biceps. This technique provided a satisfactory new bed for the radial nerve when there had been extensive soft-tissue damage in the normal bed and also provided an additional 1 to 1.5 cm. in the length of the nerve.

In the 10 cases of radial nerve injury in which shortening of the humerus was necessary (p. 416), the average resection was 4.1 cm. In the case (not included in this series) in which the normal humerus had to be shortened (p. 416), resection of a neuroma left a gap of 1.75 cm. Of necessity, the humerus was shortened by the same length and then was fixed with a Vitallium plate.

Forearm.—In the four median nerve injuries associated with fractures of the humerus, the bone was repaired by grafting in all instances. The nerve was managed by neurorrhaphy in one case and by neurolysis in the other three cases. Neurorrhaphy was also necessary in the four ulnar nerve injuries associated with fractures of the radius and in two of the four associated with fractures of the ulna. Neurolysis was sufficient in the other two cases (fig. 198). In all but one of the neurorrhaphies, the indication for repair was a neuroma in continuity. In the other case, the indication was a 2.2-cm. gap left after excision of damaged nerve tissue.

In the three cases, all median nerve injuries, in which the nerve was involved at the elbow, it was possible to perform the neurorrhaphy with the elbow in flexion, in the optimum position, though in one instance, ankylosis with extension contracture required preliminary arthroplasty with resection of bony fragments and scar tissue before the elbow could be flexed to 90°. In the other two cases, the head of the radius was excised because of severe comminution and displacement.

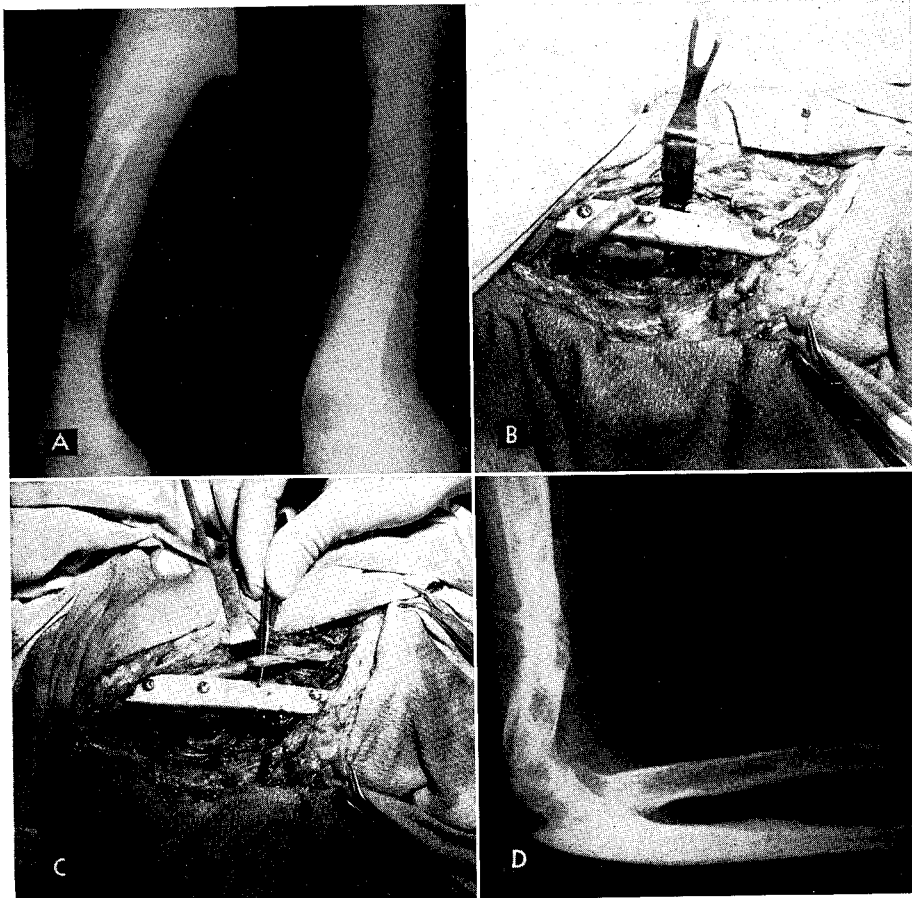

FIGURE 196.—Combined bone-nerve surgery in injury of humerus and radial nerve. A. Preoperative roentgenogram. B. Onlay bone graft in place and nerve ends prepared for suture. C. Rerouting of proximal nerve segment to avoid fixation in callus of healing fracture site. D. Postoperative roentgenogram. Note tantalum sutures.

In the two remaining cases, the dorsal interosseous nerve was sutured after resection of the synostosis of the radius and ulna; the mechanical functional result was good in each case, but in neither was there any return of function. The defect in the nerve after excision of the neuroma and of the damaged tissue, respectively, was 10 cm. and 5 cm.

The problem in combined injuries of the ulnar and median nerves and the bones of the forearm differed from the problem in combined bone-nerve injuries of the upper arm in that shortening of the bones of the forearm was not necessary for nerve repair; the advisability of shortening of the bones of the forearm is, as a matter of fact, always questionable.

The problem of timing also entered into the management of combined bone-nerve injuries in the forearm. As already pointed out, it was usually

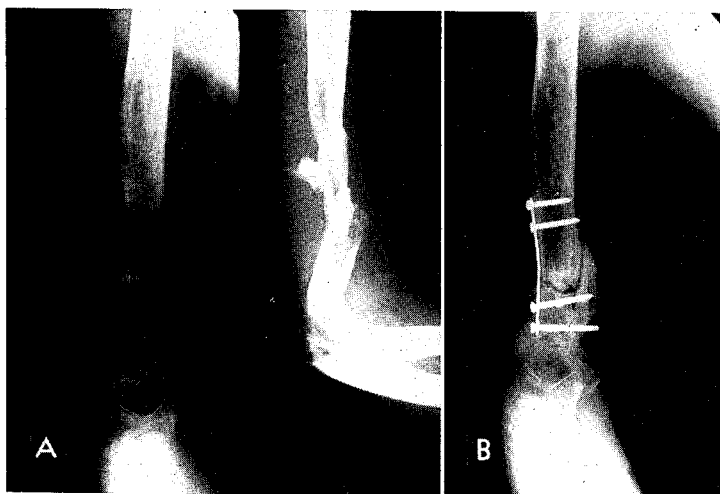

FIGURE 197.—Combined surgery in injury of humerus and radial nerve. A radial nerve defect 6 cm. long was found at operation approximately 7 months after injury by shell fragments. After isolation of the nerve and anterior transplantation, the bone was shortened 2.5 cm., and a bone plate was fixed with two Vitallium screws above and below the fracture. Neurorrhaphy was then performed with tantalum wire. Recovery was uneventful, and solid bony union ensued. A. Preoperative roentgenogram. B. Postoperative roentgenogram.

safe to repair injured nerves within 2 weeks after wound healing, but it was never safe to repair bones in less than 2 months. In the forearm, therefore, in which bone shortening was not done, it was often the practice to repair the nerve alone within 2 to 2½ months after wound healing and defer the necessary bone surgery until later. The only combined bone-nerve cases in this series were those in which healing had occurred sufficiently long before to make bone surgery safe at the nerve operation.

Femur and hip.—The sciatic nerve was paralyzed in four cases in association with compound comminuted fractures of the femur (fig. 199). Bone repair was accomplished by bone grafts in three cases, in one of which the graft was employed only as a reinforcement. In the fourth case, in which both a bone graft and plating were used, the femur was refractured when the neurosurgical procedure was undertaken.

Flexion of the knee and mobilization of the nerve made repair feasible in all four cases. Neurolysis was sufficient in one case. Neurorrhaphy was necessary in the other three; in these cases, the defect ranged from 2.5 to 3.5 cm. initially and from 4 to 7.5 cm. after the necessary resection of the damaged ends had been carried out. Early motion of the knee was instituted promptly after operation.

In 17 other cases in which the sciatic nerve was injured and the femur was also fractured, suspension traction and orthopedic care proved adequate without bone surgery, and only nerve repair was necessary.

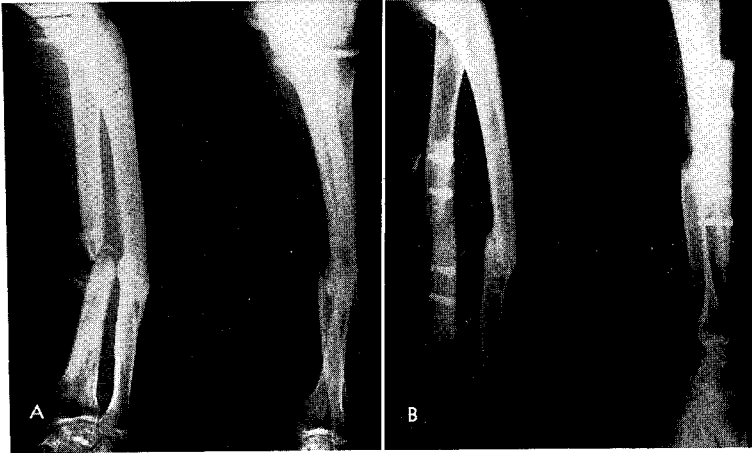

FIGURE 198.—Combined surgery in injury of radius, ulna, and median and ulnar nerves by machinegun bullet. The radial injury resulted in nonunion and a bone defect and the nerve injuries in paralysis. Neurolysis of both nerves was performed 2 months after injury; the application of a bone graft to the radius was deferred for 3 months because wound healing was not complete. Smooth recovery and good bony union ensued. Full return of median and ulnar nerve function was evident within 6 months after neurolysis. A. Preoperative roentgenogram. B. Postoperative roentgenogram.

In one instance of complete sciatic nerve paralysis, chronic posterior dislocation of the hip, associated with a fracture of the posterior lip of the acetabulum, had been present for almost 3 months when the patient entered Halloran General Hospital. Reduction of the dislocation by skeletal traction proved impossible. Reduction and arthroplasty were therefore performed, and a Smith-Petersen Vitallium cup was inserted. Neurosurgical exploration revealed no reason for the sciatic nerve paralysis other than nerve stretch secondary to the dislocation.

Knee.—In two instances, injury of the sciatic nerve was combined with severe ankylosis at the knee. Motion could not be obtained in spite of intensive physiotherapy and traction by the Thomas splint and Pierson attachment. Flexion to 90° was eventually possible after arthrotomy and separation of the scar tissue; in both instances, resection of the patella was also necessary because of the extensive lesions involving the articulating surface. After operation, the patients were placed in suspension traction, with removal pulleys and splints, and sufficient knee motion was thus obtained to permit repair of the sciatic nerve at later operations. Combined operation was not performed in any case in which nerve injury was associated with damage to the bones of the knee.

POSTOPERATIVE COMPLICATIONS

Complications occurred in only 2 of the 36 cases of bone-nerve injury managed by combined operation. In both instances, there had been a pre-

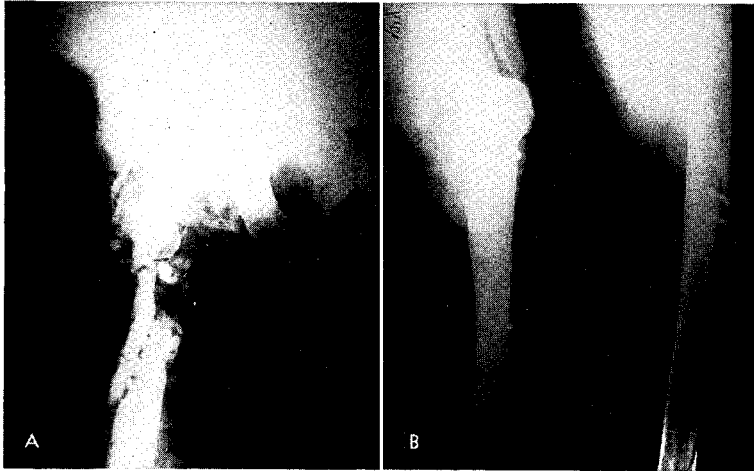

FIGURE 199.—Combined surgery in shell-fragment wound of femur and sciatic nerve. A bone graft was inserted 5 months after wounding, with a neurorrhaphy 7 weeks later. A 4-cm. defect of the sciatic nerve existed after resection of the ends and was compensated for by flexion of the knee and mobilization of the nerve. In later cases of this type (this being the first handled), the bone and nerve operations were performed simultaneously. Smooth recovery and solid bony union ensued. Ten months after operation, Tinel's sign had advanced 55 cm. from the level of nerve injury, and the Pollock test showed the tibialis anticus and gastrocnemius muscles in a regenerating phase. A. Preoperative roentgenogram. B. Postoperative roentgenogram.

operative infection, which was reactivated after operation. Both patients had had penicillin before operation and for 7 days afterward, and both had had a sterile 48-hour orthopedic preparation for surgery.

In the first case, infection was manifest by a temperature elevation on the 10th postoperative day. Two days later, the cast was removed and drainage instituted. The wound became quiescent under penicillin therapy, but drainage continued, and removal of the metal plate was necessary. Complete wound healing and solid bony union were then obtained, but regeneration of the radial nerve did not follow, and a tendon transplant was necessary to accomplish extension of the wrist and fingers.

In the second case, the temperature elevation occurred and a draining sinus developed on the fifth postoperative day, while the patient was still receiving penicillin. The acute infection rapidly subsided when adequate drainage was provided. At a later date, it was necessary to remove the two screws which had been used, as well as a portion of the bone graft which had separated by sequestration. Complete wound healing was obtained, as well as firm bony union. In this case, the infection did not interfere with nerve regeneration, and there was satisfactory return of function.

RESULTS

Table 11 presents the results of assessment of nerve function, with the time between the nerve operation and the last assessment, in the 36 cases of bone-nerve injury in which combined neurosurgery and orthopedic surgery were performed simultaneously at Halloran General Hospital. All of the muscles supplied by each nerve are not mentioned, only those being included which are checked routinely in postoperative nerve evaluations.

In 13 of the 15 cases of radial nerve injury in which neurorrhaphy was done in combination with orthopedic surgery, regeneration was satisfactory. In the other two cases, in which the nerve defect proved inoperable, surgery was not entirely futile, since, in each instance, reinforcing bone grafts were inserted through the incision made for exploration of the nerve.

Failure of union occurred in one case of supracondylar fracture of the humerus associated with radial nerve injury. The fractured ends separated either at the time of nerve suture or when the plaster cast was applied. A second bone graft went on to full bony union. The radial nerve, which had been transplanted anteriorly, was fortunately not separated, and the patient had a satisfactory advance of Tinel's sign, with return of function of the proximal muscles.

Satisfactory regeneration had also occurred or was in progress at the last examination in the seven cases of ulnar nerve injury in which neurorrhaphy was done in combination with orthopedic surgery. Similarly good results were obtained in the single neurorrhaphy done for median nerve injury, and in the two neurolyses done for ulnar nerve injury and the three done for median nerve injury in combination with orthopedic surgery; at the last examination, the distal muscles showed voluntary function in all of these cases.

The results were also satisfactory in the three neurorrhaphies and the one neurolysis performed for sciatic nerve injury in combination with internal fixation of the femur. It might be added that satisfactory nerve regeneration also occurred in the 17 other cases in which sciatic nerve surgery had to be deferred until 90° flexion of the knee could be obtained by orthopedic treatment.

CHAPTER XVII

Peripheral Nerve Injuries Complicated by Skin and Soft-Tissue Defects

Stanley E. Potter, M.D., and Edmund John Croce, M.D.

EVOLUTION OF POLICIES

By the time a neurosurgical center was organized at the Halloran General Hospital, Staten Island, N.Y., the problems inherent in combined bone-nerve injuries were fully recognized, and a subsection was created for their management. The value of the policy of segregation of these injuries was proved by their subsequent expeditious and successful management.

The management of nerve injuries associated with soft-tissue damage and loss of skin also presented special problems, which were promptly recognized, but the patient load in this category was not large enough to warrant the creation of a special subsection to handle them. Although there was never any doubt of the importance of cooperation between the neurosurgeon and the plastic surgeon, the plans originally adopted were not satisfactory. The transfer of neurosurgical patients to plastic centers for preliminary surgery meant postponement of the nerve repair, which, experience had shown, was always most satisfactory when it was performed early. On the other hand, if neurosurgery were performed first, a successful plastic repair might be compromised and the ultimate plastic result seriously jeopardized. Because complicated plastic surgery, especially surgery requiring tube construction, was best undertaken at a plastic surgery center, delayed nerve surgery was sometimes reluctantly accepted. In other cases, nerve repair was performed as the first procedure, with split-thickness skin grafts used as a temporary measure.

After all of these policies had been tested and had proved less than successful or entirely unsuccessful, the policy was adopted of combining nerve repair with the rotation of flaps or the construction of pedicle flaps or other plastic procedures as indicated. Nerve repair was thus possible at a desirably early period after wounding, and the patient was subjected to a single procedure. The prolongation of the operating time was not a major difficulty, since local anesthesia was employed in most nerve repairs and was also possible in the creation of smaller flaps.

ROUTINE OF MANAGEMENT

A preliminary survey of each patient was carried out jointly by the neurosurgeon and the plastic surgeon. The plastic surgeon determined the

type of plastic operation necessary, instructed the neurosurgeon in the pattern of scar removal, and advised concerning the optimum placing of the neurosurgical incision at the angles of the skin defect. A consideration of the possible posturing of the extremity required in nerve repair was always part of the preliminary survey.

The neurosurgeon initiated surgery, under local anesthesia. The cutaneous scar or the split-thickness skin graft which had been employed in closure was excised, and the incision was extended to provide adequate exposure. The nerve was then repaired according to the technique necessary in the special case. It was desirable, when possible, to transplant the suture site from the area in which grafting was to be undertaken. If this was not feasible, the suture site was placed in a fresh muscle plane. Tantalum cuffs were not employed in cases in which plastic surgery and nerve surgery were combined. If, however, the suture site could not be transplanted and had to be left in a scarred bed at the site of the graft, a protective sleeve was sometimes employed. It was so placed that it did not underlie the suture line at the edge of the graft. Plastic repair was then proceeded with.

SPECIAL TECHNIQUES

Since skin grafts often became ischemic when they were mobilized in operations for restoration of nerve function, the prophylactic policy was adopted, as already indicated, of excising these areas of doubtful vitality after the neurosurgical procedure had been completed. If this precaution was omitted, there was always a chance that the nerve repair would be endangered and that secondary plastic procedures would also be required.

The pedicle flap used to cover the skin defect was usually raised from the trunk when the wound was in the upper extremity. Sometimes, however, the donor site was on the chest wall, because suture of the nerve defect required immobilization of the extremity in varying degrees of flexion. When circumstances permitted, the anterolateral aspect of the abdomen was most desirable because the skin is loose in this area and subcutaneous tissue is more abundant. For these reasons, the defect which remained after the graft had been raised could often be closed primarily without distortion of the regional topography.

A defect in one lower extremity was covered by a pedicle graft raised from the other, though the optimum donor site could sometimes not be employed because the affected limb had to be immobilized in flexion. When the posterior aspect of the upper or middle thigh was employed, moderate postoperative discomfort was present for several days, but it was regarded as justified; the use of this area as a donor site made it possible to close the defect primarily, as in donor sites in the trunk, while the use of a similar area on the calf required a split-thickness skin graft to effect closure.

The recipient defect was accurately measured, and a pattern was made of it upon gauze with methylene blue. The outline of the pedicle graft was then drawn with methylene blue, with the aid of the pattern. In determining the length of the pedicle, allowance was made for the distance between the abdomen and the base of the defect if juxtaposition of these areas was not possible. The flap was raised to face the flexor or the extensor surface of the extremity, depending upon the position of the defect, so that the base of the defect and the abdominal wall would be as close as possible to each other. The full-thickness graft was raised at the level of the deep fascia. The size of the graft was often considerable; the largest in the cases managed at Halloran General Hospital measured 15 by 10 cm.

The donor site was closed primarily whenever possible; this was usually feasible. To facilitate closure, an incision was made on either side of, and in line with, the base of the pedicle, and triangular flaps were raised and were rotated toward each other. After transection of the pedicle, revision of the wound of the donor area left a neat T-shaped scar. Silk sutures were used throughout.

POSTOPERATIVE MANAGEMENT

It was the practice to transect the base of the pedicle in two stages, or sometimes in three stages, over a period of 15 to 21 days, depending upon the width of the pedicle, the size of the graft, and the circulatory status of its apex. A preliminary test, by occlusion of the base with a rubber-covered intestinal clamp, served as a useful guide in determining the vascular independence of the graft. A proper amount of pressure was applied to the surface of the graft by means of a circular elastic bandage over mechanics' waste.

The limb was immobilized in plaster of paris until the graft was freed from its source.

CONCLUSIONS

The seven case reports related in the legends attached to the illustrations in this chapter (figs. 200 through 206) are typical of the cases of combined nerve and soft-tissue injuries treated at Halloran General Hospital and at other neurosurgical centers in the Zone of Interior. From this total experience, the following general conclusions are believed to be warranted:

1. Peripheral nerve injuries accompanied by soft-tissue wounds which have been allowed to heal secondarily or have been covered by split-thickness skin grafts are best managed by a combined procedure. Definitive nerve surgery can thus be performed at a desirably early period after wounding, while the cooperation of the plastic surgeon at operation means that the ultimate cosmetic result will not be jeopardized by the neurosurgery necessary.

2. Surgical defects resulting from removal of scar tissue or from inadequate split-thickness skin grafts should be covered with full-thickness

skin grafts from pedicle grafts mobilized concomitantly with the neurosurgical procedure.

3. For defects of the upper extremity, the abdominal or chest wall may serve as the donor site, depending upon the necessities of the special case. For defects of the lower extremity, the surface of the opposite thigh may be used. The location of the donor site is often limited by the posturing necessitated by the neurosurgical repair.

4. In most instances the defect created by raising the pedicle graft may be closed primarily, by creation of sliding flaps.

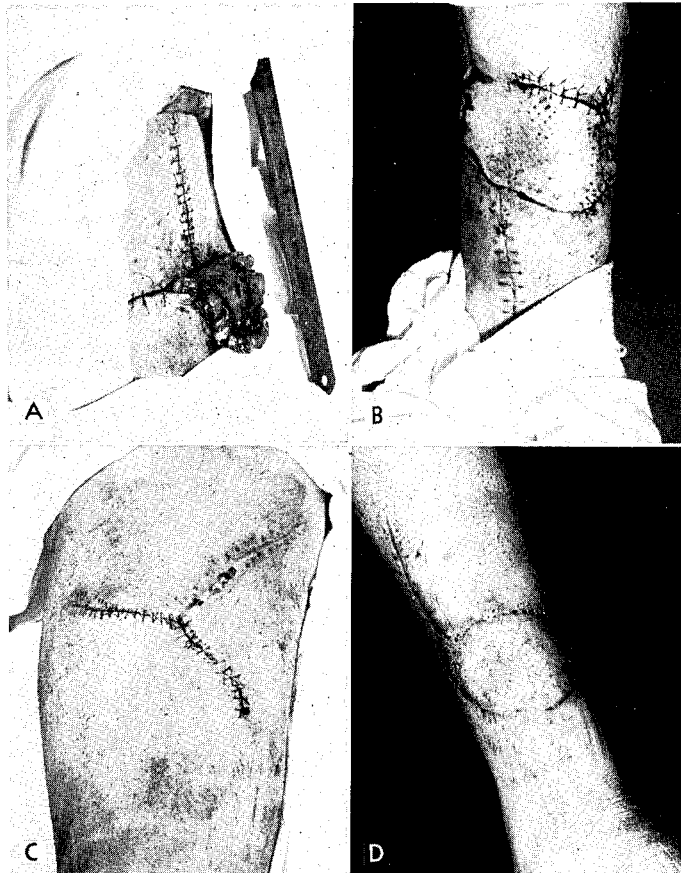

FIGURE 200.—Repair of incomplete injury of right posterior tibial nerve, with avulsion of skin and soft tissues of lower third of right leg due to flak injury; wound healed by granulation while patient was prisoner of war. Three-stage reparative procedure, including (1) neurolysis of posterior tibial nerve and pedicle flap from posteromedial aspect of left thigh $3\frac{1}{2}$ months after wounding; (2) partial section of pedicle 10 days later; and (3) complete transection of pedicle, with revision of donor site 7 days later. A. Preparation of pedicle. Note T-shaped closure of defect. B. Recipient site following division and suture of base of pedicle. C. Donor site after division and suture of base of pedicle. D. Medial aspect of right leg showing fully healed full-thickness graft.



FIGURE 201.—Repair of incomplete injury of right posterior tibial and superficial peroneal nerves, with avulsion of skin and soft tissues of lower third of right leg and compound comminuted fracture of tibia, due to mortar shell fragments. Split-thickness skin graft applied to defect 1 month after injury. Three-stage reparative procedure, including (1) neurolysis of posterior tibial nerve and pedicle flap from posteromedial aspect of left thigh 10 months after injury; (2) partial section of pedicle 7 days later; and (3) complete transection of pedicle, with revision of donor site, 10 days later. A. Medial aspect of right ankle, showing split-thickness graft overlying scar tissue. B. Operative site immediately following excision of scar and neurolysis. C. Medial aspect of right ankle showing fully healed full-thickness graft.

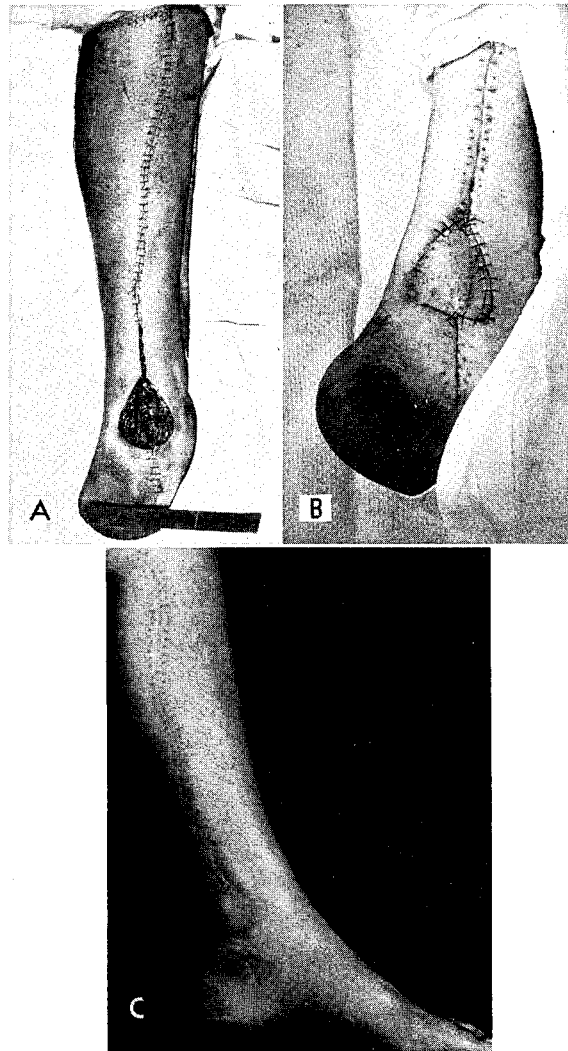

FIGURE 202.—Repair of complete injury of left posterior tibial nerve, with loss of skin and soft tissues of extremity and laceration of posterior tibial artery and vein, due to shell fragments. Previous surgery included (1) approximation of nerve ends with black silk 24 hours after injury and (2) split-thickness graft to wound site 17 days later. Three-stage reparative procedure, including (1) left posterior tibial nerve repair and pedicle graft from posteromedial aspect of right thigh 8½ months after wounding; (2) partial section of pedicle 10 days later; and (3) complete section of pedicle, with revision of donor site, 7 days later. A. Skin defect after excision of split-thickness graft and scar tissue. The neurorrhaphy has been completed and the sutured nerve lies exposed. B. Recipient site after division and suture of base of pedicle. C. Medial aspect of left ankle showing healed full-thickness graft.

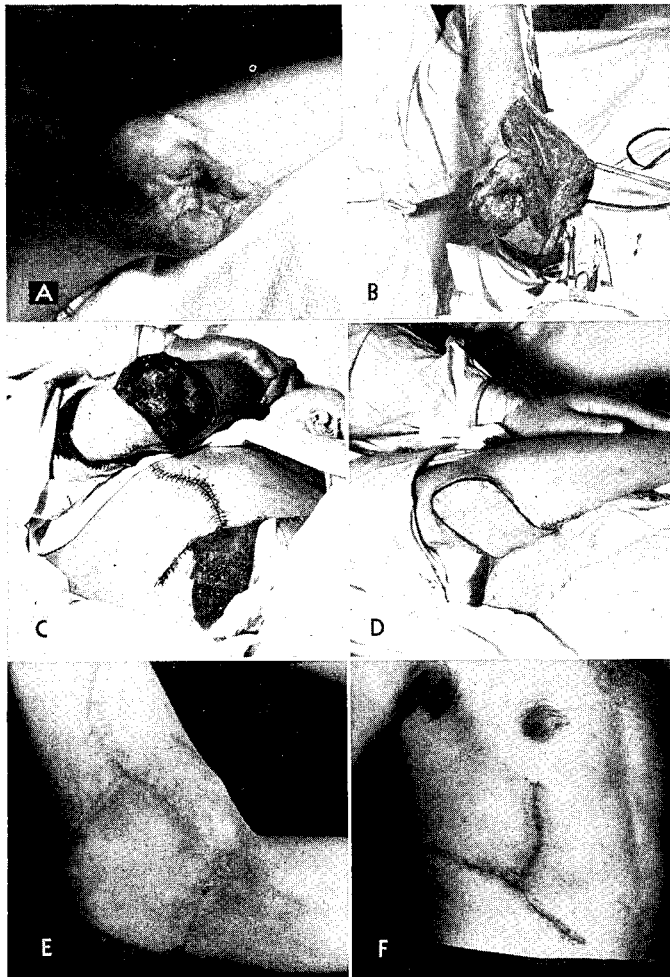

FIGURE 203.—Repair of incomplete injury of right ulnar nerve, with massive skin and soft-tissue loss, and compound comminuted fracture of distal end of humerus, due to shell fragments. Split-thickness graft to right elbow 3 weeks after injury. Three-stage reparative procedure including (1) neurolysis and transplantation of right ulnar nerve, with pedicle graft from abdomen 10½ months after injury; (2) partial section of pedicle 9 days later; and (3) complete transection of pedicle, with revision of donor site, 8 days later. A. Right elbow showing extensive scar, in large part immediately overlying bony structure; a split-thickness graft has been utilized to secure early healing. B. Operative site following excision of scar, neurolysis, and transplantation of ulnar nerve. C. Closure of defect at donor site on anterolateral aspect of abdomen. D. Pedicle graft sutured to skin defect after excision of scar and split-thickness graft. The ulnar nerve has been transplanted anterior to the area of the pedicle graft. E. Posteromedial aspect of right elbow showing healed full-thickness graft. The graft healed without infection, but there was a spotty area of superficial necrosis in the distal third; this area cleared up promptly, without in any way endangering the purpose of the graft. F. Healed donor site on trunk.



FIGURE 204.—Repair of incomplete injury of right median nerve, with skin and soft-tissue loss, and compound comminuted fracture of radius and ulna, due to small arms fire. Wounds healed by granulation after debridement. Three-stage reparative procedure including (1) neurolysis of right median nerve, with pedicle flap from abdomen, 6 months after injury; (2) partial section of pedicle 7 days later; and (3) complete transection of pedicle, with revision of donor site, 2 weeks later. Improvement in sensory and motor function was apparent 19 days after operation. A. Right forearm, showing extensive adherent scar following healing of wound by secondary intention. B. Pedicle flap from abdomen. C. Right forearm before partial section of pedicle flap. D. Volar surface of right forearm showing healed full-thickness graft.

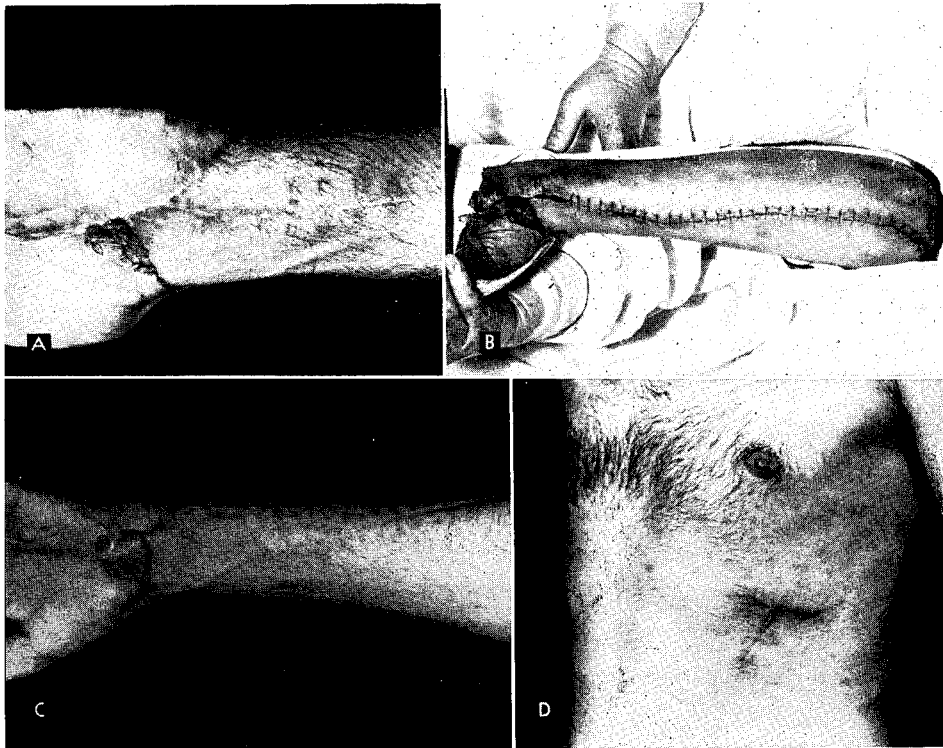

FIGURE 205.—Repair of incomplete injury of left ulnar nerve, with avulsion of skin and soft tissues, due to small arms fire. Secondary closure and split-thickness graft 9 days after injury; exploration of ulnar nerve, without suture, 5½ months later. Three-stage reparative procedure including (1) neurorrhaphy and transplantation of left ulnar nerve, with pedicle flap from left costal margin, 7 months after injury; (2) partial section of pedicle 10 days later; and (3) complete transection of pedicle, with revision of donor site, 7 days later. A. Left wrist showing skin and soft-tissue defect. B. Skin defect after excision of split-thickness graft and scar tissue after completion of neurorrhaphy. C. Healed full-thickness graft of left wrist. Superficial necrosis of a small area did not interfere with healing. D. Healed donor site on trunk.

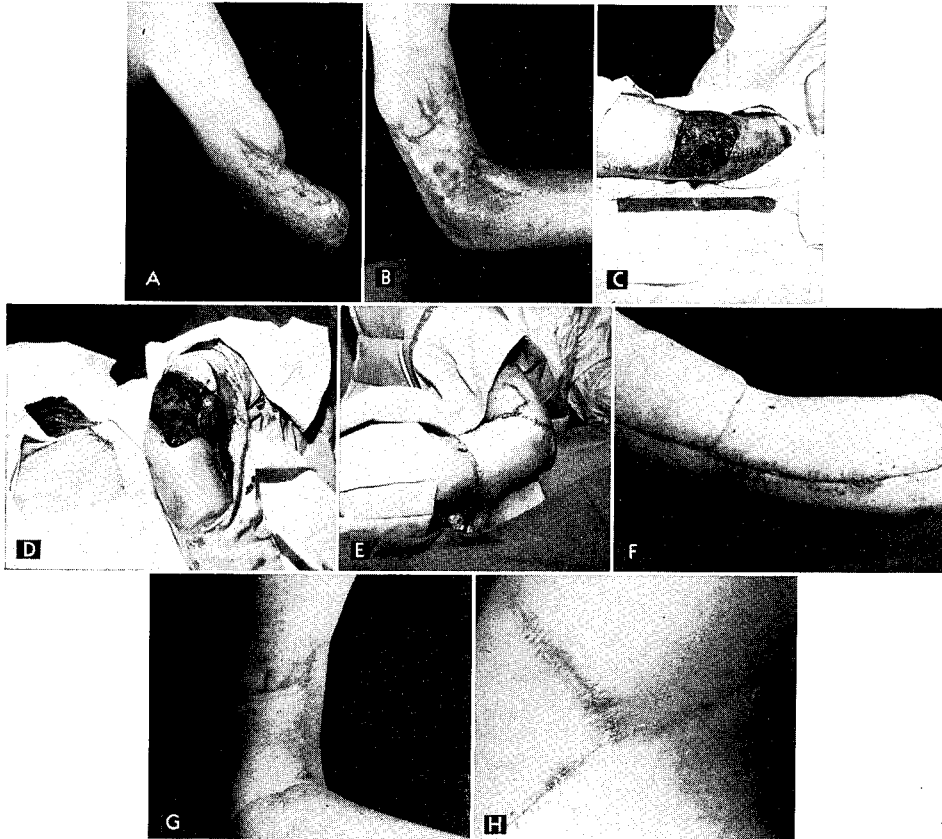

FIGURE 206.—Repair of complete injury of right radial nerve, with avulsion of skin and soft tissues of lateral aspect of lower third of arm, and compound comminuted fracture of humerus with loss of bone substance, due to shell fragments. Split-thickness graft to skin and soft-tissue defect 2 months after injury. Four-stage reparative procedure, including (1) exploration of radial nerve, with reduction of 8.5-cm. defect to 4 cm. by mobilization, with pedicle flap from abdominal wall 6 months after injury; (2 and 3) partial section of pedicle 7 days, and again 14 days, later; and (4) complete transection of pedicle, with revision of donor site, 8 days later. A. Right arm and elbow showing extensive deformity after loss of soft tissue. B. Lateral aspect of right arm and elbow showing extensive adherent scar overlying bone; split-thickness graft used to secure early healing. C. Skin and soft-tissue defect after nerve exploration. D. Pedicle flap from anterolateral abdominal wall. E. Flap sutured into defect. F and G. Postoperative result. A minor wound infection along the proximal suture line of the graft did not interfere with healing. Note removal of scar tissue. H. Healed donor site.

This patient was later submitted to end-to-end suture of the radial nerve without compromise of the graft. Bone shortening, which had been contemplated to permit bridging of the nerve gap, did not prove necessary because of the gradual stretch of the nerve by elbow extension after skin grafting.

CHAPTER XVIII

Peripheral Nerve-Vascular Injuries

Barnes Woodhall, M.D.

INCIDENCE

Although complete statistics are not yet available, the indications are that the incidence of combined vascular and peripheral nerve injuries in World War II will considerably exceed their incidence in any previous war. Basic data secured from the Peripheral Nerve Registry showed that a major vascular injury was present in 12.9 percent of peripheral nerve injuries in which division of the nerve occurred and in which these data were stated. The experience of World War II, like that of World War I, indicated that neural complications were much more frequent in aneurysms of the upper extremity than in those of the lower. The registry analysis showed 2.6 percent of combined injuries of the sciatic nerve and the regional vascular supply but provided no other data on regional injuries.¹

Combined vascular-nerve injuries are always fairly frequent in warfare for the anatomic reason that, with very few exceptions, all large blood vessels are accompanied in their course by peripheral nerve tissue. This is particularly true of the neck, where the great vessels lie in close proximity to important cranial and cervical nerves, and is also true of the brachial, femoral, and popliteal regions.

There were two reasons for the greater incidence of these combined injuries in World War II than in previous wars. The first was the excellence of the initial medical care, including improved methods for control of shock and infection, which kept many casualties alive who would formerly have died of their injuries. The second reason is that, in addition to the usual wounds caused by machinegun fire, rifle bullets, and shell fragments, numerous multiple injuries were caused by the fragmentation of landmines,

¹ In the followup studies on peripheral nerve regeneration published as a Veterans' Administration medical monograph in 1956 (p. 230), it was found that arterial injury was associated with peripheral nerve injury in 32.0 percent of median nerve injuries, 23.4 percent of ulnar nerve injuries, 15.1 percent of radial nerve injuries, 1.5 percent of peroneal nerve injuries, 3.9 percent of tibial nerve injuries, and 3.0 percent each of sciatic-peroneal and sciatic-tibial injuries. In the upper extremity, arterial injuries were associated with nerve injuries in 24.4 percent of all cases; the largest proportion, 42.4 percent, was in injuries of the shoulder and the upper third of the arm, and the next largest, 27.8 percent, in injuries of the middle third of the arm, with injuries of the middle third of the forearm showing almost the same proportion, 26.8 percent. The smallest proportion, 12.3 percent, was in injuries about the elbow. In the lower extremity, arterial injuries were associated with nerve injuries in only 2.8 percent of all cases, the largest proportions, 6.3 percent and 6.1 percent, respectively, being about the ankle and in the middle third of the leg. No injuries of this sort were reported in the lower third of the leg or in the foot.

grenades, and aerial bombs. When as many as 50 small individual wounds might be scattered over the body from the fragmentation of a landmine or a grenade, the chances of a combined vascular-nerve injury were naturally greatly increased.

DIAGNOSTIC CONSIDERATIONS

No very long military experience was necessary to show that diagnoses made under battle conditions could not always be accepted at their face value. Errors were particularly likely to occur in combined vascular-nerve injuries, and, because of the conditions of military care in combat areas, they might be carried by a wounded soldier for some time. These facts by no means imply that initial management had been incorrect. On the contrary, in the inception of any vascular injury, such as division of a major vessel, the immediate care, quite correctly, was always directed toward the control of hemorrhage. Surgeons working in frontline hospitals had neither the time nor the facilities for elaborate investigation of individual patients when the nature of their injuries seemed obvious.

In some vascular injuries, hemorrhage was slight, even though a major vessel was involved, and bleeding could be controlled by simple measures or was held in check by the natural pressure of the soft tissues. In this type of injury, a pulsating hematoma or a false aneurysm might result. In still other instances, vascular lesions developed slowly to the point of recognition. An arteriovenous fistula, for example, though it was undoubtedly present from the onset of injury, might not show characteristic signs until sometime later, after edema and hemorrhage into the tissues had been absorbed.

As a general rule, the formidable nature of the vascular lesion at first overshadowed the less dangerous but often more incapacitating neural defect. In some instances, however, nerve lesions which produced motor and sensory paralysis of the upper and lower extremities were so obvious, because of their disabling consequences, that vascular injuries, at least in their early stages, might be overlooked. It was therefore of the greatest importance that patients with either nerve or vascular injuries be subjected to exhaustive investigation, including auscultation, in general hospitals distant from the battlefield or in Zone of Interior hospitals, and that the examination be conducted without prejudice by the previous diagnosis.

The chronology of the symptoms and signs was often a matter of considerable diagnostic importance, and the patient's history was therefore carefully reviewed. Excessive hemorrhage, repeated blood transfusions, and the cold, gray pallor of an extremity in which an acute vascular occlusion had occurred were unlikely to be forgotten by a patient who had retained consciousness after injury. Similarly, the history often suggested the extent of the damage to nervous tissue. Even during the acute stage of injury, a conscious patient was usually immediately cognizant of sensory and motor loss. Paralysis of a peripheral nerve which became evident at the time of

wounding might indicate severe trauma or even section of the involved nerve. When it became apparent at a later date in a patient who also had an aneurysm, the assumption that it was due to pressure was clearly justified, and the observation was of both diagnostic and prognostic importance.

Vascular centers and neurosurgical centers were generally established in the same hospitals in the Zone of Interior, and professional association was close. Unfortunately, however, the potentialities of combined vascular-nerve injuries for joint management and investigation were not realized as fully as they might have been in World War II.

INJURIES OF THE NECK

For anatomic reasons, as already noted, combined vascular-nerve injuries were frequent in the neck. In the jugular foramen, the glossopharyngeal, vagus, and spinal accessory nerves lie in that order between the inferior petrosal sinus anteriorly and the internal jugular vein posteriorly. The internal jugular vein, at its exit from the jugular foramen, lies external to the nerves, while the carotid artery, with its accompanying sympathetic plexus, lies closely anterior and medial to them. The hypoglossal nerve, which leaves the skull through the adjacent anterior condyloid foramen, is also in close proximity to them. All four nerves remain in close approximation to each other in their more peripheral courses, to a point slightly below the tip of the mastoid, in the so-called retroparotid space. The fifth and seventh nerves are more laterally placed, in the coronal plane of the head.

As Pollock and Davis² stated, the number of possible neurologic syndromes caused by wounds of the neck is limited only by the possible combinations of complete or incomplete paralyzes of these several cranial nerves and the descriptive ability of the various observers who write of them. The syndrome described by Avellis,³ for instance, long before World War I, consists of unilateral paralysis of the soft palate and the larynx and is caused by a lesion of the vagus and the internal branch of the spinal accessory nerve. The syndrome of Schmidt (cited by Pollock and Davis) simply adds involvement of the external branch of the spinal accessory nerve to the injuries of the vagus nerve and the internal branch of the spinal accessory nerve. The syndrome of Jackson⁴ adds involvement of the hypoglossal nerve to these lesions.

During the course of World War I and in the years following, a number of other observers added significant contributions to the literature of war

² Pollock, Lewis J., and Davis, Loyal: *Peripheral Nerve Injuries*. Hoeber's Surgical Monographs. New York: Paul B. Hoeber, Inc., 1933.

³ Avellis, G.: *Klinische Beiträge zur halbseitigen Kehlkopflähmung*. Berl. Klinik 40: 1-26, 1891.

⁴ Jackson, J. H.: *Paralysis of Tongue, Palate and Vocal Cord*. Lancet 1: 689-690, 10 Apr. 1886.

injuries involving these neural structures.⁵ The nomenclature which they employed was descriptive and denoted either the neurologic distribution of the affected structures or the anatomic location of the causative wound. Among these terms were syndrome of the posterior lacerated foramen; glossolaryngoscapulopharyngeal hemiplegia; complete syndrome of the last four cranial nerves; and syndrome of the posterior retroparotid space. Whatever the syndromes were termed, the resulting neurologic dysfunction depended upon the close anatomic continuity of the last four cranial nerves in the early part of their extracranial courses.

Reports of combined injuries to the jugular vein and carotid artery in association with injuries to the last four cranial nerves are extremely uncommon in the literature of World War I, although, for the anatomic reasons just mentioned, such a combination must have occurred fairly frequently. Among the reports was Heyrovsky's description of the involvement of the last four cranial nerves in association with a spurious aneurysm of the vertebral artery. Aneurysmorrhaphy corrected the vascular lesion but had no effect on the neural lesion.

In World War II, the number of combined vascular-cranial nerve injuries observed at the vascular centers in the Zone of Interior was also surprisingly small, although the congregation of vascular injuries at these centers provided far more favorable circumstances for their recognition than existed in World War I. Such injuries, for anatomic reasons, must be fairly frequent, and their apparent infrequency is open to three possible explanations, as follows:

1. These cranial nerves may be injured without concomitant vascular injury, as observed by Vernet.
2. Vascular injuries may occur in association with the neural injuries but may heal spontaneously.
3. The vascular injury may be so formidable that, even with modern methods of controlling shock (methods which did not exist in World War I), they are promptly fatal.

The vascular lesions observed in combined vascular-cranial nerve injuries in Zone of Interior vascular centers included arteriovenous aneurysms, false aneurysms, and cicatricial occlusion. The extent and duration of the vascular injury often bore no relation to the extent and duration of the

⁵ (1) Barbé, A.: Le Syndrome nerveux de l'espace sous mastoïdien. *Progr. méd.*, Paris, 34: 281-282, 19 July 1919. (2) Collet: Sur un nouveau syndrome paralytique pharyngo-laryngé par blessure de guerre. Hémiplégié glosso-laryngo-scapulo-pharyngée. *Rev. neurol.* 22: 982-984, 1915. (3) Körner, Von O.: Ueber Lähmungen der Nervi vagus, accessorius Willisii, hypoglossus und sympathicus durch Fernschädigung bei Halsschüssen. *München. med. Wchnschr.* 63: 1429-1430, 3 Oct. 1916. (4) Pollock, L. J.: Extracranial Injuries of Multiple Cranial Nerves. *Arch. Neurol. & Psychiat.* 4: 517-528, November 1920. (5) Sicard, J. A.: Syndrome du carrefour condylo-déchiré postérieur (type pur de paralysie des quatre derniers nerfs craniens). *Bull. et mém. Soc. méd. d. hôp. de Paris* 41: 317-327, 16 Feb. 1917. (6) Vernet, M.: Syndrome du trou déchiré postérieur (paralysie des nerfs glosso-pharyngien-pneumogastrique-spinal). *Rev. neurol.* 25: 117-148, November-December 1918. (7) Villaret, M.: Le Syndrome de l'espace rétro-parotidien postérieur. *Paris méd.* 23: 430-431, 1917. (8) Heyrovsky, J.: Nach Schussverletzung entstandenes Aneurysma spurium der A. vertebralis operativ behandelt. *Med. Klin.* 11: 22, 3 Jan. 1915.

neural injury. In other instances, the aneurysmal mass either caused the neural lesion by its pressure or influenced it adversely, though it did not necessarily follow that repair of the vascular lesion would favorably influence the neural lesion.

As the following case histories show, if vascular injuries were promptly and correctly controlled at the time of wounding, the casualty's life could be spared and some degree of rehabilitation could be accomplished even if there was no improvement in the neurologic status after correction of the vascular lesion.

Case Histories

Case 1.—This patient was wounded in the left malar region 10 November 1942, with a French .44-caliber revolver bullet, which struck him at close range, traversed the face and lateral aspect of the neck, and became embedded in the soft tissues of the left occipitomastoid region. He staggered back under the impact of the bullet but did not lose consciousness. He immediately noticed loss of sensation in the mouth and lower left side of the face. His voice became hoarse, and he was unable to lift the left arm fully from the side. The tissues of the neck swelled considerably, but there was no extensive external hemorrhage. A few days afterward, he became cognizant of a loud buzzing in the left ear, and, on occasion, his pulse rate became very rapid. The bullet was removed from the left occipital region 22 December 1942, and the left common carotid artery was ligated 22 February 1943. Neither operation produced any change in his symptoms.

When the patient was admitted to Ashford General Hospital, White Sulphur Springs, W. Va., 2 months after the second operation, examination revealed the following findings: A small scar over the left malar region denoted the wound of entry and a short scar 4 cm. mesial to the tip of the left mastoid the operative wound. The tissues in this region appeared full in comparison with those on the right. Palpation revealed a deeply situated, pulsating mass, with a distinct systolic thrill. Auscultation revealed a continuous bruit, accentuated in systole, with maximal intensity over the occiput; it could be obliterated by deep pressure over the sternomastoid muscle. Arterial pulsation was absent over the left common carotid artery, the site of the earlier ligation.

The impression was that the lesion was an arteriovenous fistula of the cirroid type, probably involving the occipital artery and vein deep to the muscles and posterior to the mastoid process, but possible involvement of the vertebral artery with the accompanying veins in this region was also considered.

Significant findings revealed by neurologic examination were as follows: The pupils were of equal size, and there was no enophthalmos. Analgesia and anesthesia were present over the third branch of the left fifth nerve. There was loss of taste over the anterior two-thirds of the left side of the tongue, which protruded to the left and was atrophic and furrowed on this side (fig. 207). The soft palate was pulled to the right upon phonation and the gag reflex was absent on the left side. The voice was hoarse, and laryngoscopy disclosed a left abduction palsy. The left arm could not be abducted beyond 90°. The left sternomastoid muscle was atrophied. The lower third of the trapezius muscle was also atrophied, and the superior third was incompletely paralyzed. The neurologic diagnosis was involvement of the fifth cranial nerve and of the special visceral afferent (taste) fibers of the 7th nerve and the 9th, 10th, 11th, and 12th cranial nerves (similar to the syndromes reported by Collet, Vernet, and Sicard), with the addition of the fifth and seventh nerve lesions.

Operation was performed 15 June 1943. A semicircular incision, beginning over the left mastoid muscle, was carried upward over the base of the skull to the midline. The

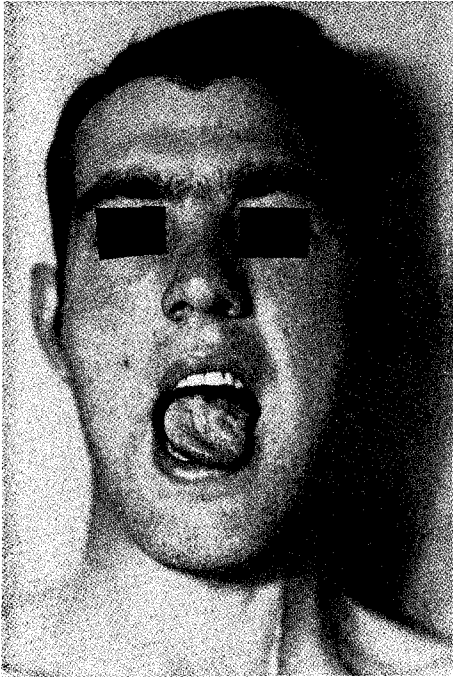

FIGURE 207.—Paralysis of left hypoglossal nerve following gunshot wound of face. Tongue is atrophied and furrowed on the left and protrudes to this side. An arteriovenous aneurysm of the occipital vessels resulted from the same injury.



FIGURE 208.—Left seventh nerve paresis. Note wound of entry on left lateral aspect of nose, with development of arteriovenous aneurysm of cavernous sinus and internal carotid artery.

deep muscles were cut and retracted caudally. An arteriovenous aneurysm of the occipital vessels was then seen and felt at the base of the skull. Ligation of the external carotid artery had little if any effect on it. The aneurysm was excised by ligating and cutting the numerous arteries and veins seen to communicate with vessels entering the skull. The considerable bleeding encountered was controlled by coagulation and by the use of fine silk sutures. The bruit and thrill were no longer present at the conclusion of the operation.

Two weeks later, after a friendly wrestling match, the wound opened, and a severe secondary hemorrhage occurred. It was controlled by packing and by hemostats, which were left in place. The vertebral artery was then ligated. This procedure apparently controlled the bleeding at the source, since there was no further hemorrhage when the packs and clamps were removed. The wound healed uneventfully, and the bruit and thrill did not return, but there was no change in the neurologic findings when the patient was discharged 3 months later, and also no change upon review examination 3 months after discharge.

Case 2.—This soldier was injured 31 March 1943 by aerial bomb fragments which struck the left frontal region of the scalp, the left side of the neck, and the left thigh. He was unconscious for 2 hours. Severe hemorrhage persisted from the neck wound, and two plasma transfusions were given during the first 24 hours after injury.

Forty-eight hours after wounding, the wound in the neck was explored, and foreign bodies were removed. At this time, the patient was unable to talk, move the left side of his face, or shrug the left shoulder. He also had loss of feeling over the lower third of the left side of the face. He had some difficulty swallowing fluids.

Three weeks after the injury, the aphonia cleared, and his voice became progressively less hoarse. Both facial and shoulder movements improved slowly but steadily. From this period in his convalescence until his admission to Ashford General Hospital on 10 May 1943, he noticed an intermittent singing noise in the left ear.

Examination revealed a small, stellate, puckered scar below, and anterior to, the tip of the left mastoid. Palpation over the scar and in the anterosuperior cervical triangle disclosed a small, tubular, expansile mass. Auscultation over the mass revealed the presence of a harsh, continuous bruit, accentuated in systole, which could be obliterated by compression of the common carotid artery.

Neurologic findings included an apparent enophthalmos on the left, moderate weakness of the musculature about the left angle of the mouth, and hoarseness, with an abduction paralysis of the left vocal cord. The tongue was atrophic and protruded to the left. There was an area of hypalgesia and hypesthesia corresponding to the anterior fibers of the second cervical nerve. Taste perception was normal. The superior third of the left trapezius muscle was atrophic; there was weakness of shoulder elevation but normal abduction of the left arm.

The neurologic diagnosis was involvement of the 7th, 10th, 11th, and 12th cranial nerves and the 2d cervical nerve. With the exception of the seventh nerve disturbance, this case was similar to the case just recorded; the more inferiorly and laterally placed site of injury in this instance explained the lack of involvement of the glossopharyngeal nerve.

Surgical exploration of the expansile mass in the cervical region disclosed a cicatricial, incomplete occlusion of the common carotid artery with proximal dilatation of the vessel. The neurologic disturbance, with the exception of the abduction paralysis of the left vocal cord, improved steadily until the patient was discharged 3 months later.

In this case, the release of scar tissue about the carotid artery led to complete disappearance of the bruit and thrill, a finding worthy of note, since scar tissue contracting about a vessel may apparently produce the cardinal physical findings of an arteriovenous fistula.

Case 3.—This soldier was injured 3 December 1942 by fragments from a 20-mm. shell which struck the left mastoid region and left shoulder. The mastoid wound bled profusely for a few seconds; then hemorrhage ceased spontaneously. Three days later, this wound was explored, and a foreign body was removed.

On the following day, the patient noted a buzzing sound in the left ear and a swelling below the wound. For the first time, he complained of moderately severe generalized headache. There was weakness in the muscles of the lower half of the left side of the face, and his voice was hoarse. Solid food was tolerated without difficulty, but choking followed the ingestion of fluids. When he became ambulatory, he realized that he could not abduct the left arm beyond 90°.

On 3 April 1943, the left common carotid artery and left internal jugular vein were ligated. On 11 June 1943, the arteriovenous aneurysm involving these vessels was resected. Convalescence was without untoward incident.

Examination 9 July revealed a narrowing of the left palpebral fissure, enophthalmos, some decrease in intraocular tension as compared to the right (normal) side, loss of the ciliospinal reflex, and loss of sweating over the left side of the face. There was no change in sensation over the domain of the fifth cranial nerve. A contracture of some muscle fibers at the angle of the mouth caused inversion of this structure. There was weakness of the risorius and triangularis and of the lower fibers of the orbicularis. There was slight loss of the normal palatal arch on the left, and the soft palate pulled to the right

upon phonation. The voice was hoarse, and laryngoscopy revealed an abduction paralysis of the left vocal cord. The left sternomastoid muscle was functionless, and the left arm could not be abducted beyond 90°.

Examination at Ashford General Hospital 30 August 1943 revealed the following findings: The site of the operative procedure showed nothing abnormal, and there was no evidence of recurrence of the arteriovenous aneurysm. The pupils were equal and reacted to light stimulation and upon accommodation. There was intermittent conjunctival injection on the left. Vision in the right eye was 20/20; in the left eye, it was reduced to hand movements, with fingers recognized in the temporal quadrants. The optic nerve head of the right eye was normal. The left neuroretinal outline was clear, but the temporal half of the disk was pale. Adjacent to the temporal margin were two or three hyaline deposits, and similar deposits were noted nearer the macula. An area just above the disk was pale. The changes in the left fundus suggested an earlier papilledema with subsequent atrophy.

The neurologic diagnosis at this time was incomplete involvement of the cervical sympathetic chain and the 7th, 9th, 10th, 11th, and 12th cranial nerves. All components of the neurologic picture had improved considerably over the previous examination except those involving the 10th and 11th cranial nerves.

From the oversea clinical record, it was clear that this patient had had bilateral papilledema of three diopters before the original operation. This would suggest an increase in pressure in the venous circulation of the brain. Such a course is not incompatible with what is known of the physiology of an arteriovenous fistula, in which arterial blood enters the venous system at an increased pressure.

The syndrome in this case resembles that described by Villaret. Among six gunshot wounds of the last four cranial nerves described by Vernet is a case identical with this case; the postoperative course, unfortunately, is not described.

Case 4.—This officer was struck by a .30-caliber bullet 12 December 1942. The missile entered 1 cm. mesial to the inner canthus of the left eye and made its exit beneath the left mastoid region. He became unconscious at once and remained so for 24 hours. He was confused and drowsy for the next 4 days. Debridement was carried out on the day of injury, and sequestrectomy of a portion of the condyloid process of the mandible was done 10 days later.

Soon after injury, the patient was aware of numbness along the lower half of the left side of the face, weakness of the left facial musculature, and an inability to abduct the left arm above 90°. From the time of adequate orientation, he had noted a protrusion of the left eyeball, which had never diminished in size. Occasionally, he reported hearing a "roaring sound like the ocean" in his left ear.

The striking feature upon first examination of this patient was the moderate proptosis of the left eyeball. Conjunctival edema and vascular congestion were present. There was a small, round scar on the lateral aspect of the nose 1 cm. from the inner canthus of the left eye. Below the tip of the left mastoid was a 2- by 4-cm. scar, which was adherent to the deep structures of the neck.

Neurologic examination disclosed normal direct and peripheral vision. The left neuroretinal outline showed minimal blurring along its nasal margin. The retinal arterioles pulsated, and the veins were full. There was hypalgesia and anesthesia over the third branch of the fifth cranial nerve. There was almost complete paralysis of the circumoral musculature on the left side (fig. 208). There was pronounced atrophy of the sternomastoid muscle on the left. The trapezius muscle was atrophic, with marked winging of the vertebral border of the scapula and loss of abduction of the left arm beyond 90° (fig. 209).

The supraorbital veins were engorged, and a distinct, continuous thrill could be felt in both the upper and lower eyelids on the left side. This thrill was transmitted into the neck over the carotid vessels. Over the left eye, the forehead, and the left side of the neck, there was a harsh, continuous roaring bruit, accentuated in systole. The left

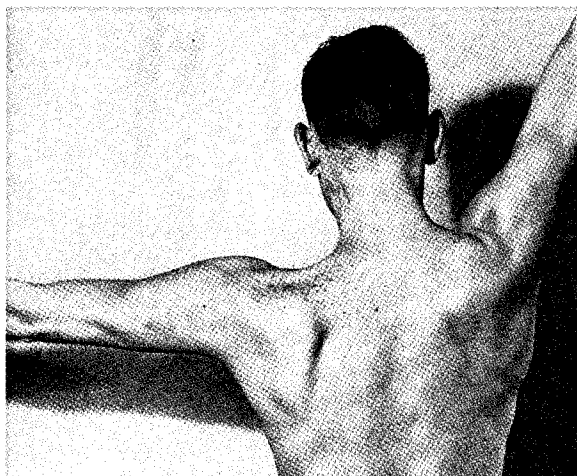

FIGURE 209.—Paralysis of left spinal accessory nerve.
Note wound of exit beneath mastoid region.

eyeball pulsated slightly. The whole picture, which was one of pulsating exophthalmos, was thought to be due to a communication between the cavernous sinus and the left internal carotid artery.

On 26 May 1943, the left common carotid artery was partially compressed with an aluminum band, which, it was thought, stopped about 80 percent of the blood flow through this vessel. After this procedure, there was definite improvement in the exophthalmos.

On 23 June 1943, the carotid artery was again exposed, together with its terminal branches. At this time, temporary occlusion of the common, internal, and external carotid vessels did not obliterate the bruit previously described, and it was concluded that a large blood supply to the fistula was coming from the other side and from the vertebral vessels. At this time, the common carotid artery was doubly ligated with braided silk. After this operation, there was additional improvement in the exophthalmos, although the bruit and thrill were only slightly affected.

The neurologic diagnosis was involvement of the 5th, 7th, and 11th cranial nerves, associated with an arteriovenous aneurysm of the left internal carotid artery and cavernous sinus.

COMMENT

The experience of World War II soon showed that the separation of injuries to the cranial nerves of the neck into separate clinical syndromes was of dubious neurologic value in spite of the close anatomic grouping of these nerves. For one thing, any specific syndrome depended upon the unpredictable vagaries incident to trauma from gunshot wounds. For another, the clinical picture and neurologic findings depended upon the time after wounding at which the neurologic observations were made.

From a study of the cases just recorded and of other traversing wounds of the face and neck in which there were no significant changes at the time the neurologic study was made, several observations of prognostic import may be made, as follows:

1. Injuries of the fifth and seventh nerves, whether transient or, as was most unusual, permanent, might be engrafted upon the usual classical syndromes of the last four cranial nerves. The superimposed neurologic defect exhibited a strong tendency toward spontaneous regression in the cases observed at the vascular centers.

2. Lesions of the last four cranial nerves, whether they were acute or of a chronic and perhaps regressive character, might incapacitate the patient in only two important respects. The first was that some patients, soon after injury, had a great deal of difficulty in swallowing fluids. The second was that abduction paralysis of the vocal cord might be persistent. In two instances at Ashford General Hospital (cases 2 and 3), the induction of anesthesia, preliminary to the introduction of an intratracheal tube, precipitated respiratory collapse.

3. Involvement of the external branch of the spinal accessory nerve usually showed some tendency toward improvement, but the loss of abduction of the upper extremity beyond 90° was likely to remain as a defect of considerable magnitude. Direct exploration of the region of the jugular foramen, with the objective of decreasing this neurologic disturbance, was not carried out, or even contemplated, in any case observed at the vascular centers.

INJURIES OF THE UPPER EXTREMITY

Neural complications, as already noted, have always been known to be much more frequent in injuries of the upper extremity and their sequelae than in those of the lower extremity. Thus Fromme,⁶ in a long and carefully documented article written in 1917, recorded 16 aneurysms of the upper extremity, 13 of which were associated with neural changes. In Maurer's⁷ World War I series of 71 aneurysms of the upper extremity, neural complications were present in 25 percent. In Makins'⁸ experience, the brachial plexus was involved in 25 percent of 28 subclavian aneurysms and in 43 percent of 54 aneurysms of the axillary artery. In this series, nerve injuries occurred in 10 of 43 injuries of the brachial artery. It is of interest that in it, there was only 1 arteriovenous aneurysm, in comparison with 12 arterial aneurysms.

Case Histories

Case 5.—This soldier was wounded 28 March 1943 by a rifle bullet which struck the left clavicular space, traversed the apex of the axilla, and made its exit lateral to the tip of the left scapula. External bleeding was minimal, and there was no later evidence of

⁶ Fromme, A.: Ueber Kriegsaneurysmen. *Beitr. z. klin. Chir.* 105: 293-323, February 1917.

⁷ Maurer, A., Note sur les plaies vasculaires récentes et leur traitement, d'après 444 observations. *Mém. Acad. de chir.* 65: 1156-1164, 8 Nov. 1939.

⁸ Makins, George H.: *On Gunshot Injuries to the Blood Vessels, Founded on Experience Gained in France During the Great War, 1914-18.* London: Simpkin, Marshall, Hamilton, Kent & Co. Ltd., 1919.

a massive subcutaneous hematoma. The left arm became paralyzed at the moment of injury, and for 2 months, there were no signs of improvement. Return of function was marked first by flexion of the forearm and then by extension of the wrist. Sensory loss, which had been noted over the entire arm after injury, regressed slowly until eventually it affected only the outer aspect of the forearm, the thumb, and the index, middle, and ring fingers. After the patient was hospitalized in the Zone of Interior, an aneurysm of the first portion of the axillary artery was found, and he was therefore transferred to the vascular center at Ashford General Hospital.

Examination at this time revealed a small, well-healed wound of entry 4 cm. below the outer third of the left clavicle and an irregular, larger scar, representing the wound of exit, lateral to the tip of the left scapula. An oval, expansile mass, 3 by 2 cm., was palpable in the left infraclavicular space. On auscultation, a faint systolic bruit could be heard, which radiated into the distal third of the extremity. The radial pulse on the left was weaker than on the right, and the ulnar pulse was absent. The blood pressure in the right arm was 122/78 and in the left 110/76 mm. Hg.

Neurologic examination disclosed complete involvement of the musculocutaneous nerve, an incomplete lesion of the median nerve, and minimal disturbance of the radial nerve, with corresponding muscle dysfunction. An area of hypalgesia and anesthesia corresponded to the sensory distributions of the lateral antebrachial cutaneous and median nerves.

When operation was performed 16 August 1943, a false aneurysm of the first portion of the left axillary artery was found and resected. There was an extensive gap in the musculocutaneous nerve, and the mass of the aneurysm compressed the median nerve chiefly. After operation, there was no demonstrable change in the vascular supply to the extremity, but 3 months later beginning improvement in the neural defect was detectable (fig. 210).

Case 6.—This soldier sustained a rifle bullet wound of the upper right chest 23 April 1943. He remained on the field under fire until the following day, when he was again injured, this time by a shell fragment in the right shoulder. As the result of the second injury, the right arm was paralyzed, and the hand and the fingers were in flexion spasm. The hand and arm recovered normal function, as far as the patient could tell, in the following 2 months. Chest pain persisted, and he was evacuated to the Zone of Interior.

On 25 October 1943, in the course of a routine physical examination, a rounded, pulsating mass was palpated high in the right axilla. It appeared to be distinct from the pulsation and course of the axillary artery. A nontransmitted systolic bruit was present over the mass, and both pulsation and mass could be obliterated by compression of the subclavian artery. A small scar was present on the anterior aspect of the right shoulder. Neurologic examination disclosed atrophy of the triceps muscle with associated weakness of extension of the upper arm. The muscle mass of the deltoid was diminished on the right, and the beginning abduction movement of the right arm was weak. There was moderate flaring of the vertebral tip of the right scapula.

On 2 November 1943, exploration of the right axilla disclosed an arterial aneurysm of the long thoracic artery 4 cm. in diameter. The long thoracic nerve curved around the aneurysm and was embedded in the wall. After resection of the aneurysm, inspection of the axillary and radial nerves revealed no gross abnormality.

Case 7.—This soldier was injured by a rifle bullet 23 March 1943. The missile entered the right forearm on the lateral aspect of the middle third, traversed the arm diagonally, and made its exit slightly above the medial condyle of the humerus. The wound of exit bled so profusely that a tourniquet had to be applied. This wound became infected, but the infection cleared up promptly.

As soon as he was wounded, the patient noticed weakness of the handgrip and loss of feeling along the inner aspect of the forearm and the ulnar aspect of the hand, as well as in the fourth and fifth fingers.

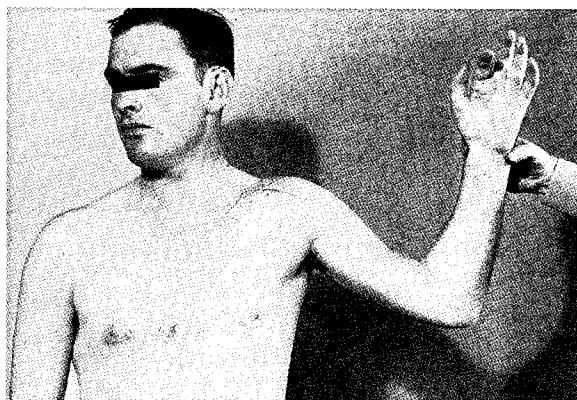

FIGURE 210.—Musculocutaneous and median nerve injury with axillary aneurysm. Note scar of operative approach.

Examination of the right upper extremity 7 May 1943 revealed a tubular swelling of the proximal half of the forearm with a fluctuant area 4 cm. below the medial condyle of the humerus. A systolic pulsation and a systolic bruit were present over this area. Elsewhere, the skin and subcutaneous tissues were firm and indurated. There was no local heat or other change in the overlying tissues. Pressure in the region of the ulnar nerve adjacent to the wound of exit caused a tingling paresthesia. Function had been lost in the flexor carpi ulnaris, the two medial heads of the flexor digitorum profundus, and the intrinsic musculature of the hand innervated by the ulnar nerve. The fifth finger and the ulnar aspect of the hand were analgesic and anesthetic, and a narrow band of hypalgesia was present along the lateral margin of the lower half of the forearm.

Obliterative endoaneurysmorrhaphy of the brachial artery 17 May 1943 produced no alteration in the peripheral nerve supply to the hand (fig. 211). At exploration 14 July, the ulnar nerve was found divided in the thick scar tissue at the site of the aneurysmal sac. End-to-end anastomosis was carried out with tantalum wire, but, at the end of 4 months, no return of function was evident.

Case 8.—This patient was injured by a .30-caliber rifle bullet on 3 July 1943. The missile entered the left forearm on its anterior and lateral aspect and emerged just above and posterior to the medial epicondyle of the humerus. He noticed immediate numbness and weakness of the hand. Within 2 hours of the injury, there was pronounced swelling of the elbow, forearm, and hand, but there was no external hemorrhage. On the seventeenth day after injury, an incision was made below the antecubital space, and much blood clot was evacuated.

On examination at Ashford General Hospital 16 August 1943, healed wounds of entry and exit were noted, corresponding to the path of the missile. The left upper forearm was swollen and indurated. An oval mass, 6 cm. in length, was palpable on the medial aspect of the forearm below the antecubital fold. There was an expansile pulsation in the mass, synchronous with cardiac systole. A loud systolic bruit was audible upon auscultation. Compression of the brachial artery in the arm caused the mass to become smaller and the bruit to disappear. The ulnar pulse was absent. The radial pulse was weaker on the left side than on the right.

Motor examination showed disuse atrophy of musculature of the arm. Minimal radial extension of the wrist was possible. Slight extension of the third finger at the metacarpophalangeal articulation was elicited. No other movements of the musculature of

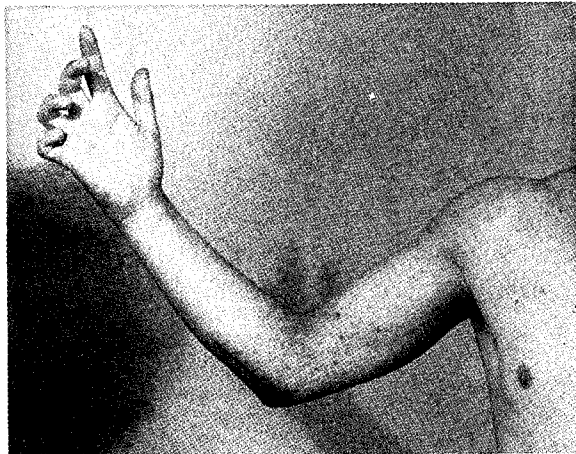

FIGURE 211.—Ulnar nerve paralysis with aneurysm of brachial artery. Endoaneurysmorrhaphy has been performed. Note obvious deformity caused by ulnar nerve injury.

the hand were possible. There was extreme contracture of the flexor tendons to all fingers. The entire hand showed cutaneous atrophy and loss of sweating. Analgesia and anesthesia were present over the sensory distribution of the ulnar and median nerves in the hand.

On 7 September 1943, the arterial aneurysm was resected. The median nerve was found compressed by the mass of the aneurysmal sac, and the ulnar nerve was buried in a mass of scarred, indurated muscle tissue medial to the aneurysm. It was observed that widespread muscle damage was present in the bellies of the flexor musculature of the forearm. Slight improvement in the neurologic status was evident after operation (fig. 212).

Case 9.—A patient with an axillary aneurysm and involvement of the medial and lateral branches of the median nerve was treated at Walter Reed General Hospital, Washington, D.C., by excision of the axillary aneurysm and neurolysis, as follows:

An incision was made over the course of the cephalic vein in the upper arm and extended medially toward the middle third of the clavicle. The tendon of the pectoralis major muscle was reflected medially. The neurovascular bundle was identified, and the median nerve was isolated and followed proximally to the point of injury at the level of the lateral border of the pectoralis minor muscle. The medial antebrachial cutaneous and ulnar nerves were then identified and isolated for a short distance. Stimulation of these nerves revealed intact motor and sensation fibers in the ulnar nerve and intact sensation of the medial antebrachial cutaneous nerve. Stimulation of the median nerve revealed intact sensation and motor power except on the medial border, where the nerve was insensitive and no motor response was evoked by stimulation.

To obtain adequate exposure, it was necessary to divide the pectoralis minor muscle in part. The median nerve, at the point at which branches from the median and lateral cords converge to form the nerve, seemed to be elevated over a 1.5-cm. tumor. This tumor was soft, compressible, and pulsating; it was believed to represent an aneurysm in the axillary artery.

Neurolysis was begun at this point, and, in attempting to separate the aneurysm from the undersurface of the nerve, the aneurysm was broken into by a blunt hemostat. Hemostasis was controlled by digital pressure of the artery over the first rib. An

attempt at suture of the rent resulted in tearing out of the suture material and increased bleeding, so that, to secure hemostasis, it was necessary to isolate the artery superiorly and place a constricting rubber cuff about it. When this had been done, it was possible to separate the small aneurysm completely from the undersurface of the nerve. Very little intrinsic damage was present in the branch from the lateral cord, but, in the branch from the medial cord, there was some soft fusiform swelling.



FIGURE 212.—Preoperative photograph showing aneurysm of brachial artery, with ulnar and median nerve paralysis. Note drainage scar. Insert shows specimen of aneurysm removed at operation.

A neurolysis of the branch from the medial cord was carried out, as well as a neurolysis of the musculocutaneous nerve, which was incompletely incorporated in soft scar.

Attention was then directed toward the aneurysm. To remove it in toto, it was necessary to divide the axillary artery completely. At the site of the rent in the aneurysm, normal appearing intima was seen to merge into a purplish membrane which lined the cavity. The artery was doubly ligated by a ligature and a suture ligature of heavy silk both proximally and distally to the aneurysm, and the aneurysm was removed in toto. The resultant defect in the artery measured about 1.5 cm.

Anatomic restoration of the pectoralis minor muscle and the tendon of the pectoralis major was effected by interrupted sutures of heavy and fine silk. The axillary fascia was closed by interrupted sutures of fine silk to obliterate dead space. The incision was then closed in two layers with interrupted sutures of fine silk.

Sterile pressure dressings were applied, and the arm was put up in modified Velpeau position. At this time, the extremity was warm. The nail beds filled rapidly after blanching, but the pulsations of the radial artery at the wrist could not be identified with any certainty.

Case 10.—A patient with an aneurysm of the brachial artery and involvement of the left median and ulnar nerves was treated as follows at Walter Reed General Hospital:

Under satisfactory local anesthesia, with the patient supine, an incision was made over the neurovascular bundle in the left upper arm, extending above and below the scar of the old bullet wound. The incision was deepened until the median nerve was found lying lateral to the artery below the scar. The nerve was picked up above the scar and traced through this scarred area, in which it was found to pass over a bluish, pulsating mass about 2 cm. in diameter. The ulnar nerve, which was picked up below and above the scar, was likewise found to lie directly under the pulsating mass.

In the belief that this mass probably was an aneurysm of the brachial artery, it was thought best to determine circulation of the hand and forearm after obliteration of the artery, to decide whether it would be safe to remove the aneurysm. After an Esmarch bandage had been placed around the hand and forearm, the artery was occluded below the aneurysm. The bandage was then removed. In approximately 2 minutes, the color returned to normal in the hand. The artery was then occluded above the aneurysm by a rubber-covered artery clamp. At the end of 15 minutes, there was little appreciable change in the color, capillary pulsation, or temperature of the hand. Oscillometric readings showed good oscillation in the artery. Therefore it was felt safe to remove the aneurysm.

After the ulnar nerve had been dissected off from the aneurysm, little scarring was found on the nerve itself, although there was considerable thinning out as it passed over the pulsating mass. When the median nerve was similarly freed up, a small amount of scar tissue was found on its later aspect. Stimulation of the median nerve above the area of involvement resulted in some contraction of the long flexors of the fingers and the pronator teres. Flexion of the flexor carpi nerve and the small muscles of the hand was produced by stimulation of the ulnar nerve above the aneurysm. Stimulation below the aneurysm produced a definite, characteristic sensory response. Division and suture of the median and ulnar nerves was therefore not undertaken, in the belief that, when the pulsating mass had been removed, the function of both nerves would probably return to normal after a period of time.

With the brachial artery occluded above and below the aneurysm, the aneurysmal tract was opened, and about a dram of old, brownish, organized blood clot was removed. There was brisk bleeding from two or three small lateral communicating vessels which entered the aneurysm on the lateral aspect of the arm. Each one of these vessels was carefully closed at its entrance into the aneurysm from the interior of the aneurysm by a purse-string silk suture. The brachial artery itself was occluded above and below by a similar stitch inside the aneurysm. At the end of this procedure, there was no bleeding at all into the open aneurysmal sac. The sac was therefore closed by several interrupted silk sutures; it was not removed because of the danger of disturbing the collateral circulation. The deep fascia, subcutaneous tissue, and skin were closed with silk. The hand was warm at the conclusion of the operation.

Case 11.—The following case represents an uncommon instance of a combined vessel-nerve injury in which an arterial aneurysm had not only compressed peripheral neural tissue but had actually eroded the fascicles to such a degree that partial nerve division ensued. There were only 2 such cases in 1,000 peripheral nerve operations at Walter Reed General Hospital, and in both the pathologic process was discovered only at operation.

The patient whose management is described herewith had a traumatic aneurysm of the ulnar artery which was affecting the ulnar nerve. An incision was made over the ulnar aspect of the forearm in about the midportion, and the previous scar was completely excised. The ulnar nerve was picked up proximal to the scarred area, dissected out distally, and isolated in this position. When dissection was carried distally and proximally from these points, it was found that the artery and nerve were densely bound

together with adhesions. Further dissection revealed a bulbous area, about 1.5 cm. in diameter, which was attached to the ulnar artery and which had apparently eroded the ulnar nerve, except for two fascicles in the posterior lateral portion, which went to the dorsal branch of the nerve. This swelling pulsated and appeared to be a traumatic aneurysm of the artery.

Stimulation of the nerve proximally caused pain but no muscle response. Stimulation distally gave no response on the palmar branch, but pain was complained of when the fascicles to the dorsal branch were stimulated.

When it had been definitely demonstrated that the pulsating swelling was an aneurysm, the ulnar artery was clamped above and below it, the ends were ligated, and the vessel was divided. This area was then dissected out from the surrounding scar tissue. A section of the ulnar nerve was cut out with a sharp razor blade until fairly normal fascicles appeared. The defect measured 5.2 cm.

An incision was made upward over the medial epicondyle. The origin of the flexor carpi ulnaris and the medial epicondyle were divided, and the nerve was dissected free from the surrounding tissue. The fascicular dissection of the branches to the flexor carpi ulnaris and the lateral portion of the flexor digitorum profundus permitted satisfactory transplantation, and the nerve ends could be brought together without tension. After bleeding had been controlled, the nerve ends were sutured with perineural sutures of 0.003 tantalum. The suture line was surrounded with a tantalum cuff. The wound was closed in tiers with interrupted silk sutures, and the arm was put up in a cast to maintain the elbow at 90° flexion.

COMMENT

Peripheral nerve injuries visualized at operation in association with vascular injuries as a rule differed grossly in only two respects from peripheral nerve injuries without associated vascular injuries, as follows:

1. The usual pathologic findings of complete or partial nerve section, contusion, or compression by scar tissue were supplemented by the added factor of compression by the mass of the aneurysmal sac. It was observed in the cases in World War II, as in the few recorded in detail in the earlier literature, that the neurologic defect apparently appeared full blown at the moment of injury. Since spontaneous return of neurologic function seldom occurred, operative repair of the neural lesion was mandatory in all cases.

2. The presence of a vascular lesion with the nerve injury, whether it took the form of transection of the artery or of an aneurysm, tended to exaggerate and make permanent the existing neural dysfunction because of local and general alteration in the nutrition of muscle fibers, which occasionally, as just mentioned, amounted to their severance. The frozen, contracted hand resulting from acute arterial occlusion (fig. 213), which was well recognized before World War II, might be beyond remedy if an uncorrected neural defect was superimposed on it.

In case 7 in this series, the diagnosis of abscess rather than arterial aneurysm was considered, and, in case 8, an incision was actually made for a presumed abscess. In two of the cases reported by Fromme, incision for supposed abscesses caused very severe hemorrhages. In another of Fromme's cases, which resembled cases 10 and 11, the diagnosis of abscess was also entertained, but only briefly.

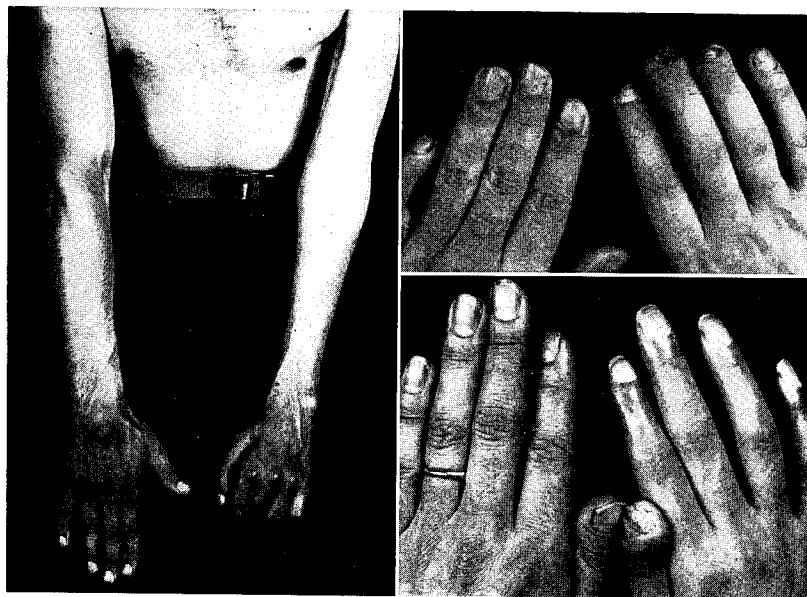

FIGURE 213.—Examples of frozen hands after nerve-vascular injuries. Note changes in nails and fingertips.

INJURIES OF THE LOWER EXTREMITY

It has already been pointed out that neural complications were considerably less frequent in injuries of the lower extremity than in those of the upper. In Makins' series of 170 injuries of the femoral artery, nerve involvement was described as "rare," and neural structures were involved in only 5 of 85 injuries of the popliteal artery. The experiences of the vascular centers in the Zone of Interior in World War II were in general accord with these observations. The sciatic nerve was sometimes involved in traversing injuries in the thigh, and its peroneal and tibial components were sometimes involved in large open wounds of the popliteal space, but these complications were infrequent compared to their incidence in wounds of the upper extremity.

Case Histories

Case 12.—This officer sustained a perforating wound of the thigh when he was struck in the left femoral region by a machinegun bullet 29 April 1943. The wound of exit was in the left buttock. The extremity was paralyzed and became anesthetic at the time of impact, but motor and sensory defects cleared within a few hours. A profuse external hemorrhage was controlled by pressure. Pain in the calf and the popliteal space developed early although there was no evidence of circulatory deficiency. The distress increased with the appearance of a harsh bruit over the femoral triangle, dilatation of the veins of the leg, and some peripheral cyanosis. On 11 June 1943, the left femoral artery and vein were ligated proximal to the fistula without alteration in the peripheral circu-

lation and without effect upon the aneurysm. At this time, cardiac studies were normal.

On 11 July 1943, examination at Ashford General Hospital showed induration in the left femoral triangle. About 8 cm. below Poupart's ligament was a small wound of entry beneath, and lateral to, a well-healed surgical incision. A second surgical incision was situated lateral to the first. A scar representing the wound of exit was noted in the left buttock. Beneath the larger incision, a loud, harsh bruit was audible throughout systole and diastole; it was accentuated during the systolic phase. Occlusion of the femoral artery above the fistula diminished the bruit but did not cause it to disappear. The occlusion caused a transitory slowing of the pulse rate. The peripheral pulses were absent in the left lower extremity, and there was slight dependent cyanosis of the foot. Definite enlargement of the heart to the left was confirmed by fluoroscopy.

Neurologic examination revealed only a diminution of the left knee kick and weakness in dorsiflexion of the left great toe. There were no sensory changes. The left sciatic nerve was somewhat tender, and pressure over it increased the peripheral pain.

On 4 August 1943, quadruple ligation and resection of the arteriovenous fistula was performed. Convalescence was uneventful, and the radiating pain slowly diminished.

Case 13.—This medical officer received multiple injuries of the trunk, abdomen, and upper and lower extremities from the explosion of a landmine in April 1943. He remained dazed and disoriented for several days as the result of blast concussion. At this time, he recognized the presence of a right ulnar nerve paralysis and appreciated an area of numbness over the lateral aspect of the right lower leg. He stated that there had been profuse hemorrhage from a broad laceration of the right popliteal space at the time of injury, which necessitated several plasma and whole blood transfusions. A month after the injury, the ulnar nerve paralysis began to recede, and the patient became conscious of a continuous thrill in the popliteal space. He was the first to recognize the presence of an arteriovenous aneurysm of the popliteal vessels. He noticed no symptoms referable to cardiac strain except shortness of breath, and he did not feel that the peripheral blood supply to the involved extremity was impaired.

Examination at Ashford General Hospital was noteworthy for the presence of 28 separate scars over the posterior surface of the trunk and lower extremities (fig. 214), which is characteristic of multiple injuries from the explosion of an antipersonnel landmine. Over the inferior aspect of the right popliteal space was a broad, irregular scar, extending laterally beneath the tibial tubercle. Above this scar, and rather high in the popliteal space, the tissues appeared full. Upon palpation at this point, a strong continuous thrill could be felt. Upon auscultation, the bruit was continuous but was accentuated with systole. There was no evidence of cardiac damage, and the peripheral blood supply of the foot was normal. Hypalgesia and hypesthesia were present over the sensory distribution of the sural nerve. There was no evidence of motor dysfunction in this extremity. Neurologic study elsewhere had disclosed only hypalgesia over the cutaneous area innervated by the ulnar branch of the medial antebraichial cutaneous nerve.

On 24 August 1943, the arteriovenous aneurysm was excised after quadruple ligation. At operation, the peroneal nerve was found compressed by scar tissue, and an external neurolysis was done. The neurologic defect improved steadily, and the patient was able to return to duty.

Case 14.—When patients with peripheral nerve injuries present themselves relatively early after injury, the concomitant edema and induration of tissue recently subjected to trauma may hide the coexistence of an arterial aneurysm, particularly when investigation of the vascular lesion is difficult because of the protection of the lesion by the muscular tissue of the thigh. The following operative note from Walter Reed General Hospital in an injury of the sciatic nerve and profunda femoris artery should serve as a warning to the inexperienced or unwary military neurosurgeon:

With the patient face down on the operating table, an incision was made, under local anesthesia, from the edge of the gluteus maximus directly down the back of the

thigh over the course of the great sciatic nerve. The fascia over the biceps was divided, the two heads of the biceps separated, and the sciatic nerve identified and isolated between the two heads of the hamstrings. Stimulation at this point produced pain in all parts of the foot but no muscle response. Dissection was then carried upward between the two heads to a point at which the sciatic nerve was apparently greatly thickened and was densely bound down to all the soft tissues. There was extreme edema and swelling of the tissues, which were quite dense.

The posterior femoral cutaneous nerve was picked up, dissected free, and retracted laterally. It then became apparent that the gluteus had to be reflected, and a Naffziger incision was therefore made. A curved incision was made from the posterior superior iliac spine and was swung out laterally over the head of the femur.

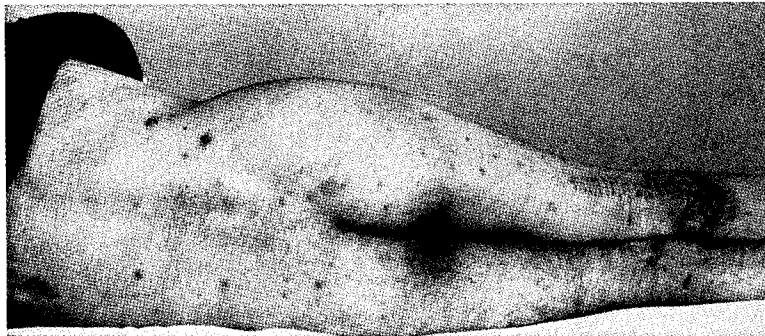

FIGURE 214.—Popliteal aneurysm with involvement of sural nerve. Note multiple injuries caused by explosion of landmine.

The incision was carried down to fascia. The insertion of the gluteus maximus was then cut free from its insertion into the trochanter of the femur. All these tissues were also greatly thickened and edematous and were bound together with adhesions. They were yellowish.

When the insertion of the gluteus maximus was divided, there appeared to be a hole in the underlying tissues, just medial to the head of the greater trochanter of the femur. Old blood clots were coming through this hole. After it was slightly enlarged, it became apparent that a tremendous hematoma underlay the gluteus muscle. A larger opening was then made, and the hematoma was gradually evacuated. When it was being evacuated in the region of the posterior aspect of the femur, there was an immediate gush of fresh blood. By the use of numerous retractors and two suckers, it was possible to expose the bleeding point, which was apparently the profunda femoris artery; it was tied with a silk suture. The hematoma appeared to contain about 1,500 cc. of blood clots of varying ages; some were completely organized, and some consisted of black, thick, fluid blood.

The sciatic nerve, which seemed to be intact, passed up superficially to the blood clot on the undersurface of the gluteus muscle and then curved over the clot down through the sciatic notch. There was great thickening, swelling, and adhesions of the tissues surrounding the entire nerve, but it was apparently intact.

After the hematoma had been completely evacuated, a large piece of oiled silk was placed gently into the cavity and was packed in lightly with a gauze roll. A perforated tube led into the pack. The lower portion of the wound was closed by closing the fascia over the hamstrings and by suture of the insertion of the gluteus maximus. The pack was brought out under the lower edge of the gluteus maximus deep to the sciatic nerve and then through a stab wound in the lateral posterior portion of the upper thigh; the

exit was kept as far from the anus as possible. The wound was closed in tiers with interrupted silk sutures, and penicillin was injected locally.

The entire procedure was carried out under local anesthesia. The patient received plasma and blood during the operation, when bleeding occurred, and he was in good condition when he was taken off the operating table.

PERIPHERAL NERVE INJURY WITH VASCULAR OCCLUSION

As has already been pointed out and demonstrated by illustrative cases, the neuropathologic process in combined vascular-nerve injuries differs in only two respects from the process commonly seen in all peripheral nerve injuries. First, there are the usual findings of nerve division, which, alone or in combination, may be complete or partial, neuroma in continuity, and transient block. To these neurologic findings is added the relatively pure factor of compression, characteristically rapid, of an expanding aneurysmal mass. Second, the arterial aneurysmal mass may produce various degrees of distal tissue hypoxia. A third form of neural involvement, not yet widely recognized, is a true division of nerve fibers through erosion of a pulsating mass, a process similar to the classical vertebral erosion observed in large aneurysms of the aorta.

When acute vascular occlusion was present, still another form of neural pathologic process might occur from actual ischemia of peripheral nerve tissue. The result might be a complete and possibly irreparable peripheral nerve lesion, even though major nerve trunks remained intact. If the vascular lesion was associated with nerve severance, nerve regeneration was imperfect if it occurred at all, no matter how satisfactory the nerve suture might be.

The original neural loss and the degree of subsequent regeneration depended quantitatively upon the initial deprivation of blood supply and the intraneural changes which resulted. When failure of function in necrotic muscle was combined with failure of nerve regeneration in residual undamaged muscle, with poor sensory return, the resulting clinical deformity and dysfunction produced a gloomy picture indeed (fig. 213). The syndrome described, which was much more common and disabling in the upper than in the lower extremity, is illustrated in the following four case reports, which also indicate possible methods of therapy.

Case Histories

Case 15.—This soldier sustained a compound fracture of the left humerus when he was wounded by a shell fragment 17 July 1944. Debridement was done several hours later. According to the surgeon, the median, ulnar, and radial nerves were affected, but he found no evidence of vascular injury. A body cast was applied. On 26 July, delayed primary wound closure was done, with the application of a hanging cast. The wound drained purulent material until the middle of August. During this time, the fingers and hand became very swollen, indurated, and stiff. Plaster fixation was maintained until the patient was admitted to Walter Reed General Hospital on 8 October 1944.

At this time, the extremity presented the classical picture of an ischemic contracture.

The skin was shiny and smooth. There was woody atrophy of the musculature of the forearm. The wrist was slightly flexed, with extension limited to 20°. The fingers were flexed, and the thumb was held rigidly in adduction (fig. 215). No radial or ulnar arterial pulsation was present. There was weak action of the pronator teres and flexor carpi radialis. All other muscles of the forearm and hand were paralyzed. Sensory examination showed complete analgesia and anesthesia over the sensory domain of the ulnar and median nerves, with hypalgesia over that of the radial nerve.

At operation, under local anesthesia, an incision was made over the course of the neurovascular bundle in the left upper arm, extending into the axilla downward over the course of the ulnar nerve behind the medial epicondyle. The scar on the medial aspect of the upper arm was excised. All the tissues showed considerable fibrosis, induration, and rigidity. The elbow could not be extended beyond 90°.

The ulnar and median nerves were identified in the region of the wound. The median nerve showed some scarring about it, but stimulation produced some motor response in the forearm, and stimulation well distal to the wound produced a sensation of pain over the median distribution. The ulnar nerve, however, showed a dense, scarred fusiform neuroma, through which no satisfactory motor or sensory response could be obtained. This neuroma was excised, which left a defect of about 3½ cm. In order to eliminate any possible tension, the nerve was dissected downward to the region of the elbow and transposed anteriorly; the branches to the flexor carpi ulnaris were split to provide sufficient mobility to bring the nerve anteriorly. This procedure provided sufficient length to permit suture in the upper portion of the arm in the region of the wound. An end-to-end anastomosis of the ulnar nerve was done in this region, using 0.003 tantalum wire. A small cuff was placed around the suture site. The tantalum foil held its position by its own tensile coil strength.

A very hard nodule occupied the greater portion of the lower half of the biceps muscle. A biopsy revealed, instead of normal muscle, grayish-white fibrous tissue, indicative of severe vascular occlusion.

The wound was closed in two layers with interrupted silk sutures. No cast was necessary, because of the inability of the patient to extend his arm because of fibrous fixation.

Case 16.—This 24-year-old soldier sustained a complete, compound, comminuted fracture of the proximal third of the left ulna, with loss of approximately 5 cm. of the substance of the bone, as the result of a shell fragment injury 6 March 1944. On the same day, the wound was debrided, and the ulnar and radial arteries were ligated with chromic catgut. The ulnar and radial nerves were dissected out and buried in muscle tissue. Stellate block was performed immediately after operation and again on the following day.

A draining sinus over the ulnar aspect of the left forearm developed and persisted. Circulation to the left hand was always described as "good." On 17 March, the patient could move his thumb and forefinger. There was loss of sensation to pinprick over the ulnar nerve distribution.

On 20 September 1944, the left hand was manipulated under general anesthesia. Soon after this procedure, the posttraumatic deformity returned, and the patient was able to move his third finger only. After the injury, he noticed that exposure to a cool environment, even with the hand adequately protected, gave rise to severe aching pain. At times, even in a warm room, he suffered from intermittent aching of the left hand. He described the pain as a diffuse, severe aching, which he could not localize. Exposure to a cool environment, in addition to intensifying his pain, gave rise to deep cyanosis and marked coldness of the hand. Exposure to extreme warmth likewise intensified the pain. Partial relief was obtained by massage in cold water. On an average of two or three times weekly, he was awakened from sleep, or he found it difficult to fall asleep, because of pain in his hand. He noted no hyperhidrosis or involuntary twitching of the muscles. Tapping the tips of his fingers produced electric shocklike sensations which



FIGURE 215.—Frozen hand resulting from occlusion of brachial artery and median-ulnar nerve injury.

radiated up the arm. He stated that he would prefer to have the hand amputated, since he thought a hook would be far more usable.

This patient had no history of frostbite, trenchfoot, cellulitis, lymphangitis, or thrombophlebitis.

A draining sinus was present over the middle third of the ulnar aspect of the left forearm. There was marked axillary adenopathy on this side. A firm, nontender nodule was present over the medial aspect of the arm just above the medial epicondyle. The radial and ulnar pulses were not palpable on the left but were normal on the right. Normal brachial and axillary pulses were palpable bilaterally. Dorsalis pedis pulsations were absent.

There was anesthesia over the ulnar distribution of the hand and forearm. A typical main d'accoucheur deformity (fig. 216) was present. There was hypesthesia over the median nerve distribution of the palmar surface of the left hand. Muscle (faradic) testing revealed extreme diminution to complete loss of muscle function over the median and ulnar nerve distribution. There was mild elevation pallor of the left palm and intense dependent cyanosis.

Roentgenologic examination revealed marked bony atrophy with apparent soft-tissue contraction.

Allen's test revealed marked delay in the left palmar flush following release of proximal compression.

The first oscillometric readings were as follows:

Anatomical location:

Foot:	
Right	½
Left	½
Ankle:	
Right	4
Left	4
Wrist:	
Right	3
Left	½

Anatomical location—Continued

Forearm just below elbow:	
Right	5
Left	2
Arm just above elbow:	
Right	9
Left	8

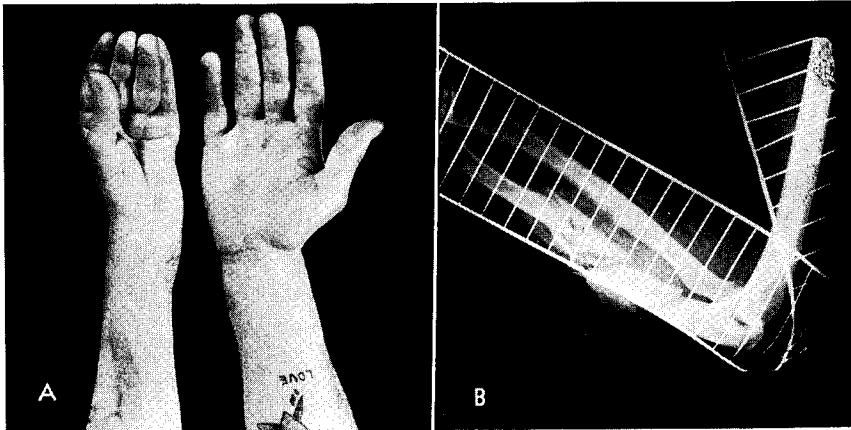

FIGURE 216.—Ischemic contracture of hand from ligation of median and ulnar arteries with injury in continuity of median-ulnar nerves. A. Main d'accoucheur. B. Roentgenogram showing fracture of ulna.

Later oscillometric readings were as follows:

Anatomical location:		Anatomical location—Continued	
Palm:		Forearm:	
Right -----	$\frac{3}{4}$	Right -----	6
Left -----	$\frac{1}{8}$	Left -----	$\frac{3}{4}$
Wrist:		Arm:	
Right -----	$3\frac{1}{2}$	Right -----	$6\frac{1}{2}$
Left -----	$\frac{3}{4}$	Left -----	$6\frac{1}{2}$

The pulse waves recorded by oscillometer over the left palm, wrist, and forearm showed slow ascending and descending limb characteristic of proximal arterial obstruction.

Dorsal sympathectomy improved this patient's subjective reactions of pain, but no improvement in function was noted during the period of hospitalization.

Case 17.⁹—This 30-year-old soldier had never suffered from any signs or symptoms suggestive of peripheral vascular disease of the upper or lower extremities. He had never had phlebitis, cellulitis, or lymphangitis. He smoked about 20 cigarettes a day, drank only socially, and used no drugs.

On 10 September 1944, while in combat against the enemy, he sustained a shell fragment wound of the left elbow. No spurting from the wound occurred, and he immediately applied a tourniquet, which controlled the bleeding. The tourniquet remained in place for about 10 or 15 minutes. Immediately after the injury, the left upper extremity was devoid of motor power and sensation from the elbow down.

The arm was placed in a cast, which was removed when the wound stopped draining. Upon removal of the cast, the left hand swelled considerably and became deep blue in color. Shortly after, an operation was performed, as a result of which he was able to flex his second and third fingers and extend his wrist partially. Apparently this procedure was a nerve suture.

During the postoperative period, the patient suffered from drawing, aching pain that "drove him crazy." This pain was constant and involved the entire left hand. It varied in intensity and was aggravated by cold, damp, and rainy weather. Heat apparently

⁹The oversea chart on this patient was not available, and the data recorded were secured by questioning him.

did not influence it. On one occasion, the patient rested his hand against a hot water bottle which did not seem extraordinarily warm to his normal right hand but which caused blistering of the index and fifth fingers on the left hand. The blister over the index finger healed rapidly, but an indolent ulcer formed at the tip of the fifth finger, which was covered with a dry, brownish crust after that time. There was intermittent hyperhidrosis of the left hand. Medication afforded little relief of the pain.

Examination revealed a well-developed, well-nourished white soldier, who appeared to be suffering from pain in his left hand. He kept the hand shielded, moved it gingerly and involuntarily retracted it when the examiner approached. There was a 3-cm. transverse scar just proximal and medial to the left olecranon. A 90° flexion deformity was present at the left elbow. There was partial flexion contracture of all fingers, with anesthesia of the entire palm and dorsum of the left hand. Percussion over the anatomic snuffbox and over the pisiform bone gave rise to radiating paresthesias over the hand. There was an indolent ulcer covered with a dry brown crust over the tip of the left fifth finger.

The right hand was moister than the left. The left was cooler than the right. There was dependent cyanosis and mild elevation pallor of the left hand. Allen's test revealed a normal response on the right; there was a 2-second delay on release of radial and ulnar compression on the left. All peripheral pulses were palpable and of normal amplitude with the exception of the radial and ulnar pulsations on the left and the brachial pulsation in the left antecubital fossa. Axillary and brachial pulsations in the left arm were normal. Blood pressure on the left was 138/96 and on the right 148/96 mm. Hg. Good brachial pulsations were palpable in the left arm to a point about 2 cm. above the flexor crease of the elbow. No bruits were audible in the antecubital fossa.

Actively pulsating collaterals outlined on the patient's skin were present over the entire posterior aspect of the elbow and over the posteromedial, posterolateral portions of the arm and forearm; they probably represented dilated superior and inferior ulnar collaterals, radial collaterals, and radial and ulnar recurrent arteries. It was most probably by means of these anastomoses with the unobstructed portions of the radial and ulnar arteries in the forearm that circulation to the hand had been maintained.

At operation, an incision was made from the lower third of the left upper arm over the region of the brachial artery, over the medial aspect of the antecubital fossa, and down over the lateral upper third of the forearm. The incision was carried down to the fascial plane, and skin flaps were reflected on either side. The cutaneous nerves and the basilic vein were dissected out and retracted. Then the median nerve was isolated about 4 cm. above the medial epicondyle and followed down to the upper border of the pronator muscle. At this point, the nerve was closely and firmly bound down by the bicipital fascia.

The brachial artery lying lateral and behind the nerve was pulsating vigorously at the point of the first dissection, but as it was followed distally and began to divide, pulsation stopped, apparently because of thrombosis.

The ulnar nerve was next isolated above the medial epicondyle. It too was firmly bound down by the lateral border of scar tissue arising from the perforating wound. It was freed from these tissues and also from its normal course in the epicondylar groove. The nerve was slightly enlarged and slightly firmer than usual. Stimulation gave good flexion of the hand. The motor branches to the flexor carpi ulnaris were identified and reacted normally. Below this point, for a distance of 4 cm., normal sensory responses were obtained.

Dissection was then carried out below the pronator, and various muscle branches to the pronator, to the flexor carpi radialis, and to the flexor digitorum sublimus and profundus were isolated in this region. Stimulation of these branches gave normal responses.

At this point, a very interesting finding was noted. The lower third of the muscle bellies was completely transformed, with a sharp demarcation point, into necrotic tissue

which was rubberlike in consistency and almost pure yellow. Obviously the vascular lesion had produced necrosis of the muscle bellies, and the peripheral sensory loss was due to a similar vascular process. A biopsy was taken of normal and necrotic muscles.¹⁰

When the brachial artery was divided at the point of presumed thrombosis, it was found completely thrombosed. A biopsy was taken of this tissue and also taken of a small cutaneous nerve.

The median nerve, below its muscle branches, was somewhat soft but gave a good sensory response. The entire nerve was thoroughly freed from surrounding scar tissue beneath the pronator.

The incision was closed in tiers with interrupted fine silk sutures. A firm pressure dressing was applied.

Case 18.—This patient sustained a wound from a pistol bullet on 29 September 1944. The small wound of entry was near the right nipple, and the entire right arm became numb and paralyzed at the moment of wounding. Examination a few hours later disclosed "an enormous swelling in the right pectoral region and the right axilla." There was no overlying pulsation or bruit. The right hand was cooler than the left. The blood pressure in the left arm was 120/80 mm. Hg. It could not be obtained in the right arm. The right radial pulse was absent. There was diminution to pain perception over the distribution of the median nerve. There was no record of motor involvement.

On 30¹ September 1944, a hematoma containing an estimated 1,000 cc. of blood was evacuated, and a laceration of the axillary artery was visualized. The vessel was divided and ligated. No injury to adjacent nerve trunks was noted. At the end of this procedure, the right hand was cold and cyanotic. When block of the sympathetic nervous system at T₁, T₂, and T₃ was done with 1 percent procaine, the hand became pink and warm. Smaller blocks were done on T₁, T₂, and T₆, on 4 and 28 October. On 6 October, motion was noted in the fingers. On 14 October, sensation had returned to the arm but not to the hand.

The patient was seen in Walter Reed General Hospital 28 January 1945. The radial pulse was barely palpable. The musculature of the forearm, though spindly, exhibited normal movements. The thumb was partially adducted, and there was minimal induration in the first interosseous muscle (fig. 217). There was incomplete extension of the distal phalanges of the second and third fingers, with a tendency toward ulnar displacement of these digits. There was mild hypalgesia over the tip of the index finger and the medial border of the thumb. The patient had no symptoms referable to this extremity except clumsiness in fine movements of the fingers.

COMMENT

The eventual fate of these badly injured extremities in which a combination of peripheral nerve injury and tissue ischemia produced the so-called frozen hand could not be determined while the patients were under treatment and observation in U.S. Army hospitals. Every attempt was made to follow them up in the Peripheral Nerve Registry.¹¹

The proper treatment of these combined injuries immediately after wounding was never clarified during World War II. Indeed, there is considerable question whether they can be so controlled as to prevent func-

¹⁰This case is described and illustrated in the "Atlas of Peripheral Nerve Injuries" by William R. Lyons and Barnes Woodhall. Philadelphia: W. B. Saunders Co., 1949, case 160, p. 218.

¹¹As noted elsewhere, this task was accomplished in 3,656 of these World War II peripheral nerve injuries by the Follow-Up Agency of the National Research Council developed by the Committee on Veterans Medical Problems in cooperation with the Veterans' Administration, the Army, and the Navy (p. 230).



FIGURE 217.—Facsimile of frozen hand following division of axillary artery and partial injury of median nerve. Treatment with repeated sympathetic blocks with procaine hydrochloride was instituted promptly, and useful function was retained.

tional sequelae, regardless of the methods used. One point, however, is clear, that the use of firm casts and the failure to interrupt the sympathetic nerve supply to the damaged extremity are factors in the production of this deformity.

MANAGEMENT OF COMBINED VASCULAR-NERVE INJURIES

The management of combined vascular-nerve injuries at the vascular centers in the Zone of Interior was based on the principle that a single inclusive surgical approach to the combined lesions was preferable to their surgical repair at separate operations. Close cooperation between specialists in diverse fields was essential in every case. In the management of the individual lesions, the same principles of therapy were applied as if the vascular and the nerve lesions had occurred independently.

Operation for neither arterial nor arteriovenous aneurysm was ever regarded as an emergency unless there was rapid progress in the size of the lesion, rupture had occurred or seemed impending, or heart failure seemed impending. In the absence of these indications, time was allowed for the collateral circulation to develop, which usually took 3 to 4 months. In the meantime, artificial means to develop collateral circulation were employed.

The choice of the surgical procedure depended upon the findings in the

individual case. For arteriovenous fistulas, excision and quadruple ligation soon became the preferred method, while for aneurysms, especially those of the common femoral and other major arteries, in which nutrition to the extremity was questionable, the endoaneurysmorrhaphy of Matas was most generally used.

Although the majority of arterial aneurysms presented themselves as palpable, pulsating masses lying over major vascular channels, they were sometimes found quite unexpectedly during exploration of an extremity for the repair of major injuries of the peripheral nerves. Even the most careful preoperative examination occasionally failed to disclose the presence of the vascular lesions, both because they were of small size and because they might be imbedded in a mass of indurated scar and neural tissue. The neurosurgeon, in the absence of more expert aid, had to be prepared to deal with such lesions, since clinical evidence had made it clear that the combined repair of nerve and vascular injuries was preferable to staged operative procedures. Cases 11 and 19 describe the unexpected finding of vascular lesions in the course of exploration for nerve injuries.

When the proper time had arrived for an attack upon the injured blood vessel, the evidence of extensive nerve damage apparent when the patient was first injured had sometimes resolved to a considerable degree, leaving a residual neurologic defect which offered no serious problems. A conservative attitude was always taken toward all technical procedures, especially in injuries in which nerve compression had occurred because of, or had been increased by, the presence of an aneurysmal mass. The mass of a false aneurysm often produced added nerve damage, but arteriovenous fistulas were seldom large enough to have this effect unless the lesion was complicated by the presence of a false sac on the arterial aspect of the injury. The nerve damage, when this association was present, had apparently occurred when the fistula was formed, as the result of the same inflicting force, and took the form of concussion, contusion, or actual nerve section.

Although neurosurgeons had a fairly adequate working knowledge of peripheral nerve injuries combined with the formidable vascular lesions described in this chapter, not much can be stated authoritatively concerning the therapeutic concepts and practices most effective in ischemic nerve injury. When the sequelae of vascular occlusion had become established in the tissues of an extremity, the neurosurgeon was reduced, or elevated, to the status of a neuropathologist and could do no more than visualize the irreparable changes in tissue sections. About the only hopeful approach to the prevention of ischemic damage was prompt sympathetic denervation of the affected limb. This technique is discussed in detail in the volume devoted to vascular surgery in this series of histories.¹²

¹² Medical Department, United States Army. Surgery in World War II. Vascular Surgery. Washington: U.S. Government Printing Office, 1955.

OTHER ASSOCIATED INJURIES

Fractures

Although fractures occurred in association with nerve injuries with considerable frequency, they furnished only occasional problems in the Zone of Interior vascular centers for the reason that they were usually healed, or well on their way to healing, by the time the patients were received. Even if healing was not complete, arterial lesions were seldom operated on, except for special indications, under 3 months, which usually gave even serious fractures ample time for recovery. In numerous instances, as a matter of fact, the arterial and arteriovenous aneurysms became evident, and presumably developed, while the patients were hospitalized for fractures.

An occasional combination of bone and nerve injuries gave rise to diagnostic problems, as in the following case:

Case 19.—A 21-year-old American soldier was captured by the enemy shortly after he had received an injury of the right forearm from machinegun fire. He was given first aid in an enemy installation. Within 24 hours, he was released by American troops and underwent debridement in a U.S. Army hospital. The arm was placed in a plaster cast. Roentgenologic examination at this time showed lateral displacement of the fragments of the radius. Delayed primary closure of the wound was carried out 20 days later, and the cast was replaced. Thirteen days later it was changed, and traction was instituted through the thumb for the correction of the lateral radial displacement.

The patient was received on the orthopedic service of Ashford General Hospital 9 weeks after he had been injured. Examination at this time showed a healed wound of entrance on the ulnar aspect of the lower third of the right forearm and a healed wound of exit on the radial aspect of the upper third. Flexion of the right index finger was limited, and there was complete loss of pronation and supination of the right forearm. Palpation revealed a firm, nontender swelling over the midportion of the radius. Hypesthesia was present along the distribution of the superficial radial nerve. Roentgenograms showed the same lateral displacement of the radial fragments as had been present 24 hours after injury.

At operation, which was undertaken with the intention of excising the deformity of the radius and bridging the resulting defect with a tibial graft, a false aneurysm, about 5 cm. in diameter, was found between the radius and the ulna. When the tourniquet was released, blood spurting from a small opening on the volar surface of the interosseous artery. The vessel was ligated proximal and distal to the opening, and the false sac was excised. The operation on the radius was carried out according to plan.

The postoperative course was entirely uneventful. Within 6 months, supination of the right forearm was normal, and pronation was 60 percent of normal.

The aneurysm in this case was not suspected before its discovery at operation. The circumstances prove again the importance of a deliberate search for a possible arterial lesion in all combat-incurred bone injuries. They also suggest that the presence of an aneurysm should be suspected when a bone deformity following a comminuted fracture is uniform and persistent. In this case, the lesion apparently achieved its maximum size immediately after injury. It should be noted that recovery was without complications following a combined attack on the bone and nerve lesions and that the end results were also satisfactory.

Soft-Tissue Injuries

Soft-tissue injuries of considerable extent were less frequent in combination with vascular injuries than either nerve injuries or fractures. Only seven were reported in combination with aneurysms and arteriovenous fistulas in the vascular centers of the Zone of Interior. The explanation is probably that when soft tissue was extensively lacerated, blood vessels were completely severed, and under these circumstances aneurysms and arteriovenous fistulas obviously cannot develop.

CHAPTER XIX

Causalgia Following Combat-Incurred Injuries of the Peripheral Nerves

Frank H. Mayfield, M.D.

GENERAL CONSIDERATIONS

Burning pain as a sequel of wounds of the peripheral nerves had been recognized for some time before Mitchell, Morehouse, and Keen¹ applied the term "causalgia" to it in 1864, in their text on injuries of the nerves. In spite of its frequency, it does not appear in the index of the section on neurosurgery in the official history of the U.S. Army Medical Department in World War I or in the statistical volumes.

In 1922, Leriche² recommended interruption of the sympathetic nervous system to control the pain, and his observations were subsequently confirmed by many other observers, including, among others, Spurling,³ Ross,⁴ Kwan,⁵ White and Smithwick,⁶ and Livingston.⁷ Until World War II, the literature on the subject was limited to this and other methods of treatment and to discussions of the etiology, for which many conflicting theories were advanced (p. 474).

The prompt establishment of neurosurgical centers in both British and U.S. Army hospitals in World War II brought under the attention of experienced neurologists and neurosurgeons large numbers of casualties with peripheral nerve injuries and provided unparalleled opportunities to study the sequelae of these injuries. It soon became apparent that causalgia was relatively common. It also soon became apparent that if certain criteria were adhered to in the diagnostic routine, there was almost absolute assurance that relief could be provided by interruption of the appropriate portion of

¹ Mitchell, S. Weir, Morehouse, George R., and Keen, William W.: *Gunshot Wounds and Other Injuries of Nerves*. Philadelphia: J. B. Lippincott Co., 1864.

² Leriche, R.: A propos de la nature des troubles trophiques consécutifs à la section du nerf sciatique et de leur traitement. *Bull. et mém. Soc. nat. de Chir.* 28: 1071-1073, 18 Oct. 1922.

³ Spurling, R. G.: Causalgia of the Upper Extremity, Treatment by Dorsal Sympathetic Ganglionectomy. *Arch. Neurol. & Psychiat.* 23: 784-788, April 1930.

⁴ Ross, J. P.: Symposium on Sympathectomy. Sympathectomy for Median Causalgia. *St. Barth. Hosp. J.* 66: 39, 1933.

⁵ Kwan, S. T.: The Treatment of Causalgia by Thoracic Sympathetic Ganglionectomy. *Ann. Surg.* 101: 222-227, January 1935.

⁶ White, James C., and Smithwick, Reginald H.: *The Autonomic Nervous System; Anatomy, Physiology, and Surgical Application*. 2d ed. New York: The Macmillan Co., 1941.

⁷ Livingston, W. K.: *Pain Mechanisms. A Physiologic Interpretation of Causalgia and Its Related States*. New York: The Macmillan Co., 1943.

the sympathetic nervous system. There was, however, never sufficient uniformity of opinion concerning management to warrant the issuance of directives, and treatment was therefore left to the discretion of the chiefs of the neurosurgical centers.

INCIDENCE

Pollock and Davis'⁸ report of 38 instances of causalgia in 1,020 peripheral nerve injuries, 3.6 percent, provides the only figures available for this complication in World War I, and no statistics at all exist for previous wars.

In the absence of official data on the incidence of causalgia in World War II, questionnaires were sent to a number of former medical officers who had headed neurosurgical centers or served on neurosurgical services. The 13 replies received produced a total of about 500 cases. Only nine reports, however, were received in sufficient detail for tabulation, and many specific data are missing in them (table 12). A few other figures are available. For the Navy, Capt. James C. White, (MC) USN, and his associates, in 1946, reported 13 instances of causalgia in 400 nerve injuries, 3.25 percent. This report was made before the Harvey Cushing Society.

It should be emphasized that none of the reports cited are really definitive. They represent simply the experiences of individual medical officers or consist of series of cases collected over varying periods of time.

The experience at the Percy Jones General Hospital, Battle Creek, Mich., is probably typical. Early in the war, when only patients with constant, severe pain were classified as suffering from causalgia, the incidence was 2 percent (15 cases in 736 peripheral nerve injuries). Later, the incidence rose to 4.5 percent (105 cases in 2,318 nerve injuries). These 105 cases are exclusive of patients who had recovered spontaneously or who had been relieved by sympathectomy before they were received at the Percy Jones General Hospital Neurosurgical Center.

The increased incidence is open to two explanations, as follows:

1. Many cases were originally classified as mild which later proved to be severe. When the patients were protected from noxious stimuli, as was possible in the environment of the hospital ward, their complaints were minor. Later, when they were transferred to reconditioning centers, it was found that mass calisthenics, physical therapy, and the unprotected life in barracks made the pain so severe that many patients had to be rehospitalized for operation.

2. The increased incidence of causalgia later in the war may also be explained by the increased speed of evacuation from oversea theaters as air transportation was developed. In 1945, casualties were sometimes admitted to neurosurgical centers in the United States within 2 weeks after wounding

⁸ Pollock, Lewis J., and Davis, Loyal: *Peripheral Nerve Injuries*. Hoeber's Surgical Monographs. New York: Paul B. Hoeber, Inc., 1933.

TABLE 12.—Data on causalgia obtained by postwar questionnaires to former medical officers in charge of neurosurgical centers or services

Hospital and neurosurgeon	Incidence	Criteria of diagnosis	Complete nerve injuries	Single or repeated blocks of sympathetic chain	Results of treatment		
					Complete sympathectomy	Neurolysis	Neurorrhaphy
Wakeman General Hospital (Capt. Emil Seletz, MC).	15 (1.0 percent) of 1,567 nerve injuries.	Severe, constant burning pain of extremity, unre- lieved by rest or sedation. Skin tender and glossy. Extremity held in position of guarding. Frequent crying.	1 (atypical).	1 relieved by single block.	Not performed.	Not performed.	14 completely relieved.
Ashford General Hospital (Lt. Col. George L. Maltby, MC).	67; number of nerve injuries unknown.	Character of pain, especially exaggeration by emotional stimuli.	None.	2 relieved by repeated block.	do.	do.	Not performed.
McCloskey General Hospital (Maj. W. Tracy Haverfield, MC).	Less than 25; number of nerve injuries unknown (incidence not more than 1 percent).	Character of pain, especially exaggeration by light stimuli. Redness and excessive sweating.	do.	Majority relieved.	Occasional relief.	Occasional relief.	Majority relieved.
Hammond General Hospital and Birmingham General Hospital (Lt. Col. David L. Reeves, MC).	6; number of nerve injuries unknown (incidence not more than 1 or 2 percent).	As stated by S. Weir Mitchell.	do.	4 temporarily relieved (later operated on); 2 gradually improved with repeated blocks.	Not performed; 1 relieved by removal of neuroma in continuity.	Not performed.	Not performed.
Brooke General Hospital and McGuire General Hospital (Capt. Robert C. L. Robertson, MC).	Unknown (incidence very low).	do.	do.	Many relieved by several blocks, some by repeated blocks. Temporary relief only.	Incomplete relief of lower extremity pain in 1 case, probably because lumbar sympathectomy was incomplete. 1 operation, relief for 3 weeks, then return of symptoms. All relieved, 3 after second operation following incomplete primary operation.	Occasionally.	Few relieved had questionably complete lesions. 1 completely relieved.
Walter Reed General Hospital and Halloran General Hospital (Capt. Benjamin B. Whitcomb, MC).	Unknown.	Burning, tingling pain, aggravated by physical and emotional stimuli, incapacitatingly absorbing, relieved by procaine block without affecting sensory and motor fibers.	do.		Not performed.	Not performed.	

TABLE 12.—Data on causalgia obtained by postwar questionnaires to former medical officers in charge of neurosurgical centers of services—Continued

Hospital and neurosurgeon	Incidence	Criteria of diagnosis	Complete nerve injuries	Single or repeated blocks of sympathetic chain	Results of treatment		
					Complete sympathectomy	Neurolysis	Neurothaphy
Walter Reed General Hospital (Capt. Hugo V. Rizzoli, MC).	12 major (0.34 percent), 150 minor (4.29 percent) of 3,500 nerve injuries.	Partial nerve injury. Severe, excruciating, intermittent pain, aggravated by slightest contact, disturbance, or emotional reaction. Partial nerve injury. Less severe pain than above, usually relieved considerably by sympathetic block or sympathectomy.	None	Few cases of mild, minor causalgia relieved by repeated blocks.	2 not relieved by sympathectomy or other surgical procedures, including lobotomy. Both had very severe symptoms.	Not performed; temporary relief in some cases.	1 completely relieved (only such operation).
McCaw General Hospital (Maj. Francis A. Echlin, MC).	30 (2.0 percent) of 1,500 nerve injuries.	Time of onset. Characteristics and distribution of pain. Response to sympathetic block. Stiffness, sweating, skin changes.	3	1 patient relieved by single block, 2 by repeated blocks.	No relief in 2 cases, partial relief in 3.	Not performed	6 with severe lesions relieved, 4 improved, 2 not relieved. Usually unsuccessful.
14th Evacuation Hospital (China-Burma-India theater) (Maj. Theodore B. Rasmussen, MC).	107 (16.5 percent) of 650 nerve injuries.	Pain spontaneous or occurring soon after injury, and referred primarily to peripheral segment of limb. Persistence for more than few weeks, regardless of severity (neurotic and mechanical pain excluded). Trophic and vasomotor changes not considered.	2	13, all with mild symptoms, completely relieved within 1 month after 1 to 4 blocks. Some severe cases greatly benefited, none completely relieved.	7 of 21 patients previously operated on still had some pain on admission; 14 treated by Smithwick's procedure had complete relief. 5 had incomplete relief after excision of L2 and L3.	Partial relief in 15 cases. 1 relieved by ulnar neurolysis and excision of thrombosed segment of brachial artery.	

and may have included patients who, earlier in the war, would have recovered spontaneously while they were being held overseas.⁹

PATHOLOGIC PROCESS

Because causalgia notably occurs only with incomplete nerve lesions (p. 476), specimens were seldom available for pathologic examination. In the five such specimens studied at the Percy Jones General Hospital Neurosurgical Center, conventional stains revealed no appreciable differences between them and the neuromas secured from patients with nerve injuries without causalgia. Gross inspection at operation also revealed no significant

⁹This possibility has been interestingly discussed by Maj. Francis A. Echlin, MC, as follows: In a series of 1,500 peripheral nerve injuries treated at McCloskey General Hospital, Temple, Tex., in 1945, 30 patients (2 percent) suffered from major causalgia sufficiently intractable to require sympathectomy. Fifteen other patients, however, who had causalgia which was originally quite as severe did not require sympathectomy; they gradually improved under treatment by sympathetic blocks with procaine hydrochloride.

This observation suggested to Major Echlin and his associates that the incidence of causalgia at the various neurosurgical centers in the United States might be considerably higher than the currently reported statistics indicated. The explanation of the discrepancy, in their opinion, was the exclusion from these statistics of patients whose causalgia, as in their own patients, had improved or disappeared before they reached these centers.

To test this assumption, these observers examined and questioned 310 patients with nerve injuries who had not included or had not emphasized causalgia in their present complaints. They found that 61 (19.6 percent) had originally suffered from causalgia, which in most instances seemed to have been major. The course of the syndrome in most of the cases in which the diagnosis was made chiefly or entirely on the history was identical with that of the 15 patients with major causalgia who showed gradual improvement without sympathectomy while under observation at McCloskey General Hospital. All of them had suffered for periods of weeks to months with severe burning pain which, in time of onset, quality, severity and other characteristics, and distribution, was indistinguishable from the pain described by the patients with causalgia who had been cured by sympathectomy.

Of the 61 patients, 32 still had symptoms of mild or minor causalgia when they were examined. Gradual spontaneous improvement had occurred in the intense burning pain within 2½ months of the onset in 21 patients and within 6 months in 11 others. The pain had persisted, however, for more than 3 months in 31 patients and for more than 6 months in 10 others.

Major Echlin's observation that patients with major causalgia may improve without sympathectomy and that the incidence of this complication following war wounds is probably much higher than is usually reported is in keeping with the findings of Maj. (later Lt. Col.) Theodore B. Rasmussen (table 12). His incidence of 16.5 percent in 650 peripheral nerve injuries is probably explained by the fact that these patients, all of whom were treated in Burma, were seen soon after wounding.

It is interesting to note, Major Echlin pointed out, that S. Weir Mitchell also observed that spontaneous improvement is frequent in major causalgia. In his text entitled "Injuries of Nerves and Their Consequences," published in 1872, Mitchell wrote: "In 1867, Dr. W. W. Keen was kind enough to examine for me two of the worst of our former cases of causalgia. In both the injured parts were still a fraction of a degree warmer than those on the well side. Both of these men had improved considerably, and in both the pain had disappeared.

In the same text, Mitchell described the improvement in another case of major causalgia as follows: "* * * The burning pain slowly lessened without any therapeutic aid, and within 4 months of the date of wounding he [the patient] was well, excepting some tenderness and slight oedema of the foot."

Finally, Major Echlin noted that Mitchell's observations on blisters in causalgia indicate conclusively that the pain of causalgia commonly subsides without sympathectomy. Under this heading, Mitchell wrote as follows: "The curative treatment was simple. It consisted in blistering the burning part repeatedly with Granville's lotion or cantharides. * * * In light cases two or three blisters have answered; in others, ten or twelve have been needed, and, in very rare examples, this and every other method failed us, although such was never the case in any instance which was treated early, only the oldest cases being thus obstinate."

It is unfortunate, as Major Echlin said, that it is not possible to estimate the incidence of causalgia in Weir Mitchell's cases of nerve injury.—B. W.

differences. The osteoporosis observed in some of these patients (p. 478, and 485) could not be distinguished from the same process observed in patients with other nerve and bone diseases.

Capt. Byrl I. Kirklin, MC, and his associates were of the opinion, from clinical observation and the gross findings at operation, that causalgia was fairly frequent with complete nerve lesions. Microscopic examination of their specimens, however, revealed that all but two lesions were obviously incomplete, and, in these two, the pathologist regarded the findings as inconclusive.

ETIOLOGIC CONSIDERATIONS

Theories of Origin

Mitchell's¹⁰ statement in 1872 that the mechanism of causalgia was obscure is still generally true. A large number of theories have been advanced, but none of them is entirely satisfactory, and some of them can be eliminated immediately. One illustration is Leriche's¹¹ theory that the pain is due to ascending neuritis. Another is Tinel's¹² theory, advanced in 1919, that infection is a causative factor. The fact that the pain in many instances occurs almost immediately after wounding, as Mitchell and his associates¹³ noted during the Civil War, eliminates both of these theories from serious consideration. The theory of infection is particularly inapplicable to World War II cases, since, in most instances, healing occurred without gross infection. Lewis and Pickering's¹⁴ theory that the pain can be attributed to an accessory set of nerves, the so-called nocifensors, can also be eliminated; these nerves, which they postulated, have been found not to exist.

That neither ischemia nor hyperemia is responsible for causalgia is evident from two facts; (1) that vascular injury is infrequent in patients with causalgia and (2) that the subjective symptoms are the same, regardless of the blood flow through the extremity. Of the first 75 patients with causalgia observed at the Percy Jones General Hospital Neurosurgical Center during World War II, 40 were in vasodilatation and 35 in vasoconstriction, as shown by skin temperature studies of the entire group, supplemented by oscillometric studies of the first 15 patients observed. Those in vasodilatation usually showed skin temperature readings from 1° to 4° F. higher than readings of corresponding areas of the normal extremities; those in vasoconstriction showed readings from 2° to 6° F. lower.

¹⁰ Mitchell, S. Weir: *Injuries of Nerves and Their Consequences*. Philadelphia: J. B. Lippincott Co., 1872.

¹¹ Leriche, René: *The Surgery of Pain*, translated and edited by Archibald Young. London: Ballière, Tindall and Cox, 1939.

¹² Tinel, J.: *Parathésies précoces après suture on greffe nerveuse*. *Rev. neurol.* 26: 521-526, 5 June 1919.

¹³ See footnote 1, p. 469.

¹⁴ Lewis, T., and Pickering, G. W.: *Vasodilatation in the Limbs in Response to Warming the Body, With Evidence for Sympathetic Vasodilator Nerves in Man*. *Heart* 11: 33-51, 7 Oct. 1931.

Subjective symptoms were identical in both groups. Interruption of the sympathetic chain was successful in relieving the pain whether vasodilatation or vasoconstriction was present. It would therefore seem that alterations in the blood flow in the affected limb can be excluded as a cause of the pain.

None of the patients at Percy Jones General Hospital were observed for more than 2 months before sympathectomy, but it is probably significant that, during the period of observation, there was no change in the vasomotor state in any instance. In all of the cases observed by White, Heroy, and Goodman¹⁵ in a naval hospital, the painful extremity was in vasoconstriction, which led them to suggest that the brief duration of the condition might explain the vasodilatation reported by other observers. This theory was not borne out by the cases studied at Percy Jones General Hospital.

In 1943, on the basis of their laboratory experiments, Granit and his associates¹⁶ advanced the view that causalgia might result from cross-stimulation of sensory fibers as the result of interaction of these fibers with the sympathetics within the injured nerve. In 1944, Doupe and his associates¹⁷ published clinical studies which supported this premise, which was additionally supported by White and his group. Most of the well-documented reports from Army neurosurgical centers in World War II also supported it, although some data were not compatible with it. These conflicts seemed to stem from two causes, differences in diagnostic criteria and variable interpretations of the term "minor causalgia" (p. 477). Another explanation of the discrepancies was the tendency of some observers to overemphasize features of the disorder which are different while discounting the overwhelming similarity of features common to all cases.

Analysis of data available from various reports on causalgia reveal certain significant points, as follows:

1. The disease nearly always results from a penetrating wound of a large mixed nerve. The incidence is considerably higher in the median and the sciatic nerves, an observation of importance in view of the high proportion of sympathetic and sensory fibers in these nerves.
2. The nerve injury, with very occasional exceptions, is incomplete.
3. The pain is usually exaggerated by emotional and environmental stimuli (p. 479 and 482), which are known to cause increases in the efferent impulses flowing from the hypothalamus over the sympathetic chain. This point is strongly emphasized by White, Heroy, and Goodman.
4. The pain is reduced by agents which reduce the outflow of efferent stimuli from the hypothalamus, such as cold in hyperemia, heat in ischemia, sleep, and certain drugs. Interruption of the sympathetic chain provides

¹⁵ White, J. C., Heroy, W. W., and Goodman, E. N.: Causalgia Following Gunshot Injuries of Nerves: Role of Emotional Stimuli and Surgical Cure Through Interruption of Diencephalic Efferent Discharge by Sympathectomy. *Ann. Surg.* 128: 161-183, August 1948.

¹⁶ Granit, R., Leksell, L., and Skoglund, C. R.: Fibre Interaction in Injured or Compressed Region of Nerve. *Brain* 67: 125-140, June 1944.

¹⁷ Doupe, J., Cullen, C. H., and Chance, G. Q.: Post-Traumatic Pain and the Causalgia Syndrome. *J. Neurol. Neurosurg. & Psychiat.* 7: 33-48, January-April 1944.

complete relief. Excision of the injured segment, which in effect converts the incomplete to a complete lesion, is similarly effective.

The work of Granit, Leksell, and Skoglung, published in 1944, showed that there is a constant interaction of impulses between various nerve fibers, and that the sensitivity to this interaction, particularly when sensory fibers are involved, is greatly increased when the nerve is injured. These data lend strong support to the view expressed by these observers and by Doupe and his associates to the effect that the pathologic mechanism of causalgia is a shunting or short circuiting of impulses from the sympathetic into the sensory fibers of the injured nerve. It would seem, therefore, if symptoms take the form of burning superficial pain and hyperesthesia, that portions of the distal segment of the nerve must be viable and must reach their normal sensory end organ, as can happen when the nerve injury is partial, as it practically always is. When this situation exists, the sensory end organs are bombarded with impulses of frequency and amplitude which they are not normally destined to receive.

The weak point in the theory advanced is obvious. If causalgia can arise from a short circuiting of impulses, surely it could occur with complete as well as incomplete lesions. There is general agreement, however, that it is most common in patients with incomplete lesions. Furthermore, unless some specific difference exists between complete and incomplete lesions, one would expect causalgia to occur far more frequently in amputations than it apparently occurs. The possibility must be considered that retrograde degeneration of the axis cylinder with transection of a nerve may set up conditions unfavorable to the interaction of impulses.

Many observers have never encountered causalgia in complete nerve injuries. In two instances at Percy Jones General Hospital in which the surgeon, on gross inspection, interpreted the lesion as complete, it was later proved to be incomplete by sensory and electrical examination; these studies showed that both sensory and motor fibers of which the surgeon was not aware had been divided by him at operation.

An instance of causalgia in a complete nerve lesion was, however, observed by Lt. Col. Barnes Woodhall, MC, at the neurosurgical center at Walter Reed General Hospital, Washington, D.C.:

A 24-year-old tank captain dated the onset of burning pain in his upper arm to the fourth day after injury, when he first became cognizant of his surroundings. There was no doubt that this was a major causalgia; it fulfilled at the criteria (p. 485). The arm was amputated at the upper third of the humerus shortly afterward, because of impending gangrene; the amputation was done just below the elbow, above the original point of nerve injury. As soon as the patient reacted from anesthesia, it was found that causalgia was still present. Immediate relief was obtained by sympathetic block and complete relief by sympathectomy; in fact, the patient was caught

walking down the hall the day after operation (early ambulation was not permitted in World War II).

This patient was seen by Dr. James C. White of Boston while his symptoms were at the maximum. Dr. White agreed that this was an instance of true causalgia in an amputated arm with a phantom limb. During the period of pain, it was impossible to touch or examine the patient. After relief of pain by sympathectomy, he disclaimed any interest in the phantom limb, which was represented only by a lightly clenched fist in the intact arm hanging at his side. This man had had four battle injuries and had been decorated for bravery on two occasions, and he tried hard to get back into active duty after the last operation.

Therapeutic Correlations

It is difficult to reconcile a number of observations with the theory just advanced to explain the mechanism of pain in causalgia. One is the report by Tinel that block of the nerve proximal to the site of injury failed to provide relief of pain, which was, however, secured by section distal to the injury. Doupe and his associates speculate that the relief which follows injection of the nerve distal to the site of injury means that the site of interaction is distal to the site of injury, often in the most distal part of the extremity; failure to provide relief, on the other hand, by injection of the nerve distal to the site of injury indicates that the site of interaction is at the site of injury. The instances of failure to secure relief by section or injection of the nerve proximal to the site of injury are too infrequent to carry much weight. It is likely that they can be explained by technical errors (p. 490).

It is possible that the spontaneous recoveries which sometimes occur in causalgia can be explained by the redeposit of myelin at the areas in which it has been fragmented.¹⁸ Such a process might also account for the relief secured by patients who undergo repeated injections of the nerve over long periods. It cannot, however, explain the cases in which there is permanent relief of severe pain by a single injection of procaine into the sympathetic chain.

Other Painful Posttraumatic Dystrophies

Homans,¹⁹ Herrmann and his associates,²⁰ and Tinel take the position that most painful posttraumatic dystrophies, such as Sudeck's atrophy and painful osteoporoses, as well as painful phantom limb and the so-called

¹⁸ Denny-Brown, D., and Brenner, C.: The Effect of Percussion of Nerve. *J. Neurol. Neurosurg. & Psychiat.* 7: 76-95, July-October 1944.

¹⁹ Homans, J.: Minor Causalgia: A Hyperesthetic Neurovascular Syndrome. *New England J. Med.* 222: 870-874, 23 May 1940.

²⁰ Herrmann, L. G., Reineke, H. G., and Caldwell, J. A.: Post-Traumatic Painful Osteoporosis: A Clinical and Roentgenological Entity. *Am. J. Roentgenol.* 47: 353-361, March 1942.

minor causalgias, are all different manifestations of the same underlying disorder. When Homans introduced the term "minor causalgia," he evidently intended it to apply to patients who were suffering from such conditions as Sudeck's atrophy. A few medical officers, however, applied the term to patients with true causalgia resulting from penetrating wounds. Most medical officers who worked in neurosurgical centers believed that causalgia must be regarded as a clinical entity which may arise from the same pain mechanisms as certain minor causalgias, using the term in the generally accepted sense. Painful phantom limb and the psychoneuroses have a different origin.

The mechanism just postulated to explain causalgia leads to conjectures concerning the mechanism in Sudeck's atrophy and painful osteoporosis. If these are, indeed, different clinical manifestations of the same underlying disorder, a possible explanation is that, in the latter conditions, the injury is to smaller nerves which supply tendons and ligaments. When shunting of impulses occurs, the pain is then expressed as an aching sensation rather than as burning hyperesthesia, as in causalgia, in which the more superficial sensory organs are involved.

There is no doubt that, correctly, painful phantom limb and causalgia must be considered as separate entities. More than 3,000 amputees were admitted to the amputation center at Percy Jones General Hospital. The first 200 were studied carefully from the standpoint of possible phantom limb. In the remaining admissions, all patients who developed painful phantom limb were studied on the neurosurgical wards. The incidence immediately after amputation was extremely high, probably 50 to 60 percent of all cases. Pain subsided rapidly, however, and few casualties were left with permanent residuals of painful phantom limb. From this study, it was concluded that painful phantom limb is not a surgical problem, except for the excision of locally painful scars and neuromas that interfere with weight bearing and the application of prostheses. The transient relief which followed chemical block of the sympathetic chain in a few cases was interpreted as the result of suggestion and not as evidence that sympathectomy would be followed by permanent relief.

SYMPTOMS AND SIGNS

The description of causalgia by Mitchell, Morehouse, and Keen, based on their observations of nerve injuries during the Civil War, is an unsurpassed example of clinical description. They wrote, in part, as follows:

The seat of burning pain is very various, but it never attacks the trunk, rarely the arm or thigh, and not often the forearm or leg. Its favorite site is the foot or hand * * *.

The great mass of sufferers described this pain as superficial, but others said that it was also in the joints, and deep in the palm. If it lasted long, it was referred finally to the skin alone.

Its intensity varies from the most trivial burning to a state of torture, which hardly

can be credited, but which reacts on the whole economy, until the general health is seriously affected.

The part itself is not alone subject to an intense burning sensation, but becomes exquisitely hyperaesthetic, so that a touch or a tap of the finger increases the pain. Exposure to the air is avoided by the patient with a care which seems absurd, and most of the bad cases keep the hand constantly wet, finding relief in the moisture rather than the coldness of the application * * *.

Later, in 1872, Mitchell wrote as follows:

Perhaps few persons who are not physicians can realize the influence which long continued and unendurable pain may have on both body and mind. Under such torments the temper changes, the most amiable grow irritable, the bravest soldier becomes a coward, and the strongest man is scarcely less nervous than the most hysterical girl. Nothing can better illustrate the extent to which these statements may be true than the cases of burning pain, or, as I prefer to term it, causalgia, the most terrible of all tortures which a nerve wound may inflict.

Symptoms

The cardinal symptom of causalgia was always burning pain, sometimes throbbing, sometimes aching, but, in the experience of most observers, always burning. On the other hand, a few reliable observers stated that some of their patients did not interpret the pain as burning, and it may be that this adjective has been somewhat overworked; it is significant that patients who experienced the minor variety of causalgia never used the term. Some patients felt as if their hands were being "squeezed in a vise." Others said they felt as if the flesh of the affected part were "being torn off." Whatever the description, there was little doubt of the severity of the pain in patients suffering from major causalgias. In no instance did there seem any correlation at all between the severity of the nerve injury and the intensity of the causalgia.

Mitchell, Morehouse, and Keen stated that some of their patients complained of pain almost as soon as the injury occurred. In most instances in World War II, the onset of the pain was delayed, sometimes for several weeks.

The pain was always referred to the distal portion of the affected limb and was usually more intense in the autonomous zone of the injured nerve, though it was not necessarily limited to it. The hands and feet were most frequently affected. In the hand, the pain was referred chiefly to the palm and the fingers. In the foot, it was referred chiefly to the instep, sole, and toes.

The pain was always continuous but was not always of the same severity. Extreme hyperesthesia of the involved part was characteristic of the more severe cases. Equally characteristically, the pain was subject to exacerbation by the slightest emotional or physical stimulus. Many times, jarring of the bed, slamming of the door, even a draft of cool air, might induce severe paroxysms. The patients appeared to be in a perpetual state of defense

against such stimuli. Some went to almost absurd extremes to protect the injured part (fig. 218). They would grasp the painful limb just proximal to the wrist or ankle and hold the protective posture for long periods of time, even for hours. Meantime, the facial expression usually reflected intense suffering.



FIGURE 218.—Patient with causalgia. Note facial expression. He is protecting the painful member by holding it immobilized with the other hand.

Some patients learned to protect the part with makeshift coverings of soft cloth (fig. 219). Others, as Mitchell had observed, found comfort in the application of moisture to the part, including the simple expedient of carrying a tumbler of water in the painful hand. Some patients overseas stated that they filled their boots with water to accomplish the same end. The majority preferred that the water be cold, but a few stated that they were more comfortable when it was hot.

At Percy Jones General Hospital, after a number of patients had made the observation that they were relieved by the application of moisture, the response to this measure became a routine test for causalgic patients. Sixty-eight of the 75 who were surveyed for the preparation of this chapter obtained some relief. Thirty-eight preferred cold applications, and 30 preferred warm. In several instances, the application of moist towels provided relief for the first time, after weeks of continuous suffering. The change in facial expression was remarkable (fig. 220), and the patients were almost dramatically surprised that limbs which had heretofore been untouchable because of pain could be touched and even moved without discomfort.

Objective Findings

Patients with causalgia were often malnourished because their food intake was low. The facial expression, as already mentioned, usually reflected intense suffering, anxiety, and weariness.

Trophic and vasomotor changes were commonly observed in patients who had severe pain. These changes were less striking when pain was of lesser intensity. In severe cases, the changes occurred early.

Vasomotor and trophic changes were of two types; vasodilatation and vasoconstriction. In vasodilatation, the temperature of the skin was usually 2° to 6° higher than that of the unaffected member (fig. 221). The skin was dry and scaly (fig. 222). The hair was long and coarse, and the nails were



FIGURE 219.—Makeshift covering of dry flannel, worn constantly to protect causalgic member.

thick and ridged. In vasoconstriction, on the contrary, the skin was colder by 2° to 5° F. than the skin of the opposite member (fig. 223) and was thin and sometimes denuded. Often it was wet, glistening, and mottled (fig. 224). The involved parts were likely to be hairless, and the fingers were thick and tapering. In general, patients in vasodilatation found relief from cold applications, while those in vasoconstriction preferred heat. Two patients in vasoconstriction who were observed during attacks of malaria (*Plasmodium vivax*) with intermittent chills were free from pain during the temperature elevations, the pain returning soon after the fever subsided (p. 487).

Trophic changes were generally similar to those observed in comparable nerve injuries without causalgia.

Stiffness of the joints, particularly the small joints of the hands and feet, was frequently excessive, but it was often more reasonably attributable to disuse than to any specific reaction to the painful process. Splinting had often been both incorrect and of unnecessarily long duration.

It was usually difficult to appraise the degree of motor paralysis because of the unwillingness of the patients to permit a complete examination. Upon relief of pain, many showed surprising degrees of recovery, sometimes within a few seconds, the observation suggesting that there might be, at least in part, a reflex paralysis of considerable degree of the type described by Livingston.

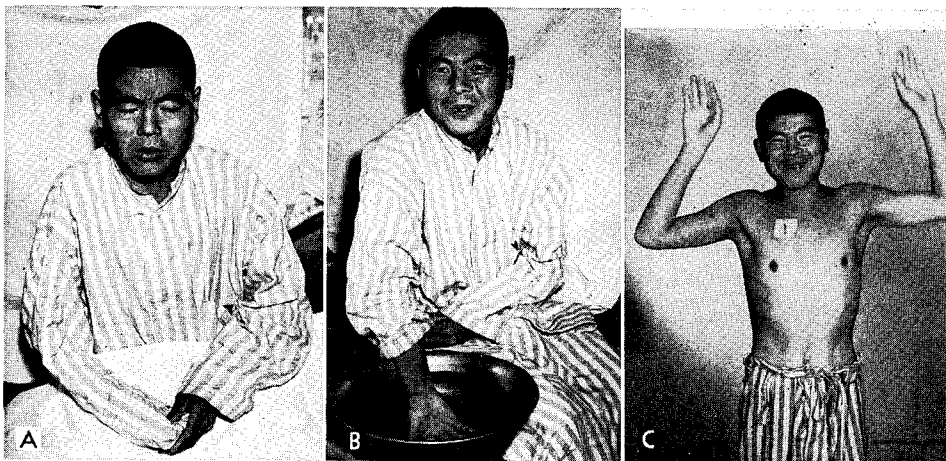

FIGURE 220.—Serial photographs of patient with causalgia showing extreme suffering, mode of relief, and complete freedom from pain. A. Painful right hand protected by sleeve of pajamas. Note facial expression. B. Relief of pain with immersion of hand in cold water. Note change in facial expression. C. Appearance of patient with causalgia after sympathectomy. Note unrestricted movement of hand and change in facial expression.

Capt. (later Maj.) Elmer C. Schultz, MC, reported that many of the patients observed at the 55th General Hospital, Malvern, England, presented contractures of the muscles. A characteristic deformity of the median nerve, which often permitted diagnosis at a glance, was hyperextension of the second and third digits, which bent dorsally.

Sensory losses were as difficult to determine as motor paralysis because of the extreme hyperesthesia. Usually, it was possible to determine only which nerve was involved and that the lesion was incomplete.

Psychogenic Factors

The disturbed emotional state of patients with causalgia was always striking. Though most of them had been stable, valiant soldiers until their injury, they were many times emotional derelicts afterward. They were irritable and shut in. They were critical of attendants and found fault with them captiously. They had no interest in family and friends, even though they had been overseas for many months.

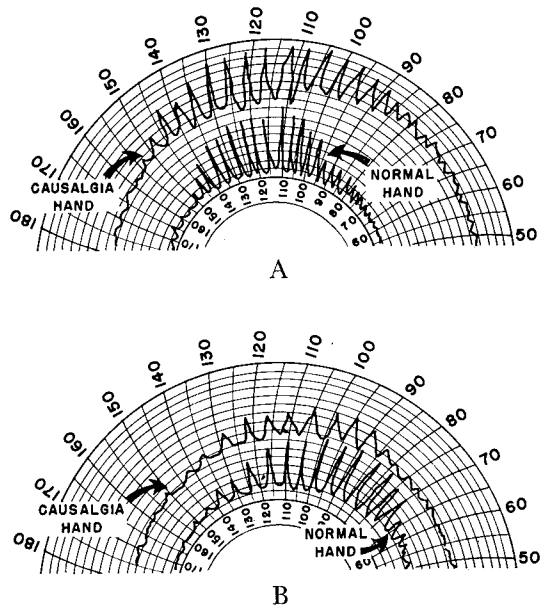

FIGURE 221.—Oscillometric tracings in causalgia of right hand caused by injury of median nerve. A. Tracings on admission. The skin temperature of the affected hand at this time was 37.5° C. and of the normal hand 36.2° C. B. Tracings after preganglionic dorsal sympathectomy. The skin temperature of the affected hand at this time was 35.4° C. and of the normal hand 30° C.



AFIP HA-728-1

FIGURE 222.—Causalgic hand after median nerve injury. Note dry, scaly skin in the nerve distribution.

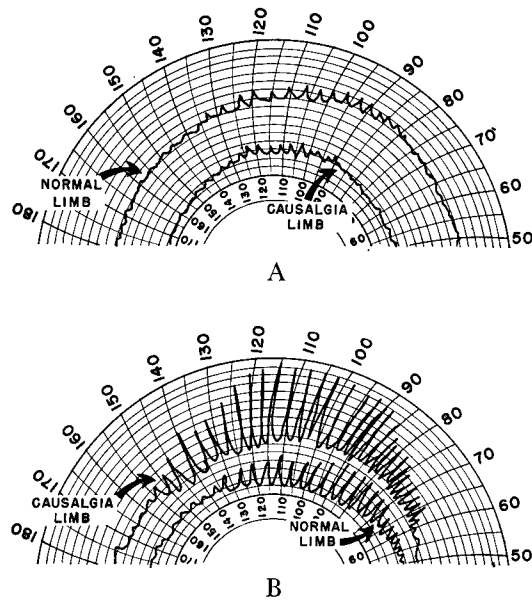

FIGURE 223.—Oscillometric tracings in causalgia of left foot caused by injury of sciatic nerve. A. Tracings on admission. The skin temperature of the affected foot at this time was 31° C. and of the normal foot 35° C. B. Tracings after lumbar sympathectomy. The skin temperature of the affected foot at this time was 37.9° C. and of the normal foot 33.6° C.



FIGURE 224.—Method devised by patient with causalgia to keep hand constantly wet.

Fear, anger, and other emotional stimuli disturbed and distressed them. Sudden noises, lighting the room without warning, tearing paper, dragging a chair across the floor, shaking the bed, or an attempt at examination of the painful part set off such paroxysms of pain that some patients not only reviled their attendants and physicians but even struck them. Many were affected by sounds which recalled harrowing wartime experiences. One recalled a boat whistle. Another tried to wreck a dressing cart because the squeak of the wheels reminded him of the squeaking hinges of the door of his cabin on the ship on which he had gone overseas. One was particularly disturbed by the high notes of the bugle call. White, Heroy, and Goodman described patients whose pain was increased by drinking cold water, witnessing exciting moving pictures, and the act of urination or defecation.

Many patients with causalgia were unjustly classified as malingerers or hysterical. Practically all of them, however, promptly recovered their emotional stability after relief of pain, and those subjected to psychiatric survey afterward, in neurosurgical centers, showed no constitutional psychogenic factors.

At the 55th General Hospital, many of the 63 patients with causalgia observed over a 6-month period were found to have presented manifestations of emotional instability before their injuries. These manifestations included excessive worry; easy excitability; frequent headaches; cold, sweaty hands and feet; and diarrhea after minor emotional stresses. Many of them also admitted to a low pain threshold. These observations are contrary to the usual experience in patients with causalgia.

Roentgenologic Observations

In 20 of the patients with causalgia observed at the neurosurgical center, Percy Jones General Hospital, roentgenologic examination showed spotty osteoporosis (fig. 225), somewhat more marked in those in vasodilatation. The demineralization, however, was no more pronounced than it was in patients with comparable nerve injuries who did not complain of causalgia.

DIFFERENTIAL DIAGNOSIS

Causalgia must be distinguished from a number of other painful post-traumatic states in which burning pain is sometimes a complaint. The diagnosis of causalgia was therefore regarded as justified in most neurosurgical centers only when the following criteria were met:

1. The pain occurred in an extremity which was the site of a peripheral nerve injury which practically always was incomplete.
2. The pain was always of a burning character.
3. The pain was extremely severe and was exaggerated, often to a paroxysmal degree, by environmental and emotional stimuli.
4. The pain was associated with certain vasomotor and trophic changes (p. 481) and often with personality changes (p. 482).

5. The pain was temporarily relieved by procaine hydrochloride injection of the sympathetic chain and was permanently relieved by sympathectomy.

Pain associated with neuromas, bony injury, and traumatic arthritis was of a different quality from causalgic pain. Causalgic pain apparently occupies a much higher level of consciousness, and an experienced observer was never in doubt of the organic origin and the extent of suffering of a patient with it. He constantly protected himself from painful stimuli. Patients with other conditions would frequently demand relief, but they would accept delay quietly, even placidly. The patient with causalgia would not tolerate delay.

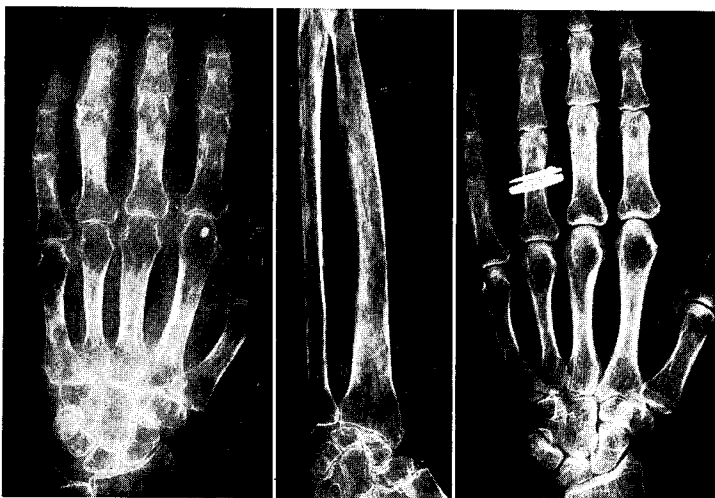

FIGURE 225.—Roentgenograms showing spotty osteoporosis in causalgic limb.

The pain associated with Sudeck's atrophy or painful osteoporosis lacked the burning character of causalgic pain. It usually occurred in the deep soft tissues about the smaller joints. The pain complained of in phantom limb occurred under different circumstances, beginning with complete nerve section. The pain of hysterical subjects and malingerers also had special characteristics.

Therapeutic test.—In doubtful cases, the therapeutic test of sympathetic block was of great value. In the general experience, relief thus secured seldom exceeded the expected physiologic effect of the drug. Although there were numerous reports of permanent relief from a single injection, the most experienced observers came to believe that when this occurred, the patient's complaints were likely to be psychogenic and not of organic origin. A number of these patients complained of burning pain which was not influenced by emotional and environmental stimuli, as is characteristic of causalgia. Some of them presented evidences of vasoconstriction. They obtained prolonged relief by sympathetic block, contrary to the experience of those with

causalgia, but were relieved only transiently or not at all by subsequent sympathectomy; some of them, after the operation, complained of added pain around the surgical wound. Some patients who underwent sympathectomy for painful phantom limb had the same experience.²¹

MANAGEMENT

The wartime experience indicated that no measure except surgery could be expected to provide permanent relief in causalgia. Symptomatic measures could obviously not be continued for any length of time because of the very real danger of drug addiction.

At Percy Jones General Hospital, after the observations made on patients with malaria (p. 481), artificial fever therapy was tested on five patients. One remained well after three treatments, but the other four, all of whom were eventually completely relieved by sympathectomy, had relief only during the period of elevated temperature.

At the neurosurgical center at Kennedy General Hospital, Memphis, Tenn., as well as at other centers, lysis of the affected nerve did not produce relief in a single case. At this same center, another patient with burning pain in the distribution of the radial nerve was apparently cured by repeated doses of papaverine hydrochloride for 2 days, but similar treatment in other cases produced no results.

At the 55th General Hospital, this same method was used in mild causalgias; subcutaneous injections (gr. one-third to one-half) were given several times daily for several days. It was thought that the improvement in the capillary blood flow accounted for whatever relief was secured. In a few other cases of mild causalgia treated at the same hospital, local injection of the cutaneous nerves of the hand or foot with 1-percent Novocain solution afforded gradual and increased relief with each injection; treatment could be discontinued permanently after three or four injections had been given.

Though plans of management differed in the different neurosurgical centers, as has just been indicated, there was rather general agreement that patients suffering from causalgia of any appreciable degree should be treated

²¹The writer of this chapter has observed only one patient with true causalgia who was not completely relieved of pain by sympathectomy. This patient, encountered in civilian practice, was a 55-year-old white woman who had the symptom for 3 years after traumatic amputation of the fingers. She was addicted to morphine when she was first seen. She had complete relief for 4 days after sympathectomy. Then the pain began to return and soon reached its maximum intensity. Psychiatric interview under thiopental sodium (Pentothal sodium) revealed that the patient's complaint of pain stemmed from her desire for morphine as well as for industrial compensation for her injury.

There does not seem justification, in spite of this and similar cases, for the rather general belief that patients with causalgia arising from civilian accidents which entail damage suits or industrial compensation do less well than patients observed in military practice. In both military and civilian practice, of course, long continued pain may lead to emotional instability, including drug addiction, incompatible with industrial usefulness. Similarly, desire for compensation may lead to malingering, but these motivations are the results, not the causes, of true causalgia.

first by procaine hydrochloride injection of the sympathetic chain for diagnostic purposes. If relief was more than temporary, additional injections were given, to the number of three or four. If relief was not permanent, as it most usually was not, it was the general practice to perform sympathectomy, and, as a rule, to perform it promptly.

At the Percy Jones center, early in the war, some patients were injected as many as eight times without permanent relief; in the later months of the war, this procedure was employed only for diagnostic purposes.

In some centers, only patients with severe pain were considered candidates for prompt sympathectomy, on the ground that in the less severe cases the pain would subside spontaneously. This did happen, in a fair percentage of cases. According to Maj. Francis A. Echlin, MC, 16.6 percent of the patients with causalgia admitted to McCaw General Hospital, Walla Walla, Wash., had recovered before the first examination. There is, however, no assurance of spontaneous recovery in any case, while in favor of prompt sympathectomy is the sound argument that even if recovery should occur, it may be so long delayed that the crippling effects of prolonged disuse of the extremity and the psychic trauma of prolonged pain would be devastating. The risk of the operation and its side effects are so slight, when the procedure is performed by an experienced neurosurgeon, that they are completely outweighed by the hazards of delayed treatment.

When the nerve lesion was sufficiently severe to warrant excision of the injured segment, the substitution of this operation for sympathectomy gave good results. Periarterial neurectomy at the level of the injury was never successful. Records of the neurosurgical centers reveal no instance in which periarterial neurectomy of the more proximal portions of the vessels was carried out by Leriche's technique. This does not seem a logical procedure, in view of the fact that no fibers are believed to traverse the periarterial sheath which do not also pass through the ganglionated chain.

Technique of Sympathectomy

The techniques employed at Army neurosurgical centers for both paravertebral block and subsequent removal of portions of the sympathetic chain followed the practices of the individual surgeons. As a rule, pre-ganglionic dorsal sympathectomy was done by the posterior approach through the muscle-splitting incision developed by Smithwick.

In the later operations at Percy Jones General Hospital, precautions originally taken for preventing regeneration of the sympathetic chain, including avulsion of the intercostal nerves and encasement of the proximal stump with impervious material, were abandoned. It was believed that the painful lesion would be corrected before regeneration occurred; apparently this happened.

While a few surgeons approached the lumbar sympathetic chain transperitoneally, the majority accomplished exposure of the chain through a unilateral retroperitoneal approach by means of the muscle-splitting incision described by Shumacker. Others used a modification of the kidney incision, which transects the muscles of the flank.

To denervate the arm, the rami connecting the second and third dorsal ganglia were divided, and the chain was sectioned below the third dorsal ganglia. In cases handled early in the war, this portion of the chain was left in situ. In later cases, the second and third dorsal ganglia were removed.

In the lumbar region, removal of the second and third lumbar ganglia was usually sufficient to denervate the leg. At times, however, it was necessary to remove the 11th and 12th thoracic ganglia as well, in order to denervate the lower extremity satisfactorily.

RESULTS

There are few reliable followup statistics on patients with causalgia, whether treated or untreated. John K. Mitchell's²² report on his father's patients showed that some of them were still suffering from the condition 20 years after their injuries. Pollock and Davis reported persistent pain for 2 years or more.

Procaine injection of the appropriate sympathetic ganglia almost invariably gave immediate and dramatic relief of pain for periods ranging from 1 to 3 hours. In a few instances, partial relief persisted for several days, but, as a rule, the pain again reached maximum intensity within a short time. During the period of remission, the patient became cooperative, and a more thorough sensory and motor evaluation of the involved part was possible. Frequently, in cases in which no motor function had previously been observed, the patient began to move the painful extremity immediately, which suggested that in some cases, at least, the pain had initiated a reflex paralysis.

Doupe,²³ White,²⁴ and their associates also observed partial relief of pain for several days after sympathetic block. At Schick General Hospital, Clinton, Iowa, permanent relief of pain was reported in some cases after single or repeated blocks, and some similar results have been reported by civilian observers.²⁵ The reliability of the sources makes it impossible to challenge these results, but, equally, they cannot be explained. In the Percy Jones General Hospital, the only patients who showed any persistent improvement after single or repeated sympathetic blocks were those who had been in the most extreme pain, and their relief was relative, not absolute. One patient

²² Mitchell, John K.: *Remote Consequences of Injuries of Nerves and Their Treatment. An Examination of the Present Condition of Wounds Received 1863-65, With Additional Illustrative Cases.* Philadelphia: Lea Bros. & Co., 1895.

²³ See footnote 17, p. 475.

²⁴ See footnote 15, p. 475.

²⁵ (1) See footnote 17, p. 475. (2) De-Takats, G.: *Causalgie States in Peace and War.* J.A.M.A. 128: 699-704, 7 July 1945.

admitted to this center required sympathectomy for recurrent pain after he had been discharged from another center as cured after procaine injection. This was probably not the only case of the kind in World War II.

All of the patients treated surgically at the Percy Jones General Hospital were followed up for at least 6 months after operation. During that period, none of them had any recurrence of pain as is evident in the tabulated histories of the first 60 patients treated at this center (table 13). The total series numbered 105 patients.

Of the first 72 treated surgically, 24 answered questionnaires about their condition from 3 to 5 years after operation. Fifteen of the 24 were still free of persistent pain, but 14 complained of slight aching pain in the extremity when they became fatigued. Many were still conscious of tingling, numbness, or weakness in the affected limb. This was to be anticipated. Sympathectomy cannot be expected to relieve these manifestations of nerve injury, and, if the burning pain is relieved, the operation should not be interpreted as a failure.

An analysis of nine cases in which some pain persisted after sympathectomy showed that, in every instance, the sympathectomy had been incomplete. In two cases in which the upper extremity was involved, the fourth rib had been removed instead of the third. In one instance, completion of the sympathectomy produced complete relief, and, in the other, the symptoms, although still present, had been so much improved that the patient did not wish further surgery.

In the seven instances in which the lower extremity was involved, the second and third lumbar ganglion had been removed in all cases, and the fourth lumbar ganglion, in addition, in some cases. Sweat tests showed that sweating was preserved in certain areas of the involved extremity, and injection of the more proximal portion of the chain provided complete relief of pain.

When the first lumbar ganglion was later removed in all seven of these cases, three patients had permanent relief. In the four cases in which pain was persistent after removal of the entire lumbar chain at the second operation, injection of the lower thoracic chain (D_{10} , D_{11} , and D_{12}) with procaine afforded relief of pain in the lower extremity and abolished excessive sweating. Complete relief was later secured by removal of the 10th, 11th, and 12th thoracic ganglia. Removal of D_{12} or of D_{11} and D_{12} might also have afforded relief, but the magnitude of the necessary procedures did not seem justified.

It seems highly probable that most instances of failure after sympathectomy can be explained as the failures just recorded were explained; that is, by incomplete sympathectomy caused by inadvertent removal of the wrong rib when the arm was involved or by anomalous innervation of the leg when the lower extremity was involved.

TABLE 13.—Essential data in 60 cases of causalgia, Percy Jones General Hospital Neurosurgical Center, Battle Creek, Mich.¹

Case number	Age (years)	Wounding agent, location of wound, nerves involved	Onset of pain	Duration (months)	Relief by moisture	Management	Result
1	22	Bullet, left wrist, median nerve	24 hours	7	Cold	Sympathectomy, preganglionic, D ₂ , D ₃	Relief
2	20	Shell fragment, left leg, tibial, peroneal nerves	Immediately	4½	do.	Sympathectomy, L ₂ , L ₃	Do.
3	22	Bullet, left buttock, sciatic nerve	2 weeks	5½	do.	Sympathectomy, L ₁ , L ₂ , L ₃	Do.
4	36	Shell fragment, right thigh, sciatic nerve	Immediately	1½	do.	Sympathectomy, L ₂ , L ₃	Do.
5	34	Shell fragment, left arm, median, ulnar, radial nerves	4 days	5	do.	Sympathectomy, preganglionic, D ₂ , D ₃	Do.
6	24	Shell fragment, left buttock, sciatic nerve	Immediately	6	Warm	Sympathectomy, L ₁ , L ₂ , L ₃ , L ₄	Do.
7	26	do.	do.	3	do.	Sympathectomy, L ₁ , L ₂ , L ₃ , L ₄ , D ₁₁ , D ₁₂	Do.
8	30	Shell fragment, right thigh, sciatic nerve	do.	6½	do.	Sympathectomy, L ₂ , L ₃	Do.
9	28	do.	do.	2½	do.	Sympathectomy, L ₂ , L ₃ , L ₄	Do.
10	27	Bullet, left arm, median nerve	do.	5	do.	Sympathectomy, preganglionic, D ₂ , D ₃	Do.
11	26	Shell fragment, left side of neck, brachial plexus	24 hours	5¼	do.	do.	Do.
12	27	Shell fragment, right arm, median nerve	48 hours	7¾	do.	do.	Do.
13	22	Shell fragment, right thigh, sciatic nerve	24 hours	5¾	do.	Sympathectomy, L ₂ , L ₃	Do.
14	23	Shell fragment, left forearm, median, ulnar nerves	Immediately	4¼	do.	Sympathectomy, preganglionic, D ₂ , D ₃	Do.
15	22	Shell fragment, left leg, tibial nerve	do.	2	do.	Sympathectomy, L ₂ , L ₃	Do.
16	31	Bullet, left arm, median nerve	2 weeks	6	do.	Sympathectomy, preganglionic, D ₂ , D ₃	Do.
17	31	Shell fragment, right thigh, sciatic nerve	Immediately	3½	Cold	Sympathectomy, L ₂ , L ₃	Do.
18	23	Shell fragment, right buttock, sciatic nerve	do.	5	Warm	Sympathectomy, L ₁ , L ₂ , L ₃	Do.
19	20	Shell fragment, right thigh, sciatic nerve	do.	4	do.	Sympathectomy, L ₂ , L ₃	Do.
20	22	Shell fragment, left leg, tibial, peroneal nerves	48 hours	1½	Cold	do.	Do.
21	31	Shell fragment, left axilla, brachial plexus	6 weeks	3½	Warm	Sympathectomy, preganglionic, D ₂ , D ₃	Do.
22	23	Shell fragment, left thigh, sciatic nerve	Immediately	4	Cold	Sympathectomy, L ₂ , L ₃	Do.
23	19	Shell fragment, right thigh, sciatic nerve	2 weeks	3¾	do.	do.	Do.
24	28	Shell fragment, right forearm, median, ulnar nerves	Immediately	2½	Warm	Sympathectomy, preganglionic, D ₂ , D ₃	Do.
25	29	Bullet, left axilla, brachial plexus	2 weeks	4¼	Cold	do.	Do.
26	36	Shell fragment, left forearm, median nerve	Immediately	1	Warm	Sympathectomy, preganglionic, D ₂ , D ₃	Do.
27	31	Bullet, left side of neck, brachial plexus	do.	3	do.	Later, neurolysis C ₈ and D ₁ roots.	Do.
28	26	Bullet, right thigh, sciatic nerve	do.	1¾	Cold	Sympathectomy, L ₂ , L ₃ , L ₄	Do.
29	26	Shell fragment, left axilla, brachial plexus	do.	15	Warm	Sympathectomy, preganglionic, D ₂ , D ₃	Do.
30	37	Bullet, right axilla, brachial plexus	do.	4	Cold	do.	Do.
31	26	Shell fragment, left arm, median nerve	do.	2	do.	do.	Do.

See footnote at end of table.

TABLE 13.—Essential data in 60 cases of causalgia, Percy Jones General Hospital Neurosurgical Center, Battle Creek, Mich.¹—Continued

Case number	Age (years)	Wounding agent, location of wound, nerves involved	Onset of pain	Duration (months)	Relief by moisture	Management	Result
32	19	Shell fragment, left axilla, median, ulnar nerves.	Immediately	3½	Cold	Sympathectomy, preganglionic, D ₃ , D ₄	Relief.
33	21	Shell fragment, left arm, median, ulnar nerves.	48 hours	5	do	do	Do.
34	20	Shell fragment, left thigh, sciatic nerve.	Immediately	3½	do	Sympathectomy, L ₂ , I ₃	Do.
35	28	Bullet, left arm, median nerve.	48 hours	6½	None	Sympathectomy, preganglionic, D ₂ , D ₃	Do.
36	37	Shell fragment, right thigh, sciatic nerve.	4 days	7	Warm	Sympathectomy, L ₁ , I ₂ , I ₃	Do.
37	21	Shell fragment, left arm, median nerve.	Immediately	8	do	Sympathectomy, preganglionic, D ₂ , D ₃	Do.
38	33	Shell fragment, right side of neck, brachial plexus.	48 hours	6	Cold	do	Do.
39	21	Bullet, right thigh, sciatic nerve.	Immediately	2	do	Neuroorrhaphy	Do.
40	24	Bullet, left thigh, sciatic nerve.	do	3	Warm	do	Do.
41	25	Bullet, left forearm, median, radial nerves.	do	5	do	Sympathectomy, preganglionic, D ₂ , D ₃	Do.
42	26	Shell fragment, right axilla, brachial plexus.	do	3½	do	do	Do.
43	30	Bullet, left arm, median, radial, ulnar nerves.	do	2	do	do	Do.
44	23	Shell fragment, right buttock, sciatic nerve.	2 weeks	2½	Cold	Sympathectomy, L ₁ , L ₂ , L ₃ , I ₄ , D ₁₁ , D ₁₂	Do.
45	33	Shell fragment, right axilla, brachial plexus.	1 week	4	do	Sympathectomy, preganglionic, D ₂ , D ₃	Do.
46	23	Bullet, left axilla, brachial plexus.	Immediately	3	do	do	Do.
47	20	Bullet, right thigh, femoral nerve.	do	6½	do	Sympathectomy, L ₁ , L ₂ , L ₃ , I ₄	Do.
48	33	Shell fragment, right arm, median, ulnar, radial nerves.	do	6½	do	Sympathectomy, preganglionic, D ₂ , D ₃	Do.
49	24	Shell fragment, left arm, median, ulnar nerves.	do	3½	None	do	Do.
50	39	Shell fragment, right axilla, median nerve.	do	3	Warm	do	Do.
51	25	Shell fragment, left thigh, sciatic nerve.	3 days	5	Cold	Sympathectomy, L ₁ , I ₂ , I ₃	Do.
52	25	Bullet, left thigh, sciatic nerve.	4 days	1¼	do	do	Do.
53	24	Shell fragment, left thigh, sciatic nerve.	1 week	1¼	do	do	Do.
54	26	Bullet, left axilla, brachial plexus.	Immediately	3	do	do	Do.
55	30	Bullet, right thigh, sciatic nerve.	2 months	3½	None	Sympathectomy, preganglionic, D ₂ , D ₃	Do.
56	28	Shell fragment, right thigh, sciatic nerve.	2 weeks	2¼	Warm	Sympathectomy, I ₁ , I ₂ , I ₃ , I ₄	Do.
57	29	Shell fragment, right axilla, brachial plexus.	16 hours	2½	Cold	Sympathectomy, L ₁ , I ₂ , I ₃	Do.
58	20	Shell fragment, right arm, median, ulnar nerves.	Immediately	5¼	Warm	Sympathectomy, preganglionic, D ₂ , D ₃	Do.
59	23	Bullet, left axilla, median, ulnar nerves.	24 hours	2½	None	do	Do.
60	21	Shell fragment, right leg, tibial nerve.	48 hours	1	Cold	Sympathectomy, I ₂ , I ₃ , I ₄	Do.

¹ In all, 105 patients with causalgia were observed at this center. The data in the other 45 cases were essentially the same as in these cases, which were the first to be observed.

CHAPTER XX

Peripheral Nerve Grafts

*Frank E. Nulsen, M.D., Frederic H. Lewey, M.D., and
William P. Van Wagenen, M.D.*

GENERAL CONSIDERATIONS

As casualties accumulated in World War II, it promptly became evident, as it had been evident in previous wars, that the enormous number of wounds of the extremities produced by high-velocity missiles would result in many instances of damage to long segments of peripheral nerves. The first estimates were that about 5 percent of all nerve divisions incurred in combat might be irreparable by the usual measures of mobilization and suture. As this situation came to pass, the possibilities of nerve grafting were once again seriously considered.

The World War I experience with nerve grafts had not been particularly promising, and little work had been done in this field between the wars. The type of nerve injuries encountered in civilian life seldom require a consideration of this technique, which is admittedly a last-resort procedure. Isolated successes with homogenous nerve grafts have been reported in human subjects, it is true. On the other hand, surgeons who have had experience in the early assessment of results after nerve grafting have remained properly skeptical about them; the reports of success are usually vaguely documented, and it is generally realized that improvement in the function of an extremity is more likely to be due to compensatory factors than to nerve regeneration.

That definite and useful regeneration can follow the use of autogenous nerve grafts after certain injuries has been demonstrated by such observers as Ballance and Duell¹ in repair of the facial nerve and by Bunnell² and Seddon³ in the repair of digital nerves. Excellent results in the repair of digital nerves were obtained by many surgeons during World War II; reports of these successes are well documented. Some remarkable results in autogenous grafting of the facial nerve were reported by Lathrop.⁴ It is

¹ Ballance, C., and Duell, A.: The Operative Treatment of Facial Palsy by the Introduction of Nerve Grafts into the Fallopian Canal and by Other Intratemporal Methods. *Arch. Otolaryng.* 15: 1-70, January 1932.

² Bunnell, Sterling: *Surgery of the Hand*. Philadelphia: J. B. Lippincott Co., 1944.

³ (1) Seddon, H. J.: Peripheral Nerve Injuries. *Glasgow M. J.* 139: 61-75, March 1943.
(2) Seddon, H. J. (editor): *Peripheral Nerve Injuries*. Medical Research Council Special Report Series No. 282. London: Her Majesty's Stationery Office, 1954.

⁴ Lathrop, Frank D.: Facial Paralysis in Military Personnel. *In* Medical Department, United States Army. *Surgery in World War II*. Ophthalmology and Otolaryngology. Washington: U.S. Government Printing Office, 1957, pp. 525-548.

also well established that cross suturing is often successful; a centrally divided facial nerve for instance, may be supplied with substitution innervation from the hypoglossal or the spinal accessory nerve trunk.

A careful distinction must be made, however, between the use of autogenous grafts in injuries of these relatively small nerves and the homogenous grafting of the extensive combat-caused nerve deficits of major peripheral nerves considered in this chapter. The techniques just described were not applicable to the vast majority of the injuries of such major nerve trunks as the median, ulnar, radial, tibial, and peroneal nerves which were encountered in World War II.

In extensive deficits in these nerves, it is impossible to find a comparable nerve trunk for sacrifice for grafting purposes in the same patient without imposing upon him an additional serious functional deficit. It was only occasionally that irretrievable damage to another extremity permitted use of one of its nerve trunks as a graft or that the loss of the fourth or fifth fingers associated with extensive damage to the median nerve permitted the use of the ulnar nerve in an attempt to restore all-important median nerve function. Autografts of this kind have sometimes been satisfactory, especially when the ulnar nerve has been employed as a pedicle to maintain the ulnar blood supply, but these opportunities seldom arise.

Theoretically, it would seem possible that a long length of a dispensable sensory nerve, such as the saphenous or the lateral femoral cutaneous nerve, might be cut into shorter lengths and the lengths laid side by side as a bridging cable graft to overcome a defect in a major nerve trunk. This technique has been employed satisfactorily in grafts of the digital and facial nerves, and occasional successes have been reported following its use in other areas. When, however, one considers that the cross section of this type of cable graft consists of perhaps 10 percent nerve tubules and 90 percent connective tissue and interstices between filaments, the success of such a bridge seems unlikely, even as a theoretical possibility.

DEVELOPMENT OF THE PROGRAM

The first attempts at homogenous nerve grafting in World War II centered around the use of fresh nerves obtained from patients who had undergone amputation; these circumstances permitted the immediate use of the graft under aseptic conditions. Seddon and Holmes⁵ in England and Spurling and the group working with him at Walter Reed General Hospital, Washington, D.C., all employed this technique. By 1944, however, it had become apparent that none of their patients were showing physiologic signs of regeneration, and, on later histologic study, it was found that the best regeneration had never proceeded more than 20 mm. into the proximal end of the graft and that its extent even at this level was scanty.

⁵ Seddon, H. J., and Holmes, W.: The Late Condition of Nerve Homografts in Man. *Surg. Gynec. & Obst.* 79: 342-351, October 1944.

The consistent failure of homogenous nerve grafts and the success reported by Weiss⁶ and his associates in the use of frozen dried homografts in animals led to an extensive trial of this method in man. Hope that this inert material might serve better than fresh grafts for nerve regeneration was based on the theory that inert material would not continue to undergo metabolic changes and necrosis and thus would not promote the degree of foreign-body or inflammatory reaction which occurred with fresh homografts.

The results of 20 frozen dried homografts used by Lyons and Woodhall at Walter Reed General Hospital did not bear out this hope.⁷ With a single exception,⁸ the results, whether full-thickness grafts were used or grafts consisting of many separate fascicular cables, were comparable to the results obtained with fresh homografts, in that only the most proximal portion of the graft became neurotized.

The results in the 26 similar grafts employed at the Cushing General Hospital Neurosurgical Center, Framingham, Mass., and reported in this chapter were equally discouraging. Skepticism concerning their possible value might have developed earlier except for two reasons. The first was the long delay inevitable between the placement of a graft and the evaluation of its capacity for permitting regeneration. The second was the hope, which proved vain, that repeated alterations in technique, which were regarded as improvements, might improve the results in the later cases of the series.

MATERIALS AND METHODS

In the 11-month period after this program was transferred from Walter Reed General Hospital to Cushing General Hospital in August 1944, 26 frozen dehydrated homogenous nerve grafts were employed in 21 patients. Of the injuries, 5 were incomplete and 21 were complete.

All the grafts were obtained from autopsies conducted at Boston City Hospital and Peter Bent Brigham Hospital, Boston, Mass., both of which kindly cooperated in the program. Cadavers were utilized for this purpose only when the following criteria were met:

1. Autopsy could be performed within 4 hours of death.
2. Infection and chronic malnutrition had played no obvious part in the fatality.
3. The patients were young men or were relatively young.

The nerves were removed under conditions of absolute sterility. The blood group of the donor was rechecked. Separate cultures were made from the heart blood and the donor site as an additional safeguard against pos-

⁶ Weiss, P.: Experiments on Nerve Repair. *Tr. Am. Neurol. A.* 1943, pp. 42-45.

⁷ The results in these cases are discussed in the followup study of World War II peripheral nerve injuries undertaken by the Veterans' Administration, the Army and Navy, and the National Research Council (p. 230).

⁸ Although this patient was operated on while the program was in progress at Walter Reed General Hospital, he is included in this series because most of his followup period was spent at the Cushing General Hospital Neurosurgical Center and because he had a later evaluation in 1949 by one of the authors of this chapter (F. E. N.). He is included in this series as case 1 (p. 500).

sible bacterial contamination. Other cultures were made at various stages of preparation of the grafts, and any batch in which bacterial growth occurred was discarded.

The material was prepared according to the technique of Weiss and Taylor,⁹ by quick freezing in sterile isopentane cooled by liquid nitrogen to -175° C. The frozen grafts were then dehydrated in vacuo, at a temperature between -30° and -40° C., in sterile tubes, which could be sealed when drying had been completed. Each tube was plainly marked with the autopsy source and the blood group of the donor and was stored in an antiseptic solution with other tubes until it was used.

When it was decided, during an operative procedure, to bridge a defect between nerve ends by grafting, a tube containing material of the appropriate blood group was obtained. In the first cases at Cushing General Hospital, rehydration was accomplished by breaking the vacuum tube in Ringer's solution. Later, after histologic study of resected grafts, it was found that serum rehydration produced less distortion than rehydration accomplished by Ringer's solution, water, saline solution, or spinal fluid. The patient's own serum was therefore utilized in most of the later cases to accomplish rehydration.

INDICATIONS

Frozen dehydrated homogenous nerve grafts were used on the following indications:

1. When the extent of the defect seemed to make direct suture impossible.
2. When direct suture could not be accomplished without tension on the suture line. In some cases, in which the defect was less extensive than in the group of injuries just mentioned, suture seemed technically possible after the employment of extensive mobilization of the nerve trunk or after such radical measures as bone shortening. In many of these cases, however, it was thought that the degree of tension on the suture line would be so considerable that physiologic regeneration and functional recovery would be unlikely to parallel the anatomic feat of approximation and suture.
3. When the slack necessary for overcoming a defect between nerve ends could not be obtained because of fixation of a joint, as, for example, fixation of the knee in full extension.
4. When mobilization of nerve trunks could not be accomplished without extension of the necessary dissection to areas of damaged skin and soft tissue in patients with multiple points of injury.
5. When the injuries involved the median or ulnar nerve at the wrist or the tibial nerve at the ankle to such an extent that direct suture could be accomplished easily only if mobilization were carried above the elbow or the knee. There was frank concern over how such extensive handling of long

⁹ Weiss, P., and Taylor, A. C.: Guides for Nerve Regeneration Across Gaps. *J. Neurosurg.* 3: 375-389, September 1946.

lengths of nerve, with consequent impoverishment of the blood supply, might influence regeneration. In these circumstances, the necessary grafts were relatively short, and it was hoped that a relatively short graft might behave more favorably than a long graft. Finally, in this area, the means for early recognition of failure was at hand, since the distance for growth to skin and muscle was short. If failure occurred, therefore, there could be a prompt resort to the more extensive mobilization procedure which would permit direct suture.

6. When damage to a nerve trunk, although incomplete, was so extensive that nearly half of the cross section of the nerve seemed implicated in stony-hard scar tissue which was so sharply delineated, at least grossly, that the balance of the nerve seemed intact and capable of regeneration. In some cases of this kind, the lesion involved a long segment of the nerve, and it did not appear technically feasible, after the affected portion had been resected, to approximate the portion in discontinuity. A graft was therefore inlaid when it seemed that more might be lost than gained by sacrificing the segment in continuity in order to accomplish full-thickness resection and suture. The graft was considered the best expedient for the patient but was undertaken with the full realization of the difficulty of attributing any part of whatever recovery might occur to regeneration through the graft.

TECHNIQUE

Evolution of Surgical Methods

The first 15 grafts employed at Cushing General Hospital (this number including the graft used in the patient operated on at Walter Reed General Hospital) were obtained from the sciatic nerve. In the first of these cases, fascicles of large caliber were used, of such a size that two or three thicknesses corresponded to the defective areas in the recipient nerve trunks. In later cases in which the sciatic nerve was used, it was broken down into increasingly small filaments before processing, so that from 5 to 10 strands were needed to match the size of the recipient nerve trunks.

Evidence suggested that these finer filaments fared better from the standpoint of both vascularization and neurotization, and the material for the last 11 of the 26 grafts in the series therefore consisted of the anterior roots of cauda equina, which were secured by laminectomy in the cadaver. If smaller filaments were preferable, as it was thought they were, these roots were ready at hand and were free of the large connective tissue septa found in peripheral nerve tissue. It was also thought that the uniformly large tubules of these motor roots would afford a better bridge for axonal regeneration than the scattered large and small tubules of the sensory roots.

The technique of placement of the grafts underwent a number of modifications, as follows:

1. In the cases which were handled during the first 3 months of the program at Cushing General Hospital, a tantalum sleeve was employed to encompass the entire graft and the resected nerve ends for 5 to 10 mm. At the end of this period, when the first reexplorations were conducted because of obvious failures, it was found that, although good union of the proximal nerve ends and grafts had occurred, the major portion of the grafts, which had been insulated from any circumferential vascular supply, had a totally inert appearance. The gross observations were confirmed by histologic study.

2. When these observations were made at the second operation, it was also observed that the tantalum sleeve had created a cylindrical cavity of fibrous tissue, within which fresh grafts could be easily approximated to the freshened nerve ends and held in place by closure of the cavity with sutures. In two of the early failures, regrafting was carried out in this fashion at the end of 3 months.

3. In other cases, a two-stage procedure was employed. At the first operation, a cavity was prepared to enclose the graft, by connecting the nerve ends with an empty tantalum sleeve. From 4 to 6 weeks later, the sleeve was removed, and the cavity which had been formed by it was utilized to hold a cable graft in continuity with the freshened nerve ends.

4. In still other cases, after the technique of complete insulation by the tantalum sleeve had been abandoned, the grafts were enclosed in collagen sleeves as an alternative to the two-stage procedure.

5. In one instance, the graft was approximated to the nerve ends with narrow tantalum bands, leaving its major portion exposed to the surrounding tissue.

6. Toward the end of the program it was learned that the plasma glue technique of Tarlov¹⁰ was being used routinely at St. Alban's Naval Hospital in New York as a method for nerve-end approximation. This technique permits the application of many nerve filaments, in good approximation, to the face of large nerves, without resort to cuffs or sleeves, in instances in which cable grafts are used and suture is not technically feasible. This method was used in only one instance in this series (case 16, p. 501) to patch grafts onto facial nerve filaments. The results were remarkably good.

7. All five partial nerve defects were filled in with graft inlays.

Postoperative Management

After operation, the injured extremity was immobilized in plaster for 3 to 4 weeks, as in the usual nerve repair. Small marking wires placed on the sheaths of the nerve ends were repeatedly visualized by roentgenograms, to be certain that the ends did not become widely separated during subsequent mobilization of the joint.

¹⁰ Tarlov, I. M.: Plasma Clot Suture of Nerve—Illustrated Technique. *Surgery* 15: 257-269, February 1944.

EVALUATION OF RESULTS

Incomplete Injuries

All of the five partial nerve defects filled in with graft inlays (table 14) showed clear clinical evidence of varying degrees of regeneration. Three of these grafts were reexposed when the tantalum sleeve was removed. At this time, the graft could not be distinguished from the intact nerve, but electrical stimulation applied to the inlaid nerve elements produced no sensation. No method was available to determine what part the graft may have played in the regeneration which was evident in all of these cases.

TABLE 14.—Results of use of frozen dried homografts in 5 partial peripheral nerve defects

Case number	Nerve	Location of injury	Timelag, injury to grafting	Timelag, insertion to removal	Size of graft	Gross observations at reexploration	Clinical result
17-----	Tibial-----	Mid thigh...	<i>Months</i> 2	<i>Months</i> 13	3.5 cm., $\frac{2}{3}$ cross section.	White, insensitive.	Low-grade sensation.
18-----	do-----	Ankle-----	5	13	2.5 cm., $\frac{1}{2}$ cross section.	Pink, sensitive....	Fair sensation, no motor recovery.
19-----	Ulnar-----	Wrist-----	3	14	3 cm., $\frac{1}{2}$ cross section.	do-----	Good sensation, fair motor recovery.
20-----	do-----	Forearm....	3	-----	2.4 cm., $\frac{1}{2}$ cross section.	-----	Better than average recovery.
21-----	Peroneal....	Mid thigh...	10	-----	4.5 cm., $\frac{1}{3}$ cross section.	-----	Minimal recovery.

¹ Tantalum cuff removed.

Complete Injuries

When nerve grafts were applied to complete defects, the problem of evaluation was simpler. A fair test of the potentials for nerve regeneration would have covered many months if clinical evidence had been awaited, and the policy, therefore, was to reexplore the injury within 3 to 4 months on the suspicion of failure. The basis of the suspicion was the absence of Tinel's sign just below the graft and the absence of paresthesias when the same point was stimulated electrically with needles introduced percutaneously.

At operation, the graft was removed for microscopic study unless, in addition to perception of paresthesias when the exposed graft was stimulated electrically, there was gross evidence of some vascularization and viability. When slight neurotization had occurred, as was subsequently demonstrated histologically in the grafts removed, its extent was found to be closely paralleled by the extent of the sensitivity of the graft to stimulation. Suture by radical measures was usually possible in these cases, and the specimen for study included the graft with the attached proximal and distal nerve stumps.

Some grafts which proved to be failures were left in place longer than was generally thought desirable because of apparent signs of regeneration, which later proved to be misleading. Methods used to prove that regeneration had occurred unequivocally through grafts to complete nerve defects are best described by the following case histories:

Case 1.—This patient, who was operated on at Walter Reed General Hospital by Maj. Benjamin B. Whitcomb, MC, sustained a perforating wound of the left distal forearm, with severance of the median nerve and a compound fracture of the radius. Because of infection, operation on the nerve was not undertaken until 11 months later, in June 1944. A proximal neuroma of the median nerve was found in minimal continuity with a bulbous distal nerve. Stimulation of the neuroma gave rise to paresthesias referred to the median sensory zone.

The neuronal continuity was considered inadequate for function. The nerve ends were therefore resected until grossly normal nerve tissue was obtained, the gap thus created being 7 cm. By employing the degree of partial wrist flexion which the bone injury permitted, plus the use of two tantalum stay sutures, the nerve ends could be brought within 3 cm. of each other. This gap was filled with a full-thickness frozen dried homograft from the sciatic nerve. The graft was anchored to the proximal and distal ends by two sutures at each end. The graft and the nerve ends were wrapped in a cylindrical sleeve of tantalum foil.

Six months later, in December 1944, the area was reexplored, to remove the tantalum sleeve and examine the graft. Although the graft was narrowed in the central portion, it appeared to be vascularized. The occurrence of paresthesias in the median area on stimulation of the distal nerve indicated that some neurotization had occurred through the graft into the distal nerve. Although there was no evidence of useful regeneration at this time, it was decided to leave the graft in place for an additional period of observation.

Three months later, this patient was transferred to Cushing General Hospital, with a warning that the staff should not be misled by the scanty evidences of regeneration through a graft which, if left in situ, was probably destined to give less adequate regeneration than might be obtained with its removal and extensive nerve mobilization and direct suture.

Fifteen months after insertion of the graft proximal to the wrist, evidences of median nerve function were unequivocal. Sensory examination revealed that 40 gm. pain stimulus and 16 gm. touch stimulus could be felt throughout the median area. When the area of the graft was infiltrated with procaine hydrochloride, and while ulnar and radial sensation were intact, this sensation was absent in the two terminal phalanges of the index and long fingers. Conversely, nerve blocks which were undertaken as a separate maneuver and which produced total sensory loss in the radial and ulnar areas were without effect upon pain and touch perception in the median autonomous zone.

Sweating was assessed by skin resistance, as a further test of skin innervation. The median area became dry when the graft was blocked. Later, it showed 80 percent of normal sweating. Sweating in the median area was either unaltered or even increased by the discomfort attendant upon total combined radial and ulnar blocks.

When motor function was tested, observers were agreed that the *opponens pollicis* contracted during attempted thumb opposition and that slight rotation of the thumb was evident. This component of thumb movement was lost when the graft was blocked.

The most convincing evidence of regeneration was afforded by electrical stimulation delivered to two needles inserted in the vicinity of the graft; a definite contraction could be seen in the *opponens pollicis* and was sufficient to roll the thumb over from its relaxed position to a point opposite the middle finger. This movement was recorded cinemat-



FIGURE 226.—Successful use of frozen dried homograft by plasma glue technique in injury of right facial nerve at mastoid tip. The pictures were taken 8 months after operation. A. Face in repose. B. Face on smiling.

ographically. When the test was repeated on several occasions, it was therefore possible to accept this evidence of an increasing volume of movement response, in spite of the skepticism among the observers.

This patient was observed in October 1949, under the auspices of the peripheral nerve regeneration study project supported by the Veterans' Administration, the National Research Council, and the Army and Navy (p. 230). At this time, his sensory thresholds in the median autonomous zone were 2 gm. for pain and 2 gm. for touch; occasional points required 10 gm. of stimulus. Median nerve block abolished this sensation, while radial and ulnar nerve blocks did not affect it.

Thumb opposition was rated at 25 percent of normal. The movement was produced by median stimulation; ulnar stimulation produced only flexion. The patient could pick up small objects blindly between his thumb and the tips of any of the last three fingers. Impaired flexion of the index finger and the tip of the thumb were residuals of tendon involvement.

The median motor and sensory functions were rated at a level close to the average found after median nerve suture at the wrist and above the average when suture had been delayed, as in this instance, for 11 months after injury.

Case 16.—This graft, the last of the complete nerve severances in the series, was carried out 4 months after the facial nerve had been injured at the mastoid tip. The central end was found at operation, as were two distal filaments corresponding to the inferior and middle facial branches. Two filaments of cauda equina were attached to the central end with plasma glue. One of these filaments was glued to the middle branch for a length of 4 cm. and the other to the inferior branch for a distance of 1 cm. The grafts were left exposed to the tissues, which had been freely dissected.

Within 4 months, this patient began to show action at the angle of his mouth, and, at the end of another 4 months, there was function in all of the lower facial musculature up to the level of the orbicularis oculi. Needle stimulation of the facial nerve behind the mandible reproduced the movements initiated voluntarily by the patient. The amplitude of action in the lower face, as well as the cosmetic result, was fully as satisfactory as is usually seen after suture (fig. 226). Complete paralysis of the upper ocular musculature and of the forehead persisted because it was impossible to find a satisfactory superior branch for inclusion in the graft.

RESULTS

The two case histories just related represent the only two successes in 23 attempts to use frozen dried homografts to bridge complete nerve defects. The remaining 16 cases, all of which ended in failure, are most conveniently analyzed according to the procedures employed (table 15).

TABLE 15.—Results of use of frozen dried homografts in complete peripheral nerve defects in 16 cases (21 operations)

Surgical techniques	Nerve	Location of injury	Timelag, injury to grafting	Timelag, insertion to removal	Length of graft	Findings at reexploration	
						Gross	Histologic
Tantalum sleeve technique:			<i>Months</i>	<i>Months</i>	<i>Cm.</i>		
Case 1.....	Median.....	Wrist.....	11		3	Vascularized, sensitive.	Left in situ, regeneration.
Case 2 ¹	do.....	do.....	3	2.5	3.5	Proximal 5 mm. pink and sensitive.	Slight neurotization and vascularization for 5 mm.
Case 3.....	Ulnar.....	do.....	2	5	5.2	Proximal 10 mm. pink but insensitive.	Vascularization for 1 cm., questionable neurotization.
Case 4 ¹	do.....	do.....	4	2.5	5.5	Totally avascular, insensitive.	No vascularization or neurotization.
Case 5.....	do.....	do.....	3	4	2	Shrunken, avascular, insensitive.	Marked sterile inflammatory reaction; slight neurotization and vascularization for 7 mm.
Case 6.....	do.....	Forearm..	3	2	10	Necrotic, grossly infected.	Inflammation, necrosis.
Case 7 ¹	Tibial.....	Calf.....	3	4	5	Totally avascular, insensitive.	No vascularization or neurotization.
Case 8.....	Radial.....	Axilla.....	5	6	3.5	Yellow, insensitive.	No tissue reaction.
Case 9.....	Median.....	Forearm..	4	3	6	Necrotic, grossly infected.	Inflammation, necrosis.
Exposure technique:							
Case 10 ¹	Ulnar.....	Upper arm.	9	2.5	6.5	Yellow, insensitive in toto.	Vascularization and resorption; neurotization for 2 mm.
Case 4 ²	do.....	Wrist.....	7	11	7	Pink and sensitive for 26 mm.	Vascularization, resorption; slight neurotization at periphery.
Case 2 ²	Median.....	do.....	5.5	9	5	Avascular, but slightly sensitive throughout.	Minimal neurotization extending to distal-nerve.
Collagen sleeve technique:							
Case 10 ²	Ulnar.....	Upper arm.	11.5	5	9.5	Totally insensitive and inert.	Most of graft resorbed; neurotization for 2 mm.
Case 10 ³	Median.....	do.....	11.5	5	10.5	Shrunken, fibrosed, insensitive.	Neurotization for 3 mm.
Case 11.....	do.....	Forearm..	8	5	10.5	Fibrosed, insensitive.	Graft largely resorbed; one nerve bundle invaded for 5 mm.

See footnotes at end of table.

TABLE 15.—Results of use of frozen dried homografts in complete peripheral nerve defects in 16 cases (21 operations)—Continued

Surgical techniques	Nerve	Location of injury	Timelag, injury to grafting	Timelag, insertion to removal	Length of graft	Findings at reexploration	
						Gross	Histologic
Collagen sleeve technique—Continued Case 7 ²	Tibial	Calf	Months 7	Months 9	Cm. 8	Largely inert but slightly sensitive.	Severe fibrotic change; minimal neurotization for 5 cm.
Prepared bed technique: Case 12	do	do	8		5	Not reexplored.	
Case 13	Median	Forearm	10	9	4	Yellow, shrunken, insensitive.	Slight vascularization, no neurotization.
Case 14	do	Wrist	6	8	5	Pink, sensitive throughout, slight contraction in opponens.	Slight neurotization throughout.
Case 15	Peroneal	Above knee	12	7	3	Shrunken, inert, insensitive.	Not removed. No clinical recovery at 1 year.
Plasma glue technique: Case 16	Facial	Mastoid tip	4		4 and 1	Not reexplored, obvious clinical signs of regeneration at 4 months.	

¹ First operation. ² Second operation. ³ Third operation.

Tantalum Sleeve Technique

The technique employed in case 1 was generally followed in eight other cases (table 15, cases 2 through 9). Either large or small fascicles obtained from the sciatic nerve were enclosed, together with the nerve ends, in a tantalum sleeve except that, in most cases, the nerve ends were sutured to the surrounding tissues rather than joined with wire stay sutures. The defects bridged ranged from 2 to 10 cm. The time interval from injury to grafting was more favorable in all the other cases than in case 1, but all the other eight grafts were unequivocal failures.

There are various explanations for the failures. In cases 6 and 9, gross infection ensued. In case 2, the median nerve lesion was in many respects similar to the lesion in case 1. When the graft was reexamined at the end of 2½ months, after dissection of the tantalum sleeve, it was found firmly attached to the nerve ends, with some bulbous enlargement at the proximal junction. Except for the proximal 5 mm., most of the graft had either a cadaveric appearance or the same gross appearance as when it was introduced. The proximal area was pink, and stimulation limited to it produced median paresthesia. More distally, both the graft and the distal nerve were insensitive to electrical stimuli.

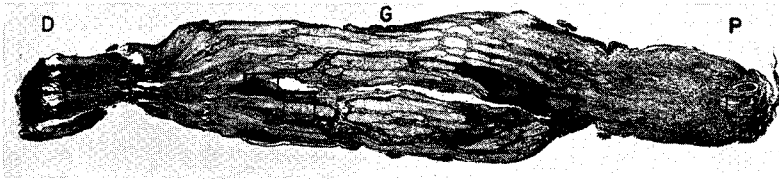

FIGURE 227.—Successful use of frozen dried homograft by tantalum sleeve technique in injury of median nerve at wrist. Note that the central portion of the graft retains its initial appearance. D, distal end of graft. P, proximal end. G, graft occupying central portion.

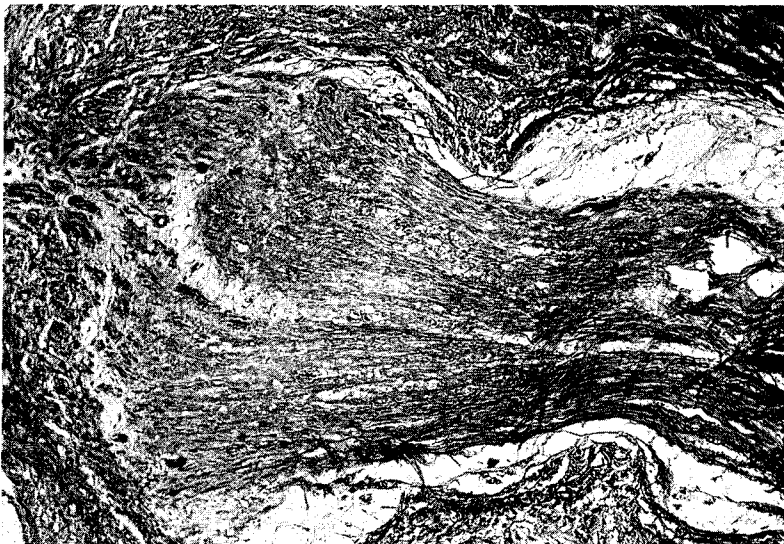

FIGURE 228.—Successful use of frozen dried homograft by tantalum sleeve technique in injury of median nerve at wrist. This photomicrograph shows the best portion of the proximal nerve, well removed from the graft. There is considerable fibrosis, with a minimum of amyelinic fibers losing their direction in their progression toward the graft at the left.

The graft was removed en bloc, with short lengths of proximal and distal nerve ends. The histologic appearance of the graft in case 2 (figs. 227, 228, 229, and 230) may be summarized as follows:

1. In spite of good attachments of the graft at each end, vascularization and organization were limited to a short zone, within 6 mm. of the nerve junctions. More centrally, cadaveric preservation rather than necrosis was evident.

2. The proximal nerve end consisted chiefly of connective tissue with a paucity of axons, which were chiefly unmyelinated in any given area. It was thought that this finding could reflect inadequate resection of the scarred

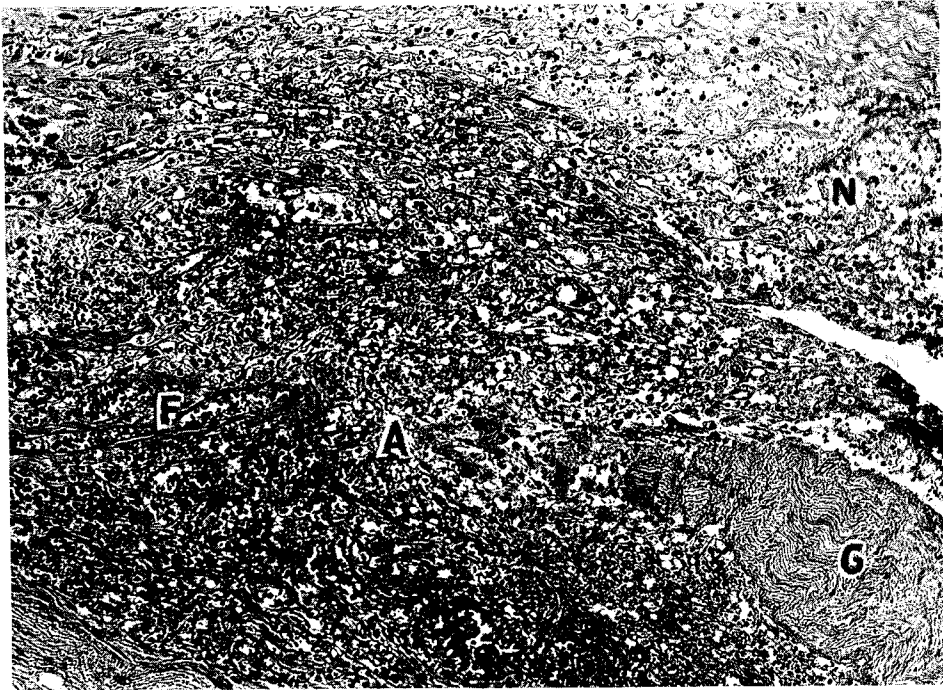

FIGURE 229.—Successful use of frozen dried homograft by tantalum sleeve technique in injury of median nerve at wrist. The graft shows colligation necrosis (N) but preservation of fibroblasts and sheaths of Schwann (A and F). Unattacked but dead graft bundles are also present (G).

nerve end, though the frequency of similar observations throughout the series suggested that the opposed graft might induce inflammation and fibrosis in the nerve end.

3. A few amyelinic nerve fibers penetrated the graft for 3 to 5 mm., as had been suggested by the sensory findings when the graft was stimulated, but they were dishearteningly few in number, and they chose to drill their way into the dense connective tissue of the perineurium rather than to seek out the tubules of the nerve graft intended to attract them.

The case just described might be classified as a not quite complete failure. More typical of the complete rejection of the graft as a vehicle for axonal ingrowth was the histologic appearance of the graft in case 4 (figs. 231, 232, and 233). This graft appeared to have induced the proximal nerve end to wall itself off with a fibrotic cap which permitted absolutely no neurotization of the graft itself. There was much less vascularization of the graft at its ends than in case 2, while the largest (central) portion apparently remained insulated from any tissue reaction at all.

The wide differences in behavior in the grafts in the cases handled by the tantalum sleeve technique (cases 1, 2, and 4, for instance) cannot reason-

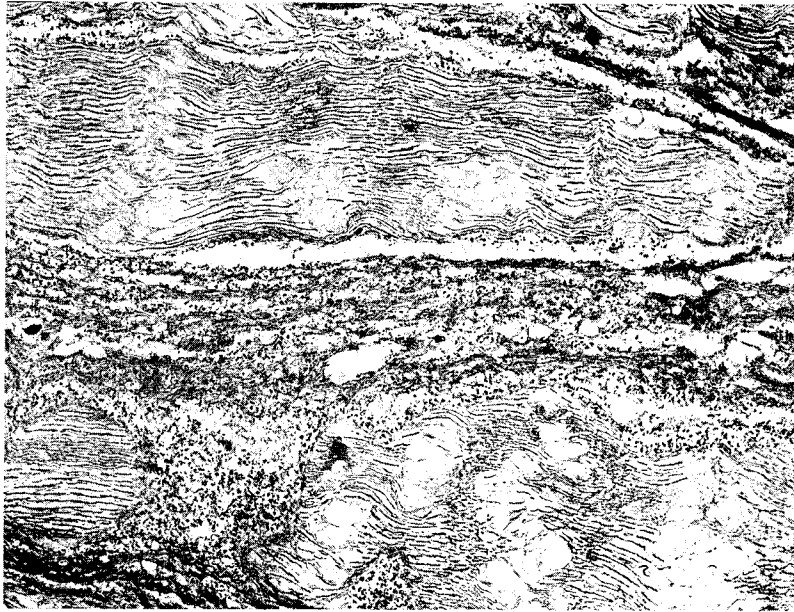

FIGURE 230.—Successful use of frozen dried homograft by tantalum sleeve technique in injury of median nerve at wrist. Necrosis is occurring nearer the center of the graft in the perineurium, while the fibers of the graft themselves remain largely intact and inert.

ably be attributed to technical considerations. On the contrary, they suggest an all-or-none acceptance of the graft by the host.

Exposure Technique

Because the technical measures of insulating the entire graft from the surrounding tissues was thought to play a possible role in the failure of frozen dried homogenous grafts, three grafts obtained from the sciatic nerve were subsequently placed without such insulation. The most favorable degree of neurotization occurred in case 2, the patient on whom the tantalum sleeve technique had originally been employed. When the original graft was removed as a failure, a fresh graft was placed, after the nerve ends had been freshened and the gap thus increased from 3.5 to 5.0 cm. The cavity left by removal of the tantalum sleeve included the nerve ends, and it was possible to suture it along its roof, so that nerve ends and graft filaments were held in good apposition.

This graft was left in situ for 11 months, chiefly because sensory recovery due to overlap and motor improvement by compensatory muscle functions were assumed to be evidence of returning median function. At the next (third) operation, the graft showed little change in the gross color to suggest vascularization, but both the graft and the distal nerve were sensitive

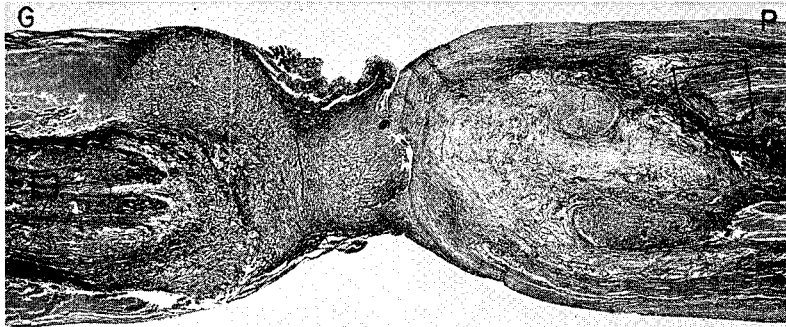

FIGURE 231.—Unsuccessful use of frozen dried homograft by tantalum sleeve technique in injury of ulnar nerve at wrist. Despite good attachment between nerve and graft, a solid cap of fibrous tissue divides the nerve from the graft. G, graft. P, proximal nerve end.

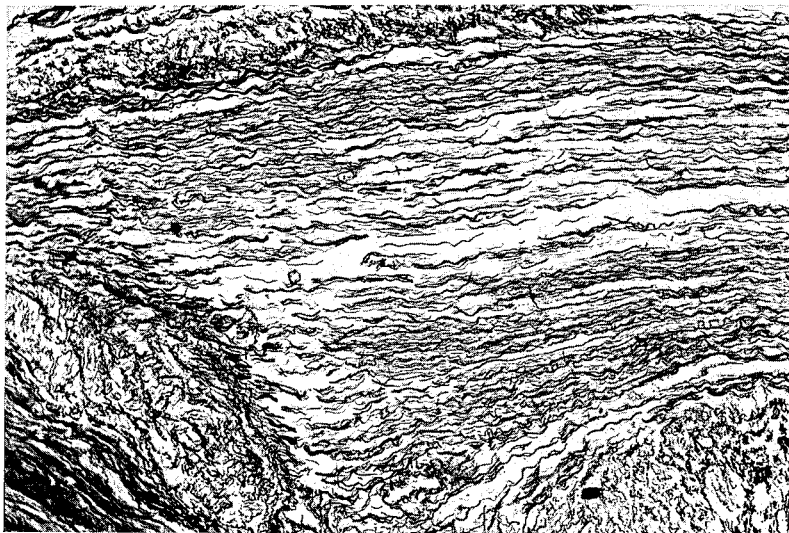

FIGURE 232.—Unsuccessful use of frozen dried homograft by tantalum sleeve technique in injury of ulnar nerve at wrist. Disorganization is present to a surprising degree, and nearly all the nerve fibers are amyelinic, although it would be reasonable to expect to find a nearly normal nerve in this area, which is well removed from the graft.

to electrical stimulation. In spite of this finding, the graft was removed because of the absence of motor response and the absence of, or reduction in, skin sensation when the distal nerve was blocked with procaine.

Histologic examination (figs. 234 and 235) showed that, after case 2 was operated on the second time, axons had penetrated through the proximal half of the graft in fair numbers until the area of marked fibrotic reaction was reached distally. In spite of this barrier, a few amyelinic nerve fibers were discernible beyond the graft in the distal nerve.

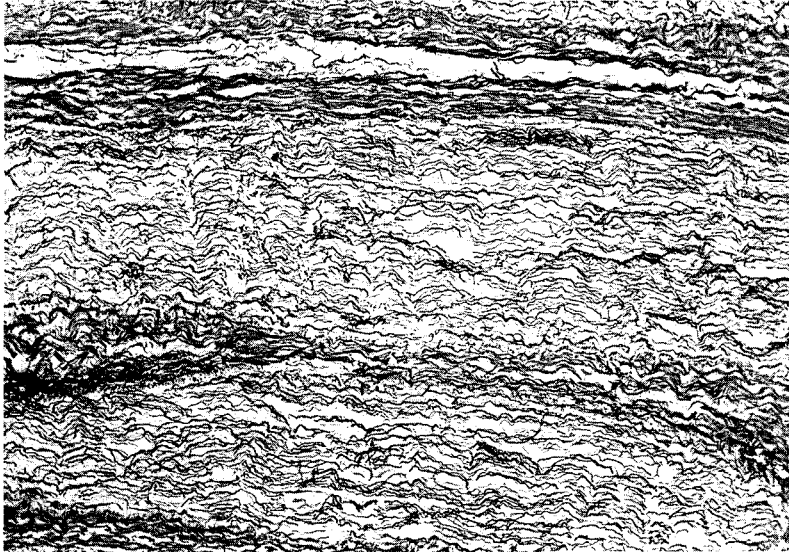

FIGURE 233.—Unsuccessful use of frozen dried homograft by tantalum sleeve technique in injury of ulnar nerve at wrist. Central portion of inert, intactly preserved graft. The appearance is more nearly that of normal nerve than the appearance of the section shown in figure 232.

In the other two grafts of this group, similar partial neurotization had occurred, but to a lesser degree.

Collagen Sleeve Technique

At this time, as already mentioned, it seemed that abandonment of insulation of the graft by the use of a tantalum sleeve had improved the situation by permitting vascularization of the grafts in all cases, with some minor degree of neurotization. It was also thought, however, that vascularization did not occur without a corresponding degree of fibrosis, which might seriously block the growth of nerve fibers.

As a compromise, therefore, a different type of insulation, with collagen sleeves, was instituted in four cases, with the hope that humoral exchange through these membranes, in the absence of fibroblastic ingrowth, might have a favorable influence. These four grafts, however, fared no better than the grafts originally encased in tantalum sleeves, whether judgment was by clinical standards or on the basis of the histologic appearance when the grafts were removed 5 to 9 months after they had been placed.

Prepared Bed Technique

In addition to the four grafts already described which were placed in a cavity preformed by the use of a tantalum sleeve which was discarded at the time of grafting, four other grafts were managed by the same technique



FIGURE 234.—Unsuccessful use of frozen dried homograft by exposure technique, after removal of tantalum sleeve (figs. 227, 228, 229, and 230). There is good ingrowth of axons toward the left, to the point of neuromatous formation, with slight continuity into the distal end. N, graft. D, distal nerve end. P, proximal nerve end.

except that the material consisted, instead of sciatic fascicles, of many filaments of cauda equina motor roots laid side by side.

Three of these grafts were entirely unsuccessful. The fourth (case 14) showed more neurotization than any of the other grafts removed as failures.

In this case, the defect in the median nerve, after resection of damaged nerve ends, was 5 cm. The frozen dried homograft was placed 6 months after injury and was reexplored 8 months later in its location just proximal to the wrist. Grossly, its appearance throughout was pink, and its caliber was uniform except for a reduction at the distal junction with the nerve. Both the graft and the distal nerve were sensitive to electrical stimulation, and there was a barely visible contraction in the opponens pollicis. These findings were considered inadequate evidence for regeneration 8 months after grafting, and the graft was therefore removed and primary suture accomplished. Although the histologic picture (case 14) (figs. 236 and 237) showed the persistence of many nerve bundles which had not been organized and there was considerable neuromatous disorganization and fibrosis, amyelinic regenerating fibers could be traced throughout the length of the graft and were discernible in a photomicrograph of the distal nerve end.

Results of Autogenous Nerve Grafts

For purposes of comparison, another illustration is included in this chapter, a cross section of the distal end of an autogenous (ulnar) nerve graft used to bridge a 9.8 cm. defect between the proximal end of the median nerve and a digital nerve to the index finger (fig. 238). The injury was caused by a shell fragment, which avulsed most of the soft tissues of the hand. The section shown, at the distal suture line, was removed 6 months after operation, when the graft was found to be sensitive and the distal nerve was inert to stimulation; a fresh suture was done at this point. The rich degree of neurotization observed in this autograft is in striking contrast to the findings in the homografts removed in this series.

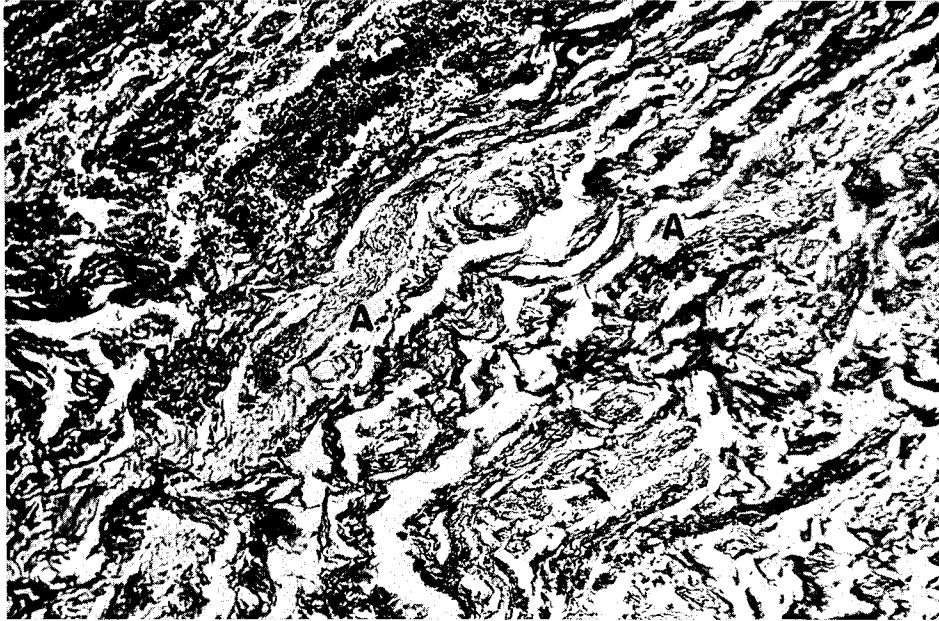

FIGURE 235.—Unsuccessful use of frozen dried homograft by exposure technique, after removal of tantalum sleeve (figs. 227, 228, 229, and 230). In this section from the distal end of the graft, some neurotization by regenerating amyelinic fibers is seen to the right of the areas marked A.

SUMMARY AND CONCLUSIONS

Definite success was achieved in only 2 of 26 frozen dried homografts used to bridge defects in major peripheral nerves at the neurosurgical center at Cushing General Hospital in 1944-45. Different techniques were used in each of the successful cases. The single successful graft to a large mixed nerve occurred through a short (3-cm.) defect. In general, insulation of any greater length of nerve by a foreign body appeared to doom the procedure to failure because the center of the insulated bridge apparently remained inert and seemed actually to repel any attempt at axonal invasion, even when the invasion had got off to a fair start in the proximal segment of the graft.

In two instances, exposure of the graft to surrounding tissues permitted some neurotization, which was, however, inadequate to extend throughout the length of the graft. The impression was received that neurotization was interfered with by the fibrotic reaction that occurred in the exposed graft. While this reaction did not interfere with the functional success of a facial nerve graft, in this case, the situation was far more favorable because of the use of fine filaments and the unusual regenerative capacities of this pure motor nerve.

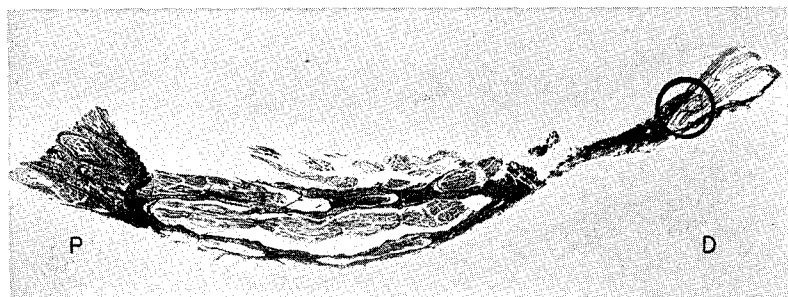

FIGURE 236.—Unsuccessful use of frozen dried homograft by collagen sleeve technique. The proximal end of the nerve is well attached to the graft in minimal continuity with the distal end. Much of the graft has not undergone organization, although some neurotization has occurred throughout. P, proximal end. D, distal end.

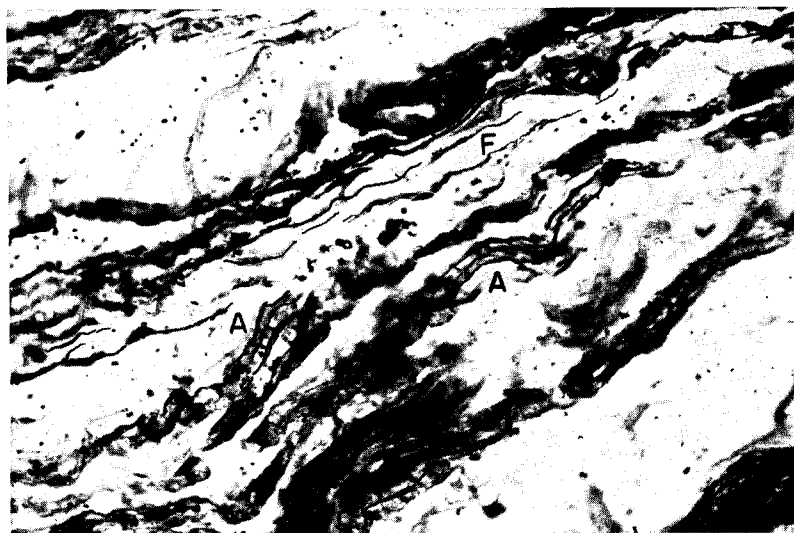

FIGURE 237.—Unsuccessful use of frozen dried homograft by collagen sleeve technique. Inert fibers of the graft as seen at the junction of the graft with the distal nerve (A), while regenerating fibers are seen in another area (F).

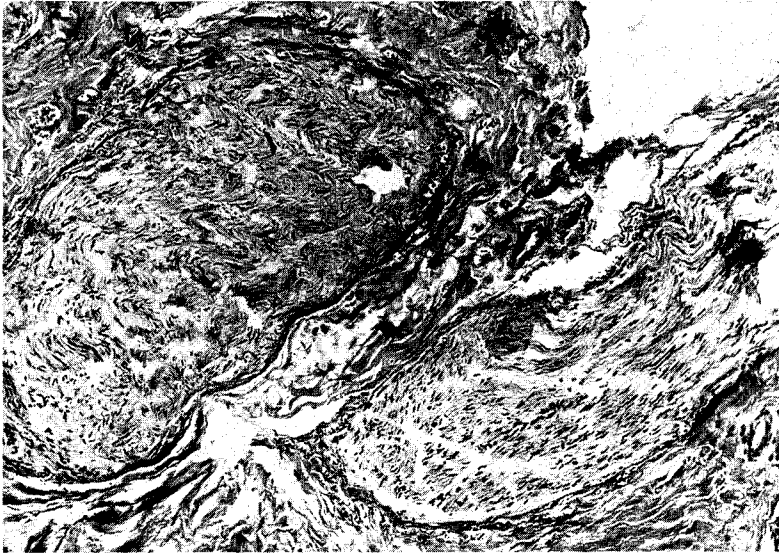

FIGURE 238.—Successful autogenous (ulnar) nerve graft used to bridge 9.8 cm. defect between proximal end of median nerve and digital nerve to index finger. Cross section of distal 1 mm. of this graft. Note the high degree of neurotization by amyelinic fibers.

In the five instances in which homografts were inlaid into partial defects involving from a third to two-thirds of the cross section of the nerve, it seemed possible, and usually seemed probable, that the observed recovery occurred through the intact portion of the nerve. In two cases (cases 19 and 20), recovery was better than might have been expected since half of the nerve was missing. In two cases (cases 18 and 19), the graft appeared to have some degree of function at reexploration. In a third case (case 17), the graft looked like a foreign body at the second operation, although circumstances for its vascularization and neurotization were highly favorable. It may be that only this last observation is of importance; it emphasizes the possibility of complete rejection of the graft by the injured nerve in situations in which grafting could most logically be expected to be successful.

CHAPTER XXI

Neuropathologic Changes in Battle-Incurred Injuries of Peripheral Nerves

William R. Lyons, Ph. D., M.D.

During the period between 19 February and 11 June 1945, inclusive, 105 external neurolyses and 228 neurorrhaphies (on 203 patients) were performed in the neurosurgical section, Halloran General Hospital, Staten Island, N.Y. The 228 specimens secured in the course of the nerve repair operations were studied jointly by the surgeons and the pathologist attached to the service. The collaborating neurosurgeons were Maj. John J. Lowrey, MC; Maj. Benjamin B. Whitcomb, MC; Capt. George T. R. Fahlund, MC; Capt. Wade C. Myers, MC; Capt. William T. Muse, MC; Capt. Stanley E. Potter, MC; and Capt. (later Maj.) Hugo V. Rizzoli, MC.

There were several reasons for making this study a cooperative endeavor between neuropathologist and neurosurgeons, as follows:

1. To study each nerve specimen with the aid of special stains, in order to accumulate information for use in the handling of future cases.
2. To determine the effect of the time element on the creation of adverse and irreversible changes in distal segments and on the degree of fibrosis in the nerve stumps in relation to the distance from the main point of injury.
3. To apply to each case the information gained previously in other cases with the aid of the microscope and correlated with the appearance of the lesion at surgery. Thus, it was not enough to ascertain that a good fascicular pattern was exposed on each stump by fresh sections. Careful scrutiny with the aid of a binocular loupe supplemented by discriminating palpation of each nerve was necessary to detect any suggestion of fibrosis due to stretch ischemia or time lapse.
4. To insure the direct collection of an adequate number of nerve ends representative of the tissue finally coapted, so that, at a future date, a correlation might be struck between the quality of the cross sections and the degree of functional restoration.

MATERIALS AND METHODS

All 228 specimens were received directly by the pathologist from the surgeon immediately after excision. After 24 hours' fixation in 10 percent formalin, buffered with magnesium carbonate, the specimens were cut into

transverse and longitudinal sections and embedded in paraffin. They were then cut at 8-10 micra, were impregnated by means of the Bodian Protargol method, and were counterstained with a phosphomolybdic acid-aniline blue mixture.

Of the 228 specimens, 152 were secured from the upper extremity and 76 from the lower extremity. In the upper extremity, 12 were secured from the brachial plexus, 1 from the suprascapular nerve, 1 from the axillary nerve, 4 from the musculocutaneous nerve, 35 from the median nerve, 54 from the ulnar nerve, 39 from the radial nerve, and 6 from the cutaneous nerve of the forearm. In the lower extremity, 25 were secured from the sciatic nerve, 1 from the femoral, 22 from the posterior tibial, 26 from the common peroneal, and 2 from the sural nerve.

The number of specimens from the upper extremity was almost double the number from the lower, and specimens from the ulnar nerve were in excess of all others. Essentially the same distribution was noted in a series of 163 consecutive neurorrhaphies at Walter Reed General Hospital, Washington, D.C., over an 8-month period just before this study was undertaken.

The specimens fell into two main groups, as follows: (1) Lesions in continuity and (2) lesions with complete severance. These specimens were further categorized as follows:

Specimens:	<i>Number</i>
Completely severed nerve stumps	54
Severed nerve stumps in fibrous continuity	13
Partial neuromas in continuity	20
Complete neuromas in continuity	83
Nerve segment eroded by aneurysm	1
Sites of—	
definitive neurorrhaphy	18
temporary neurorrhaphy	30
disrupted sutures	6
bulb sutures	3
Total	228

Because of their special interest, a fresh whole nerve homograft, a frozen dried homograft, a fresh cable autograft, and a nerve showing fresh fibrosis are included in the discussion, but, because they were collected after the other specimens had been analyzed statistically, they are not included in the analysis.

TIME LAPSE

The following tabulation shows the distribution of the cases in this series in relation to timelag between wounding and suture in 203 peripheral nerve injuries:

Timelag, in months:	Cases (number)
0-1	1
1-2	7
2-3	33
3-4	49
4-5	40
5-6	25
6-7	16
7-8	8
8-9	6
9-10	5
10-11	6
11-12	3
12-13	4
Total	203

It is probably true that the majority of the 203 patients were operated on as early as possible, but it is also true that the surgeons concerned would rather have performed the operation before, instead of after, the third month, as was necessary in 80 percent of the cases.

COMPLETELY SEVERED NERVE STUMPS

Study of the completely divided nerves by means of routine application of the Protargol technique of impregnation provided an abundance of information on all stages of wallerian degeneration as well as on the degenerative and regenerative phases in the proximal stump. The whole series was sufficiently large and diversified to permit one to identify in the human all of the main findings reported by Ramón y Cajal¹ in his classical work on nerve degeneration and regeneration in experimental animals. Efforts were directed toward evaluating and understanding each specimen on the basis of (1) the nature of the traumatizing agent, (2) the observed trauma, and (3) time relations.

Photographs were taken of the cross sections representing mirror images of the nerve ends finally sutured and of longitudinal sections of all nerves made after fixation. Figure 239A shows the typically enlarged and neuro-matous proximal stump, surrounded by epineurial adhesions of fat, muscle, and scar tissue, and the slightly shrunken distal stump, largely fibrotic and also covered by adhesions. Even after resection of about 6 cm. of nerve, the surgeon was still faced with considerable disparity in the cross sectional area of the two ends. The topographic histology of these ends is shown in figure 239B and C. It should be noted that, while they represent a fair average of all ends coapted in this series, they are, nevertheless, fibrotic between and around the fascicles and show considerable edema within the proximal fasci-

¹ Ramón y Cajal, Santiago: Degeneration and Regeneration of the Nervous System. Translated and edited by Raoul M. May. New York: Oxford University Press, 1928.

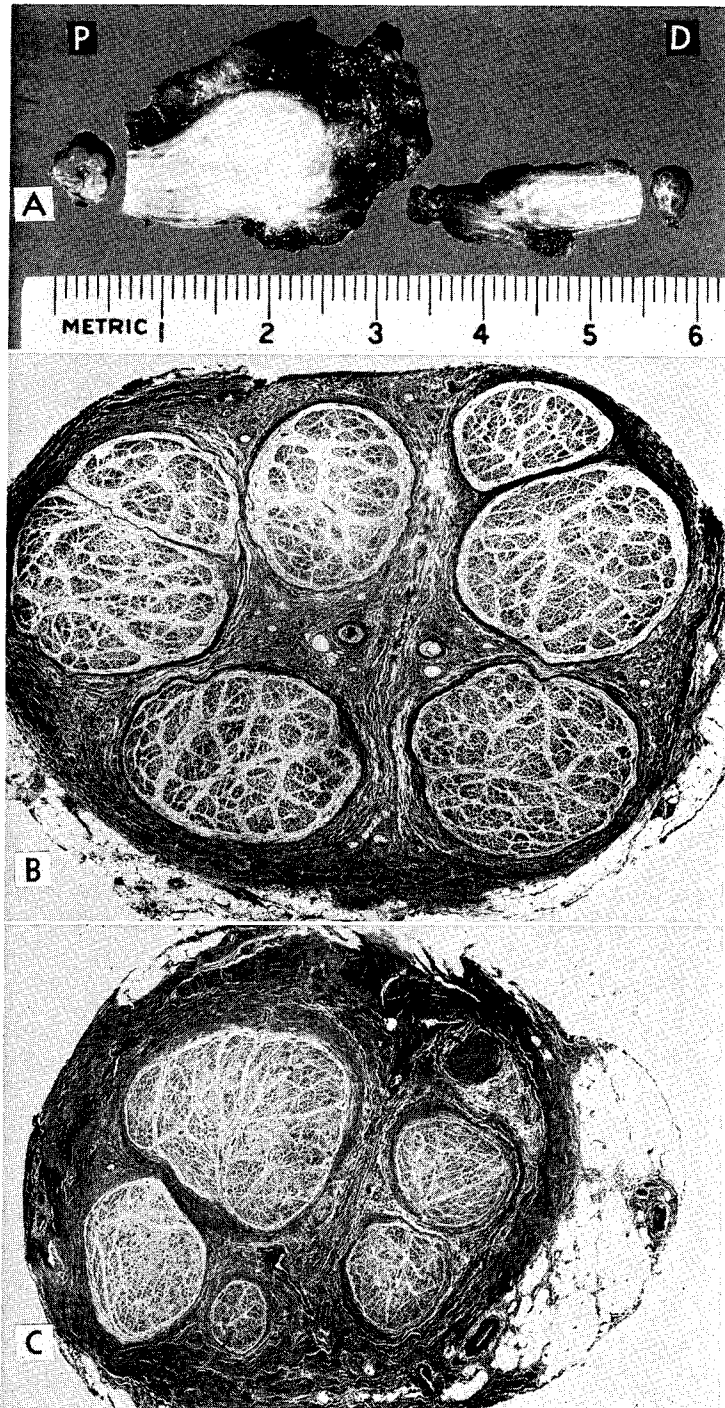

FIGURE 239. (See opposite page for legends.)

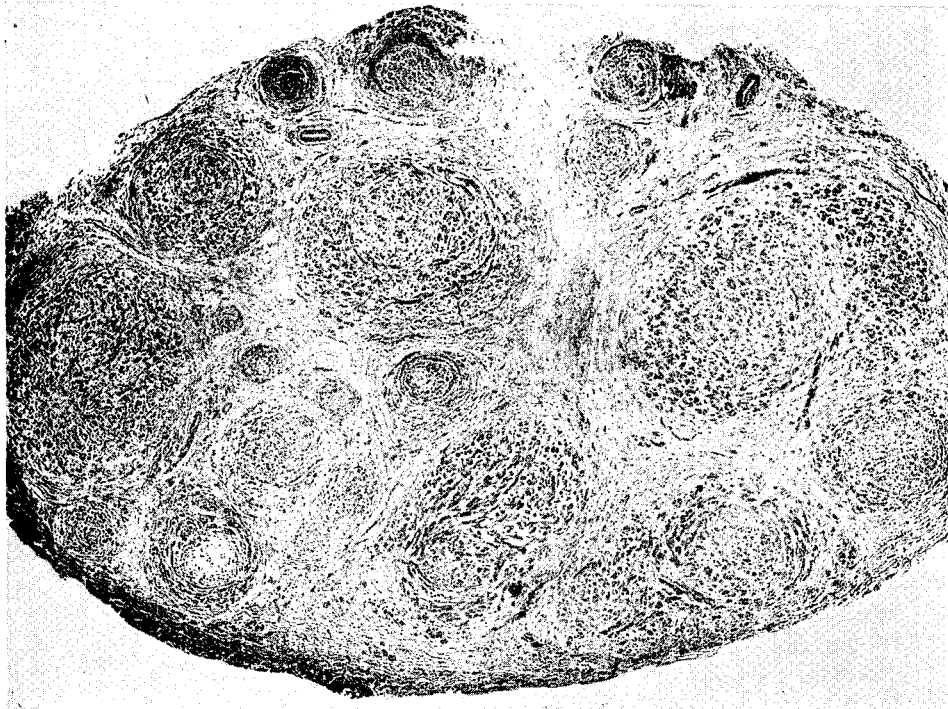

FIGURE 240.—Cross section of proximal stump of severed musculocutaneous nerve illustrating diffuse neuromatous proliferation involving the entire section and obliterating most fascicular outlines. Great numbers of small neuromatous bundles have grown out of the fascicles into the regions between the fascicles and beneath the epineurium. ($\times 15$)

cles. The pathologist learned to overlook such thickening of epineurium as is seen here because it was highly respected and valued by the surgeon, not only for better guidance of his needle, but also for more efficient maintenance of his sutures.

Figures 240 and 241 are representative of cross sectional areas of proximal and distal nerve stumps taken from regions nearer the point of severance. They illustrate the types of reaction that the surgeon attempted to avoid by cutting back the ends. The proximal section (fig. 240) consists of large numbers of small regenerating nerve bundles growing in disarray amid

FIGURE 239.—Complete severance of ulnar nerve. A. Ulnar nerve completely severed by mortar shell fragment 8 $\frac{1}{4}$ months previously. (Soldier was prisoner of war in Germany for 7 months.) Note the enlarged and neuromatous proximal stump surrounded by fat, muscle, and scar tissue, and the slightly shrunken distal stump (D). The fascicles shown in the proximal cross section are extremely edematous. ($\times 1.5$) B. Proximal cross section of nerve shown in A. Note intrafascicular edema and moderate interfascicular and epineurial fibrosis. ($\times 20$) C. Distal cross section of specimen shown in A. Note epineurial, perineurial, and interfascicular fibrosis. The small fascicle at the upper left has become almost obliterated. ($\times 20$)

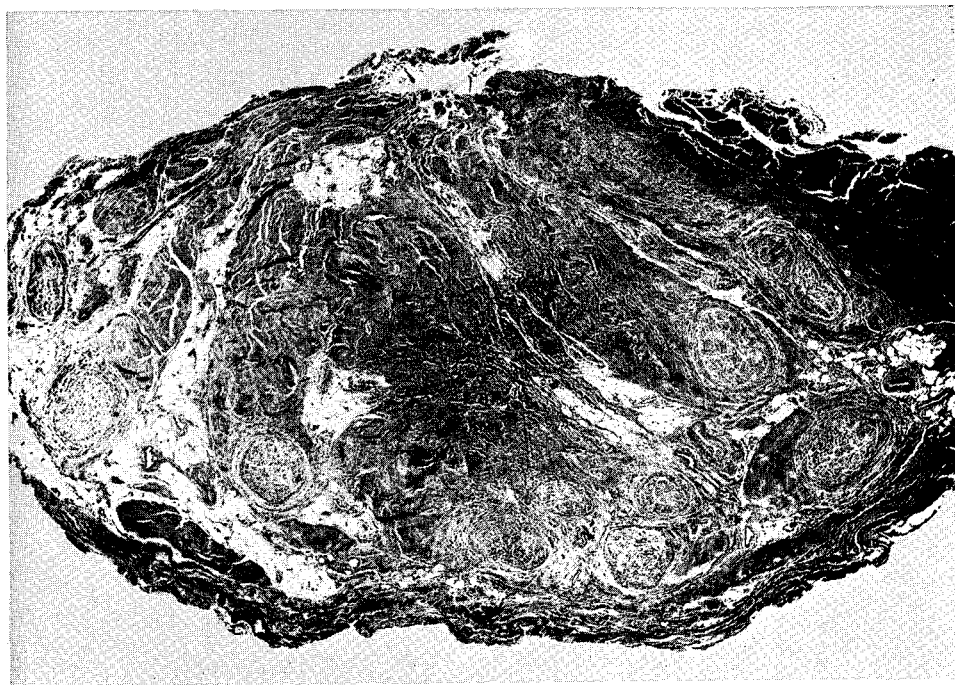

FIGURE 241.—Cross section of distal stump of severed branch of femoral nerve showing marked generalized fibrosis around and between the shrunken, degenerated fascicles. Note also fat and dense epineurial scar tissue. ($\times 22.5$)

granulation tissue. These bundles illustrate the tremendous force delivered by the nerve cell body to the peripherally damaged fibers, which may send out as many as 40 fine fibrils from a single axis cylinder. The fascicular sheaths are found obliterated for a distance of 1 centimeter or more proximal to the point of severance, with neuromatous fibers escaping in all directions, and usually through the epineurium into the surrounding tissue. The distal section (fig. 241) shows atrophic nerve fascicles buried in dense scar tissue and fat.

Figure 242 shows in longitudinal sections the improvement attained by resecting the proximal and distal stumps as far back as seemed safe, with due regard to subsequent tension. Figure 243 and color plates 1 through 7 are examples of the studies routinely made at higher magnifications of the proximal and distal sections cut in the longitudinal and transverse planes. The use of a Protargol and aniline blue combination permitted a study of the degenerative and regenerative changes in axis cylinders on the one hand and the degree of fibrosis on the other. It was possible to accumulate facts on retrograde degeneration in the proximal stump nerve fibers, as well as to witness the amount and nature of the regrowth of such fibers. The study of intrafascicular fibrosis and tubular shrinkage in the distal stumps was deemed of even greater practical importance than the study of regeneration, not only



PLATE 1.—Cross section through proximal fascicle of ulnar nerve severed by mortar shell fragment $5\frac{1}{2}$ months earlier. Resection of this stump was made approximately 20 mm. central to the severance point, and the histologic pattern shown here is essentially that of a normal nerve. There is some edema, but very little intrafascicular fibrosis and no perineurial thickening. Some of the tubules have remained degenerated and appear empty; others show regrowth of one or more nerve fibers. Most of the fibers appear normal, with thick axons and wheelspoke neurokeratin patterns in their myelin sheaths. ($\times 600$)

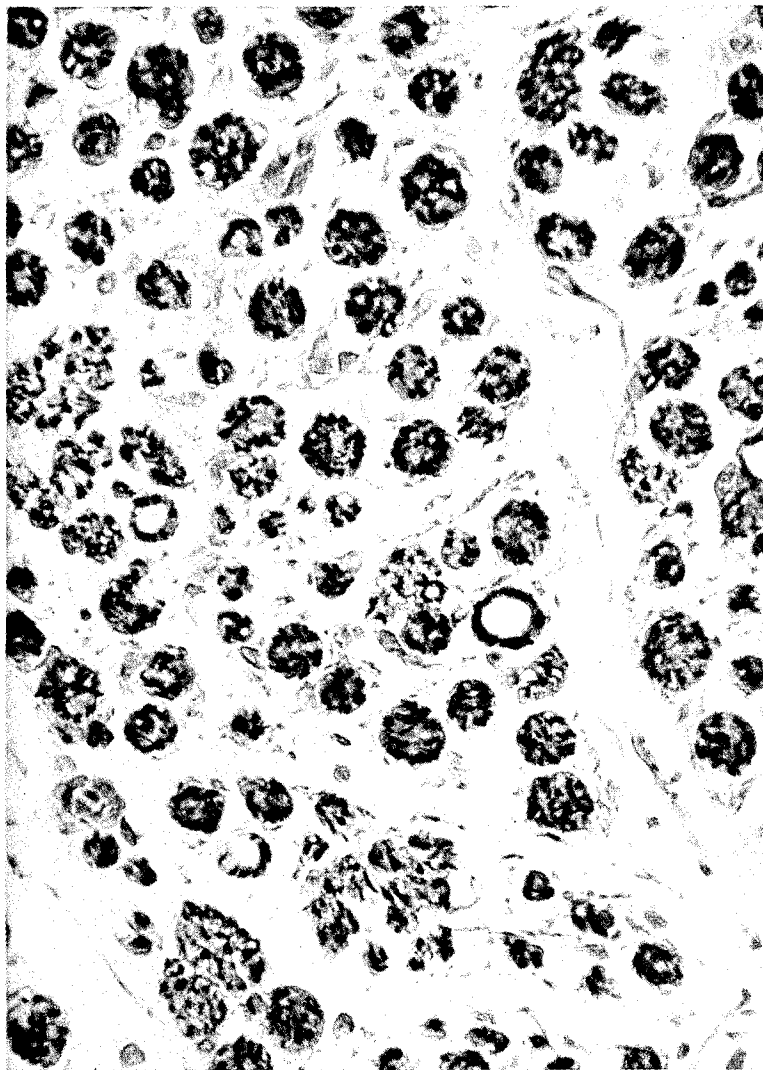

PLATE 2.—Cross section through proximal fascicle of median nerve severed by bullet 2½ months earlier. Resection of the stump was made approximately 15 mm. central to the severance point. The picture shown here is one of profuse regeneration of amyelinated and lightly myelinated fibers along and within the swollen, degenerated tubules. Only a few of the tubules have remained empty, and even these show small fibers regenerating along their outer sheath surfaces. Some fibers appear to have taken isolated pathways in the edematous endoneurium between the old tubules. Some of these, as well as fibers within the tubules, show a narrow, clear area between the axon and neurilemma, indicative of new myelination. (× 600)

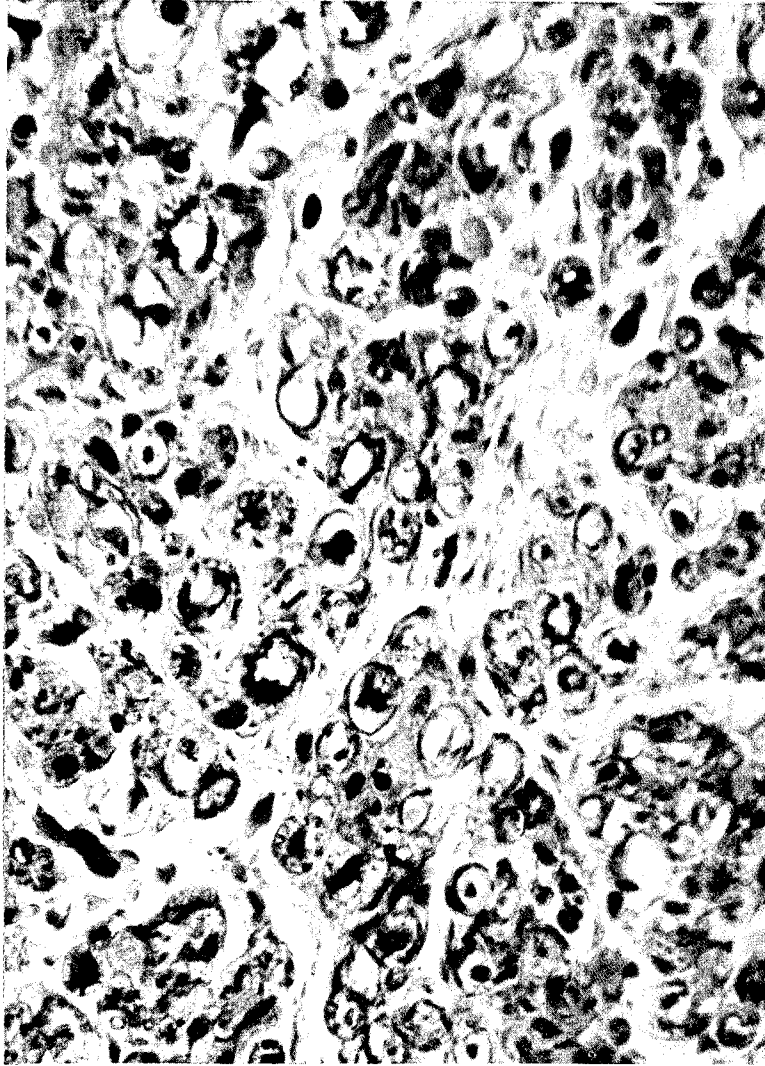

PLATE 3.—Cross section through proximal fascicle of median nerve severed by glass 1 week earlier. Resection of this stump was made approximately 10 mm. central to the severance point. Here may be seen the various phases of myelin sheath and axonal disintegration. In a few of the degenerating fibers, remnants of the neurokeratin network are still present. The axonal fragments have assumed bizarre shapes within the distended neurilemmal sheaths. Some of the nuclei especially adjacent to the old sheaths belong to the Schwann cells, while others, between the tubules, are fibroblastic. Macrophages with spheroidal nuclei have migrated into some of the tubules. Some of the fine black dots in different regions of the section represent what was judged to be the early phase of filamentous regeneration of a few of the least-injured axons (seen better in long sections). ($\times 600$)

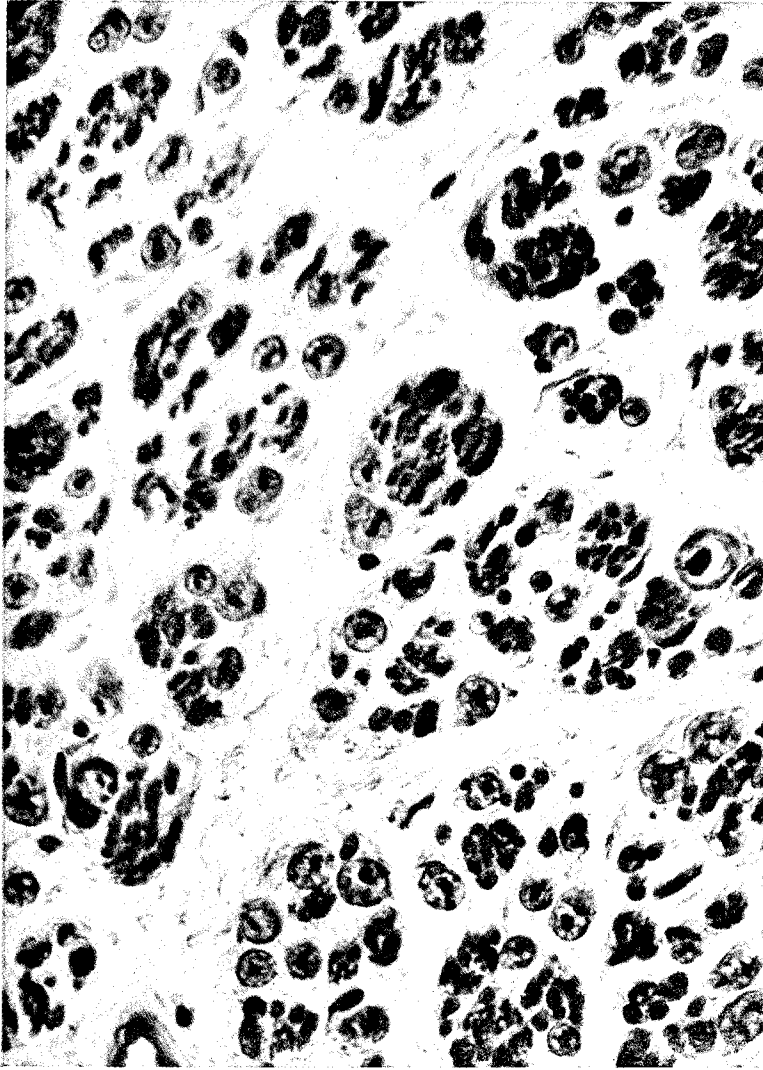

PLATE 4.—Cross section through proximal fascicle of ulnar nerve severed 3 months earlier by bullet. This stump was resected at a point approximately 20 mm. central to the severance point. The section was made through a region in which most of the nerve fibers had undergone retrograde degeneration. Although a fair number of normal appearing, well-myelinated fibers are seen, the majority of the fibers represent regenerating and thickening axons in clusters or isolated. Some of these show evidence of new myelination. ($\times 600$)



PLATE 5.—Longitudinal section through proximal fascicle of sciatic nerve severed by shell fragment 4 months earlier. In this region, the injured myelinated fibers had given off many fine and ravelled filaments that had progressed distally for approximately 20 mm. to form a large neuromatous bulb. ($\times 600$)

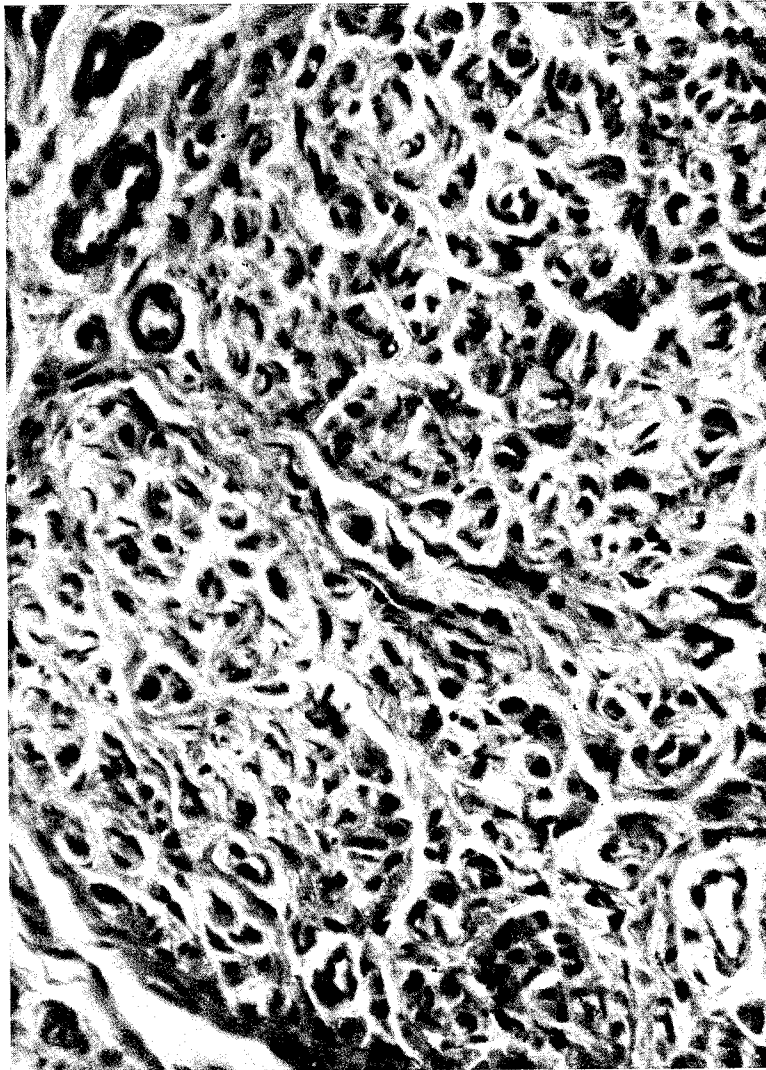

PLATE 6.—Cross section through distal fascicle of median nerve severed by shell fragment 7 months earlier. Although many small collateral vessels had developed since injury, this segment of nerve had remained relatively ischemic and presented a histological picture of marked endoneurial fibrous overgrowth with almost complete destruction of the usual tubular pattern. ($\times 600$)

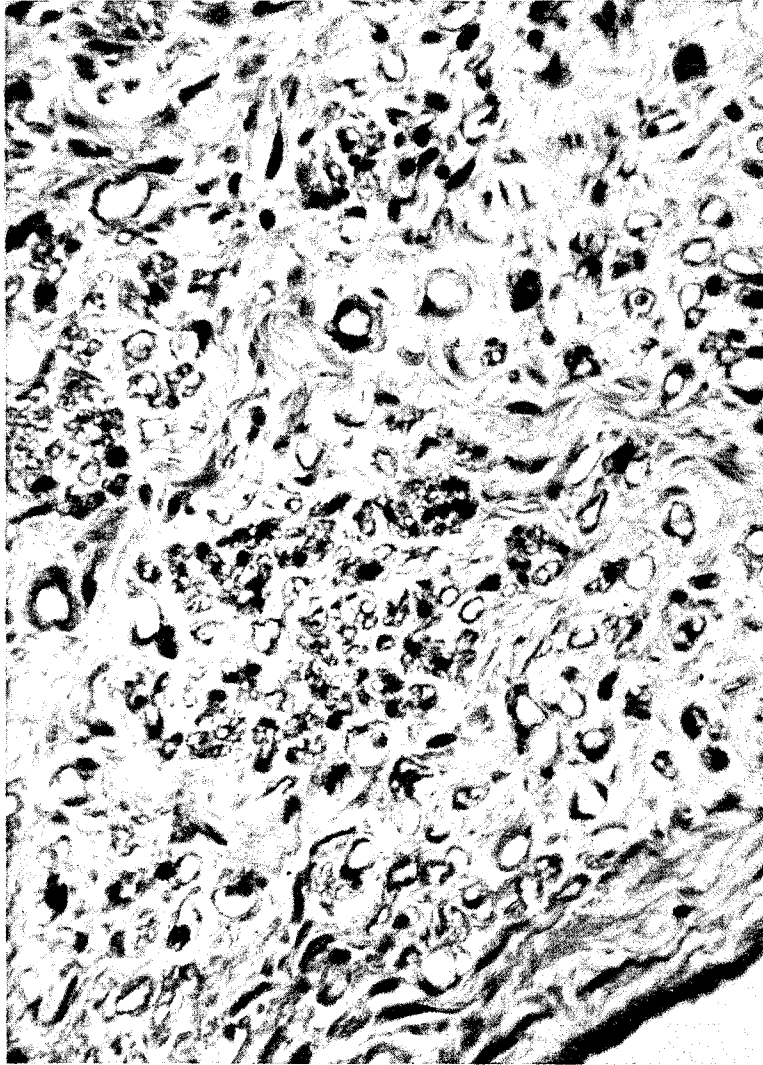

PLATE 7.—Cross section through distal fascicle of sciatic nerve severed by steel fragment 2 $\frac{2}{3}$ months previously. The marked endoneurial fibrosis shown here was not seen in all fascicles at this level (approximately 15 mm. distal to the severance point). Medial parts of this outer fascicle showed large tubules with minimal fibrosis. The variation in tubular shrinkage shown here indicates that the proximity to the point of injury is just as important a factor as the time interval in determining the degree of endoneurial fibrosis. (\times 600)



PLATE 8.—Longitudinal section through fascicle of proximal segment of neuroma in continuity in posterior cord of brachial plexus severed by shell fragment 5½ months earlier. Considerable fibrous replacement had taken place in this fascicle, and, within this fibrous tissue, a well-thickened regenerated axon had formed two bulbs simulating compound sensory corpuscles. In the distal bulb, the axon ends in a skeinlike growth, within which Schwann cells may be seen. Below are seen clusters of regenerating amyelinated fibers accompanied by Schwann cells. ($\times 600$)



PLATE 9.—Longitudinal section through proximal end of 70-mm. long neuroma in continuity in common peroneal nerve injured by mortar shell fragment 2½ months earlier. A few degenerated tubules containing axonal debris, fat, and proliferating Schwann cells are present; otherwise, this field, which is typical of the rest of the fascicle, is entirely occupied by innumerable axonal sprouts attended by Schwann cells, growing in parallel lines within, or sometimes on, the outer surface of the old tubules. (× 600)

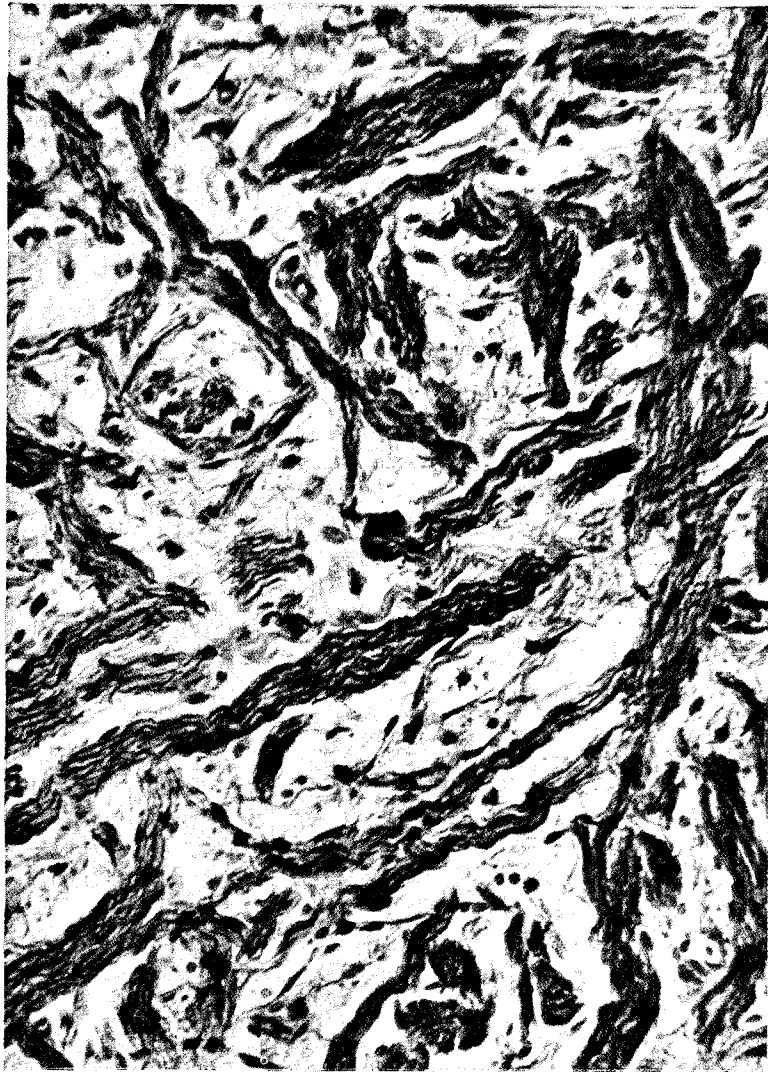

PLATE 10.—Longitudinal section through neuroma in common peroneal nerve severed by machinegun bullet 4½ months earlier. The nerve ends separated, and a narrow fibrous and neuromatous isthmus formed between them, made up of the types of tissue shown here. Without the guiding aid of neurilemmal tubules, the regenerating axons grew in all directions and formed intricate networks comparable to the diffuse nets that some nerves form in the skin areas. Schwann cells can be seen closely applied to the branching axonal filaments. Macrophages filled with globules and fibroblasts are present in the intervening fibrous tissue. (× 600)

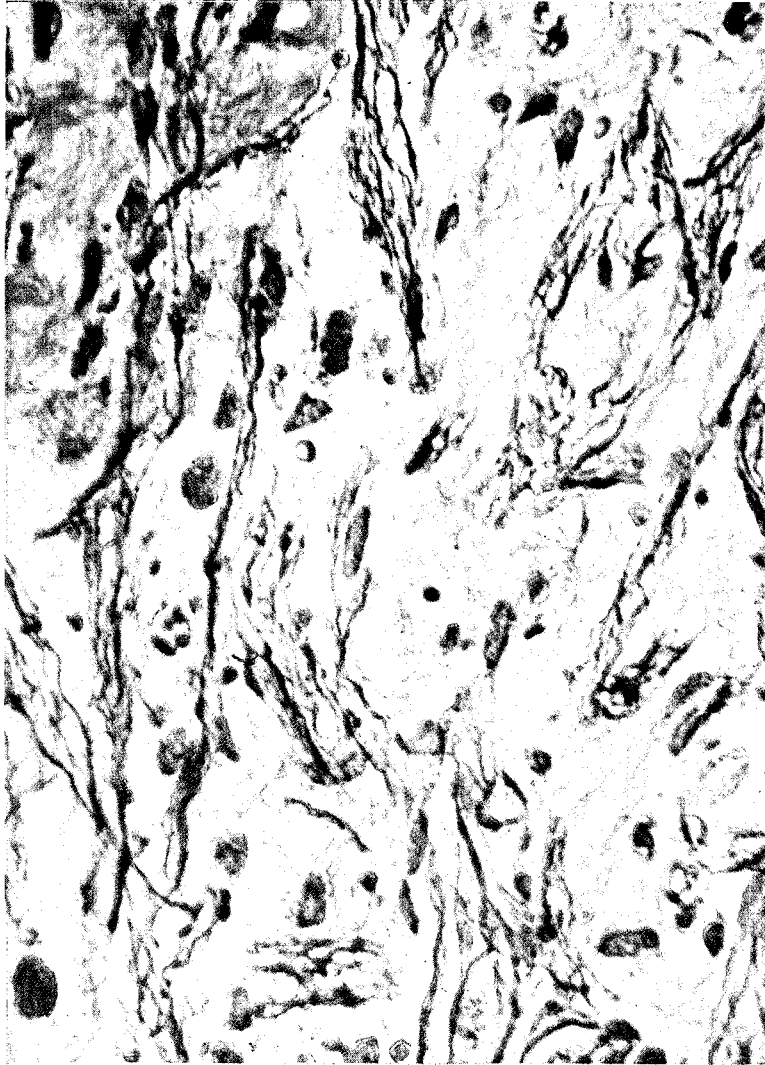

PLATE 11.—Longitudinal section through midsegment of neuroma in continuity in median nerve injured by bullet 3½ months earlier. This section represents a later phase of the same crisscross pattern of nerve fiber growth seen in plate 10. The small nerve bundles have become more dense, due in part to a thickening of the individual filaments. Communications could be traced between different nerve bundles, and the arrangement shows some similarity to that of an autonomic nerve plexus. (× 600)



PLATE 12.—Longitudinal section through proximal segment of frozen dried nerve homograft placed in defect of posterior tibial nerve severed 29 months earlier and grafted 1 year earlier. Small bundles of amyelinated nerve fibers (black) had penetrated the graft for a distance of 15 mm. An ovoid structure simulating a compound end organ is seen in the upper part of the field. Most of the graft has been replaced by dense collagenous tissue (blue). ($\times 600$)

in regard to followup studies but in guiding and reemphasizing the policy of early suturing of nerves.

Figures 243D, 244, and color plates 6 and 7 show representative cross sections taken from a large series of distal stumps resected from 7 days to 7 years after nerve severance. It was learned from this study that the neurilemmal tubules usually remained unshrunk for a month or two after nerve transection, with a gradual shrinkage accompanied by endoneurial fibrosis during the following months. The extremely dense collagenization seen in 1 case (fig. 244D) after 25 months was sometimes seen as early as the sixth month. The maintenance of patent though shrunken tubules, even after 2 years, provides partial evidence to explain the regeneration seen in the distal parts of nerves sutured after long intervals of time, or in nerves sutured at long distances from their terminations. Further studies will be required to determine how well nerve fibers gaining access to the attenuated tubules or the fibrotic intertubular regions are able to thicken and myelinate.

SEVERED NERVE STUMPS IN FIBROUS CONTINUITY

The 13 specimens in this group differed from those secured from completely severed nerves in that narrow strands of what appeared to be largely fibrous tissue connected the severed stumps (fig. 245). Histologically, this tissue was found to be the reinforced residue of a few shreds of nerve substance not cut through by the injurious agent. This type of specimen was often found in conjunction with bone fractures, the association suggesting that the jagged bone edges rather than the missile had been responsible for the trauma. Although the isthmus was almost completely fibrotic (fig. 245C), it was usually possible to find microscopic evidence of fine nerve filaments regenerating through it to the distal segment.

It must be borne in mind that sparse regeneration of nerve fibers through such attenuated connections—and indeed through the scarred bed of completely separated stumps—into the distal segment may be responsible for the diagnosis of an advancing Tinel sign. This error leads to the conclusion that a positive Tinel sign progressing distalward is not a valid reason, in the absence of other favorable signs, such as resumption of function in muscle, for postponing surgical exploration and neurorrhaphy. The possibility of an advancing Tinel sign is no guarantee that sutured stumps have remained in adequate continuity. This is why it was considered an advantage to use tantalum sutures and markers, which can be readily seen in X-ray films, to be certain that sutured stumps had not become disrupted.

NEUROMAS IN CONTINUITY

The problem of deciding whether to resect or leave nerve lesions in continuity (fig. 246) was often very difficult. During the period of this survey,

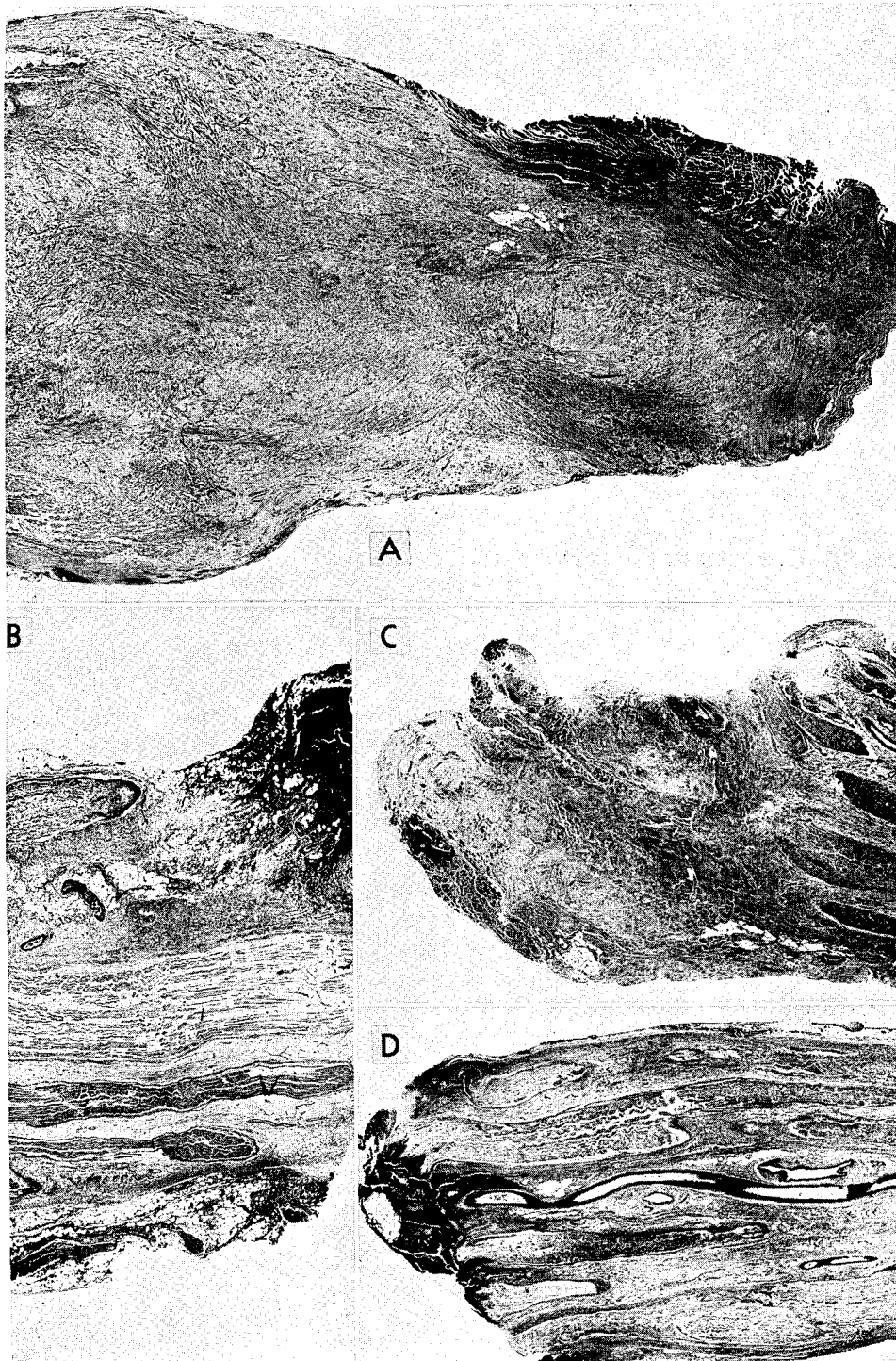

FIGURE 242. (See opposite page for legends.)

as already mentioned, 105 lesions in continuity were explored and not resected. Their appearance and their response to electrical stimulus suggested that they required little more than a lysis from scar tissue and sometimes the placement of a tempered tantalum sleeve. During this same period, 103 lesions in neuromatous continuity were removed and studied as specimens. This figure indicates not only that the neurosurgeons were cognizant of the formidable barriers to good nerve regeneration present in such lesions but also that they had confidence in their ability to overcome these barriers by neurorrhaphy. That they were amply justified has already been shown by a microscopic study of the parts resected and by the rapid functional return in the great majority of the sutured nerves.

Although the causes for the formation of neuromas in continuity are many and varied, most of the lesions in this series appear to have been caused by partial severance or severe contusion by missile fragments or by fractured bones. Two-thirds were caused by artillery shell fragments and about one-third by small weapon missiles; only three were due to landmines and only two to aerial bombs. In a third of the cases, fracture of a neighboring bone accompanied the nerve injury, and the presence of bone fragments within some of the neuromas in continuity (fig. 247) seemed an adequate explanation for their formation. In other instances, a single small fragment of steel, lead, or brass (fig. 248) would be found embedded in the nerve, and, because it was often at some distance from the main wound, it was assumed to be the sole contributing factor.

Depending upon the nature of the inflicting force, the lesions varied from a small epineurial scar or wartlike excrescence to a large fusiform swelling twice the normal diameter of the nerve (fig. 249). When it was possible for the surgeon to separate whole and healthy fascicles from the neuromatous part of the nerve, only the latter was resected (fig. 250) and a partial or knuckle suture was performed. In some neuromas in continuity, only one or two fascicles had remained intact (fig. 251), and these were often enclosed in such dense scar tissue that the entire lesion had to be resected. In most cases, however, all of the fascicles appeared to have been disrupted, and their sheaths were so damaged and torn as to preclude the proper alinement of the regenerating nerve fibers (figs. 252 and 253).

FIGURE 242.—Complete severance of posterior tibial nerve. A. Median longitudinal section through neuromatous proximal stump of severed posterior tibial nerve. Fascicular pattern is completely lacking. ($\times 9$) B. Section just proximal to neuromatous bulb shown in A. Regularly arranged fascicles are present, although there is still some interfascicular fibrosis, and the central fascicle is very edematous. ($\times 9$) C. Median longitudinal section through distal stump of nerve shown in A, with point of severance (at left) showing complete fibrosis. ($\times 9$) D. Section just distal to fibrotic stump shown in C. This section demonstrated the improvement attained by resecting approximately 1 cm. beyond the zone of contusion. Areas of fibrosis are interspersed between regular fascicles and longitudinally directed blood vessels. Note clot at left formed at end of artery following first transection. ($\times 9$)

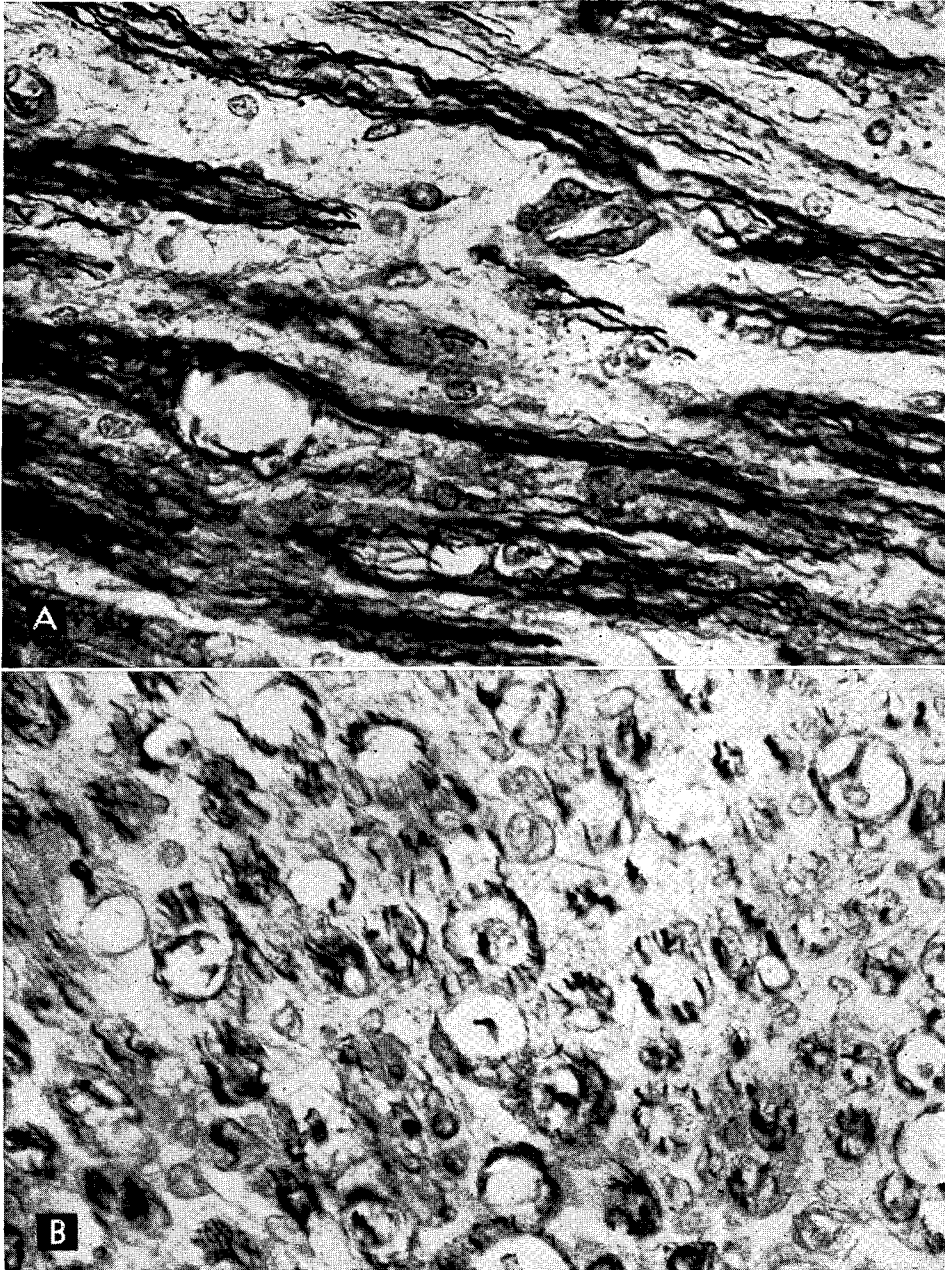
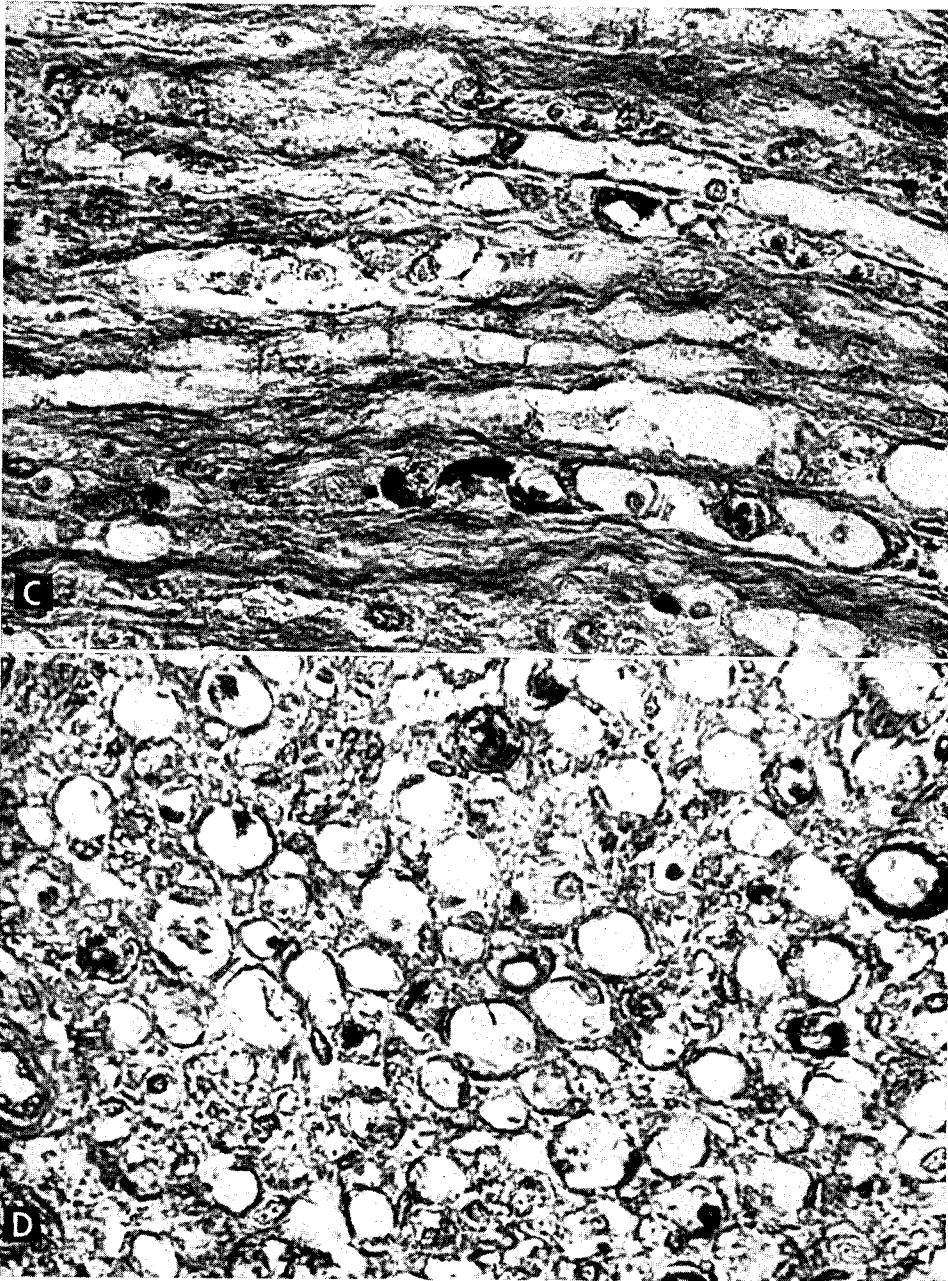

FIGURE 243.—Complete severance of radial nerve. A. Longitudinal section through proximal stump of radial nerve severed 41 days previously by machinegun bullet. Regenerating, amyelinated nerve fibers have grown along degenerated tubules. Note regions of tubular distension. ($\times 600$) B. Proximal cross section of nerve shown in A. Note regenerating nerve fibers in walls and lumina of degenerated tubules and in zones of



intertubular fibrosis. ($\times 600$) C. Longitudinal section through distal stump of nerve shown in A. Note degenerated Schwann tubules containing debris and macrophages. Excessive collagenization is seen between tubules. ($\times 600$) D. Cross section through same distal stump shown in C. Note that 41 days after section the tubular detritus is still in process of being resorbed and that the tubules are slightly distended. ($\times 600$)

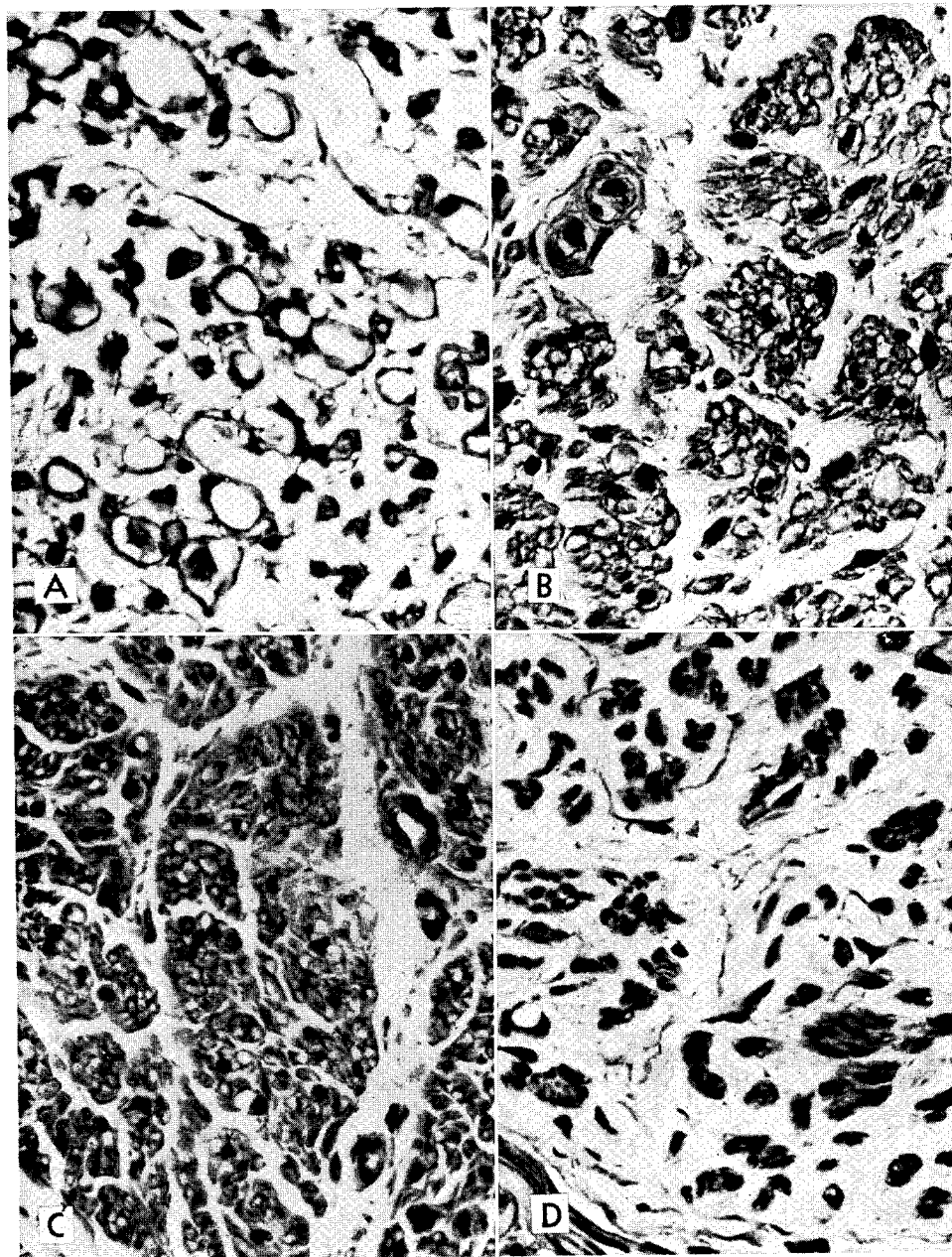

FIGURE 244.—Cross sections through fascicles of distal stumps showing changes in size of Schwann tubules and replacement fibrosis which may be considered typical of entire series of degenerated distal segments. A. Cross section resected from median nerve severed 2½ months earlier. B. Cross section from posterior tibial nerve severed 5 months earlier. C. Cross section from median nerve severed 14 months earlier. D. Cross section from posterior tibial nerve severed 25 months earlier. (All × 600)

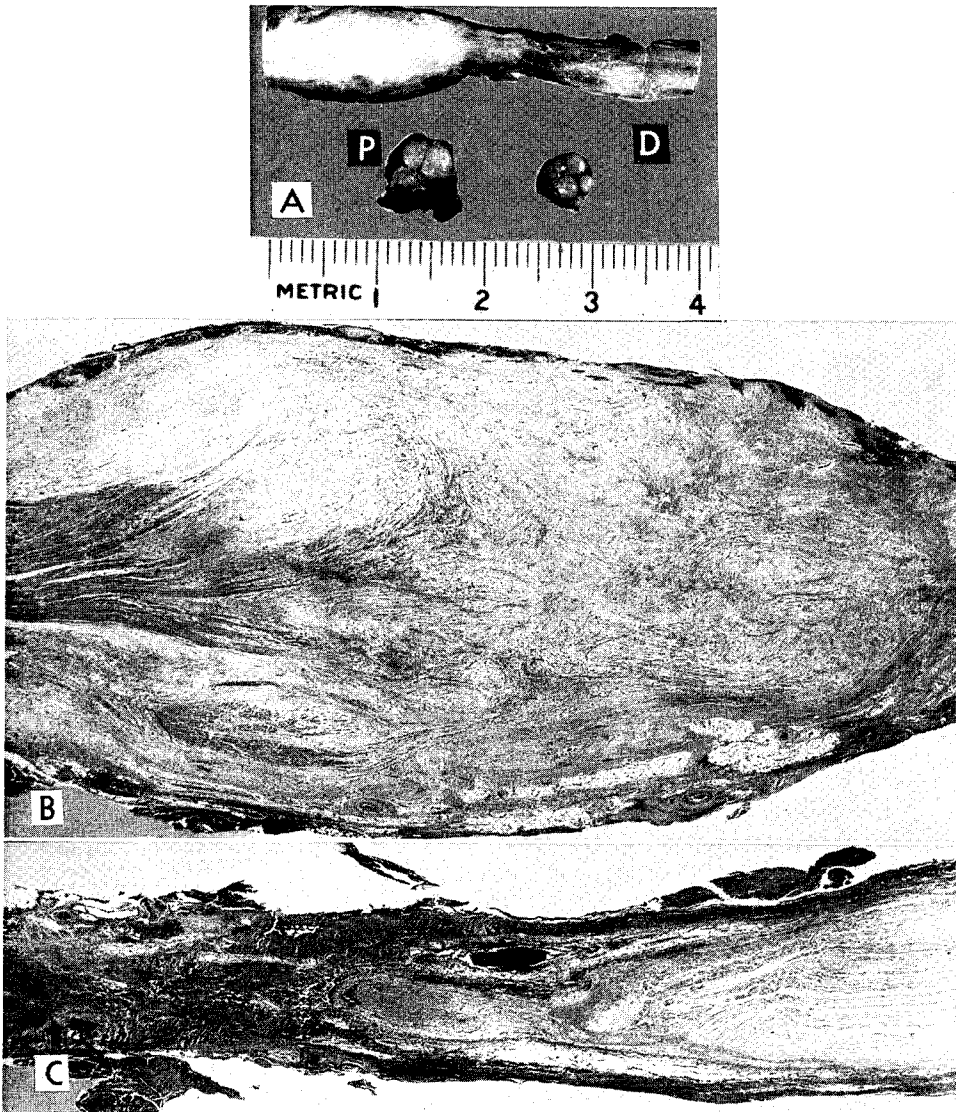

FIGURE 245.—Neuroma of ulnar nerve. A. Median longitudinal and cross sections of ulnar nerve incompletely severed by rifle bullet $2\frac{1}{2}$ months earlier. (P, proximal; D, distal.) ($\times 1.5$) B. Median longitudinal section through proximal segment from nerve shown in A, showing region in which fascicles break up to form neuromatous bulb. ($\times 9$) C. Median longitudinal section through distal segment and fibrous isthmus connecting it with proximal segment. Section is from nerve shown in A. A few nerve fibers had grown through the isthmus and penetrated the degenerated distal tubules. ($\times 9$)

The neuromas in continuity were valuable in studying the regenerative capacity of injured or severed axons (color plates 8, 9, and 10). In some instances it was possible to compare, in the same section, axons that appeared normal throughout the lesion and those that had undergone degenerative changes for several centimeters proximal to the main site of injury and had already sent regenerative sprouts through to the distal segment. With the date of injury known, it was possible to evaluate the various phases of degeneration and regeneration in relation to time.

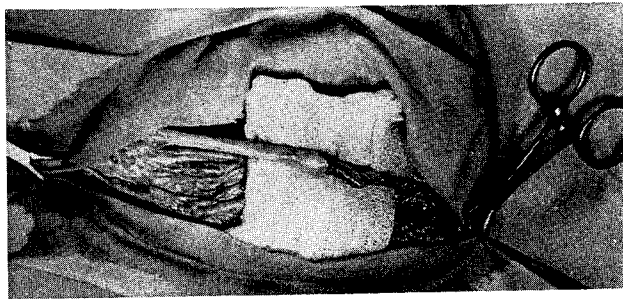

FIGURE 246.—Surgical exposure of median nerve injured above elbow by rifle bullet 2 months earlier. After removal of the neuroma in continuity and neurorrhaphy, nerve regeneration took place at a rate of 2.4 mm. per day, and within 6 months function had returned to all the muscles supplied by this nerve except the opponens pollicis.

As in the cases of complete severance, a series of photomicrographs of sections of distal fascicles was prepared and was used in two ways, as follows: (1) As a supplement to the other series in a study of the influence of time on degenerative changes, and (2) to learn something about the fate of numerous fibers regenerating through the main site of the lesion. In most of the cases in which a complete neuroma in continuity was resected, electrical stimulation of the nerve distal to the lesion elicited a painful, but never a muscular, response. Histologically, all such distal segments showed varying numbers of regenerating fibers, most of which were amyelinated and of very small caliber.

Probably the most significant finding in these cases was the lack of any appreciable myelination of the regenerating fibers, even after periods of several months. The sections shown in figure 254A, B, and C were prepared from an ulnar nerve that had been lysed 4 months after injury and then, after an unavailing wait of 6 more months, reexplored with resection of the neuroma in continuity. The lesion was near the wrist, and 10 months should have been ample time for functional regeneration of nerve fibers. Fibers had regenerated through the badly scarred zone of contusion, as is evident in figure 254A and B. That these fibers had not myelinated is demonstrated in a section through a distal fascicle (fig. 254C), in which fine axis cylinders



FIGURE 247.—Longitudinal section through neuroma in continuity of ulnar nerve contused by bone splinters from fractured ulna. Besides the main fragment of bone, which appears to have proliferated and which possesses a marrow, many smaller splinters were found throughout the neuroma. ($\times 30$)

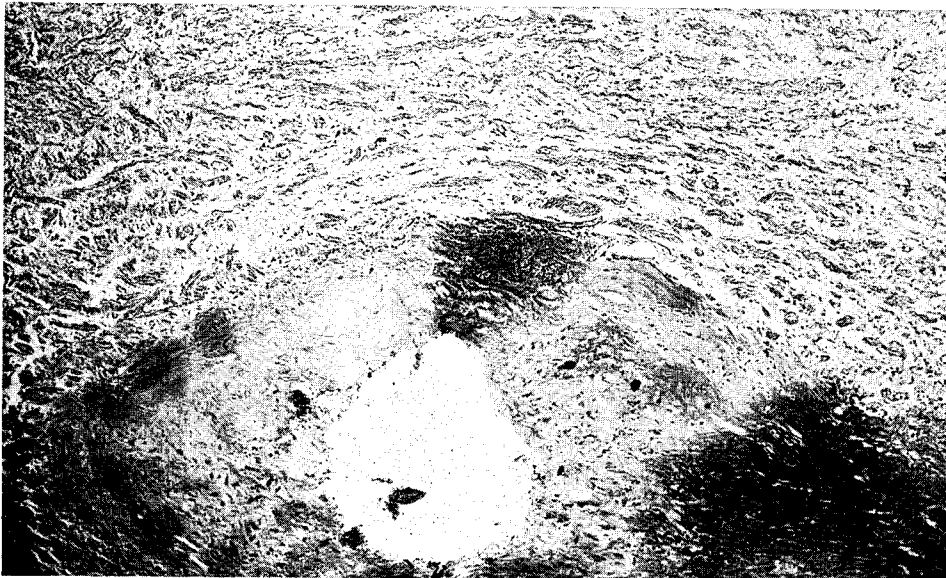

FIGURE 248.—Longitudinal section through neuroma in continuity of ulnar nerve in which small brass fragment was found. A dense fibrous capsule had formed around the fragment, and beyond this, on all sides, the regular nerve fascicles had been replaced by a neuroma made up of scar tissue and multiple small crisscrossing nerve fiber groups. ($\times 62$)

may be seen enmeshed in an endoneurial fibrosing process. In this case, it seemed likely that the main factor contributing to the failure of distally growing fibers to mature properly was fibrosis in the contusion zone. From this and other cases, it was concluded that a densely collagenous envelopment of the regenerating axis cylinders in the neuromatous zone usually precludes functional development of such fibers even though they gain access to patent distal tubules.

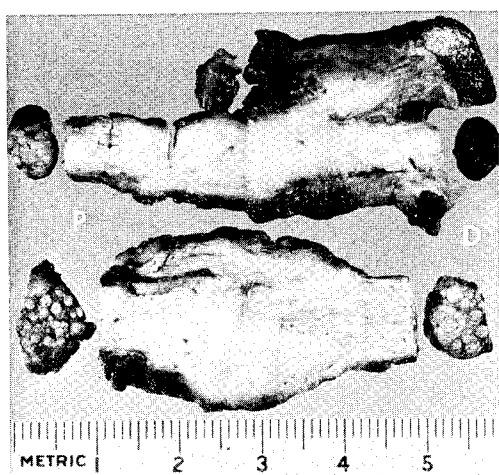

FIGURE 249.—Proximal (P) and distal (D) cross sections and median longitudinal sections of common peroneal (upper) and posterior tibial components of sciatic nerve showing large neuromatous areas contused by displaced end of femur fractured by shell fragment 4½ months earlier. ($\times 1.1$)

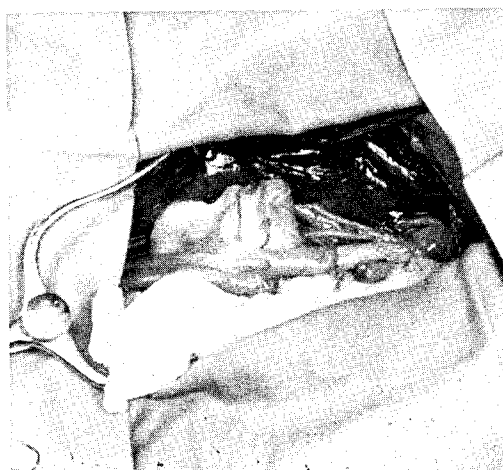

FIGURE 250.—Sciatic nerve contused 3½ months earlier by machinegun bullet. Only the common peroneal component was badly damaged. It was excised as shown, and its ends were approximated by knuckling the posterior tibial component.

Attention is drawn to the better blood supply in the distal segments of the neuromas in continuity as contrasted with that of the severed distal stumps. In the former, the fascicles of both stumps appeared succulent and there was little or no disparity in cross sectional areas when surgical sections were made at the proper levels. In completely severed nerves, the distal stump fascicles were always shrunken and never edematous, as in the proximal stump, and thrombosed, sclerotic vessels were generally observed in them.

NERVE SEGMENT ERODED BY ANEURYSM

The finding of only a single nerve eroded by an aneurysm among a group of 228 resected nerve specimens should not be construed as indicating the true incidence of such associated lesions. The probable explanation is that patients with combined nerve-vascular injuries were assigned to other

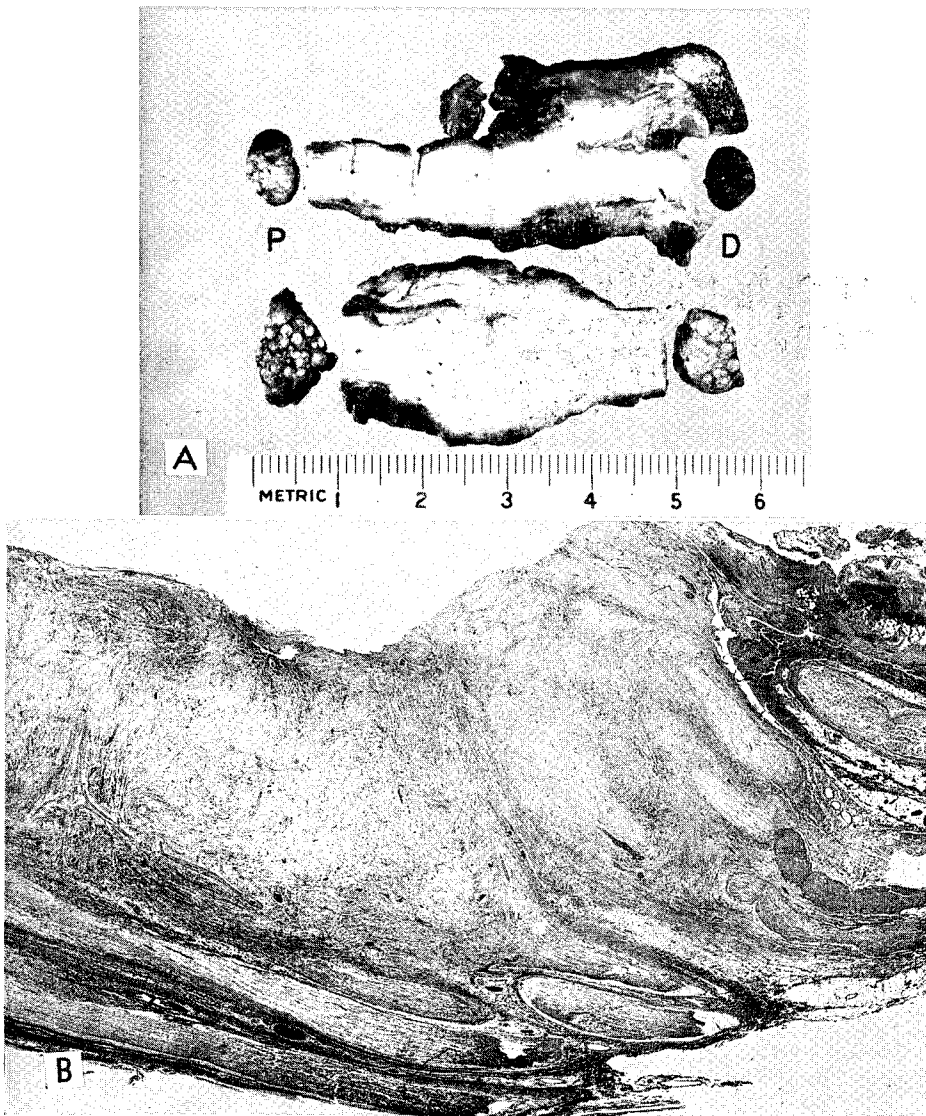

FIGURE 251.—Neuroma in continuity of common peroneal nerve. A. Median longitudinal and cross sections through neuroma in continuity of common peroneal nerve partly severed by mortar shell fragment $2\frac{2}{3}$ months earlier. ($\times 1.5$) B. Longitudinal section through middle and distal parts of specimen shown in A. All but two fascicles were destroyed, and they were found to be compressed between the hard fibrous neuroma and dense epineurial adhesions. ($\times 9$)

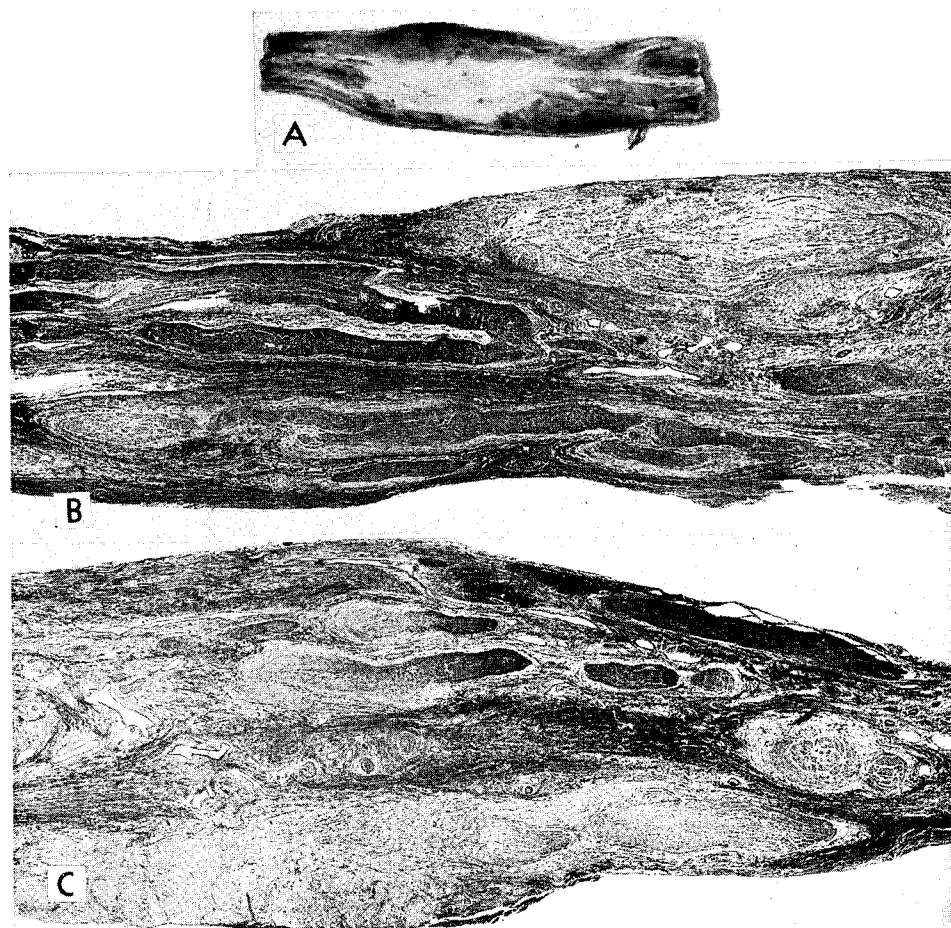

FIGURE 252.—Fusiform neuroma in continuity of ulnar nerve. A. Sections through median longitudinal plane of fusiform neuroma in continuity resected from ulnar nerve contused by mortar shell fragment $2\frac{1}{4}$ months earlier. B. Proximal section of specimen shown in A. All fascicles are seen to have been torn or interrupted. C. Distal longitudinal section. All tubules are in process of resorption, and some show ingrowth of nerve fibers regenerating at random through the neuroma. ($\times 9$)

centers. This specimen of radial nerve (fig. 255A, B, and C), however, is typical of the cases seen elsewhere. The sacculated aneurysm in the wall of the axillary artery had deeply eroded the radial nerve and rendered it completely functionless. All but two fascicles in the lateral epineurial region had been separated and destroyed by the erosional beat of the artery. The nerve fibers in the main site of damage, and even in the two fascicles remaining in continuity, had undergone degeneration, and a futile attempt at regeneration on the part of some of the nerve filaments (fig. 225C) was seen in the scar tissue around the crater.

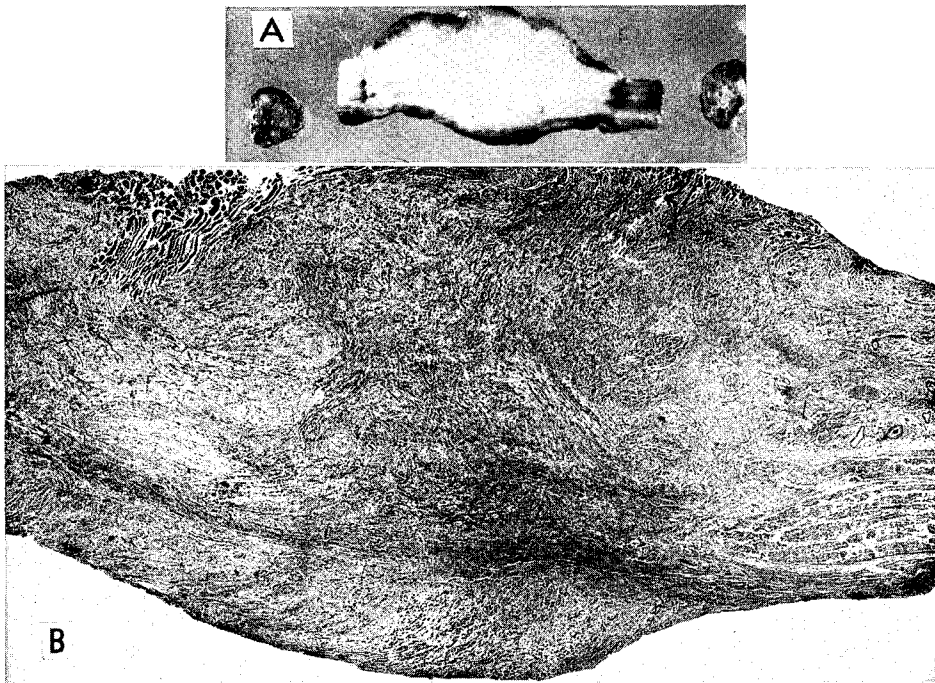

FIGURE 253.—Neuroma in continuity of ulnar nerve. A. Median longitudinal and transverse sections of ulnar neuroma in continuity resected 6½ months after shell fragment wound. The ulna was also fractured. ($\times 1.5$) B. Longitudinal section through central part of neuroma shown in A. Fascicles have been replaced by small bundles of regenerating nerve fibers growing at random amid the scar tissue, especially in the epineurial regions in which muscle and adhesions are seen. ($\times 9$)

Fifty-three days had elapsed since the injury was sustained, and it is noteworthy that the patient came to surgery with a diagnosis of radial nerve palsy and not of aneurysm, possibly because the radial pulse had always been detectable, whereas bruit in the axilla had not been. Nerve ends showing good fascicular pattern were obtained after resecting a 30-mm. specimen. Evidence that such patients may be expected to show good progress is found in the fact that within 3½ months after suture, an 8-inch (20-cm.) advance in Tinel's sign and beginning function in the triceps muscle were observed.

SUTURE SITES

Classification and timelag.—A group of 57 resected suture sites in a series of 228 nerve specimens may seem disproportionately large, but about half of the specimens should probably be classified as temporary coaptations. Adequate histories available for 29 specimens permitted the following classifications:

1. Definitive suture was performed in seven instances within 2 days of injury, and in seven within 20 days to 11 months.

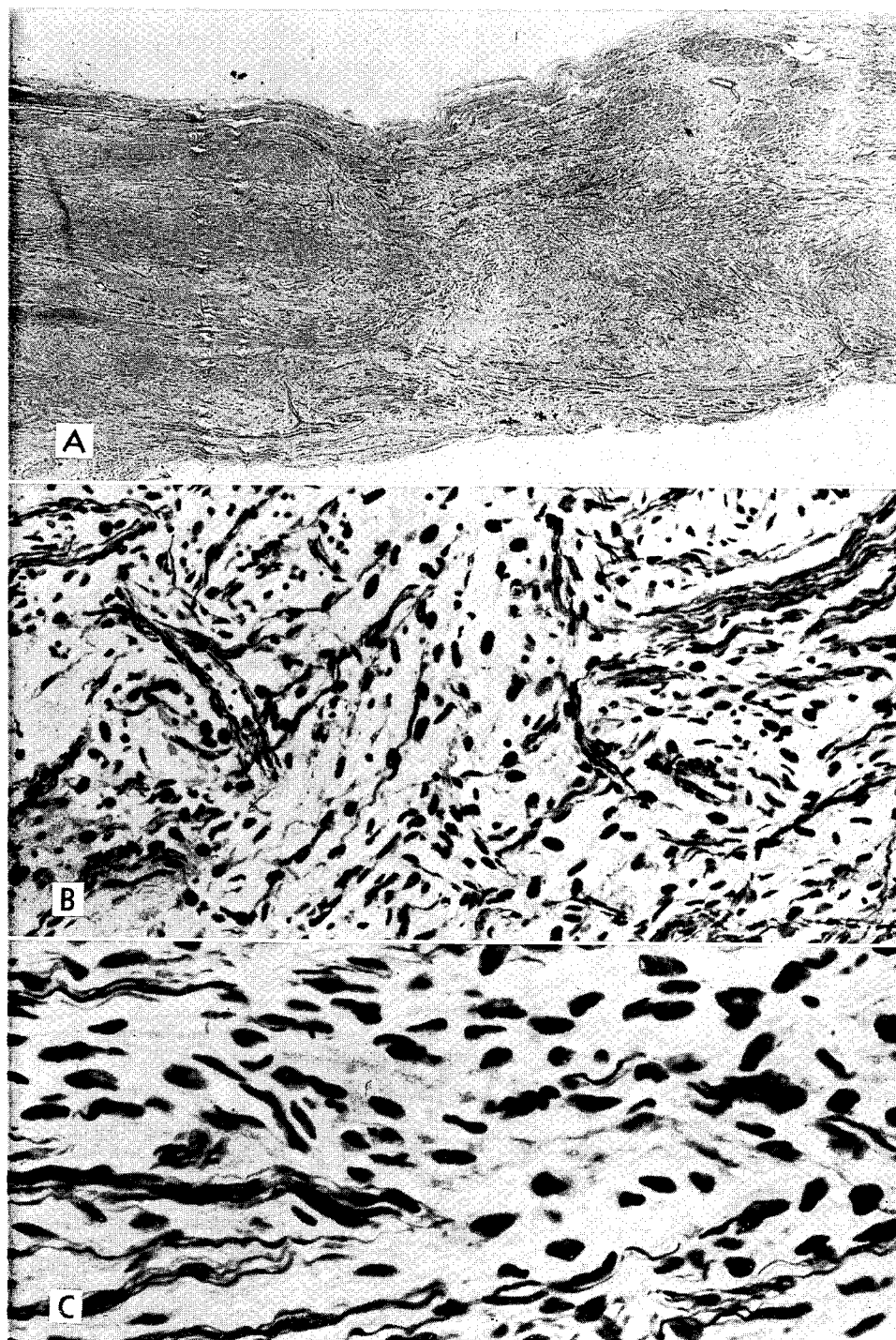

FIGURE 254. (See opposite page for legends.)

2. Disruption occurred in seven other instances of definitive suture.
3. Temporary suture was performed in five instances from 1 to 10 days after injury.
4. Bulb suture was employed in three instances.

The remaining 28 specimens were obtained from cases in which there was either no record of suture or insufficient data for determining whether the suture was intended as temporary or definitive. By the use of such notes as were available, as well as on the basis of gross and microscopic appearance of the specimens, 4 of these 29 specimens were arbitrarily assigned to a probably definitive class and 24 to a probably temporary class. In 8 of the 28 questionable cases, notations on the Field Medical Record were to the effect that a nerve suture had been done (7 within 2 days of injury and 1 on the 11th day). The records in the remaining 20 cases contained no evidence that neurorrhaphy had been done, and it was only an assumption that the suture material found in these specimens had been placed there at the time of debridement, or, less likely, at closure.

In 11 of the 28 cases without notes or adequate descriptions of procedure, the severances were found to be only partial, and it is possible that the few approximating sutures used may have been considered adequate and definitive at the time of debridement. This has not been assumed in classifying them. The single case in which a nerve was accidentally severed at debridement was accompanied by a note indicating that temporary sutures had then been placed.

Suture material.—From this heterogeneous group of 57 specimens of suture sites, there was gleaned considerable information helpful in the general problem of nerve suturing. Opportunities for observing the tissue reactions to various types of suture material were particularly useful. The finest available silk, nylon, cotton, or linen all caused the typical foreign body giant cell and fibrous reaction (fig. 256); in specimens removed a year or more after suture, extensive reactions were still very much in evidence. It was learned that naming needles atraumatic and threading them with the finest tantalum do not make them any less injurious to the tissues impaled upon them (figs. 257 and 258). When suture material involved fascicles instead of epineurium, nerve fibers were either destroyed by a severe fibrosing process

FIGURE 254.—Neuroma in continuity of ulnar nerve. A. Median longitudinal section through neuroma in continuity resected from ulnar nerve contused by bullet 10 months earlier. Neurolysis had been performed on this nerve 4 months after injury, without effect. No intact fascicles were present in the midsegment, in which a hard fibrous neuroma had formed. ($\times 9$). B. Higher magnification of midsegment seen in A, showing disarray of fine nerve fibers attempting to regenerate through dense collagenous tissue. ($\times 250$) C. Longitudinal section through fascicle of distal stump of nerve shown in A. Nerve fibers sparsely distributed among collagenous tissue are seen to have grown through the zone shown in B. A few fibers have become thickened, and others have formed braids, but, in the 10-month interval, none have properly matured. ($\times 600$)

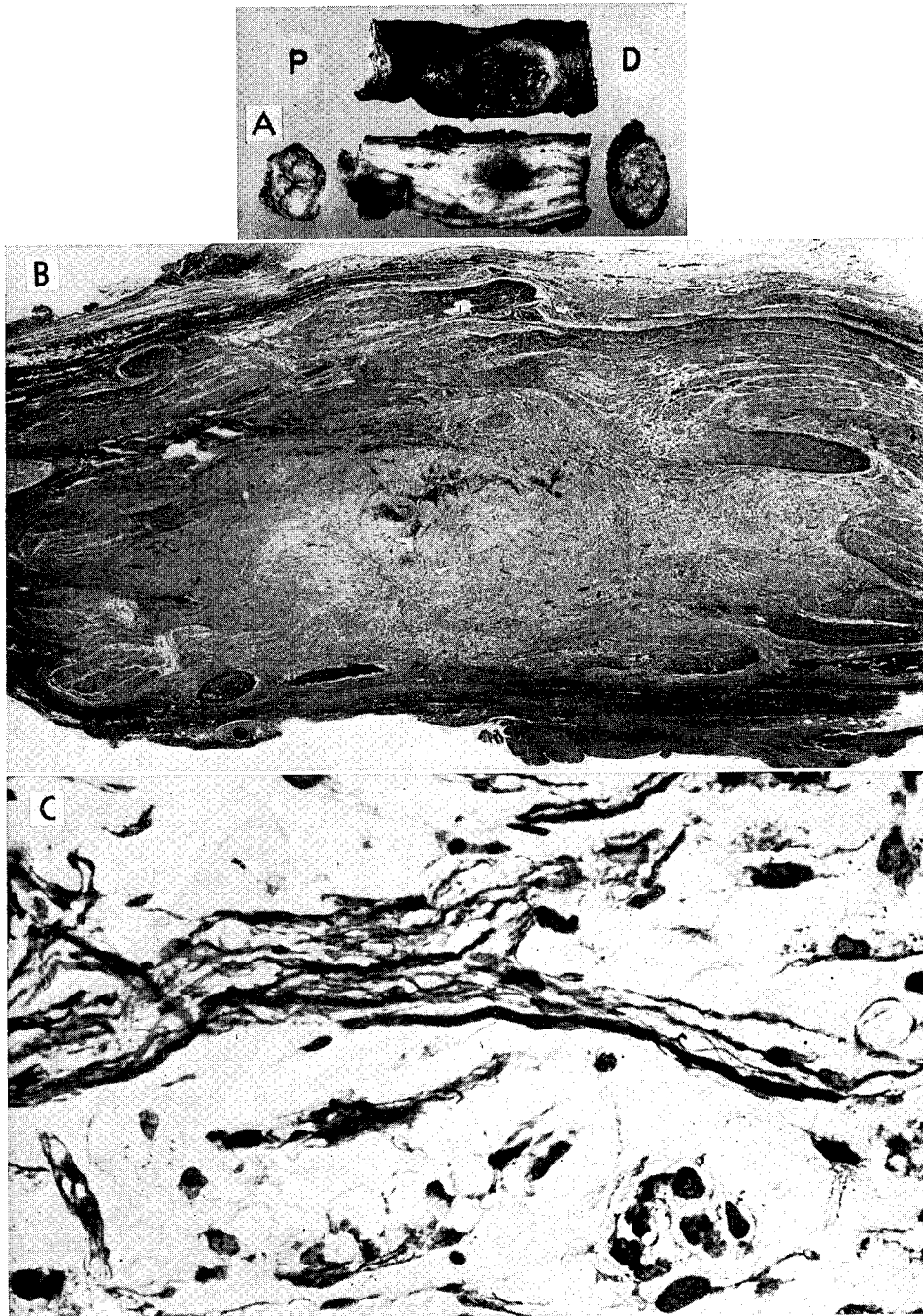

FIGURE 255. (See opposite page for legends.)

or were so altered as to form an intrafascicular neuroma (fig. 258). The reaction around tantalum sutures as well as around foil (fig. 259A and B) was largely one of fibroblastic proliferation and collagenation.

When properly prepared tantalum sleeves (rolled from 0.0005 inch foil and tempered at 900° F. for 2 minutes in an oven) were removed from anastomotic sites several months after placement, it was noticed that a smooth epineurium had sheathed the nerve and that a new, grayish-white membrane had covered the outer surface of the sleeve (fig. 259A and B).

A few cases were included in this series in which fibrin film had been placed around suture sites. The findings corroborated those of the Walter Reed General Hospital series studied in 1944, when fibrin film had proved to be a failure as a wrapping material for nerves. Extremely dense epineurial scar tissue was always associated with the fibrin film used at that time, and, as may be seen in figure 260A and B, the material remained in situ and caused a typical foreign body reaction. In figure 260A, the complete destruction of nerve fascicles by a temporary silk sling stitch is also shown.

Influence of timelag.—A study of the influence of the time lapse on the endoneurial fibrosing process in the distal tubules of the sutured nerve stumps repeatedly emphasized the importance of early neuroorrhaphy. Many of the specimens of suture sites were obtained 5 months or longer after the original neuroorrhaphy, and although most specimens showed some neurotization of the distal stump, the gradual fibrous replacement was very much in evidence after the longer intervals (figs. 261 and 262). The regenerating fibers in these cases remained fine in caliber or degenerated after being choked by collagenous tissue.

Even greater significance was attached to the more pronounced, diffuse fibrosis in the midst of the neuromatous proliferation in the suture zone. This was considered to be the main reason for the failure of regenerating fibers to gain access to patent distal tubules and for the failure of most of the fibers that had penetrated the distal tubules to maintain themselves.

Somewhat similar pictures were seen in the central regions of the suture-line neuromas that developed in nerves sutured at the time of injury and in those sutured secondarily, but with inadequate resection. Figure 263A, B, C, D, and E are illustrations of a typical suture-line neuroma resected from

FIGURE 255.—Erosion of radial nerve by aneurysm. A. Specimen of radial nerve eroded by aneurysm. External view (above) shows craterized portion and fibrous adhesions around the point of injury. Below are seen the proximal (P) and distal (D) cross sections showing good fascicular pattern and a median longitudinal section with portions of the destroyed fascicles. ($\times 1.2$) B. Longitudinal section through the eroded region seen in A. Peripheral to the central scar tissue are the ends of segments of fascicles surrounded by fibrous reaction. ($\times 9$) C. Higher magnification of portion of mid-segment shown in B. Fine anastomosing or braided nerve fibers have attempted to regenerate in the midst of scar tissue and old tubular remnants. Large macrophages filled with fat and other debris are also present. ($\times 600$)

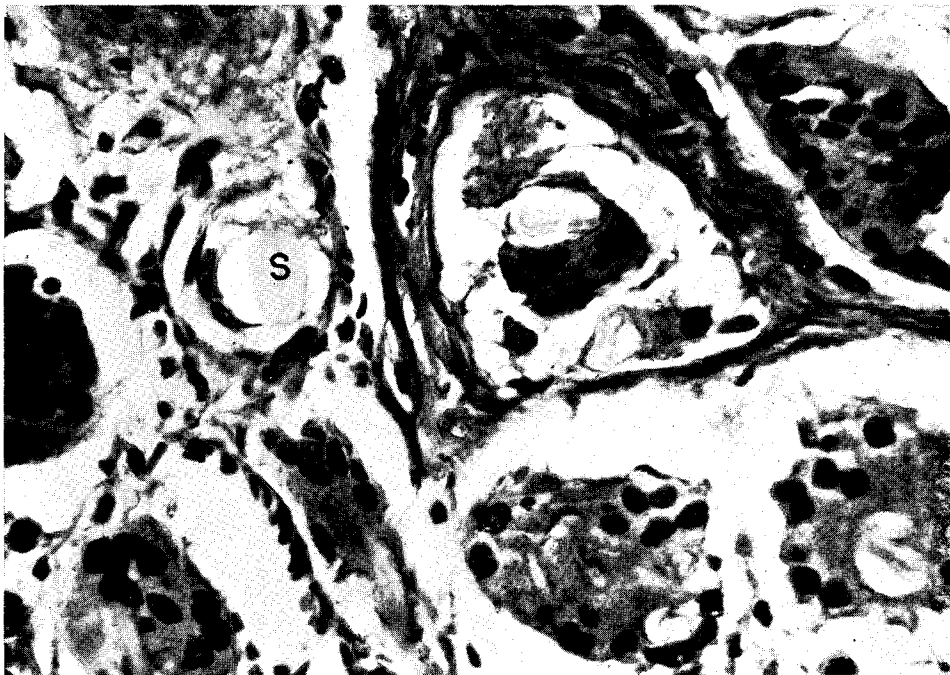

FIGURE 256.—Giant cell and fibrous reaction around fibers of silk (S) used in suture of severed ulnar nerve. ($\times 600$)

an ulnar nerve sutured within 24 hours of severance. It was concluded from a study of these early sutures that it must have been almost impossible for the surgeon to foretell, on the day of injury, how far the pathologic process would extend along the nerve stumps. In the case illustrated, another 5 cm., at least, should have been excised at the first operation, in order to have excluded most of the contused nerve from the suture site. That a good proximal cross section was not attained even at the second neurorrhaphy is shown in figure 263E.

Observations have proved that the granulation and scar tissue response to nerve contusion becomes fairly well demarcated within 3 weeks. Microscopic examination of a series of transections of the stumps of nerves damaged 3 weeks or more earlier usually revealed that intraneural changes such as fibrosis, edema, hemorrhage and thrombosis, neuromatous proliferation within or between fascicles, and sheath distortion had extended for at least 1 cm. above and below the points of obvious gross pathology. From this, it would seem to follow that surgeons who advocate the urgency of immediate suture should be prepared to resect as much stump above and below the main site of injury as would be compatible with a good coaptation without undue tension after transplantation, rerouting, complete mobilization, and joint posturing. This is mentioned because it is one of the common

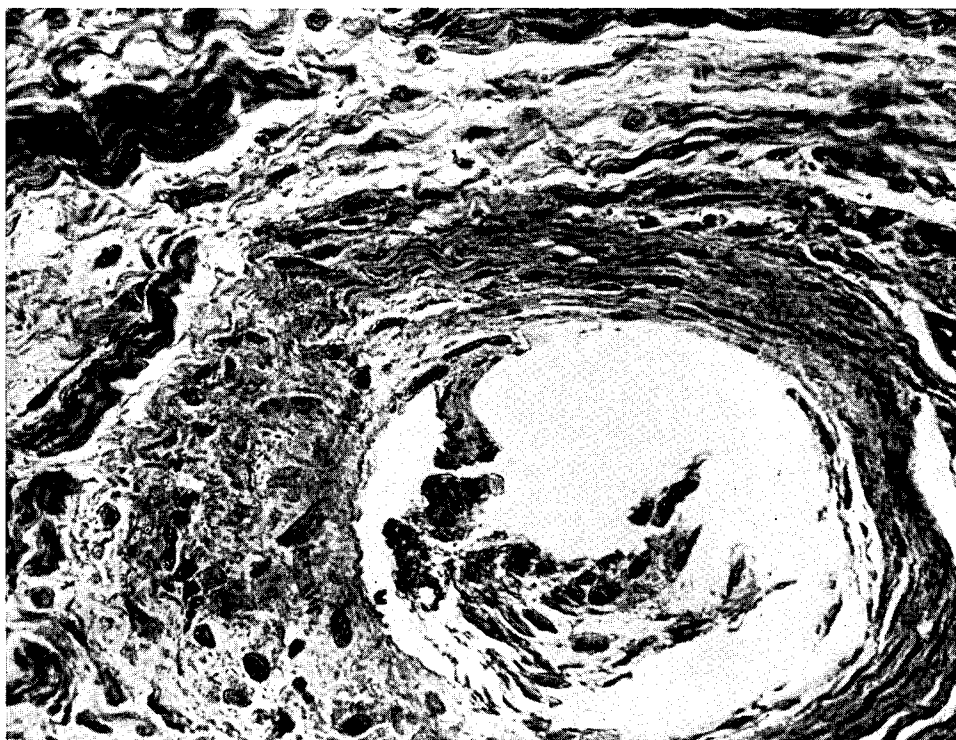

FIGURE 257.—Fibrous reaction around site from which tantalum sling stitch was removed. The tantalum had been placed in the ulnar nerve at suture 4 months earlier. Note small bundles of regenerating nerve fibers above and to the left. ($\times 480$)

questions asked a pathologist, who is just as helpless as the surgeon in predicting on the day of injury how far the effects of the trauma will eventually extend.

Failure of neurorrhaphy.—The reason for failure of some of the secondary neurorrhaphies in this series was not so much the inability to recognize the extent of the lesion as the lack of other methods of obviating it, after all of the usual maneuvers had been resorted to. There were only a few cases, however, in which, at a previous secondary neurorrhaphy, the surgeon had been unable to avail himself of all of the accepted methods of gaining nerve length in order to resect adequately, and, in consequence, had been faced with the task of suturing a large edematous neuroma to a shrunken, fibrotic distal stump. One of the results of such a suture is shown in figure 264, in which a neuromatous rind has grown over a distal stump that had been coapted to a proximal neuromatous stump with over 100 percent greater cross sectional area. The region shown was enclosed within a tantalum cuff, and, beyond this point, the distal stump had a cross sectional area equivalent to the central fasciculated region.

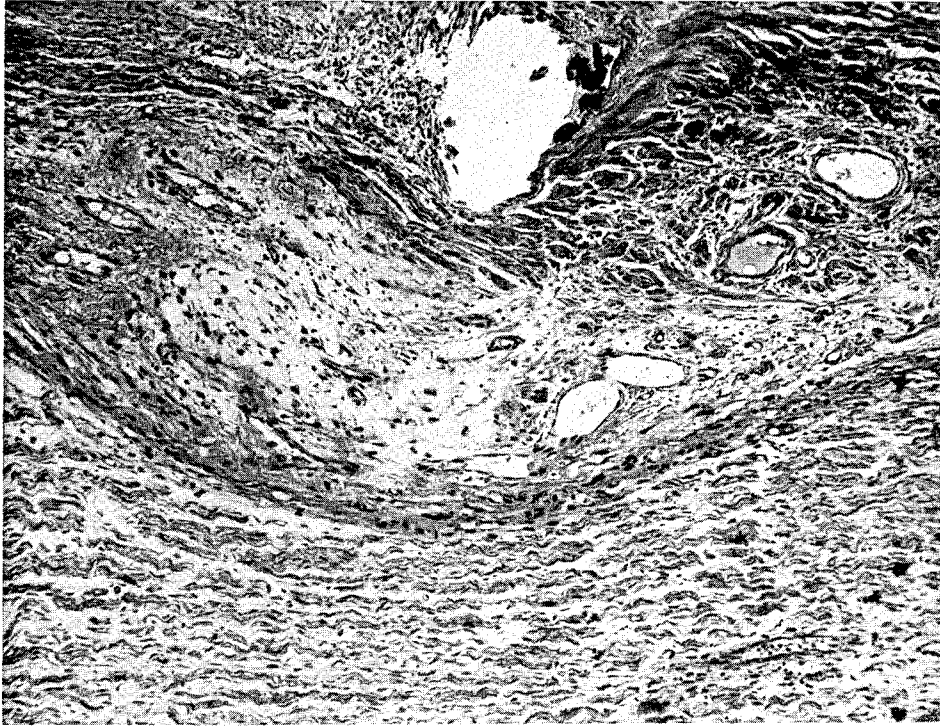

FIGURE 258.—Median longitudinal section through suture site of median nerve severed by gunshot wound and sutured on day of injury, 11 months before reexploration and resection. The scar tissues around the site from which the tantalum suture was removed had replaced about half of the fascicle shown here. Small bundles of regenerating nerve fibers are seen below. ($\times 115$)

Three of the specimens obtained from nerves in which secondary neurorrhaphy had failed were somewhat the worse for ill-placed sutures, and, in each instance, a tantalum sling stitch was found in the middle of the nerve surrounded by dense scar tissue (fig. 259A).

Temporary suture.—A typical case in which temporary suture was done in a severed median nerve at the time of debridement and in which secondary neurorrhaphy was performed 2 months later is illustrated in figure 265. Upon resection of the 35-mm.-long specimen (fig. 265A) representing the neuromatous bulb (fig. 265B) and the glioma in continuity, it was possible for the surgeon to attain relatively good ends (fig. 265C and D). Both cross sections showed a moderate amount of interfascicular fibrosis and thickened epineurium.

Sections through the proximal segment showed that the nerve had been resected to a region in which well-myelinated and regenerating axis cylinders were in evidence (fig. 265E and F). Distally, the fascicles were found to be slightly edematous, and most of the tubules had remained unshrunk.

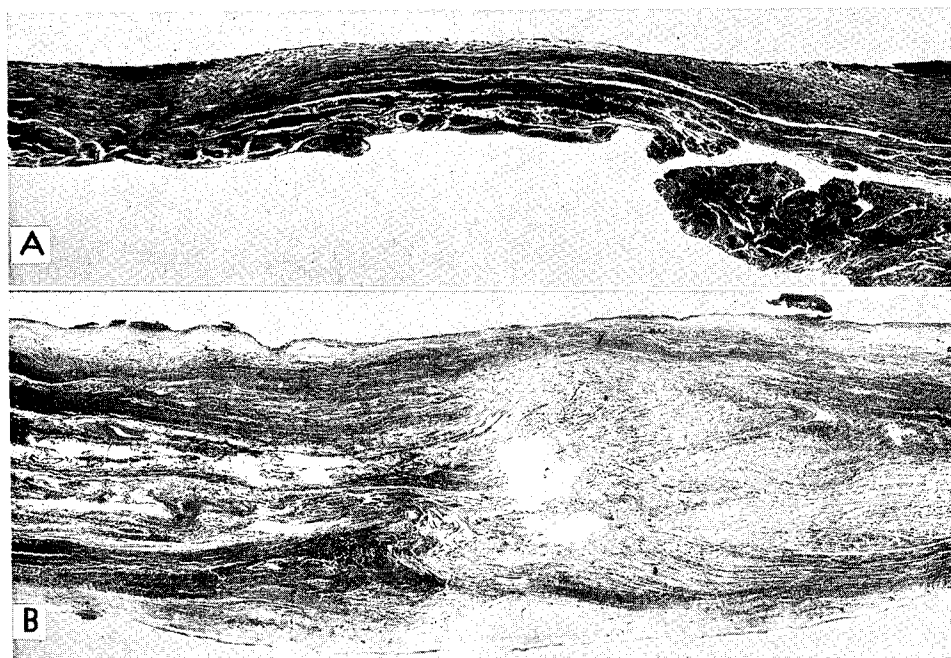

FIGURE 259.—Anastomotic zone of common peroneal nerve after suture with tantalum wire. A. Median longitudinal section through anastomotic zone of common peroneal nerve sutured 2 months earlier by tantalum sling stitch. The rents in the tissue were made in removing the tantalum wire. The dark central areas represent the fibrous reaction around the sling stitch. Note that smooth fibrous epineurium has formed under tantalum sleeve placed around anastomoses. ($\times 8$) B. Section of new fibrous membrane formed over tantalum sleeve used around anastomotic zone shown in A. ($\times 30$)

Macrophages were still engaged in clearing out the products of degeneration, and finely braided regenerating nerve fibers had succeeded in penetrating a few of the tubules for a distance of at least 17 mm. beyond the point of severance (fig. 265G and H).

Influence of position.—Some of the bulb-suture specimens provided opportunities to study the effects of suturing uncut nerve stumps with the limb in flexion and subsequently extended. This positioning represents the first phase of a two-stage stretching procedure designed to allow the surgeon to resect the pathologic segments and finally bring together fairly satisfactory nerve ends. The specimen shown in figure 266 was obtained from a common peroneal nerve and is an example of the stretch fibrosis that may develop in the region of the nerve immediately involved. This is seen to be especially true of the proximal stump, in which extremely dense fibrosis was found instead of the usual neuromatous proliferation.

Disruption of suture site.—Two nerve disruptions after suture were of particular interest. In the first case, a neuroma in continuity had been resected from a radial nerve $2\frac{2}{3}$ months after injury, and the arm had been

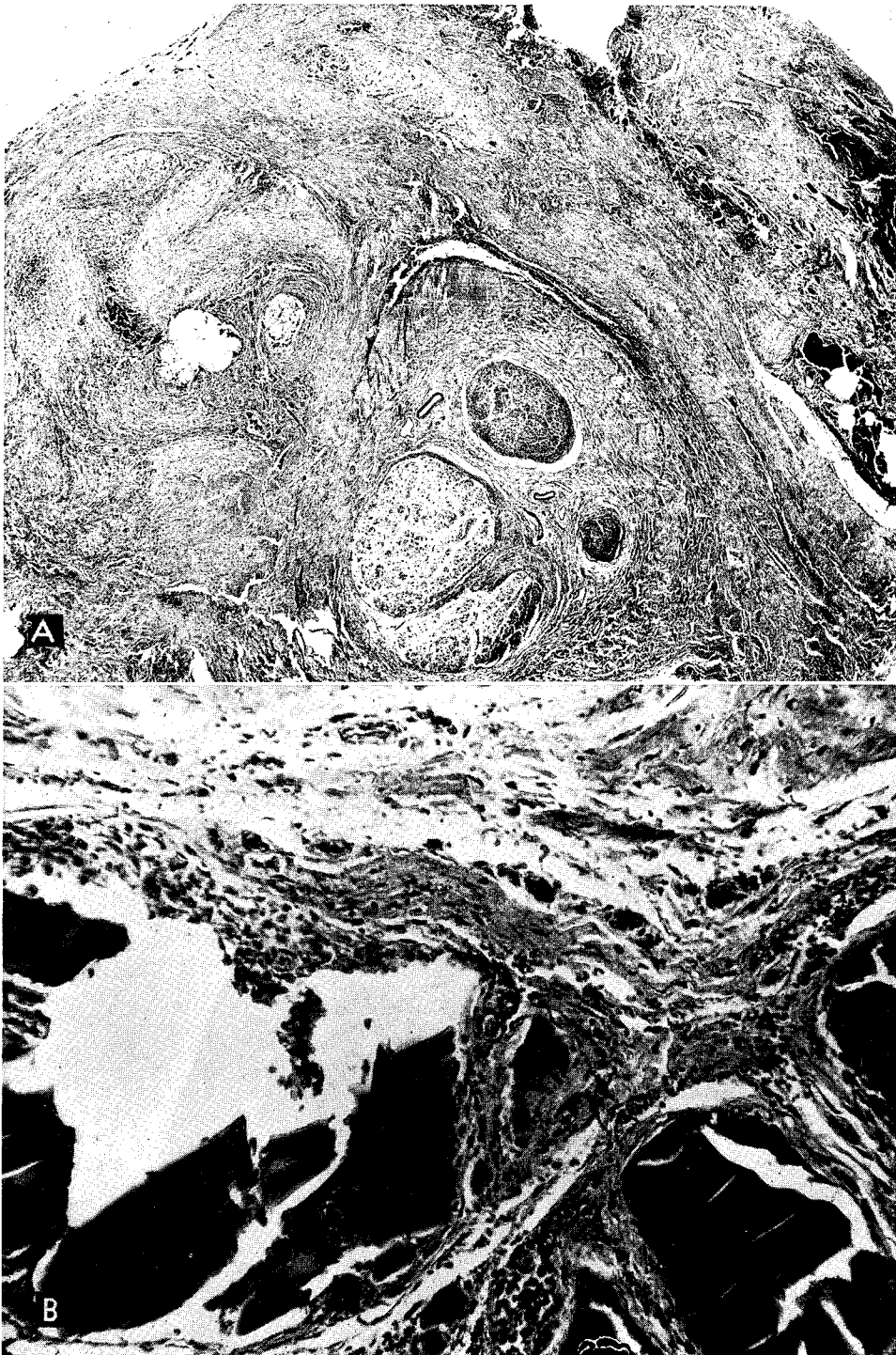

FIGURE 260. (See opposite page for legends.)

flexed in a cast for only 16 days, when, due to an accident, the elbow was extended and the suture zone disrupted. Figure 267A shows the gross specimen obtained from this nerve, and figure 267B and C shows the topographic view of the distal and proximal stumps, respectively. At surgery, a badly distorted tantalum sleeve was removed from the fibrous isthmus connecting the greatly enlarged and neuromatous bulb to the shrunken and fibrotic distal segment.

In the second case, the common peroneal nerve had become separated after neurorrhaphy, with maintenance of fibrous strands between the stumps (fig. 268A). In the 36-day interval between the first and second operations, fine nerve filaments had grown from the region of neuromatous disarray in the proximal stump (color plate 11) through the fibrous isthmus and into a narrow portion of a distal fascicle (fig. 268B). The rate of growth, about 30 mm. in slightly over a month, is considerably less than that observed in many favorable cases (2.5 mm. per day) but is an example of a growth rate under extremely adverse conditions.

ADDITIONAL STUDIES

Stretch Fibrosis

Supplementary to this series of cases, a specimen was obtained that was considered to be typical, nonsevered, stretch lesion (fig. 269A). It was obtained from a soldier who had experienced a knee injury when a log fell across his leg. Other specimens diagnosed as stretch lesions were seen at surgery, with densely fibrotic changes over distances too great to be made up if adequate resection were done. In such cases, it was usually possible to demonstrate by electrical stimulation that some sensory fibers had remained in continuity or had regrown through the fibrotic segment. Since it was impossible, however, without biopsy, to diagnose the precise extent of the damage, the nerve was merely lysed from the bed of scar tissue in preference to inserting a graft. It was realized, from previous histologic studies of resected stretched nerves, that little hope could be entertained for good regeneration through these palpably fibrotic segments.

Other specimens were obtained from nerves showing what appeared to be stretch fibrosis associated with severed, or partially severed, and contused nerves. Rather extensive fibrotic lesions in continuity were found in radial

FIGURE 260.—Temporary repair of radial nerve with silk sling stitches and wrapping of fibrin film. A. Cross section through distal stump of severed radial nerve sutured temporarily with silk sling stitches and wrapped with fibrin film. Fascicles have been replaced by scar tissue in left half of section through which silk passed. On the right, fibrin film fragments are embedded in a dense epineurial fibrous reaction. ($\times 16$) B. Higher magnification of fibrous and giant cell reaction around fibrin film in nerve shown in A. ($\times 230$)

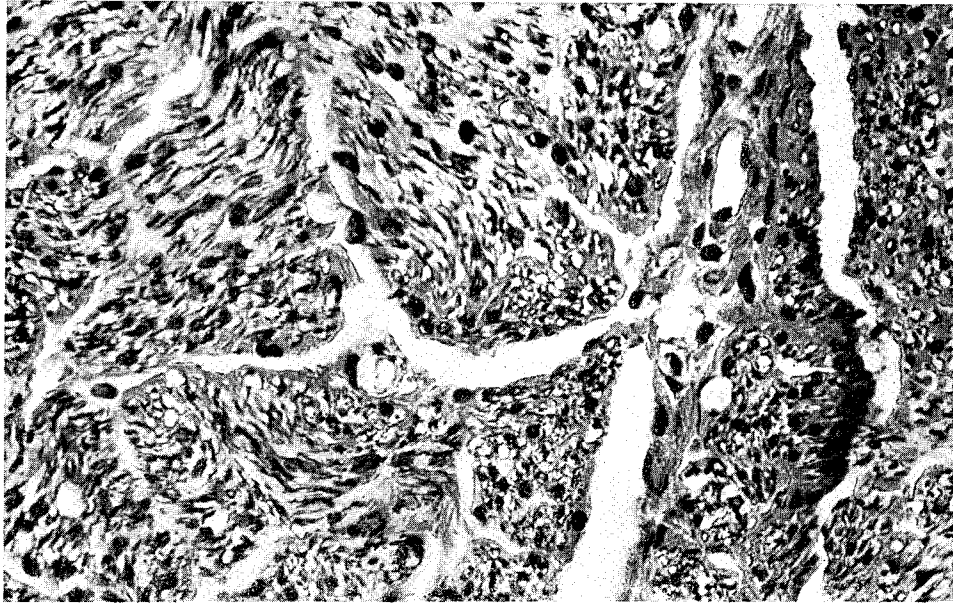

FIGURE 261.—Cross section through fascicle of distal stump of radial nerve sutured 6 months earlier, 4 months after severance. Tubular shrinkage and fibrous replacement are marked. Some of the small black dots in the tubules represent regenerated, myelinated nerve fibers. ($\times 600$)

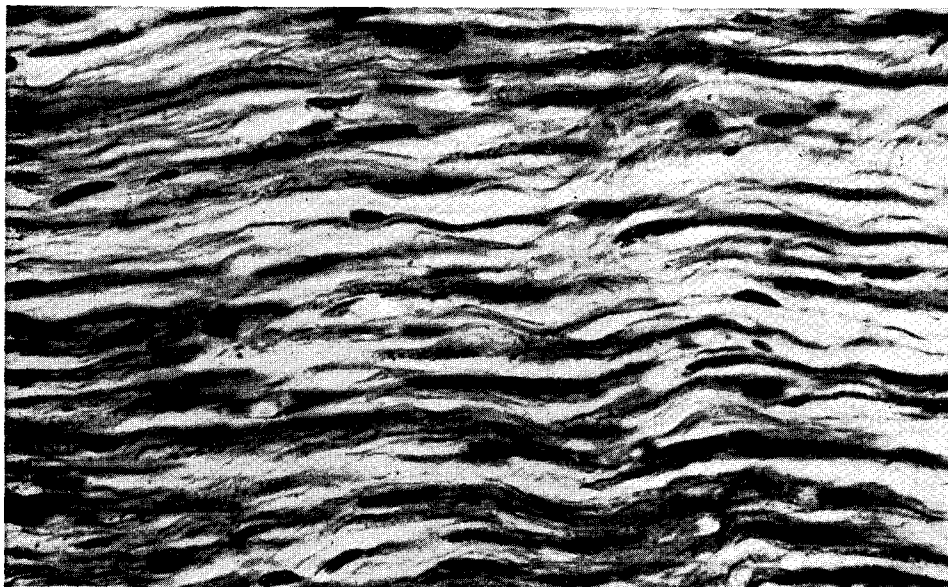

FIGURE 262.—Longitudinal section through fascicle of distal stump of ulnar nerve sutured 10½ months earlier, at time of injury. Most of the regenerated axis cylinders surrounded by collagenous tissue show granular degeneration. The suture site was also fibrotic. ($\times 600$)

nerves apparently lacerated and impinged upon by the edges of fractured humeri. The fibrosing effect of excessive stretch was also observed in segments of nerves in which bulb sutures had been done, with the limb flexed during the month following temporary stump union and then extended.

As shown in figure 269B and C, the typical histologic finding in a stretched nerve was the mass replacement of normal structures by fibrous tissue. The injurious force was sufficient to cause rupture of sheaths, nerve fibers, and blood vessels. There was evidence of intraneural hemorrhage and of a diffuse granulation reaction that subsequently changed to dense scar tissue. Nerve fibers remaining in continuity, as well as those attempting regeneration after disruption at different levels of the lesion, became choked in granulation and scar tissue, and many showed granular degeneration. The fibrous reaction surrounding such fibers as had escaped degeneration appeared to be sufficient to defeat myelination, and it seemed unlikely in such cases that any functions except those subserved by fine, amyelinated fibers would return.

Ischemia

No example of pure ischemia of a peripheral nerve was encountered in this series. From examples of peripheral nerve injury associated with vascular occlusion of the main vessel of an extremity studied at the Ashford General Hospital, White Sulphur Springs, W. Va., and from biopsy of ischemic nerves embedded in necrotic muscle, it is clear that considerable variations in the pathologic changes may exist. The process is easily studied experimentally as well. In minor degrees of ischemia, axonal and myelin degeneration will occur as simple nerve division. In the most severe degree of ischemia, with all tissues of the extremity affected, the involved nerve may show total cellular necrosis, particularly when it is studied from an area of necrotic muscle. Diffuse endoneurial collagenization may develop in less severe grades of ischemia; it is not unlike that visualized in distal tubule denervation of long duration. Such changes appear incompatible with any degree of functional nerve regeneration.

It was interesting to note, in a median nerve severed by gunshot simultaneously with the ipsilateral subclavian artery, that, after 9 months, the fascicular pattern was maintained throughout the nerve trunk; that a uniform and extreme degree of tubular resorption with dense fibrous replacement had taken place; that end organs had persisted with atrophic Schwann cells in their centers; and that revascularization had progressed well, as shown by the presence of many small collateral vessels.

Nerve Grafts

No specimens of nerve grafts were obtained during the period of the 4-month survey. Shortly after the series was completed, however, three

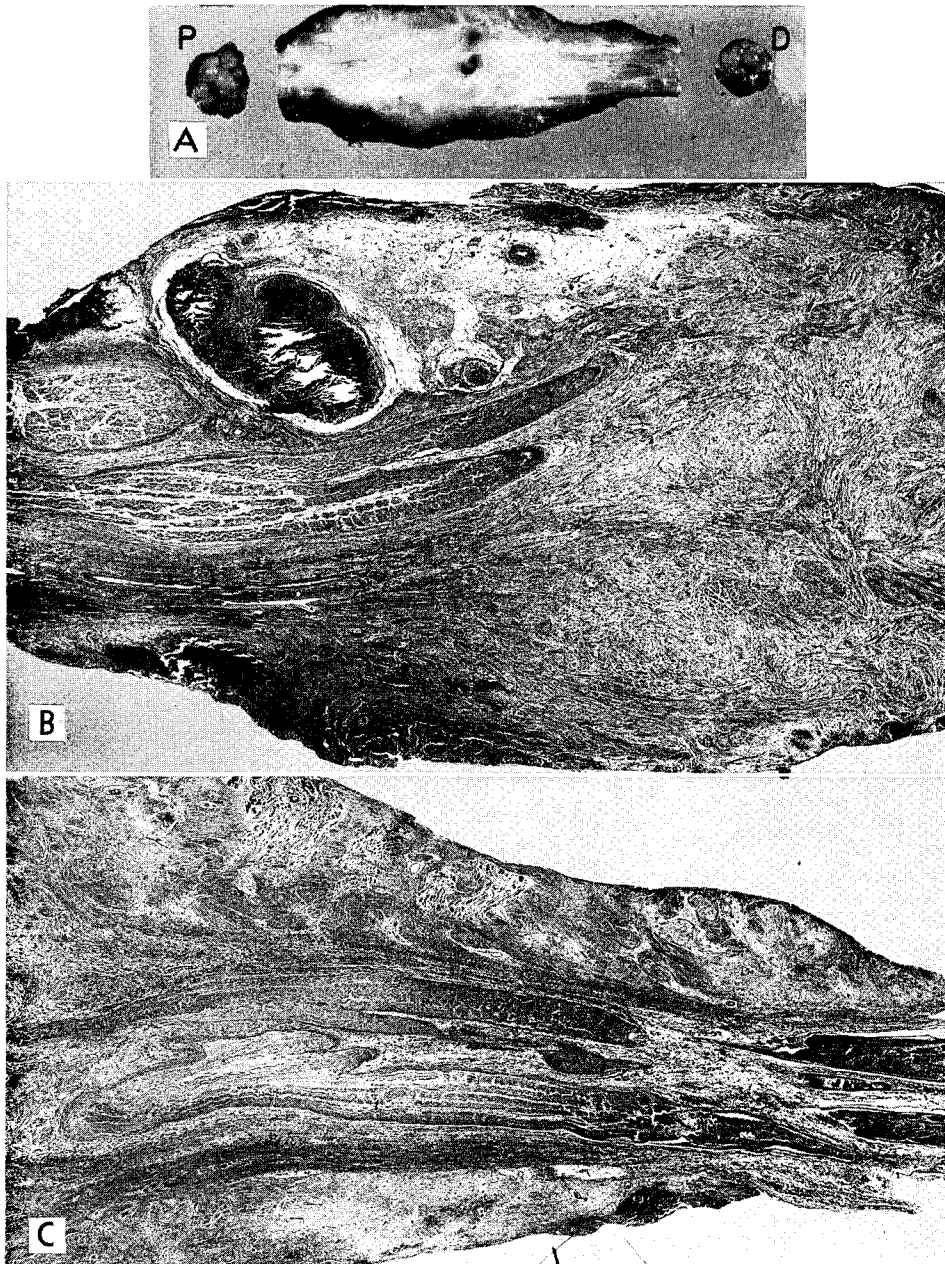

FIGURE 263.—Neuroma of ulnar nerve after repair in which resection was inadequate. A. Proximal (P) and distal (D) cross sections and median longitudinal section of ulnar nerve sutured $3\frac{1}{4}$ months earlier, 24 hours after severance. ($\times 1.5$) B. Median longitudinal section through proximal end of nerve shown in A. Note greatly thickened epineurium containing muscle fibers and adhesions. These stumps were not adequately resected at primary suture, and a hard, fibrous neuroma developed in the suture zone. C. Median longitudinal section through distal end of same specimen. ($\times 9$) D. Longi-



tudinal section through suture zone shown in A, B, and C. Small nerve bundles have grown in disorderly fashion into the scar tissue of the anastomosis. ($\times 600$) E. Transverse section through proximal stump of nerve shown in A. It is evident from the amount of epineurial and interfascicular fibrosis that it was not possible to resect all of the contused segment even at secondary neurorrhaphy. ($\times 22.5$)



FIGURE 264.—Cross section through first part of distal stump of severed median nerve sutured 9 months earlier. An enlarged and edematous proximal stump was sutured to a small, fibrotic, distal segment, and the union was enclosed in tantalum foil. The proximal outgrowth overflowed the anastomotic zone and formed the epineurial neuroma shown here. ($\times 30$)

lesions which had been grafted came to surgery. Specimens of three different types of nerve graft were obtained, as follows: (1) A whole fresh homograft, taken from an amputated limb, which had been used to bridge an 80-mm. deficit in a posterior tibial nerve; (2) a frozen dried homograft taken from the sciatic nerve 12 hours after death and placed in an 85-mm. deficit in a posterior tibial nerve; and (3) the anastomotic site between a cabled sural autograft and the distal stump of a severed radial nerve.

In the last case, 33 mm. of a 75-mm. deficit had been overcome by the usual methods of mobilization and elbow flexion, and four cables of the sural and median sural nerves were used to complete the union. The specimen was removed at a second operation in which the distal anastomosis was freshened. At this time, it was learned by electrical stimulation that nerve fibers had traversed the graft and entered the distal stump. This finding was confirmed by microscopic study, but the graft cables (fig. 270A), as well as the distal nerve segment (fig. 270B), had undergone a marked, diffuse, fibrosing process that seemed sufficient to prevent anything approaching

a normal functional return. In the 4 months following the freshening of the distal anastomosis, nerve fibers had grown approximately 150 mm., as judged by the advance of the Tinel sign. In the 4½-month interval between the placing of the graft and the second operation, nerve fibers had grown through the degenerating graft and as far as the extremely fibrotic distal union, a distance of only 42 mm.

In a series of approximately 20 fresh and frozen dried homografts previously studied at the Walter Reed General Hospital, no evidence of success was obtained beyond the finding of neurotization of the first 10 mm. of most grafts and the complete neurotization of a small 30-mm. frozen dried graft in a median nerve. The fresh homograft and the frozen dried homograft (fig. 271) mentioned above and recovered at Halloran General Hospital showed essentially similar pictures, consisting of the usual signs of tubular disintegration, with dense replacement fibrosis in most of the graft, and clusters of amyelinated nerve fibers penetrating the dense connective tissue of the first centimeter of the graft (color plate 12).

COMMENT

No acute injuries were included in this study of the neuropathologic processes in 228 injuries in which neurorrhaphy was performed. The majority of the 203 patients were seen between the third and sixth months after wounding. The series included the following groups:

1. Patients awaiting definitive care, who had been evacuated from overseas because peripheral nerve centers in the theater had a capacity load.
2. Patients who required reexploration after having had definitive treatment at oversea or Zone of Interior neurosurgical centers.
3. Patients in whom neurorrhaphy had been delayed because of spurious or temporary signs of spontaneous recovery.
4. Patients in whom nerve repair had been delayed for other reasons, such as the presence of residual infection or the necessity for orthopedic surgery.

Exclusive of 13 lesions in essentially fibrous continuity, and 57 suture sites, 103 lesions in neuromatous continuity were resected. These formed the largest group of the series. About half that number of complete severance cases were studied. The resection of 103 neuromas in continuity may be contrasted with the decision, over the same period, to allow 105 unqualified lesions in continuity to continue to recover spontaneously without further intervention other than external neurolysis and an occasional transposition or enclosure in a tantalum sleeve.

A nerve which was the site of stretch palsy, a nerve eroded by an aneurysm, and three nerve grafts of separate types were also studied and reported.

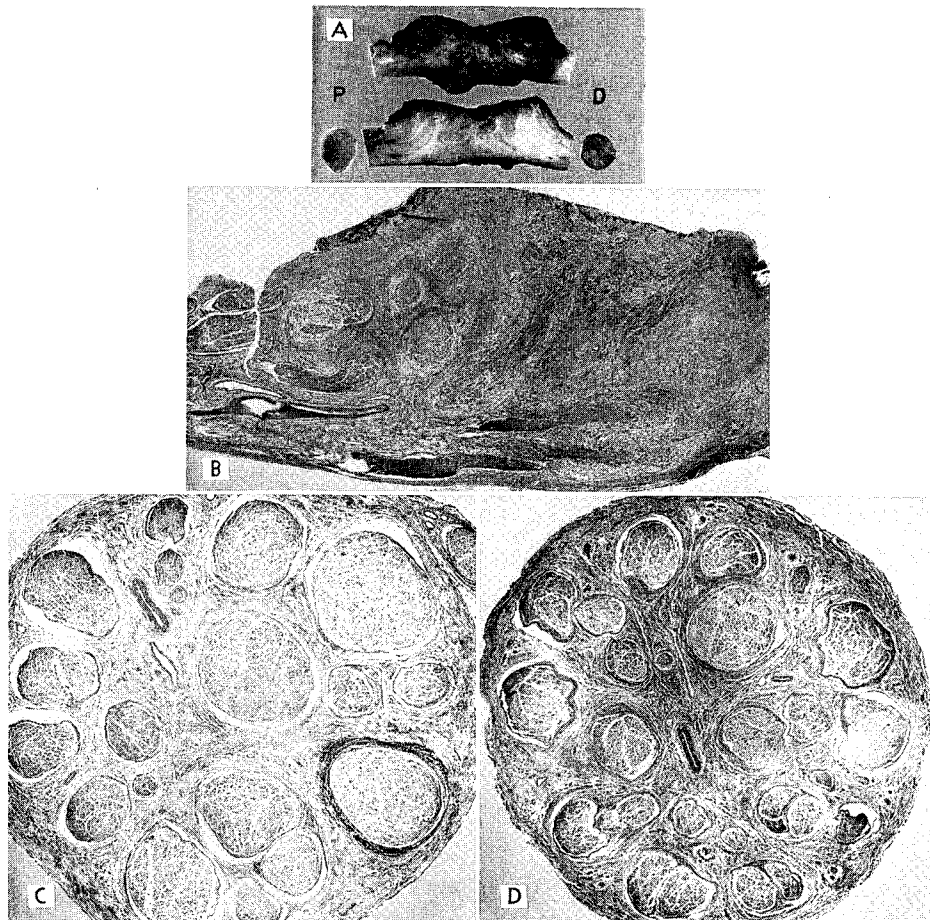
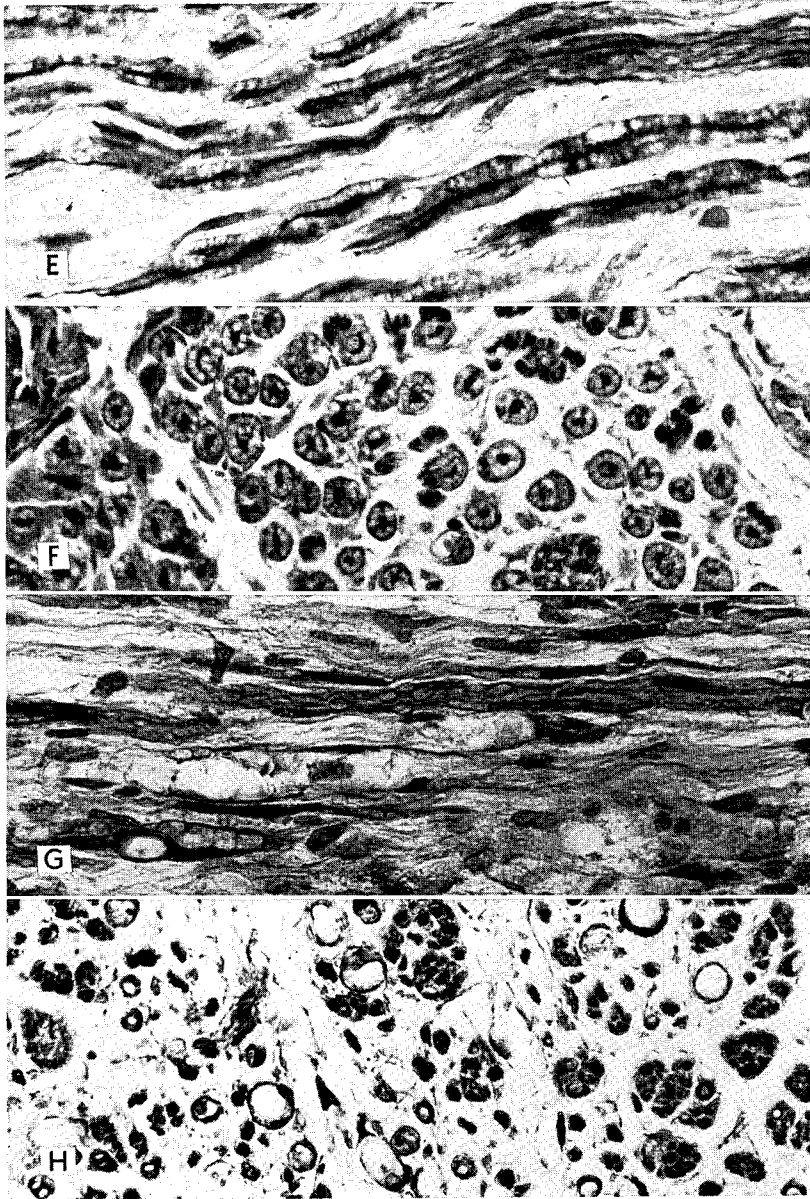

FIGURE 265.—Complete severance of median nerve. A. External view (above) and transverse and median longitudinal sections (below) of median nerve sutured 2 months earlier, at time of injury. (P, proximal; D, distal.) B. Median longitudinal section through proximal neuromatous parts of nerve shown in A. Sutures were found in the region at the extreme right. The surgeon's first trial section is seen on the left. ($\times 6$) C, D. Cross sections through proximal (C) and distal (D) stumps of median nerve shown in A. These sections represent the mirror images of the ends sutured at secondary neurorrhaphy. Slight epineurial and interfascicular fibrosis is present. ($\times 15$) E. Longitudinal section through proximal end of suture site shown in A. Most of the nerve fibers are well myelinated, and clusters of regenerating, amyelinated fibers are also



present. F. Transverse section of same specimen. ($\times 500$) G, H. Longitudinal and transverse sections through distal end of specimen shown in A. Fine, intertwining nerve fibers have regenerated through the suture site and have grown along the vacuolated distal tubules, some of which still contain detritus. ($\times 500$)

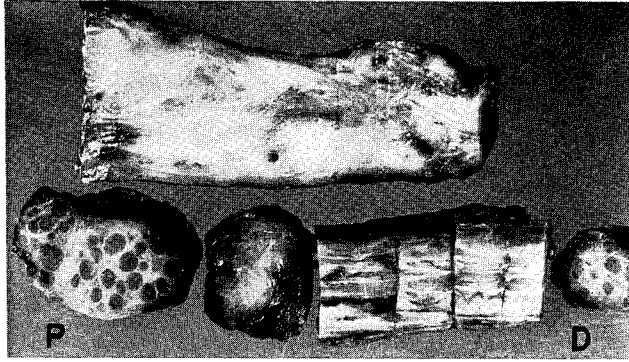

FIGURE 266.—Bulb suture of common peroneal nerve. Upper: fibrotic segment of bulb-sutured common peroneal nerve, proximal to, and at site of, heavy silk sutures. Lower, left to right: proximal cross section, first distal cross section, distal longitudinal section, and last distal cross section. The first distal cross section is completely fibrotic, and the last shows marked fibrosis; only after resecting 4 cm. of it was a regular fascicular pattern attained. ($\times 1.5$)

From direct observation and electrical stimulation of the lesions in situ, from gross and microscopic study of the resected specimens, and from clinical evaluations of some of the cases postoperatively, it was concluded that the main obstacle to good nerve regeneration was fibrosis. This is stated with due respect for the all-important fibrosis of the suture line that must be kept at a minimum and encouraged to be as orderly as possible by very careful surgery.

The main forms of fibrosis to be prevented or overcome were as follows:

1. Fibrous replacement within the tubules undergoing degeneration, whether distal to the zone of severance or retrograde along the proximal stump. This process eventually obliterated most of the cross sectional area available to regenerating nerve fibers, and, as it progressed, it minimized the chances of the regenerating fibers to thicken and myelinate. This endoneurial fibrosis could be obviated by bringing the degenerating distal tubules into contact with the greatly proliferated nerve fibers of the proximal stump as soon as possible after the extent of the lesion had become demarcated (usually about 3 weeks after injury).

2. Scar tissue that formed in the region of nerve severance, contusion, or stretch. This form of fibrosis might be so extensive as to make difficult its complete radication from the suture site, even though resection of several centimeters proximal and distal to the main point of injury were resorted to.

3. Scar tissue of the surrounding bed of a contused or repaired nerve. This tissue might sometimes enclose a nerve within dense, constricting bands and render it functionless, even though no axons were severed. It was usually possible to remove this scar tissue without endangering the nerve, which then could be wrapped in a tantalum sleeve or transposed.

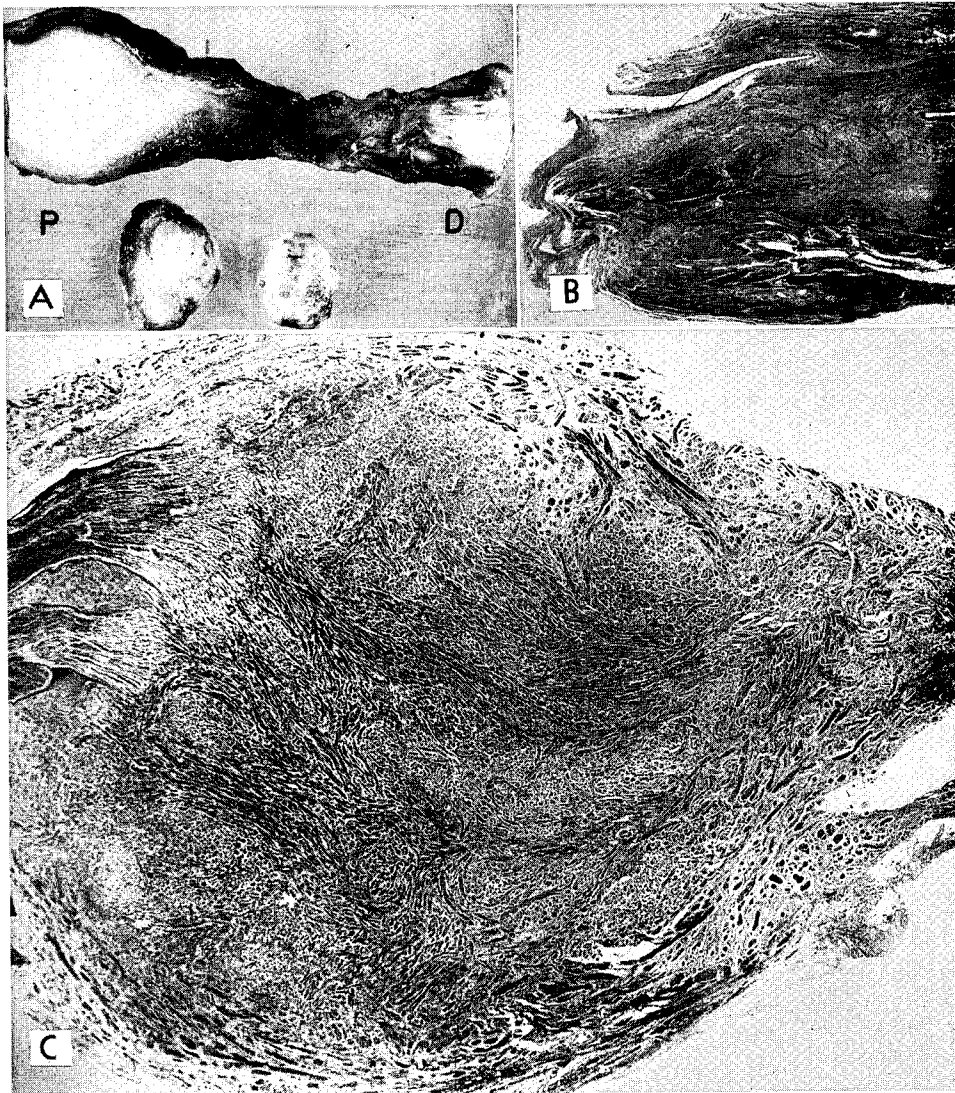

FIGURE 267.—Disruption of radial nerve after suture. A. Median longitudinal and transverse sections of radial nerve which disrupted after suture. The proximal (P) neuroma and distal (D) glioma were joined by a fibrous isthmus. ($\times 1.5$) B. Median longitudinal section through distal stump shown in A. Fragments of a tantalum sleeve used in wrapping the anastomosis were removed from the indented areas at the left. ($\times 9$) C. Median longitudinal section through proximal neuroma shown in A. The neuroma tapers off to the fibrous isthmus distally. In the upper left, a fascicle has transformed into typical neuromatous whorls. Degenerated muscle fibers and adhesions cover the epineurial surface. ($\times 9$)

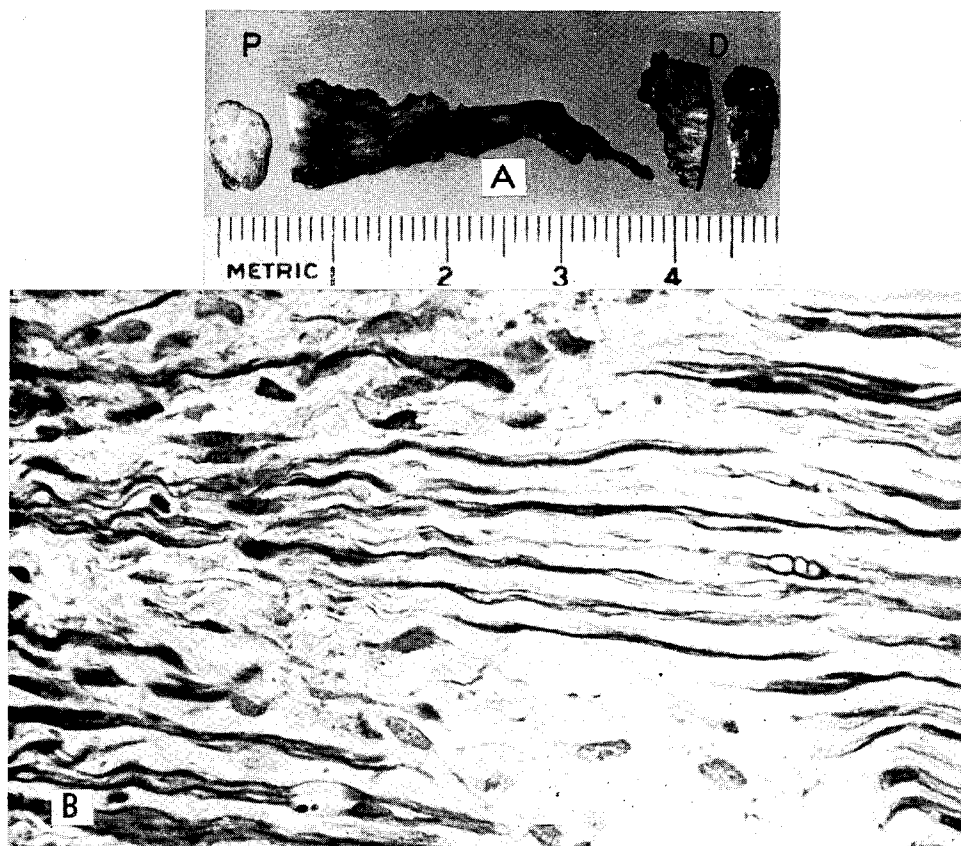

FIGURE 268.—Disruption of common peroneal nerve after suture. A. Transverse median longitudinal sections of proximal (P) and distal (D) stumps of sutured and disrupted common peroneal nerve. The 15-mm. tail on the proximal stump represents the fibrous tissue found joining the stumps. ($\times 15$) B. Longitudinal section through fibrotic fascicle of distal stump shown in A. In 1 month, the fine nerve filaments shown here had penetrated the degenerated Schwann tubules after growing through about 30 mm. of the connecting fibrous tissue. ($\times 600$)

FIGURE 269.—Stretch fibrosis of common peroneal nerve. A. Proximal (P) and distal (D) cross sections and median longitudinal section through common peroneal nerve showing stretch fibrosis. B. Longitudinal section through distal end of specimen shown in A. A few isolated remnants of fascicles are seen among the dense scar tissue and the crisscrossing small regenerating nerve fiber groups. ($\times 9$) C. Longitudinal section through fascicle of nerve shown in A. Some of the nerve fibers that have persisted in the dense collagenous reaction show granular degeneration. ($\times 600$)

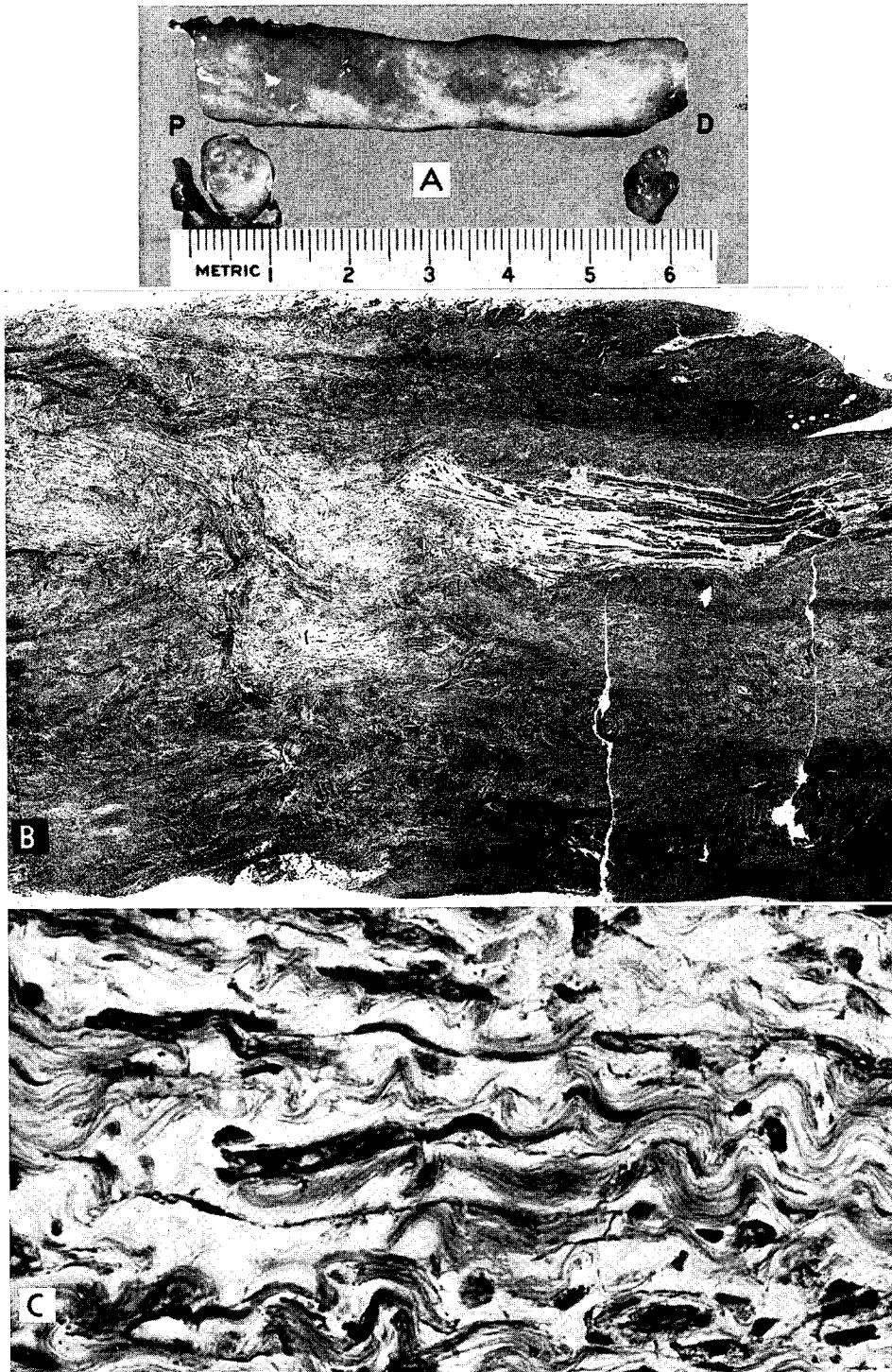

FIGURE 269. (See opposite page for legends.)

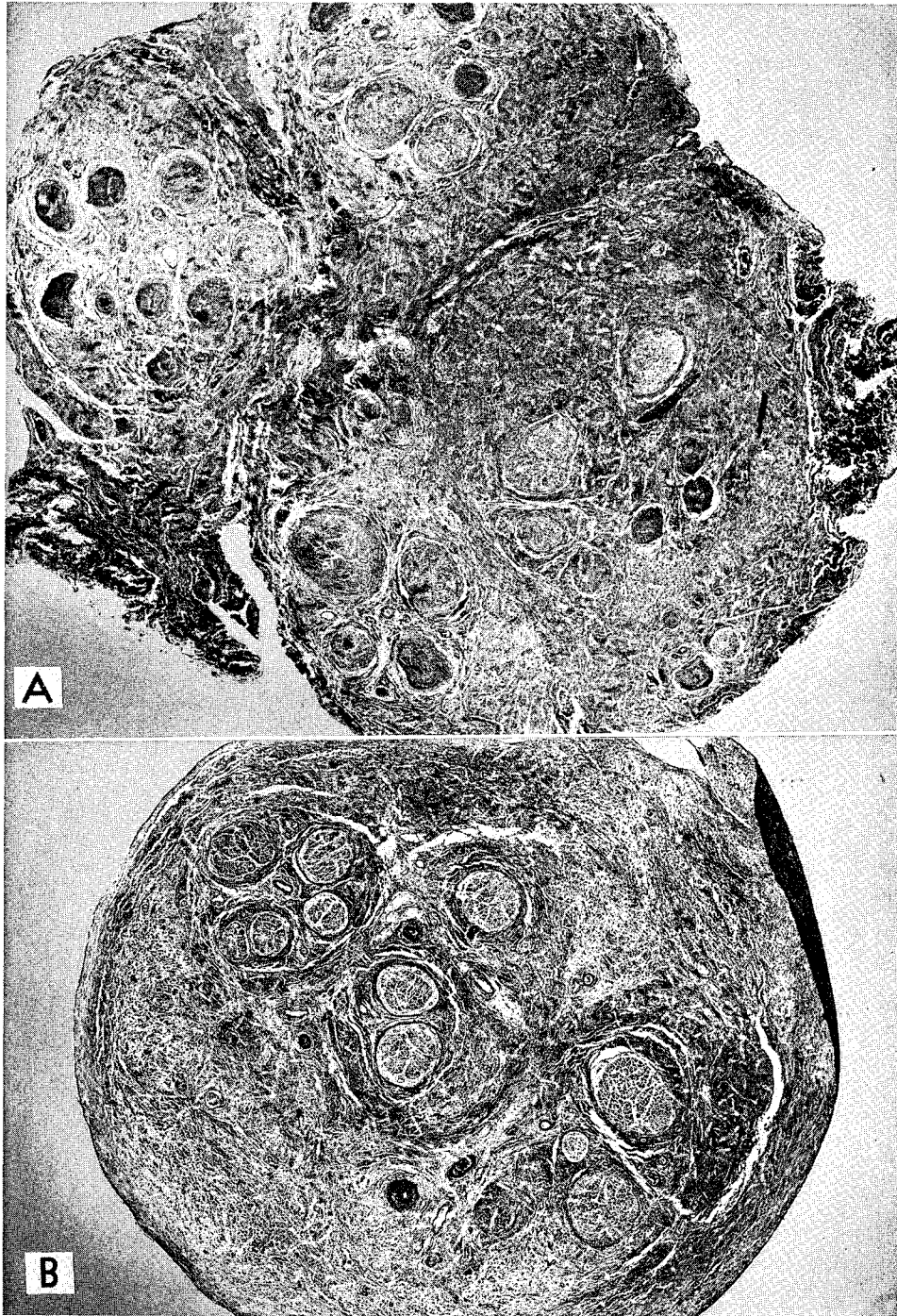

FIGURE 270. (See opposite page for legends.)

During the period of this survey, seven severed nerves presented gaps too extensive to be overcome by the usual methods. Three of these were cutaneous nerves; three were substituted for by tendon transplantation; and one was managed by a sural, cabled autograft through which nerve fibers regenerated.

Nerves repaired in such a manner as to minimize fibrosis regenerate at the rate of approximately 2.5 mm. per day as judged by the Tinel sign and resumption of function in the parts supplied.

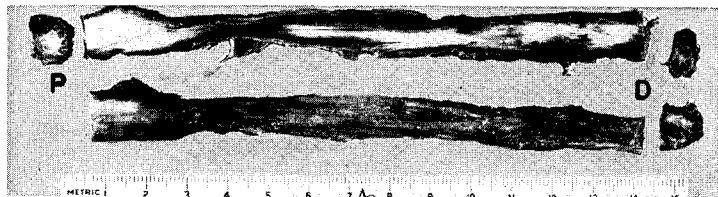

FIGURE 271.—Cabled, frozen dried nerve homograft inserted between proximal and distal stumps of posterior tibial nerve (shown here) 18½ months earlier.

FIGURE 270.—Repair of radial nerve defect by sural autograft cables. A. Cross section through 4 fused sural autograft cables placed in radial nerve defect 4½ months earlier. Note diffuse fibrosis and matting together of the cables by adhesions. Regenerating nerve fibers had grown along some of the degenerated fascicles to the distal nerve stump. (× 20) B. Cross section through distal stump to which autograft shown in A was sutured. Note extreme generalized fibrous and fascicular atrophy. Nerve fibers from the graft had grown into the fascicles and the extrafascicular fibrous areas. (× 20)

CHAPTER XXII

Physical Therapy in the Management of Peripheral Nerve Lesions

William K. Massie, M.D.

At the beginning of World War II, a not inconsiderable number of medical officers, including some neurosurgeons, believed that physical therapy was of little value in many conditions except for its palliative aspects. This attitude did not persist. During the war, both experimental studies and overwhelming clinical evidence showed that the application of this modality to many varieties of war wounds was fully justified from every standpoint. In peripheral nerve injuries, physical therapy came to be regarded as an integral part of the total therapy, and it also came to be an important phase of all plans of rehabilitation.

In all U.S. Army hospitals, physical therapy was conducted under the supervision of the orthopedic sections. This was an essentially correct arrangement. General policies affecting the somatic system could best be prescribed under the direction of orthopedic surgeons. The transfer of patients from one center to another, which was necessary for various reasons, at times seriously interfered with continuity of treatment. Fortunately, uniformity of recordkeeping as well as, to some extent, uniformity of methods in the various hospitals did much to overcome this obstacle.

Physical therapy, as it related to peripheral nerve injuries in World War II, had three aspects; namely, diagnostic, therapeutic, and psychologic. Unless, however, the basic physiologic-pathologic changes produced by injuries of the peripheral nerves were clearly understood, neither logical prescription nor competent management of these injuries was possible, and the best results were not likely to be obtained.

CHANGES IN THE NEUROMUSCULAR SYSTEM PRODUCED BY PERIPHERAL NERVE INJURIES

Muscle changes.—After denervation caused by injury, atrophy of the affected muscles begins promptly and progresses rapidly for 4 to 6 weeks. The rate is then appreciably retarded.¹

Interstitial fibrosis is minimal during the first 3 months after injury. For the next 4 to 12 months, muscle fibers decrease in size, lose definite

¹ Bowden, R. E. M., and Gutmann, E.: Denervation and Re-Innervation of Human Voluntary Muscle. *Brain* 67: 273-313, December 1944.

striation in some portions, and show an increase in interstitial fibrosis, particularly in perivascular areas. Intact nerve end-plates are progressively more difficult to demonstrate. At the end of 3 years, fibrous tissue has almost completely replaced muscle fibers, and such fibers as persist undergo changes generally interpreted as irreversible.

The effects of tension demonstrated by Hipps² in biopsies of muscle from patients with poliomyelitis may be appropriately cited here. Transverse lines of fibrosis, interpreted as healed muscle tears resulting from overstretch, could be seen extending across fasciculi. In other sections, fasciculi, though apparently innervated, were undergoing degeneration because they were embedded in masses of fat which obliterated all muscle tension. These observations were partly substantiated by functional tests on denervated muscle.³

Prolonged rigid immobilization in nerve injuries also played its part in muscle changes in combat casualties. Under these circumstances, muscle changes were often observed in the atrophy associated with fractures. As long as a muscle remained innervated, the process which has been described was largely reversible, and no permanent weakness due to fibrosis and muscle replacement occurred. When, however, denervated muscle was immobilized, the process of fibrous replacement was greatly enhanced.⁴

Joint changes.—The most serious sequelae of immobilization after injury occur in the joints, which may be left irreparably stiff. There is sound evidence that a normal joint, without associated vascular disturbances, may be immobilized for prolonged periods without becoming permanently stiff,⁵ but joints distal to a peripheral nerve lesion cannot be considered normal. They are affected by the peripheral vascular changes common to all such injuries. Periarticular edema, if it is not combated by active muscle contractions, will result in organization of the edema, with resulting permanent disability.

Nerve changes.—The pathologic changes in nerve trunks which occurred after combat-caused injury were of three principal types, depending upon the severity of the causative trauma,⁶ as follows:

1. Contusion or neurapraxia.⁷ This process is a transitory interruption of nerve impulses, the mechanism of which is not completely understood. It closely simulates the paralysis which follows the use of a tourniquet, in

² Hipps, H. E.: The Clinical Significance of Certain Microscopic Changes in Muscles of Anterior Poliomyelitis. *J. Bone & Joint Surg.* 24: 68-80, January 1942.

³ (1) Eisenhower, J., and Key, J. A.: Studies on Muscular Atrophy: A Method in Recording Power in Situ and Observations on Effect of Position of Immobilization on Atrophy of Disuse and Denervation. *Arch. Surg.* 51: 154-163, October 1945. (2) Hipps, H. E.: Muscle Behavior Following Infantile Paralysis. *Am. J. Surg.* 53: 314-318, August 1941. (3) Hines, H. M.: Effects of Immobilization and Activity on Neuromuscular Regeneration. *J.A.M.A.* 120: 515-517, 17 Oct. 1942.

⁴ Huddleston, O. L.: Recent Experimental Studies on the Effects of Immobilization of Denervated Muscle. *South. M.J.* 37: 72-77, February 1944.

⁵ McMurray, T. P.: Uses and Abuses of Splints and Other Instruments in the Treatment of Nerve Lesions. *Brit. J. Phys. Med.* 5: 20-25, February 1942.

⁶ Bunnell, Sterling: *Surgery of the Hand.* Philadelphia: J. B. Lippincott Co., 1944.

⁷ Seddon, H. J.: *Peripheral Nerve Injuries.* Glasgow M.J. 139: 61-75, March 1943.

which there is temporary intermittent thinning of the axis cylinders and loss of myelin.⁸

2. Partial severance or axonotmesis. This process is a rupture of the axis cylinders in which, however, their supporting structure is preserved. Later, the distal segment undergoes degeneration, but regeneration occurs down the original sheaths.⁹

3. Complete severance or neurotmesis. In this process, the supporting structure of the nerve trunk is interrupted, and, as a result, it is practically impossible for any axis cylinder to regenerate down to its original sheath.

In the first and second of the processes just described, regeneration of the damaged nerve is inevitable. In the third, eventual recovery depends, in large part, on early alinement of the nerve tubules. If they are alined promptly, axis cylinder regeneration is possible. If they are not promptly alined, the tubules become fibrosed.¹⁰ Marked alterations occur in the nerve end-plates as time passes, and these changes greatly prolong reinnervation, though regeneration of axis cylinders from proximal segments to end-plates does not appear to be greatly inhibited by the delay. The rate of regeneration differs according to the nerves affected. It occurs most rapidly in the radial, musculocutaneous, and external popliteal nerves, and most slowly in the median and ulnar nerves.¹¹ Reinnervation at the end-plate is profoundly affected by delay, most probably because a gradual fibrosis of the sarcolemma of the muscle fiber presents penetration of axoplasm to the end-plate.¹² The axoplasm is forced to run between muscle fibers and eventually forms incomplete new end-plates. Obviously, muscle changes progress until the fibers actually respond to nerve impulses.

Vascular changes.—Vascular changes resulting from nerve injury are of two types, as follows:

1. Primary changes, which are the result of loss of the sympathetic nerve supply to the area and which are gradually compensated for by overlap from surrounding nerves.

2. Secondary changes, which result from a lack of muscular activity.

DIAGNOSTIC ASPECTS OF PHYSICAL THERAPY

The diagnostic aid afforded by the techniques of physical therapy proved essential in World War II in processing large numbers of patients with peripheral nerve injuries and thus making it possible for them to

⁸ Chamberlain, R. D.: Some Aspects of Physical Therapy in Relation to Peripheral Nerve Injuries. *Arch. Phys. Therapy* 24: 603-609, October 1943.

⁹ Cooksey, F. S.: Co-Ordination of Physical Methods in the Treatment of Peripheral Nerve Injuries. *Brit. J. Phys. Med.* 5: 25-27, February 1942.

¹⁰ Spurling, R. G., and Woodhall, B.: Experiences With Early Nerve Surgery in Peripheral Nerve Injuries. *Ann. Surg.* 123: 731-748, May 1946.

¹¹ Kovacs, R.: Physical Therapy in Peripheral Nerve Injuries. *New York State J. Med.* 43: 1403-1408, 1 Aug. 1943.

¹² Gutmann, E., and Young, J. Z.: Re-Innervation of Muscle After Various Periods of Atrophy. *J. Anat.* 78: 15-43, January 1944.

receive early definitive treatment. Periodic muscle testing provided information essential for management and not obtainable in any other way.

Muscle testing, if it was to be relied upon, had to be carried out thoroughly and precisely. A careless observation or a record completed on assumption could mean the difference between prompt exploration and watchful waiting. Great care also had to be exercised in correctly interpreting the so-called trick or substitution movements. The techniques of muscle testing are described in detail elsewhere.¹³

The basic muscle chart used in neurosurgical centers was used in its original form in some neurosurgical centers. In a number of others, it was revised so that the muscles were listed in the order of origin of their branches from the parent nerve trunk. By the use of these charts, a trained observer could localize a lesion accurately at a mere glance, and, by comparison of the recorded results of the examinations carried out every 10 days, he could ascertain even minimal progress just as quickly.

Electrodiagnosis

Galvanic-faradic testing.—Electrodiagnosis proved of definite value in differentiating neurapraxia from other, more serious lesions if more than 3 weeks had elapsed since wounding. During the first 3 weeks after injury, the degenerative process is not complete (p. 557), and the galvanic-faradic response is not useful.

Physical therapy units sent overseas were equipped with the portable McIntosh machine, on which measurements of current strength were known to be accurate. The current strength required to produce a response was entered on the chart opposite the muscle tested. On successive tests, a decrease in the rheobase or the disappearance of a faradic response which had previously been present was a sufficiently accurate indication of degeneration. These observations were in many instances the deciding factor in bringing patients to exploration during the optimum time for nerve suture. As time passed, the operative findings, which generally confirmed the preoperative observations, made the surgeon more and more confident of the accuracy of the electrodiagnostic method. When nerve trunk destruction was incomplete, however, or when a muscle was doubly innervated, the results were sometimes confusing.

Galvanic-faradic testing continued to be used by the great majority of physical therapy units in the European theater during the war. In the Zone of Interior, other methods of determination came into use. The continued use of this technique, however, was regarded as justified in a communications zone, in which muscle testing had but a single objective, to help the surgeon diagnose a degenerative nerve reaction at the earliest possible

¹³ (1) War Memorandum Series No. 7: Aid to the Investigation of Peripheral Nerve Injuries. British Medical Research Council, reprinted 1945. (2) Spurling, R. G., and Matson, D. D.: Simple Tests of Nerve Trunk Injuries. Bull. U.S. Army M. Dept. No. 75, pp. 71-76, April 1944.

moment. A second reason for continuing to use this technique was that technicians were more familiar with it than with other methods.

Chronaxie determinations.—Strength duration or chronaxie determinations were used to supply information not only about the process of degeneration and the period it covered but also about the beginning of regeneration. The curves for normal muscles were established by Ritchie,¹⁴ and the machine employed was so calibrated that the voltage did not vary with changes in resistance between electrodes. Rectangular waves of 1 millisecond were found to stimulate a normal muscle at a voltage considerably lower than is required by a denervated muscle. This type of stimulus approached normal some weeks before other signs of regeneration were evident, and these findings were interpreted to mean that the axoplasm had joined the end-plate but was not yet able to conduct an impulse throughout its whole length.

Galvanic-tetanus ratio.—The progressive current measurement advocated by Pollock and his associates,¹⁵ which was of prognostic value in determining the presence of nerve regeneration, was also found to be quite accurate in the determination of the period of degeneration. Its action depends upon the phenomenon that a denervated muscle will respond to a much lower current than a normal muscle if the current is allowed to increase very slowly over a given period of time. The normal muscle seems to accommodate to the gradual change. The denervated muscle apparently cannot. The gradient increase of current required to produce a response during the period of degeneration (the first 14 days after wounding) must be steeper than is required during the period of regeneration. When regeneration begins, the increase suddenly (within a period of 2 or 3 days) jumps to a much steeper gradient than at any other time. The gradient then gradually returns to normal long after muscle function has returned.

The galvanic-tetanus ratio is the ratio between the minimal current required to produce tetanus divided by the minimal current required to produce a single contraction (rheobase). The usefulness of the observation is based on the fact that, in denervated muscle, the current required to cause tetanus very closely approaches the rheobase, while in a normal muscle the ratio is approximately 6 : 1. The increased sensitivity is considered by the proponents of the therapy of chemical transmission of nerve impulses to indicate the normal sensitivity of the cells without the constant inhibition provided by intact nerves.¹⁶

¹⁴ Ritchie, A. E.: Electrical Diagnosis of Peripheral Nerve Injury. *Brain* 67: 314-330, December 1944.

¹⁵ (1) Pollock, L. J., Golseth, J. G., Arieff, A. J., Sherman, I. C., Schiller, M. A., and Tigay, E. L.: Electrodiagnosis by Means of Progressive Currents of Long Duration: Studies on Cats With Experimentally Produced Section of the Sciatic Nerves. *Arch. Neurol. & Psychiat.* 51: 147-154, February 1944. (2) Pollock, L. J., Golseth, J. G., Arieff, A. J., and Mayfield, F.: Electrodiagnosis by Means of Progressive Currents of Long Duration; Studies on Peripheral Nerve Injuries in Man. *Surg. Gynec. & Obst.* 81: 192-200, August 1945.

¹⁶ Loewi, O.: Aspects of the Transmission of the Nervous Impulse. *J. Mount Sinai Hosp.* 12: 851-865, September-October 1945.

As regeneration occurs, the ratio becomes higher than normal, and tetanus eventually cannot be produced because the current required to demonstrate it is too high to be tolerated without anesthesia.

The galvanic-tetanus ratio, before the war ended, had largely replaced the galvanic-faradic test in Zone of Interior hospitals because it was found to be more accurate as well as productive of more information. Another advantage was that it did not require the intricate equipment needed for the progressive current or strength duration current tests.¹⁷

Dermometer.—Although a great deal was written about the use of the dermatometer toward the end of the war,¹⁸ it was not found to be as accurate a diagnostic method as the other techniques described, because of the uncertainty of nerve overlap. This machine, however, is quite simple to operate, and it was found useful in some oversea units in which large numbers of patients had to be tested in a short time. Its action depends upon the fact that skin resistance is greatly increased when normally acting sweat glands are sparse or absent and, in peripheral nerve lesions, when sympathetic fibers to the area are also sectioned.

TECHNIQUES OF PHYSICAL THERAPY

When physical therapy was employed as a modality of treatment, the methods used depended upon the stage of the lesion.

First Stage

The first stage of management of a nerve injury covered the period from wounding to wound healing and the control of edema resulting from the vasomotor imbalance caused by autonomic nerve interruption plus muscular inactivity. During this period, the wound received the principal attention. As long as it remained open, adjunct therapy was greatly inhibited or could not be employed at all.

It was generally agreed that 90 percent or more of all wounds in which peripheral nerves were involved could be closed by delayed primary wound closure within 14 days after wounding; actually, the timelag was usually considerably less.

Early motion.—Motion of joints distal to the injury necessarily depended upon the location of the wound, but, in general, the principles of early active motion, elevation of the distal part, and provision of continued pressure by means of elastic dressings proved the best treatment for both healing of the wounded area and maintenance of normal joint motion. A

¹⁷ (1) Dillin, E. L.: Physical Therapy in the Treatment of Neurosurgical Conditions. *Physiotherapy Rev.* 26: 309-315, November-December 1946. (2) Pollock, L. J., Golseth, J. G., and Arieff, A. J.: Galvanic Tetanus and Galvanic Tetanus Ratio in Electrodiagnosis of Peripheral Nerve Lesions. *Surg. Gynec. & Obst.* 81: 660-666, December 1945.

¹⁸ (1) Hyman, I., and Beswick, W. F.: Measurement of Skin Resistance in Peripheral Nerve Injuries. *War Med.* 8: 258-260, October 1945. (2) Jasper, H., and Robb, P.: Studies of Electrical Skin Resistance in Peripheral Nerve Lesions. *J. Neurosurg.* 2: 261-268, July 1945. (3) Pollock, L. J.: Diagnosis of Peripheral Nerve Lesions. *Clinics* 4: 240-262, August 1945.

joint uselessly immobilized or allowed to become immobile because of the collection of edema in the extremity distal to the wound added a new and preventable disability, the correction of which often proved more difficult than the management of the nerve injury itself. Unfortunately, circumstances beyond the control of the neurosurgeon had often produced just such changes before the patient reached an installation in which unified medical management was possible.

Splinting.—During the first stage of a peripheral nerve injury, splinting—unless a fracture was present—was used for a single purpose, to maintain the part in a comfortable, neutral position which would prevent the overpull of unopposed normal (uninjured) muscles.

The part was splinted immediately after delayed primary wound closure, to prevent stress on the recently sutured wound. The splint used at this time was usually of plaster and, since continuous immobilization might be necessary for a short period, was not of the removable type used later. Joints whose motion would not seriously interfere with wound healing or cause the patient constant discomfort were left free to move, though positions of contracture had to be prevented.

If a fracture was present in association with the nerve injury, a more stable type of cast was, of course, necessary.

Galvanic stimulation.—It was not usually feasible to begin galvanic stimulation before delayed primary wound closure. When it was feasible and could be carried out without causing the patient undue discomfort, it was employed daily, with a careful sterile technique, even in the presence of open wounds. This was sound practice, since maximum atrophy of muscles, as already pointed out, occurs within the first 30 days after wounding. This practice was useful in cases in which nerve injuries were complicated by fractures; these patients received maximum benefits from such pseudoactive exercise.

Casualties whose peripheral circulation was extremely poor and who resisted ordinary means of treatment were sometimes greatly benefited by repeated sympathetic blocks with procaine hydrochloride (Novocain).

Exercises.—About three-quarters of all peripheral nerve injuries occurred in the upper extremity,¹⁹ and the majority of these patients could be ambulatory. This group therefore participated in rehabilitation classes, conducted under the supervision of sergeants in the physical therapy section, almost from the beginning of their hospitalization.

Bed patients were segregated, so that they could be given group exercises. A bulletin, with diagrams, prepared in the European theater and distributed to each patient, described and illustrated the simple but comprehensive exercises which could be carried out in the prone and supine positions.²⁰

¹⁹ Spurling, R. G.: Early Treatment of Combined Bone and Nerve Lesions. Bull. U.S. Army M. Dept. 4: 444-446, October 1945.

²⁰ Taylor, G. M., McFarland, J. W., and Bond, A.: Exercises for the Convalescent Bed Patient. Arch. Phys. Med. 27: 82-89, February 1946.

Associated fractures.—In a series of 621 nerve injuries studied at the neurosurgical center at Halloran General Hospital, Staten Island, N.Y., in 1946, fractures were also present in 21.7 percent.²¹ The percentage is typical. The objective of management in these cases of bone-nerve injury was essentially the same as the objective in cases without associated fractures. The treatment of the nerve injury was the principal concern, and physical therapy played an even greater role than in uncomplicated cases because the reaction to injury with associated edema was much more severe than in uncomplicated cases.

When skeletal traction was employed in combined bone-nerve cases, it was so applied that muscle points could be reached through the bandages and stimulated by portable machines brought to the bedside. When cast fixation was sufficient, the motor points were accessible through appropriately placed windows. In a small number of cases of combined bone-nerve injury, such as injuries of both bones of the forearm associated with radial nerve lesions, immobilization was provided by special methods. External skeletal splints of the Roger Anderson type, for instance, or intramedullary pins were used for the sole purpose of making the extremity available for muscle stimulation.

Massive soft-tissue losses.—In the cases of nerve injuries reported from the neurosurgical center at Halloran General Hospital, massive soft-tissue losses occurred in only 1.1 percent. The small percentage was fortunate, for this complication was far more difficult to manage, from the standpoint of physical therapy, than associated fractures. Primary or delayed flaps were almost always necessary for wound closure, and their chances of survival were not enhanced by the motion incident to muscle stimulation. Even in these cases, however, elastic dressings were used, and flaps were designed with subsequent muscle stimulation in mind.

Second Stage

Heat and massage.—The second stage of management of nerve injuries from the standpoint of physical therapy began with the completion of wound healing and continued until the reinnervation of the end-plate and the first return of voluntary motion. During this period, for the first time, heat and massage were of practical value. The whirlpool bath was particularly useful if it was not contraindicated by associated fractures or for other reasons.²² Experimental evidence suggested that it played no part in decreasing the rate of muscle atrophy, but it seemed to allay the discomfort of galvanic stimulation and encourage active movements of all points.²³ In addition, it was of potent psychologic value.

²¹ Woodhall, B., and Lyons, W. R.: *Peripheral Nerve Injuries. I. The Results of "Early" Nerve Suture: A Preliminary Report.* *Surgery* 19: 757-789, June 1946.

²² See footnote 3(3), p. 558.

²³ Mennell, J.: *Massage, Movements and Exercises in the Treatment of Nerve Suture and Repair.* *Brit. J. Phys. Med.* 5: 40-47, March 1942.

Galvanic stimulation.—During the second stage of management, galvanic stimulation played a major role if it was administered regularly, with current sufficient to elicit strong contractions, and systematically distributed to each denervated muscle. Experimentally, galvanic stimulation begun soon after denervation neither produced hypertrophy nor maintained the normal size of the muscle fibers, but it unquestionably decreased the rate of atrophy.²⁴

There were certain prerequisites for preventing atrophy, as follows:

1. Treatment had to be begun early, at the most within a month of injury.

2. Treatment had to be continued until the return of voluntary contractions.

3. Current strength had to be accurate. It was applied either as separate stimuli, gradually increased to 30 per minute for 3 minutes for each muscle, or in equivalent sinusoidal current.²⁵

When muscles were treated daily according to these criteria, a clear-cut decrease in interfascicular adhesions was demonstrable histologically.²⁶ Clinically, patients who were similarly treated almost invariably presented pliable distal joints and a circulation approaching normal. It was regarded as possible, at least by some observers, that untreated muscle, if not denervated for longer than 18 months, might eventually attain a strength equal to that of treated muscle after reinnervation, though the rate of increase would admittedly be slower.²⁷

The maintenance of normal joint action in itself justified prolonged electrical treatment during the second phase of the nerve injury. Joint mobility cannot be obtained by passive motion. This form of therapy, in fact, often leads to stiffness of the joint, since there is a great compulsion to force it slightly beyond its free range of motion and thus initiate adhesions. Active motion, on the other hand, stimulates the peripheral circulation; reduces local tissue edema, which is the precursor of adhesions; and carries the joint through its full range of motion.²⁸ The possibility that strong contractions might cause stretch tears was not overlooked when electrical treatment was employed in neurosurgical centers. It was, in fact, a strong argument for delegating this work only to experienced personnel who could accurately evaluate early muscle fatigue.

Splinting.—Splinting in the second stage of management of nerve injuries was used to counteract two forces, as follows: (1) That of the normally contracting antagonistic group, and (2) the effect of gravity. It was there-

²⁴ Jackson, E. C. S., and Seddon, H. J.: Influence of Galvanic Stimulation on Muscle Atrophy Resulting From Denervation. *Brit. M.J.* 2: 485-486, 13 Oct. 1945.

²⁵ Grodins, F. S., Osborne, S. L., Johnson, F. R., Arana, S., and Ivy, A. C.: Effect of Appropriate Electrical Stimulation on Atrophy of Denervated Skeletal Muscle in the Rat. *Am. J. Physiol.* 142: 222-230, September 1944.

²⁶ Jackson, E. C. S., Bowden, R. E. M., and Seddon, H. J.: Galvanic Stimulation of Denervated Muscle. *Brit. M.J.* 1: 65-66, 12 Jan. 1946.

²⁷ Gutmann, E., and Guttman, L.: The Effect of Galvanic Exercise on Denervated and Re-Innervated Muscles in the Rabbit. *J. Neurol. Neurosurg. & Psychiat.* 7: 7-17, January-April 1944.

²⁸ Watson Jones, R.: Adhesions of Joints and Injury. *Brit. M.J.* 1: 925-929, 9 May 1936.

fore more effective in instances of extensor muscle paralysis, in which both these factors operate, than in the flexor paralysis.

The optimum position for muscle recovery after denervation was a disputed question during the war, as it had been for years before. Experimental evidence could be cited to support the idea that the risk of overstretching by opposing muscles had been greatly exaggerated as a detrimental factor²⁹ and that holding the muscle in complete relaxation was not an innocuous procedure.³⁰ There was much to prove the contention that the momentary overstretching which might be required of denervated muscles when normal muscles were allowed to contract forcefully was less harmful than that of overzealous splinting, which kept joints in fixed positions and reduced active motion and the consequent increase in circulation.

On the basis of this reasoning, splinting was applied with the following principles in mind:

1. Maintenance of both joints and muscles at either extreme is harmful.
2. Complete immobility in any position is to be avoided over long periods of time.
3. Active motion should be encouraged, while, at the same time, denervated elements must be protected from the constant overpull of both gravity and opposing normal muscles.
4. Whatever method of splinting is selected, it must be so applied as not to embarrass further a circulation which is far from normal.

With these criteria in mind, an operator of normal ingenuity could devise an appropriate splint for any part. A useful rule of thumb was to reproduce the position assumed by the extremity when the denervated muscles were moderately (not forcibly) relaxed and to endeavor to maintain this position by mild elastic action; the spring pickup was used for paralysis of the common peroneal nerve, and the various elastic splints devised by Bunnell and others³¹ were used for the hand and the wrist.

Immediately after nerve suture in which gaps in the trunk were overcome by appropriate positions of adjoining joints to permit increased length, plaster splints were applied and were maintained for from 2 to 3 weeks. During the next 3 weeks, the joint was extended daily for an additional one-half inch daily, which permitted active and passive motion within the range permitted by the splint.³²

Occupational therapy and work.—A patient might remain in the second stage of nerve management for periods ranging from 12 to 18 months. During this time, when he was not actually receiving physical therapy, he

²⁹ See footnote 3(1), p. 558.

³⁰ (1) See footnotes 2 and 3(1). (2) Heyman, C. H.: When Should the Poliomyelitis Patient be Splinted? *Ohio State M.J.* 41: 432-436, May 1945.

³¹ (1) See footnote 6, p. 558. (2) Highet, W. B.: Splintage of Peripheral Nerve Injuries. *Lancet* 1: 555-558, 9 May 1942. (3) Wilson, H. C.: Physical Therapy in a Plastic Surgery Unit. *Physiotherapy Rev.* 25: 3-21, January-February 1945. (4) Elastic Splint for Foot Drop. *Bull. U.S. Army M. Dept.* 4: 374, October 1945.

³² See footnote 10, p. 559.

was being guided in preparation for work of his own choice. If his progress was satisfactory, he might even assume a full-time job.

The more severely wounded, of course, could undertake only diversional occupational therapy in addition to physical treatment.

At this phase of management, the psychologic aspects of treatment were most important (p. 568). As the patient lost the protective environment of many companions affected as he was and began to compete on equal terms with normal individuals, he often required advice.

Periodic testing.—During the second stage of nerve injuries, periodic electrodiagnostic tests were carried out to determine as soon as possible the progress of regeneration. These tests were of value to the surgeon, who had to consider exploration if progress was not noted, and were also a morale-building factor to the patient when progress was encouraging.

Third Stage

Management in the third stage of a nerve injury was a gradual extension of the measures used in the latter part of the second stage except that, by this time, partial muscle reinnervation had occurred, and attention was concentrated on active stimulation of the involved fibers. As a guide to therapy, it was found useful to apply the criteria suggested by Dillin,³³ as follows:

1. When a muscle can develop less than 10 percent of normal tension, passive motion is necessary, with the patient attempting to contract it.
2. When the muscle can develop from 10 to 50 percent of normal tension, the patient can be assisted through a full range of motion.
3. When muscle strength is over 50 percent, resisted motion is necessary for full development of its power.

Muscles had to be made to work against resistance in order to develop strength. More could be accomplished in a few minutes of resistance exercises than in hours of free-swinging exercises, as suggested by the proponents of the Danish school of gymnastics. In fact, clinical differences were apparent in the muscles treated by these different methods. A system of exercises designed to furnish constant resistance through muscle excursion was far more efficient than a system designed to furnish gradually increasing resistance. At first, these exercises could not be left to the patient's discretion, because fatigue, which it was necessary to prevent, was not easily perceived. A swimming pool proved the best single adjunct to treatment at this phase of recovery.

Galvanic stimulation was continued until voluntary muscle twitches were observed. At this time, if elastic splints had been required, they were gradually abandoned, since the patient was able to maintain the part in neutral position, without support.

³³ See footnote 17(1), p. 562.

Most patients, as the result of occupational therapy during the second stage, were now able to pursue some occupation, either full time or part time. Their progress was followed periodically with repeated muscle tests until maximum recovery had been attained. By this time, they had learned to substitute the actions of some muscles which had recovered rapidly for the actions of muscles which had recovered more slowly. This was not desirable, though it could not be entirely prevented. When, however, a substitute motion was depriving of adequate exercise a muscle in which signs of reinnervation were evident, the patient had to be guided to use the reinnervated muscles. Once it was evident that maximum regeneration had occurred, all possible substitutions were encouraged. Only when this possibility had been exhausted was tendon transplantation or other reconstructive measure considered.

PSYCHOLOGIC ASPECTS OF PHYSICAL THERAPY

The psychologic aspects of physical therapy were important in every phase of management, including the diagnostic phase. Casualties with peripheral nerve injuries of the upper extremities uncomplicated by other injuries either were ambulatory when they were received in neurosurgical centers both overseas and in the Zone of Interior, or they rapidly became ambulatory. It was explained to them immediately that, while rehabilitation of the injured extremity was possible, it would require a prolonged effort, in which they themselves must participate most earnestly.

The concentration of patients with peripheral nerve injuries in neurosurgical centers played an important part in the psychologic benefits of physical therapy. When the single patient associated with so many others in the same predicament as he was, or even in worse predicament, his individual problem was comparably reduced. The daily progress of other patients, both those with more serious injuries and those in more advanced stages of recovery, was always encouraging.

Trained enlisted personnel could be assigned the full-time duty of keeping the patient with a peripheral nerve injury constantly occupied with medically outlined and supervised activity. The responsibility for recovery, however, as was made clear to the patient, rested upon him and not upon the physical therapist. Competitive activity was encouraged and was made as attractive as possible, but the individual patient clearly understood that, in the last analysis, he was the one who determined just how much benefit he would derive from the therapist's efforts.

CHAPTER XXIII

Orthopedic Techniques for Use in Irreparable Nerve Injuries

T. Campbell Thompson, M.D.

GENERAL CONSIDERATIONS

During World War II, a number of casualties were seen at all neuro-surgical centers who had sustained irreparable nerve damage associated with loss of sensation and musclepower. As a rule, the injury which had caused the nerve lesion had also caused extensive damage to the bones, muscles, blood vessels, and skin of the affected extremity. The loss of sensation and the muscular paralysis caused by the nerve injury was sometimes of less importance in the patient's total disability than the damage to other soft tissues or to bone.

From the time such an injury occurred, it had to be borne in mind that the retention of function in the entire extremity was the objective of treatment and was much more important than the restoration of power in a certain group of muscles or of sensation in a certain area of skin. The viewpoint of the orthopedic surgeon in such cases was completely realistic, which means that it was a combination of pessimism and optimism. He realized that a soldier who was crippled to such a degree could practically never be completely restored functionally, but he also comprehended that almost all of these patients could be improved and that any treatment which offered a reasonable chance of improvement should be carefully considered and undertaken.

In the management of irreparable nerve injuries, certain practical considerations had to be borne in mind, as follows:

1. In the upper extremity, loss of sensation in the median nerve constitutes a major disability and is just as great a handicap as is loss of power in the muscles supplied by this nerve. In lesions of other peripheral nerves, however, the patient can soon learn to disregard numbness and often forgets it entirely.

2. Absence of sensation seldom produces serious trophic changes. Even when the weight-bearing area of the foot is completely without sensation, the patient seldom experiences difficulties unless there is an associated de-

formity, such as equinovarus, which causes the body weight to be borne upon one small area instead of upon the entire plantar surface. After complete sciatic paralysis, one might have expected to find ulcers on the sole of the foot or a Charcot joint, but they were seldom observed.

3. In the lower extremity, difficulties due to malalignment were probably more important to the patient than those due to loss of sensation or musclepower. This is because proper alinement of the various weight-bearing segments of the lower extremities is absolutely essential for both standing and walking. In the attempt to restore normal stance and gait, therefore, in a patient with a severe injury of the lower extremity, correction of bony deformity and of soft-part contracture always took precedence over nerve repair or muscle transplantation.

4. In the upper extremity, mobility and musclepower are more important than alinement, though, even here, the usefulness of the hand depends to a great degree upon the position of the shoulder, elbow, and wrist. A normal hand with the wrist fixed in flexion or the forearm completely supinated was much less useful to the battle casualty than a partially stiff hand in good position.

Every battle casualty presented a specific problem and often several problems. The final selection of the procedure to be used in any single case was made only when the surgeon had convinced himself that the procedure or combination of procedures which he proposed to use would more nearly restore normal function than any other procedure or combination of procedures. The occupation of the patient as well as his physical and emotional makeup were also taken into consideration when the decision was made.

Whatever the procedure selected, the following general principles were observed:

1. No transplanted muscle can be expected to overcome a fixed deformity.
2. The production of a deformity in an effort to restore function in muscles supplied by a paralyzed nerve is almost never justified. This principle is particularly applicable to injuries of the lower extremity.

3. In the treatment of fractures, the prolonged immobilization required to ensure solid bony union promotes fibrosis in the muscles, stiffness in the joints, and atrophy in the bones. These changes occur even though weight bearing in plaster is permitted. Prolonged immobilization to support paralyzed muscles while regeneration after nerve repair is awaited also promotes fibrosis, not only in the paralyzed muscles but in normal structures as well. If the chances of success from nerve suture or nerve graft are not good, prolonged splinting of any part, especially in a poor functional position, cannot be justified. Again it must be borne in mind that the function of the extremity as a whole is more important than the partial restoration of power in any group of paralyzed muscles.

OPERATIONS ON THE UPPER EXTREMITY¹

In irreparable nerve injuries of the upper extremity, the operative procedures employed were designed to restore the balance of power between antagonistic muscles. These procedures not only reduced the tendency toward deformity but also produced marked improvement in coordinated muscular activity. They could not be expected to correct deformities which already existed or to restore completely normal function.

Fusion Operations

If paralysis was extensive, fusing operations produced more complete and more permanent correction of deformity than operations on soft tissue and also made additional active muscles available for transplantation to take the place of the paralyzed muscles. This was especially true in the hand and wrist. When any two of the three major nerves in the upper extremity were permanently paralyzed, wrist fusion was usually considered indicated. This operation, in addition to improving the appearance of the hand, fixed the wrist in a good functional position and made available for use as motors of the fingers whatever wrist flexors or extensors were still functioning. Arthrodesis of the elbow or shoulder could be performed if the paralysis about either of these joints was of such magnitude that the joint could not be maintained in a good functional position.

A claw-hand deformity caused by section of the median and ulnar nerves at the wrist could be overcome quite effectively by fusion of the interphalangeal joints of one of the fingers. The long flexor muscles then could flex the entire finger at the metacarpophalangeal joint. Anatomic correction of the hyperextension deformity at one metacarpophalangeal joint produced similar improvement in the other fingers, and the entire claw-hand deformity was thus overcome to a remarkable degree.

Correction of the position of the thumb with fixation of the first metacarpal bone to the second by means of a bone graft was probably the best method of restoring opposition of the thumb when the median nerve had been destroyed high in the forearm or above the elbow.

Transplantation Operations

After paralysis of a single muscle or group of muscles in the upper extremity, transplantation of an active muscle often produced remarkable improvement in function.² In order to restore active abduction of the shoulder after deltoid paralysis, the short head of the biceps and the long

¹ Attention is called to the many ingenious operations for repair of injured hands described in the volume in this series devoted to hand surgery (Medical Department, United States Army. *Surgery in World War II. Hand Surgery.* Washington: U.S. Government Printing Office, 1955).

² (1) Ober, F. R., and Barr, J. S.: Brachioradialis Muscle Transposition for Triceps Weakness. *Surg. Gynec. & Obst.* 67: 105-107, July 1938. (2) Ober, F. R.: Transplantaciones de tendones en las extremidades superiores en la poliomielitis. *Cir. Ortop. y traumatol.* 3: 7-23, January-March 1935.

head of the triceps could be transplanted to the acromion.³ Another procedure employed was the Mayer operation,⁴ in which the trapezius is extended downward by means of a piece of fascia lata, thus permitting active abduction of the humerus by this muscle.

Operations for Axillary Nerve Paralysis

In pure axillary nerve paralysis, the remaining active muscles of the shoulder take over the function of the deltoid very well, and operative measures were therefore seldom necessary. When there was extensive paralysis about the shoulder joint, arthrodesis of the shoulder was usually the operation of choice.

Complete loss of flexor power at the elbow was seldom seen because the various muscles which produce flexion of the elbow are supplied by four different nerves. When surgery was necessary, remarkable improvement could be secured by Steindler's operation of transplanting the origins of the flexors of the wrist and fingers upward on the humerus (figs. 272 and 273).

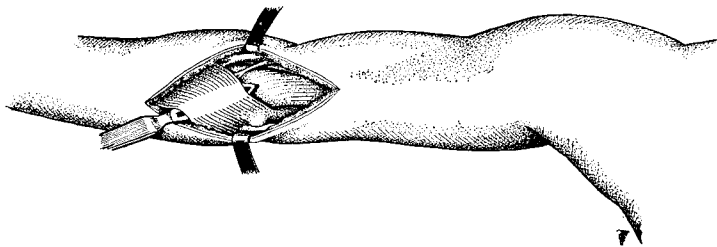

FIGURE 272.—Steindler technique of transplantation of flexor muscles at elbow. The common origin of the flexor muscles from the internal epicondyle is freed and transplanted upward on the humerus to restore active flexion of the elbow.

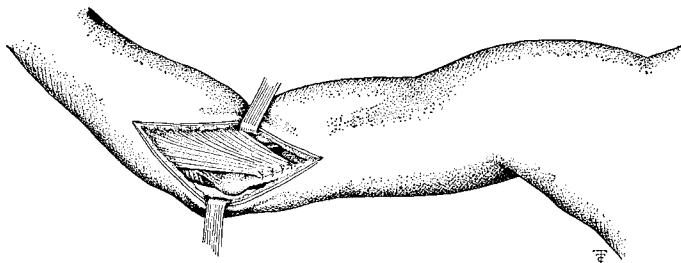

FIGURE 273.—Steindler technique of transplantation of flexor muscles. After the flexor muscles of the wrist and fingers have been transplanted proximally on the humerus, they act as strong flexors of the elbow as well as flexors of the wrist and fingers.

³ Ober, F. R.: An Operation to Relieve Paralysis of the Deltoid Muscle, *J.A.M.A.* 99: 2182, 24 Dec. 1932.

⁴ Mayer, L.: Transplantation of the Trapezius for Paralysis of the Abductors of the Arm. *J. Bone & Joint Surg.* 9: 412-420, July 1927.

Even when the elbow joint could be flexed against gravity without surgery, this procedure was often regarded as justified, to increase the power of flexion.⁵ It was in the forearm and hand, however, that muscle transplantation produced the most gratifying results.

Operations for Radial Nerve Paralysis

Because of the winding course of the radial nerve around the shaft of the humerus and the exposed position of the dorsal interosseous branch on the outer aspect of the elbow, many injuries which caused a fracture of the shaft of the humerus or a fracture of the elbow joint also caused serious and often irreparable damage to this nerve. The sensory loss was of no importance. The loss of extensor power in the fingers and thumb if the lesion was below the elbow, or the complete wristdrop which could result from injuries above the elbow, often produced most unsightly and crippling deformities. As the nerve supply to the extensor carpi radialis longus comes off well above the elbow, this muscle was usually still active when the injury was confined to the dorsal interosseous branch. When the injury was to the radial nerve in the upper arm, wristdrop was complete.

The loss of power to fix the wrist and extend the fingers rendered the hand almost useless, and the wrist had to be firmly fixed in dorsiflexion if the flexor muscles of the fingers and the intrinsic muscles of the hand were again to perform their many and finely controlled movements.

The prognosis for recovery of the radial nerve after injury was fairly good, but the time required for regaining motor function was always long, and recovery was often incomplete. In injuries near the elbow associated with extensive scarring about the head of the radius, there was often loss of considerable substance in the dorsal interosseous branch, and recovery of active power in the extensors of the fingers and thumb therefore seldom occurred.

Transplantation operations.—Extension of the fingers, thumb, and wrist does not need to be as accurately controlled as do the motions of flexion and opposition. This is fortunate. For this reason, muscle transplantation for restoration of motor function after irreparable damage to the radial nerve was almost uniformly successful.

Some procedure of this kind was applied early in all instances of gross loss of substance in the radial nerve if it was thought that recovery after nerve suture or nerve grafting would be uncertain or was likely to be long delayed. An injury involving the dorsal interosseous branch of the nerve could seldom be repaired unless it was only a simple laceration which was seen shortly after wounding. The satisfactory results obtained from tendon transplantation encouraged the performance of this operation without delay

⁵ Steindler, Arthur: Muscle and Tendon Transplantation at the Elbow. *In* The American Academy of Orthopaedic Surgery Presents Lectures on Reconstruction Surgery. Ann Arbor: Edwards Bros., Inc., 1944, pp. 276-283.

when it was impossible to obtain a perfect nerve suture in an unscarred field. Function in the extremity could usually be restored to almost normal.

The exact type of procedure used seemed to make no great difference. Excellent results were secured with a variety of techniques, provided certain requirements were met, as follows:

1. The transplanted muscles must be strong enough to hold the wrist and fingers in extension without tiring. The palmaris longus is often weak and is sometimes missing, and, for this reason, it is unwise to count upon it to provide strong extension of any finger or of the thumb. The flexor carpi radialis and the flexor carpi ulnaris, on the contrary, are strong muscles, which can be freely mobilized without disturbing their nerve and blood supply. They can therefore be brought around the radial and ulnar aspects of the forearm, respectively, to provide strong extension of the fingers and thumb (fig. 274). The palmaris longus is left intact to provide flexion of the wrist.

2. Occasionally, after muscle transplantation, function returns in a radial nerve which has been considered permanently paralyzed. This usually results in a hyperextension deformity of the wrist with the fingers flexed, and the transplanted flexor muscles must be replaced in order to restore muscle balance. This is not an unduly difficult procedure, and the remote possibility of spontaneous recovery is therefore not a valid reason for delaying transplantation of the flexors into the extensors.

3. Normally, the thumb and index finger function together. When the thumb rotates and flexes in the position of opposition, the index finger flexes to meet it. When the hand is spread out, the thumb and index finger extend simultaneously. For these reasons, it is advisable to use the flexor carpi radialis to provide extension of both the thumb and the index finger as well as abduction of the thumb. The tendon is threaded through the abductor pollicis longus, the extensor pollicis brevis, the extensor pollicis longus, and the extensor indicis proprius.

4. The remaining fingers usually flex together in the position of grasp or are extended simultaneously when the hand is spread. For this reason, the flexor carpi ulnaris is transplanted into the common extensors of the fingers and the extensor digiti quinti proprius (fig. 275).

5. If the nerve injury is below the elbow, the extensor carpi radialis longus will still be functioning, and there will be adequate power to dorsiflex the wrist. When the damage has been above the elbow, the lost power of dorsiflexion of the wrist can be restored by freeing the pronator radii teres from its insertion into the radius and threading it into the extensor carpi radialis longus and the extensor carpi radialis brevis.⁶ It was the practice of some orthopedic surgeons to supplement the transplantation of the two flexors of the wrist by transplantation of the pronator radii teres into the

⁶ (1) Jones, R.: Tendon Transplantation in Cases of Musculospiral Injuries Not Amenable to Suture. *Am. J. Surg.* 35 (o.s.): 333-335, November 1921. (2) Tubby, A. H.: Deformities Including Diseases of the Bones and Joints. New York: Macmillan & Co. Ltd., 1912, vol. 2, pp. 740-764.

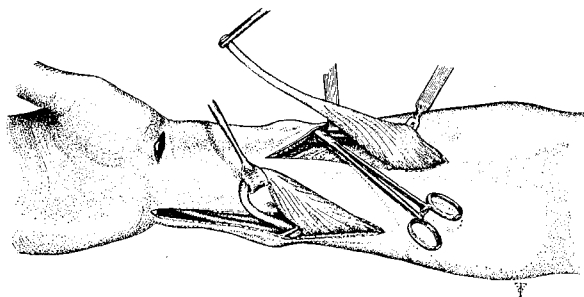

FIGURE 274.—Transplantation of flexors of forearm to extensors of fingers and thumb for radial nerve paralysis. The strong flexor carpi radialis and flexor carpi ulnaris muscles are freely mobilized through incisions on the flexor surface of the forearm.

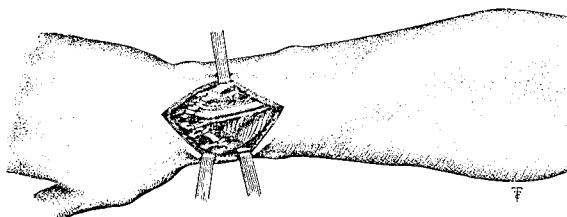

FIGURE 275.—Transplantation of flexors of forearm to extensors. The flexor carpi radialis is inserted into the extensors of the thumb and into the extensor proprius of the index fingers. The flexor carpi ulnaris is inserted through the extensor proprius of the little finger and into the common extensors of the other fingers. Strong extension of the fingers and thumb will result. If the nerve injury is above the elbow, transplantation of the pronator radii teres into the extensor carpi radialis brevis will provide strong active extension of the wrist.

radial extensors. If the radial nerve paralysis has persisted for some time, there is often a pronation deformity as well as a wristdrop, and this additional procedure will not only reinforce the paralyzed wrist extensors but also may correct the pronation deformity. Capt. (later Maj.) Vincent J. Turco, MC, demonstrated at Lawson General Hospital, Atlanta, Ga., that it was better to insert the pronator radii teres into the extensor carpi radialis brevis only, instead of into both the brevis and longus, as in the technique described by Tubby. Because the extensor carpi ulnaris is paralyzed, the hand goes into radial deviation during dorsiflexion of the wrist when the pronator teres is inserted into both radial extensors. Because the insertion of the extensor radialis brevis is into the base of the third metacarpal bone, radial deviation of the hand does not occur when the pronator teres is transplanted only into this muscle.

Operations for Ulnar Nerve Paralysis

Although loss of function of the ulnar nerve produces a characteristic deformity, it does not represent a major disability. Many soldiers with

complete ulnar nerve paralysis could perform full duty. A partial lesion of this nerve, however, could cause so much pain in the ulnar distribution that the patient protected the entire extremity and used it only when he was forced to. If paresthesia and dysesthesia persisted in the ulnar distribution after transplantation of the ulnar nerve to the front of the elbow or after neurolysis or nerve graft, the same situation occurred; the man would not use the extremity and therefore had a much greater handicap than a person with a complete ulnar lesion.

In some instances in which there had been extensive soft-tissue damage and the nerve lay embedded in a mass of scar tissue, the prognosis for restoration of ulnar nerve function was thought to be so poor that section of the nerve well above the site of injury was considered justified. This simple procedure, which is so successful in relieving pain when any purely sensory nerve is hopelessly involved in scar tissue, was always kept in mind in the management of partial lesions of the larger nerves. After severance of this nerve, accommodation to the absence of sensation in the little finger and to lack of power in some of the intrinsic muscles of the hand was so complete that the loss of ulnar function was not complained of. This has repeatedly been observed in civilian practice when complete severance of this nerve has occurred in childhood.

In neurosurgical centers, prolonged hospitalization and complicated surgical procedures for correction of paralysis of the ulnar nerve were considered of doubtful value and seldom justified. It was much more sensible to convince the patient that his handicap was minor and to induce him to engage in some gainful occupation in which he would learn to compensate for the loss of ulnar function and cease to concentrate upon it. Orthopedic operations designed to correct ulnar nerve paralysis were seldom regarded as indicated unless there had been associated damage to the median nerve and flexor tendons.

Operations for Median Nerve Paralysis

Irreparable damage to the median nerve, because it produces loss of sensation and power in the thumb and the index finger, renders the hand, and the entire upper extremity along with it, almost useless. If the ulnar nerve had been spared in a battle-incurred injury, considerable useful function could be reestablished. When attempts to restore sensation in the median distribution had failed, not much functional improvement could be expected.

Development of a claw-hand deformity of some degree was almost inevitable following any lesion of the median or ulnar nerve; the deformity was most unsightly and was completely disabling when the injury was combined. If the injury had been low enough to spare the innervation to the flexor muscles in the forearm, the most satisfactory way of overcoming the deformity was to use the sublimis tendons as substitutes for the paralyzed

lumbricales and interossei, as described by Bunnell.⁷ These tendons could be sectioned near their insertions, brought up through a palmar incision, and threaded down through the lumbrical canals. If they were split well up into the palm, eight slips of tendons were available for reinsertion into the extensor aponeuroses of the fingers (fig. 276). When their courses were altered, these tendons would no longer flex the middle phalanx on the proximal phalanx, but they would produce flexion at the metacarpophalangeal joints and extension of the distal phalanges. It was sometimes possible to arrange the insertions so that a certain amount of adduction and abduction of the individual fingers was also accomplished. Appropriate muscle transplantations were employed for injuries of individual branches of the ulnar and median nerves.

The most important function of the hand is opposition of the thumb to the fingers. It is therefore not strange that numerous complicated procedures devised to restore this function⁸ were employed during World War II.

One technique, the use of a graft between the first and second metacarpal shafts, has already been mentioned (p. 571). Another technique⁹ sometimes employed was simple posterior dislocation of the base of the first metacarpal, to put the thumb in a position of moderate opposition. Another very simple method employed in some neurosurgical centers was the Thompson modification of the Royle operation¹⁰ (figs. 277 and 278). By this technique, the flexor sublimis tendon of the middle or ring finger is brought out through the palm and run subcutaneously across the thenar eminence. The lower border of the transverse carpal ligament forms a smooth pulley for the transplanted tendon, which is split and inserted into the distal end of the first metacarpal bone and the base of the proximal phalanx of the thumb. The transplanted tendon thus runs in the same direction as the fibers of the paralyzed opponens pollicis.

If the transplanted muscle was strong enough and all fixed deformity had been corrected, one or another of these procedures restored almost normal opposition of the thumb and first finger. Moreover, since opposition of the thumb and flexion of the fingers normally take place together, as two parts of a pinching action, little or no reeducation of the transplanted muscle was needed. It was absolutely essential, however, that the deformity be completely corrected and that an osteotomy be done at the base of the first metacarpal if the thumb did not readily rotate into a position of real opposition.

⁷ Bunnell, Sterling: *Surgery of the Hand*. Philadelphia: J. B. Lippincott Co., 1944.

⁸ (1) Bunnell, Sterling: *Opposition of the Thumb*. *J. Bone & Joint Surg.* 20: 269-284, April 1938. (2) Irwin, C. E.: *Transplants to the Thumb to Restore Function of Opposition: End Results*. *South. M.J.* 35: 257-262, March 1942. (3) Ney, K. Winfield: *A Tendon Transplant for Intrinsic Hand Muscle Paralysis*. *Surg. Gynec. & Obst.* 33: 342-348, October 1921. (4) Royle, N. D.: *An Operation for Thenar Paralysis*. *M.J. Australia* 2: 155-156, 1 Aug. 1936. (5) Royle, N. D.: *An Operation for Paralysis of the Intrinsic Muscles of the Thumb*. *J.A.M.A.* 111: 612-613, 13 Aug. 1938. (6) Steindler, A.: *Flexor Plasty of the Thumb in Thenar Palsy*. *Surg. Gynec. & Obst.* 50: 1005-1007, June 1930.

⁹ Fitch, Ralph R.: *An Operation To Improve the Condition of Hands Disabled by Paralysis of the Opponens Pollicis*. *J. Bone & Joint Surg.* 12: 190, January 1930.

¹⁰ Thompson, T. C.: *A Modified Operation for Opponens Paralysis*. *J. Bone & Joint Surg.* 24: 632-640, July 1942.

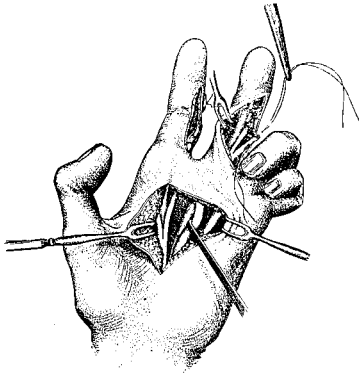

FIGURE 276.—Transplantation of flexor digitorum sublimis tendons for claw-hand deformity. Following median or ulnar paralysis, the transplantation of flexor digitorum sublimis tendons through the lumbrical canals into the extensor expansions will, in a large measure, restore active flexion of the metacarpophalangeal joints.

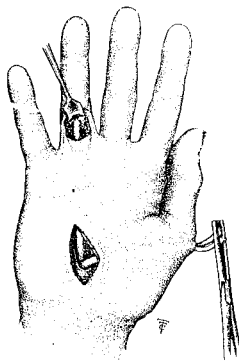

FIGURE 277.—Transplantation of flexor sublimis tendon into thumb to restore power of opposition (Thompson modification of Royle operation). The flexor sublimis tendon to the ring or middle finger is sectioned at the base of the finger and brought out through a palmar incision. The distal margin of the transverse carpal ligament acts as an excellent pulley for the transplanted tendon as it runs subcutaneously across the thenar eminence.

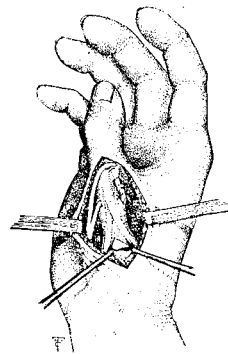

FIGURE 278.—Transplantation of flexor sublimis tendon into thumb to restore power of opposition. The thumb is first rotated into a position of full opposition. An osteotomy at the base of the first metacarpal bone is performed if necessary. Good active opposition is then maintained by threading one segment of the transplanted sublimis tendon through a hole in the distal end of the metacarpal and the other through a subperiosteal tunnel at the base of the first phalanx.

OPERATIONS ON THE LOWER EXTREMITY

Orthopedic procedures in irreparable nerve injuries in the lower extremities are directed primarily toward correction of deformity, with elimination of the muscle imbalance which has caused the deformity second in importance. Only in the occasional case is it possible to improve muscle function, eliminate limp, and increase endurance. The situation is not as hopeless as it sounds. A person can walk quite well upon a completely paralyzed extremity or upon an artificial leg if the joints are so locked that the parts are in a good weight-bearing position.

The extensors of the hip and knee and the flexors of the foot and ankle are of great assistance in accomplishing this objective. Muscle transplantation to reinforce these muscle groups was therefore sometimes considered, but the procedure was not usually practical, for muscles with strength great enough to justify transfer were seldom available in a badly damaged limb.

In paralysis of the quadriceps, one or more of the hamstrings were sometimes transplanted forward. The improvement which resulted was chiefly due to correction of the slight flexion contracture of the knee which had developed as a result of shortening of the unopposed hamstring muscles. Since all the muscles in the thigh contract simultaneously to stabilize the knee in the first part of the weight-bearing phase of gait, no special re-education of the transplanted muscle was necessary.

Operations for Paralysis Below the Knee

In any attempt to restore function in the lower extremity, the foot was considered first, since it is a stable pedestal during stance and a strong lever during walking.

Relief of pain.—Pain in the foot or referred to the foot was usually aggravated by weight bearing and represented a major disability. Severe pain on walking was frequently the result of contractions of tendons or muscles, particularly if the nerves were adherent. A painful partial lesion was much more disabling than a complete lesion.

Radical excision of scarred muscle, lengthening of contracted tendons, and, above all, freeing of nerves from scar tissue in the foot and leg were undertaken whenever an injured extremity continued to be painful. If scarring was intraneural or if the nerve had to be replaced into a bed of scar tissue, high section of the nerve often resulted in more functional improvement than could be accomplished by neurolysis or nerve suture.

When purely sensory nerves were involved, section of the nerve above the area of scarring was practically always preferable to suture. Even in the larger nerves, section was usually the operation of choice if it was thought that the injured nerve trunk was apt to remain painful. Section of the sciatic nerve, however, like section of the median nerve, was not the proper treatment for causalgia.

Correction of clawing.—After section of the posterior tibial nerve in the calf, there was usually a tendency toward cavus deformity of the foot and clawing of the toes. It was seldom severe enough, however, to warrant any procedure more radical than correction of the deformities of individual toes by arthrodeses of the interphalangeal joints, capsulotomy, or transplantation of the long flexor muscles into the extensors. If clawfoot was severe, transplantation of all the extensor tendons into the necks of the metatarsals, together with plantar fasciotomy, was sometimes necessary to flatten the foot and correct the deformities of the toes.

Stabilization of the foot.—When musclepower was completely lost below the knee, every effort was made to produce in the foot a stable pedestal for standing and a lever for walking. An amputee who has a well-fitted prosthesis can walk without any appreciable limp, and, similarly, a carefully planned foot-stabilizing procedure could produce the same result in a limb with irreparable nerve damage. Which one of the numerous operations designed to correct paralysis and deformity of the foot was selected in the individual case was not important provided that the following criteria were met:

1. The plantar surface of the foot must be smooth and must be in such a position that the weight of the body is distributed over the entire plantar area.

2. There must be good lateral stability when the foot is placed upon the ground, even though the inverting and everting muscles are paralyzed.

3. The foot must be in such a position beneath the leg that the normal pushoff from the metatarsal heads is reestablished.

4. The foot must be painless. Complete anesthesia is preferable to paresthesia or dysesthesia.

5. Whenever possible, ankle joint motion should be retained within a limited range. If this is not practical and ankle fusion is necessary, the alinement of the extremity upon the foot should be such that good function is still possible.

6. The foot should fit into an ordinary shoe, and supporting braces should be unnecessary.

Of the numerous operations devised for foot stabilization,¹¹ posterior bone blocks,¹² tenodeses, and tendon transplantations¹³ were frequently used and gave good results. In the equinus and equinovarus deformities which followed peroneal or complete sciatic nerve paralysis, the Lambrinudi procedure¹⁴ (figs. 279 and 280), which involves removal of appropriate bone wedges in the subastragalar and midtarsal joints, accomplished correction of the deformity with mathematical precision.

¹¹ (1) Dunn, N.: Stabilizing Operations in the Treatment of Paralytic Deformities of the Foot. *Proc. Roy. Soc. Med. (Sect. Orthop.)* 15: 15-22, 6 Dec. 1921. (2) Hoke, M.: On Operation for Stabilizing Paralytic Feet. *J. Orthop. Surg.* 3: 494, October 1921. (3) McCarroll, H. Relton: Foot Deformities Resulting From Irreparable Nerve Lesions. *In The American Academy of Orthopaedic Surgeons Presents Lectures on Reconstruction Surgery.* Ann Arbor: Edwards Bros., Inc., 1944, pp. 149-168. (4) White, J. Warren: Disorganization of the Foot. *In The American Academy of Orthopaedic Surgery Presents Lectures on Reconstruction Surgery.* Ann Arbor: Edwards Bros., Inc., 1944, pp. 129-136.

¹² (1) Campbell, W. C.: An Operation for the Correction of "Drop-Foot". *J. Bone & Joint Surg.* 5: 815-825, October 1923. (2) Wagner, L. C.: Modified Bone Block (Campbell) of Ankle for Paralytic Drop Foot. With Report of Twenty-Seven Cases. *J. Bone & Joint Surg.* 13: 142-148, January 1931.

¹³ (1) Mayer, L.: The Operative Treatment of Paralytic Deformities of the Foot. *Am. J. Surg.* 7 (n.s.): 80-88, July 1929. (2) Mayer, L.: The Physiological Method of Tendon Transplantation. *Surg. Gynec. & Obst.* 22: 182-197, February 1916. (3) Mayer, L.: The Physiological Method of Tendon Transplantation in the Treatment of Paralytic Foot-Drop. *J. Bone & Joint Surg.* 19: 389-394, April 1937.

¹⁴ Lambrinudi, C.: New Operation for Drop Foot. *Brit. J. Surg.* 15: 193-200, October 1927.

Operations for Peroneal Nerve Paralysis

In the lower extremity, any direct injury in the region of the knee may produce peroneal nerve paralysis. As the nerve winds around the head of the fibula, it is practically subcutaneous, and it was therefore even more vulnerable to combat injuries than the radial nerve in the upper extremity. The injury often involved a considerable extent of the nerve, and suture was difficult or entirely impossible.

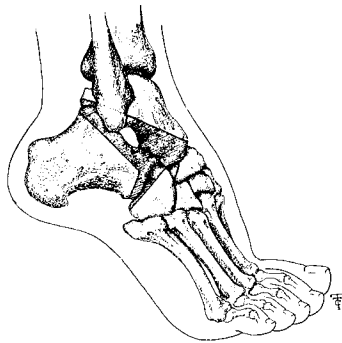

FIGURE 279.—Lambrinudi operation to correct equinus and varus deformities. Removal of an appropriate bone wedge through the subastragalar joint corrects the equinus and inversion of the heel. Removal of a wedge of bone through the calcaneocuboid joint corrects adduction of the forepart of the foot and the cavus deformity of the foot.

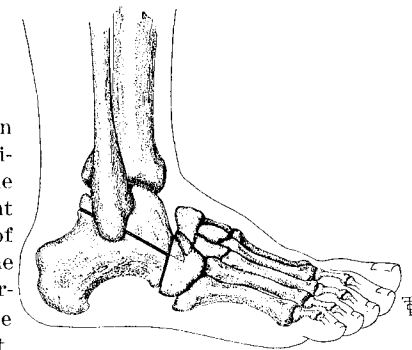

FIGURE 280.—End result of Lambri-nudi subastragalar arthrodesis. After correction of the deformity by removal of subastragalar and midtarsal bone wedges, the foot is in a stable, weight-bearing position. As the astragalus remains in equinus, a physiologic bone block is established. Recurrence of the deformity is prevented by impingement of the posterior tip of the astragalus against the posterior tip of the tibia.

In the arm, this problem could be solved by flexing the elbow to permit end-to-end suture, since flexion is the usual position of the elbow when the hand is active. In the lower extremity, acute flexion of the knee was scarcely ever justified in an attempt to obtain a good end-to-end suture, since even slight flexion deformity of the knee entirely upsets the weight-bearing function of the leg; the patient has to walk with the limb flexed and becomes fatigued on standing. Another factor that discouraged the use of such a procedure was the notoriously poor results of suture of the peroneal nerve.

In soldiers who had had extensive injuries of the leg, it was usually possible to prevent the development of equinovarus deformity by immobilization of the limb in plaster in good position, followed by constant support in a well-designed brace. As soon, however, as it was recognized that the injury of the peroneal nerve was likely to be permanent, some operative procedure was undertaken to eliminate the use of a brace. When

all the extensors and evertors of the foot are paralyzed, the constant pull of the strong, unopposed tibialis posticus is the chief cause of the varus deformity. Early transplantation of this muscle was therefore undertaken, not only to prevent development of varus but also to help overcome the tendency toward equinus. If necessary, the transplantation operation was supplemented by subastragalar and midtarsal arthrodesis.

It was entirely feasible to transplant the tibialis posticus muscle directly forward through a large opening in the interosseous membrane. This method was generally used by Captain Turco, at the neurosurgical center at Valley Forge General Hospital, Phoenixville, Pa., with superior results.

At the Thomas M. England General Hospital, Atlantic City, N.J., the technique devised by Maj. R. Nelson Hatt, MC, also gave good results. The operation (figs. 281, 282, and 283) is performed as follows:

A 5-cm. incision is made over the middle cuneiform, and the dissection is carried down just lateral to the dorsalis pedis vessels. A drill hole 0.625

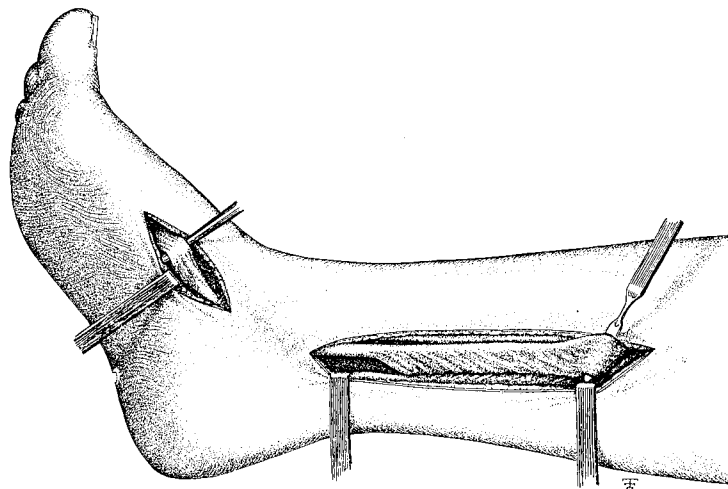

FIGURE 281.—Transplantation of tibialis posticus to dorsum of foot for correction of equinovarus deformity. This strong muscle can be used to overcome the varus and equinus deformities which usually follow peroneal nerve paralysis. The muscle is freely mobilized to allow it to function well in its transplanted position.

cm. in extent is made obliquely downward and inward, drilling being continued until the point of the drill can be felt at the inner border of the foot, approximately opposite the inferior aspect of the first cuneiform bone.

A short curved incision is next made over the insertion of the tibialis posticus muscle.

A third incision begins at a point just posterior to the medial malleolus and extends upward approximately 12 to 15 cm.

The tendon of the tibialis posticus muscle is detached at its insertion, and the aponeurotic portion is dissected forward (fig. 281). Without this dissection, it is a little short when transposed.

The tendon is then pulled up through the third incision, and the muscle belly is stripped upward until the tendon can be swung forward in a straight line with the dorsal incision on the foot.

FIGURE 282.—Transplantation of tibialis posticus to dorsum of foot for correction of equinovarus deformity. A strong suture is inserted into the end of the transplanted tendon, and the tendon is drawn firmly down with it into a hole drilled through the second cuneiform bone.

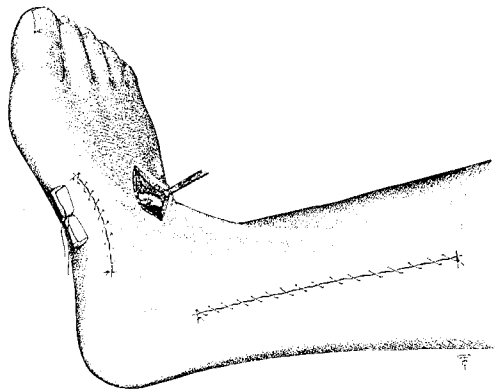
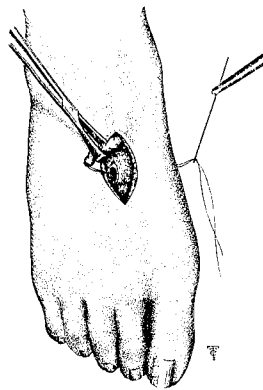

FIGURE 283.—Transplantation of tibialis posticus to dorsum of foot for equinovarus deformity. With the foot held in valgus and dorsiflexion, the ends of the suture are tied over a small roll of gauze. The action of this tendon in its transplanted position largely restores muscle balance in the foot and prevents recurrence of the deformity.

A tunnel is made through the subcutaneous fat by passing a hemostat up from below, and the tendon is brought down through this tunnel to the dorsal incision. With the foot in full dorsiflexion, an estimate is made of the amount of tendon to be drawn down through the drill hole, and the section to be used is denuded of epitendon and peritendon.

A through-and-through suture of No. 12 cotton is begun at the end of the tendon. The ends of the suture are threaded on a long Keith needle,

guided through the drill hole by means of a grooved director, and brought out through the skin at the medial aspect of the foot (fig. 282). By grasping the ends of the suture, it is possible to pull the tendon well down into the drill hole with the estimated degree of tension on the muscle belly. The ends of the suture are tied over a rolled sponge placed between them, the tendon thus being anchored in the correct position. A possible modification of the technique is to bring the needle out through the second incision and suture the ends of the cotton through the fascia over the first cuneiform. Two small stay sutures of No. 80 cotton are placed through the tendon and periosteum at the entrance to the tunnel. For further security, a slip of the tibialis anticus tendon is split off and sutured into a small slit in the transplanted tibialis posticus (fig. 283).

The three incisions are closed, and a plaster boot is applied, with the foot at a right angle and in slight valgus. The plaster is bivalved at the end of 4 weeks. The suture in the tendon is removed by cutting the thread on one side and pulling on the other end.

At this time, a toe drop brace is applied, and physiotherapy is begun. A split plaster cast is worn at night for 4 to 6 weeks. At the end of this period, the brace is also discarded.

Injuries of the external popliteal nerve were often associated with fractures of the upper end of the fibula or with both bones of the leg. In such cases, the treatment of the fracture usually required prolonged immobilization of the leg and foot. In the upper extremity, such a situation was extremely serious; the resulting stiffness of the fingers, hand, and wrist caused permanent, often extreme, disability, and it was therefore avoided, even at the risk of insufficient splinting of fractures of the bones of the forearm or inadequate support of paralyzed muscles.

In the lower extremity, however, the stiffness that occurred in the foot and the fibrosis that developed in the paralyzed extensor muscles were really assets; they prevented the development of the severe equinovarus deformity to be expected in complete paralysis of the peroneal nerve. When this deformity developed, it was necessary to perform an arthrodesing operation in the subastragalar and midtarsal region, to correct supination and adduction of the foot and limit downward motion at the ankle. This operation, although it did not restore active dorsiflexion, did produce a very satisfactory weight-bearing foot. It was most important, however, that alinement be perfect.

CONCLUSIONS

1. It should be clearly understood that, whenever a peripheral nerve has been damaged so severely that its function cannot be restored, orthopedic procedures, while they are frequently useful, cannot be expected to restore the patient to his normal functional status.

2. The procedures described in this chapter had a definite field of usefulness in World War II, but they did not restore normal sensation or motor power to muscles supplied by nerves which had been irreparably injured.

3. The chief value of these orthopedic procedures was to restore some balance between the remaining active muscles, thus correcting or preventing deformity and generally improving function in the injured extremity.

APPENDIX A

ASF Circular } No. 25 } PART ONE.	HEADQUARTERS ARMY SERVICE FORCES Washington 25, D.C., 22 JANUARY 1945	Section I
PATIENT IN HOSPITAL—Sec. II, ASF Cir. 374, 1944, amended_____		
PART TWO.		
PATIENT IN HOSPITAL—Sec. IX, ASF Cir. 374, 1944, clarified_____		
WAR DEPARTMENT FILM—For civilian initiative, incentive, and morale purposes _____		
ARMY SPECIALIZED TRAINING PROGRAM—Report on former dental and veterinary trainees _____		
PART THREE.		
INSTALLATION—Redesignation, Armed Forces Radio Service School, Los Angeles, California _____		
SHIPMENT—Replacement of shipments lost at sea _____		

PART ONE

(General application—complete distribution)

I—PATIENT IN HOSPITAL.—1. Paragraph 1c (1) and (2), section II, ASF Circular No. 374, 1944, is rescinded and the following substituted therefor:

(1) *White enlisted men.*

(a) Armored: Armored Replacement Training Center, Fort Knox, Kentucky.

(b) All other personnel of the arms and services, and personnel without arm or service, with the AGF, Infantry advanced replacement training centers—

Camp Howze, Texas

Camp Livingston, Louisiana

(2) *Colored enlisted men.*—All colored enlisted personnel reassigned under the provisions of this paragraph, including armored, will be ordered to the Infantry Advanced Replacement Training Center, Camp Livingston, Louisiana.

2. Section I, ASF Circular No. 390, 1944, is rescinded.

(SPX 220.3 (19 Jan 45)SPGAC)

PART TWO

(Limited application—special distribution)

II—PATIENT IN HOSPITAL.—1. Reference is made to paragraph 2a, section IX, ASF Circular No. 374, 1944.

2. In view of the present lack of uniformity in interpretation of the provisions of this paragraph, the following clinical criteria are submitted as guides in ascertaining maximum benefit of hospitalization in cases of paraplegia or transverse myelitis:

a. *Wounds and pressure sores.*—Wounds and pressure sores should be completely healed. No further surgery should be anticipated.

b. *Bladder and bowel function.*—Every attempt should be made to establish an automatic bladder and eliminate bladder infection. Satisfactory bowel function should also be obtained.

c. Extremity function.—Every effort should be made to achieve restoration of muscular function in the lower extremities by utilizing physical therapy, proper braces, crutches, and other devices, such as “walkers.”

d. Taking into consideration *a*, *b*, and *c* above, these patients should be discharged to Veterans Administration jurisdiction under current directives when progress appears to have leveled off and no further substantial improvement can be anticipated.

(SPX 220.8 (16 Jan 45)SPMCR)

(*Minimum distribution:* Regional, station, and general hospitals.)

III—WAR DEPARTMENT FILM.—1. Distribution will be made, upon a circuit basis, of prints of selected films for exhibition to civilian employees in Army Ground Forces, Army Air Forces and Army Service Forces installations, beginning with the release for the month of February 1945, due to begin its circuit during the latter part of January 1945, this release being a film entitled “Suggestion Power” referred to in section I, ASF Circular No. 420, 1944. Initially, distribution will be made upon a basis of one subject per month.

2. The films to be so circuited will be used primarily for the purpose of developing civilian morale, incentive, and initiative, and may also be made available for information and education purposes to such military personnel of Army Ground Forces, Army Air Forces and Army Service Forces as may be determined by the commanding officers of field installations. Films so distributed will previously have been approved for such showing to military personnel by the Director, Information and Education Division, Army Service Forces. Circuits will be operated by the various numbered service commands and the Military District of Washington, the circuits to include all military installations within the commands, including those of the Army Air Forces, as may desire bookings. All bookings, control of the circuits, and the notification of circuits will be accomplished by the central film library of each service command, to which all requests for bookings and all correspondence from field installations relative to exhibition of these films should be addressed.

3. Notification of circuit bookings will be given by the central film library of each of the commands concerned approximately 2 weeks in advance of the showing date.

* * * * *

BY COMMAND OF LIEUTENANT GENERAL STYER:

OFFICIAL:

J. A. ULIO,
Major General,
The Adjutant General.

LER. LUTES,
Major General, G.S.C.,
Acting Chief of Staff.

APPENDIX B

War Department Technical Bulletin (TB Med) 162

CONVALESCENT CARE AND REHABILITATION OF PATIENTS WITH SPINAL CORD INJURIES

War Department, Washington 25, D.C.

MAY 1945

1. **PURPOSE.** A defeatist attitude is intolerable in the care of patients with traumatic transverse myelitis. Rehabilitation can and must establish a wheel-chair life for the majority and walking with aid of braces or crutches for many. Self-support at a sedentary occupation is the ultimate objective. Maximal rehabilitation is essential for the preservation of morale and human dignity. It is the function of general hospitals in the zone of interior to effect this degree of rehabilitation *prior to final discharge of the patient*. It is the purpose of this bulletin to summarize experience and establish policies for professional care during the rehabilitation of patients with irrevocable spinal cord injuries.

2. **GENERAL CONSIDERATIONS.** The emergency management and initial surgical treatment of spinal cord injuries are beyond the scope of this bulletin. Transportation splinting and preparation for evacuation are the responsibilities of oversea installations.

a. Spinal cord injuries are generally of two types: simple vertebral fracture with cord compression or *transection*; and penetrating wounds with direct injury of the cord.

(1) Major vertebral fractures usually require splinting and support for 3 months. They are properly evacuated in well-fitting plaster jackets.

(2) Penetrating wounds of the spinal cord with minimal bone damage rarely require plaster splinting. The use of plaster jackets for the evacuation of these patients has been discouraged.

b. Experience in the care of patients during evacuation has established the need for suprapubic cystostomy. Most of the objections to this procedure can be overcome by placing the tube as nearly as possible in the dome of the urinary bladder. (See TB MED 147, March 1945.)

c. The paralyzed patients present immediate and continuing problems in special nursing care. Even before the stability of the vertebral fracture is assured, a rigorous program must be instituted to *teach the patient to care for himself*. This requires the constant attention and integrated industry of medical officers, nurses, physiotherapists, and hospital corpsmen.

d. The morale of patients is sustained by *group care on large open wards*. Air conditioning is desirable during the warm months. The observed progress of a fellow casualty is a powerful stimulus to continued cooperation in a long and arduous program of rehabilitation. Group care facilitates the recognition of common difficulties and methods of adaptation from patient to patient. Group care encourages group instruction, collective occupational therapy, and the institution of training programs for self-support in sedentary jobs. The ward diversion and decoration should be the assigned responsibility of one or more Red Cross workers educated in the special problems of the paraplegic patients.

e. Intelligent coordination of diverse professional interests is essential to the successful administration of the program. The integration and effective execution of this program should be the sole responsibility of one medical officer. This officer should be chosen on the basis of enthusiasm, diligence, and broad experience. He need not be

primarily a neurosurgeon or urologist. The specialized character of care and the importance of patient-personnel friendship demand semipermanent assignment of specially selected nurses and corpsmen.

3. NURSING CARE. Special attention must be devoted to the care of the skin and the prevention of decubitus ulcers. The anesthetic skin has no inherent vulnerability to trauma but in the absence of pain is more severely traumatized than normal skin. Sustained pressure over a bony prominence produces absolute ischemia of the skin in that area. It is believed that maintained pressure for 3 to 4 hours may be sufficient to produce skin necrosis. The subcutaneous tissues are more vulnerable than skin to this trauma. Consequently, when skin erosion and slough occur, the decubitus lesion is often undermined.

a. There is only one way to prevent ulceration of the anesthetic skin. *The position of the patient should be changed at regular intervals of 2 hours.* In addition, the skin overlying such bony prominences as the sacrum, hips, ankles, heels, and elbows should be protected by pillows, pads, or rings. A surgical pad should be placed over the perineum to minimize soiling from fecal incontinence. The perineal and pelvic pads should be secured by a binder around the entire midriff. The binder should be of material of sufficient thickness to protect the skin from friction burns during the process of turning the patient. The perineum should be promptly and thoroughly washed with soap and water, dried, and powdered after each escape of feces.

b. The standard Army felt mattress supported by fracture boards is the bedding of choice. Air, "foam" rubber, or other special *soft mattresses are not to be used.* Such mattresses make it difficult to change the patient's position and are conducive to muscle contractures. Pillows may be used to increase postural comfort in the hard bed.

c. The bed linens should be kept clean and smooth. Sheets should be tightened after each change of the patient's position.

d. The Stryker frame is an excellent device for the care of the patient during the period of spinal instability. Seriously ill or uncomfortable patients may be turned and handled expeditiously even in the absence of trained personnel. It may also be used to facilitate indicated surgical procedures.

4. NUTRITION. Patients with spinal cord injury frequently show evidence of malnutrition. Blood loss from associated wounds at the time of injury may have been severe. Lowered morale, difficult self-feeding, ileus, and persistent urinary tract infection are factors further favoring reduced caloric intake and ineffective utilization of ingested foodstuffs.

a. *Whole blood transfusions* are more desirable than infusions of plasma or amino acids. Persistent urinary tract infection may retard erythropoiesis. Correction of persistent secondary anemia by transfusion facilitates the flow of new food protein mainly to the synthesis of needed tissue protein. It should be remembered that the quantitative estimation of the concentration of hemoglobin does not necessarily reflect the true quantity of total circulating hemoglobin. The minimally acceptable levels for convalescence are a hematocrit of 40 percent (copper sulfate method) or an hemoglobin of 14 grams percent (photometer determination). It is essential to establish these red blood cell values before attempting to interpret the significance of observed plasma protein concentration.

b. The *caloric* intake should be maintained at 3,500 calories daily. This may require feeding by ward personnel at first. Interval nourishment should be given between meals and at bedtime. The dietitian should supervise the preparation of meals and check on consumption by individual patients. Special feeding problems should be given skilled consideration.

c. The *protein* intake should be at least 125 grams per day.

d. The *vitamin* intake should be adjusted, by supplement if necessary, to provide a *minimum* of 5,000 I. U. vitamin A, 2 mgm thiamin, 3 mgm riboflavin, 20 mgm niacin,

75 mgm ascorbic acid, and 400 I. U. vitamin D. The routine use of mineral oil as a laxative interferes with the absorption of fat-soluble vitamins and is not recommended.

c. A fluid intake of 3,500 to 4,000 cc. is a desirable supplement to the treatment of the urinary tract.

5. CARE OF BOWEL. Intestinal tone and peristalsis are diminished after spinal cord injury. Ileus and obstipation are followed by constipation and sluggish fecal evacuation. Fecal incontinence and impaction are to be expected until autonomic function of the bowel is established.

a. Enemata should be given at regular intervals, at least every 3 days. Complete evacuation of the rectum should be ascertained by digital examination after each enema.

b. Regular bowel habits should be fostered. The laxative effects of various articles of the diet should be utilized to encourage regularity. Other laxatives and cathartics are not recommended. Regular bowel habits are to be expected as part of maximal recovery.

6. MANAGEMENT OF SUPRAPUBIC CYSTOSTOMY. Immediately after severe injury of the spinal cord the bladder becomes atonic or hypotonic, presumably because of detrusor paralysis. Atonicity may prevail for an unpredictable period of days or months. Ultimately, there is to be expected an automatic phase of micturition characterized by periodic vigorous contractions of the detrusor muscle with evacuation of several ounces of urine at one time. Such voiding is involuntary and without sensation, usually at intervals of 1 to 3 hours. There is no leakage of urine during the interim. Complete emptying of the bladder is not assured but evacuation is reasonably efficient. In complete transverse lesions of the cord, the automatic phase of micturition is permanent. Return of voluntary control is possible with incomplete section of the cord. Every effort should be made to recognize the automatic phase which permits the removal of drainage tubes and catheters and encourages intermittent voiding. Morale is raised, ambulatory existence is more comfortable, and rehabilitation is accelerated after bladder function is resumed.

a. The *suprapubic tube* may be held in place by adhesive after sutures have been removed from the wound. No available drug, administered internally or introduced into the bladder, will sterilize the urine under the conditions of tube drainage of the bladder. Control of bladder infection depends upon the mechanical efficiency and cleanliness of the drainage system, avoidance of contamination during the change of catheters or equipment, and the maintenance of general nutrition and an adequate urine volume.

b. Routine *bladder irrigations* must be done at least 4 times each day. A closed system of drainage and irrigation is recommended. The equipment for the closed system, including the irrigation jar and tubing, should be sterilized by boiling or autoclaving before use. The apparatus should be cleaned and sterilized once each week.

(1) *The manually controlled closed system* (fig. 1) is the simplest and most fool-proof. The equipment for the assembly may be obtained from the Medical Supply

Catalog:

Item No. 4048500—Bottle, infusion, Kelly.

Item No. 4180800—Clamp, shut-off, screw adjustment.

Item No. 4464000—Tubing, rubber, special, $\frac{3}{16}$ -inch inside diameter, $\frac{1}{16}$ -inch wall, acid-cured.

Item No. 4002000—Adapter, Y tube, glass, 5-mm bore.

Item No. 4458000—Tubing, glass, 6-mm outside diameter.

The stem of the Y tube is connected to the suprapubic tube. The limbs of the Y tube are connected to rubber tubing leading on one side to the irrigation bottle and on the other to the collecting bottle. Most patients can be taught to irrigate their own bladder. The system may be disconnected to allow the patient up in a wheel chair. Air in the tube line does not interfere with function.

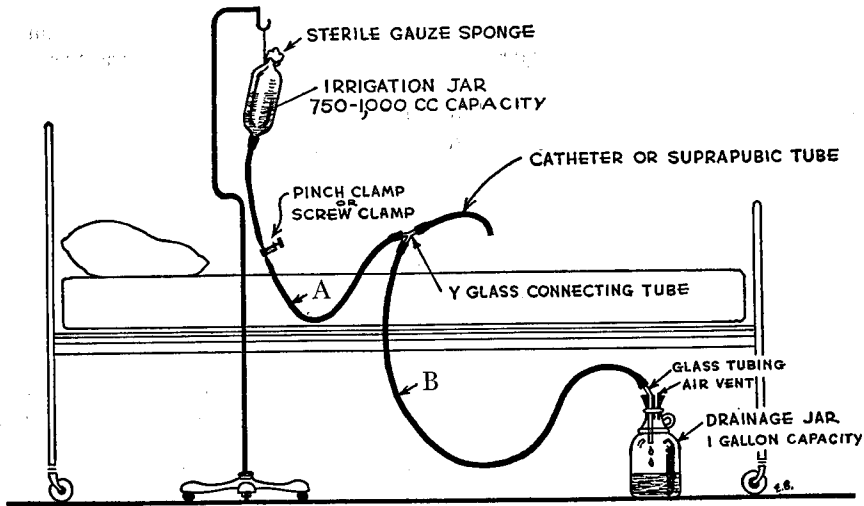

FIGURE 1.—Manually controlled closed system.

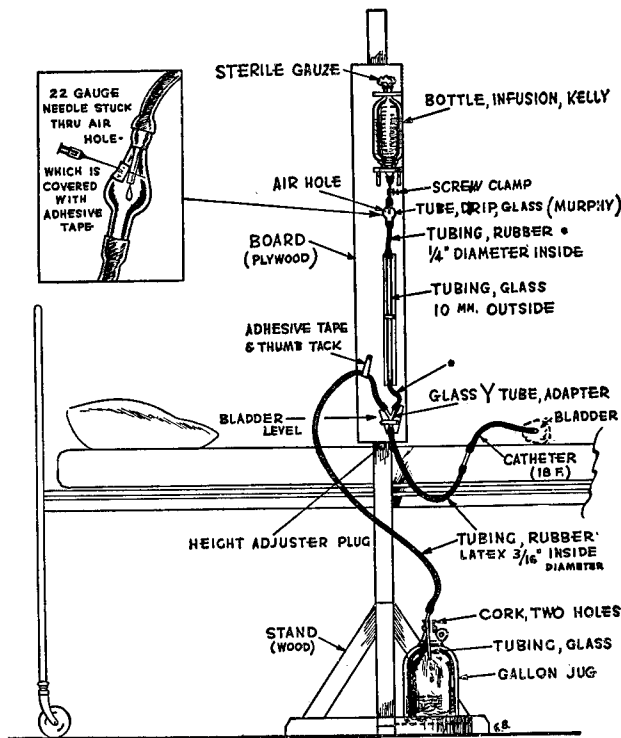

FIGURE 2.—Automatically controlled or tidal system.

(2) *The automatically controlled or tidal system of closed drainage* (fig. 2) requires for efficient operation the constant attendance of trained personnel. Knowledge of the individual dynamics of each paralyzed bladder is necessary for its correct use. Air in the tubing impairs the mechanical efficiency of the system—an inconvenience in the care of ambulatory patients. There are several systems of "tidal irrigation," and the essential equipment is available in the Medical Supply Catalog.

(3) A 2 percent solution of boric acid is a satisfactory irrigating solution. Solution "M" of Suby and Albright has the advantages of being mildly bacteriostatic and of dissolving phosphatic concretions on catheters and tubing. The formula for solution "M" is:

Citric acid	32.35 gm.
Sodium carbonate (anhydrous)	8.84 gm.
Magnesium oxide	3.84 gm.
Distilled water q.s.ad	1000 cc.

The solution should be autoclaved before use and may be tinted distinctively by the addition of methylene blue or other dye.

c. The suprapubic tube may be removed as soon as it appears that reflex bladder action would be adequate for automatic micturition. Prompt recognition of this phase of recovery is not always easy. Modified cystometric studies through the suprapubic tube and specific interrogation of patients as to bladder function should be undertaken regularly at intervals of 2 weeks to facilitate recognition of reflex bladder action. Removal of the suprapubic tube is warranted when the cystometric studies show a bladder capacity of 400 cc. or less, a normal or hypertonic curve, an atonic curve with maximal voluntary pressure of at least 60 cm of water, or urethral voiding. After removal of the suprapubic tube, there is likely to be continued leakage of urine with delayed closure of the cystostomy wound and maceration of the surrounding skin. For these reasons, the removal of the suprapubic tube is an indication for the *insertion of an urethral catheter*, sizes 18 F or 16 F, soft rubber, with two holes. Larger catheters are a source of complications and should be avoided. A self-retaining catheter may be used. The catheter should be fastened in place by adhesive tape to the skin of the penis. The tip of the catheter should be adjusted to give effective dependent drainage of the bladder. Urethral catheters should be changed and adjusted at intervals of 1 week.

d. Healing of the suprapubic wound is likely to be delayed. Excision of exuberant granulations and efficient urethral drainage of bladder urine are helpful adjuncts. Surgical closure of the cystostomy is rarely necessary.

e. Removal of the urethral catheter may be considered after the suprapubic wound is healed. Cystometric study showing evidence of good reflex activity, high maximum voluntary pressure, or both, or voiding around the catheter are features warranting a trial at voiding. No set cystometric values appear to be a completely reliable guide for the proper time to remove the catheter. Close observation of bladder efficiency is important during the period of trial at voiding. A residual urine of more than 100 cc is an indication for further catheter drainage. Overdistention of the urinary bladder should not be allowed. The efficiency of automatic bladder action fluctuates with the general condition of the patient. Constant vigilance to prevent overdistention is necessary even though reflex action appears satisfactory for the first few days after removal of the catheter.

f. Periodic X-rays for urinary tract calculi are suggested in patients immobilized in recumbency for several months. Intravenous urograms may be helpful in the explanation of obscure febrile reactions. Cystoscopy has no place in the routine care of the neurogenic bladder.

7. TREATMENT OF DECUBITUS ULCERS. Bed sores and decubitus ulcers are the late consequence of ischemic gangrene of the skin and subcutaneous tissue. They are preventable. Topical applications of antiseptic drugs and healing ointments have no demonstrable value.

a. Superficial cutaneous abrasions may be healed by the avoidance of pressure, frequent postural changes, and the maintenance of nutrition.

b. Deeper ulcerations should be treated by surgical excision of the necrotic slough with primary or delayed skin closure or skin grafting. Undermining of skin to facilitate closure, when feasible, is preferable to skin grafting. Systemic penicillin therapy and whole blood transfusions are legitimate adjuncts to this surgical program.

8. PHYSIOTHERAPY. The objective of physiotherapy is to maintain tissue vascularity and joint mobility until such time as physical reconditioning may be instituted. This is usually the period of spinal instability; that is, 6 weeks to 3 months for penetrating wounds of the cord, and 3 to 6 months for major vertebral fractures. Pain on attempted motion should be investigated by X-ray to identify periarticular calcification.

a. Massage and passive exercise help retain tissue turgor and joint motion.

b. Heat lamps and ultraviolet lamps are of questionable value.

c. Hot water tub treatments are not recommended. They are, in general, more debilitating than helpful.

9. PHYSICAL RECONDITIONING. An aggressive policy of physical reconditioning is the cornerstone of successful rehabilitation of paraplegic patients. Didactic instruction and personal supervision by a skilled and enthusiastic physical instructor are essential to the success of the program.

a. The objectives of physical reconditioning are—

(1) To maintain, as nearly as possible, the level of physical fitness present when disability was incurred.

(2) To promote recovery and restore function of weakened and affected muscles.

(3) To restore and actually increase the strength of the muscles of the shoulder girdle in anticipation of increased dependence upon the upper extremities during ambulatory convalescence.

(4) To instill self-confidence into the patient. Increased appetite, improved nutrition, and heightened morale contribute to a general sense of well-being.

b. There should be a definite administrative organization for the program:

(1) The *medical officer* should advise the physical reconditioning instructor and confer with him from time to time as to the progress of individual patients. No patient should be exercised before the medical officer has completed the diagnosis and noted the precautions to be observed. The absence of the protective pain mechanism dictates an initial restraint in prescribing exercises. After tolerance has been established, graded exercises are prescribed to the limit of ability consistent with common sense. (See TB MED 137, January 1945.)

(2) One *physical reconditioning instructor* should be assigned the responsibility of conducting the exercise program for paraplegic patients. Additional personnel, if needed, should be designated as assistants. A roster of patients with records of individual progress should be maintained. New patients require orientation as to the objectives and requirements of the program.

(3) The *patients* take the exercises in the position they are in at the selected time for calisthenics. Patients are encouraged to keep personal records of their progress, measurements being in terms of times and numbers of exercises or increase in range of motion. It has been found helpful to maintain competitive charts with weekly records of body weight, circumference of arms, and the number of the various exercises performed.

c. The *schedule of exercises* should provide for conducted and voluntary periods.

(1) Group exercises under supervision and instruction "by the numbers" should be held for a 30-minute period each day Monday through Friday.

(2) Patients should perform the group exercises "on their own" at a time announced by the ward nurse for a second period of 30 minutes each day Monday through Friday, twice daily on Saturdays and Sundays.

(3) Special exercises may be prescribed for voluntary performance at hourly intervals throughout the day. Pull-ups on a trapeze, dumb-bell exercises, and the like may be given in this fashion.

d. It has been demonstrated that the ambulatory phase of convalescence is dependent upon preliminary physical reconditioning. If this is neglected or ineffective, patients are unable to move freely, suffer from arthritic and radicular pains, and cannot tolerate even a wheel-chair existence.

10. AMBULATORY TREATMENT. The two greatest drawbacks to the establishment of an ambulatory regime are: persistence of the mass reflex; and persistence of atony of the urinary bladder. These complications require special consideration. (See pars. 11 and 12.)

a. The use of a wheel chair is possible for the great majority of patients as soon as there has been sufficient development of the arm and trunk muscles. Occupational or vocational therapy may be begun in earnest.

b. Attempts at walking should be instituted under the guidance of a consulting orthopedist. Use of the tripod training walker is a matter of election. Crutches, braces, and splints usually have to be fitted. Tendon transplants and joint fusions may be indicated. Flexor spasm is a neurosurgical problem. Each case should be treated in accordance with individual needs. In general, corrective procedures of this sort should be allocated to the final stages of convalescence.

c. Most patients retaining function of the upper extremities can be made ambulatory and may enjoy life within the limits of their intelligence. They can carry on ordinary daytime activities without urinary or fecal incontinence or having to evacuate the bladder oftener than every 3 hours. They can sleep through the night without involuntary soiling or having to get up. These objectives should be the visualized goals of every patient.

11. UROLOGIC COMPLICATIONS. Infections, calculi, and the persistently hypotonic bladder are the most frequent and serious urologic complications. Urinary retention from improper bladder drainage leads to back-pressure and stagnation of the urine as etiologic factors in many instances. Bacterial contamination of bladder urine is an inevitable accompaniment of tube or catheter drainage. Loss of retroperitoneal fat as part of the generalized nutritional depletion permits obstructive kinking of the ureters as they pass over the pelvic promontory. General demineralization of bone as part of the atrophy of disuse contributes to the excretory burden of the kidney. A broad concept of the etiologic factors is essential to successful management of urologic complications. Cystoscopic maneuvers through an infected bladder carry an excessive incidence of severe reactions. Observation cystoscopy of the urinary bladder, when indicated, may be performed through the cystostomy tract. X-ray and intravenous urography are the preferred diagnostic aids.

a. *Urinary tract infection* should be considered as a possible explanation of any obscure febrile reaction in a paraplegic patient.

(1) *Pyelonephritis* or *cortical abscesses* may be relatively "silent" except for fever and X-ray evidence of obstructive changes in the upper urinary tract. Treatment is frequently empirical. Systemic treatment with penicillin, sulfonamides, or both, is useful unless *B. proteus* or *B. pyocyaneus* are the only etiologic bacteria. A high urine volume should be maintained. Whole blood transfusions are necessary to prevent anemia.

(2) *Epididymitis* is readily recognized. It is chiefly a complication of urethral drainage. Removal of the catheter and institution of suprapubic drainage is reserved for persistent or repeated infection. Systemic chemotherapy and scrotal support suffice for the average case. The surgical drainage of pus is rarely necessary.

(3) *Periurethral abscess* may occur at the peno-scrotal angle. Early incision and drainage is the treatment of choice. If the abscess is large, it may be necessary to remove the urethral catheter and institute suprapubic drainage.

b. *Calculi*, once formed, present the same problems in treatment established for the

nonparalyzed patient. After indicated surgical procedures, a temporary loss of bladder tone should be anticipated.

c. The persistently atonic or hypotonic bladder is largely an unsolved problem. Tidal drainage is indicated for all or most of the time. During ambulatory periods, the catheter may be allowed to drain in a urinal. The purpose of continued tidal drainage is to prevent ultimate fibrosis and contracture of the bladder wall.

12. NEUROSURGICAL COMPLICATIONS. Pain, progressive paralysis, and mass reflexes associated with intractable flexor spasm and ultimately flexor contractures are the most common neurosurgical complications. It is important to differentiate nonspecific and arthritic pains from true neurologic difficulties. The proper management of neurosurgical complications may tax the judgment and ingenuity of the most skilled specialist. The decision for operative intervention should entail wide consultation.

a. Excessive proliferation of bone at the fracture site may be responsible for *progressive paralysis or pain*. Decompression is helpful.

b. Retained foreign bodies or displaced bone fragments in the cauda equina should be removed. Purely exploratory procedures for the identification of pathologic neural change are condemned.

c. Radicular pain due to pressure on the nerve roots at the site of injury may require appropriate rhizotomy.

d. Certain patients complain of intense burning pain in completely paralyzed extremities. If the lesion is in the cervico-dorsal region of the spine, anterolateral cordotomy may be necessary for relief. If the lesion is at the dorsolumbar junction or below, the burning pain may evidence a true causalgia due to injury of the cauda equina and amenable to sympathectomy. Paravertebral novocain block of the lumbar sympathetic ganglia will indicate the cases in which sympathectomy is warranted.

e. Massed reflexes, or reflex motor spasm in response to minimal stimuli, may be so severe as to handicap the entire program of rehabilitation. They may be associated with the involuntary discharge of urine and feces. Many patients show this massed motor activity during the convalescent phase. Massed reflexes are not necessarily an indication of complete section of the cord. As purely spinal reflexes, they tend to become exhausted with the passage of time with reduction of power and excitability. Appropriate rhizotomy will abolish the reflex but operation is justified only after all hope of spontaneous recovery has been abandoned.

13. DISPOSITION OF PATIENTS. Perhaps in no other group of patients is successful rehabilitation so dependent upon a continuous and integrated program of convalescence. Changes of environment and professional assistance are damaging to the loyalty, morale, and self-confidence of patients. The road to maximal recovery is long and arduous, beset with many discouragements. There is a high moral obligation upon medical officers to provide continuous and uninterrupted treatment to the point of maximal rehabilitation for these soldiers. Disposition by certificate of disability, discharge, or retirement to home or veterans facility will be accomplished only after maximal hospital benefit has been obtained.

[AG 300.5 (16 May 45)]

BY ORDER OF THE SECRETARY OF WAR:

OFFICIAL:

J. A. ULIO,
Major General,
The Adjutant General.

G. C. MARSHALL,
Chief of Staff.

DISTRIBUTION:

AAF (5); AGF (5); ASF (2); T of Opn (25); Dept (5); Base Comd (5); Island Comd (5); Arm & Sv Bd (1); Def Comd (5); S Div ASF (1); Tech Sv (2) except SGO; SvC (10); GH (Named) (60); RH (40); SH (Named) (40); Gen Disp (ZI) (10); Gen & Sp Sv Sch (5); USMA (2); ASTU (1); ROTC (2); Tng C (2) except Tng C 8 (60); Repl Tng C (2); Ind Sta (10); Sv C Lab (5); A (5); CHQ (5); D (55); T/O & E 8-510S (35); 8-550 (60); 8-550S (45); 8-560 (40); 8-580 (40); 8-581 (30); 8-590 (20); 10-95 (7); One (1) copy to each of the following: T/O & E 3-25; 4-45; 4-145; 4-232; 5-55; 5-72; 5-95; 5-275; 6-35; 6-55; 6-65; 6-75; 6-95; 6-175; 6-325; 6-355; 6-365; 6-395; 7-85; 9-12; 11-25; 17-55; 17-125; 18-25; 19-35; 20-42; Two (2) copies to each of the following: T/O & E 2-22; 4-152; 4-260-1; 5-386; 5-535S; 6-12; 6-45; 8-22; 8-26; 8-520; 9-35; 9-76; 10-22; 10-165; 10-217; 11-15; 17-15; 18-10-1; 18-35; 19-55; 20-46; 44-15; 44-25; 44-75; 44-115; 44-125; 44-225S, 44-315; 55-120-1; Three (3) copies to each of the following: T/O & E 5-192; 7-95; 8-27; 10-45; 10-175; 17-115; 44-135; 44-325; 55-110-1; Five (5) copies to each of the following: T/O & E 5-21; 8-534; 8-572S; 8-780; 8-790; Six (6) copies to each of the following: T/O & E 5-21; 10-125; Ten (10) copies to each of the following: T/O & E 8-28; 8-595T; 8-750; 8-760; Fifteen (15) copies to each of the following: 8-150; 8-537T; 8-591T.

Refer to FM 21-6 for explanation of distribution formula.

APPENDIX C

Routine Procedure for Transverse Myelitis Cases¹

I. ORDERS ON ALL NEW ADMISSIONS

1. Complete blood count.
2. Blood chemistry: (to include NPN, urea, creatinin, phosphorus, calcium, protein, A/G ratio, hematocrit.)
3. Kahn.
4. Urinalysis.
5. Urine culture.
6. Neurological consultation. (New injury cases.)
7. Orthopedic consultation. (New injury cases.)
8. X-ray of chest.
9. X-ray of spine. (As indicated by the ward surgeon.)
10. KUB X-ray.
11. Body weight.

II. UROLOGICAL CARE

1. Tidal drainage to be applied only in cases where no reflux occurs. (Tested by cystogram.)
2. On the bedside table of each patient who has any type of tube, there will be a jar of alcohol sponges. The patient will be instructed to cleanse the rubber tube and glass tube after disuniting and before uniting them.
3. On each patient's bedside table there will be an alcohol jar of submerged finger cuts. The patient will be instructed to protect the disunited system between the drainage and catheter, and he will be instructed to protect the end of the catheter or end of the glass connecting tube after he has disunited them so that he may leave his bed.
4. All glass tubing on tidal drainages or direct drainages will be kept clean. This will be the duty of the GU man assigned to the respective ward. The tidal drainage will be changed once each week. Catheters will be changed once a week in suprapubic cases, once a week in intraurethral cases without complications, and every 48 hours in cases of epididymitis with intraurethral catheter.
5. Irrigation fluid will be routinely: Acetic acid one-quarter percent, or boric acid 2 percent, or sulfanilamide solution 1:1000. Solution G, G-2, or M will be used only if indicated by the ward surgeon.
6. Despite tidal drainage, all catheter cases will be irrigated by hand syringe twice daily. Solution G will be used in cases who have a tendency to form calculi around the catheter, or in those cases who have had real bladder or kidney stones.
7. Sterile bottles will be used for urinary drainage.
8. In all bed patient cases, intake and output will be registered daily.
9. The intake of each patient will be around 3,000 cc. or more daily.
10. A pH determination by nitrozone paper should be done once a week on each patient, and a weekly report submitted to the ward surgeon. Care should be exercised that no irrigation fluid is being tested.
11. Urinalyses will be taken weekly on all patients. Urinalyses will be taken more often if indicated by the ward surgeon. Urine cultures will be taken once in 6 to 8 weeks.

¹The very valuable material in this appendix, which describes the routine employed in the paraplegic center at Hammond General Hospital, Modesto, Calif., during World War II, was prepared by Capt. (later Maj.) Ernest Bors, MC. Captain Bors was one of the pioneers in the development of the program for the care and rehabilitation of paraplegic patients. Coming to his duties after training as a urologist, he proved one of the most competent and dedicated of all medical officers in developing a specific regimen of care for the rehabilitation of paraplegics. He has made many original contributions in this field, in which he is still actively engaged in the Veterans' Administration hospital system.—B. W. and R. G. S.

12. Concentration and dilution tests will be taken on all patients once in 3 months.
13. KUB pictures will be taken routinely once in 3 months, providing patients have never shown calculi of the kidneys or bladder.
14. IV pyelograms will be taken once in 6 months provided there has never been any calculosis.
15. In cases of calculosis, KUB's and/or IV pyelograms and/or retrograde pyelograms will be done once in 4 weeks.
16. A weekly report will be submitted by the GU man to the ward surgeon, listing cases as suprapubic, intraurethral, no catheter, dribbling, or clamping off. The latter refers to suprapubic cases which are in the process of clamping off.
17. In cases without catheter, the following procedures will be observed by the GU man and will appear on his weekly report:
 - (a) Urine clear, residual 2 to 3 ounces, test residual every 2 weeks.
 - (b) Urine hazy, no residual, test residual every 2 weeks.
 - (c) Urine hazy, residual 2 to 3 ounces, test residual every week.
 - (d) Urine hazy, residual 3 to 8 ounces, test residual twice a week.Each testing for residual is to be followed by irrigation with boric acid solution, 2 percent.
18. The GU man is to be instructed to take the specimen for urine culture according to the following rules:
 - (a) If patient voids normally, he is to void in two or three test tubes, and last tube to be for sterile culture.
 - (b) If the patient has a suprapubic or indwelling catheter, the catheter is to be discontinued for a sufficient time to rule out irrigation fluid.
 - (c) If patient has an automatic bladder, catheterized specimen will be obtained.
19. In cases with suprapubic tubes, it is permissible to start clamping off for 1 hour at first, and later for 3 hours if patient has observed that urine is escaping freely through the urethra. (This is usually first observed during bowel movements.)
20. After removal of the suprapubic catheter, attempt should be made to apply a butterfly to the suprapubic sinus without insertion of a urethral catheter.
21. The patient should be admonished to void every hour on the hour at first, and later every 2 hours, if automatic bladder has developed.
22. If the suprapubic sinus does not close within 10 to 15 days, intraurethral catheter and fulguration of the suprapubic sinus are indicated.
23. If the above measures fail, the suprapubic sinus will be closed surgically.
24. Sphincterometric and cystometric examinations should be done on patients where no automaticity of the bladder has occurred, at approximately 6- to 8-week intervals. According to the outcome of the sphincterometric and cystometric examinations, therapy will be devised with a trial given to Furmethide in atonic or hypotonic bladders, one-half tablet twice a day. Trasentine should be given three times a day, two tablets, in hypertonic bladders; pudendal nerve blocks in cases of good intravesical tone but simultaneous hyperactivity of sphincteric systems, tested by sphincterometric examinations and verified by a strong bulbocavernosus reflex. The latter should be tested routinely in each patient. (Execution: rectal examination of patient; squeezing of glands produces contraction of the anal sphincter.) Sympathetic block to be tried in cases with hypertonicity of internal sphincter only.
25. Oral urinary antiseptics will be:
 - (a) Calcium mandelate, three times a day, two tablets, for at least 10 days.
 - (b) Sulfonamides: sulfadiazine routine: first day, 1 gram sulfadiazine plus 20 grains of soda bicarbonate, q4h. Following this, 4 x 24 hours, one-half gram sulfadiazine plus 10 grains soda bicarbonate q4h. During this routine, urinalysis should be done every second day in order to check for sulfa crystals. WBC in blood to be determined, with hemoglobin, every other day. Sulfa level will be taken after the first 48 hours.

Forcing of fluids will be strictly observed in these cases, with a minimum intake of 3,000 cc. per day.

26. Sulfadiazine intravenously will be given as an intravenous Murphy drip, 5 grams (20-cc. ampules) mixed with 80 cc. of triply distilled sterile water, slowly dripping (1 hour). The same precautionary measures will be taken as observed during oral sulfonamide therapy.

27. Penicillin routine will be 25,000 units every 3 hours.

28. From the WBC count in the urine and the bacteriological report, the ward surgeon should evaluate which therapy he considers to be suitable.

29. Streptomycin therapy should be used as follows:

(a) In cases without residual, but with persistent infection without calculosis, in order to clear up the infection. (Susceptibility to streptomycin must be demonstrated prior to therapy.)

(b) Vitally indicated in acutely, seriously ill patients in the presence of calculosis, after drainage has been established and blockage bypassed.

30. If WBC's in the urine persist in high numbers, or if slight macroscopic hemorrhage occurs, or if RBC's persist in sediment, cystoscopy appears indicated.

III. BOWEL REGULATION

Bowel regulation will be best achieved when the patient is brought into the proper position (Fowler's position) on either a gurney, if the patient is seriously ill, or the toilet seat, or directly on the latrine toilet bowl. In addition, impaction should be prevented by not letting the fecal matter dry out. Overdistention by too large quantities of enema fluid should be prevented. The patient should eventually be taught to press with flatly applied palms to substitute for the absent abdominal muscles.

1. Routine application of mineral oil, one-half to 2 oz., at bedtime with or without the addition of bulk-forming Imbicoll, 1 to 2 teaspoons.

2. A weekly report is to be given by the ward attendant in charge of bowel evacuation, as to the efficiency of the above mentioned routine. He is to report cases of impaction and of loose bowel movements, which eventually might lead to involuntaries. This report should be submitted through the ward nurse to the ward surgeon who will take corrective measures.

3. Cathartics such as licorice powder or cascara will not be used routinely except with the consent of the ward surgeon, and in specially selected cases, as in preparation for KUB pictures or IV pyelograms.

4. It is permissible that the patient use a rubber gloved finger to initiate defecation while on the toilet in the latrine.

5. It is not permissible that the patient dig out bowels with rubber gloved finger; he should, instead, report the condition present to the ward nurse or doctor.

6. If the finger does not suffice to initiate bowel movements, glycerine suppositories, one or two, should be introduced by the patient.

7. If glycerine suppositories do not suffice, small enemas consisting of 90 cc. water, 30 cc. glycerine and 30 cc. mineral oil should be used. The patient is to be taught to apply these enemas himself, if both of his upper extremities are not impaired.

8. If this procedure does not suffice, then the ward doctor should be informed before further steps are taken.

9. It is highly desirable that the ward surgeon and the ward nurses instruct patients on their wards upon the necessity of becoming independent of assistance by attendants for their bowel habits.

IV. DIET

1. The diet may be a mixed diet in the average case.

2. Acid ash diet is desirable, in order to change the pH determination of the urine. The patient is to be instructed as to the detrimental effect of any addition to this diet purchased in the PX, because of lack of medical control.

3. Use of vitamins A, B, and C:

- (a) Vitamin A should be used in all cases of calculosis and recurrent calculosis.
- (b) Vitamin B should alternate with vitamin C every other week.
- (c) Vitamin C should be chiefly used in all inflammatory exacerbations, but it is desirable that it be given in large doses without any other vitamins.

V. BLOOD ROUTINE

1. A WBC count and hemoglobin should be done routinely every 6 weeks. Complete blood count to be taken only if pathology is encountered by the aforementioned method, or in case of acute illness.
2. NPN should be done routinely once in 6 weeks unless otherwise indicated by the ward surgeon because of acute illness.
3. Under emergency conditions, all the blood chemical analyses should be done which appear justified by the ward surgeon.

VI. BEDSORE ROUTINE

1. Culture of bed sore to be taken prior to closure or grafting.
2. Photographs with ruler and name card in place to be taken before closure or grafting (or an admission of new patients).
3. Protein level with A/G ratio to be done preoperatively.
4. Wet dressings, preoperatively, are to start routinely, 3 days prior to skin graft or closure. (Dakin, Domeboro, or saline.)
5. Routine sulfa and penicillin to be started 24 hours prior to operation if so indicated by the culture.
6. Postoperatively, patient is to be kept off the operative region, and in selected cases he is to be put on a Stryker frame for from 4 to 5 days. Dressings will be changed by the operator or ward surgeon if he has been designated to do so.
7. Following buried type of epidermis graft, dressing to be changed daily. Domebromo solution wet dressings to be applied for the first week, by the ward surgeon.
8. When the bed sore closure or graft has become healed, another photograph will be taken.
9. General outline for therapy: Mummification and dry crust will be handled differently from moist, gangrenous sore:
 - (a) In mummification, demarcation should take place before the crust is attacked. Exposure to air and dry protection for the crust is desirable. In cases where mummification is accompanied by a strong inflammatory reaction, with reddening and infiltration of the margins surrounding the crust, softening of the crust and consequent debridement is most quickly achieved by local application of cod liver oil ointment.
 - (b) Moist, gangrenous sore to be debrided at once. Permissible treatment according to the judgment of the ward surgeon:
 - (1) Sulfa and sugar, and exposure to air.
 - (2) Dakin wet dressings.
 - (3) Domeboro or acetic acid wet dressings.
 - (4) Saline wet dressings.
 - (5) Local penicillin jelly or ointment or wet dressing (1,000 units/1 cc.).
 - (c) If the wound is clean, zinc diaphoresis is permissible. Bathing is permissible if concurrent induration and inflammatory condition has subsided. Exposure to air and sunshine is permissible and recommended. Exposure to ultraviolet lamp is permissible in combination with local application of cod liver oil ointment; contact ultraviolet lamp is preferable in this procedure.
10. Ointments recommended for epithelialization are:
 - (a) Scarlet Red ointment.
 - (b) Silver Peruvian ointment (1 : 10 : 100, 70 percent cod liver oil as base).
 - (c) Cod liver oil ointment, 70 percent.
 - (d) Desitin ointment.

11. Bedsores are not a contraindication to walking unless recently operated. Many sores will improve if the patient does walk.

12. Prevention of bedsores:

- (a) Routine turning of patients every 2 hours.
- (b) Routine protective treatment of the skin by alcohol rubs.
- (c) Patient to be kept completely dry at all times.
- (d) Use of Stryker frames in recent injuries will also contribute to prevention

of sores.

- (e) Prevention of pressure by application of rubber rings and doughnut pads.

13. Where superficial pressure or excoriation appears, paint with tincture of benzoin and expose to air.

14. Recurrent decubitus ulcers are to be considered a symptom indicating that the patient is not making wanted progress. He should be checked for urinary complications, malaria, bowel disturbance, or other sources.

15. Persistent decubitus ulcers at ischial bone or trochanteric regions should be evaluated as to secondary osteomyelitis activity, by X-ray of the respective region.

VII. SPASTICITY

1. Patient to be checked for interference with walking such as adductor or hamstring spasms.

2. If interference with walking by scissoring is obvious, obturator neurectomy and severing of adductor muscles is indicated. Procedure should not be carried out prior to 12 months following injury unless severe progress of spasm has been observed.

3. Routine application of curare intramuscularly, 0.05 milligram per pound weight of patient. The course will include three injections of 3 successive days followed by a 3-day interval and repeated twice. Change of treatment or statement of efficiency will not be considered until the above complete routine has been followed.

4. A report on all curare patients will be submitted to the ward surgeon at the conclusion of the first course.

5. During application of curare, a resuscitator will be on the ward, and prostigmine, 1 : 4000, 1 cc., will be ready for intravenous injection, if indicated.

6. Curare records will be kept by the physiotherapists.

7. If curare has been found inefficient, the doses can be stepped up to 50 percent for the next course and, if no results are obtained, it may be further increased doubly for the third course.

8. Curare in beeswax will be requested because of its reported higher efficiency.

9. In connection with curare, all patients will be weighed once in 6 weeks, and a record kept of their weight.

10. Spasticity will be counteracted by the physiotherapists through gentle stretching, carefully avoiding all spinal reflexes, and also by application of the Hubbard tank treatment.

11. Heat treatment is permissible for relaxation and will be used in selected cases as indicated.

12. Grading in curare therapy is done according to:

- (a) Spontaneous spinal or mass reflexes: Grade I.
- (b) Mass reflexes induced by touching lightly with swab: Grade II.
- (c) Mass reflexes induced when pricked by pin or sharp stick: Grade III.
- (d) Mass reflexes induced when struck a sharp tap: Grade IV.

VIII. PAIN (so-called root pain)

1. Root pains occur on the trunk, bilaterally in extremities, or unilaterally in extremities.

2. Root pains might be caused by another underlying pathology such as kidney calculi which therefore should be ruled out prior to therapy.

3. In order to alleviate root pains, venom therapy is permissible: one-half cc. twice a day to start, eventually increasing during the first week to 1 cc. twice a day.

4. Causalgia with hyperhidrosis is to be differentiated from conditions encountered in lower extremities where the temperature is raised and sweating is absent.

5. Causalgia might respond to Depropanex, 2 cc. intramuscularly, four times a day, or to sympathetic block. If so, and if it does not level off by itself, the case is amenable to sympathectomy.

6. If the dry, hot condition exists, the case might be treated with gynergen, one-quarter to 1 cc. intramuscularly per day for 3 to 4 days. If the slightest paresthesia occurs or numbness in the fingertips, therapy must be discontinued at once.

IX. CLASSIFICATION OF PATIENTS

Three classes of patients are differentiated as shown on the following chart:

CLASS I
WALKING AND INDEPENDENT PATIENTS

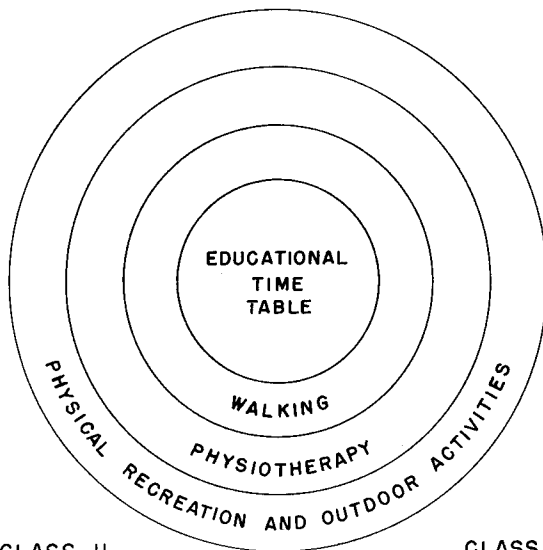

CLASS II
WHEELCHAIR PATIENTS
PREPARATION FOR WALKING

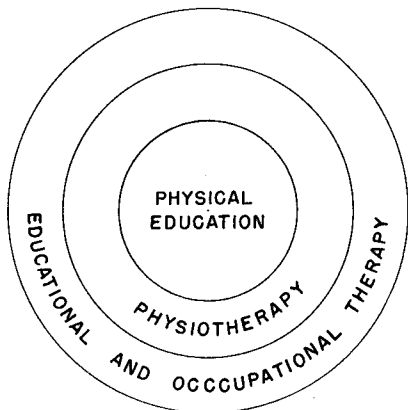

CLASS III
BED PATIENTS

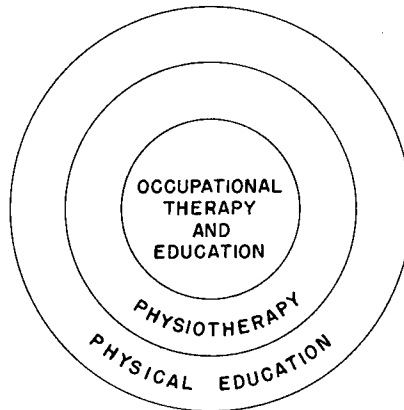

Class I.—Walking and independent patients: All activity is focused around educational and vocational timetable. Walking, physiotherapy, physical recreation, and outdoor activities take second and third place.

Class II.—Wheelchair patients (preparation for walking): All activities will focus around physical education; then follows physiotherapy and eventually educational and occupational therapy.

Class III.—Bed patients: All activities will focus around occupational therapy, education, entertainment, symptomatic physiotherapy, and finally physical education in the lightest form will be subordinated.

X. SURVEYS

Surveys as attached are to be completed on each patient, and kept up to date with each new complication arising:

1. General information (to be kept as a roster on each ward).
2. Desirable final bladder condition.
3. Incidence of calculosis.
4. Sexual condition.
5. Gynecomastia.

* * * * *

XI. WALKING

1. Prior to walking, a patient's torso and arm musculature must be prepared by regular physical exercise, outlines for which are on the files of the Physical Reconditioning Branch.

2. Before a patient walks, he must be up in a wheelchair daily for at least 2 weeks.

3. Fainting can be avoided in cases with paralyzed abdominal musculature, by abdominal binders prior to getting up, or by adrenalin in oil, 1 cc. intramuscularly. This will be given one-half hour prior to getting up.

4. Adrenalin in oil is indicated only when a severe drop in blood pressure has been found between the supine and erect position.

Walking School Procedure

Parallel bars:

Before a patient begins walking procedure, he should be up in a wheelchair for at least 2 weeks, and his musculature should have been prepared to support him on the parallel bars, by regular physical exercises.

1. Balance exercises: Patient is put in braces and placed between parallel bars, his feet slightly apart, side-straddle position, with both hands on the bars. He is then to release one hand after the other, keeping his balance. Once he has mastered this, he is to release both hands from the bars, still maintaining his balance. In all these exercises, a slight forward leaning position is desirable; however, the patient will have to find out, according to the level of his lesion, where his point of gravity lies.

2. Leg-swinging exercises: With both hands on the parallel bars, the patient is requested to lift one leg after the other, and to swing his leg forward and backward. The patient will increase the number of swings with practice.

3. Forward-stepping exercises: Patient is placed in a slight forward-leaning position, similar to the tripod position, on crutches, with his legs approximately 4 to 5 inches apart. He is then instructed to use his right hand and left in the following manner: Patient releases grasp of right hand from the bar and places it approximately 3 inches forward. By leaning on outstretched right arm and pushing against outstretched left arm, with a rotating motion from the hips, he pushes the left leg forward. After patient has done this, taking a step of about 2 to 3 inches, he repeats the same procedure, using the left arm and right leg.

4. Backward-stepping exercises: These exercises are done in the same manner as the forward-stepping exercises, using opposite arm and leg, with even shorter steps.

5. Sidestepping exercises: Patient faces the bar, side-straddle position, legs 3 to 4 inches apart. Sidestepping to the right, he advances his right arms 3 to 4 inches to the right, and pulls his left leg to his right leg, and then advances the right leg 3 to 4 inches. The maneuver is then repeated, grasping in a new position.

Caution:

Patient should be closely watched during his first exercises to prevent his fainting, as far as possible. Pulse rate should be controlled and sweating watched. Patient should not exercise to the point of fatigue.

Crutches:

Only after a patient has become experienced and confident on the parallel bars, with or without a transitional period on the walker, should he be put on crutches. During the crutch exercises, the attendant should stand behind the patient, always ready to grab him, and encouraging him to fall forward instead of backward.

1. Tripod position: Patient leans forward in front position without hanging his axilla in the crutches. By holding the crutch handles in a firm grasp with outstretched elbow, patient stands in a side-straddle position with feet 3 inches apart, and learns to keep his balance.

2. Swinging exercises: Crutches will be placed apart, permitting a firm grip, and then patient is instructed to sway his body to the left and right, supporting himself chiefly on the left or right crutch. Once he has finished the swaying exercises and is confident to perform them on both crutches, he will lift his right crutch while swaying to the left side, etc.

3. Equilibrium exercises: After patient has completed the above exercise, he will take a side-straddle position with feet approximately 12 inches apart. He will then attempt to shift his equilibrium slowly, relying chiefly upon one crutch. This crutch will eventually form a triangle; in the apex of the triangle, crutch will be in front of patient and the base of the triangle will be formed by the two feet. This will enable the patient to stand slightly leaning forward on one crutch, with the other crutch lifted.

Crutches (walking positions)

1. *Four-point step walk:* Tripod position: right crutch, left leg, left crutch, right leg. *Execution:* Right crutch placed 2 to 3 inches forward to start with. Equilibrium shifted to right leg at the same time the outstretched left arm pushes away from the left crutch, permitting rotating motion forward of left leg. Same procedure is repeated with left crutch and right leg. During this procedure the patient is encouraged to support his weight entirely on the supporting standing leg, thereby permitting the opposite swaying leg to be carried without touching the floor, through a hip-lifting motion originating in the shoulder of the side from which the leg is swung.

2. *Quick four-point or ski-walk:* This is basically the same type of step as described under "four-point walk" except that this is executed in a quick manner which permits the motion of right crutch, left leg (and vice versa) to occur almost simultaneously, and also permits a sliding walk as used on skis.

3. *Side, backstepping, and turning around exercises* should be taught similar to those performed and executed on the parallel bars.

4. *Swing-to walk:* This exercise is advocated for patients with a lesion of D-10 or higher (i.e., from the line of the umbilicus or higher level). The swing-to walk consists of tripod basic position. Then the patient is instructed to move both crutches forward, which in the beginning he will probably accomplish by moving each crutch individually and not both at the same time. He then pulls his legs forward 2 to 3 inches until he gets back into a tripod position. This maneuver repeats itself, thus enhancing locomotion.

5. *Swing-through walk:* Same procedure as swing-to walk except that the legs will be swung to a position exceeding the tripod position whereby patient will always have

to lean forward in order to prevent dropping backward. This will have to be done rather quickly in order to maintain balance.

Walker exercises:

1. The walker may be utilized by those patients who wish to use it as a transitional stage between bar exercises and crutch exercises. High-level lesion cases are not encouraged to use the walker unless they so desire in order to do the hop-walk, rather than individual stepping.

2. The execution is as follows: Patient in walker faces the attendant, and takes the tripod position. The walker is then swung to the left, whereby the patient shifts his equilibrium to the left, standing on the left leg. He then pushes his body away from the right side by stretching his right arm and pushing it against the handle of the walker, thus permitting the right leg to swing forward. The maneuver is then executed to the right side.

Sit down exercises:

1. Patient walks to chair on crutches, turns sideways with leg nearest chair slightly forward and leaning against the chair. Patient lays down crutch nearest to chair, grasps chair arm, unlocks brace nearest chair, regrasps chair arm, using remaining crutch as support, rolls backward and into chair seat.

Stair-stepping exercises:

1. Steps of the parallel bars may be utilized to instruct the patient in stepping upstairs and downstairs. Downstair stepping preferably executed in a backward position.

2. Curb stepping could be taught by removing one of the parallel bars and teaching the patient to step up on side of bar platform.

3. Stair-stepping exercises will be executed by using the shallow steps first, one hand on the banister and the other hand on the crutch. Steep steps to be attempted only when patient has graduated from the shallow steps with confidence.

Uneven ground and ramp exercises:

1. Patients will first try shallow ramps and progress to steep ramps, when he has become proficient at the other walking exercises. Eventually uneven ground exercises on the lawn should be executed routinely.

XII. WORKING SCHEDULE

1. The ward surgeon will check at least once a week on all general surgical questions such as bedsores, gynecomastia, etc.

2. The ward surgeon will check on all urological problems once each week. Use of the abbreviated GU progress sheet form is recommended.

3. All problems referable to bowel regulation will be checked every 2 weeks, and recorded on the attached bowel movement progress form.

4. The ward surgeon will check on the neurological condition once each week, using the attached form as progress notes.

5. The ward surgeon will observe patients in their walking progress each week, and check his bracing problems, etc.

6. Each Monday, all X-rays taken the previous week will be on hand on the ward and will be shown to the conference of all ward surgeons and the chief of the paraplegic service. This will be followed by rounds on that particular ward, where all problems and necessary consultations or operative procedures will be discussed. It is contemplated that, in order to make a thorough study, 1 ward of 48 patients should be seen that day.

7. It is desirable that all patients of the service who can walk be seen once in 3 weeks by the chief of the paraplegic service.

* * * * *

APPENDIX D

Battle Wounds and Battle Injuries of the Spinal Cord and Vertebrae

The statistical data presented in tables 1 and 2 were prepared by the Medical Statistics Division, Office of the Surgeon General.

The term "admission," as used in these tables, refers to cases in which a battle wound or a battle injury of the specified site was reported as the primary cause of admission to hospital or quarters. With respect to multiple wounds recorded on admission, only one, the more serious, would have been recorded as the admission diagnosis. Data pertaining to patients who incurred spinal injuries but were admitted to treatment primarily for wounds or injuries of other sites are not available. With respect to KIA (killed in action) data, the anatomical region indicated is that associated with the primary cause of death. The variables, causative agent, nature of traumatism, and anatomical location pertain to the primary diagnosis for admissions and CRO (carded for record only) cases and to the principal cause of death for the KIA.

TABLE 1.—Battle wounds and battle injuries of the spinal cord and vertebrae in the U.S. Army, by causative agent, combined years 1942, 1943, and 1945

[Preliminary data based on tabulations of individual medical records]

Causative agent	KIA ¹	Nonfatal CRO cases ²	Admissions ³	Deaths among those admitted ⁴	Case fatality ratio
	Number	Number	Number	Number	Percent
Bomb and bomb fragments.....	3	2	69	3	4.3
Shell, shell fragment, and flak.....	30	15	1,408	157	11.2
Bullet, machinegun, rifle, etc.....	36	750	153	20.4
Landmine, boobytrap.....	7	4	189	10	5.3
Grenade and grenade fragments.....	3	1	32	3	9.4
Explosion of ammunition, weapon, etc.....	5	1	51	1	2.0
Firearms, mechanism or effects of discharge of.....	1	1	8
Aircraft, excluding aircraft weapons.....	12	1	130	3	2.3
Parachute jump.....	1	11	123
Boat sinking and accident.....	20
Tank, tractor, caisson.....	3	46
Motor vehicle, passenger and cargo.....	1	1	49
Vehicle, other and unspecified.....	9
Cutting or piercing instruments.....	4	1	25.0
Fall or jump, twisting, turning, listing, slipping, etc.....	1	412
Other and unspecified.....	5	3	126	6	4.8
Total.....	107	41	3,426	337	9.8

¹ KIA for whom a wound or injury of the spinal cord and vertebrae was reported as the primary cause of death. The number of KIA cases is markedly affected by the lack of detail in describing the anatomical location. This accounts for the relatively small number of KIA cases shown.

² CRO cases with a wound or injury of the spinal cord and vertebrae as the primary diagnosis.

³ Due to the wounds or injuries of the spinal cord and vertebrae.

⁴ Consists of all cases which ended in death, not necessarily due to a wound or injury of the spinal cord and vertebrae nor necessarily occurring during the years indicated.

NOTE.—The low case fatality ratios are probably due to the relatively minor nature of many of the cases which reached medical treatment facilities; many serious cases are killed instantly or die before arriving at a treatment facility.

TABLE 2.—*Admissions for battle wounds and battle injuries of the spinal cord and vertebrae, by location of traumatism, U.S. Army, 1942-43*

[Preliminary data based on tabulations of individual medical records]

Anatomical location	Nonfatal CRO cases	Admis- sions	Deaths among those ad- mitted ¹
	<i>Number</i>	<i>Number</i>	<i>Number</i>
Spinal cord.....		16	2
Vertebrae.....	19	594	31
Vertebral joints.....	4	68	-----
Total.....	23	678	33

¹ Not necessarily due to the wound or injury causing admission nor necessarily occurring during 1942-43.

APPENDIX E

Peripheral Nerve Injury Study (All Nerves)¹

NATURE OF THE DATA

The present study of peripheral nerve injuries is based on 6,336 individuals. Of these, 5,748, or slightly over 90 percent, showed only 1 nerve injury on which surgery was performed; 588, or about 10 percent, were reported as having been operated on for two or more nerve injuries.

The total number of nerves on which reports were received was 7,050. The ulnar was by far the most frequent nerve encountered, accounting for almost one-third of the total number of injuries. Next in order of frequency of occurrence were the median (with 19.5 percent of the total number of injuries), the sciatic (16.9 percent of the total), and the radial (14.1 percent of the total).

Throughout the entire study, the reports of these 7,050 nerve injuries have been divided into two categories:

1. OS (oversea) cases: Those cases on which the first report attempt at definitive treatment was performed overseas.
2. ZI (Zone of Interior) cases: Those cases on which the first reported attempt at definitive treatment was performed in the Zone of Interior.

On the basis of this division, the 7,050 nerve injuries were broken down into 1,390 OS cases (19.7 percent of total) and 5,660 ZI cases (80.3 percent of total).

Graft procedure as the original definitive treatment was used in only 1 percent of the total number of injuries. End-to-end anastomosis was performed as initial treatment on the remainder.

The total number of operations performed on these 7,050 nerves was 7,327.

¹ This analysis was prepared by the Medical Statistics Division, Office of the Surgeon General, and submitted to the Historical Unit, U.S. Army Medical Service, on 22 August 1956. The data were derived from material in the World War II Peripheral Nerve Registry from the date of the Registry's establishment up to the date of 1 November 1945.

TABLE 1.—Involved nerve and type of operative procedure (total cases)

Nerve involved	End-to-end anastomosis as original definitive procedure				Graft as original definitive procedure	Total cases	
	Primary		Other	Total		Actual	Percent
	No previous bulb suture	With previous bulb suture					
Brachial plexus.....	132		6	138	1	139	2.0
Median.....	1,240	63	59	1,362	14	1,376	19.5
Ulnar.....	2,095	63	90	2,248	13	2,261	32.1
Radial.....	904	48	33	985	12	997	14.1
Musculocutaneous.....	81	3	3	87		37	1.2
Digital.....	28			28	1	29	.4
Sciatic.....	1,101	36	49	1,186	5	1,191	16.9
Tibial.....	219	12	11	242	10	252	3.6
Peroneal.....	520	11	26	557	1	558	7.9
Femoral.....	19	1	1	21		21	.3
Facial.....	17			17	3	25	.4
All others.....	106	1	5	112	2	114	1.6
Total nerve injuries.....	6,462	238	³ 283	6,983	67	7,050	100.0

¹ Includes antebrachial cutaneous (49), sural (34), axillary (20), brachial cutaneous (3), spinal accessory (3), plantar (3).

² Includes axillary (1), cauda equina (1).

³ Includes cases with—

Secondary as first report received.....	77
Primary after graft as first report received.....	4
Only bulb suture report received.....	76
Primary, etc., section reported as "unknown".....	126

TABLE 1(a).--Involved nerve and type of operative procedure, OS and ZI

Nerve involved	End-to-end anastomosis as original definitive procedure								Graft as original definitive procedure		Total cases			
	Primary				Other		Total				Actual		Percent	
	No previous bulb suture		With previous bulb suture											
	OS	ZI	OS	ZI	OS	ZI	OS	ZI	OS	ZI	OS	ZI		
Brachial plexus.....	16	116			4	2	20	118		1	20	119	0.3	1.7
Median.....	223	1,017	4	59	26	33	253	1,109		14	253	1,123	3.6	15.9
Ulnar.....	394	1,701	7	56	40	50	441	1,807	2	11	443	1,818	6.3	25.8
Radial.....	178	726	5	43	12	21	195	790	1	11	196	801	2.8	11.3
Musculocutaneous.....	12	69	1	2	2	1	15	72			15	72	.2	1.0
Digital.....	1	27					1	27	1		2	27		.4
Sciatic.....	238	863	4	32	24	25	266	920	1	4	267	924	3.8	13.1
Tibial.....	34	185		12	2	9	36	206	1	9	37	215	.5	3.1
Peroneal.....	113	407		11	17	9	130	427		1	130	428	1.8	6.1
Femoral.....	3	16	1			1	4	17			4	17	.1	.2
Facial.....	3	14					3	14	4	4	7	18	.1	.3
All others.....	13	93		1	3	2	116	296		2	16	98	.2	1.4
Total nerve injuries.....	1,228	5,234	22	216	130	153	1,380	5,603	10	57	1,390	5,660	19.7	80.3

¹ Includes antebrachial cutaneous (11), sural (2), axillary (1), brachial cutaneous (1), plantar (1).
² Includes antebrachial cutaneous (38), sural (32), axillary (19), brachial cutaneous (2), spinal accessory (3), plantar (2).
³ Includes cases with—

	OS	ZI
Secondary as first report received.....	5	72
Primary after graft as first report received.....	1	3
Only bulb suture report received.....	2	74
Primary, etc., section reported as "unknown".....	122	4
Total.....	130	153

TABLE 2.—*Single and multiple nerve injuries (total cases)*

Type of injury	OS	ZI	Total	
			Actual	Percent
Single nerve injuries ¹	1,154	4,594	5,748	90.7
Multiple nerve injuries ²	111	477	588	9.3
Total number of individuals with nerve injuries.....	1,265	5,071	6,336	100.0

¹ Individuals with only 1 nerve injury requiring end-to-end anastomosis or graft procedure.

² Individuals with 2 or more nerve injuries requiring end-to-end anastomosis or graft procedure.

TABLE 3.—*Postoperative nerve condition (total cases)*

Nerve condition ¹	OS	ZI	Total
Suture-line disruption.....	19	44	63
Infection after suture.....	13	26	39

¹ As shown either on assessment or report of reoperation.

NOTE.—Though there were 4 times as many ZI cases as OS cases, there were only about 2 times as many individuals on whom either suture-line separation or infection after suture were reported. The number of the latter cases, however, is so small as to make any generalization on this difference subject to some doubt.

TABLE 4.—Dispositions and time lost from duty (total cases)

Type of disposition	Time lost from duty (weeks)									Total	Average weeks lost
	Less than 30	30-39	40-49	50-59	60-69	70-79	80-89	90-99	100 and over		
Full duty:											
OS.....	1		1	1	1					4	45.3
ZI.....	1			2						3	43.0
Total.....	2		1	3	1					7	44.3
Limited duty on account of nerve injury:											
OS.....	6	10	2	4	2				1	25	41.0
ZI.....	6	11	7	6	2	2		1		35	43.5
Total.....	12	21	9	10	4	2		1	1	60	42.5
CDD or retired on account of nerve injury:											
OS.....	7	33	29	45	18	2	1		1	136	47.9
ZI.....	13	37	53	62	56	12	6	7	18	264	56.9
Total.....	20	70	82	107	74	14	7	7	19	400	53.8
CDD for other reasons:											
OS.....			2	1						3	43.6
ZI.....		1	2		1		1	1	1	7	67.4
Total.....		1	4	1	1		1	1	1	10	60.3
Other dispositions: ¹											
OS.....											
ZI.....	1		4						1	6	49.5
Total.....	1		4						1	6	49.5
Total dispositions:											
OS.....	14	43	34	51	21	2	1		2	168	46.7
ZI.....	21	49	66	70	59	14	7	9	20	315	55.4
Total.....	35	92	100	121	80	16	8	9	22	483	52.4

¹ Other dispositions include 1 accidental death, 2 cases separated by sec. VIII, and 3 transfers to plastic or orthopedic sections.

NOTE.—483 cases in the present study received dispositions after an average duration of treatment of 52.4 weeks. Of these total dispositions, 400 cases, or about 83 percent, had been given CDD (certificate of disability for discharge) or retirement because of the nerve injury.

Men who were returned to duty (either full or limited) had significantly less time under treatment than those whose disposition involved separation from service. The explanation may be (1) doubtful cases could be returned to limited duty and still be kept under observation, and (2) men who were to be CDD'd were kept in the service until recovery was fairly complete or until further treatment was inadvisable.

On the average, patients who received their first definitive treatment in a ZI installation were retained under treatment about 9 weeks longer than those who were first operated on overseas.

TABLE 5.—*Causative agent (total cases)*

Causative agent	OS	ZI	Total
Battle wounds:			
Battle wound (unspecified) ¹	54	110	164
Gunshot wound or bullet.....	341	1,560	1,901
Shell or bomb fragment, shrapnel.....	767	2,972	3,739
Landmine, boobytrap, grenade.....	35	115	150
Aircraft crash (combat).....		4	4
Other battle wounds.....	3	21	24
Total	1,200	4,782	5,982
Accidental wounds:			
Aircraft crash (noncombat).....		4	4
Motor vehicle.....	5	27	32
Accidental gunshot wound or bullet.....	11	38	49
Accidental shell-fragment wound, etc.....	1	15	16
Knife or glass (cut or stab).....	28	91	119
All other accidents ²	12	69	81
Total	57	244	301
Unreported or unknown.....	8	45	53
Total number of individuals with nerve injuries	1,265	5,071	6,336

¹ The group classified as "battle wound (unspecified)" consists of cases reporting cause of injury as "wounded in action," "caused by enemy fire," etc.

² "All other accidents" includes—

OS: Accidental laceration (5), fall (4), falling or moving object (2), previous surgery (1).

ZI: Accidental laceration (15), fall (14), falling or moving object (10), explosion (6), previous surgery (11), crushed by machinery (6), other (7).

NOTE.—Gross classification of the total number of cases shows the following percentage breakdown: 94.4 percent of the total injuries were caused by battle wounds, 4.8 percent were caused by accidental injury, and 0.8 percent of the cases showed cause either as unknown or unreported.

The most important single cause of injury was shell or bomb fragments, accounting for 59 percent of the total injuries. Small arms fire (gunshot wound or bullet) was next in importance, with 30 percent of the total number of nerve injuries.

TABLE 6.—*Bone, vascular, or soft-tissue injury (total cases)*¹

Type of damage	Number of cases			Percentage of total reported		
	OS	ZI	Total	OS	ZI	Total
No bone, vascular, or soft-tissue damage.....	714	2,238	2,952	65.0	46.4	49.8
Bone injury only.....	244	1,744	1,988	22.1	36.1	33.4
Vascular injury only.....	92	409	501	8.4	8.5	8.5
Soft-tissue injury only.....	12	92	104	1.1	1.9	1.8
Bone and vascular injury.....	25	200	225	2.3	4.1	3.8
Bone and soft-tissue injury.....	10	112	122	.9	2.3	2.1
Vascular and soft-tissue injury.....		19	19		.4	.3
Bone, vascular, and soft-tissue injury.....	2	14	16	.2	.3	.3
Total cases with bone, vascular, or soft-tissue injury.....	385	2,590	2,975	35.0	53.6	50.2
Total reported.....	1,099	4,828	5,927	100.0	100.0	100.0

¹ Soft-tissue injury includes only those cases requiring plastic procedure, showing marked loss of soft-tissue substance or severe infection.

NOTE.—Reports on the presence or absence of bone, vascular, or soft-tissue damage were received on 5,927 cases (93.5 percent of the total number of individuals under study), as against only 409 (166 overseas and 243 in the Zone of Interior) cases which failed to report this item or reported it as unknown. All calculations of percentage distribution, therefore, have been based on the total number of cases on which definite information on this item has been received.

About ½ (49.8 percent) of the cases in this latter group stated that no complicating injury was encountered. The remaining half (50.2 percent) showed either bone, vascular, or soft-tissue damage or some combination of the three.

Bone injury was the greatest single complication, appearing either alone or in conjunction with some other type of damage in 39.6 percent of the total cases reported. Vascular injury was present in 12.9 percent of the cases. Soft-tissue damage appeared in 4.5 percent of the total cases reported.

A comparison of OS and ZI cases shows that bone, vascular, or soft-tissue damage was present in only 35 percent of the cases operated on overseas, while 53.6 percent of the ZI cases reported 1 or more of these conditions. This difference may be accounted for by the fact that the more seriously complicated cases were probably sent back to this country and definitive treatment postponed until these conditions had been at least partly relieved.

TABLE 7.—Interval from injury to first operation (primary or graft), (total cases)¹

Interval (tenths of months)	Actual number of cases	Cumulative number of cases	Cumulative percent	Interval (tenths of months)	Actual number of cases	Cumulative number of cases	Cumulative percent
0.....	146	146	2.1	19.....	68	964	13.8
1.....	29	175	2.5	20.....	78	1,042	14.9
2.....	12	187	2.7	21.....	62	1,104	15.8
3.....	13	200	2.9	22.....	54	1,158	16.6
4.....	13	213	3.1	23.....	61	1,219	17.5
5.....	8	221	3.2	24.....	56	1,275	18.3
6.....	15	236	3.4	25.....	76	1,351	19.4
7.....	26	262	3.8	26.....	93	1,444	20.7
8.....	31	293	4.2	27.....	72	1,516	21.7
9.....	36	329	4.7	28.....	100	1,616	23.1
10.....	40	369	5.3	29.....	86	1,702	24.3
11.....	57	426	6.1	30-39.....	1,015	2,717	39.1
12.....	65	491	7.0	40-49.....	1,082	3,799	55.0
13.....	64	555	7.9	50-59.....	929	4,728	68.5
14.....	67	622	8.9	60-69.....	701	5,429	78.6
15.....	75	697	10.0	70-79.....	446	5,875	85.1
16.....	70	767	11.0	80-89.....	313	6,188	89.6
17.....	65	832	11.9	90 and over.....	697	6,885	99.7
18.....	64	896	12.8	Unknown.....	22	6,907	100.0

¹ Exclusive of bulb sutures (214), secondary or tertiary operations (191), and primary after graft (15).

NOTE.—This table shows the length of time which elapsed between the date of injury and the first attempt at actual nerve repair. The table includes only those cases (6,907) on which reports of primary operation or initial graft were received. Thus, 146 cases (2.1 percent of total) received definitive treatment within the same tenth of a month as the injury; 175 received treatment either within the same tenth or the following tenth of a month after injury, and so forth.

Within 1 month after injury (the same interval as the injury plus the following 9 intervals) 329 cases, or 4.7 percent of the total, had received reparative surgery. At the end of 2 months, 13.8 percent of the cases had been treated and so forth. (Compare with table 7(a) for difference between OS and ZI cases.)

On 22 cases, either the date of injury or the date of operation was reported as unknown.

TABLE 7(a).—Interval from injury to first operation (primary or graft) OS and ZI ¹

Interval (tenths of months)	Actual number of cases		Cumulative number of cases		Cumulative percent		Interval (tenths of months)	Actual number of cases		Cumulative number of cases		Cumulative percent	
	OS	ZI	OS	ZI	OS	ZI		OS	ZI	OS	ZI	OS	ZI
0.....	119	27	119	27	8.7	0.5	19.....	46	22	833	131	60.1	2.4
1.....	29	1	148	27	10.8	.5	20.....	49	29	882	160	63.6	2.9
2.....	11	1	159	28	11.6	.5	21.....	39	23	921	183	66.4	3.3
3.....	9	4	168	32	12.2	.6	22.....	29	25	950	208	68.5	3.8
4.....	12	1	180	33	13.1	.6	23.....	27	34	977	242	70.4	4.4
5.....	7	1	187	34	13.6	.6	24.....	23	33	1,000	275	72.1	5.0
6.....	15	2	202	34	14.7	.6	25.....	35	41	1,035	316	74.6	5.7
7.....	24	2	226	36	16.4	.6	26.....	34	59	1,069	375	77.1	6.8
8.....	30	1	256	37	18.6	.6	27.....	20	52	1,089	427	78.5	7.7
9.....	31	5	287	42	20.8	.7	28.....	25	75	1,114	502	80.3	9.1
10.....	39	1	326	43	23.6	.7	29.....	16	70	1,130	572	81.5	10.4
11.....	52	5	378	48	27.3	.8	30-39.....	102	913	1,232	1,485	89.0	26.9
12.....	60	5	438	53	31.6	.9	40-49.....	52	1,030	1,284	2,515	92.7	45.7
13.....	61	3	499	56	36.0	1.0	50-59.....	24	905	1,308	3,420	94.4	62.1
14.....	62	5	561	61	40.5	1.1	60-69.....	19	682	1,327	4,102	95.8	74.4
15.....	64	11	625	72	45.1	1.3	70-79.....	9	437	1,336	4,539	96.4	82.3
16.....	59	11	684	83	49.4	1.5	80-89.....	14	299	1,350	4,838	97.4	87.7
17.....	50	15	734	98	53.0	1.8	90 and over.....	28	669	1,378	5,507	99.4	99.8
18.....	53	11	787	109	56.8	2.0	Unknown.....	9	13	1,387	5,520	100.0	100.0

¹ Exclusive of—

	OS	ZI
Bulb sutures.....	18	196
Secondary or tertiary operations.....	56	135
Primary after graft.....	1	14
Total.....	75	345

NOTE.—See table 7 for explanation of data and procedure.

About 20 percent of the OS cases received the first attempt at surgical repair within the first month after injury, 40 percent during the second month, and 20 percent during the third month. Thus, a total of over 80 percent of the OS cases received definitive treatment within the first 3 months after nerve injury.

The comparable figure for ZI cases for the same period was only 10 percent. The great bulk of ZI cases (about 90 percent) did not receive the first primary or graft operation until 3 months or more had elapsed after injury. The period of greatest activity on ZI cases was in the 3-month interval from the 4th through the 6th month after injury, with over one-half of the total cases receiving first definitive treatment in that period.

TABLE 8.—Operative procedure end-to-end anastomosis (total cases)¹

End-to-end anastomosis	Number of cases			Percentage of total reported		
	OS	ZI	Total	OS	ZI	Total
Complete.....	1,237	5,127	6,364	90.1	91.5	91.2
Partial.....	136	476	612	9.9	8.5	8.8
Information unavailable.....	60	2	62			
With tantalum wire.....	958	3,294	4,252	74.4	59.0	61.9
With other suture material.....	313	1,822	2,135	24.3	32.7	31.1
With tantalum wire and other suture material.....	17	463	480	1.3	8.3	7.0
No entry or information unavailable ²	145	26	171			
With stay suture.....	398	973	1,371	39.8	17.5	20.9
Without stay suture.....	601	4,599	5,200	60.2	82.5	79.1
Information unavailable.....	434	33	467			
Wrapped in tantalum foil.....	738	1,610	2,348	98.3	98.0	98.1
Wrapped in other cuff material.....	13	33	46	1.7	2.0	1.9
No entry or information unavailable.....	682	3,962	4,644			
With mobilization.....	628	3,405	4,033	71.2	68.3	68.7
With transplantation.....	108	287	395	12.2	5.8	6.7
With mobilization and transplantation.....	147	1,293	1,440	16.6	25.9	24.6
No entry or information unavailable.....	550	620	1,170			
Bone resection.....	13	104	117			
No entry or information unavailable.....	1,420	5,501	6,921			

¹ Excluding all bulb sutures.

² "No entry" signifies items were left blank; "information unavailable" signifies that the reporting hospital lacked information on the items.

TABLE 9.—Rate of advance in Tinel's sign, by interval after operation (total cases)

Tinel's sign (in cm.)	Interval after operation to assessment (in months)													Total
	0-1.9	2-2.9	3-3.9	4-4.9	5-5.9	6-6.9	7-7.9	8-8.9	9-9.9	10-10.9	11-11.9	12-12.9	13+	
0.....	121	108	313	80	53	94	32	21	28	16	10	11	34	921
0.1-2.9.....	18	27	36	8	2	6	1	2					1	101
3.0-5.9.....	30	69	198	28	16	26	12	6	2	1			5	393
6.0-8.9.....	12	51	239	42	17	33	7	6	4	5	1	1		418
9.0-11.9.....	14	42	221	58	23	36	8	3	11	1	2	2	5	426
12.0-14.9.....	9	28	152	26	22	45	9	8	13	7	1	1	2	323
15.0-17.9.....	11	51	186	41	48	57	16	10	12	2	1	2	6	443
18.0-20.9.....	2	44	213	42	63	108	29	15	25	2	1	5	1	550
21.0-23.9.....		15	100	17	14	34	4	7	13	3	2	1	3	213
24.0-26.9.....	1	10	134	45	37	79	24	17	27	7	3	7	4	395
27.0-29.9.....		5	47	9	10	37	5	7	13	4	1	3	2	143
30.0-32.9.....		13	89	33	48	97	32	23	39	11	12	6	5	408
33.0-35.9.....		5	27	9	24	84	12	14	26	14	7	13	7	242
36.0-38.9.....			20	10	5	34	9	3	16	3	3	9	2	114
39.0-41.9.....		1	21	12	20	67	11	11	25	7	7	10	4	196
42.0-44.9.....	1		11	3	8	37	5	5	17	6		1	2	96
45.0-59.9.....		2	22	8	22	120	25	34	57	12	17	31	35	385
60.0-98.9.....			5	3	4	26	2	10	36	8	5	15	16	130
Complete.....		2	6	1	5	15	8	7	13	6	2	8	12	85
Unknown or unreported.....	3	18	26	9	6	17	5	3	5	4			15	101
Total assessments.....	222	491	2,066	484	447	1,052	256	212	382	119	75	126	151	6,083
Average advance.....	8.3	13.0	16.7	19.6	24.7	30.4	27.9	33.3	37.8	35.8	40.2	43.9	42.8	23.9

¹ Includes 1 case on which date of operation is unknown.

NOTE.—This table was based on the total number of assessments received on 4,137 operations. The assessments were distributed by the interval, in months, between each operation and its corresponding assessments, and, within each time interval, by the reported advance of Tinel's sign distally from the suture line. Thus, 2,066 cases were assessed during the 4th month after operation; the distribution of these cases according to the distal advance of Tinel's sign as of that time is shown in column 3-3.9.

The average advance of Tinel's sign for each time interval, based on the assessments within that interval, is shown at the bottom of the table. Cases reporting Tinel's sign as "none," "unknown," or "completed" were excluded from the calculations of these figures.

TABLE 9(a).—Rate of advance of Tinel's sign, by interval after operation (OS cases)

Tinel's sign (in cm.)	Interval after operation to assessment (in months)													Total
	0-1.9	2-2.9	3-3.9	4-4.9	5-5.9	6-6.9	7-7.9	8-8.9	9-9.9	10-10.9	11-11.9	12-12.9	13+	
0.....	48	32	62	39	15	23	9	8	11	7	2	5	8	269
0.1.....	14	8	6	6	2	5	1	1						43
3.0-5.0.....	19	28	47	10	5	9	5	4	1	1			3	132
6.0-8.9.....	5	18	50	23	10	11	2	3	1	2				125
9.0-11.9.....	11	18	42	18	8	13	3	1	4		2		2	122
12.0-14.9.....	6	11	31	10	9	15	3	4	6	5			1	101
15.0-17.9.....	9	14	40	13	21	17	7	5	4	2	1	1	2	136
18.0-20.9.....	2	9	43	17	22	26	14	9	11	1	1	3		158
21.0-23.9.....		6	27	8	5	11	3	3	6	1				70
24.0-26.9.....	1	3	21	13	7	33	14	7	16	2	2			119
27.0-29.9.....		1	4	2	3	12		2	5	2	1	1		33
30.0-32.9.....		8	14	16	20	22	19	13	25	8	6	4	1	156
33.0-35.9.....		1	10	4	6	24	6	6	13	8	5	8	4	95
36.0-38.9.....			7	4	1	11	2	2	4	2		2	2	37
39.0-41.9.....		1	6	4	4	21	5	7	12	3	4	6	2	75
42.0-44.9.....			3	2	4	12	1	4	3	2			1	32
45.0-59.9.....		1	6	2	3	34	9	12	22	3	12	16	9	129
60.0-98.9.....			1	1	1	4	2	2	19	3	2	7	4	46
Complete.....			3	1	2	7	4	2	3	1	1	6	3	33
Unknown or unreported.....	1	7	6	4	2	6	2	1	2	1			12	34
Total assessments.....	116	166	429	197	150	316	111	96	168	54	39	59	44	1,945
Average advance.....	8.3	12.9	16.8	18.9	22.2	28.9	27.9	30.7	38.0	32.8	40.3	46.3	40.0	24.6

* Includes 1 case on which date of operation is unknown.

TABLE 9(b).—Rate of advance of Tinel's sign, by interval after operation (ZI cases)

Tinel's sign (in cm.)	Interval after operation to assessment (in months)													Total
	0-1.9	2-2.9	3-3.9	4-4.9	5-5.9	6-6.9	7-7.9	8-8.9	9-9.9	10-10.9	11-11.9	12-12.9	13+	
0.....	73	76	251	41	38	71	23	13	17	9	8	6	26	652
0.1-2.9.....	4	19	30	2		1		1					1	58
3.0-5.9.....	11	41	151	18	11	17	7	2	1				2	261
6.0-8.9.....	7	33	189	19	7	22	5	3	3	3	1	1		293
9.0-11.9.....	3	24	179	40	15	23	5	2	7	1		2	3	304
12.0-14.9.....	3	17	121	16	13	30	6	4	7	2	1	1	1	222
15.0-17.9.....	2	37	146	28	27	40	9	5	8			1	4	307
18.0-20.9.....		35	170	25	41	82	15	6	14	1		2	1	392
21.0-23.9.....		9	73	9	9	23	1	4	7	2	2	1	3	143
24.0-26.9.....		7	113	32	30	46	10	10	11	5	1	7	4	276
27.0-29.9.....		4	43	7	7	25	5	5	8	2		2	2	110
30.0-32.9.....		5	75	17	28	75	13	10	14	3	6	2	4	252
33.0-35.9.....		4	17	5	18	60	6	8	13	6	2	5	3	147
36.0-38.9.....			13	6	4	23	7	1	12	1	3	7		77
39.0-41.9.....			15	8	16	46	6	4	13	4	3	4	2	121
42.0-44.9.....	1		8	1	4	25	4	1	14	4		1	1	64
45.0-59.9.....		1	16	6	19	86	16	22	35	9	5	15	26	256
60.0-98.9.....			4	2	3	22		8	17	5	3	8	12	84
Complete.....		2	3		3	8	4	5	10	5	1	2	9	52
Unknown or unreported.....	2	11	20	5	4	11	3	2	3	3			3	67
Total assessments.....	106	325	1,637	287	297	736	145	116	214	65	36	67	107	4,138
Average advance.....	8.3	13.0	16.6	19.9	26.0	31.1	27.8	35.6	37.7	38.6	40.2	42.1	44.1	23.6

TABLE 10.—Rate of motor recovery, by interval after operation (total cases)

Motor recovery code	Interval after operation to assessment (in months)													Total
	0-1.9	2-2.9	3-3.9	4-4.9	5-5.9	6-6.9	7-7.9	8-8.9	9-9.9	10-10.9	11-11.9	12-12.9	13+	
0.....	198	409	1,598	330	261	490	115	79	139	34	16	33	154	3,756
1.....	14	51	273	91	108	271	63	66	108	23	21	36	29	1,154
2.....	6	18	125	49	61	226	53	42	104	37	24	44	45	834
3.....	1	5	21	8	12	41	18	17	26	20	11	10	17	207
4.....		1	4		1	6	3	4	3	4	2	2	2	32
No loss.....		2	6	1	2	7			1					19
Unknown or unreported.....	3	5	38	5	2	12	4	5	1	1	1		4	81
Total assessments.....	222	491	2,065	484	447	1,053	256	213	382	119	75	125	151	6,083

1 Includes 1 case on which date of operation was unknown.

TABLE 10(a).—Rate of motor recovery, by interval after operation (OS cases)

Motor recovery code	Interval after operation to assessment (in months)													Total
	0-1.9	2-2.9	3-3.9	4-4.9	5-5.9	6-6.9	7-7.9	8-8.9	9-9.9	10-10.9	11-11.9	12-12.9	13+	
0.....	102	140	324	133	90	140	52	30	54	16	6	15	11	1,113
1.....	6	15	60	35	33	78	28	33	50	5	11	18	6	378
2.....	5	5	29	21	19	78	18	23	49	17	13	19	14	310
3.....		2	6	4	7	12	9	7	12	11	7	6	11	94
4.....			1			2	1	1	1	4	2	1		13
No loss.....		2	1	1	1	4			1					10
Unknown or unreported.....	3	2	8	3		2	3	2	1	1			2	27
Total assessments.....	116	166	429	197	150	316	111	96	168	54	39	59	144	1,945

¹ Includes 1 case on which date of operation was unknown.

TABLE 10(b).—Rate of motor recovery, by interval after operation (ZI cases)

Motor recovery code	Interval after operation to assessment (in months)													Total
	0-1.9	2-2.9	3-3.9	4-4.9	5-5.9	6-6.9	7-7.9	8-8.9	9-9.9	10-10.9	11-11.9	12-12.9	13+	
0.....	96	269	1,274	197	171	350	63	49	85	18	10	18	43	2,643
1.....	8	36	213	56	75	193	35	33	58	18	10	18	23	776
2.....	1	13	96	28	42	148	35	19	55	20	11	25	31	524
3.....	1	3	15	4	5	29	9	10	14	9	4	4	6	113
4.....		1	3		1	4	2	3	2			1	2	19
No loss.....			5		1	3								9
Unknown or unreported.....		3	30	2	2	10	1	3			1		2	54
Total assessments.....	106	325	1,636	287	297	737	145	117	214	65	36	66	107	4,138

TABLE 11.—Rate of sensory recovery, by interval after operation (total cases)

Sensory recovery code	Interval after operation to assessment (in months)													Total
	0-1.9	2-2.9	3-3.9	4-4.9	5-5.9	6-6.9	7-7.9	8-8.9	9-9.9	10-10.9	11-11.9	12-12.9	13+	
0.....	202	423	1,674	340	265	520	109	70	118	28	13	28	47	3,837
1.....	10	36	267	91	111	331	74	75	156	39	23	48	43	1,304
2.....	4	13	55	34	45	139	47	36	67	29	16	27	27	539
3.....		3	18	4	19	46	20	26	26	20	15	17	28	242
4.....		4	7	3		6	2	2	10	3	6	5	6	54
No loss.....		1	4	1		2								8
Unknown or unreported.....	6	11	40	11	7	9	4	3	5		2	1		99
Total assessments.....	222	491	2,065	484	447	1,053	256	212	382	119	75	126	151	6,083

¹ Includes 1 case on which date of operation was unknown.

TABLE 11(a).—Rate of sensory recovery, by interval after operation (OS cases)

Sensory recovery code	Interval after operation to assessment (in months)													Total
	0- 1.9	2- 2.9	3- 3.9	4- 4.9	5- 5.9	6- 6.9	7- 7.9	8- 8.9	9- 9.9	10- 10.9	11- 11.9	12- 12.9	13+	
0.....	102	144	338	136	86	133	41	28	41	7	6	10	17	1,079
1.....	8	14	59	36	37	109	33	32	70	19	12	19	14	462
2.....	2	7	21	17	18	47	23	18	34	17	8	15	8	235
3.....			5	3	9	21	13	17	11	9	10	12	13	123
4.....			2	1		4			7	2	2	3	2	23
No loss.....														
Unknown or unreported.....	4	1	4	4		2	1	1	5		1			23
Total assessments.....	116	166	429	197	150	316	111	96	168	54	39	59	144	1,945

¹ Includes 1 case on which date of operation was unknown.

TABLE 11(b).—Rate of sensory recovery, by interval after operation (ZI cases)

Sensory recovery code	Interval after operation to assessment (in months)													Total
	0- 1.9	2- 2.9	3- 3.9	4- 4.9	5- 5.9	6- 6.9	7- 7.9	8- 8.9	9- 9.9	10- 10.9	11- 11.9	12- 12.9	13+	
0.....	100	279	1,336	204	179	387	68	42	77	21	7	18	50	2,758
1.....	2	22	208	55	74	222	41	43	86	20	11	29	29	842
2.....	2	6	34	17	27	92	24	18	33	12	8	12	19	304
3.....		3	13	1	10	25	7	9	15	11	5	5	15	119
4.....		4	5	2		2	2	2	3	1	4	2	4	31
No loss.....		1	4	1		2								8
Unknown or unreported.....	2	10	36	7	7	7	3	2			1	1		76
Total assessments.....	106	325	1,636	287	297	737	145	116	214	65	36	67	107	4,138

TABLE 12.—*First appearance of Tinel's sign in operations with assessment, by time after operation (total cases)*

Interval after operation to assessment (months)	With appearance of Tinel's sign ¹			No appearance of Tinel's sign ²
	With previous assessment showing Tinel sign as 0	No previous assessment	Total	
0-1.9.....		96	96	86
2-2.9.....	3	357	360	67
3-3.9.....	21	1,670	1,691	231
4-4.9.....	15	345	360	57
5-5.9.....	22	220	242	32
6-6.9.....	83	267	350	59
7-7.9.....	18	79	97	24
8-8.9.....	17	71	88	17
9-9.9.....	25	77	102	18
10-10.9.....	8	25	33	10
11-11.9.....	5	11	16	8
12-12.9.....	6	17	23	8
13 and over.....	5	43	48	13
Unknown ³				1
Total.....	228	3,278	3,506	631

¹ Distributed by first assessment which showed a positive Tinel's sign.

² Distributed by latest assessment received.

³ Date of operation unknown.

NOTE.—Table 12 consists of 2 separate sections. The first shows 3,506 operations on which Tinel's sign has appeared, broken down into those cases (3,278) which reported a definite value for Tinel's sign on the first assessment, and those cases (228) on which Tinel's sign did not appear until after a previous assessment which had reported the sign as "none" or "unknown." For each of these subgroups, the table shows the distribution according to the interval between operation and the assessment on which Tinel's sign first appeared.

The second major group, 631 cases with no appearance of Tinel's sign on any assessment, was tabulated by the interval between operation and the last assessment report. The intention in this section is to show the length of time which has elapsed since each operation with still no evidence of recovery.

For example, during the 4th month after operation (3-3.9 months) 1,691 cases reported the presence of Tinel's sign for the first time, 21 of them having previously reported it as absent or unknown. During the same period, the last report received on 231 cases showed a continued absence of the Tinel.

TABLE 12(a).—*First appearance of Tinel's sign in operations with assessment, by time after operation (OS and ZI)*

Interval after operation to assessment (months)	With appearance of Tinel's sign ¹						No appearance of Tinel's sign ²	
	With previous assessment showing Tinel sign as 0		No previous assessment		Total		OS	ZI
	OS	ZI	OS	ZI	OS	ZI		
0-1.9.....			67	29	67	29	22	64
2-2.9.....	1	2	121	236	122	238	22	45
3-3.9.....	6	15	329	1,341	335	1,356	36	195
4-4.9.....	9	6	124	221	133	227	28	29
5-5.9.....	7	15	78	142	85	157	9	23
6-6.9.....	28	55	121	146	149	201	12	47
7-7.9.....	7	11	40	39	47	50	6	18
8-8.9.....	9	8	33	38	42	46	6	11
9-9.9.....	11	14	39	38	50	52	8	10
10-10.9.....	5	3	13	12	18	15	4	6
11-11.9.....	3	2	2	9	5	11	1	7
12-12.9.....		6	8	9	8	15	4	4
13 and over.....	1	4	12	31	13	35	8	5
Unknown ³							1	
Total.....	87	141	987	2,291	1,074	2,432	167	464

¹ Distributed by first assessment which showed a positive Tinel's sign.

² Distributed by latest assessment received.

³ Date of operation unknown.

NOTE.—At first inspection, the total columns of the cases on which Tinel's sign has appeared seem to indicate that ZI cases recovered the Tinel earlier than did OS cases. By the end of the 4th month after operation, for example, 66.7 percent (1,623 cases) of the total of 2,432 ZI cases in this column had reported the initial appearance of Tinel's sign. For the OS cases, the corresponding percentage is only 48.8 percent (524 of the total of 1,074 cases). This percentage lead of the ZI cases continues with a gradually decreasing differential with the inclusion of succeeding intervals until, at the end of the 9th month, the comparable percentages are practically equal at about 96 percent.

Any conclusions drawn from this comparison, however, must be severely modified by 2 facts: (1) Assessments on OS cases did not fall into the regular 3-, 6-, 9-, 12-month pattern as well as ZI cases; (2) on the average, the first assessments on ZI cases were made sooner after operation than were those on OS cases, thus tending to distort the first reports of Tinel recovery in favor of the ZI cases.

TABLE 13.—*First evidence of motor recovery in operations with assessment, by time after operation (total cases)*

Interval after operation to assessment (months)	With evidence of recovery ¹			No evidence of recovery ²
	With previous assessment showing recovery as 0	No previous assessment	Total	
0-1.9.....		14	14	121
2-2.9.....		57	57	237
3-3.9.....	9	341	350	1,051
4-4.9.....	17	110	127	203
5-5.9.....	64	96	160	208
6-6.9.....	277	165	442	381
7-7.9.....	53	56	109	79
8-8.9.....	39	57	96	49
9-9.9.....	79	60	139	80
10-10.9.....	28	25	53	16
11-11.9.....	8	12	20	12
12-12.9.....	21	13	34	20
13 and over.....	12	48	60	18
Unknown ³				
Total.....	607	1,054	1,661	2,476

¹ Distributed by first assessment reporting evidence of recovery.

² Distributed by latest assessment received.

³ Date of operation unknown.

NOTE.—As in table 12, this table should be considered as composed of 2 separate sections. The first consists of those operations (1,661) on which motor recovery has been reported positively, with the cases broken down according to whether the recovery was reported on the first assessment or on a later assessment after an earlier report showing no recovery; both types of cases are tabulated by the time interval between operation and the assessment which first showed some degree of motor recovery. The second section is made up of those operations (2,476) whose assessments have shown no indication of motor recovery at any time; these cases are tabulated by the interval between the operation and the latest assessment on each operation.

Thus, during the 4th month after operation (3-3.9 months) 350 cases reported for the first time that motor recovery was beginning; in 9 of these the report followed a previous report showing motor recovery as 0. In the same interval, 1,051 cases, according to their latest assessments, had never shown evidence of recovery.

TABLE 13(a).—*First evidence of motor recovery in operations with assessment, by time after operation (OS and ZI)*

Interval after operation to assessment (months)	With evidence of recovery ¹						No evidence of recovery ²	
	With previous assessment showing recovery as 0		No previous assessment		Total		OS	ZI
	OS	ZI	OS	ZI	OS	ZI		
0-1.9.....			10	4	10	4	43	78
2-2.9.....			21	36	21	36	81	156
3-3.9.....	6	3	81	260	87	263	183	868
4-4.9.....	10	7	43	67	53	74	74	129
5-5.9.....	17	47	41	55	58	102	59	149
6-6.9.....	74	203	82	83	156	286	83	298
7-7.9.....	22	31	29	27	51	58	30	49
8-8.9.....	18	21	24	33	42	54	19	30
9-9.9.....	34	45	34	26	68	71	25	55
10-10.9.....	15	13	15	10	30	23	5	11
11-11.9.....	5	3	2	10	7	13	5	7
12-12.9.....	9	12	6	7	15	19	7	13
13 and over.....	6	6	14	34	20	40	8	10
Unknown ³							1	
Total.....	216	391	402	652	618	1,043	623	1,853

¹ Distributed by first assessment reporting evidence of recovery.

² Distributed by latest assessment received.

³ Date of operation unknown.

NOTE.—As was the case on Tinel's sign (table 12(a)), the initial reports of motor recovery on ZI cases fall more heavily into the early intervals after operation than do those on OS cases. On the surface, this seems to indicate an earlier appearance of motor recovery on ZI as compared to OS cases. 2 weaknesses in the data, however, make the validity of such a conclusion doubtful: (1) The interval between an OS operation and the first assessment report is, on the average, longer than on a ZI operation; and (2) the early assessments on OS cases are made at more irregular intervals than those on ZI cases. (See note on table 12(a).)

The above objections to the reliability of the data seem to be borne out by the fact that those cases which have never reported recovery show the same type of relationship between the distributions of OS and ZI groups as do the cases on which recovery has appeared. The conclusion seems to be that the seemingly favorable results in the ZI group are due more to the nature of the basic data than to actual earlier recovery.

TABLE 14.—*First evidence of sensory recovery in operations with assessment, by time after operation (total cases)*

Interval after operation to assessment (months)	With evidence of recovery ¹			No evidence of recovery ²
	With previous assessment showing recovery as 0	No previous assessment	Total	
0-1.9.....	1	20	21	114
2-2.9.....		77	77	225
3-3.9.....	6	421	427	1,014
4-4.9.....	15	130	145	202
5-5.9.....	54	105	159	185
6-6.9.....	274	152	426	346
7-7.9.....	53	48	101	76
8-8.9.....	41	50	91	60
9-9.9.....	79	45	124	87
10-10.9.....	30	17	47	23
11-11.9.....	13	12	25	14
12-12.9.....	31	13	44	25
13 and over.....	16	41	57	21
Unknown ³				1
Total.....	613	1,131	1,744	2,393

¹ Distributed by first assessment reporting evidence of recovery.

² Distributed by latest assessment received.

³ Date of operation unknown.

NOTE.—The data on sensory recovery were handled and tabulated in the same manner as the data on motor recovery. (See notes on table 13.) Cases showing evidence of sensory recovery at any time after operation (1,744 cases) were tabulated by the interval between operation and the first assessment which reported the beginning of recovery; the 2,393 cases showing no recovery on any assessment were tabulated by the interval between operation and the latest assessment.

This table may be read in the same manner as table 13. During the 4th month after operation, 427 cases showed signs of sensory recovery for the first time. Of these, 421 were cases on which the first assessment fell within this period; 6 had previously reported sensory recovery as 0 on earlier assessments. During the same interval, the last assessment on 1,014 cases showed no sensory recovery as of that time.

TABLE 14(a).—*First evidence of sensory recovery in operations with assessment, by time after operation (OS and ZI)*

Interval after operation to assessment (months)	With evidence of recovery ¹						No evidence of recovery ²	
	With previous assessment showing recovery as 0		No previous assessment		Total			
	OS	ZI	OS	ZI	OS	ZI	OS	ZI
0-1.9.....		1	11	9	11	10	40	74
2-2.9.....			24	53	24	53	80	145
3-3.9.....	3	3	94	327	97	330	187	827
4-4.9.....	10	5	48	82	58	87	80	122
5-5.9.....	20	34	33	72	53	106	53	132
6-6.9.....	65	209	74	78	139	287	82	264
7-7.9.....	19	34	24	24	43	58	32	44
8-8.9.....	22	19	23	27	45	46	21	39
9-9.9.....	30	49	21	24	51	73	31	56
10-10.9.....	14	16	11	6	25	22	13	10
11-11.9.....	8	5	2	10	10	15	5	9
12-12.9.....	15	16	5	8	20	24	10	15
13 and over.....	8	8	14	27	22	35	8	13
Unknown ³							1	
Total.....	214	399	384	747	598	1,146	643	1,750

¹ Distributed by first assessment reporting evidence of recovery.

² Distributed by latest assessment received.

³ Date of operation unknown.

NOTE.—The cases on which sensory recovery has been noted show the same pattern of relationship between the OS and ZI groups as was observed on Tinell's sign and on motor recovery (tables 12(a) and 13(a)). Because of a greater proportion of reports of first recovery in the early months after operation, the ZI cases apparently show earlier sensory return than do the OS cases. However, the reliability of the basis data is open to the same objections which were brought out in the comments on the tables mentioned above. (See notes on tables 12(a) and 13(a).) Here again, the comparatively unfavorable position of OS operations seems to be due largely to the longer interval between operation and first assessment report and to the irregular intervals between the early reports of assessment.

APPENDIX F

Peripheral Nerve Injury Study (Sciatic Nerves)¹

NATURE OF THE DATA

In this study, a case was considered to be a sciatic nerve injury only when the location of injury was in the knee or thigh. The cases included in this section are those on which the involved nerve was reported as "sciatic," "peroneal component of the sciatic," or "tibial component of the sciatic." Injuries to the peroneal or tibial nerves below the knee are not included in this group.

Sciatic nerve injuries, as defined above, were reported on 1,109 individuals. On 82 of these patients, both components of the nerve were injured and were reported as separate cases. Thus the total number of nerve injuries reported was 1,191, of which 585 were reported as injuries to the sciatic nerve, 392 as injuries to the peroneal component, and 214 as injuries to the tibial component.

As in all nerves combined, the sciatic cases were divided into an OS (oversea) group and a ZI (Zone of Interior) group, depending upon the location of the first attempt at actual repair. On this basis, 267 cases (22.4 percent of the total) were classified as OS, while 924 cases (77.6 percent of the total) fell into the ZI group.

Only four cases of sciatic nerve injury received graft procedure as first definitive treatment.

The total number of operations performed on the 1,191 sciatic injuries was 1,234.

TABLE 1.—*Sciatic nerve by type of operative procedure (total cases)*

Location	End-to-end anastomosis as original definitive procedure				Graft as original definitive procedure	Total cases	
	Primary		Other	Total		Actual	Percent
	No previous bulb suture	With previous bulb suture					
Overseas.....	238	4	24	266	1	267	3.8
Zone of Interior.....	863	32	25	920	4	924	13.1
Total.....	1,101	36	49	1,186	5	1,191	16.9

¹ Includes cases with—

	OS	ZI
Secondary as first report received.....	1	14
Primary after graft as first report received.....	—	1
Only bulb suture report received.....	—	9
Primary, etc., section reported as "unknown".....	23	1
Total.....	24	25

¹ This analysis was prepared by the Medical Statistics Division, Office of the Surgeon General, and submitted to the Historical Unit, U.S. Army Medical Service, on 22 August 1956. The data were derived from material in the World War II Peripheral Nerve Registry from the date of the Registry's establishment up to the date of 1 November 1945.

TABLE 2.—*Single and multiple sciatic nerve injuries (total cases)*

Type of injury	OS	ZI	Total	
			Actual	Percent
Single nerve injuries.....	231	796	1,027	92.6
Multiple nerve injuries ¹	18	64	82	7.4
Total.....	249	860	1,109	100.0

¹ Tibial and peroneal components in thigh reported separately.

TABLE 3.—*Postoperative nerve condition (total cases)*

Nerve condition ¹	OS	ZI	Total
Suture-line disruption.....	9	16	25
Infection after suture.....	2	11	13

¹ As shown either on assessment or report of reoperation.

TABLE 4.—Disposition and time lost from duty (total cases)

Type of disposition	Time lost from duty (weeks)									Total	Average weeks lost
	Less than 30	30-39	40-49	50-59	60-69	70-79	80-89	90-99	100 and over		
Limited duty on account of nerve injury:											
OS.....	2			1						3	38.3
ZI.....					1					1	69.0
Total.....	2			1	1					4	46.0
CDD or retired on account of nerve injury:											
OS.....	1	1	1	4	4	1				12	54.3
ZI.....		2	4	3	4	1	1	1	7	23	74.7
Total.....	1	3	5	7	8	2	1	1	7	35	67.7
Other dispositions: ¹											
OS.....											0
ZI.....			1				1			2	67.0
Total.....			1				1			2	67.0
Total dispositions:											
OS.....	3	1	1	5	4	1				15	51.1
ZI.....		2	5	3	5	1	2	1	7	26	73.9
Total.....	3	3	6	8	9	2	2	1	7	41	65.6

¹ Include 1 accidental death and 1 transfer to orthopedic section.

NOTE.—The average duration of treatment for the 41 sciatic cases on which disposition was reported was 65.6 weeks, approximately 13 weeks longer than the average for all nerves combined. (See table 4, app. E.) As in the study of the combined nerves, the great bulk (85 percent) of the dispositions were CDD (certificate of disability for discharge) injury.

In spite of the small number of disposed sciatic cases, the comparison of the OS and ZI groups seems to show a significantly greater difference in the sciatic nerves than in all nerves combined. The average length of treatment on the ZI sciatic group was almost 22 weeks longer than on the corresponding OS cases. The comparable difference for the combined nerves was only 9 weeks.

TABLE 5.—*Causative agent (total cases)*

Causative agent	OS	ZI	Total
Battle wounds:			
Battle wound (unspecified) ¹	17	17	34
Gunshot wound or bullet.....	65	275	340
Shell or bomb fragment, shrapnel.....	157	518	675
Landmine, boobytrap, grenade.....	4	17	21
Aircraft crash (combat).....			
Other battle wounds.....	1	5	6
Total.....	244	832	1,076
Accidental wounds:			
Aircraft crash (noncombat).....		2	2
Motor vehicle.....		2	2
Accidental gunshot wound or bullet.....		4	4
Accidental shell-fragment wound, etc.....		2	2
Knife or glass (cut or stab).....		3	3
All other accidents ²	2	5	7
Total.....	2	18	20
Unreported or unknown.....	3	10	13
Total.....	249	860	1,109

¹ Consists of cases reporting cause of injury as "wounded in action" "causes by enemy fire," etc.

² "All other accidents" includes—

OS: Fall (1), falling or moving object (1).

ZI: Fall (2), falling or moving object (2), fracture (1).

Note.—Of the total number of sciatic nerve injuries, 97 percent were caused by battle wounds, while only 1.8 percent were caused by accidental injuries; in 1.2 percent of the cases the cause of injury was unknown or unreported.

As in all nerves combined, shell or bomb fragments caused about 60 percent of the sciatic nerve injuries, while small arms fire (gunshot wound or bullet) was the causative agent in an additional 30 percent of the total number of cases.

TABLE 6.—*Bone, vascular, or soft-tissue injury (total cases)*¹

Type of damage	Number of cases			Percentage of total reported		
	OS	ZI	Total	OS	ZI	Total
No bone, vascular, or soft-tissue damage.....	170	570	740	82.9	71.3	73.7
Bone injury only.....	21	186	207	10.2	23.3	20.6
Vascular injury only.....	7	8	15	3.4	1.0	1.5
Soft-tissue injury only.....	3	17	20	1.5	2.1	2.0
Bone and vascular injury.....	3	7	10	1.5	.9	1.0
Bone and soft-tissue injury.....	1	10	11	.5	1.3	1.1
Vascular and soft-tissue injury.....		1	1		.1	.1
Total cases with bone vascular or soft-tissue injury.....	35	229	264	17.1	28.7	26.3
Total reported.....	205	799	1,004	100.0	100.0	100.0

¹ Soft-tissue injury includes only those cases requiring plastic procedure, showing marked loss of soft-tissue substance or severe infection. Bone, vascular, or soft-tissue injury was unknown or unreported in 105 of the 1,109 patients with sciatic nerve injuries.

NOTE.—Of the sciatic cases reporting on the item of bone, vascular, or soft-tissue damage, only $\frac{1}{4}$ (26.3 percent) indicated the presence of complicating injuries; in contrast, $\frac{1}{2}$ of the reports on all nerves combined reported this condition. (See note on table 6, app. E.)

Bone injury was again the most important single factor, being present alone or in combination with other injuries in 22.7 percent of the total sciatic cases reporting. Vascular damage was present in 2.6 percent and soft-tissue damage in 3.2 percent of the total cases.

As in the study of the combined nerves, the percentage of OS cases reporting bone, vascular, or soft-tissue damage was less than in the ZI cases. Only 17.1 percent of the OS group of sciatic cases reported 1 or more types of concomitant injury, as compared to 28.7 percent of the ZI group.

TABLE 7.—*Interval from injury to first operation (primary or graft) (total cases)*¹

Interval (tenths of months)	Actual number of cases	Cumulative number of cases	Cumulative percent	Interval (tenths of months)	Actual number of cases	Cumulative number of cases	Cumulative percent
0.....	14	14	1.2	19.....	22	207	17.8
1.....	7	21	1.8	20.....	16	223	19.2
2.....	4	25	2.1	21.....	4	227	19.5
3.....	6	31	2.6	22.....	8	235	20.2
4.....	1	32	2.7	23.....	14	249	21.4
5.....	1	33	2.8	24.....	16	265	22.8
6.....	2	35	3.0	25.....	15	280	24.1
7.....	6	41	3.5	26.....	18	298	25.6
8.....	10	51	4.4	27.....	16	314	27.0
9.....	11	62	5.3	28.....	21	335	28.8
10.....	7	69	5.9	29.....	17	352	30.3
11.....	16	85	7.3	30-39.....	190	542	46.4
12.....	13	98	8.4	40-49.....	181	723	61.8
13.....	7	105	9.0	50-59.....	129	852	72.8
14.....	15	120	10.3	60-69.....	90	942	80.5
15.....	15	135	11.6	70-79.....	59	1,001	85.5
16.....	19	154	13.2	80-89.....	44	1,045	89.3
17.....	16	170	14.6	90 and over.....	122	1,167	99.7
18.....	15	185	15.9	Unknown.....	3	1,170	100.0

¹ Exclusive of bulb sutures (26), secondary or tertiary operations (37), and primary after graft (1).

NOTE.—See table 7, app. E, for explanation of data and procedure.

TABLE 7(a).—Interval from injury to first operation (primary suture or graft), OS and ZI¹

Interval (tenths of months)	Actual number of cases		Cumulative number of cases		Cumulative percent		Interval (tenths of months)	Actual number of cases		Cumulative number of cases		Cumulative percent	
	OS	ZI	OS	ZI	OS	ZI		OS	ZI	OS	ZI	OS	ZI
0.....	11	3	11	3	4.1	0.3	19.....	14	8	179	28	67.0	2.9
1.....	7		18	3	6.7	.3	20.....	8	8	187	36	70.0	3.8
2.....	3	1	21	4	7.8	.4	21.....	2	2	189	38	70.7	4.0
3.....	5	1	26	5	9.7	.5	22.....	3	5	192	43	71.8	4.6
4.....	1		27	5	10.1	.5	23.....	8	6	200	49	74.8	5.3
5.....	1		28	5	10.5	.5	24.....	5	11	205	60	76.7	6.5
6.....	2		30	5	11.2	.5	25.....	7	8	212	68	79.3	7.4
7.....	6		36	5	13.4	.5	26.....	6	12	218	80	81.5	8.7
8.....	9	1	45	6	16.8	.6	27.....	4	12	222	92	83.0	10.1
9.....	11		56	6	20.9	.6	28.....	7	14	229	106	85.6	11.7
10.....	7		63	6	23.5	.6	29.....	1	16	230	122	86.0	13.5
11.....	13	3	76	9	28.4	.9	30-39.....	19	171	249	293	93.2	32.4
12.....	11	2	87	11	32.5	1.1	40-49.....	9	172	258	465	96.6	51.5
13.....	6	1	93	12	34.7	1.2	50-59.....	1	128	259	593	97.0	65.7
14.....	15		108	12	40.3	1.2	60-69.....	3	87	262	680	98.1	75.3
15.....	13	2	121	14	45.2	1.4	70-79.....	1	58	263	738	98.5	81.7
16.....	17	2	138	16	51.7	1.6	80-89.....		44	263	782	98.5	86.6
17.....	15	1	153	17	57.3	1.7	90 and over.....	4	118	267	900	100.0	99.7
18.....	12	3	165	20	61.8	2.0	Unknown.....		3	267	903	100.0	100.0

¹ Exclusive of—

Bulb sutures.....	OS	ZI
Secondary or tertiary operations.....	2	24
Primary after graft.....	10	27
Total.....	12	52

NOTE.—This table on sciatic nerve injuries shows approximately the same pattern of relationship between OS and ZI cases as was observed for all nerves combined (table 7(a), app. E). Most of the OS cases (86 percent) received the first attempt at surgical repair within 3 months after injury; during the same period, operations were performed on only 13.5 percent of the ZI group. As in all nerves combined, the majority of the ZI cases (52.2 percent) received first definitive treatment during the 3-month interval from the 4th through the 6th month after injury.

TABLE 8.—Operative procedure, end-to-end anastomosis (total cases)¹

End-to-end anastomosis	Number of cases			Percentage of total reported		
	OS	ZI	Total	OS	ZI	Total
Complete.....	214	744	958	81.1	80.4	80.6
Partial.....	50	181	231	18.9	19.6	19.4
Information unavailable.....	12		12			
With tantalum wire.....	205	540	745	82.3	58.7	63.8
With other suture material.....	39	297	336	15.7	32.3	28.7
With tantalum wire and other suture material.....	5	83	88	2.0	9.0	7.5
No entry or information unavailable ²	27	5	32			
With stay suture.....	105	202	307	52.8	22.0	27.5
Without stay suture.....	94	715	809	47.2	78.0	72.5
Information unavailable.....	77	8	85			
Wrapped in tantalum foil.....	169	311	480	98.8	98.7	98.8
Wrapped in other cuff material.....	2	4	6	1.2	1.3	1.2
No entry or information unavailable.....	105	610	715			
With mobilization.....	154	798	952	99.4	97.9	98.2
With transplantation.....		4	4		.5	.4
With mobilization and transplantation.....	1	13	14	.6	1.6	1.4
No entry or information unavailable.....	121	110	231			
Bone resection.....		1	1			
No entry or information unavailable.....	276	924	1,200			

¹ Excluding all bulb sutures.

² "No entry" signifies items were left blank; "information unavailable" signifies that the reporting hospital lacked information on the items.

TABLE 9.—Rate of advance of Tinel's sign, by interval after operation (total cases)

Tinel's sign (in cm.)	Interval after operation to assessment (in months)													Total
	0-1.9	2-2.9	3-3.9	4-4.9	5-5.9	6-6.9	7-7.9	8-8.9	9-9.9	10-10.9	11-11.9	12-12.9	13+	
0.....	18	21	56	9	6	5	4	3	1	3	2		2	130
0.1-2.9.....	3	4	2		1									10
3.0-5.9.....	3	7	23	5	2	4								44
6.0-8.9.....	1	9	26	2	2	2								42
9.0-11.9.....	1	11	21	8	2	3			1				1	48
12.0-14.9.....		2	22	2	5	3	1				1			36
15.0-17.9.....	1	12	20	8	5	3	3	1	1					54
18.0-20.9.....		7	37	7	5	14	4	1	2					77
21.0-23.9.....		4	17		2	1	1		1				1	27
24.0-26.9.....	1	2	30	7	5	15	3		1		1	2	1	68
27.0-29.9.....		1	14	2	1	5		1	1				1	26
30.0-32.9.....		6	29	7	7	18	9	5	9	2			1	93
33.0-35.9.....		1	6	2	6	12	2	1	4	3	1	1		39
36.0-38.9.....			10	4	1	5	4	1	5	1				31
39.0-41.9.....		1	7	5	6	22	6	6	8	5	2	3	2	73
42.0-44.9.....			3	1	2	6	2	1	4	1				20
45.0-59.9.....		2	16	7	8	61	12	18	26	4	6	12	15	187
60.0-98.9.....			4	2	3	17	2	8	29	6	5	13	13	102
Complete.....			1	1	1		1		1			1	1	7
Unknown or unreported.....		1	3	1	1	3			2					11
Total assessments.....	28	91	347	80	71	199	54	46	96	25	18	32	38	1,125
Average advance.....	7.8	16.2	22.6	27.0	30.9	41.1	38.0	50.3	53.5	51.7	54.2	60.3	57.7	35.0

NOTE.—This table shows all sciatic assessments distributed by the interval between operation and assessment, with the assessments in each interval broken down by the extent of advance of Tinel's sign. For each time interval, the average advance of the sign is shown at the bottom of the table. Cases reporting Tinel's sign as "none," "unknown," or "complete" were excluded from the calculation of these average figures.

In almost every interval the sciatic cases show a greater average advance than do all nerves combined (table 9, app. E). However, this difference is readily explained by the comparatively great length of the sciatic nerve and the consequent higher probability of long advances. The resultant weighing in the high advance groups would necessarily cause the calculated average to be higher than for the combined nerves. (Compare line 60.0-98.9 on table 9, app. E, with line 60.0-98.9 above.)

TABLE 9(a).—Rate of advance of Tinel's sign, by interval after operation (OS cases)

Tinel's sign (in cm.)	Interval after operation to assessment (in months)													Total
	0-1.9	2-2.9	3-3.9	4-4.9	5-5.9	6-6.9	7-7.9	8-8.9	9-9.9	10-10.9	11-11.9	12-12.9	13+	
0.....	7	8	15	4	3			1		1				39
0.1-2.9.....	3	2			1									6
3.0-5.9.....	1	6	6	2	1	1								17
6.0-8.9.....	1	5	9	2	2									19
9.0-11.9.....	1	4	6	2		1								14
12.0-14.9.....		1	7	1	4	2	1							16
15.0-17.9.....	1	5	6		2	3	3							20
18.0-12.9.....		3	13	2	2	4	2	1	2					29
21.0-23.9.....		2	1		2		1							6
24.0-26.9.....	1	2	6	2	1	6	3							21
27.0-29.9.....			1			2								3
30.0-32.9.....		5	3	5	2	5	6	3	5	2				36
33.0-35.9.....		1	1	1	2	5	1	1	3	1	1	1		18
36.0-38.9.....			2	1		1	1			1				6
39.0-41.9.....		1	1	1	1	7	5	4	3	3	1	3		30
42.0-44.9.....			1	1	1	3	1	1	1	1				10
45.0-59.9.....		1	3	1	2	19	4	7	7	1	3	6	5	59
60.0-98.9.....			1	1	1	2	2	1	16	2	2	6	4	38
Complete.....				1	1				1					3
Unknown or unreported.....			2			1			1					4
Total assessments.....	15	46	84	27	28	62	30	19	39	12	7	16	9	394
Average advance.....	8.6	17.0	19.9	27.0	25.8	38.0	35.9	44.5	56.9	46.5	55.9	59.3	64.9	34.5

TABLE 9(b).—Rate of advance of Tinel's sign, by interval after operation (ZI cases)

Tinel's sign (in cm.)	Interval after operation to assessment (in months)													Total
	0-1.9	2-2.9	3-3.9	4-4.9	5-5.9	6-6.9	7-7.9	8-8.9	9-9.9	10-10.9	11-11.9	12-12.9	13+	
0.....	11	13	41	5	3	5	4	2	1	2	2		2	91
0.1-2.9.....		2	2											4
3.0-5.9.....	2	1	17	3	1	3								27
6.0-8.9.....		4	17			2								23
9.0-11.9.....		7	15	6	2	2		1					1	34
12.0-14.9.....		1	15	1	1	1					1			20
15.0-17.9.....		7	14	8	3			1	1					34
18.0-20.9.....		4	24	5	3	10	2							48
21.0-23.9.....		2	16			1			1				1	21
24.0-26.9.....			24	5	4	9			1		1	2	1	47
27.0-29.9.....		1	13	2	1	3		1	1				1	23
30.0-32.9.....		1	26	2	5	13	3	2	4				1	57
33.0-35.9.....			5	1	4	7	1		1	2				21
36.0-38.9.....			8	3	1	4	3	1	5					25
39.0-41.9.....			6	4	5	15	1	2	5	2	1		2	43
42.0-44.9.....			2		1	3	1		3					10
45.0-59.9.....		1	13	6	6	42	8	11	19	3	3	6	10	128
60.0-98.9.....			3	1	2	15		7	13	4	3	7	9	64
Complete.....			1				1					1	1	4
Unknown or unreported.....		1	1	1	1	2			1					7
Total assessments.....	13	45	263	53	43	137	24	27	57	13	11	16	29	731
Average advance.....	4.5	15.3	23.4	27.0	34.1	42.6	41.3	54.4	51.2	56.9	52.8	61.5	55.4	35.3

TABLE 10.—Rate of motor recovery, by interval after operation (total cases)

Motor recovery code	Interval after operation to assessment (in months)													Total
	0-1.9	2-2.9	3-3.9	4-4.9	5-5.9	6-6.9	7-7.9	8-8.9	9-9.9	10-10.9	11-11.9	12-12.9	13+	
0.....	27	85	305	58	55	147	39	33	61	11	8	16	15	860
1.....	1	6	25	16	8	30	12	6	21	6	8	9	11	159
2.....			15	4	5	21	3	4	8	7	2	7	12	88
3.....			2	1	3	1		2	5	1				15
4.....				1				1	1					3
Total assessments.....	28	91	347	80	71	199	54	46	96	25	18	32	38	1,125

TABLE 10(a).—Rate of motor recovery, by interval after operation (OS cases)

Motor recovery code	Interval after operation to assessment (in months)													Total
	0-1.9	2-2.9	3-3.9	4-4.9	5-5.9	6-6.9	7-7.9	8-8.9	9-9.9	10-10.9	11-11.9	12-12.9	13+	
0.....	14	42	70	16	21	40	22	14	21	8	4	10	2	284
1.....	1	4	6	6	3	12	7	1	10	2	2	4	2	60
2.....			7	3	2	10	1	3	4	2	1	2	5	40
3.....			1	1	2			1	3					8
4.....				1					1					2
Total assessments.....	15	46	84	27	28	62	30	19	39	12	7	16	9	394

TABLE 10(b).—Rate of motor recovery, by interval after operation (ZI cases)

Motor recovery code	Interval after operation to assessment (in months)													Total
	0-1.9	2-2.9	3-3.9	4-4.9	5-5.9	6-6.9	7-7.9	8-8.9	9-9.9	10-10.9	11-11.9	12-12.9	13+	
0.....	13	43	235	42	34	107	17	19	40	3	4	6	13	576
1.....		2	19	10	5	18	5	5	11	4	6	5	9	99
2.....			8	1	3	11	2	1	4	5	1	5	7	48
3.....			1		1	1		1	2	1				7
4.....								1						1
Total assessments.....	13	45	263	53	43	137	24	27	57	13	11	16	29	731

TABLE 11.—Rate of sensory recovery, by interval after operation (total cases)

Sensory recovery code	Interval after operation to assessment (in months)												Total	
	0-1.9	2-2.9	3-3.9	4-4.9	5-5.9	6-6.9	7-7.9	8-8.9	9-9.9	10-10.9	11-11.9	12-12.9		13+
0.....	27	86	329	66	59	150	38	26	51	11	8	12	13	876
1.....	1	2	16	10	7	36	12	12	34	7	5	15	11	168
2.....		3	2	3	3	11	4	5	9	6	2	3	8	59
3.....				1	2	2		3	1	1	3	1	6	20
4.....												1		1
Unknown or unreported.....									1					1
Total assessments.....	28	91	347	80	71	199	54	46	96	25	18	32	38	1,125

TABLE 11(a).—Rate of sensory recovery, by interval after operation (OS cases)

Sensory recovery code	Interval after operation to assessment (in months)												Total	
	0-1.9	2-2.9	3-3.9	4-4.9	5-5.9	6-6.9	7-7.9	8-8.9	9-9.9	10-10.9	11-11.9	12-12.9		13+
0.....	14	42	78	22	23	46	20	10	18	5	3	6	1	288
1.....	1	1	4	3	2	8	7	5	14	5	1	7	3	61
2.....		3	2	1	2	8	3	2	5	2	2	2	3	35
3.....				1	1			2	1		1		2	8
4.....												1		1
Unknown or unreported.....									1					1
Total assessments.....	15	46	84	27	28	62	30	19	39	12	7	16	9	394

TABLE 11(b).—Rate of sensory recovery, by interval after operation (ZI cases)

Sensory recovery code	Interval after operation to assessment (in months)												Total	
	0-1.9	2-2.9	3-3.9	4-4.9	5-5.9	6-6.9	7-7.9	8-8.9	9-9.9	10-10.9	11-11.9	12-12.9		13+
0.....	13	44	251	44	36	104	18	16	33	6	5	6	12	588
1.....		1	12	7	5	28	5	7	20	2	4	8	8	107
2.....				2	1	3	1	3	4	4		1	5	24
3.....					1	2		1		1	2	1	4	12
Total assessments.....	13	45	263	53	43	137	24	27	57	13	11	16	29	731

TABLE 12.—*First appearance of Tinel's sign in operations with assessment, by time after operation (total cases)*

Interval after operation to assessment (months)	With appearance of Tinel's sign ¹			No appearance of Tinel's sign ²
	With previous assessment showing Tinel sign as 0	No previous assessment	Total	
0-1.9		10	10	9
2-2.9		66	66	13
3-3.9	2	277	279	38
4-4.9	2	65	67	6
5-5.9	6	36	42	1
6-6.9	18	63	81	5
7-7.9	7	20	27	2
8-8.9	4	17	21	3
9-9.9	2	16	18	-----
10-10.9	3	3	6	3
11-11.9	1	3	4	2
12-12.9		3	3	-----
13 and over	2	13	15	-----
Total	47	592	639	82

¹ Distributed by first assessment which showed a positive Tinel's sign.

² Distributed by latest assessment received.

NOTE.—Of the 721 sciatic operations on which at least 1 assessment has been received, 639 reported that Tinel's sign had made its appearance, either on the first assessment or on an assessment later than one which had shown the sign as "none" or "unknown." In the table above, these cases were distributed according to the interval between operation and the first report which showed recovery. The remaining 82 operations showed no appearance of Tinel's sign on any assessment; these cases were tabulated by the interval between operation and the latest assessment, so as to show the length of time which had elapsed since operation with no evidence of recovery.

Thus, during the interval 3-3.9 months after operation, 277 cases showed the Tinel present at the time of the first assessment; 2 cases reported it for the first time, after previously reporting it as absent or unknown. During the same period, the most recent reports on 38 operations showed the Tinel still absent.

TABLE 12(a).—*First appearance of Tinel's sign in operations with assessment, by time after operation (OS and ZI)*

Interval after operation to assessment (months)	With appearance of Tinel's sign ¹						No appearance of Tinel's sign ²	
	With previous assessment showing Tinel sign as 0		No previous assessment		Total		OS	ZI
	OS	ZI	OS	ZI	OS	ZI		
0-1.9.....			8	2	8	2	3	6
2-2.9.....			35	31	35	31	5	8
3-3.9.....		2	62	215	62	217	13	25
4-4.9.....	2		20	45	22	45	1	5
5-5.9.....	2	4	15	21	17	25	1	
6-6.9.....	4	14	34	29	38	43		5
7-7.9.....	4	3	11	9	15	12		2
8-8.9.....	2	2	7	10	9	12	1	2
9-9.9.....		2	6	10	6	12		
10-10.9.....	1	2	1	2	2	4	1	2
11-11.9.....		1		3		4		2
12-12.9.....			2	1	2	1		
13 and over.....	1	1	2	11	3	12		
Total.....	16	31	203	389	219	420	25	57

¹ Distributed by first assessment which showed a positive Tinel's sign.

² Distributed by latest assessment received.

NOTE.—This table shows the status of Tinel recovery on all sciatic operations, broken down into OS and ZI groups. Comparison of this table and table 12(a), app. E, reveals that the pattern of relationship between OS and ZI cases of operation on the sciatic nerve is very similar to that observed on all nerves combined. Here again a higher proportion of ZI cases report the presence of the Tinel in the early months after operation, apparently indicating quicker recovery on sciatic cases which were operated on in this country. However, as seen in the note on table 12(a), app. E, the greater irregularity of reports of assessment on OS cases operates to weaken the reliability of such a conclusion.

TABLE 13.—*First evidence of motor recovery in operations with assessment, by time after operation (total cases)*

Interval after operation to assessment (months)	With evidence of recovery ¹			No evidence of recovery ²
	With previous assessment showing recovery as 0	No previous assessment	Total	
0-1.9.....		1	1	16
2-2.9.....		5	5	49
3-3.9.....		18	18	187
4-4.9.....		14	14	37
5-5.9.....	3	8	11	41
6-6.9.....	24	23	47	96
7-7.9.....	7	7	14	24
8-8.9.....	5	8	13	16
9-9.9.....	22	9	31	34
10-10.9.....	9	1	10	6
11-11.9.....	3	3	6	8
12-12.9.....	6	2	8	8
13 and over.....	4	11	15	6
Total.....	83	110	193	528

¹ Distributed by first assessment reporting evidence of recovery.

² Distributed by latest assessment received.

NOTE.—Using a procedure similar to that used in table 12, all sciatic operations were divided into 2 groups: Those on which recovery of motor function was reported, with distribution by the interval between operation and the first assessment showing recovery; and those on which no motor recovery was ever reported, distributed by the interval between operation and the latest assessment received.

Thus, at each interval, the status of reporting cases in respect to motor recovery can be read. For example, during the 4th month after operation (3-3.9 months) 18 cases reported for the first time that motor recovery was noted; in this instance all reports were first assessments received on the operations. In the same period, the last assessments received on 187 cases reported that no motor function was or had been recorded since the operation.

TABLE 13(a).—*First evidence of motor recovery in operations with assessment, by time after operation (OS and ZI)*

Interval after operation to assessment (months)	With evidence of recovery ¹						No evidence of recovery ²	
	With previous assessment showing recovery as 0		No previous assessment		Total			
	OS	ZI	OS	ZI	OS	ZI	OS	ZI
0-1.9.....			1		1		6	10
2-2.9.....			4	1	4	1	24	25
3-3.9.....			6	12	6	12	45	142
4-4.9.....			5	9	5	9	8	29
5-5.9.....	1	2	3	5	4	7	14	27
6-6.9.....	5	19	11	12	16	31	22	74
7-7.9.....	3	4	5	2	8	6	14	10
8-8.9.....	3	2	2	6	5	8	8	8
9-9.9.....	10	12	6	3	16	15	11	23
10-10.9.....	5	4		1	5	5	3	3
11-11.9.....	1	2		3	1	5	3	5
12-12.9.....	4	2	1	1	5	3	4	4
13 and over.....	3	1	2	9	5	10	1	5
Total.....	35	48	46	64	81	112	163	365

¹ Distributed by first assessment reporting evidence of recovery.

² Distributed by latest assessment received.

NOTE.—This table is based on the same data shown in table 13, with an additional breakdown of each column into OS and ZI cases.

The comparison of the distribution of the OS and ZI cases here is subject to the same weaknesses of the basic data which were brought out in table 13(a), app. E. (See table 13(a): Note.)

TABLE 14.—*First evidence of sensory recovery in operations with assessment, by time after operation (total cases)*

Interval after operation to assessment (months)	With evidence of recovery ¹			No. evidence of recovery ²
	With previous assessment showing recovery as 0	No previous assessment	Total	
0-1.9.....		1	1	15
2-2.9.....		6	6	50
3-3.9.....		42	42	174
4-4.9.....		21	21	34
5-5.9.....	5	9	14	34
6-6.9.....	18	21	39	94
7-7.9.....	6	6	12	24
8-8.9.....	4	6	10	23
9-9.9.....	15	3	18	37
10-10.9.....	4	2	6	8
11-11.9.....	5	3	8	8
12-12.9.....	8	1	9	12
13 and over.....	6	8	14	8
Total.....	71	129	200	521

¹ Distributed by first assessment reporting evidence of recovery.

² Distributed by latest assessment received.

NOTE.—The data on sensory recovery after sciatic operations was handled and tabulated in the same manner as the data on motor recovery. For the explanation of data and procedure see note on table 13.

TABLE 14(a).—*First evidence of sensory recovery in operations with assessment, by time after operation (OS and ZI)*

Interval after operation to assessment (month)	With evidence of recovery ¹						No evidence of recovery ²	
	With previous assessment showing recovery as 0		No previous assessment		Total		OS	ZI
	OS	ZI	OS	ZI	OS	ZI		
0-1.9.....			1		1		6	9
2-2.9.....			4	2	4	2	25	25
3-3.9.....			14	28	14	28	41	133
4-4.9.....			10	11	10	11	6	28
5-5.9.....	2	3	4	5	6	8	11	23
6-6.9.....	6	12	13	8	19	20	20	74
7-7.9.....	2	4	4	2	6	6	13	11
8-8.9.....	2	2	2	4	4	6	10	13
9-9.9.....	7	8	1	2	8	10	11	26
10-10.9.....	1	3		2	1	5	6	2
11-11.9.....	1	4		3	1	7	4	4
12-12.9.....	3	5		1	3	6	7	5
13 and over.....	3	3	2	6	5	9	2	6
Total.....	27	44	55	74	82	118	162	359

¹ Distributed by first assessment reporting evidence of recovery.

² Distributed by latest assessment received.

NOTE.—The above table shows the data of table 14 with each of the columns in this table divided to show OS and ZI cases separately.

Comparisons between the 2 groups of cases are open to the same objections which were raised in the note on table 14(a), app. E.

INDEX

- abdomen, wounds of, 19, 21, 25, 29, 30, 36, 48, 120, 146, 147
 as cause of death in—
 acute spinal cord injuries, 64
 meningitis, 65
 in World War I, 3, 4
- Abduction, absence of, in ulnar nerve paralysis, 252
- Abduction paralysis, of vocal cord, 448
- Abductor—
 digiti quinti, 337
 hallucis, 352
 pollicis brevis, 328
 pollicis longus, 320, 326, 406, 574
 spasm in paraplegia, 407
- Abscess, diagnostic confusion of brachial aneurysm with, 454
- Abscess formation, in epididymitis, 113
- Accessory nerves, as cause of causalgia after peripheral nerve injuries, 474
- Accidents, as cause of paraplegia, 127-128
- Acetabulum, fracture of, 426
- Acetic acid, in decubitus ulcers, 137
- Acetylcholine drugs, in cord bladder, 94
- Acromion process, 318
- Acromion, transplantation of biceps and triceps heads to, 571-572
- Acute spinal cord injuries, 3-191
 adjunct therapy in, 32, 36, 63
 antibiotic therapy in, 29, 39
 antimicrobial therapy in, 32, 48, 56
 bone fragments in, 42, 44-47
 calculus formation after, 101
 care of gastrointestinal tract in, 63
 causes of death in, 115, 116
 chemotherapy in, 29, 32
 concomitant wounds in, 36, 120, 146
 decubitus ulcers in, 61
 debridement in, 42-43, 50
 diagnosis of, 26, 36-40
 effect of level of, on bladder status, 117-118
 evacuation in, 26, 47-49, 63-64
 factors of mortality in, 64-65
 foreign bodies in, 44-47
 genitourinary complications in, 101-114
 hyperesthesia in, 50
 in ETOUSA, 25-30
 in female, 118-119
 in MTOUSA, 19-23
 laminectomy in, 9, 25, 27, 33, 41-57
- Acute spinal cord injuries—Continued
 loss of sensation in, 169
 lumbar puncture in, 38-39
 management of, 31-65
 meningitis in, 39, 43
 neurologic examination in, 36-38
 nursing care in, 23
 nutritional status in, 63
 orthopedic care in, 22
 pain after, 36, 178-184
 physiologic pathology in, 169-170
 plasma transfusion in, 36
 priority of evacuation in, 26
 prognosis in, 26-27, 33, 37, 46, 47, 55
 prophylactic antimicrobial therapy in, 22
 pulmonary complications in, 32
 records in, 38
 renal infection after, 101-104
 respiratory depression in, 50, 58
 resuscitation in, 35, 36, 39
 roentgenologic examination in, 37, 39-40, 45, 46, 47
 root pain in, 47, 49
 sedation in, 36
 shock in, 36, 39, 64
 signs in, 37-38
 skin changes in, 38
 statistics of, 31-32, 64-65
 status of sex organs after, 101
 suppression of reflexes after, 74
 surgery in, 25-27, 33, 41-57
 symptoms of, 36-37
 transfusion in, 36
 transportability in, 47-49
 transportation in, 35, 47-49
 upper urinary tract function after, 100-101
 urinary tract infection after, 70
 urologic complications in, 22, 32, 101-119
 urologic management in, 22, 36, 61-63, 119-125
 vasomotor changes in, 38
See also Paraplegia, Spine, injuries of.
- Adductor—
 magnus, 351, 410
 pollicis, 357, 401
 spasm in paraplegia, 180, 183
- Adjunct nutritional measures, in paraplegia, 150-151
- Adjunct therapy—
 after laminectomy, 57

- Adjunct therapy—Continued
 during spinal operations, 51
 in acute spinal cord injuries, 32, 36, 63
 in combined bone-nerve injuries, 415-416, 421
See also Blood replacement, Fluid balance, Replacement therapy, etc.
- Adjutant General, 17
 Adjutant General's Office, 128
 Administrative considerations, in—
 early laminectomy, 47-49
 physical therapy, in peripheral nerve injuries, 557
 Administrative policies, in paraplegia, 5-8
 Adrenalin, 50
Aerobacter aerogenes renal infections, in paraplegia, 102-103
 Age factor, in survival, in paraplegia, 12-13n
 Age incidence, in paraplegia, 128
 Air conditioning, in paraplegic centers, 8, 9, 17
 Air evacuation, in—
 acute spinal injuries, 35
 ETOUSA, 120
 paraplegia, 64, 120, 132, 134
 peripheral nerve injuries, 249
 Air mattresses, 8, 29, 58
 Air myelography, 193
 ALBRIGHT, F., 94, 110, 121
 ALBRITTEN, F. F., Jr., 406
 Albumin-globulin ration, in paraplegia, 145, 149
 Alcoholic injections, for segmental pain, in paraplegia, 180-181
 Alcoholism, as contraindication to work furlough, in peripheral nerve injuries, 223
Alkaligenes fecalis renal infections, in paraplegia, 103
 Alpha hemolytic streptococcal infection, in paraplegia, 72
 ALYEA, E. P., 104
 Ambulation:
 in paraplegia, 5-6, 10, 15-16, 86, 87, 95, 110, 124, 139, 147, 153, 163, 164-173, 176, 179
 in prevention of renal calculi, in paraplegia, 108, 110
 relation of, to—
 emotional status, 160
 level of cord injury, 165
 results of instruction in, 172-173, 176, 178
 techniques of, 170-173
 American Red Cross, 22, 122, 187, 190, 191
 Amigen, 151
 Amino acids, in renal infection, 103
 Aminoids, 151
 Amobarbital sodium. *See* Amytal sodium.
 Amputated limbs, procurement of nerve grafts from, 494, 546
 Amputation:
 associated with spinal cord injuries, 181
 causalgia after, 476-477, 478
 in paraplegia, 183-184
 Amyloidosis, in paraplegia, 12n
 Amytal sodium, before laminectomy, 49
 Analgesia, in etiology of decubitus ulcers, 132
 Anatomy, of—
 axillary nerve, 317
 brachial plexus, 305-311, 391
 common peroneal nerve, 353, 361-362
 femoral nerve, 313-346, 347, 349
 median nerve, 328, 397, 398
 musculocutaneous nerve, 313-314, 393-394
 neck, 441
 obturator nerve, 407
 peripheral nerves, 207
 peroneal nerve, 407, 409-410, 581
 posterior tibial nerve, 352-353
 radial nerve, 318-321, 404-405, 573
 sciatic nerve, 350-353, 407, 409-410
 tibial nerve, 351-353
 ulnar nerve, 335-337, 401
See also Surface anatomy.
 Anastomotic vessels, about elbow, 340
 Anatomic approaches, to peripheral nerves, 301-362
See also Incision.
 Anconeus, 320-323
 Anemia in paraplegia, 11
 Anesthesia:
 after acute spinal injuries, 37, 50
 after perineal nerve injuries, 223
 sweat tests in, 279
 after ulnar nerve injuries, 340
 combined with anhydrosis, after nerve block, in peripheral nerve injuries, 277
 for combined nerve-plastic surgery, 422, 430
 for laminectomy, 31, 49-51
 for peripheral nerve surgery, 249, 368-369
 for sciatic nerve surgery, 408
 for vascular-cranial nerve surgery, 448
 maximum area of, in peripheral nerve injuries, 267
 of foot, in irreparable nerve injuries, 580
 of skin, in posterior tibial nerve injuries, 412
 zones of, after spinal cord injury, 51

- Aneurysms:
 associated with—
 bone-nerve injuries, 466
 brachial plexus injuries, 392
 peripheral nerve injuries, 304, 439, 448, 454, 458, 464-465
 peripheral nerve-soft tissue injuries, 467
 peripheral nerve-vascular injuries, 441
 erosion of peripheral nerve by, 519, 528-530
 in paraplegia, 146
 of aorta, 458
 of brachial artery, 395
 of subgluteal artery, 409
 rupture of, 464
 Aneurysmorrhaphy, 442
 anhydrosis, after nerve block, 277
 Ankle:
 frozen joint in, 246
 fusion operations on, 580
 Ankylosis—
 after prolonged immobilization of upper extremity, 584
 in combined bone-nerve injuries, 415, 423
 in combined sciatic nerve-knee injuries, 426
 in combined vascular-nerve injuries, 280
 in peripheral nerve injuries, 558, 563, 565
 in preventing nerve suture, 496
 Annular ligament, 342
 Annulus fibrosus, rupture of, 193
 Anomalous innervation of leg, 490
 Anoxia—
 during dissection of ulnar nerve, 401
 in paraplegia, 12, 146
 Antecubital fossa, 325, 331
 Antecubital space, 340
 Anterior annular ligament, 328
 Anterior condyloid foramen, 441
 Anterior femoral cutaneous nerve, 344
 Anterior horn motor cells, 178
 Anterior rhizotomy, 9
 Anterior tibial artery, 352, 353, 362
 Antibiotic therapy, in—
 combined radial nerve-humerus injuries, 403
 peripheral nerve injuries, 364, 367
 urinary track infection, 103-104, 124
 Antimicrobial therapy—
 after laminectomy, 58
 in acute spinal cord injuries, 29, 32, 35, 48, 56
 in combined bone-peripheral nerve injuries, 245, 250
 Antimicrobial therapy—Continued
 in cord bladder, 117
 in epididymitis, 113
 in periurethral abscess, 113
 Anuria, after sulfonamide therapy, 104
 Aorta, aneurysm of, 458
 Arachnoiditis, 178
 Areflexia, in acute spinal cord injuries, 37
 Arm:
 causalgia in, 478, 490
 combined bone-nerve injuries in, 422-423
 exposure of—
 median nerve in, 330-333
 radial nerve in, 322-325
 ulnar nerve in, 339-340
 Armed Forces Institute of Pathology, 221
 Army Air Forces, 134
 paraplegia in, 128
 Army educational program, 185
 Army followup, of peripheral nerve grafts, 219n
 Army General Classification Tests, rating of paraplegics in, 129, 160, 186
 Army general hospital system, paraplegics in, 5
 Army Ground Forces, paraplegia in, 128
 Army Institute of Pathology, 221
 Army Medical Museum, 221
 Army Service Forces:
 Circular No. 244, 28 June 1945—224
 paraplegia in, 128
 Arterial tubes, in peripheral nerve repair, 389
 Arteriovenous aneurysms—
 associated with peripheral nerve injuries, 442, 464-465
 of upper extremity, 448
 in paraplegia, 146
 Arteriovenous fistulas, 304, 440, 466, 467
 Arthrodesis—
 after tibialis posticus transplantation, 582
 in subastragalar region, 584
 of elbow, 571
 of interphalangeal joints, 579
 of shoulder joint, 318, 571, 572
 Arthroplasty, in combined—
 bone-peripheral nerve injuries of forearm, 423
 sciatic nerve-acetabular injuries, 426
 Arthrotomy, in combined bone-peripheral nerve injuries, 426
 Articularis genus (subcrureus), 345
 Artificial fever therapy, in causalgia, 487
 Ascending infection, in vesical calculi, 112

- Ascending route, of renal infection, 102
 ASSAKY, G., 381
 Assessments, of motor power, in peripheral nerve injuries, 251-252
 Assessments, of peripheral nerve regeneration, in Peripheral Nerve Registry, 226-230
 Assignment, of neurosurgical personnel, 241
 Associated injuries. *See* injuries of specific structures.
Atlas of Peripheral Nerve Injuries, 463n
 Atonic neurogenic bladder. *See* Cord bladder.
 Atonic stage, of cord bladder, 79, 86
 Atropine sulfate:
 before laminectomy, 49
 in cord bladder, 94
 preoperative administration of, in peripheral nerve surgery, 368
 Atrophy, in—
 peripheral nerve injuries, 565
 ulnar nerve injuries, 400
 Attu, 188
 Auscultation, in combined peripheral nerve-vascular injuries, 440
 Austrian management, of cord bladder, in World War I, 119
 Autogenous nerve grafts, 219, 381, 494-499, 509
 Autogenous skin solution, in decubitus ulcers, 138
 Autografting, of small nerves, 219
 Autografts. *See* Autogenous nerve grafts.
 Automobiles, for paraplegics, 173
 Autonomic nervous system, 169
 Autonomous area, in peripheral nerve injuries, 224, 268, 405
 Autonomous bladder. *See* Reflex automatic bladder.
 Autonomous zone in causalgia, pain in, 479
 AVELLIS, G., 441
 Avulsed wounds, of brachial plexus, 391
 Avulsion injuries, involving peripheral nerves, 236
 Axilla:
 exposure of ulnar nerve in, 338
 repair of radial nerve injuries in, 322, 401-402
 Axillary aneurysms, 448
 Axillary artery, 308, 310, 311, 317, 318, 320, 322, 338, 392
 Axillary nerve:
 anatomy of, 313
 exposure of, 317-318
 Axillary nerve—Continued
 orthopedic surgery for repair of, 317-318, 393, 572-573
 study of specimens from, 514
 surface anatomy of, 317
 techniques of gaining length in, 318
 Axillary vein, 308, 322
 Axon splitting, in median nerve injuries, 397
 Axonotmesis, 559
 Azochloramid, in decubitus ulcers, 137, 138
Bacillus cloacae infections, in paraplegia, 103
Bacillus coli infections, in experimental paraplegia, 73
 Back, wounds of, 36
 Bacteriology, of—
 bladder infections, in paraplegia, 72, 73
 decubitus ulcers, 131
 infection, in paraplegia, 12
 renal infection, in paraplegia, 102-103
 BADAL, D., 72
 BAILEY, M. K., 95
 Balanced skeletal traction, in combined bone-nerve injuries, 245, 250
 Balanitis, 62
 Balkan frames, 9
 BALLANCE, C., 493
 BALLINGALL, G., 302
 Balsam of Peru, in decubitus ulcers, 137
 Barbiturates:
 after laminectomy, 57
 contraindications to, in acute spinal injuries, 49
 preoperative administration of, in peripheral nerve surgery, 368
 BARKER, Maj. D. E., 9, 131, 140, 142, 145
 BARR, J. S., 193
 Basilic vein, 330
 Battalion aid stations:
 acute spinal cord injuries in, 36
 management of cord bladder in, 61
 BAUDENS, 303
 Beds, for paraplegics, 8
 BELLIS, J. C., 93
 BENISTY, A., 207, 303
 BESLEY, F. A., 88
 Biceps, 314, 322, 323, 326, 330, 335, 338, 394, 395, 404, 423
 brachii, 328
 femoris, 343, 351, 410
 tendon, 325, 331, 362
 transplantation of short head of, to acromion, 571-572
 Bicipital tubercle, of radius, 331

- Biliary fistula, in paraplegia, 146
- BILLROTH: T., 302
- Bipolar intraneural stimulation, 266
- Bladder:
- capacity, in paraplegia, 70, 74-79, 116
See also Cystometry.
 - complications, of cord bladder, 111-112
 - drainage of—
 - after laminectomy, 58
 - during laminectomy, 51
 - function, in—
 - acute spinal cord injuries, 37
 - paraplegia, 6, 13, 18, 151-153
 - irrigations, in—
 - catheter drainage, of cord bladder, 99
 - catheter management, of cord bladder, 91, 99
 - renal infection, 104
 - suprapubic cystostomy, 95
 - neck:
 - in cord bladder, 79, 80-81, 83-86, 91
 - resection of, 97-98, 99, 117, 122, 124, 125
 - physiology of, 80
 - pressure, in paraplegia, 77-79
 - status, effect of level of cord injury on, 117-118
 - training, in paraplegia, 98, 122
 - wall:
 - fibrosis of, 95
 - infection of, 71
 - trabeculation of, 79, 80
- See also* Cord bladder, Reflex automatic bladder, Urologic, Vesical, etc.
- Blisters, in causalgia, 473n
- Blood chemical studies, in paraplegia, 124, 129
- Blood cultures, in urinary tract infections, 102, 146
- Blood replacement—
- after laminectomy, 57
 - during laminectomy, 51
 - in acute spinal cord injuries, 36, 63
 - in combined bone-peripheral nerve injuries, 421
 - in combined peripheral nerve-vascular injuries, 440
 - in decubitus ulcers, 140
 - in paraplegia, 150, 175
 - in renal infections, 103
- Blood serum, applications of, in decubitus ulcers, 144
- Blood studies, in paraplegia, 129, 149, 150
- Blood supply:
- in decubitus ulcers, 136
 - in peripheral nerve injuries, 304
 - protection of, at sciatic nerve repair, 410
- Bodian Protargol technique, 514, 515, 518
- Bone chips, in combined bone-peripheral nerve surgery, 422
- Bone fragments:
- in cauda equina injuries, 181
 - in spinal cord injuries, 26, 31, 33, 35, 38, 42, 44-47
 - management of, at laminectomy, 52-54
 - roentgenologic demonstration of, in acute spinal cord injuries, 39, 40
- Bone grafting, 404, 416, 420
- Bone grafts, in—
- combined bone-peripheral nerve injuries, 422, 428
 - combined sciatic nerve-femoral injuries, 425
 - fusion operations on thumb, 571
 - irreparable median nerve injuries, 577
- Bone injuries, associated with:
- incomplete peripheral nerve injuries, 519, 521, 543
 - peripheral nerve injuries, 211-212, 232, 235, 238, 244-246, 304, 364, 367, 414-428, 519, 521, 543, 558
 - in World War I, 208
 - orthopedic techniques in, 569-570
 - role of, in peripheral nerve injuries, 519, 521
 - shortening of bone in, 236, 249, 305, 380, 496
- Bone-peripheral nerve-vascular injuries, 222
- Bone-radial nerve injuries, 564
- Bone Tumor Registry, 225
- Boobytraps, 399
- Boric acid—
- applications, in decubitus ulcers, 137, 140
 - solutions, for bladder irrigation, 94
- BORS, Maj. E. H. J., 176, 187
- BOWDEN, R. E. M., 364
- Bowel function, in paraplegia, 6, 13, 151, 153-157
- BOWIE, Maj. C. F., 104, 112
- BOYD, M. L., 95
- Braces—
- after peripheral nerve suture, 237
 - in irreparable peripheral nerve injuries of lower extremity, 580
 - in paraplegia, 10, 13, 116, 162, 165, 167-168, 176, 177
 - in peroneal nerve injuries, 581

- Braceshops, in paraplegic centers, 14
- Brachial artery, 318, 320, 321, 323, 330, 331, 335, 337, 338, 398
 protection of, at median nerve surgery, 395
- Brachial plexus, 322
 anatomy of, 305-311, 391
 branches, from—
 nerve roots of, 310
 trunks of, 310
 components of, 305-308
 cords of, 310, 311, 316, 317, 318, 322, 335, 392
 division of clavicle in injuries of, 313
 formation of, 305-308, 310-311, 335
 formation of median nerve, from cords of, 328
 injuries of, 249, 303-313
 associated with aneurysms, 448
 closure of wound in, 313
 exposure in, 311-313
 neurolysis in, 391, 392
 pathologic process in, 391
 positioning at operation for, 311, 313, 378, 391
 repair of, 391-393
 shortening of clavicle in, 305
 study of specimens from, 514
 techniques of gaining length in, 313
 nerve block, 369
 physiology of, 308, 311
 relations of, 308-310
 relations of axillary nerve to, 317
 roots of, 305-306, 311
 surface anatomy of, 311
 surgical approach to injuries of, 311-313
 trunks of, 311
 veins, 323, 338
- Brachialis, 314, 320, 325, 326, 331, 394, 404, 423
- Brachioradialis, 320, 321, 325, 326, 331, 403, 404, 406
 involvement of, in radial nerve injury, 256
 nerve, compensatory function of, 394
- Branches—
 from brachial plexus cords, 310
 from nerve roots forming brachial plexus, 308-310
 from trunks of brachial plexus, 310
 of femoral nerve, 344-346
 of posterior tibial nerve, 352-353
 of radial nerve, 320, 321
 of sciatic nerve in thigh, 351
 of service, paraplegia in, 128
 of tibial nerve, 351-352
- Branches—Continued
 of ulnar nerve, 335-337
- BRIDGERS, W. H., 93
- BRISTOW, W. R., 207, 303, 305
- British civilian personnel, use of, in physical therapy, 246
- British experience, in peripheral nerve injuries, in World War I, 207
British Journal of Surgery, 207
- British management, of—
 cord bladder, in World War I, 89, 119
 peripheral nerve injuries, 239
- British neurosurgical centers, 469
- BROCK, S., 89
- Bronchoscopic suction, after laminectomy, 58
- Brown-Séguard incomplete spinal cord lesions, 22-24
- Bulb sutures, in peripheral nerve injuries, 519, 533, 543
- Bulbous urethra, in cord bladder, 82
- BUMPUS, H. C., 81, 94, 98, 117
- BUNNELL, S., 4, 5, 303, 304, 326, 289, 493, 566, 577
- Bureau of War Risk Insurance, 209
- Burma, 473n
- BURNE, J., 101
- Burns, 49
- Cable frozen dried homografts, 495
- Cable grafts, in peripheral nerve injuries, 381, 382, 405, 494, 498, 514
- Cable sural autografts, 546, 555
- Cachexia in etiology of decubitus ulcers, 131
- Cadavers, procurement of nerve grafts from, 495-496
- CAHILL, G. F., 89
- Calcification of soft tissues, in paraplegia, 147
- Calcium—
 debris, in cord bladder, 94
 metabolism, disorders of, in paraplegia, 129, 147
- Calculi, in cord bladder, 14, 97, 100, 121, 122
- Calculus formation, in paraplegia, 101, 129, 147, 152-153
- CAMPBELL, Col. F. H., Jr., 231n
- Canadian policies, in herniated nucleus pulposus, 195
- Cantharides, 473n
- Capillary thrombosis, in decubitus ulcers, 131
- Capitellum, of humerus, 325
- Capsulotomy, of toes, 579
- Cardiorespiratory imbalance, in acute spinal cord wounds, 21

- Carotid artery, 441
 CARP, J., 74
 Case fatality rates, in—
 acute spinal cord injuries, 31-32, 65, 115
 in Civil War, 114-115
 in civilian life, 115
 in forward hospitals, 64-65
 in World War I, 3, 31, 114, 115, 119
 combined peripheral nerve-vascular injuries, 439, 442
 cord bladder, 114-115, 117
 in World War I, 114
 incomplete transections of spinal cord, 115
 intermittent catheter drainage, 90
 laminectomy, 65, 181
 paraplegia, 12-13n, 123
 peripheral nerve surgery, 250
 renal infection in paraplegia, 102
See also Statistics.
 Case histories:
 autogenous nerve grafts, 509
 cable sural autografts, of radial nerve, 546-547
 causalgia, in complete nerve injuries, 476-477
 combined bone-peripheral nerve-vascular injuries, 466
 of lower extremity, 455-458
 of upper extremity, 448-454
 combined sciatic nerve-bone injuries, 426
 combined skin-soft tissue-peripheral nerve defects, 432-438
 combined vascular-cranial nerve injuries, 443-447
 common peroneal nerve injuries, 300
 disruption of suture line, in peripheral nerve injuries, 539-541
 erosion, of radial nerve, by axillary aneurysm, 528-531
 failure, of sympathectomy, in causalgia, 487, 487n
 frozen dried homografts, 495-512
 hemilaminectomy, 57
 injury, of tibial and peroneal components, of sciatic nerve, 296-297
 injury, of tibial and peroneal nerves, above popliteal space, 297-300
 laminectomy:
 associated thoracoabdominal and spinal cord injuries, 43
 cerebrospinal fluid fistula, 42-43
 compression, of spinal cord, 45
 hemothorax, 48-49
 Case histories—Continued
 laminectomy—continued
 through-and-through wounds, of spinal canal, 46-47
 wound of cauda equina, root pain, 43-44
 median nerve injury—
 in forearm, 291
 near elbow, 285
 peripheral nerve injury, combined with vascular occlusion, 458-463
 radial nerve injury, above elbow, 294-295
 radial nerve paralysis, 269-270
 rehabilitation, in paraplegia, 187-188
 repair of median nerve, in distal forearm, 399
 sciatic nerve injury, in upper thigh, 296
 successful frozen dried homografts, 500-501
 surgical radial nerve injury, above elbow, 294
 ulnar and median nerve injuries, above elbow, 291-294
 ulnar nerve injury—
 above elbow, 283-287, 289-291
 above wrist, 289
 below elbow, 287-289
 unsuccessful frozen dried homograft, 503
 Caster oil applications, in decubitus ulcers, 137
 Casts—
 after peripheral nerve repair, 244, 246-247
 Catgut sutures, in peripheral nerve surgery, 388-389
 Cathartics, in paraplegia, 153
 Catheter drainage:
 as cause of periurethral abscess, 113, 122
 epididymitis during, 122
 in cord bladder, 122
 in female, 118-119
 in perineal urethrostomy, 97
 management of cord bladder, 89, 90-91
 Catheterization—
 in acute spinal cord injuries, 36, 123
 in World War I, 3, 4, 119
 of ureters, in renal infection, 104
 Cauda equina:
 bladder neck, in complete transection of, 84-85
 bladder pressure, in wounds of, 79
 bone fragments in, 181
 case fatality rates for wounds of, in World War I, 115
 complete transection of, 71

Cauda equina—Continued

- cord bladder, in wounds of, 69, 70, 98, 114, 118
- cystography, in wounds of, 81
- cystometry, in—
 - complete transection of, 82-84
 - incomplete transection of, 77
 - wounds of, 69
- cystoscopy, in wounds of, 79
- decompression of, 44-47
- foreign bodies in, 181
- frozen dried homografts from, 497-509
- laminectomy, in wounds of, 182
- pain, in wounds of, 43-44, 49
- rhizotomy, in wounds of, 182
- sex function, after incomplete transection of, 101, 104
- wounds of, 9, 32, 38, 47, 55, 178

Causalgia:

- after femoral nerve injuries, 349
- after injuries of posterior tibial nerve, 414
- after median nerve injuries, 414
- after peripheral nerve injuries, 178, 208, 219, 231, 303, 469-492
 - clinical picture in, 479-485
 - contractures in, 482
- contraindications to nerve section in, 579
- diagnosis of, 469, 475, 488
- differential diagnosis of, 485-487
- effect of environment on, 470
- effect of malaria in, 487
- emotional stimuli in, 482-485, 486, 488
- environmental stimuli in, 485, 486
- etiology of, 469, 474-478
- followup studies in, 490
- hyperesthesia in, 476, 478, 479, 482
- in Civil War, 478-479
- incidence of, 469, 470-473, 473n
- in special nerves, 475
- malnutrition in, 480
- management of, 487-489
- mechanism of pain in, 475-477
- motor paralysis in, 489
- nerve resection in, 488, 579
- neurolysis in, 487
- osteoporosis in, 477-478, 485
- pain in, 470-473, 473n, 474-475, 476, 478-480, 485-487, 488, 489-490
- papaverine hydrochloride in, 487
- pathologic process in, 473-474, 476
- personality changes in, 482, 485
- physical stimuli in, 485
- preexistent psychogenic factors in, 485

Causalgia—Continued

- after peripheral nerve injuries—continued
 - psychogenic factors in, 482-485, 486, 488
 - recurrence of, 490
 - results in, 489-490
 - roentgenologic examination in, 485
 - section of ulnar nerve in, 576
 - sensory losses in, 482
 - sensory paralysis in, 489
 - skin temperature readings in, 474-475
 - spontaneous recovery in, 470, 473, 477
 - statistics of, 470-473, 473n, 490
 - sympathectomy in, 470, 473n, 475-477, 486-489, 490
 - sympathetic block in, 473n, 476-477, 486-490
 - therapeutic testing in, 486-488
 - trophic changes in, 481
 - vasoconstriction in, 485, 486-487
 - vasomotor changes in, 481, 485
- in paraplegia, 181

Causes of death, in—

- acute spinal cord injuries, 115, 116
- brachial plexus injuries, 392
- combined peripheral nerve-vascular injuries, 442
- femoral nerve injuries, 406
- paraplegia, 11-12, 90
- peripheral nerve surgery, 250

Cavus deformity, 579

Central neuroma, 377

Cephalic vein, 391, 393

Cerebral sensory cortex, 183

Cerebrospinal fluid:

- circulation of, 38
- fistula, 38
 - after laminectomy, 55, 65
 - closure of, 26
 - penicillin therapy in, 58

Cervical laminectomy, 51

Cervical nerves, 312

formation of—

- axillary nerve from, 317
- brachial plexus from, 305-308, 310, 335
- median nerve from, 328
- musculocutaneous nerve from, 314
- radial nerve from, 318-320

Cervical plexus, 312

Cervical spinal cord:

- anesthesia, in wounds of, 50, 51
- case fatality rates, in wounds of, 115
- cord bladder in, 118
- factors of mortality, in wounds of, 64

- Cervical spinal cord—Continued
 priapism, after transection of, 38, 91, 101, 113, 173
 roentgenograms of, 39
 wounds of, 20, 30, 35, 36, 47, 49, 50, 58, 59, 63, 64
 in Civil War, 115
- Cervicodorsal spinal cord, wounds of, 181
- Cervicothoracic spinal cord, wounds of, 19
- Changes of position—
 after laminectomy, 58-59
 during evacuation of paraplegics, 23, 131-135
 in paraplegia, 22, 29, 108, 135
- Chaplain Corps, 122
- Chaplains, in paraplegic program, 190
- Charcot joint, 570
- Charny, C. W., 74
- Chemotherapy, in—
 acute spinal cord injuries, 29, 32, 64
 cord bladder, 62
 renal infection, 103-104
- Chest wall, decubitus ulcers of, 131
- Chest, wounds of, 19, 21, 25, 29, 30, 36, 48, 50, 51, 64, 120, 146
 as cause of death, in acute spinal cord injuries, in World War I, 3, 4
- Chief of Medical Supply, Office of Chief Surgeon, ETOUSA, 29
- Chief Surgical Consultant, OTSG, 195, 225
- Chills, in urinary tract infection, 103, 146
- Chinizarin sweat test, in peripheral nerve injuries, 280
- Chloramine-T, in decubitus ulcers, 137
- Chlorazine, in decubitus ulcers, 138
- Cholinergic drugs, 280n
- Chronaxie determinations, in peripheral nerve injuries, 561
- Churchill, Col. E. D., 231-232
- Cicatricial vascular occlusion, associated with peripheral nerve injuries, 442
- Circular No. 25, ASF:
 22 Jan. 1945-5, 13
 10 Dec. 1945-14
- Circular Letters:
 No. 43, OTSG, 13 Feb. 1943-195
 No. 81, Office of Chief Surgeon, ETOUSA, 10 June 1944-240
 No. 190, OTSG, 17 Nov. 1943-197
- Civil War:
 case fatality rates for acute spinal cord injuries in, 114-115
 causalgia after peripheral nerve injuries in, 219, 473n, 474, 478-479
 498991v-59-46
- Civil War—Continued
 peripheral nerve injuries in, 302-303
 sympathectomy in, 489
- Civilian management, of—
 cord bladder, 67, 98-99
 paraplegia, 127, 146
- Civilian policies, in—
 acute spinal cord injuries, 25
 rehabilitation in paraplegia, 162
- Civilian practice:
 causalgia in, after peripheral nerve injuries, 487n
 spinal cord concussion in, 47
- Civilian results, of surgery for herniated nucleus pulposus, 193-194, 200
- Civilian-type injuries of—
 median nerve in hand, 399
 peripheral nerves, 239, 363-364, 493
 posterior tibial nerve, 412
 spinal cord, 115-116
 ulnar nerve, 576
- Classification, of—
 acute spinal cord injuries, 32-35
 in World War I, 3
 peripheral nerve injuries, 363-364
 recovery stages, of cord bladder, 68-71
 suture sites, in peripheral nerve injuries, 531-533
- Clavicle:
 boundary of posterior cervical triangle by, 308
 division of, in brachial plexus injuries, 313
 overriding of, in brachial plexus surgery, 313
 shortening of, in brachial plexus injuries, 305, 392
- Claw hand, 265, 571, 576-577
- Clawing, of toes, 579
- Clearing stations:
 acute spinal cord injuries in, 36
 management of cord bladder in, 61
- Cleveland, Col. Mather, 246
- Clinical picture, of herniated nucleus pulposus, 193, 196
- Closed drainage, in cord bladder, 122, 123, 124
- Closed injuries, of spine, 20, 23, 35, 38
- Closed system, of irrigation, in cord bladder, 91-92, 99
- Closure, of—
 cerebrospinal fluid fistula, 26
 decubitus ulcers, 139-145, 149, 190
 donor site in combined peripheral nerve-plastic surgery, 431

- Closure, of—Continued
 dura at laminectomy, 55
 incision in brachial plexus injuries, 313
 in femoral nerve injuries, 349
 in musculocutaneous nerve injuries, 316
 in peripheral nerve surgery, 384
 in posterior tibial nerve injuries, 359
 in radial nerve injuries, 323, 325, 326
 in sciatic nerve injuries, 356
 laminectomy wound, 55–56
 suprapubic cystostomy, 176
- Coaptation sutures, at debridement in peripheral nerve injuries, 228, 234, 242
- Cobb, S., 101, 114
- Cobra venom, 180
- Codeine, after laminectomy, 57–58
- Coleman, C. C., 101, 114
- Coli-aerogenes* infection, in paraplegia, 12
- Collagen sleeve technique, in frozen dried homografting, 498, 508
- Collagen tubes, in peripheral nerve repair, 389
- Collagenization, in peripheral nerve injuries, 519, 528, 543
- Collateral circulation, in—
 combined vascular-peripheral nerve injuries, 464
 median nerve injuries, 394
 peripheral nerve injuries, 304
- Collecting stations, acute spinal cord injuries in, 36
- Colony-type paraplegic wards, 9
- Color changes, in combined vascular-peripheral nerve injuries, 440
- Colostomy, in paraplegics, 146, 150
- Combined arterial-peripheral nerve injuries, 439n
- Combined bone-peripheral nerve injuries, 211–212, 222, 235, 238, 242, 244–246, 250, 253, 364, 415–428
 orthopedic techniques in, 569–570
 physical therapy in, 564
 statistics of, 246, 422–428
- Combined bone-peripheral nerve surgery, technique of, 421–422
- Combined bone-peripheral nerve-vascular injuries, 466
- Combined injuries. *See* special combinations.
- Combined median nerve-arterial injuries, 439n
- Combined median nerve-bone injuries, 428
- Combined median nerve-humerus injuries, 423–425
- Combined neurosurgical-orthopedic management of bone-peripheral nerve injuries, 245–246, 250, 367, 380, 415–428
- Combined peripheral nerve-femoral artery injuries, 455
- Combined peripheral nerve injuries, study of footprints and handprints in, 265
- Combined peripheral nerve-jugular vein-carotid artery injuries, 442
- Combined peripheral nerve-popliteal artery injuries, 455
- Combined peripheral nerve-skin injuries, 429–438
- Combined peripheral nerve-skin-soft tissue injuries, 211–212, 364, 564
- Combined peripheral nerve-soft tissue-bone injuries, 569–570
- Combined peripheral nerve-soft tissue-vascular injuries, 467
- Combined peripheral nerve-vascular injuries, 211–212, 222, 237, 238, 243, 253, 280–281, 364, 439–467
 diagnosis in, 440–441
 incidence of, 439–440, 439n
 in neck, 441–448
 prognosis in, 442–443
- Combined peripheral nerve, vascular-bone injuries, 569–570
- Combined peroneal nerve-arterial injuries, 439n
- Combined plastic-neurosurgical management of peripheral nerve injuries, 429–438
- Combined radial nerve-arterial injuries, 439n
- Combined radial nerve-bone injuries, 428
- Combined radial nerve-humerus injuries, 256, 325, 402–404, 422–423, 573
- Combined sciatic nerve-femoral injuries, 425–426, 428
- Combined sciatic nerve-knee injuries, 426
- Combined sciatic-peroneal nerve-arterial injuries, 439n
- Combined sciatic-tibial nerve-arterial injuries, 439n
- Combined tendon-nerve injuries, 253, 398, 401
- Combined tibial nerve-arterial injuries, 439n
- Combined ulnar nerve-arterial injuries, 439n
- Combined ulnar nerve-bone injuries, 428
- Combined ulnar nerve-humerus injuries, 422–423
- Combined ulnar nerve-radius injuries, 423–425
- Combined ulnar nerve-ulna injuries, 423–425

- Combined vascular, cranial nerve injuries, 441-448
- Combined vascular-radial nerve injuries, 402
- Committee on Veterans Medical Problems, National Research Council, 219, 230
- Common flexors of fingers, 335
- Common flexor tendons of fingers, 341
- Common peroneal nerve, 352, 356
 anatomy of, 353, 361-362
 exposure of, 357-362
 formation of, 351, 357
 injuries of, 250, 378-379
 repair of injuries of, 411-412
 stretch fibrosis of, 539
 study of specimens from, 514
 transplantation of, 411
- Common volar digital nerve, 328, 333
- Communicating peroneal nerve, 353
- Compass test, in peripheral nerve injuries, 277-279
- Complete peripheral nerve injuries:
 causalgia in, 476-477
 response to electrical stimulation in, 372
- Complete syndrome, of last four cranial nerves, 442
- Complete transection, of—
 cauda equina, 71, 118
 cystometry in, 82-84
 cystoscopy in, 80-81
 spinal cord:
 at level of conus, 71
 bladder neck in, 84-85
 bladder function in, 87
 case fatality rates in, 115
 cord bladder in, 69, 70-71, 94, 116, 117-118, 123-124
 cystometry in, 76
 in World War I, 3
 priapism after, 38, 91, 101, 113, 173
 renal calculi after, 105-106
- Dakin's solution, in decubitus ulcers, 137, 138
- Danish school of gymnastics, 567
- David, V. C., 73, 89
- Davis, Col. Loyal, 6, 165, 203, 207, 303, 441, 470, 489
- Debilitation, in—
 herniated nucleus pulposus, 203
 paraplegia, 12, 131, 134
- Debridement:
 accidental nerve severance at, 533
 at hemilaminectomy, 56
 at laminectomy, 52-54, 55
- Debridement—Continued
 coaptation sutures at, in peripheral nerve injuries, 234
 in acute spinal cord injuries, 20-21, 25, 42-43, 50
 in combined bone-nerve injuries, 250
 in combined radial nerve-humerus injuries, 403
 in decubitus ulcers, 136, 141-142
 in peripheral nerve injuries, in World War I, 208
 in spinal cord injuries, in World War I, 31
 in wounds of extremities, 208
 management of peripheral nerve injuries at, 233-237, 242-243, 250, 304-305, 364, 376, 403
 primary nerve suture at, 228, 232
- de CHAULIAC, G.
- Decompression—
 in paraplegia, 181
 of spinal cord, 20-21, 54
 of spinal cord and cauda equina, 44, 47
- Decubitus ulcers:
 as cause of death, in paraplegia, 11
 as result of adductor spasms, 180
 associated with renal calculi, 110
 closure of, 139-145, 149, 190
 debridement in, 136
 development of, during transportation, 23, 29, 64, 130-135
 dietary management in, 9
 dressings in, 137-138
 etiology of, 131-134, 147-148
 fluorescein studies in, 136
 healing in, 138-139
 in paraplegia, 6, 9, 10, 13, 22, 29-30, 61, 71, 87, 89, 90, 99, 119, 130-145, 146
 in World War I, 3, 130
 infrared treatment of, 22
 local measures in, 135-138, 140
 management of, 29-30, 135-145
 nitrogen balance in, 139-140
 nursing care in, 145
 nutritional factor in, 63
 of sacral region, 11, 61, 87, 131, 137-138, 139, 142, 143
 over trochanters, 87, 135, 137, 139, 142 •
 pathologic process in, 131
 plastic surgery in, 9, 10, 131, 135
 prevention of—
 after laminectomy, 59
 at operation, 51
 in paraplegia, 6, 134-135, 155

- Decubitus ulcers—Continued
 protein deficit in, 9, 10, 63, 135, 145, 146, 147-150
 recordkeeping in, 135
 renal infection from, 102
 skin grafting in, 135, 143-145, 149, 151
 spontaneous healing of, 10
 statistics of, 22, 137, 142
 surgery in, 10, 18, 138-145
 techniques of surgery in, 141-145
- D-day, 25, 26, 120
- Deep circumflex iliac vessels, 347
- Deep peroneal (anterior tibial) nerve, 353, 361
- Deep pressure sense, in peripheral nerve injuries, testing of, 266-272
- Deep radial nerve, 321
- Definition, of neurosurgical conditions, 25n
- Deformities, in causalgia, after peripheral nerve injuries, 482
- Degenerative changes, in peripheral nerve injuries, 211
- Delayed management of nerve component, in combined bone-nerve injuries, 245
- Delayed primary wound closure, 231
 in combined bone-peripheral nerve injuries, 246, 250
 in combined radial nerve-humerus injuries, 403
 in MTOUSA, 247
 in peripheral nerve injuries, 242, 252, 364, 562, 563
 in soft-tissue wounds, 240
- Deltoid, 317, 318, 321, 322, 325, 391, 393
- Deltoid function, in axillary nerve injuries, 572
- Deltoid paralysis, 571
- Dennis, F. S., 115
- Denny-Brown, D. E., 71, 82, 83, 118
- Depressed fracture, of spine, 40
- Depression, in paraplegia, 17
- Dermometry, 562
- Detrusor, reflex contractions of, 76, 79, 80, 84, 86
- Development, of—
 paraplegic program, 5-18
 policies, in—
 herniated nucleus pulposus, 194-203
 peripheral nerve injuries, 211-230, 231-237, 239-247
- Diagnosis, of—
 acute spinal cord injuries, 26, 36-40
 causalgia, after peripheral nerve injuries, 469, 475, 488
- Diagnosis, of—Continued
 combined peripheral nerve-vascular injuries, 440-441, 454, 465
 epididymitis, 112
 herniated nucleus pulposus, 193
 peripheral nerve injuries, 251-300
 periurethral abscess, 113
 renal calculi, 104, 105-106
 renal infection, 102-103
 ureteral calculi, 111
 urinary calculi, 152
 urinary tract infection, 125
 vesical calculi, 112
See also Differential diagnosis.
- Diagnostic aspects, of physical therapy, in peripheral nerve injuries, 557, 559-562, 568
- Diagnostic errors, in peripheral nerve injuries, 213
- Diagnostic procedures, in peripheral nerve injuries, 212-217
- Diagrams, in peripheral nerve injuries, 233-238
- Dietary management, in—
 acute spinal cord injuries, 63
 combined bone-nerve injuries, 421
 decubitus ulcers, 9
 paraplegia, 9, 175
 renal calculi, 108
- Dietitians, in paraplegic program, 122
- Differential diagnosis of causalgia, 485-487
- Digital arteries, 328
- Digital nerves:
 cable grafts from, 494
 grafting of, 219, 229, 381, 399, 493
- Digits of hand, loss of extensor function of, 573
- DILLIN, E. L., 567
- Dislocation of hip, in—
 combined bone-nerve injuries, 426
 peroneal nerve injuries, 408
- Disorders of calcium metabolism, in paraplegia, 147
- Disposition, in—
 herniated nucleus pulposus, 200-201
 peripheral nerve injuries, 221-225, 241
- Disruption of suture site—
 after peripheral nerve repair, 228, 243, 244, 416, 519, 533, 539-541
 in combined bone-nerve injuries, 416
 in peroneal nerve repair, 411
 in sciatic nerve repair, 410
- Diverticula of bladder, 81
- Donor sites, in combined peripheral nerve-plastic surgery, 430-431, 432

- Dorsal antibrachial cutaneous nerve, 320, 323, 325
- Dorsal cutaneous branch, of ulnar nerve, 335
- Dorsal interosseous nerve, 320, 326, 406, 424, 573
- Dorsal scapular nerve, 310
- Dorsal sensory branch, of ulnar nerve, 341
- Dorsal spinal cord:
 case fatality rates in wounds of, 115
 cystoscopy in complete transection of, 80-81
- Dorsal sympathectomy, in causalgia, after peripheral nerve injuries, 219
- Dorsiflexion of wrist, after radial nerve injury, 574
- Dorsocutaneous branch of ulnar nerve, 401
- DOUPE, J., 475, 477, 489
- Drainage, in renal infection, 104
- Draping, in peripheral nerve surgery, 367
- Dressings, in decubitus ulcers, 137-138
- Drug addiction, in causalgia, 487
- Drug therapy, in renal calculi, 108
- Drugs, effects of, in cord bladder, 94, 122
- DRUITT, R., 302
- DUELL, A., 493
- Dura:
 compression of, 182
 defects of, in spinal cord injuries, 26
 exploration of, in acute spinal cord injuries, 26
 involvement of, in acute spinal cord injuries, in World War I, 3
 management of, at laminectomy, 54-55
 penetration of, in acute spinal cord injuries, 38
 wounds of, 42-43
- Duration, of peripheral nerve operations, 250, 364-365
- Duty status, after peripheral nerve injuries, 221, 222, 223
- Dysesthesia, in—
 irreparable nerve injuries of foot, 580
 ulnar nerve injuries, 576
- Dysphagia, in vascular-cranial nerve injuries, 448
- Early nerve suture:
 failures of, 228-229
 in combined bone-nerve injuries, 415
 in MTOUSA, 231, 233-237
 principles of, 211-212, 233-237
 rationale of, 210-211
 timing of, 211, 231, 233, 234, 235, 239-242, 363-364, 375, 515, 519, 531-533
- ECHLIN, Maj. F. A., 473n, 488
- Economic considerations, in paraplegia, 17
- Edema—
 after debridement, in peripheral nerve injuries, 235
 in combined bone-peripheral nerve injuries, 564
 in combined peripheral nerve-vascular injuries, 440
 in median nerve injuries, 395
 in peripheral nerve injuries, 515, 528, 536, 538, 558, 562, 563, 564
 of bladder neck, in paraplegia, 72, 91
 of foot, in causalgia, after peripheral nerve injuries, 473n
 of spinal cord, 33, 34, 37, 38, 55, 68
 of urethral orifices, in cord bladder, 80, 100
- Education, continuation of, by paraplegics, 7, 185-186
- Educational considerations, in paraplegia, 17
- Educational level, of paraplegics, 129
- Efferent impulses, from hypothalamus, 475
- Effleurage, 180
- Ejaculation, after acute spinal cord injuries, 101
- Ejaculatory duct, retrograde extension of infection by, 112
- Elastic dressings, in combined peripheral nerve-soft tissue injuries, 564
- Elastic splinting, in peripheral nerve injuries, 566
- Elbow:
 arthodesis of, 571
 exposure of median nerve at, 330-331
 exposure of ulnar nerve at, 339-340
 limitation of extension of, in ulnar nerve injuries, 396-397
 orthopedic surgery, in nerve injuries about, 572-573
- Elective surgery:
 holding period for, in ETOUSA, 203
 in peripheral nerve injuries, 240
- Electrical stimulation—
 after femoral nerve surgery, 407
 at obturator nerve surgery, 407
 at operation, for—
 axillary nerve injuries, 393
 brachial plexus injuries, 392
 femoral nerve injuries, 346
 median nerve injuries, 395, 398
 obturator nerve injuries, 407
 peripheral nerve injuries, 311, 330, 346, 356, 365, 368, 369, 372-374, 375, 377, 392, 521, 526, 541

- Electrical stimulation—Continued
 at operation, for—continued
 radial nerve injuries, 403
 at reexploration, after frozen dried homo-
 grafting, 503, 505, 506-507, 509
 at reoperation, after nerve grafting, 499,
 503
 in assessment of returning motor function,
 256
 in combined bone-nerve injuries, 421
- Electrocoagulation, at peripheral nerve sur-
 gery, 365
- Electrodiagnosis, in peripheral nerve injuries,
 213-217, 213n, 224, 251, 266, 560-562, 567
See also Faradic, Galvanic, etc.
- Electrodiagnostic techniques, in peripheral
 nerve injuries, 213-217, 213n
- Ellik Evacuator, 97, 112
- ELMAN, R., 12
- Emaciation, in paraplegia, 11
- Emotional considerations, in paraplegia, 158-
 162
- Emotional instability—
 as contraindication to work furlough, in
 peripheral nerve injuries, 223
 before causalgia, after peripheral nerve
 injuries, 485
 in causalgia, 479, 487n
- Emotional status, in irreparable nerve in-
 juries, 570
- Emotional stimuli, in causalgia, 475, 479,
 482-485, 486
- Empyema, in paraplegia, 146
- Endoaneurysmorrhaphy, 465
- Endoneurial fibrosis, in peripheral nerve in-
 juries, 517
- End organs, in peripheral nerve injuries, 269,
 271
- Endotracheal anesthesia, for laminectomy,
 50-51
- Endotracheal suction, after laminectomy,
 58
- End-to-end anastomosis—
 after nerve grafts, 376
 in peripheral nerve injuries, 242, 244, 305,
 375-390
 in combined bone-peripheral nerve
 injuries, 246
 in ETOUSA, 249
- Enemas, in paraplegia, 153, 155, 156-157
- England. *See* United Kingdom Base.
- Enlisted men, herniated nucleus pulposus
 in, 198-201
- Enteric fistula, in paraplegia, 146, 147
- Environmental stimuli, in causalgia, 470,
 475, 485, 486
- Ephedrine sulfate, in acute spinal cord
 injuries, 36
- Epididymitis, 112-113, 122, 152
- Epididymo-orchidectomy, 113
- Epilepsy, induced by section of cerebral
 sensory cortex, 183
- Epinephrine. *See* Adrenalin.
- Epineurial fibrosis, in peripheral nerve
 injuries, 235
- Epineurial sutures, in peripheral nerve
 injuries, 243, 364, 384-385
- Epineurium, injection of, with physiologic
 salt solution, 374
- Equinovarus deformity, in peripheral nerve
 injuries, 570, 580, 581, 584
- Equinus deformity, in paraplegia, 173
- Equipment, for—
 chronaxie determinations, 561
 compass test, in peripheral nerve injuries,
 278
 estimation of pain and touch points, in
 peripheral nerve injuries, 276
 footprints and handprints, 265
 galvanic-faradic testing, in peripheral
 nerve injuries, 560-561
 galvanic-tetanus ratio, 561
 nerve block, in quantitative testing of
 muscle strength, 264
 paraplegic program, 8, 9
 peripheral nerve surgery, 365
 peripheral nerve testing, 217
 quantitative assessment, of muscle
 strength, 259-261
 quantitative assessment, of pain sensa-
 tion, 273-274
 quantitative determination, of superficial
 pressure (touch), 275
 resection of damaged nerve ends, 372, 383
 skin temperature testing, 281-282
 spinal surgery, in forward hospitals, 32
 sweat tests, in peripheral nerve injuries,
 279
 testing of pain sensation, in peripheral
 nerve injuries, 267
- Erosion, of peripheral nerves, by aneurysms,
 519, 528-530
- Escherichia coli* infection, in paraplegia, 72,
 102-103
- Esthesiometer, 278
- Ether anesthesia, for laminectomy, 50-51
- Etiology, of—
 acute spinal cord injuries, 25, 32-33

- Etiology, of—Continued
 causalgia after peripheral nerve injuries, 469, 474-478
 decubitus ulcers, 59, 131-134, 147-148
 herniated nucleus pulposus, 194
 pain in paraplegia, 178
 paraplegia, 127-128
 renal calculi, 104-105
 spastic reflexes, in paraplegia, 178-180
- Euphoria, in paraplegia, 17, 160, 186
- Europe. *See* Continent.
- European Theater of Operations:
 acute spinal cord injuries in, 25-30
 electrodiagnosis in, 560-561
 herniated nucleus pulposus in, 203
 holding policy in, 244, 245
 management of cord bladder in, 120-121
 management of peripheral nerve injuries in, 211, 239-250
 physical therapy for peripheral nerve injuries in, 563
- Evacuation—
 after laminectomy, 58
 after peripheral nerve repair, in ETOUSA, 244
 in acute spinal cord injuries, 3, 26-27, 47-49, 63-64
 in paraplegia, 30, 131-135
 in MTOUSA, 23
 in World War I, 31
 timing of, 30
 to Zone of Interior, 120-121
 in peripheral nerve injuries, 235, 240-241
 in World War I, 208
 of casualties with combined bone-peripheral nerve injuries, 246
 of casualties with herniated nucleus pulposus, 202, 203
 priorities of, 222, 240
See also Air evacuation, Transportation.
- Evacuation hospitals:
 acute spinal cord injuries in, 32, 35, 36
 in ETOUSA, 26, 29
 management of cord bladder in, 61
 management of acute spinal cord injuries in, 120
 in World War I, 4
 postlaminectomy care in, 58
 primary nerve suture in, 233
- Evaluation, of—
 patients for work furloughs, 223
 peripheral nerve injuries, at operation, 372-376
- Evaluation, of—Continued
 progress, in peripheral nerve injuries, 224-225
- Excision and quadruple ligation, in arteriovenous fistulas, 465
- Exercises—
 for paraplegics, 163-164
 in peripheral nerve injuries, 563
- Expectant management, of peripheral nerve injuries, 211, 231
- Experimental studies, in—
 cord bladder, 67, 68, 73
 frozen dried homografts, 218, 495
 peripheral nerve injuries, 239, 381, 566
 in World War I, 207, 219
 peripheral nerve regeneration, 302, 515
 peripheral nerve repair, 211, 243
 physical therapy in peripheral nerve injuries, 246, 557, 564
- Exploration—
 in acute spinal cord injuries, 25-57
 in peripheral nerve injuries, 211, 234, 243, 254
 after use of tantalum foil, 287-288
 through dura, at laminectomy, 55
- Exploratory laminectomy, in—
 acute spinal cord injuries, 47
 paraplegia, 181-182
- Exposure, at operation—
 for peripheral nerve injuries, 207, 369-370
 in axillary nerve injuries, 317-318
 in brachial plexus injuries, 311-313
 in musculocutaneous nerve injuries, 316
 in radial nerve injuries, 322-326
 in ulnar nerve injuries, 338-342
 of common peroneal nerve, 360-362
 of femoral nerve, 346-349
 of median nerve—
 at elbow, 330-331
 at wrist, 333
 in arm, 330-333, 394, 395, 396
 in forearm, 331-333
 in hand, 333
 of posterior tibial nerve, 359
 of radial nerve—
 in arm, 323-325
 in axilla, 402
 in forearm, 325-326
 of sciatic nerve, 354-357
 of terminal divisions, of sciatic nerve, 357-362
 of tibial nerve, 357-359

- Exposure, at operation—Continued
of ulnar nerve—
in arm, 339-340
in axilla, 338
in forearm, 340-342
- Exposure technique, of frozen dried homografting, 506-508
- Extension contracture, in combined bone-nerve injuries in forearm, 423
- Extension deformity, of metacarpophalangeal joints, 571
adjacent joints, after peripheral nerve surgery, 244, 247, 380
elbow, limitation of, in ulnar nerve injuries, 396-397
spine and head, in acute injuries, 23, 35
- Extensor carpi—
radialis, 256, 325, 404, 406
radialis brevis, 320, 326, 574
radialis longus, 320, 325, 574
ulnaris, 320, 326, 406
- Extensor digiti quinti proprius, 320, 326
- Extensor digitorum—
brevis, 361
communis, 320, 326, 406
longus, 353, 361, 362, 411
- Extensor function, of digits, loss of, 573
- Extensor hallucis longus, 225, 353, 362
- Extensor indicis proprius, 320, 326, 406, 574
- Extensor muscle paralysis, in peripheral nerve injuries, 566
- Extensor pollicis—
brevis, 406, 574
longus, 320, 406
- Extensors, of thumb, 320, 326
- External condyle, of humerus, 325
- External fixation, in combined bone-nerve injuries, 564
- External genitalia, complications in, in cord bladder, 112-114
- External iliac artery, 344, 346, 347
- External jugular vein, 312
- External oblique aponeurosis, 346, 349
- External popliteal nerve injuries, associated with tibial-fibular injuries, 584
- Extradural hemorrhage, in acute spinal cord injuries, 34, 54
- Extramedullary hematoma, 55
- Extremities, wounds of, 21, 30
- Facial nerve grafts, 219, 229, 381, 493, 494, 498, 510
- Facies, in causalgia, after peripheral nerve injuries, 480
- FAHLUND, Capt. G. T. R., 513
- Failures—
of early peripheral nerve suture, 228-229
due to inadequate resection of nerve ends, 236
of peripheral nerve grafts, 381-382, 494-495
of primary nerve suture, 228, 232-233
- False aneurysm—
associated with peripheral nerve injuries 442, 465
in combined peripheral nerve-vascular injuries, 440
- Family care, of paraplegics, 15, 16-17, 160
- Faradic stimulation—
at peripheral nerve surgery, 365, 368, 369
in peripheral nerve injuries, 213
- Fascial graft, for dural closure, at laminectomy, 55
- Fascicles:
fibrosis of, 558
ischemia of, 374
loss of continuity of, 374-375
management of—
at peripheral nerve surgery, 376-377, 379, 381, 395
in peripheral nerve grafts, 382
of sciatic nerve, as frozen dried homografts, 497
- Fat content, of diet, in paraplegia, 150
- Fat-soluble vitamins, in paraplegia, 150
- Fecal impaction—
in acute spinal cord injuries, 62, 63
in paraplegia, 153
- Feet, quantitative assessment of muscle strength in, 256-263
- Female, acute spinal cord injuries in, 118-119
- Femoral aneurysms, 465
- Femoral artery, 344, 346, 349, 406, 455
- Femoral nerve:
anatomy of, 343-346, 347, 349
formation of, 343-346
injuries of, 343-350
closure of wound in, 349
electrical stimulation at operation for, 346
exposure of, 349
positioning at operation for, 346, 350
study of specimens from, 514
techniques of gaining length in, 350
physiology of, 344-345
surface anatomy of, 346
surgical approach to, 346-349
terminal branches of, 344-346, 349, 350

- Femoral vein, 349
- Femur:
- fractures of, associated, with peripheral nerve injuries, 49, 416, 420-421 internal fixation of, 428
- Ferric chloride sweat tests, in peripheral nerve injuries, 279
- Fever, in—
- cystitis, 111
 - epididymitis, 112
 - renal infection, 102, 103
 - ureteral calculi, 111
 - urinary tract infection, 146
- Fibrin film, 385-386
- Fibrin film technique, of peripheral nerve repair, 236, 375, 390, 535
- Fibrin foam, 55, 365, 382
- Fibroplasia, after peripheral nerve suture, 236
- Fibrosis:
- after debridement, in peripheral nerve injuries, 235
 - after frozen dried homografting, 505, 508, 509, 510, 546-547
 - after peripheral nerve surgery, 386
 - development of, in relation to suture material, 389
 - effect of, on nerve regeneration, 550
 - in brachial plexus injuries, 391
 - in peripheral nerve grafts, 381-382
 - in peripheral nerve injuries, 234, 244, 246, 249, 382, 513, 515, 519, 528, 533-534, 539, 541, 543, 555, 557-558, 584
 - of bladder wall, in paraplegia, 95
 - production of, by prolonged immobilization, 570
 - relation of ischemia to, 376
 - See also* special types of fibrosis, Histopathologic process in peripheral nerve injuries, etc.
- Fibula:
- fractures of, associated with peripheral nerve injuries, 584
 - resection of head of, 362, 410
 - resection of neck of, 411
- Field hospitals, management:
- of acute spinal cord injuries in, 32, 35, 36, 120
 - of cord bladder in, 61
 - postlaminectomy care in, 58
- Field Medical Record, 533
- Fifth Service Command, 151n
- Fifth U.S. Army, 19
- Fifteenth U.S. Army, 120
- Fingers:
- ankylosis of, 584
 - clawing of, 265, 571, 576-577
 - extension function of, 574
 - function of, after sublimis tendon surgery, in median nerve injuries, 577
 - orthopedic procedures on, 572-573, 577
 - pain in, in causalgia, 478-480
- First aid, in acute spinal cord injuries, 35-36
- First intercostal nerve, 310
- First thoracic ganglion, 310
- First U.S. Army, 65
- Fistula formation—
- after ureterotomy, 111
 - at penoscrotal junction, 90-91, 97
 - See also* specific types.
- Fixed hospitals, acute spinal cord wounds in, 19
- Flaccid paralysis, in acute spinal cord injuries, 37
- Flap closure, in combined peripheral nerve-soft tissue injuries, 564
- Flexion contractures—
- in median nerve injuries, 330
 - in radial nerve injuries, 322, 325
 - of knee, 579
- Flexion creases:
- avoidance of—
 - at peripheral nerve surgery, 301, 304, 322, 338, 341, 369
 - in median nerve surgery, 397
 - in popliteal space, 359, 411, 412
 - in radial nerve surgery, 325
 - in sciatic nerve surgery, 357-358 - in hand, 401
 - in thigh, 349
 - of elbow, 406
- Flexion of contiguous joints, in peripheral nerve injuries, 236, 243, 249, 377-379
- Flexion-relaxation—
- combined with bone shortening, 380
 - in ulnar nerve injuries, at elbow, 400
- Flexor carpi—
- radialis, 328, 331
 - radialis tendon, 328
 - ulnaris, 333, 335, 337, 340, 343, 396, 400
 - transplantation of, 574
 - ulnaris tendon 337, 340, 341
- Flexor digiti quinti brevis, 337
- Flexor digitorum—
- brevis, 352
 - longus, 352, 359, 413
 - muscles, 340

- Flexor digitorum—Continued
 profundus, 328, 331, 333, 335, 340, 343, 400
 sublimis, 328, 331, 397
 sublimis tendon, 328, 331
- Flexor hallucis—
 brevis, 352
 longus, 352, 359, 413
- Flexor paralysis, in peripheral nerve injuries, 566
- Flexor pollicis—
 brevis, 328, 333, 337
 longus, 328, 331, 333
- Flexor profundus digitorum, 343
- Flexor profundus, innervation of, 263
- Flexor, spasm, in paraplegia, 181
- Flexor sublimis, 343
- Flexor sublimis tendons, 341
- Flexor tendons, of fingers, 337
 injuries of, associated with ulnar nerve injuries, 576
 transplantation of, 406
- Fluid balance, after laminectomy, 57
 in cord bladder, 124
 in renal calculi, 108
 in renal infection, 103
- Fluid infection, of distal peripheral nerve segment, 384
- Fluorescein studies, in decubitus ulcers, 136
- Foley catheter, 91
- Footdrop, in paraplegia, 162
- Forearm, exposure of:
 median nerve in, 331-333
 radial nerve injuries in, 325-326
- Followup—
 in causalgia, after peripheral nerve injury, 490
 in herniated nucleus pulposus; 193-194
 in peripheral nerve injuries, 213, 221-230, 243-244
See also Peripheral Nerve Registry.
 of paraplegics
 in VA, 12-13n
 in World War I, 3
- Foot:
 causalgia in, 478, 479, 481, 487
 cavus deformity of, in peripheral nerve injuries, 579
 stabilization of, irreparable nerve injuries, 580
- Footdrop, in—
 paraplegia, 22, 162
 peripheral nerve injuries, 237
- Footprints and handprints, in neurologic testing, 265-266
- Forearm:
 causalgia in, 478
 combined bone-nerve injuries in, 423-425
 exposure of—
 median nerve injuries in, 331-333
 radial nerve injuries in, 325-326
 ulnar nerve injuries in, 340
- Forehead, decubitus ulcers on, 131
- Foreign bodies, in acute spinal cord injuries, 9, 19-20, 21, 26, 31, 32-33, 35, 38, 44-47, 146
 causation of pain by, 178
 in cauda equina, 181
 management of, at laminectomy, 52-54
 roentgenologic demonstration of, 39, 40
See also Bone fragments.
- Foreign body reactions, after—
 homogenous nerve grafting, 495
 peripheral nerve repair, 390, 533-535
- Formation, of—
 axillary nerve, 317
 brachial plexus, 305-308, 310-311
 common peroneal nerve, 351, 357
 musculocutaneous nerve, 313-314
 radial nerve, 318-320, 328
 sciatic nerve, 350
 tibial nerve, 351, 357
 ulnar nerve, 335-337
- Formication, 272
- Foroblique lens system, 80
- Forward hospitals:
 deaths from acute spinal cord injuries in, 64-65
 management of acute spinal cord injuries in, 19, 64
 nursing care of acute spinal cord injuries in, 63
 postlaminectomy care in, 57
- Fossa ovalis, 349
- Fowler's position, for defecation, in paraplegia, 155
- Fracture-dislocations, of spine, 20, 25, 35
- Fractures—
 associated with peripheral nerve injuries, 232
 associated with spinal cord injuries, 50, 146, 178, 181
 of femur, 49
 of long bones, 244-246
 of vertebrae, 25, 33, 47
See also special bones.
- France, 89, 120

- FRENCH, Maj. L. A., 231
 French management, of cord bladder, in World War I, 119
 FROMME, A., 448
 Frozen dried homografting, technique of, 497-498
 Frozen dried homografts, 218-219, 220-221, 493-512
 histopathologic process in, 514, 546
 results of, 499-512
 statistics of, 495, 502-512
 Frozen hand, 454, 463-464
 Frozen joints, in peripheral nerve injuries, 236-237, 245, 246, 247
 Fulguration, of urethral fistula, 113
 FULTON, J. F., 68
 Furloughs, in—
 paraplegia, 185
 peripheral nerve injuries, 223, 224
 Furmethide iodide, in peripheral nerve testing, 279, 280n
 Fusiform neuroma, 375, 400
 Fusion operations—
 in irreparable nerve injuries, of upper extremity, 571
 on ankle, 580

 GALEN, 301, 302
 Galvanic-faradic testing, in peripheral nerve injuries, 560-561
 Galvanic stimulation, in peripheral nerve injuries, 213, 246-247, 565, 567
 Galvanic-tetanus ratio, in peripheral nerve injuries, 213, 561-562
 Gangrene, after peripheral nerve-vascular injuries, 238
 Gas-oxygen-ether anesthesia, for laminectomy, 51
 Gastrocnemius, 351, 352, 353, 358, 359, 362, 412, 413
 Gastrointestinal complications, in acute spinal cord injuries, 35
 Gastrointestinal tract, care of, in acute spinal cord injuries, 63
 Gastrointestinal wounds, 147
 Gelfoam, 365, 385-386
 Gemelli, 351
 General anesthesia, in—
 combined bone-peripheral nerve surgery, 422
 peripheral nerve surgery, 369
 General Hospitals:
 ETOUSA, 26, 29

 General Hospitals—Continued
 overseas, management of acute spinal cord injuries in, 31, 32-65
 serving as transit hospitals, 240
 Gentian violet, in decubitus ulcers, 137
 Genitourinary complications, in acute spinal cord injuries, 101-114
 Genitourinary consultations, in paraplegia, 129
 German management, of cord bladder, in World War I, 119
 Girdle pain, 178
 Glioma:
 management of, at peripheral nerve surgery, 384
 resection of, 377, 380-381
 traction on, 380
 Glioma formation, in—
 common peroneal nerve injuries, 413
 peripheral nerve injuries, 382, 538
 radial nerve injuries, 404
 Glossolaryngoscapulopharyngeal hemiplegia, 442
 Glossopharyngeal nerves, 441
 Gluteus maximus, 142, 143, 351
 exposure of sciatic nerve beneath, 354-356
 Gluteus maximus tendon, 408
 GOODMAN, E. N., 475, 485
 GORDON, W. G., 91, 94
 Gracilis tendon, 345
 Grafts. *See* specific types.
 GRANIT, 475, 476
 Granville's lotion, 473n
 Graphic records, in—
 decubitus ulcers, 135
 peripheral nerve injuries, 253, 256, 273, 275-276, 277, 282
 Gray Ladies, 187
 Great sacrosciatic foramen, 350
 Great saphenous vein, 349
 Greater trochanter, 351, 354
 Greenwood bipolar electrocoagulation forceps, 365
 GROSS, S. W., 383
 Guadalcanal, 7
 Gunshot wounds—
 as cause of paraplegia, 128
 of spine, 25
 GUTMANN, E., 364

 HAHN, J., 93
 HALL, M., 68
 Hallucinatory answers, in neugologic testing, 376

- Hamstrings, 351, 354, 356, 408, 409, 410, 412
transplantation of, in quadriceps paralysis, 579
- Hand:
ankylosis of, after prolonged immobilization, 584
causalgia in, 478, 479, 480, 481, 487
exposure of median nerve injuries in, 333
frozen joints in, 246, 247
quantitative assessment of muscle strength in, 256-263
sweat test of, 279
- Hand center, management of median nerve injuries in, 399
- Handprints and footprints, in neurologic testing, 265-266
- HANSON, A. M., 31
- HARGRAVE, Prof., 80
- HARRISON, Lt. Col. J. H., 121
- HARTWELL, J. B., 113
- Harvey Cushing Society, 470
- HATT, Maj. R. N., 582
- HAWLEY, Maj. Gen. P. R., 14, 17
- HAYNES, W. G., 37, 44, 46, 65
- HAYS, Maj. Gen. S. B., 29
- HEAD, H., 67, 70, 71, 111, 273, 278
- Head injuries, priority of evacuation in, 240
- Head's spring algometer, 273-274
- Healing—
after delayed primary wound closure, 235
in decubitus ulcers, 10, 138-139
in peripheral nerve injuries, 249
- Heat therapy, in peripheral nerve injuries, 247, 564
- Heel cord, lengthening of, in paraplegia, 173
- Heels, decubitus ulcers on, 131
- Hematocrit determinations, in paraplegia, 129, 149
- Hematogenous origin, of—
epididymitis, 112
renal infection, 102
- Hematoma formation, in acute spinal cord injuries, 34
- Hematomyelia, 68
- Hematuria, in renal calculi, 105-106
- Hemilaminectomy, in—
acute spinal cord injuries, 56-57
herniated nucleus pulposus, 193
- Hemorrhage—
at operation, for brachial plexus injuries, 313
for ulnar nerve injuries, 340
from gluteal vessels, in sciatic nerve surgery, 409
- Hemorrhage—Continued
in brachial plexus injuries, 391, 392
in combined peripheral nerve-vascular injuries, 440
in peripheral nerve injuries, 536, 543
into (about) spinal cord, 34
- Hemostasis:
at laminectomy, 52, 55
at peripheral nerve surgery, 243, 365, 372, 385-386
effect of local anesthesia on, 368
- Hemothorax, 48-49
- Hepatitis, 116
- HERMANN, L. G., 477
- Herniated nucleus pulposus, 56, 193-203
classification of patients with, 194
clinical picture of, 193, 196
diagnosis of, 193
disposition in, 200, 201
etiology of, 194
historical note on, 193-194
in MTOUSA, 202, 203
incidence of, 194, 194n, 198
indications for surgery in, 200-201
line-of-duty status in, 200-201
management of, in Zone of Interior, 194-202
results of surgery in, 200-203
statistics of, 198-201, 203
- HEROY, W. W., 475, 485
- Heterogenous nerve grafts, 381
- HEYROVSKY, J., 442
- High velocity missiles, as cause of peripheral nerve injuries, 235, 363-364
- HIGHET, W. B., 264
- HINMAN, F., 89, 93, 95
- Hip, dislocations of, in combined bone-nerve injuries, 408, 426
- Hip spica, for transportation splinting, in peripheral nerve injuries, 420-421
- HIPPS, H. E., 558
- Histopathologic-neurosurgical cooperative study, in peripheral nerve injuries, 219-221, 513-555
- Histopathologic process, in peripheral nerve injuries, 364, 513-555
See also Pathologic process, Fibrosis, Neurotization, etc.
- Histopathologic studies—
in frozen dried homografts, 499, 504-505, 507-509
of nerve grafts, 543-555
- Historical note:
acute spinal cord injuries, 3-4

- Historical note—Continued
 causalgia, 469
 herniated nucleus pulposus, 193-194
 peripheral nerve injuries, 207-210, 301-304
- History taking, in—
 acute spinal cord injuries, 36
 combined peripheral nerve-vascular injuries, 440-441
 paraplegia, 129
 peripheral nerve injuries, 253-254
- Holding policies, in ETOUSA, 203, 244, 246
- Hollow viscera, perforating wounds of, 147
- HOLMES, G., 68, 69, 70
- HOLMES, W., 494
- HOMANS, J., 477, 478
- Homogenous nerve grafts, 218-219, 381, 493, 494-495, 546
 procurement of, from amputated limbs, 494
- Hormone therapy, in renal calculi, 108
- Horse serum, in decubitus ulcers, 137
- Hospital conferences, on peripheral nerve injuries, 254
- Hospital Construction Branch, OTSG, 17
- Hospital Division, OTSG, 8
- Hospital organization, in paraplegic program, 6, 22-23
- Hospitalization policies, in peripheral nerve injuries, 221-225, 244
- Hospitals. *See* specific types.
- Hospitals, evacuation:
 15th—232
 45th—65
 128th—65
- Hospitals, general:
 named:
 Army and Navy, 18
 Ashford, 146, 212, 448, 456, 543
 Birmingham, 14
 Brooke, 18
 Bushnell, 8, 180
 Cushing, 14, 18, 137, 140, 142, 174, 175, 187, 218, 223, 244, 251-300, 495-512
 DeWitt, 18, 135, 138, 140, 182, 212
 Dibble, 140
 Fitzsimons, 18
 Halloran, 6, 127, 128, 143, 145, 149, 194n, 217, 221, 404, 415-428, 429-438, 513-555, 564
 Hammond, 6, 7, 127, 133, 161, 176, 184, 187, 188, 189n
 Kennedy, 14, 15, 18, 194, 487, 488
 Lawson, 575
 Letterman, 18
- Hospitals, general—Continued
 named—continued
 McCaw, 9-11, 18, 138, 180, 184, 185, 188, 488
 McCloskey, 301, 349, 473n
 McCornack, 18
 McGuire, 14, 18
 Mayo, 212
 Newton D. Baker, 6, 8, 9, 127, 131, 140, 182, 189, 190, 217
 Nichols, 11
 Oliver, 18
 O'Reilly, 200
 Percy Jones, 18, 127, 128, 146, 191, 213, 217, 470, 474, 475, 476, 478, 480, 485, 487, 489, 490
 Pratt, 18
 Schick, 489
 Thomas M. England, 6, 127, 582
 Valley Forge, 582
 Vaughan, 14, 18
 Walter Reed, 18, 162-163, 195, 198, 200, 217, 218, 221, 225, 477, 494, 495, 497, 514, 535, 547
- numbered:
 21st—238
 26th—231
 33d—22, 234, 236, 238
 55th—482, 485, 487
- Hospitals, various:
 Boston City Hospital, 495
 Christian Street Hospital, 302
 General Hospital No. 11—210
 New York Institute for the Crippled and Disabled, 162
 Peter Bent Brigham Hospital, 495
 St. Alban's Naval Hospital, 498
 Turner Lane Hospital, 302
- HOWELL, W. H., 303
- HUBER, G. C., 207, 219, 303
- Human hair sutures, in peripheral nerve surgery, 388
- Humerus:
 abduction of, by trapezius transplantation, 572
 capitellum of, 325
 exposure of axillary nerve at surgical neck of, 318
 external condyle of, 325
 fractures of—
 combined with peripheral nerve injuries, 238, 416-420
 combined with radial injuries, 256, 402-404, 573

- Humerus—Continued
 fractures of—continued
 lateral condyle (epicondyle) of, 321
 medial epicondyle of, 335, 338, 339, 340, 342, 343, 395
 shortening of, in combined bone-nerve injuries, 236, 380, 416–420, 422–423
 shortening of, in radial nerve injuries, 404
 supracondylar fractures of, associated with radial nerve injuries, 428
 surgical neck of, 317
 transplantation of origins of wrist and finger flexors on, 572–573
- Hunter's canal, 345
- Hydronephrosis, 100, 109
- Hypalgesia, in peripheral nerve injuries, 269, 273
- Hypercalciuria, 104, 108
- Hyperemia, as cause of causalgia, after peripheral nerve injuries, 474–475
- Hyperesthesia, in—
 acute spinal cord injuries, 37, 50
 causalgia, after peripheral nerve injuries, 476, 478, 479, 482
- Hyperextension, in—
 compression fractures of vertebrae, 35
 fractures of cervical spine, 59
- Hyperextension deformity, of wrist, after muscle transplantation, 574
- Hypertonic bladder, 85, 86
- Hypesthesia:
 in herniated nucleus pulposus, 196
 in peripheral nerve injuries, 269
 sweat test in, 279
- Hypnotics, role of, in development of decubitus ulcers, 148
- Hypoglossal nerve, 441, 494
- Hypoproteinemia. *See* Protein deficit.
- Hypostatic pneumonia, after laminectomy, 58
- Hypotension, in acute spinal cord injuries, 36
- Hypothalamus, 475
- Hypothenar muscles, 401
- Hysteria, 485, 486
 at debridement in peripheral nerve injuries, 253, 364, 376, 384, 519
 at ulnar nerve surgery, 339, 342
 in frozen dried homografts, 498
- Ileus, in acute spinal cord injuries, 63
- Iliac spines, decubitus ulcers over, 131
- Iliacus, 344, 346, 350
- Iliohypogastric nerve, 346
- Iliinguinal nerve, 346
- Iliopsoas, 349
- Iliotibial tract of fascia lata, 408
- Immobility, effect of, in development of decubitus ulcers, 148
- Immobilization:
 after peripheral nerve surgery, 366–367, 384
 in acute spinal cord injuries, 23
 of vertebral fractures, during evacuation, 132
 risk of, in peripheral nerve injuries, in upper extremity, 584
- Impotence, in paraplegia, 114, 114n
- Improvised equipment, in paraplegic program, 8
- Improvised transportation splinting, in peripheral nerve injuries, 242
- Incidence of—
 acute spinal cord injuries, 19–20
 brachial plexus injuries, 391
 causalgia after peripheral nerve injuries, 469, 470–473, 473n, 475
 combined bone-peripheral nerve injuries, 564
 combined humerus-radial nerve injuries, 325, 402
 combined peripheral nerve-soft tissue injuries, 564
 combined peripheral nerve-vascular injuries, 439n, 439–440
 disruption of suture line, after peripheral nerve repair, 244
 femoral nerve injuries, 406
 herniated nucleus pulposus, 194, 194n, 198
 irreparable gaps in peripheral nerve injuries, 249
 multiple peripheral nerve injuries, 238
 peripheral nerve erosion by aneurysms, 528
 peripheral nerve injuries, 128, 211, 212, 225, 493, 514
 in ETOUSA, 247–250
 in MTOUSA, 237
 in World War I, 237
 peroneal nerve injuries, 411
 phantom limb, 478
 renal calculi in paraplegia, 104–105
 ulnar nerve injuries, 400, 514
 vascular-cranial nerve injuries, 442
 vascular peripheral nerve injuries of—
 lower extremity, 455
 upper extremity, 448
 vesical calculi, 112

Incisions—

- for hemilaminectomy, 56-57
 - for laminectomy, 52
 - for sympathectomy, 488-489
 - in axillary nerve injuries, 317-318, 393
 - in brachial plexus injuries, 311-313, 391, 392, 403
 - in femoral nerve injuries, 346-347, 349, 407
 - in median nerve injuries, 330-331, 333, 394, 395, 396, 397-398, 399
 - in musculocutaneous nerve injuries, 316, 394
 - in obturator nerve injuries, 407
 - in peripheral nerve injuries, 304, 305, 369-372
 - in peroneal nerve injuries, 411
 - in posterior tibial nerve injuries, 359, 412-413, 414
 - in radial nerve injuries, 322-326, 405, 406
 - in sciatic nerve injuries, 354-356, 408, 410
 - in tibial nerve injuries, 412-413
 - in ulnar nerve injuries, 338-342, 400, 401
 - See also* Anatomic approaches, Exposure.
- Incomplete peripheral nerve injuries, 252-253, 547
- association of bone injuries with, 519
 - causalgia after, 473, 475, 476
 - frozen dried homografts in, 495, 499, 512
 - histopathologic process in, 514, 519
 - stretch fibrosis in, 541-543
- Incomplete neuroma, 519
- Incomplete transection of cauda equina, 77
- cord bladder in, 118, 123
 - sex function after, 101, 114
- Incomplete transection of spinal cord, 16, 19-20, 21, 32, 37, 39, 45-46
- case fatality rates in, 115
 - cord bladder in, 71, 86, 114, 116, 117, 124
 - cystography in, 81
 - cystometry in, 77
 - cystoscopy in, 79
 - in World War I, 3, 31
 - pain in, 43-44, 178
 - vesical calculi in, 112
- Incomplete ulnar nerve injury, 576
- Indications for—
- amputation in paraplegia, 183
 - emergency surgery in combined aneurysm-peripheral nerve injuries, 464
 - intradural exploration at laminectomy, 55
 - laminectomy, 41-47
 - myelography, 197
 - resection of neuromas, 375
 - selection of anesthesia for laminectomy, 49

Indications for—Continued

- surgery, for—
 - causalgia in posterior tibial nerve injuries, 414
 - decubitus ulcers, 139
 - herniated nucleus pulposus, 196-197, 200-201, 202-203
 - peripheral nerve injuries, 252
 - spinal cord wounds, 20-21
 - transfer of paraplegics to VA, 5, 13-14
 - use of frozen dried homografts, 496-497
- Incontinence of feces, in acute spinal cord injuries, 63
- Inductorium, 365, 372-374
- Industrial compensation, in causalgia, after peripheral nerve injuries, 487n
- Indwelling catheter—
- during evacuation, in acute spinal cord injuries, 29, 64
 - in acute spinal cord injuries, 22, 30, 36, 61
 - in management of cord bladder, 61-62, 120
- Infantry, paraplegia in, 128
- Infection:
- after early nerve suture, 228
 - as cause of death in paraplegia, 11-12
 - at reparative surgery, for peripheral nerve injuries, 234
 - in acute spinal cord injuries, 21
 - in combined bone-nerve injuries, 420-421, 426-427, 439
 - in cord bladder, 115
 - in etiology of—
 - causalgia after peripheral nerve injuries, 474
 - decubitus ulcers, 131
 - renal calculi, 104
 - in frozen dried homografting, 503
 - in peripheral nerve injuries, 211, 241
 - in World War I, 210
 - in primary nerve suture, 232
 - of bladder wall, in acute spinal injuries, 71
 - of cord bladder, 72-73
 - in World War I, 4
 - of prostate, in peroneal urethroscopy, 97
 - of pubis, in suprapubic cystostomy, 97
 - of urethra, in catheter drainage of cord bladder, 99
 - prevention of, in acute spinal cord injuries, 35, 42-43
 - relation of, to hypoproteinemia in paraplegia, 12
- Inferior cervical sympathetic ganglion, 310
- Inferior epigastric vessels, 347
- Inferior gluteal vessels, 354

- Inferior petrosal sinus, 441
 Inferior ulnar collateral artery, 331
 Inframedullary hemorrhage, in acute spinal cord injuries, 34
 Infrared treatment, of decubitus ulcers, 22
 Infraspinal, 310
 Initial wound surgery. *See* Debridement.
 Innominate vein, 312
 Interaction of nerve fiber impulses as cause of causalgia, 476
 Intercostobrachial nerve, 322
 Interfunicular crossings, in median nerve surgery, 397
 Interlaminar resection, of intervertebral disk, 193
 Intermittent catheterization, in—
 cord bladder, 90, 99
 World War I, 114, 119
 Internal fixation—
 in combined bone-peripheral nerve injuries, 235, 246, 404, 422, 425
 infection after, 427
 of femur, 428
 Internal iliac artery, 409
 Internal jugular vein, 441
 Internal malleolus, 413
 Internal oblique muscle, 346, 349
 Internal saphenous vein, 359
 Internists, in paraplegic program, 190
 Interosseus membrane, 353
 Interosseus muscles, 337, 401
 use of, in irreparable median nerve injuries, 577
 Interphalangeal joints:
 arthrodesis of, 579
 fusion of, 571
 Intertransverse muscles, 305
 Intervertebral disk, interlaminar resection of, 193
 Intestinal origin of renal infection, in paraplegia, 102
 Intradural exploration, at hemilaminectomy (laminectomy), 55, 57
 Intramedullary hemorrhage, in acute spinal cord injuries, 55
 Intramedullary pins, 564
 Intra-neural fibrosis, 374
 Intratracheal anesthesia, in peripheral nerve repair, 249
 Intrathecal penicillin therapy, 39, 58, 65
 Intravenous pyelography, 81, 106, 124
 Intravenous urography, 100, 102, 103, 104, 111, 121, 125
 Intrinsic musculature of foot, loss of, in posterior tibial nerve injuries, 412
 Iodine-starch sweat test, in peripheral nerve injuries, 280
 Iodoform, in decubitus ulcers, 137
 Iophendylate. *See* Pantopaque.
 Iris forceps, in peripheral nerve surgery, 384
 Irreparable peripheral nerve injuries, 225, 569-585
 incidence of, 249
 Irrigations, in—
 cord bladder, 91-94, 123-124
 renal calculi, 110
 suprapubic cystostomy, 95
 Ischemia—
 after damage to brachial artery, 395
 as cause of causalgia, after peripheral nerve injuries, 474-475, 476
 effect of, in peripheral nerve injuries, 219, 543
 in autogenous nerve grafts, 382
 in combined vascular-peripheral nerve injuries, 212, 465
 in etiology of decubitus ulcers, 23, 59, 131, 132, 133
 in peripheral nerve injuries, combined with vascular occlusion, 458, 463
 of fascicles, 374
 of peripheral nerves, from careless mobilization, 376
 of peripheral nerves, from scarring, 37
 Ischemic contractures, in vasomotor-peripheral nerve injuries, 280
 Ischemic paralysis, in—
 median nerve injuries, 394
 peripheral nerve injuries, 364
 Ischial tuberosities, decubitus ulcers over, 131
 Ischium, tuberosity of, 351
 Italy, 19
 JACKSON, J. H., 441
 JACOBS, Capt. M. A., 148
 Joint changes, in—
 causalgia, 481
 peripheral nerve injuries, 558, 562-563
 Joint-peripheral nerve injuries, 253, 304
 Joint sense, testing of, in peripheral nerve injuries, 266-272
 Joints, effect of galvanic stimulation on, in peripheral nerve injuries, 565
 Joints:
 extension of, after peripheral nerve repair, 244, 247, 380

- Joints—Continued
 flexion of, after peripheral nerve repair, 236, 243, 249
 movement of, after combined bone-peripheral nerve surgery, 245
 pain in, in causalgia, 478, 486
- JONES, R., 263
- Jugular compression test, 196
- Jugular foramen, 441, 448
- Jugular vein, 308
- Kahn test, 129
- KEEN, W. W., 301, 302, 469, 473n, 478, 479
- Keloid formation, after—
 femoral nerve injuries, 349
 medial nerve injuries, 330
 radial nerve injuries, 322, 325
 ulnar nerve injuries, 338
- KENNEDY, Col. R. H., 146, 161, 190, 191
- KESSLER, H., 12
- KIDD, F., 67, 68, 90
- Kidney, cortical abscess of, 101, 109
- Kidney function, after acute spinal cord injury, 100–101
- KIRKLIN, Capt., B. I., 474
- KLEMPERER, Capt. W. W., 19, 20
- Knee joint, fractures of, associated with peripheral nerve injuries, 420–421
- Knee, orthopedic surgery on, for paralysis below, 579, 580
- KWAN, S. T., 469
- Laboratory examinations, in—
 cord bladder, 124
 paraplegia, 129
 peripheral nerve injuries, 254
- Laboratory personnel, shortages of, for peripheral nerve studies, 220
- Laboratory studies, in protein deficits, in paraplegia, 148–149
- Lacertus fibrosus, 328, 330
- Lambrinudi operations, for equinus (equinovarus) deformities, 580
- Laminectomy, in acute spinal cord injuries, 9, 20–21, 33, 38, 39, 41, 57, 70
 adjunct therapy after, 57
 administrative considerations in, 47–49
 anesthesia for, 49–51
 antimicrobial therapy after, 58
 bladder drainage after, 58
 case fatality rates in, 65, 181
 changes of position after, 58–59
 contraindications to, 21
 evacuation after, 63
- Laminectomy, in acute spinal cord injuries—Continued
 for exploration, 47
 in cadaver to secure nerve grafts, 497
 indications for, 41–47
 in forward hospital, 32
 in World War I, 31, 41
 postoperative care in, 57–61
 preoperative medication in, 49
 special problems after, 58–61
 statistics of, 182
 technique of, 52–57
 timing of, 44, 47–49, 182
- LAMPSON, R. S., 74
- Larynx, paralysis of, 441
- Lateral antebrachial cutaneous nerve, 314, 325, 330
- Lateral anterior thoracic nerve, 310
- Lateral bicipital sulcus, 321, 325
- Lateral brachial cutaneous nerve, 322–323
- Lateral circumflex artery, 349
- Lateral condyle of humerus, 316, 321
- Lateral epicondyle of humerus, 314, 321
- Lateral femoral cutaneous nerve, cable graft from, 494
- Lateral neuroma, 377
- Lateral plantar nerves, 352
- Lateral sural cutaneous nerve, 353
- Lateral traction, 421
- LATHROP, F. D., 493
- Latissimus dorsi, 310, 317, 318, 322
- LAUGIER, 303
- LAVER, C. H., 93
- LAWRIE, R. S., 93
- LEARMONTH, J. R., 385
- Leg:
 anomalous innervation of, 490
 bone-peripheral nerve injuries in, 384
 causalgia in, 478
- LEKSELL, L., 476
- LERICHE, R., 469, 474, 488
- Lethality of acute spinal cord wounds, 21
- LÉTIÉVANT, J. E. F., 303
- Levator scapulae, 308, 310
- Level of spinal cord injury:
 effect of, on work capacity, 187n
 relation of, to ambulation, 165
- LEWIS, L. G., 71, 87, 94
- LEWIS, T., 474
- Limited duty, after peripheral nerve injuries, 222, 223, 224
- Linen sutures, in peripheral nerve surgery, 388, 533

- Line-of-duty classification, of herniated nucleus pulposus, 194, 196, 201-202
- Lines of Langer, 322, 349
- Lipiodol myelography, 193, 198
- LISTER, J., 101, 303
- LIVINGSTON, K. E., 384, 469, 482
- Local analgesia, for—
 combined peripheral bone-nerve surgery, 422
 laminectomy, 26, 49-50, 51
 peripheral nerve repair, 211, 249, 368-369
 sciatic nerve surgery, 408
 suprapubic cystostomy, 62
- Local chemotherapy—
 at laminectomy, 56
 in acute spinal cord injuries, 35
 in primary nerve suture, 232
- Local injection of Novocain, in causalgia, 487-488
- Local measures in decubitus ulcers, 135-138, 140
- Local sulfonamide therapy, in peripheral nerve injuries, 234
- Localization, of—
 foreign bodies in spinal cord injuries, 39-40
 peripheral nerve injuries, 305-308
 returning sensation, in peripheral nerve injuries, 277
- Long bones, fractures of, associated with peripheral nerve injuries, 244-246
- Long thoracic nerve, 310
- Longus colli, 310
- LOUTZENHEISER, Lt. Col. J. J., 161
- LOVE, J. G., 193
- LOVETT, R. W., 256
- Lower extremity:
 bone shortening in, 380
 combined peripheral nerve-vascular injuries in, 439n, 455-458
 incidence of peripheral nerve injuries in 514
 irreparable peripheral nerve injuries in, 578-584
- LOWREY, Maj. J. J., 513
- Lumbar spinal cord, wounds of, 20, 38, 118
 case fatality rates in, 64, 115
- Lumbar nerves, formation of—
 femoral nerve from, 343
 sciatic nerve from, 350
- Lumbar plexus, 343
- Lumbar puncture—
 in acute spinal cord injuries, 38-39
 with myelography, 198
- Lumbar spine, pain on hyperextension of, in herniated nucleus pulposus, 196
- Lumbar spine, wounds of, 21, 29, 35, 47, 50, 59
- Lumboinguinal nerve, 349
- Lumbosacral spinal cord, wounds of, 19, 30, 115
- Lumbrical muscles, 328, 333, 337, 352, 401
 paralysis of, in median nerve injuries, 575-576
- Lungs, wounds of, 64
- LYONS, Capt. W. R., 220-221, 382, 495
- Lymphatic route of renal infection, 102
- MAKINS, G. H., 448, 455
- Malalinement, in irreparable peripheral nerve injuries of lower extremity, 570
- Malaria:
 effect of, in causalgia after peripheral nerve injuries, 481, 487
 in paraplegia, 146, 150
- Malar prominences, decubitus ulcers over, 131
- MALCOLM, Maj. D. C., 104
- Malecot tube, 97
- Malingering, suspicion of, in causalgia, 485, 486, 487n
- Malleolus, 252
- Malnutrition, in—
 causalgia, 480
 decubitus ulcers, 131, 142
See also Nutritional status.
- Malunion, in combined bone-peripheral nerve injuries, 423
- Management, of—
 acute spinal cord injuries, 31-65
 in ETOUSA, 25-30
 in general hospitals overseas, 32-65
 in MTOUSA, 20-23
 in World War I, 31, 304
 of catheter, in cord bladder, 91
 of causalgia, after peripheral nerve injuries, 487-489
 combined bone-peripheral nerve injuries, 245-246, 415-428
 cord bladder, 22, 30, 61-63, 86-100, 114-117, 119-125, 176
 in World War I, 3, 4, 90, 119
 decubitus ulcers, 6, 9, 10, 22, 29-30, 135-145
 epididymitis, 113
 fascicles at operation, 376-377, 381, 382, 395
 foreign bodies (bone fragments), at laminectomy, 52-54
 herniated nucleus pulposus, 194-202

- Management, of—Continued
 indwelling catheter, 6, 22, 62
 neurologic complications, in paraplegia, 6
 paraplegia, in ZI, 5-18, 127-191
 peripheral nerve injuries—
 at debridement, 228, 233-237
 in ETOUSA, 239-250
 in MTOUSA, 233-237, 247
 in World War I, 208-210, 231, 234
 on Continent, 249
 peripheral nerve injuries, principles of, 304-305
 periurethral abscess, 113
 priapism, 114, 173
 peripheral nerve-vascular injuries, 464-465
 renal calculi in paraplegia, 106-110
 renal infection in paraplegia, 103-104
 soft tissue-peripheral nerve wounds, 211, 242
 soft-tissue wounds, 231
 ureteral calculi, 111
 urethral fistula, 113
 urinary calculi, 152-153
 vesical calculi, 112
- Manometry, in paraplegia, 38, 182
- Manpower, losses, from herniated nucleus pulposus, 194
- Manual compression, in cord bladder, 61
- Manual examination, in peripheral nerve injuries, 213
- Manual expression of urine, 61, 89, 93, 124
- Manual of Military Urology*, 119
- Manual of Therapy, ETO*, 26-27, 242
- Marital status, of paraplegics, 128
- MARTIN, E. G., 256
- Massage, in peripheral nerve injuries, 247, 564
- Mass reflexes, in—
 acute spinal cord injuries, 38
 paraplegia, 162, 181
- MATAS, R., 465
- MATSON, Maj. D. D., 37, 44, 46, 50, 65, 130, 389
- Maxillofacial wounds, 49
- Maximum area of anesthesia, in peripheral nerve injuries, 267
- Maximum hospital benefits, in—
 paraplegia, 5
 peripheral nerve injuries, 221-222, 223-224
- Maximum voluntary pressure, in cord bladder, 79
- Mayer transplantation operation, 572
- McCouch, G. P., 68
- McCRAVEY, A., 46
- McDougall's sampling technique, 278
- McIntosh galvanic-faradic testing machine, 561
- Mechanism, of—
 pain in causalgia, after peripheral nerve injuries, 475-477
 spinal cord concussion, 35
 spinal cord injuries, 32-33
- Medial antebrachial cutaneous nerve, 310, 323, 330, 337, 340
- Medial anterior thoracic nerve, 310
- Medial bicipital groove, 321, 330
- Medial brachial cutaneous nerve, 308, 310, 322-323, 338, 395
- Medial calcaneus nerve, 352
- Medial condyle, 342, 343
- Medial cutaneous nerve, 394
- Medial epicondyle of humerus, 335, 338, 339, 340, 395
- Medial plantar nerve, 352
- Medial sural nerve, 359
- Median nerve, 323, 335, 337
 anatomy of, 328, 398
 assumption of ulnar nerve function by, 252
 autogenous grafting of, 493
 causalgia after injuries of, 414, 475
 contraindications to section of, in causalgia, 579
 deformity in causalgia, 482
 formation of, 308, 328
 injuries, 236, 328-335, 397, 398
 clawhand deformity after, 571
 closure of wound in, 330, 331, 333
 combined with bone injuries, 238, 416, 420
 combined with radial and ulnar nerve injuries, 338
 combined with ulnar nerve injuries, 576
 flexion-relaxation at operation for, 378
 frozen dried homografting in, 503
 positioning at operation for, 335
 repair of, 303, 394-399, 496-497
 repair of, in World War I, 210
 study of, by handprints, 265
 study of specimens from, 514
 techniques of gaining length in, 335
 innervation of thenar and flexor profundus muscles by, 263
 orthopedic surgery in irreparable injuries of, 569, 571, 576-578
 overlap of ulnar nerve into area of, 263-264

- Median nerve—Continued
 physiology of, 328, 333, 394, 396, 399
 regeneration, 264
 subclavian arterial involvement, in injuries of, 543
 surface anatomy of, 328–330
 surgical approach to injuries of, 330–333
 transplantation of, 335, 395, 396
- Medical care, in paraplegia, 13
- Medical corpsmen, in paraplegic program, 7, 8
- Medical Department of the United States Army in the World War*, 207, 210, 469
- Medical Department, United States Army, Surgery in World War II, Hand Surgery*, 571n
- Medical Director, VA, 14
- Medical Statistics Division, OTSG, 14
- Mediterranean Theater of Operations:
 acute spinal cord injuries in, 19–23
 herniated nucleus pulposus in, 202–203
 peripheral nerve injuries in, 211, 231–233, 239, 241, 244–246, 247, 249
- MEDLER, Capt. R. E., 116
- Meissner's end organs, 271n
- Membranous urethra, in cord bladder, 80
- Meningitis—
 after laminectomy, 58, 65
 in acute spinal cord injuries, 39, 43
 in paraplegia, 146
- Merthiolate, 52
- Metallic sutures, in peripheral nerve injuries, 224, 409
- Metatarsals, transplantation of extensor tendons of, 579
- Metycaine hydrochloride, 369
- Micro-Kjeldahl test, 149
- Middle cervical ganglia, 310
- Midtarsal arthrodesis, 582, 584
- Midtarsal joints, Lambrinudi operation on, 580
- Miller-Abbott tube, 63
- Mineral oil, effect of—
 in decubitus ulcers, 136–137
 in paraplegia, 156
 on fat-soluble vitamins, 150
- Minor causalgia, 473n, 475, 478, 479, 487
- MITCHELL, J. K., 489
- MITCHELL, S. W., 302, 303, 469, 473n, 474, 478, 479
- Mixed nerves:
 causalgia in, 475
 grafting of, 510
- MIXTER, W. J., 193, 195
- Mobilization, of—
 peripheral nerves, 207, 219, 305, 376
 radial nerve, 326
 ulnar nerve, 338, 339
- Modesto Junior College, 188
- Moisture, relief of causalgia by, 479, 480, 481
- Morale, of—
 casualties with combined bone-peripheral nerve injuries, 416
 paraplegics, 6, 150, 164, 190–191
 personnel in paraplegic program, 7, 8
- MOREHOUSE, G. R., 302, 469, 478, 479
- Morphine:
 for pain in paraplegia, 180
 in laminectomy, 49, 57–58
 preoperative administration of, in peripheral nerve surgery, 368
- Mortality, factors of, in acute spinal cord injuries, 64–65
- Motor cerebral cortex, 399
- Motor examinations, in peripheral nerve injuries, 254, 256
- Motor function, testing of, at debridement, 242
- Motor paralysis, in—
 causalgia after peripheral nerve injuries, 482, 489
 combined peripheral nerve-vascular injuries, 440
 peripheral nerve injuries, 253
- Motor branches, of femoral nerve, 349
- Motor power, assessment of, in peripheral nerve injuries, 251–252
- Motor testing, at—
 debridement, 242
 peripheral nerve surgery, 369, 375
- MULHOLLAND, J. H., 148
- MULLENIX, R. B., 77, 79
- Multiple nerve injuries, incidence of, 238
- MUNGER, A. D., 89, 95
- MUSCHAT, M., 74
- Muscle activity, in relation to peripheral nerve regeneration, 256
- Muscle atrophy:
 in combined bone-peripheral nerve injuries, 420
 in peripheral nerve injuries, 224, 245, 246
 test of, by handprint and footprint, 265–266
- Muscle contractures, in causalgia, 482
- Muscle deterioration, in peripheral nerve injuries, 272
- Muscle stamps, 57

- Muscle strength, quantitative assessment of, in peripheral nerve injuries, 256-263
- Muscle testing, in peripheral nerve injuries, 559-562
- Muscle tissue, management of, at peripheral nerve surgery, 370
- Muscle transplantation, in irreparable nerve injuries, 570, 579
- Musculocutaneous groove, 320, 323
- Musculocutaneous nerve, 328, 353
 anatomy of, 313-316, 393-394
 course of, 314
 exposure in injuries of, 316, 395
 formation of, 308, 313-314
 injuries of, 313-316, 416-420
 closure of, wound in, 316
 positioning at operation for, 314, 316
 repair of, 393-394
 study of specimens from, 514
 techniques of gaining length in, 316
 involvement of, in median nerve injuries, 394
 physiology of, 314
 surface anatomy of, 314
 surgical approach to injuries of, 314-316
- MUSE, Capt. W. T., 513
- Myelography, 193, 194, 195, 197-198
- MYERS, Capt. W. C., 513
- Nail changes, in causalgia, 481
- NASH, I. E., 89, 119
- Nasopharyngeal suction, after laminectomy, 58
- NATHAN, P. W., 93
- Nausea, in—
 renal calculi, 106
 renal infection, 102
- Naval casualties, cord bladder in, 94, 117
- Navy followup, of peripheral nerve grafts, 219n
- Neck:
 anatomy of, 441
 posterior triangle of, 305
 wounds of, 36
- NÉLATON, 303
- Nembutal, before laminectomy, 49
- Neostigmine bromide. *See* Prostigmin.
- Nephrectomy, 109-110
- Nephrostomy, 110
- Nerve block—
 as test of regeneration, of frozen dried homografts, 507
 in peripheral nerve injuries, 563
 in priapism, 114, 173
- Nerve block—Continued
 in quantitative testing, of muscle strength, 263-264
 to eliminate overlap sensation, in peripheral nerve injuries, 277
- Nerve crushing, in paraplegia, 9
- Nerve regeneration:
 after frozen dried homografting, 497, 499, 512
 after homogenous nerve grafting, 493, 494-495, 497
 after neurorrhaphy, 496
 after sympathectomy, 488
 in median nerve injuries, 264, 397
 in peripheral nerve injuries, 220-221, 223, 224, 243-244, 251-252, 256, 559
 combined with vascular occlusion, 458
 criteria of, 224-225
 experimental studies on, 302
 studies on, 219-221
- NESBITT, R. M., 91, 94
- Neurapraxia. *See* Contusion.
- Neurasthenia, as contraindication to work furlough, in peripheral nerve injuries, 223
- Neuraxes, downgrowth of, into distal nerve segment, 387
- Neurectomy, in—
 paraplegia, 173
 peripheral nerve injuries, 303
- Neuritis—
 after ulnar nerve injury, 342
 as cause of causalgia, 474
- Neuroanatomy, in peripheral nerve injuries, 220, 363
- Neurologic complications, in paraplegia, 6
- Neurologic examination, in—
 acute spinal cord injuries, 20, 36-38
 peripheral nerve injuries, 254-256
 wounds of extremities, 208
- Neurolysis, 231, 238, 239, 243, 244, 247, 374-375, 513
 after nerve grafting, 219n
 in brachial plexus injuries, 391, 392
 in causalgia after peripheral nerve injuries, 487
 in combined bone-peripheral nerve injuries, 245, 246, 422, 423, 425, 428
 in incomplete peripheral nerve injuries, 541, 547
 in neuroma in continuity, 521
 in sciatic nerve injuries, 409, 410
 in ulnar nerve injuries, 400
 in World War I, 210
 repetitions of, 375

- Neuroma:**
 in combined bone-nerve injuries, 422-423
 in continuity, 208, 211, 519-528, 538, 539, 547
 of suture line, 228-229
 pain in, 486
 resection of, 377, 380-381
 surgical management of, 375, 384
 suture of, 380-381
 traction on, 380
See also Pathologic process, Histologic process, etc.
- Neuroma formation—**
 after amputation, 478
 after frozen dried homografting, 509
 after median nerve repair, in hand, 399
 after primary nerve suture, 232
 in causalgia, 473
 in common peroneal nerve injuries, 413
 in complete peripheral nerve injuries, 518
 in musculocutaneous nerve injuries, 316
 in peripheral nerve injuries, 536, 537
 in radial nerve injuries, 326, 404, 405
 in sciatic nerve injuries, 409
- Neuromuscular changes, in peripheral nerve injuries, 557-559**
- Neuronal cytoplasm, effect of pressure wave on, 33**
- Neuropathologic studies—**
 in peripheral nerve injuries, 207, 211, 219-221, 244, 363, 513-555
 in World War I, 207, 219
 on tantalum sutures, 410
- Neurophysiology, 363**
- Neuropsychiatric Consultants Division, OTSG, 14**
- Neurorrhaphy, 240, 375-390**
 after frozen dried homografting, 499, 509
 in combined bone-peripheral nerve injuries, 422, 423-426, 428
 in combined skin-soft tissue-peripheral nerve injuries, 77, 429-438
 in painful injuries of lower extremities, 579
 timelag in, 514-515
See also Early nerve suture, End-to-end anastomosis, etc.
- Neurosurgical centers, 469, 568**
 causalgia in, 437n, 487
 in ETOUSA, 120
 in United Kingdom Base, 240, 241, 247
 in World War I, 208, 209
 in Zone of Interior, 123, 212, 221, 441, 470, 547
 management of paraplegics in, 127-191
- Neurosurgical centers—Continued**
 overseas, 547, 568
 training of personnel in electrodiagnosis in, 217
See also named and numbered general hospitals.
- Neurosurgical conditions, definition of, 25n**
- Neurosurgical personnel:**
 assignment of, 32, 241
 in paraplegic program, 122
 shortages of, 241-242
 training of, 241-242
- Neurotization—**
 after frozen dried homografting, 499, 505, 506, 508, 509, 510
 in nerve grafts, 547
See also Pathologic process, Histopathologic process, etc.
- Neurotmesis, 559**
- Neurovascular bundle, in—**
 arm, 330, 338, 343, 378, 394, 395
 axilla, 317, 322, 323, 338, 391, 402
- New York University College of Medicine, 147**
- Niacin, in paraplegia, 150**
- Ninety-day work furlough, in peripheral nerve injuries, 223-224**
- Ninth Service Command, 134**
- Ninth U.S. Army, 120**
- Nitrogen balance, in—**
 decubitus ulcers, 139-140
 paraplegia, 71
- Nitrogen losses, effect of, in development of decubitus ulcers, 148-149**
- Nocifensors, 474**
- Nondrainage management of cord bladder, 87-90, 99**
- Nonhemolytic streptococcal renal infections, in paraplegia, 103**
- Nonintervention method, in cord bladder, 61**
- Nonprotein nitrogen levels, in paraplegia, 129**
- Nonsurgical control, of pain in paraplegia, 180-181**
- Nonsurgical management, of spastic reflexes in paraplegia, 180-181**
- Nonunion, in combined bone-peripheral nerve injuries, 423**
- North African Campaign, 231**
- North African Theater of Operations. *See* Mediterranean Theater of Operations.**
- NURSE, M. M., 81, 94, 98, 117**

- Novocain analgesia, in—
 combined bone-peripheral nerve surgery, 422
 laminectomy, 50
 peripheral nerve repair, 249, 368
- Novocain block, in peripheral nerve injuries, 563
- Novocain reaction, death after, 250
- Novocain sympathetic block, in causalgia, 473n, 486, 488-490
- Numbness, in peripheral nerve injuries, 272
- Numerical expression of examination results, in peripheral nerve injuries, 251-253
- Nurses, in paraplegic program, 7
- Nursing care—
 after laminectomy, 48, 57
 in acute spinal cord injuries, 22, 23, 63
 in decubitus ulcers, 145
 in paraplegia, 6, 122, 124, 135, 139, 190
 during evacuation, 23, 134
 in World War I, 3
- Nutritional edema, in paraplegia, 149, 150
- Nutritional status, in paraplegia, 6, 12, 146-151
- Nylon sutures, in peripheral nerve surgery, 388, 533
- Objectives, of—
 diagnostic routine, in peripheral nerve injuries, 251, 252-253
 paraplegic program, 5-6
 Peripheral Nerve Registry, 226-227
- Objective techniques of testing, in peripheral nerve injuries, 213-217
- Obstruction, as cause of—
 renal calculi, 109
 renal infection, 103
- Obstruction, caused by calculi, 111
- Obstruction, of vesical neck, 124
- Obturator, 345
- Obturator internus, 351
- Obturator nerve:
 anatomy of, 407
 injuries of, 407
- Obturator neurectomy, 183
- Occupational therapy, in—
 paraplegic program, 11, 22, 122, 187
 peripheral nerve injuries, 566-567, 568
- Occupational training, in paraplegia, 185-186
- Occupations of paraplegics, 128
- Office of the Adjutant General, 14
- Office of the Chief Surgeon, ETOUSA, 29
- Office of the Surgeon General, 8, 14, 17, 18, 151n, 195, 197, 225, 226
 Consultant in Neurosurgery in, 127, 243
- Officer personnel, herniated nucleus pulposus in, 198-201
- Ointments, in decubitus ulcers, 137
- Okinawa, 7
- Olecranon process, 335, 340, 343
 decubitus ulcers over, 131
- Omohyoid, 308, 310
- Operating room setup, for peripheral nerve surgery, 364-365
- Operation:
 electrostimulation at, in peripheral nerve injuries, 19, 20, 311, 330, 346, 356, 365, 368, 369, 372-374, 375, 377, 392, 393, 395, 398, 403, 407, 521, 526, 541
 positioning at, in—
 axillary nerve injuries, 317, 318, 393
 brachial plexus injuries, 311, 313, 391, 392-393
 combined bone-peripheral nerve injuries, 423, 425
 femoral nerve injuries, 346, 350
 median nerve injuries, 330, 331, 346, 355, 394, 395, 395-397
 peripheral nerve injuries, 305, 365, 367, 384, 536, 539
 peroneal nerve injuries, 411
 posterior tibial nerve injuries, 359
 radial nerve injuries, 322, 323, 325, 326, 402, 404
 sciatic nerve injuries, 362, 408, 409, 425
 tibial nerve injuries, 412, 414
 ulnar nerve injuries, 338, 339, 340
 use of identification sutures at, 253, 364, 376, 384, 519
- Opponens paralysis, 225
- Opponens Pollicis, 328
- Orthopedic consultation, in—
 herniated nucleus pulposus, 195
 paraplegia, 22, 129
- Orthopedic management, of combined bone-nerve injuries, 244-246, 415-428
- Orthopedic preparation, in—
 combined bone-nerve surgery, 427
 peripheral nerve surgery, 367
- Orthopedic surgeons:
 direction of physical therapy by, in peripheral nerve injuries, 557
 role of:
 in paraplegic program, 122, 176, 190
 in peripheral nerve injuries, 209, 212, 224, 244-246, 415-428

- Orthopedic surgery, in—
 irreparable peripheral nerve injuries, 569–585
 paraplegia, 13
- Oscillometry, in causalgia, 474–475
- Osteomyelitis—
 associated with decubitus ulcers, 131
 in paraplegia, 146
 of pubis, 62
- Osteoporosis, in—
 causalgia, after peripheral nerve injuries, 474, 477–478, 485, 486
 paraplegia, 129, 147
- Osteotomy of metacarpals, 577
- Overflow bladder incontinence, in acute spinal cord injuries, 36, 61, 69, 70, 87–90, 99
 in female, 119
- Overlap areas, in peripheral nerve injuries, 252, 267–268
- Overlap compensation, in peripheral nerve injuries, 559
- Overlap muscle injuries, 266
- Overlap of ulnar nerve, into median nerve area, 264
- Overlap sensation, in peripheral nerve injuries, 277
- Overriding, of—
 clavicle, in brachial plexus injuries, 305, 313
 humerus, in peripheral nerve injuries, 380
- Oversea hospitals, Peripheral Nerve Registry in, 225, 226
- Pacific Ocean Areas, 7
- Pain and touch points, estimation of, in peripheral nerve injuries, 276
- Pain, in—
 acute spinal cord injuries, 35, 36, 49, 178–184
 causalgia, after peripheral nerve injuries, 470–473, 473n, 474–475, 476, 478–480, 485–487, 488, 489–490
 mechanism of, 475–477
 relation of trophic changes to, 481
 relation of vasomotor changes to, 481
 herniated nucleus pulposus, 196, 203
 incomplete peripheral nerve lesions, of lower extremity, 579
 paraplegia, 9, 10, 18, 178–184
 renal calculi, 105, 152
 renal infection, 102, 103
- Pain sensation, in peripheral nerve injuries, 273, 280
 quantitative estimation of, 273–274
 testing of, 266–272
- Pain threshold, in causalgia, 485
- Palmar cutaneous nerve, 331
- Palmaris—
 brevis, 337, 342
 longus, 328, 331, 574
 longus tendon, 328, 331, 333
- Pantopaque myelography, 193, 197–198
- Papaverine hydrochloride, in causalgia, 487
- Paradoxical vasoconstriction, in peripheral nerve injuries, 280
- Paraldehyde, after laminectomy, 57
- Paralysis:
 below knee, orthopedic surgery for, 579–580
 onset of, in spinal cord injuries, 35
- Paraplegia:
 according to branch of service, 127
 adjunct nutritional measures in, 150–151
 administrative policies in, 5–8
 age factor in survival in, 12–13n
 air evacuation in, 120, 134
 albumin-globulin ratio in, 149
 ambulation in, 5–6, 10, 15–16, 86, 87, 95, 110, 124, 139, 147, 152, 163, 164–173, 176, 179
 amputation in, 183–184
 amyloidosis in, 12n
 anemia in, 11
 anorexia in, 12, 146
 blood chemical studies in, 129
 blood replacement in, 150, 175
 blood studies in, 149, 150
 bowel function in, 6, 13, 151, 153–157
 braces in, 10, 13, 116, 162, 165, 167–168, 176, 177
 calculus formation in, 122, 129, 147, 152–153
 case fatality rates in, 12–13n, 123
 cathartics in, 153
 causes of death in, 11–12, 90
 changes of position in, 22, 23, 29, 108, 130–135
 civilian management of, 127
 crutches in, 13, 167–168
 cystometry in, 98
 cystoscopy in, 98
 debilitation in, 12, 131, 134
 decubitus ulcers in, 6, 9, 10, 13, 18, 22, 29–30, 71, 87, 89, 90, 99, 108, 119, 130–145, 146

Paraplegia—Continued

depression in, 17
 dietary management in, 9, 149-151, 175
 economic considerations in, 17
 emaciation in, 11
 emotional considerations in, 158-162
 epididymitis in, 112
 etiology of, 127-128
 euphoria in, 17
 evacuation in, 23, 27, 29, 30, 50-51, 120-121, 131-135
 family relations in, 16-17
 followup studies on, in VA, 187n
 footdrop in, 22
 furloughs in, 185
 general medical care in, 13
 hematocrit determinations in, 149
 history-taking in, 129
 impotence in, 114
 in civilian practice, 146
 laboratory examinations in, 129
 lack of resistance to infection in, 12
 mass reflexes in, 162
 neurologic complications in, 6
 nitrogen balance in, 71
 nursing care in, 122, 124, 135, 139
 during evacuation, 134
 in World War I, 3
 nutritional edema in, 149, 150
 nutritional status in, 6, 12, 146-151
 obturator nerve surgery in, 407
 occupational therapy in, 11, 12, 187
 occupational training in, 185-186
 orthopedic surgery in, 13
 pain in, 9, 10, 18, 36, 178-184
 personal hygiene in, 157-158, 165
 physical examination in, 129
 physical reconditioning in, 7, 10, 13-14, 162-164, 177
 physical therapy in, 7, 13, 32, 163, 180
 plasma protein levels in, 12, 147, 148, 149
 plasma transfusions in, 150-151
 plastic surgery in, 18
 post mortem examination in, 11-12
 prewar management of, 5
 priapism in, 38, 91, 101, 113, 173
 prognosis in, 15-17
 protein deficits in, 12, 145, 146, 147-150
 protein replacement in, 29, 150
 psychiatric factors in, 6, 146, 158-162, 186
 psychologic considerations of amputation in, 184
 psychologic testing in, 185
 psychotherapy in, 22-23

498991*—59—47

Paraplegia—Continued

rehabilitation in, 11, 61, 160, 184-186
 renal calculi in, 104-110
 renal infection from decubitus ulcers in, 102
 renal insufficiency in, 12n
 research in, 14
 roentgenologic examination in, 129, 182
 septicemia in, 12
 serum protein levels in, 149
 skin care in, 134, 135
 social factors in, 128-129
 somatic approach in, 6
 spastic reflexes in, 18, 178-184
 statistics of, 18, 30, 122-123, 127-129, 165, 187, 187n
 in VA hospitals, 12-13n
 studies on, in VA hospitals, 81n, 152n
 surgery in, 9, 13, 18
 urethrography in, 98
 urinalysis in, 72-73
 urinary tract complications in, 13, 18, 30, 70, 71, 86, 87, 146
 as cause of death, 114-115
 urologic management in, 6, 9, 13, 18, 29, 30, 67-125, 134, 151-153, 189
 vitamin supplements in, 150, 175
 vocational training in, 7
 weight loss in, 146
 wheelchair existence in, 5, 116
 work tolerance in, 16
See also Acute spinal cord injuries, injuries in special parts of spine, etc.

Paraplegic centers:

physical specifications for, 8, 9, 13-14, 17
 recordkeeping in, 153, 163, 173, 177, 178, 189n

surveys of, 6-7, 8-11

Paraplegic program, 5-18, 127-191

chaplains in, 190
 conferences on, 6, 7-8, 13-14, 127, 133-134, 161, 184
 equipment for, 8, 9
 hospital conferences in, 6
 hospital organization in, 6, 163
 medical corpsmen in, 7, 8
 nurses in, 7
 objectives of, 6
 personnel in, 6-8, 11, 13-14, 17-18, 122, 189-190
 physical therapists in, 7, 189
 physician-patient relations in, 188-190
 results of, 186-188
 transfer of, to VA, 5, 7, 13-18, 123

- Paraplegic program—Continued
 vocational instructors in, 190
 WAC's in, 7-8
- Paraplegics:
 beds for, 8
 continuation of education by, 17, 185-186
 educational level of, 7, 17, 129
 family care of, 15, 16-17, 160
 indications for transfer of, to VA, 5, 13-14
 management of, in ZI hospitals, 127-191
 morale of, 6, 150, 164, 190-191
 previous occupations of, 128
 rating of, in AGCT, 129, 160, 186
 recreation for, 184-185
 survey of, in ZI hospitals, 14-17, 127-129, 160, 186
- Paravertebral block, in paraplegia, 180, 181
- Paresthesia—
 after frozen dried homografting, 503
 in acute spinal cord injuries, 37
 in herniated nucleus pulposus, 196
 in irreparable peripheral nerve injuries, 580
 in peripheral nerve injuries, 272
 in ulnar nerve injuries, 576
- PARKER, Lt. Col. J. M., 238
- Partial nerve suture, 376-377
- Partial spinal cord injuries. *See* Incomplete transection of spinal cord.
- PASTEUR, L., 303
- Patella:
 decubitus ulcers over, 131
 resection of, in combined injuries, 426
- Pathologic anatomy, in peripheral nerve injuries, 370-372
- Pathologic fractures, in paraplegia, 147
- Pathologic physiology, in—
 cord bladder, 67-71
 peripheral nerve injuries, 269
 spinal cord injuries, 32-33
- Pathologic process, in—
 acute spinal cord injuries, 32-34
 brachial plexus injuries, 391
 causalgia, after peripheral nerve injuries, 473-474
 combined peripheral nerve-vascular injuries, 465
 combined radial nerve-humerus injuries, 403
 decubitus ulcers, 59, 131
 infection, in paraplegia, 11
 median nerve injuries, 394
 peripheral nerve injuries, 304, 557-559
 combined with vascular occlusion, 458
 peripheral nerve-vascular injuries, 454
- Pathologic process, in—Continued
See also Histopathologic process, Fibrosis, Neurotization, etc.
- PATTERSON, Col. R. H., 7, 8
- Pectineus, 344, 350
- Pectoralis—
 major, 310, 317, 328, 338, 391, 392, 393
 minor, 310, 392
- Pedicle flaps, in combined peripheral nerve-skin-soft tissue injuries, 421, 429, 430-432
- Pelvis, exposure of femoral nerve injuries in, 346-349
- Penalgnesia, 269
- Penetrating wounds—
 as cause of causalgia, 475
 in gluteal area, 354
 of spine, 33, 35, 38-39
- Penicillin, in—
 acute spinal cord injuries, 35, 39
 combined peripheral nerve-bone injuries, 254, 421, 427
 decubitus ulcers, 137, 138, 140
 epididymitis, 113
 peripheral nerve injuries, 234
 periurethral abscess, 113
 postlaminectomy meningitis, 58, 65
 primary nerve suture, 232
 renal infection, 103, 104
 urinary tract complications, of spinal injuries, 22, 125
- Penile turgescence, 38
- Penoscrotal abscess, 113
- Penoscrotal fistula, 90-91, 97
- Pentobarbital sodium. *See* Nembutal.
- Pentothal sodium anesthesia, for—
 laminectomy, 50
 peripheral nerve surgery, 369
- Perforating wounds, of—
 hollow viscera, 147
 spine, 33
- Periarterial neurectomy, 488
- Perineal urethrostomy, 62, 97
- Perineurial fibrosis, 374
- Peripheral nerve-bone injuries, 232, 242, 244-246, 247, 304, 415-428, 558, 563, 564
 in World War I, 208
 physical therapy in, 563, 564
- Peripheral Nerve Commission, in World War I, 209
- Peripheral nerve concussion, 465
- Peripheral Nerve Conference, 230
- Peripheral nerve contusion, 253, 454, 465, 550, 588-589

- Peripheral nerve ends:
 preparation of, for suture, 382-383
 visualization of, at debridement, 242
- Peripheral nerve fibers, interaction of impulses between, 476
- Peripheral nerve grafts, 218-219, 229, 236, 375-376, 381-382, 390, 493-512, 547
 end-to-end anastomosis after, 219n, 376
 histopathologic studies on, 543-555
 In World War I, 219, 493
 plaster fixation after, 570
 registration of, in Peripheral Nerve Registry, 226-228
 statistics of, 218-219, 219n
- Peripheral nerve injuries, 207-585
 administrative considerations in physical therapy in, 557
 assessment of sensory status in, 251-252
 bone shortening in, 305, 496
 causalgia after, 469-492
 civilian type of, 363-364
 classification of, 363-364
 combined with vascular occlusion, 458-464
 compass test in, 277-279
 complicated by other injuries, 241
 delayed primary wound closure in, 242, 252, 562, 563
 determination of superficial pressure in, 275-276
 diagnosis of, 251-300
 diagnostic procedures in, 212-217
 disposition in, 221-225, 241
 early motion in, 562-563
 edema in, 562, 563, 564, 565
 electrodiagnosis in, 251, 266, 560-562, 567
 evacuation of casualties with, 240-241
 evaluation of, at operation, 372-374
 evolution of, management of, 211-230, 231-237, 239-247
 experimental studies on, 207, 211, 218, 219, 239, 243, 246, 302, 381, 495, 515, 557, 564, 566
 followup in, 221-230
 in Peripheral Nerve Registry, 225-230
 histopathologic process in, 239, 513-555
 historical note on, 207-210, 301-304
 history-taking in, 253-254
 hospitalization policies in, 221-225
 in Civil War, 302-303
 in civilian practice, 239
 in ETOUSA, 211, 239-250
 in MTOUSA, 211, 231-238, 239, 241
 in paraplegics, 146
 in Sino-Japanese War, 302
- Peripheral nerve injuries—Continued
 in World War I, 207-210, 225, 231, 301, 302, 303-304
 incidence of, 128, 194, 194n, 211, 212, 225, 493
 initial wound surgery in, 31, 208, 233-237, 242-243, 250, 304-305, 364, 376, 403
 joint changes in, 558, 562-563, 565
 late exploration in, 239
 localization of, 305-308
 localization of returning sensation in, 277
 management of, 251-585
 muscle testing in, 559-562
 neurologic examination in, 254-256
 neuromuscular changes in, 557-559
 objectives of examination in, 252-253
 occupational therapy in, 566-567, 568
 orthopedic surgery in irreparable types of, 569-585
 pathologic process in, 219-221, 239, 304, 513-555, 557-559
 physical therapy in, 1, 5-9, 209, 223, 224, 245, 246-247, 250, 557-568
 physiologic pathology of, 557-559
 postoperative management in, 244, 426-428, 431, 498
 preoperative preparation in, 365-367
 primary suture in, 222, 228, 231-233, 239, 242, 303, 415
 principles of management of, 208, 211-212, 233-237, 242-244, 304-305
 priority of evacuation in, 222, 240
 psychologic factors in, 567
 records in, 242-243, 253-256, 259, 261-263, 273, 274, 275-276, 277, 278-279, 282, 364, 557, 560
 at Cushing General Hospital, 254-256
 regeneration in, 219-221, 223, 224-225, 243-244, 251-252, 256, 264, 302, 397, 458, 488, 493, 494-495, 496, 497, 499, 512, 559
 roentgenologic examination in, 224, 242, 243, 254, 376, 389
 sensory patterns in, 212, 213-217
 sensory testing in, 266-272
 skin temperature tests in, 280-282
 splinting in, 235, 236-237, 242, 246, 420-421, 563, 565-566
 spontaneous regeneration in, 211, 224, 239, 253, 301, 373-374, 448
 statistics of, in—
 ETOUSA, 237-238
 MTOUSA, 247-250
 Peripheral Nerve Registry, 228-229

- Peripheral nerve injuries—Continued
 stretch fibrosis in, 541-543, 558
 supplementary motor movements in, 212
 suture material in, 388-389, 533-535
 sweat tests in, 279-280
 symptoms of, 280
 techniques of—
 examination in, 251-300
 physical therapy in, 562-568
 repair in, 242-244, 246, 249, 301-467
 timing of surgery in, 211, 231, 233, 234, 235, 239-242, 363-364, 375, 515, 519, 531-533
 Tinel's sign in prognosis of, 212-213, 224, 272-273, 428, 519, 531, 547, 555
 trick movements in, 261, 263-264, 568
 unnecessary exploration in, 243
 vascular changes in, 558, 559
 vasomotor disturbances in, 562
 work furloughs in, 223-224, 254, 268
 wound infections in, 241, 246
See also special nerves, special injuries, special combinations of injuries, etc.
- Peripheral nerve-joint injuries, 304
 Peripheral nerve laboratories, 212
 Peripheral nerve lesions, in continuity, 219, 237-238
 Peripheral nerve regeneration. *See* Pathologic process, Histopathologic process, Neurotization, etc.
Peripheral Nerve Regeneration, 213n, 230, 439, 495n
 Peripheral Nerve Registry, 211, 221, 223, 225-230, 381, 439, 463
 in World War I, 209-210
 Peripheral nerve repair:
 disruption of suture line after, 228, 243, 244, 416, 519, 533, 539-541
 techniques of, 363-428
 Peripheral nerve resection, in causalgia, 488, 579
 Peripheral nerve-soft tissue injuries, 211, 242, 253, 429-438
 in World War I, 208
 Peripheral nerve surgery:
 anesthesia for, 368-369
 setup of operating room for, 364-365
 positioning at, 305, 311, 313, 314, 316, 317, 318, 330, 331, 335, 346, 350, 354, 359, 393, 394, 395, 402, 404, 408, 409, 411, 412-414, 423, 424, 430, 536, 539
 Peripheral nerve suture, failures of, 228-229, 236
 Peripheral nerve-tendon injuries, 304
 Peripheral nerve transplantation, 207, 219, 236, 243, 305, 379-380, 536, 547, 550, 551
 Peripheral nerves:
 anatomic approaches to, 301-362
 erosion of, by aneurysms, 519, 528-530
 mobilization of, 207, 219, 305
 Periurethral abscess, 90, 97, 113, 122
 Peroneal artery, 352
 Peroneal component, of sciatic nerve, 410
 Peroneal nerve:
 anatomy of, 407, 409-410, 581
 autogenous grafting of, 494
 injuries of:
 equinus (equinovarus) deformity after, 580
 failures of suture of, 581
 Lambrinudi operation after, 580
 orthopedic surgery after, 581-584
 study of, by footprints, 266
 irreparable injuries of, 581-584
 Peroneal nerve-vascular injuries, 455
 Peroneal palsy, 407-408
 Peroneus—
 brevis, 353, 361
 longus, 353, 358, 362
 tertius, 353
 Personal hygiene, in paraplegia, 157-158, 165
 Personality changes, in causalgia, after peripheral nerve injuries, 482, 485
 Personnel Division, OTSG, 18
 Personnel, in—
 paraplegic program, 6-8, 11, 13-14, 17-18, 122, 189-190
 shortages of, 7
 training of, 6-8
 peripheral nerve program:
 in physical therapy sections, 568
 training of, in electrodiagnosis, 217
 PETROFF, Maj. B. P., 9, 84, 85, 102, 103, 104, 116
 Petrolatum-impregnated ointments, in decubitus ulcers, 137, 138
 Phantom limb, 477-478, 486, 487
 Phenolsulfonphthalein test, in cord bladder, 124
 PHILLIPEAUX, 303
 Phosphomolybdic acid-aniline blue mixture, 514, 518
 Phosphorus blood levels, in paraplegia, 129
 Photomicrography, in peripheral nerve injuries, 221, 515-516, 526
 Phrenic nerve, 312
 Physical examination, in paraplegia, 129

- Physical stimuli, in causalgia, after peripheral nerve injuries, 479, 482-485
- Physical therapists, in paraplegic program, 7, 18, 122, 189, 568
- Physical therapy:
- after tibialis posticus transplantation, 584
 - diagnostic use of, in peripheral nerve injuries, 1, 5-9, 213, 557, 559-562, 568
 - effect of, in causalgia, 470
 - in combined bone-peripheral nerve injuries, 245, 250, 420, 421, 426
 - in median nerve injuries, 398
 - in paraplegia, 7, 13, 22, 163, 180
 - in peripheral nerve injuries, 223, 224, 246-247, 557-568
 - in World War I, 209
 - psychologic factors in, 557, 564, 568
 - techniques of, in peripheral nerve injuries, 562-568
- Physician-patient relations, in paraplegic program, 188-190
- Physiologic basis, of—
- compass test in peripheral nerve injuries, 277-278
 - nerve suture, 303
- Physiologic pathology, in—
- acute spinal cord injuries, 45, 169-170
 - median nerve injuries, 576-577
 - peripheral nerve injuries, 1, 2-4, 557-559
 - radial nerve injuries, 573-575
- Physiologic salt solution, injection of, into distal nerve segment, 374, 384
- Physiology, of—
- axillary nerve, 317
 - bladder, 80
 - brachial plexus, 308, 311
 - cauda equina, 182
 - deep peroneal nerve, 353
 - femoral nerve, 344-345
 - lateral plantar nerve, 353
 - medial plantar nerve, 352
 - median nerve, 328, 333, 394, 396, 397, 399
 - musculocutaneous nerve, 314, 353
 - proper volar digital nerve, 333
 - radial nerve, 320, 326, 399
 - sural nerve, 352
 - ulnar nerve, 340
 - upper extremity, 304-305
- PICKERING, G. W., 474
- PILCHER, C., 34
- Pinch grafts, in decubitus ulcers, 143
- Piperocaine hydrochloride. *See* Metycaine hydrochloride.
- Piriformis, 350, 356, 409
- Pisiform bone, 335, 340, 342
- Pitressin, 63
- PLAGGEMEYER, H. W., 80
- Plantar fasciotomy, 579
- Plantar response, in acute spinal cord injuries, 38
- Plantar ulcers, 570
- Plantaris, 352
- Plasma:
- local application of, to decubitus ulcers, 30
 - protein levels, in paraplegia, 12, 147, 148, 149
 - replacement, of protein deficits, in paraplegia, 150-151
 - transfusion after laminectomy, 57
 - in acute spinal cord injuries, 36, 63
 - in combined bone-peripheral nerve injuries, 421
 - in paraplegia, 150-151
 - in renal infection, 103
- Plasma clot anastomosis, in peripheral nerve surgery, 389-390
- Plasma clot sheath, in peripheral nerve surgery, 243
- Plasma glue technique, of nerve grafting, 498
- Plaster fixation:
- after combined bone-peripheral nerve surgery, 422, 564
 - after combined peripheral nerve-plastic surgery, 431
 - after femoral nerve surgery, 407
 - after combined peripheral nerve-tibial surgery, 421
 - after frozen dried homografting, 498
 - after peripheral nerve surgery, 366-367, 384, 563, 566
 - after peroneal nerve surgery, 581
 - after sciatic nerve surgery, 409
 - after tibialis posticus transplantation, 584
 - muscle changes caused by, in peripheral nerve injuries, 558
 - risks of, in combined peripheral nerve-vascular injuries, 464
- Plaster shells, in evacuation of paraplegics, 22, 23
- Plaster shoulder spicas, in combined bone-peripheral nerve surgery, 404
- Plastic repair, of soft-tissue injuries, 241
- Plastic surgeons, cooperation of, in peripheral nerve injuries, 224-225, 429-432
- Plastic surgery, in—
- combined bone-peripheral nerve injuries, 246

- Plastic surgery, in—Continued
 combined peripheral nerve-skin-soft tissue injuries, 429-438
 decubitus ulcers, 9-10, 131, 135
 paraplegia, 18
 peripheral nerve injuries, 304
 periurethral abscess, 113
- PLATTI, J. T., 193
- PLATT, H., 207, 303, 305
- Pneumonitis, in paraplegia, 146
- POER, Col. D. H., 189
- Poliomyelitis, 558
- POLLOCK, L. J., 207, 213, 256, 265, 273, 303, 441, 470, 489, 561
- POOL, Lt. Col. J. L., 37, 43, 44, 65, 130
- Popliteal nerve injuries, in World War I, 210
- Popliteal space, 351, 353, 357-359, 361
 combined peripheral nerve-vascular injuries in, 455
 exposure of common peroneal nerve below, 360-362
 exposure of common peroneal nerve in, 357-359
 exposure of tibial nerve in, 357-359
- Popliteal vessels, 351, 358
- Popliteus, 351, 352, 358
- Position sense, in peripheral nerve injuries, testing of, 266-272
- Positioning, after laminectomy, 58-59
- Positioning, at operation for—
 axillary nerve injuries, 314, 317, 318, 393
 brachial plexus injuries, 311, 313, 391, 392-393
 combined bone-peripheral nerve injuries, 423, 425
 combined peripheral nerve-plastic surgery, 430
 combined sciatic nerve-femoral injuries, 425
 femoral injuries, 346, 350
 median nerve injuries, 330, 331, 335, 394, 395, 396-397
 musculocutaneous nerve injuries, 316
 peripheral nerves injuries, 305, 365, 367, 378-379, 536, 539
 peroneal nerve injuries, 411
 posterior tibial nerve injuries, 359
 radial nerve injuries, 322, 323, 325, 326, 402, 404
 sciatic nerve injuries, 354, 362, 408, 409
 spinal cord injuries, 50, 51
 tibial nerve injuries, 412, 414
 ulnar nerve injuries, 338, 339, 340
- Positioning of paraplegics, for—
 transportation, 29, 35
 defecation, 155
- Positive pressure anesthesia, 51
- Posterior bone blocks, in irreparable peripheral nerve injuries, 580
- Posterior brachio-cutaneous nerve, 320
- Posterior cervical triangle, 308, 310
- Posterior femoral cutaneous nerve, 356
- Posterior interosseous, 405
- Posterior interosseous artery, 320, 326
- Posterior interosseous nerve, 405
- Posterior tibial artery, 352, 413
- Posterior tibial nerve, 325, 353
 anatomy of, 352-353
 causalgia after injuries of, 414
 closure of wound in injuries of, 359
 exposure of, 359
 grafting of, 546
 repair of injuries of, 412-414
 study of specimens from, 514
- Posterior tibial vessels, 352, 359, 413
- Posterior triangle of neck, 305
- Post mortem examinations, in paraplegia, 11-12
- Post mortem studies, in herniated nucleus pulposus, 194
- Postoperative case fatality rates, in acute spinal cord injuries, 65
- Postoperative complications, in combined bone-peripheral nerve injuries, 426-428
- Postoperative management—
 after combined peripheral nerve-plastic surgery, 431
 after frozen dried nerve grafting, 498
 after laminectomy, 48-49, 57-61
 after peripheral nerve surgery, 244
 in decubitus ulcers, 145
- Posttraumatic dystrophies, 477-478
- Potassium permanganate solutions, for bladder irrigations, 94
- Potentiometric skin temperature test, 281
- POTTER, Capt. S. E., 389, 513
- Potter-Croce technique, in combined bone-peripheral nerve injuries, 421, 430-431
- Poupart's ligament, 344, 346
- POWELL, V. E., 279
- PRATHER, Lt. Col. G. C., 72, 79, 80, 84, 85, 102, 103, 104, 110, 112, 116, 117
- Preganglionic dorsal sympathectomy, 488-489
- Preinduction herniated nucleus pulposus, 194, 196-197, 200

- Preoperative evaluation, of—
 femoral nerve injuries, 407
 peripheral nerve injuries, 365-366
- Preoperative exercises, in—
 peripheral nerve injuries, 305
 sciatic nerve injuries, 362
- Preoperative infection, in combined bone-peripheral nerve injuries, 426-427
- Preoperative management, of combined bone-peripheral nerve injuries, 420-421
- Preoperative medication, before—
 laminectomy, 49
 peripheral nerve surgery, 368
 surgery, in decubitus ulcers, 139-140
- Preoperative preparation, in peripheral nerve injuries, 365-367
- Preparation of surgical field, for laminectomy, 51-52
- Prepared bed technique, in frozen dried homografting, 498, 508-509
- Presacral nerve, resection of, in cord bladder, 122
- Pressure points, protection of:
 after laminectomy, 59
 in acute spinal cord injuries, 63
 in decubitus ulcers, 131
- Pressure waves, effects of, in concussion spinal cord injuries, 33
- Prevention of—
 complications, in acute spinal cord injuries, 35
 decubitus ulcers, 6, 23, 29-35, 51, 59, 134-135, 155
- Priapism, 38, 91, 101, 113, 173
- Primary nerve suture, 228, 231-233, 242, 303, 415
 in civilian injuries, 239
 in World War I, 208
 statistics of, 232-233
- Primary wound healing, in peripheral nerve injuries, 249
- Principles of early nerve suture, 208, 211-212, 233-237, 242-244, 304-305
- Priority of evacuation, in—
 acute spinal cord injuries, 26, 240
 head injuries, 240
 paraplegia, 133, 134
 peripheral nerve injuries, 222, 240
- Procaine hydrochloride. *See* Novocain.
- Profunda artery, 320, 323, 325
- Prognosis, in—
 acute spinal cord injuries, 21, 25, 26-27, 31, 33, 37, 55
 ambulation in paraplegia, 169
- Prognosis, in—Continued
 combined peripheral nerve-vascular injuries, 442-443, 458, 463
 combined vascular-cranial nerve injuries, 447-448
 herniated nucleus pulposus, 197
 incomplete transection of spinal cord, 45
 paraplegia, 15-17
 peripheral nerve injuries, 272-273
 radial nerve injuries, 573
 sciatic nerve injuries, 362
 spinal cord concussion, 47
 ulnar nerve injuries, 575-576
- Pronation deformity, in radial nerve injuries, 575
- Pronator—
 quadratus, 328
 radii teres, 574
 teres, 328, 331, 335, 343, 397
- Prone position, in transportation of paraplegics, 29
- Proper volar digital nerves, 333
- Prophylactic antimicrobial therapy, in—
 acute spinal cord injuries, 22
 cord bladder, 32
- Proprioceptive power, 169
- Prostatic complications of cord bladder, 97, 112
- Prostatic urethra, in cord bladder, 80-81, 82, 85
- Prostigmin bromide, 63
- Protection, of—
 flexion creases at operation, 328, 401, 406, 411
 suture line after peripheral nerve repair, 243, 386-388
- Protein deficit, in—
 decubitus ulcers, 9, 10, 63, 135, 145, 146, 147-150
 paraplegia, relation of infection to, 12, 144-149
- Protein hydrolysates, 151
- Protein replacement, in paraplegia, 29, 150
- Protein-sparing diet, in paraplegia, 150
- Protein supplements, in combined bone-nerve injuries, 421
- Proteus vulgaris* renal infections, in paraplegia, 72, 102-103
- Proximal segment, management of, in peripheral nerve surgery, 382-383
- Pseudomonas aeruginosa* infection, in paraplegia, 72, 103
- Pseudomonas* infection, in decubitus ulcers, 137, 140

- Psoas, 343, 344, 346, 347, 350
 Psoas abscess, in paraplegia, 146
 Psychiatric care, after laminectomy, 59-61
 Psychiatric factors, in paraplegia, 158-162
 Psychogenic factors, in causalgia, after peripheral nerve injuries, 482-485, 486, 488
 Psychologic factors, in—
 paraplegia, 6, 146, 184, 186
 peripheral nerve injuries, 567
 physical therapy, in peripheral nerve injuries, 557, 564, 568
 Psychologic testing, in paraplegia, 185
 Psychoneurosis:
 as contraindication to work furlough, in peripheral nerve injuries, 223
 relation of, to causalgia, 478
 Psychotherapy, in paraplegia, 22-23
 Pubis:
 infection of, in suprapubic cystostomy, 97
 osteomyelitis of, 62
 Pulmonary complications, in acute spinal cord injuries, 32
 Pulmonary edema, as cause of death, in acute spinal cord injuries, 65
 Pulsating hematoma, in combined peripheral nerve-vascular injuries, 440
 Pyelitis, in paraplegia, 72, 73
 Pyelography, 106
 Pyelonephritis, 101, 146
 Pyonephrosis, 110
 Pyuria, in paraplegia, 72
- Quadratus lumborum, 343
 Quadriceps—
 exercises, after femoral nerve surgery, 407
 paralysis of, 579
 Quadrilateral space of Velpeau, 317, 318, 393
 Quadriplegia, 12-13n
 Qualitative determination, of—
 areas of impaired sensation, in peripheral nerve injuries, 273
 returning sensory function, 272-273
 Qualitative examinations, in peripheral nerve injuries, 254
 Quantitative assessment, of muscular strength, in peripheral nerve injuries, 256-263
 Quantitative determinations, of—
 pain sensation, in peripheral nerve injuries, 273-274
 superficial pressure (touch), in peripheral nerve injuries, 275-276
 Quantitative estimation, of recovery, in peripheral nerve injuries, 213
- Quantitative examinations, of motor function, in peripheral nerve injuries, 256
 Queckenstedt test, 26, 38, 182
- Radial crease, 333
 Radial extensor muscles, 321
 Radial nerve: 317, 323
 anatomy of, 318-321, 404-405, 573
 assumption of ulnar nerve function by 252
 branches of, 320, 321
 cable sural autograft of, 546-547
 course of, 318-320
 formation of, 308, 328
 injuries of, 318-327, 541-543
 associated with bone injuries, 238, 256, 416-420, 573, 574
 bone shortening in, 380, 404
 closure of incision in, 322, 323, 325, 326
 flexion-relaxation at surgery for, 378
 positioning at operation for, 322, 323, 325, 326
 prognosis in, 573
 repair of, 401-406
 study of, by handprints, 266
 study of specimens from, 514
 surgical approach to, 322-326
 techniques of gaining length in, 326
 irreparable injuries of, 573-575, 581
 physiology of, 320, 326, 399
 surface anatomy of, 321
 transplantation of, 326, 403-404, 423, 428
 Radiopacity of tantalum, 380, 389
 Radius:
 bicipital tubercle of, 331
 fracture of head of, 405
 fractures of, associated with—
 peripheral nerve injuries, 328, 420
 radial nerve injuries, 326
 resection of head of, in combined bone-nerve injuries, 423
 Radius and ulna, peripheral nerve, injuries associated with fractures of, 238
 RAINES, Maj. S. L., 102, 103, 112
 RAMÓN Y CAJAL, 514
 Rank, relation of paraplegia to, 128
 RANKIN, Brig. Gen. F. W., 5, 8, 195, 225
 RAPPAPORT, Capt. H., 11, 12
 RASMUSSEN, Lt. Col. T. B., 473n
 Reaction, to—
 Pantopaque myelography, 198 sutures, in peripheral nerve injuries, 533-535
 Reconditioning centers, causalgia in, 470
 Reconditioning, in paraplegia, 7, 10, 13-14, 164, 177

- Reconditioning system, effect of, in herniated nucleus pulposus, 201
- Records, at spinal operations, 51
in acute spinal cord injuries, 38
in decubitus ulcers, 135
in paraplegic centers, 130, 153, 163, 173, 177, 178, 189n
in peripheral nerve injuries, 299, 233, 238, 242-243, 253, 256, 259, 261-263, 273, 274, 275-276, 277, 278-279, 282, 364, 560, 557
at Cushing General Hospital, 254-256
of Peripheral Nerve Registry, 225-228
in World War I, 209
- Recreation, for paraplegics, 184-185
- Recumbency, as cause of renal calculi, 104-105
- Recurrence of—
causalgia, after peripheral nerve injuries, 490
renal calculi, in paraplegia, 108, 110
- Recurrent tibial nerve, 353
- Red blood bell paste, in decubitus ulcers, 137-138
- Reduction of fractures, in combined bone-peripheral nerve injuries, 245
- Reeducation of transplanted muscles, 577
- Reexploration, after—
definitive peripheral nerve surgery, 547
frozen dried homografting, 498, 499-501
- Reflex arc, in bladder wall, 69, 71
- Reflex automatic bladder, 13, 63, 67, 69, 70, 71, 79, 121, 123, 176
after intermittent catheterization, 114
after tidal drainage, 115-117
cystography in, 81-82, 83-84
development of, 61-63, 76-79, 93
effect of drugs on, 94
effect of level of injury on, 117-118
noncatheter achievement of, 89
renal function in, 100
resection of bladder neck in, 97-98, 99, 117, 122, 124, 125
urethrography in, 85
- Reflex paralysis, in causalgia, after peripheral nerve injuries, 489
- Reflex responses, in acute spinal cord injuries, 38
- Reflexes, suppression of, after acute spinal cord injuries, 68, 74
- Refracture, in combined peripheral bone-nerve injuries, 423, 425
- Regional anesthesia, in peripheral nerve surgery, 369
- Regional consultants in neurosurgery, in ETOUSA, 241
- Regional distribution, of combined peripheral nerve-vascular injuries, 439
- Regional incidence—
combined bone-peripheral nerve injuries, 246
peripheral nerve injuries, 237
- Regrafting with frozen dried homografts, 498
- Rehabilitation of paraplegics, 6, 11, 61, 160, 184-186
- Rehydration of frozen dried homografts, 496
- Removal suture technique, in peripheral nerve surgery, 389
- Renal calculi in paraplegia, 104-110
management of, 106-110
recurrence of, 108-110
surgery in, 108-110
- Renal complications, of cord bladder, 101-110
- Renal function studies, in cord bladder, 124
- Renal infection:
antimicrobial therapy in, 103-104
associated with calculi, 106-108, 110, 111
diagnosis of, 102-103
in acute spinal cord injuries, 101, 104
surgery in, 125
- Renal insufficiency, in paraplegia, 12n
- Repair, of—
axillary nerve injuries, 393
brachial plexus injuries, 391, 393
combined bone-nerve injuries, 245, 415-428
digital nerve injuries, 399
femoral nerve injuries, 406-407
median nerve injuries, 394-399
in World War I, 210
musculocutaneous nerve injuries, 393-394
obturator nerve injuries, 407
peripheral nerve injuries, in relation to type of wound, 363-364
peroneal nerve injuries, 411-412
popliteal nerve injuries, in World War I, 210
radial nerve injuries, 401-406
sciatic nerve injuries, 407-410
in World War I, 210
tibial nerve injuries, 412-414
ulnar nerve injuries, 395, 396-397, 400-401
in World War I, 210
- Replacement therapy, in—
acute spinal cord injuries, 36
peripheral nerve surgery, 367
renal infection, 103

- Resection, of—
 bladder neck, in paraplegia, 97-98, 99, 117, 122, 124, 125
 clavicle in brachial plexus injuries, 392
 damaged nerve ends, 220, 221, 229, 234, 235-236, 239, 243, 364, 374, 382-383, 421, 425
 at primary nerve suture, 232
- Resection, of—
 gliomas, 277, 380-381
 head of fibula, 362, 410
 head of radius, 405, 423
 incomplete nerve lesions in causalgia, 476, 488
 neck of fibula, in peroneal nerve surgery, 411
 neuromas, 377, 380-381
 patella, in combined sciatic nerve-knee joint injuries, 426
 presacral nerve, in cord bladder, 122
 synostosis, of radius and ulna, 424
- Resectoscopic removal of vesical calculi, 97-98, 112
- Residual urine. *See* Cystometry.
- Resistance exercises, in peripheral nerve injuries, 567
- Resistance to infection, in paraplegia, 12
- Respiration, during laminectomy, 51
- Respiratory collapse, in vascular-cranial nerve surgery, 448
- Respiratory depression, in acute spinal cord injuries, 49, 50, 58
- Respiratory failure as cause of death, in acute spinal cord injuries, 64
- Results, of—
 axillary nerve repair, 393
 closure of decubitus ulcers, 142-143
 combined bone-peripheral nerve surgery, 427, 428
 frozen dried homografts, 499-512
 initial orthopedic surgery in combined bone-peripheral nerve injuries, 245
 instruction in ambulation, in paraplegia, 172-173, 176, 178
 median nerve repair, 399
 musculocutaneous nerve repair, 373
 nerve grafts, in peripheral nerve injuries, 218-219, 236
 nerve suture, in World War I, 208, 210
 orthopedic surgery, in irreparable peripheral nerve injuries, 584-585
 paraplegic program, 186-188
 primary nerve suture, 232-233
 protein replacement, in paraplegia, 151
- Results, of—Continued
 radial nerve repair, 406
 radial nerve transplantation, 404
 reconditioning program, in paraplegia, 164
 rhizotomy, in mass reflexes, 182
 spinal cord injuries, in World War I, 3-4
 surgery, in acute spinal cord injuries, 26-27
 in combined bone-peripheral nerve injuries, 424
 in herniated nucleus pulposus, 193-194, 200-201, 202, 203
 in peripheral nerve injuries, 301
 sympathectomy in causalgia, 489-490
 ulnar nerve repair, 396, 400, 401
 urologic management, in paraplegia, 114-117
- Resuscitation, in acute spinal cord injuries, 35, 36, 39
- Retroclavicular injuries, of brachial plexus, 392
- Retrograde pyelography, 106
- Retrograde urography, 111
- Retroparotid space, 441
- Retroperitoneal approach, in—
 femoral nerve injuries, 346, 347
 sympathectomy, 489
- Rhizotomy, 9, 181
- Rhomboids, 310
- RIBA, Lt. Col. L. W., 104
- Riboflavin, in paraplegia, 150
- RICHES, E. W., 71, 89, 93, 94, 95, 114, 115
- Richocheting wounds of spine, 33
- RICHTER, C. P., 213
- RIDDOCH, G., 67, 70, 111
- Ringer's solution for rehydration of frozen dried homografts, 496
- RITCHIE, A. E., 561
- RIZZOLI, Maj. H. R., 513
- ROBERTSON, E. G., 82, 83
- Robinson catheter, 91
- ROBINSON, Lt. Col. J. N., 121
- Roentgenologic examination—
 after frozen dried homografting, 498
 after peripheral nerve surgery, 376, 389, 519
 after sciatic nerve surgery, 409
 in acute spinal cord injuries, 20, 37, 39-40, 45, 46, 47
 in causalgia, after peripheral nerve injuries, 485
 in combined bone-peripheral nerve injuries, 421
 in cord bladder, 121, 124

- Roentgenologic examination—Continued
 in peripheral nerve injuries, 224, 242, 243, 254, 376
 in renal calculi, 103, 106, 152
 in ureteral calculi, 103
 in urinary tract infection, 125
 in vesical calculi, 112
- Roger Anderson splints, 564
- Root pain, in—
 acute spinal cord injuries, 26, 47, 49
 paraplegia, 181
 wounds of cauda equina, 43-44
- Roots of brachial plexus, 305-306, 311
- Ross, J. P., 469
- Rotation of skin flaps, in—
 combined peripheral nerve-skin-soft tissue injuries, 429
 decubitus ulcers, 9-10, 142-143
- Rupture, of—
 aneurysms, 464
 annulus fibrosus, 193
 cord bladder, 89
- Ruptured intervertebral disk. *See* Herniated nucleus pulposus.
- Rusk, H. A., 161
- Sacral nerve roots, formation of sciatic nerve from, 350
- Sacral spinal cord, wounds of, 20, 21, 67
- Sacrifice of peripheral nerve branches, at operation, 396, 400, 405
- Sacrosciatic foramen, 354
- Sacrum, decubitus ulcers over, 11, 61, 87, 131, 137-138, 139, 142, 143
- Saphenous nerve, 345, 346, 413
 cable grafts from, 494
- Sarcolemma, 559
- Sartorius, 344, 350, 407
- Scaleni muscles, 310
- Scalenus anticus, 305, 392
- Scalenus medius, 308, 310, 311, 392
- Scapula, decubitus ulcers over, 131
- Scapular vein, 308
- Scar tissue, pain caused by involvement of nerves in, 579
- SCARFF, Lt. Col. J. E., 33, 120
- Scarpa's triangle, 344, 346, 349
- Scarring:
 about elbow, in radial nerve injuries, 573
 after combined bone-peripheral nerve surgery, 421, 422, 423
 in brachial plexus injuries, 312, 392
 in combined peripheral nerve-skin-soft tissue injuries, 430
- Scarring—Continued
 in combined radial nerve-humerus injuries, 403
 in combined vascular-peripheral nerve injuries, 454, 465
 in common peroneal nerve injuries, 413
 in femoral nerve injuries, 347
 in median nerve injuries, 398
 in peripheral nerve injuries, 236, 301, 304, 305, 322, 364, 369-372, 373-374, 375, 380, 382, 497, 505, 521, 526, 528, 543, 550
 in posterior tibial nerve injuries, 359
 in radial nerve injuries, 326
 in sciatic nerve injuries, 408-409
 in ulnar nerve injuries, 339, 342
- SCHLESINGER, Capt. E. B., 188
- School for training of personnel, in paraplegic program, 7
- SCHULTZ, Maj. E. C., 482
- Schwann cells, 543
- SCHWARTZ, Lt. Col. H. C., 231
- Sciatic nerve:
 anatomy of, 350-353, 407, 409-410
 block of, 369
 branches of, in thigh, 351
 causalgia in, 475, 579
 course of, 350-351
 exposure of, 354-362
 formation of, 350
 frozen dried homografts from, 497, 503, 505, 509, 554
 high lesions of, 380
 injuries of, 249, 350-362, 367, 407-410
 association of, with bone injuries, 416
 association of, with vascular injuries, 455
 equinus deformities after, 580
 in World War I, 210, 354
 plaster fixation after surgery for, 366-367
 positioning at operation for, 354, 362
 prognosis in, 362
 repair of, 354-356, 369
 study of specimens from, 514
 surgical approaches to, 354-362
 transplantation of, 362
- Sciatic neurolysis, 356
- Sciatic notch, 354
- Sciatic palsy, 409
- Sciatic paralysis, trophic changes after, 570
- Scissors gait deformity, 173
- Sclerosis, in peripheral nerve injuries, 528
- SCOVILLE, Maj. W. B., 142

- Scrotal sepsis, in paraplegia, 90, 93, 97, 99, 112, 113
- Secondary closure, of—
decubitus ulcers, 9, 137
suprapubic sinus, 95
- Secondary neuroorrhaphy, 537-538
- Secondary sympathectomy, in causalgia, 490
- Secondary wound closure, in infected bone-peripheral nerve injuries, 421
- Section on Brain Surgery, SGO, 209
- Section of cerebral sensory cortex, 183
- Sedation—
after laminectomy, 57-58
in acute spinal cord injuries, 36
- SEDDON, H. J., 493, 494
- Segmental distribution of paraplegic pain, 178
- Segmental reflex activity, suppression of, in acute spinal cord injuries, 68
- Segregation of patients, with combined bone-peripheral nerve injuries, 415-416
- Selection of personnel, for paraplegic program, 6-8
- SELETZ, E., 391
- Semimembranosus, 351, 356
- Semitendinosus, 351, 356
- Senior Consultant in Neurosurgery, Office of Theater Chief Surgeon, ETOUSA, 26, 120, 230, 241, 243
See also Davis, Col. L.; Spurling, Col. R. G.
- Sensation:
localization of return of, in peripheral nerve injuries, 277
loss of, in acute spinal cord injuries, 36-37, 169
- Sensory branches of femoral nerve, 349
- Sensory examination, in peripheral nerve injuries, 254, 266-272
- Sensory fibers, cross stimulation of, as cause of causalgia, 475
- Sensory function, qualitative determination of return of, in peripheral nerve injuries, 272-273
- Sensory loss, in—
causalgia, after peripheral nerve injuries, 482
peripheral nerve injuries, 212, 224, 253, 569-570
- Sensory paralysis, in—
causalgia, 449
combined peripheral nerve-vascular injuries, 440
- Sensory patterns, in peripheral nerve injuries, 212, 213-217
- Sensory status, assessment of, in peripheral nerve injuries, 251-252
- Sensory testing, in peripheral nerve surgery, 242, 272, 368, 369, 375
- Sepsis, as cause of death, in spinal cord injuries, 116
- Septicemia, in paraplegia, 12
- Sequestration, after bone grafting, 427
- Sequestrectomy, 421
- Serratus anterior, 310
- Serum protein levels—
after laminectomy, 57
in acute spinal cord injuries, 63
in paraplegia, 129, 149
- Serum rehydration of frozen dried homografts, 496
- Seventh U.S. Army, 120
- Sex function, in paraplegia, 101, 101n
- SHERRINGTON, C. S., 268
- Shock—
during laminectomy, 52
in acute spinal cord injuries, 35, 36, 39, 64, 123
in combined peripheral nerve-vascular injuries, 439, 442
- Short saphenous (sural) nerve, 352
- Shortages, of—
equipment, for paraplegic program, 8
laboratory personnel, for peripheral nerve studies, 220
neurosurgical personnel, 241-242
personnel in paraplegic program, 7
- Shortening, of—
bone, in combined bone-peripheral nerve injuries, 246, 249, 305, 380, 496
clavicle, in brachial plexus injuries, 305
humerus, in combined bone-peripheral nerve injuries, 416-420, 422-423
normal bone, in peripheral nerve injuries, 380
- Shoulder joint, arthrodesis of, 318, 571, 572
- Shoulder spica, for transportation splinting, 420
- Shoulder, wounds of, 36
- SHUMACKER, H. B., Jr., 489
- Shumacker technique of sympathectomy, 489
- Shunting of sympathetic-sensory nerve impulses, as cause of causalgia, 476, 478
- Signs, in—
acute spinal cord injuries, 37-38
causalgia, 479, 480-482

- Silk sutures, in peripheral nerve surgery, 243, 388-389, 533, 535
- SILVERMAN, J. J., 279
- SIMEONE, F. A., 74
- SIMONS, I., 80
- SINGER, M., 390
- Sino-Japanese War, peripheral nerve injuries in, 302
- Sixth Service Command, 18
- Skeletal traction, in combined bone-peripheral nerve injuries, 245, 421, 564
- Skin care—
after laminectomy, 59
in combined bone-peripheral nerve injuries, 421
in paraplegia, 134, 135, 151
- Skin changes, in—
causalgia, 481
peripheral nerve injuries, 272
- Skin complications, in acute spinal cord injuries, 35, 38
- Skin grafting, in—
combined bone-peripheral nerve injuries, 421
decubitus ulcers, 30, 135, 139, 143-145, 149, 151
- Skin-peripheral nerve injuries, 429-438
- Skin preparation, in peripheral nerve surgery, 367
- Skin resistance determinations, by dermatometry, 562
- Skin resistance patterns, in peripheral nerve injuries, 213-217, 224
- Skin temperature, in causalgia, 474-475, 481
- Skin temperature tests, in peripheral nerve injuries, 280-282
- Skin, trophic disturbances of, 265-266
- Skiodan, in cystography, 81
- SKOGLUNG, C. R., 476
- Sliding-flap closure of donor sites, for pedicle grafts, 432
- Sliding operations, in decubitus ulcers, 10
- Sling-suture techniques, in peripheral nerve surgery, 384-385, 410
- Small sciatic nerve, 354-356
- Smith-Petersen Vitallium cuff, 426
- SMITHWICK, R. H., 469, 488
- Smithwick technique of sympathectomy, 488-489
- SYNDER, Col. H. E., 19
- Social factors, in paraplegia, 128-129
- Social service personnel, in paraplegic program, 7
- Society of Neurological Surgeons, 195
- Sodium iodide, in cystography, 81
- Soft palate, paralysis of, 441
- Soft tissue-bone-peripheral nerve injuries, 569-570
- Soft tissue-peripheral nerve injuries, 50, 241, 429-438
in World War I, 208
- Soft tissues, calcification of, in paraplegia, 147
- Soleus, 352, 358, 359, 412, 413, 414
- Solution G, 94, 110
- Solution M, 94, 112, 121
- Solutions, for irrigations of cord bladder, 94, 121
- Somatic approach, in paraplegia, 6
- SOULE, Capt. A. B., 147
- Southwest Pacific Area, 121
- Spastic reflexes, in paraplegia, 9, 10, 18, 178-184
- Special discrimination test. *See* Compass test.
- Specifications for facilities, in paraplegic program, 13-14, 17
- Spermatic cord, torsion of, 152
- Sphincterometry, 80, 129
- Spinal accessory nerve, 310, 441, 448
innervation of facial nerve by, 494
- Spinal anesthesia, in peripheral nerve surgery, 249, 369, 408
- Spinal cord:
anatomic transection of, 33, 36
bladder function in complete transection of, 87
bladder neck in complete transection of, 84-85
case fatality rates in transection of, 115
classification of injuries of, 32-35
compression of, 33, 34, 35, 38, 44-47, 182
concussion of, 3, 35, 39, 47
in World War I, 3
contusion of, 39, 55
cord bladder, in—
complete transection of, 69, 71, 86, 94, 116, 117, 122, 123-124
incomplete transection of, 71, 86, 94, 114, 116, 117, 122
decompression of, 44-47
edema of, 33, 34, 37, 38, 55, 68
effect of level of injury of, on work capacity, 187n
hemorrhage into (about), 34
injuries of, 3-191
antimicrobial therapy in, 35

- Spinal cord—Continued
 injuries of—continued
 association of, with other wounds, in
 World War I, 3, 4
 foreign bodies in, 19–20
 gastrointestinal complications in, 35
 in civilian life, 115–116
 in ETOUSA, 25–30
 in MTOUSA, 19–23
 in World War I, 3–4, 18, 31, 47, 67, 119
 incidence of, 19–20
 management of, 31–65
 pain in, 35
 pathologic process in, 32–34
 prevention of infection in, 35
 priapism after, 38, 91, 101, 113, 173
 priority of evacuation in, 26, 240
 prognosis in, 21, 25, 31
 shock in, 35, 36, 39, 64, 123
 statistics of, 25, 120
 statistics of, in World War I, 31
 urologic aspects of, 67–125
 suture of, in World War I, 3
See also Acute spinal cord injuries, Paraplegia, Spine, spinal injuries in special locations, etc.
- Spinal fluid rehydration of frozen dried homografts, 496
- Spinal shock, 53, 68, 69, 71, 74, 76, 81,
- Spine:
 case fatality rate for injuries of, 31–3294
 in Civil War, 115
 in World War I, 31, 114, 115
 closed injuries of, 23, 35, 38
 depressed fractures of, 40
 etiology of injuries of, 25, 32–33
 first aid in wounds of, 35–36
 fractures (fracture-dislocations) of, 20, 25
 penetrating wounds of, 33, 38–39
 perforating wounds of, 33
 ricocheting wounds of, 33
 roentgenologic examination in wounds of, 20
 through-and-thorough wounds of, 46–47
See also Acute spinal cord injuries, Paraplegia, Spinal cord injuries, spinal injuries in special locations, etc.
- Spinothalamic cordotomy, 9
- Splinting:
 after debridement, in peripheral nerve injuries, 235
 after peripheral nerve surgery, 236–237
 effect of, in causalgia, 481
- Splinting—Continued
 in peripheral nerve injuries, 242, 246, 420–421, 563, 565–566
See also Transportation splinting.
- Split thickness skin grafts, in—
 combined peripheral nerve-skin-soft tissue injuries, 429, 430–432
 decubitus ulcers, 143
- Spontaneous improvement, in causalgia, 470, 473, 473n, 477, 488
- Spontaneous regeneration, in peripheral nerve injuries, 211, 224, 239, 253, 301, 373–374, 448
- Spring scale, in peripheral nerve testing, 256–263
- SPRINZ, Maj. H., 149
- Spurious aneurysm, of vertebral artery, 442
- SPURLING, Col. R. G., 195, 219, 225, 230, 243, 469, 494
- Stabilization of foot, in irreparable peripheral nerve injuries, 580
- Staged frozen dried homografting, 498
- Staged surgery, in combined vascular-peripheral nerve injuries, 465
- Stainless steel sutures, in peripheral nerve surgery, 242, 388
- Stamp grafts, in decubitus ulcers, 10
- Stanford University, 188
- Staphylococcal infections, in paraplegia, 72, 103
- Staphylococcus aureus* renal infections in paraplegia, 103
- Stasis, as cause of renal calculi, 104, 105
- Statistics:
 acute spinal cord injuries, 19–20, 25, 26, 31–32, 64–65, 120 in World War I, 31, 119
 ambulation in paraplegia, 165
 causalgia after peripheral nerve injuries, 470, 473, 473n, 480, 490
 combined bone-peripheral nerve injuries, 246, 422–428
 cord bladder, 30, 88–89, 114–117, 121, 122–123 in World War I, 114
 decubitus ulcers, 22, 137, 142
 disruption of suture line after peripheral nerve repair, 244
 exploratory laminectomy, 182
 frozen dried homografts, 495, 502–512
 herniated nucleus pulposus, 198–201, 203
 intermittent catheter drainage of cord bladder, 90
 paraplegia, 30, 122–123, 127–129, 187, 187n in VA hospitals, 12–13n

- Statistics—Continued
 paraplegics in ZI hospitals, 14-17
 peripheral nerve grafts, 218-219, 219n
 peripheral nerve injuries, in—
 ETOUSA, 237-238
 MTOUSA, 237-238
 World War I, 209-210
 Peripheral Nerve Registry, 228-230
 peripheral nerve surgery at Halloran General Hospital, 513
 priapism, 113, 173
 primary nerve suture, 232-233, 303
 renal calculi in paraplegia, 104-105
 renal infection in paraplegia in World War I, 102
 sex function after acute spinal cord injuries, 101
 timelag in early nerve suture, 247-249
 transfer of paraplegics to VA hospitals, 18
 vesical calculi, 112
 Steel wire sutures, in decubitus ulcers, 142
 Steindler transplantation operation, for peripheral nerve injuries about elbow, 572-573
 Step-through gait, 170
 Stereoscopic roentgenograms, in spinal cord injuries, 39, 182
 Sternocleidomastoid, 308, 311, 312
 STEWART, O. W., 93
 Stone-dissolving solutions, in renal calculi, 152
 STOOKEY, B., 207, 301, 303, 408
 STORCK, Lt. Col. A. H., 7
 STRAIN, W. L., 193
 Streptomycin, in urinary tract infections, in paraplegia, 103, 104, 125
 Stretch fibrosis, in peripheral nerve injuries, 541-543, 558
 Stretch ischemia, in peripheral nerve injuries, 513
 Stretch palsies, in peripheral nerve injuries, 364, 381, 404, 526, 547
 Stretch paralysis, in peripheral nerve injuries, 566
 Stripping of nerve branches, in peripheral nerve surgery, 305, 326, 350, 403-404
 Stryker frame, 9, 10, 95, 108, 134, 135, 155, 162, 163, 184, 185, 189
 Subarachnoid alcoholic injection, 181
 Subarachnoid block, 26, 38
 Subarachnoid hemorrhage, in acute spinal cord injuries, 34, 55
 Subastragalar arthrodesis, 582, 584
 Subastragalar joint, Lambrinudi operation on, 580
 Subclavian aneurysm, association of brachial plexus injuries with injuries of, 448
 Subclavian artery, 308, 312, 392
 injury of, associated with median nerve injury, 543
 Subclavius, 308, 310
 Subdural hematoma, in acute spinal cord injuries, 54
 Subdural hemorrhage, in acute spinal cord injuries, 34
 Sublimis tendons, use of, in median nerve paralysis, 576-577
 Subscapular nerve, 310
 Subscapularis, 310, 317, 318
 Substitution movements, in peripheral nerve injuries. *See* Trick movements.
 SURY, H. I., 94, 110, 121
 Sucking wounds of chest, 51
 Sudeck's atrophy, 477-478, 486
 Sulfadiazine—
 after laminectomy, 58
 in acute spinal cord injuries, 56
 in combined bone-peripheral nerve injuries, 245
 in primary nerve suture, 232
 in urinary tract complications of spinal cord injuries, 22, 103-104
 Sulfanilamide solutions, for bladder irrigations, 94
 Sulfathiazole, in renal infections, 103-104
 Sulfonamide therapy—
 at laminectomy, 56
 in epididymitis, 113
 in periurethral abscess, 113
 in renal infections, 103-104
 in urinary tract infections, 124, 125
 Summation phenomena in peripheral nerve testing, 273
 Superficial epigastric artery, 349
 Superficial pressure (touch) sensation in peripheral nerve testing, 275-276
 Superficial volar arch, 333
 Supinator, 320, 325, 326
 Supplementary motor movements in peripheral nerve injuries, 212
 Supplies. *See* equipment.
 Suppression, of—
 reflexes in acute spinal cord injuries, 74
 supplementary movements in testing muscle strength, 263-264
 Supraclavicular approach, to brachial plexus injuries, 392

- Supraclavicular branches, of—
 brachial plexus, 308
 cervical plexus, 312
- Supracondylar fracture of humerus, associated with radial nerve injury, 428
- Suprapubic cystostomy, in cord bladder, 22, 30, 62-63, 89, 95-97, 99-100, 112, 117, 118, 120, 121, 122, 123-124, 176
 in World War I, 119
- Suprapubic drainage, of periurethral abscess, 113
- Suprascapular nerve, 310, 514
- Supraspinatus, 310
- Sural nerve autograft, in cutaneous nerve injury, 546-547
- Sural nerve injuries, 514
- Sural vein, 353
- Surface anatomy, of—
 axillary nerve, 317
 brachial plexus, 311
 femoral nerve, 346
 median nerve, 328-330
 musculocutaneous nerve, 314
 radial nerve, 321
 ulnar nerve, 337
- Surgeon General, The, 5, 13, 17, 18, 225
See also Office of the Surgeon General.
- Surgeon General's Office, in World War I, 209
- Surgical approach, to—
 axillary nerve injuries, 317-318
 brachial plexus injuries, 311-313
 femoral nerve injuries, 346-349
 median nerve injuries, 330-333
 musculocutaneous nerve injuries, 314-316
 radial nerve injuries, 322-326
 sciatic nerve injuries, 354-362
 ulnar nerve injuries, 338-342
- Surgical Consultants Division, OTSG, 14, 151n, 226, 277
- Surgical neck of humerus, 317, 318
- Survey of paraplegics, in ZI hospitals, 14-17, 127-129, 160, 186
- Surveys of paraplegic centers, 6-7, 8-11
- Survival in paraplegia, age factor in, 12-13n
- Suture à distance, 381
- Suture line, disruption of, after peripheral nerve surgery, 244, 519, 533, 539-541
- Suture material, in peripheral nerve surgery, 229, 243, 365, 388-389, 533-535
- Suture, of—
 neuroma, 380
 spinal cord, in World War I, 3
- Suture sites, classification of, in peripheral nerve surgery, 531-533
- Sutureless technique of peripheral nerve surgery, 389-390
- Sweat tests, in—
 causalgia, 490
 peripheral nerve injuries, 279-280
- Swimming pools, in—
 paraplegia, 9, 161, 162
 peripheral nerve injuries, 567
- Swing-through gait, 170
- Sympathectomy:
 in causalgia, 414, 470, 473n, 475-477, 486-487, 488-489, 490
 in combined peripheral nerve-vascular injuries, 464
 in management of pain in paraplegia, 180, 181
 in median nerve injuries in hand, 399
 in phantom limb, 478
 technique of, 488-489
- Sympathetic innervation, of upper extremity, 310
- Sympathetic nerve block, in—
 causalgia, 473n, 476-477, 486-488, 489-490
 paradoxical vasoconstriction, 280
 phantom limb, 478
- Sympathetic nerve supply, loss of, in peripheral nerve injuries, 559
- Sympathetic nervous system, in—
 causalgia, 219
 spinal cord injuries, 178
- Symptoms, in—
 acute spinal cord injuries, 36-37
 causalgia, 479-485
 combined peripheral nerve-vascular injuries, 440-441, 448
 peripheral nerve injuries, 280
 urinary tract complications in paraplegia, 102, 103, 112, 146, 152
- Syndrome, of posterior retrocarotid space, 442
- Synostosis of radius and ulna, resection of, 424
- Syringe irrigations, in catheter management of cord bladder, 91
- Tabes, bladder function in, 80
- Tables of organization, of general hospitals, 220
- Tactile stimulation, in median nerve injuries, 397
- Tannic acid, in—
 decubitus ulcers, 137
 sweat tests in peripheral nerve injuries, 279

- Tantalum band technique of frozen dried homografting, 498
- Tantalum cuffs, 208, 226, 236, 243-244, 375, 387-388, 422, 430, 521, 535, 537, 547, 550
- Tantalum sleeve technique of frozen dried homografting, 498, 503-506, 508
- Tantalum sutures, in—
decubitus ulcers, 142
peripheral nerve surgery, 208, 226, 242, 243, 253, 339, 342, 364, 376, 384, 388-389, 395, 410, 422, 519, 533-535, 538
- Tantalum tubes, in peripheral nerve repair, 389
- TARLOV, I. M., 383, 390, 498
- TAYLOR, A. C., 496
- Technical errors in sympathectomy, in causalgia, 490
- Technique, of—
ambulation, in paraplegia, 170-173
bladder irrigations, 91-94
catheter drainage, in cord bladder, 91
combined bone-peripheral nerve surgery, 421-422
compass test, in peripheral nerve injuries, 278
cystometry, in cord bladder, 73
estimation of pain and touch points, in peripheral nerve injuries, 276
evacuation, in paraplegia, 64, 132-135
examination, in peripheral nerve injuries, 251-300
exposure of peripheral nerves, 311-313, 316, 317-318, 322-326, 330-333, 338-342, 346-349, 354-362
femoral nerve repair, 407
footprint and handprint testing, in peripheral nerve injuries, 265
frozen dried homografting, 497-498
gaining length in peripheral nerve surgery, 236, 305, 313, 316, 318, 326, 335, 350, 356, 359, 362, 381-382, 537
galvanic stimulation, in peripheral nerve injuries, 565
hemilaminectomy, 56-57
history-taking, in peripheral nerve injuries, 253-254
laminectomy, 52-57
localization of returning sensation, in peripheral nerve injuries, 277
management of cord bladder, 22, 30, 61-63, 86-100, 119-125
median nerve repair, 396-399
nerve block in muscle testing, in peripheral nerve injuries, 264
498991v-59-48
- Technique, of—Continued
neurolysis, 374-375
nerve transplantation, 342-343, 379-380, 400, 423
orthopedic surgery, in irreparable peripheral nerve injuries, 569-585
peripheral nerve repair, 236, 242-244, 247-249, 363-482
peroneal nerve repair, 411-412
physical therapy, in peripheral nerve injuries, 245, 246-247, 562-568
plasma clot anastomosis, in peripheral nerve surgery, 389-390
posterior tibial nerve repair, 412-414
preparation of—
frozen dried homografts, 495
peripheral nerve specimens, for histopathologic study, 513-514
procurement of nerve grafts, from cadavers, 495-496
qualitative (quantitative) peripheral nerve testing, 261, 273, 274, 275
radial nerve repair, 62-64
sciatic nerve repair, 409-410
skin temperature testing, in peripheral nerve injuries, 266-272, 282
suprapubic cystostomy, 62, 97
surgery, in decubitus ulcers, 141-145
sympathectomy, 488-489
sweat tests, in peripheral nerve injuries, 279, 280
tantalum sleeve method of frozen dried homografting, 503
tibialis posticus transplantation, 582-584
transplantation of flexor carpi radialis, 574
ulnar nerve repair, 400-401
use of inductorium, 372-374
- Temporary suture, in peripheral nerve injuries, 533, 538-539
- Tendo achillis, 359, 413
- Tendon contraction, in paralysis below knee, 579
- Tendon injuries, associated with peripheral nerve injuries, 253, 304, 398
- Tendon repair, with ulnar nerve repair, 342
- Tendon splitting, in hand injuries, 406
- Tendon transplantation, in peripheral nerve injuries, 380, 411, 427, 555, 568, 573-574, 579, 580
- Tenodeses, in irreparable nerve injuries of lower extremity, 580
- Tenotomy, in paraplegia, 173
- Tension pneumothorax, 21
- Teres major, 310

- Teres minor, 317, 318
- Terminal branches, of—
 brachial plexus, 308
 common peroneal nerve, 353, 361
 femoral artery, 350
 femoral nerve, 344-346, 349
 posterior tibial nerve, 352
 sciatic nerve, 357-362
- Test:
 for measurement of muscle strength, in hands and feet, 256-263
 of motor function, at initial wound surgery, 242
 of sensory function, at initial wound surgery, 242
See also specific tests.
- Theater Chief Surgeon, ETOUSA, 29, 246
- Thenar crease, 328, 333
- Thenar eminence, 314, 328, 333, 399
- Thenar muscle, innervation of, 263
- Therapeutic test, in causalgia, 486-488
- Thermocouple, 281
- Thiamine, in paraplegia, 150
- Thiersch grafts, in decubitus ulcers, 10
- Thigh, exposure of sciatic nerve in, 356-357
- Thigh pain, in causalgia, 478
- Thimerosal, tincture of. *See* Merthiolate.
- Thiopental sodium. *See* Pentothal sodium.
- Third Service Command, 18
- Thoracic laminectomy, 51
- Thoracic nerves, formation of brachial plexus from, 305-308, 312, 328, 335
- Thoracic spinal cord:
 priapism, after transection of, 173
 wounds of, 20, 29, 30, 35, 36, 39, 47, 59, 63, 64, 80-81, 115, 118, 171
- Thoracoabdominal wounds, 19
- Thoracodorsal nerve, 322
- THOM, D. A., 161
- THOMAS, W. H., 94
- THOMSON-WALKER, J., 69, 90, 95, 102, 114
- Thompson-Boyle operation in median nerve paralysis, 577
- THOMPSON, G. J., 81, 94, 98, 117
- Thrombin, for hemostasis, at peripheral nerve surgery, 365, 385, 386
- Thrombosis, in peripheral nerve injuries, 528, 536
- Through-and-through wounds of spinal canal, 46-47
- Thumb-finger opposition, operations for, 577
- Tibia:
 decubitus ulcers over, 131
- Tibia—Continued
 fractures of, associated with peripheral nerve injuries, 421
- Tibial component of sciatic nerve, 410
- Tibial nerve, 356
 anatomy of, 351-353
 autogenous grafting of, 394
 branches of, 351-352
 exposure of, in popliteal space, 357-359
 formation of, 351, 357
 injuries:
 combined with vascular injuries, 455
 repair of, 412-414, 496-497
- Tibial recurrent nerve, 353
- Tibialis anticus, 353, 361
- Tibialis posticus, 352, 412
 transplantation of, in irreparable peroneal nerve injuries, 582-584
- Tidal drainage of bladder, 22, 30, 62, 63, 72-73, 92-94, 99, 115-116, 117, 119-121, 123, 124, 125, 152, 176
- Timelag, in peripheral nerve injuries, 230, 514-515, 531-533, 535-537, 547
 in World War I, 210
- Timing, of—
 Assessments of nerve regeneration, 226
 changes of position, in paraplegia, 131, 135
 combined bone-peripheral nerve surgery, 236, 245, 402-403, 415-416, 420, 424-425
 combined peripheral nerve-plastic surgery, 429, 431
 combined vascular-peripheral nerve surgery, 464
 evacuation—
 in acute spinal cord injuries, 63-64
 in paraplegia, 30
 joint extension after peripheral nerve repair, 244
 laminectomy, in acute spinal cord injuries, 21, 41, 44-47, 48, 49, 182
 operation—
 in infected bone-peripheral nerve injuries, 421
 in irreparable nerve injuries of lower extremity, 570
 in renal calculi, 109
 peripheral nerve surgery, 211, 231, 233, 234, 235, 239-242, 247, 249, 363-364, 375, 515, 519, 531-533, 560
 in World War I, 208, 210
 reexploration after frozen dried homografting, 499
 sympathectomy, in causalgia, 488

- TINEL, J., 207, 272, 303, 474, 477
 Tinel's sign, in peripheral nerve injuries, 212-213, 224, 272-273, 428, 519, 531, 547, 555
 TINSLEY, M., 31, 32, 46, 65
 Toe drop brace, after tibialis anticus transplantation, 584
 Toes:
 clawing of, 265, 579
 decubitus ulcers on, 131
 frozen joints in, 246
 pain in, in causalgia, 478-480
 Touch and pain points, estimation of, in peripheral nerve injuries, 276
 Touch sensation, in peripheral nerve injuries, 269, 273, 275-276
 Touch stimulation, in median nerve injuries, 397
 Tourniquet, in peripheral nerve repair, 243
 Trabeculations, of bladder wall, 79-80, 81-82
 Traction:
 effect of, in peripheral nerve injuries, 219
 in combined bone-peripheral nerve injuries, 420-421, 425, 426
 Traction injuries of brachial plexus, 391
 Traction management of spastic reflexes, 180
 Traction on neuroma, 380
 Traction palsies, in peripheral nerve injuries, 208, 364, 381, 403
 Traction paralysis, after peroneal nerve repair, 411
 Traction suspension, 420
 Training of neurosurgical personnel, 241-242
 for paraplegic program, 6-8
 in electrodiagnostic techniques, 217
Traité des Sections Nerveuses, 303
 Transfusion. *See* Blood replacement, Replacement.
 Transit hospitals, 240
 Transperitoneal approach—
 in sympathectomy, 489
 to femoral nerve injuries, 347
 Transplantation, of—
 anastomosis, in peripheral nerve surgery, 386
 common peroneal nerve, 411
 flexor tendons, 406
 median nerve, 335, 395, 396
 peripheral nerves, 207, 219, 236, 243, 305, 379-380, 550, 551
 in World War I, 210
 radial nerve, 326, 403-404, 423, 428
 sciatic nerve, 362
 Transplantation, of—Continued
 ulnar nerve, 339, 340, 342-343, 378, 395-396, 400, 401, 576
 wrist and digital flexors, 572-573
 Transplantation operations, in irreparable nerve injuries, 571-572, 573-575, 582-584
 Transplanted muscles, reeducation of, 577
 Transportability, in acute spinal cord injuries, 48-49
 Transportation, in—
 acute spinal cord injuries, 35
 paraplegia, 27, 29, 130, 131-135
 Transportation splinting, in—
 combined bone-peripheral nerve injuries, 246, 420-421
 peripheral nerve injuries, 137, 242, 246, 420-421
 Transurethral resection of bladder neck, 98
 Transversalis muscles, 346, 349
 Transverse carpal ligaments, 328, 331, 333, 335
 Transverse cervical vessels, 308
 Transverse myelitis. *See* Acute spinal cord injuries, Paraplegia.
 Trapezius, 308
 Mayer transplantation operation on, 572
 Traumatic amputations, in paraplegia, 146
 Traumatic arthritis, 486
 Traumatic division of peripheral nerves, at operation, 208
 Triage, in peripheral nerve injuries, 240, 246
 Triceps, 317, 318, 320, 322, 323, 325, 326, 330, 335, 393, 403
 transplantation of long head of, to acromion, 571-572
 Trick movements, in peripheral nerve injuries, 252, 261, 263-264, 560, 568
 Trigger point in tests of sensory function, 272
 Trigone in cord bladder, 80
 Triplegia, 183
 Trochanters, decubitus ulcers over, 87, 131, 137, 139, 142
 Trophic changes, in—
 causalgia, 481
 peripheral nerve injuries, 340, 569, 570
 tests of, 265-266
 spinal cord injuries, 169
 Trophic ulcers, 412
 Trunk, causalgia in, 478
 Trunks of brachial plexus, 306, 311
 branches from, 310
 TUBBY, A. H., 575
 Tube feeding, in acute spinal cord injuries, 63
 Tuberosity of ischium, 351

- Tubulization technique, in—
 combined peripheral nerve-skin-soft tissue injuries, 429
 peripheral nerve injuries, 381, 389
- Tunisian campaign, 20, 202, 231
- TURCO, Maj. V., 575, 582
- Two-point test. *See* Compass test.
- Two-stage repair, of peripheral nerve injuries, 380-381
- Tyrodé's grafts, 144
- UHLE, A. A., 80
- Ulna, fractures of, associated with peripheral nerve injuries, 238, 420
- Ulnar artery, 331, 333, 335
- Ulnar collateral artery, 330
- Ulnar groove, 335, 337, 340
- Ulnar nerve, 323, 333
 anatomy of, 335-337
 assumption of functions of, by median and radial nerves, 352
 autogenous grafting of, 494
 branches of, 335-337
 course of, 335-337
 differentiation of, from median nerve, 330, 333
 exposure of, 338, 342, 395
 formation of, 308, 335-337
 injuries of, 335-343
 clawhand deformity after, 571
 combined with bone injuries, 238, 416
 flexion-relaxation at operation for, 378
 incidence of, 514
 positioning at operation for, 338, 339, 340
 repair of, 303, 395-397, 400-401, 496-497
 study of, by handprints, 265
 study of specimens from, 514
 surgical approach to, 338-342
- innervation by, of thenar and flexor profundus muscles, 263
- involvement of, in median nerve injuries, 394, 395, 396-397
- mobilization of, 338, 339
- orthopedic surgery, in irreparable injuries of, 575-576
- overlap into median nerve area, 263-264
- paralysis of, 252
- physiology of, 340
- surface anatomy of, 337
- transplantation of, 339, 340, 342-343, 378, 396-397, 400, 401, 576
- Ulnar vein, 335
- Undermining technique, in closure of decubitus ulcers, 10, 141
- United Kingdom Base, 120
 general hospitals in, 26
 herniated nucleus pulposus in, 201
 neurosurgical centers in, 240, 241, 247
- United States. *See* Zone of Interior.
- Upper extremity:
 bone shortening in, 380
 combined bone-peripheral nerve injuries in, 584
 combined peripheral nerve-vascular injuries in, 439n, 448-454
 incidence of peripheral nerve injuries in, 514
 irreparable peripheral nerve injuries in, 569, 571-578
 physiology of, 304-305
 prognosis of combined peripheral nerve-vascular injuries in, 458
- Urea nitrogen levels, in paraplegia, 129
- Urea ointment, in decubitus ulcers, 137
- Ureteral calculi, 111
- Ureteral colic, 111
- Ureteral complications, of cord bladder, 111
- Ureteral reflux, 82, 100, 102, 112
- Ureterotomy, 111
- Ureters:
 relation of, to femoral nerve, 347
 status of, after acute spinal cord injuries, 100-101
- Urethra, status of, in cord bladder, 79
- Urethral fistula, in cord bladder, 113
- Urethral infection, during drainage of cord bladder, 90-91, 93, 99
- Urethral obstruction, in cord bladder, 80
- Urethritis, 62
- Urethrocytography, 80, 82-86, 98
- Urethrostomy, 90
- Urinalysis, in paraplegia, 72-73, 101, 124, 129
- Urinary calculi, in cord bladder, 152-153, 152n
- Urinary tract infection:
 as cause of death, in spinal cord injuries, 11-12, 90, 114-115
 blood cultures in, 146
 in acute spinal cord injuries, 35
 in nondrainage management of cord bladder, 88, 89
 in paraplegia, 13, 30, 60, 70-71, 86, 87, 95, 146
 in perineal urethrostomy, 97
 roentgenologic examination in, 125

- Urinary tract infection—Continued
See also Urologic, special structures of urinary tract.
- Urologic aspects, of spinal cord injuries, 67-125
- Urologic care, of paraplegics, during evacuation, 29
- Urologic complications, of spinal cord injuries, 18, 22, 32, 101-114
- Urologic management, of spinal cord injuries, 67-125
- Urologists, in paraplegic program, 190
- U.S. Public Health Service, 209
- Vagus nerve, 441
- Vascular centers, in Zone of Interior, 212, 441, 455, 464, 467
- Vascular changes, in peripheral nerve injuries, 558, 559
- Vascular injuries—
 as cause of causalgia, 474-475
 combined with peripheral nerve injuries, 211-212, 222, 237, 238, 243, 253, 280-281, 364, 398, 439-467
 in World War I, 208
 in paraplegics, 146
- Vascular occlusion, combined with peripheral nerve injuries, 458-464, 543
- Vascular-peripheral nerve-bone injuries, combined orthopedic techniques in 569-570
- Vascular supply, protection of, at peripheral nerve surgery, 376
- Vascular theory, of causalgia, 474-475
- Vascularity, after debridement, in peripheral nerve injuries, 235
- Vascularization, after frozen dried homografting, 497, 504, 505, 506, 508, 512
See also Pathologic process, Histopathologic process, etc.
- Vas deferens, retrograde extension of, infection by, 112
- Vasoconstriction, in causalgia, after peripheral nerve injuries, 474-475, 481, 486-487
- Vasodilatation, in causalgia, 474-475, 481-485
- Vasomotor changes, in—
 acute spinal cord injuries, 38
 causalgia, after peripheral nerve injuries, 481, 485
 peripheral nerve injuries, 562
- Vasomotor reactions, in activity of bladder reflex, 76
- Vasomotor symptoms, in peripheral nerve injuries, 280, 562
- Vasopressin. *See* Pitressin.
- Vastus intermedius, 345
- Vastus medialis, 345
- V-E Day, 120, 246
- VELLACOTT, P. N., 88, 102
- Velpeau dressing, after—
 brachial plexus surgery, 378, 393
 radial nerve surgery, 404
- Venae comitantes, 330
- Venous tubes, in peripheral nerve repair, 389
- VERNT, 442
- Vertebrae, fractures of, 33, 35, 47, 132
See also Spine.
- Vertebral artery, spurious aneurysm of, 442
- Vertebral erosion, by aortic aneurysms, 458
- Verumontanum, 83
- Vesical calculi, 14, 97, 99, 111-112, 122
- Vesical neck obstruction, in cord bladder, 80
- Veterans' Administration:
 care of paraplegics in, 186-187
 followup of paraplegics in, 12-13n, 187n, 219n, 230
 transfer of paraplegic program to, 5, 7, 13-18, 123
- Veterans' Administration hospitals:
 postwar expansion of, 224
 studies of—
 cord bladder in, 81n, 99n, 101n
 paraplegia in, 152n
 peripheral nerve regeneration in, 217
 sex function in, 101n, 114n
- Veterans' Bureau, 209
- Vibratory sense, testing of, in peripheral nerve injuries, 266-272
- VILLARET, 442
- Visualization, of peripheral nerve injuries, at debridement, 233-234, 235, 242
- Vitamin supplements, in—
 acute spinal cord injuries, 63
 combined bone-peripheral nerve injuries, 421
 paraplegia, 140, 150, 175
 renal infection, 103
- V-J Day, 14
- Vocal cords, abduction paralysis of, 448
- Vocational instructors, in paraplegic program, 190
- Vocational training, of paraplegics, 7
- Volar branches, of ulnar nerve, 335, 342
- Volar interosseous artery, 320

- Volar interosseous branch, of median nerve, 398
 Volar interosseous nerve, 328, 331
 Volkmann's contracture, in median nerve injuries, 394
 Voluntary neurogenic bladder, 71
 Vomiting, in—
 renal calculi, 106
 renal infection, 102
 von Frey's hairs, 271, 275-276
 VULPIAN, 303
- WAC'S, in paraplegic program, 7-8, 191
 Walkers, in paraplegia, 9, 13, 169, 171
 WALLACE, A. B., 385
 Wallerian nerve degeneration, 303, 515
 WALSH, M. N., 193
 War Department Circular:
 No. 209, 13 July 1945—201
 No. 212, 29 May 1944—200
 No. 224, 21 Sept. 1943—221, 222
 No. 423, 27 Oct. 1944—222, 223
 War Department Technical Bulletin (TB MED) 162, May 1945—5, 181, 183
 Ward attendants, in paraplegic program, 6
 Ward officers, in paraplegic program, 6, 189-190
 Wardmasters, in paraplegic program, 6
 WARE, M. W., 111
 WARREN, S. L., 193
 Water mattresses, in paraplegia, 3, 58
 WATKINS, K. H., 83
 WEARY, Capt. W. B., 19
 WEBB-JOHNSON, A. E., 88, 102
 Weight loss, in paraplegia, 5, 116
 WEISS, P., 389, 495, 496
 WESSON, M. B., 89
 Wheelchair existence, in paraplegia, 5, 116
 Whirlpool bath, in peripheral nerve injuries, 564
 WHITCOMB, Maj. B. B., 513
 WHITE, Capt. J. C., (MC) USN, 264, 469, 470, 475, 477, 485, 489
 Whitman College, 11
 WOODHALL, Lt. Col. B., 225, 243, 272, 382, 476, 495
 Work capacity, after ulnar nerve injury, 575-576
 Work furloughs, in peripheral nerve injuries, 223-224, 566-567, 568
 Work tolerance, in paraplegia, 16
 World War I:
 acute spinal cord injuries in, 3-4, 31, 67, 119
 World War I—Continued
 case fatality rate of—
 renal infection in, 101
 spinal cord injuries in, 114, 115
 causalgia in, 469
 combined peripheral nerve-vascular injuries in, 439, 442, 448, 455
 cord bladder in, 119
 decubitus ulcers in, 130
 experimental studies on peripheral nerve injuries in, 207, 219
 followup on peripheral nerve injuries in, 230
 herniated nucleus pulposus in, 193
 incidence of peripheral nerve injuries in, 237
 laminectomy in, 41
 management of—
 cord bladder in, 88, 89, 90
 peripheral nerve injuries in, 234
 nerve grafting in, 219
 neuropathologic studies on peripheral nerve injuries in, 219
 neurosurgical centers in, 208, 209
 peripheral nerve injuries in, 207-210, 225, 231, 301, 302
 quantitative testing of muscle strength in, 256-259
 records of peripheral nerve injuries in, 254
 sciatic nerve injuries in, 354
 spinal concussion in, 47
 urologic complications of paraplegia, 114
 wounds of—
 abdomen in, 3, 4
 chest 3, 4
 Wound infection. *See* Infection.
 Wounding agents, in—
 combined peripheral nerve-vascular injuries, 147, 439-440
 peripheral nerve injuries, 235, 399, 521
 spinal cord injuries, 25, 32-33, 35, 102, 128
 Wounds. *See* specific types and areas.
 Wrist:
 ankylosis of, after prolonged immobilization, 584
 exposure of—
 median nerve injuries at, 333
 ulnar nerve injuries at, 340-342
 frozen joint in, 246
 fusion operations on, in irreparable peripheral nerve injuries, 571
 median nerve injuries at, 397, 398

- Wrist—Continued
transplantation of origins of humeral flexors on, 572-573
- Wristdrop, in peripheral nerve injuries, 237, 573
- Wrock, Maj. D. H., 237
- YOUNG, H. H., 119
- YOUNG, J. Z., 389
- ZEIFERT, Col. M., 161
- Zinc peroxide, in decubitus ulcers, 10, 138
- Zone of Interior:
definitive nerve surgery in, 246, 247, 363
electrodiagnosis in, 560-561
evacuation of—
casualties with peripheral nerve injuries to, 240-241, 246
paraplegics to, 63-64, 123, 131-134
- Zone of Interior—Continued
evacuation of—continued
patients with herniated nucleus pulposus to, 202-203
evacuation to, after peripheral nerve repair, 244, 247
galvanic-tetanus ratio studies in, 562
management of—
cord bladder in, 121-123
herniated nucleus pulposus in, 194-202
paraplegics in, 5-18, 127-191
neurosurgical centers in, 9, 212, 219, 441, 470, 547, 568
neurosurgical centers, in World War I, 208, 209
policies on peripheral nerve injuries in, 211-230
skin grafting of decubitus ulcers in, 30
survey of paraplegics in, 14-17, 127-129, 160, 186
vascular centers in, 212, 441, 455, 464, 467



History of the Medical Department, U.S. Army, in World War II

DISTRIBUTION LIST

NEUROSURGERY, VOLUME II

OSD (1)	Army Maint Bd (1)	Med Sec, Gen Depot (1)
OSA (1)	USA Arty Bd (1)	AH (6)
ASA (CMA) (1)	USA Armor Bd (1)	USA Hosp 1-100 beds (1)
ASA (FM) (1)	USA Armor Test Bd (1)	USA Hosp
ASA (LOG) (1)	USA Inf Bd (1)	*#100-500 beds (3)
ASA (MP & RF) (1)	USA Air Def Bd (1)	*#500 up (5)
ASA (1)	USA Air Def Test Sec (1)	WRAMC (10)
CofS (1)	USA Abn & Elct Bd (1)	WRAIR (5)
AFSWP (1)	USA Avn Bd (1)	BAMC (20)
DCSPER (1)	USCONARC (2)	Pers Cen (1)
ACSI (1)	USARADCOM (1)	Army Terminals (2)
DCSOPS (1)	USARJ/UNC/EA(R) (1)	ATTTC (1)
DCSLOG (1)	MAJ/OS COMDS (3)	GTTC (1)
ACSRC (1)	SHAPE (3)	PTTC (1)
CAMG (1)	Southern European TF (1)	RC (1)
CUSARROTC (1)	OS Base Comd (1)	PG (1)
CofF (1)	*Log Comd (1)	AFES (1)
CINFO (1)	MDW (3)	Arsenals (1)
CNGB (1)	Armies (2)	Med Fld Maint Shops (1)
CLL (1)	Corps (1)	AFIP (5)
DRD (1)	Corps (Res) (1)	DB (1)
CMH (2)	Bat Gp (1)	Disp
OCSpWar (1)	*#Div (2)	Named or Numbered (1)
TIG (1)	USATC (1)	General (2)
TJAG (1)	Brig (1)	Industrial (1)
TPMG (1)	Regt/Gp (1)	MAAG (5)
TAG (1)	Bn (1)	Mil Mis (3)
CofCH (1)	Med Bn (Sep) (1)	JBUSMC (1)
CofEngrs (1)	Med Co (1)	Units organized under fol-
CmlC (1)	Med Co (Sep) (1)	lowing TOE's:
CofT(1)	Med Det (Sep) (1)	*#8-22 (1)
CSigO (1)	Ft & Camp (2)	8-571 (1)
TQMG (1)	USMA (2)	*#8-581 (1)
CofOrd (1)	CGSC (3)	8-590 (2)
Technical Svc Bd (1)	ARWC (3)	*Med Lab (2)
Chaplain Bd (1)	Svc Colleges (3)	*RA units and USAR.
CAMG Bd (1)	Br Svc Sch (3)	#RA units and NG.
TAG Bd (1)	Joint Sch (3)	
USA Intel Bd (1)	Specialist Sch (2)	